

MARCH 1980 \$1.50

Popular Science®

The **What's New** magazine

ALCOHOL FUELS

—can they replace gasoline?

Traction-drive transmission

It's infinitely variable, and helps recover braking energy, too

COLLIDING-BEAM ACCELERATORS

Will they reveal the ultimate particles?

Get 60 TV channels!
How to tune in SATELLITE TV



MAXIMUM TORQUE, ZERO SPEED

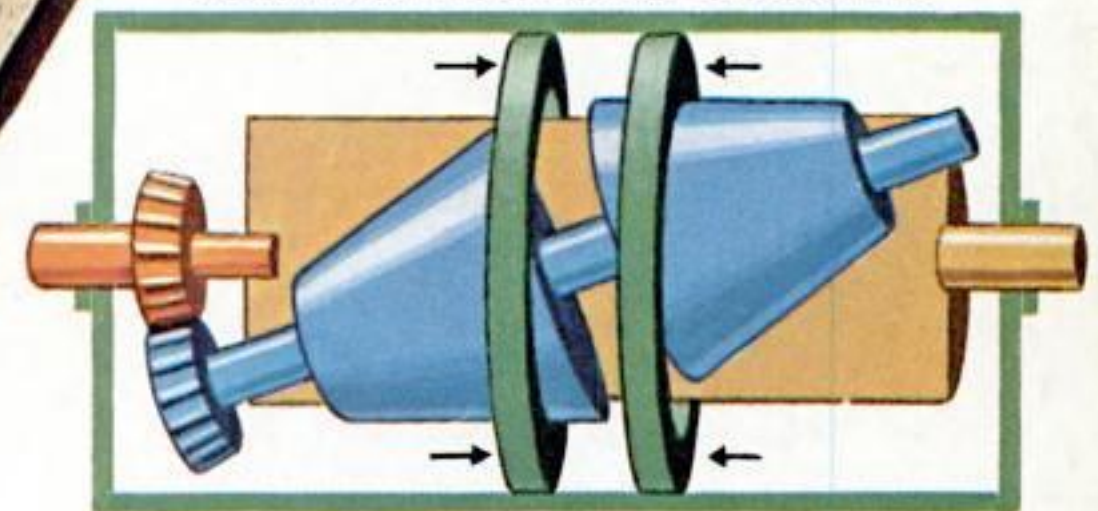

MINIMUM TORQUE, MAXIMUM SPEED

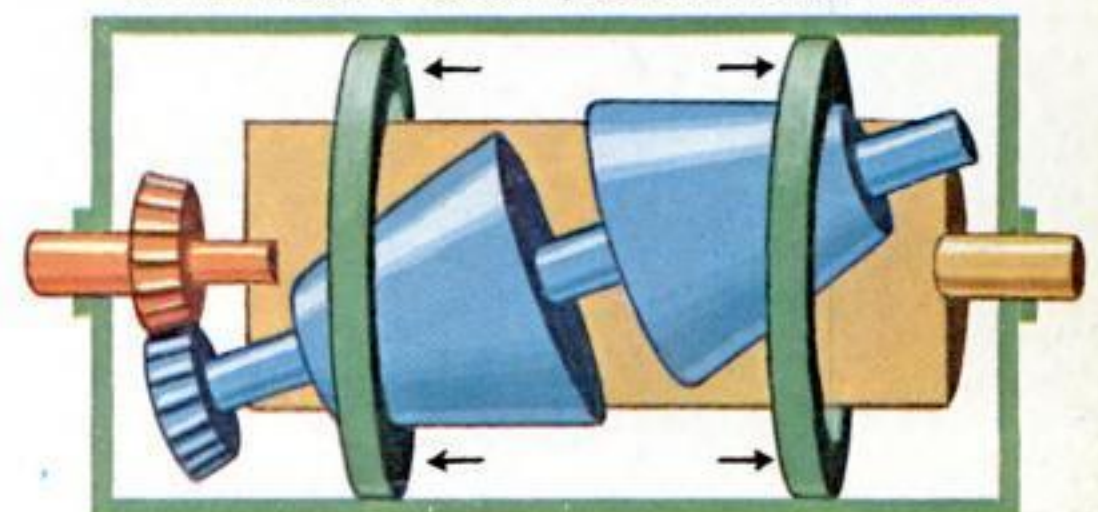

For your yard: new **STRING TRIMMERS, MOWERS,** even **DIESEL TRACTORS**



Why did Dave Lewis choose the Kawasaki KZ1000 LTD with its exclusive Clean Air System?

Because Dave believes in full power when making a pass.

Dave was impressed with Kawasaki's ability to meet the EPA standards without loss of power. In fact, he appreciated the improved acceleration, the stable idling and the short warm-ups that the unique Clean Air System gave him.

But the real truth is, Dave Lewis bought the KZ1000 LTD because he had no choice. The mean, low-down, both feet on the ground stepped seat; the low, fat rear tire; the teardrop fuel tank; the pullback handlebars; he couldn't resist. Of course, with his friends, Dave was quick

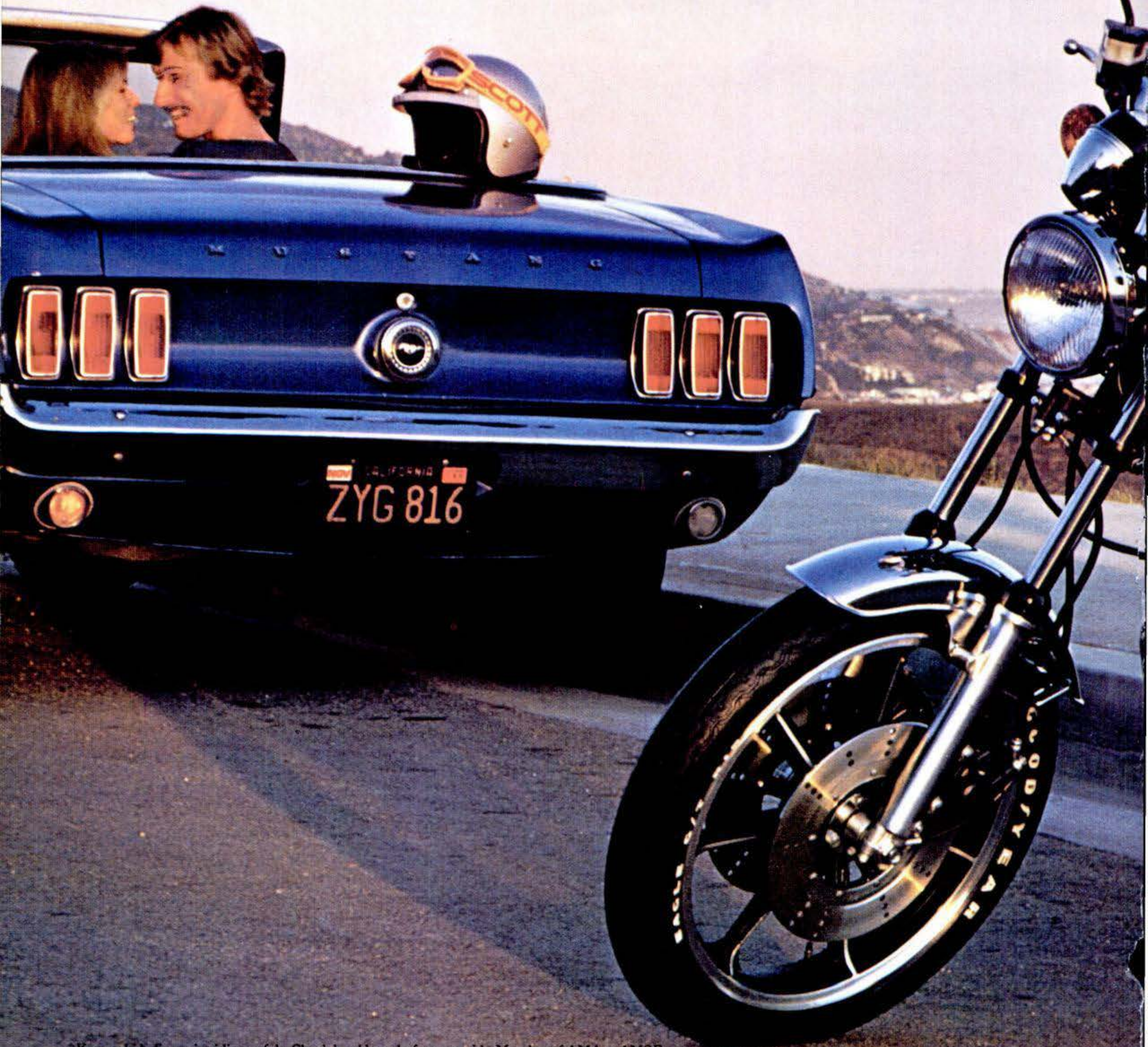

Kawasaki believes in riding safely. Check local laws before you ride. Member of AMA and MSF. Specifications and parts subject to change without notice. Some model availability may be limited.

to point out how reliable the 1015cc engine was; that it was easy to maintain with its transistorized breakerless ignition. He raved about the way it handled and the excellence of the three drilled disc brakes. He would mention that his was the engine that holds most major drag records and the world land speed record.

Then a lady would pass by and smile. As he smiled back, Dave knew why he bought the KZ1000 LTD.

Come and check out the KZ1000 LTD at your local Kawasaki dealership and while you're there make a pass at the other LTDs. 'Cause they've got the power to keep you out there looking good.



KZ750 LTD (FOUR)



KZ750 LTD (TWIN)



KZ650 LTD



KZ550 LTD

Kawasaki

Don't let the good times pass you by.

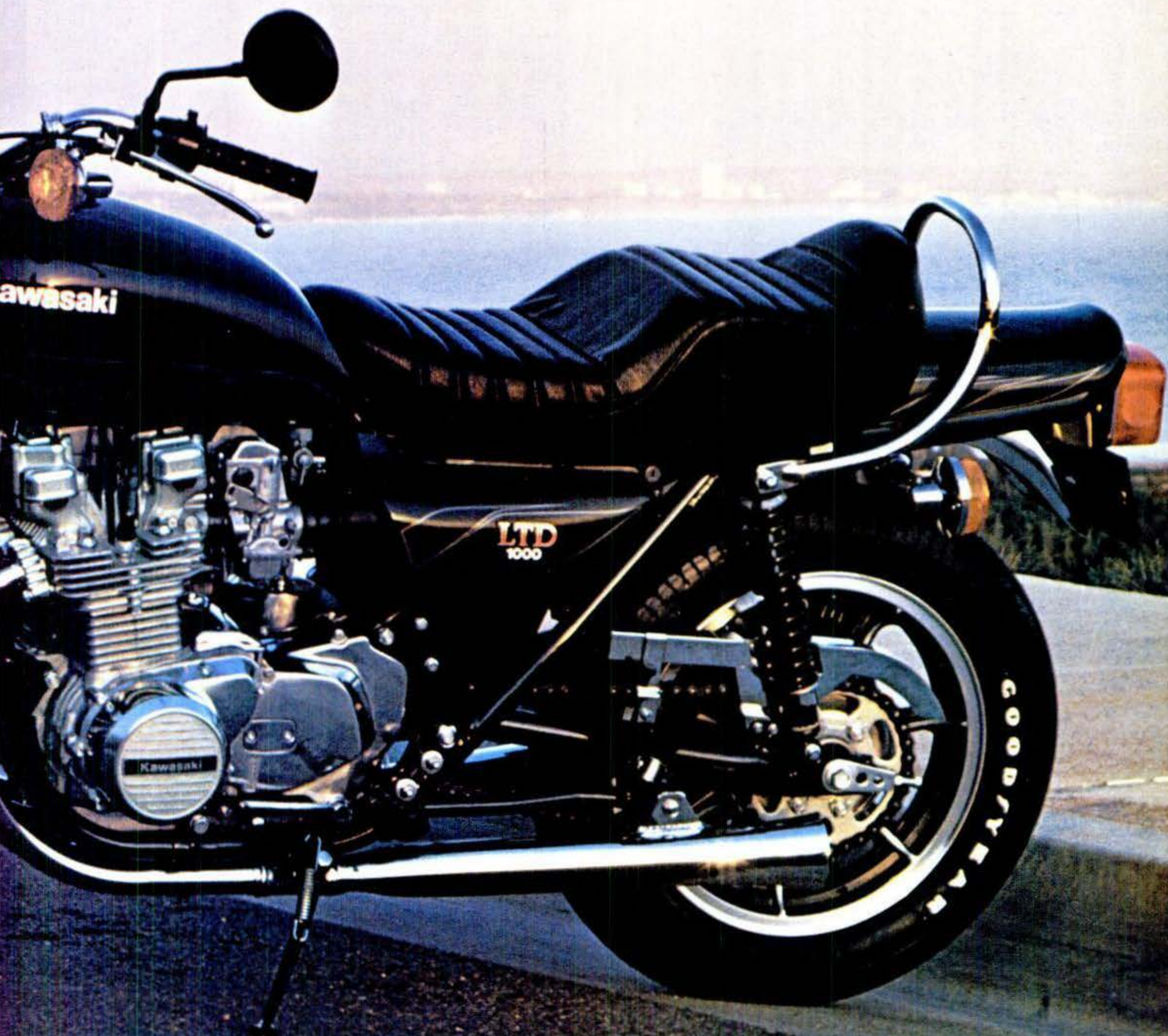

The most fuel-efficient wagon built in America.

The 1980 Mercury Zephyr wagon from Lincoln-Mercury.

Now that you know the 1980 Zephyr wagon from Lincoln-Mercury delivers the best gasoline mileage ratings of any wagon built in America, you should also know how good it really is.

| STATION WAGON | EPA EST. MPG | EST. HWY. MPG |
|------------------|--------------|---------------|
| MERCURY ZEPHYR | 23 | 38 |
| BUICK CENTURY | 20 | 27 |
| OLDS CUTLASS | 20 | 27 |
| CHEVY MALIBU | 20 | 26 |
| PONTIAC LeMANS | 19 | 26 |
| PLYMOUTH VOLARE | 16 | 24 |
| DODGE ASPEN | 16 | 24 |
| DODGE DIPLOMAT | 16 | 23 |
| CHRYSLER LeBARON | 16 | 23 |

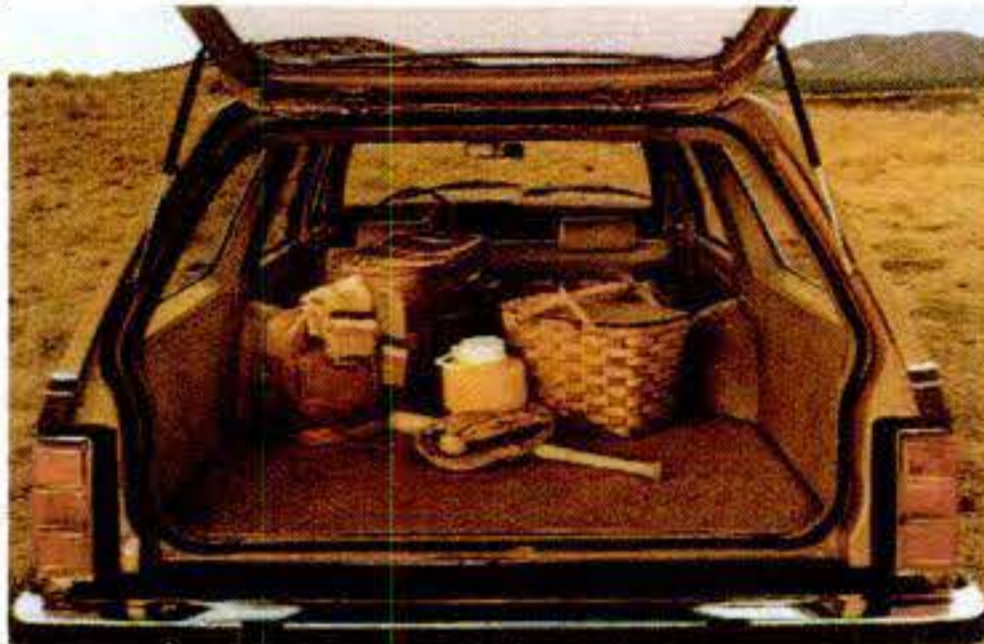

exclude other Ford Motor Company products, and should be used for comparison. But compare these official Government EPA mileage ratings to those of any other maker's wagons of the same size, and you'll see that

none of them compare to Zephyr. Compare Zephyr's low sticker price to any wagon from Buick, Oldsmobile or Pontiac, and you'll see there's no comparison. Compare Zephyr's generous cargo space with any other wagon in its class, from any other maker, and you'll see there's no comparison. Compare Zephyr's excellent

You should also know that the 1980 Zephyr wagon is estimated at more miles per gallon than a total of 8 different Datsun and Toyota models, including wagons and sedans.

Of course your mileage can vary, depending on how fast you drive, weather conditions and trip length. Your actual highway mileage will probably be less than estimated, as will California ratings. And these figures

combination of fuel efficiency, comfort and quality and you'll see the Lincoln-Mercury difference. There's just no comparison.



Mercury Zephyr.
One of the High Mileage Mercurys.

BUY OR LEASE AT THE SIGN OF THE CAT.



MERCURY ZEPHYR

LINCOLN-MERCURY DIVISION



Popular Science

MARCH 1980
Founded in 1872/Vol. 216, No. 3

MONTHLY®

The **What's New** magazine

HIGHLIGHTS OF THIS ISSUE

Traction-drive transmission

This wobbling-cone system could yield a *big* jump in fuel economy. PAGE 83

Install a backyard antenna for satellite TV

With a three-meter dish, programming choices are almost unlimited. PAGE 122

Alcohol fuels—can they replace gasoline?

The technical problems are solvable. But what about the economic ones? PAGE 25

Colliding-beam accelerators seek ultimate particles

Huge new particle smashers race to find the fundamental facts of nature. PAGE 72

Special section: outdoor power equipment

New-for-'80 mowers, mulchers, trimmers, tractors, and more. STARTS PAGE 88

COVER PAINTING BY RAY PIOCH

CARS AND DRIVING

- PS car test: four-wheel drives for go-anywhere performance . . . 39
Traction-drive transmission: It's infinitely variable, saves energy . . . 83
At last—EPA tests reveal the truth about gas-saving devices . . . 117
Trouble-shooting your car's charging system . . . 132

ENERGY NEWS

- Alcohol fuels—can they replace gasoline? . . . 25
Solar salts: New chemical systems store the sun's heat . . . 49
Allison's wind engine—spiraled blades for high efficiency 64

NEW TECHNOLOGY

- Pumping uranium from underground wells . . . 16
Will colliding-beam accelerators reveal the ultimate particles? . . . 72

ELECTRONICS

- Install a backyard antenna to tune in satellite TV . . . 122

NEW PRODUCTS AND INVENTIONS

- Fast-talking cassette player . . . 69
Remote blackboard broadcasts lessons . . . 70

OUTDOOR POWER EQUIPMENT 12-PAGE SPECIAL SECTION

- New yard trimmers: more gas power, tougher string cutters . . . 88
Mowers for 1980—rear-baggers take over . . . 91
Grass clippings vanish under mulching mowers . . . 94
Three lawn/garden diesel tractors 96
Dual-range tractor . . . 97
Car-powered log splitter. . . tough new 16-horse tractors. . . tillers . . . 98
Rubber blade cuts grass, not shoes . . . 99
Portable power for yard work . . . 99

OUTDOOR RECREATION

- Back-country gear—clever tents, packs, cookers, and more . . . 77
How to get the best buy in a 10-speed bike . . . 80
'80 RV's—here come the lightweights . . . 108

What's New DIGEST

- Paratroopers' helicopter . . . 100
Hydroponic dome . . . 101
What's new in photography . . . 102
What's new in boating . . . 103
What's new in home improvement 104
What's new in tools . . . 105
What's new in electronics . . . 106
What's new for your car . . . 107

HOME AND YARD

- Construct your own growing machine . . . 87
PS leisure home: woodstove cottage . . . 111
Here are the 10 winners of our FRP project contest . . . 112
Shelter fence and kindling bin . . . 120
Invisible doors on pipe hinges . . . 150
Maybe you've been neglecting dishwasher maintenance . . . 154
Make a keyless lock . . . 181

TOOLS AND TECHNIQUES

- Weld aluminum at home or anywhere . . . 124
No-glue doweling . . . 195

REGULAR FEATURES

- PS readers talk back . . . 4
Science newsfront . . . 12
Calcu-letter . . . 20
Recreation roundup . . . 52
Look and listen . . . 57
New ideas from the inventors . . . 58
Alternate-energy answers . . . 61
Detroit report . . . 63
PS/What's news . . . 71
Taking care of your car . . . 144
"Say, Smokey—" . . . 146
Shop talk . . . 148
Wordless workshop . . . 153

EDITORIAL OFFICES 380 Madison Avenue, New York, N.Y. 10017

Published monthly by TIMES MIRROR MAGAZINES, INC., 380 Madison Avenue, New York, N.Y. 10017

SUBSCRIPTION SERVICE (Only mail regarding subscriptions should be sent to Boulder, Colo., address below). *New or Renewal Orders:* Send to: Popular Science Subscription Department, Boulder, Colo. 80302. One year \$9.94, 2 years \$15, 3 years \$20 in U.S. and its possessions. One year \$13.94, 2 years \$20, 3 years \$28 in Canada and elsewhere. Single copy \$1.50. *Subscription orders processed electronically. All subscription adjustments:* Write to Robert Harlan, Popular Science, P. O. Box 2871, Boulder, Colo. 80302. For change of address allow eight weeks; please give both old and new addresses. Notices of undelivered copies (Form 3579) to Mr. Harlan. Controlled-circulation postage paid at Effing-

ham, Ill. Publication number 493730. Popular Science is entered as second-class matter at the Post Office Department Canada. Microfilm editions are available from University Microfilms, Ann Arbor, Mich. 48106. ADVERTISING OFFICES New York: 380 Madison Ave. (10017), Tel. 212-687-3000; Chicago: 875 N. Michigan Ave. (60611), Tel. 312-337-7717; Detroit: 19075 W. 10 Mile Rd., Southfield, Mich. (48075), Tel. 313-352-8333; Los Angeles (Pacific West Coast): 3550 Wilshire Blvd., Suite 908 (90005), Tel. 213-380-1936. *Mechanics and Handicraft* ® Popular Science ® Copyright © 1980 by Times Mirror Magazines, Inc. All rights reserved. Printed in U.S.A.

Editor-in-Chief Hubert P. Lockett
Editor C. P. Gilmore
Executive Editor Everett H. Ortner
Art Director W. David Houser
Copy Chief David D. Vigren

GROUP EDITORS

Arthur Fisher *Science & Engineering*
Herbert Shuldiner *Consumer Information*
Alfred W. Lees *Reader Activities*

SENIOR EDITORS

Jim Dunne *Automotive*
John Free *Technology*
William J. Hawkins *Electronics*
E. F. Lindsley *Engineering*
Richard L. Stepler *Home & Shop*

ASSOCIATE EDITORS

Paul Bolon, Ray Hill, Edwin C. Jacobs (*Automotive*),
Susan Renner-Smith, V. Elaine Smay

Copy Editors: Alice Garrard, Daniel J. Ruby
Art Editors: John F. Crowley, Richard J. Meyer
Art Associate: Hugo Salhuana
West Coast Editor: Jim Schefter
Southeast Editor: Evan Powell
European Editor: David Scott
Editorial Assistants: Jane M. Kleintob (Chief),
Harriet Brown, Eleanor Freebern,
Kathleen Murphy Lord, Edward Moslander
Production Manager: Henry W. Kazmirowski
Business Manager: Anna Dallas

ADDRESS EDITORIAL MAIL to
Popular Science Editorial Dept.
380 Madison Ave., New York, N.Y. 10017

We cannot be responsible for loss of unsolicited queries, manuscripts, or photos. They will not be returned unless accompanied by return postage. We welcome readers' comments, but regret that the volume of mail does not permit us to answer each letter individually.

CONSULTING EDITORS

Jim Schefter, *Space*
Edwin A. Link, *Oceans*
Jan P. Norbye, *Automobiles*
A. J. Hand, *Photography*
Smokey Yunick, *Auto Mechanics*
Jackson Hand, *Home Improvement*
Robert Gannon, *Adventure*
Phil McCafferty, *Projects*
R. J. De Cristoforo, *Tools & Techniques*
Richard Day, *Home & Shop*
Ben Kocivar, *Flying*
Paul Wahl, *Guns*
Robert Black, *Boating*

F. X. WILKINSON *Vice-President, Publisher*
FRANK MARSHALL *Advertising Manager*
MILTON J. NORCROSS *Circulation Manager*

Published monthly by
TIMES MIRROR MAGAZINES, INC.,
380 Madison Avenue, New York, N.Y. 10017
A Times Mirror Company

ISSN 0161-7370

MATTHEW T. BIRMINGHAM JR.
Chairman of the Board
JOHN A. SCOTT *President*
GORDON B. HALL JR. *Senior V.P.*
ARTHUR H. LOOMIS, *Vice President*
HUBERT P. LUCKETT *Editorial Director*
ADELE BOWERS *V.P. Book Division*
PETER CALVO *V.P. Production*
ROBERT D. COLE *V.P. Circulation*
THOMAS J. GARRISON *Treasurer*

PS READERS TALK BACK

Address letters for this column to: **Readers Talk Back, 380 Madison Ave., New York, N.Y. 10017.** Because of the large volume of mail, we are unable to acknowledge unpublished letters.

Double-shell house

Referring to your highly provocative article on double-shell houses [Dec. '79]: The claim of 90 percent fuel savings is almost too good to be true. That is, until the real reason for this economy is discovered. True, solar insolation helps. But this design would work in comparatively sunless regions. The actual benefactor is that immense heat sink under our feet.

The author of the article assumed that, somehow, heated air from the attic area was being convected downward to the basement where the ground acted to store and release this heat. Think of that! The laws of physics have been repealed! It has always been accepted that warmed gases rise, while cooled gases descend. The end result is referred to as stratification, and the process is known as convection.

What is contributing to the phenomenal energy efficiency of this building? It's simple. Conventional wall designs permit—even with good insulation—convection-current flow of air cooled by the outer walls, to circulate and cool the inner walls, which lose heat to this air. This double-shell house breaks the cycle by permitting the cooler air to circulate through the basement/crawl space, where it becomes tempered, before returning to the inner walls. If the inner walls are insulated, the effect is the same as placing the house in a milder climate, or underground. Since most people prefer to live above ground, it makes good sense to bring these benefits to the house, rather than bring the house to the source of these advantages.

Richard H. Tice, Brooklyn, N.Y.

The fact that we do not thoroughly understand the Lee Porter Butler envelope house is not surprising, given the fact that even the most complex computer modeling of standard home design but scratches the surface of the complex energy flux going on. One very apparent fact, however (but overlooked by author Ron Dans and seemingly the experts he consulted),

is that the temperatures within the shell, though considerably higher than ambient, are generally 15 to 20 degrees below interior house temperature. This means that the solar collector (greenhouse) can be allowed to operate at considerably lower temperatures than would be necessary were this heat being fed directly into the interior living space or directly to storage. Given that the efficiency of any solar collector is inversely proportional to the delta T (temperature difference), this means that the collection system can operate at an efficiency of 30 to 60 percentage points above most passive systems in the colder areas of this country. The question then arises: Can this lower temperature rise drive the passive convective loop necessary for heat transfer? Herein lies much room for research and reliable modeling.

Tom Wilson, Upper Black Eddy, Pa.

Gravity and acceleration

Having burdened myself with a degree in English more than a decade ago, my knowledge of Dr. Einstein's theories is limited to the content of your recent article on that subject ["After 63 Years, Why Are They Still Testing Einstein?" Dec. '79]. It left me with many questions, but I shall be bold enough to refute only the "principle of equivalence."

In the elevator experiment the apparent force of gravity is unidirectional and parallel with the axis of motion of the elevator. It has no apparent center of origin. Plumb bobs hung from a rod at the top of the elevator would all hang in parallel lines. This contradicts our experience on Earth where the force of gravity is omnidirectional and emanates from a common center of origin. Contrary to the assumptions of our building contractors, plumb bobs hung from various points above the Earth are not parallel. They all point to a common center and form lines coincident with the radii of the Earth. Because of this fact, a plumb bob at the equator will form a right angle with one at the North Pole.

Continued

POPULAR SCIENCE READER SERVICE Check below to report a change of address. Or to get more mail. Or less mail.

| | | |
|---------|-------|----------|
| Name | | |
| Address | | |
| City | State | Zip Code |

It helps if you attach your address label (or copy your name and address exactly as they appear on your label) in the space above.

- MOVING NOTICE. Put your old address at left, your new one at right. (Please give us six weeks' notice.)
- UNLISTING SERVICE. Check here if you don't want to receive mail from advertisers who use the POPULAR SCIENCE list. (Be sure to attach your label at left.)
- LISTING SERVICE. Check here if you're not a subscriber but want to receive mail from advertisers who use the POPULAR SCIENCE list. (Be sure to fill in your name and address at right.)

| | | |
|---------|-------|----------|
| Name | | |
| Address | | |
| City | State | Zip Code |

POPULAR SCIENCE, P.O. Box 2871,
Boulder, Colo. 80302.

**Some of the best things
are measured by the ounce.**

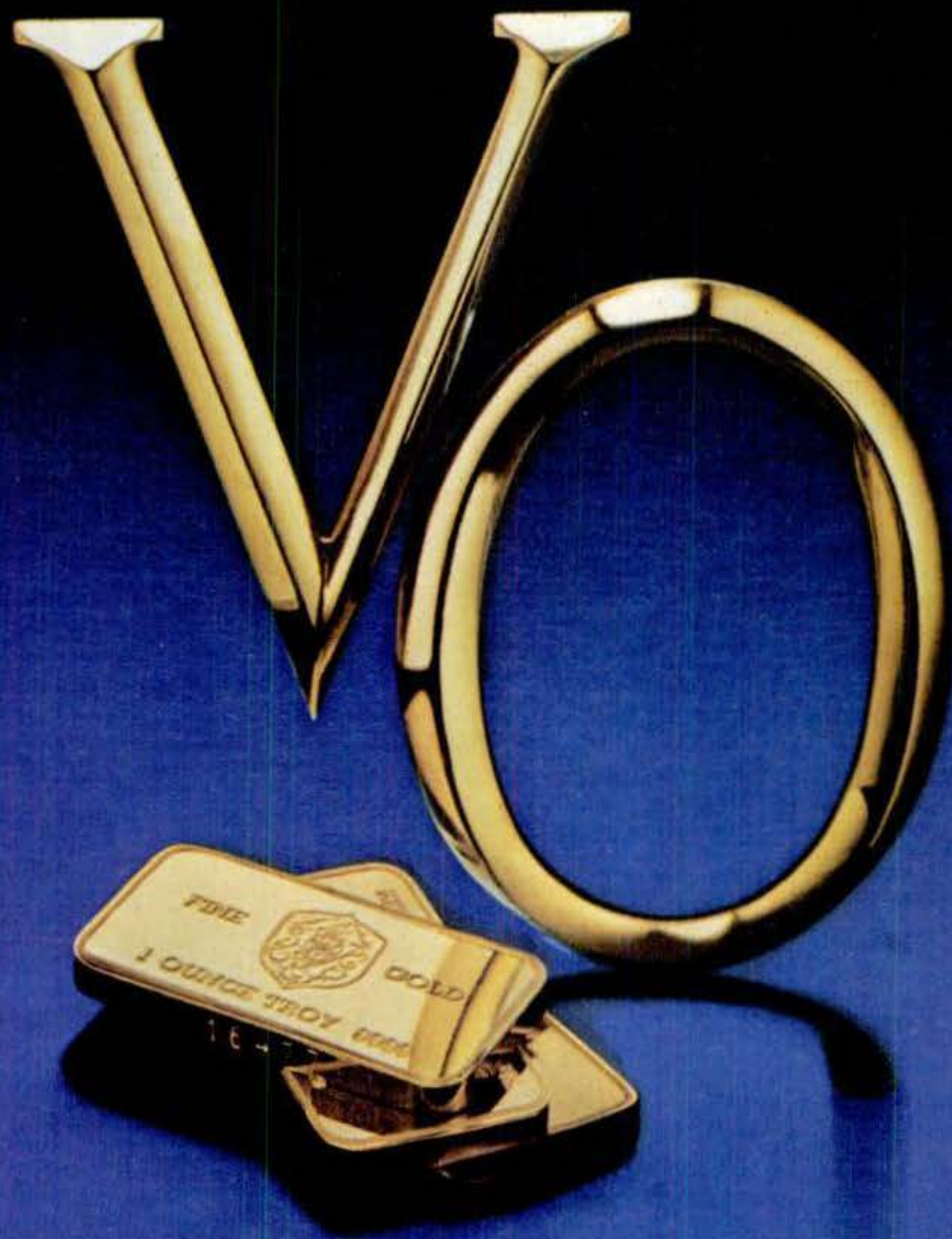

Seagram's V.O.
The symbol of imported luxury. Bottled in Canada.
Enjoy our quality in moderation.

Canadian whisky: A blend of Canada's finest whiskies. 6 years old. 86.8 Proof. Seag

This One



89HB-R73-NWYH

Copyrighted materi

FIGHT BACK AGAINST SO-CALLED PLANNED OBSOLESCENCE

SCOUT[®] INTRODUCES THE WARRANTY PACKAGE IN

It seems like clockwork. Just when the repair bills start rolling in, you discover your car's warranty has run out. Call it planned obsolescence. Call it anything you want. At International Harvester, we call it disgraceful.

That's why for 1980 we proudly and confidently announce the longest engine and rust-through protection package in automotive history: 100,000 miles. Or 5 years. Clean and simple.

How to build a 100,000-mile engine warranty.

We build every one of our engines to last well beyond 100,000 miles. That's why we can make this promise: *During the first 100,000 miles, or 5 years (whichever comes first), International[®] Scout[®] will repair or replace without charge for parts or labor any part of the engine block and all internally-lubricated engine components which are defective.**

But it takes more than a good engine to back up a 100,000-mile warranty.

Testing. Unlike most car companies, we test every Scout engine both before and after it's put into the vehicle. And we're very picky about the ones we accept. Our inspectors are probably

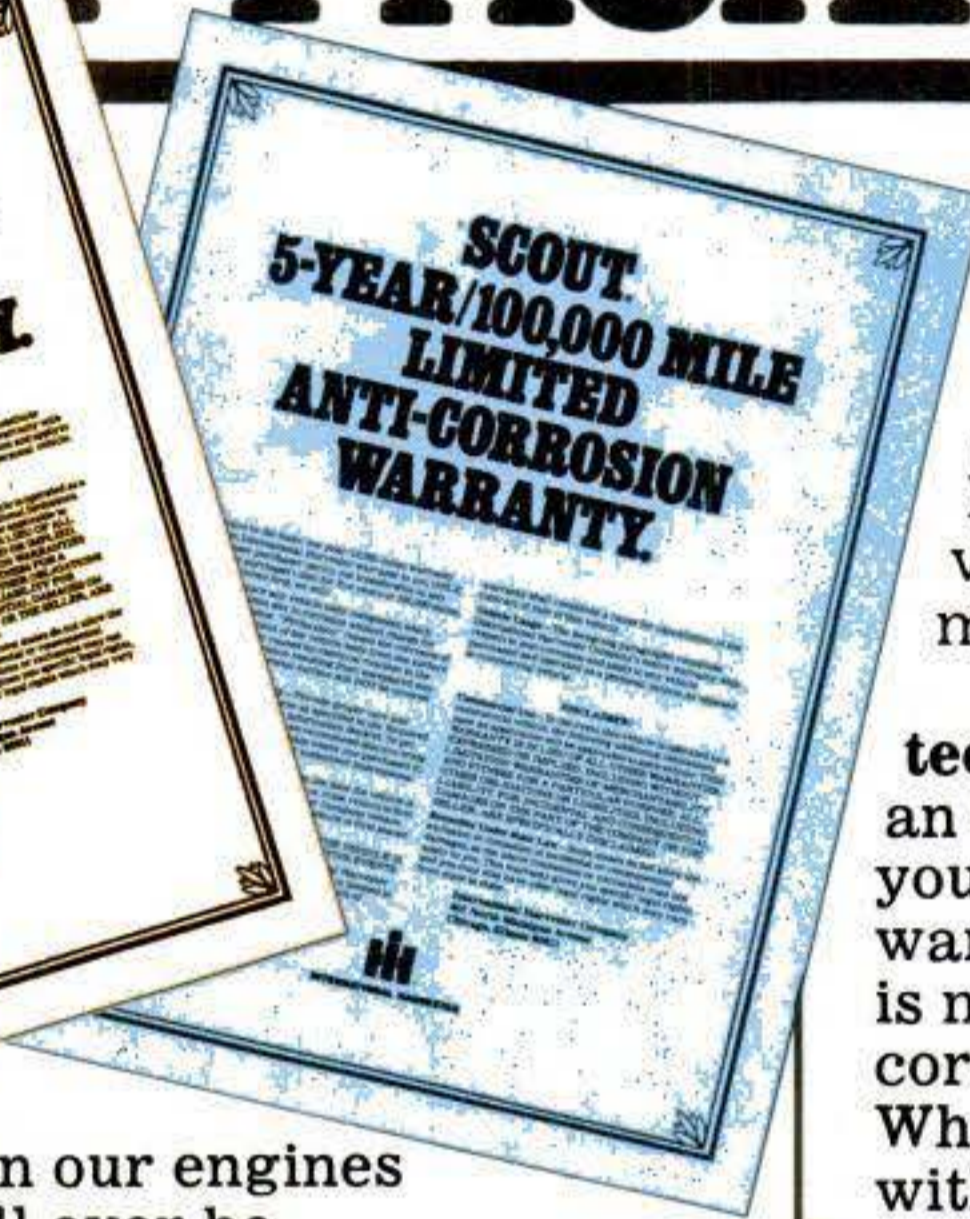
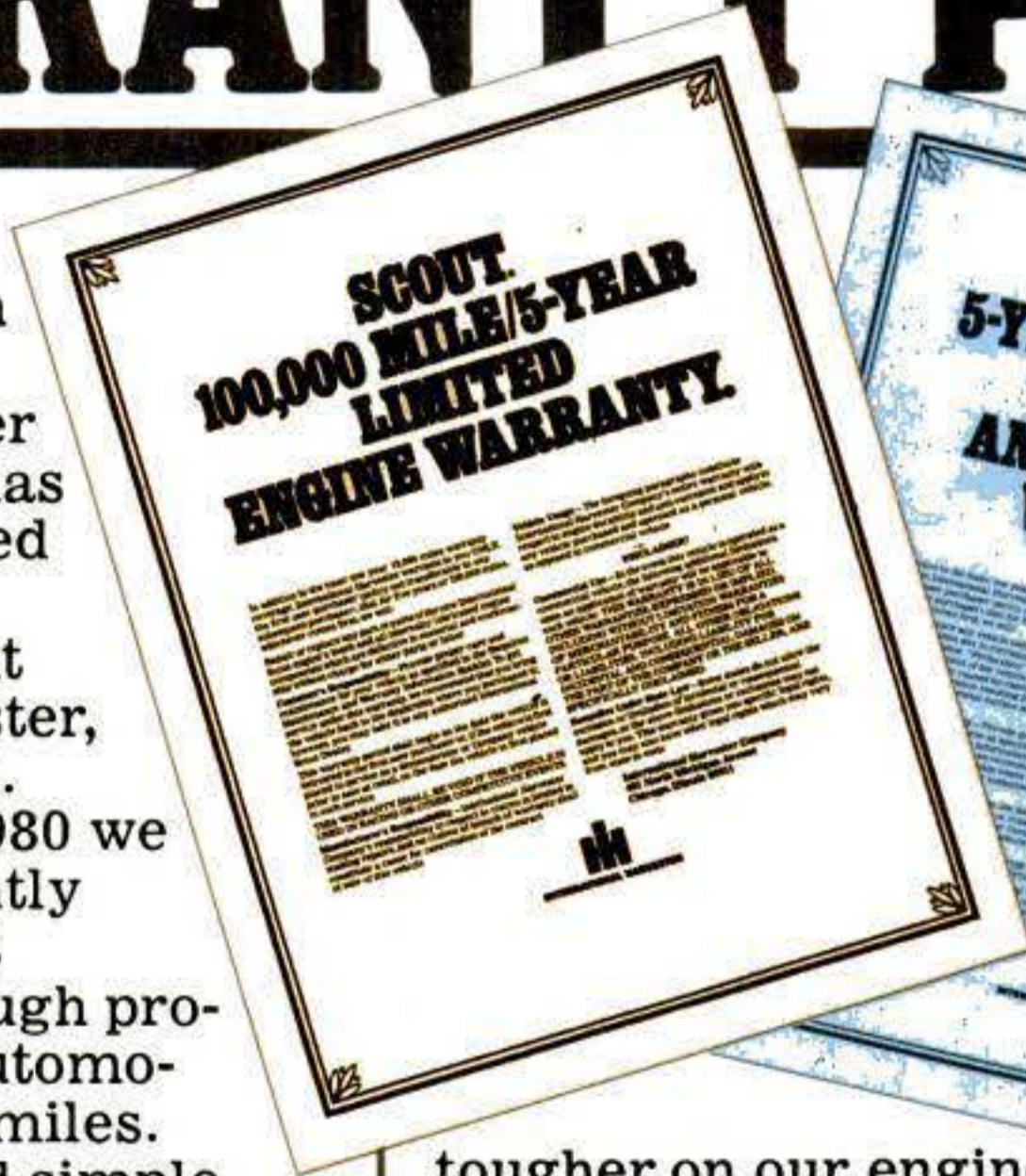
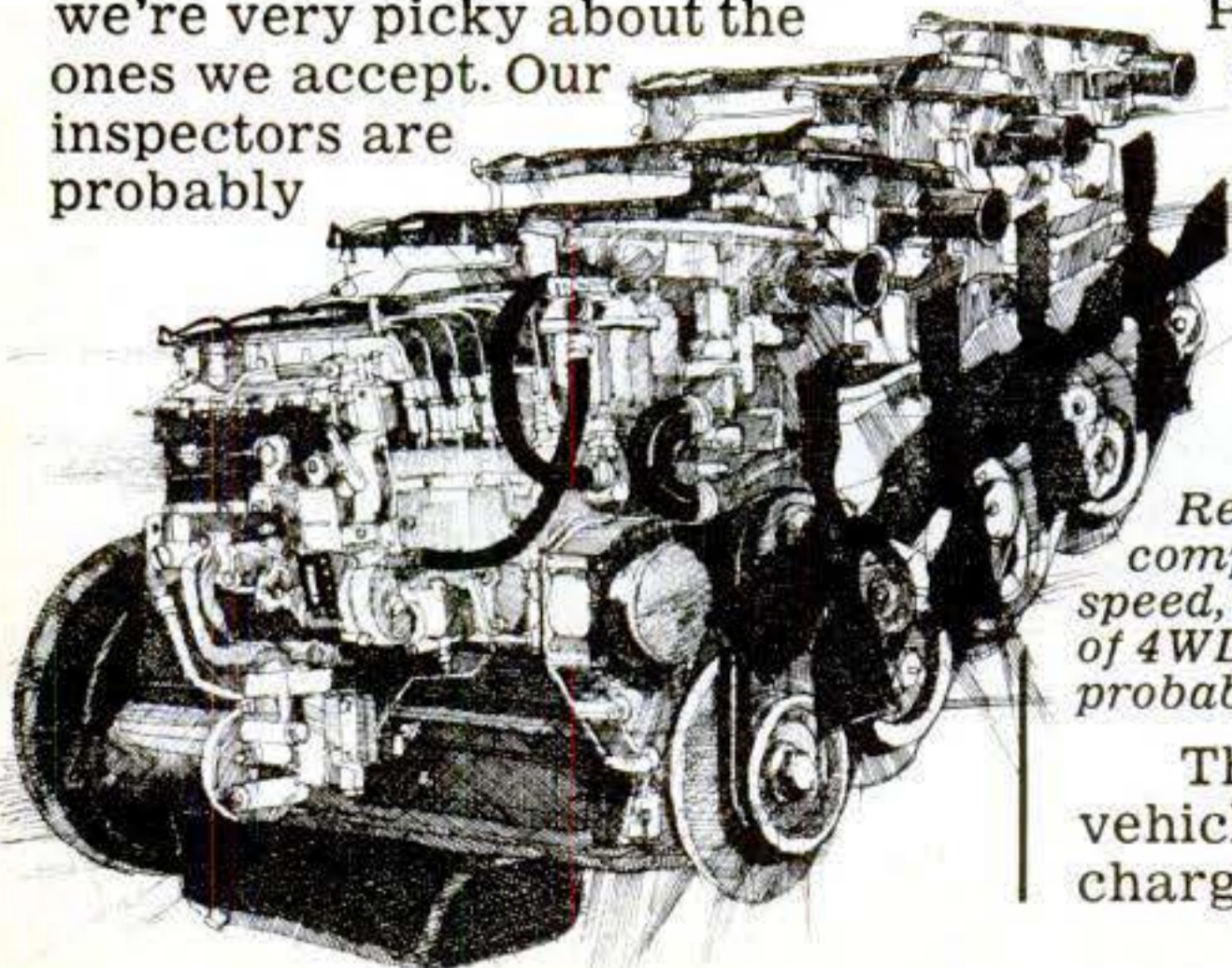

tougher on our engines than you'll ever be.

International Harvester Heritage. We've been building our own engines since 1908. In fact, one of our optional Scout engines is a first cousin to the power plant that goes in our 2½-ton trucks.

And every Scout engine is a 100,000-mile engine. From our gutsy, but economical, 196-cubic-inch four-cylinder to our hardworking, hard-playing 304-cubic-inch and 345-cubic-inch V-8's.

Our new turbo-diesel engine. Only one other in America.

The new Scout Turbo-D gives you all the economy and dependability of a diesel with startling acceleration. Power to pass.

Power to get through trouble. Extra power when you want it—and need it most.

Scout Turbo-D fuel economy:

22 EPA EST MPG **24** EST HWY MPG

Remember, use estimated mpg for comparison only. Mileage varies with speed, weather, trip length and your use of 4WD. Actual highway mileage will probably be less.

There is one other passenger vehicle in America with a turbo-charged diesel: the \$30,000

Mercedes-Benz 300SD.

It's unfair to compare our engine to theirs however. Remember, the more affordable Scout Turbo-D has a 100,000-mile warranty vs. a warranty of only 20,000 miles for the Mercedes.

Our new rust warranty. Protection for the long haul. Drive an ordinary car a few years and you may discover that your rust warranty (if you have one at all) is no more solid than the fast-corroding body of your car.

What do you do? You fight back with Scout. And our new 5-year rust-through protection plan

Our new warranty gives you this honest promise: *During the first 100,000 miles, or 5 years (whichever comes first), International Scout will repair or replace any vehicle body component which suffers "perforation" due to corrosion*



Bill Roseberry is a steady hand behind our hot wax anti-rust treatment.

*without charge for parts or labor.**

We treat every

1980 Scout with an extensive 4-step anti-rust process.

We galvanize critical welding points. Dip Scout bodies to electrostatically coat all major body parts. Apply zinc-rich primer to hood, fender and windshield seams. Finally, we call on the steady hand of Bill Roseberry, who helps hand spray 325° "hot wax" on inner surfaces to protect them against corrosive road salt.

Quality and security go hand-in-hand.

The same built-in quality that is the backbone of our new warranties helps protect you and

*Warranties are non-transferable, and assume customer's proper care and maintenance. See your dealer for details.

LONGEST AND BEST AUTOMOTIVE HISTORY.

our family from things that push ordinary cars to their limits... and beyond. Like 1980-size potholes, flooded roads and hazardous winter driving. In a Scout you'll get a feeling of well-being you may never experience in a car.

It's a secure feeling of sitting in a vehicle that surrounds you with protective steel. Try and find a car that puts more steel between you and trouble than a Scout.

In a Scout you sit higher than in a car. A vantage point that lets you see the road ahead more

clearly and avoid trouble more easily.

Then there's our selective 4-wheel drive. It gives you the option of easily shifting from economical 2-wheel drive to 4-wheel drive, for extra stability and traction when the road or the weather looks rough.

How to fight back.

Your International Scout dealer has just what you need to fight back against the compromise of ordinary car warranties and ordinary cars in general.

The versatile Scout II® and the bigger, roomier Scout Traveler®

Before you even consider buying an ordinary car, test drive a 1980 Scout. It's as easy as dialing 800-IH-SCOUT for your local dealer.

Dial
Toll-Free **800-IH-SCOUT**
Illinois Residents 800-322-0821



INTERNATIONAL HARVESTER



FIGHT BACK WITH SCOUT.

Anything less is just a car.

Six reasons to retire your old slide projector.

The longer you've been into slides, the more a new Kodak Carousel projector has to offer.

Upgrading your projector can upgrade your whole slide collection in one stroke! With our top-of-the-line Kodak Carousel projector, you not only get the reliability Carousel projectors have been famous for over the years, but the many improvements that have come along since.

- Sharp, Ektanar C curved-field lens. Both normal or zoom to choose from. For brighter images with improved edge-to-edge sharpness.
- Automatic focusing. Keeps the show in focus slide after slide.
- Remote control, both forward and reverse. Even remote-focus override. For easier, more comfortable showing and viewing.
- Programmed showing. So you can sit back and relax and let the projector advance the slides at 5-, 8-, or 15-second intervals.
- Transvue 140 tray. So you can pack in a lot more slides.
- Built-in dark shutter latch. So the screen stays dark when no slide is being shown.

With eleven Kodak Carousel projector models to choose from, you can get just what you want in the way of automation, and in the way of price.



1880 **Kodak** 1980
America's Storyteller

Kodak Carousel projectors.

The dependable ones.

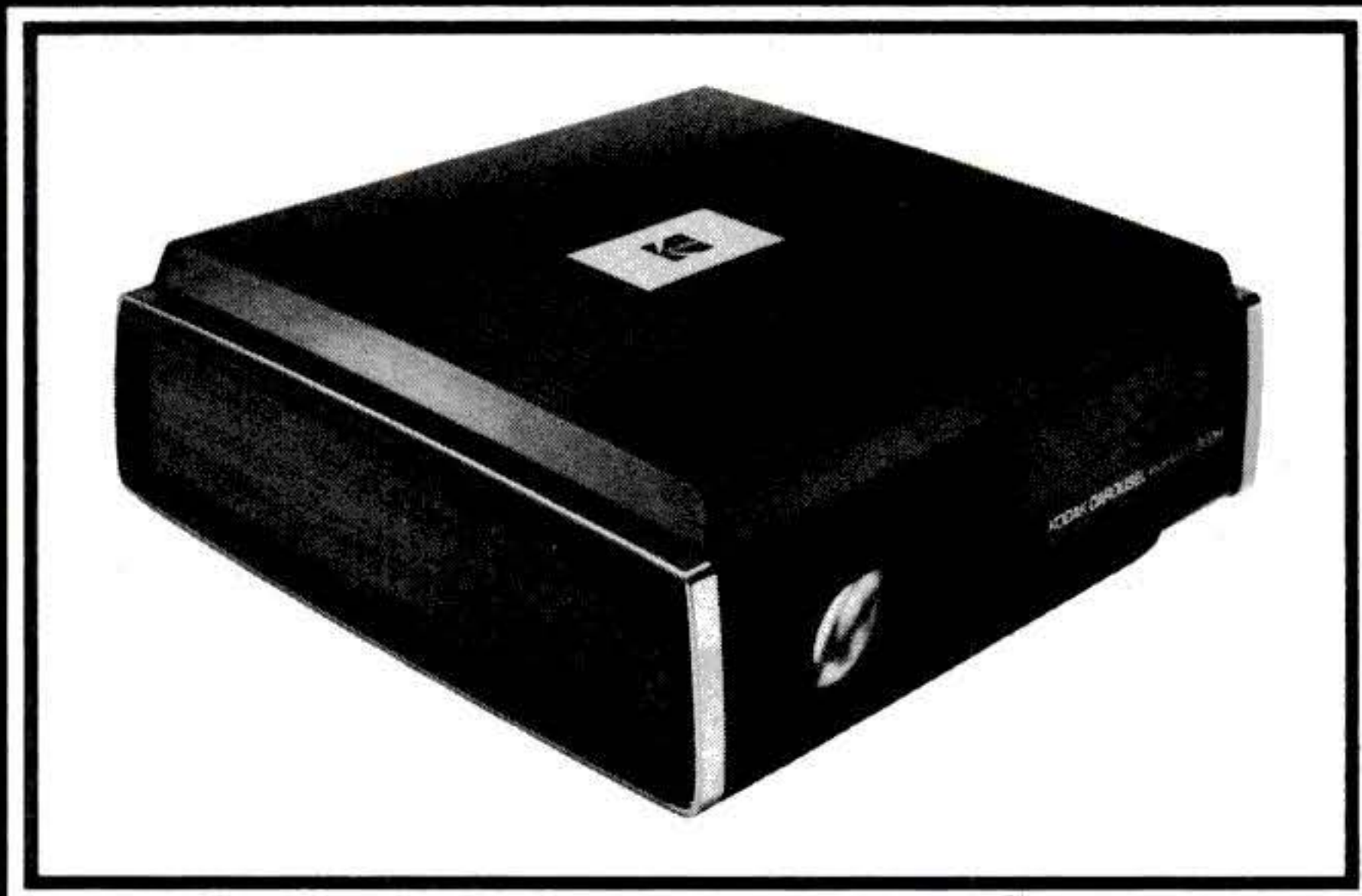

OFFICIAL PHOTO CONSULTANT TO
THE 1980 OLYMPIC WINTER GAMES

© Eastman Kodak Company, 1980

PS readers talk back

[Continued from page 4]

Therefore, there is an experiment which can distinguish the *true force* of gravity from the *apparent force* caused by acceleration. Gravity and acceleration are *not* the same, and if Einstein said they are he was mistaken.

Roger W. Ingalls, Auburn, N.Y.

Snowthrower price controversy

In the article on snowthrowers in the November '79 issue, you state that Sears has made the "advertising mistake of the year" and that one can buy the five-hp model 9182 snowthrower for \$10 less with electric start than with manual start, and the eight-hp model 9184 for \$20 less with electric start. This statement is incorrect. Referring to the Sears catalog, the price of model 9182 is \$10 less "when you buy electric start." The price of the electric starter listed on page 960 would be \$57.45 additional for model 9182 and \$62.45 additional for model 9184. The discounts are allowed only if you purchase the electric start kit.

Julius Dvorak, Jamesburg, N.J.

E.F. Lindsley replies: "When I wrote the story, the Sears catalog was still at the printers. A letter from Sears, dated June 15, 1979, lists upcoming models: 'Second is a mid-priced five-hp snowthrower which sells for \$499.99 or the same snow thrower with an electric-start kit which sells for \$489.99.' This is model 9182. There is absolutely no reference to an additional charge for the starter kit.

"Regarding the eight-hp 9184, the letter says, 'The eight-hp thrower sells for \$779.99 or \$759.99 with the electric-start kit.' Again, no mention of the cost of the kit.

"A phone call to Sears public-relations department about this apparent error brought the reply that a mistake had been made but the catalog was being printed and couldn't be changed; and Sears will stand behind its advertising, I was advised. That's the history of the statement in the article, but what may have finally developed on the retail level was not quite in agreement, judging by reader mail."

Particleboard and formaldehyde

I found it particularly distressing that your two articles on "New-Generation Particleboard" [Dec. '79 and Jan. '80] contained no information about the emission of chemical residue from urea-formaldehyde resins used in the majority of particleboards. While the question of long-term harm is yet unanswered, and short-term discomfort a matter both individual and controversial, both the industry and the scientific community admit what many particleboard consumers have long been aware of: Trace amounts of formaldehyde "outgas" in even slightly moist areas at moderate temperatures, and "outgassing" increases as temperature and/or moisture levels increase.

Apparently, the major questions yet to

Continued

Burglar Alarm Breakthrough

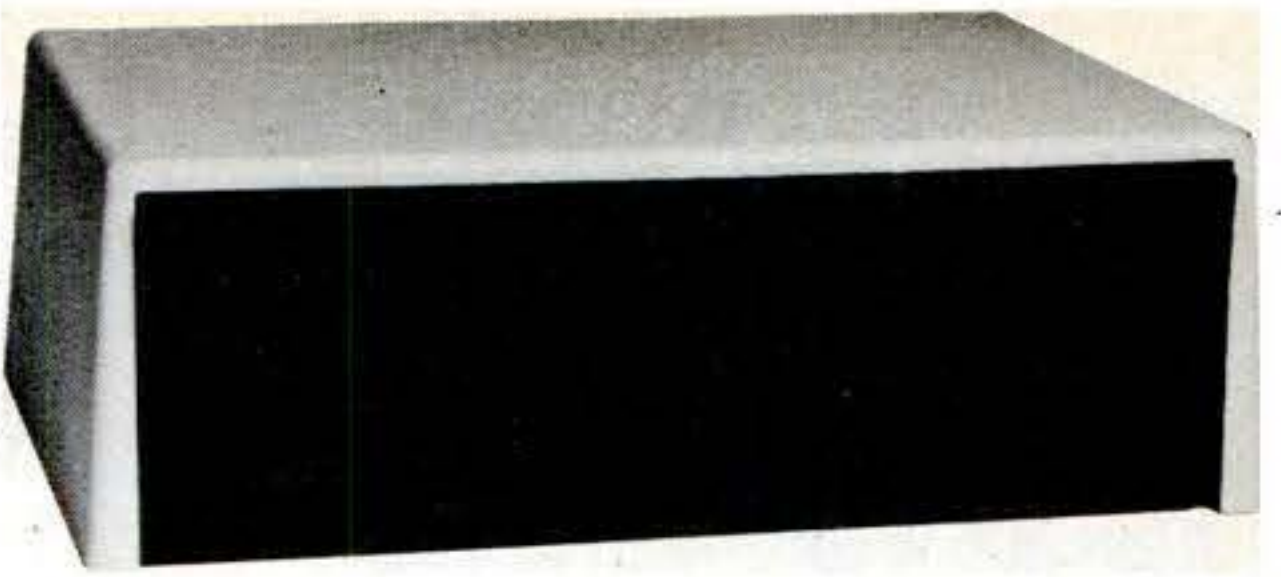

A new computerized burglar alarm requires no installation and protects your home or business like a thousand dollar professional system.

It's a security system computer. You can now protect everything—windows, doors, walls, ceilings and floors with a near fail-safe system so advanced that it doesn't require installation.

The Midex 55 is a new motion-sensing computer. Switch it on and you place a harmless invisible energy beam through more than 5,000 cubic feet in your home. Whenever this beam detects motion, it sends a signal to the computer which interprets the cause of the motion and triggers an extremely loud alarm.

The system's alarm is so loud that it can cause pain—loud enough to drive an intruder out of your home before anything is stolen or destroyed and loud enough to alert neighbors to call the police.

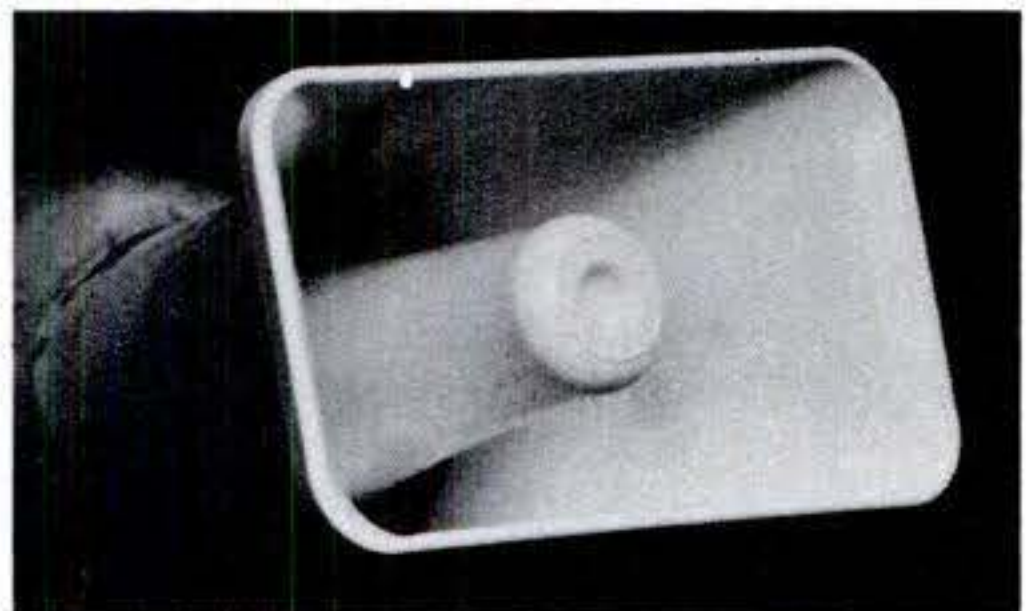

The powerful optional blast horns can also be placed outside your home or office to warn your neighbors.

Unlike the complex and expensive commercial alarms that require sensors wired into every door or window, the Midex requires no sensors nor any other additional equipment other than your stereo speakers or an optional pair of blast horns. Its beam actually penetrates walls to set up an electronic barrier against intrusion.

NO MORE FALSE ALARMS

The Midex is not triggered by noise, sound, temperature or humidity—just motion—and since a computer interprets the nature of the motion, the chances of a false alarm are very remote.

An experienced burglar can disarm an expensive security system or break into a home or office through a wall. Using a Midex system there is no way a burglar can penetrate the protection beam without triggering the loud alarm. Even if the burglar cuts off your power, the four-hour rechargeable battery pack will keep your unit triggered, ready to sense motion and sound an alarm.

ARRIVE HOME SAFE

There's personal danger in arriving home and finding a burglary in progress. And, if you surprise the burglar, you risk the chance of serious injury. With the Midex 55 protecting your home, you can open your front door with the confidence of knowing that no burglar lurks inside.

When the Midex senses an intruder, it remains silent for 20 seconds. It then sounds the alarm until the burglar leaves. One minute

after the burglar leaves, the alarm shuts off and resets, once again ready to do its job. This shut-off feature, not found on many expensive systems, means that your alarm won't go wailing all night long while you're away. When your neighbors hear it, they'll know positively that there's trouble.

PROFESSIONAL SYSTEM

Midex is portable so it can be placed anywhere in your home. You simply connect it to your stereo speakers or attach the two optional blast horns.

Operating the Midex is as easy as its installation. To arm the unit, you remove a specially coded key. You now have 30 seconds to leave your premises. When you return, you enter and insert your key to disarm the unit. You have 20 seconds to do that. Each key is registered with Midex, and that number is kept in their vault should you ever need a duplicate. Three keys are supplied with each unit.

As an extra security measure, you can leave your unit on at night and place an optional panic button by your bed. But with all its optional features, the Midex system is complete, designed to protect you, your home and property just as it arrives in its well-protected carton.

The Midex 55 system is the latest electronic breakthrough by Solfan Systems, Inc.—a company that specializes in sophisticated professional security systems for banks and high security areas. JS&A first became acquainted with Midex after we were burglarized. At the time we owned an excellent security system, but the burglars went through a wall that could not have been protected by sensors. We then installed over \$5,000 worth of the Midex commercial equipment in our warehouse. When Solfan Systems announced their intentions to market their units to consumers, we immediately offered our services.

COMPARED AGAINST OTHERS

In a recent issue of a leading consumer publication, there was a complete article written on the tests given security devices which were purchased in New York. The Midex 55 is not available in New York stores, but had it been compared, it would have been rated tops in space protection and protection against false alarms—two of the top criteria used to evaluate these systems. Don't be confused. There is no system under \$1,000 that provides you with the same protection.

YOU JUDGE THE QUALITY

Will the Midex system ever fail? No product is perfect, but judge for yourself. All components used in the Midex system are of aerospace quality and of such high reliability that they pass the military standard 883 for thermal shock and burn-in. In short, they go through the same rugged tests and controls used on components in manned spaceships.

Each component is first tested at extreme

The Midex security computer looks like a handsome stereo system component and measures only 4" x 10½" x 7."

tolerances and then retested after assembly. The entire system is then put under full electrical loads at 150 degrees Fahrenheit for an entire week. If there is a defect, these tests will cause it to surface.

PEOPLE LIKE THE SYSTEM

Wally Schirra, a scientist and former astronaut, says this about the Midex 55. "I know of no system that is as easy to use and provides such solid protection to the homeowner as the Midex. I would strongly recommend it to anyone. I am more than pleased with my unit."

Many more people can attest to the quality of this system, but the true test is how it performs in your home or office. That is why we provide a one month trial period. We give you the opportunity to see how fail-safe and easy to operate the Midex system is and how thoroughly it protects you and your loved ones.

Use the Midex for protection while you sleep and to protect your home while you're away or on vacation. Then after 30 days, if you're not convinced that the Midex is nearly fail-safe, easy to use, and can provide you with a security system that you can trust, return your unit and we'll be happy to send you a prompt and courteous refund. There is absolutely no obligation. JS&A has been serving the consumer for over a decade—further assurance that your investment is well protected.

To order your system, simply send your check in the amount of **\$199.95** (Illinois residents add 5% sales tax) to the address shown below. Credit card buyers may call our toll-free number below. There are no postage and handling charges. By return mail you will receive your system complete with all connections, easy to understand instructions and a one year limited warranty. If you do not have stereo speakers, you may order the optional blast horns at **\$39.95** each, and we recommend the purchase of two.

With the Midex 55, JS&A brings you: 1) A system built with such high quality that it complies with the same strict government standards used in the space program, 2) A system so advanced that it uses a computer to determine unauthorized entry, and 3) A way to buy the system, in complete confidence, without even being penalized for postage and handling charges if it's not exactly what you want. We couldn't provide you with a better opportunity to own a security system than right now.

Space-age technology has produced the ultimate personal security computer. Order your Midex 55 at no obligation, today.

JS&A PRODUCTS
THAT
THINK®

Dept. PS One JS&A Plaza
Northbrook, Ill. 60062 (312) 564-7000
Call TOLL-FREE **800 323-6400**
In Illinois Call **(312) 564-7000**

© JS&A Group, Inc., 1978

Sunpak INSTANT READOUT

creative flash has never been so simple



INSTANT READOUT, our new, easy-to-read data display shows only the actual f/stop in use. Another innovation from **SUNPAK. AUTOMATIC POWER** for perfect flash exposures from 27 inches to 28 feet. **POWER RATIO CONTROL** for simple fill-in flash and auto-winder action. **ENERGY-SAVING THYRISTOR CIRCUITRY** means rapid recycling and lots more flash for your battery dollar. Plus **MULTI-POSITION BOUNCE** and more. Available now wherever good cameras are sold.

SUNPAK®
Auto 322 Thyristor



Sunpak Division, Berkey Marketing Companies Box 1102, Woodside, N.Y. 11377
■ 1011 Chestnut St., Burbank, Ca. 91506 ■ In Canada: Sunpak Corporation of Canada, Inc., Ontario

PS readers talk back

[Continued from page 8]

be resolved are: What concentrations are truly safe for humans, and what are the effects of long-term exposure? The growing use of particleboard in the building and furniture industries and its already extensive use in the mobile- and manufactured-home industries makes these questions very pertinent.

Readers interested in more information should refer to: *The Formaldehyde Problem in Wood-Based Products—An Annotated Bibliography* (USDA Forest Service Technical Report FPL-8, 1977, Forest Products Laboratory), a list of both technical and informational references, and *Investigation of Selected Potential Environmental Contaminants: Formaldehyde* (National Technical Information Service PB-256 839), which is detailed but readable.

John R. Lindh, Bellingham, Wash.

Too many threes

I enjoyed your article "Ready Your Range" [Dec. '79] very much. However, I would like to call your attention to an error in the circuitry of the switching of the heating units in the center of page 132. As shown, the switch in position 3 provides a direct short circuit from line "L1" to neutral "N." I believe the circuit closure of the contacts on the extreme left of the diagram should be H1 and 2 (instead of 3).

Franklin A. Korn, Columbus, Ohio
Evan Powell replies: "Good diagnosis. Substituting switch position '3' for '2' at contact L1 not only clears up the short, but gives position 2 a complete circuit across the outer coil of the element."

Heavy crude

Your article on heavy crude in the December '79 issue elaborated many of the problems of using this resource as fuel. I would like to point out an error in the table on page 34.

The line entitled "Carbon by wt. (%)" is in error. The values given are the carbon-to-hydrogen-atom ratios. The percentage of carbon by weight for both crudes is much higher than the numbers given.

Dr. Robert Wagner, Sandusky, Ohio

E. F. Lindsley replies: "A review of more than 80 papers from the Edmonton conference on tar sands and heavy crudes shows that nearly all give the carbon content exactly as shown. This is Conradson or Ramsbottom carbon residue when crude is analyzed and not, as Dr. Wagner suggests, 'carbon-to-hydrogen-atom ratios.' He's correct that an elemental analysis shows, typically, 83.1 percent carbon for bitumen and 86 percent for conventional oil. But the commonly used Conradson number is of more interest to the refiners."

Correction: The Realtime "Skinny Chronograph" shown on page 69 of the December issue is now made 5.8 mm thick rather than 4.7 mm. The lens thickness was increased to reduce breakage.

Case Sharks.

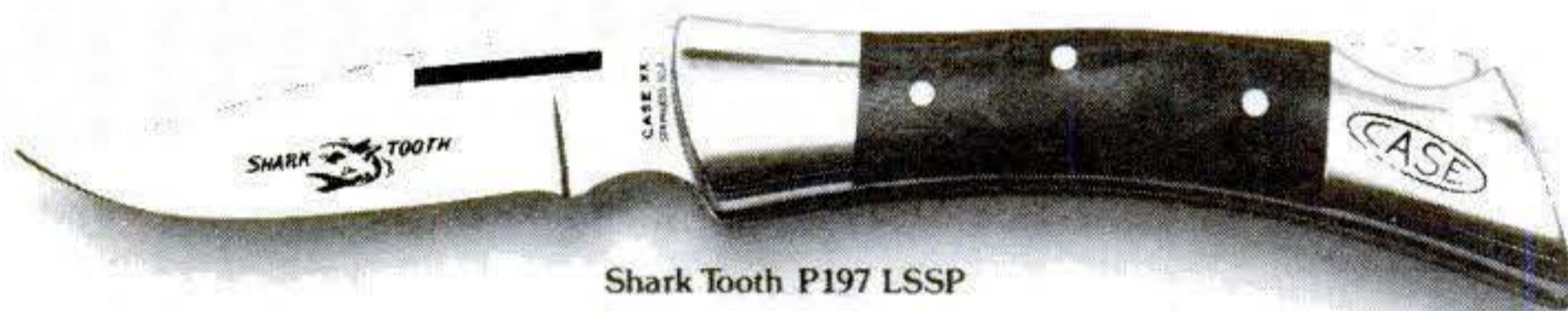

Shark Tooth P197 LSSP



Mako P158 LSSP



Hammerhead P159 LSSP

These three Case Sharks are considered by experts to be among the finest lockblade knives made anywhere — at any price.

More than 150 hand operations go into the making of each knife. For

quality you can see and feel. Brass liners and bolsters give them greater strength. For a lifetime of hard use. Case Sharks can handle any job you can put to a knife.



The world's finest cutlery.
W. R. Case & Sons Cutlery Co. Bradford, PA 16701

NEW TECHNOLOGY

Cordless Wonder

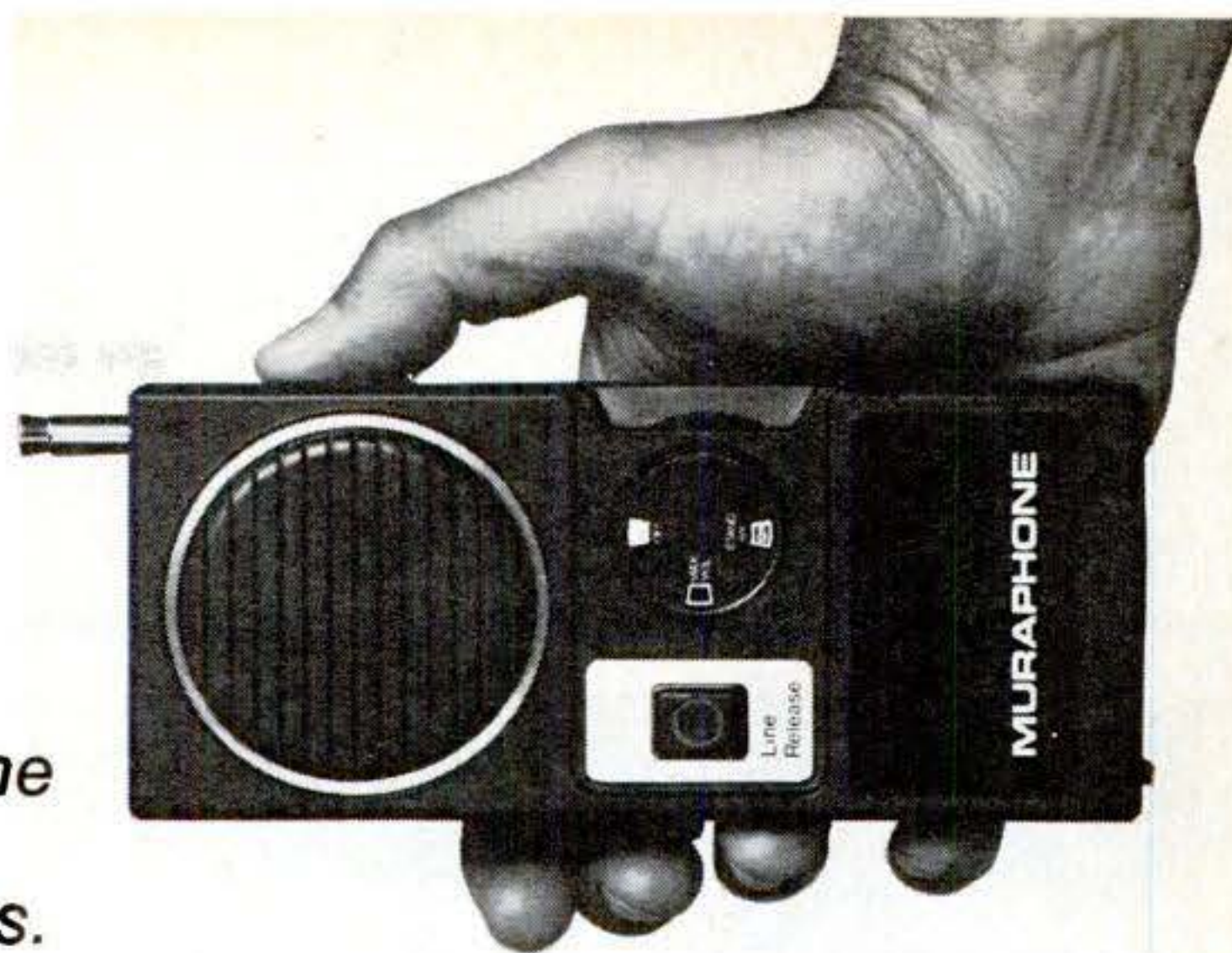

For \$89.95 the Mura cordless telephone sounds like a bargain. But wait until you hear about its many disadvantages.

The Mura cordless telephone represents a major breakthrough in telephone technology.

It's about time. For years you've seen ads for cordless telephones selling for between three and four hundred dollars.

Now through some very clever planning and a sprinkle of new technology, Mura Corporation has come up with a cordless telephone that sells for \$89.95. However, it has major disadvantages that could totally discourage you from buying the system—but more on that later.

ONLY IN AMERICA

The Mura weighs only 12 ounces and measures 1½" x 2¾" x 6½". The system includes a base unit that plugs into your telephone jack. You carry your cordless telephone with you and when your phone rings, you press a button and answer. And you can talk to anyone as long as you remain within 400 feet of the base unit.

But wait. We mentioned that the phone had major disadvantages. And it does. But first, let's outline some of its major advantages. **Convenience** You don't need an extension telephone. With the Pocket Phone you have an extension phone that you can take with you—in the bath, in the den, in the garden, or to your neighbors.

Intercom You can use the base unit to page the person holding the cordless telephone. For example, if you're in your office and someone outside has the unit, you can press a button on the base unit and buzz the portable phone—just like on an intercom. Simply by talking on the phone plugged into your base unit, you can talk with someone on the remote phone. It's ideal for home or factory use.

Price The cost of the Mura remote telephone is only \$89.95. Compare this price not only with the cost of other \$300 remote telephones but with conventional phones as well, and you can appreciate what a major breakthrough the Mura system represents. But there's more.

You can plug any conventional phone into the base unit and carry on a three-way conversation. You can answer a call at the base unit and signal the remote unit to pick up the line. You can cut out the remote phone from the base unit if you want to keep a conversation private.

TALK OF VALUE

You can carry the cordless telephone with you with its antenna collapsed and the battery on standby. When a call beeps your unit, you simply extend the antenna, turn the power on, and start to talk.

The unit is FCC approved for connection directly into your telephone line. If you don't

have a four-pronged jack or a modular connector, simply call your telephone company. They'll promptly install a jack for you and the cost will be around \$15 or less depending on your location.

NOW THE CATCH

We mentioned that there was a catch—a few major disadvantages that you, as the consumer, should know about before you consider purchasing this product. Here they are:

Forget About Dialing The new Mura Pocket Phone can't dial out. It only receives calls. To many people, this doesn't matter because 90% of remote phones are used to receive calls and not to place them. By eliminating the dial, Mura has cleverly saved consumers hundreds of dollars.

Forget About Steel Walls The Mura unit won't penetrate them. This means that if you want to use your phone in a factory with metal walls, your unit won't work. But for most factories and practically all homes, the unit is ideal.

Forget About Snooping The unit has only a 400 foot range. At first this might seem awfully short, but nobody can snoop in on your conversations if that person is beyond this range, and 400 feet is more than enough for most applications. Most cordless telephones operate in the 27 megahertz range—the same frequency area used for citizen band radios.



The base unit for the Mura can also be used as a personal paging system or intercom.

The Mura uses the 49 megahertz range. This frequency has clearer reception with practically no interference.

The above are the disadvantages. For 90% of you, they don't mean a thing. For those 10% of you who need a dial, we would recommend the more expensive cordless telephones.

But for those of you who will accept its disadvantages, you'll be in store for the greatest idea in telephone convenience since the

cordless telephone was first introduced. In fact, rather than install an extension phone, why not consider the Mura instead?

TRY IT FIRST

We suggest you try the Mura Cordless telephone system in your own home, office or factory. Use it for 30 days. Take the phone to your next door neighbor's house or with you to the bathroom while you take a shower or bath. Take it with you on your patio or balcony, or bring it in your garden as you work. Use it in your factory as an intercom or in your office as a remote telephone.

After you've given it a thorough test, then decide if you want to keep it. If not, no problem. Simply return your system for a prompt and courteous refund including your \$3.50 postage and handling. You can't lose.

HERE'S THE WAY

To order your unit for a 30-day test, simply send your check for \$89.95 plus \$3.50 postage and handling to JS&A Group, Inc., One JS&A Plaza, Northbrook, Illinois 60062. (Illinois residents please add 5% sales tax.) Credit card buyers, call our toll-free number below. We'll send your base unit, cordless telephone, rechargeable batteries, recharger, complete instructions, our 90-day limited warranty, and the address of the closest Mura Service Center or service-by-mail station.

Your unit is backed by Mura Corporation, a 17-year old company famous for their microphones, headsets, and other audio products. JS&A is America's largest single source of space-age products—further assurance that your modest investment is well-protected.

Very often when a product's disadvantages aren't made clear to the consumer, that product ends up being a disappointment. By explaining the major disadvantages of the Mura cordless telephone, not only are we avoiding a possible disappointment, we're proving just how great a product it really is. Order a Mura cordless telephone at no obligation today.

JS&A PRODUCTS
THAT THINK®

Dept. PS One JS&A Plaza
Northbrook, Ill. 60062 (312) 564-7000
Call TOLL-FREE 800 323-6400
In Illinois Call (312) 564-7000

©JS&A Group, Inc., 1979

SCIENCE NEWSFRONT

By ARTHUR FISHER

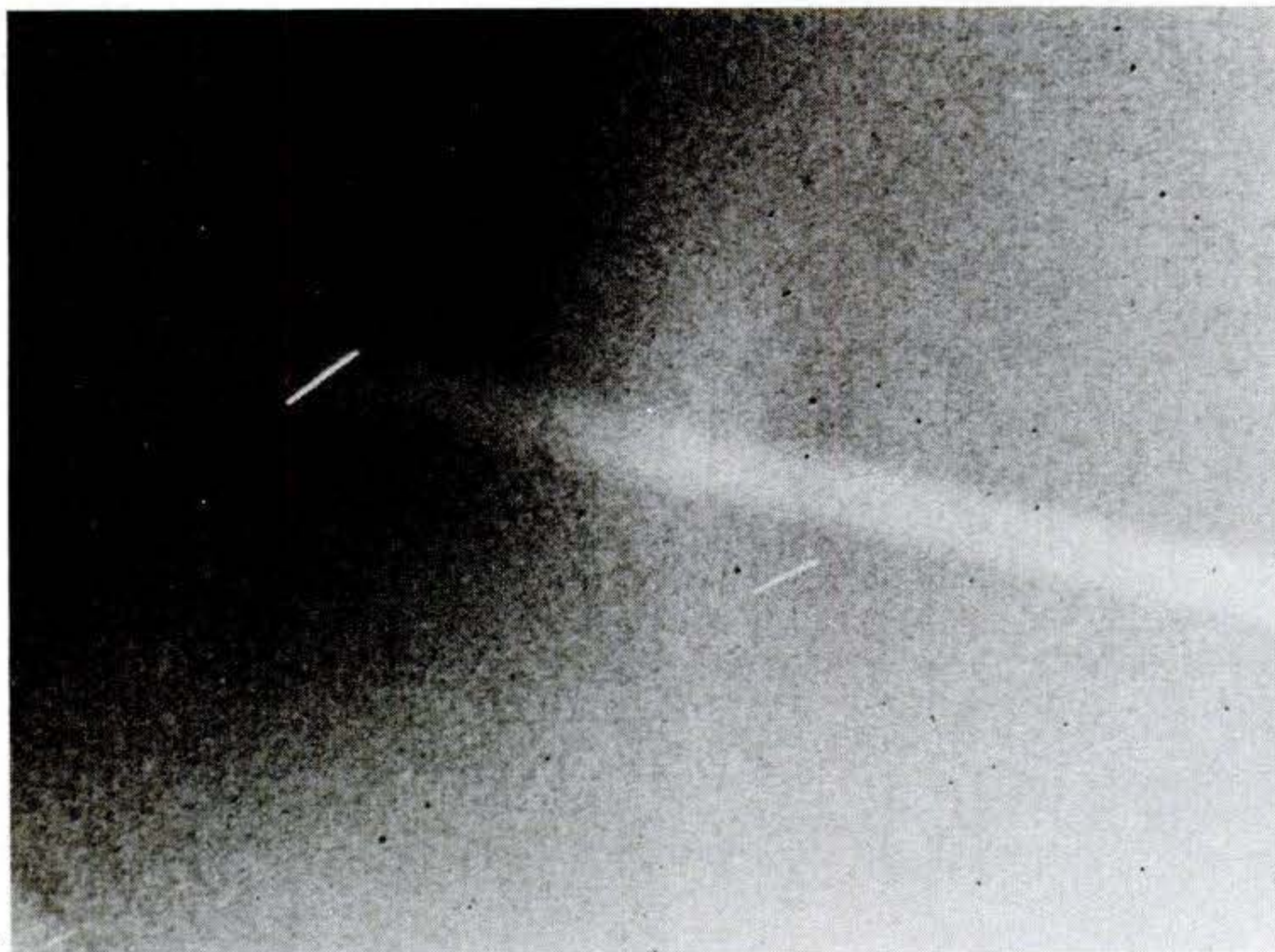

Voyager finds new moon

This photo may not look like much, but it's a sample of what makes planetologists preen. It was taken last July 8 by NASA's Voyager 2 spacecraft on its flight past Jupiter; subsequent computer enhancement reveals, in the faint white streak to the right, the presence of a new, previously unknown Jovian moon, to add to the 13 already tallied [PS, July '79]. Named 1979-J1, the moon orbits at the edge of Jupiter's ring, seen here as a broad, gray diagonal band across the picture. Both the track of the new moon and that of a star, seen as the white streak at left, result from relative motion during a long time exposure. NASA experts calculate that the moon orbits Jupiter some 57,000 kilometers (36,000 miles) from the planet's cloud tops. They estimate its diameter to be 30 to 40 kilometers (18 to 25 miles). Its orbital speed is apparently the fastest in the solar system—30 kilometers per second (67,000 mph), with each perambulation around Jupiter taking just seven hours, eight minutes.

Neutrons against cancer

An intrinsic part of nuclear-weapons technology is going to be modified to join the war against cancer. Devices known as neutron generators have long been used to produce an intense shower of neutrons to initiate an explosion. Now researchers at Sandia Laboratories, supported by an \$800,000 grant from the National Cancer

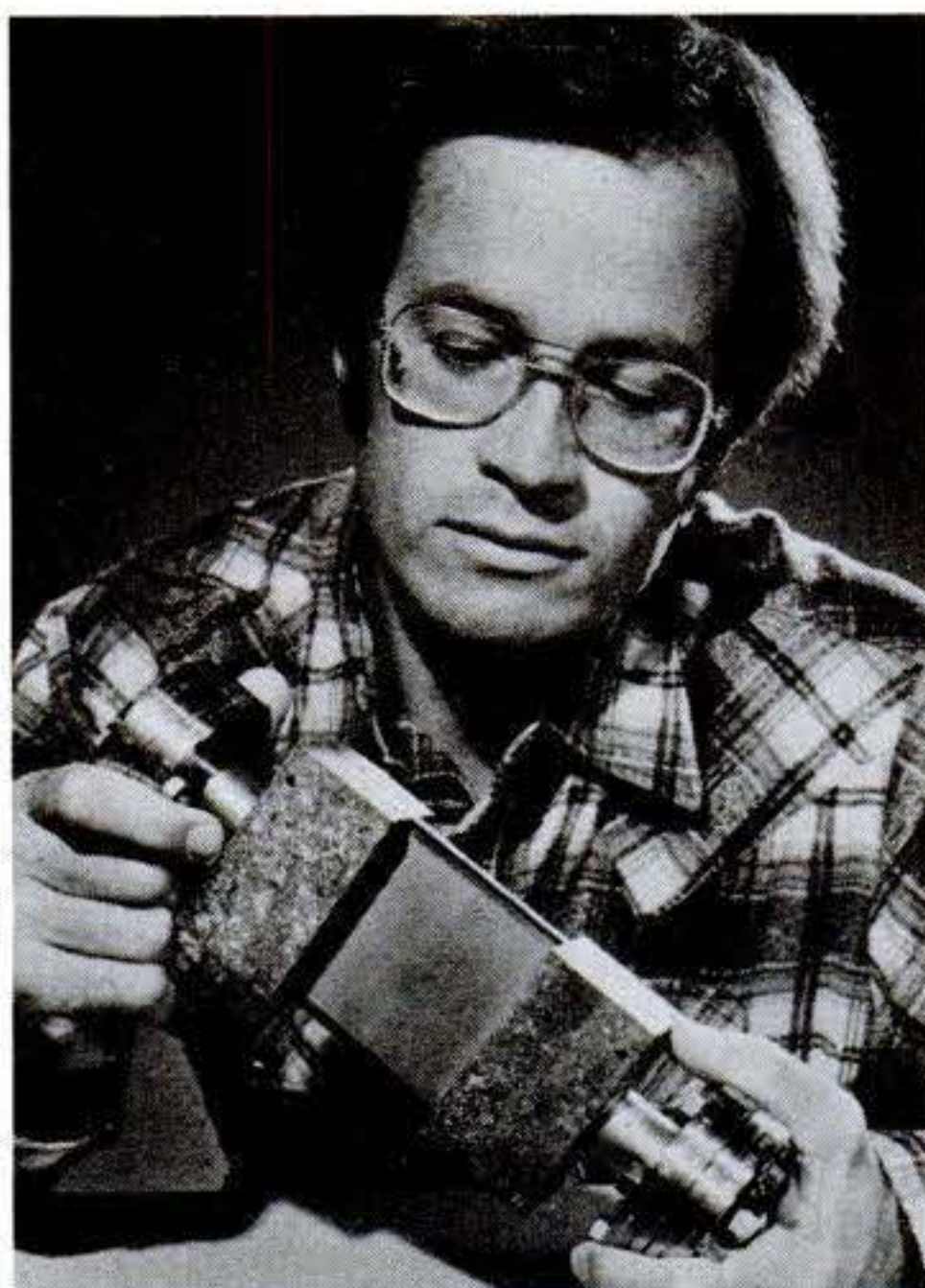

Institute, are developing a neutron generator for cancer therapy. Preliminary research shows that some cancers may respond better to continuous intense neutron beams than to X-ray or gamma-ray therapy. In the photo (above), Dr. D. F. Cowgill of Sandia holds a target he designed for the proposed neutron device. In use, it would be coated with a metal film containing deuterium and tritium, and bombarded with deuterium and tritium ions. The cost of a neutron machine

for clinical use would be about \$1 million to \$1.5 million—one-third to one-half the cost of the larger cyclotrons being proposed for cancer treatment.

Sunflower power

Sunflower oil might someday serve as a farm fuel in parts of the country where the plant is plentiful. (Last year, about 3.5 million acres of sunflowers were grown, mainly in Minnesota, North Dakota, and California.) In a Minnesota trial, an unmodified 25-hp, two-cycle diesel engine ran smoothly on the oil. There's a catch, though: The present price is \$2.50 per gallon.

Superconducting generator

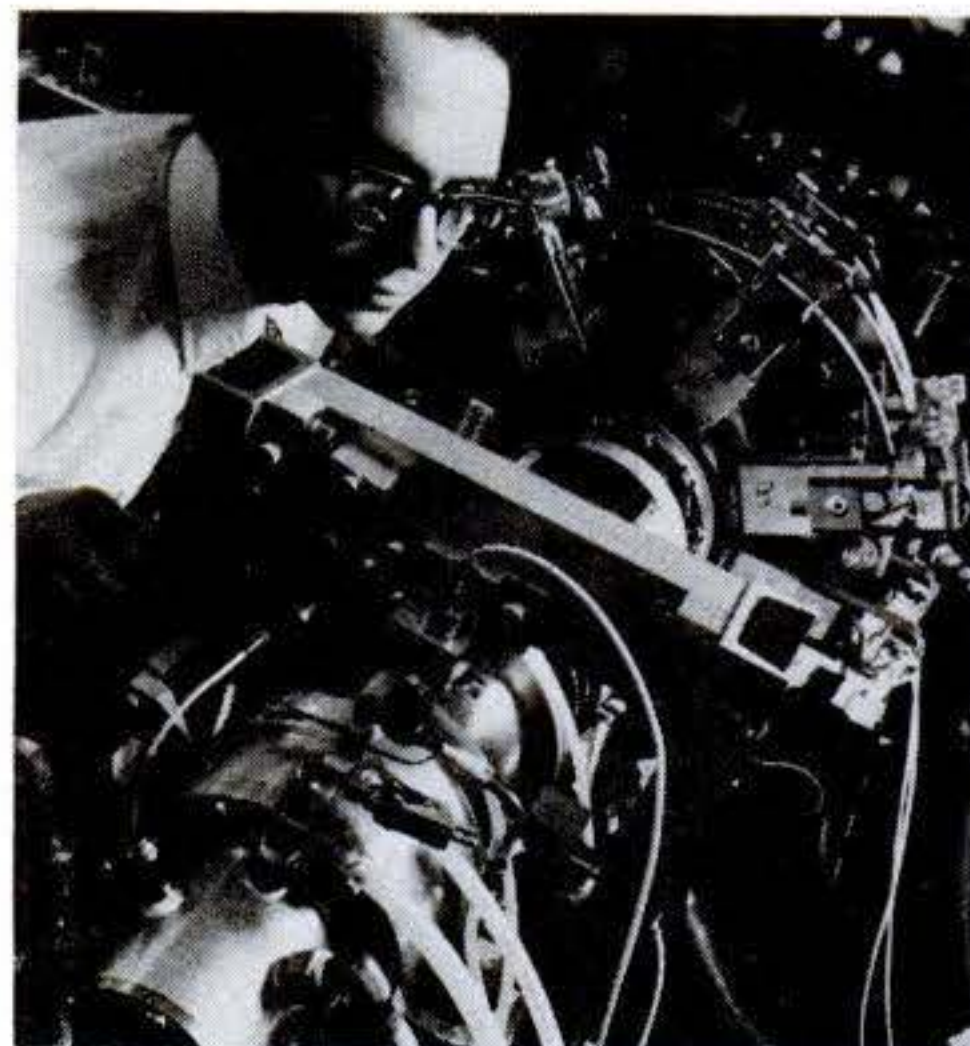

Tests by engineers at the General Electric Research and Development Center in Schenectady, N.Y., have confirmed that an experimental superconducting generator should indeed be able to provide as much electric power as a conventional generator twice its size and weight. The critical test was a severe trial of the generator's key component, a 13-foot-long, 1½-ton rotor. In the photo, Dr. Trifon E. Laskaris is inspecting the outer assembly of the rotor, which was spun at 3600 rpm while it was cooled by liquid helium to -452 degrees F. When it is finished in 1981, the GE generator will produce 18 million watts of electrical power, enough for a town of 20,000 persons.

Oldest human footprints?

In what has been called a "paleoarcheological hole in one," a team of researchers, in a routine geological exploration along the shore of Lake Turkana in northern Kenya, have uncovered seven footprints that may be the oldest trace of humanity on Earth. Dr. Anna K. Behrensmeyer, a paleoecologist who is co-leader of the Kenyan expedition, reports that the footprints are 1.5 million years old. That long ago, there were two known hominids, or manlike creatures: *Australopithecus* and *Homo erectus*, the direct ancestor of today's human beings. The likelihood from fossil evidence, says Dr. Behrensmeyer, is that the footprints were made by *Homo erectus*. The expedition was part of a large research project directed by Rich-

Continued

Treasure Detector

A new computerized metal detector that actually selects treasure from trash may uncover America's long lost relics and precious metals.



The new breakthrough in metal detectors makes finding treasure much easier.

There's a lot of treasure right under our feet. There's also a lot of garbage.

And the problem with most metal detectors is that they're dumb. They can't tell treasure from trash.

The new Techna metal detector is different. It has both a sensing system and a brain that can tell the difference between a foil gum wrapper and a coin—between a bottle cap and a diamond ring.

The new breakthrough was made possible by the use of a "discriminator IC"—a computer-type integrated circuit that can compare the ferrous and non-ferrous relationships that distinguish treasure from trash.

There are discriminator-type metal detectors now on the market, but they cost between \$170 and \$400. And no matter what price you pay, the detector is usually difficult to operate.

The new Techna Discriminator represents several breakthroughs. First, it is inexpensive—only \$69.95. Secondly, it uses a new (patent pending) phase compensation system of metal detection, whereas other discriminators use either the off-resonance or inverse discrimination principle.

This system utilizes a microprocessor circuit which replaces the conventional electronics, mode switch, and multiple tuners that added to the cost and weight of a discriminator unit.

Finally, the Discriminator is very easy to operate and understand. You simply set it to sense treasure, trash, or both and it automatically tunes itself and starts operating. Whenever you scan treasure, a loud speaker will emit a sound and you start digging.

DETECTORS ARE BIG BUSINESS

Metal detectors are big business. When we investigated the field, we discovered an entire new sport—treasure hunting. Treasure clubs exist and conduct contests. There's a national magazine and an association, and hundreds of thousands of units are in use every day.

Treasure hunting doesn't just mean looking for buried pirate chests. There's great interest now in discovering articles of historical significance such as old coins, military buttons, and old pistols.

Long ago when people distrusted banks, they buried their valuables somewhere on their property. If they died suddenly or became

senile, their treasures were lost forever. Many treasure hunters are now visiting ghost towns or going through older sections of cities looking for both historic and valuable articles.

WORLD WAR II STARTED IT

Metal detectors first saw extensive use during World War II. Back then, they were called mine detectors and were used to uncover enemy land mines. They were heavy, often weighing hundreds of pounds, and had to be carried on the backs of soldiers along with separate and heavy power supplies.

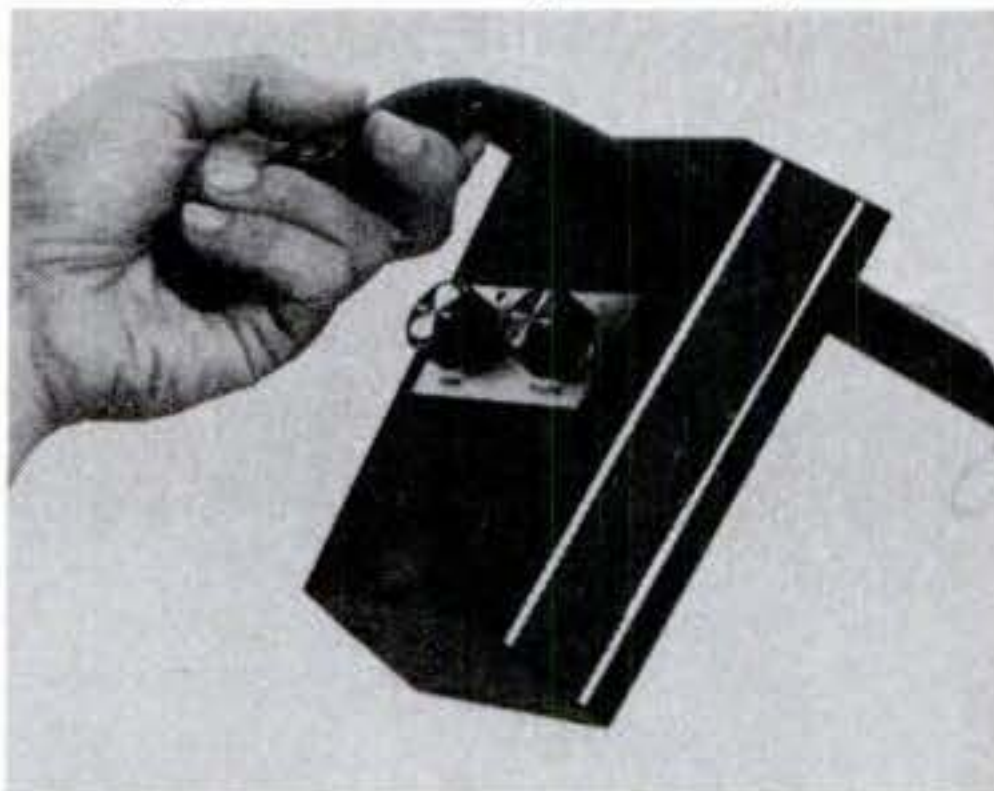

The Techna Discriminator is light and easy to operate with only two controls to adjust.

The new Techna Discriminator is light. It weighs only 2½ pounds and is powered by two readily-available 9-volt batteries. As you glide the sensing head over the ground, the unit remains silent until it uncovers a precious metal or whatever type metal you are searching for. An electronic sound is emitted. Then just dig in the area of the sound.

If you already own an expensive metal detector, you know that most of your "discoveries" turn out to be bottle caps or gum wrappers. With the Techna, you discover just what's worth digging up. While others are digging up bottle caps, you're covering more ground faster and are more likely to discover something worthwhile.

BREAKTHROUGH PRICE

The fully computerized Techna Discriminator is available from JS&A for only \$69.95 complete with batteries and all components. We suggest you order one just to try it out. Try it in your back yard. Take it to a sandy beach

where many coins and jewelry are lost. See how the system can tell the difference between treasure and trash, and then after you have discovered the fun of treasure hunting and how advanced this new product really is, decide whether or not you wish to keep it.

If you feel the Techna Discriminator does not meet all your expectations for any reason, we will gladly accept the return of your unit within our 30 day trial period and even refund your \$3.50 postage and handling. If you decide to keep your unit, you will own the world's most advanced metal detector. No competitive model even comes close.

Techna is America's largest manufacturer of metal detectors in the United States, and JS&A is America's largest single source of space-age products—further assurance that your modest investment is well protected.

Each Techna detector is backed by a solid one-year parts and labor limited warranty. We doubt if you'll ever have a problem with the unit because of its solid-state construction, but if service is ever indeed required, Techna's service-by-mail center will fix your unit and have it back to you quickly.

To order your Techna Discriminator detector, send your check for \$69.95 plus \$3.50 for postage and handling (Illinois residents please add 5% sales tax) to the address shown below. Credit card buyers may call our toll-free number below. We will promptly send you your Techna detector with batteries, 90-day limited warranty, and instructions.

Why not join the legion of treasure hunters worldwide with the world's most advanced space-age metal detector. Order the Techna Discriminator metal detector at no obligation, today.

JS&A NATIONAL SALES GROUP

Dept. PS One JS&A Plaza
Northbrook, Ill. 60062 (312) 564-7000
Call TOLL-FREE 800 323-6400
In Illinois Call (312) 564-7000

© JS&A Group, Inc., 1978

The Andy Costellos are saving \$12 to \$15 a month on their electric bill...



that's at least \$144 a year!
How are they doing it?

With the Efficiency II™ heat pump water heater. The Efficiency II attaches to the existing electric water heater and draws heat from the surrounding air to heat the water, providing the same amount of hot water while using half as much electricity.

The Costellos are pleased with the results:

"We're satisfied with the Efficiency II. It's been saving us about 12 to 15 kilowatt hours a day. That translates into \$12 to \$15 a month".

Find out more about the Efficiency II and how it can save you money. Call or write us today.

Mail to: E-Tech, Dept. PS2
3570 American Dr.
Atlanta, GA 30341
(404) 458-6644

Name _____
Address _____
City _____
State _____ Zip _____
Telephone: Home _____
Work _____

Our home is heated by:
 electricity oil gas
Our electric water heater is located in the _____

Science newsfront

[Continued]

ard E. Leakey of the National Museums of Kenya, and was supported by the National Science Foundation and the National Geographic Society.

Ozone debate revisited

The National Research Council, which warned in 1976 that continued use of halocarbons would deplete the Earth's protective shield of ozone by 7.5 percent [PS, June '77] has now upped that number to 16.5 percent—half to be reached in the next 30 years. The Council report uses improved techniques for predicting chemical reactions and circulation in the atmosphere. The ozone layer protects all life from the harmful effects of intense ultraviolet radiation. It can be disrupted by halocarbons—used in aerosol cans, refrigerators, air conditioners, plastic foams, solvents, and elsewhere. Despite a U.S. ban on the chemicals that are found in spray cans, worldwide use of halocarbons is increasing.

Cleaning up with hyacinths

Most people regard the water hyacinth as nothing more than a nuisance, because its unrestricted proliferation has clogged certain inland waterways. Not so the marine scientists at the Lockheed Center for Marine Research, in Carlsbad, Calif. This floating plant (a bunch is being held by Karen Green in the photo) has the unusual property of being able to accumulate in its own tissues a variety of toxic substances, including trace metals, that are found in

sewage and waste water. Moreover, as energy experts have previously pointed out, the fast-growing plant is eminently suitable for biomass conversion into fuel. Combine the two attributes and the possibilities are intriguing. Says Lockheed's Dennis Brining, "Technology exists to use water hyacinths as just one part of a total closed-loop system. It would not only clean waste water, but in the process could be used to produce methane gas in sufficient quantity to power the entire system, and, as a byproduct, be used for fertilizer and animal feed."



Solar air sampler

The newest member of a network of more than 100 air-quality samplers in the state of New Jersey is unique: It's this country's

first solar-electric-powered air-monitoring station. The new sampler, located in Liberty State Park, relies on a 360-watt array of 20 photovoltaic modules, with a total of 860 individual silicon solar cells. The

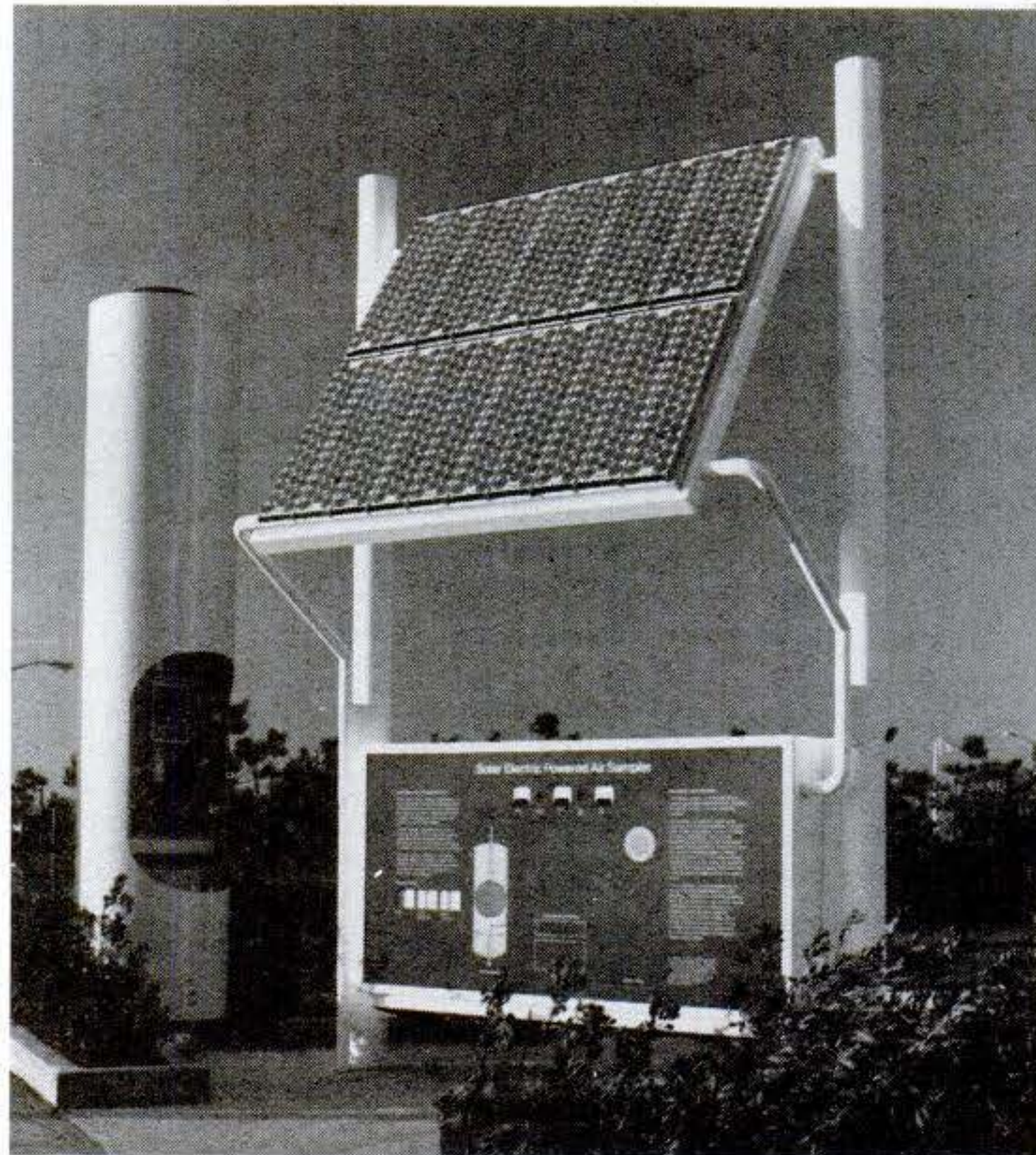

96-square-foot array is mounted atop a 17-foot-tall tubular aluminum frame. The new system monitors the air every sixth day for a period of 24 hours to determine whether it meets both state and federal standards. Air is forced through a glass-fiber filter that traps particulate matter, and the filters are removed each week. Designed by NASA's Lewis Research Center, the \$93,000 installation was funded jointly by the Department of Energy and the New Jersey Department of Environmental Protection. [PS]

If you're not home to protect your family, leave it to *First Alert*.[®]

Introducing the new *First Alert* Family Protection System.[™] Now, one system can warn you of many household dangers — the new First Alert Family Protection System. Because of its advanced wireless technology this home burglar alarm is easy to afford and easy to install.

The system comes with a receiving console and a battery operated door intrusion transmitter. Additional door and window transmitters can be added to custom design the system for your home. And,

a remote siren is available to alert neighbors and scare off intruders.

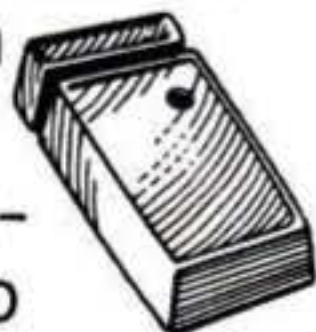

The receiving console can also monitor compatible First Alert smoke detectors which can warn you of fires that start in remote areas of your home.

And it can monitor First Alert gas detectors for warning of leaking propane or natural gas.

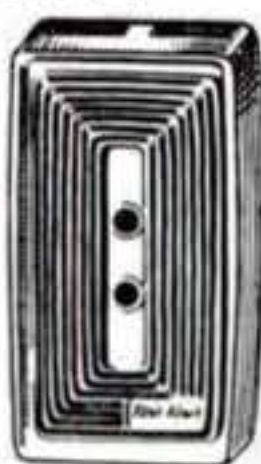

Finally, a hand held personal emergency transmitter can activate the remote siren outside your home to scare off would-be intruders, alert neighbors and summon help in the event of a medical emergency.

Home or away, protect your family with the new First Alert Family Protection System.

“It's all the protection you can ask for.”

William Conrad

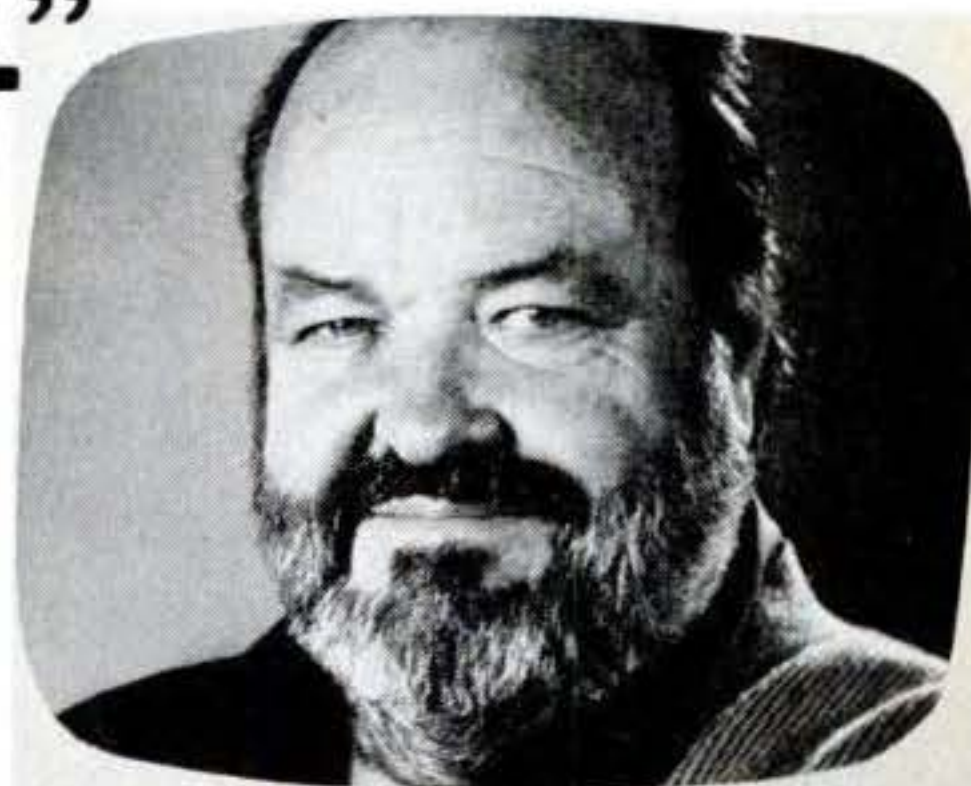

First Alert
by PITWAY

the professionals in home and family protection.

Order Your Thermograte® Home Heating Appliance Now . . . Pay For It Later!

Due to the high demand resulting in shortage of our quality woodburning units, and the cost, you may not have purchased the Thermograte® Fireplace Furnace or Fireplace/Stove you need. Order now and have 12 months to pay!

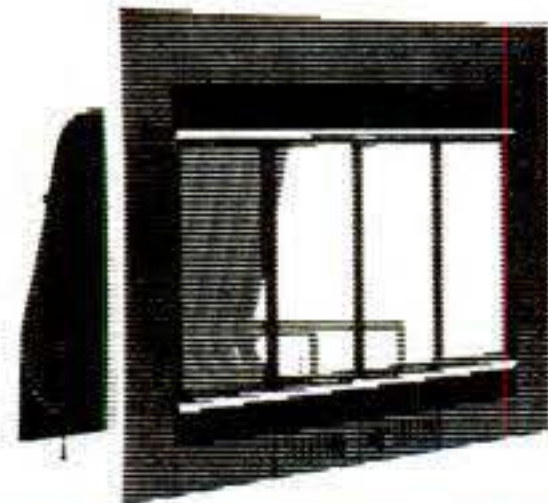

No interest or carrying charge. 6-month trial. Lifetime warranty on stainless steel tubes against burnout.

SATISFACTION GUARANTEED!

IT WORKS!

Cool air in tubes is heated, expands and rises. Heated air flows into your home . . . naturally!



For FREE information, write:
Thermograte Ent., Inc. Dept. 860-003
P.O. Box 43021 St. Paul, MN 55164
Or CALL TOLL FREE: 1-800-328-0882

© 1980 TEI ST. PAUL, MN 55113. ALL RIGHTS RESERVED.

Performance that makes you smile

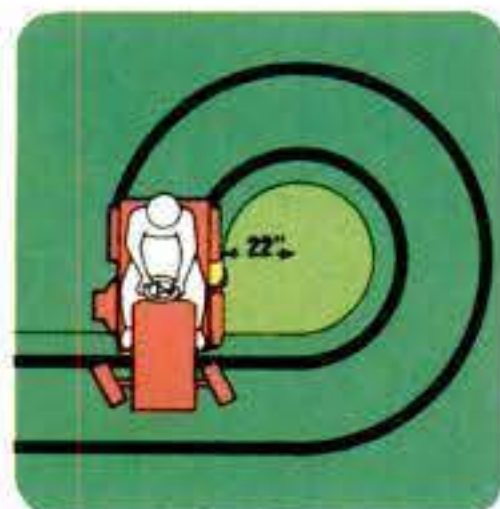
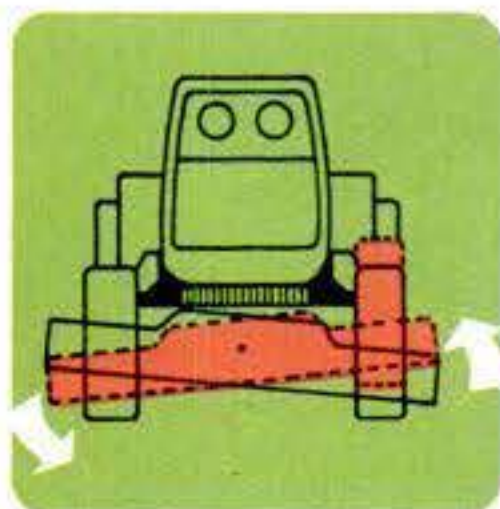
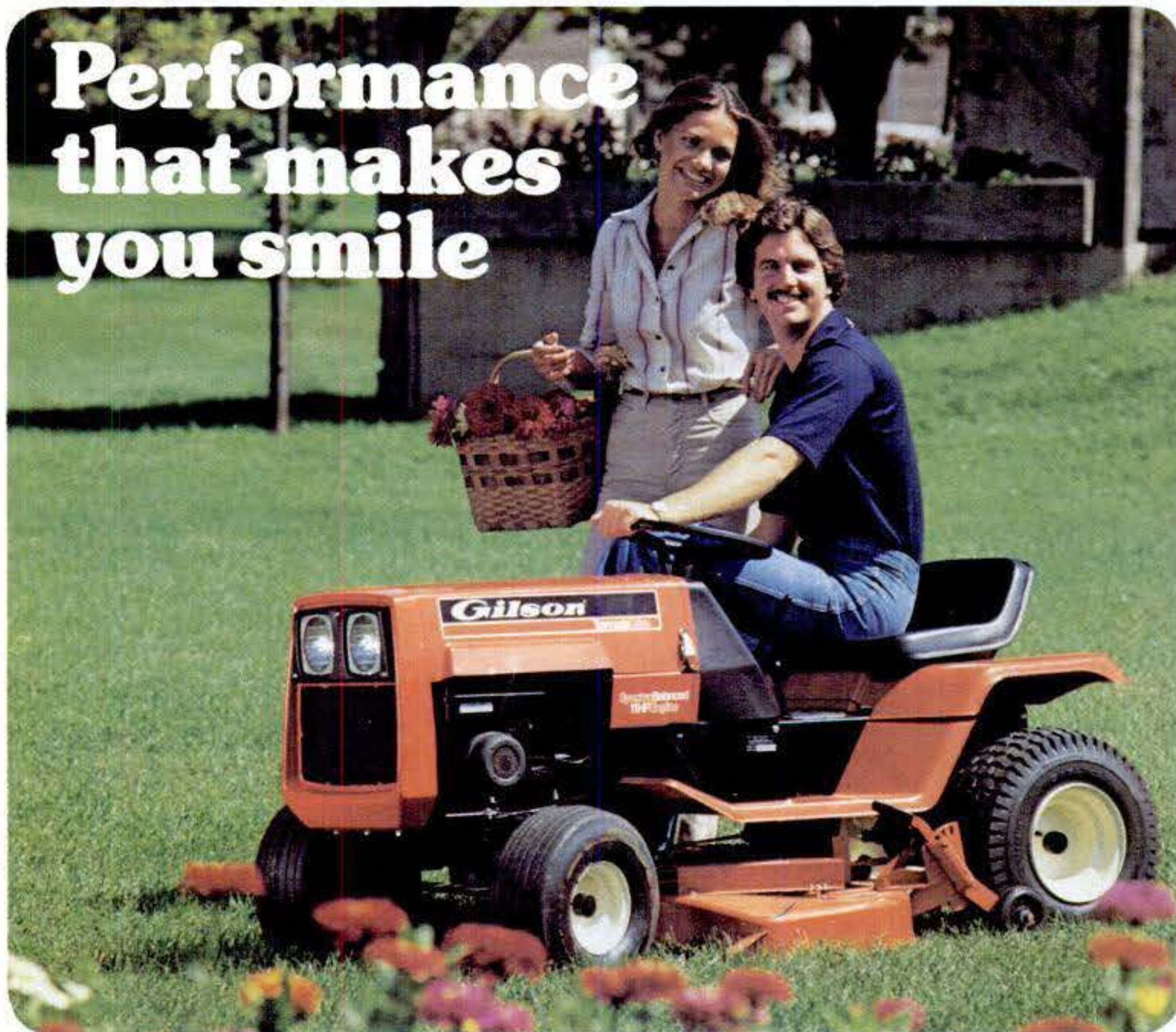

Any mower cuts grass. But Gilson innovations help you do it faster and better. Choose an economical 8 hp, dependable 11 hp gear drive or an easy operating 11 hp hydrostatic. **Unique mower flotation system** rises and tilts with lawn contours. Cuts evenly. **Short, 22-inch turning radius** lets you trim close around most trees and shrubs with one pass. **Specially designed booster fans** on the new 38-inch rear discharge mower spread clippings evenly over a wide area, plus you can mow in any direction or trim close on either side. **New 5-bushel grass catcher** for use with side discharge mowers gives you an extra-clean lawn, conveniently. See your Gilson dealer or write for information.

Gilson®

Gilson Brothers Company
Box 152-S, Plymouth, Wisconsin 53073

Pumping uranium from underground wells

Mobil Oil's new field in Hebbronville, Tex., produces not oil, but uranium.

"It's a new technique called in-situ leaching," says Mobil's Charles Spruell. "The technology is similar to water-flooding, the method used to recover oil by pumping in water to drive out the trapped oil (see PS, July '79).

"We pump a nontoxic solution in through four injection wells to dissolve the uranium (see diagram). It's pumped out the center well at a slightly higher rate. This creates a pressure sink, forcing the dissolved uranium out the center well."

The solution then goes to a recovery plant, where the uranium is processed into "yellowcake," the raw stuff used to produce fuel rods for nuclear reactors.

Why is leaching better? "Until now, uranium mining has been much more cumbersome," explains Spruell. "It's meant digging a large pit or excavating underground. In the leaching process, only the wells come into contact with the ore deposit, and the environment is relatively undisturbed."

Another advantage: Conventional techniques produce 1000 to 2000 pounds of waste per pound of yellowcake. Leaching produces only one pound of waste per yellowcake pound.

The Hebbronville plant, the first large-scale in-situ operation, produces 650,000 pounds of yellowcake per year.

"That's the energy equivalent of 60,000 barrels of oil per day," says Spruell, "or enough energy to supply one year's electricity for a city the size of San Antonio."—*Harriet Brown*

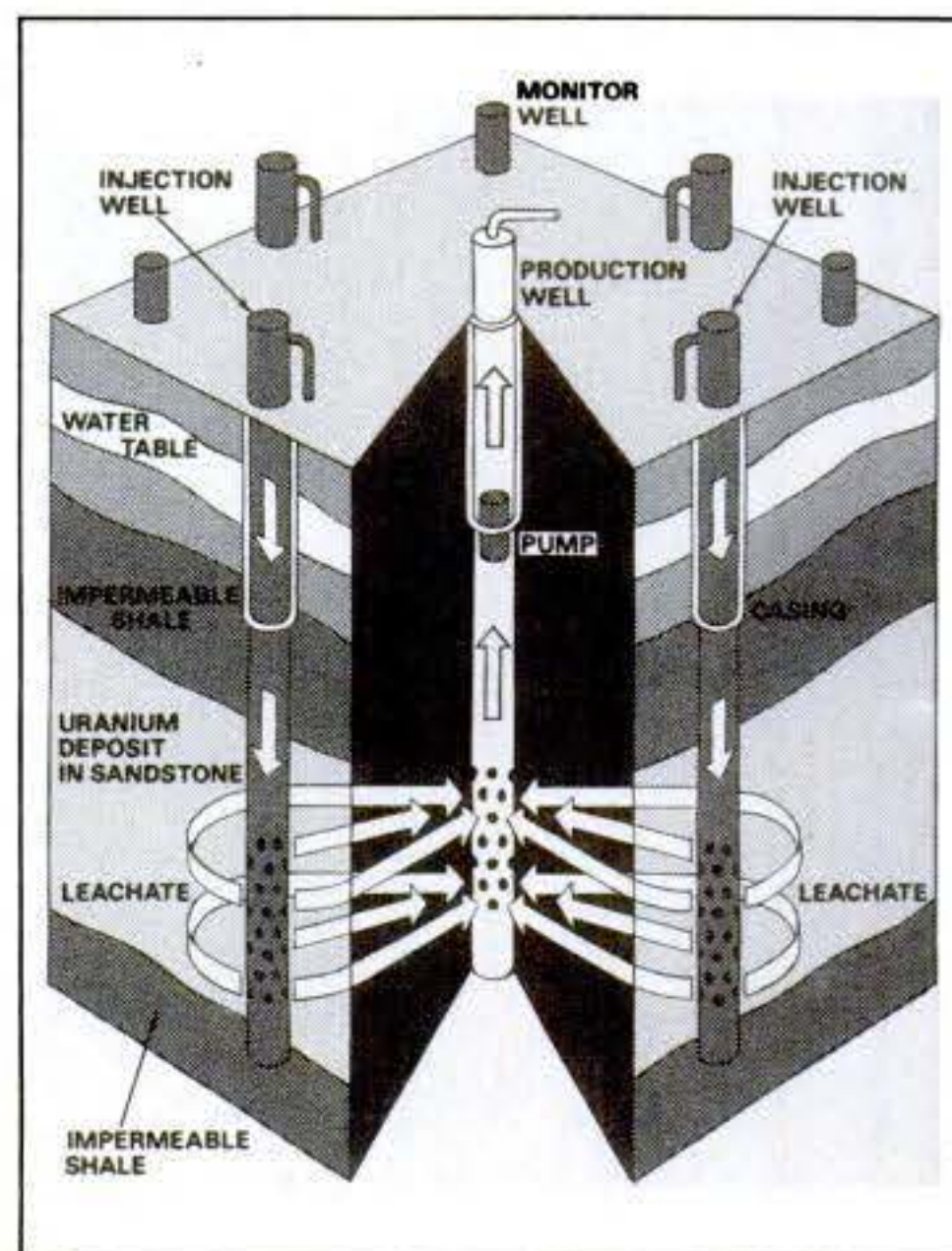

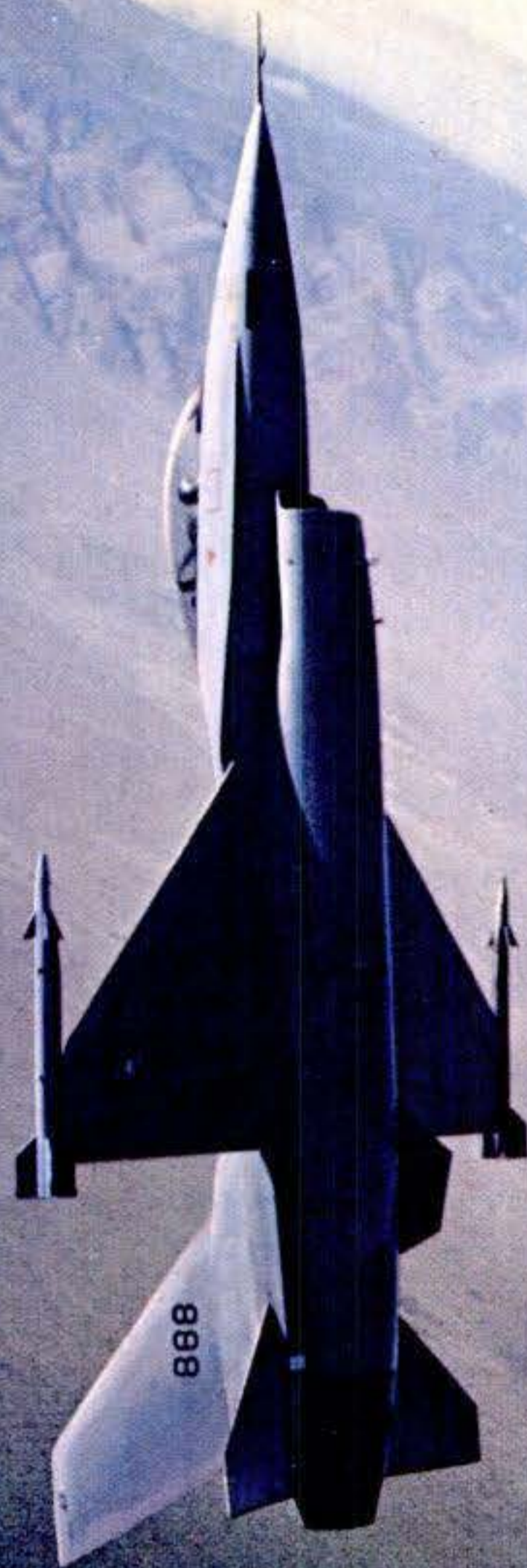

MOVE UP IN THE WORLD!

Everybody knows you've got to have experience. So think about it this way: Experience will get you off the ground. AIR FORCE EXPERIENCE will take you as far as you want to go.

See your Air Force Recruiter — for yourself and your country. Mail in the attached card. Or call toll free 800-523-5000 (in PA: 800-362-5696).

A GREAT WAY OF LIFE
AIR FORCE

CALCU-LETTER

By DARRELL HUFF News of pocket calculators—and how to have fun with them

Limits of accuracy

A distressed reader, Herb Lacey of Cary, N.C., reports that his new scientific calculator thinks the 24th power of two is 16,777,200. And so do all the rest of the units of this model his dealer stocks.

He was immediately suspicious of the answer, he points out, since there's no way a whole-number power of two can end in zero. Program error on the chip is his diagnosis.

It's that valuable y^x key (roots and powers) that gives the erroneous result, of course. To the limit of its display, any calculator will give powers accurately when you go the route of successive multiplication. It's the special preprogrammed keys you have to watch out for.

With all but the simplest calculators, there are alternate ways of doing many common problems. Comparing answers obtained in different ways will often point up errors.

When I follow normal procedures, my HP-19C tells me the 24th power of two is 16,777,216. My TI-59 agrees. Both give the same correct result when I use either common or natural logs.

But my old Rockwell 202, although responding correctly if I brute it out with two dozen pushes of times and equals, slips up with 130 as the final three digits when I use the normal y^x key. It confirms this error with both common and natural logs.

Cussed ladders

The January "Calcu-letter" introduced an ancient, and tough, ladder puzzle with a comparatively mild warm-up. You were told of two ladders leaning opposite ways between two buildings, one touching

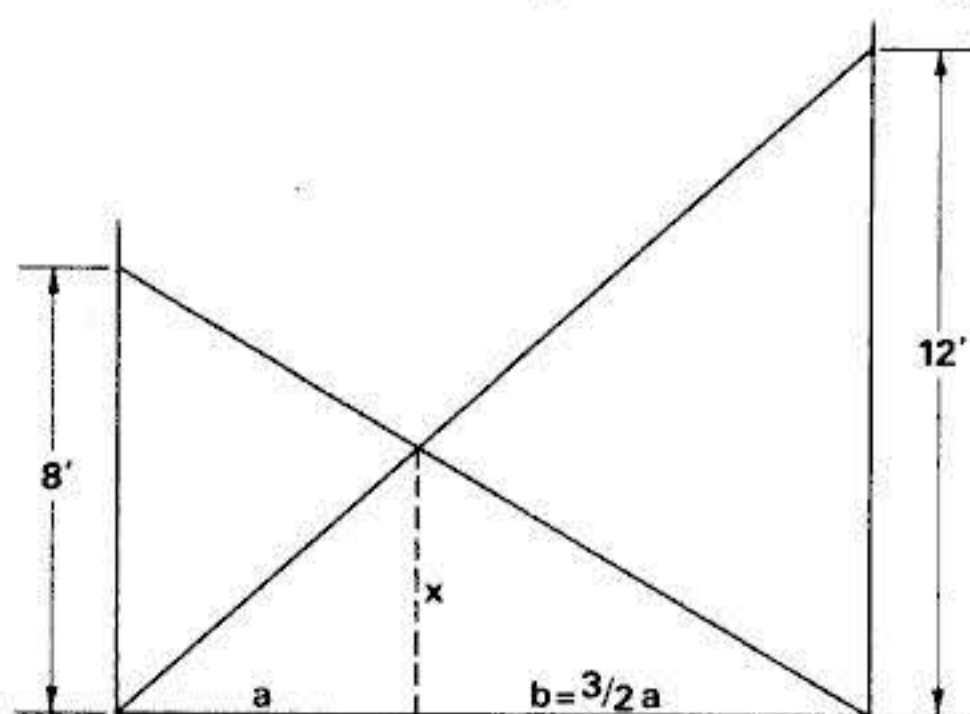

eight feet above the ground, the other 12. At what height above the ground would they cross?

The problem could have been solved using geometry, algebra, trigonometry, analytic geometry—or by selecting an arbitrary value for the distance between the buildings, since the height must be the

same no matter what distance is used. My tiny Sinclair Cambridge gives an even wilder result when I use the only alternative it offers to the long route. Employing natural log and antilog keys, I find the answer is 16,786,630, which is off-base in the fourth digit. That's a useful warning. Further checking against other calculators uncovers similar discrepancies, usually the inevitable result of rounding. Every machine has its limitations, but you should be aware of them.

Just for fun

Ask a friend to select any number consisting of the same four digits repeated—7777, for example—enter them into a calculator, and then divide by the sum of the four digits. Blindfolded or standing across the room, you pretend to concentrate very hard and then call out the answer.

The secret, of course, is that the answer will always be the same. With a little simple algebra you can prove why.

This trick comes from a little book put together by one of our fellow calculator nuts, Al Hauser. Along with a dozen or so tricks of this sort, it offers a collection of stories based on the words calculator displays make when inverted and read with a little imagination. "Nothing educational in the entire book," is the author's slogan. *Pre-calculated Fun* is \$2.95 plus 55 cents for mailing from: Al Hauser, 1324 West Berridge Lane, Phoenix, Ariz. 85013.

Maybe the simplest way is to label the distance on the ground from each building to line x as a and b , which allows you to set up two simple ratios based on similar triangles:

$$\frac{12}{a+b} = \frac{x}{a} \quad \text{and} \quad \frac{8}{a+b} = \frac{x}{b}$$

Multiplying both equations through and substituting for the common term yields what may have been intuitively obvious: $b = \frac{3}{2}a$. Now you can rewrite the above equations using $\frac{3}{2}a$ in place of b and $\frac{5}{2}a$ in place of $a+b$. Solving both equations for x (the a 's cancel) gives the height above the ground at which the ladders intersect: 4.8 feet.

Now you are ready to try the second variation of the cussed ladders. This time, ladder lengths are given as 40 and 30 feet, and they cross at a point 10 feet from the ground. How far apart are the buildings against which the ladders are leaning?

Because in this puzzle you have three dimensions given instead of two, it may at first glance look to be the easier problem. It is not. This one will require that you use your calculator—as well as your head.

More books for calc buffs

Dealing with PS calculator fans often leads me into math beyond my depth. If you, too, sometimes run short in that department, you might like to know about a fat and thorough reference work I've been consulting with some frequency. It's the *VNR Concise Encyclopedia of Mathematics*, translated and printed in West Germany but published in English by Van Nostrand Reinhold Co., New York. A good bookstore should have it. With its 760 pages and a picture section, it's a lot of book for \$14.95.

A book that may interest you if you have anything to do with printing or publishing is *Computer Age Copyfitting*. Quite the opposite of the book just mentioned, this one is a thin, simple, highly specialized paperback. It tells precisely how to fit copy to space, doing the arithmetic by hand calculator. The author is Leslie Rasberry and the book, along with the pad of charts to use with it, can be had from Art Direction Book Co., 19 W. 44th St., New York, N.Y. 10036. Price: \$8.95.

Jack Buchanek and Ed Bergin, a couple of policy analysts who happen to be in love with their sailing yachts, have put it all together in a fat but simply written book. The title tells it all: *Piloting/Navigation with the Pocket Calculator*. It's available from Tab Books, Blue Ridge Summit, Pa. 17214; \$12.95 hardbound or \$8.95 in paperback.

The same publisher offers Jack Gilbert's *Advanced Applications for Pocket Calculators*, \$8.95 hardbound, \$5.95 paper. Though the book is four years old and inevitably out of date in places, much of it is as useful as ever and hard to duplicate anywhere else. Especially handy are chapters on doing quite sophisticated math with simple models that don't have keys for roots, logs, trig, and the like.

If you'd like to know more about how computers and calculators work, look into the paperback *Understanding Digital Electronics*, by Gene McWhorter. By mail, it's \$4.95, plus \$1 for shipping, from Texas Instruments, Box 53, Lubbock, Tex. 75222. Also from this source, at the same price, is *Understanding Solid-State Electronics*, developed by TI's Learning Center, now in a new edition.

Trig trick

Find the angle of which the number of degrees is equal to the cosine. Also find the angle that is equal to its arc tangent. Then, after you've discovered the routine, what is the least number of keystrokes with which you can get and confirm each answer?

This exercise, proposed by Tracy L. Snyder after he came across it in *The Bent*, an engineering publication, demonstrates the ability of scientific calculators to tackle problems that could not be solved in any other way. How many keystrokes? I found that I needed anywhere from four to 15 strokes, depending on whether I jumped in blindly or used my head, and which of several breeds of calculator I was using. The answers to eight places: 0.99984774 degrees and 89.358839 degrees. E

MORE COLOR. MORE SOUND. MORE GRAPHICS CAPABILITIES.

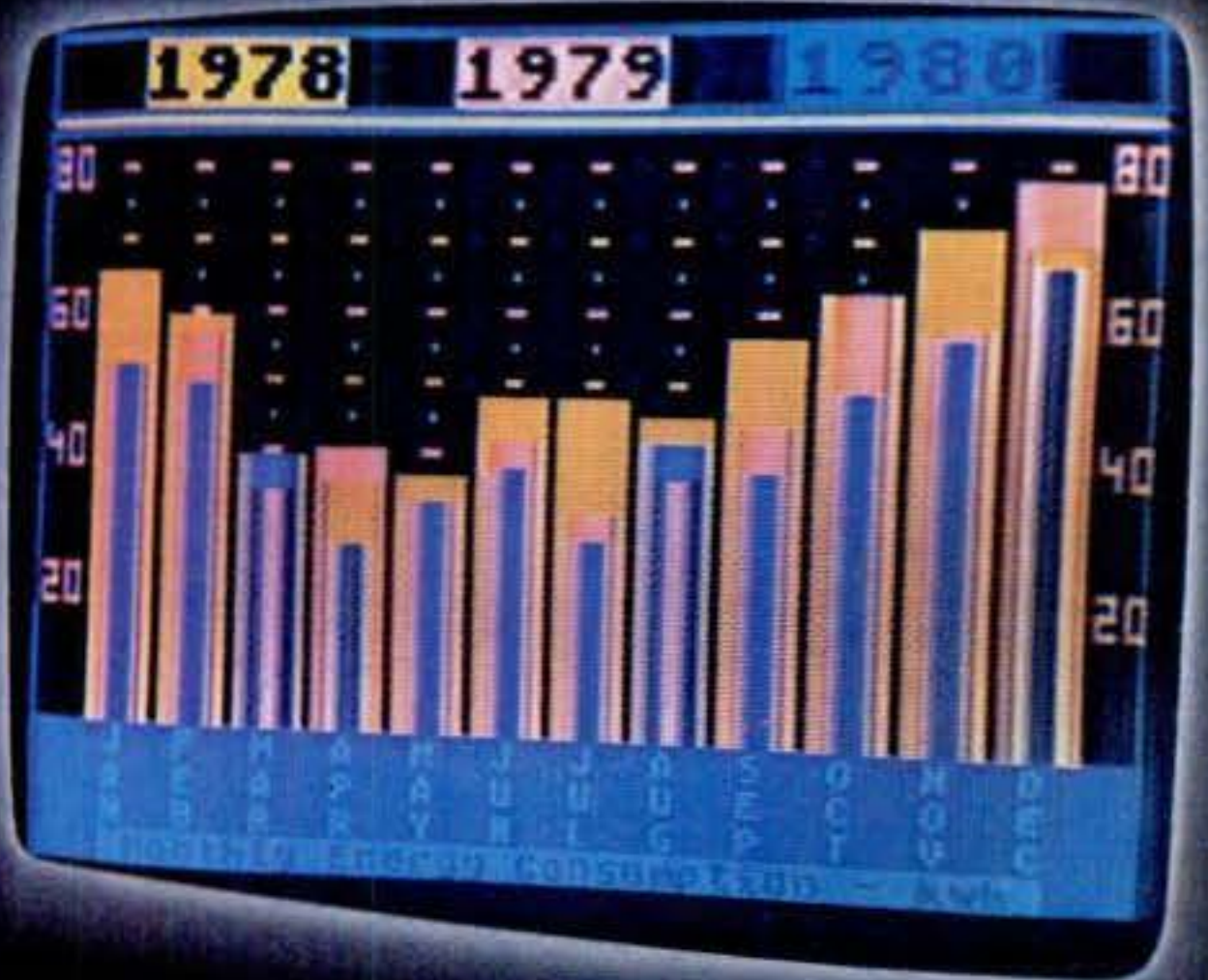
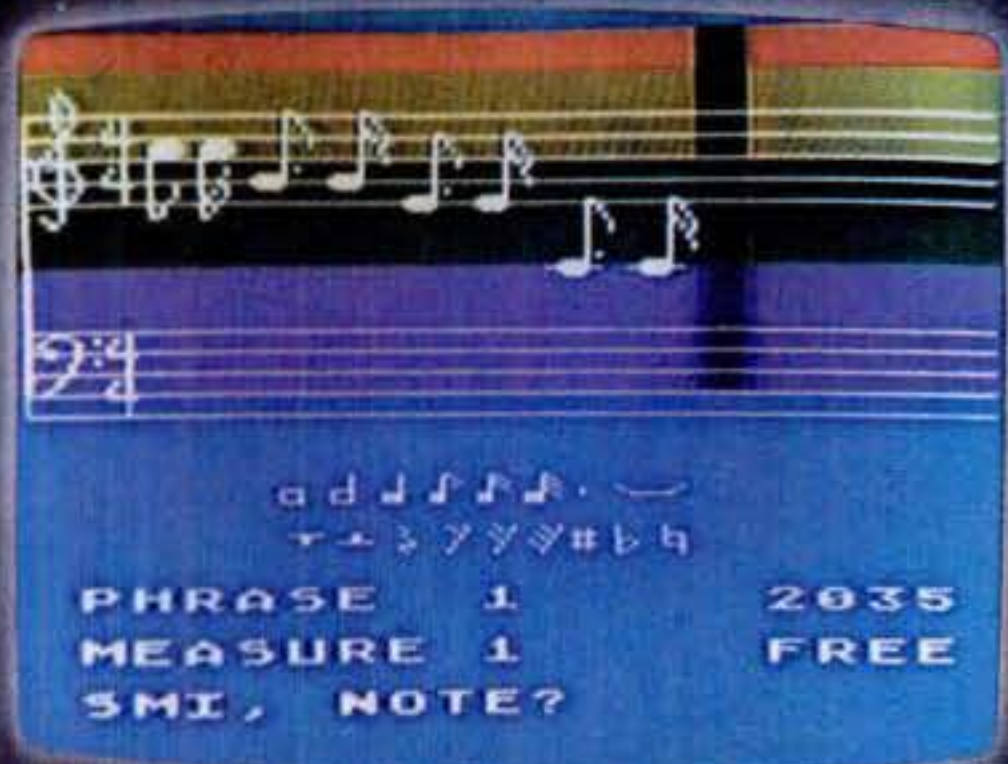

ATARI 400



ATARI 800

Compare the built-in features of leading microcomputers with the Atari personal computers. And go ahead, compare apples and oranges. Their most expensive against our least expensive: the ATARI® 400™.

Start with graphics capabilities. The ATARI 400 offers 128 color variations. 16 colors in 8 luminance levels. Plus 29 keystroke graphics symbols and 8 graphics modes. All controlled from a full 57 key ASCII keyboard. With upper and lower case. And the system is FCC approved with a built-in RF modulator. That's just for openers.

Now, compare sound capabilities. Four separate sound channels and a

built-in speaker. With the optional audio/digital recorder, you can add Atari's unique Talk & Teach™ Educational System cassettes.

Here's the clincher: Solid state (ROM) software. For home management, business and entertainment. Or just plug in an Atari 10K BASIC or Assembler language cartridge and the full power of the computer is in your hands.

Memory? 8K expandable to 16K. And that's just for the ATARI 400 at a suggested retail of only \$549.99.

The ATARI® 800™ gives you all that and much more.

User-installable memory to 48K. A full-stroke keyboard.

With a high-speed serial I/O port that allows you to add a whole family of smart peripherals. Including up to four individually accessible disk drives. And a high speed dot-matrix impact printer. And, the Atari Program Recorder is included with the 800 system. Suggested retail price for the ATARI 800 (including recorder) is \$999.99.

Make your own comparison wherever personal computers are sold.

Or, send for a free chart that compares the built-in features of the ATARI 400 and 800 to other leading personal computers.



PERSONAL COMPUTER SYSTEMS

1265 Borregas Ave. Dept. C, Sunnyvale, California 94086. Call toll-free 800-538-8547 (in Calif. 800-672-1404) for the name of your nearest Atari retailer.



Travellin' Fridges

FROM ONLY \$129.

Space age breakthrough creates a new line of Koolatron electronic portable refrigerators and food warmers.

You've nicely gotten away on your long awaited vacation, camping trip or long weekend with the family. You're comfortably cruising in your car, van or rec. vehicle along a busy interstate with few rest stops or restaurants. You guessed it... the kids want to stop for a snack. But your Koolatron P34 or P34A is full of sandwiches, cold pop, fried chicken... home made, fresh and cold. The family helps themselves and you've saved valuable vacation time and another expensive restaurant bill.

You're a commuter, a salesman or a trucker and you spend many hours in your vehicle daily. You've often longed for a fresh snack or cold beverage as the miles tick away. Now with your amazing Koolatron P10 plugged in beside you, you open the lid and instantly fresh food and drinks are at your fingertips. You're refreshed... you've saved an unnecessary stop, time and money.

AFFORDABLE CONVENIENCE

Home refrigeration has come a long way since the days of the ice box and the block of ice. But most of us resign ourselves to doing without the same convenience once we leave our homes. Or, we revert back to the cooler and ice routine of days gone by, simply because there's never been any dependable and inexpensive alternative. But now, for the price of a good cooler and one or two seasons of buying ice, (or about 10 family restaurant meals), all the marvels of home refrigeration are available electronically. And the sloppy

ice cooler with its soggy and spoiled food can become a stone-age memory for you. An amazing space-age miracle... the thermo-electric solid state module... makes this portable refrigeration revolution possible.

AEROSPACE MODULES

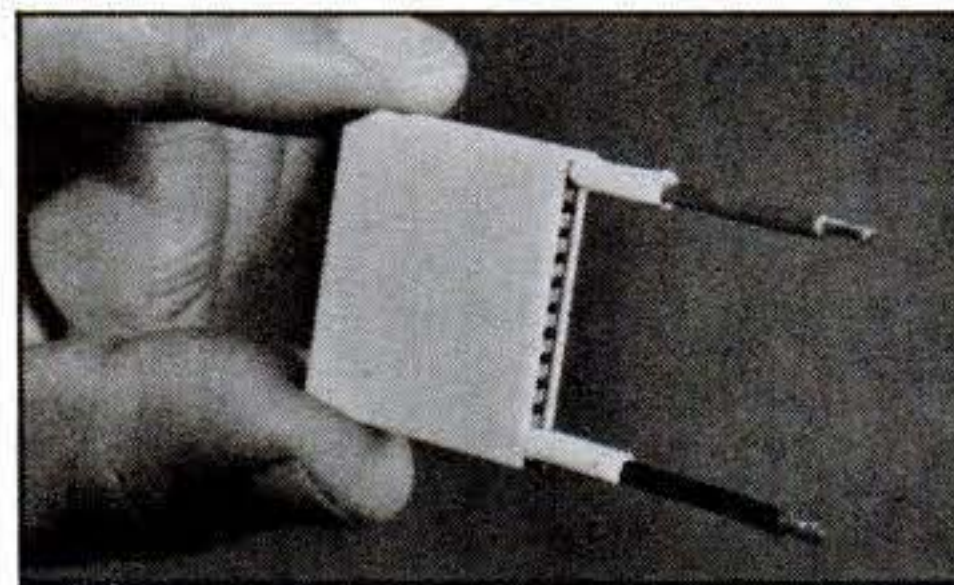

Two of these miniaturized thermoelectric modules replace all the bulky complex piping coils, compressors and motors in conventional portable refrigerators.

Utilized by NASA scientists, as the only refrigeration system for rockets and satellites, thermo-electric cooling has been in use for almost a quarter century. These expensive modules were selected by NASA for some basic reasons... they're small (about the size of your watch)... they're light weight (2 of them weigh less than a package of cigarettes)... they're totally reliable (these modules are completely solid state and have no moving parts)... they require little power (2 modules use the same power as one of your car's tail-lights)... they're completely insensitive to

tilting, bumping, vibration, (which causes failures to conventional compressors, motors and piping)... they're powerful (2 modules have the same cooling power as a 10 lb. block of ice)... and they never wear out or break down. And for portable refrigeration where you require 12 volt DC. power, thermo-electric modules are the most efficient. These amazing heat pumps have not only gone to the moon, but have provided the breakthrough for Koolatron's truly reliable, lightweight portable refrigerators.

THOUSANDS IN USE

Koolatron Industries Limited now has tens of thousands of these electronic fridges in use worldwide using these same powerful solid state modules. The reliability, performance and convenience of electronic refrigeration has now been dramatically tested and proven in all kinds of temperatures, conditions and environments from Australia to Alaska. Built to take it, two of these electronic modules are encased in tough, plastic insulated chests that are designed to be rugged and trouble-free. Non-rusting hinges and latches prevent corrosion in salt water environments. And with only one moving part (a small 12 volt fan) Koolatron portables seldom see a service depot. Koolatron's combination of space-age heat pumps and quality engineering have now led to a whole family of electronic portable refrigerators and food warmers that eliminate costly ice and provide "home refrigeration" convenience at sane and sensible prices.

**MODEL P10 -
THE PERFECT CAR FRIDGE
& FOOD WARMER**

\$129.00
(in Canada
\$139.00)



Holds approx. 17, 12oz. pop cans - refrigerates in air temps. up to 95°F. Also keeps hot foods hot (150°F.) at the flick of a switch. Deep rich blue Polypro plastic case. Ext. 16" L x 11" H x 11 1/2" W. Int. 11 1/2" L x 8" H x 8" W. with 10 litre capacity (0.4 cu. ft.) weighs 10 lbs. empty. Operates from supplied 12 volt power cord in vehicles or with optional 12VDC/110VAC power adaptor.

Koolatron's P10 not only makes a great car fridge but at a flick of a switch lets you bring home your favourite fast foods "piping hot". Comes with a 9 ft. power cord that just plugs into your cigarette lighter. Amazingly easy to operate ... one switch selects hot or cold. A second switch allows you to refrigerate normally or select maximum cold. With your engine off, you can operate for up to 6 hours and still start your engine. "A low battery" indicator warns you when it's time to recharge. With the power off, your P10 keeps everything hot or cold for many hours in its well insulated case.

As a travel fridge the P10 keeps your favourite foods and beverages fresh and cold wherever you go. If you're a salesman, your food samples will arrive perfectly hot or cold every time. If you carry insulin, medical samples, dietetic foods, your P10 will never leave your side. Great for private planes.

Photographers will find it invaluable for keeping expensive films from going bad. And mothers ... now you can refrigerate baby's formula in your car then heat it with the flick of a switch or keep it cold. Powerboaters, just plug it into your boat's cigarette lighter, and keep a day's food and drink ice cold without running into shore for ice. You campers, hunters and fishermen will find endless uses for transporting provisions and bait ... then take home your catches and game without spoiling. Terrific for golf carts.

And with our optional 110 volt adaptor you'll find endless uses wherever house current is available ... At your cottage ... as a bar fridge ... in your motel room for a midnight snack and drink ... as a small office fridge ... or beside your pool. Use as an auxiliary home fridge when you're having a party. And it's a natural at drive-in movies, auto races and at sporting events.

**MODEL P34 -
THE PERFECT
RECREATIONAL FRIDGE**

\$169.00
(in Canada
\$179.00)



Holds over 40 lbs. of food and beverages or 48 pop cans. Refrigerates in air temperatures up to 95°F. Rugged ABS case in sand beige colour with dark brown non-corroding latches and handle. Large 34 litre capacity (1.2 cu. ft.) weighs 17 lbs. empty. Ext. 21" L x 16" H x 16" W. Int. 16" L x 12" H x 11 1/2" W. Operates on 12 volts DC with supplied power cord or with optional 12VDC/110VAC power adaptor.

The P34 is the full-size member of the Koolatron family of portable electronic fridges. It is designed especially for the serious traveler and outdoorsman. Newly designed for the 80's, this handsome improved portable will refrigerate more than 3 times the contents of the P10. As a hunter, camper, boater, you'll be amazed at the capacity and convenience.

Imagine dry, dependable refrigeration with the size to match your travelling and camping needs. Fits into any boat, van or camper or back seat of your car. Plugs into your cigarette lighter receptacle and refrigerates over 40 lbs. of food (no space wasted by ice), yet it draws no more power than the P10. With our optional 110 volt adaptor, you'll find endless uses as a bar fridge, cottage fridge, office fridge. Dazzle your friends at your next pool party with a full pay load of cold ones right beside the pool. Your P34 has all the advantages of the P10 without the heating cycle or low battery indicator but with all the capacity needed for serious boaters, campers, hunters, fishermen and travellers.

**MODEL P34A -
THE ULTIMATE RECREATIONAL
REFRIGERATOR &
FOOD WARMER**

\$189.00
(in Canada **\$199.00**)



The same size, colour, weight and capacity as the P34 but includes food warming features, fully adjustable temperature control and low battery warning indicator.

The P34A is our top of the line portable. It heats, it refrigerates and with specially designed electronic circuit control (patent applied for) it allows you to dial a complete range of temperatures from very cold to very warm.

READ WHAT OUR CUSTOMERS SAY:

"We took meat from Canada and ate it ten days later after thawing it in Florida. All our produce and drinks stayed unbelievably fresh and cool." S.H., Hamilton, Canada

"The way I try to sell my refrigerator one would think I was on commission. We love our unit!" P.O.P., Houston, Texas

"I am so pleased with the fridge I don't know how we got along before - it's so easy - to carry, use, maintain. For such a relatively small cost the convenience is inestimable." K.R., Ottawa, Canada

"The Koolatron is everything they say about it in its advertising. I personally bought one, tested it and found it so desirable that I gave it to my daughter and son-in-law who made a cross-country trek from Vermont to Oregon with their infant daughter. They told me that aside from their new Dodge van, the Koolatron was the most indispensable item of equipment they carried." K.M., New York, N.Y.

You wine buffs will find it indispensable to chill up to 1 doz. wine bottles at just the right temperature. Low battery indicator warns you when you need a recharge and the sensing circuits efficiently control your power consumption to save on battery drain. This is our best of the line, recreational fridge and food warmer with all the bells and whistles for the discerning buyer who demands quality, size and complete versatility.

ORDER TODAY WITHOUT OBLIGATION!

Simply complete the attached order form or phone collect and we'll rush you your portable on our no risk 21 day trial offer. Each unit comes with complete instructions and a written 1 year warranty. In the unlikely event you ever need service, we have major service centres in New York, Arizona and Canada. When you receive your Koolatron, use it constantly for 3 full weeks without risk.

If you ordered our optional 110 volt adaptor, plug it in, then use your portable immediately as a bar fridge or around the patio or pool. Next plug it into your car or RV. Take your family out for a weekend trip. Enjoy fresh home cooked food as you thumb your nose at those expensive restaurant stops. Then use it on your boat or in your office or let your son or daughter try it at their college dorm. If after you've thoroughly tested it, you don't agree that your Koolatron represents a major breakthrough that will save you time, money and bother for years to come, send it back for a full refund. You can't lose ... we guarantee it.

So be among the thousands to discover that the ice age is over! Don't waste another dollar on ice ... order your Koolatron with no obligation, today!

For rush delivery phone your order in collect to

0-705-737-0842

Koolatron Industries Limited
56 Harvester Ave., Batavia, New York 14020
230 Bayview Drive, Barrie, Ontario, Canada

Or use this handy order coupon.

Koolatron

Dept. 1082

Industries Limited

56 Harvester Avenue, Batavia, New York 14020
Canada: 230 Bayview Drive, Barrie, Ontario L4N 4Y8

Send me with full refund privileges:

- ___ Koolatron P10 at \$129.00 (\$139.00 in Canada)
- ___ Koolatron P34 at \$169.00 (\$179.00 in Canada)
- ___ Koolatron P34A at \$189.00 (\$199.00 in Canada)
- ___ Koolatron 110V adaptor at \$29.95 (\$34.95 in Canada)

Please add \$8.00 for handling and delivery per unit. No charge for shipping adaptor if ordered with unit. Add \$3.00 for shipping adaptor only. (N.Y., Ont. and Quebec residents add sales tax.)

I understand that I may return any item undamaged within 21 days and receive a full refund if I am not satisfied.

I enclose my check or money order for

\$ _____ or please charge it to my
 Visa Mastercharge American Express

Account Number _____

Expiry Date _____

Signature _____
(necessary to send merchandise)

NAME _____

ADDRESS _____

CITY _____ STATE _____

ZIP CODE _____ PHONE _____

DPSI

THERE'S MORE TO CUTLASS SUPREME THAN MEETS THE EYE.



Cutlass Watchers, compare Cutlass for mileage. Don't be attracted to this car just because of its looks. About a half-million people are going to buy a Cutlass this year and many will do so because of the V6 engine. This spunky, economical powerplant has an EPA estimated mpg of **20** and an estimated 27 out on the highway. With the available diesel V8 engine, you get even better mileage.

| | |
|---------------------------|----------------------------|
| V6 ENGINE | |
| 20 EPA Est. MPG | 27 Hwy. Est. MPG |
| DIESEL ENGINE | |
| 22 EPA Est. MPG | 34 Hwy. Est. MPG |

REMEMBER: Compare the boxed "estimated mpg" to the "estimated mpg" of other cars. You may get different mileage, depending on how fast you drive, weather conditions, and trip length.

Actual highway mileage will probably be less than the estimated highway fuel economy. Estimates lower in California. Diesel not currently available in California.

Oldsmobiles are equipped with GM-built engines produced by various divisions. See your dealer for details.

Compare Cutlass for comfort and flair. This mid-size is an Oldsmobile. The standard upholstery on the Brougham is a rich velour. The center armrest folds up to accommodate a third person in the front. Yes, this mid-size car seats six people... six adult-size people... in Oldsmobile comfort. Automatic transmission, power steering and power brakes are standard. And you can select from 78 other available luxury and convenience items that will make your Cutlass *your very own Cutlass*.



Compare Cutlass for its high resale value. It's a fact: Cutlass has one of the highest resale values among all mid-size cars. That's important when you're buying a car. Cutlass's high resale, in effect, can provide added value at trade-in time.

These days you owe it to yourself to compare before buying. Stop in at your Oldsmobile dealer today. He'll do everything he can to make you one of the half-million Cutlass Watchers who'll become Cutlass Owners this year.

It'll be mighty nice knowing that the Cutlass you bought was the right car to buy. †

No wonder Cutlass is now America's #1 selling car.



MARK OF EXCELLENCE

Oldsmobile

WE'VE HAD ONE BUILT FOR YOU

Alcohol fuels

— can they replace gasoline?

By RAY HILL

We hear a lot about alcohol these days. Depending on who you talk to, alcohol:

- (A) Will solve our fuel shortage.
- (B) Will provide partial relief.
- (C) Won't work in a car.
- (D) Is practical because you get more energy out of a gallon of alcohol than it takes to produce it.
- (E) Is impractical because it takes more energy to produce a gallon of alcohol than you get back in return.

What can you believe? Does alcohol have a role in our future? If so, what is that role? How hard is it to make a car run on alcohol?

To find out, I have spent the last few weeks talking to many scientists and experts in alcohol-fuel production, and to people who are running cars on straight alcohol, or gasohol (a 90/10 blend—nine parts gas to one part alcohol). I even drove an unmarked New York City police car that's been running on pure alcohol for the past six months.

Here's what I found.

It's been used before

Back in 1895 Nikolaus Otto, the recognized father of the four-stroke internal-combustion engine, recommended alcohol as a fuel.

After World War I, France used a 50/50 mixture of gasoline and alcohol in all government cars for a while. During the depression, many Midwestern farmers used home-brewed alcohol to power farm tractors. In the mid-'30's an alcohol-fuel plant was built in Atchison, Kans. Its product, Argol, was sold in hundreds of service stations throughout the Midwest. The plant shut down in 1939, unable to compete with cheap oil.

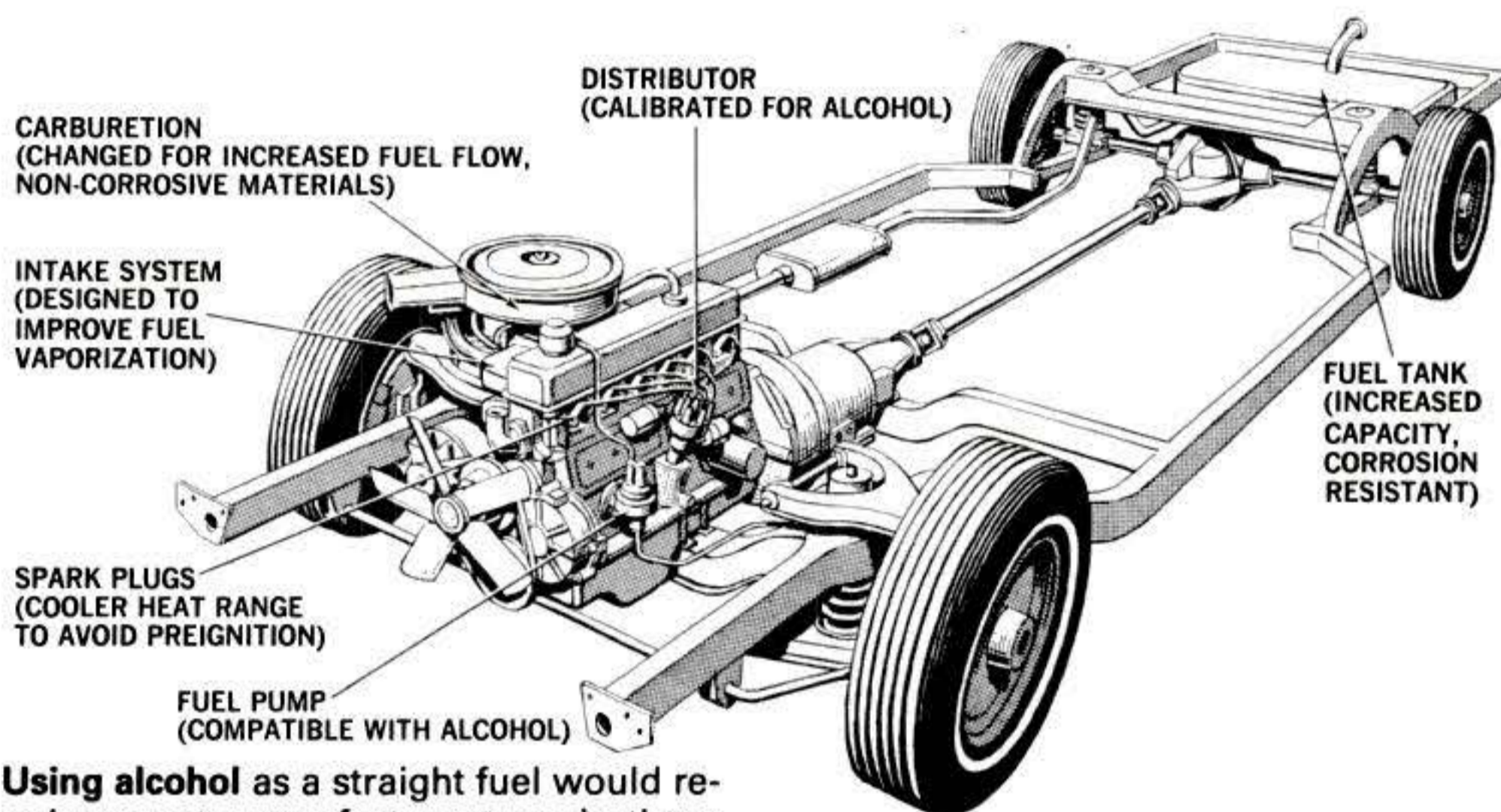

Using alcohol as a straight fuel would require an auto manufacturer to make these basic modifications to a car.

When the allies cut off Hitler's gasoline-supply lines during World War II, all of Germany's military vehicles ran on alcohol.

Except for special occasions such as these, though, the spark-ignited internal-combustion engine has been primarily fueled by gasoline derived from crude oil. When crude oil was plentiful and inexpensive, there was no need to look farther for fuel. But those days are past.

At current usage levels, the world will have used up its proven crude-oil supplies in 30 years. The most optimistic number, assuming no growth in oil consumption, is 75 years—but that includes our estimated resources as well as proven resources.

That's not a lot of time to develop alternative liquid fuels. (Experts agree these will be needed until, in the distant future, surface-transportation needs may be satisfied with vehicles powered by something other than liquid fuel.)

Right now, the alternative liquid fuel we know most about producing is alcohol. There are literally hundreds of forms of alcohol, most or all of them combustible. But for various economic and technological reasons, only two alcohols are attractive as liquid fuels—methanol and ethanol (sometimes referred to as methyl alcohol and ethyl alcohol).

Let's take a closer look at these two fuels.

Both are clear liquids. They smell much alike. Both have a much higher octane number than common pump gasoline. And both can operate over a wider range of air/fuel ratios than gas.

A gallon of alcohol can't match a gallon of gasoline in heat energy. A gallon of methanol has 56,560 Btu; ethanol 75,760 Btu; gasoline 115,400 Btu.

When burned at a stoichiometric mixture (basically, the air/fuel ratio that liberates maximum heat energy

Continued

A man in an orange jacket is leaning over the side of a boat, looking out at the ocean. He has a cigarette in his mouth. The boat's structure and rigging are visible in the background.

No compromise Winston Lights didn't compromise

Warning: The Surgeon General Has Determined
That Cigarette Smoking Is Dangerous to Your Health.

LIGHTS: 13 mg. "tar", 0.9 mg. nicotine, LIGHT 100's: 13 mg. "tar",
1.0 mg. nicotine, av. per cigarette, FTC Report MAY '78.

on great taste to get low tar.
Why should I?

Winston Lights taste good
like a light cigarette should.



Alcohol fuels

[Continued]

from a fuel), alcohol fuels use less air than gasoline. For gasoline the stoichiometric mixture is 14.7 parts of air to one part gasoline. For methanol it's 6.4 to one. And for ethanol it's nine to one. Not surprisingly, then, since each gallon of alcohol contains less potential energy than a gallon of gasoline, it takes more gallons of alcohol to move a car a given distance. To look at it another way, fuel consumption increases with alcohol.

"The bottom line is about a 50 percent decrease in miles per gallon with pure methanol compared to miles per gallon with gasoline," says Joseph Bidwell, executive director of General Motors Research Laboratory.

With ethanol, fuel economy is better. In Brazil, where 730 test vehicles running on pure ethanol for the past six years have accumulated more than 15.5 million kilometers in road tests, fuel consumption has increased only 10 to 20 percent, says Dr. Luis Pimental, a chemist with Brazil's In-

“Each gallon of alcohol contains fewer Btu than a gallon of gas, but its octane is higher”

stitute of Technology in Sao Paulo. How about emissions?

"If an engine were recalibrated for either methanol or ethanol, hydrocarbon and NO_x emissions would be lower than with gasoline," says GM's Bidwell. "Carbon monoxide emissions would be about the same. Unregulated emissions, though, primarily aldehydes, would increase considerably."

Dr. Pimental concurs with Bidwell. "We are directing additional research toward controlling and reducing aldehyde emissions," says Pimental.

Many experts believe a catalytic converter will decrease aldehyde emissions adequately if they are determined to be hazardous. Two who believe this are professors W. D. Harris and R. R. Davison of Texas A&M University. They have accumulated 55,000 miles on a Mazda Mizer and a Datsun pickup—both powered by pure methanol. Harris and Davison say they have tried a catalytic converter and it eliminated the aldehyde emissions. The converter was not specially designed, but merely one from a conventional gasoline-fueled car.

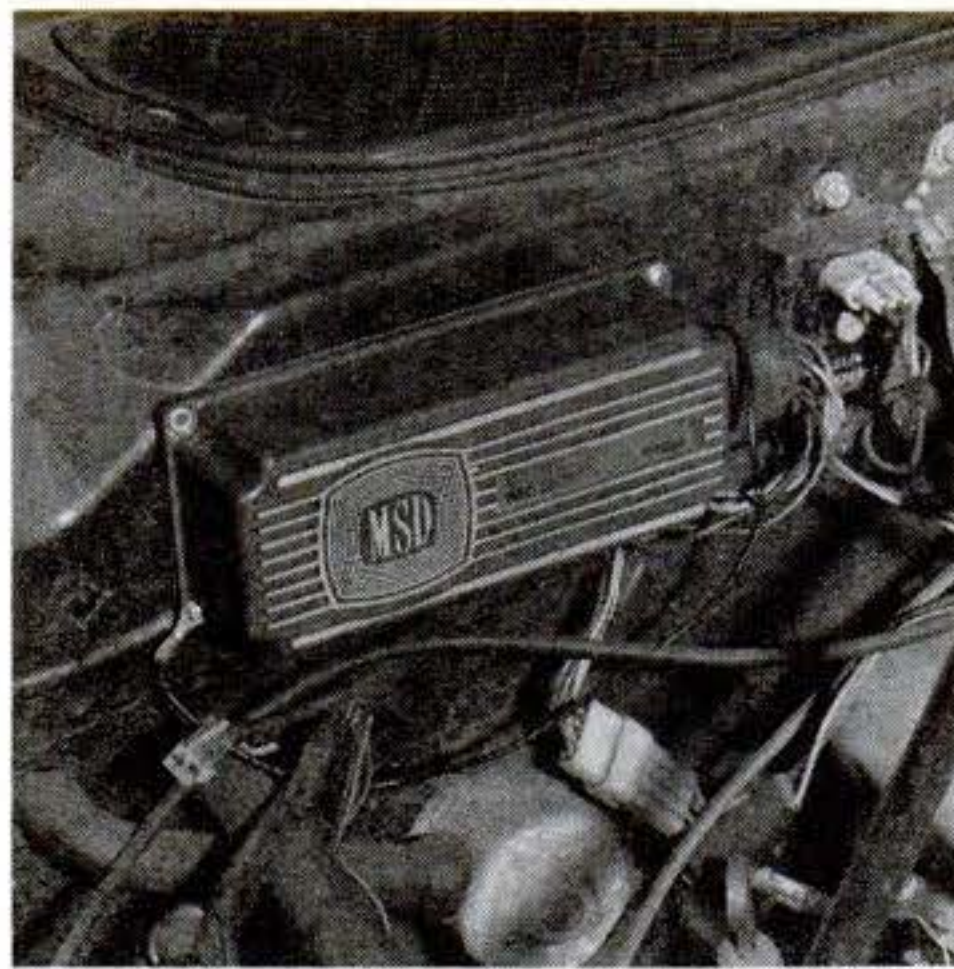

Multispark device on methanol-powered police car replaces electronic ignition's control unit and ballast resistor.

One problem with alcohol is that it is more corrosive than gasoline. To use pure alcohol in a conventional car, "specially formulated plastic, rubber, and metal linings would have to be developed for the fuel system to resist chemical attack," says GM's Bidwell. "While these modifications for corrosion protection and better engine performance appear feasible for new cars in the future, modifying cars already on the road doesn't seem to be a practical solution."

Two other problems: Because alcohol doesn't vaporize as easily as gasoline, it can be difficult or impossible to start an engine in cold weather using pure alcohol. And when used as a blend—part alcohol, part gasoline—alcohol can separate from the gasoline (phase separation) if a small amount of water is present in the gas tank. This can happen in the car's gasoline tank, or in the storage tank at the gas station that sells the blend. Methanol is more prone to both these problems than ethanol.

Solving the problems

Texas A&M professors Harris and Davison have solved the hard-starting-when-cold problem by converting the Mizer and Datsun pickups to dual-fuel vehicles; they start on gasoline, then switch to methanol. They've found it necessary to start on gasoline when the engine is cold and the ambient temperature is below 50 degrees F. "There is some stumbling when we switch over to methanol," says Harris. "But it's only momentary."

To fight corrosion they replaced the standard zinc-lined gas tank in each vehicle with a stainless-steel tank. The rest of the fuel-system components are stock. "There has been some pitting of standard pot-metal parts in the fuel system," says Harris. "It's not serious, though."

Gene Masci is the director of motor transport for New York City's huge

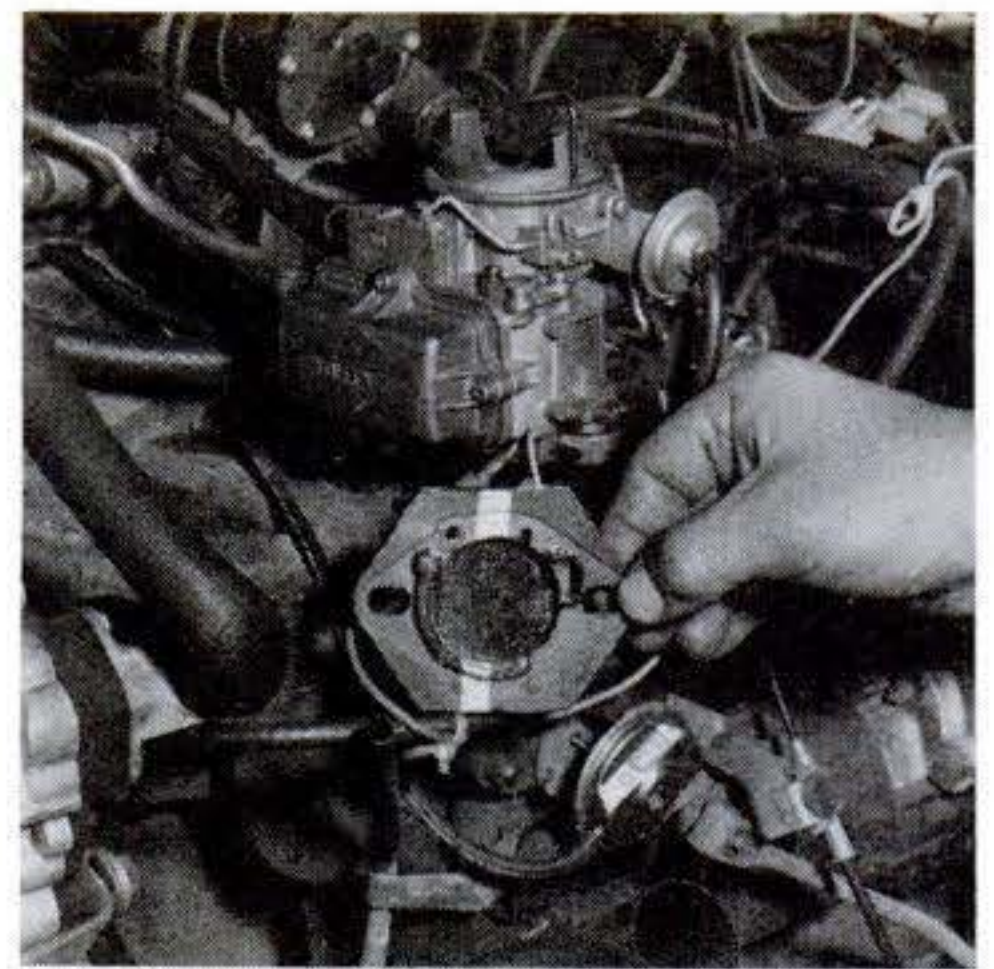

Electric grid between car's carburetor and intake manifold provides extra heat to improve methanol vaporization.

fleet of police vehicles. For the past several months he has been experimenting with alcohol fuels. His goal is to keep the police fleet rolling in the event of a gasoline cutback.

He has tried both ethanol and methanol blended with gas. With a methanol-gasoline blend, phase separation was a problem he couldn't overcome. With ethanol, however, he was able to blend as much as 20 percent ethanol with gas without any engine modifications "and still get acceptable engine performance," he reports. He had no phase-separation problems.

Although methanol did not work as a blend because of the phase separation, he has found that it works quite well as a straight fuel. Since June 1979, he has been running a 225-cubic-inch six-cylinder Plymouth on pure methanol. Parts used to modify the car cost \$400. They include a different carb, electric grid between carb and intake manifold (to help vaporize the methanol), an air pump (for emissions purposes), and a multispark device to replace the ignition's electronic control unit and ballast resistor. Used on some racing engines, the multispark device provides a series of

Continued

Specs for ethanol-fueled 1979 Ford Fiesta

| | ORIGINAL Unleaded gasoline | MODIFIED Ethyl alcohol* |
|----------------------------------|----------------------------------|-------------------------------|
| Primary fuel | | |
| Bore | 3.188 | 3.000 |
| Stroke | 3.056 | 3.056 |
| Displacement (cu. in./cc) | 97.6/1600 | 86.4/1416 |
| Compression ratio | 8.6:1 | 12.5:1 |
| Cam timing (degrees) | | |
| Intake: open | 29 (BTDC) | 16 |
| closed | 63 (ABDC) | 54 |
| Exhaust: open | 71 (BBDC) | 54 |
| closed | 21 (ATDC) | 16 |
| Static ignition timing (degrees) | 12 (BTDC) | 6 |

*180 proof (90% ethyl alcohol: 10% water) or 200-proof ethyl alcohol. Other ratios may also be tried. Fiesta was modified to run on ethanol by ADM (Cedar Rapids, Iowa), a major maker of ethanol fuel.



ENDED AT LAST. MAN'S 400-YEAR STRUGGLE TO MAKE A WATCH THIS SMART, THIS THIN.

Timekeepers first appeared on people's wrists shortly after the development of the mainspring; approximately 1540.

The geniuses of invention have worked to trim the size and bulk of the wristwatch, ever since.

Last year, in fact, Seiko set a record for flatness with a 2.5 millimeter quartz watch; it sold for \$5000. Yet for this unearthly sum, its owners could learn only the hours and the minutes of the day. Not a stitch more.

History has been made again. Now with an electronic liquid crystal quartz timepiece that approaches the thinness—but greatly exceeds the talent of Seiko's pride.

Its name is Xernus (pronounced *zer' nus*). And The Sharper Image brings it to you through the mail at the highly tempting price of just \$89.

Nobody else in America offers Xernus; if and when they do, it will most certainly be priced at \$150 or more.

The world's slimmest solar alarm chronograph.

How trim is this brainy piece of jewelry—that gives you the time with ± 15 seconds a month accuracy, the day and date, an alarm, a stopwatch and a solar-assisted battery—squeezed into a wafer?

Precisely 4.95 millimeters from the top of its mineral glass crystal to the back of its solid stainless steel case. (Xernus functions are further described in the face diagrams, below.)

Before you pick up your phone, we invite you to compare the thinness of Xernus to the world's remaining crop of solar alarm chronographs.

Seiko, an undisputed leader, sells a comparably talented timepiece for \$250; it measures 10.5 millimeters from top to bottom.

In the Under-\$150-League, competition for slimmness in alarm chronographs is even more dismal. Texas Instruments' is 12.0 millimeters thick; the Advance, 9.5 millimeters. And these are some of the thinnest.

Craftsmanship that's rare at even \$150 more.

Both case and bracelet of Xernus are machined from solid stainless steel, not plated base metal or "silvertone" (a material that pits and peels, often after only a few weeks of light use).

Once again, the face isn't scratch-prone plastic, but rock-hard tempered mineral glass.

And the manufacturer of Xernus is one of the few who dare to even mention water-resistance. Better yet, they guarantee your Xernus against water damage to 60 feet below the surface. (They're conservative; it has proven to survive in 90.)

Other Xernus distinctions? Mirrored face plating; a highly difficult technique that's just now beginning to

frame the displays on only the most costly digitals. A tightly meshed, smoothly polished bracelet that doesn't pull at skin or hair. Recessed function buttons that stay out of your way.

This unusual timekeeper is available to you in two different models: all Stainless or Gold (with a rich 5 microns worth over stainless). Incidentally, that's real gold, not "goldtone".

Xernus comes with full instructions, service-by-mail, if needed, a one-year manufacturer's guarantee against defects, and its battery in place. (Sensitive to sunlight or even dim roomlight, Xernus solar cells will keep this micro-thin battery working for up to 2 years. Replacements are available at most jewelers.)

And best of all, you have the chance to see a Xernus perform right on your wrist—before making your final commitment.

Keep it for two weeks. Wear it in water. And if for any reason you decide not to be a Xernus owner, simply send it back (in new condition, please). And The Sharper Image will return your entire investment without question. Including the delivery charge.

Time is of the essence. We can only guarantee the continuation of this introductory price through April 31, 1980. So order now.

ORDER TOLL FREE.

Credit card holders may use our toll-free number. Or send check for \$89 for Stainless, \$99 for Gold (in CA, add \$5.34 and \$5.94 sales tax, respectively). Plus \$2.50 delivery. Ask for product #942 (Stainless), or #943 (Gold). For our 40 page color catalog, write address below.

800 227-3436
In California 800 622-0733

THE SHARPER IMAGE™

260 California St., Dept. XT-051
San Francisco, CA 94111 (415) 788-8880

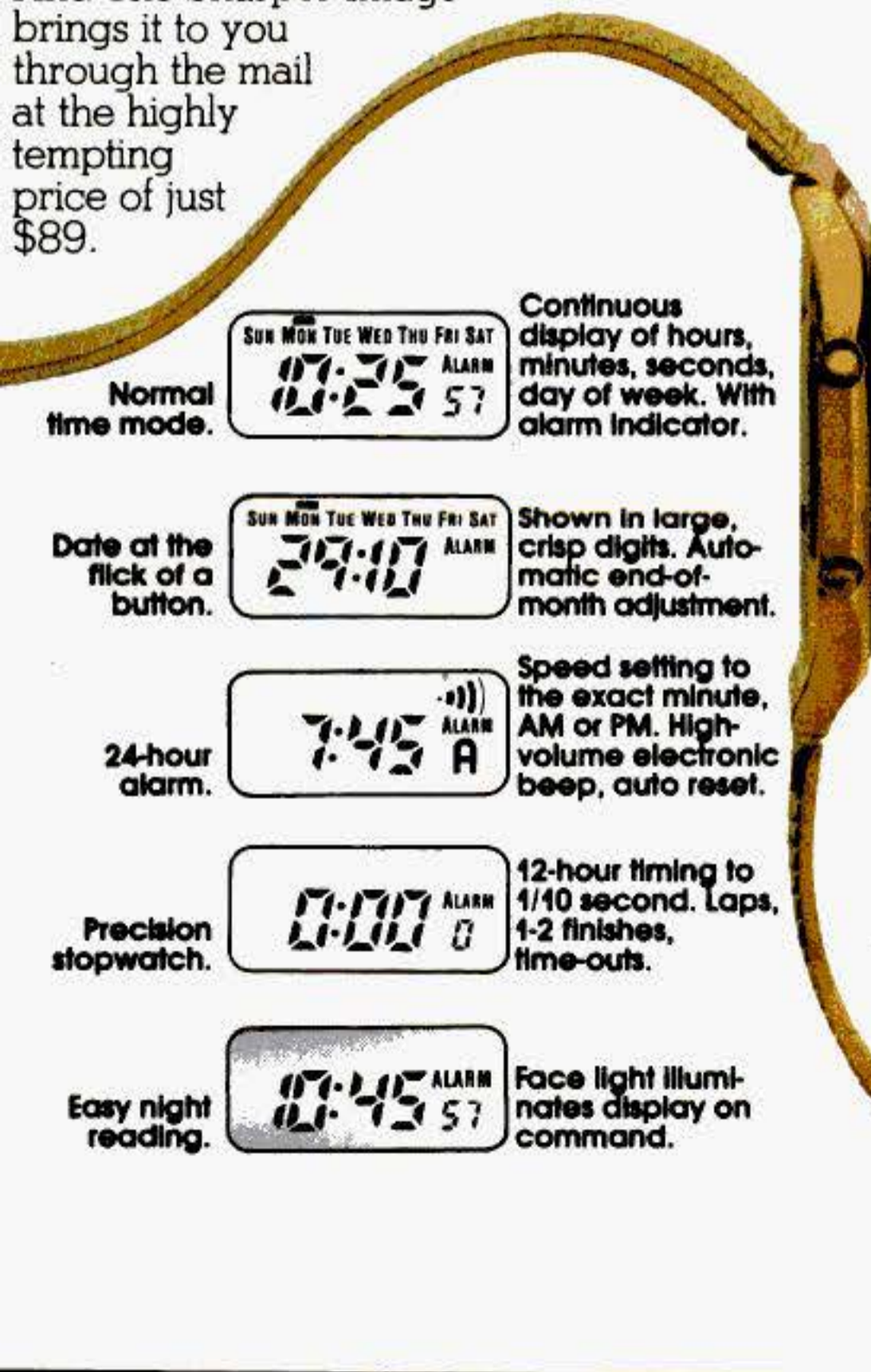

Normal time mode.



Continuous display of hours, minutes, seconds, day of week. With alarm indicator.

Date at the flick of a button.



Shown in large, crisp digits. Automatic end-of-month adjustment.

24-hour alarm.

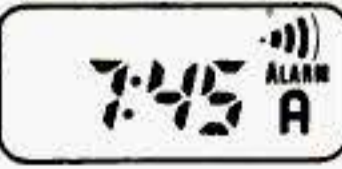

Speed setting to the exact minute, AM or PM. High-volume electronic beep, auto reset.

Precision stopwatch.



12-hour timing to 1/10 second. Laps, 1-2 finishes, time-outs.

Easy night reading.

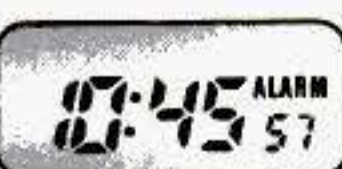

Face light illuminates display on command.

[Continued]

sparks to the plug, instead of one, for better combustion of the methanol, which doesn't burn as easily as gasoline.

Mileage has dropped considerably with methanol. EPA mileage testing of the stock engine tuned to specs produced nearly 15 mpg with gasoline, Masci says. With methanol, EPA testing showed 7.5 mpg. "Almost a 50 percent loss," he says. "So you're talking about a car with about half the range using the standard gas tank, which we are using. But police cars don't go that far patrolling their precincts."

What about hard starting? "So far, no problem," Masci reports. "But we haven't had real cold weather yet [this was in November '79]. I anticipate there will be some difficulties starting in cold weather."

Starting procedure is different, though, from that for a gasoline engine. The best technique, Masci says, is to turn the key on and let the electric grid warm up for about 30 seconds or so. And then turn the key to crank. "For about the first five minutes, performance is poor. After that, when the engine is warm, performance is great."

I drove the car for a few miles one morning after the engine was warm. It accelerated cleanly. There was no stumbling or hesitation, either under full or partial acceleration.

Corrosion, commonly associated with methanol, so far has not been a problem. In June 1979, when the methanol police car began running, Masci also filled a gas tank, removed from another car, with methanol. So far, the tank, sealed shut with tape and sitting in the police garage, has not corroded on the inside. Various fuel-system components have been placed in jars filled with methanol, and these too have yet to show any significant signs of corrosion. Undoubtedly the fact that the gas tank and jars are sealed has played some role in the results. But fuel systems of modern cars are pretty much sealed from outside air, too.

"For my purposes," he says, "even if corrosion were to cause me to replace a tank every two years, I could live with that."

(At press time Masci had installed an ether-injection system in the car. He reports that this solved the cold-start problem, even in below-freezing temperatures. The system is a commercially available unit used to start diesel engines. A temperature sensor causes ether to be injected directly into the intake manifold during cold

startups. When the engine is warm it is started normally.)

VW's methanol experiments

There is quite a contrast between Masci's practical, low-cost type of experimentation and Volkswagen's massive approach. Under a \$1.5 million contract with the West German Ministry for Research and Technology, VW has accumulated over 800,000 miles on 45 VW's fueled by an 85/15 blend of gasoline and methanol. Methanol was chosen because it can be produced from a variety of sources, such as coal, wood, grain, and garbage, say VW spokesmen.

Minor carburetor adjustments and replacements of methanol-sensitive carb floats, fuel filters, and seals with metal parts were the primary changes to the stock automobiles. Hydrocarbon, carbon monoxide, and nitrous oxide emissions have been reduced significantly, VW says. Fuel consumption is said to have been reduced about five percent, because the gasoline/methanol blend burns more efficiently than straight gasoline.

Phase separation was a major problem at the onset of the testing. But this has reportedly been solved by adding some isopropanol to the gasoline-methanol mixture.

Six cars were tested near the Arctic Circle using the gasoline-methanol mixture. No problems with cold startup or phase separation were encountered as long as some isopropanol was present in the blend.

Although VW engineers agree that significant changes would have to be made to an internal-combustion engine designed from the ground up to burn pure methanol, they believe such changes could be made without major difficulties.

Other auto makers are also testing alcohol fuels—and not just in the labs. Ford, GM, Fiat, and VW are heavily involved with developing ethanol-powered cars for Brazil. This year, fleets of these vehicles will be sold to the Brazilian government. And soon after, the makers hope to begin selling ethanol-powered cars directly to the consumer. The Brazilian government hopes to gradually replace all gasoline consumption with alcohol.

The engines in the cars sold in Brazil will be designed to take maximum advantage of burning ethanol. "Compression ratios will be around 12:1, compared to an average of 8:1 for gasoline engines," Dr. Pimental says.

Although testing so far with ethanol has produced a fuel-consumption

increase, more power is extracted from an engine, Pimental says, because of ethanol's high octane rating. "Under identical rotation and volumetric-displacement conditions, experiments at maximum power show that the ethanol engine can achieve about 20 percent more power than its gasoline counterpart," he says. "Even at minimum-consumption conditions, it is still six percent more powerful."

What about hard cold starting? "At temperatures below 59 degrees F, Pimental reports, "the cold ethanol engine has difficulty in starting because of the low vapor pressure of alcohol at those temperatures. So a cold-starting system needs to be added. One type we are using is an electric device that vaporizes a small amount of the ethanol. This has proven satisfactory, even as low as 14 degrees Fahrenheit."

Brazil began adding five percent ethanol (made from sugar cane) to gasoline back in 1931, and in later years increased the amount. "This was strictly for economic reasons,"

Switching to ethanol is proving feasible in Brazil. But is it practical in the U.S.?

Pimental says. "We wanted to provide a larger market for our sugar industry because of declining prices and increasingly inaccessible export markets. But now the situation has turned into something else. We're using more and more foreign oil. In 1940, 13.2 percent of our total energy needs was supplied from petroleum. In 1977 that figure had increased to 41.7 percent. Increasingly high petroleum prices, the decreasing world supply of petroleum, and the possibility of embargos and other problems have led us to the decision to turn to ethanol as a substitute for dependence on foreign oil."

Brazil's gasoline consumption for this year is estimated to be 17 billion liters. Brazil's present yearly ethanol production is 1.7 billion liters. By 1985, the government hopes Brazil's ethanol-production capabilities will have increased to something in the neighborhood of 10.7 billion liters.

The primary sources for ethanol in Brazil are, and probably will be, sugar cane and a plant called manioc. Brazil

Continued



1980 DATSUN KING CAB— THE ROOMIEST SMALL TRUCK IN HISTORY.

A DATSUN EXCLUSIVE! 2 REAR JUMP SEATS INSIDE THE CAB.

It took Datsun to come up with the biggest small pickup news in 20 years: the new Datsun King Cab® GL. With more space, legroom and luxury than you may experience in any small truck—including two reclining bucket seats up front and two jump seats behind that fold up to create more inside storage space than ever. That's "Grand Luxury" as only the King Cab GL can deliver it. With everything from cut-pile carpeting to a road-smoothing new ride.



GGONNA PICK YOU UP LIKE NEVER BEFORE.
When you add up the standards, no truck's gonna pick you up like the new King Cab GL. Check out this check list: • Styled wheels • Radial tires • Quad rectangular headlamps • Engine compartment lamp • 5-speed over-drive • Full instrumentation including tachometer • Quartz clock • AM/FM radio • Electric rear-window defroster • Center console • Even a dome lamp that swings down to light the cargo area.

DATSUN MILEAGE. MONEY IN THE BANK.
There isn't a bigger rig that can match Datsun pickups for economy. Yet Datsun trucks, with their gutsy 2-liter overhead cam engines, can haul 1400 lbs. of cargo and passengers—more than some bigger pickups. Now that's a truck you can drive all the way to the bank.

| | | | |
|---|-------------------------|-----------|-----------------------------|
| 25 | EPA ESTIMATED MPG | 32 | EPA ESTIMATED HIGHWAY |
| EPA estimates for comparisons. Actual mileage may differ, depending on speed, trip length and weather. Actual highway mpg will probably be less than est. California mileage lower. | | | |

**PERSONAL PICKUPS:
THE RIGHT CAB, THE RIGHT BED.**
For 1980, Datsun gives you choice like never before. From standard 6-foot beds... to the super-size Datsun long bed with over 7-feet of cargo length. And cabs ranging from Datsun's lowest priced Standard

THE TOUGH KEEP GETTING TOUGHER.
Over 37 percent of all small trucks on the road today are Datsuns. act to follow—but durability is a Datsun tradition built on quality. We test and retest under demanding conditions until every pickup is Datsun-perfect, and ready for a tough life ahead. Datsun trucks: their first job is to last. Test drive the big news in small trucks at your Datsun dealer—the small truck expert.

That's a tough



DATSUN WE ARE DRIVEN



Alcohol fuels

[Continued]

has an immense growing area, of which only a small proportion is currently used. Because of the long growing season and relatively mild climate, and the fact that Brazil has only about one-tenth as many vehicles as the U.S., switching to ethanol as a replacement for gasoline may be feasible there.

But is it practical in the United States? Can sufficient quantities of alcohol fuels be produced here to ease or eliminate our dependence on crude oil? And can they be produced and transported economically? The tech-

nology is no good if it's too expensive.

To answer these and other questions, the National Alcohol Fuels Commission, created by Congress, began functioning on June 27, 1979.

"Our key people," says Senator Birch Bayh, chairman of the commission, "are scientists and people who have done work in alcohol-fuel development before—engineers, chemists, and others. We will fund original research, conduct hearings, make literature searches, synthesize current knowledge in the field, and so on. In short, our job is to obtain the best in-

formation we can, then extrapolate from that concrete recommendations for Congress."

Dr. Edward Bentz Jr., director of the commission, had this to say about alcohol fuels.

"Ethanol currently has a couple of advantages. One, for every three percent of ethanol you add to the gasoline mixture, you get roughly an octane increase of one. That's a lot, because if your car is knocking and pinging—as many new cars using unleaded gasoline do—ethanol can eliminate the problem by raising the octane.

"Another benefit that's not as well known is that, in many cases in the U.S. today, our refineries are pretty much at their limits in terms of capacity. And when they have to make unleaded fuel without using a chemical additive like MMT—because it's environmentally banned—they have to work harder at the refinery level to get that equivalent octane rating for the yield of gasoline that they want coming out. That puts a slight capacity penalty on the refinery. Now, if you can add ethanol to gasoline—in the form of gasohol—you get that octane boost at the tank rather than at the refinery."

The attractive thing about alcohol fuels, says Bentz, is that methanol can be produced from wood, a renewable resource. It can also be produced from coal. Coal, of course, is not renewable. But we have vast reserves of it (see box). Ethanol can be produced from several renewable resources, such as grain and crop wastes (cornstalks, for example). It can also be produced from materials that have cellulose in them (such as organic garbage).

Critics' arguments

But this brings up one crucial question, one in which there is much controversy. Does it take more energy to produce a gallon of alcohol than you get back?

Critics of gasohol say it does, that the natural gas and oil used to fire the boilers of the distilleries that produce 200-proof ethanol for gasohol could be put to better uses. Dr. James Kendrick, an agricultural economist from the University of Nebraska, says it takes in the neighborhood of 130,000 Btu to produce a gallon of ethanol that he values at about 84,000 Btu. Other critics cite similar figures. "It's kind of like a businessman who spends \$10 to make \$5," one told me.

In addition, critics argue, ethanol is more expensive to produce than gaso-

Continued

BRING ON YOUR TOUGH JOBS



Mow 3 acres in an hour. Plow 8" deep. Front load ½-ton bucket loads into a pick-up. Till, cultivate, bulldoze, blow snow...get your tough jobs done fast!

Power King's dependable cast iron engine provides high-torque workpower. Rugged, all-gear drive delivers nearly 100% of engine power to big, ground-gripping drive wheels...squeezes more work out of every drop of fuel. Ground clearance up to 19" lets you cultivate tall crops and work in rough ground.

Get American-made Power King in 12, 14, 16 and 18 hp models and over 20 man-sized attachments. See your Power King Dealer for a test drive or write for free catalog.

POWER KING

ONE TOUGH TRACTOR

ENGINEERING PRODUCTS CO., INC. 1005-A3 ANOKA AVE., WAUKESHA, WI 53186

Copyrighted material

Now you can create country fresh air in your home or office. And also watch cigarette smoke, pollen, dust, and other airborne particles disappear from your environment, for less than three cents a week.

All it takes is a small 2½ pound pollution fighter named Ionosphere™. Which, we're convinced, is the most superbly engineered under \$200 air ionizer on the market today. Bar none.

The Sharper Image is offering Ionosphere through the mail for just \$89.

Ionosphere purifies the air you breathe more efficiently than any fan, exhaust unit or conventional filter system

by creating a negative electrical field. One 4-inch unit will ionize up to 250 square feet, or an average 12' x 20' room. This negative charge acts on floating particles—even invisible ones—causing them to cluster, fall to the floor or adhere to nearby surfaces. The air becomes pure, feels almost "washed." And Ionosphere is so efficient it requires no fan or other moving parts to disperse these ions.

You probably have experienced this fresh-air feeling before. In nature, negative ions are continually recreated by the dynamic action of the sun, rain and lightning. It's why air smells sweet and invigorating after a thunderstorm, or deep in a forest.

Born in academia.

Major ion research has been conducted at the University of California, Berkeley. Ion Systems, Inc., a private company, was founded to manufacture ionizers to the rigorous standards of this research community. Headed by senior engineer D.A. Gehlke (formerly with the government's Polaris Project), I.S.I. has built almost every hospital ion system in the U.S. Their new portable Ionosphere is constructed with this same level of integrity.

Ionosphere's electronics are both superb and unique. It is the only ionizer that uses "passive multi-stage" circuitry for its noiseless and noninterfering output (many units are known to affect radio reception). Most other units use a "vibration" mechanism, which causes clicks, pops or an annoying high-pitched whine.

The circuitry is embedded in epoxy resin, then encapsulated in an impact-resistant sphere—a solid seamless ball of fine ceramic tile. Hermetically sealed, it is protected from the moisture that inevitably reduces the performance of competitive units. We know of no other company that takes

such pains in producing their product.

Other significant differences? For one, a vastly superior ion emitter than you'll find elsewhere. This easily removable element is made from surgical stainless steel bristle, not the more commonly used copper "fuzz" or nickel-plated points. (These have short life spans, do not clean easily, and in short time lower their output.) The Ionosphere's emitter will last a lifetime, and cleans easily under hot water.

On other units, you'll also find inexpensive plastic cases. When exposed to a high voltage field, these petrochemicals can be converted to a harmful gas. But Ionosphere's tile case is completely safe.

More ions aren't necessarily better.

One 4" Ionosphere generates approximately 3.8 trillion ions every second. Unlike other units which produce an excessively high output (at the source only), the Ionosphere creates a more *naturally* balanced ion environment. You should also avoid units without stated levels of ozone production (Ionosphere is among the lowest).

Why do we need ionizers at all?

Urban life has upset the natural electrical balance of the air. Modern conveniences like heating, air conditioning, telephones and televisions greatly deplete negative ion levels, robbing the air of its natural cleansers. This is also why we feel uncomfortable under fluorescent lights.

Ionosphere restores this balance in just minutes. The air smells good again, even after smoking.

And, as a result of its work, you may need to clean your walls in a year or so. But be glad that same soot was kept out of your lungs.

Try one, or order a system.

The \$89 Ionosphere comes in white (#946) or black ceramic (#945). Or you may expand your fresh air environment at an \$18 savings—with three units at \$249; 2 white, one black, (#947). Either way, you can experience the freshest air you've probably ever breathed, without obligation. Ionosphere comes with full instructions and a one year warranty. And if you're not delighted, simply return your order within two weeks for a prompt and courteous refund.

ORDER NOW TOLL FREE.

Credit card holders may call the toll-free ordering number, seven days a week, anytime. Please have the product number ready. Or send your check, adding sales tax in CA (5.34 for one, 14.94 for three). Plus \$3.50 delivery. Please order now to insure early delivery.

800 227-3436

In California 800 622-0733

THE SHARPER IMAGE™

260 California Street, Dept IS-051
San Francisco, CA 94111
(415) 788-8880

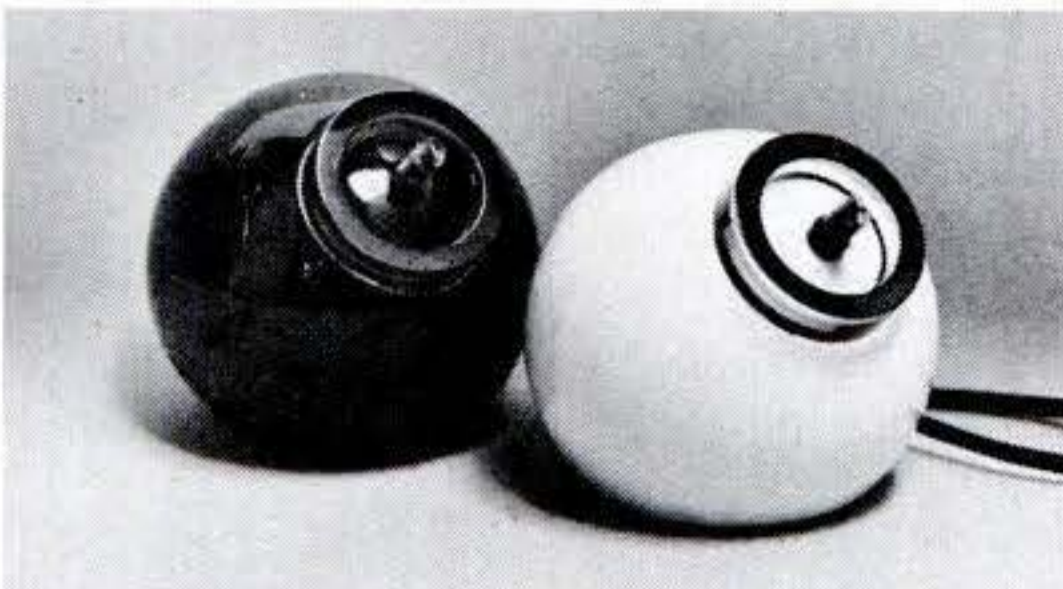

Power use: approximately 3 watts. Total ion output: 3.8×10^{12} ions/sec. Ion density: 10,000 ions/cubic centimeter at 8'. Ozone production: less than .03 ppm. N_2O production: not measurable.

THE AIR IONIZER WITH THE SCIENTIFIC EDGE.



Alcohol fuels

[Continued]

line. In the U.S., a gallon of ethanol costs between \$1.50 and \$1.75 a gallon. Gasoline is not yet that expensive. Gasohol (which uses 10 percent alcohol) competes with gasoline only because of a government subsidy that reduces motor-fuel taxes on gasohol. These decreased tax revenues must be made up elsewhere, or else result in reduced government services, they argue.

"It's probably true," says Lane Harold, a professional engineer and key researcher at the commission, "that today we're probably spending just as much or more energy to distill ethanol from grain as we get out of it. But that's because all the plants currently making ethanol now were originally set up as beverage-alcohol plants.

"They were originally designed to produce high-quality taste and high-purity drinking alcohol—not 200-proof alcohol to burn as a fuel. A lot of the older plants were built at a time when energy was cheap. It was sometimes better to save capital than it was to save energy."

Extensive review

But it doesn't have to be that way, Harold, Bentz, and others at the fuels commission point out. The commission was, at press time, just finishing a vast alcohol-fuels study—"the most extensive and important study of its kind yet done, we feel," says Bentz. It looks at ethanol and methanol fuels produced by various current technologies and estimates the energy pluses and minuses in various ways.

For example, the study calculates how many Btu of liquid-petroleum fuels will be made available for each gallon of corn-derived ethanol produced. An exact number wasn't available as we wrote this, but the commis-

sion was confident that the number would be positive, that several thousand Btu of liquid-petroleum fuels would be saved for each gallon of corn-derived ethanol produced.

In arriving at this number, however, a couple of important assumptions are made. One, that a modern, highly efficient, 50-million-gallon-per-year coal-fired distillery is used to make the ethanol (currently there are no coal-fired distilleries in America, although the technology is there to build them); two, that the fuel is used as a blend, not as a straight fuel.

The study also looks at ethanol derived from cellulose. Cellulose is found in a lot of materials, most notably garbage—of which we have plenty. Many people in the U.S. are working on making ethanol from cellulose. Among the leading technologies are the Gulf Process, now being used by George Emmert at the University of Arkansas; the Tsao Process, used by George Tsao at Purdue University; and the Natick Process, being used by Leo Spano in Natick, Mass.

Using the Gulf Process, the study estimates how many Btu of liquid petroleum fuels would be freed for every gallon of ethanol made. Again, the study assumes the ethanol would be used in a 90/10 blend. Preliminary data indicate that several thousand Btu of liquid-petroleum fuels would be freed using this process.

The study looks at methanol, too, but not as a blended fuel for automobile engines. "That's because, at present, we're not sure that the phase-separation problem can be solved without an additive that could be too expensive. This doesn't at all, however, rule out the possibility that methanol may indeed become either part of a blend or used as a straight fuel,"

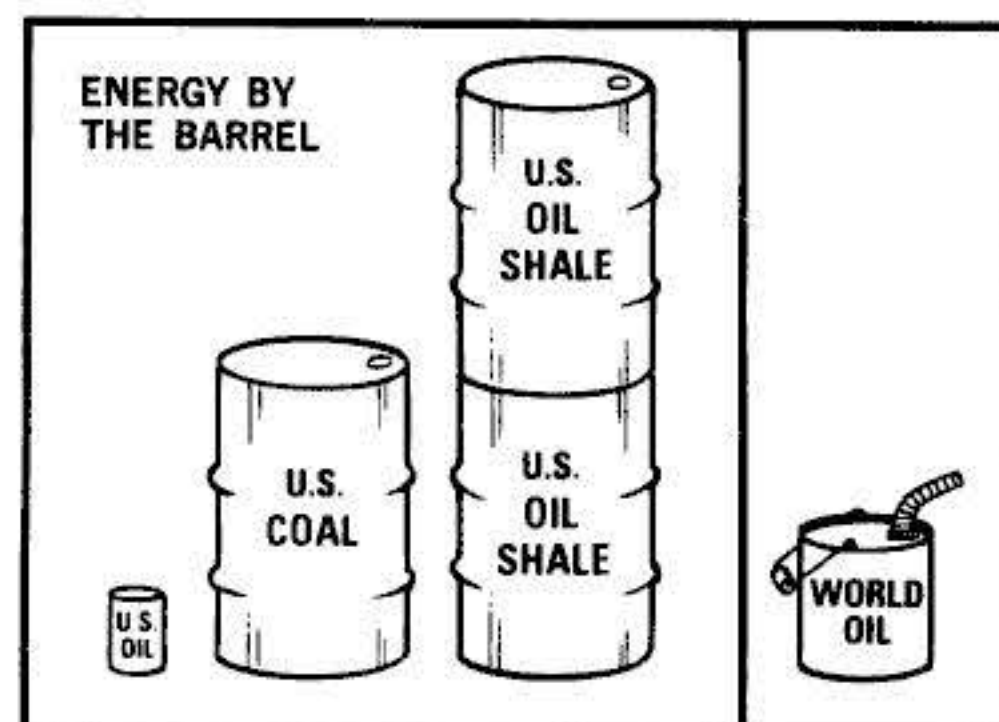

GM research scientists equated U.S. supply of coal and oil shale to barrels of oil—27,500 billion barrels for oil shale, 13,400 billion barrels for coal, plus 91 billion barrels of petroleum. World oil-supply total is 1800 billion barrels.

Bentz says. Savings in natural gas, from which most methane is made, are expected to be considerable.

No panacea, but a part

What does the future hold for alcohol fuels? Nobody knows for sure, of course. But many experts feel that alcohol fuels will play some role. Perhaps the Alcohol Fuels Commission's Harold summed up many of their feelings best. "We aren't suggesting that alcohol fuels are a panacea for our country's future energy needs. They take their place among a whole field of alternative-energy possibilities. No one can say now what the percentage of contribution of each one will be.

"Several of the other processes are much more unproven than ethanol and methanol. So we really don't know how good they're going to be, relative to their capital investment, pollution, and so on," Harold says. "Ethanol, which is being used today, can take a large chunk of the action in five years. We can be making quite a bit of it by then. Methanol can come on stream in five to 10 years." P 5

Supply of U.S. domestic coal reserves (in years)
(Assuming total energy demand supplied by coal*)

| Item | No. of years' supply at growth rate | | | |
|--|-------------------------------------|-----|-----|----|
| | 0% | 1% | 3% | 5% |
| Proven reserves: 970 billion bbl. petroleum equivalent | 73 | 55 | 38 | 31 |
| Ultimate resources: 13,400 billion bbl. petroleum equivalent | 1008 | 242 | 116 | 81 |

*1978 base-year consumption = 13.3 billion barrels petroleum equivalent

Supply of U.S. domestic petroleum (in years)
(Assuming only petroleum demand satisfied*)

| Item | No. of years' supply at growth rate | | | |
|---|-------------------------------------|------|------|------|
| | 0% | 1% | 3% | 5% |
| Proven reserves: 29 billion barrels | 4.5 | 4.4 | 4.2 | 4.1 |
| Estimated resources: 91 billion barrels | 14.0 | 13.2 | 11.8 | 10.7 |

*1978 base-year consumption = 6.46 billion barrels

Supply of world petroleum (in years)
(Assuming only petroleum demand satisfied*)

| Item | No. of years' supply at growth rate | | | |
|---|-------------------------------------|----|----|----|
| | 0% | 1% | 3% | 5% |
| Proven reserves: 642 billion barrels | 27 | 24 | 20 | 17 |
| Estimated resources: 1800 billion barrels | 75 | 56 | 39 | 31 |

*1978 base-year consumption = 24.1 billion barrels

Somebody needs what you've already got. Pass it on.

You came out of the service with a lot going for you. Skill. Knowledge. And experience. And much of it didn't come out of a book or a tech manual. It came from somebody else. Somebody who took the time to pass along what he knew.

Well, what about you? You've got a lot to give, too. And you can do it. Part-time. In the Army National Guard.

In the Army Guard, you can make a difference. By working with people who



want to know what you know. By showing them the ropes. And watching them grow.

It's a satisfying job. The pay's good, too. And you'll be putting time against retirement benefits.

Check it out. There are a lot of people who want what you've got. Pass it on. In the Army National Guard.

See your local recruiter or call toll-free 800-638-7600 (except in Alaska, Hawaii, Puerto Rico and the Virgin Islands). In Maryland, call 728-3388.

**Help somebody.
Including yourself.**



The Guard belongs.

Faste Lights Salem Lights



Refreshing light menthol.
Low tar.
Satisfying taste.
The best selling low tar menthol.
Salem Lights.



The Best Of The Lights

Warning: The Surgeon General Has Determined That Cigarette Smoking Is Dangerous to Your Health.

10 mg. "tar", 0.8 mg. nicotine av. per cigarette, FTC Report MAY '78.

Copyrighted material

Four-wheel drives — go-anywhere performance for rugged terrain or weather

By **JIM DUNNE** and **ED JACOBS**
 PHOTOGRAPHS BY GREG SHARKO

Appearances are often deceiving. The current lineup of four-wheel-drive utility vehicles looks little different

from that of the past five years, but important changes in engine size, transfer-case design, and weight reduction have taken place. The go-anywhere ability of the 4WD's, however,

Continued

PS ratings— test report in a nutshell

The ratings are based on test results and measurements. Results should be read with the understanding that they reflect tests only on our sample cars. An excellent rating is 5 points; very good, 4; good, 3; fair, 2; poor, 1; very poor, 0.

| | AMC Cherokee | Chevrolet Blazer | Dodge Ramcharger | Ford Bronco | International Scout | Intl. Traveler turbo diesel |
|-----------------|--------------|------------------|------------------|-------------|---------------------|-----------------------------|
| EPA mpg | 0 | 0 | 1 | 2 | 0 | 3 |
| Acceleration | 4 | 5 | 2 | 3 | 4 | 0 |
| Braking | 5 | 2 | 3 | 3 | 3 | 4 |
| Handling | 2 | 2 | 1 | 2 | 2 | 2 |
| Maneuverability | 4 | 4 | 2 | 4 | 5 | 4 |
| Ride comfort | 2 | 1 | 1 | 1 | 1 | 1 |
| Quietness | 0 | 0 | 0 | 0 | 0 | 0 |
| Roominess | 4 | 4 | 4 | 4 | 4 | 4 |
| Visibility | 2 | 1 | 2 | 4 | 4 | 4 |
| Entry/exit ease | 3 | 3 | 3 | 3 | 3 | 3 |



Soft sand was no problem for these contemporary 4x4's (clockwise from foreground): International Scout, Chevrolet Blazer, International Traveler turbo diesel, AMC Jeep Cherokee, Dodge Ramcharger, Ford Bronco.

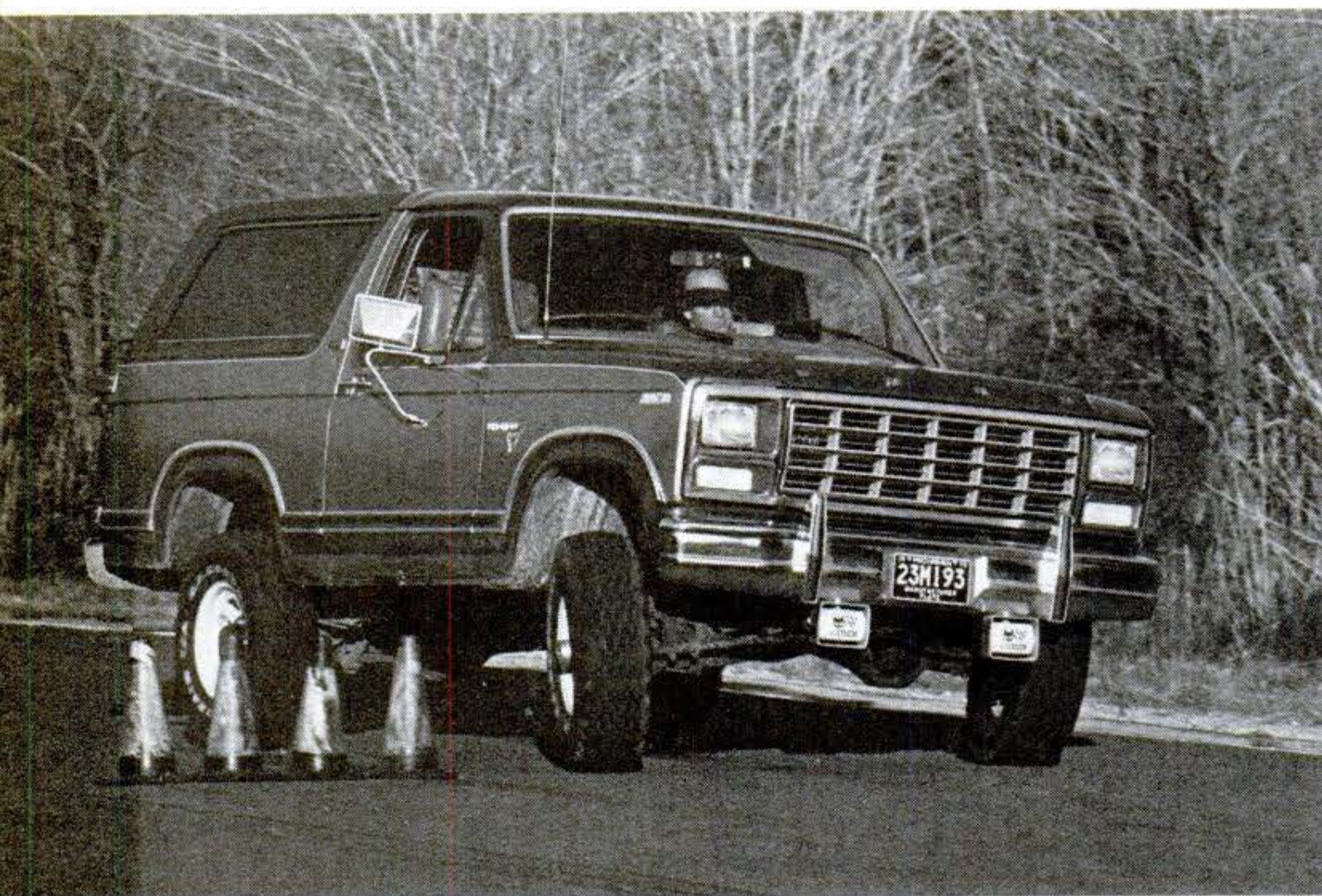

With a part-time system, there are certain things you must do to engage four-wheel drive. With the Dana-built system that International uses, you just move the selector lever to the drive range you want; nothing more is required. But, on the part-time system built by Chrysler's New Process Division, you must also get out of the car and rotate a locking mechanism on the front hubs to couple the otherwise free-wheeling hubs to the drive axles. Ford, Chevrolet, Dodge, and Plymouth use this system.

AMC's Cherokee is the only vehicle in this group with full-time four-wheel drive (also manufactured by New Process). It cannot be driven in two-wheel mode, which means that there's a fuel-economy penalty, but you don't have to manually engage four-wheel drive.

Don't be misled by the slick appearance of the vehicles in our test lineup; any can work well as a snow plow or long-range beach patroller.

American Motors Cherokee

Cherokee features an all-metal body and a roll-down window in the tailgate. The 360-cu.-in. V8 used in this test is not known for its fuel economy, but Cherokee is about average for vehicles of its type. Note that this Jeep is no weakling when it comes to trailer towing. Cherokee offers a class-high 7500-lb. towing capacity. And, like the rest of the Jeep family, it's ruggedly built to take the punishment of off-road operation.

Cherokee's interior is spacious and comfortable, and you can have virtually any accessory or convenience you want. There are also dress-up options for both interior and exterior.

While Cherokee offers about the same space inside as its biggest competitors, there is a problem getting into and out of the two-door's rear seat. The floor level is relatively high, and the seat-belt reel blocks a full four inches of the entry width.

Cherokee is unique among utility vehicles—it's available in both two- and four-door body styles.

Chevrolet Blazer

Blazer is the vehicle that changed four-wheel-drive design. In 1969, it was the first to use a pickup chassis as the basis for a utility vehicle, and the practice has now become an industry standard. Advantages are many, but the drawbacks are significant, too. Among them is poor visibility of the road directly in front of the vehicle, which is critical in off-road driving. In

Continued

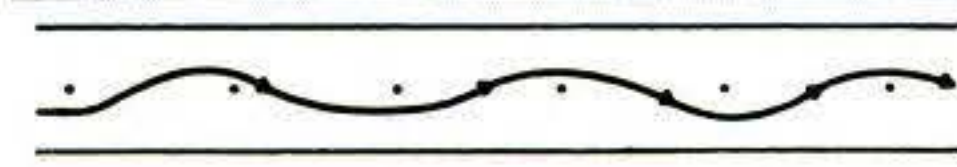

Some differences between independent-type and solid-axle front suspensions are readily visible here. Bronco's front axles

droop and take on pronounced positive camber (top) as the vehicle leans away from the camera in hard right turn. Scout's body (above) also rolls away from the camera, but its solid-axle front suspension stays parallel to the ground.

remains as impressive as ever.

This month we tested six rugged 4x4 designs: American Motors Cherokee, Chevrolet Blazer, Dodge Ramcharger, Ford Bronco, International Scout, and International Traveler turbo diesel. Though all six have something new to offer, Bronco and the Traveler turbo diesel are the most interesting.

This year Bronco has a new body and interior, independent front suspension with part-time four-wheel drive, slightly tidier overall dimen-

sions, and a 400-lb. weight reduction. The aim of it all: better fuel economy.

Part-time four-wheel drive isn't new; it was universally used in utility vehicles before full-time systems became popular five years ago.

The advantages of part-time four-wheel drive are all related to fuel economy. By disconnecting everything in front of the transfer case, you lower the demand on the engine, and get a six to 10 percent fuel-economy boost. International has always offered and favored part-time 4WD.



King Tote...Ford

**America's best MPG Van.
King-size payload, king-size economy.**

Ford vans are built tough. 1980 models can take up to 2,300 kg (5,070 lbs.—of payload—more than last year on most models). They're built for spacious comfort. Out-front engine design means plenty of move-around room for driver and passengers.

Above all, they're built for long-run economy. 1980 Fords have the best gas mileage estimates of any van. Plus an estimated highway cruising range that's *hundreds* of miles longer than others.

For comfort, payload, fuel economy—look into 1980 Ford vans. Ask your Ford Dealer about Ford's Extended Service Plan—and ask him about Ford's no-cost 36-month limited corrosion perforation warranty, a warranty that excludes exhaust system components. See your dealer for full details.



Easy comfort!
There's loads of room inside. Plus options like tilt steering wheel and Captain's Chairs that swivel and/or recline.

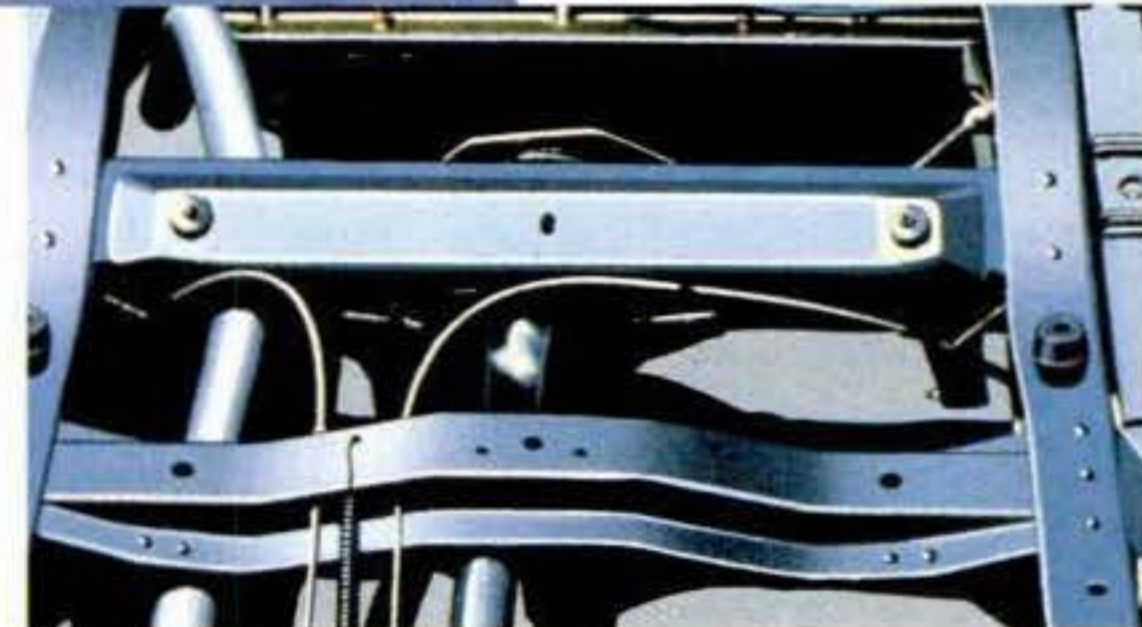

Tough frame! Ford vans have body-on-frame construction, cushioned by rubber mounts. And tough Twin-I-Beam suspension.

Best mpg ratings

18 EPA EST.* **26** HWY. EST.*

Standard 4.9L (300 CID) Six with optional overdrive transmission.

Longest estimated range

722 EST. MILES* **1,043** EST. HWY. MILES*

Std. 22.1-gal. tank plus opt. 18-gal. auxiliary tank on 138-in. wb. Total: 40.1 gals.

*Compare these estimates with others. Your mileage and range may differ depending on speed, distance and weather. Actual highway mileage and range will probably be less than estimated. California estimates lower.



Ford: Out front in van design.

FORD

FORD DIVISION



SPACE AGE PROTECTION FOR YOUR CAR'S FINISH.
THREE LAYERS DEEP. 24 MONTHS LONG.



THE NEW POLYSHELL™ SYSTEM FROM TURTLE WAX®

Weather. Pollution. Oxidation.

They all take turns beating the shine off your car's finish. But now the system is on your side—the PolyShell system from Turtle Wax.

An offshoot of space technology and Turtle Wax know-how, the PolyShell system locks three layers of protection between your car's finish and things that can kill it. Bonded

layers of Polymers and Silicones prime, shine and seal the finish.

There's even a Reactivator, which you apply every 6 months to bring the finish up to full shine and full protection for 24 months.

The PolyShell system is easy to apply. You don't need buffers or special tools. All the essentials are included. And it works for all car finishes.

Get the system on your side today. Ask for the PolyShell system from Turtle Wax.

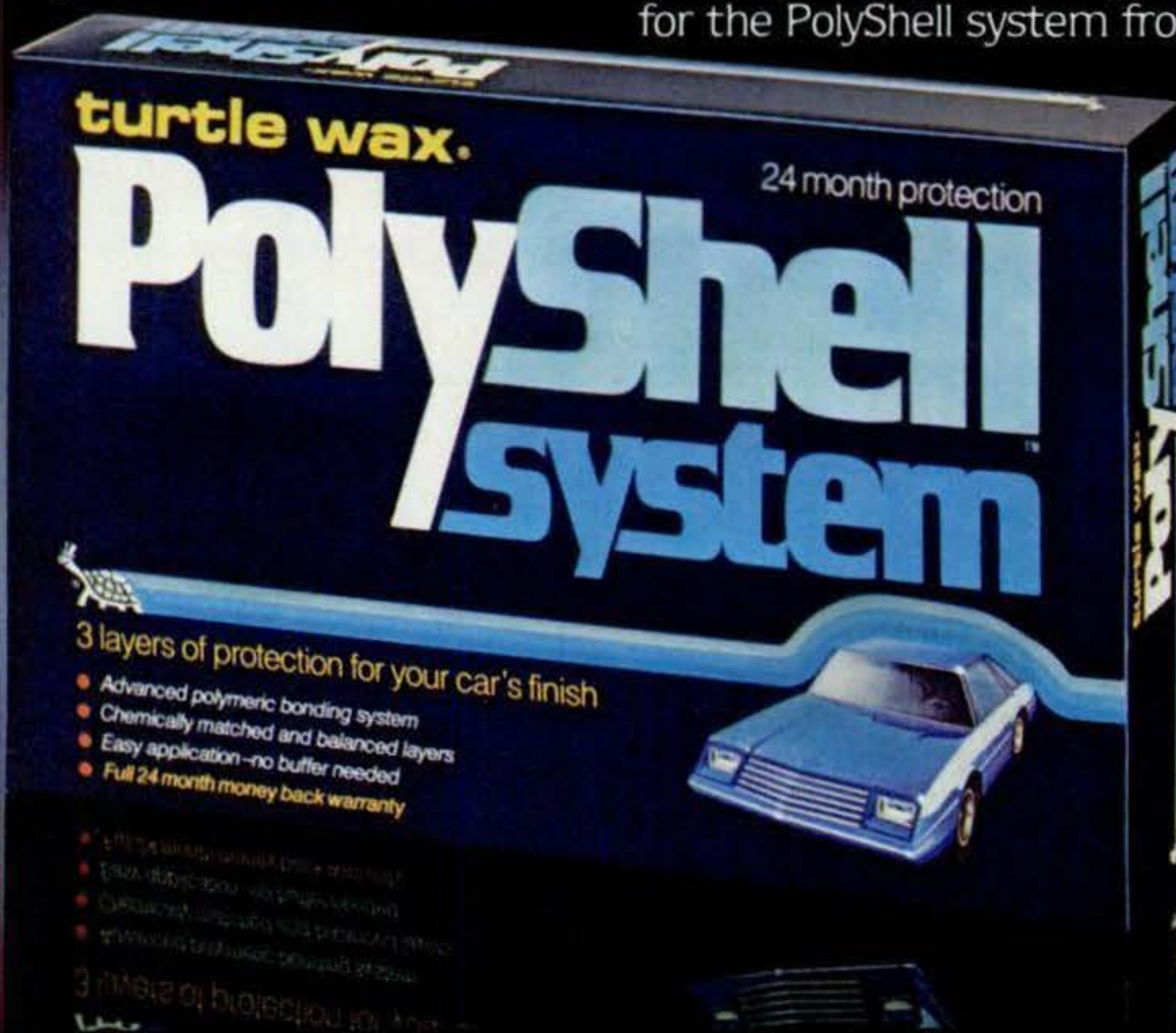

EPA fuel mileage (mpg)

| | AMC Cherokee | Chevrolet Blazer | Dodge Ramcharger | Ford Bronco | International Scout | International Traveler turbo diesel |
|-------------|--------------|------------------|------------------|-------------|---------------------|-------------------------------------|
| Highway | 16 | 17 | 16 | 18 | 17 | 24 |
| City | 11 | 13 | 13 | 15 | 12 | 20 |
| Calif. city | 12 | 12 | 11* | 13 | 12 | 20 |

*360-cu.-in. V8, only engine in Calif.

Observed fuel mileage
(steady-state mpg)

| | AMC Cherokee | Chevrolet Blazer | Dodge Ramcharger | Ford Bronco | International Scout | International Traveler turbo diesel |
|-------------------|--------------|------------------|------------------|-------------|---------------------|-------------------------------------|
| 35 miles per hour | 14.2 | 21.7 | 15.3 | 16.3 | 15.3 | 26.3 |
| 45 miles per hour | 13.5 | 19.0 | 13.9 | 14.6 | 14.2 | 24.0 |
| 55 miles per hour | 12.4 | 15.8 | 12.6 | 12.1 | 12.4 | 19.1 |

Dodge Ramcharger makes 60-mph panic stop to test maximum braking performance. Stops made with both cold and hot brakes check for dangerous fade.

addition, the body is much larger than many off-roaders require.

Blazer's Silverado package—with its tilt steering wheel, electric windows, air conditioning, and other conveniences—adds up to something close to the comfort of a big sedan. You pay for what you get, however—here, a hefty \$4500 over the base price.

The floor-mounted drive selector is mildly balky, but similar in operation to those in the Ford and Dodge. Its three positions—2H, 4H, and 4L—are easy to understand and find.

We were surprised, however, to note that the driver's seat has a fixed backrest, which means entry to the rear seat is possible only from the right side—inconvenient in our opinion.

Dodge Ramcharger

Ramcharger is the twin to the Plymouth Trailduster, and offers about the same combination of mobility, interior room, fuel usage, and comfort as the Blazer and Bronco.

Ramcharger is big and bulky, but we found its handling tidy. It is easy to control on or off paved roads, and it responds quickly and predictably to steering inputs.

The front seat is the equal in comfort of anything in the class. The layout for rear-seat entrance, however, isn't. The entire front passenger seat swings up and forward when you release a lever located behind the backrest, which you must blindly feel for when entering. Then, after entering, you must make certain the seat frame doesn't come down on your feet when it swings back into place.

Ford Bronco

A new body and chassis in a slightly smaller package haven't changed the

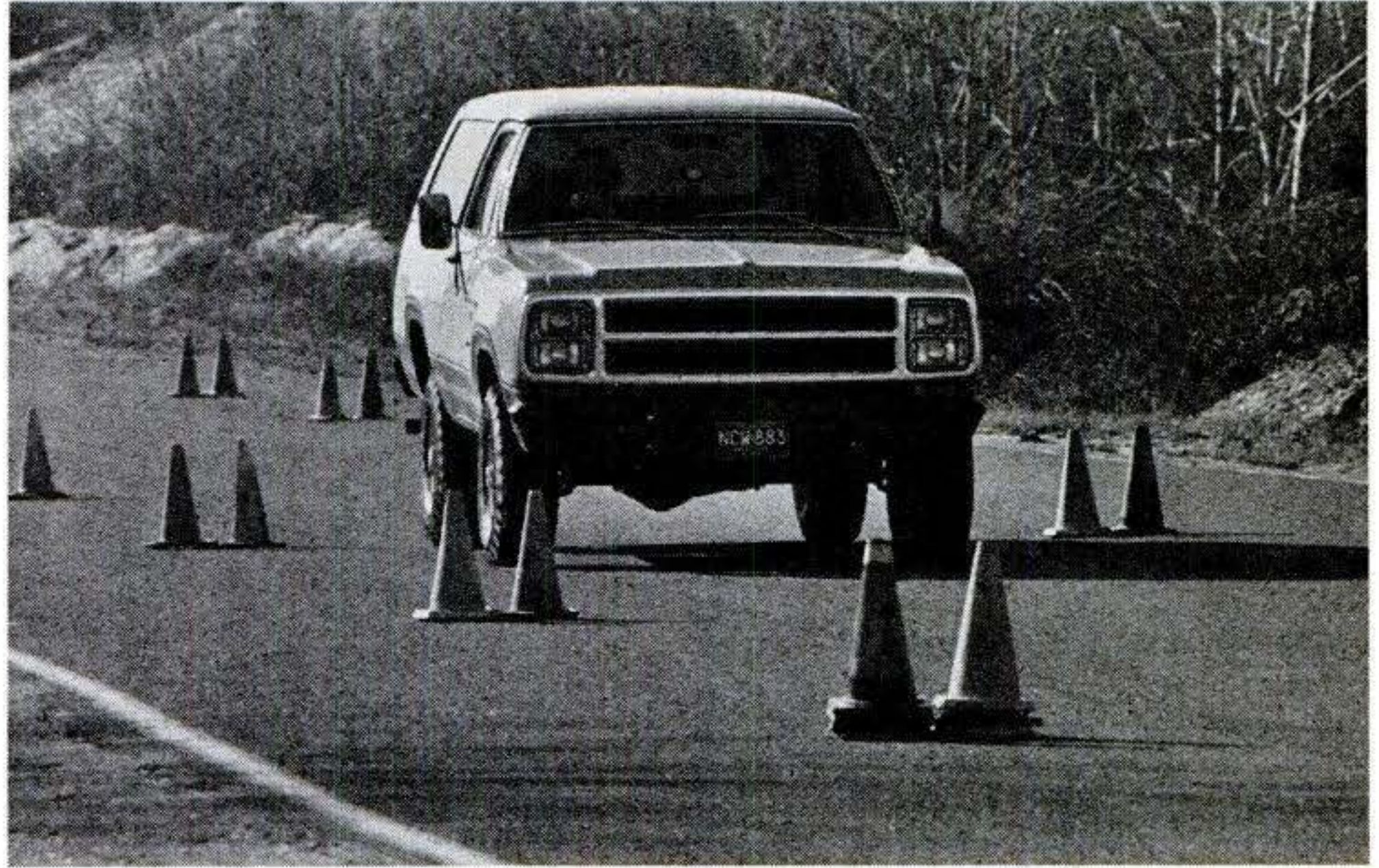

Bronco as much as you might think, despite the almost 400 pounds that were pared away. The earlier model's spacious interior dimensions are carried over, and the hood still looks enormous from the driver's seat.

Ford uses its new-for-1980 pickup-truck front end as the basis for the Bronco. Its high-production instrument and body panels promise better quality and easier-to-find repair and replacement parts (perhaps less costly, as well).

The new, independent-type front axle is unique, but offered no advantage in either handling or traction when compared with the conventional solid front axles of the other vehicles. Because the differential rides with the independently sprung axles, however,

there is a slight clearance advantage (less than two inches), which may be meaningful to some off-roaders.

The rear seat folds down and can be released at the touch of a single catch, opening up the interior to carry up to 102.6 cu. ft. of cargo. In addition, a large covered storage bin between the front seats will hide most bulky personal objects. (Similar layouts are found in all other 4x4's.)

International Scout

Scout is smaller than its cousin, Traveler, and has a different tailgate setup (horizontally divided doors, versus Traveler's single flip-up hatch), but is otherwise identical.

The 304-cu.-in. gasoline V8 engine

Continued

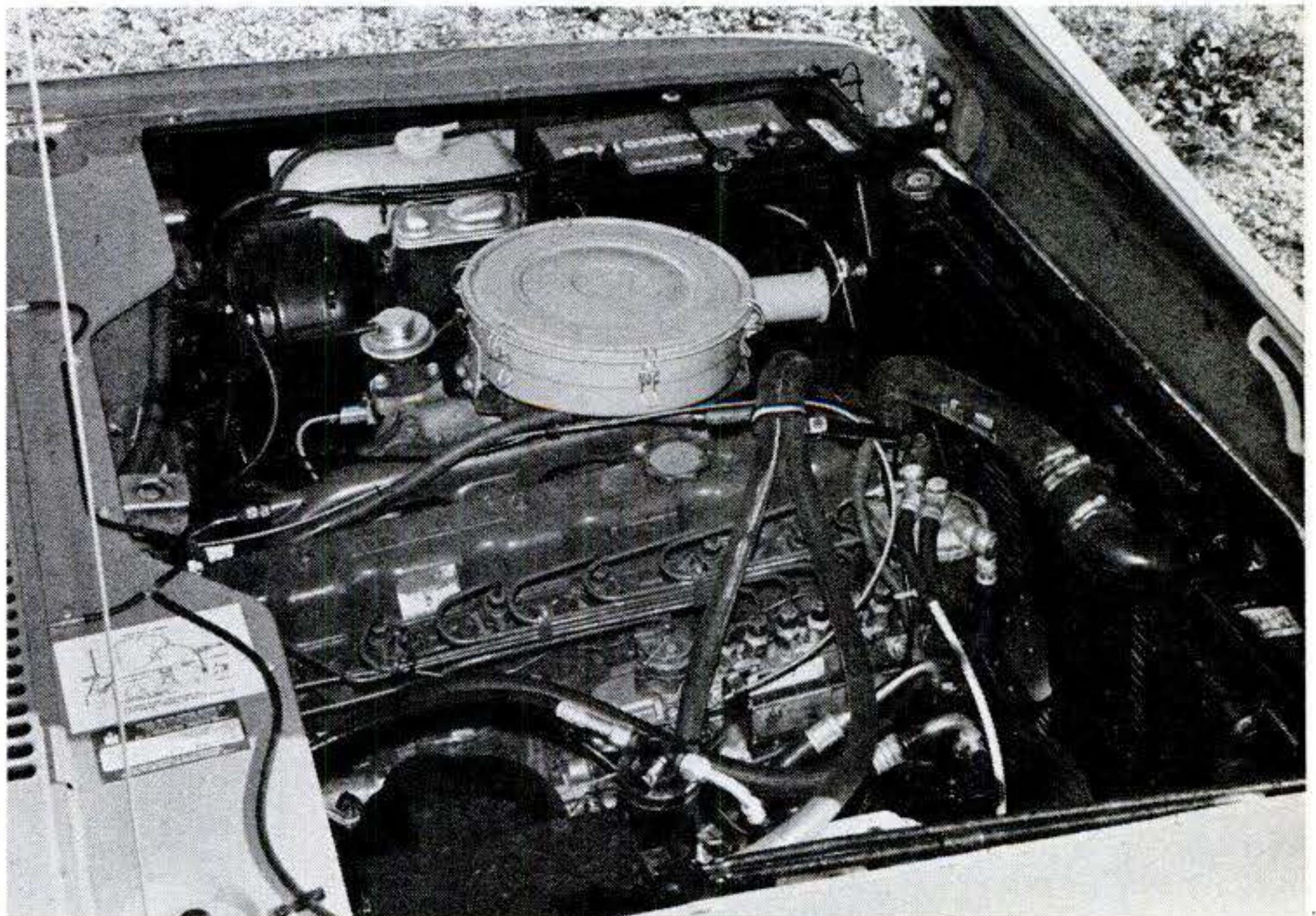

Six-cylinder Nissan-built diesel easily fits under Traveler's hood and leaves much

room to work. Turbocharger is neatly tucked out of sight on the other side.

is fully competitive with similar small engines from Ford, Chrysler, and GM. Performance is good, however, and the trailer-towing capacity is high.

International gives away nothing to the competition in the quality of its chassis parts. The husky engine, transmission, and transfer case have the feel of heavy-duty systems that will take abuse and not falter.

International now offers a five-year, 100,000-mile, no-perforation corrosion warranty on its models—an exclusive in the field. This is a very valuable asset.

International Traveler turbo diesel

The addition of a turbocharger to the Nissan-made six-cylinder diesel has meant a dramatic improvement in power, but Traveler is far from a high-performance vehicle. Acceleration from zero to 60 mph takes more than 26 seconds—almost unacceptable in today's traffic. But Traveler's diesel offers power where it counts, at low speed, and its performance is acceptable as a work machine.

Inside the cab, Traveler offers about the same kind of room and comfort as the Bronco, Ramcharger, Blazer, and Cherokee. Seats are big and comfortable, and a large storage bin between the front seats keeps valuables out of sight. Like the competition, Traveler

Performance comparison with selected models

| | Mpg (city driving) | Acceleration 0-60 mph (sec.) | Brakes 60-0 mph (hot) (ft.) | Handling (mph) | Maneuverability (mph) | Noise @ 60 mph (dBA) |
|-----------------------------------|--------------------|------------------------------|-----------------------------|----------------|-----------------------|----------------------|
| 1976 International Scout 6 diesel | 17 | 29.0 | 157 | 49.9 | 24.6 | 76 |
| 1976 Jeep CJ-7 V8 | 12 | 10.6 | 127 | 51.3 | 25.7 | 73 |
| 1978 Ford Bronco V8 | 10 | 14.9 | 149 | 53.0 | 25.3 | 71 |
| 1978 Chevrolet Blazer V8 | 10 | 12.8 | 182 | 54.5 | 26.8 | 74 |
| 1978 Jeep Cherokee V8 | 10 | 11.5 | 129 | 56.3 | 24.6 | 72 |
| 1978 Plymouth Trailduster V8 | 9 | 11.6 | 157 | 53.0 | 24.6 | 79 |

PS serviceability ratings

The numbers mean: 1, very difficult; 2, difficult; 3, average degree of difficulty; 4, easy; 5, very easy.

| | Checking fluid levels: Battery Master cylinder Windshield washer Engine oil Coolant | | | Checking the engine: Spark plugs Distributor Carb adjustment Oil filter Oil fill | | | Replacing hoses: Upper radiator hose Lower radiator hose Heater hoses | | | Changing bulbs: Headlights Taillights Front running lights Front parking lights Front directionals Rear directionals Rear running lights | | | Checking fuses Spare-tire accessibility Changing belts | | | |
|-------------------------------------|--|---|---|---|---|---|--|-----|---|---|---|---|--|---|---|---|
| AMC Cherokee | 5 | 4 | 5 | 3 | 4 | 1 | 4 | 3 | 3 | 4 | 5 | 3 | 4 | 4 | 3 | |
| Chevrolet Blazer | 5 | 4 | 5 | 3 | 5 | 3 | 2 | * 3 | 2 | 5 | 3 | 4 | 3 | 3 | 4 | 3 |
| Dodge Ramcharger | 5 | 4 | 5 | 3 | 5 | 4 | 2 | 3 | 3 | 4 | 5 | 3 | 3 | 3 | 3 | 3 |
| Ford Bronco | * 4 | 5 | 3 | 5 | 5 | 4 | 4 | 3 | 3 | 4 | 5 | 4 | 3 | 3 | 4 | 5 |
| International Scout | 4 | 4 | 5 | 3 | 5 | 3 | 3 | 3 | 3 | 2 | 5 | 3 | 4 | 3 | 3 | 3 |
| International Traveler turbo diesel | * 4 | 5 | 2 | 5 | 5 | † | † | ‡ 3 | 3 | 3 | 5 | 3 | 4 | 3 | 3 | 3 |

* Sealed. † Diesel, not applicable. ‡ Fuel injection.

offers spacious rear-seat room, with better legroom and headroom than any sedan.

If you're accustomed to truck machinery, you'll be right at home with Traveler. From the driver's seat, the speedometer is difficult to read, though. It's set to the right of the driv-

er, and, at highway speeds, the indicator needle is masked by the steering wheel.

Living with the diesel engine can be inconvenient, too. Starting a cold engine means a delay of a full minute or more, and, if our experience is any in-

Continued



Ease of routine maintenance is tested on all of the vehicles, as with Cherokee (top left). Swing-away spare-tire carriers like Bronco's (top right) give easy access to tailgate, but tires should be locked to carrier. The flexible plastic wheel covers on Scout (right) look like "mag" wheels. Fold-down rear seat in Blazer (far right) can be removed.

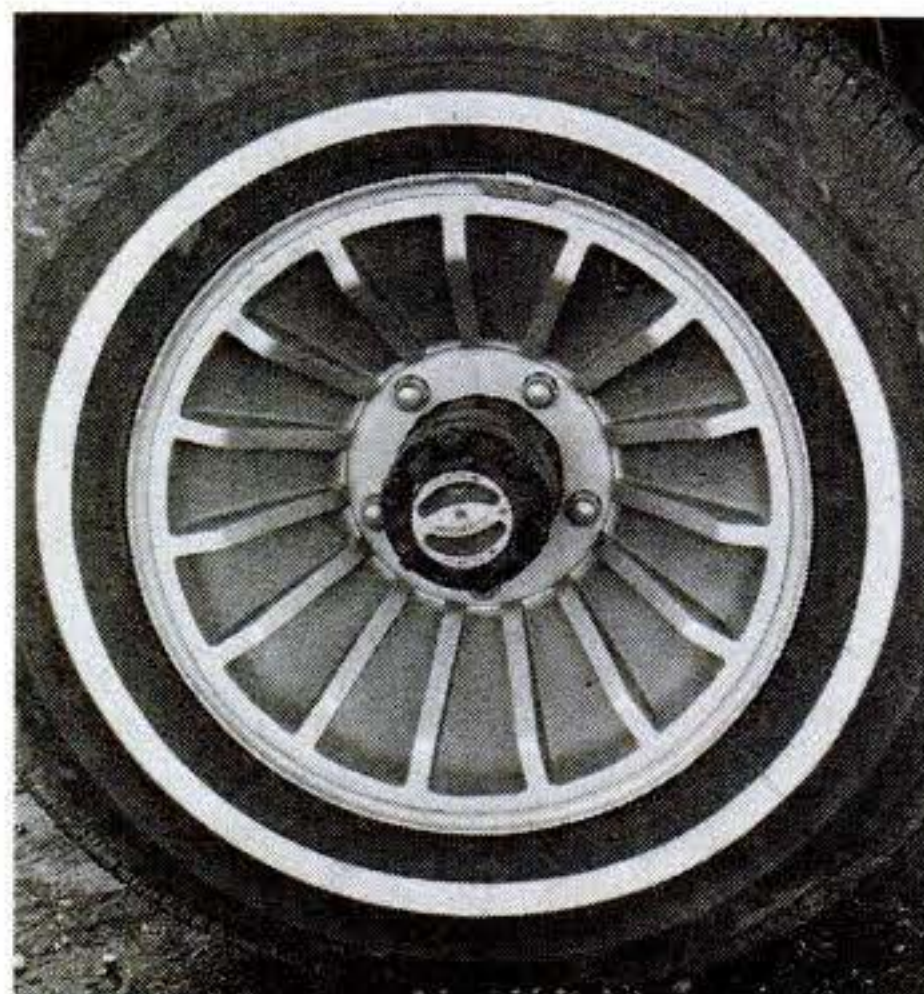

Save up to 80 gallons of gas with 1 change of oil.

We couldn't say it if it weren't true. Just change to Mobil 1[®] synthetic motor oil and if your car averages 15 miles a gallon, you can save up to 80 gallons of gasoline a year.

That's based on a high-mileage driving situation (if you drive 25,000 miles in a



year adding oil as needed).

Of course, if you only do half that amount of driving per year, you can still save up to 40 gallons.

Think of what you can do with all those extra gallons of gasoline. All it takes is 1 change to Mobil 1.

Mobil 1. The oil that saves you gas.

Revive your taste!



Newport Lights
*Newport pleasure comes
to low-tar menthols*

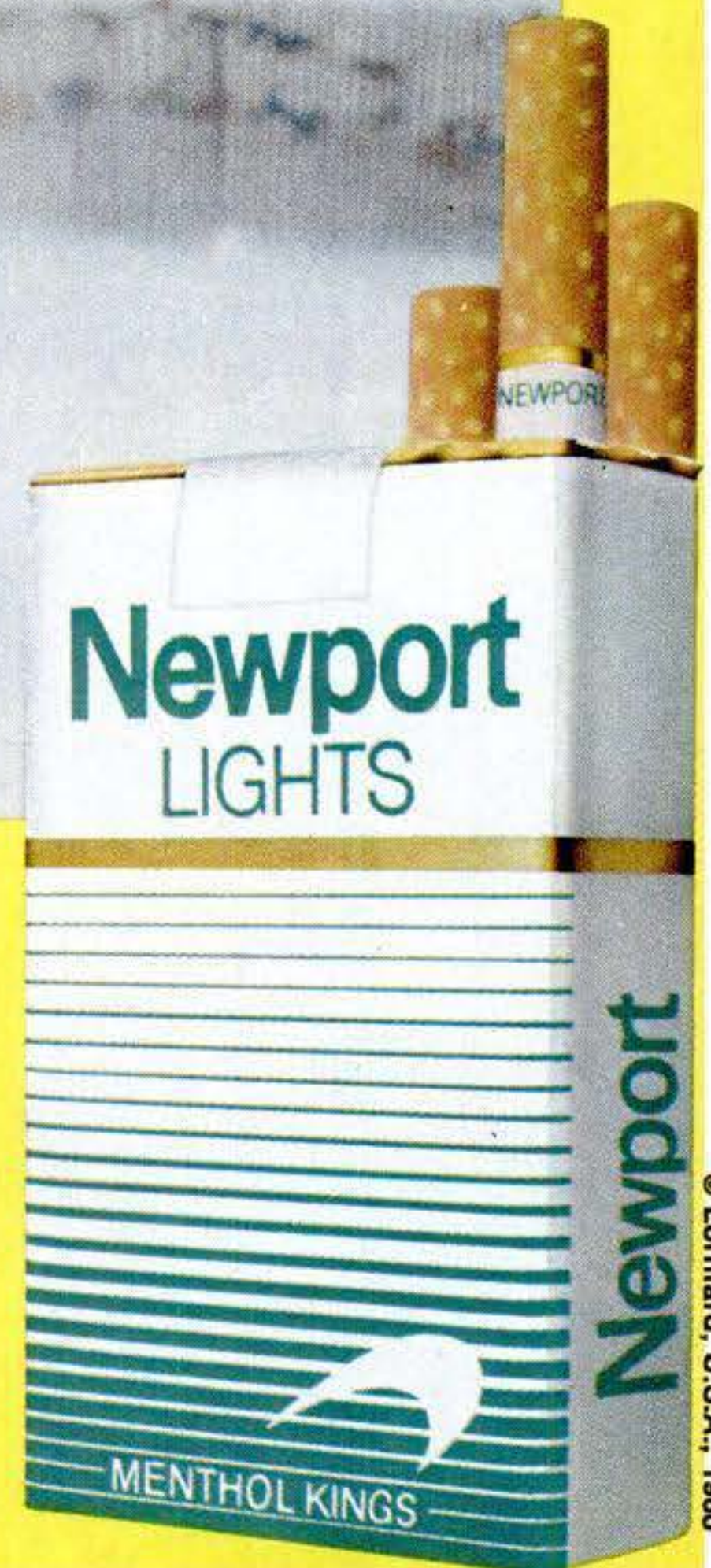

© Lorillard, U.S.A., 1980

Warning: The Surgeon General Has Determined
That Cigarette Smoking Is Dangerous to Your Health.

10 mg. "tar", 0.8 mg. nicotine av. per cigarette, FTC Report May 1978.

THE GUTS AND BOLTS OF A TOUGH CHEVY BLAZER.

A 4-wheel-drive Blazer is guts-and-bolts tough and practical. On or off the road, it's a people mover, trailer tower, cargo hauler. And it has the new 1980 Chevrolet Three-Year Perforation-From-Corrosion Limited Warranty. See your Chevrolet dealer for details. Ask about leasing, too.

| | | | | | | | | | |
|-------|-------|-------|-------|-------|-------|-------|-------|-------|-------|
| 84.1% | 87.9% | 87.5% | 93.6% | 93.9% | 96.1% | 96.7% | 99.2% | 99.9% | 99.9% |
| 69 | 70 | 71 | 72 | 73 | 74 | 75 | 76 | 77 | 78 |

A TOUGH RECORD TO BEAT. 94.8% of Chevy Light, Medium, Heavy-Duty trucks and commercial vans in the ten most recent years recorded were still on the job. (Based on R. L. Polk & Co. model year registrations through July 1, 1978. 1979 statistics not available at time of printing.)

Part-time 4WD now available with optional automatic transmission. Freewheeling front hubs help improve rolling efficiency over last year, when in 2WD. Manual transmission standard. Aluminum wheels available.

Staged, 2-barrel carburetor on standard 4.1 Liter (250 Cu. In.) Six. Not available in California. One barrel is used for normal operation. The second, larger barrel is activated for more power.

No extra suspension equipment required for off-road use with 4-wheel-drive Blazer. Front stabilizer bar, leaf springs and power steering are standard. Rear shocks are counter angled to help control brake/power hop. Power-assisted brake system is also standard and computer-matched to Blazer's Gross Vehicle Weight Rating.

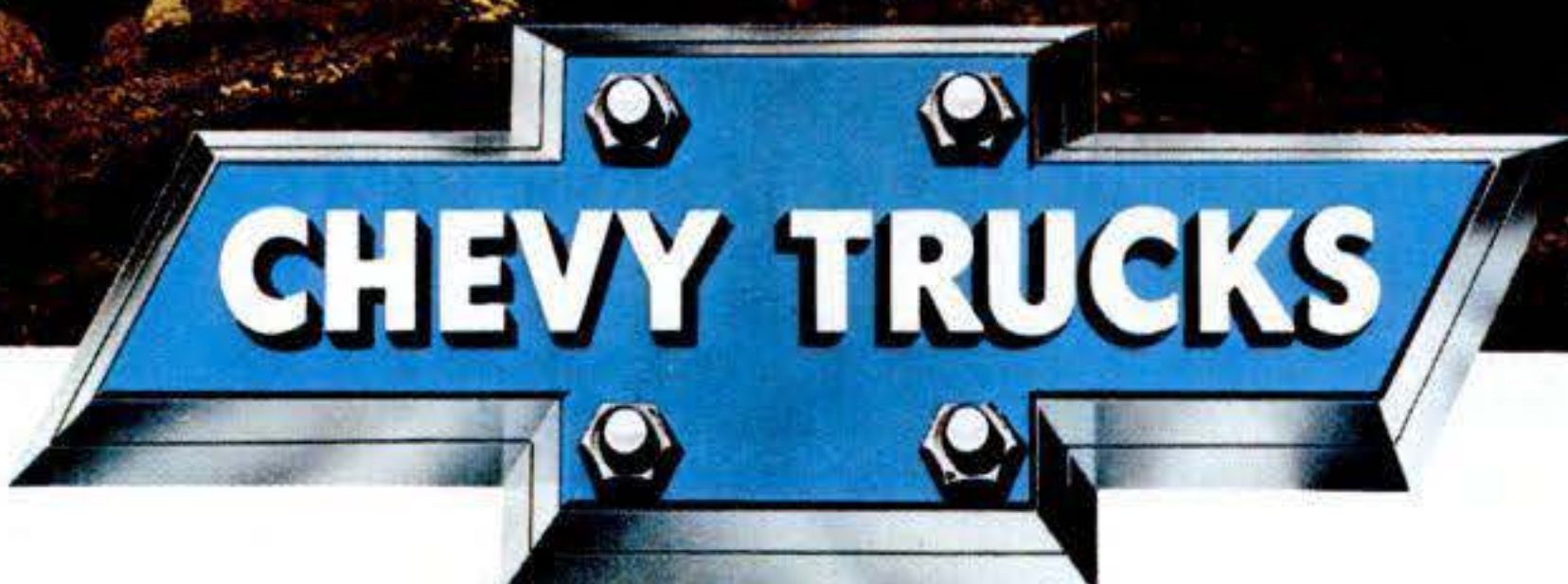
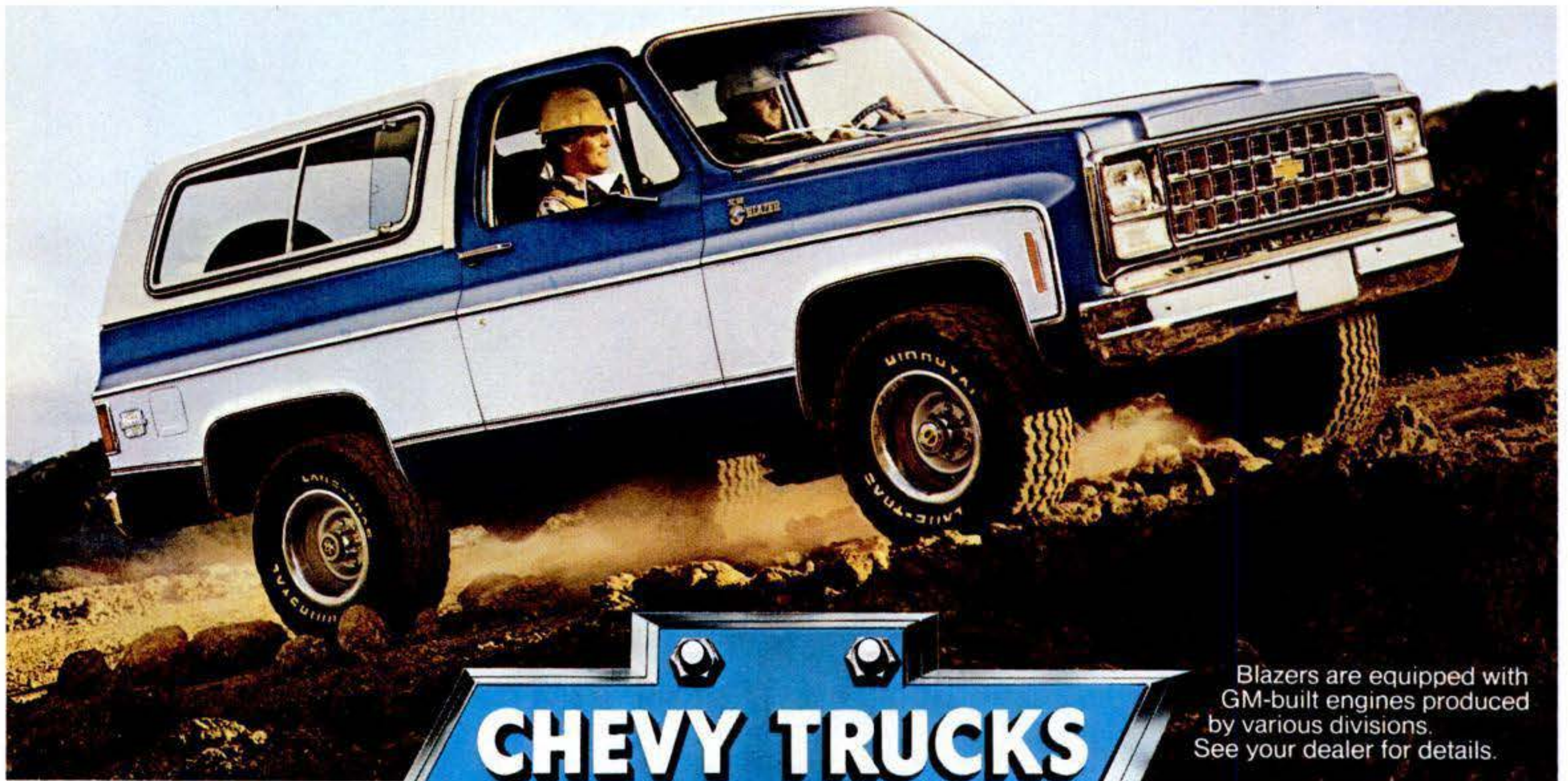
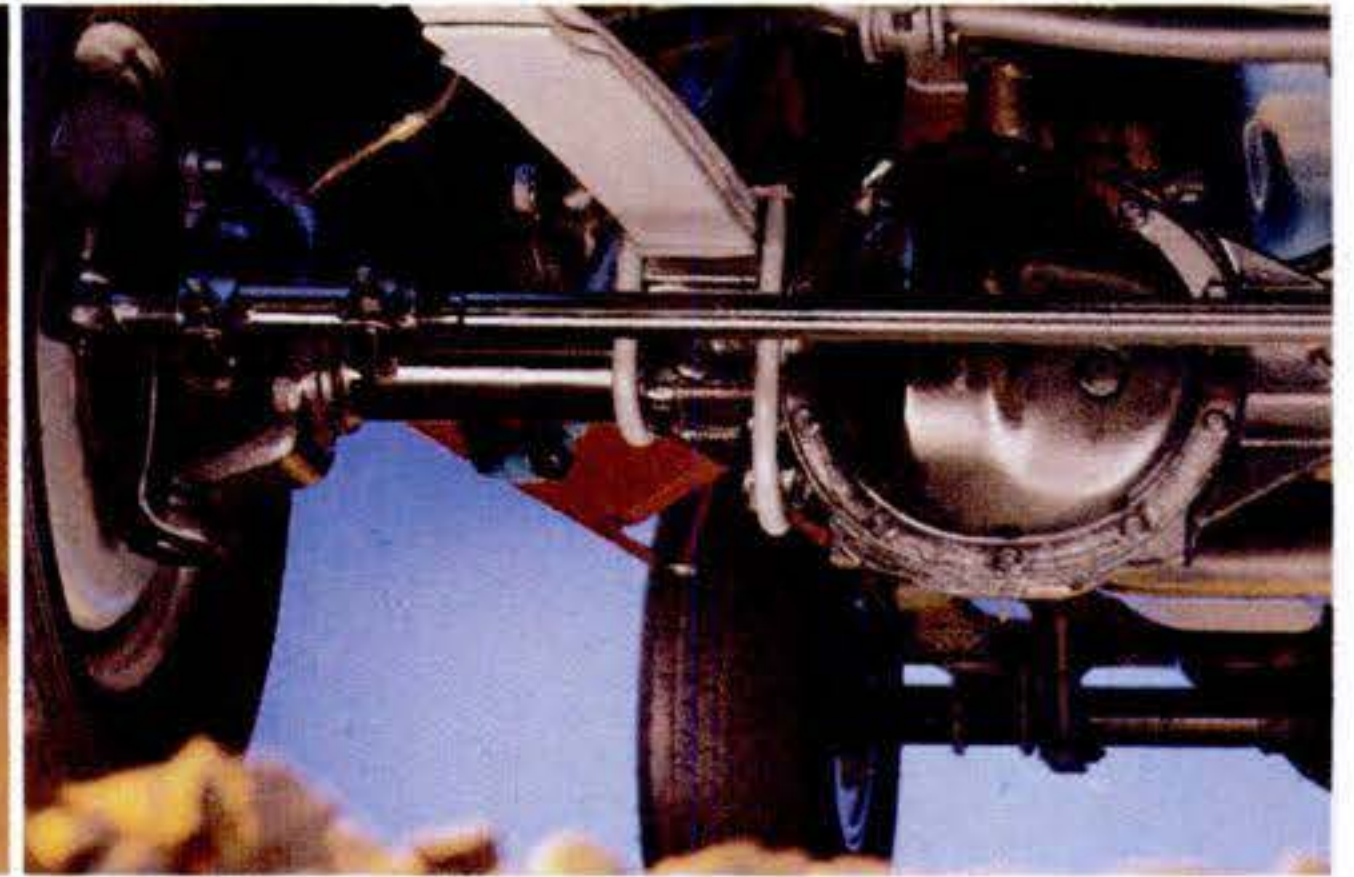

Blazers are equipped with GM-built engines produced by various divisions. See your dealer for details.

BUILT TO STAY TOUGH

Solar salts

— new chemical systems store the sun's heat

Clever ways to package phase-change salts may enhance solar heat storage

By RICHARD STEPLER

For more than 30 years, researchers have tried to tame phase-changing materials for use as energy-storage media. Why? A given quantity of these sticky, corrosive salts can absorb and release far more heat than tanks of water or bins of rock, the usual ways to store solar heat for use when the sun's not shining (see charts on next page).

Now, three new developments promise to make the use of such salts practical. All employ improved techniques to package the salt; and all involve improvements in the chemical makeup of the material.

- Sausage-shape packages of a patented, hydrated salt have been devel-

oped by the University of Delaware's Institute of Energy Conversion (top photo, page 50). The salt melts and freezes at 55 degrees F and would be used in air-conditioning systems to store cool air generated at night at off-peak rates. A variation of this system that would store solar heat during the day is also being developed by the Institute. The salt in this system would have a higher melting/freezing point.

- High-density polyurethane trays, filled with Glauber's salt and sealed using a spin-welding process (applying plastic to plastic under heat), are now being made by Valmont Industries (drawing below). The trays cost \$12.50 each, and Valmont estimates that an average home solar space-heating system with 300 square feet of collectors would require 120 trays, filling a box about two by 2½ by 10 feet.

- Also on the market is a six-foot-

long, 3½-inch-diameter polyethylene tube filled with calcium chloride hexahydrate, which changes phase at 81 degrees F. The thermal-storage compound was developed by Dow Chemical, with Dept. of Energy support. The Thermol 81 tubes are made by PSI, Inc., and cost \$29.90 each. PSI estimates that about 100 of the tubes would be needed in a typical residential solar space-heating system.

Past problems with phase-change materials have prevented their use. These have included:

- Supercooling, the tendency of the salts to go well below their freezing point before beginning to solidify.

- Encapsulation, the tendency of the material not to solidify completely. This reduces the salt's heat-storage capacity.

Dr. Paul Moses, Dow senior research chemist, explains that a key to the solution of these problems is adding a nucleator to the material to prevent supercooling. The nucleator starts the freezing process. "In addition," says Moses, "a vapor barrier is essential. If calcium chloride picks up water [it's hygroscopic], the salt loses its phase-changing ability rapidly."

Dow's energy-storage material is packaged in ultra-high-molecular-weight polyethylene tubes by PSI. The tube's end caps are thermally fused to permanently seal in the salt mixture. Thermol 81 rods carry a 10-year warranty.

Paul Popinchalk, an engineer with Valmont Industries, told me that Valmont has been working with Dr. Maria Telkes, a pioneer in phase-change materials. "We've changed the formulation of the Glauber's salt and the method of encapsulating it," he told me. "We're now replacing trays that

Continued

Solar heating with phase-change-salt heat storage

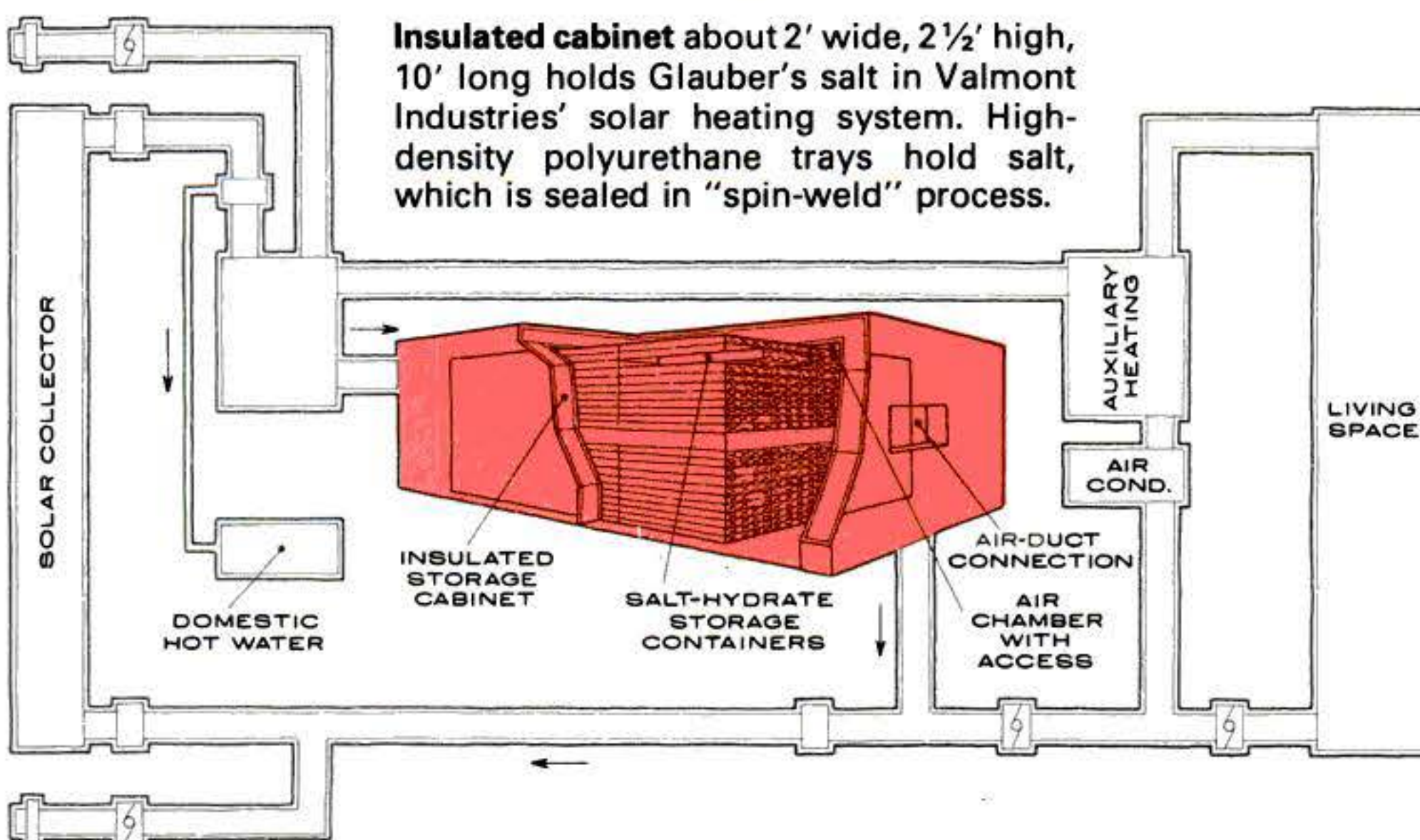



Salt sausages: University of Delaware borrowed technology from food-processing industry to develop low-cost polyester package.

Storage materials compared

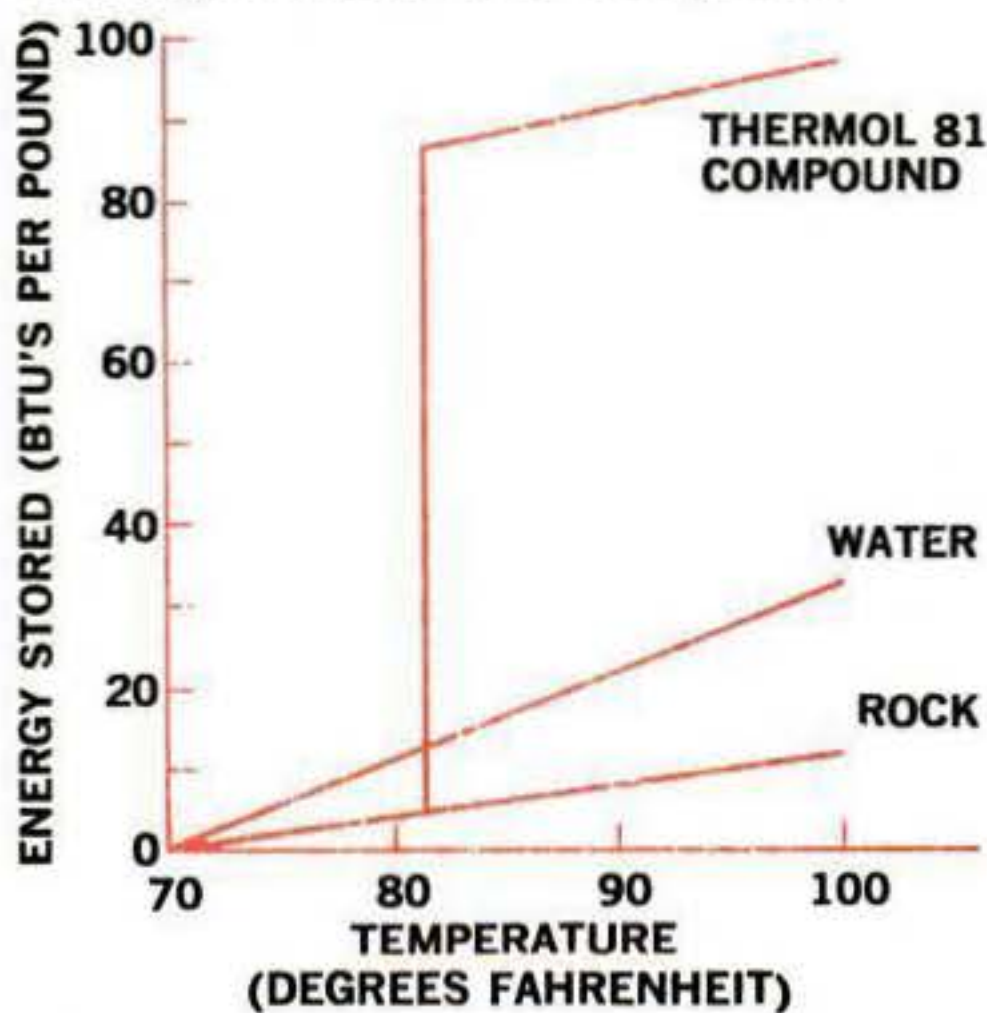

Needed to store 300,000 Btu:

| | Wt. (lb.) | Vol. (ft ³) | Vol. (gal.) |
|-----------------|-----------|-------------------------|-------------|
| Rocks | 37,000 | 480 | 3600 |
| Water | 12,000 | 380 | 2900 |
| Thermol 81 rods | 3700 | 78 | 600 |

didn't work in about 50 systems already installed." Valmont offers a five-year limited warranty.

Dr. Allen Barnett, director of the University of Delaware's Institute of Energy Conversion, says that solving the packaging problem is the key to making the system economical. Working with the Du Pont Co., and adapting food-packaging technology, the Institute developed a low-cost, sausage-shape package of multilayered polyester film to contain its patented mixture of hydrated salts. The reliability and performance of Delaware's system are now being studied. PS

FOR MORE INFORMATION

Institute of Energy Conversion, University of Delaware, One Pike Creek Ctr., Wilmington DE 19808; PSI Energy Storage Div., 1533 Fen Park Dr., Fenton MO 63026; Valmont Energy Systems, division of Valmont Industries, Valley NE 68064.



Phase-change salt is sealed inside PSI's 6'-long, 3½"-dia. polyethylene tubes (photo). Drawing (right) shows typical storage container for an average home. Drawings below show how tubes could be used in passive/active solar applications.

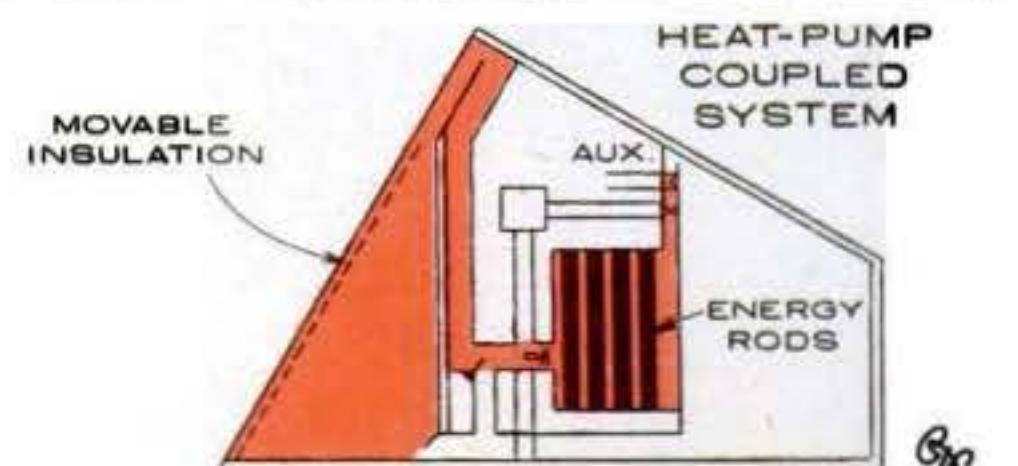
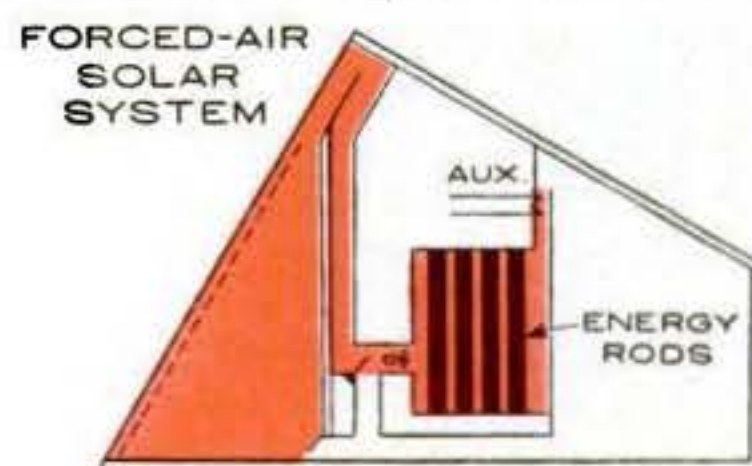
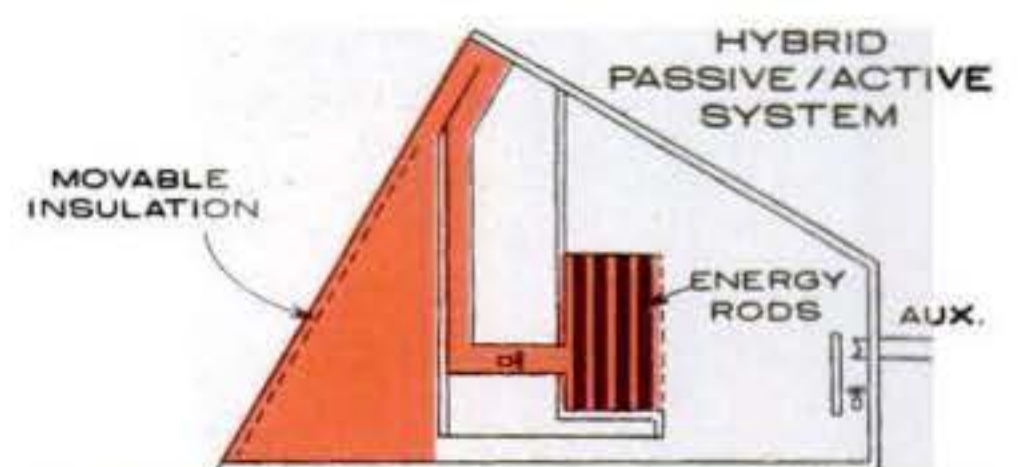
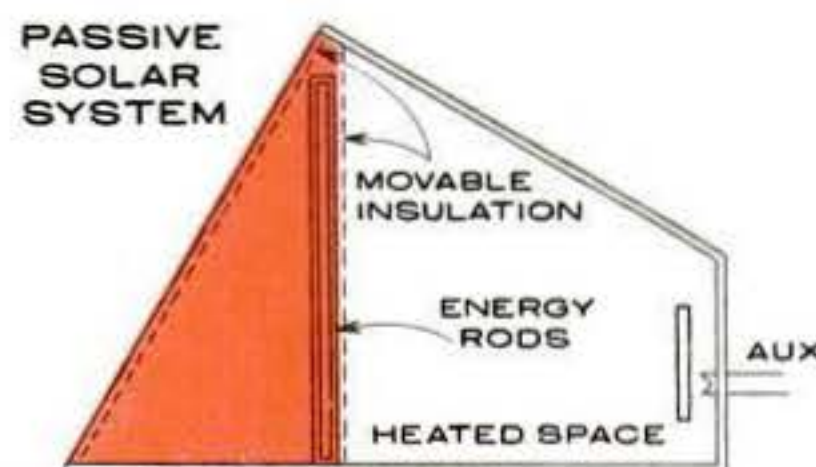
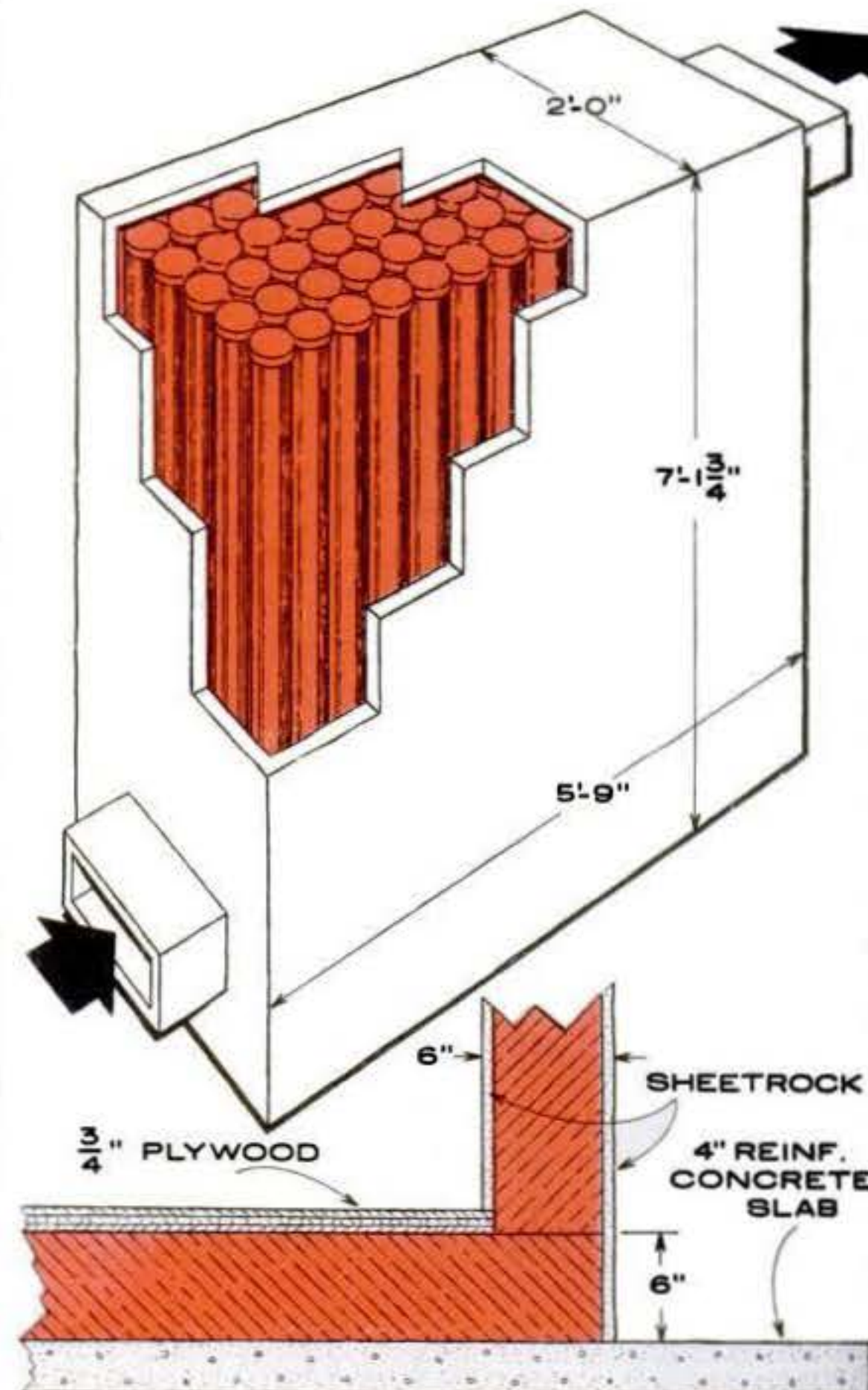

NATURAL WOOD SHINGLES DIDN'T STAND UP TO MOTHER NATURE, SO NORCHESTER DECIDED TO REPLACE THEM WITH TIMBERLINE.

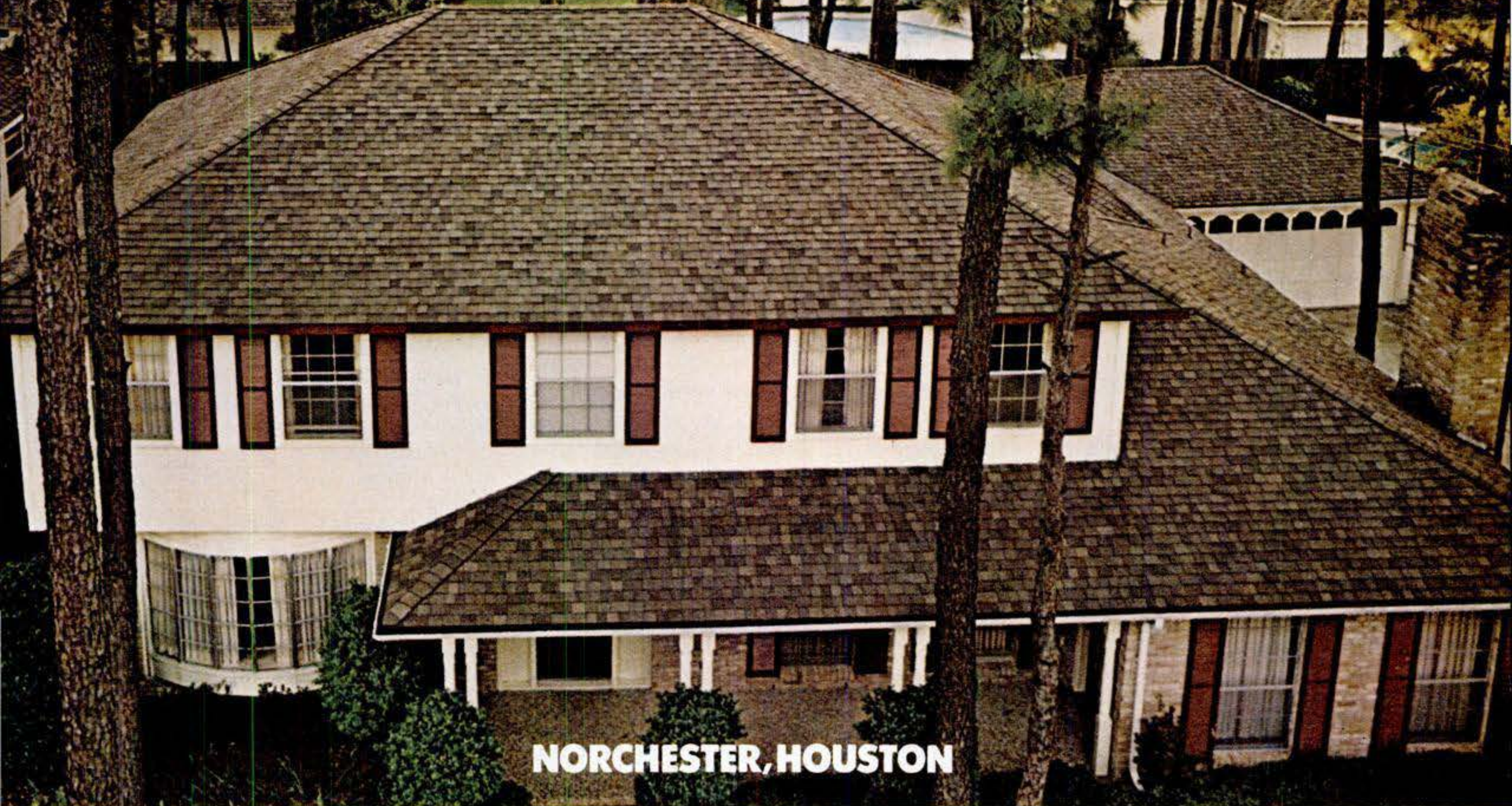

NORCHESTER, HOUSTON

Mother Nature is quite capable of delivering weather no shingle can stand up to. So it comes as no surprise that a severe storm destroyed the original wooden shingles used to roof a Houston neighborhood.

While we're not guaranteeing we'll stand up to this horrendous weather any better than wood, we do think they've chosen the right brand of asphalt shingles to reroof their homes. Timberline[®], the number one selling asphalt shingles of their kind.

They bear an uncanny resemblance to wood. But their real beauty lies in their superb strength and durability.* Timberline shingles have a ceramic baked, granular surface that resists fire and blocks the harmful ultra violet rays that eat away even the best of roofs. They're also composed of the highest quality, scientifically refined asphalt. So they repel water.

And Timberline shingles have a self-sealing agent that works with the sun to form a wind resistant one piece roof. So your investment won't blow away.

To find out more about Timberline shingles, get in touch with your nearest GAF dealer through the Yellow Pages. Or call toll free 800-223-0344, in New York call 800-522-5250.

If you put anything other than Timberline on your roof, you may be wasting your time. Not to mention your money.

GAF[®] TIMBERLINE[®]
ASPHALT ROOFING
On top of the industry.

*See GAF "Limited Warranty Asphalt Shingles" for specific details of coverage on Timberline. This warranty is available free by writing to the GAF Corporation, Building Products, Dept. T979, Box 1121, Radio City Station, New York, 10011.

RECREATION ROUNDUP

By HERBERT SHULDINER

RV fuel costs

Gasoline costs have rocked recreational-vehicle owners harder than anyone else. The reason is obvious. The bigger RV's burn more fuel per mile traveled than other pleasure vehicles (although the fuel burned by all motor homes in the U.S. is negligible compared to our total gasoline consumption).

So it's amazing to hear a manufacturer announce that he's going to roll back the fuel cost per mile of his motor homes to what they were 15 years ago. And it could just happen that way by year's end if John K. Hanson, founder of Winnebago, can complete the total revamping of the company's 22½-foot Minnie Winnie motor home, as he has promised.

Hanson told me recently that the 1981 model he plans to build will be 4000 pounds lighter than the 1980 model now on sale. And with the diesel engine he hopes to have in the RV, it will get 22–24 mpg, "according to computer studies Winnebago has performed."

Besides shedding two tons, Hanson says, the vehicle will be lower and sleeker, with a much lower coefficient of drag. Because the vehicle will weigh only 6500 pounds, it will have single rear wheels rather than the duals now used. Much less material will be used in the '81 mini motor home to help achieve the total weight reduction—without sacrificing structural integrity or crashworthiness, he claims.

In addition, the RV will be built on a new front-drive chassis, which Hanson declined to identify as we went to press. There are no domestic front-drive vans currently, nor is one due from Detroit this fall. So it will be interesting to see where Winnebago can obtain its chassis. Could it be planning to build its own with GM's front-drive X-body components?

Less motor-home power

What is certain is that there will be a lot less power in the motor home with a diesel engine. "I couldn't care less if we don't have the power," Hanson says. "I don't think we need it."

Does the arithmetic add up? Will the new motor home actually cost about the same to operate per fuel mile as motor homes did 15 years ago? Gas cost about 30 to 35 cents a gallon 15 years ago, and motor homes got about six to seven miles per gallon then. That came to a little under six cents a mile.

Diesel fuel will probably cost about \$1 a gallon this fall. Even at 22 mpg, the fuel costs for the new motor home would be less than a nickel a mile. So it would seem that Hanson can make good on his boast if

he can deliver the new vehicle on schedule—and if it performs as the computer says it will.

If Winnebago can't succeed by this fall, I think it won't take much longer than another model year to produce such a vehicle. The technology certainly exists. It's a matter of getting the whole package together at a price that's acceptable to the RV public. One complication is that RV sales have shrunk so drastically. That makes the market less attractive to the chassis makers in Detroit—especially to financially hard-pressed Dodge, which has traditionally supplied the majority of motor-home chassis.

Gas consumption while towing

How much extra gas does your car burn when you're towing a trailer? The Coleman Co. recently conducted some tests to get the answer to that question as it affects lightweight camping trailers. The results seem to indicate that bigger engines may actually be more economical for trailer towing than small power plants.

In towing four Coleman trailers—Ligonier (1050 pounds), Gettysburg (1310 pounds), Valley Forge (1310 pounds), and

Brandywine (1495 pounds)—over a hilly road in southwestern Pennsylvania, extra fuel consumption ranged from 1.29 to 1.38 gallons per 100 miles traveled with the four-cylinder-powered car. Interestingly, added fuel consumption was lower with the six-cylinder car—0.77 to 0.96 gallons per 100 miles.

The tests were run by Dr. Ronald M. Weiers, associate professor of marketing at Indiana University of Pennsylvania. He used a 1980 four-cylinder Chevrolet Citation and a six-cylinder Ford Fairmont—both with automatic transmission, power brakes, and power steering.

The car-trailer combinations were accelerated to 55 mph and kept at that speed for a round trip of 28.7 miles on a limited-access highway—except where traffic density caused the driver to go slower.

Coleman campers are relatively light and have a low, clean profile. It would be informative to have similar controlled tests with standard, heavier trailers. This would help consumers get a better fix on what the real operating costs are for trailer towing.

RV makers shrinking

In early 1979—before the upheaval in Iran—there were 207 manufacturers of RV's, according to the Recreational Vehicle Industry Assn. By year's end, some 52 of the manufacturers had folded, but, surprisingly, 18 new ones took their place. The net loss was 34 (16.4 percent). I'm surprised that the bloodletting was not greater. Last year was one of the worst ever for RV sales. The RVIA says sales dipped 49 percent in 1979. What's the outlook for this year? RVIA is predicting a four percent increase in shipments in 1980.



Solar-heated travel trailer

The Spacetrekker 610 is an English-built travel trailer with a solar-assisted water and space heating system. A one-square-meter flat collector with propylene glycol heat-transfer fluid is atop the expandable roof and can be elevated to a 45-degree angle. When oriented in a southerly direc-

tion, the collector heats water to 55 degrees C on a sunny day. If the water is colder than that, a gas-fired furnace takes over to supply heat. It's built by GX Caravans, Ltd., London Rd., Bagshot, Surrey, England. The trailer sleeps seven persons—two in the "penthouse" bunk. [E]

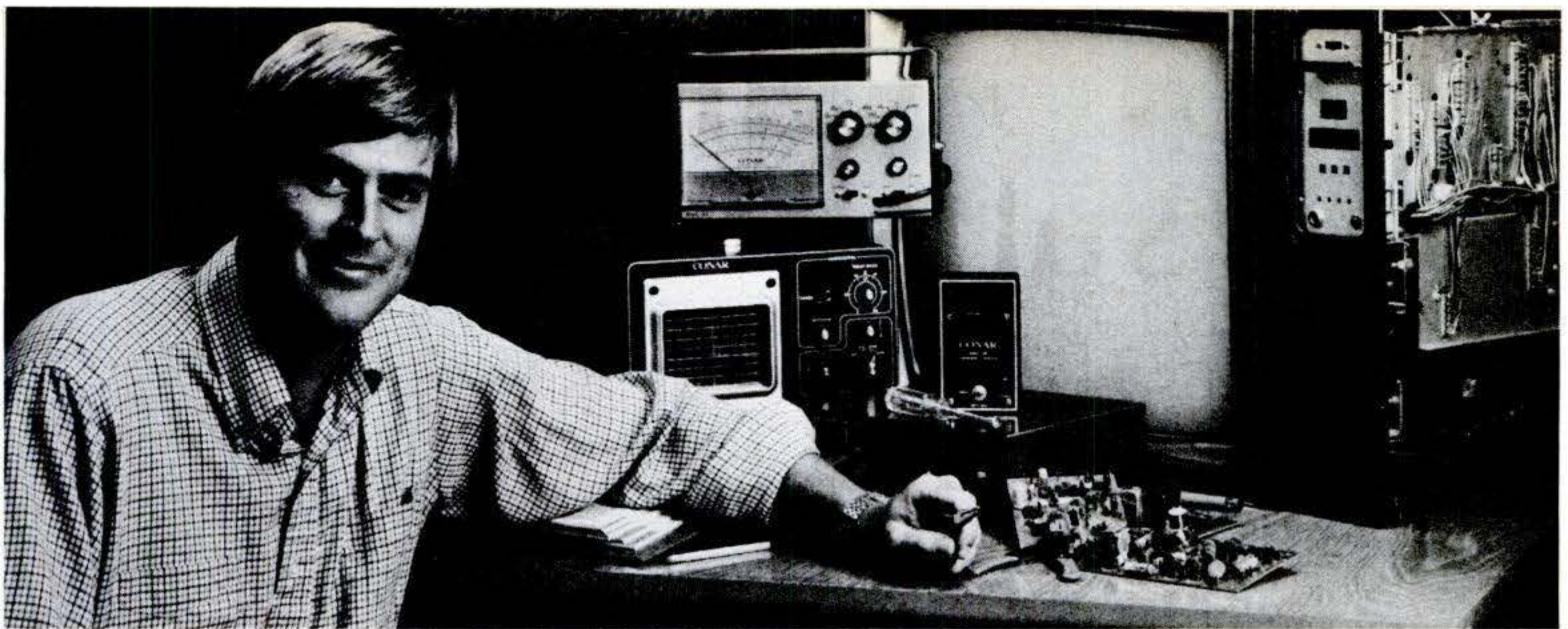

Wouldn't you like to have a new skill you could call your own? Then learn TV and audio servicing with at-home training from NRI.

You can learn to service and repair TV, stereos, electronic musical instruments and amplifiers, car and portable radios, record and tape decks, the new video disc and tape players, almost any kind of electronic home entertainment equipment on the market. And as you take NRI's Master Course, you build your own 25" (diagonal) color TV with built-in computer programming that lets you preset a whole evening's viewing. You also build a solid-state stereo receiver with speakers and professional quality test instruments you keep and use.

Designed-for-learning Equipment

The computerized TV, stereo, and test equipment you build are not hobby kits or preassembled commercial units with retrofitted lessons. They are designed by NRI engineers and instructors to give you valuable experience as you build them, reinforce theory with practical demonstrations, and end up as fully operable, high-performance units you'll be proud to have. And only NRI gives you "power-on" training...you introduce and correct problems in live circuits as you learn.

Build Advanced Technology TV

The NRI TV you build features the latest advances in video science. Its com-



puterized tuner lets you change channels at the touch of a button, preset up to eight hours, programming and key lock it in to control children's viewing. It includes automatic tint and chroma controls, automatic degaussing, and automatic fine tuning...oversized speaker, built-in digital clock, 100% solid-state chassis, modular plug-in circuit boards, and the latest development in picture tubes with 100° tri-potential focus in-line gun. And console cabinet is included at no extra charge.

Other kits you build include the NRI stereo, 5" triggered-sweep oscilloscope, digital frequency counter, 10-display TV pattern generator, transistorized volt-ohm meter, and the NRI Discovery Lab® for performing additional experiments and proving theory.

Learn at Home in Your Spare Time

With NRI at-home training, you don't have to worry about night classes or interfering with your job. You work at your own pace with NRI "bite-size" lessons. And if you have questions or problems, your NRI instructor is always available for consultation and help. You control your progress, take a leisurely pace or go as fast as you like.

Free Catalog... No Salesman Will Call

NRI does not employ salesmen. You make your own decision without pressure, with all the facts in front of you in our free, full-color catalog. It describes the course in full, showing all equipment, lesson outlines, and specifics of NRI training. It also shows other exciting courses like Microcomputers and Microprocessors, the big world of Complete Communications, and more. Mail the postage-paid card today for your copy. And see how you can make the most of your talent. If card has been removed, write to:



NRI SCHOOLS
McGraw-Hill Continuing
Education Center
3939 Wisconsin Ave.
Washington, D.C. 20016

Discover Camel Lights satisfaction.

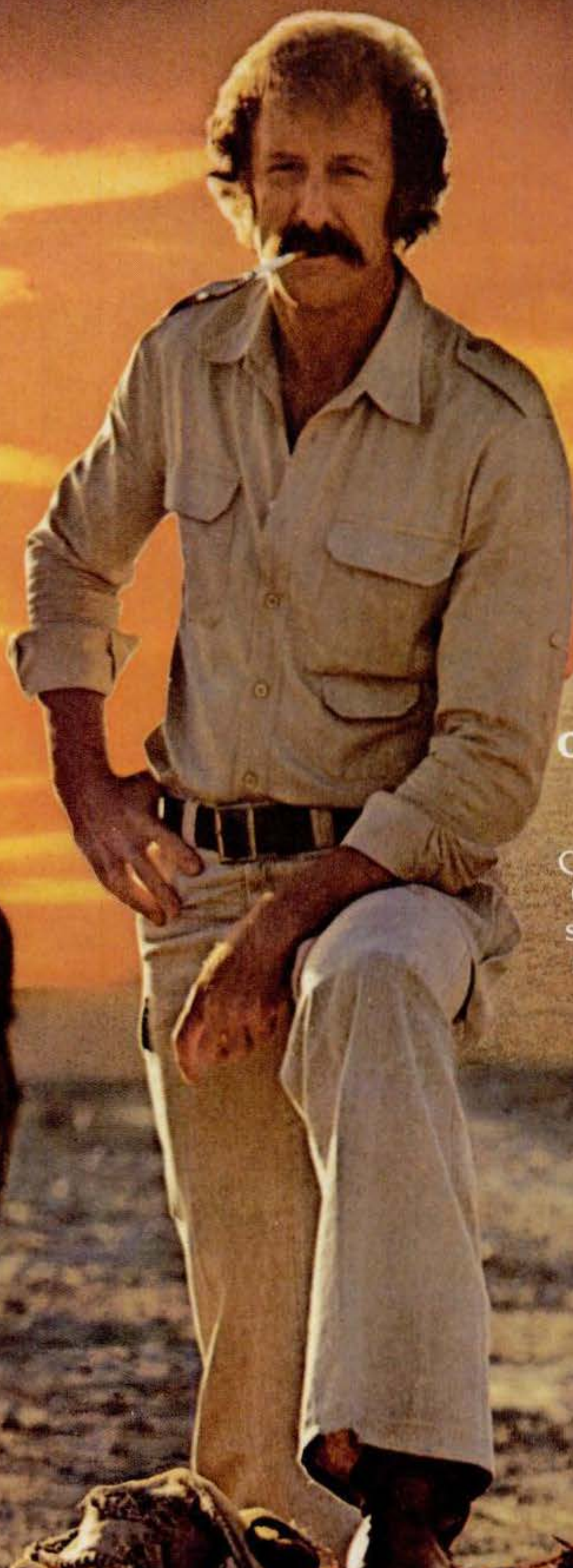

The Camel World of satisfaction comes to low tar smoking.

This is where it all started. Camel quality, now in a rich tasting Camel blend for smooth, low tar smoking. Camel Lights brings the solution to taste in low tar.



Warning: The Surgeon General Has Determined That Cigarette Smoking Is Dangerous to Your Health.

LIGHTS: 10 mg. "tar", 0.8 mg. nicotine, LIGHTS 100's: 13 mg. "tar", 1.0 mg. nicotine, av. per cigarette by FTC method.

LOOK AND LISTEN

By JOHN FREE



Voice-controlled hi-fi

At a recent Toshiba press conference I noticed a stack of mini-hi-fi components [PS, Jan.] with a microphone attached. But the mike, I learned, wasn't plugged in to record music. Instead, it lets you store 15 verbal commands in a microcomputer memory. After that, the hi-fi system responds only to your voice, enabling you to perform 19 functions—operating a cassette deck orally, controlling volume, or selecting tuner channels, for example.

Voice-actuated electronics, familiar to computer hobbyists, is expected to become commonplace in the 1980's. Toshiba and other firms have also shown voice-actuated TV prototypes. Toshiba's system may put a question mark on an LED display if it doesn't understand you. Or a voice generated by the system may answer with "repeat" and then "okay" when your diction is recognizable. Toshiba has no definite marketing plans.

High-definition TV

While voice-operated TV's may be avail-

able in a few years, high-definition TV, under study by the Society of Motion Picture and Television Engineers, is further off. TV expert Donald Fink recently outlined the conclusions of an SMPTE panel studying how color-TV fidelity should be improved. Detailed recommendations are slated for the society journal. Highlights:

- Data on how viewers react to superior high-definition (HD) TV is very meager. Public exposure in theaters may be needed prior to home introductions.

- A standard of comparison, for HD TV standards, should be the superior quality of original 35-mm movie releases. A wide-screen aspect ratio, such as 2:1, is preferable to today's 4:3 ratio.

- Some 1100–1500 scanning lines, compared to 525 in U.S. broadcasts, should be established. A signal bandwidth of about 25 MHz (enough for four TV channels today) is needed.

- Color and brightness (luminance) signals should not be combined as they are now for compatibility.

- A "junior" version of an HD TV system, with excellent pictures, can be achieved today on sets that use all of the station's signal. Color sets now reject about half the available signal. New techniques such as comb filters ["Hi-fi Color-TV Pictures," PS, Aug. '78], Fink noted, are starting to improve picture fidelity.

- Getting HD TV into homes is feasible with direct satellite-to-home signals [see story on satellite TV in this issue]. In Tokyo, a satellite-to-Earth 1100-line HD TV system has been demonstrated with a five-foot receiving dish. Fiber-optic cable-TV setups might also be used.

As long as experts are revamping color-TV standards, University of Illinois psychology professor Jozef Cohen and colleague Thomas Friden of the University of New Mexico believe the National Television Standards Committee (NTSC) technique of encoding color pictures should be changed. "Somewhere, somehow, the NTSC has confused brightness (or luminance) with achrominance (or whiteness). These are very different things," Cohen writes. His and Friden's papers on the subject are based on a computer study and historical review of color-perception theory. Cohen believes some of the subtle technical problems with color-TV pictures stem from erroneous signal encoding that starts at studio TV cameras.

Sonic holography

Bob Carver, demonstrating his new C4000 preamp for me, cleaned a disc and put it on a turntable. He began playing a musical in stereo. "Now listen for the off-stage

voice," he said, pushing a C4000 button labeled SONIC HOLOGRAM GENERATOR. As he did so, the space between the stereo speakers in the hotel suite seemed to expand dramatically. The 3D expansion of audio space almost seemed to wrap around the room—a far greater change in listening realism than suddenly switching from monophonic to stereo. It was easy, I found, to pinpoint the apparent source of "Fiddler on the Roof" offstage lines.

But while the 4000's circuits do a remarkable job of adding realism to sound from stereo discs, there's only a very narrow location in front of the speakers (one person wide) where the sonic "holography" effect is clearly audible. The \$867 preamp, with enough push buttons for an F-111B electronic-countermeasures panel, has special noise-reduction circuits, and time-delay circuits that further alter the apparent size of your listening room. Record companies may market discs encoded by Carver's sonic-holography technique that could be played back without the special preamp circuit.

Quick looks

- IBM has joined forces with MCA and Japan's Pioneer to produce and market optical video-disc players. GM now has two-thirds of 10,000 players it ordered.

- Latest entry to the video tape and disc software field is Warner Communications' WCI Home Video Inc. For 1980, it's planning 55 releases.

- Home-computer firms must redesign their products to meet new FCC standards. Many machines radiate interference on lower TV channels and FM.

- BASF will call its new VCR a Linear Video Recorder (LVR). Planned for marketing soon, this deck moves tape at high speed over a stationary head.

- Two-way cable-TV operations are growing as Warner Cable Corp. and American Express expand the Columbus, Ohio, Qube system into Houston, Cincinnati, Pittsburgh, and elsewhere. Shop-at-home systems based on credit cards may be set up.

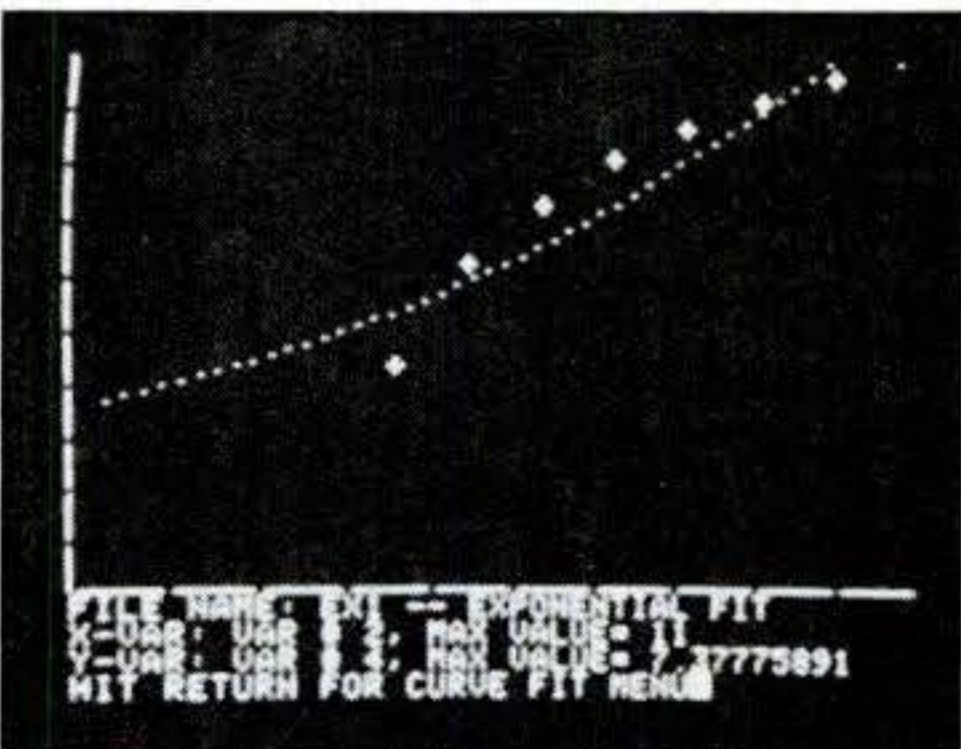

Curve plotter

Tired of regular TV fare? Apple II computer owners, used to creating their own computerized TV images, can now tackle simple or complex statistics problems with the Stat Pac. This new computer-disk program from Creative Discount Software (256 S. Robertson, Suite 2156, Beverly Hills, Calif. 90211) fits curves to data (above), stores data, and includes key statistics functions. 

NEW IDEAS FROM THE INVENTORS

ILLUSTRATIONS BY DANA RASMUSSEN

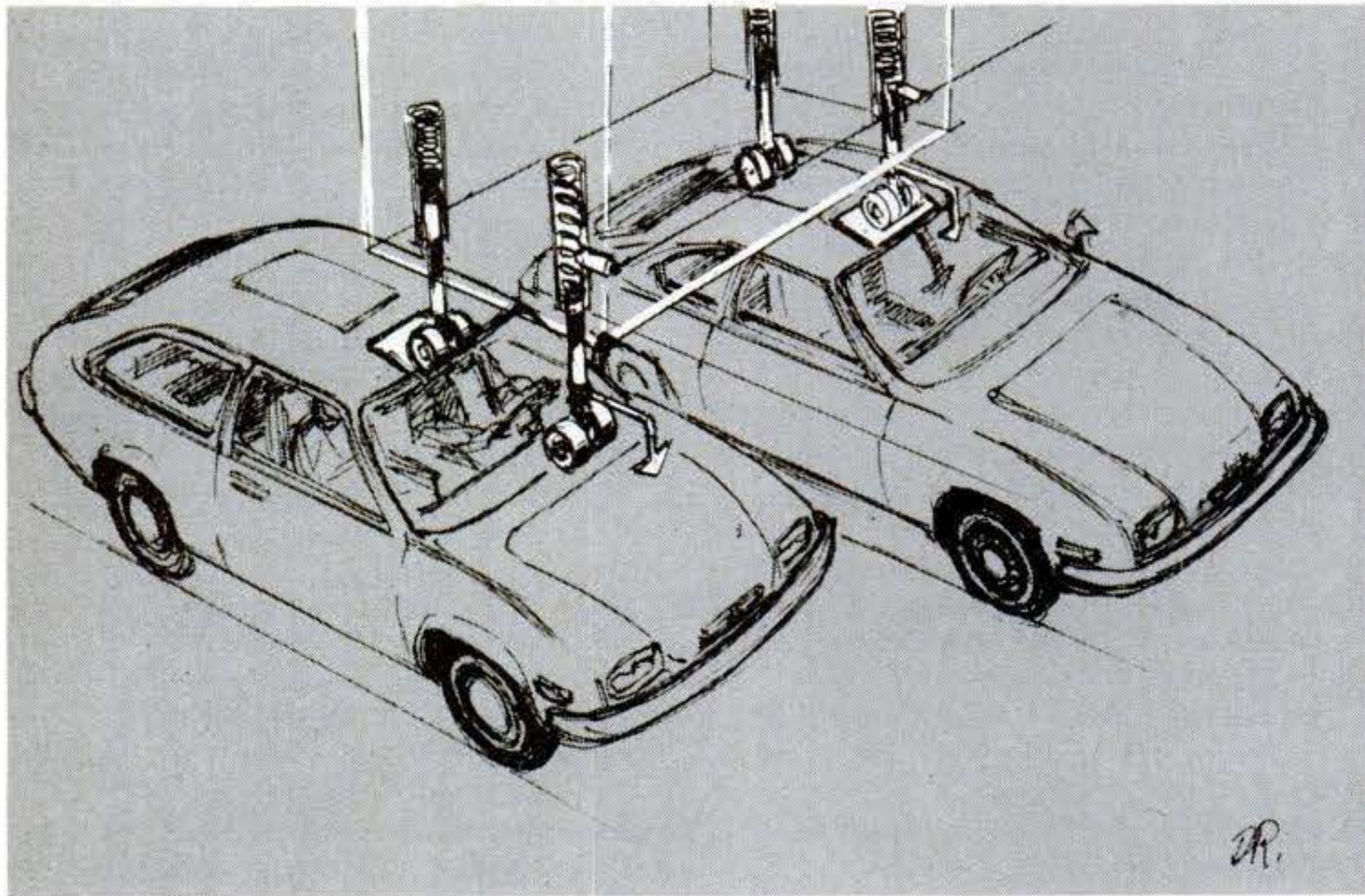

Overhead garage contacts recharge electric car

Installed in your own garage (or in selected spaces in a public garage), this overhead electric system would automatically recharge your battery-powered car when you parked. Spring-tensioned let-down contacts would ride up as you parked (fol-

lowing a positioning arrow), closing the charging circuit and coming to rest on hot and grounded car-top plates. A manual switch or automatic circuit breaker would start the juice flowing or cut it off in case of a water-caused short.

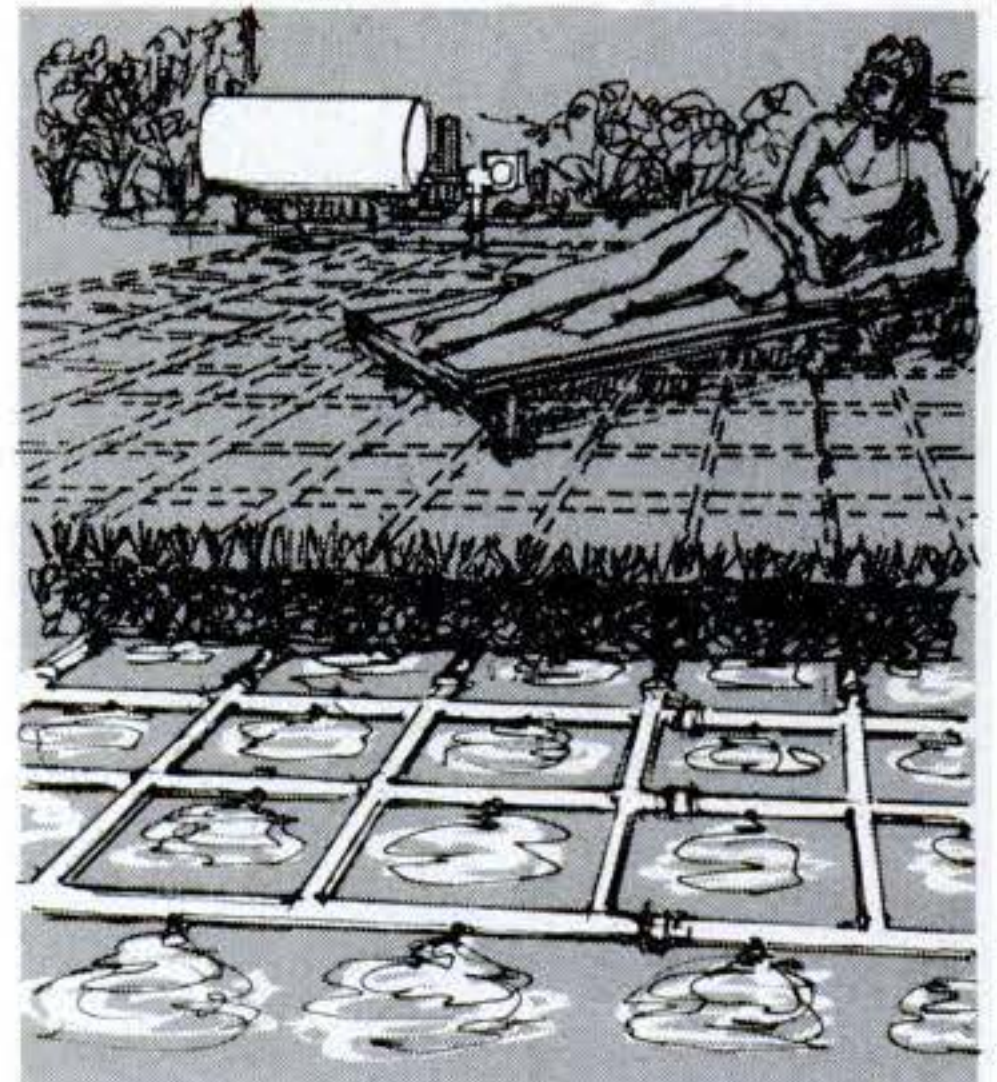

Simple, effective irrigation

This underground irrigation system would use less water to keep your lawn green, and omit the misdirected dousings of conventional sprinkler systems. Formed from two sheets of plastic sealed to make a grid of interconnecting lines, it would release water by gravity feed. Any homeowner could easily and cheaply install and customize the system to fit his individual needs.

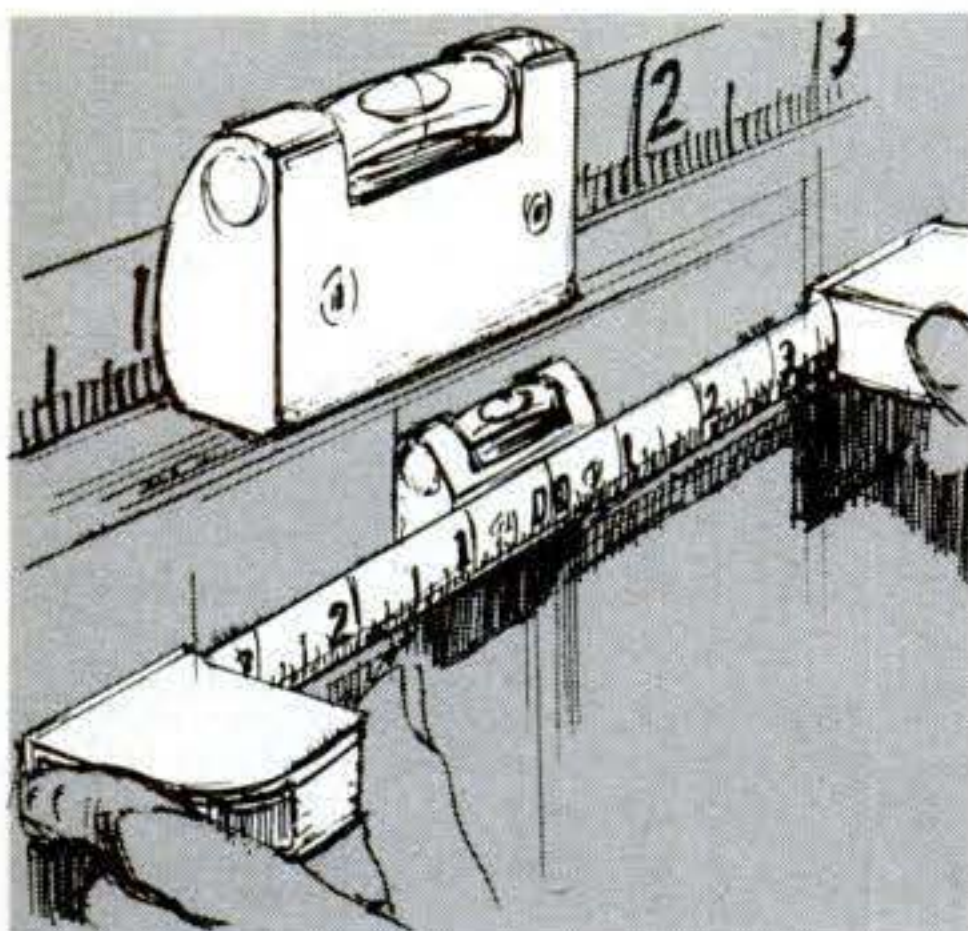

Measuring tapes hold level

Extending both ways from a centered mount containing a bubble level, these coiled-steel measuring tapes might make it easier to mark precise distances (for mounting holes, say) by holding a true level. The mounting block would have a concave shape to mate the tapes' convex face; with the block flat on a surface, the ruler would be free-standing and level.

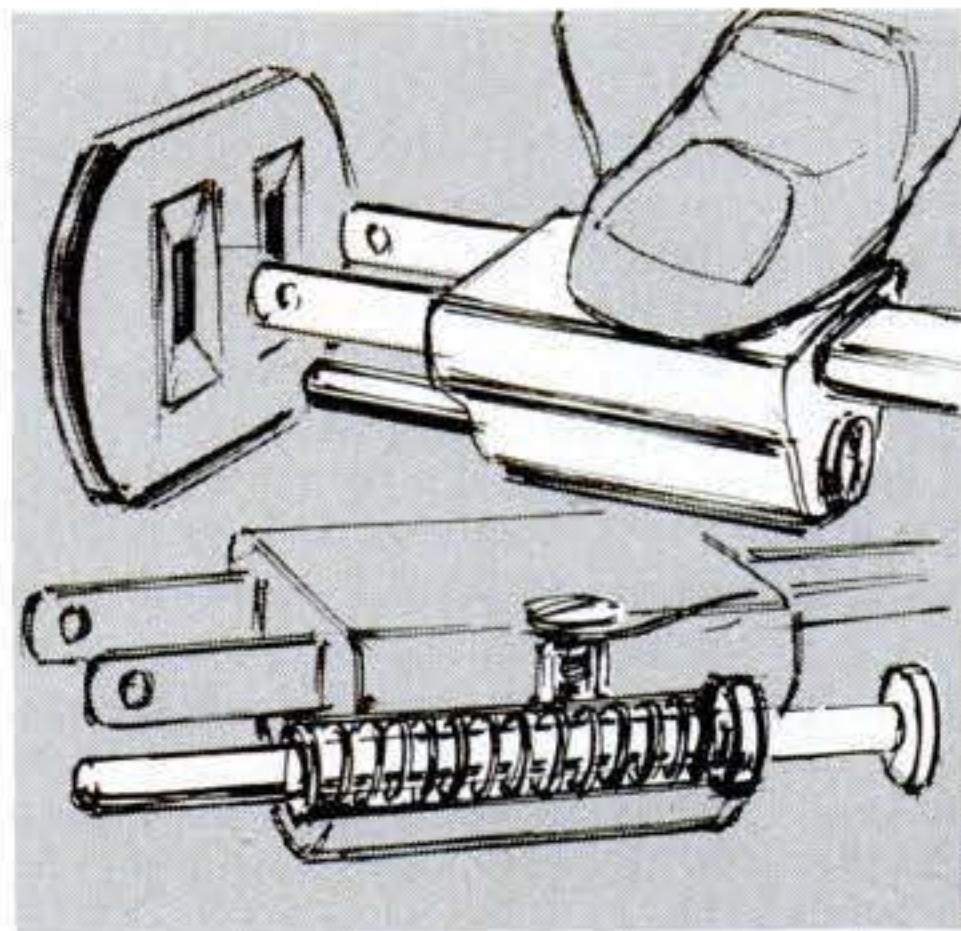

Third prong retracts on plug

The grounding prong on this electrical plug would be retractable, making it convertible for use in a two-prong receptacle. The spring-loaded prong would slide—and lock in an inactive position—inside a conductive tube connected to the power cord's third wire. For use in a three-prong outlet, the prong would latch in its forward, active position.

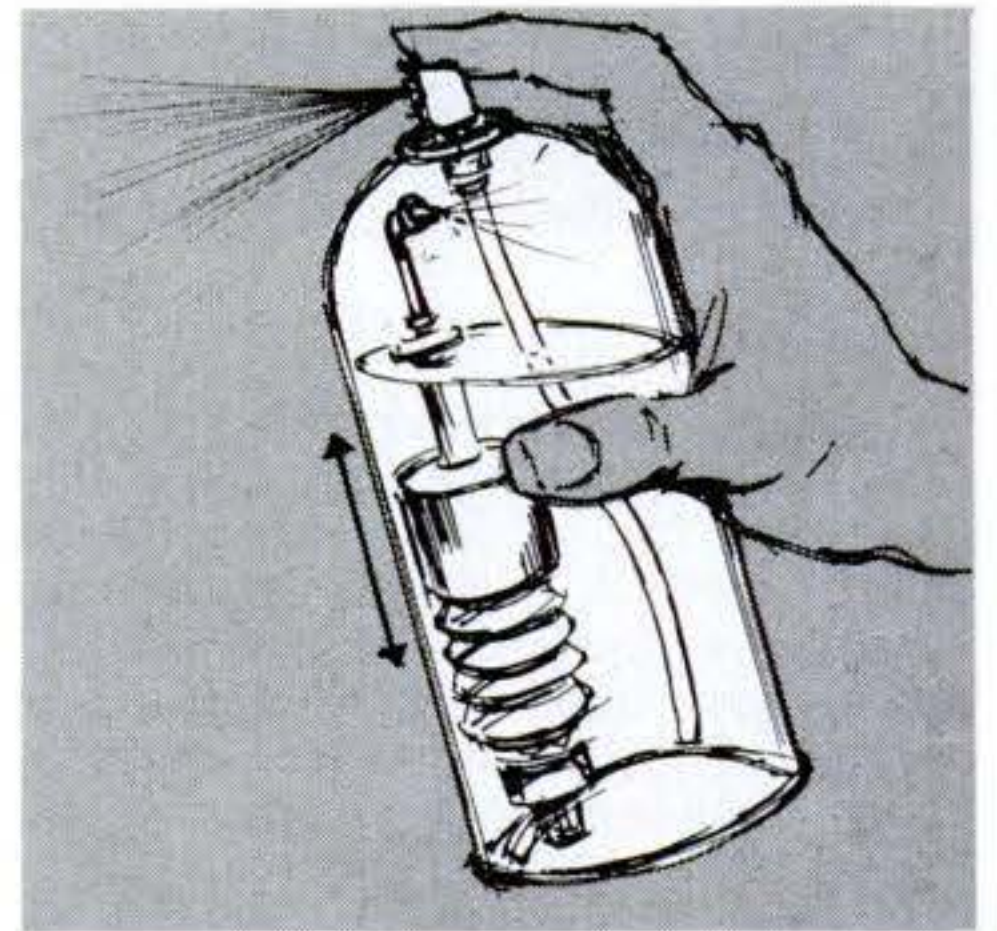

Shaking charges aerosol spray

A compact air compressor attached to—or built into—a liquid container would spray the container's contents in the same way as environmentally questionable aerosols but would use only air as a propellant. Shaking the can would cause a weighted bellows to pull air through a valve and force it into a reservoir that would store enough compressed air for one use.

The following patents have been issued on these inventions: **Electric-car charger**—No. 4,158,802 to William R. Rose, Scarsdale, N.Y.; **Ruler-level**—No. 4,070,764 to Daniel P. Rohlinger, Pewaukee, Wis.; **Convertible plug**—No. 4,078,848 to Donald A. Blairsdale, Pinole, Calif.; **Buried lawn sprinkler**—No. 4,065,926 to Edison R. Brandt, Boca Raton, Fla.; **Air-powered**

spray container—No. 4,147,284 to John V. Mizzi, Goldens Bridge, N.Y. Copies of patents may be ordered, by number, from the Commissioner of Patents and Trademarks, Washington, D.C. 20231, at 50 cents each. To write to an inventor, if address above is insufficient, address him by name and patent number in care of the Commissioner.

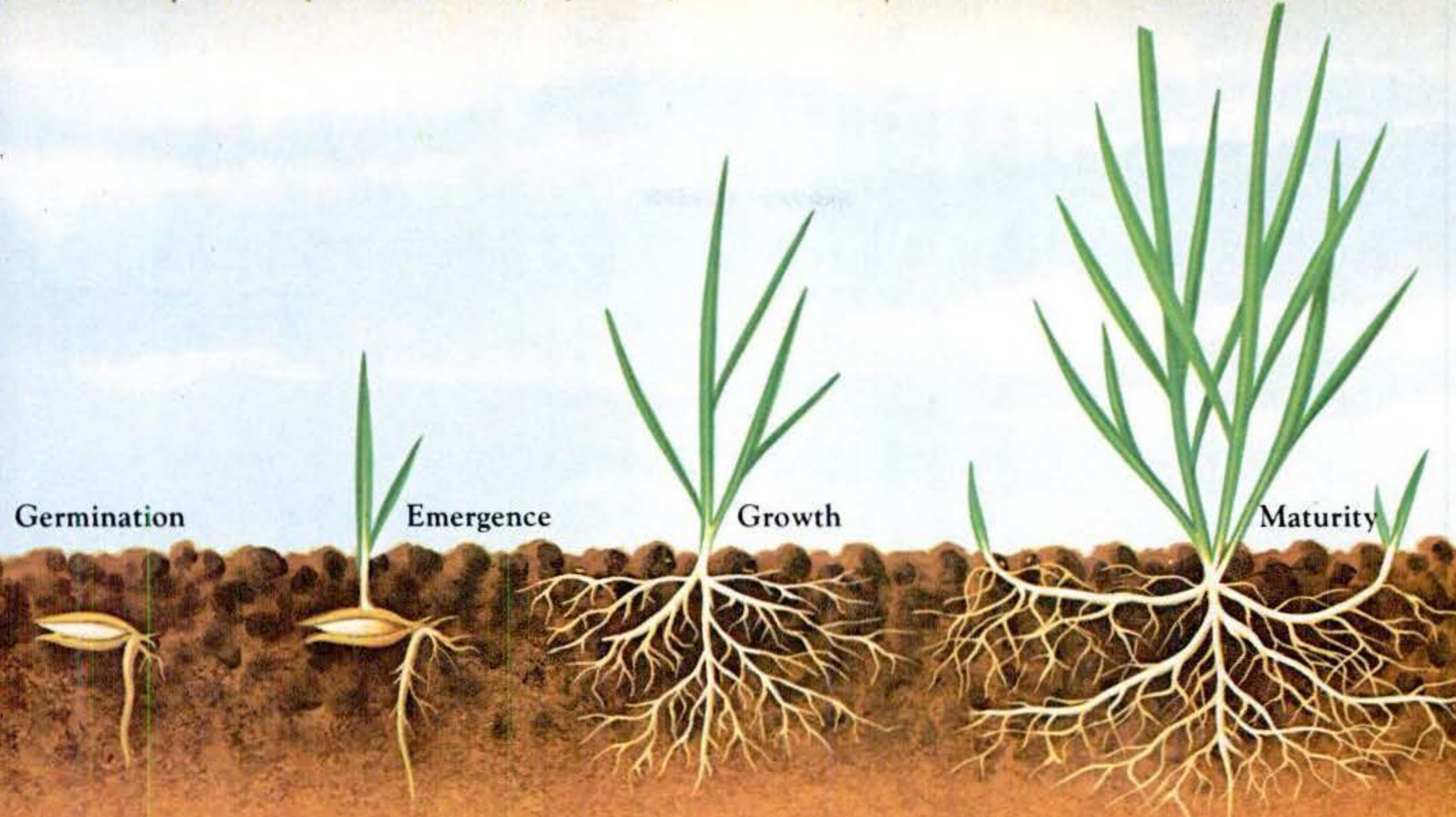

Germination

Emergence

Growth

Maturity

Our seed is guaranteed to have a future.

It takes a pretty robust seed to germinate and survive. That's why, at Scotts, we sort the seed that goes into our mixes.

We get rid of most of the weak immature seeds that have little chance of making it and keep the plump mature seeds that are full of vigor. In fact, we're so particular, last year we rejected over five million pounds of seed that didn't measure up to all our standards.

The plump healthy seeds in our Family* mixture have food reserves to help them sprout and grow faster. They also grow roots that can dig down faster for food and water, so more seedlings survive.

Family seed will give you a green, fine-textured lawn that's a joy to behold. And it comes with this simple guarantee, "If for any reason you are

not satisfied with results after using this product, you are entitled to get your money back. Simply send us evidence of purchase and we will mail you a refund check promptly."

When you have seed like this, you can afford to have a guarantee like that.

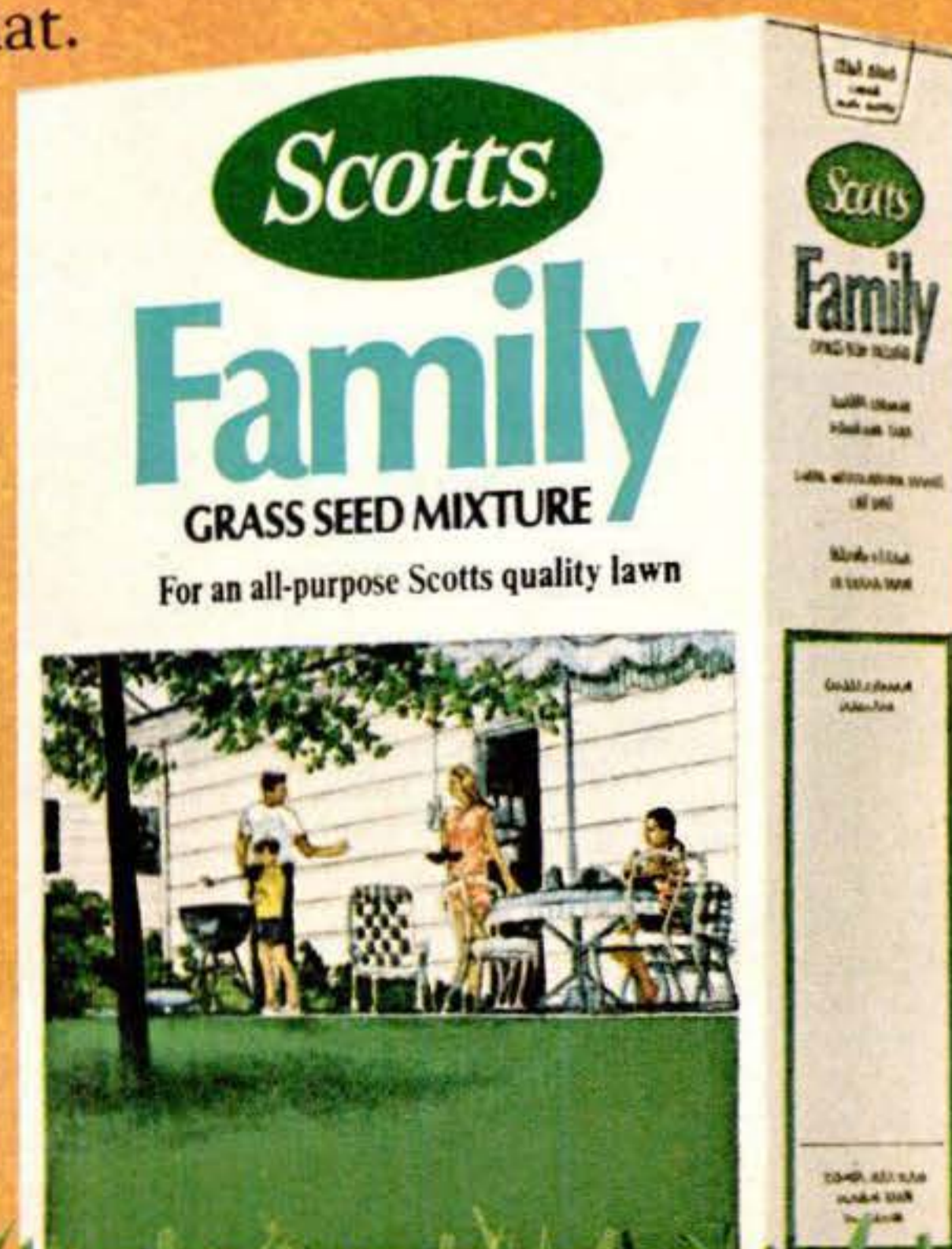

Best fuel economy of any mid-size wagon.



Fairmont Squire Wagon

1980 Ford Fairmont.

Better MPG for 1980.

Fairmont wagon is the right idea for today. Its standard 2.3 liter, 4-cylinder engine has remarkable gas mileage for a wagon.

If you're like many wagon buyers and want a 6-cylinder engine, consider this. Fairmont's 6-cylinder has an excellent estimated MPG of 21. No 6-cylinder wagon sold in America—foreign or domestic—beats it.

23

EPA
EST.
MPG

38

EST.
HWY.
MPG

322

EST.
RANGE

532

EST.
HWY.
RANGE

Compare this 4-cyl. est. mpg to other wagons, excluding other Ford Motor Company wagons. Your mpg and range may differ, depending on speed, distance and weather. Actual hwy. mpg and range will probably be less than estimates. Calif. mpg lower. Range based on EPA mpg estimates and Fairmont's 14-gallon fuel tank.

No American-built mid-size has more cargo space.

Fairmont has been engineered for people, to be trim on the outside yet remarkably spacious inside. It's an ideal combination for today's needs. Based on the EPA index, there is 43 cu. ft. of cargo space with the rear seat up and five-passenger seating.

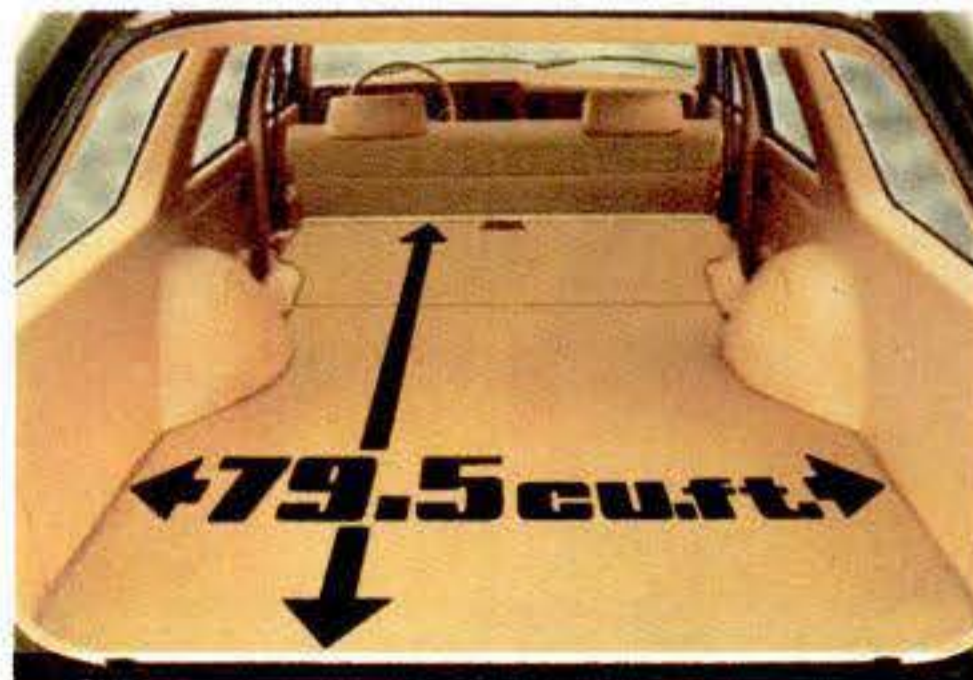

For even more room, fold down the rear seat for 79.5 cu. ft. and almost 7 feet of cargo space. That's versatility.

A standard of wagon value.



You'll find Fairmont's low sticker price and standard features a pleasant surprise. Choose from a versatile base to the classic Squire Wagon. And be sure to ask your Ford Dealer about the optional Extended Service Plan.

THE RIGHT IDEA FOR TODAY.

FORD FAIRMONT

FORD DIVISION



ALTERNATE-ENERGY ANSWERS

By JAN F. KREIDER

Jan. F. Kreider is a consulting engineer specializing in the design and economic analysis of solar-energy and energy conservation systems. He is the author of several books on solar technology, and a lecturer at the University of Colorado.

Set thermostat by phone?

As the owner of a weekend house, I would appreciate knowing if there is a thermostat that can be actuated by telephone to advance heat prior to arrival at the house. I think such a device would be of interest to many people in similar situations.

Robert E. Richer, New York, N. Y.

Indeed, there is a device that interfaces between your existing thermostat and telephone, allowing you to actuate the furnace by telephoning your home number. It's called the Tele-Commander, and is made by G2 Enterprises (255 W. 90 St., New York, N. Y. 10024). [For more information, see the photo and caption in "What's New in Home Improvement" in this issue.]

Winter and summer sun angles

Could you tell me the sun's angle in winter and summer in Indiana? How can I get the ASHRAE Handbook?

Chester Paskell Jr.
Anderson, Ind.

The altitude angle A of the sun above the horizon at noon can be calculated from this simple equation:

$A = 90^\circ - \text{latitude} + \text{solar declination}$
The solar declination relates the position of the sun at noon to the equator, and is given in tables in *The American Ephemeris and Nautical Almanac*. It can also be calculated from the equation below to $\pm 1/2^\circ$:

$$\text{dec.} = -23.5^\circ \times \cos \left[(N + 10) \frac{360}{365} \right]$$

where N is the number of days elapsed in the year. For example, on March 10 ($N = 69$) the declination is -5° and the altitude A is 45° for Anderson, Ind. (latitude = 40° N).

The ASHRAE Handbook contains a full set of solar-angle equations and is available from ASHRAE, 345 E. 47th St., New York, N. Y. 10017.

Solar-assisted oil burner

In my home, the hydronic space heating and domestic hot water are in one unit, fired by an oil burner. I'm thinking of combining a solar system with my present system by interrupting the boiler feed line, adapting it to flexible PVC pipe, and running this pipe out to the top of my carport. There it will be curled into a helix to preheat the boiler water. Will this arrangement work?

Dr. Frederic F. Porcase Jr.
Miami, Fla.

I assume that the boiler feed you speak of is the baseboard-heater water return line. If so, this line will be at 160 degrees F or so and will actually lose more heat through the coiled pipe than the sun could ever supply. In addition, the coil will lose enormous amounts of heat at night unless you cut it out of the circuit with a three-way valve, in which case the coil could freeze (even in Florida, solar systems have frozen).

If you planned to use your coil to pre-heat your domestic hot water, you will also have problems. One hundred feet of one-inch pipe contains only four gallons of water. This small amount of water could be preheated by your method, but a much better way is to use some sort of collector and continuously circulate the fluid through it during the sunny hours of the day. This way you could provide one gallon of hot water from each square foot of collector area per day, on the average.

Wood-heated hot water

We just installed a wood stove to heat our home of 1800 sq. ft. Has anyone written about the installation of a hot-water heater in a wood stove? I would like to install an electric hot-water heater that could work on electricity or heat from the stove.

Kenneth S. Curbow
Manchester, N.H.

Yes, there are commercially available units for thermosiphon water heating from a wood stove. I would suggest that you get the September 1979 issue of *Solar Age* magazine (SolarVision, Inc., Church Hill, Harrisville, N.H. 03450) for a good review of currently available hardware. Tests reported in that issue indicate that this type of water heating works quite well when the firebox is operating. Since very hot water is produced under such conditions, you may want to add an automatic mixing valve to prevent the possibility of scalding.

Adding solar hot water

I would like to build a solar water heater and hook it into a system that already has a conventional heater. I understand that unless the hookup is made properly, either one heater or the other will do all the work.

Raymond Ivall, Sarasota, Fla.

Since you already have a water heater (with a bottom heating element) you will need to use a two-tank system. The new tank can be another water heater like the one you own but without the heater

hooked up. Disconnect your city water line and reconnect it to the inlet dip tube of your new tank. Connect the old cold-water inlet on your present tank to one of the top fittings on the new tank. Finally, run the solar-collector outlet to another top inlet to the new tank and connect the collector supply line to the bottom fitting of your new tank. You need a pump to flow 1150 gpm per square foot of collector and a controller to turn the pump on and off at the right time. The Florida Solar Energy Center at Cape Canaveral has a good manual on this subject.

Hot foot

I already use solar collectors to heat my outdoor pool, but each time I burn my feet on the flagstone decking I lament all that heat going to waste. I have considered placing rubber pipes or pipes in rubber mats underneath the flagstones to collect some heat. Do you know of any other method or materials I might consider?

Roger N. Johnson
Los Angeles, Calif.

There is a fundamental difference between temperature and heat. Your deck is hot precisely because little heat is removed from it except by reradiation and convection to the environment. The more heat removed by some sort of water system the cooler the deck will be. However, a rubber arrangement under the flagstones will not work well since this material is a relatively poor conductor of heat. In other words, solar heat will diffuse downward through the deck too slowly to do much heating. The rubber collector you mention will work much better if exposed directly to the sun.

Attic ventilation

I live in a small, brick, one-story house with central air conditioning. I was about to purchase a power ventilator for the attic space when I read that some studies show these ventilators will not save enough energy to pay for the cost of running them.

Lowell Toms, Atlanta, Ga.

Whether it's worth power ventilating depends on two things: the level of insulation in the roof and the cost of a fan (prorated over several years), plus the power to run it. All you need to do is make certain that the value of the reduction in heat gain into the structure from the attic is greater than the prorated value of the fan and its operating electric power. To make this decision, determine the R-value of your roof and the costs mentioned above, and make the comparison.

Got a question on an alternate energy such as solar, wind, water, or wood? Or on energy-conservation techniques that could reduce your home's heating and cooling costs? Every other month, alternating with "Adventures in Alternate Energy," Jan Kreider answers questions selected from those sent in by readers. Write to "Energy Questions," POPULAR SCIENCE, 380 Madison Ave., New York, N.Y. 10017. Queries can't be answered by mail.

People write to



Have a question about motor oil? Lubricants? Engines? Ask the Pennzoil experts...

Follow The Rules. The owner's manual for my 1977 Toyota specifies the use of a SAE 90 GL-4 lubricant for the manual transmission and steering gear box, and a SAE 90 GL-5 lubricant for the differential. Would it be acceptable to use Pennzoil 4096 Gear Lubricant, SAE 80W-90, GL-5 and 6 for all three applications?

W.G.S., Mercer Island, WA

We would not recommend that you use Pennzoil Gear Lubricant #4096 in the manual transmission and steering gear box of your Toyota since this lubricant is rated for API Service GL-5 and 6. As shown in your owner's manual, these units call for GL-4, a gear oil with reduced additive content. Pennzoil GL-4 Gear Lubricant is the proper oil for these uses. Pennzoil #4096 can definitely be used in the differential, however, and meets all of the requirements of Toyota.

All Points Bulletin. My 1969 Volvo runs really well, but has trouble starting readily when it's hot. What do you think is the problem?

V.L.C., Mt. Vernon, NY

The fact that your engine will not readily start when hot may be due to any of a number of things. You should check the compression on all of your cylinders. You should also check the automatic choke for a faulty heat riser. Then check timing, carburetion and see if you might have a plugged air filter. If the air intake system appears to be operating properly, then a complete check should be made of all electric systems such as points, plugs, condenser, coil and starter motor.



Short Circuited. The fuses in my car keep burning out one right after another. The lights on my dashboard are

constantly going out. What do you think could cause this to happen?

R.C., Cicero, Illinois

When fuses repeatedly burn out, the cause is usually a short circuit due to insulation being worn out and the hot wire grounding somewhere along that circuit. This could be the result of a wire chafing on a sharp metal edge somewhere behind your dashboard. The only solution is to physically inspect all wiring protected by that fuse. When you find the source of the problem, tape it up with plastic electrical tape and, if possible, re-route the wire to avoid developing another short in the future.



Ping Strikes Again. I've been having a problem with reoccurring pinging in 2 of my cars. What causes engine ping? What can I do to stop it?

J.Z., Grafton, Wisconsin

Engine ping results from pre-ignition of gasoline before the piston reaches top dead center prior to the power stroke. This is caused by having the ignition timing advanced too far or by using a poor grade of gasoline which is unstable and pre-ignites. The solution to engine ping is to use a higher octane fuel or retard your cars' ignition timing to accommodate the lower grade of fuel. However, you should stay within manufacturers' tolerances on timing because of exhaust emissions.

Less Is Best. I've been puzzled for quite some time now between the automobile manufacturer's recommendations for oil changes every 6,000 to 7,500 miles and my dealer's recommendation that oil be changed no less often than every 3,000 miles. What are your comments on this?

D.G.W., Los Angeles, CA

In your owner's manual you will find

two oil recommendations: one for normal driving conditions, and another for adverse driving conditions. The maximum oil change interval could be 6,000 to 7,500 miles, while under adverse conditions this is reduced to 3,000 miles. In your area, and in most large metropolitan cities, driving conditions are adverse with considerable stop and go driving, extended idling and heavy traffic conditions. We agree with your dealer's recommendation of 3,000 mile oil change intervals if you expect maximum performance and long engine life.

Rid Of Rust. I recently noticed that the car I just purchased has a Pennzoil X-280 rustproof seal. What type of product is X-280 and what functions does it perform?

E.T.M., Louisville, KY

Pennzoil X-280 is a petroleum resin providing superior protection for automobiles and trucks. This product may also be used as an undercoating. The compound is formulated to rustproof hard to reach areas such as rocker panels where more than 85% of the rust originates. This product seals the interior metal parts and undercarriage against moisture, pollutants, salt and other chemicals.

WE'RE OPEN TO QUESTIONS about motor oils, lubricants, engines. But, you can tell us a few things, too. Maybe you have discovered something interesting about motor oils or lubricants. Or you have a special reason for being a Pennzoil fan. We would like to hear from you. Write to: Pennzoil Company, Research Department, P. O. Box 808, Oil City, Pennsylvania 16301. Note: sorry no pictures or material can be returned. Letters chosen for publication are subject to revision necessary for publication requirements.

Quality Products For Over 90 Years

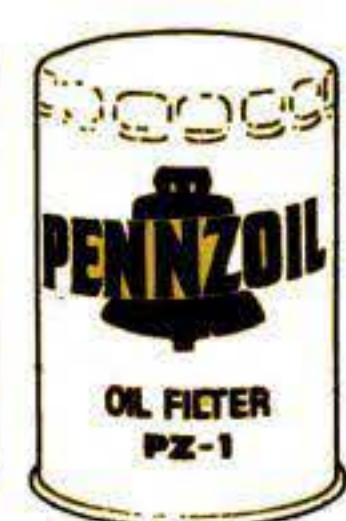

ask for it!

DETROIT REPORT

By JIM DUNNE



Chrysler K-body preview

Above are photos of two of Chrysler's 1981 front-wheel-drive K-body compacts, the two-door coupe and four-door station wagon. In an unprecedented move to convince Congress to approve the controversial loan-guarantee bill designed to save his company, Chrysler president Lee A. Iacocca sent these pictures to each of the 535 members of Congress, accompanied by the following: "Here is the future of Chrysler. Your 'yes' vote will allow Chrysler to build one million 25-30-mile-per-gallon cars like these and smaller. A 'yes' vote puts them into production in less than ten months." (As this column went to press, Congress passed a loan-guarantee bill designed to bail Chrysler out of its financial difficulties.)

How they'll compare

Chrysler will introduce the K-bodies as 1981 models to replace the current Aspen/Volare. They will have a boxier look than their General Motors X-body competitors, mainly because of a 99.6-inch wheelbase and a higher roof line. The similarity to

Buick's Skylark X-body is unmistakable, but the Chrysler products look a bit stubbier. The wheelbase will be within a half inch of the Omni/Horizon's (99.2 in.) because cars with less than a 100-inch wheelbase are exempt from certain federal seat-belt regulations, and Chrysler is taking full advantage of that.

GM's 1983 big cars

The 1983 full-size General Motors cars will include some of the most radical changes ever in GM big-car design. New bodies, smaller outside dimensions, new front-wheel drive, and V6 engines are in the works for Cadillac, Oldsmobile 88 and 98, Buick Electra and LeSabre, Pontiac Bonneville, and Chevrolet Caprice. V8 engines will be replaced by V6's across the board, and a host of mechanical changes will be made, including rack-and-pinion steering mounted on the firewall, McPherson-strut front suspension, and four-bolt wheels (replacing today's five-bolt setup). Some bumpers will be eight-inch-thick plastic-foam bars covered with a plastic cap that matches the car's paint color (a first for GM). Weight savings will be evident

throughout, and while GM's new, common body will be revolutionary for big cars—including some hatchback models—the interiors will offer virtually the same room as today's models. "We don't intend to build the inside of our big cars any smaller than today's models," one GM executive explains. Fuel-economy improvements could amount to as much as five mpg over current models. Performance will be about the same, though, due to lighter overall weights.

Pontiac sports car

After years of proposals, Pontiac has finally gotten the green light to produce a full-fledged sports car. Planned for 1983½ introduction, the plastic-bodied two-seater will use the same drive train as the Phoenix X-body, but with one big difference. Instead of using front drive, the whole power train will be moved aft to create a midship-engine layout. The body will be smaller than Corvette's (with a design weight in the 2000-pound range), and will resemble Fiat's X1/9, a similar midship-engine sports car.

1981 Ford Escort/Mercury Lynx

The forthcoming replacement for the current Pinto/Bobcat (originally code-named Erika) will be built as a two-door hatchback and a two-door wagon. Styling will be similar to Ford's Fiesta, while the front end will look like a cross between Concord and Horizon. The drive train will have a transversely mounted four-cylinder engine of either 1.3 or 1.6 liters. The 160-inch design length will be nine inches shorter than today's Pinto coupe, 19 inches shorter than the wagon. Ford expects to cut weights about 400 pounds, bringing in the new cars at around 2000 pounds. This will boost highway fuel economy of the base 1.3-liter-engine model to the mid-40-mpg range.

Garrett's flywheel-electric

Garrett, the manufacturer of AiResearch turbochargers, is building a commuter car with a flywheel-electric power train. The flywheel weighs 50 pounds, is enclosed in a vacuum to prevent air-drag losses, runs at a peak of 25,000 rpm, and furnishes all power for the car when spinning fast enough. A 1000-pound battery pack brings the flywheel up to speed in less than a minute. In theory, the batteries would be used only to rev up the flywheel, or for quick starts. A variation of the system, for transit buses, uses a small diesel engine instead of batteries.

GM reviving mini-van

The mini-van GM once planned to introduce along with the X-cars—but which was shelved somewhere along the line—was revived last fall when sales of full-size vans plummeted. GM will use the X-body front-drive system, including V6 and four-cylinder engines, in a smaller van body suited to city delivery and small hauling jobs. Fuel economy of 25-35 mpg will be the biggest selling point over the full-size vans. PS

Allison's wind engine

— spiraled blades
for high efficiency



Unique multiblade mill delivers 56 percent of the power that's blowing in the wind

By **PENELOPE WRIGHT**
and **BRADLEY STEVENS**

"Watch this," says the inventor with a glow of anticipation. An eight-blade windmill looking vaguely like a segment of a circular stairway is placed in the basement wind tunnel. It leaps into motion, producing a thrashing whine. A handful of weights goes on a torque-testing brake; the speed of the windmill slows and the sound changes to a steady, powerful tone. It is impressive.

William Allison, an automotive engineer from Detroit, has developed a multiblade windmill that looks unlike any previously known windmill and, according to the designer, will outperform other wind machines.

"Conventional propellers are not getting all of the energy that is available in the wind," Allison claims. "Their design allows too much energy-laden air to go around the blades, which lowers efficiency. I think my wind engine can do better." The bold words invite a closer look at this unusual wind turbine.

Dubbed "wind engine" by its creator, the windmill features four pairs of blades arranged in depth (shish-kebab style) along a horizontal axis at a measured distance and angle from each other. Though Allison has skewered as many as eight blade pairs and

Continued

Ex-automotive engineer William Allison is shown with one of his windmills, an eight-blade, six-foot version.

Warning: The Surgeon General Has Determined That Cigarette Smoking Is Dangerous to Your Health.

The rich low 'tar.'



Enjoy the first low 'tar' good enough to be called rich.

Rich Lights

from Viceroy

Only 9 mg 'tar'

9 mg. "tar", 0.8 mg. nicotine av. per cigarette by FTC method.

JEEP TRUCKS

IT TAKES A TOUGH TRUCK TO TAKE ON A TANK

Who'd believe that tough, sporty Jeep Trucks have anything in common with a tank? Well, they do. Because beneath our Jeep Trucks' good looks lies unbeatable traction from famous Jeep 4-wheel drive. Fact is: if you want better traction, you'll just have to get a tank.

Our Jeep Trucks have great ground clearance, too. And they're out in front when it comes to handling and maneuverability. Besides, a Jeep Truck will look a lot better in your driveway than a tank.



We wrote the book on 4-wheel drive



EJECT FROM AN EXCITING OF SPORTY JEEP TRUCKS

Whatever your trucking needs are, you fill them with any one of our Jeep Trucks. Sport, Jeep Pickups fill the bill—in terms of size, payload capacity and performance. When it comes to style, check out our Sportside Pickup.

There's a payload capacity that's just right for you. In fact, our standard J-10 Pickup has a greater payload capacity than comparable Ford, Chevy or Dodge pickups.

What's more, for 1980, part-time 4-wheel drive is available with automatic transmission. So now, with all Jeep Trucks you can take advantage of economical 2-wheel drive when you need it, switch to the proven traction capabilities of Jeep's unbeatable wheel drive. Or, for the ultimate in traction convenience, you can get Quadra-Trac®, our exclusive automatic 4-wheel drive system.

Jeep Trucks...they're built for your trucking needs...each and every one of them.



Sportside, all new for 1980

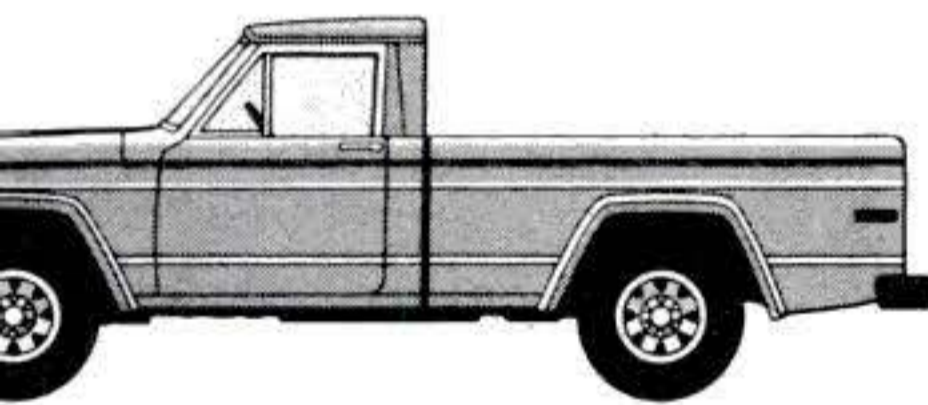

The 1/2-ton performer

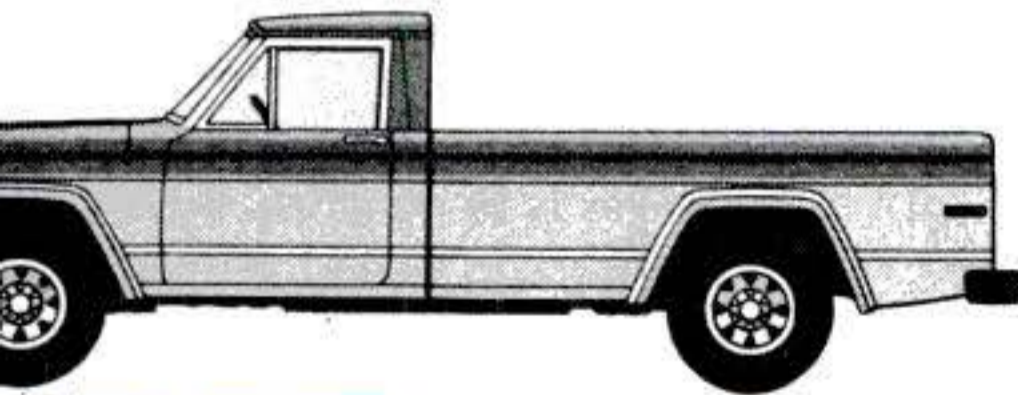

The 3/4-ton workhorse

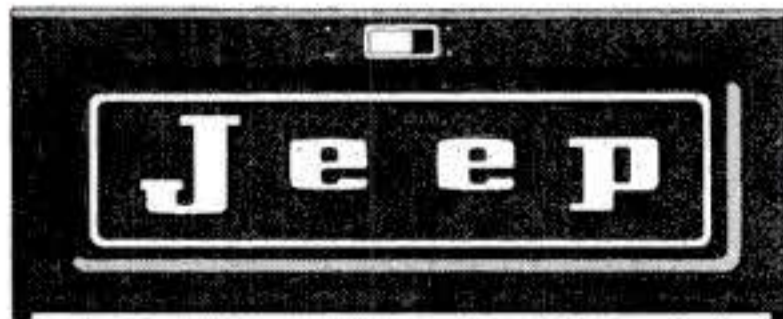

FROM THE TRUCK DIVISION OF JEEP CORPORATION,

Jeep Corporation, a subsidiary of American Motors Corp.

Wind engine

[Continued]

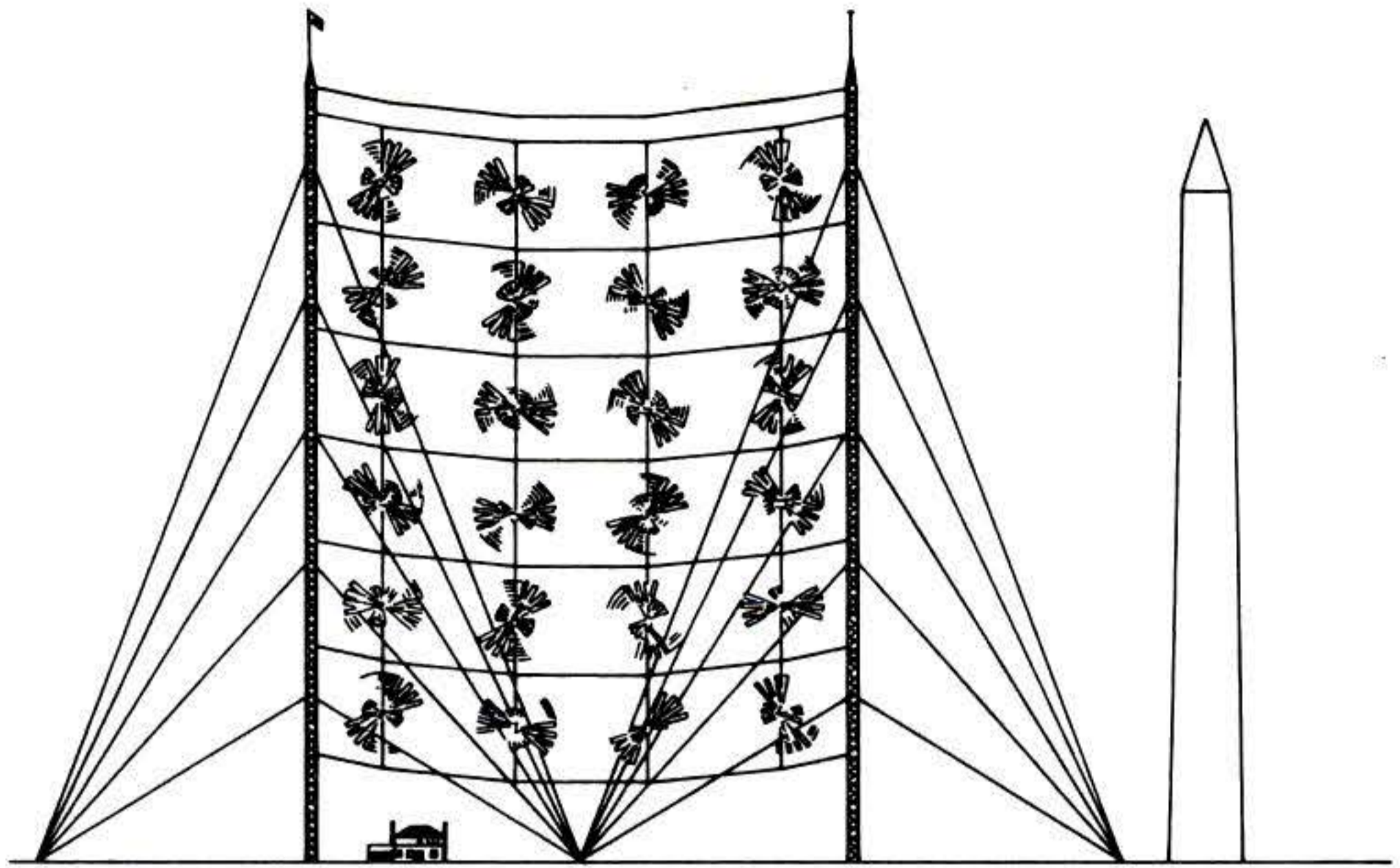

Allison envisions huge arrays of his windmills hung "clothesline-fashion" between

towers 300–500 feet high for large-scale electric-power production.

as few as a single pair, his tests show that four or more pairs have the highest efficiencies—extracting more than 56 percent of the energy in low velocity winds of eight to 12 mph. (Fifty-nine percent is the theoretical maximum that can be extracted by a wind turbine.)

Connected by spars to the main shaft, the blades in the helical arrangement lack the traditional airfoil shape. Rather, they are fabricated with knife edges and a flattened triangular cross section, and present their longest face to the wind. The blades have pitch, but no progressive twist from stem to tip.

Bill Allison believes the new windmill can successfully:

- Achieve higher power-extraction efficiencies compared to other propeller designs;
- Generate electricity at wind velocities ranging from four to 50 mph without feathering;
- Lend itself readily to low-cost production; and
- Permit grouping in multiples from suspended cables for large-scale electrical production.

Is Allison close to realizing his dream? The propeller designs have undergone testing and evaluation at the University of Massachusetts and University of Michigan wind tunnels. Preliminary tests are encouraging.

Allison admits that his present dedication to designing high-performance windmills began as an amusing pastime. When he retired the same year as the Arab oil embargo, he automatically looked to wind power for solutions to the energy shortage. After observing both private and government

attempts at generating electricity with windmills, Allison saw room for improvement and set to work on a long program of experiments.

First a wind tunnel arose in his well-equipped shop, along with 15-inch precision copies of both the well-known Wincharger two-blade wind generator and the federal government's giant two-blade windmill located at Plum Brook [PS, July '74]. Then followed a long succession of blade designs (154 at last count).

Puzzling test results

Small-scale testing showed consistently that the Allison eight-blade turbine, compared with the two-blade propeller, started in lower winds, ran at a slower speed, developed far more torque, and pulled more horsepower. The results both amazed and puzzled the inventor.

"The eight-blade helical windmill runs (at peak power) about half as fast as a two-blade with the same airfoil [blade] and diameter," says Allison, "yet it pulls substantially more horsepower and works effectively over a much wider range of wind velocity."

How does Allison account for the higher blade efficiencies? He believes the wind engine extracts more of the wind's power by regulating and controlling a phenomenon he calls "pressure pileup," which he demonstrates.

He places a 15-inch-diameter solid disc in the wind tunnel. The bearings that hold the disc on the spindle experience high thrust, but the disc does not turn. Allison observes that as the airstream encounters the disc, the air slows down, increases in pressure, and

Continued

tends to pile up in front of the disc, creating what he terms a "pressure pileup." This pileup forms an invisible block that forces the oncoming air to go around the disc without producing work or power.

Allison contends that any windmill blade creates a blockage to the windstream (though not as totally as the disc), and forms a pressure pileup as it cuts through the air. The pileup or slowed-air zone forces significant amounts of wind to go around the perimeter of the blades without making contact. In the case of the two-blade propeller, the air that eventually goes

through the windmill is considerably weakened and has less energy to impart to the blades.

"The multivanes I am working with have depth," says Allison. "When you put on the extra blades the pitch angle is higher and the wind is not slowed as much as with the flatter pitch angle of the two-blade turbine. With the eight-blade propeller the pressure pileup zone is pretty much through the turbine before the opposite blades come around. So more undisturbed air travels through my system, which allows my blades to pull more power."

By actual observation with a smoke generator and a strobe light, Allison has determined that the pileup from a two-blade windmill takes the form of a cone. In a 12-mph wind the cone in front of a 15-inch-diameter blade is about four to five inches deep. Allison's measurements show that the pileup from the two-blade propeller may spill as much as 40 percent of the total energy of the wind. According to the inventor, the blockage from the eight-blade propeller never gets that large. His propeller sweeps itself clean of the blockage. This is the big difference between conventional two-blade turbines and Allison's.

Assembly-line production

A Michigan-based firm, Environmental Energies, Inc., has been testing a 20-foot-diameter proof-of-concept model of the Allison turbine for six months. So far, test results confirm predicted efficiencies. Company officials also say that the blade, built of sheet metal with no complex curves, is well suited to low-cost mass production. Allison has purposely designed his windmill to be built with conventional technology using assembly-line techniques. Wherever possible, he has eliminated costly control devices.

There is no pitch-control mechanism on the windmill—the blades have a fixed pitch. Allison's testing indicates that the optimum pitch angle depends on the number of blade pairs he skewers. For the eight-blade configuration he sets the blades at a 12½ degree pitch. This higher angle, combined with a slower rotational speed, allows the helix to turn with useful torque at four mph and continue extracting ever-increasing power up to any desired windspeed (depending on the wind characteristics of the site). Plans call for the use of a variable-speed generator tailored to the torque characteristics of the windmill.

Allison, who holds some 70 patents, has been awarded two patents on his windmill. At present, he has licensed three companies to build versions of it, including Environmental Energies, and he hopes to interest a major company in backing a large-scale power venture (see drawing). On a smaller scale, Environmental Energies has recently been awarded a contract by the Michigan Dept. of Transportation to provide wind-generated electricity for a new roadside information center. Work is in progress on a 24-foot-diameter version of the eight-blade windmill for the site. ES

How To Be Sure You're Getting The REAL THING

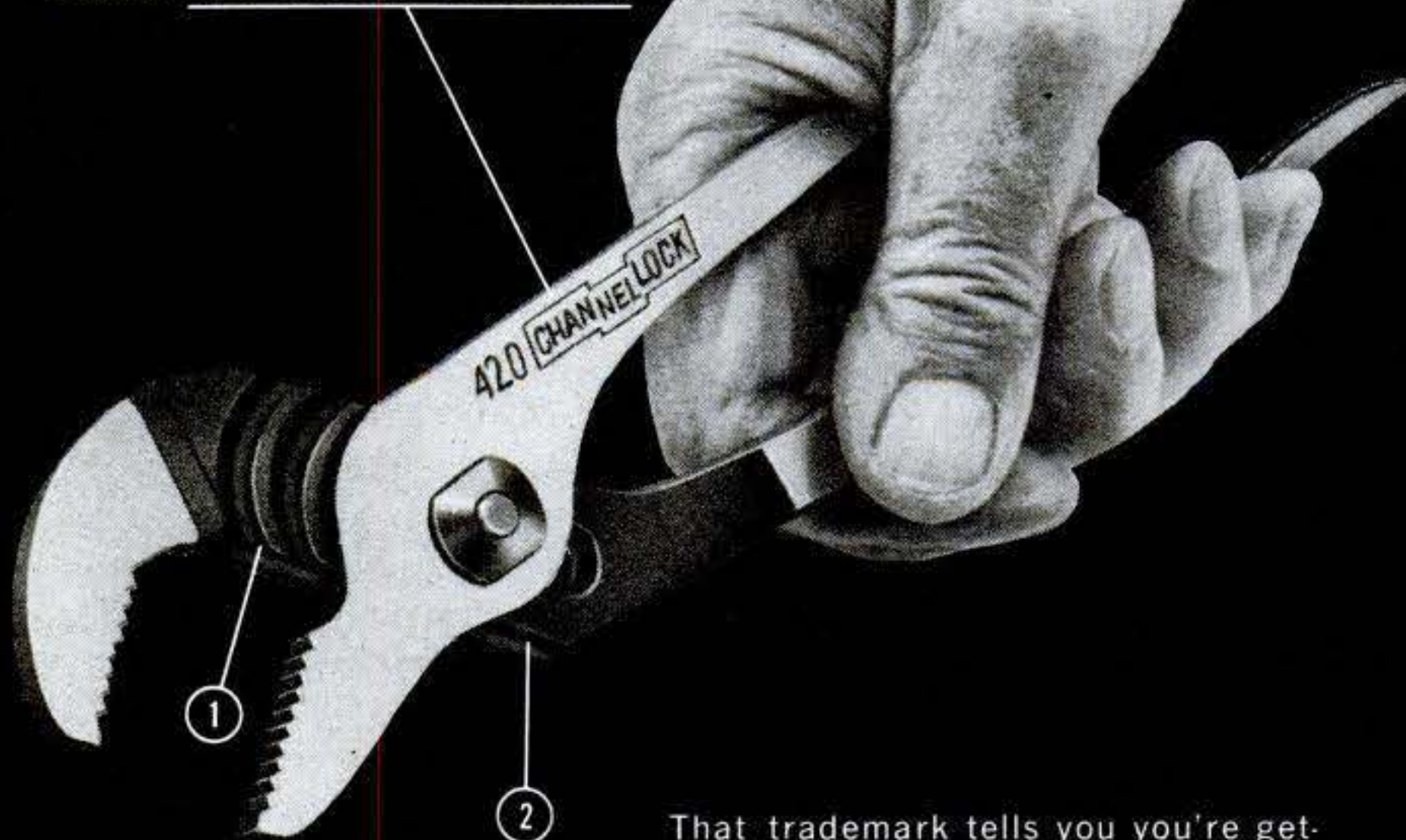

That trademark tells you you're getting the ORIGINAL. The real thing. The tongue-'n-groover with smooth working, machined, undercut mating parts (1) that can't slip. The one with the reinforcing flange (2) that practically eliminates stress breakage. First of its kind and still best of its kind. Be sure you get the genuine CHANNELLOCK. Look for the trademark on the handle. Sizes from midget 4½" to giant 16".

CHANNELLOCK, INC. • Meadville, Pa. 16335

CHAN NEL LOCK

The ORIGINAL Tongue-'N-Groover



Send For Our Free Catalog

Fast-talking cassette player

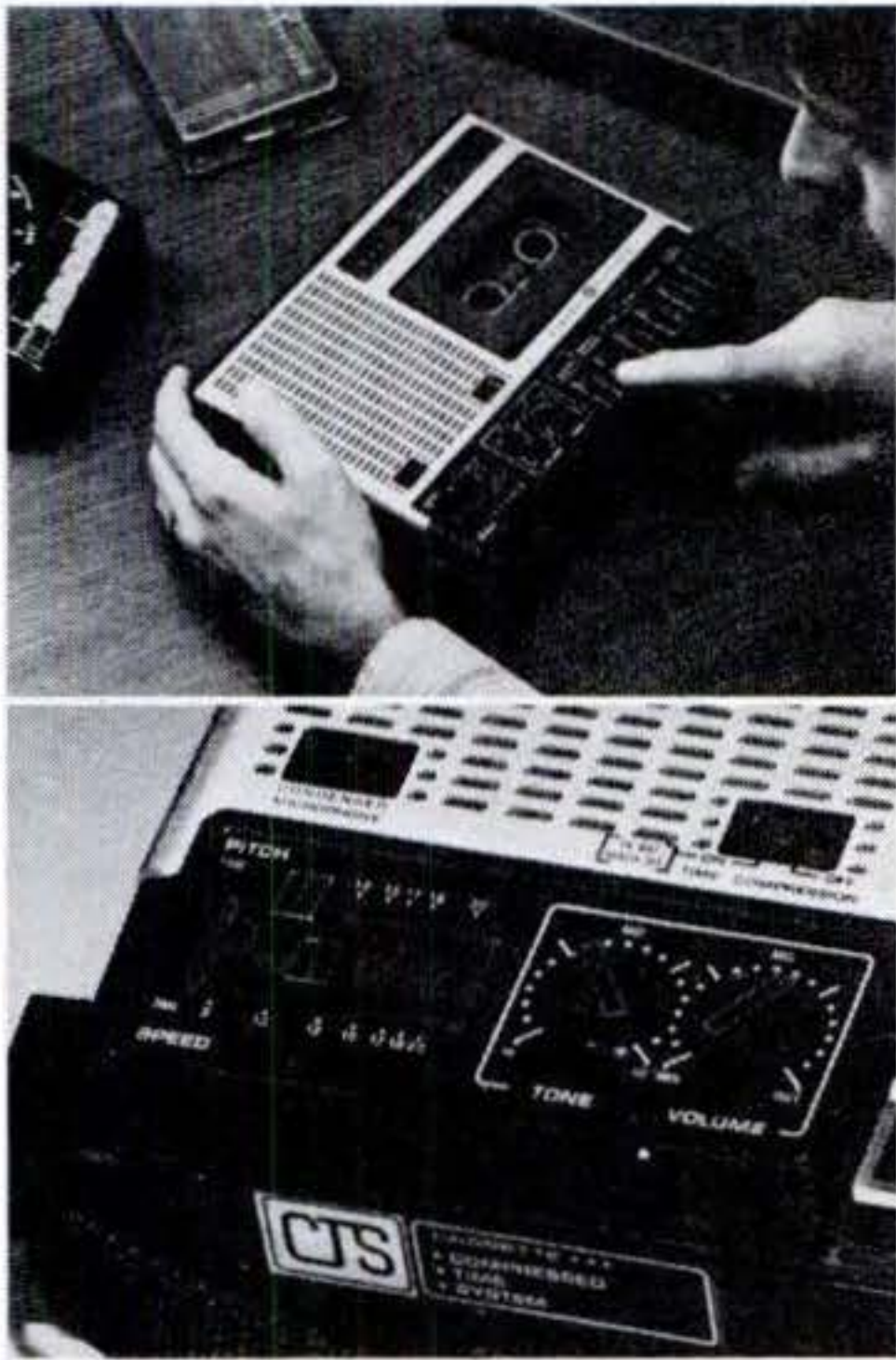

The nice thing about using a tape recorder for transcribing is that you never lose a word. You do lose time, though—it takes as long to listen to a tape as it did to record it. At least it used to.

Now you can use this new GE compressed-time-system (CTS) cassette recorder to listen fast. Speech recorded in normal time, from old or new tapes, can be played back at up to twice the speed without losing clarity or sounding like Donald Duck.

The deck uses an electronic bucket-brigade device (BBD) that chops sentences into analog bits of information that are electronically compressed.

The machine has two special controls: speed and pitch. As you increase the speed, you must simultaneously increase the pitch to compensate, eliminating the Donald Duck sound.

I could easily comprehend a tape running at up to 1.6 times normal speed. As I increased above that, however, I also had to increase my concentration. Listening at twice the normal speed takes practice.

Besides speed listening, the recorder has all the features you'd expect in a top-end model: digital counter with memory for finding specific places on tape automatically, automatic recording level, VU meter with battery-condition display, pause, tone, and audible cueing controls.

The deck is AC/DC operable, but can only use the CTS system when powered by house current. The GE 3-5195 is \$198.50.—*W. J. Hawkins.*

Greg Wessel, how long do you want your car to last?

"I've been asking myself that question for the past 10 years. See, this '68 Camaro is kind of special to me. It was the first new car I ever owned, a red convertible, no less. And before we got married, I'd drive back and forth across the mountains to Reno every weekend to visit Karen—whether it was snowing, sleeting or whatever. The car never let me down! Even now it does a lot of rough driving 'cause it's the car we use when we go skiing.

"Of course I take good care of it. I do all my own mechanical work at regular intervals, including tune-ups and oil changes. And I always use Quaker



State Motor Oil. I've been so satisfied with the results that I put Quaker State in our new 'second' car right from the start. I hope it'll last as long as the convertible has, although I know it's a hard act to follow. I've got well over 100 thousand miles on the old car now, but I'm still not making plans to turn it in yet."

—*Greg Wessel*

*Greg and Karen Wessel,
Foster City, California.
They're still enjoying their 1968 Camaro
with over 100 thousand miles on it, while
'breaking in' their '75 Opel on Quaker State—
63 thousand miles worth.*

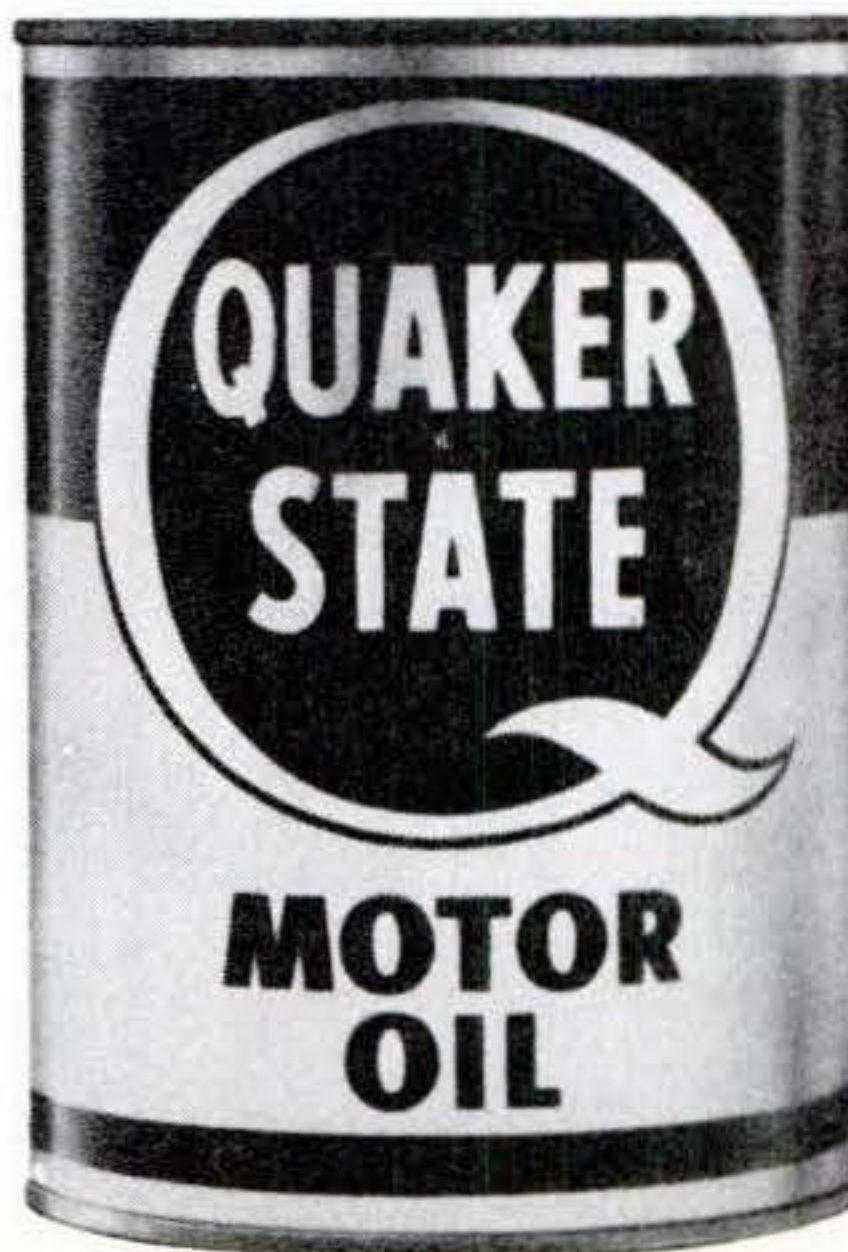
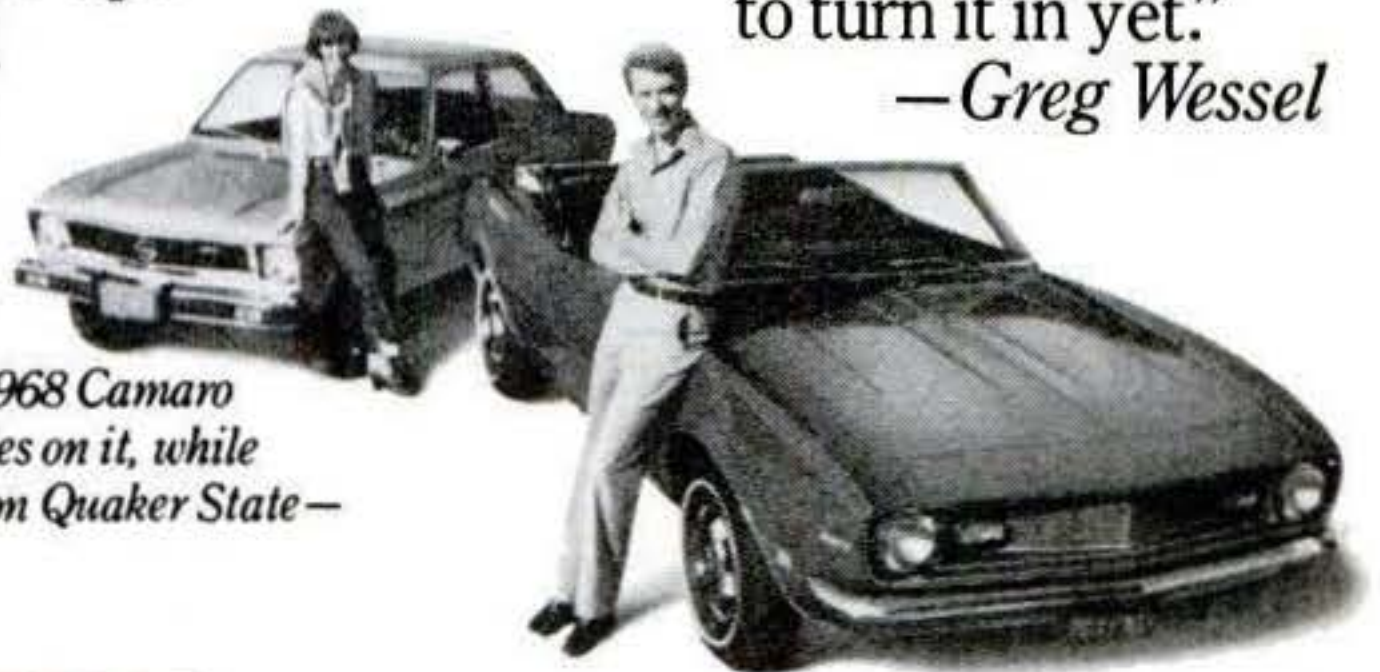

Helps cars last.

Keep our neighborhoods clean. Take your used oil to a collection center.



Discover full
menthol refreshment
without all that 'tar.'
Discover Arctic Lights.

Low 'tar': Kings & 100's

9 mg. "tar", 0.8 mg. nicotine av. per cigarette by FTC method.

Warning: The Surgeon General Has Determined
That Cigarette Smoking Is Dangerous to Your Health.

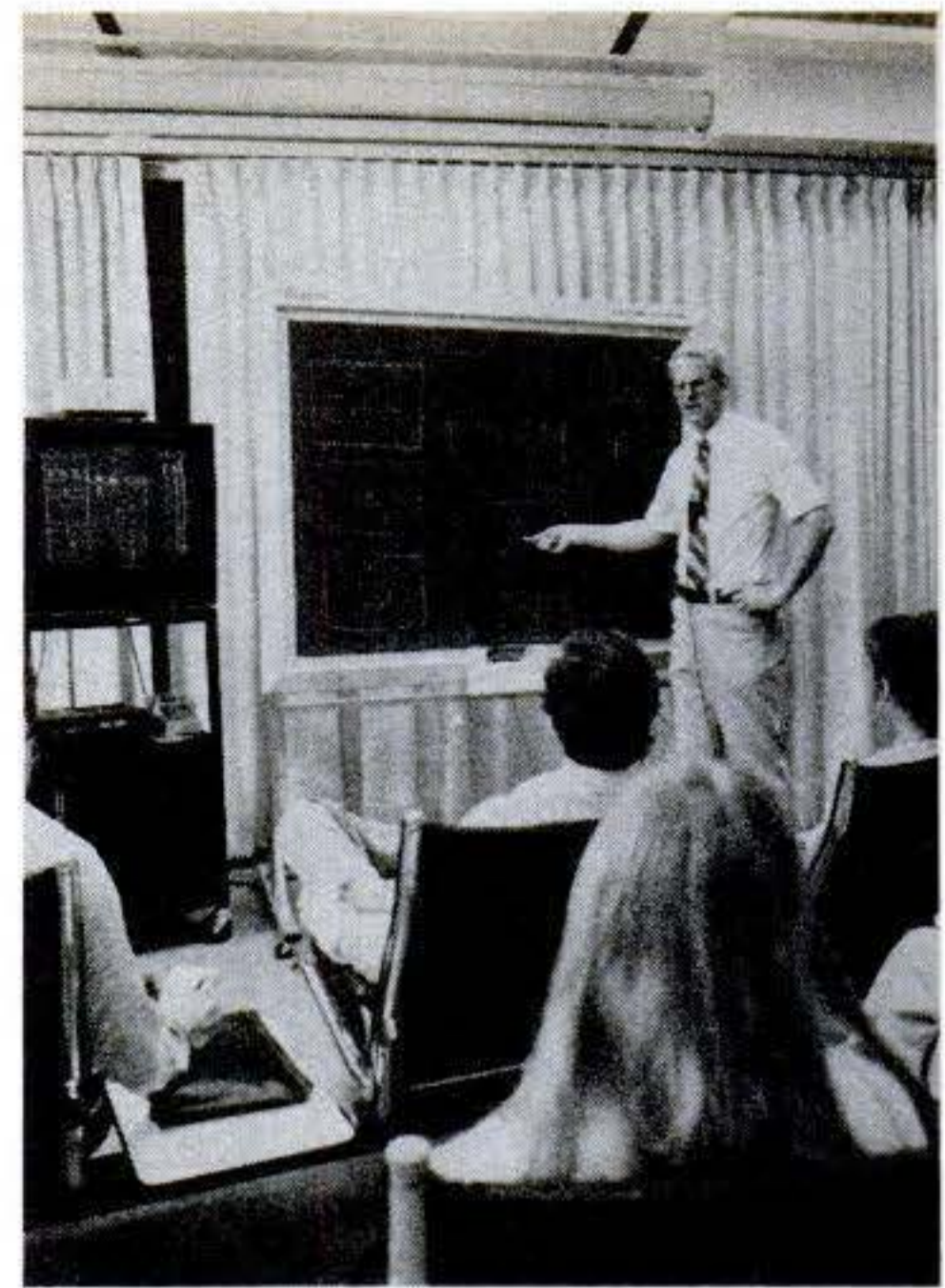

Remote blackboard broadcasts lessons

Teaching has come a long way from the little red school house. Now an electronic blackboard system can transmit a teacher's lessons to remote classrooms—and students—via standard telephone lines. Ordinary chalk is used to write on the Gemini 100 board, which consists of an aluminum honeycomb sandwich faced by two closely positioned sheets of plastic. The sheets are coated with electrically resistive material, and contact between them generates voltages that represent the position of the chalk. Thus the teacher's writing is translated into a digital code. Electrical pulses travel via phone lines to a video monitor at the receiving end.

The package includes a separate conference telephone line that permits two-way talk. Information can be broadcast simultaneously to any number of locations, and if the recipients have a blackboard of their own, they can write back to the teacher.

Erasing is easy: A felt eraser removes mistakes as they are made, or the entire program can be "cleared" at the push of a button. Lessons can be recorded for future use, and a photocopy machine can provide copies within 20 seconds of transmission. The unit also comes with a series of self-testing features to trouble-shoot mechanical problems. Public-utility commissions nationwide have agreed to make the board available through local phone companies, says Andy Myers of Bell Labs Research and Design.

Costs vary, but \$450 per month to lease a send/receive station is average. Western Electric Co., 222 Broadway, New York, N.Y. 10038.—Jane Kleintob

PS | What's News

When I first saw the drawings of the transmission shown on our cover, I spent a lot of time trying to figure out how it works before I read the description. Tracing the power flow through led me down several blind alleys until I finally gave up and read how it works. As understanding slowly seeped in, I was struck by the fiendishly clever way the designer had solved some of the stubborn engineering problems that have plagued previous designs of continuously variable traction-drive transmissions.

If you have trouble grasping the operation at first, I suggest a little experiment: Put a thread spool on a stick and roll it around the inside of an embroidery hoop held stationary. Note the motion of the spool, your hand holding the stick, and the force you apply to maintain rolling contact between the spool and the inside of the hoop. Switch to a larger spool and note the difference in the speed of its rotation. Now you have observed the fundamental elements of this transmission. All the designer of a practical transmission has to do is find how to get the input torque to the stick, deliver the output torque from the spinning spool, and develop enough force to hold the spool in contact with the hoop's inner circumference. Cones are the obvious choice to get the variable diameter. But how do you maintain contact at different diameters? Tilt the shaft on which the cone turns. How do you develop enough force of contact? Add an opposing cone to wedge the two apart—and you get a bonus from the centrifugal force as the shaft nutates. If that word *nutate* is unfamiliar, the concept is simple: It means the nodding motion of the rotation axis of a spinning body. You've seen the action in a toy top wobbling as it slows. Sharp-eyed readers, incidentally, will notice that the simplified schematic drawing on the cover is slightly different from the one shown in the article (page 85). These are two of several variations possible in the gear arrangement.

Geothermal energy gains

Most of the readily available geothermal energy is in the form of fiercely corrosive hot brine ["Geothermal goes East," PS, Feb. '79]. Devising efficient heat exchangers to extract energy without becoming clogged or eaten away in a short time is a major problem that must be solved before

widespread use of the abundant heat from the earth can be put to work. Under contract to DOE, the engineers at Barber-Nichols Engineering Co. have taken a novel approach: They've eliminated the conventional tubes and shell of heat exchangers so there is no dividing wall between the hot brine and the working fluid to accumulate scale or corrode. They claim to have designed the world's first direct-contact geothermal power plant. It is a proof-of-concept pilot that can generate 500 kW. The key to this hot idea is the liquid you put in your cigarette lighter, isobutane. They put liquid isobutane into the base of a 35-ft.-tall tank containing hot brine. Droplets of isobutane rise through the hot brine, absorbing heat as they rise and vaporizing in the last two feet. The isobutane vapor drives a turbine.

Under another DOE contract, engineers at Sperry Corp. are trying a different approach to geothermal energy conversion. They place a pump, coupled to a small turbine, deep into a hot-brine well—perhaps 2000 feet down. The pump draws a working fluid such as Freon into the well, where the heat transfer from hot brine to working fluid takes place. The Freon, now under pressure, is piped back to the surface where it drives a turbine, is condensed, and returned to the well.

Popular Science on the air

You may already have heard them in your area: short daily radio programs on noteworthy scientific and technological news written and delivered by the editors of POPULAR SCIENCE. The programs, called *Discovery*, began in January in most areas, and are now heard daily on some 300 radio stations around the country. Coverage is expanding each month, so if they're not yet in your area, keep listening.

Utilities pay their customers?

An odd thought, but for some customers it could become a reality. According to a news report, Wisconsin Electric Power will pay customers who generate more electricity from windmills or small hydroelectric installations than they can use, when that excess is fed back into the grid. A spokesman for Wisconsin Electric said, "We need to use every available energy source. . . . We particularly want to encourage alternative energy forms."

Devices such as Hans Meyer's Gemini system [PS, Oct. '75, p. 50] make it possible and practical. There has been much talk about selling excess electricity back to your utility, but Wisconsin Electric's announcement is the first I have heard of in the U.S. where a utility has set a policy and a rate for buy-back. If other utilities follow their lead, it could make a wind generator or a small hydroplant a much more attractive investment.

One-gun color TV tube

On the cover of the February 1972 issue of POPULAR SCIENCE was an illustration of a remarkable new kind of color TV picture tube. It had no complicated, finicky, and expensive shadow-mask. It used only one electron-beam gun instead of the usual three. Our reporter who witnessed laboratory demonstrations was impressed with the bright, sharp, full-color image. The tube, called *Uniray*, was invented by a Philadelphia engineer, David Sunstein. We expected one of the big U.S. TV manufacturers to grab the invention, develop it, and put it into production. We heard nothing more until recently, when I read that National Panasonic has developed a new type of color TV picture tube. The description of this tube is almost exactly like the one we reported on in Feb. '72. In Germany, National Panasonic has demonstrated portables with 12-cm tubes, which, according to the report, are ideal for battery-powered TV because they consume much less power than the conventional three-gun tube.

Sewer gas fuels cars

They are fueling five city vehicles with methane from sewer gas in Modesto, Calif. [PS, June '77]. The city's sewage-treatment plant processes about 23 million gallons of sewage a day, which gives off more than 200,000 cu. ft. of sewer gas—about 70 percent of it methane and wasted. Compressing the cleaned methane and burning it in modified city vehicles, the city is getting fuel at an estimated cost equivalent to gasoline at 30 cents a gallon.



Editor-in-Chief

Colliding-beam accelerators

— will they reveal the ultimate particles?

Giant, high-energy devices can help reveal the forces that bind matter together

By PETER GWYNNE

GENEVA, SWITZERLAND

The security guard studied our passes carefully.

I was sitting in a car with engineer Vince Hatton at the entrance to a tunnel in the spacious grounds of the Centre Européen pour la Recherche Nucléaire, known universally by its acronym CERN, in Geneva.

Despite its title, CERN has nothing to do with nuclear power. It is a center for the study of high-energy physics, the science that reveals the fundamental basis of matter. The security guard who stopped us was more concerned with checking passports than flushing out terrorists. For after he approved our papers, and Vince drove the few hundred yards through the tunnel, we emerged in France. CERN and its huge accelerator known as the Super Proton Synchrotron (SPS) stretch across the boundary between Switzerland and France, and the special tunnel allows scientists to move themselves and their equipment easily within the installation without having to pass through the passport and customs posts above ground.

Improbable as the idea of a particle accelerator located in two countries may sound, it is no more unlikely than physicists' plans for the huge ring-shaped machine. Within three years, they expect to inject into it two beams of elementary particles that will whirl around in opposite directions at almost the speed of light, and then crash into each other time after time at six "crossing points" inside the ring. It's

rather like asking William Tell to fire his arrow, not at an apple, but at another arrow already in flight.

Twentieth-century monuments

The CERN scientists aren't working in isolation. Engineers are refining or constructing multimillion-dollar particle-collision machines at locations ranging from Stanford, Calif., to Hamburg, West Germany. Buried up to 40 feet underground, the machines will eventually appear to latter-day archaeologists as monuments to man's search for the underlying secrets of nature, just as the ancient stone circles dotted across Ireland testify to the early Celts' quest for spiritual perfection.

Everything about the particle accel-

erators is strictly twentieth century. Swathed in brightly painted magnets, the circular cavities that actually carry the particles extend up to four miles, inside tunnels 10 feet tall. Connected to the tunnels are smaller rings that generate the particle beams, and cavernous experimental halls filled with bubble chambers, magnetic detectors, and other huge devices that monitor the beams' catastrophic crashes. In brightly lit control rooms, engineers order up real-time data on the beams' behavior on banks of television screens, and order changes in response to computer-controlled alarms.

The purpose of the effort is profound. By monitoring and examining the subnuclear particles that emerge



Control rooms at the Super Proton Synchrotron CERN installation in Switzerland

will help researchers monitor proton/anti-proton collisions in 1981 tests.

from the collisions between the beams, physicists hope to learn more about the fundamental nature of matter and the four forces (gravity, electromagnetism, and the weak and strong nuclear forces) that govern the universe.

The new accelerators will subject elementary particles to greater forces than any previous manmade machines and will almost certainly, say physicists, reveal fresh and totally unexpected insights into what matter really is. "Historically, every time we've had a new energy region to investigate, we've seen more of the peculiarities that weren't observable before," Phil Livdahl, of the Fermilab National Accelerator Laboratory outside Chicago, told me.

Stretching technology's limits

Attaining the ultrahigh energies requires technological inspiration and achievement of a high order. Engineers and physicists building the new machines are pressing old technology to its limits—and designing new technology that hasn't yet been tested. New methods of focusing pencil-thin beams of particles, fresh ways of creating ultrahigh vacuums, and totally untried superconducting magnets operating at temperatures close to absolute zero are among the ingredients that will mean success or failure for the new wave of particle accelerators.

The very idea of crunching two beams of particles together contrasts with the more traditional designs of atom smashers. In the past, experimenters shot high-speed, high-intensity beams of protons, electrons, or other particles into solid metallic targets, and monitored the new particles produced by the bombardment. But that process is rather inefficient. The beams use up most of their energy in pushing back the targets. Only a small proportion remains to create the fresh forms of matter that provide tantalizing clues to the basic structure of nature.

At Fermilab, for example, the giant accelerator, two miles in diameter, creates beams of protons with energies of 400 GeV. (GeV stands for giga electron volts, or billions of electron volts. If one billion electron volts of energy were all transmuted into matter, it would produce enough mass to make a proton.) But when the Fermilab beam smashes into its solid target, only 28 GeV is actually available for forming new particles.

Colliding-beam machines, by contrast, work with total efficiency. When two beams collide almost head-on, all their energy goes into creating new particles. So a relatively small

machine that imparts just 15 GeV to each of two colliding beams of particles causes collisions involving 30 GeV of energy—more than the monstrous Fermilab device produces with its fixed targets. And as the amount of energy in the beams increases, so do the chances that their collisions will produce the rare and unusual new particles that physicists seek. "There's a whole new domain of research to come out of this work," Italian physicist Carlo Rubbia told me at CERN.

The machine builders, and the scientists who will design experiments for the machines, know that they are in a race for glory. The major target for the colliding-beam machines is a particle called the intermediate vector boson. Theoretical physicists think that the particle—or a series of three or more similar particles—is responsible for the weak nuclear force that is involved in some types of radioactive decay. By detecting the so-far-unseen particle, and learning its physical characteristics, the accelerator users could confirm once and for all the theory that won the 1979 Nobel

“Historically, every time we've had a new energy region to investigate, we've discovered more peculiarities.”

prize in physics. That theory, devised by Steven Weinberg and Sheldon Glashow of Harvard, and Abdus Salam of Imperial College, London, among others, links the weak nuclear force and the electromagnetic force. It predicts that the intermediate vector boson should emerge at energy levels within the capacity of most of the new colliding-beam machines.

Of course, high-energy physics involves much more routine work than spectacular discoveries. Nevertheless, the big finds delight both scientists and administrators. "If CERN can pull off something like that every so often," CERN director John Adams told me, "it improves the faith of the politicians in us."

The politicians need to have faith because colliding-beam accelerators cost plenty—and the taxpayers pick up the tab. Among the major machines now under construction, Stanford University's positron-electron project (PEP) comes in cheapest—at \$78 million. The ambitious double-

ringed Isabelle (for Intersecting Storage Accelerator) at Long Island's Brookhaven National Laboratory carries a price tag of over a quarter of a billion dollars.

All the new machines share basic principles and ways of working. Experiments will take place in four stages: injection, acceleration, collision, and detection.

First comes injection. The two thin beams, normally generated in smaller atom smashers, are fired into the accelerators' main ring or rings. The rings, a few inches in internal diameter, are surrounded by magnets and located in spacious tunnels through which technicians can drive as they trouble-shoot problems. In most cases, the beams will consist of bunches of particles no more than a few feet long. Isabelle engineers, however, expect to generate continuous beams that will girdle each ring in their mammoth machine.

Next, acceleration. The magnets around the tubes will accelerate the beams from starting energies of a few tens of GeV up to hundreds of GeV, while keeping the beams sharply focused.

The job takes two different types of magnets. Dipole magnets (which, as their name implies, consist of a north and a south pole) accelerate the beams and bend them around their ring-shaped tracks. Quadrupole magnets, with two north poles and two souths, prevent the beams from splaying out to hit the sides of the tubes.

Most machines use three or four dipole magnets for each quadrupole—and the largest accelerators require truly spectacular numbers of magnets. The SPS at CERN, for example, contains 744 dipolar magnets and 216 quadrupoles; Isabelle will carry more than one thousand magnets when it's completed in the middle 1980's. The magnets will force the beams to make billions of revolutions each day.

Subnuclear rumbles

Once the beams are traveling sufficiently fast and energetically, they will smash together. Engineers using computer controls will force them to collide at anywhere from one to six regions around the rings. The head-on crashes will occur over regions up to two feet long and minute fractions of an inch thick—about the diameter of pencil lead.

Finally, complex instruments costing up to \$14 million apiece and weighing perhaps thousands of tons will monitor all the particles created by the subnuclear rumbles. Directed by yet more magnets, the products of the collisions will stream out in series

Continued

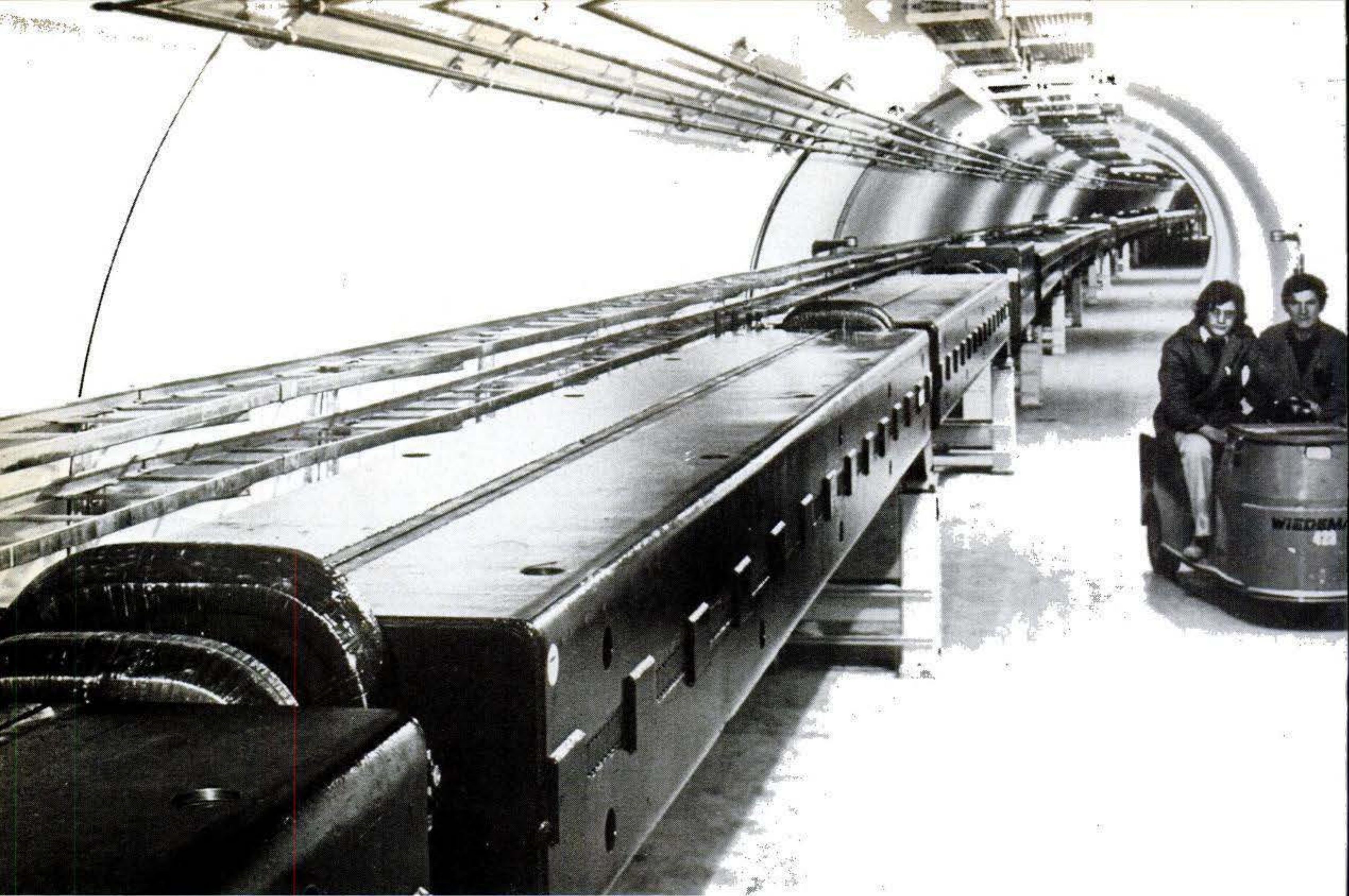

Protons and antiprotons will speed in opposite directions inside single ring in CERN tunnel that crosses national borders.

of beams into experimental halls where the detectors are mounted.

For all the basic similarities, no two colliding-beam machines are alike. They use different particles, different levels of energy, and different types of magnets to achieve their goal of contributing to high-energy physics—and making the significant finds before their rivals.

Machines that bring together beams of electrons and positrons (the latter being, in effect, electrons with positive, instead of negative, electric charges) have proved quickest off the mark in the high-energy physics stakes. Research teams at the Deutsches Elektronen Synchrotron, known as DESY, have already made some notable discoveries with their \$52 million PETRA collider, which slams beams with 19 GeV of energy into each other. Scientists started injecting beams into a segment of Stanford's PEP, which resembles PETRA, last fall—although the ring remains incomplete. At Cornell University, project head Boyce McDaniel reported that the new Cornell Electron Storage Ring (CESR) "has given very encouraging results" in its early tests.

Because it's difficult to accelerate electrons, none of those machines generates enough energy to produce the long-sought intermediate vector bo-

son. That task will fall to a collection of huge accelerators using protons, which come on line within the next half-dozen years.

Scientists at CERN will undoubtedly take the first crack at the task. They are adapting their Super Proton Synchrotron, which presently slams a single beam of protons into fixed targets, to accept a second beam of antiprotons—the particles whose fundamental properties are the exact opposite of those of protons. "The hardware for the proton-antiproton experiment should be ready by 1981," said John Adams. "Then," he added confidently, "it's just a matter of time before we see the intermediate vector boson."

U.S. labs giving chase

But technical difficulties, scientific problems, or just plain bad luck could throw off that schedule. The teams at Brookhaven and Fermilab haven't yet given up the chase, although they expect that their machines will be competing with CERN's to see unexpected new finds rather than the elusive intermediate vector boson. "It's clear that if Isabelle were coming in two years earlier, CERN wouldn't have such an opportunity," lamented Brookhaven physicist Nick Samios.

Isabelle has certain advantages. For a start, it will slam protons into

other protons, unlike any other large machine on the drawing board. And the two beams will each possess 400 GeV of energy—appreciably above the 270 GeV per beam planned for the CERN collider and the 80–100 GeV believed necessary to detect the intermediate vector boson. Why such a margin of error? "We chose 400 by 400 because we distrust our theoretical friends," Samios confided to me.

Even Isabelle won't be the most energetic colliding-beam machine. That honor will go to Fermilab, which hopes to use a new ring now being installed with superconducting magnets to cause crashes between a beam of protons and another of antiprotons, each carrying an astonishing 1000 GeV of energy. "1984 would be a reasonable date for start-up," Fermilab scientist Alvin Tollestrup told me.

Energy isn't everything in high-energy physics, though. Experimenters try not only to make things happen at very high energies, but also to make enough things happen that their instruments will detect the events. The secret is to squeeze as many particles together in the thin regions in which the beams collide. Physicists have coined the term "luminosity" to indicate the number of individual collisions between individual particles in two beams meeting head-on, and ma-

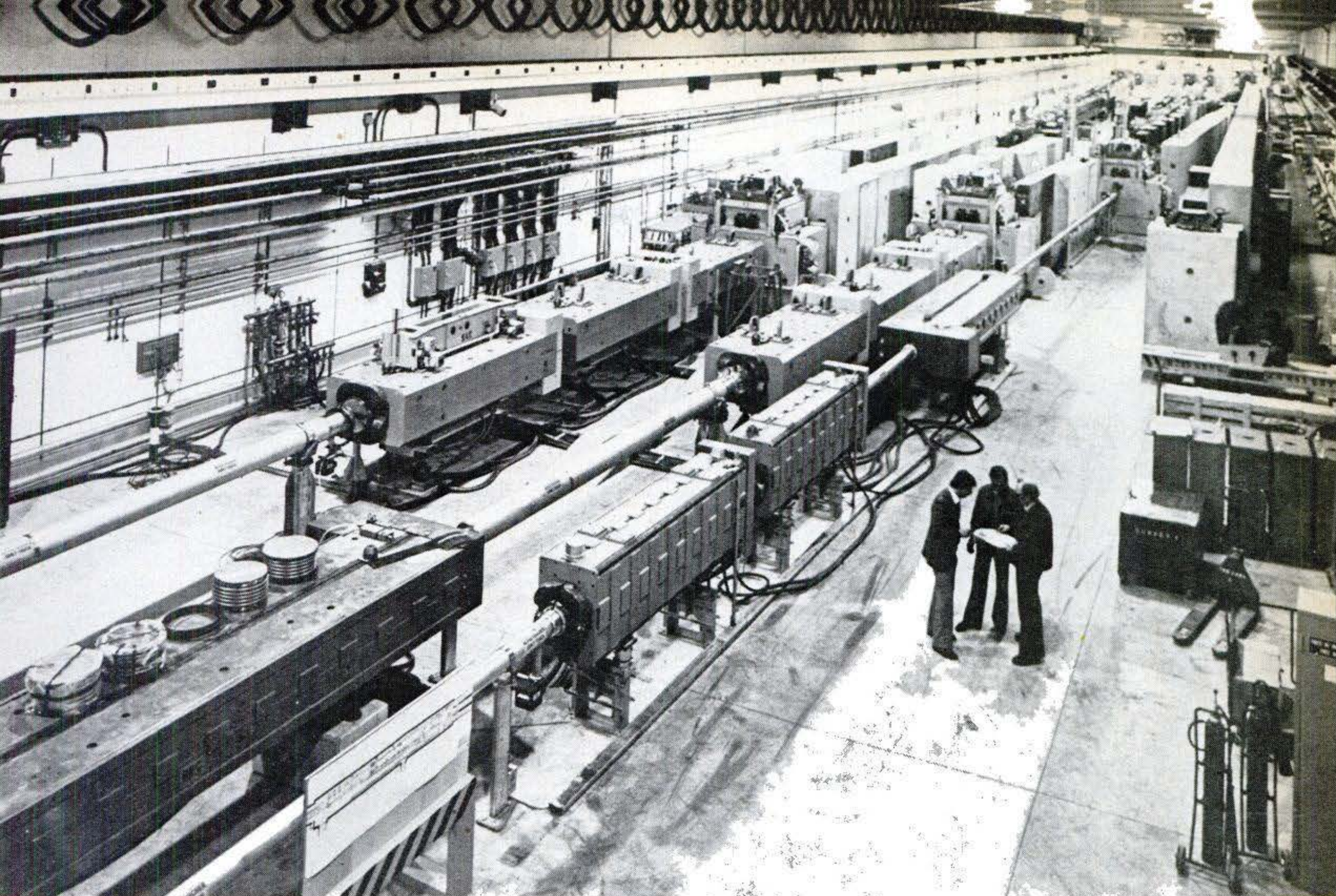

Injection point at CERN Super Proton Synchrotron is where subnuclear particles are fired into the main ring of the accelerator.

chine designers try to raise the luminosities as high as possible. "If you're looking for a needle in a haystack," project leader Jim Sanford explained as we drove around the 2¼ miles of land excavated for Isabelle, "it helps to have several needles."

When completed, in about 1986, Isabelle will create more needles than any other colliding-beam device. Experts expect its luminosity to reach 10^{33} —that's one followed by 33 zeroes—collisions per square centimeter per second. The figure represents an increase of one thousand over the luminosities forecast for the CERN and Fermilab colliders, and outscores the electron-positron machines by a factor of ten.

Scalpels vs. sledgehammers

Electron-positron machines have their own unique advantages. Because both particles are truly fundamental and indivisible, collisions between them tend to yield relatively small numbers of easily detected new particles. Protons and antiprotons, by contrast, have their own substructure; theorists think that they each consist of three of the elementary particles called quarks, linked together by evanescent particles known as gluons. Thus a crash between a proton and an antiproton produces a huge

shower of new entities—enough to tax the most sophisticated detector. Collisions between two protons are even more productive.

Because of their particular properties, experimenters plan to use the different particles in different ways. "Electron-positron collisions are like scalpels, and proton-antiproton ones like sledgehammers," explained Nick Samios as he ran through the list of machines on his blackboard at Brookhaven. Thus physicists expect to make fresh discoveries with proton machines, and then characterize and refine the finds with electron devices. That's already happened once. In late 1974, teams of researchers at Brookhaven's alternating-gradient synchrotron, a proton machine, and the two-mile Stanford Linear Accelerator, an electron device, simultaneously spotted a particle that became known as the J/psi (or gypsy). Just what the particle was became clear when the Stanford researchers re-examined it with their electron machine. It plainly contained a new type of quark that had been forecast 10 years previously by Harvard's Sheldon Glashow.

One of the new electron-positron colliding machines has already notched a major achievement. Last summer, scientists working with

Hamburg's PETRA reported evidence for the existence of gluons. The cleanliness of the collision between an electron and a positron made the discovery possible. When those two particles collide, theorists believe, they annihilate each other, converting all the matter into a great burst of energy. Almost immediately, new particles emerge from the cloud, in the form of two quarks. The creation of the pairs of quarks manifests itself as small jets of particles emerging from the collision region as the quarks quickly change into other, more identifiable, particles. Instead of two such jets, however, the PETRA researchers spotted three. The most likely reason: The third jet represented the breakup of gluons, which linked the pairs of quarks produced in the head-on collision.

The thrill of new discovery has eluded other centers of large colliding-beam machines so far. Their engineers face the more mundane concerns of getting the machines to work. Stanford University's PEP has encountered the most irritating problems. For while new accelerators have a long tradition of starting up earlier than scheduled and coming in under their budgets, PEP is costing more and moving more slowly than expect-

Continued

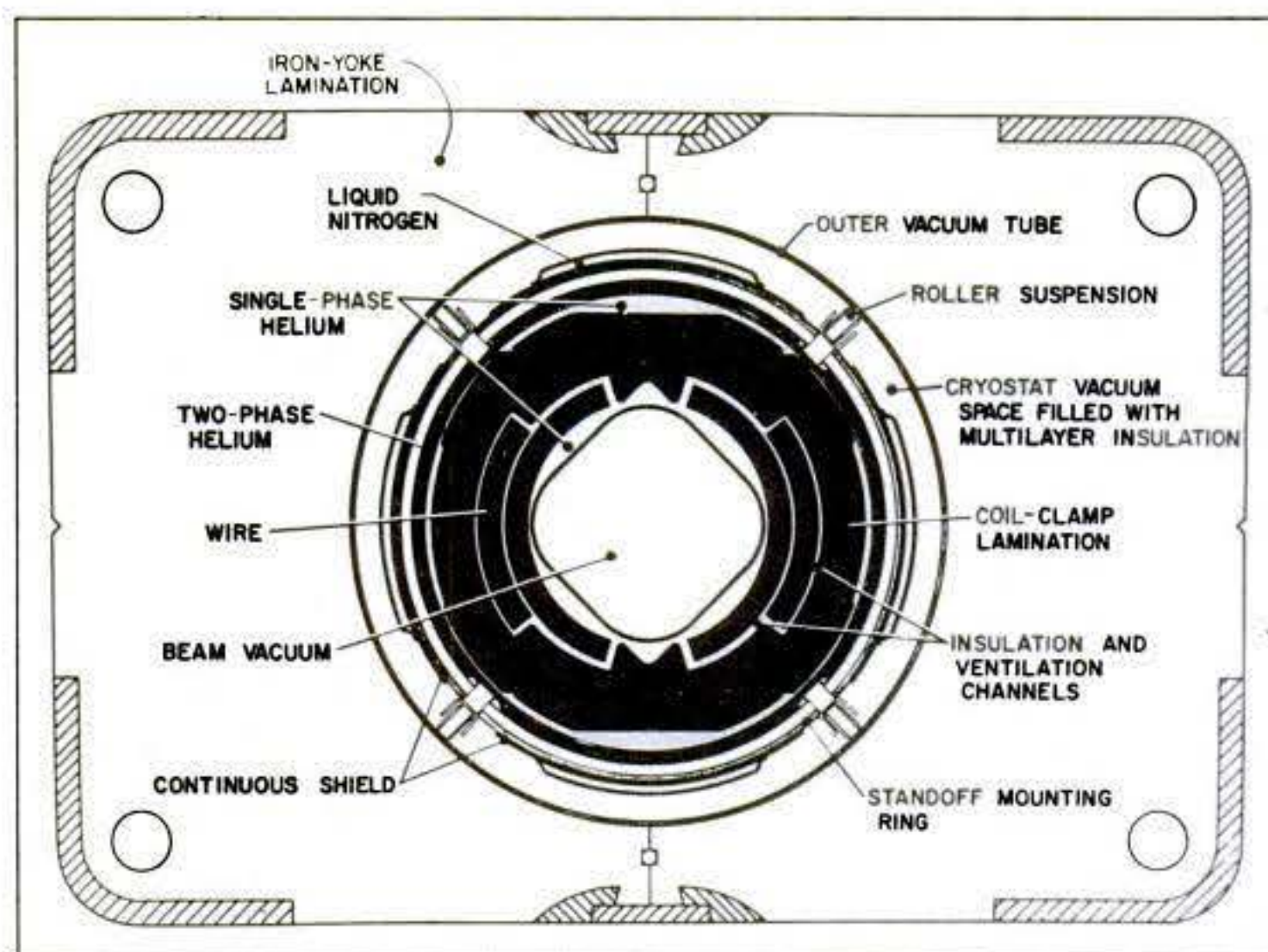

Superconducting accelerator being installed at Fermilab is more compact than 400-GeV accelerator above it (left). Diagram shows the complex cooling needed for superconducting magnets.

ed. Engineers expected to run the first beam around the PEP ring last October. Now, they say, that won't happen until March.

Difficulties and delays

John Rees, who heads the project, lays the blame squarely on American industry. "The vendors are performing in a way that, 20 or 30 years ago, I'd have said was scandalous," he complained when I toured the still incomplete facility. "There are firms that take advantage of the fact that we're virtually required to take the low bidder. They bid low to get the job, and then try to improve their profit by claiming in court that the conditions of the contract have been changed."

Rees complains mainly about well-established technology, such as electrical installations. So it's not surprising that engineers developing entirely new technology for their machines have also encountered difficulties and delays.

The main challenge is to produce superconducting magnets. Both Fermilab and Brookhaven have opted for this brand-new technology, because it reduces the amount of power required to create the colliders' magnetic fields by up to 80 percent. But the technology is so novel that it's scarcely out of the laboratory. "You start from scratch, and you don't understand anything," commented Fermilab engineer Tim Toohig.

Both laboratories face problems with their superconducting magnets. At one point, the factory at Fermilab had produced 100 magnets, but could use only 12. Brookhaven had to set up its own magnet factory after industry proved incapable of making the magnets. Even its own products aren't up to standard. They seem unable to generate magnetic fields higher than 40 kilogauss. Unfortunately, plans for Is-

abelle require the magnets to generate 50 kilogauss apiece—100,000 times the Earth's magnetic field. "The magnets don't respond in a predictable manner day in and day out," Jim Sanford told me as we watched technicians wind coils for the magnets to tolerances of a millimeter.

Keeping the magnets frigid enough to operate as superconductors puts engineers in cold sweats. Every one of the more than a thousand magnets ringing Isabelle and the new Fermilab ring must be bathed in liquid helium to keep it within a few degrees of absolute zero, 273 degrees Celsius below freezing. "It turns out that refrigerators of the sort we need, working seven days a week under remote control, just don't exist," shrugged Tim Toohig. So Fermilab has jury-rigged a system with a huge central refrigerator that pumps an astonishing 1057 gallons (4000 liters) of liquid helium per minute—a machine that they picked up as surplus from Vandenberg Air Force Base—complemented by 24 smaller refrigerators installed in buildings around the giant accelerator ring.

Administrators at CERN avoided such headaches when they decided to use conventional magnets for their Super Proton Synchrotron, which carried its first beam of protons in May 1976. But they now have to rely on the ingenuity of their scientists to make the spectacular machine into a colliding-beam accelerator.

The problem, shared with Fermilab, is how to create and focus beams of antiprotons. Unlike protons and electrons, these particles can't be easily generated in large numbers.

Both laboratories plan to make their antiprotons by smashing beams of protons into targets, and then feeding the small number of antiprotons that result into a storage device called

an accumulator. In addition to holding the particles until sufficient numbers have built up to feed into the main machine to collide with protons, the accumulators will "cool" the antiprotons—that is, squeeze them into a well-focused beam.

The experts are only just learning how to carry out the cooling. A group at CERN spent nine months last year refining a technique called stochastic cooling. This is a kind of statistical trick that uses sensors to detect the positions of all the antiprotons in the accumulator, and devices called "kickers" to knock out-of-line particles back into the main beam. Fermilab has opted for another approach, "electron cooling," which involves running a beam of electrons alongside the beam of antiprotons. By removing some energy from the antiprotons, the electrons straighten out the antiproton beam.

Particle riches

The technological headaches will undoubtedly continue for many years. But once the machines start up, a surge of scientific discoveries will provide perfect analgesics. Physicists will start probing an entirely new region of nature, with only a hazy idea of what they will find there. Beyond the intermediate vector boson may come entities called Higgs particles, predicted by theories that unify the forces of nature. Studies of cosmic rays indicate that extraordinarily energetic particles may exist within detection range of the new machines. In fact, the greatest surprise to physicists would occur if the colliding-beam machines fail to turn up any surprises. The experts uniformly assume that a whole world of new wonders awaits the new generation of atom smashers—and that there will be more than enough riches for everyone. PS

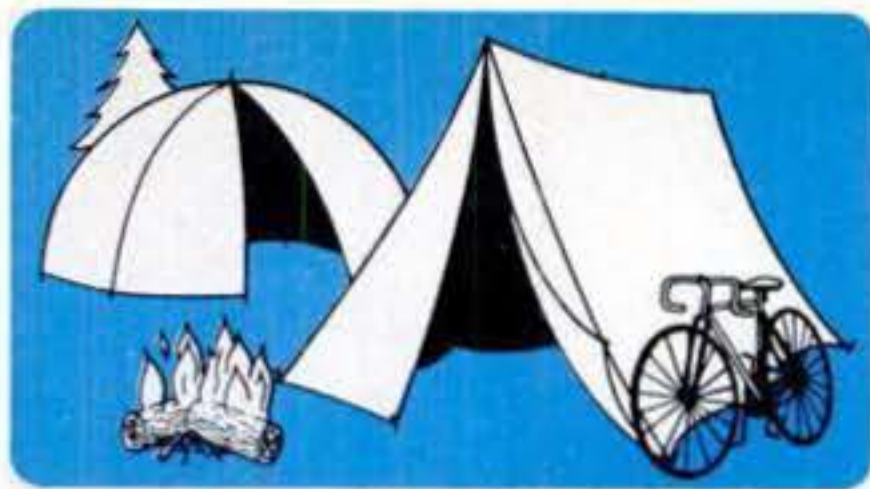

OUTDOOR RECREATION
EQUIPMENT

Back-country gear

- clever tents, packs, cookers, and more

1980's crop of camping gear sends you packing in comfort and convenience

By V. ELAINE SMAY
PHOTOS BY A. J. HAND

An all-weather sleeping bag with a built-in pad, a novel daypack that expands for overnight use, innovative carrying systems for outdoor photographers, and a smaller, lighter Coleman backpacking stove: These high-

Continued

Winterlite Gore-Tex tent (left) from Early Winters weighs 4½ lbs., costs \$295. Stargazer from Moss (center) has netting sky-

light (under fly), weighs six lbs., costs \$230. Stephenson's 2R tent is double walled, weighs two lbs., 14 oz.; \$260. All sleep two.



Versatile rucksack, the Mohawk—a daypack that grows. Unzip ends, and cover expands to hold sleeping bag. Lash on pockets, insert aluminum support stays—voila! an overnighter. Price, \$55 (\$60 with padded belt) from Tough Traveler.





Padded, waterproof camera pack holds 35-mm camera (with attached lenses up to 3½ in. long) right up front. It minimizes missed shots, yet protects camera from rain, hard knocks. Harness adjusts to fit all. Camera Pak 35 is \$25 from Tamrac.



Plenty of room for two and gear in 72-in.-wide Caddis from Eureka. Weight, seven lbs.; price, \$190. Cosmic Sleep pad from

Early Winters is ethylene-vinyl-acetate foam. Strong, supple to -94° F, says maker; 57-in. length, \$15; 73-in., \$19.

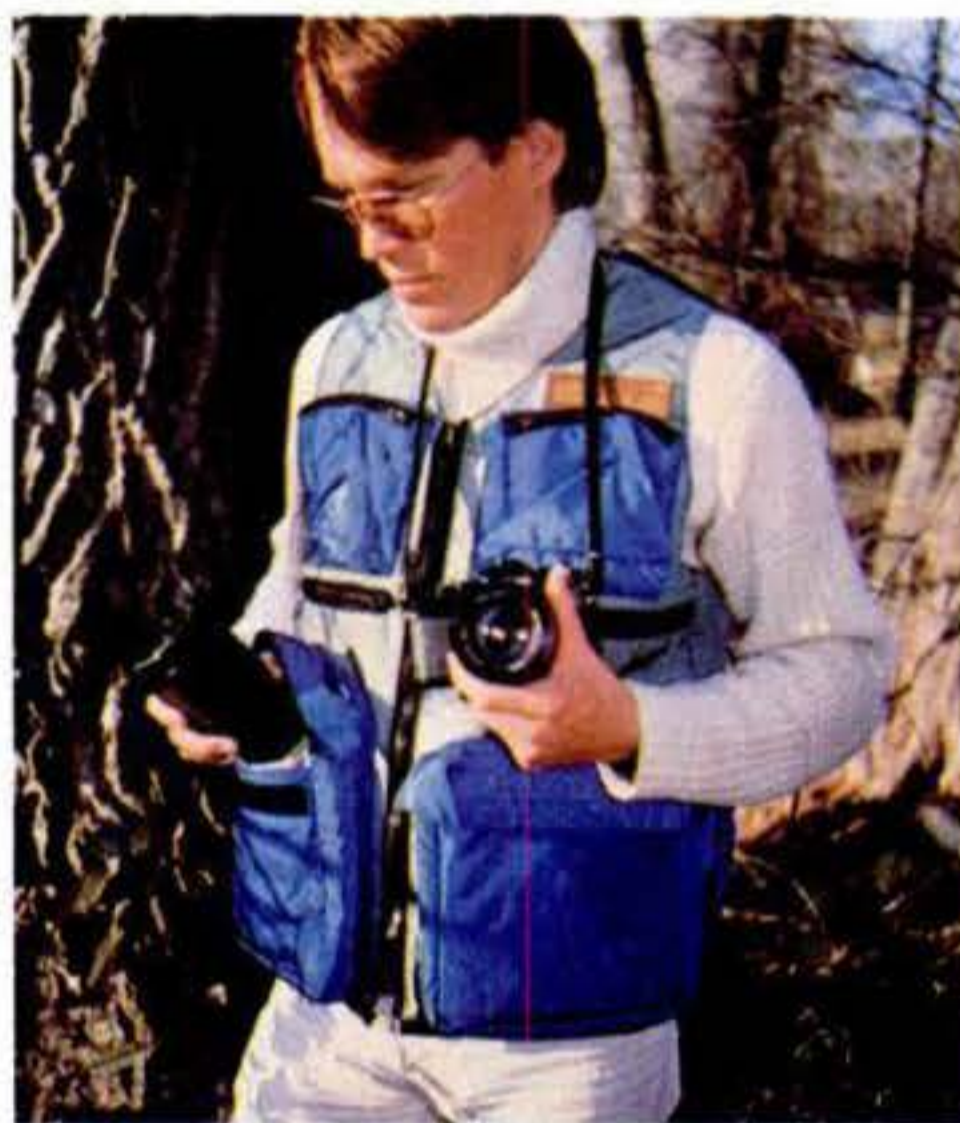

Need more than one camera and lens? Quest Vest has two padded, waterproof main pockets that can each hold two camera bodies or two 300-mm lenses. Light meters and small lenses fit in top pockets. Film pockets hold 20 rolls. Price: \$72.50.



Two-piece tent from Moss: Its poplin canopy can be used alone or with nylon tent hooked inside. Shell Canopy is \$189. Too

hot? Turn over. Thermostat bag from Camp Trails has thicker Polarguard fill in the blue side than the rust; \$95.



Go-anywhere grill, the Broil Pak, burns wood or charcoal (even paper, claims maker), weighs four lbs., folds to ½-in. thick; price, \$25. Redesigned Peak 1 stove by Coleman is smaller, lighter; fold-out legs improve stability; \$33.50. Cook/carry kit, \$12.



Tiny Tekna lights, made for scuba divers, are big help around campsite. Both are 5½ in. long. Skinny one is 1300 candlepower, weighs 3.3 oz. with two AA cells. Chubby one is 4000 candlepower, nine oz. with four AA cells. L.L. Bean: \$7.75, \$13.75.



Beech or birch? With pocket-sized "Finder" books (tree, flower, berry) by Nature Study Guild you can quickly learn. Gener-

al books are for plants east of Rockies; others are regional, as stated. Each \$1.25, eight for \$8, from Early Winters.

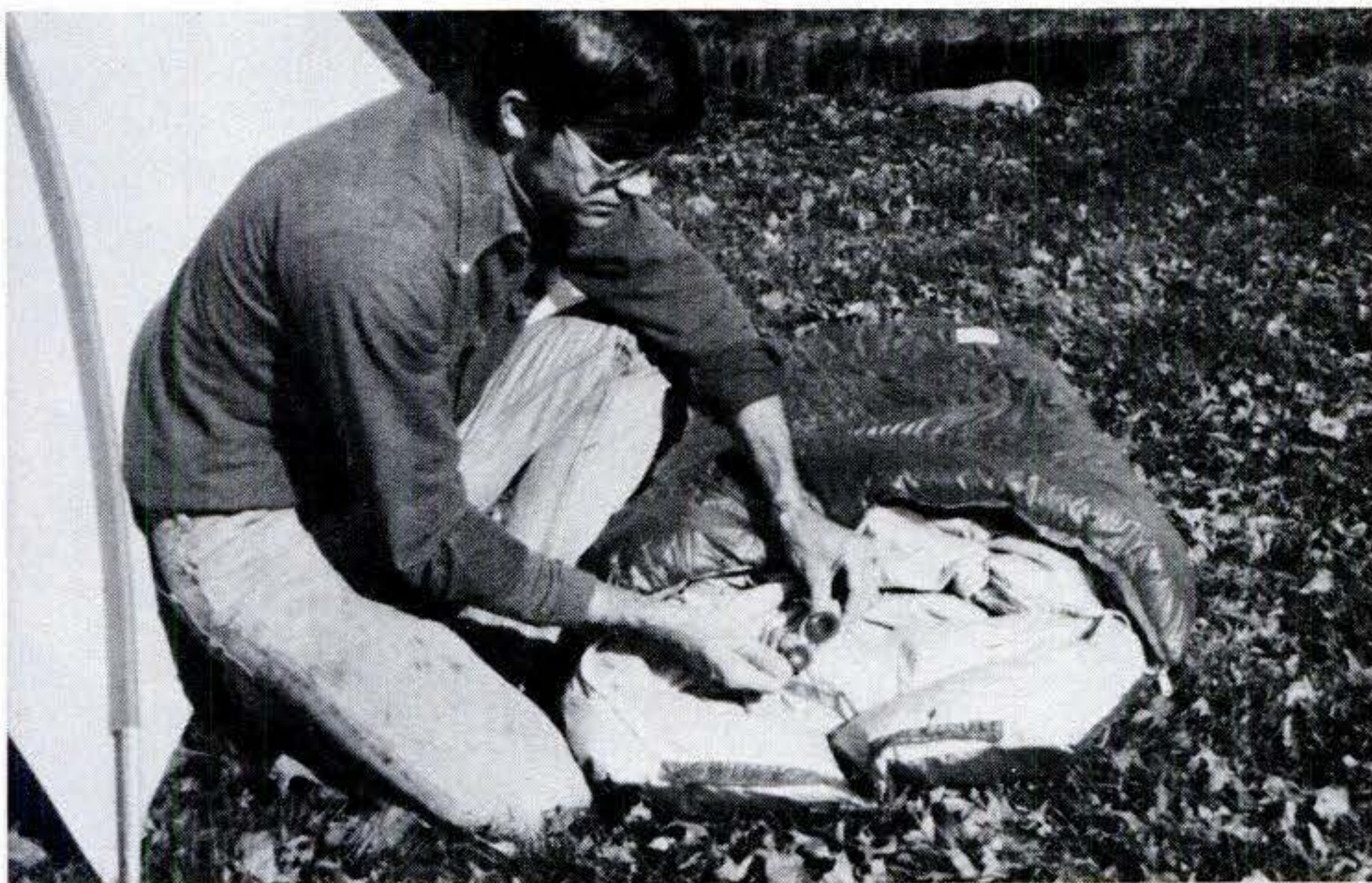

Sleeping system: Stephenson's Warmlite bag comes with down-filled air mattress (shown) or foam pad built in. Two goose-

down tops (one thicker) can be used together or separately. Price: around \$335 with pad; \$400 with down air mattress.

light 1980's collection of trail and camping gear.

And there's more: some handsome new tents, for example, four for the backpacker and one for family camping. There's a lightweight fold-up grill, two small flashlights that really are waterproof—and still more.

About the tents

The family tent in our collection, the Shell Canopy from the ever-creative Bill Moss (see "Clever Engineering Shapes New Tent Designs," PS, Oct. '77), is the first in a new series he's designing for the dawning small-car era. The canopy can be used alone, as a sun shelter, for example; then, for sleeping, a separate tent (10 by eight ft. by 27 in., with 4¾ ft. of head room) is snap-hooked inside.

The other Moss-designed tent, the

beautiful Star Gazer two-person backpacking tent, has a large netting skylight so you can look up into the sky in fair weather. In less tranquil times, just pitch the fly, as shown in our photo. The skylight also serves as a ventilating chimney: Air is drawn in through low vents along the sides, then travels up and out the skylight. The 70-by-86-inch tent pitches with just two shock-corded aluminum poles. Center height is 52 inches. There's room for two with lots of gear; three can sleep comfortably in it. Rolled size is 26 by six inches.

The other three tents shown in our photos are tunnel shaped, which gives maximum wind stability for minimum weight. These designs are also quick to pitch and take down.

The Warmlite 2R is a particularly well-engineered shelter. Designed for

use in severe mountaineering conditions, it's also suitable for the backpacker or bicyclist who needs an all-weather lightweight tent. The Warmlite comes from Jack Stephenson's small specialty works in Gilford, N.H. The main body of the tent is a double-wall structure: A breathable inner wall is spaced a few inches away from a waterproof outer wall. The cone-shape ends are formed of the waterproof fabric only. The two-wall concept reduces condensation, and the air space between the walls acts as insulation. The inner wall has an aluminum coating, which helps hold in radiant heat. Ventilation is provided by two screened intake vents close to the ground, and another at the highest point that lets warm air out. For cooling on a warm, breezy night you can zip open two side windows.

The featherweight (less than three pounds) 2R (two-person size) is 60 inches wide and 40 inches high at the front, 48 inches wide at the back, and 134 inches long. The R series is available in three- or five-person sizes, as well. Stephenson also offers ultralightweight single-wall tents, the X series, that are made of a nylon and Mylar laminate. The two-person X-tent weighs a mere 28 ounces. Jack Stephenson recommends these primarily for dry climates. "Condensation can occur in humid conditions," he explains.

The Winterlite from Early Winters is an all-weather single-wall tent. It needs no fly because it's made of breathable *and* waterproof Gore-Tex (see "New Comfort and Convenience on the Trail," PS, Mar. '78). The Winterlite has both a front and back door, each screened. It's 8½ feet long, 56 inches at the widest point, and has 39 inches of head room at front. Packed, it measures eight by 16 inches.

The other tunnel tent, the Caddis from Eureka, is especially roomy: 96 inches long, 72 inches wide at the center, 43 inches at the ends, with 43 inches of head room at the center. It, too, has a front and a back door, each screened. Its three shock-corded aluminum poles slip neatly onto ring-and-pin assemblies at each end of the catenary cuts, making setup a snap. A separate fly is anchored with Velcro.

At seven pounds, the Caddis is not a featherweight. But three could sleep comfortably in its spacious interior, and you can pack it in two bags.

Sleeping bags

The two sleeping bags in our collection are both designed to give you a choice of cover thicknesses to adapt to various weather conditions. The Thermostat, made by Camp Trails, is filled

[Continued on page 178]

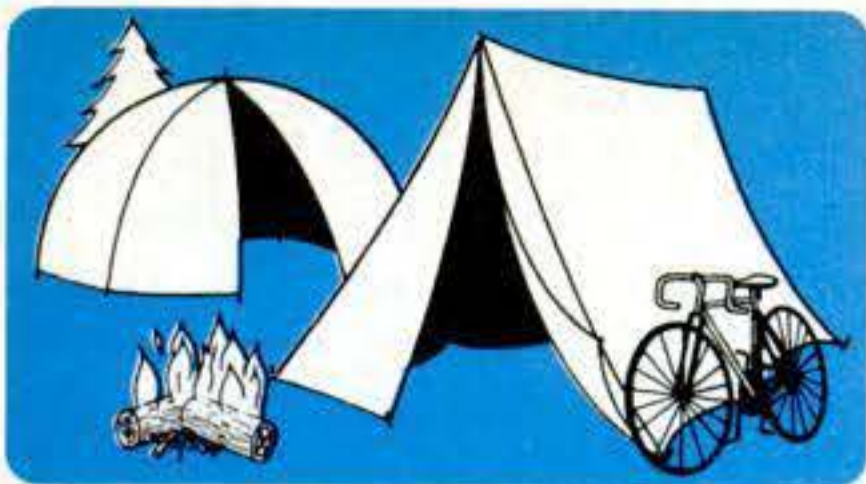

OUTDOOR RECREATION
EQUIPMENT

How to get the best buy in a 10-speed bike

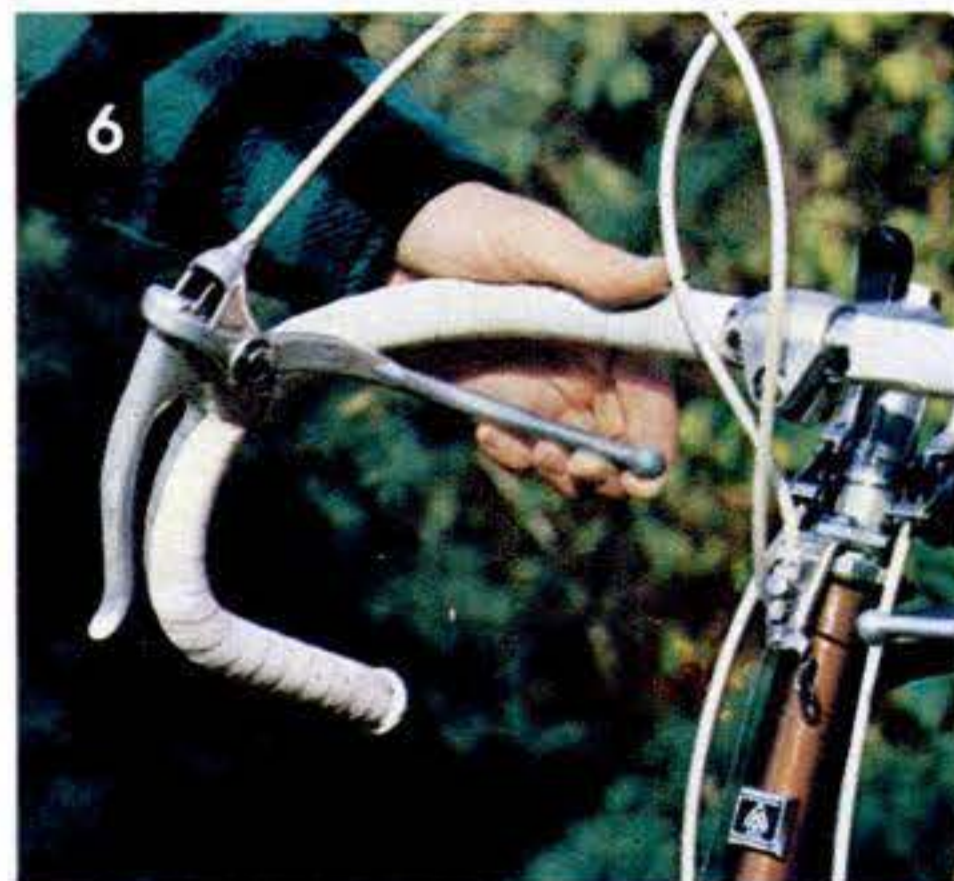

Components and features to look for: Two derailleurs shifters control which of 10 speeds you're in (1). Mounting levers on handlebar stem puts them in easy reach for most riders, but makes for longer cables, less responsive shifts. Rear derailleur (2) positions chain on one of freewheel's five sprockets. Touring derailleur (shown) accommodates wider gear ratios than racing-type derailleur. Front derailleur (3) moves chain from inner to outer

chainwheel. Alloy chainwheels, cotterless cranks save weight, yet are very strong. Number of teeth in five freewheel sprockets and two chainwheels tells you if bike is for touring or racing. Here's an example for general-purpose recreational riding or touring: a freewheel with 14-, 16-, 19-, 26-, and 32-tooth sprockets, combined with 42- and 52-tooth chainwheels. Alloy "micro-adjusting" seat post (4) saves weight and lets you carefully position height and

tilt of the seat (note Allen-wrench adjustment). Seat is at correct height when your legs are slightly bent at the bottom of a stroke. Most serious cyclists prefer shift levers mounted on down tube (5); since cables are shorter, shifting is more precise. Note chromed lugs at frame joints and brazed-on cable guide on top tube; all are signs of a high-quality bike. Many experts recommend against use of brake "safety" levers (6) because it's impossible

By **RICHARD STEPLER**

PHOTOS BY A. J. HAND

Gas crisis? It doesn't affect me when I want to get out of town. I just hop on my 10-speed and start pedaling. It's also the quickest way for me to travel from my home to the office—a mile and a half through the streets of Manhattan. Commuting by bike not only gets me there on time, but it's great exercise, too.

It looks as if I'm not the only one who feels that way. According to the Bicycle Manufacturers Assn., about 10.5 million bikes were sold last year in the U.S. Add that to the 95 million already in use, and you have a sizable bike-riding public.

Want to join the trend? A visit to your local bike shop may leave you a bit bewildered. How much should you

Continued



to apply full braking pressure with them. While safety levers are easy to reach, you should use regular levers (7) in panic situations for maximum stopping power. Alloy side-pull brakes (8) are found on top-quality 10-speeds. They're easy to adjust, weigh less than steel brakes, and are reliable. Quick-release feature (demonstrated above) lets you remove wheel fast for convenient tire repair when you are on the road.



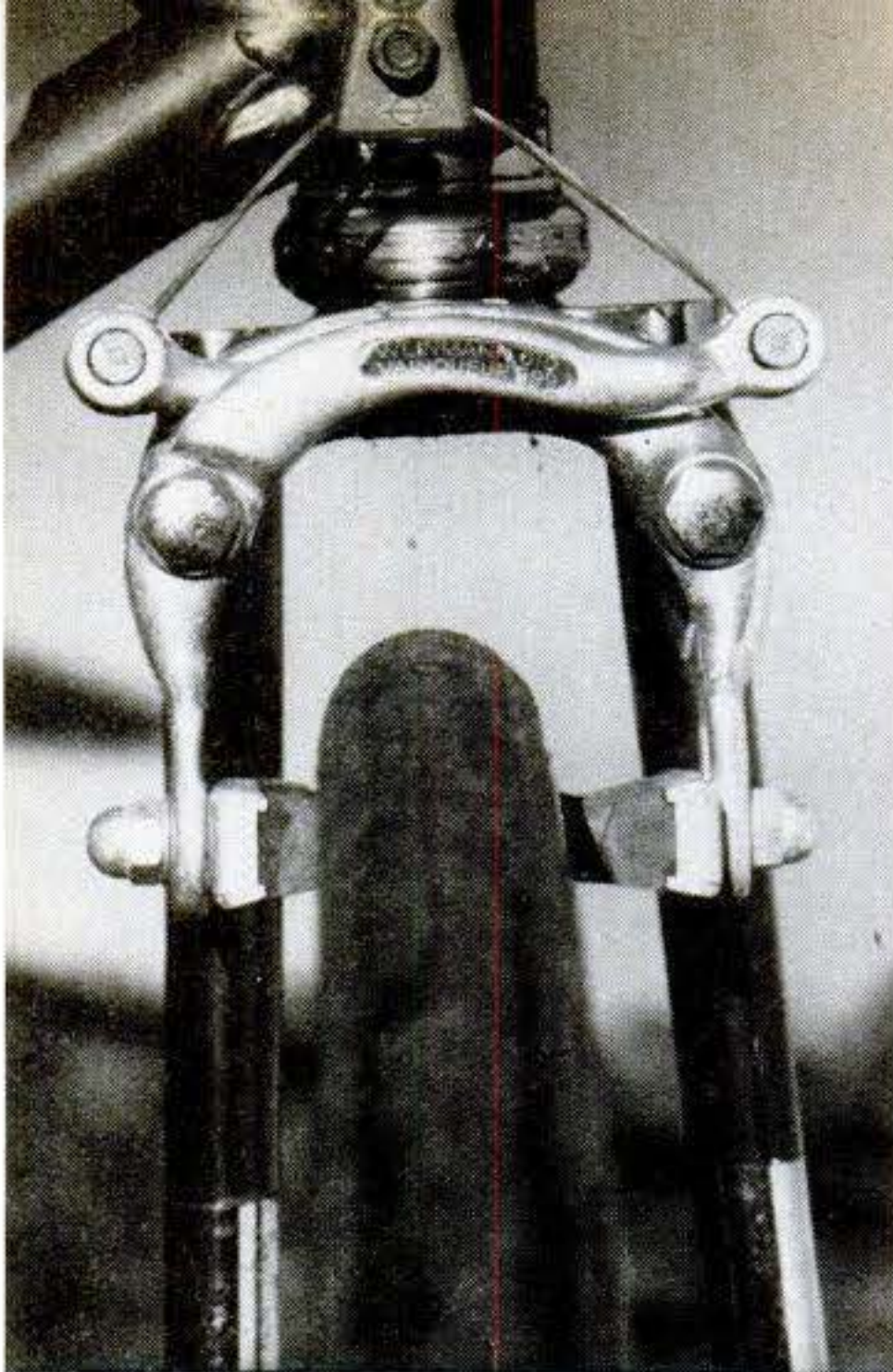

Lightweight alloy center-pull brakes are found on many low- and mid-priced 10-speeds. This type brake is easy to adjust and capable of safe, reliable stops. Brake shoe should be positioned close to rim.

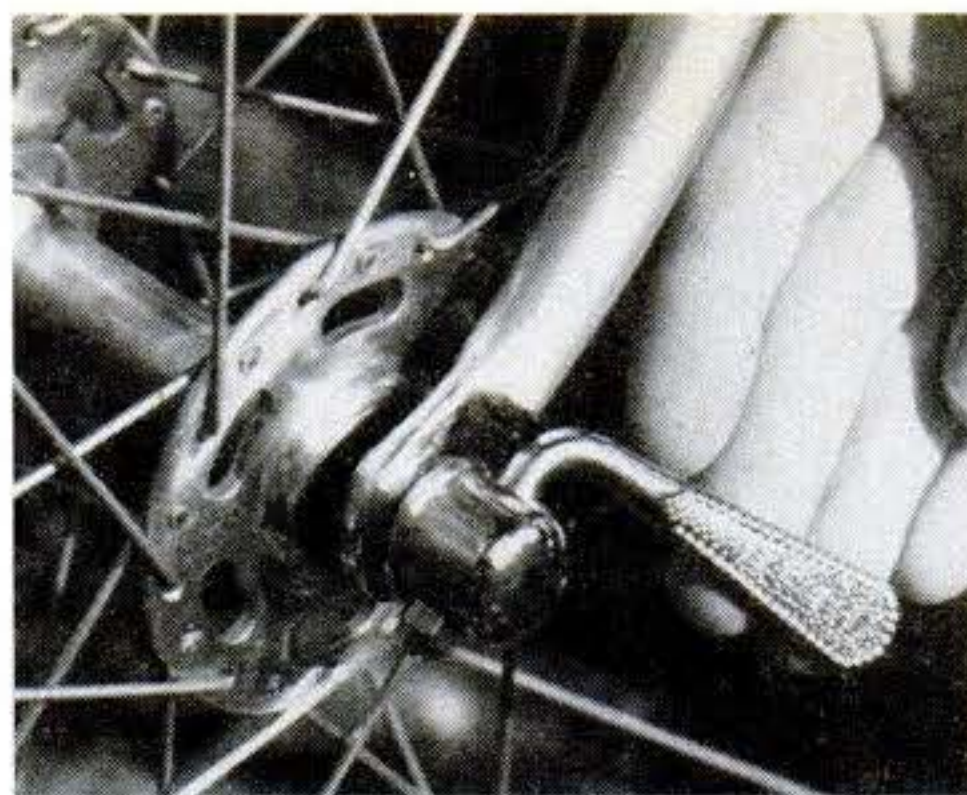

Quick-release lever on wheels lets you remove and replace them easily on the road. (Yes, be prepared for flats and carry a repair kit.) Cheaper bikes have nuts on axles, need wrench for wheel removal.

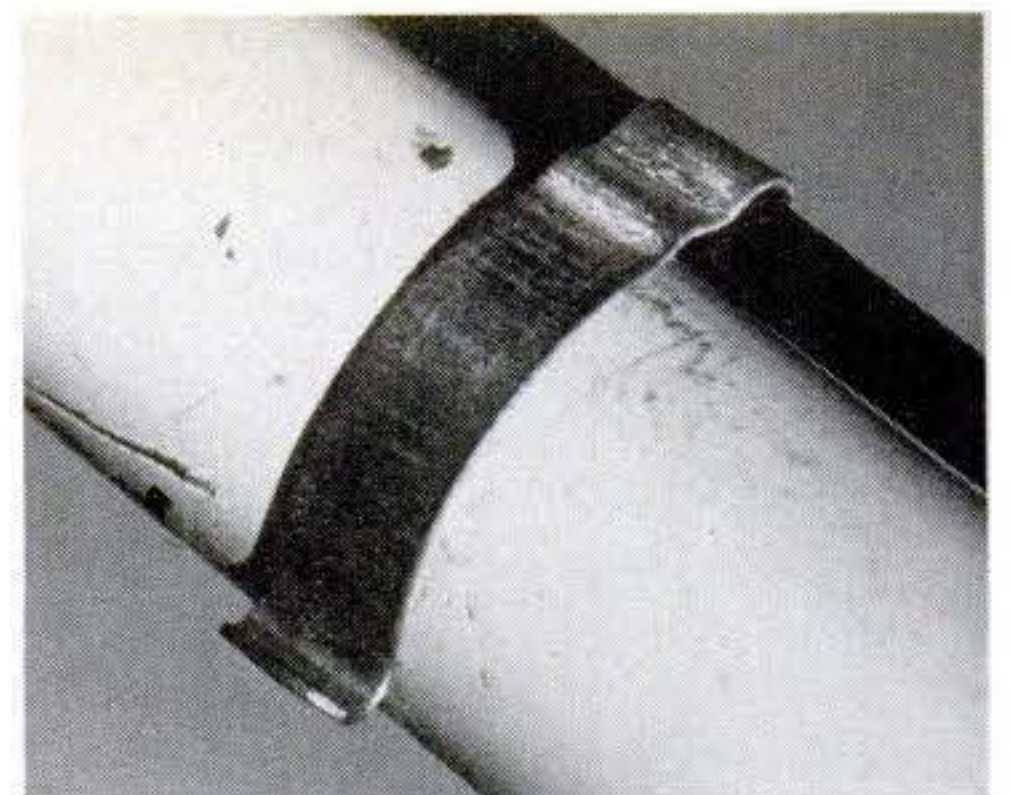

Most manufacturers use metal or plastic clips to secure brake and derailleur cables to the bicycle's frame. Brazed-on guides (preceding page) look neater, won't scratch the frame, or loosen.

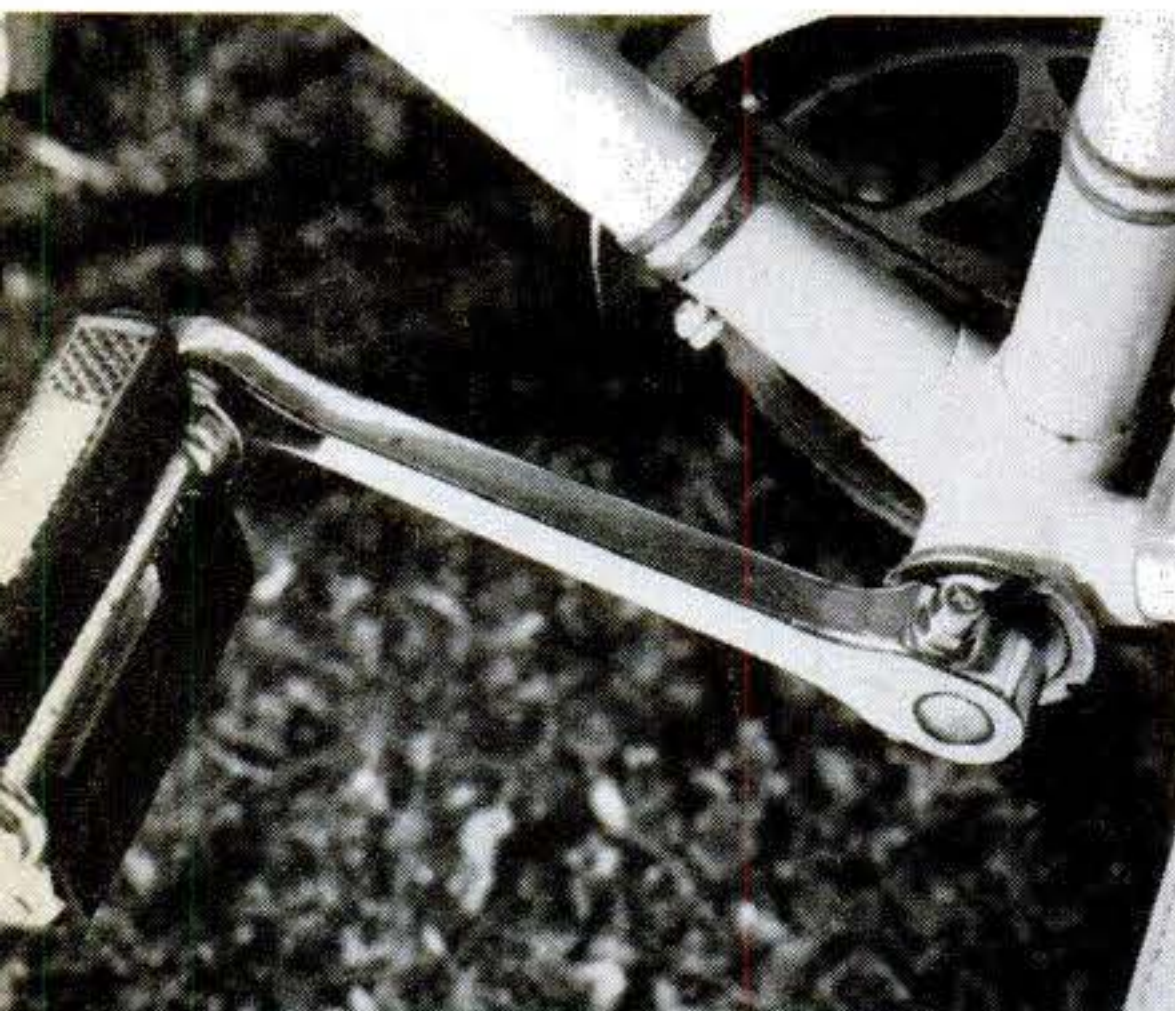

Steel-cottered cranks are found on lower-priced bikes. They are strong but relatively heavy. A rubber-block-type pedal is heavier than a rattrap pedal, and it won't accept toe clips.

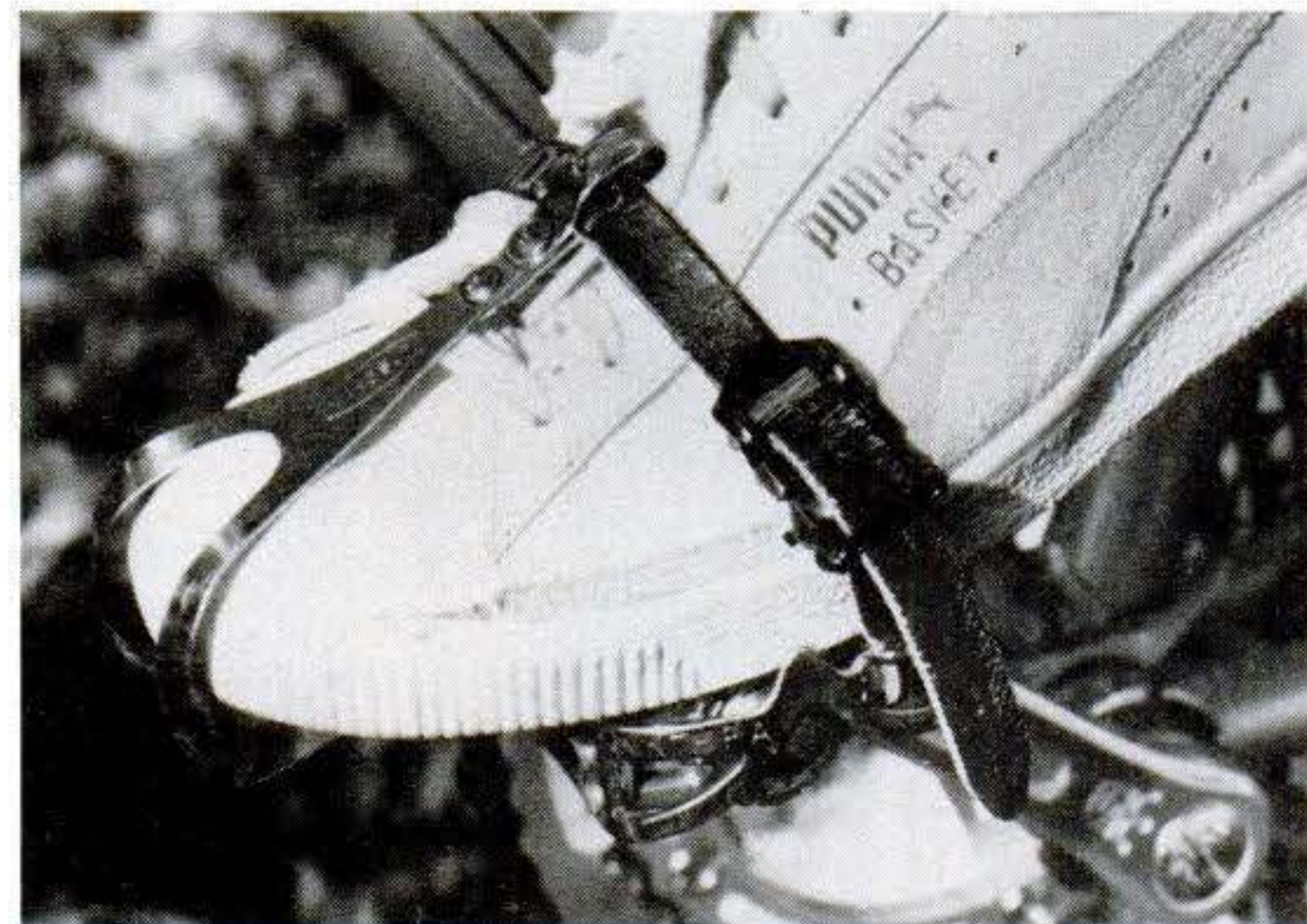

Alloy rattrap pedal is light. I prefer to use toe clips since they not only let you apply power through 360 degrees of the pedaling motion, but also keep your feet on the pedals. (The Consumer Product Safety Commission reports that many bike accidents are caused when riders' feet fly off the pedals.)

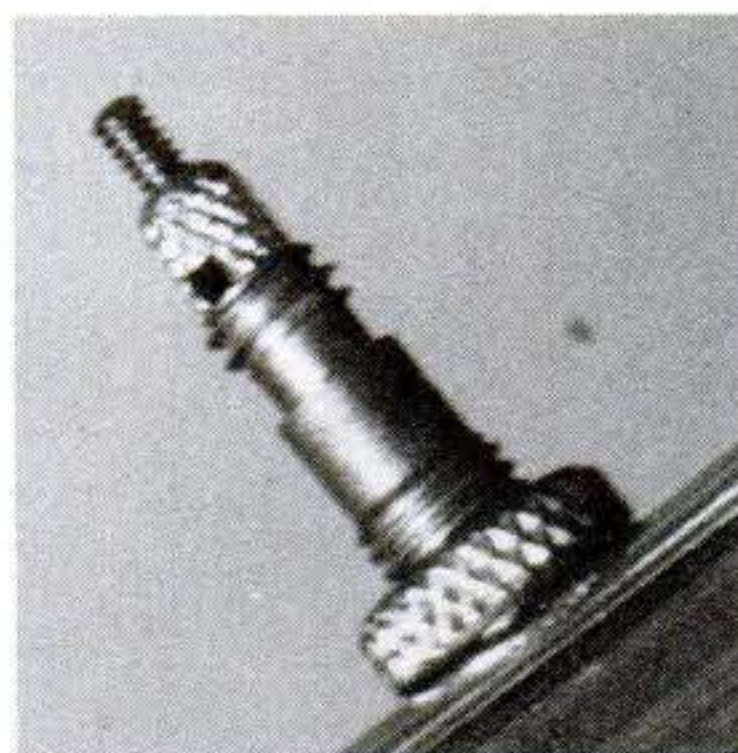

Two types of air valves are available: Presta (left) has locking screw cap (shown closed) to keep air from escaping. It's on tubular tires and newer tubes used with lightweight touring tires. The Schrader valve at right is found on U.S.-made tubes.

The components of a 10-speed bicycle

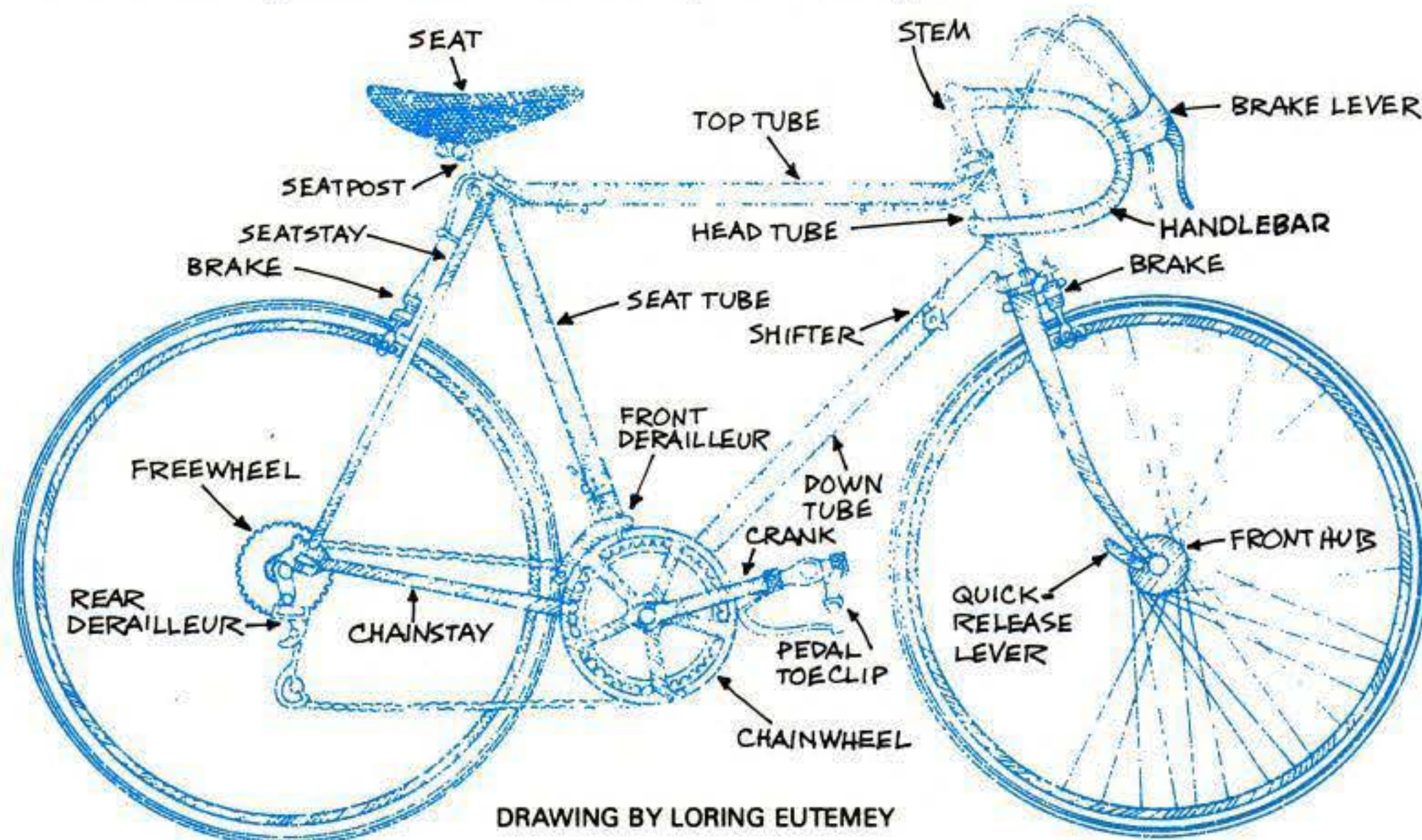

spend? \$100, \$150, \$200, \$300, more? What do you get for the money? The basic components and features to look at when you're shopping for a 10-speed bike are shown in the drawing at left, and the photos and captions on these pages detail some of the more important differences. While bike prices have climbed in recent years, the quality and reliability—particularly of the lower-priced models—have dramatically improved, too. **PS**

FOR FURTHER INFORMATION

Understanding, Maintaining, and Riding the Ten-Speed Bicycle, By Denise M. de la Rosa and Michael J. Kolin (Emmaus, Pa.: Rodale Press, 1979).

The Custom Bicycle, by Michael J. Kolin and Denise M. de la Rosa (Emmaus, Pa.: Rodale Press, 1979).

Mail-order sources of bicycle parts and accessories: **Bike Warehouse**, Box 290, New Middletown OH 44442; **Cycle Goods Corp.**, 2735 Hennepin Ave. So., Minneapolis MN 55408 (catalog \$4); **Lickton's Cycle City**, 310 Lake St., Oak Park IL 60302 (catalog \$1).

Traction-drive transmission

It's infinitely variable, and helps recover braking energy, too

Simple yet rugged design may improve fuel economy 30–50 percent

By E. F. LINDSLEY

DRAWINGS BY RAY PIOCH

TROY, MICH.

As I studied the polished, bearing-steel parts on a table at Vadetec Corp., I began to understand how two conical rollers wobbling crazily inside a transmission could drive a car. But could these 150 transmission parts—contrasted with 1000 in a conventional automatic—really increase the fuel economy of highway vehicles 30–50 percent, as the company claims?

They could, according to Vadetec president Yves Kemper, if the traction-drive transmission he invented is used with an energy-storage system he calls an inertial drive line (IDL). There are three problems limiting fuel economy, Kemper explains: Engines can't operate at their most efficient speeds; energy is wasted while vehicles slow down and brake; and fuel is wasted by idling at a stop. Kemper says his traction-drive transmission, combined with IDL and microprocessor control, solves all three problems.

The new transmission, called a nutating traction drive (NTD) because nutation describes the wobbling motion of its main shaft (see diagram), is a unique development in the 50-odd-year history of traction drives. In this type of transmission, torque is transmitted by parts rolling against each

Continued

Massive drive cylinder for traction-drive transmission is held by Vadetec's Gerard Kemper. Control rings, left, slide within the main case to vary the drive ratio.



other, instead of through gear teeth. Actually, a special oil or fluid I'll describe shortly separates the rolling parts and has a critical function. Such toothless drives are extremely smooth and quiet running.

Machine tools have used traction drive for some time. As early as 1909, the Carter car used a friction drive with two wheels running rim to face—much like some lawn-mower and snow-blower transmissions today. Even in those presynchromesh days, the advantages of friction drive, with its infinitely variable ratios, must have been very attractive.

With no fixed gear stops, you can operate an engine within its most efficient speed and load range regardless of vehicle speed. With the engine on a close tether, you can better tailor emission controls, ignition timing,

valve timing, and fuel introduction.

"The problem has been primarily one of power density," said Kemper, explaining why friction drive hasn't been more widely used. "An industrial drive the size of a 100-hp automotive transmission is rated at only a few horsepower." Experimenters found that increased loads fatigued metal, and broke traction drives apart at the point of rolling contact. The need for higher engine power soon tilted car designers to gear boxes.

Viscous fluid

But one development that has aided continued refinement of heavy-duty stepless transmissions [PS, March '75] is the special oil or traction fluid used between rolling surfaces. The Vadetec NTD uses a fluid called Santotrac, developed by Monsanto Chem-

ical Company. Under the heavy contact pressure between rollers, this fluid becomes extremely viscous, almost solid and glasslike, to help transmit torque from one roller to another.

Better bearing-quality steels are also now available at a time when demands for higher fuel efficiency have revived the idea of a continuously variable transmission (CVT). Vadetec appears to have combined these elements into a design that solves the load-carrying and durability limitations of traction drive.

In Vadetec's development lab, Harvey Pouliot, head of advanced projects, handed me one of the conical rollers. I'd been wondering how the nutating cone could avoid flying apart. "They've been running a long time, many hundreds of hours," Pou-

Continued

Planetary traction drive with a fantastic speed range

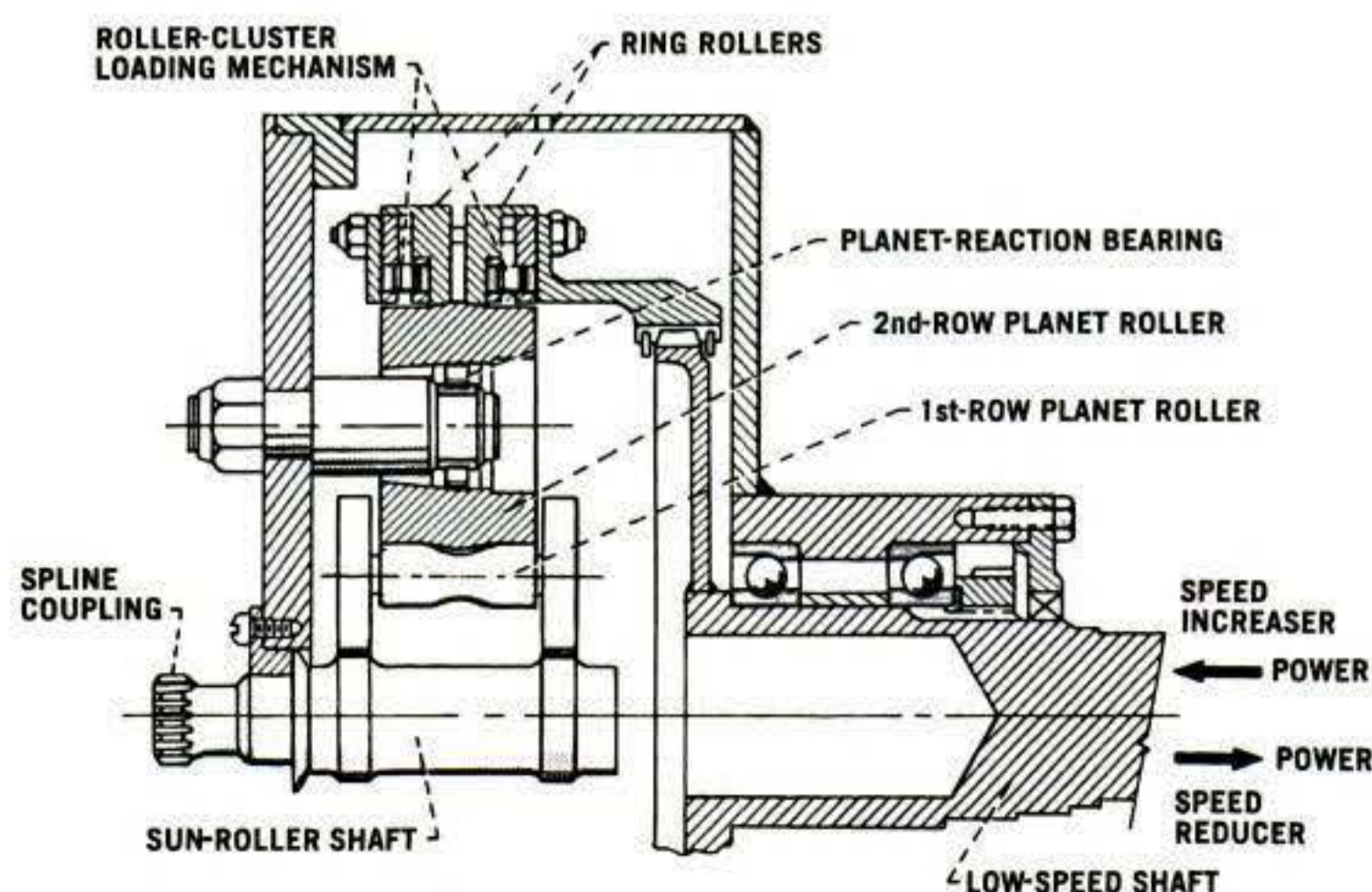
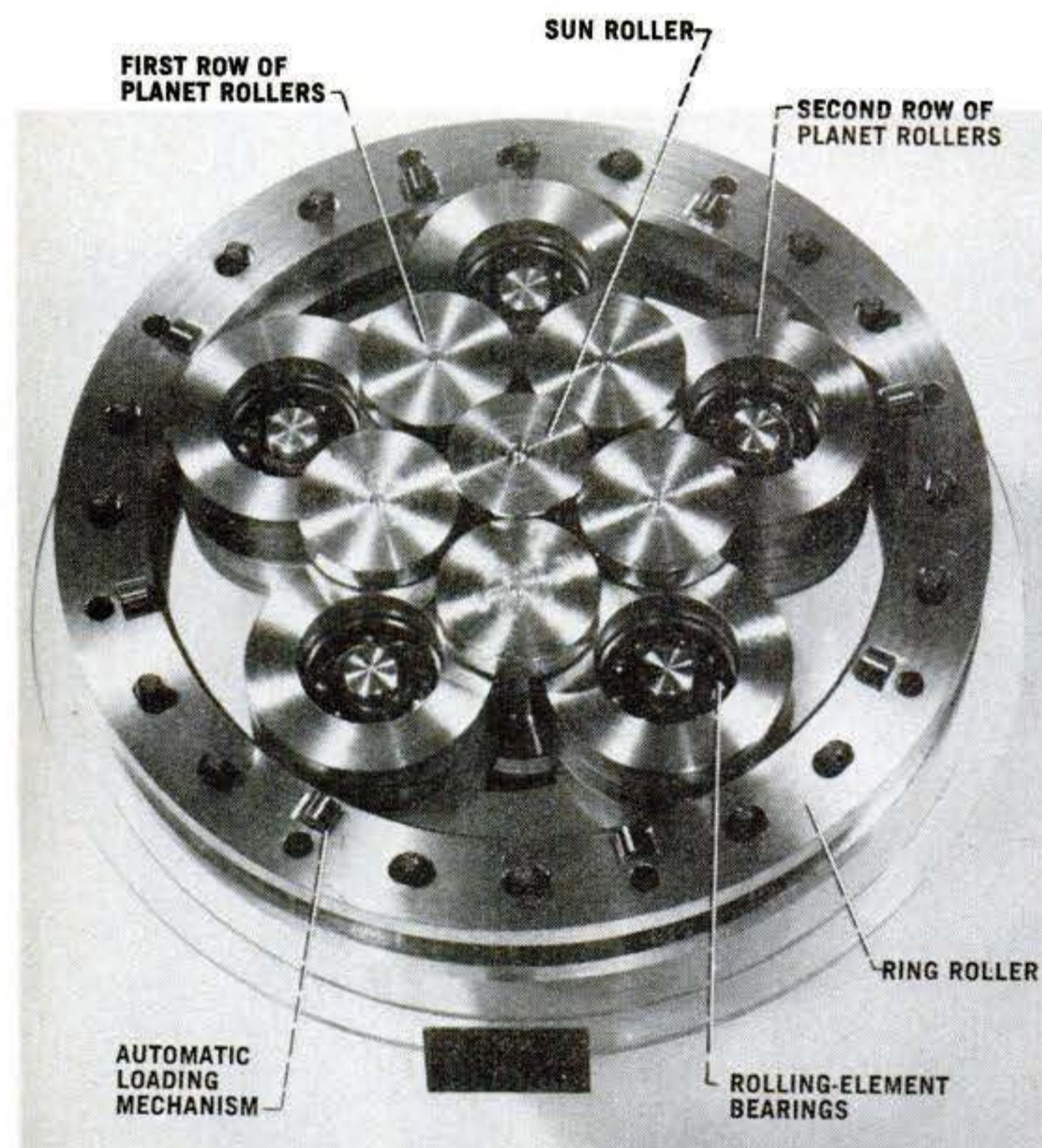

Traction drives offer exciting possibilities for smooth, quiet, and powerful transmissions where gears have always been troublesome. One intriguing new configuration is the multiroller planetary drive invented by Dr. Algirdis L. Nasvytis and further developed at NASA's Lewis Research Center under the direction of Stuart H. Loewenthal.

Unlike the Vadetec variable-ratio drive, the planetary types have a fixed ratio but are capable of dramatic speed-increase or -reduction ratios. Loewenthal's engineering report speaks of operating such a drive at an amazing 480,000 rpm for 15 minutes and at 360,000 rpm for 43 hours. Such speeds are, of course, extreme. These drives' newly achieved ability to transmit high powers and remain lightweight makes them attractive for such modern demands as turbine-engine reduction drives and ultra-high-speed machine tools. The drive shown at left is for a pump, and transmits 30 hp with an input speed of 95,000 rpm. A larger, 500-hp drive has a 48:1 ratio with an input speed of 53,000 rpm.

In another test, the planetary traction drive was substituted for the gear reduction in a Chrysler turbine car and handled the 150-hp, 45,000-rpm input very successfully. At first glance, the Nasvytis drive appears disarmingly simple. It is, in fact, remarkably ingenious—the product of thousands of hours of tests and development. The secret is in stepping the planetary rollers so they actually carry the power through two different diameters. Input may be applied to either the central sun roller (speed reduction) or the outer ring rollers (speed increase).

Consider high-speed input power being applied to the sun-roller shaft. Traction on their larger diameters causes the first-row planet rollers to turn. Their smaller inner diameters drive the second-row planet rollers and these carry the rotation to the ring rollers. Note that neither the sun roller nor the first-planet rollers require bearings since they are centered by their contacts with each other and the second-row rollers. This not only lightens and simplifies the transmission, but also permits more lenient dimensional tolerances; greater, in fact, than the rollers in ordinary roller bearings.

The ring rollers have slightly tapered contact faces to match the centrally raised peripheries of the second-planet rollers. Eight rollers, seated in wedge-shape pockets in the faces of the ring rollers, cause the ring rollers to move together slightly and load the contact faces in response to the applied torque. The centrally raised areas of the second-planet rollers serve a second purpose of locating the first rollers axially by engaging the depressed centers of these otherwise free-floating members.

As described, the output speed would be lower than the input, but by driving through the ring rollers from the opposite end, you'd get a speed increase. This is only one configuration of several tested, but all work on the same principle.

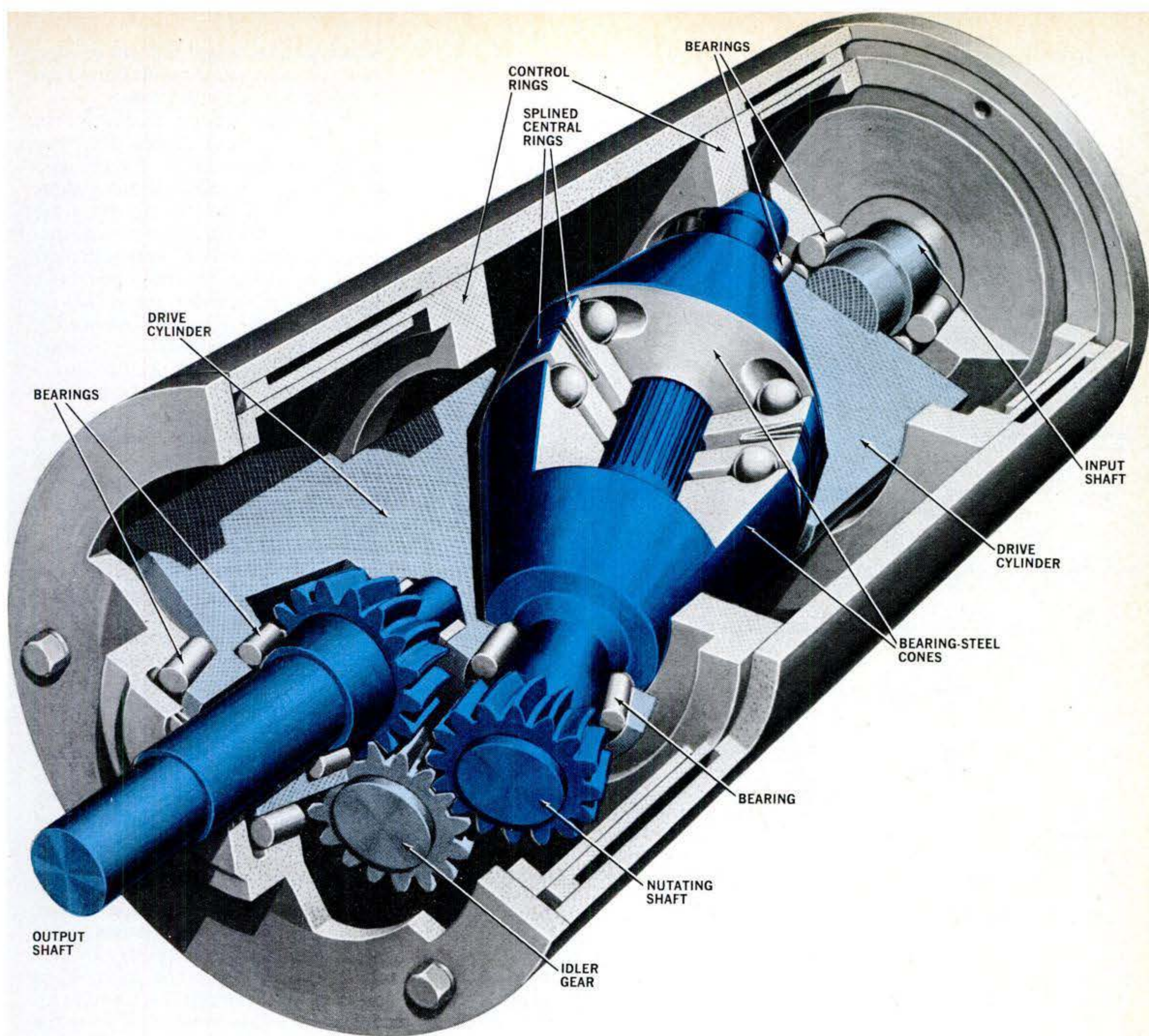

Maximum torque, zero speed

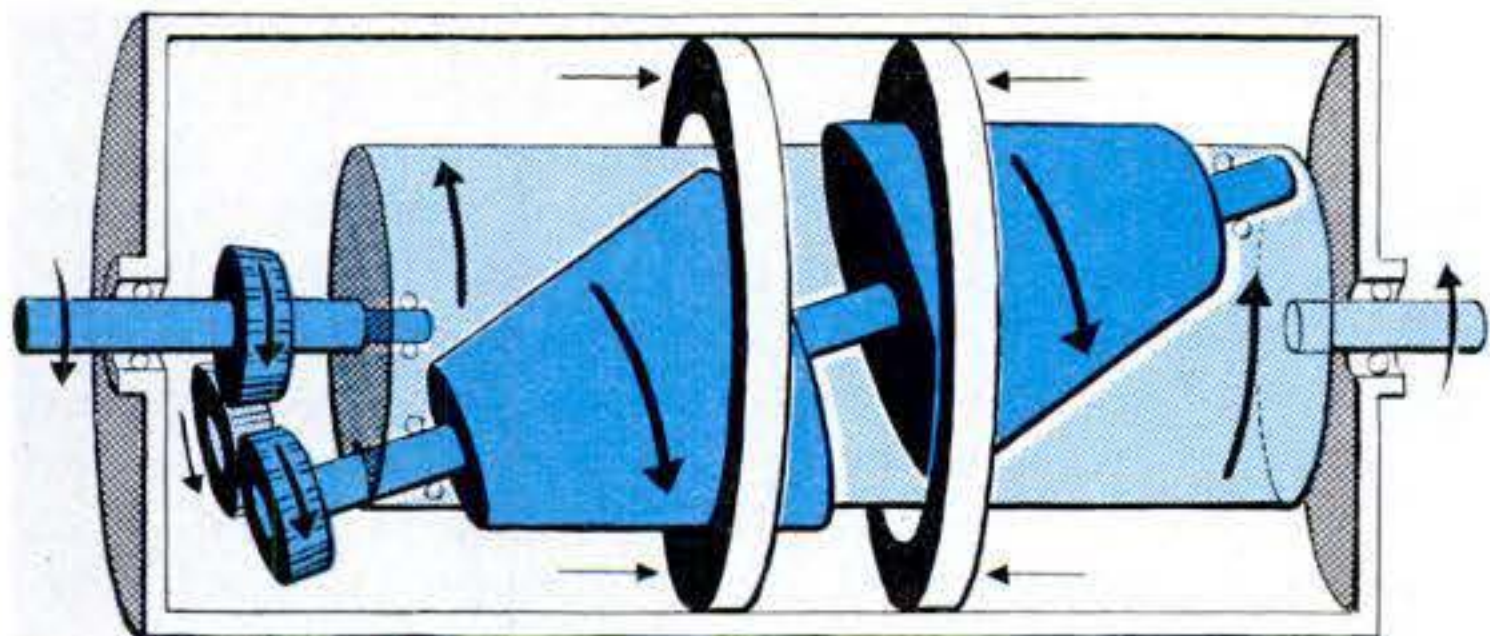

Traction effect between cone surfaces and movable control rings provides driving action between engine input (on the right in each drawing) and output shaft on left. Cones drive nutating shaft, and output gears bring rotation back into line with input and allow performance options for car, tractor, or machinery needs. Cones and rings function as gears, but without teeth. Varying circumferences of the cones, running on the fixed, non-rotating circumferences of the rings, change nutating-shaft speed. Shaft movement resembles a pencil held at its center while describing a circle with each end. When input shaft turns the hollow drive cylinder, shaft and cones are carried around with it. Cutouts in drive cylinder let cones contact control rings. This traction contact rotates cones and shaft through splined central rings in the direction opposite cylinder rotation. Although cones themselves can slide and rotate on the shaft, the two cen-

Minimum torque, maximum speed

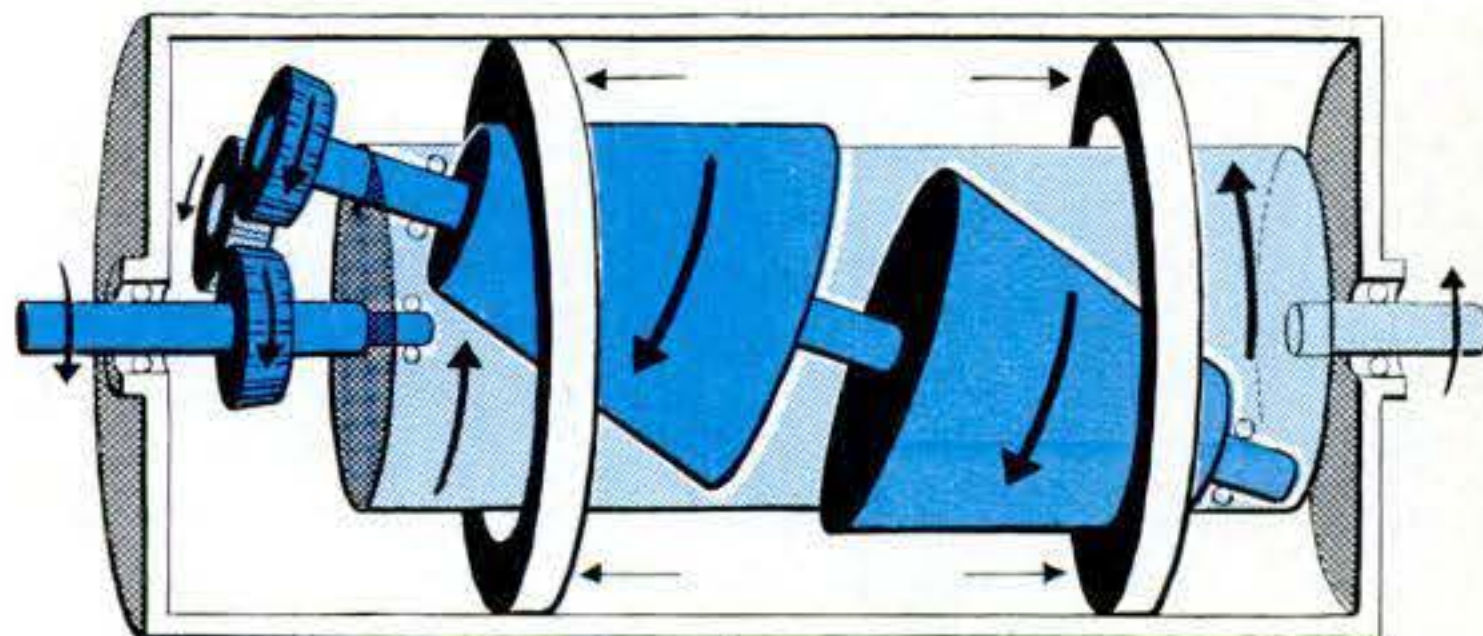

tral rings between are splined to the shaft and, as soon as input torque is applied, steel balls in ramped pockets (see cutaway) act as wedges to lock cones to the nutating shaft. Changing position of control rings brings different diameters into traction contact, varies speed of cone and shaft rotation, and thus the speed/torque ratio between engine and wheels. With the control rings near center (above, left) their inner diameters approximate the cone-base diameters. The cones merely follow around the rings; torque is maximum and speed is zero, as when starting acceleration. Spreading the rings fully apart (above, right) increases cone and shaft speed to maximum, since cones' smallest diameters must roll around the same inner circumferences of the rings. The gear set shown is suitable for passenger cars and permits underdrive, neutral, reverse, and overdrive smoothly and steplessly. Other gearing can be used for heavy-equipment.

Simulating energy storage with a computer

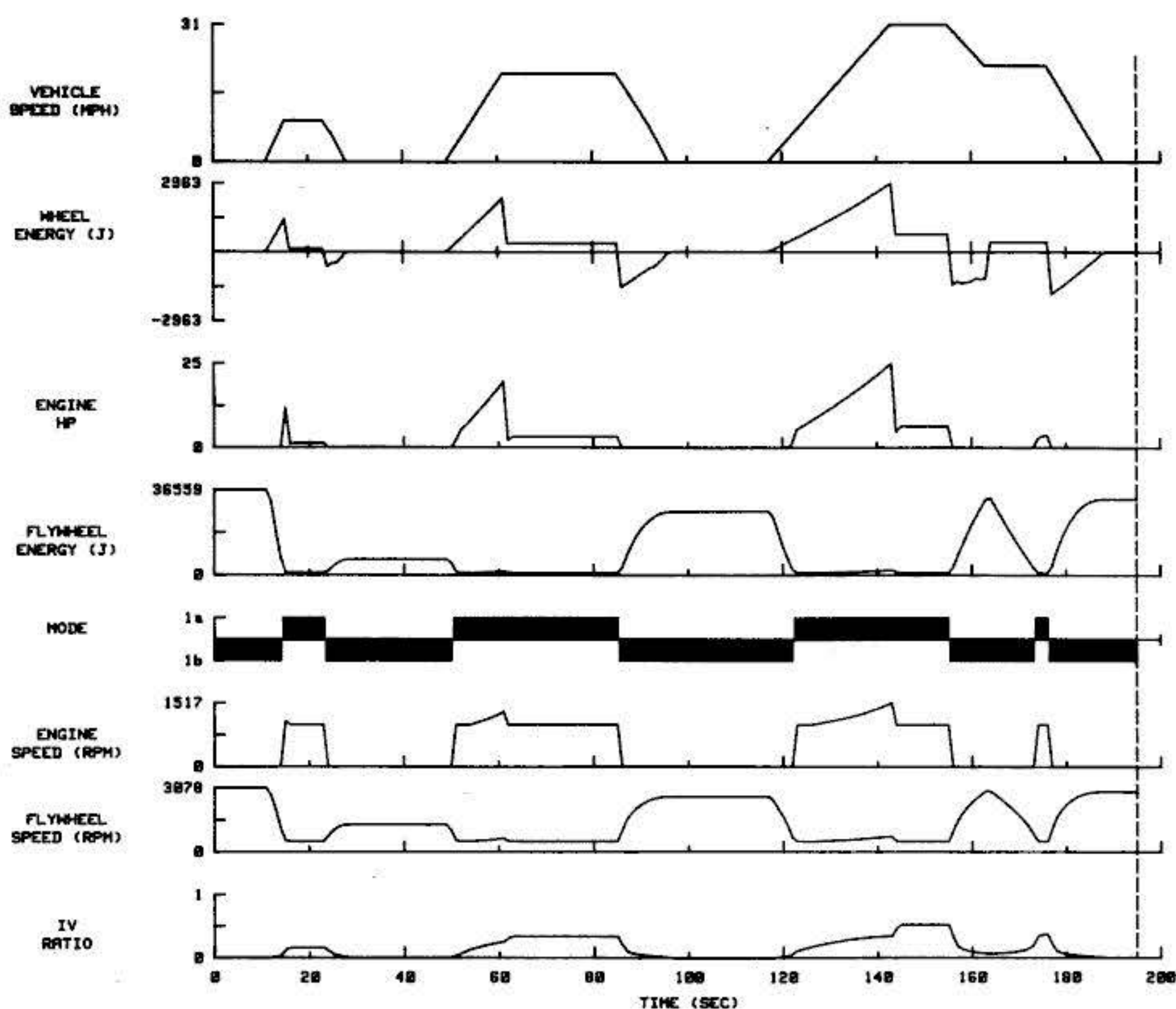

Computer-drawn diagram shows simulated energy balance in IDL-equipped car run through test (European city cycle). Top line shows stops (baseline), acceleration, steady speed, and deceleration. Second line shows energy to wheels above baseline; from wheels to flywheel below baseline. Third line, engine hp, indicates no power during stops (engine off) and

liot said. "The surface just polishes a little and that's it."

"There is essentially no metal-to-metal contact, no damage to the surface," explained inventor Kemper. Nor is there slippage. Kemper's tests show that 94 percent efficiency is possible. Moreover, the Vadetec NTD can drive far more than passenger cars. Since it can handle hundreds of horsepower, it is being considered for bulldozers and big off-highway rigs.

Simple design

Traction oil and high-quality steels, however, have been available to other developers. Why is this nutating design so effective? Study the diagrams and the advantages become apparent. First, there are no complex curves and shapes. Traction contact develops as the convex cones roll around inside the concave control-ring surfaces. The fact that two cones are simultaneously exerting force against the rings helps stabilize the nutating motion.

Tangential force at these two contact points twists the cones slightly on the nutating shaft. This action tends to urge the balls between the cones and rings up the kidney-shape ramps. The wedging action of the balls in the

minimal power output on some accelerations such as first spike, since flywheel energy is being used. This on/off condition is shown in mode line: Above the line, the engine is running; below the line, engine is off. Bottom line shows how infinitely variable transmission changes ratios while driving. To use this diagram, compare plots against car action (top line).

sloping ramps maintains the high contact pressure needed between cones and rings, and also gives instant response to torque changes. The higher the torque, the higher the contact pressure.

Sliding the control rings from the housing ends toward the center, or from the center toward the ends, brings them into contact with different diameters on the cones. This is equivalent to changing gear diameters in a gear drive, and, like shifting gears, it varies the speed and torque ratio.

Despite this relatively simple operation, though, one thing puzzled me about the parts I saw. They seemed very heavy. I knew they'd been machined from solid metal blocks for convenience. But since we're trying to build lighter cars, couldn't the parts be made lighter in mass production? I asked Kemper about the heavy rotating mass.

The weight is used to an advantage, he explained. It's part of his inertial-drive-line concept to save wasted energy. "On the engine, we use it for a storage mass. We recycle the energy," he said. His IDL design calls for another flywheel added to the transmis-

sion's rotating mass to store energy, plus microcomputer regulation to cut deceleration and idling waste.

"With the drive-line change we get between 30 and 50 percent improvement," Kemper said. "Everybody's fighting for one mile, two miles, three miles [mpg gain]. We can get a big jump in city driving." He cites two major gains with his IDL: "One is in recycling the energy [during slowdown]. The other, most important, is that we stop the engine when we don't need it. In city driving, as soon as you start deceleration you don't need power."

Kemper stresses IDL would not require big design changes in existing cars. "The only difference between a conventional power train and that of an IDL vehicle is that the flywheel is on the opposite side of the clutch and that an on-board microprocessor has been added," he said. The flywheel used in the Vadetec design is up to three times as thick as conventional flywheels, but similar in diameter.

The IDL uses a microcomputer to control the engine and transmission in response to driving demands. The engine stops during deceleration and traffic halts, but the flywheel and transmission, on the drive-line side of the clutch instead of the engine side, keep on spinning. As the car slows down, wheel energy is stored in the flywheel.

Running alternators

When you accelerate after a stop, this stored energy contributes power according to its availability. The engine starts and takes over when needed. Accessory drives such as alternators would be operated from the drive line to keep them running during the temporary engine cutoffs.

What about the traditional concerns about safety for high-speed flywheels in vehicles, and the difficulties of an interfacing flywheel, engine, and transmission? Kemper has considered these problems carefully. By not attempting to boost flywheel speed above what it normally would be when attached to the engine, he avoids the complications of high speed. That's also why he limits flywheel mass to no more than two or three times above normal.

Kemper's transmission/IDL concept is intriguing, and the test facilities at the engineering and patent-development firm are very impressive. But I would have liked to have driven a car with the new transmission and IDL system.

A transmission-equipped car will be ready in one to 1½ years, promises the inventor. Kemper is tight-lipped about Vadetec's clients, but it's clear to me that some of them are major car and heavy-equipment builders. ■

Construct your own automatic growing machine

By J. BENTON JONES JR.

For five years now I have grown continuous crops of greenhouse tomatoes without watering, tilling, or fertilizing during the growing season. I have grown a similar easy-care garden out of doors in summer. The system I designed and built is much like a hydroponic garden [PS, Mar. and May '78]: It uses no soil, so it is ideal for areas where soil is poor or garden space unavailable. And it's less subject to weed, insect, and disease problems than a conventional garden.

But the one demanding chore of hydroponic gardening—changing the nutrient solution regularly—is not necessary with my system. Fertilizer is mixed with the pine-bark planting medium before I plant the crops; water from an adjacent reservoir is added—automatically—to a gravel bed below.

All you need to build a system like mine is a watertight container, some pea gravel, and pine bark. A float-valve system is optional. The container needs to be at least 10 inches deep. The width and length can be any dimension—just keep the total size manageable. I use three-by-20-foot units in my greenhouse and three-by-eight-foot units outside. A wood box coated with resin or fiberglass makes an adequate container.

In the bottom of the container, I put gravel to a depth that allows for seven inches of pine bark on top of it; at least one or two inches of gravel is necessary. The pine bark must be no more or less than seven inches deep. If shallower or deeper, it will make the system either too wet or too dry. The whole system works by maintaining a constant water table at the point where the gravel and bark meet.

The pine bark should be horticultural grade with a particle distribution of 70 to 80 percent 1/40-to-3/8-inch size, and 20 to 30 percent less than 1/40 inch. Check with your local garden supplier for a source. Other

materials can be used, but pine bark has proven best for repeated use.

Add to each cubic yard of pine bark seven pounds of dolomitic limestone, 10 pounds of a 10-10-10 (10 parts each of nitrogen, phosphorous, and potash) or equivalent fertilizer, and eight pounds of an equal mixture of gypsum (calcium sulfate) and epsom salts (magnesium sulfate). Mix these materials well into the pine bark. Mixing is easier if the bark is damp. Be sure the gravel is level before you add the bark. Keep the planter level to avoid wet and dry pockets.

On the level

Since the water table must not vary, the water level must be checked daily and more added as needed, unless you install an automatic float valve in the water reservoir. A half-inch-diameter overflow opening should be cut in the container just above the level of the gravel to prevent the system from flooding after a rain. There is no need to water from above at any time, since water will move up through the pine



Spring crop of radishes is harvested by author's daughter. Also growing in easy-care garden: cabbage, lettuce, beans.

bark by capillary action. The surface of the bark will remain dry, but the bark immediately below will be moist. The dry surface seems to reduce the incidence of insects and diseases. Weeds can easily be pulled.

I had superior results with radishes, onions, and beets, but carrots did poorly. Cabbage, cauliflower, and broccoli were excellent, and I did not have to spray to control insects. Lettuce, celery, parsley, snapbeans, southern peas, and lima beans also thrived.

Planting is just as in a conventional soil garden. When a crop is harvested, just pull the remains, run a soil test on the pine bark, add nutrients as needed, and plant again.

My next step is to add a solar collector and extend the growing season of my outdoor garden by heating the water in the base and circulating it through tubes in the bark. With a cover, I may be able to grow almost year-round in my north-Georgia location. For a detailed manual, send \$3.50 to Benton Laboratories, Inc., Box 5455, Athens, Ga. 30604. P 5

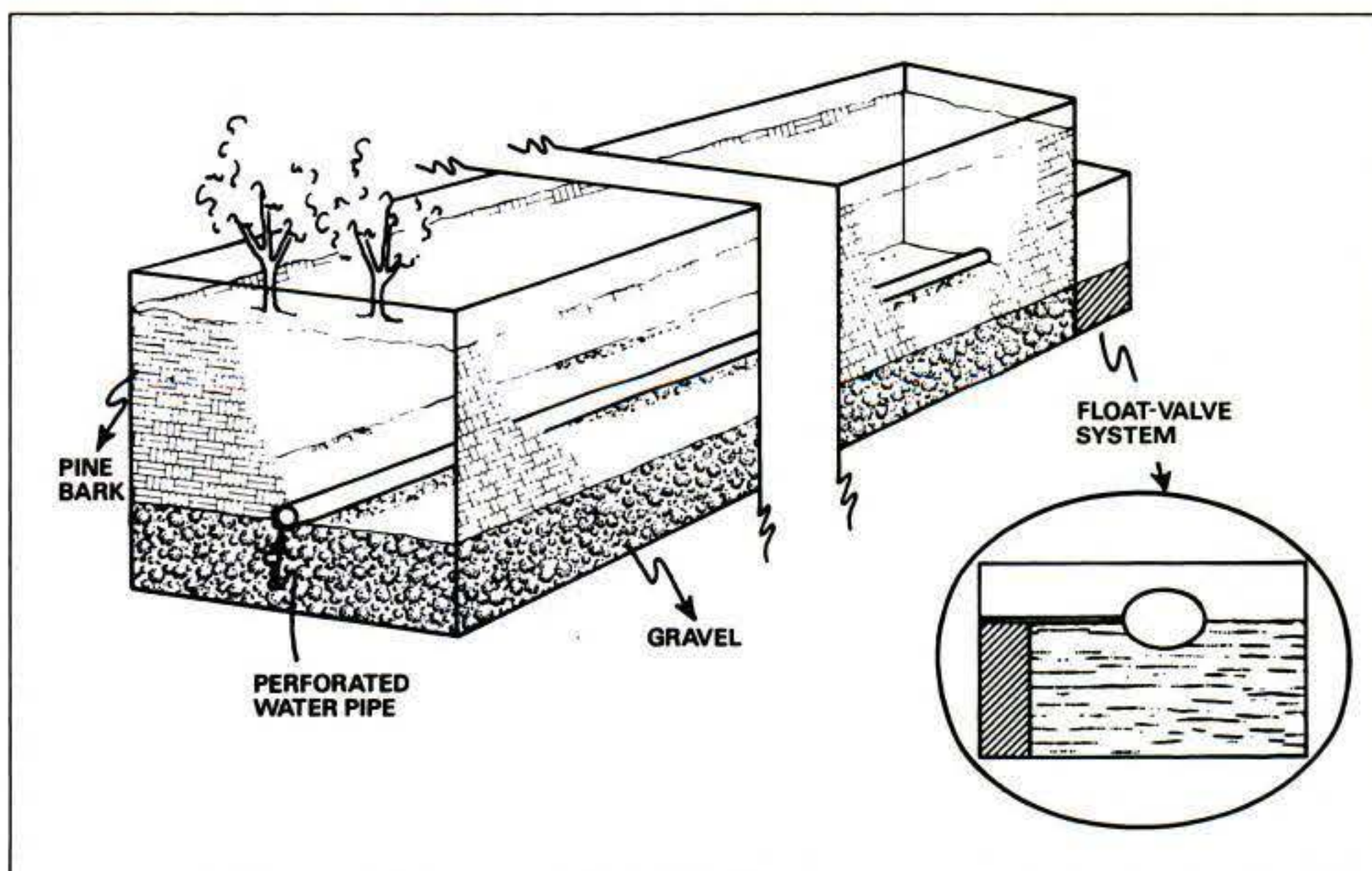

Planting bed can be about any size; pine bark must be seven inches deep. Water pipe has 1/4-inch perforations every six

inches; it distributes water the length of bed. The far end extends into water reservoir. A float valve automates watering.



New yard trimmers

- more gas power
- tougher string cutters
- versatile new blades

By A. J. HAND

The string trimmer is the biggest breakthrough in yard tools since the power mower. A trimmer transforms the job of grooming your property from hours of tedious stooping and snipping into a few minutes of almost magical fun.

In spite of this, consumers have been less than totally satisfied. Too many have been disappointed by bottom-of-the-line trimmers, designed for very light work. Their little electric motors just don't have the power for tough trimming problems, or the working speed to cover large lawns. The result has been an ever-increasing demand for more power.

Manufacturers have noted this demand; this year you'll see many more trimmers with the power it takes to knock down heavy weeds.

This power comes from a gasoline engine. Sure, there are electrics with impressive power. But Americans have never been happy dragging around 100-foot extension cords—witness the limited success of electric mowers.

Electrics still outsell gas trimmers, but every year the gap narrows as more and more consumers become willing to pay the \$100 and more it takes to buy a gas-engine trimmer.

Besides getting extra power and the flexibility of cordless operation, gas trimmers have optional heads and accessories that the electrics don't provide. Examples: Special plastic and rubber blades that outlast and outcut nylon line. Saw blades that can handle brush and saplings. Even a blower attachment that will whisk away clippings and leaves (see photo).

Gasoline trimmer engines take two forms. Many are basically chain-saw

engines, while others are specifically designed for use in trimmers and brush cutters. The majority of these special-duty engines are made in Japan by Kioritz. Which type is best? I've used both kinds and prefer the specialized engines by a slight margin. They run smoothly, with less vibration and noise than the chain-saw types, and take less muscle to start. This makes them slightly less tiring to use.

Direct or indirect drive?

Regardless of engine type, gas trimmers are made in two basic configurations. The simplest places the engine at ground level, mounted at the bottom of the handle assembly. The other places the engine at the top of the handle, with a flexible drive shaft running down through the handle to the cutting head. Each type has advantages. With no drive shaft to break, the direct drive is simpler. But its engine air intake is exposed to dirt kicked up by the cutter. This puts a premium on effective air-cleaner design—and maintenance.

Placing the engine atop the handle keeps it out of the dust and lets the weight of the engine counterbalance the weight of the cutting head. Many drive-shaft units have shoulder belts or harnesses to take the weight of the tool off your arms so they are less tiring to use than direct-drive trimmers. But the drive shaft needs periodic lubrication. And it's a fact that the drive shaft can break—most likely when a brush cutter jams or binds in a sapling or heavy brush, not when you're trimming weeds.

Neither type is inherently superior, but I prefer the drive-shaft types because of their better weight distribution. And this type is always used in

Continued



Axial fan-type blower (above) slips onto Homelite ST-100 cutter (top), producing a 100-mph airstream that whisks away clippings, leaves, and even light snow. The blower is a \$20 option.



Toro 14-cc trimmer (above) has a smooth-running Kioritz engine designed especially for trimmers. The machine cuts a 12-inch swath with dual-line cutting head. One of five new gas-powered trimmers from Toro, it sells for \$180. This is Toro's first year in the gas-trimmer market.

Smallest gas trimmer in Weed Eater's new XR series is the XR-50 (left). It's powered by a Poulan chain-saw engine. The trimmer's adjustable locking collar (between the drive tube and engine) lets you swivel the tube 90 degrees to tip the cutting head up for edge-cutting walks, while still holding trimmer normally. This neat gas-powered trimmer costs \$130.

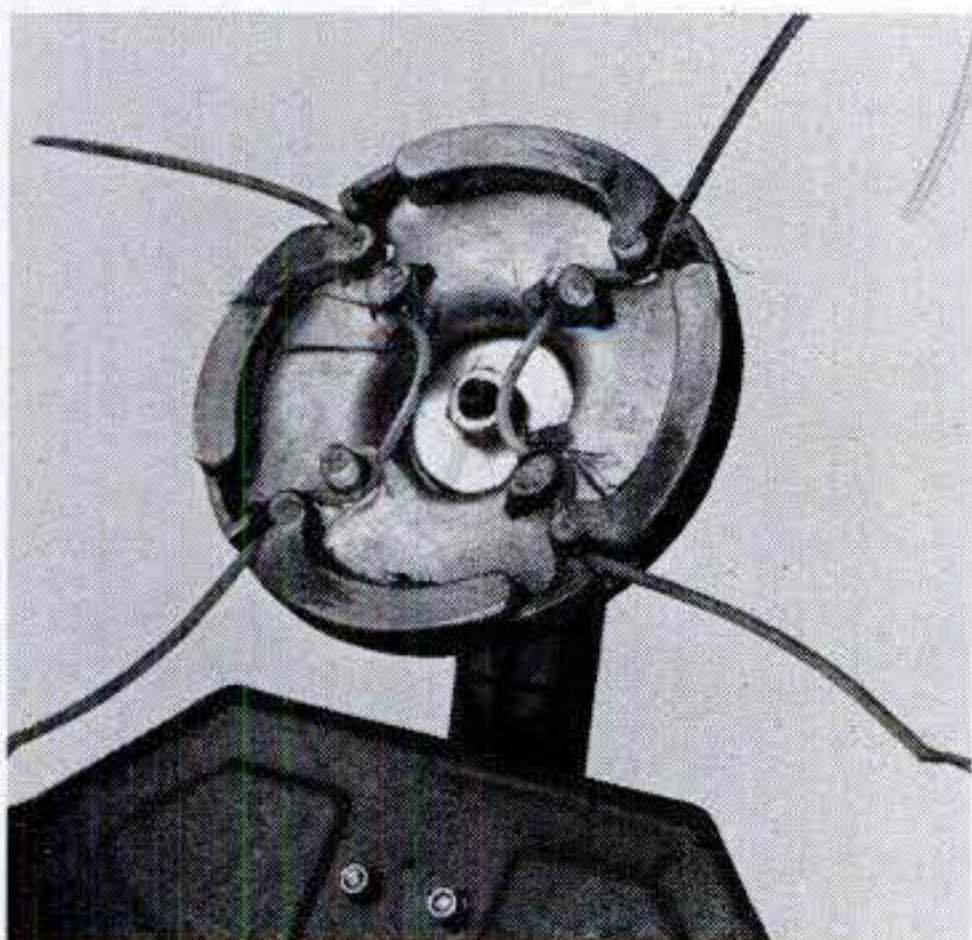

Rugged, 1/8-inch nylon line is about twice as thick as normal cutting line. Too heavy for spools, line must be clipped manually into its Toro head. Lines shown have trimmed heavy weeds for 15 minutes.

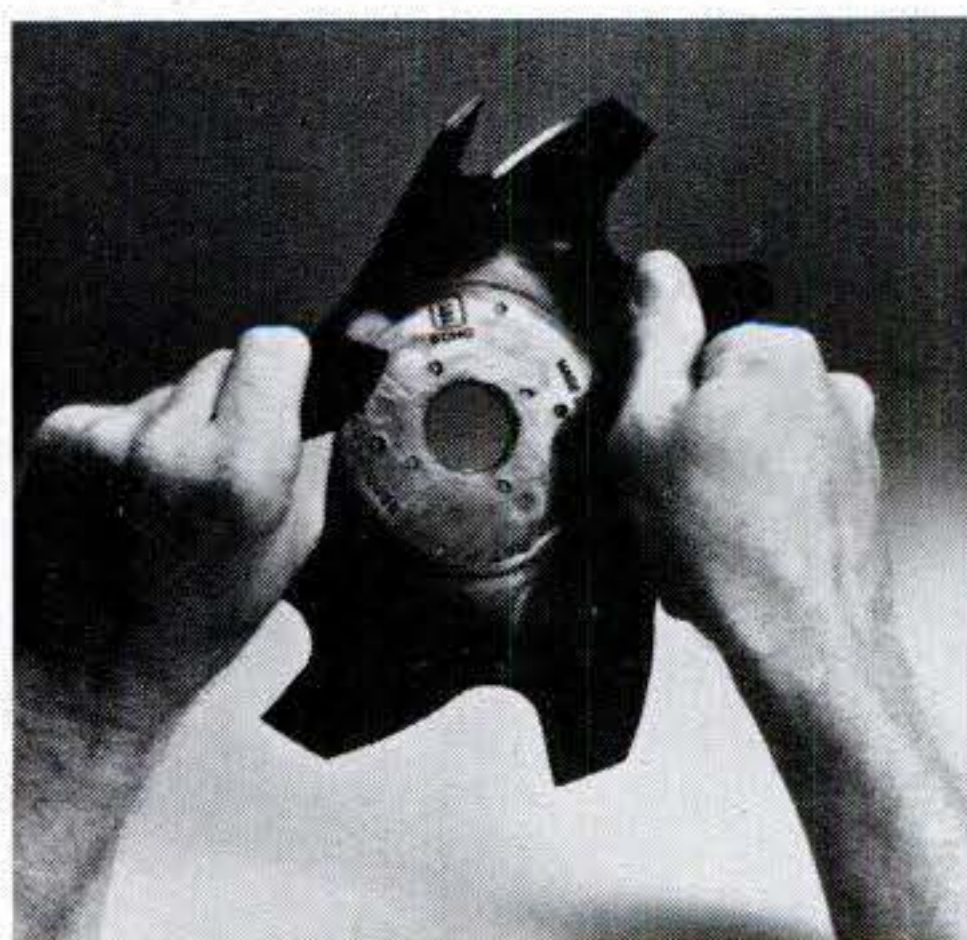

Eight-toothed, flexible plastic blade for the Echo Cutter easily chops heavy weeds. Now available only on the GTL-140 direct-drive model, the blade may be an option on other models next year.

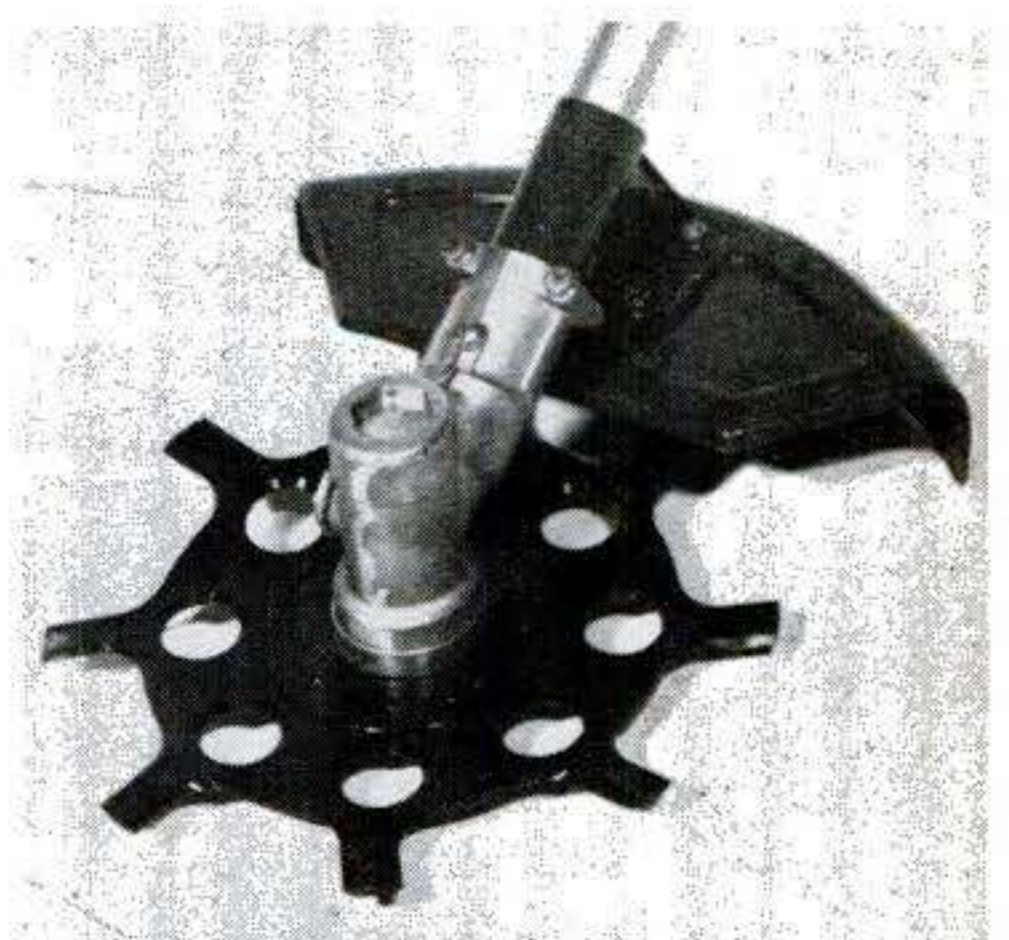

Aggressive design of flexible plastic cutter blade from John Deere enables it to handle heavy weeds and even light brush. Yet the plastic cutter head is safer than rigid steel blades for the same job.



Bolens 12-volt electric trimmer is designed to let you trim as you mow. Cutter

draws power from the tractor's battery. Toro offers a similar trimmer this year.

Toro 30-cc trimmer with brush-cutter blade (inset) can slice down saplings like this in a few seconds. Special harness supports weight of tool, keeps blade at a safe distance from user.

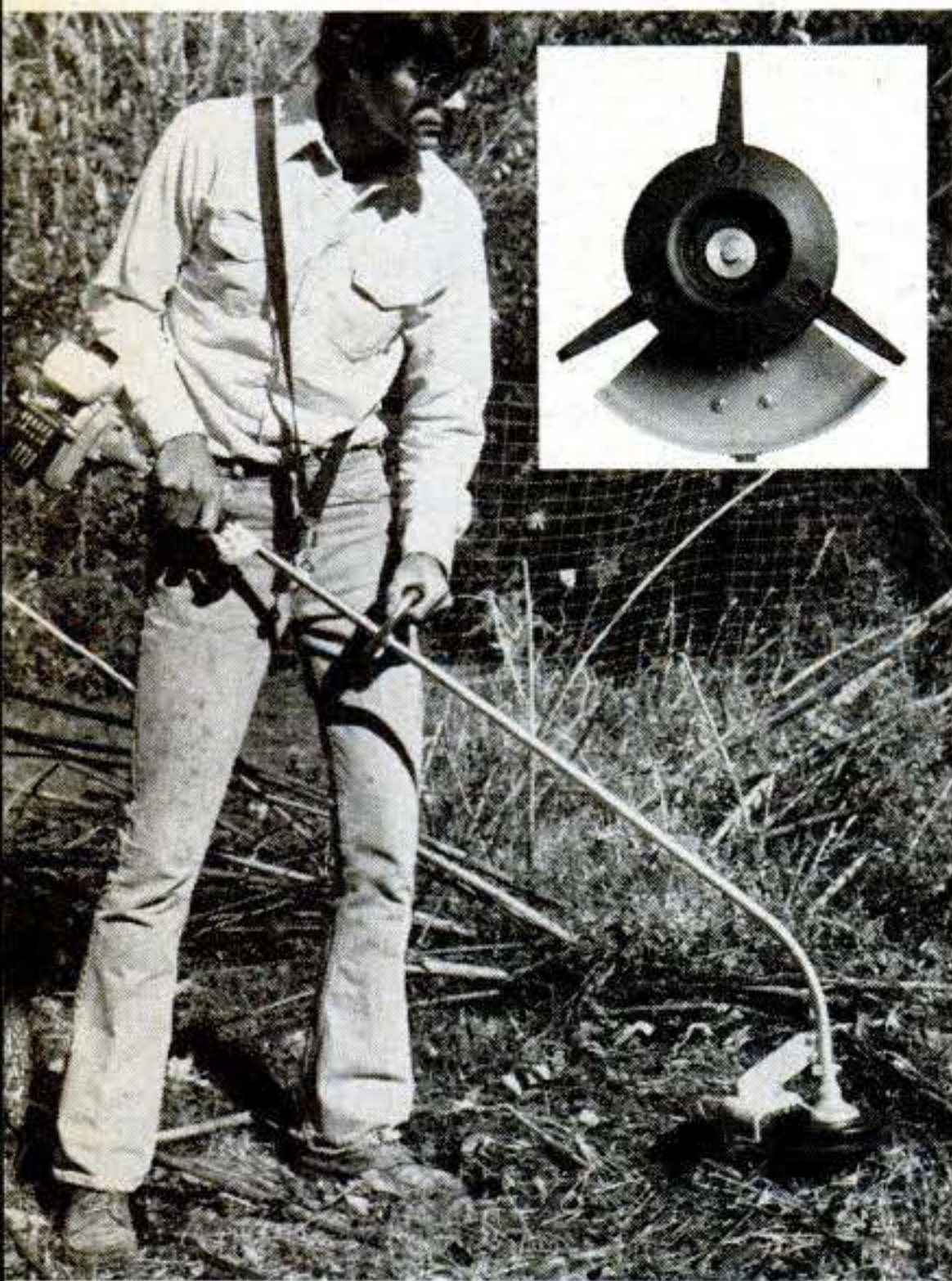

Polycut head on the Stihl FS 60 makes short work of heavy sunflower stalks and other tough growth. Pivoting plastic knives (inset) do the cutting, last for hours, and are easily replaced.

the high-power models since their heavy engines would be too hard to maneuver at the bottom of the handle.

New cutting heads

The original string trimmers did all their cutting with flexible nylon line that trims safely and can cut right up against all sorts of obstructions. The line is best at trimming grass and light weeds. Faced with heavier growth, it won't cut, or does so only slowly.

To solve this problem, Stihl's Polycut head uses pivoting plastic knives instead of nylon line. The Polycut will knock down anything from grass to heavy weeds and even light brush. It does a quick job of scalping bare spots around trees or any place you want kept free of growth. Like string, it will cut up close to obstructions, yet it wears very well.

My only complaint with Polycut is that it is too harsh to use near trees with delicate bark; it will slice right down to bare wood. But for that kind of use you can replace the knives with nylon line.

This year, both Echo and John Deere have also introduced blade-type cutting heads (see photos).

One surprisingly effective head I've tried does the job with traditional nylon line, but wears well and handles heavy weeds with ease. The secret? Extra-heavy line, a full 1/8 inch in diameter, or about twice as thick as most nylon cutting line (see photo).

Extra-heavy cutting

If your property includes some brush or has woods you'd like to keep clear of underbrush, you'll get good service from one of the heavy-duty trimmers that can take brush-cutter blades as well as trimming blades. Brush-cutter blades look like ordinary steel circular-saw blades. When sharp, they can slice through a two-inch-thick sapling in a second or two, right down at ground level so there's no stump to stumble over. These whirling blades are intimidating at first, but they are surprisingly easy to use with a little practice, and are not as dangerous as they seem. They sit at

the end of a long handle assembly which you then harness over your shoulders so it is virtually impossible for the blade to get near your body. The only danger is to fascinated neighbors or children who get too close watching the tool at work.

Finally, Weed Eater has made it easier to do edging along walks and driveways. For this job, you tip the trimmer on edge so the plane of the cutting circle is vertical, and the string slices a neat line in the turf alongside your pavement. Trouble is, tipping most trimmers on edge has always been a bit awkward. Weed Eater's XR series solves that problem with just a simple adjustment (see photo).

What will the new generation of gas trimmers cost you? Probably the cheapest route is to buy a trimmer attachment for your chain saw. Poulan sells one for around \$70 that fits most saws, and Echo offers a similar unit.

A basic gas trimmer runs from about \$110 for the Echo GTL-140 with its Echo Cutter blade to about \$150 for the Homelite ST-100 (without the blower). None of these will take a brush-cutter blade. Most that can are over \$200, but the Echo SRM-140DA is an exception at \$140. The only hitch is that its blade is an eight-incher, while all the more expensive units take 10-inch blades. Examples are the Weed Eater XR-90 at \$200 and Homelite's ST-200—about \$210 when fitted with a geared brush-cutting attachment. From there the prices go up to over \$300, but there's no real need to go that high unless you need a commercial-duty unit.



Mowers for 1980

— rear-baggers take over

By E. F. LINDSLEY

This may be a vintage year for rotary mowers. They have reached a level of quality, performance, and diversity that will be hard to beat in coming years.

Current models offer a wide choice of cutting widths for every possible need. There's one major trend—the move to rear-bag mowers. And though strict new safety standards are pending (see box), safety is not ignored on this year's models.

The new mowers surveyed include all types of walk-behind models—gas and electric, hand-pushed and self-propelled, baggers and nonbaggers—except mulching mowers, which are covered on page 94.

Standard cutting widths of these mowers range from 19 to 22 inches, but there are many options for special needs. Toro, for example, offers a trim 18-in. gas-powered rear-bagger and even a 16-in. battery-powered side-bagger for small or heavily planted lawns. If you've got a big lawn and yearn for a big, long-life, commercial-quality mower, a 40- or 50-in. Gravely is a great choice. Sears also offers two big-cut mowers, a 10-hp, 42-in. and a seven-hp, 26-in.

What to look for

First check the quality of construction. You may have always considered a mower a more-or-less throwaway machine, to be used for a few years and then traded. But inflation may

Continued

Only U.S.-made small mower with separate blade and propulsion controls, the Gravely also features a rotation indicator. Mounted atop 22-in. cutting deck, dial shows when the blade has stopped.





Adjustable handle on Bolens new rear-bagger can be locked in place at the most comfortable position for you. Or it can "float" for quick position changes.

make you want to rethink in terms of buying for longer life. Things to look at sharply: cutting-deck material and structure, wheel materials, axles, bearings, handle strength and rigidity, height-adjustment hardware, and overall finish.

One choice for extra durability is Lawn Boy's Commercial HD. It features a big fuel tank, heavy-duty handle, greasable ball bearings, steel wheels, gear drive, and other rugged details. These Commercials also accept attachments for bagging and mulching.

To mulch or...?

Many homeowners are puzzled by the relative merits of open discharge, mulching, and bagging. One opinion (from the John Deere Co.) states: "If you live in a southern area and your lawn is less susceptible to thatch build-up, then bag the clippings only in spring and autumn." For these regions of the country, a mower that offers both bagging and open discharge may be most desirable, but the discharge may still be side or rear.

In 1980, there will be a surge in sales of rear-bagging walk-behind mowers. Side-baggers are still available, often as add-ons to side-discharge mowers. But the imbalance

caused by the grass-heavy bag on one side (and the problems the bag causes near trees and buildings) has literally tilted users toward mowers that feature rear-bagging.

Yard-Man, for instance, has a new line of rear-discharge mowers with an electric start and a mulching option. At times when the grass is thin, the open rear discharge works well, letting you trim close on either side, and avoid the thrown-object hazard. When you want to bag, you simply open the rear-deck door and attach the bag.

This line has a particularly good safety feature, the husky wheel-adjustment handle on the left rear corner. It enables you to adjust the height on all four wheels at once without getting too close to the mower deck.

Bolens also offers a new rear-bagger series including a 3.5-hp hand-pushed model and two four-hp self-propelled models, one with electric start. These mowers are good examples of what to look for when you're after durability. Turn them on their sides and you'll see solid steel axles running the full width of the deck, from wheel to wheel. Such axles cost more than simply bolting the wheels to the deck or attaching to studs in a cast deck. Over the years the axles usually stand up

Proposed mower-safety standard

Back in 1973, the Outdoor Power Equipment Institute, representing mower and tractor builders, asked the U.S. Consumer Product Safety Commission to develop safety standards for power lawn mowers. The Commission called for viewpoints from industry and consumer groups. The result was a massive compendium detailing a large variety of possible injuries from walk-behind mowers, riding mowers and tractors. For a detailed understanding of the lengthy presentations and arguments that finally resulted in the new mandatory safety standard, it's necessary to wade through 48 pages of closely packed fine type in the Federal Register (Part V, 2/15/79, page 9990). A short summary follows:

Since about 50 percent of all mower injuries—about 77,000 a year—result from blade contact with walk-behind mowers, the Commission chose to tackle these mowers first. The resulting standard has the following main requirements:

(1) The mower must pass a foot-probe test done with a standard-configuration probe on a level surface without lifting the mower. No part of the probe may touch the blade or cause the blade to strike other parts. The probe is used to test both the discharge chute and two areas 60 degrees to each side of center at the rear of the mower.

(2) The mower must have a user-operated blade control that must be held at all times while mowing.

(3) There must be a means of stopping the blade within three seconds after releasing the control. This can't be accomplished by merely stopping the engine—unless it has a power restart on the handle. Otherwise, the blade brake must incorporate a clutch to disengage it from the engine.

The standard also mandates other specific details. These include safety shields, the correct positioning of control, specific capabilities to handle ground depressions and pass obstructions, and a prominently displayed warning label.

These rules won't apply to reel-type mowers or to walk-behinds weighing more than 200 lbs. Nor will they apply to walk-behinds that have over a 30-inch-wide cut or an engine with more than eight hp.

The standard is not scheduled to go into effect until Dec. 31, 1981. But it has already generated a good deal of controversy.

The main dispute centers around this fact: The industry claims that the commission has devised a set of rigid design standards that may cost more and not do the job as well as other possible designs. For example, says the industry, the blade-clutch brake device may cost too much, be relatively unre-

liable, and not contribute significantly to safety. Perhaps, it says, individual manufacturers could devise better ways of achieving the same level of safety, but they won't be able to do so under the standard.

Whatever the merits of the arguments, here are some of the likely results of the new standard:

- No more tin-deck, plastic-wheels-and-an-engine mowers that are mass-marketed cheaply without a dealer-service network.

- More expensive, complicated, and heavier mowers, mostly from brand-name companies.

- Fewer choices of size, model, and type of mower, as makers concentrate on safety details.

- Less ease of use, limited ability to cut close to objects, and some different control characteristics, at least during developmental years.

These changes may not happen for a while. The Outdoor Power Equipment Institute has challenged the new standard, and hearings are planned. Mower builders are not rushing to retool and introduce new models until they know what the new rules are. That's why you won't see big changes or many new models in 1980.

In the meantime, nobody argues that we shouldn't try to reduce those 77,000 mower injuries per year. The squabble is over how.

better to the jouncing from rough ground.

Note, also, the chain drive on the Bolens self-propelled mowers. Such a drive is likely to be more durable than a friction drive or cog tires.

Toro also emphasizes features that can resist the very real beating that mower wheels and drives must endure. On Toro's 21-inch rear-bagger, for example, the drive is through hardened gears and drive shafts and a permanently lubricated housing.

Toro's Select-A-Pace control with three forward speeds also has a unique and automatic adaptation to the uneven spots in your lawn. The drive geometry senses undulation and the drive speed modulates automatically to give a more even cut.

Extra safety features

This year, Honda has expanded its line of mowers that have automatic blade brakes. There are now two hand-pushed and two self-propelled models. On these mowers, any time you release the control handle, the engine drops to idle and the blade, de-clutched from the engine, brakes to a quick stop. On self-propelled models, forward motion also stops.

If the idea of a rather complex brake/clutch mechanism bothers you, look at Gravely's 22-inch, rear-drive, dual-control safety mower. It has a rugged arrangement of separate propulsion and blade controls, with an indicator on the deck top to show when the blade stops turning.

To use, you release the blade clutch grip and the blade stops while the wheels continue to propel the mower forward—useful when crossing a gravel driveway. Or you can grip the blade clutch control and release the propulsion control for freewheeling trimming by hand push. Accidental or intentional release of both controls stops everything but the engine in seconds.

It's clear that many years of experience have gone into design of the 1980 mowers. Another example of learning from real-world use: Snapper now offers choice of a two- or four-stroke engine. Both are three-hp, but in hilly country the two-stroke with its gas/oil mix is less likely to be bothered by lubrication problems than the four-stroke with its oil supply in a crankcase.

Yet another example is the Snapper Zip Kit, a handy rig for the company's baggers that lets you dump cuttings directly into a plastic trash bag without juggling and spilling.

Look for yourself, and you'll find many other instances of practical engineering featured in the latest crop of mowers. P 5



Cutting close on the sides, John Deere's rear-bagger easily maneuvers around most plantings. Deere recommends bagging over mulching most of the time.



Electric start on Toro rear-bagger is safe and convenient, which should make users more willing to stop engine for blade checks without fearing restart hitches.



Options on Snapper's 19-in. mowers include two- or four-stroke engine, mulching adapter, and "Snapperizer," a converter to vacuum and shred leaves.

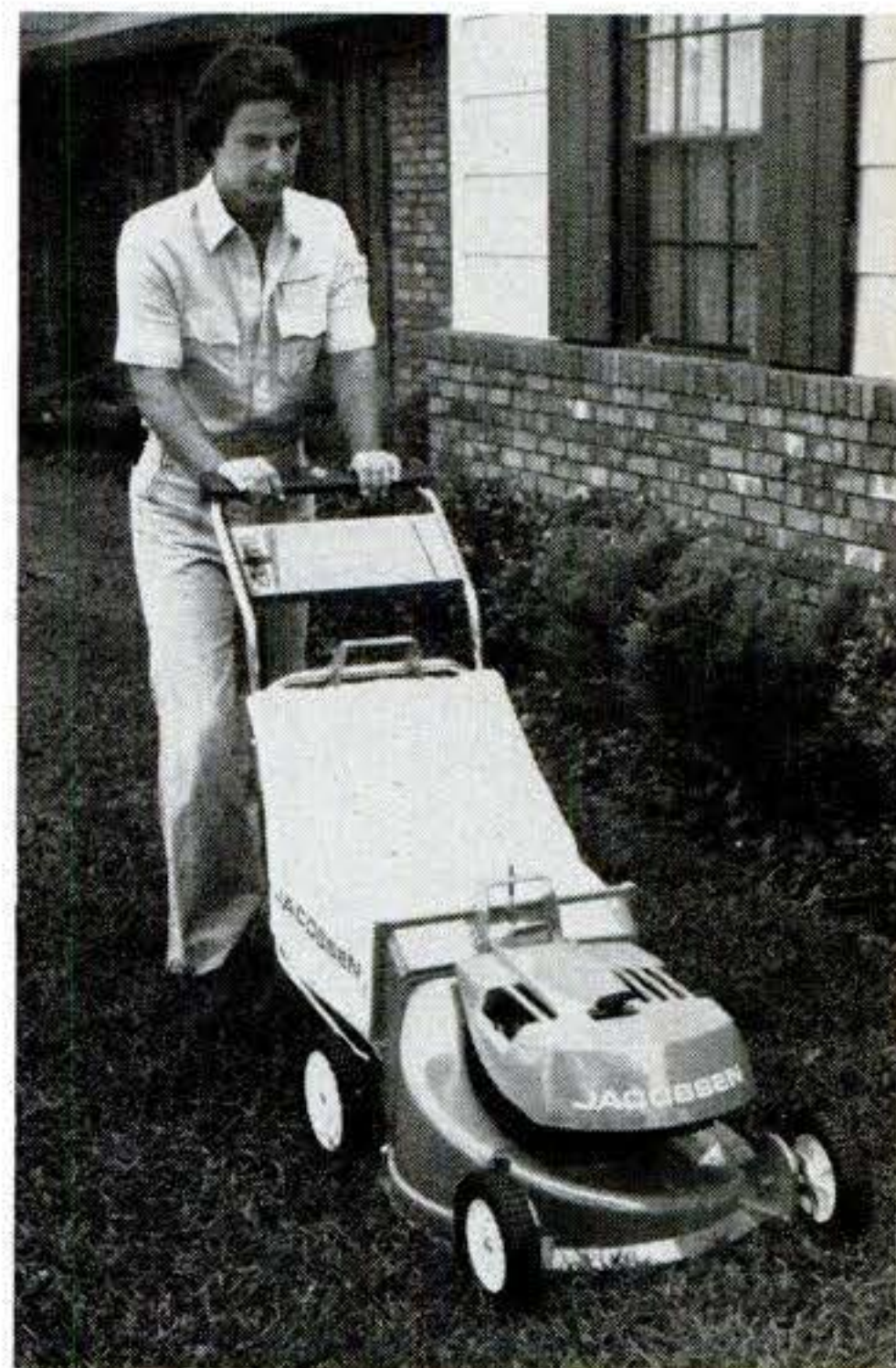

Three-bushel bagger, a Jacobsen mower, is designed for good balance and close side-cutting. There's no side discharge, reducing hazard of thrown objects.

Common-sense guide to safer lawn mowing

1. Your mower is a powerful *cutting* tool. Treat it as such.
2. Your mower is not a toy. Don't let kids operate it.
3. When mowing, your lawn is a work area, not a playground.
4. Stop mowing when passersby walk or drive near you.
5. Precheck the cutting area for stones, toys, tools, and debris.
6. Wear work shoes for protection,

not sandals or soft or open shoes.

7. Stop the engine for bag removal, grass cleaning, height adjustment—and refueling.

8. Refuel in an open area with proper pouring equipment—and no smoking!

9. Put foot *on*, not beside, the mower deck when pulling the starter.

10. Don't use a sick mower. If it won't start in three pulls, it's sick.



OUTDOOR
POWER
EQUIPMENT

Grass clippings vanish under mulching mowers

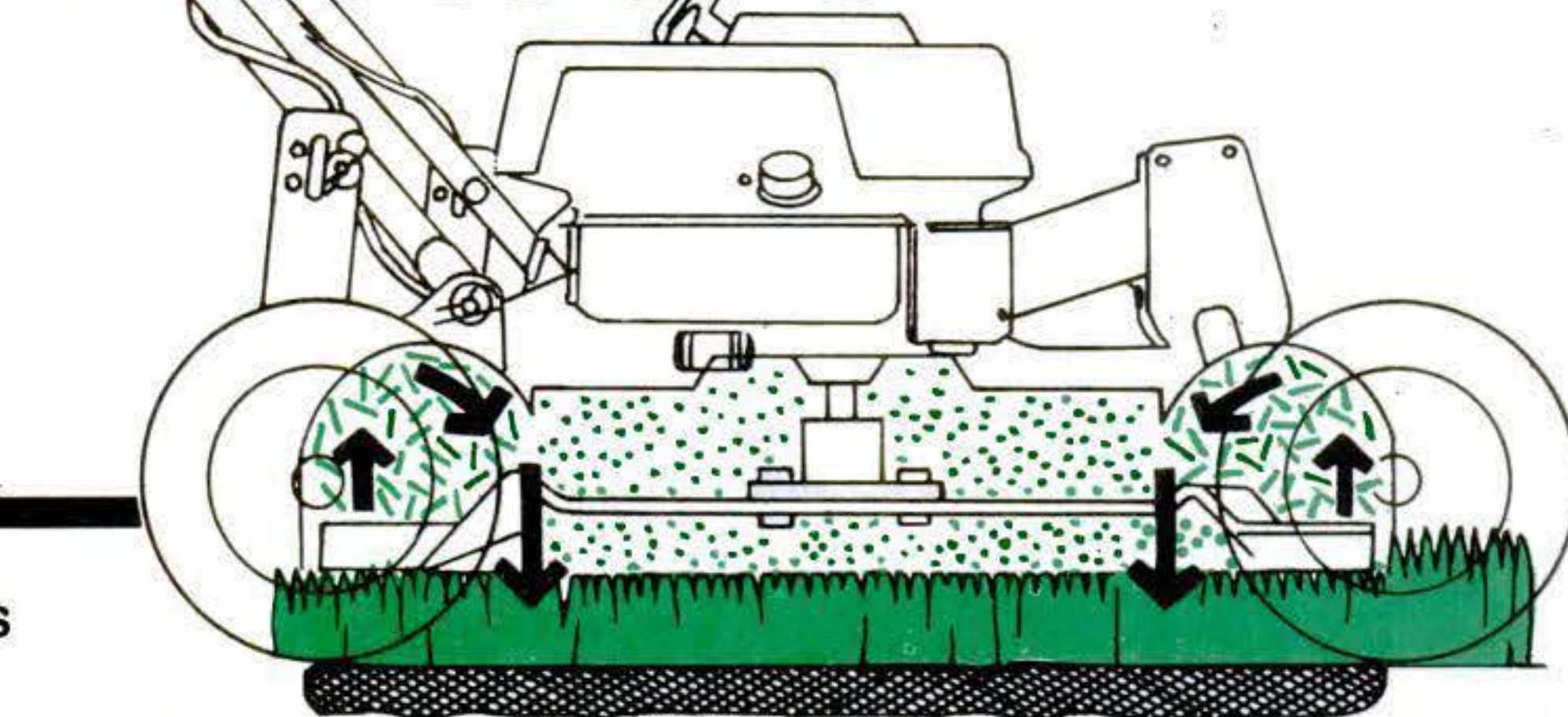

Raking? No need. Mulchers save fertilizer, too

By PAUL BOLON

Mulching mowers have made their point. At least consumers seem to be convinced—almost two decades after Bolens introduced the concept—that mulchers aren't just a gimmick. They're now the fastest-growing segment of the lawn-mower industry. This year there's another surge in the number of new models, and new features (some borrowed from regular rotary mowers) are popping up quickly. For example:

- Toro is introducing the first riding mulchers.
- More self-propelled models and bigger motors are available, as well as electric start and electronic ignition.
- More than half of all mulchers will be convertible to side discharge, side bagging, or rear bagging—virtually a "second generation" of mulchers that try to be all mowers to everyone.

Many potential buyers are still confused, however, about the way these mowers work, and doubt their effectiveness. (Mulchers do closely resemble other mowers.) There is also a lingering controversy within the industry about the suitability of mulchers in all conditions: When should grass be mulched or bagged? Should leaves be mulched?

How mulchers work

Mulchers have a closed cutting chamber and multipitched blades. The blades create an upward suction that stands the grass up for cutting, swirls the clippings above the blades to be recut, and finally blows the escaping debris down into the turf.

Secret of mulchers? Their multipitched blades in a closed chamber. They stand

grass up for cutting, recirculate clippings for chopping, and blow them into lawn.



Attachments for conversion to side- or rear-baggers are offered on some mulchers.

The design of each company's mulcher is slightly different. Jacobsen, for instance, uses twin blades. An extra, flat cutting blade is shorter than and perpendicular to the main blade (see photo). But all of the mulching mowers depend on the aerodynamic effects of a pitched blade to circulate air and grass in the closed, usually torus-shape chamber. The closed chamber also reduces the danger of objects being thrown by the mower blade. Most of the mowers have a preset high engine speed and a governor for relatively constant rpm.

The obvious advantage of mulching mowers is that they save time and la-

bor spent raking or emptying bags of grass. Mulchers halve the time of mowing and then raking; they save about 10 minutes per hour of mowing time compared to bagging mowers.

But mulching your grass can also conserve fertilizer and benefit your lawn in other ways. Smaller grass particles settle near the soil, where moisture and microbiological activity promote rapid decomposition. This reduces the tendency to build up thatch, a mat of nondecaying organic material. A heavy thatch can accumulate on top of soil and impede infiltration of rain water and fertilizer—thus choking the growth of your lawn. A thin



Only riding mulcher at present is made by Toro; it has 32-in. cut in eight and 11 hp.

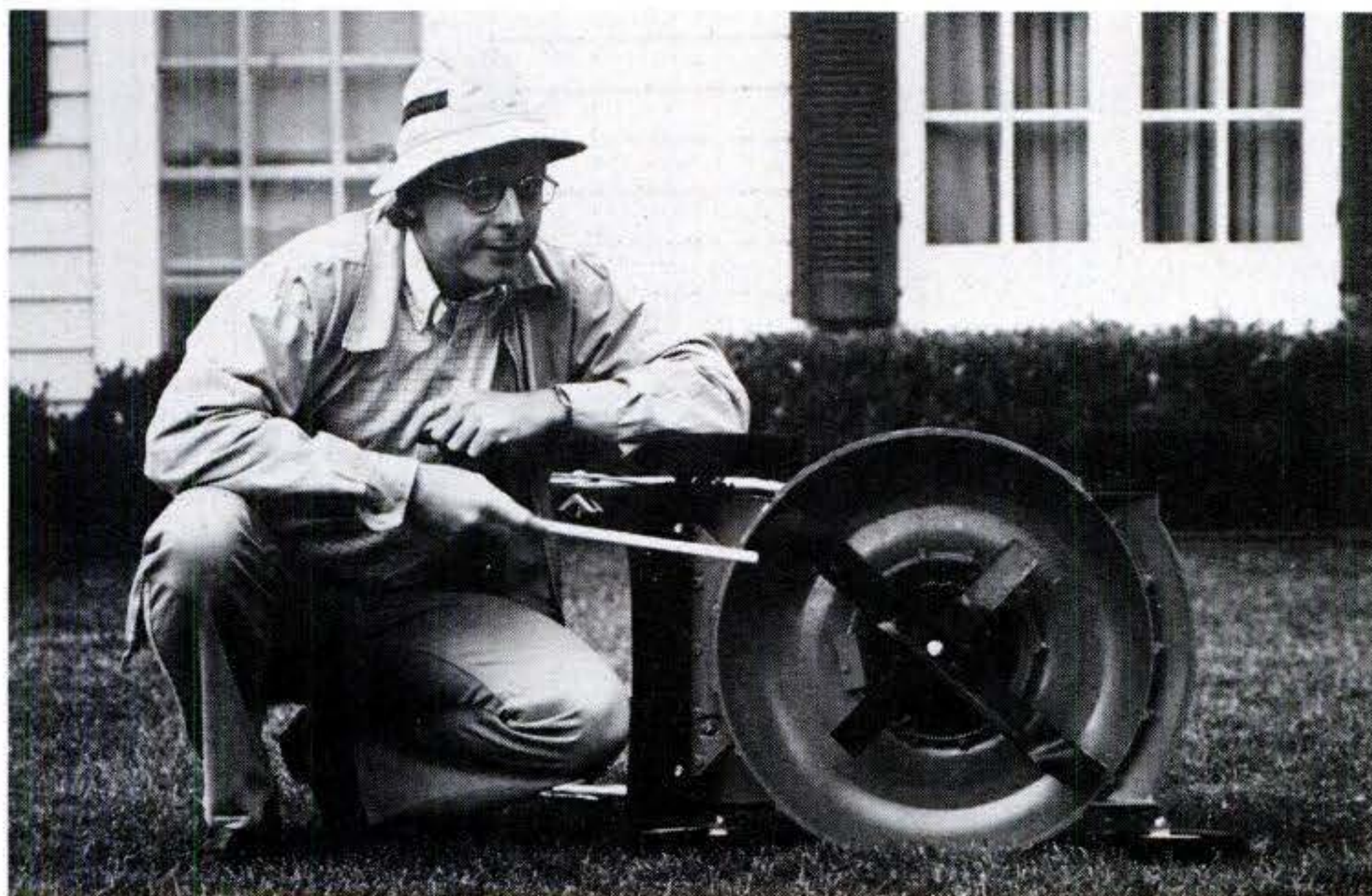

Twin-blade design of the Jacobsen mulcher increases fine-chopping capability.

layer of decaying mulch, however, helps to absorb rain or sprinkler water and also slows evaporation.

The nutrients of these small clippings recycle quickly. Nitrogen can be returned to the soil, be absorbed by roots, and reach the upper parts of plants in as little as two weeks after mowing. This doesn't mean that mulching can replace fertilizer (assuming you have to fertilize your lawn), only that the amount of fertil-

izer can be reduced. Typically, a 25 percent reduction in lawn fertilizer is achieved by mulching the grass—about the equivalent of one fertilizer application. If, on the other hand, you bag cuttings for the first two or three weeks after adding fertilizer, you're just removing a lot of the fertilizer.

Tests conducted at Michigan State University showed that mulchers produce up to 20 percent more clippings of $\frac{1}{8}$ inch or smaller than do reg-

ular rotary mowers. Such small clippings are about half of a mulcher's output. Manufacturers claim that mulchers shred leaves as effectively as they do grass, and Robert Scheri, director of the Lawn Care Institute, confirms that if leaves are chopped very finely, they should not contribute to thatch buildup.

Mulchers do well and save cleanup time under normal summer conditions and with grasses that don't grow too rapidly. But when the grass is high or wet—in spring or autumn, depending on your area of the country—the mowers may have some difficulty. The yard must be completely dry for mulchers to be effective. Since they don't blow out clippings, wet grass results in slow going and clumping. In spring, the grass may have a great deal of moisture of its own and tend to stick even when "dry." Keeping chambers clean and blades sharp is critical to mulcher performance.

Bagging option

High or heavy grass is another problem. In fact, companies recommend setting the wheels for a high cut and mowing again one to three days later at a normal level. Under these conditions a mulcher isn't much of a time saver.

Perhaps that's why mulchers are appearing with an option to convert to bagging. Six of eight Bolens models this year have this option—either side-discharge or rear-bagging attachments that take only a few minutes to assemble. Bolens has three hand-propelled models (18, 20, and 22 in.), and five 22-in. self-propelled models with bagging options. The self-propelled versions have front-wheel drive, which tends to give less traction when hauling a bagful of grass behind. Options include key electric starting, solid-state ignition, and heftier motors. The basic 18-in. model costs \$199; self-propelled models are \$349–\$429 without attachments.

Toro has four 21-inch mulchers. Two models are self-propelled front-wheel driven, and one of these has key electric starting. Three models have handy, safe single-lever height-of-cut adjustment. Prices: \$204–\$389.

Four Jacobsen 20-in. models have lightweight aluminum housing and twin-blade cutters. Two models are rear-wheel driven; one has key starting. Prices range from \$214–\$399.

Simplicity offers three 21-in. mulchers. Two feature bagging options and larger rear wheels; one has rear-wheel drive. Prices: \$229–\$369.

Toro's riding mulcher is a 32-in. model with five-speeds, auto-type headlights, and floating cutting deck. It goes for \$1599, with eight hp. ■



**OUTDOOR
POWER
EQUIPMENT**

From Japan: three lawn and garden **diesel tractors**

By J. RAYMOND TRULL

First in big trucks and heavy equipment, now in cars and pickups—where will you see diesel power next? Perhaps in your lawn and garden.

Last fall I put three Japanese imports—the 14-hp Kubota, 15-hp Satoh, and 15-hp Yanmar—on trial at my homestead. Although tiny compared to up-to-300-hp U.S. farm tractors, they share important features with these domestic giants—features that begin with the engines.

Why diesel? Fuel economy, of course. Diesel engines' high torque—even at low rpm—make them the first choice for super-tough work. And this doesn't mean a shorter life. Many are still youthful when their gas cousins

are on their way to the scrap heap.

Each tractor puts that engine power to work through a two-stage transmission—three forward and one reverse gears coupled to two speed ranges for a 6/2 combination. Differential locks—standard on all models—deliver power to both rear wheels. Need even more traction? Four-wheel drive is available for a healthy price boost.

Like their husky cousins the big farm models, these tractors have brawny components and an extra measure of "rebuildability." Engine-cylinder sleeves and replaceable guides and bushings make rebuilding a good alternative to a new purchase. The Satoh's sleeveless engine accommodates three overborings to a total of 0.040 inch.

Can your standard-size body be happy and efficient on a pint-size tractor? Yes—especially if you're on the small side of "standard." The seats are well padded and contoured, but I found the Yanmar too narrow, too low, and poorly anchored—a surprising fault on a fine machine. In fact, its advertising brochures show a larger seat, so other problems may have been corrected. Hand controls—two transmission levers, hydraulic lift, power-takeoff selector, and hand throttle—are logically and conveniently placed. On the other hand, the extra foot throttles take precious space, complicate climbing aboard, and are often unusable.

As with many diesel cars, glow plugs generate supplemental heat for



Designed for rugged work: Three new diesels are the 14-hp Kubota (above), 15-hp Yanmar (below), 15-hp Satoh (right).

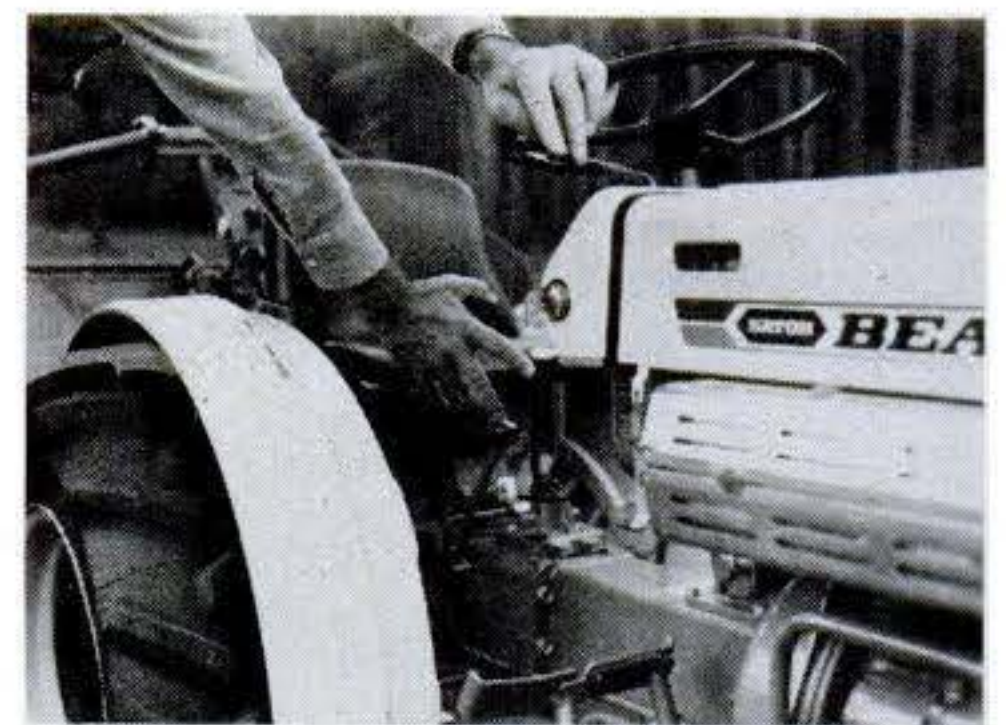

Hand controls are conveniently positioned for easy, "no look" operation on this Satoh Beaver model.

Three-point hitches, an industry standard, fit many implements. Changing tools is quick and simple to do.

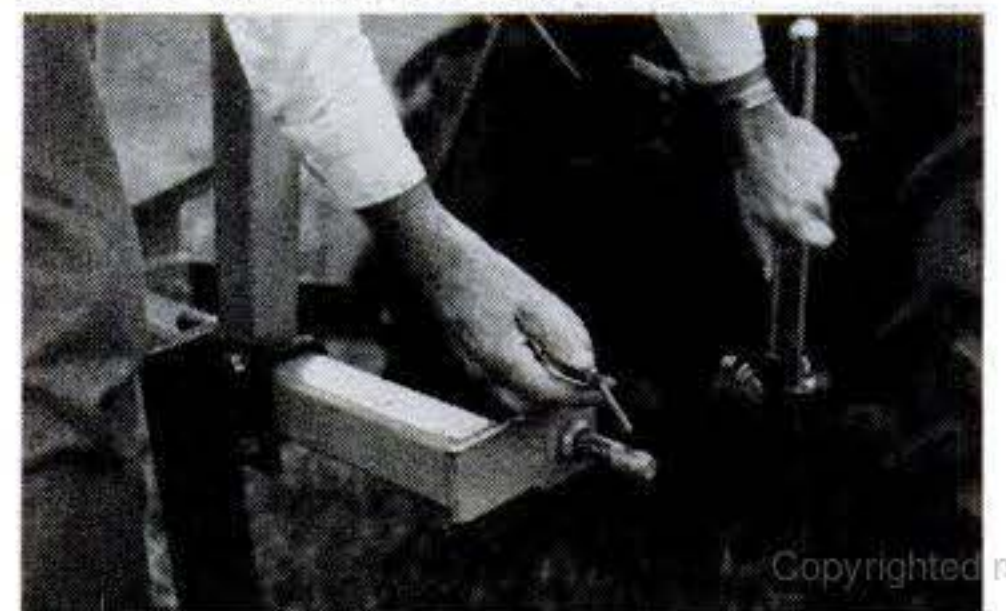
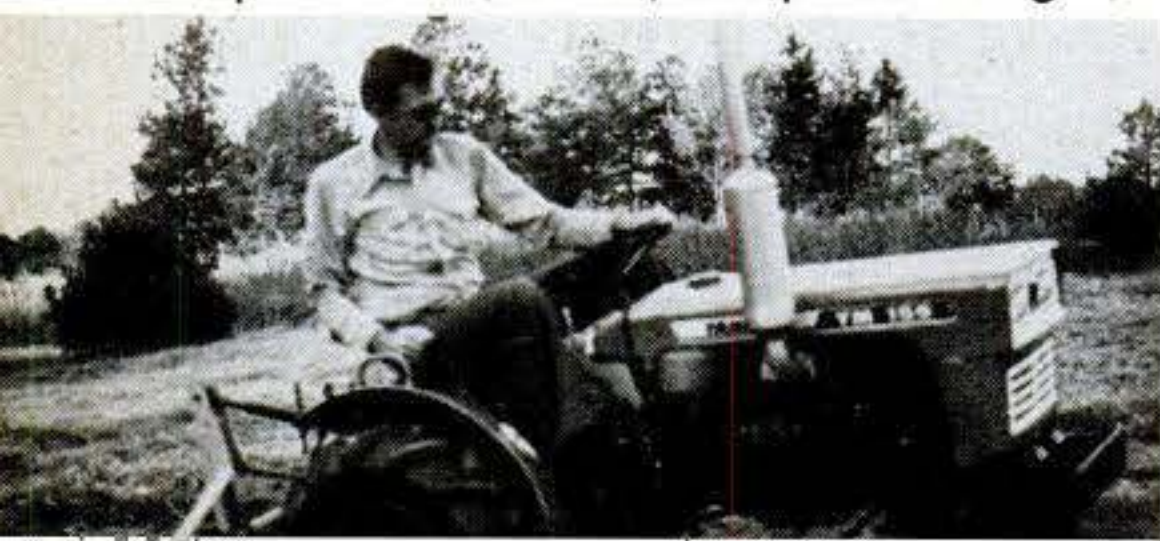

starting the Kubota and Satoh. At normal temperatures the Yanmar uses a compression release. When it's cold, Yanmar's Thermostart system electrically heats fuel before injection. All three tractors started dependably in cold weather.

Plenty of implements

Attachments to mow a lawn and plow a garden are just two of the many home-care, gardening, farming, and construction attachments built by the tractor manufacturers. Three-point hitches—an industry standard—permit use of a wide selection of other imported and domestic implements.

With the rear-mounted mower and most other implements, you attach three hitch arms and power-takeoff shaft and go to work. Mid-mounted mowers are less easily attached but more readily maneuvered around corners. Mowing was a snap. The Kubota zipped along in fourth or fifth gear, cutting a 48-inch swath. In tight places, the diesel's reserve torque permitted me to throttle back for slow-speed maneuvering without downshifting. That reserve torque helped chop through a foot-high stand of super-tough cured Bermuda grass.

Need to cross a driveway or other high spots? Quick hydraulic lifts raise both rear- and mid-mounted mowers. Want to twist and turn like a broken-field runner around obstructions? A short wheelbase and wide-swinging front wheels add up to good agility. Those twists and turns won't develop weight lifter's muscles, either. You can wind all three lock to lock with two fingers.

Forget truck-stop fumes and high-decibel sound. These little diesels are easy to live with. No definite fuel odor accumulated while I stored all three in my garage for a week. Of course, diesel exhaust has a strong odor, but that dissipates quickly.

The three varied widely in their exhaust smoke—one evidence of fuel efficiency. The Yanmar produced virtually none, even when well loaded; the Satoh, a used demonstrator, smoked under moderate loads, but that may have been due to poorly adjusted injectors.

Although different power requirements, throttle settings, and gear settings prevented direct efficiency comparisons, each used about a half gallon of fuel each hour. That's good economy even with fuel at buck-a-gallon levels.

Although all three were quieter than I had expected, the Kubota handily took the low-noise prize—it seemed even less noisy than my rotary tiller's little gas-banger. But these comparisons among tractors were made on in-

herently different exhaust systems. Kubota and Satoh have horizontal, shrouded mufflers, but the Yanmar—loudest to my ears—has a vertical, unshrouded unit.

The good features and long productive life carry one drawback: A significant amount of servicing is required. Kubota and Yanmar purchasers get thoroughly illustrated parts and service manuals, although Kubota's information is occasionally unclear. Yanmar and Satoh supply hand tables of service information and approved U.S. lubricants.

With easy access to dipsticks, filters, and filler tubes, the "most easily serviced" honor must go to Yanmar. Poor access to service components and an absence of dipsticks win Satoh a less-coveted award. But a Kubota engine grille that blocks access to the oil filter deserves special attention.

Satoh and its 43-inch rotary tiller did a quick fall cleanup in my garden. Shredding and incorporating four inches of leaf mulch was too much for one pass, but a second trip left a smooth, seven-inch-deep bed of chopped leaves and soil. Each trip over my 40-by-125-ft. garden took less than 25 minutes—far less than a comparable job with my walk-behind rotary tiller.

Later, the Kubota easily pulled a large turnplow through grass sod. Slicing through the same sod with a smaller "middle buster" was no problem at all for the higher-hp Yanmar, so I used it to quickly rip up an old root-infested terrace. All three tractors have plenty of muscle for lawn and garden chores.

Imports vs. domestics

But which are better—little diesels or domestic lawn and garden tractors? It may depend on the chores you do. Although the Kubota had plenty of power, it didn't match the smooth cut of a neighbor's big-name mower. With a turning radius much shorter than either diesel, that domestic machine left much less uncut grass around shrubs, trees, and buildings. Does your lawn include steep slopes? Domestic lawn/garden tractors' lower, wider profile may be more stable. But if you do a very wide variety of chores, work on bumpy or rough terrain, or are excited by tough, durable equipment, one of these diesels may be for you.

How deep will it plow into your pocket? Prices (as this went to press) for the Kubota and Satoh are \$4050 and \$4075. The Yanmar is highest at \$4300. The tab for domestic lawn and garden tractors begins in the \$1000 neighborhood and soars to \$4000-plus. E

Dual-range tractor



Hop on this new Gilson 18-hp tractor and you'll have two drive ranges at your disposal: A high-speed range cuts grass, tows loads quickly; a low-speed, high-torque range is perfect for everything from tilling to snow plowing.

For the lawn, a 42-inch, three-blade rear discharge is available. The mower is designed to discharge the grass clippings through a chute located between the rear wheels for pickup by a standard pull sweeper. Naturally, without the normal side chute, trimming along fences and shrubs can be done from either side to save time; maneuvering between tight areas is easy. And, with a pull sweeper, cutting and cleanup are done in just one pass.

The tractor uses a twin-cylinder Briggs & Stratton engine for greater performance smoothness. The frame is contoured with a low front and center of gravity for stability and greater visibility. The midsection is narrow and high for more clearance on mid-mounted attachments.

Hydraulic implement lift and electric P.T.O. (power takeoff) clutch are standard on the rig. A dash-mounted switch starts or stops power attachments, and an automatic brake quickly stops the P.T.O. from spinning after it's disengaged.

A 40-inch P.T.O.-driven tiller attachment that mounts directly to the tractor frame for easier control is available. Some 20 other attachments, including plows, snow throwers, dozer blades, and carts, are also available.

Made by Gilson Brothers Co., Box 152, Plymouth, Wis. 53073, the tractor is \$3079.95 with turf tires; \$3109.95 with agricultural tires.—*W. J. Hawkins*



OUTDOOR POWER EQUIPMENT

Quick-setup, car-powered log splitter

I have long felt that the vehicle-powered screw/wedge is the most practical type of log splitter a homeowner can buy. Nothing else can match it for speed and low cost. My only complaint? Setting one up can take 15 minutes. But now a new screw/wedge splitter called the Log Aug has solved that problem, cutting setup time to under a minute.

How? Instead of jacking your car up, placing it on a stand, and bolting the screw to your hub, you simply back your car up a ramp onto a pair of rollers in the Log Aug's base and start

splitting. A heavy chain drive from one of the rollers turns the screw. When you're through, you lock the front roller and drive off.

It's all so fast and easy that I found myself moving the Log Aug around to different parts of my woodpile rather than lugging the wood to the splitter. Transportation to the site is easy, too, since the 100-pound splitter fits in a car trunk.

I gave the Log Aug quite a workout to see how it would hold up. But even after running it for more than an hour neither the pillow blocks supporting the rollers nor the main bearing for the screw showed any signs of heating up. That means they should last a long time—and so should the heavy-duty motorcycle chain drive.

I did have one minor problem. The roller shifts are held in position in the pillow blocks by means of setscrews. These tend to work loose now and then, allowing the rollers to shift and rub on the frame. The solution is to keep after the screws—an Allen wrench comes with the splitter—or to try a drop of a liquid locking compound on the threads.

Log Aug is made by SAK Mfg., 30 Lafayette Square, Vernon, Conn. 06066. It sells for \$389, complete with safety shut-off switch. An optional roller assembly (for a positive-traction vehicle) is \$149.80.—*A. J. Hand*



Back up. . . you're ready to split wood.

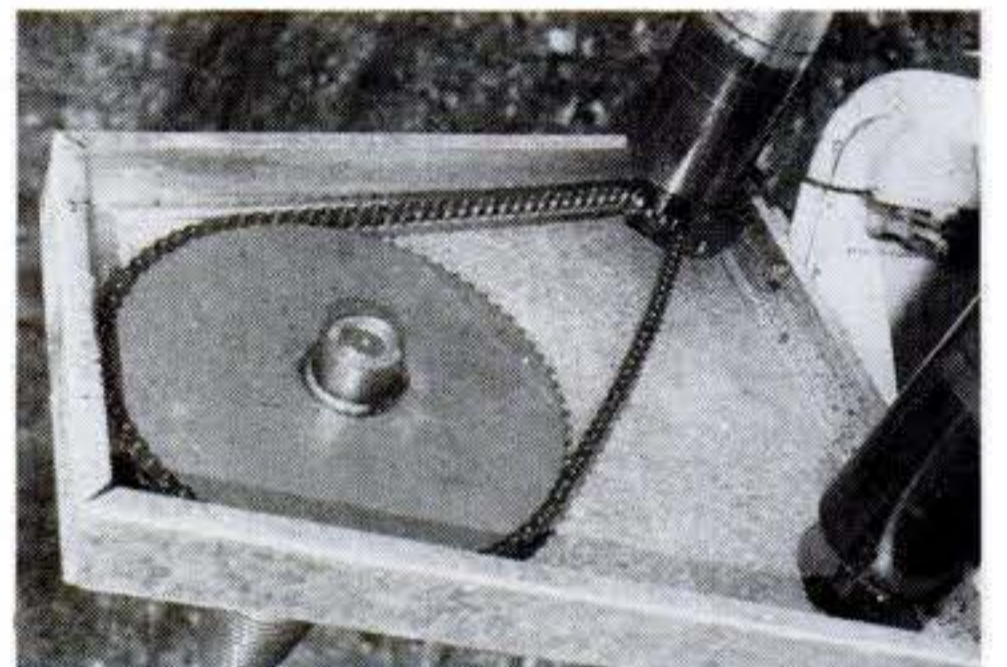

Heavy motorcycle chain transmits power from roller to screw, as this view with the cover removed shows.

Tough new 16-horse tractors

It takes a tough tractor and transmission to put 16 horsepower to work efficiently, especially on ground-engaging jobs, and that's what Simplicity is emphasizing in its new Broadmoor III 6116 twin-cylinder model. The transmission housing is cast iron and drives a limited-slip differential for high traction. On the rear, a single-point Quick Hitch reduces the common adjustment problems when changing implements mounted on a three-point hitch. A single lift lever is used for all implements.

The 6116 has a well-selected gear range from 1.1 to 4.4 mph for both heavy ground engaging and rapid grass cutting. Both the transmission and power takeoff have interlocks to prevent starting while engaged.

The center-mounted mower may be either 42 or 48 in., the snow thrower is 26 in., and the garden plow is the popular 10-in. size.—*E. F. Lindsley*



Two front-tine tillers

The popularity of the front-tine tiller remains high because of its all-season versatility as a weeder and cultivator after initial seed-bed preparation. Two new tillers, both five-hp chain drives, from Ariens and Gilson extend that versatility even further by converting to two-wheel tractors. Used as tractors, they can pull garden-sized



Ariens front-tine tiller has 14-in.-dia. tines and a seven-in. tilling depth.

Rubber mower blade cuts grass, not shoes

If a rubber blade for your rotary walk-behind sounds a bit silly, think again. After cutting some heavy, damp, spring grass with one, I couldn't tell the difference in performance from a conventional steel blade except that it seemed a bit quieter. The object, of course, is to make a safer blade and reduce possible direct injuries to feet and hands and indirect injuries from thrown objects. And there's an added advantage if you accidentally run the

blade into a stone, walk, or other immovable object: It doesn't appear to do the blade or the engine shaft any damage.

The Safe-T-Blade is made of flexible rubber with internal nylon cords and a hub-area steel insert. It's safer than steel, but won't prevent all injuries. I certainly wouldn't put my fingers in it because even the rubber blade could whack them up badly. But I did try putting a conventional street shoe into it quite a few times. It didn't penetrate or slash the toe, but it did dent it and tear out the tongue. Not bad; previous tests with a steel blade and a shoe always resulted in severe slashing. Moreover, an egg-size rock

bounced around and made a lot of noise, but nothing else happened. My conclusion is that if you wear sensible work shoes—not open-toed sandals—the rubber blade is definitely safer than conventional steel.

The Safe-T-Blade comes in a full 22-in. size, and you simply cut off the excess at the proper marks to suit your mower. As with any blade, it will get dull, but it's easily sharpened with a file or bench grinder.

Safe-T-Blades for mowers cost \$9.95, an edger blade \$5.95, and a weed-cutter blade \$7.95. Maker: Safe-T-Blade, Inc., 6040 North 7th St., Suite 101, Phoenix, Ariz. 85014.—*E. F. Lindsley*



Running over this shoe several times with rubber blade did not produce slashing and shredding typical of damage caused by a metal blade. You can see a dent in the toe.



Flexible, but not soft, is the feeling you get from the new safety blade. The rubber mower blade has the same shape and size as steel blades. The changeover is the same as with any blade.

spring-tooth cultivators, furrow openers, and other implements.

The Gilson machine has 14-in. bolo tines adjustable from 12 to 26 in. An optional power reverse is offered. Gilson says that special attention has been paid to placing most the weight over the tines for better performance.

The Ariens tiller adjusts from 12 to 24 in. and has a full-gallon fuel tank to reduce those bothersome refueling stops.—*E. F. L.*



Deep-digging Gilson rotary tiller has most of its weight balanced over the tines.

Portable power for yard work

Homeowners who have been disappointed with the ability of low-wattage generators to carry vital house-power loads during outages will be interested in McCulloch's new five-kW, 10-hp generators. The 5000 watts is just about right to operate your heating system, freezer, refrigerator, well pump, and lights—even though it may be necessary to do so selectively.

The domestic version of these units weighs 144 pounds and has both 120- and 240-volt plug-in connections. For the safest and most convenient feed to household circuits, a transfer-switch connection should be installed by a professional electrician. The generator has a built-in overload circuit breaker.

A slightly different version of this generator is available for remote field use on construction and similar applications. This model has a wraparound cradle, control panel, idle control, and lift hook. Sustained generator loads make heavy demands on engines, and both models have cast-iron, industrial Briggs and Stratton engines. The domestic unit is \$1399.95; the industrial model, \$1499.95.—*E. F. L.*

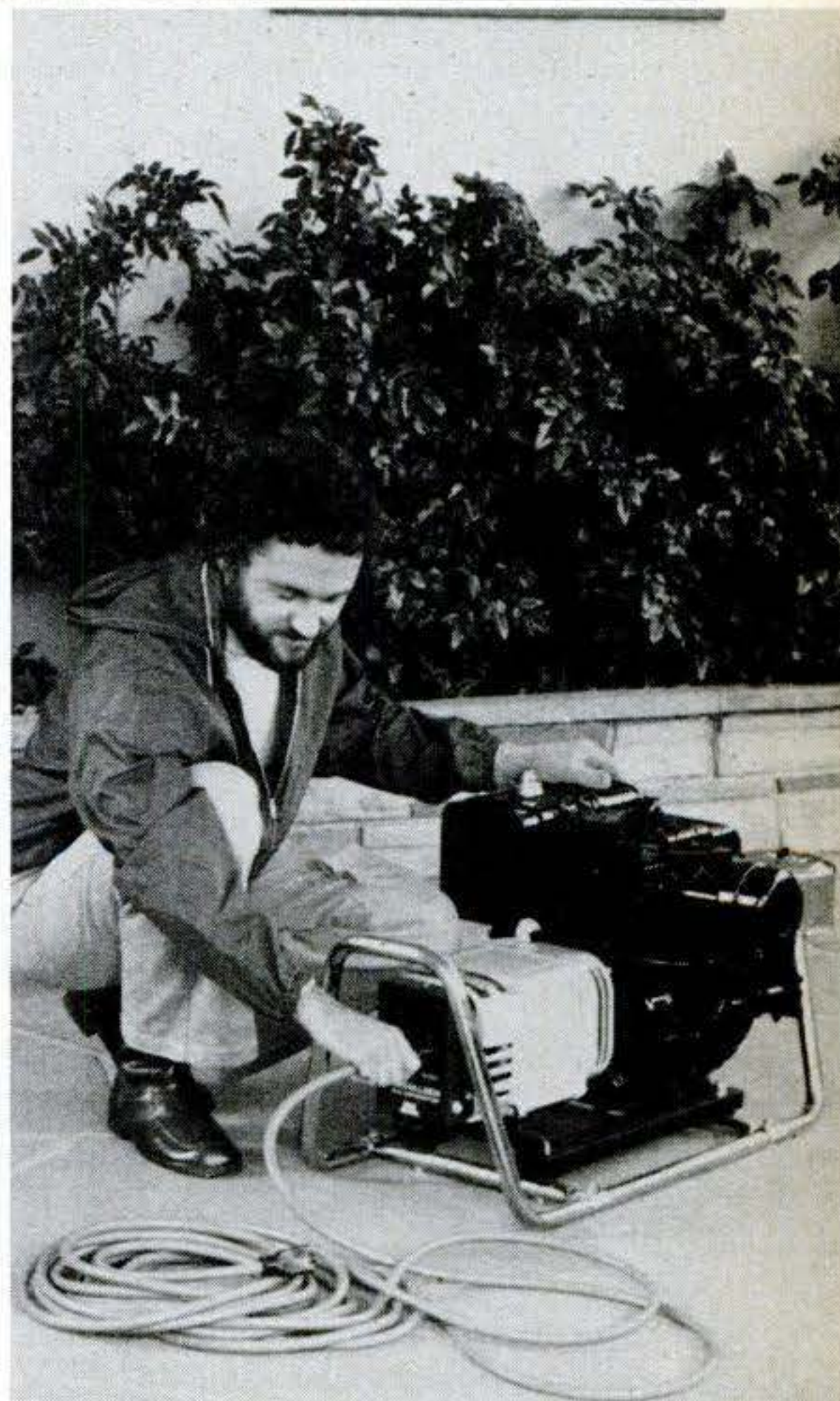

Good power source for yard chores is McCulloch's Handy Power 5000 generator.

What's New

A PICTURE ROUNDUP OF NEW PRODUCTS AND DEVELOPMENTS



UH-60A helicopter

Army paratroopers rappel into rough terrain from a Blackhawk UH-60A twin-turbine helicopter. The new Sikorsky craft has a tilted tail rotor and a huge tail plane to aid hovering stability. Made with special lightweight materials, UH-60A can carry 11 men and a crew of three.

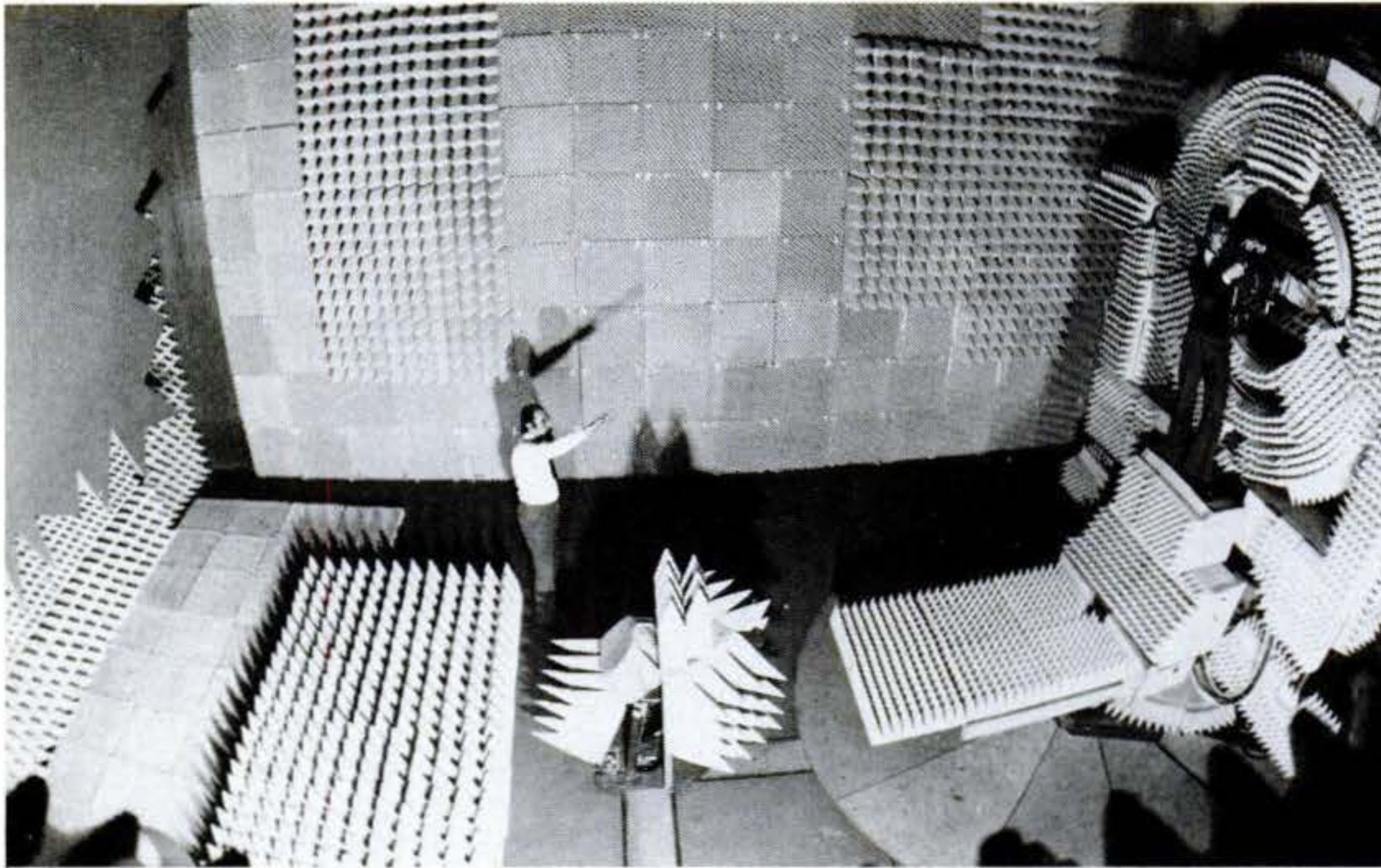

Microwave chamber

This huge anechoic chamber has carbon-loaded plastic-foam spikes that absorb stray microwave radiation. The "tunable" panels enable British Aerospace Dynamics researchers to test radar components in a 23-by-42-ft. room. Previously, great distances outside were required.

Future truck?

Twenty-first-century truck? Front-end shapes on future trucks may not change much, according to International Truck—unless revised laws permit front-axle changes for aerodynamic improvements. This experimental model was made to test wind resistance of a streamlined frontal area.

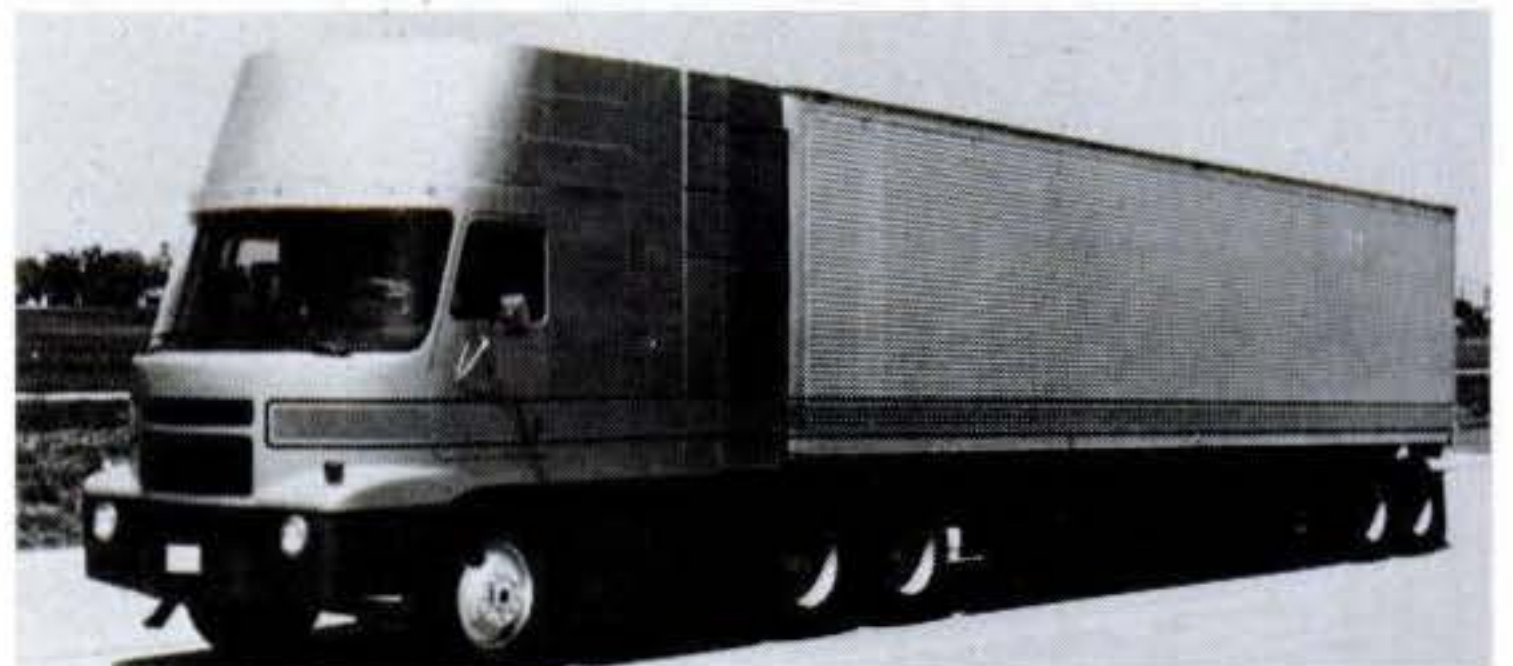

Fuel saver

An improved fanjet engine that's quieter, more fuel efficient, and powerful is retrofitted to a Boeing 707. The new 22,000-lb.-thrust engine, made by CFM International, cuts fuel consumption 14–18 percent over 18,000-lb.-thrust JT3D power plants in use on 707's and DC-8's.



Conte amphibian

Twin stern propellers, powered by individual hydrostatic motors, push this \$36,000 German Conte amphibian through the water. On land, its 114- or 135-hp V6 drives the back wheels instead of a marine pump. Maker: Herzog, 6239 Kriftel, Elizabethenstrasse 3, Germany.



Efficient wing

A new look in light-plane wings appears on an experimental Dornier TNT aircraft. The twin-engine STOL was modified in Germany to test high-efficiency wings. This lightweight-wing design, with backswept tips, promises 50 percent range boost, 25 percent shorter takeoff.



Hydroponic dome

For fresh vegetables throughout the year, Aqua-Terrarium, a heated hydroponic unit, helps you grow plants without soil. Nutrients are circulated through an inert medium. Enclosure's Uvex-plastic dome aids plant lighting. Harvest Home, Inc., 8625 126th Ave. N., Largo, Fla.

Fiat hatchback

Lancia Delta is a classy cousin of the Fiat Strada, but shares only its front-drive transverse engines and gearbox. The car has an all-new hatchback body, with front and rear independent suspension for ride comfort plus sporty handling. Engine options: 75 and 85 hp.

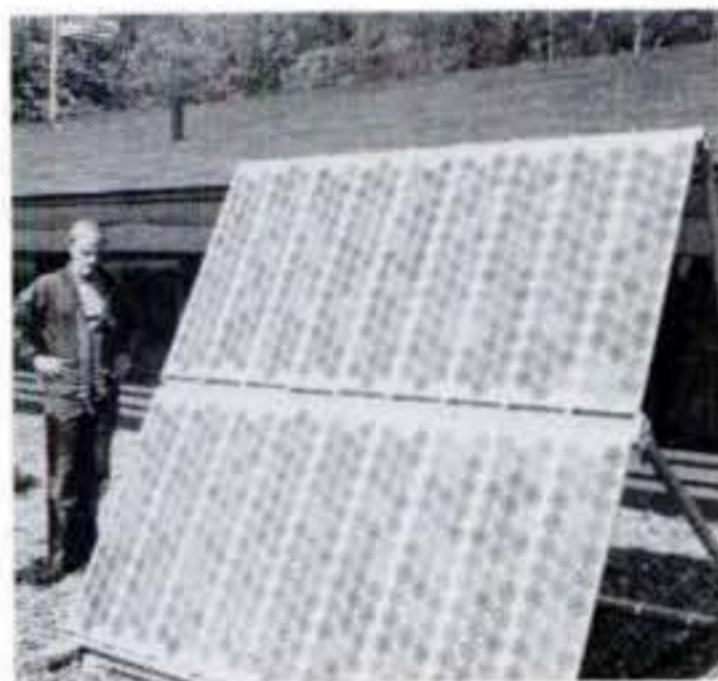

Olympic power

Solar-cell panels like these supplied electricity for communications at this year's Winter Olympics in Lake Placid, N.Y. Twenty photovoltaic panels, made by Arco Solar and others, powered telephone and radio links between officials at the base and peak of ski trails.

Fun boat

Circraft is a boat for water fun that needs no steering gear. Made in North Wales, it has the circular shape of old Welsh craft. You steer the motor-driven boat by holding the handrail and leaning to the left or right. A 35- to 40-hp outboard is used; a 40-hp engine propels the craft up to 40 mph, or it can tow a water skier. The only control is the engine throttle. The craft holds two, is seven feet in diameter, and weighs 150 pounds without the engine.

Two foam-filled buoyancy tanks in the stern make Circraft practically unsinkable. When not in use, it can be conveniently stacked endwise. Jonval Marine Services Ltd., Abercegin House, Port Penrhyn, Gwynedd, N. Wales.

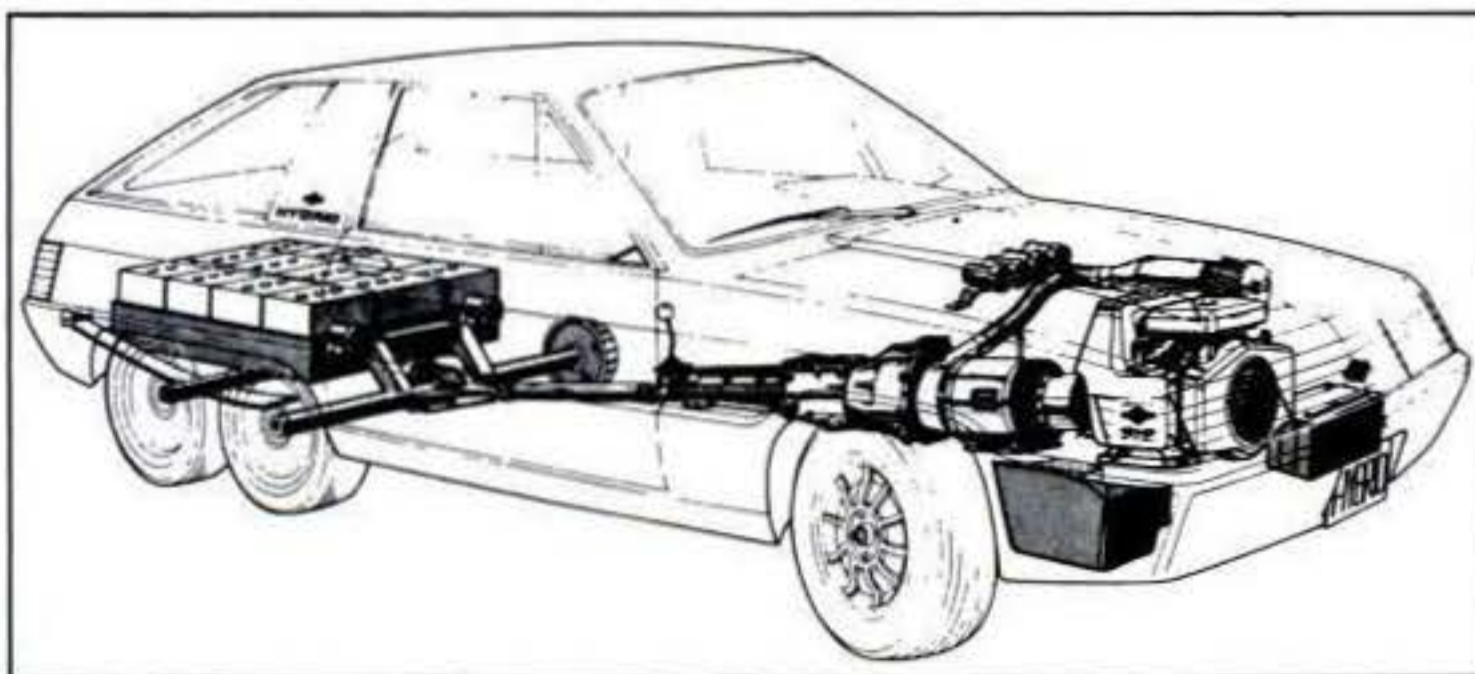

Hybrid electric has six wheels

Battery-powered cars are bad news when the cells completely discharge halfway home. But with Briggs & Stratton's hybrid vehicle you can switch over to an 18-hp B & S gasoline engine. The experimental car also runs on both electric motor and gas engine together, extending speed and power. Hybrid-power speed is 55 mph; a battery charge takes you 30-60 miles, and a gas-tank fill-up extends cruising range to 280 miles. The half-ton battery pack rides a "captive trailer" on two rear wheels. The engine/motor combination drives two middle wheels, and the front wheels control the steering.



What's New

IN PHOTOGRAPHY

BY E. H. ORTNER



Auto-focus 35's: two systems

Just frame and shoot with the Minolta Hi-matic AF or Canon Sure Shot AF35M. Both offer automatic focusing, automatic exposure, and built-in flash. Minolta uses the Honeywell Visitronic auto-focus system [PS, Dec. '77]: Light-sensitive detectors compare the two images entering its rangefinder and halt the moving lens when the images exactly coincide.

Canon's system simultaneously sends out an infrared beam and starts the lens moving. When the beam, locating the object, is reflected back at greatest intensity, the lens halts—in focus. The Minolta is \$240. The Canon, with motorized film advance and rewind, is also \$240.

Rain guard

Poke the lens of your camera into the front extension of the Ewa Cape, and the heat-sealed plastic hood will protect the camera from rain and splashes. Price of the unit: \$9.95. U.S. distributor: Pioneer & Co., 216 Haddon Ave., Westmont, N.J. 08108.



110 flash

Now there's a new and even smaller flash to go with the tiny Pentax Auto 110 SLR pocket-camera system: the 3½-oz. AF-100P. It delivers up to 150 automatic flashes from two AAA cells. Price is \$39.

Two-headed flash

Two heads help the Hanimex TS855 give a variety of light effects. One swivels and bounces, and both turn off after each shot to save power. The thyristorized automatic flash comes with wide-angle and tele adapters, and four colored filters. Its price: \$125.



Cable switch

For owners of the Konica FS-1 SLR, now there's a three-foot coiled-cable release with an electro-mechanical micro switch. The cord enables the camera to be operated remotely, for studio or other photography, with the camera on a tripod. It's \$18.



Tilting projector

Need to tilt your projector to shift its aim? The Tilt-Pro stand does it quickly and easily, says its distributor, Tilt-Pro Sales (4113 Ortisi Dr., Orlando, Fla. 32807). The unit holds a heavy projector, yet folds flat for storage. It's \$51.45 ppd.



What's New IN BOATING

BY SUSAN RENNER-SMITH

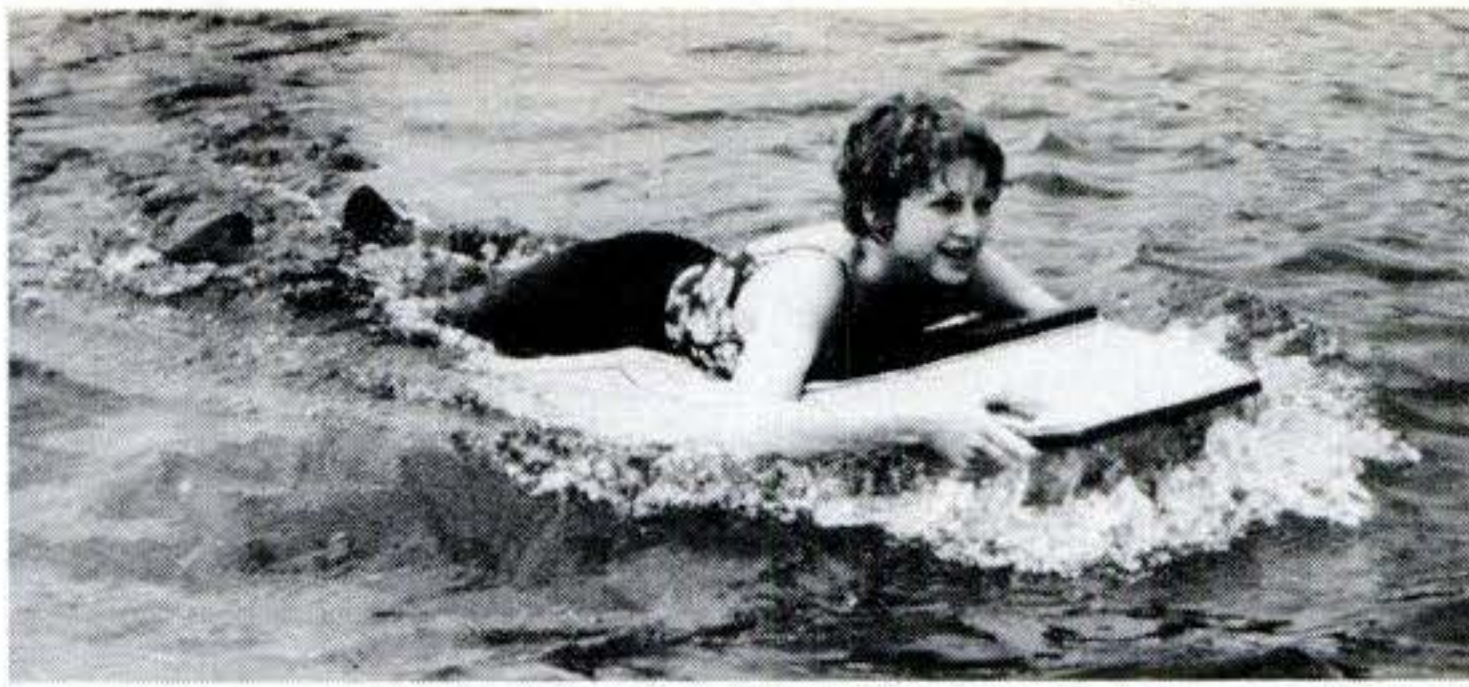

Scuba sled

Scooting along at five mph, the Sea Bee can ferry a 250-lb. diver to a chosen spot. A sealed 12-V battery runs the prop-driven sled for up to three hours. The flotation-filled plastic craft weighs 35 lbs., costs \$549. American Ventures, 4433 Touhy Ave., Lincolnwood, Ill. 60646.



Classy cruiser

Rigged for racing, the new Bombardier 7.6 carries 218 sq. ft. of sail. The handsome balsa-fiberglass hull is designed for comfort with a full galley, enclosed head, and cabin seating for six. Bombardier (Valcourt, Quebec, Canada) will market the 25-footer here in September.

Kevlar competitor

Stronger and lighter than fiberglass kayaks, these are made of an advanced new fiber—chemically activated polyester. It costs just one third as much as Kevlar but has only 10 percent less flexural strength, says the developer (Noah Co., Box 193B, Bryson City, N.C. 28713).

Chatty finder

It looks conventional—until it starts calling out numbers. The microprocessor-controlled TDS-1 has a synthesized voice that announces depths from one to 600 feet. The \$995 sounder gives extremely accurate readings, says Paragon Electronics (Box 1456, Bellevue, Wash.).

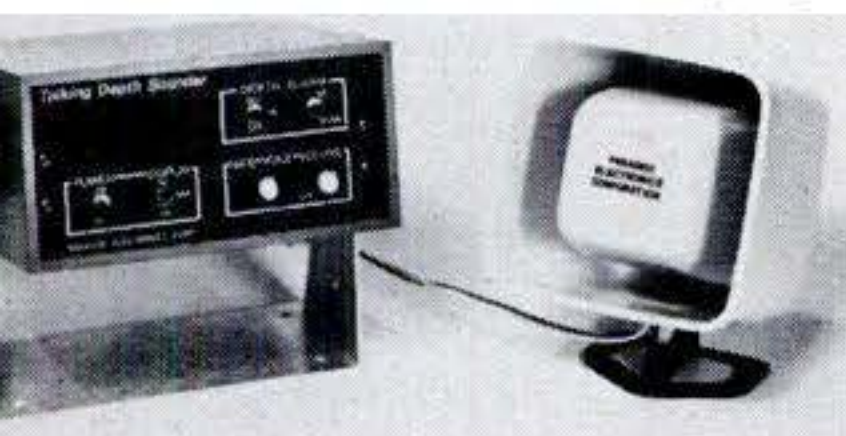

Smart Loran

The talented new Loran C Navigator from Texas Instruments cuts chart-checking chores. Its microprocessor converts Loran signals into latitude and longitude, updates the display each second. The \$3495 model also boasts a memory that stores data and settings even when the unit is off.

Catch cleaner

You can fillet fish without fouling the decks with the Fish-or-Cut-Bait Tray. It has a fish-sized, rotating wooden cutting board bolted to a sturdy, ribbed-plastic tray. The tray and its wooden legs detach quickly for storage. Cape May Tackle, Box 310, Vineland, N.J. 08360. \$165.

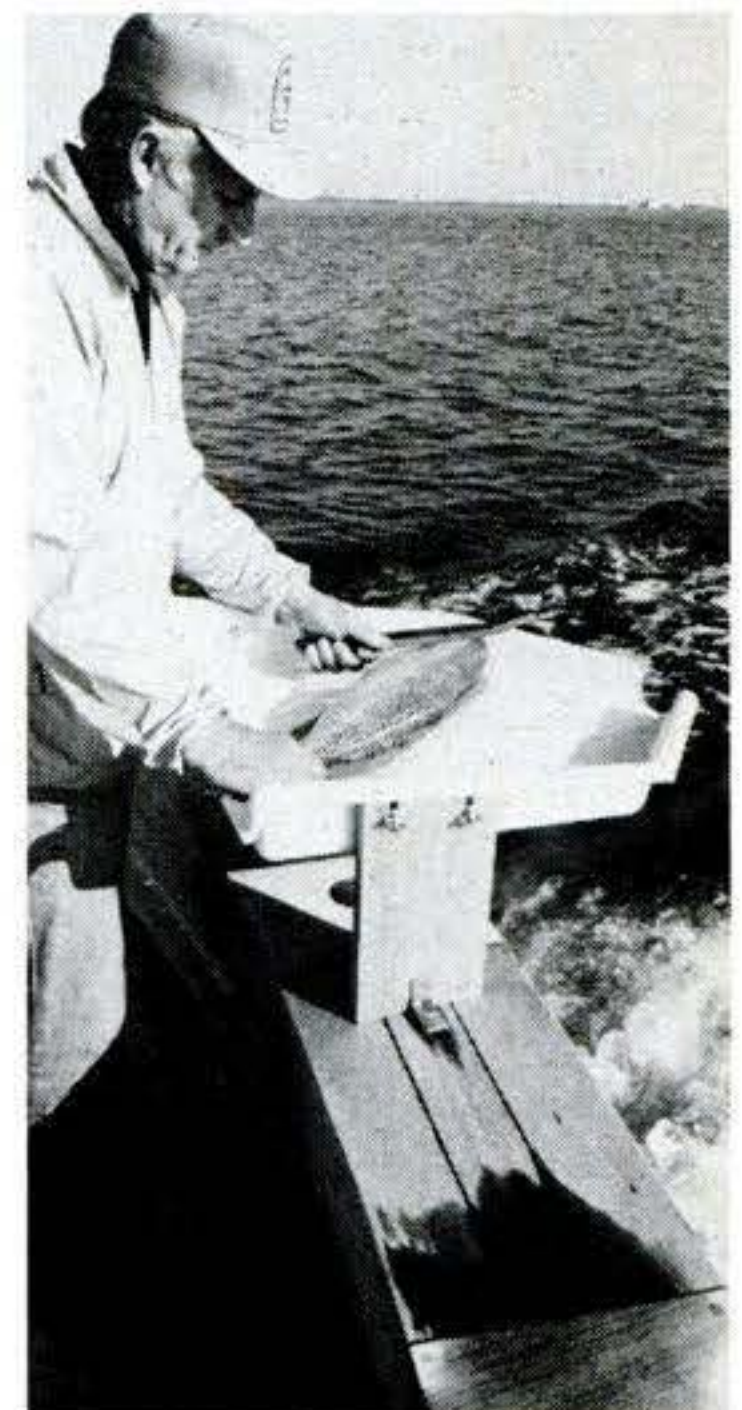

What's New

IN HOME IMPROVEMENT

BY R. L. STEPLER



Skylight

Tri-Therm's Lexan outer dome and two-layer inner diffuser give the thermal resistance of triple glazing. The skylight is offered in two sizes: 14 by 28 in. and 30 by 30 in. Faulkner Plastics (Box 11266, Tampa, Fla. 33610) says the units can be installed by do-it-yourselfers.



Remote controller

You can control appliances and thermostats when you're away from home by simply dialing your phone number, says the maker of Tele-Commander. A microphone in the device "listens" for a preset number of phone rings. G2 Enterprises, 255 W. 90th St., New York, N.Y. \$62.20.

Hot rack

This British-made, chrome tubular rack connects to central hot-water heating systems or domestic water heaters to make bath towels piping hot; an oil-filled electric model plugs into a 110-V outlet. Prices: \$135-\$278. Myson, Inc., Box 5025, Fredericksburg, Va. 22401.

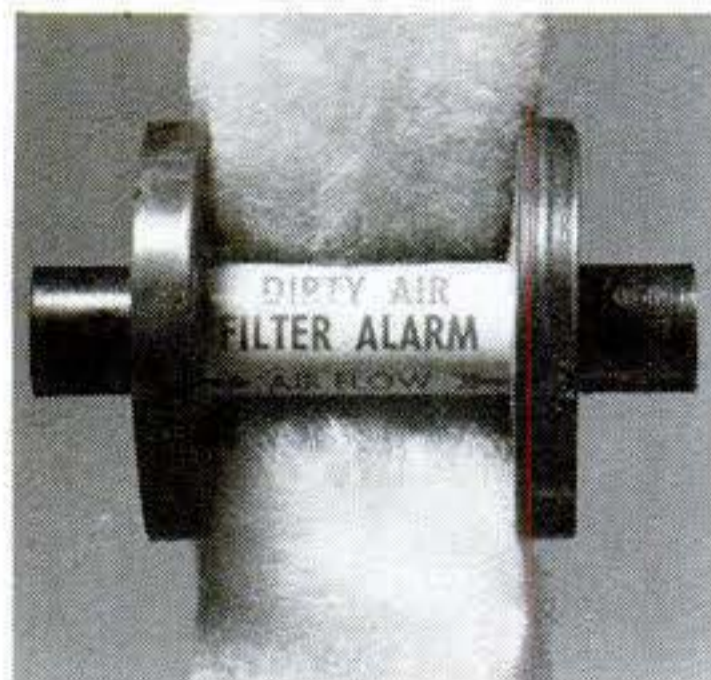

Air-filter alarm

Clogged filters cut your heating system's efficiency. The Dirty Air Filter Alarm mounts in the filter (shown cut away) and whistles as the filter becomes clogged, alerting you to clean or replace it. Price: about \$2. Williams Research, 24266 Walnut St., Newhall, Calif. 91321.

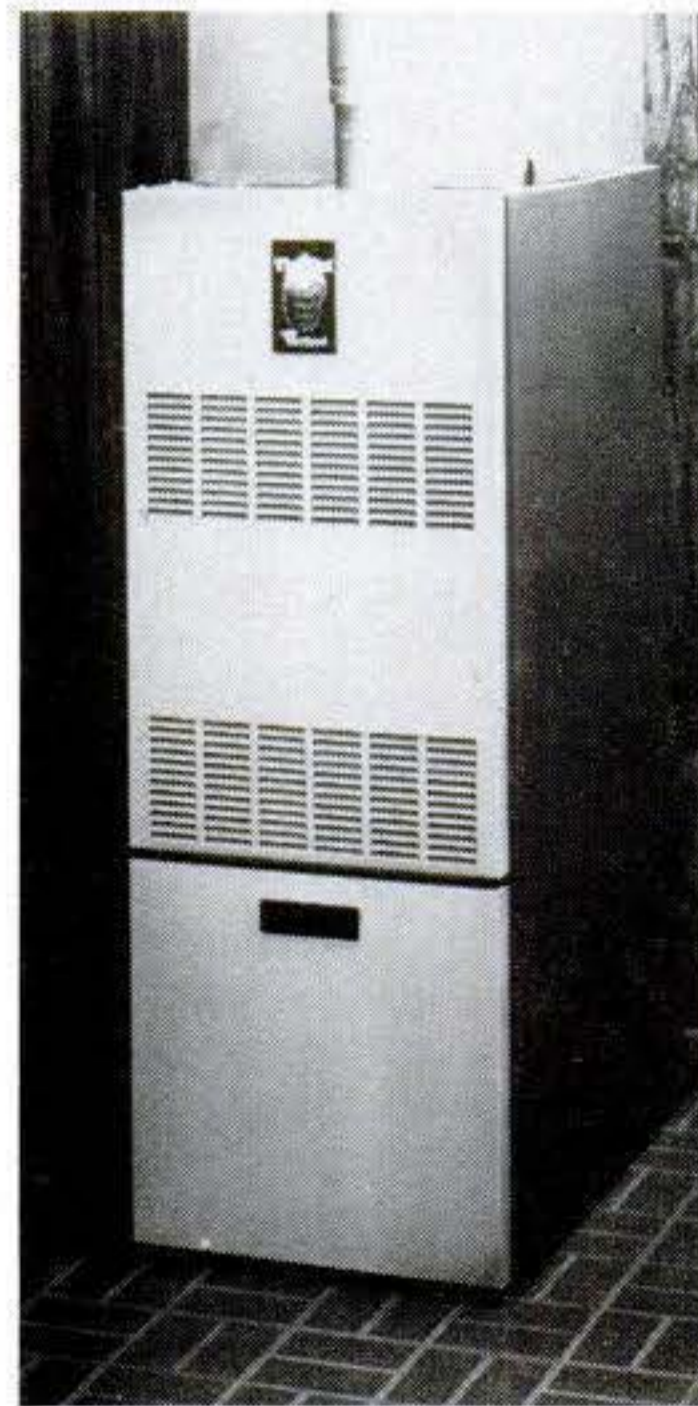

Miserly furnace

Whirlpool says its Tightfist gas furnace is 30 percent more efficient than standard units. Reasons: A blower pulls combustion air in, pushes flue gases out; only a three-inch-dia. flue is needed; direct spark ignition is used instead of a standing pilot light.



Air conditioner

The two-ton Premium Round One, boasts Carrier, has a seasonal energy-efficiency rating (SEER) of 12.0. Key features include an extra-large condenser coil; a high-efficiency compressor; a two-speed, automatically shifting fan; and a liquid-refrigerant accumulator.

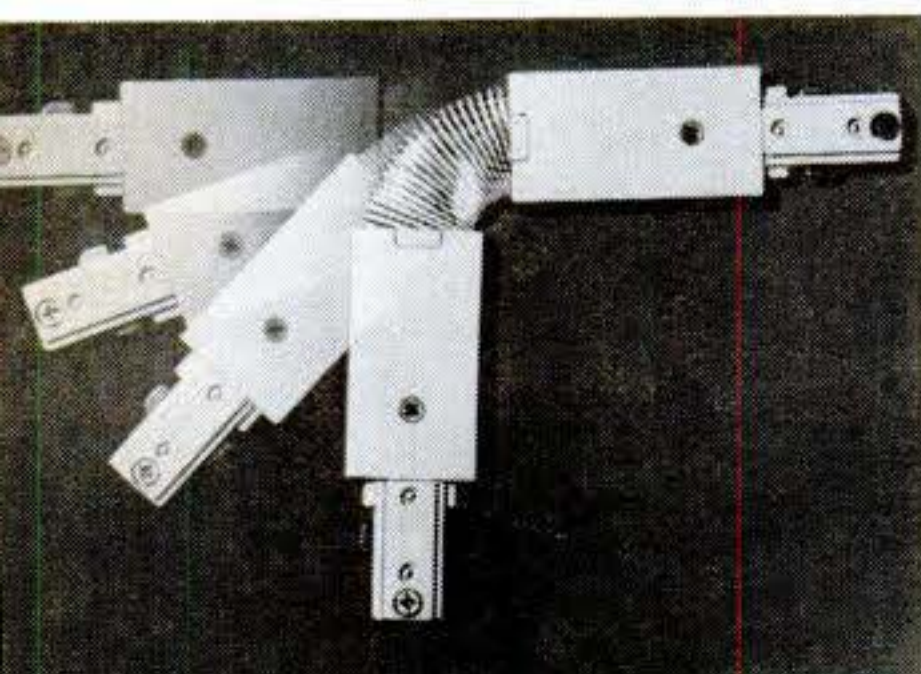

Track connector

Halo's Flexible Connector for track lighting bends up to 90 degrees to let you join ceiling- and wall-mounted tracks, or arrange tracks in almost any configuration. The connector fits Halo's Miniature Trac system for homes.

What's New IN TOOLS

BY R. L. STEPLER

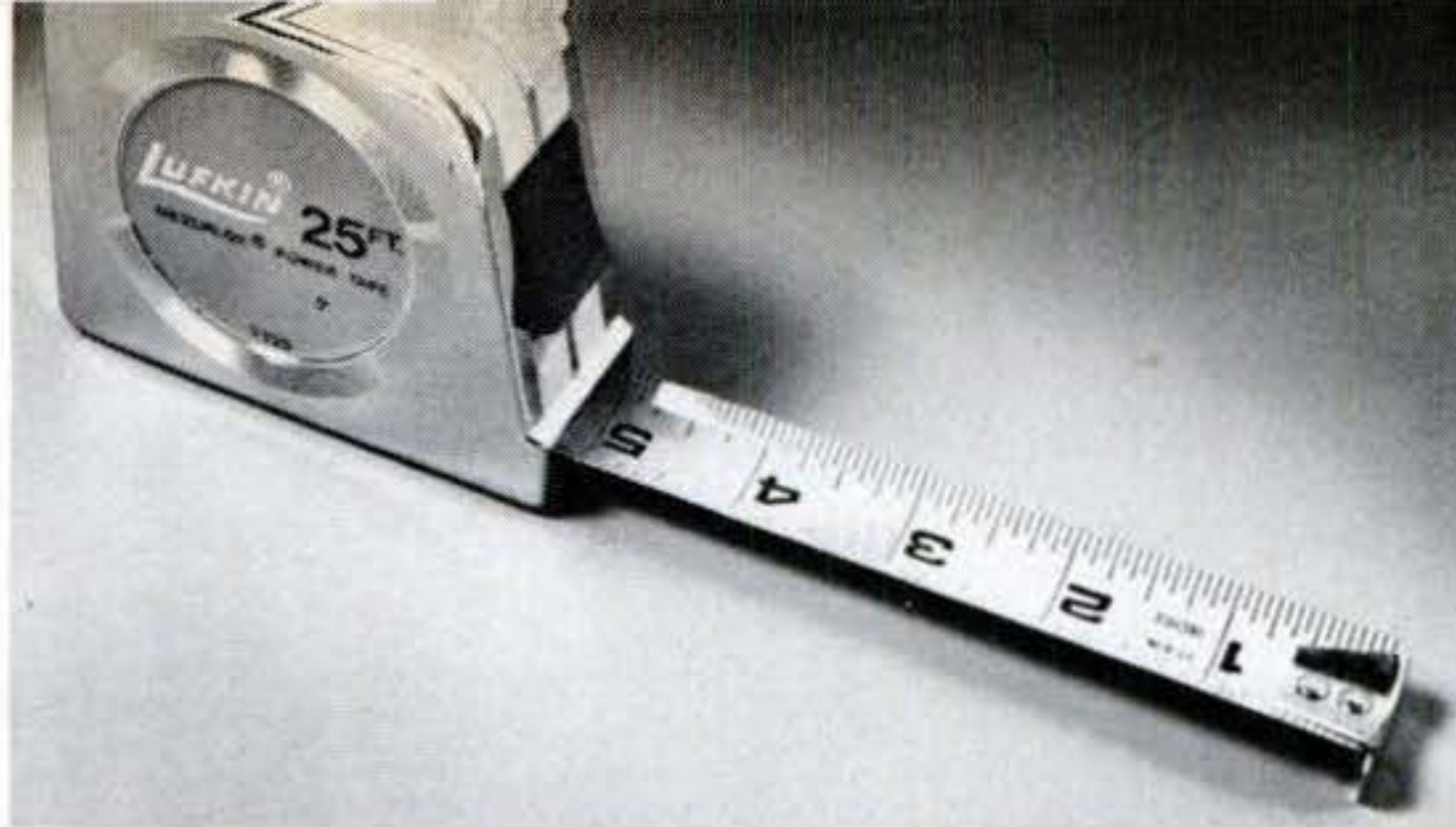

Big inch

It's one inch wide so you can make one-handed measurements to seven feet and more. That's what Lufkin says of its Mezurlok 16- and 25-ft. power tapes. Other features: yellow epoxy-coated blades with black markings, cushioned blade return, and no-creep toggle lock.

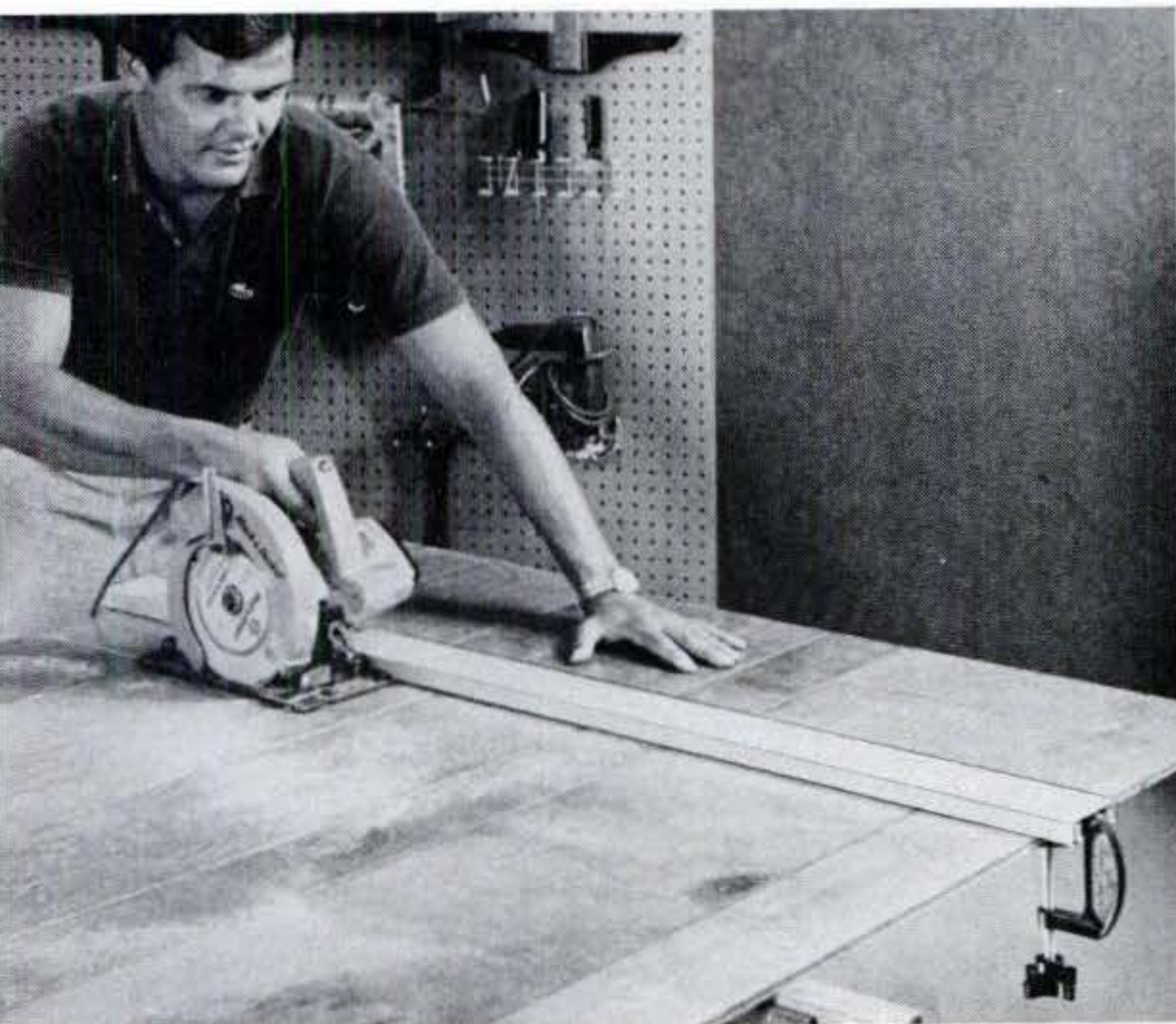

Cutting guide

Captive clamps fasten Mac-lanburg-Duncan's cutting guide directly to the workpiece to let you make precise cuts up to four feet long. An optional guidebar extends the length of the cut to eight feet.

Precision knife

Extremely fine cutting, trimming, and carving are possible with the Uber penknife, says Mason Associates (Box 384, Lexington, Mass. 02173). The instrument-quality tool is made of anodized aluminum, brass, and stainless steel. Price is \$8.95 with six blades.



Knuckle saver

Sprech turns a socket 90 degrees with every 11-degree squeeze of the handles. That eliminates knuckle banging and scraping in tight spots, says the Sprech Co. (21133 Costanzo St., Woodland Hills, Calif. 91364). The tool is 10½ in. long, costs \$21.95.



Power-tool kit

Four tools come in Wen's \$99.95 Task Force: the Hot Shot soldering gun; ¼-in. drill; ⅜-in. stroke jigsaw; and a 14,500-rpm power tool that grinds, sands, shapes, engraves, and more. The carrying case also holds a 12-V power-supply transformer and accessories.



Metric rod

This three-section polyvinyl chloride builder's rod extends to 3.6 meters (12 feet), and is divided into meters, decimeters, and five millimeters. Polyrod is colored bright "safety" orange for high visibility. David White Instruments, N93 W16288 Megal Dr., Menomonee Falls, Wis.

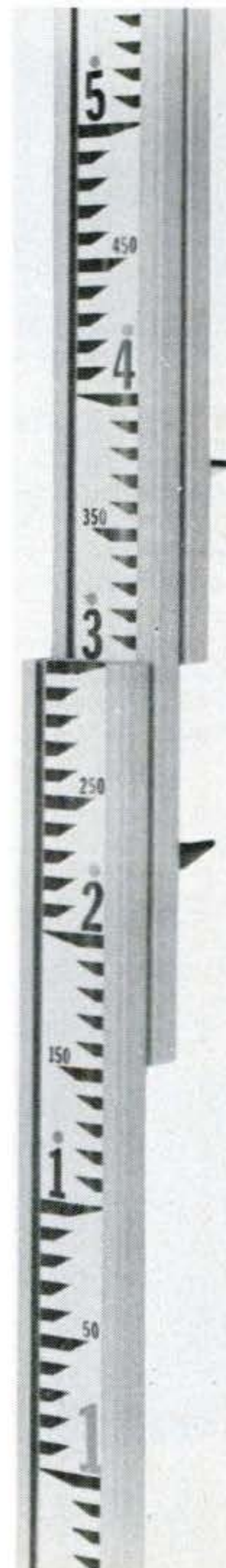

What's New IN ELECTRONICS

BY WILLIAM J. HAWKINS



Mobile computer

Route Commander is a totally portable computer system designed for on-the-road sales and delivery persons. It balances the books and keeps track of inventory, tolls, and parking; comes with keyboard, display, and printer. Norand, 550 Second St. S.E., Cedar Rapids, Ia. 52401.



Computer kit

Heath doesn't combine a 24-line-by-80-character "smart" terminal with a 5¼-inch disk, Z-80 microprocessor, and 16K or memory to come up with this all-in-one desktop computer—you do. It's a kit for \$1595 (or \$2295 fully assembled) from Heath Co., Benton Harbor, Mich. 49022.

Temp reader

Aim it at any surface, pull the trigger, and the digital display on this noncontact thermometer shows the temperature. It works from several hundred feet away and measures from -20 degrees F to 2000 degrees F. Raynger II is made by Raytek, 325 E. Middlefield Rd., Mountain View, Calif. 94043. \$1595.

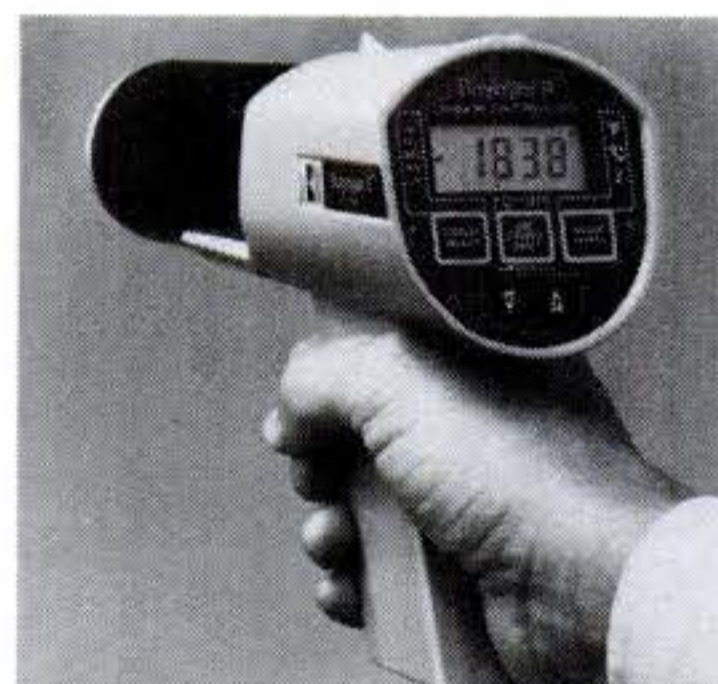

A light touch

A record is never perfectly flat or round. So, to track it properly, you need the lightest mass possible—this Onkyo CP-1030F does it by using a straight-line carbon-fiber tone arm that accepts high-compliance cartridges. Result: Even warped records can be played. Price: \$315.



24-hour tape

Got lots to say? The XLP4 cassette tape recorder is the only one that can record up to 24 hours of voice on one C-180 cassette. It runs at ¼ the normal speed and uses four tracks to do it. Made by Norwood (3828 S. Main St., Salt Lake City, Utah 84115), it's \$129.95.



Digital portables

Two new portable radios from Toshiba are totally digital: AM model at left (\$60) holds six preset stations in its memory; LED's show frequency. AM/FM clock radio at right (\$160) uses an LCD display to show frequency, time, and alarm time. A buzzer wakes you; six memories hold your station.

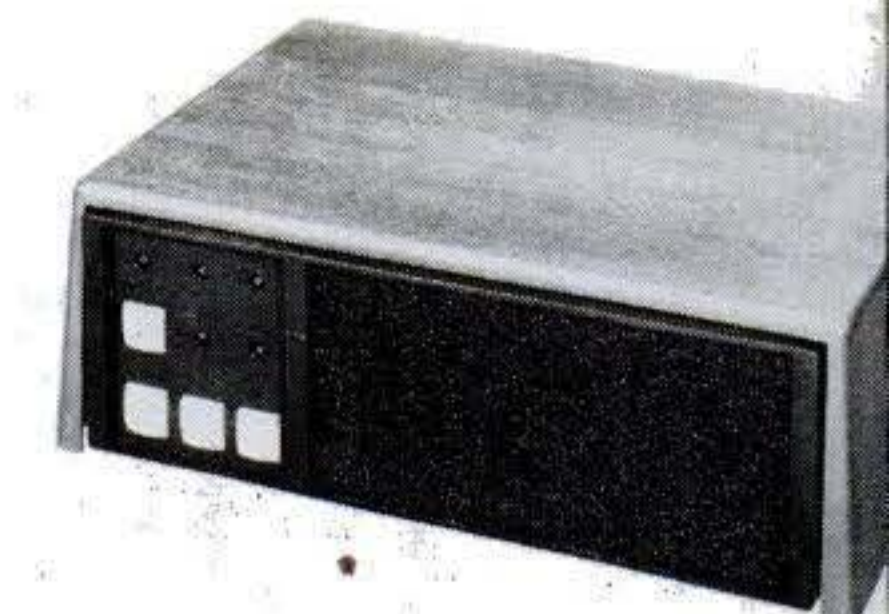

Coded alarm

Walk within 50 feet of Radio Shack's RF intrusion-alarm system and you'd better know the four-digit code to silence it. Not even a power failure will stop it from standing sentry in your home—it has a built-in battery backup. The Safehouse Alarm is \$179.95.

What's New FOR YOUR CAR

BY ED JACOBS



Lifetime air filter

The reusable LTF air filter traps dirt particles in an open-honeycomb foam maze treated with a special oil. To service it, you wash it in detergent and water, then re-oil—at intervals up to 25,000 miles. Price: \$12.50. Amsoil Inc., Amsoil Bldg., Superior, Wis. 54880.



Year-round tire

Firestone's Trax 12 is an all-season steel-belted radial with nearly 5000 gripping edges—about 50 percent more than conventional radial passenger-car tires. The aggressive tread design is said to improve starting and ability to stop on ice.

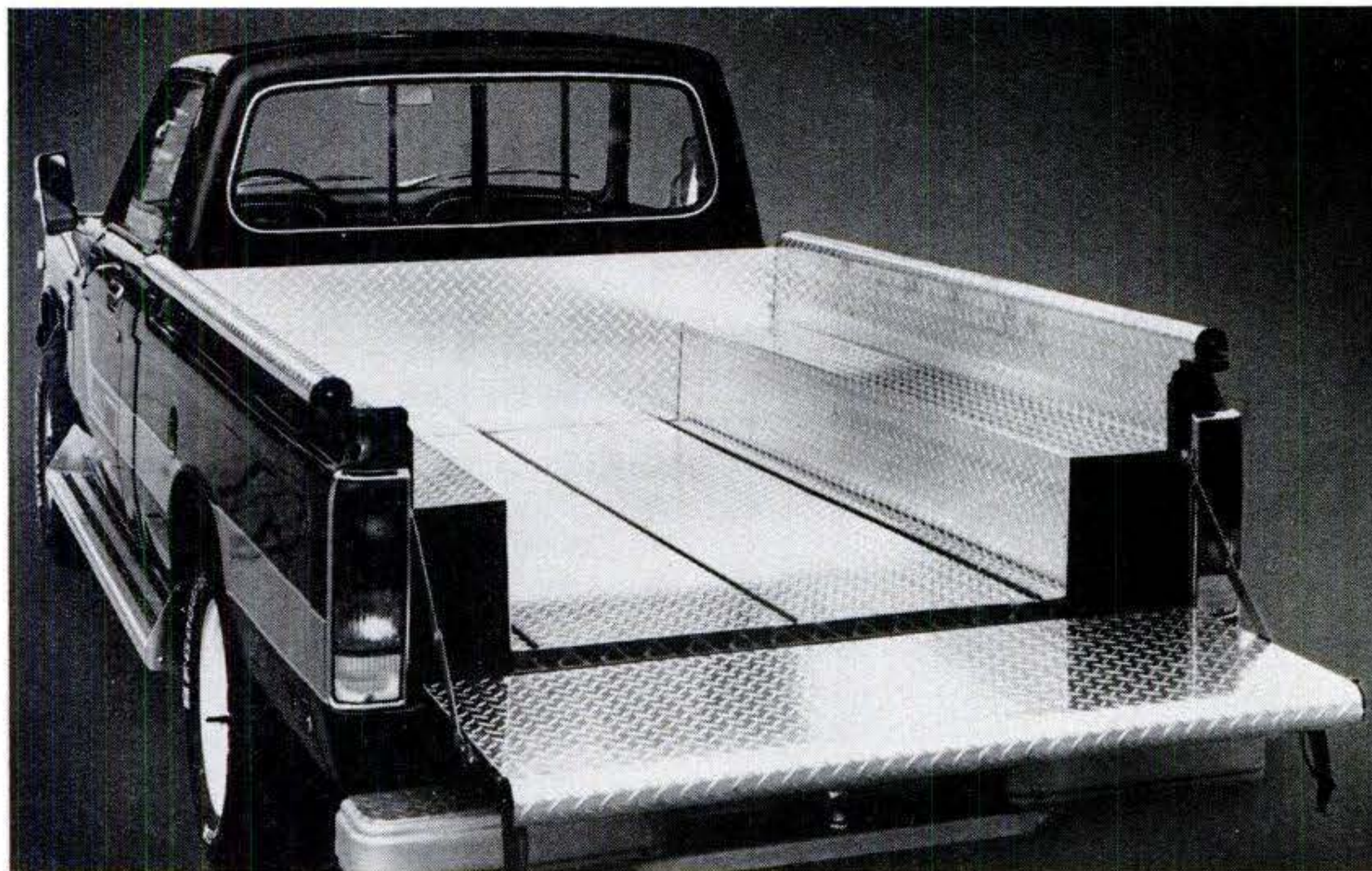

Bed protector

You can protect your full-size or mini-pickup with this kit from Owens-Classic, Inc., Box 628, Sturgis, Mich. 49091. Aluminum diamond-plate panels cover the bed and sides, and overhang the tops of the sidewalls. Installation requires only a drill and screwdriver.

4WD greaser

With Adapt-To-Lube, you can lubricate the front spindle bearings of your 4WD without removing major components. And you can use it with either a hand grease gun or pressurized system. \$16.95 from R&T Enterprises, Box 2225, Westminster, Calif. 92683.

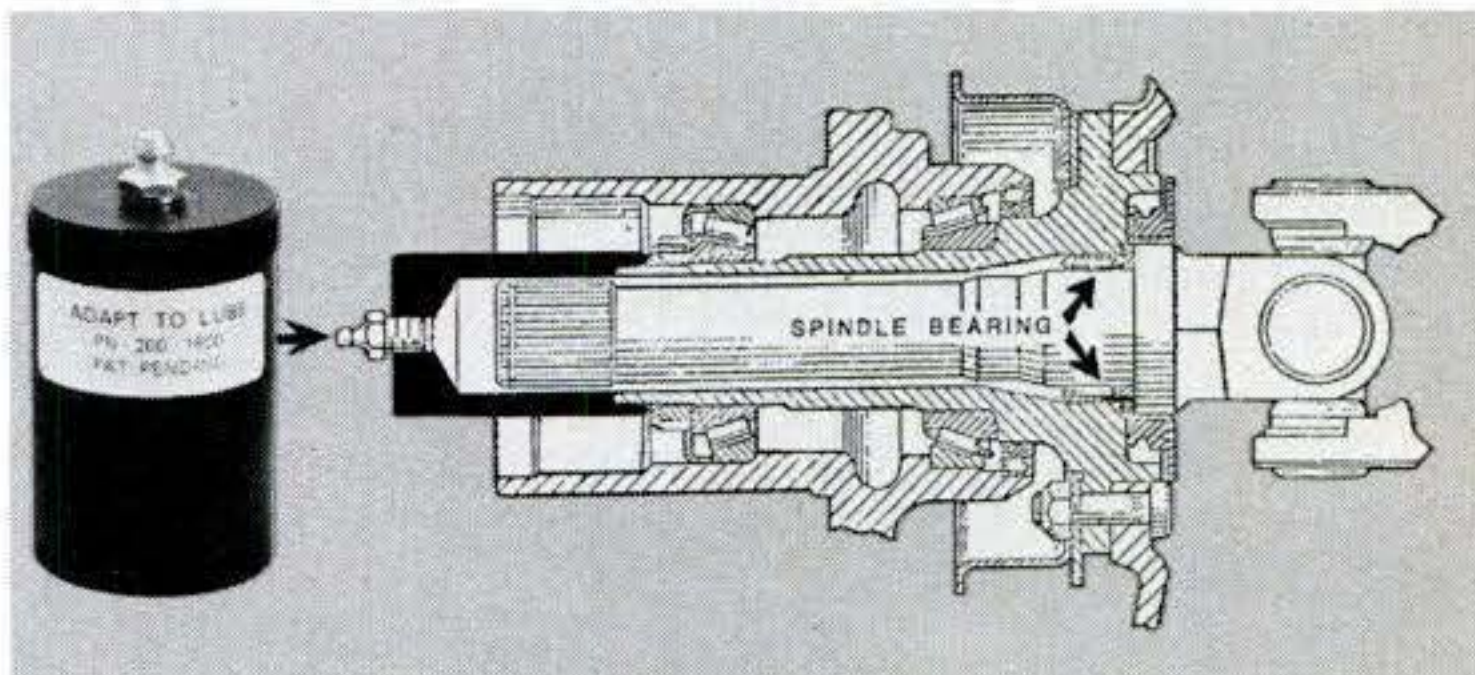

Washer-wiper

Slots in the rubber of this windshield-wiper blade automatically release cleaning fluid in front of the blade in both directions of travel to remove grime faster and eliminate waste. Safety Vehicles Development AB, La-hallsvagen 19, 183 50 Taby, Stockholm, Sweden.

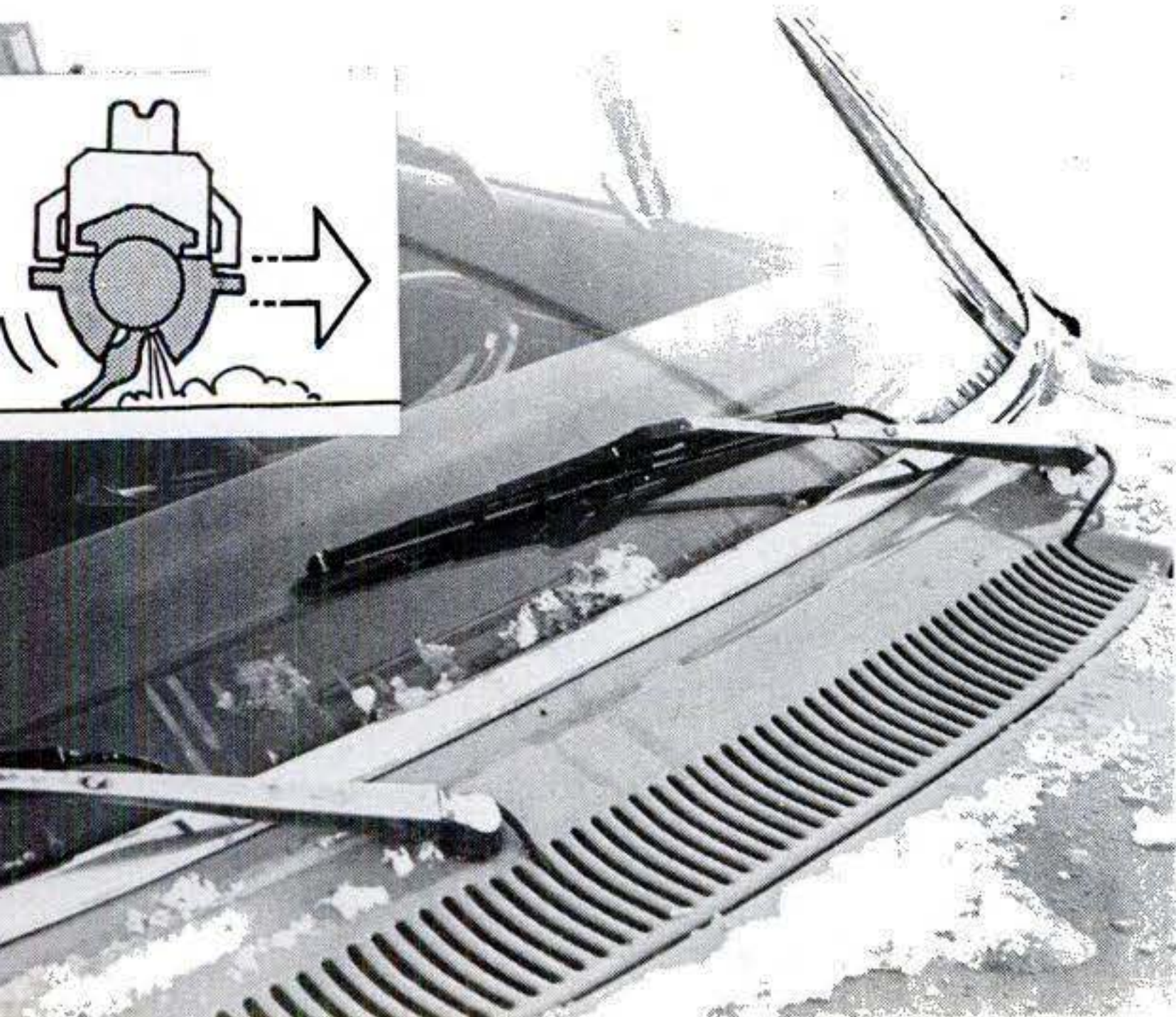

Fog/driving lights

Marchal's compact 750-series lights are available for either fog (yellow lens) or long-range driving (clear). They have lead-crystal lenses and use H-2 quartz-halogen bulbs. Price: \$41.90 each in chrome finish, \$38.90 in matte black, at local auto-parts stores.



'80 RV's

Here come the lightweights

Skyrocketing fuel costs are spurring a new generation of campers

By **HERBERT SHULDINER**

I stepped inside the Wilderness II, a European-looking travel trailer, and was astonished by its spaciousness and the number of built-in convenience features. The reason for my surprise is that the trailer weighs only 1650 pounds. Conventionally built trailers of that weight are tiny, cramped, Spartan vehicles.

The 19-foot Wilderness II, however, is a full-size trailer—one of the new generation of lighter, more-fuel-efficient recreational vehicles designed for the gasoline-starved '80s. I previewed these new RV's recently at industry shows in Los Angeles and Louisville, Ky., where the trend is clearly to more miles per gallon for trailers and motor homes.

RV manufacturers are striving to increase fuel economy and reduce fuel costs with a great number of innova-

tions. Honeycomb construction, hollow-core doors, trimmed-down dimensions, and smaller holding tanks are some of the elements that help reduce weight in this year's RV's. More aerodynamically efficient shapes cut wind drag and also help increase mpg. And there's growing use of diesel engines, overdrives, and dual-fuel (propane/gasoline) systems to cut fuel costs for RV's.

"We had to throw away traditional ideas and start from the ground up," says Elden Smith, vice-president of Fleetwood Enterprises, builder of the Wilderness II and two sister models, Taurus 2000 and Prowler LT.

"Our goal was to build the largest possible trailer that could be pulled by one of GM's new smaller X-body compacts," Smith says. Since the maximum towing weight of the X-bodies is 2000 pounds, the trailers had to be even lighter to accommodate clothing, food, water, and cooking and heating fuel.

Fleetwood examined every part of the trailer structure in an attempt to save weight. Says Smith: "We asked

ourselves—Does everything have to be there?" This led to the elimination of most outriggers in the trailer chassis and a reduction in the amount of steel used there—without diminishing its structural integrity, Smith claims. The trailer is about a foot narrower than most RV's. Its walls are much thinner—one-inch, instead of 1½–1¾ inches in conventional trailers. A lamination of wood, fiber-honeycomb, and fiberglass gives the walls sufficient strength, yet requires fewer structural members. And the same thing was done to the floor and roof.

In addition, lighter furnaces, ranges, stoves, and other appliances were used. Holding tanks were reduced in size—20 gallons instead of 30. Even lighter-weight upholstery and carpeting were used. Furniture springs were substituted for plywood to support gaucho and dinette cushions, which also saved weight. And an aluminum propane tank was used in the Wilderness II instead of a heavier steel container.

Fleetwood performed wind-tunnel tests to improve aerodynamics. Smith told me the exterior design that resulted has 60 percent less drag compared to trailers that have blunt frontal areas.

Besides its 19-footers, Fleetwood builds 22-foot models of the same trailers using the same construction techniques. They weigh only 1800 pounds—also about half the weight of most trailers that length. They're too heavy for the X-body cars, but well within the towing capacity of intermediates.

Other major companies to introduce new lightweight trailers are Winnebago and Shasta. Their units, however, achieve weight saving to a great

Continued



Build it from a kit or buy it complete, the Burro is a modern-looking 13-foot light-

weight at 980 pounds. The kit costs \$3185. Assembled, it's \$4250.



Upgraded Gettysburg fold-down trailer from Coleman sleeps seven. It features improved interior decor, bigger cooktop, and

larger dinette. Gettysburg weighs 1150 pounds and can be towed by new compacts. Prices start at about \$2875.



New lightweight 16-footer is Shasta's Ultra. A lighter, high-strength frame and new materials help keep its weight to 1395 pounds. Base price ranges from \$3525 to \$3695.



Most radical weight-shrinking effort was accomplished by Fleetwood Enterprises for this Wilderness II 19-foot travel trailer. It weighs just 1650 pounds—half the weight of standard units.



Smallest travel trailer ever from Starcraft is new Starlette, which comes in 15- and 17-foot (shown here) models. It's designed for towing by intermediates and costs about \$4000.



Slick new Apache Cub camping trailer has a top that is actually a three-seat boat. Trailer body can also be used as utility trailer when you remove bed board and tent. Price is \$1695.



New Winnebago LLT 16-foot trailer is designed for towing by new small compacts. It weighs less than 2000 pounds and stands only seven feet, five inches high. Prices start at \$4024.



More mpg and cheaper fuel costs are possible with overdrive and dual-fuel gasoline/propane options available on 1980 South-

wind 32-foot motor home. With two options, it's about \$27,600. Manufacturer is Fleetwood Enterprises.



New 10½-foot Sunline Sunspot can be pulled by smallest cars. With galley and holding tanks, it's \$2295; sleeps two.



Honeycomb construction in Diamond's 20-foot GT Mini Home shell cuts weight by about 20 percent. Base price: \$14,500.

extent by a reduction in length. Thus they have less interior living space than the Fleetwood lightweights.

All of these lightweight trailers, however, are still much too heavy for owners of subcompacts—a fast-growing segment of the U.S. auto population. Even most fold-down tent trailers are too heavy to be pulled by small cars. Are any RV's suitable for towing by the tiny cars? Just a few.

One of the cleverest is Apache's new Cub model. Light enough (860 pounds fully loaded) so that it can easily be pulled by any car sold in the U.S., it offers adequate basic shelter and galley needs—and its top becomes a three-seat boat.

Another innovative model is the Conway Cottage Camper. Fully loaded, it's 880 pounds, and that can be

towed even by a Honda, the maker claims. It folds out into an attractive-looking two-room tent, has a complete galley, and sleeps seven.

It's a lot easier for RV builders to shave weight in trailers than in self-propelled camping vehicles. That's because it's illegal to carry passengers in trailers, and these vehicles require a minimum amount of crashworthiness. Motor homes are a completely different story, however. They require considerable crashworthiness, so their makers can't sacrifice passenger protection just to save weight. Despite this, some weight reductions have been made. Holiday Rambler, for example, has managed to reduce the weight of its 22-foot mini motor homes by about 400–500 pounds over the last two years.

Perhaps the most outstanding example of motor-home shrinking among the 1980 models was achieved by Coons Manufacturing Co. in its Diamond 20-foot GT mini. With the use of honeycomb walls, about 50 percent reduction in the weight of the RV's shell was achieved. The skin makes up about 25 percent of an RV's weight, says Bud Coons, president of the company. With other weight-reducing contributions, the total weight was reduced about 20 percent. **PS**

WHO MAKES 'EM

(Apache Cub) Vesely Co., 2101 N. Lapeer Rd., Lapeer MI 48446; Burro, Inc., 14143 21st Ave. N., Plymouth MN 55441; Coleman Gettysburg, Box 111, Somerset PA 15501; Conway Trailers, 23878 County Rd., Elkhart IN 46514; (Diamond) Coons Manufacturing, Inc., 2300 W. 4th St., Oswego KS 67356; (Wilderness) Fleetwood, Inc., Box 7638, Riverside CA 92523; Shasta, 1423 Lincolnway E., Goshen IN 46526; Southwind, Box 7638, Riverside CA 92523; Starcraft, Box 338, Topeka IN 46571; Sunline Coach Co., RD 1, Denver PA 17517; Winnebago Industries, Box 152, Forest City IA 50436.



Tiny four-by-eight-foot box above opens into spacious two-room tent (right). The Conway Cottage Camper is a British design. It sleeps seven persons. The price is \$2495.





PS leisure-home plan

Woodstove cottage

By AL LEES

This ruggedly styled, two-story retreat was especially designed to be heated by an efficient wood stove. And its compact floor plan (right) contains still other energy-saving features. Created for PS by architect Samuel Paul—who calls it The Timbers—the house is shaped to funnel the stove's heat upward to the second-floor bedrooms. As shown in the interior view below, wood louvers across the top of this wall let the heated air flow into these rooms and the upstairs bath.

[Continued on page 180]

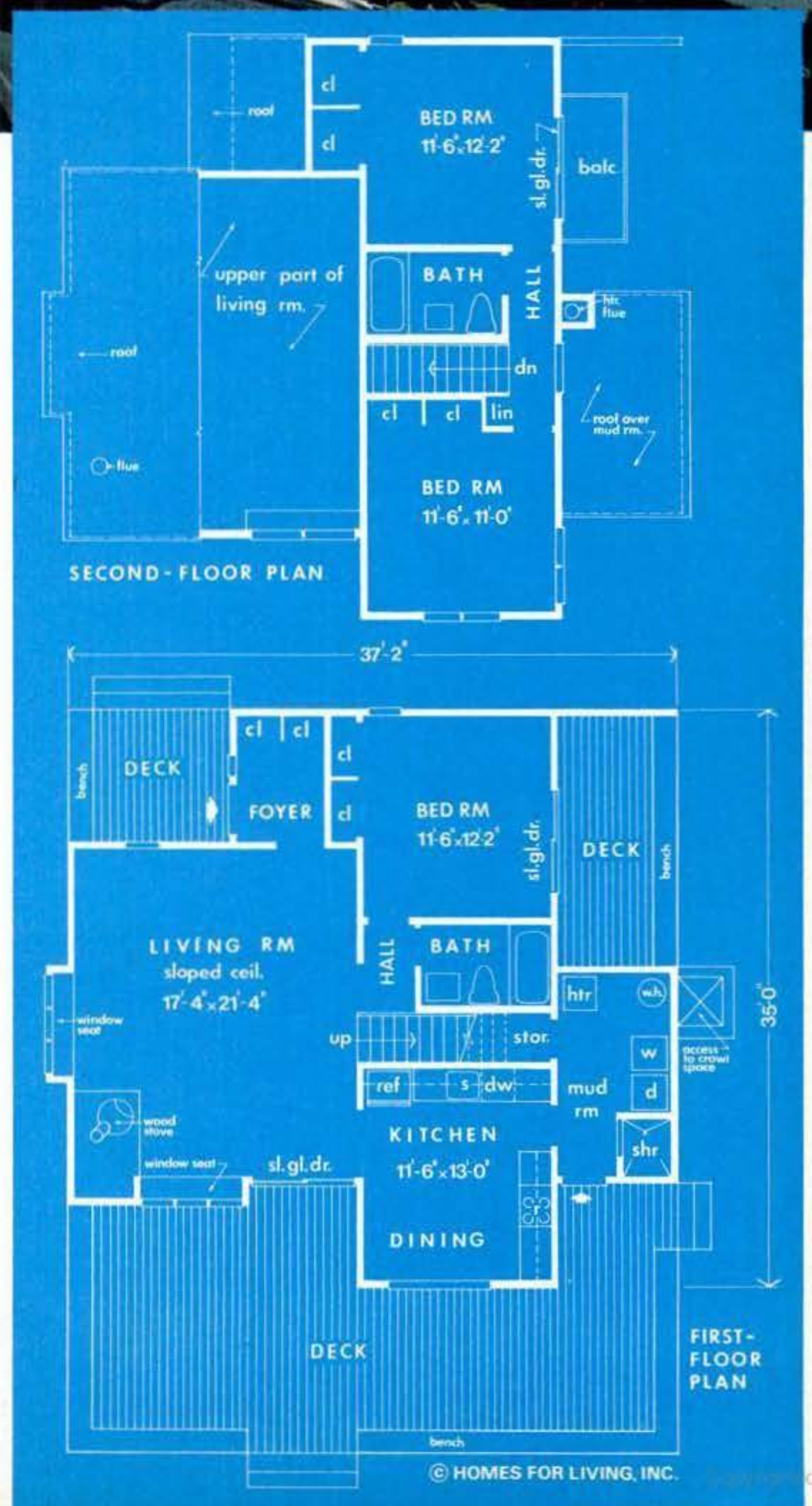

\$2000 GRAND PRIZE

PARMA TYSON, Hotchkiss, Colo.

Here are the 10 winners of our FRP PROJECT CONTEST

Since fiberglass-reinforced plastic panels now come in such a variety of colors, types, and rib shapes, adaptable to a wide range of home improvements, PS decided to sponsor a design competition, with the prize money put up by the leading manufacturer of FRP, Filon. We announced the contest last April, and showed examples of good-looking FRP projects we'd featured in past issues.

The response was most heartening. When I traveled to Filon's California headquarters to superintend the judging, I found a wealth of submissions in most of the five project categories I'd set up. Working with Filon repres-

Continued

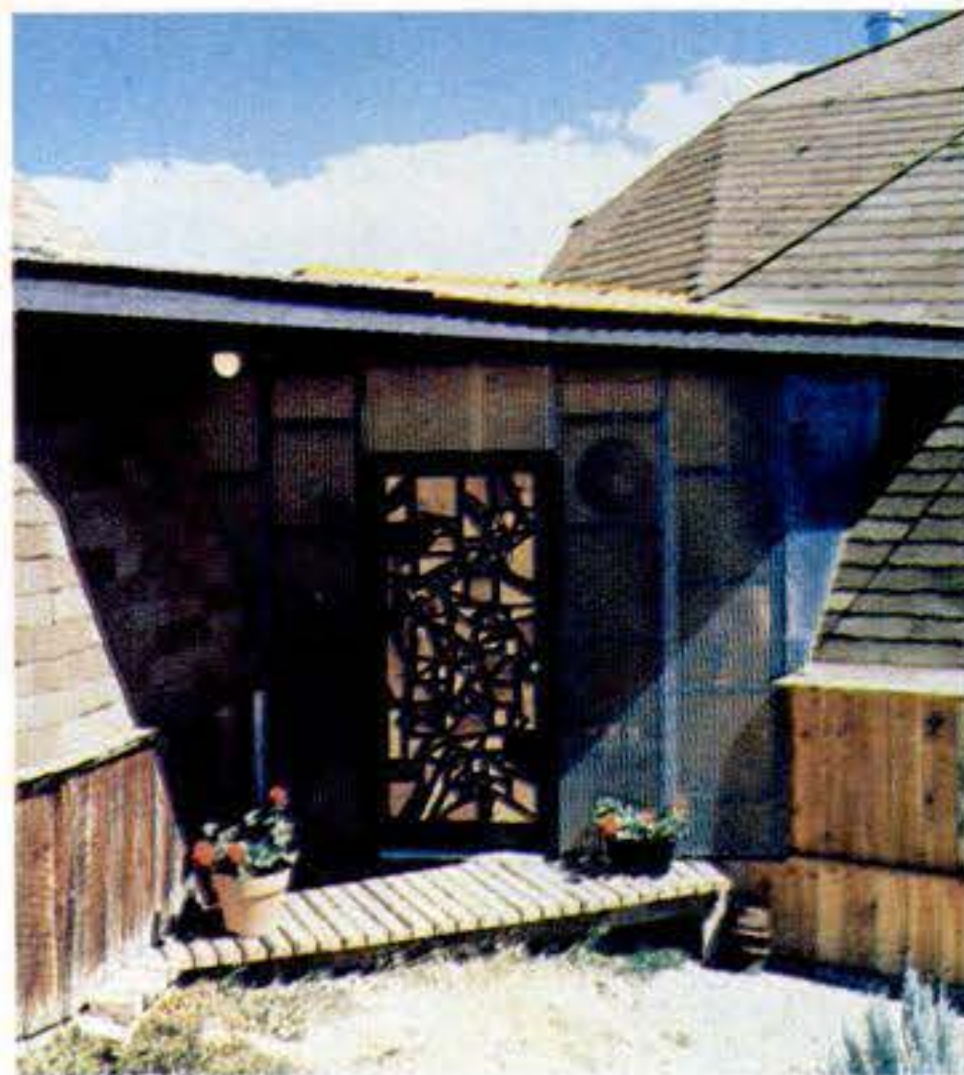

Both walls and roof of this breezeway connecting two domes are of FRP panels.

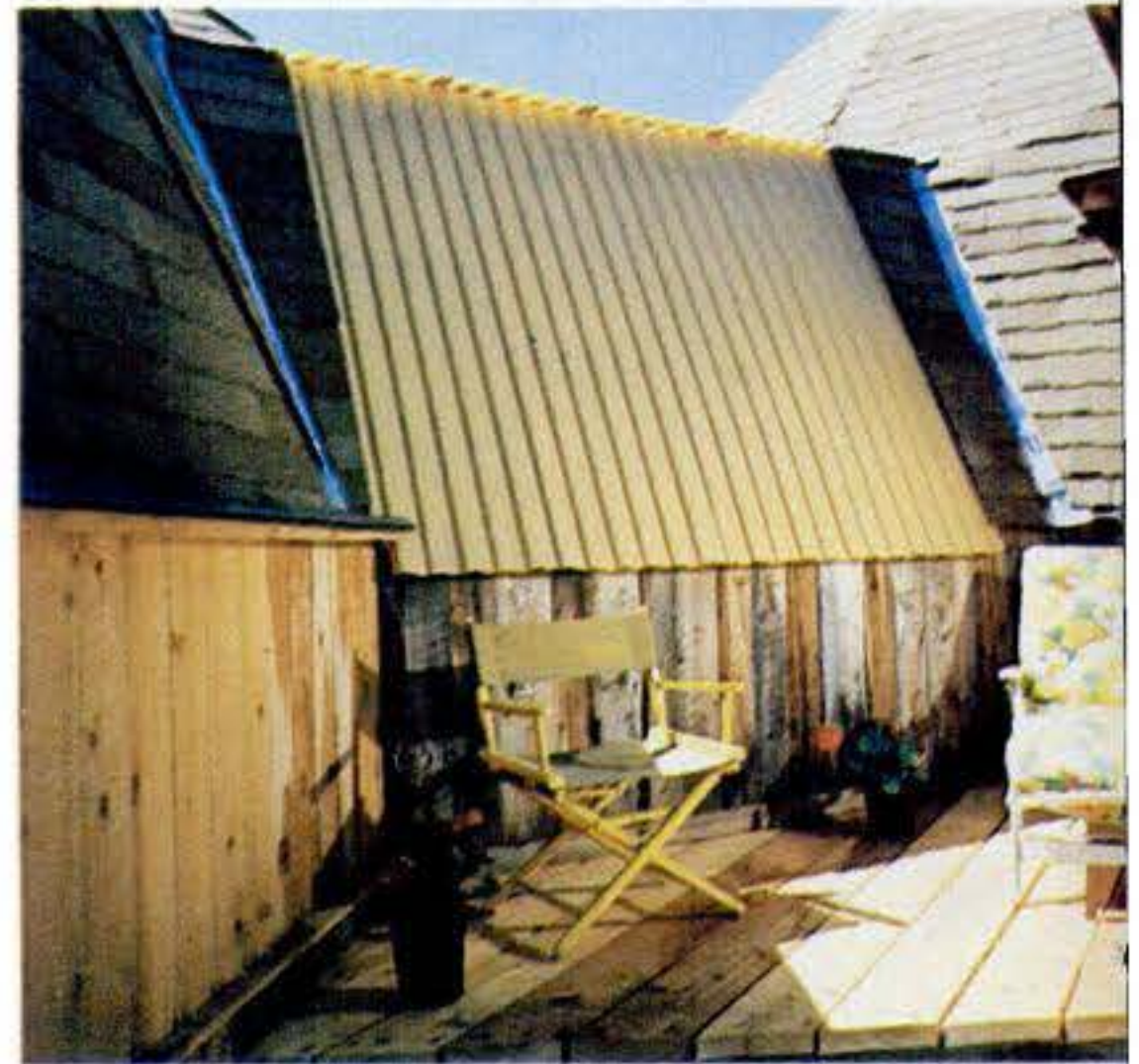

Interiors are shown directly below their mating exterior; area glows with light.



Project won first prize of \$750 in Miscellaneous Structures category, then was also

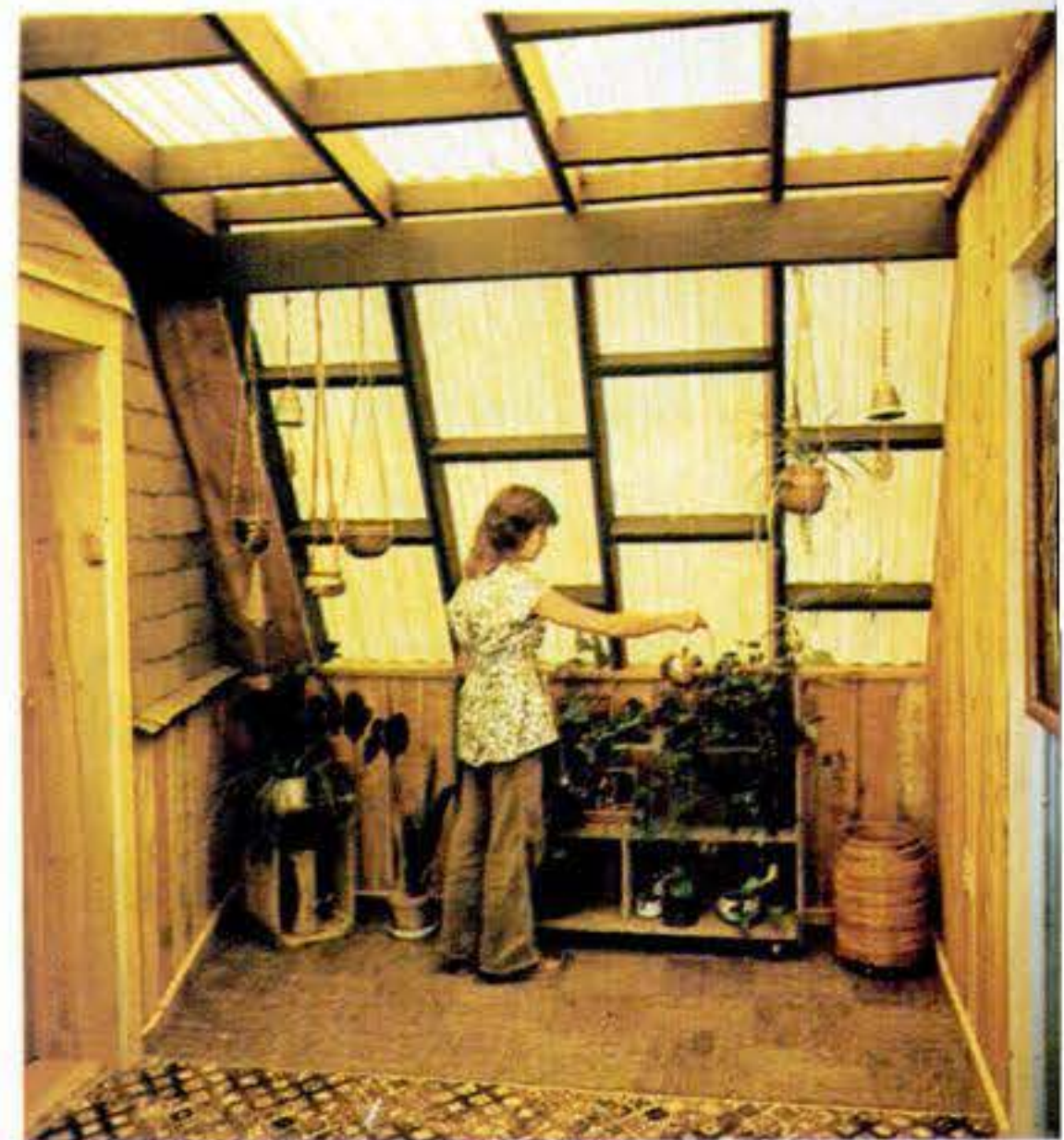

judged best entry overall, for \$1250 more. Two construction details are below.

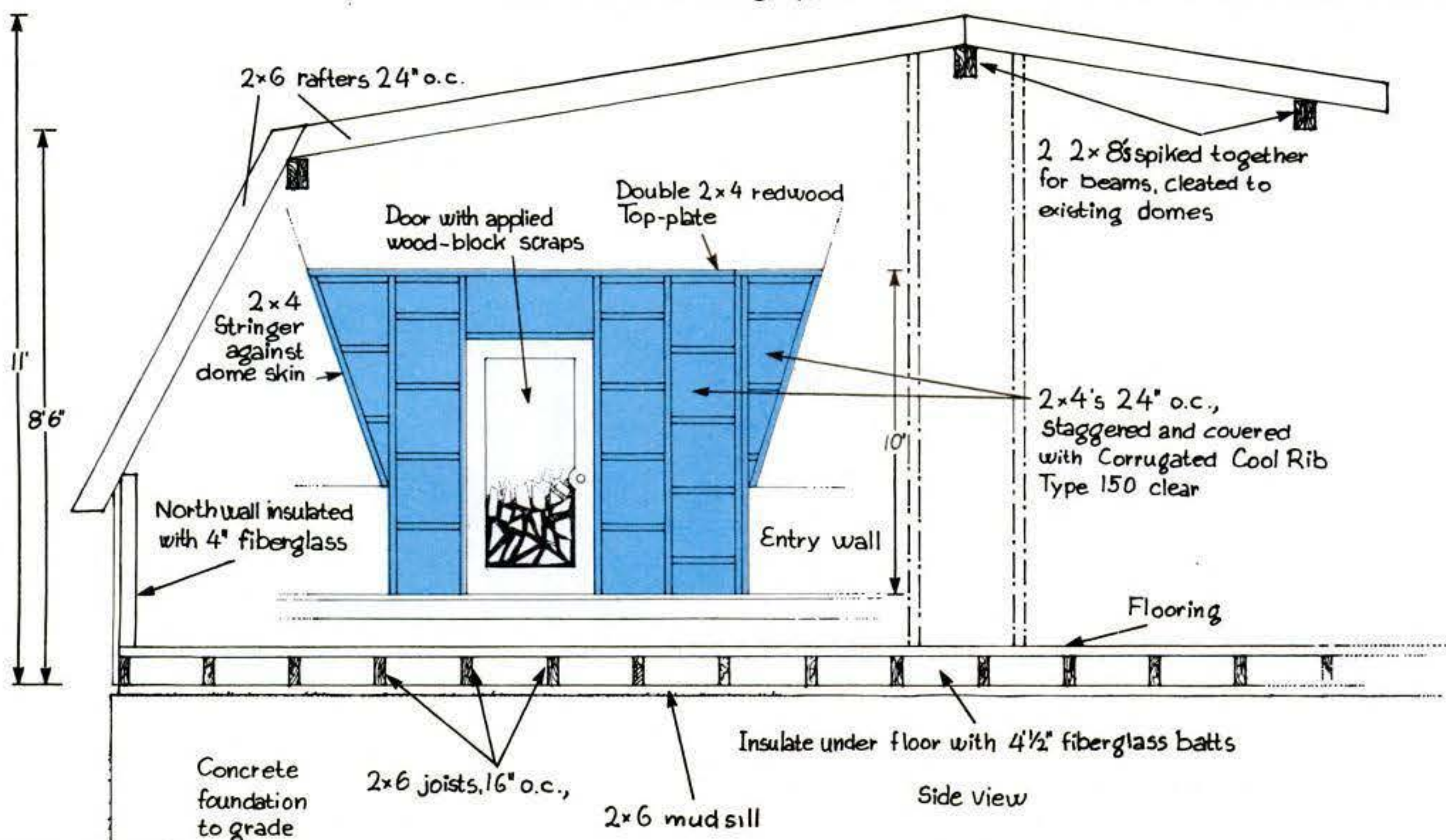

\$750 PRIZE/COVERS

CHARLES K. STEIN, Plano, Texas

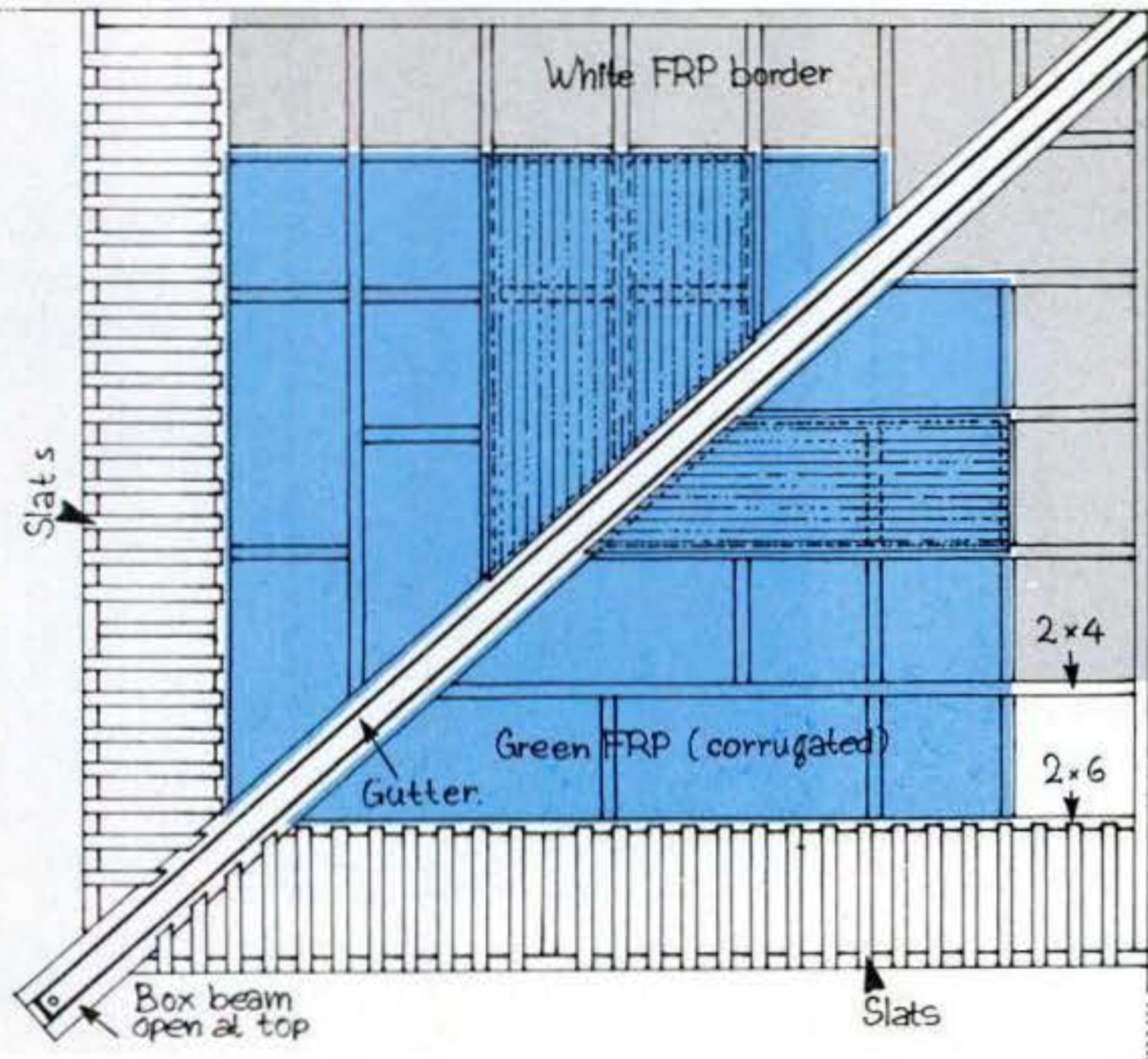

Handsome cover juts across patio that is tucked into L-shaped house. Border of white FRP along eaves provides shelter without cutting light level in shadowed corner. Central support is box beam open at top to channel water so it runs down chain.

Detail of box beam and chain drain

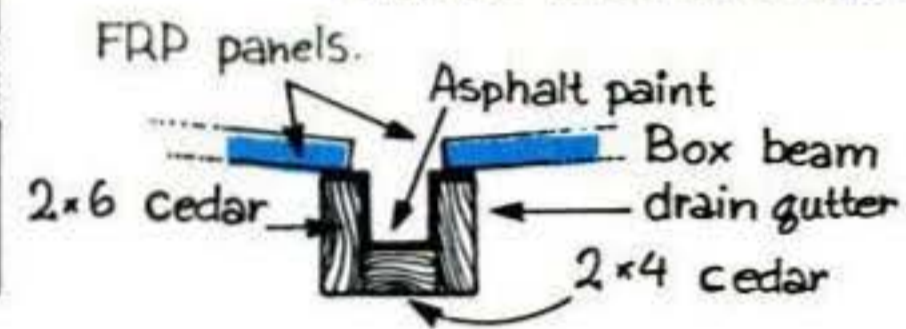

ILLUSTRATIONS BY JAN ZANGERBERG

\$750 PRIZE/GREENHOUSES

HARRY OAKES, Glen Mills, Pa.

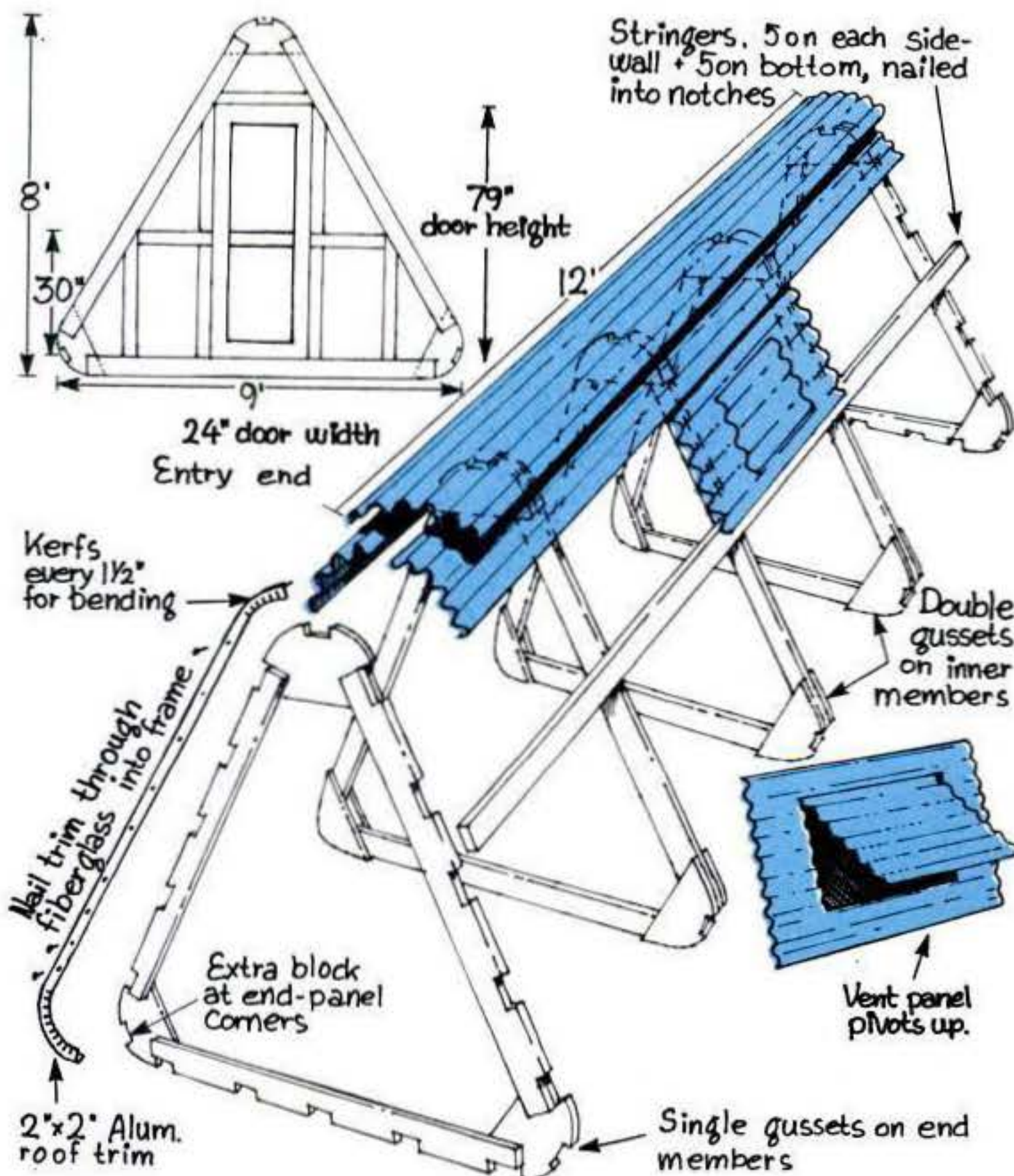

Greenhouse winner Harry Oakes also won a design prize in our recent Plywood Projects contest (see August '79 issue). Filon's plans sheet gives all dimensions for constructing unit, plus all accessories shown in lower photo: bench, floor tray, shelves.

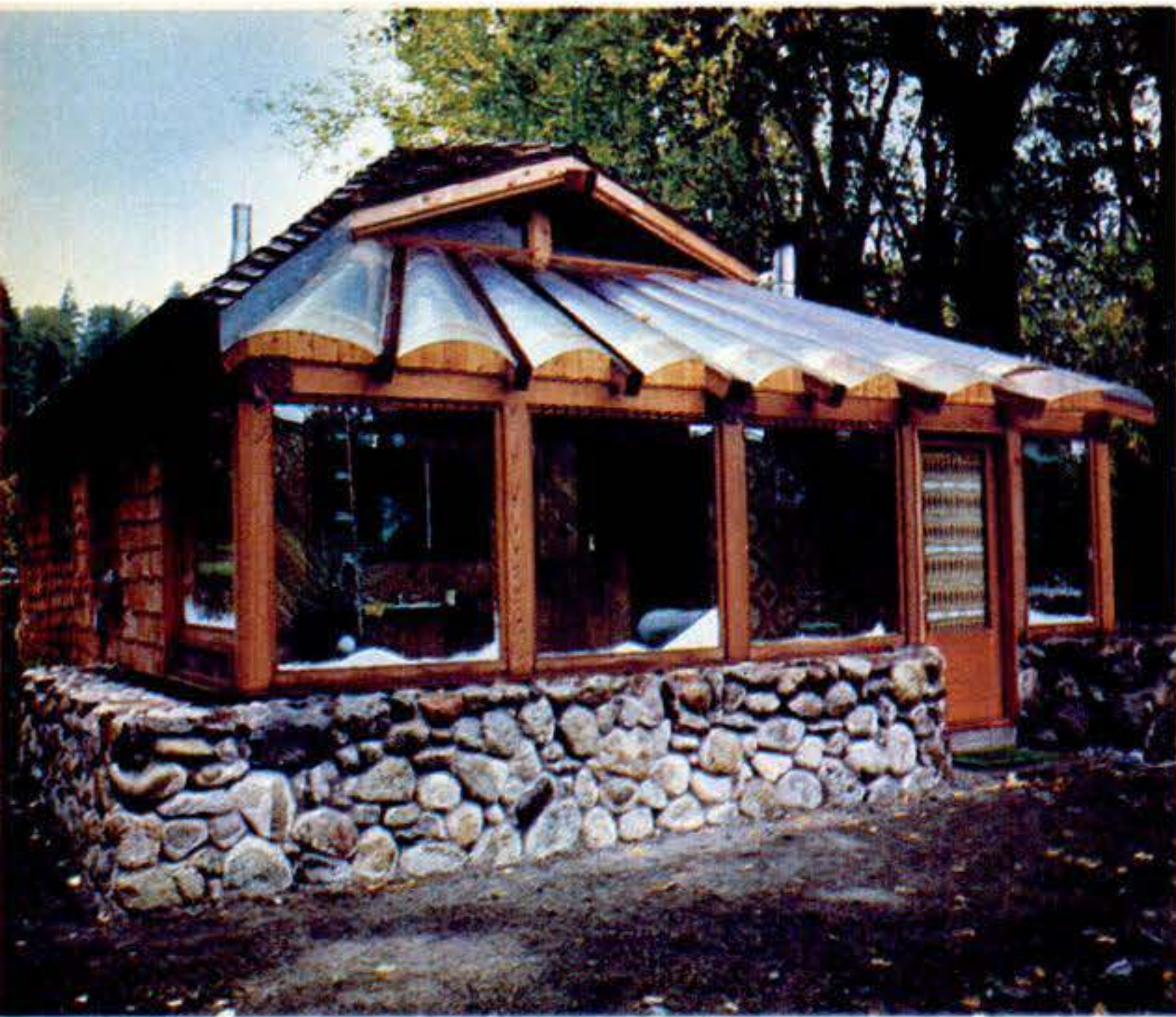

\$750 PRIZE/SOLAR ROOMS

RONALD HENNIG, Mt. Shasta, Calif.

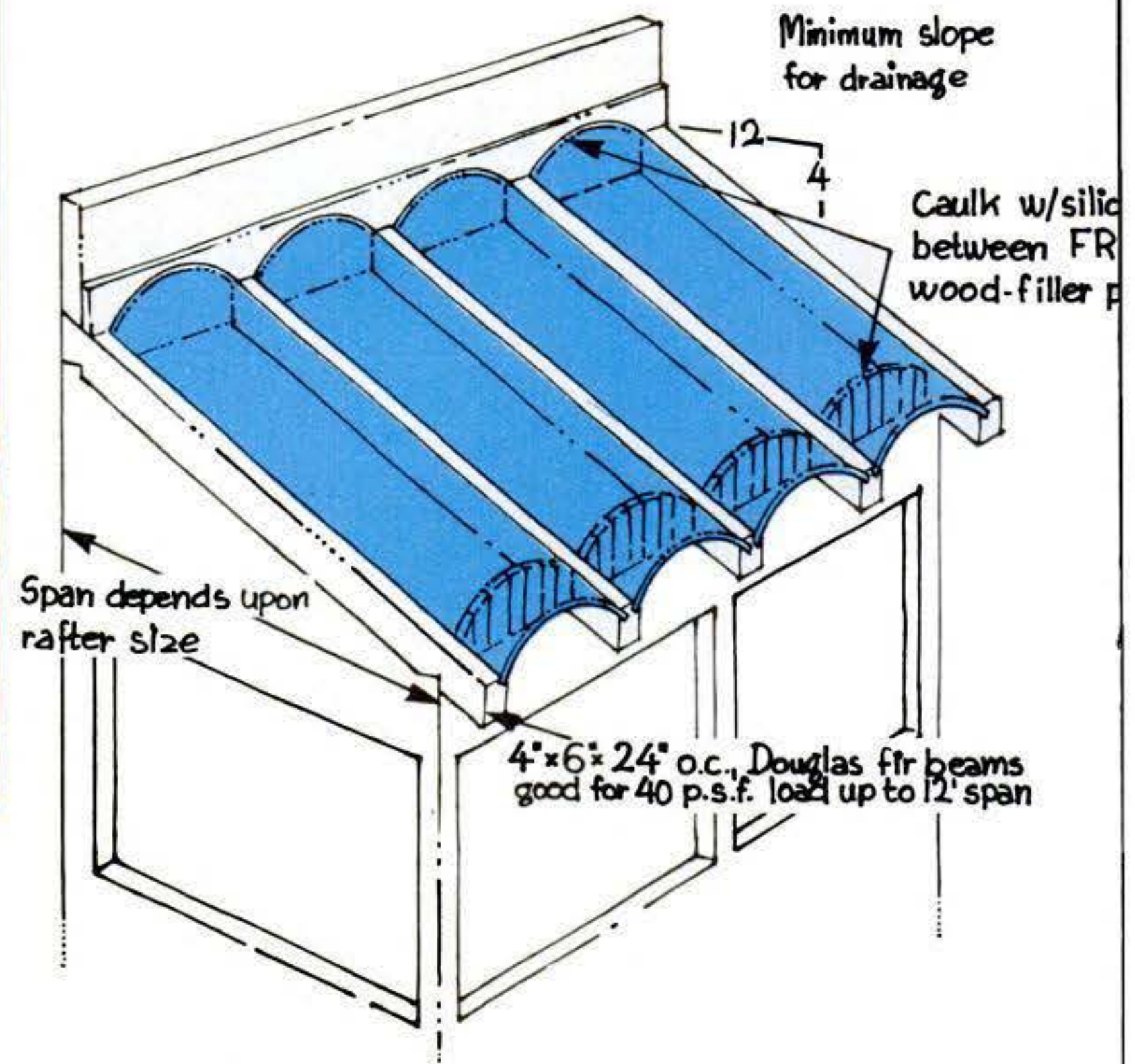

Clever fluted roof for sun porch is giant solar skylight—double glazed, with insulating air space. Tiled interior holds heat well. In summer, canvas screen across roof shades it. Glass walls (Zomeworks' Beadwall) fill with insulating beads at night.

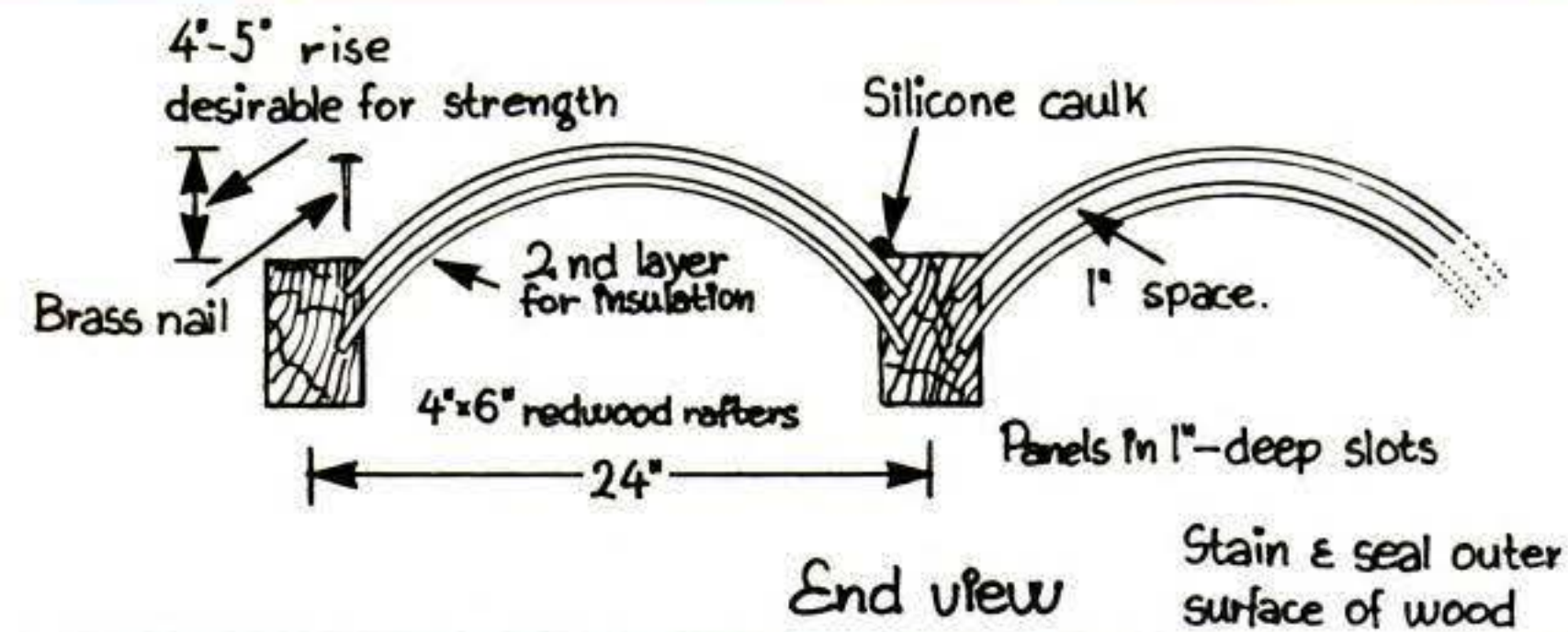

\$750 PRIZE/FRAMED VERTICALS

JOHN C. CASE, Palm Springs, Calif.



This winner wanted to enclose his carport for all-weather use without losing daylight illumination. Giant panel of Filon Type 400 FRP is lightweight enough to ride on standard tilt-up hardware. Simple reinforced frame is 2x2's bordered with 2x4's.

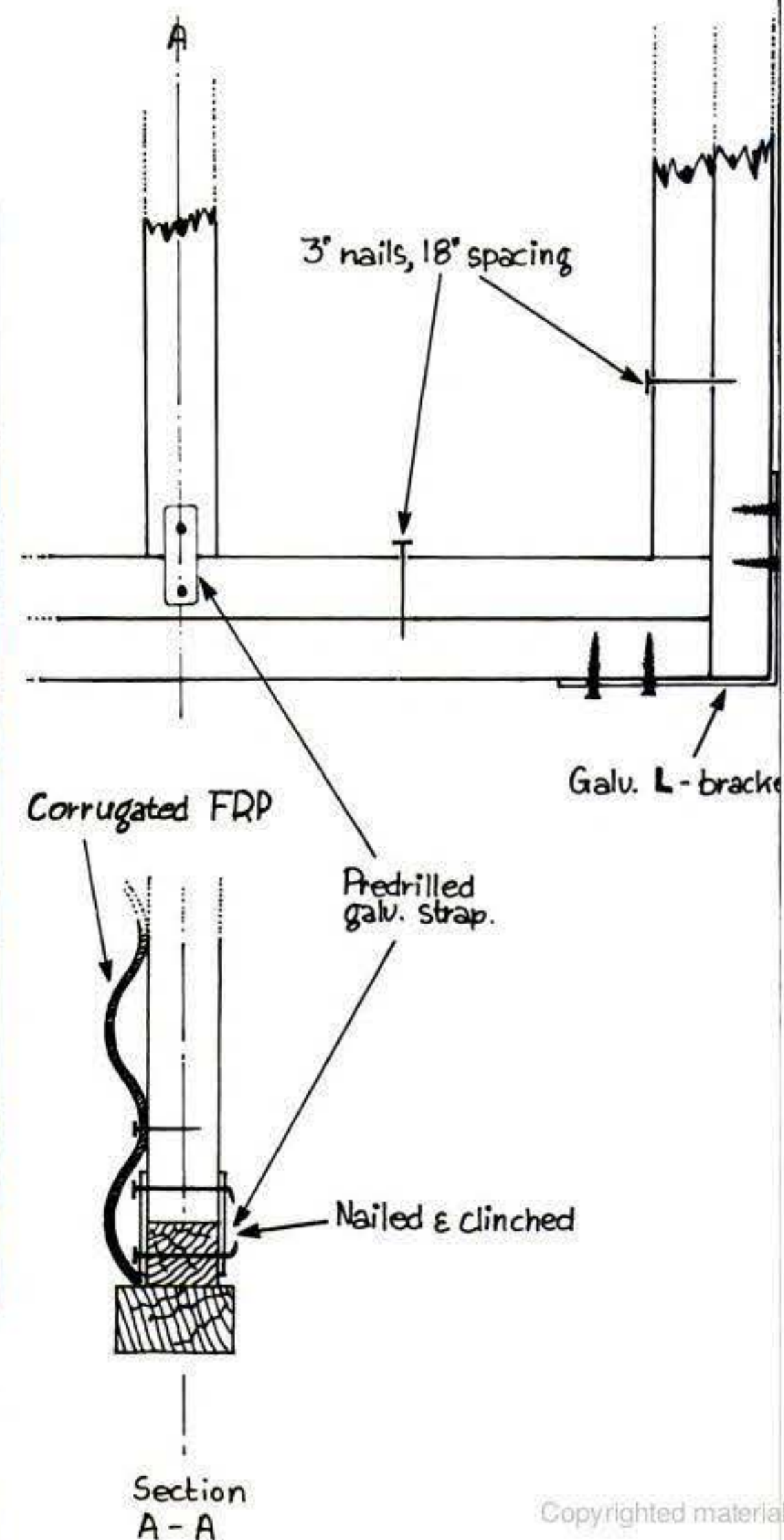

HONORABLE-MENTIONS

MISCELLANEOUS STRUCTURES

TOM HAYS
Austin, Texas

Stair canopy was incorporated into design of this custom house, which has massive entry stair from garage. The greenhouse-type FRP, in continuous strip above treads and landing, bathes stairs with light, day or night.

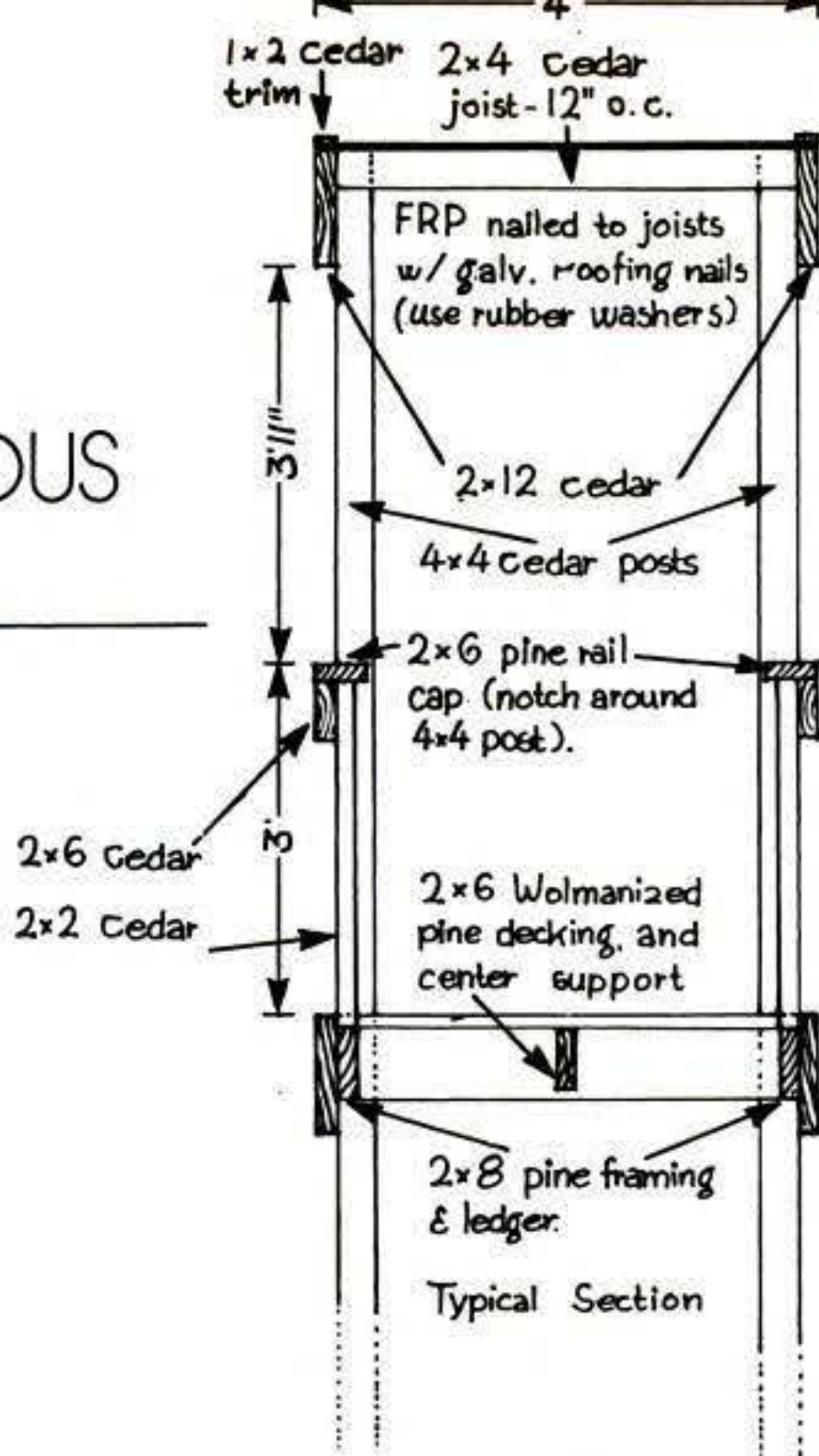

COVERS

W. F. MacDONALD, San Diego, Calif.

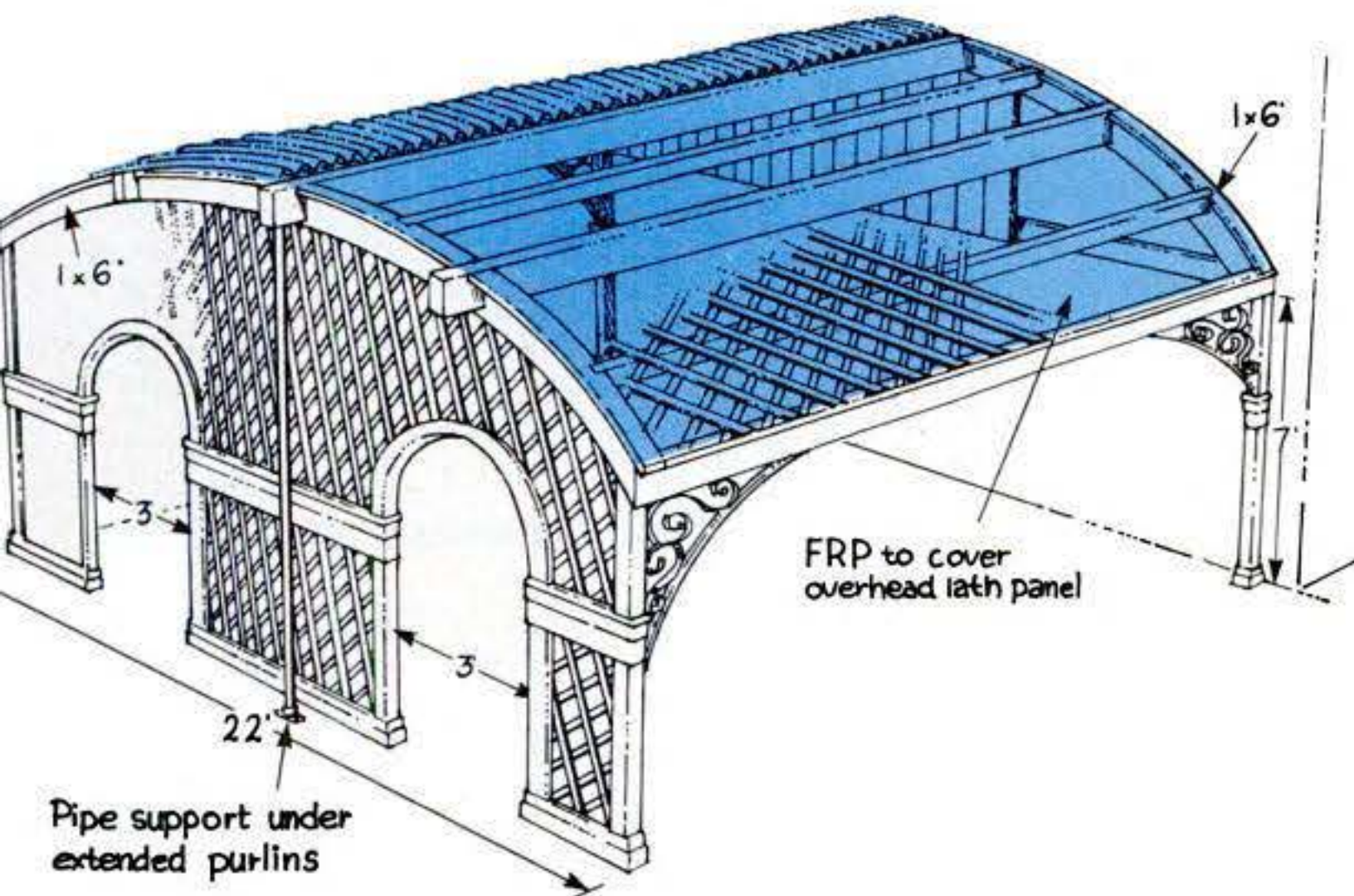

Victorian gazebo frames patio with lattice. Overhead, lath panels are topped with FRP to let light, but not rain, filter through.

tatives, I had to select a cash-prize winner, plus one Honorable Mention entry, in each project category. And from the top five entries we had to choose the best overall project for the Grand Prize (which carried an additional cash award).

Judging most of the categories was far from simple: The level of quality was unusually high. PS readers are using FRP panels in many innovative and tasteful ways around their homes, as this portfolio of the 10 winning projects demonstrates.

Top prize winner Parma Tyson built an entryway to connect two existing geodesic domes that house her art gallery and home. Mrs. Tyson grows hydroponic vegetables during the long Colorado winters; the room also serves as an exhibition annex, with-

Continued

SOLAR ROOMS

G. C. ANDERSON
Denver, Colo.

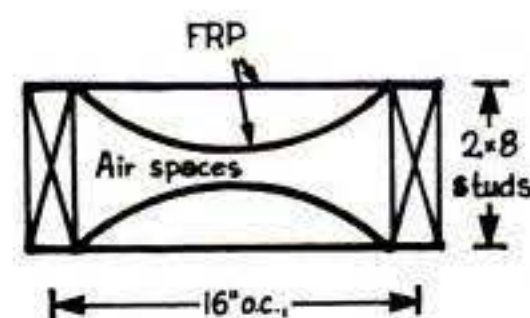

Room addition, for therapy pool, is nearly all FRP: on roof collectors; on flat roof (for translucent ceiling); and in four layers for all windows, sketched above (faces flat, inner FRP bowed, for super thermal glazing).





GREENHOUSES

TERRY L. PATTON, Olympia, Wash.

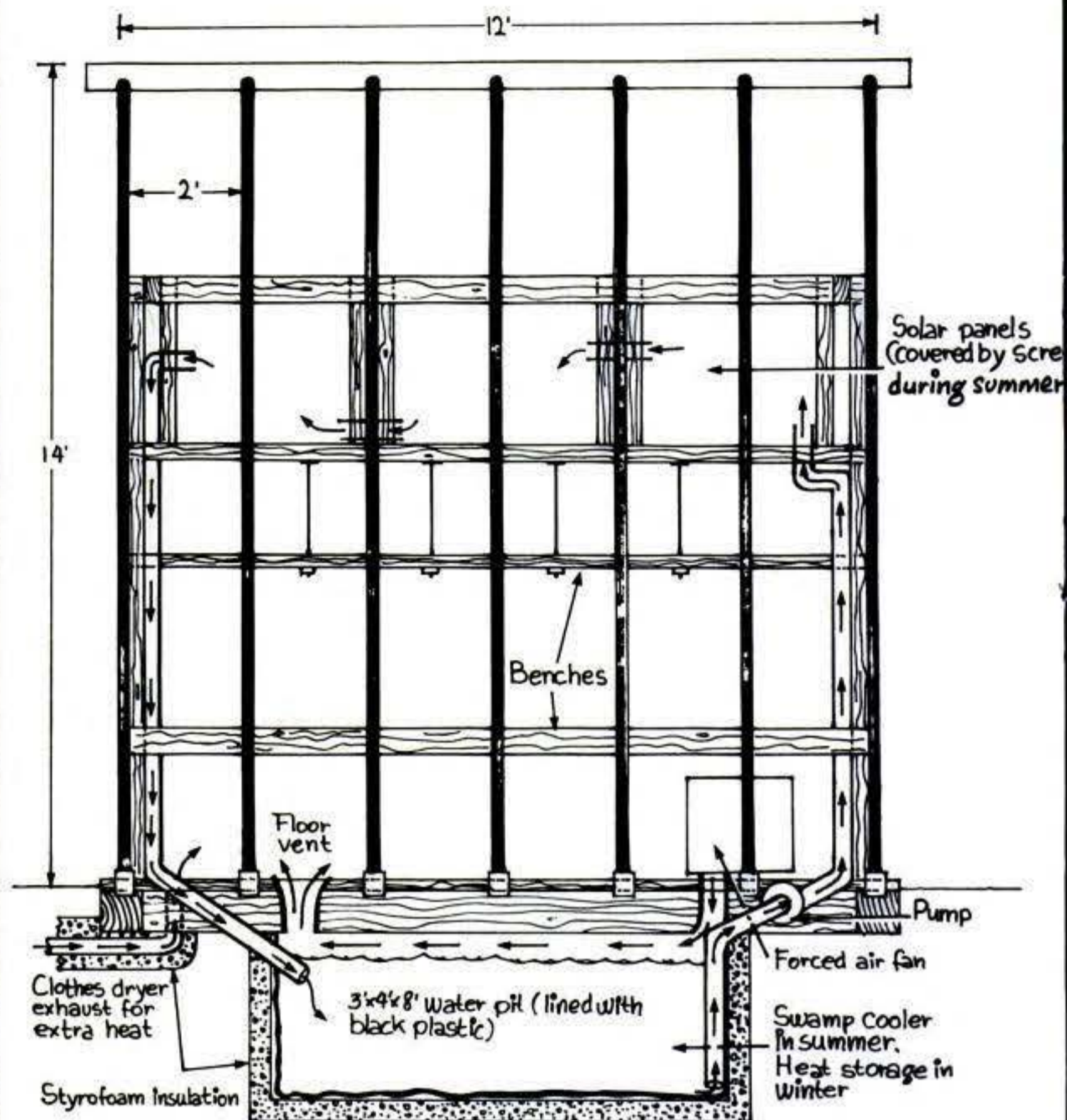

Pagoda shape creates thermal-siphon effect in summer, sheds snow in winter, provides mount for solar collectors. In side view, above, note heating/cooling pool with fan to move air across its surface, and insulated clothes-drier vent from nearby house.

FRAMED VERTICALS

MERLYN M. LIPPERT, Larchwood, Iowa

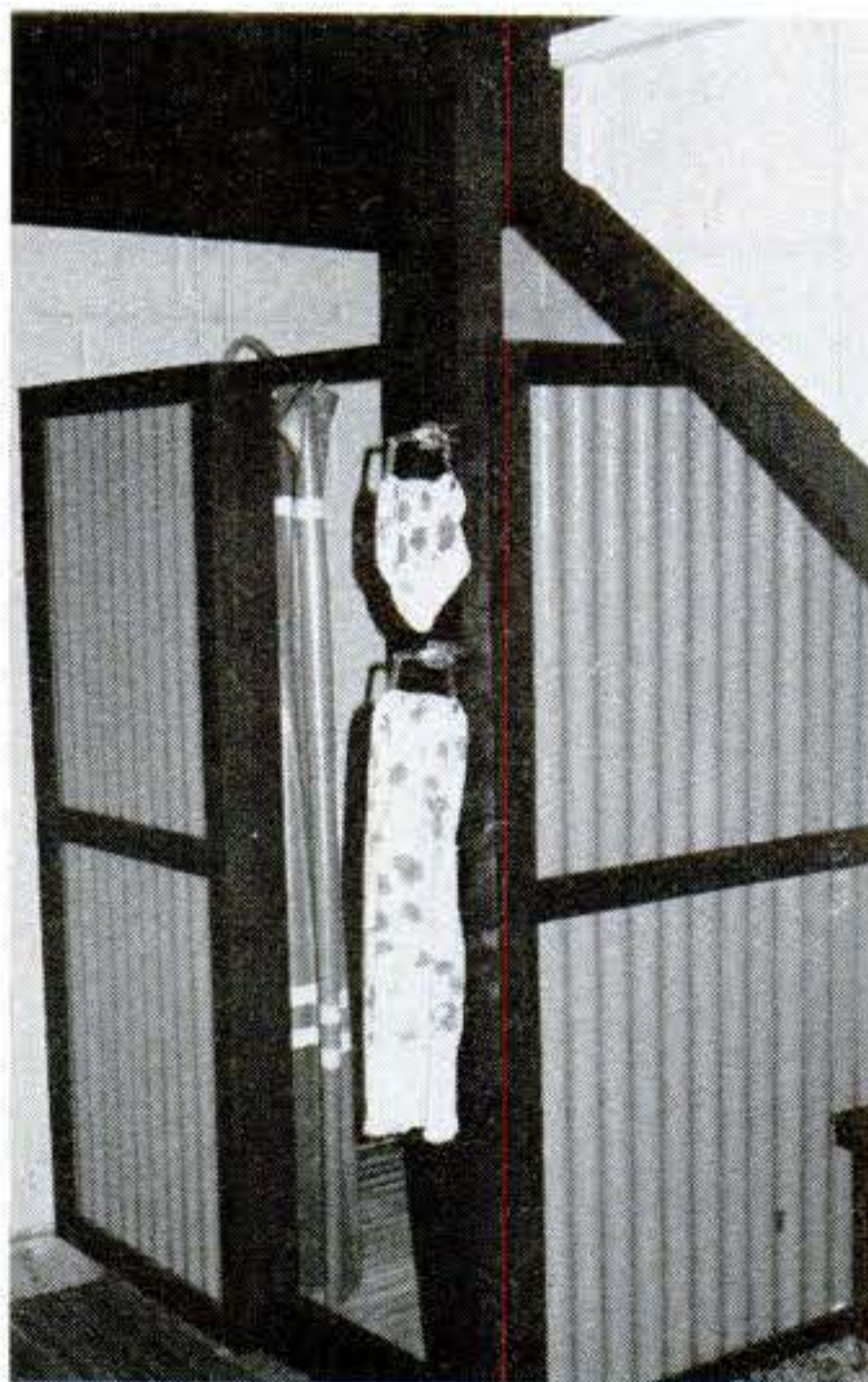

Shower stall, tucked under basement stairs, gives far more elbow room and

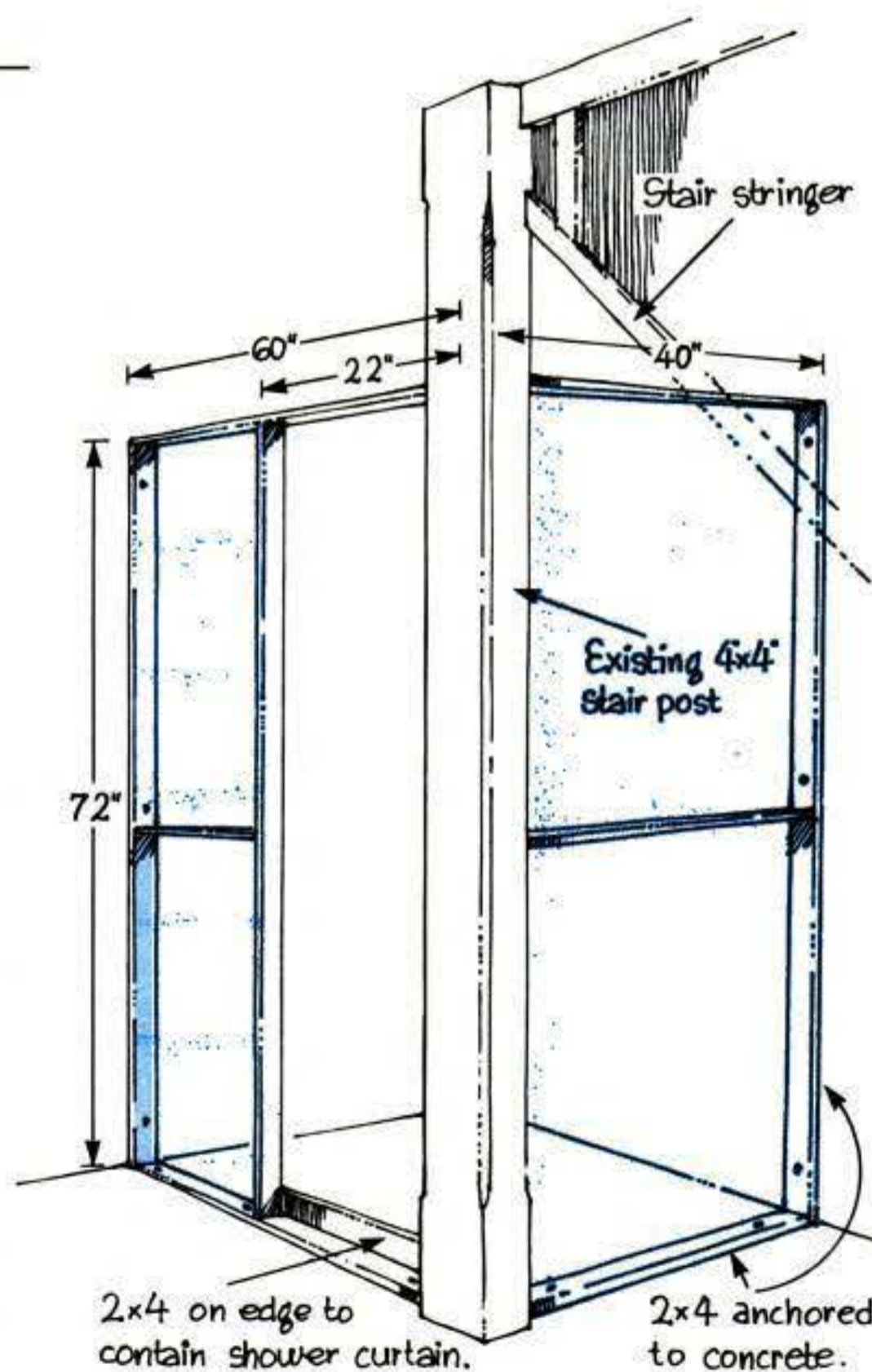

light—at less cost—than small metal unit. Frames of treated lumber tie into post.

out need for any artificial lighting.

One major surprise was the disappointing number of entries in the Solar Collectors slot, for which I had expected a heavy response. Instead, none of the collector entries could be commended, so we came up with two novel solar rooms instead.

As we go to press, Filon is preparing detailed construction drawings of all 10 projects shown here. In some cases, as with the Grand Prize winner, the application is to such a special situation you'd have to adapt the idea to your own needs. In these instances, Filon's plans will show basic construction to help you make that adaptation. Send 50¢ for each plan you want, specifying by the name of the entrant (for example: Harry Oakes Greenhouse).

The contest was such a success we're going to repeat it. You'll find full details—and the official entry coupon—in our May issue. We'll also show a few entries that almost made it into this year's winners circle, to further stimulate your imagination. And this year you'll have until October 1 to get your entry to us—which gives you the long Labor Day weekend to complete your project.—*Al Lees*

At last — EPA tests reveal the truth about those **gas-saving devices**

Miracle mileage boosters?
Or a multimillion-dollar
swindle of U.S. motorists?

By **JIM DUNNE**

Would you buy a device that lets you drive 140 miles farther on a tank of gas? Of course you would.

But do you believe there is such a device? Apparently, a lot of Americans do; they spend millions of dollars each year for devices advertised to do just that—teased by the notion that a miracle mileage booster exists somewhere.

Recently, I visited the Environmental Protection Agency laboratories in Ann Arbor, Mich., where government engineers examine alleged fuel-stretching devices to verify claims of extended mileage. A special testing program was set up, and over 60 devices were run through the lab. "So far, all we've found is zero," reports Peter Hutchins, project manager at the lab. "They're selling miracles, and we've found none."

Gas-saving products fall into several categories—ignition devices, fuel additives, air-bleed systems, vapor air bleeds and water injectors, and air filters. The EPA sampled them all and here's what it found:

Ignition devices

These promise better fuel economy and cleaner emissions. One such device made by the Special Formula Company of Minneapolis consists of centrifugal advance springs that replace stock parts on 1974 GM cars. The EPA test results, however, show that the springs, which provide less tension than stock GM parts, produce no statistically significant improve-



EPA project manager Peter Hutchins cradles some of the gas-saving devices tested by his agency at government labs in Ann Arbor, Mich., shown in background.

ment in fuel economy, while exhaust emissions of NO_x , CO, and HC jumped 33–38 percent.

A second device is the Paser Magnum Electronic Anti-Pollution Engine Economizer. The device fits between the distributor and the spark plugs, and is supposed to transfer energy by a metal connection between the plug wires. EPA's conclusion: "Paser Magnum shows no measurable effect on exhaust emissions and no effect on fuel economy."

Note that by simply advancing or retarding the timing of your engine, fuel economy will change significant-

Continued

How the EPA tests the devices

Here's how the EPA tested the devices described in this article: A test car is run through the EPA city and highway emissions tests without the gas-saving devices. Then a second run-through is made with any adjustments recommended by the manufacturer of the device, but without the device attached (timing or carburetor changes are made at this time). Finally, the car is tested with the gas-saving device. The results—which include emissions levels for hydrocarbons, oxides of nitrogen, and carbon monoxide, as well as fuel economy—are compared. In some cases, the cars are "run in" for hundreds of miles by operators who follow the manufacturers' instructions so that the device has a fair chance to "modify" the engine.

A close-up look at devices tested by the EPA

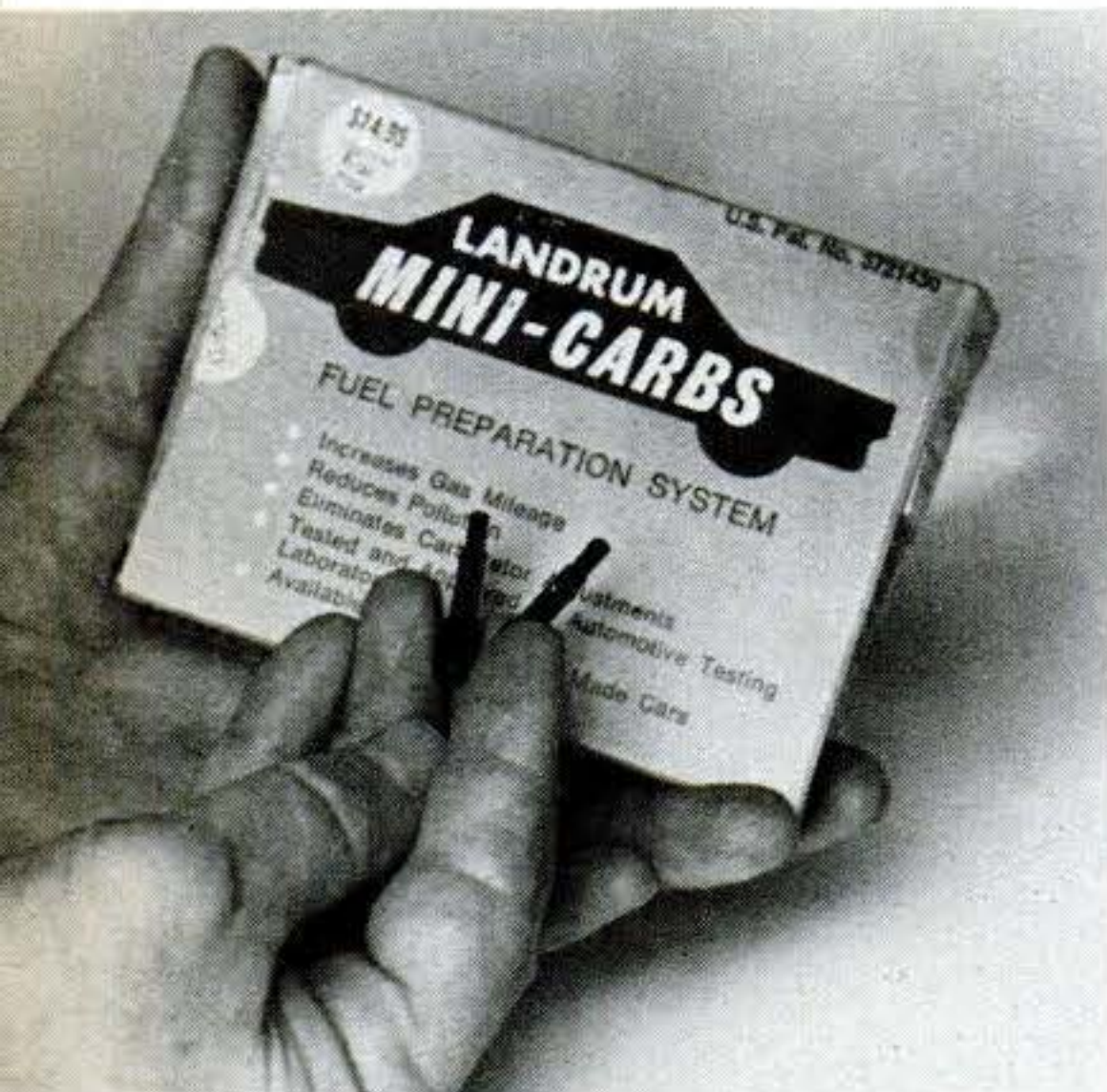

Tiny holes drilled through Mini Carbs are designed to admit additional air to the carburetor. EPA tests found no provable fuel-economy increase with them.

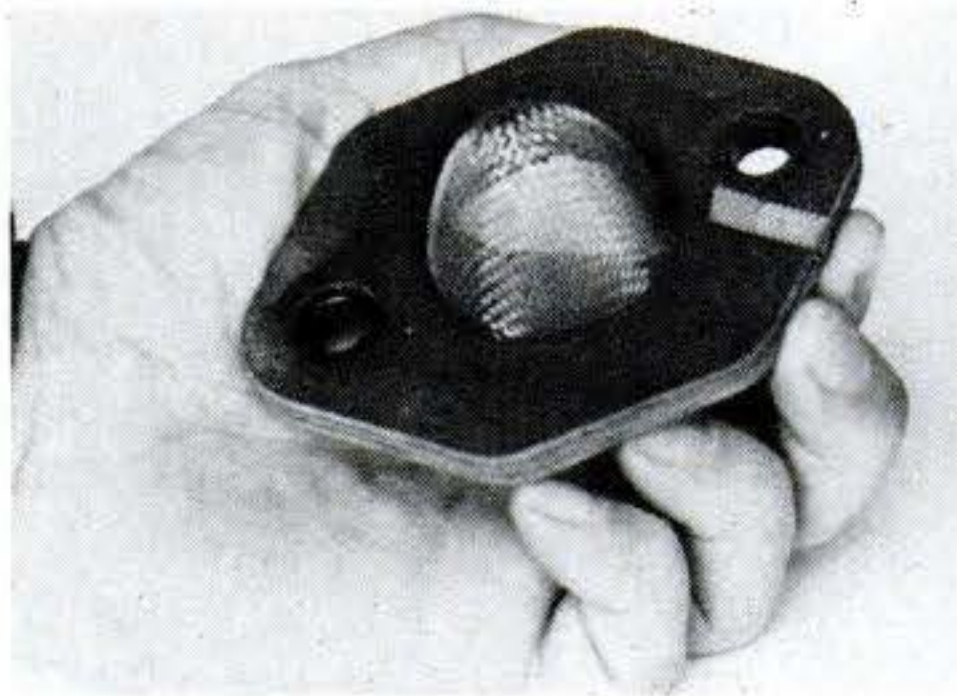

Better atomization and vaporization of air/fuel mix is supposed to occur with the Hydro Catalyst installed between carb and engine. EPA found no gain in mpg.



Paser Magnum is said to direct electrostatic energy from firing spark plug to nonfiring cylinders so it bombards fuel molecules with radiation.



Test engine suffered burned-out valve when the Mark II vapor injector was installed. The air-vapor bleed device offered no fuel-economy improvement.



Up to 50 extra miles per tank of gas is manufacturer's promise for Tephguard. EPA tested it and found no mpg gain or lowering of exhaust emissions.



Finer droplets of air/fuel mixture are said to be produced after installation of Fuel-Xpander. EPA says it performed no better than other tested gas savers.

Synthetic/super-slippery oils:

Included in this group are all the new oils that promise extended life and improvements in fuel economy that result from their "slippery" nature. In one test, of Analube, a synthetic engine lubricant made by Environmental Lubricants Company of New Britain, Conn., some improvement in fuel economy over the base 10W40 petroleum oil was found. It amounted to 3.6 percent, or less than half a mile per gallon of gasoline. The accuracy of this test, however, is not dependable.

It is important to note, though, that the EPA team feels that synthetic oils do offer fuel-economy advantages—probably two percent—and is devising tighter tests to find out exactly what the advantage is. Right now a baseline oil (a 10W40 type) is being formulated to measure against, and

within a year the results should be in. If the preliminary EPA results are proven right, synthetics may eventually replace petroleum oil in new cars. Economy improvements then can benefit both the consumer and the car manufacturers, who must meet tighter mpg standards.

"The oil companies are shooting for a clear one percent improvement, perhaps two percent," says Peter Hutchins, project manager at the EPA labs in Ann Arbor, Mich. "If we can prove two percent, the consumer can probably get three or four percent in the field."

Hutchins points out that the oil companies are realistic when they make their claims so low. After all, there is only so much friction inside an engine that oil can overcome, and it does not approach the 20 percent or more than some miracle-additive marketers claim.

ly in most cases. EPA tests of spark timing shows that highway fuel economy can drop as much as 11 percent when the timing is retarded five percent from its recommended setting. But, by advancing the timing five percent, highway economy can improve by as much as six percent. These tests were conducted by simply comparing different spark settings. No "miracle" devices were added to the car. The phenomenon is important to remember, since many device manufacturers recommend a change in timing as a necessary part of their installation instructions. That means that if an increase in economy does occur, it's probably caused by the timing advance.

Most cars on the road today need a tuneup. Device installation in-

structions often include a tuneup. Manufacturers credit improvements to the device, yet they may come from the new spark plugs or change in timing that go into a tuneup. The EPA claims that an mpg penalty as great as 14 percent can be associated with ignition timing being retarded as much as 10 degrees. The EPA, however, does not encourage advancing the ignition timing beyond the point specified by the manufacturer.

Fuel additives

Buy the fuel additives NRG #1, QEI 400, Rolfite Upgrade, Johnson gasoline additive, or EI-5, and you will go farther on each gallon of gasoline, or clean up your car's emissions, or both. Those are the claims. But EPA tests fail to support them. In no test of these fuel additives did fuel economy improve significantly nor did exhaust emissions show a significant reduction. In some cases emissions levels rose. But even so, fuel economy remained constant—within statistical limits, the EPA says.

Typically, additives are combined with gasoline in quantities of about one ounce per gallon. While some combinations of ingredients are "trade secrets" held closely by the manufacturer, they seem to be mostly petroleum products or detergents, and appear to contain no "miracle" element that would change the laws of combustion physics.

Air-bleed systems

The idea behind air bleeds is that when more air enters the carburetor at a critical location, a better air/gasoline mix occurs. This leads to better burning of the gasoline. Also, the additional jet of air helps homogenize the air/fuel mixture through additional swirl in the fuel stream, and that means more complete ignition.

The Econo-Jets Air Bleed Idle Screws are an example of those tested by the EPA. These were marketed by the Econo Corp. of Detroit, though they may be available under other names in other parts of the country.

Econo-Jets are idle mixture screws that replace the factory-built screws in the carburetor. They are drilled so that a tiny hole allows additional air to pass directly into the carburetor throat through the idle fuel port. The vacuum of the carburetor passage furnishes the pull that's needed to draw outside air through the screw.

After testing Econo-Jets, the EPA team concluded that there is "neither a general increase in fuel economy nor a decrease in emissions associated with the replacement of standard mixture screws with Econo-Jets."

Other air-bleed devices tested by



EPA's Peter Hutchins (rear) watches as technician runs car fitted with gas-saving device through standard EPA fuel-economy and emissions cycle on dynamometer.

Quick installation is one lure of gas-saving devices. Ball-Matic fits easily into carburetor feed tube, but doesn't contribute to fuel economy, EPA says.

the EPA include the Mini Turbo-charger Air Bleed, a Ball-Matic device, and the Landrum Mini-Carbs. EPA conclusions: No significant improvement in fuel economy and emissions levels.

Vapor air bleeds, water injection

Here you find some fuel-economy contribution, but the price is higher than the saving. Among the air-vapor injectors the EPA tested is the Mark II Vapor Injector, marketed by APO of America, Inc., Dallas. This system uses an injector mounted in

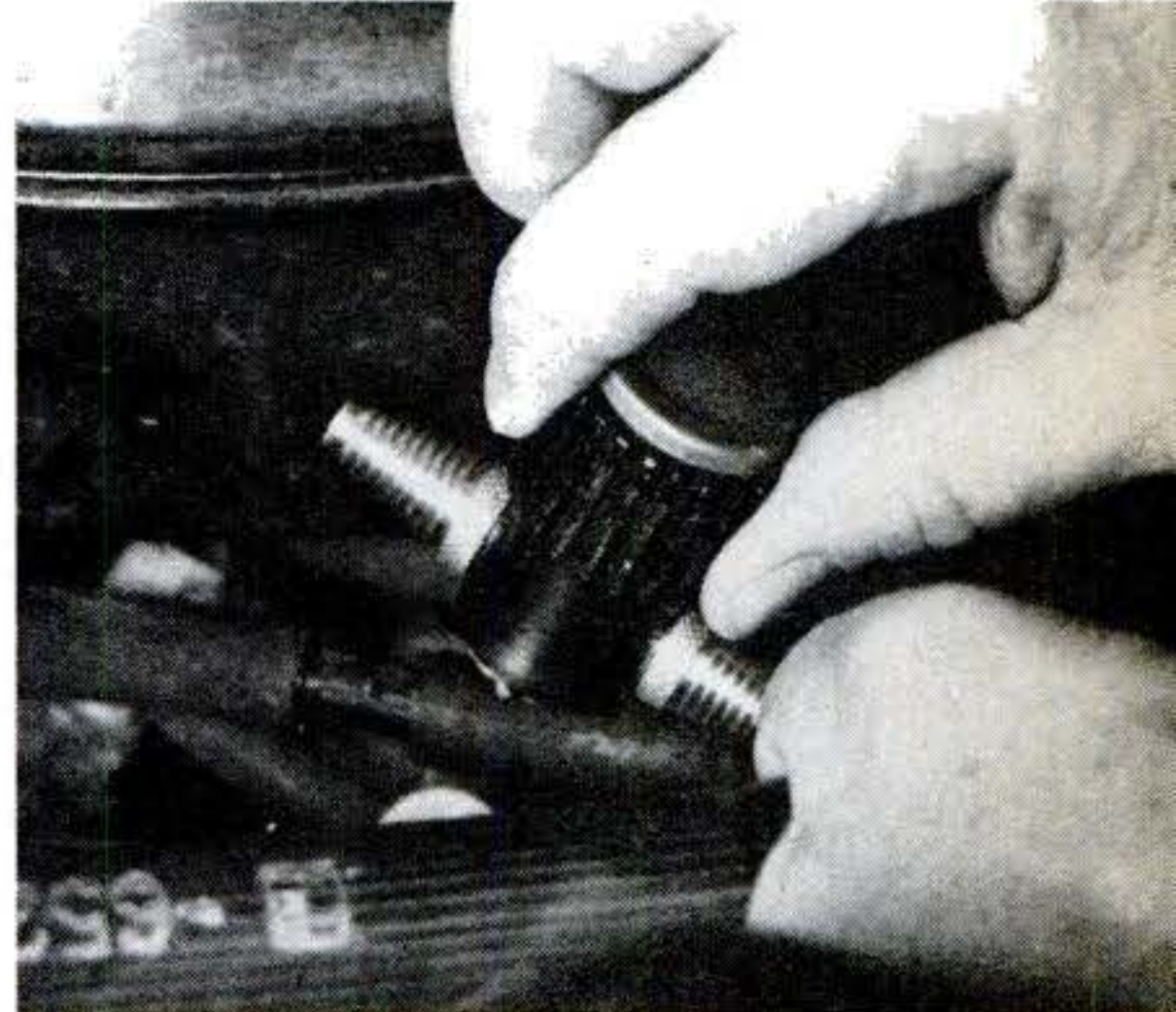

the carburetor-throat body to add moisture to the air/fuel mixture. The vapor material is drawn from a mixture of two-thirds water and one-third Mark II Econo Mix fluid that is stored

[\[Continued on page 182\]](#)

Gas-saving devices tested by the EPA

Air bleeds—devices that bleed air into the air/fuel mixture: ADAKS Vacuum Breaker; Air Jet; Aquablast Wyman Valve; Ball-Matic; Berg; Econo-Jet Idle Screws; Econo Needle; Landrum Mini-Carb; Landrum Retrofit; Mini Turbo-charger; Monocar HC Control; Peterman; Pollution Master; Turbo-Dyne GR Valve.

Fuel additives—materials that are added to the gas tank: EI-5; Johnson; NGR #1; QEI 400; Rolfite Upgrade; Sta-Power; Stargas; Technol G; Val-Do Combustion Cleaner and Power Lube; Verb 10.

Carburetor-intake manifold devices—devices that are claimed to improve the atomization and vaporization of the air/fuel mixture: Environmental Fuel Saver; Hydro-Catalyst Precombustion Catalyst System.

Lubricants—usually materials that

are poured into the crankcase: Analube; Tephguard.

Ignition controls—devices that are attached to the ignition system: BIAP; Magna Flash; Paser Magnum; Special Formula Advance Springs.

EGR—add-on EGR system: Lee Exhaust and Fuel Gasification EGR.

Vapor air bleeds—similar to air bleeds but air is bubbled through a water/antifreeze solution: Econo-Mist; Frantz; Mark II; SCATPAC; Turbo.

Intake-system devices—modifications to intake system: Electro-Dyn Superchoke; Filtron Urethane Foam Air Filter; Lamkin Fuel Metering Device; Smith Power and Deceleration Governor.

Fuel-pressure regulator—device for controlling pressure of the fuel delivered to carburetor: Malpassi Filter King.

Shelter fence

and kindling bin
keep firewood dry

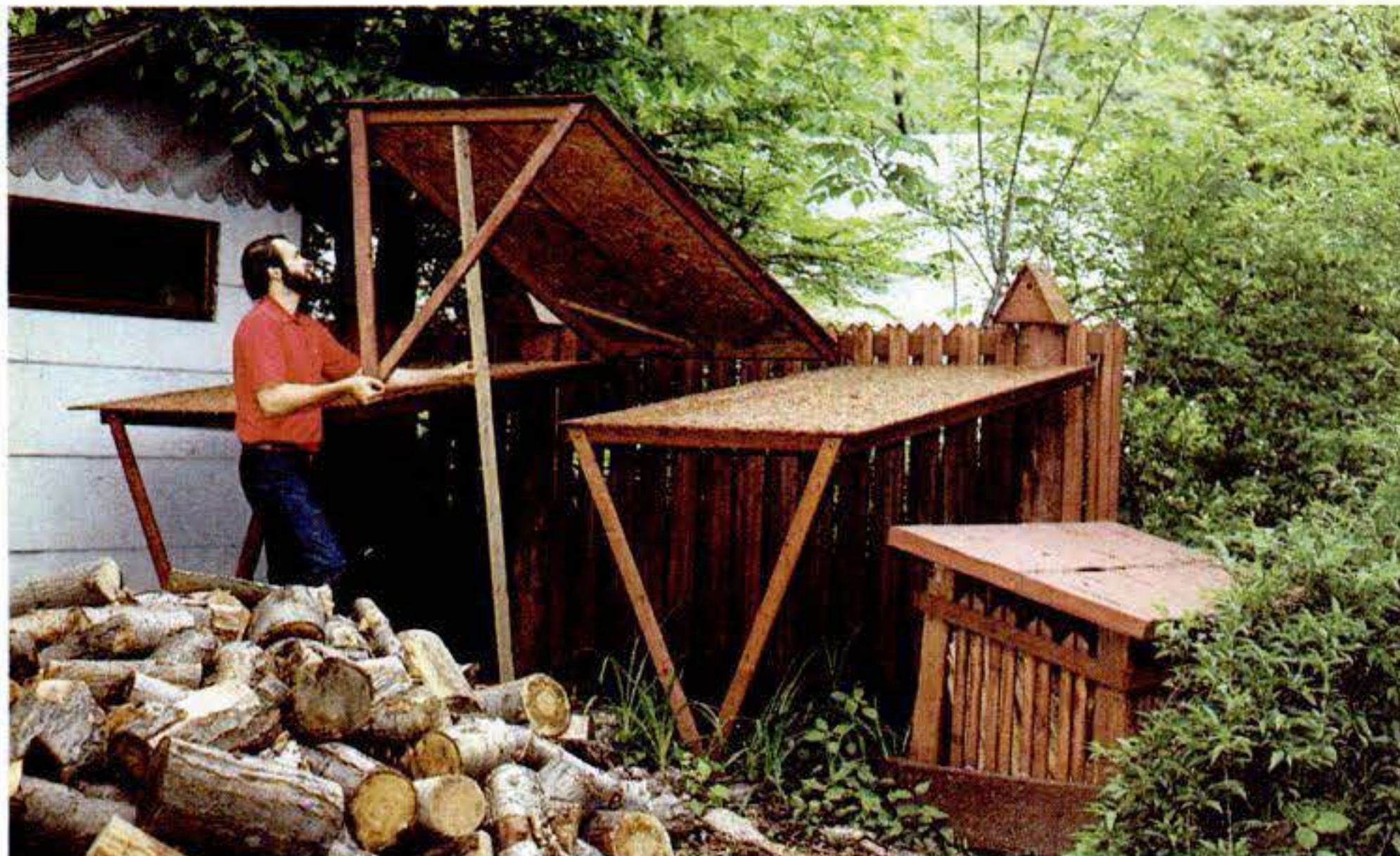

The 12-foot unit shown will cover three cords of wood

By NEIL SODERSTROM

A proper place for wood and kindling adds to the pleasure of putting by wood. With this shelter fence and kindling bin, you can forget the hassles that accompany makeshift wood covers. Here are some of the features:

- The 12-foot shelter fence shown here will protect nearly three cords of wood—or shelter both wood and yard implements. You can increase capacity by extending the fence as your property permits.

- The fence screens off your work area, giving privacy while sparing neighbors the temporary clutter of your cutting and splitting.

- The kindling bin will hold two cu-

For access under the shelter fence or for stacking wood, you raise and prop middle panel before side panels (above). When

the shelter is full of wood, simply reach through the framing to fetch it (below). Kindling bin is smaller structure at right.



bic yards of bark or other kindling while it seasons.

By recycling some scrap timber and hardware, I was able to keep costs for the two shelters well under \$100. I made my own fence posts by halving the trunk of a cedar tree that a neighbor was removing. Cedar splits easily down the center with a sledge and a few wedges. Cedar, white oak, and locust make long-lasting posts. If durable post wood isn't available, you can purchase posts specially impregnated for subsoil use at a lumberyard.

Construction

The fence posts should be sunk a minimum of 2½ feet—at least below the frost line. A horizontal notch, or dado, for 2×4 rails should be made with a bow saw and hatchet after the posts are erected. If you make notches on both posts before setting, it will probably mean extra digging, tamping, and hauling posts in and out repeatedly to even up the notches. Since the wood will weather rapidly, it's best to use a 2×4 rail that has been treated for outdoor use. The posts should also have an appropriate preservative applied from the bottom to about a foot above ground level.

Fencing is inexpensive 1×2 pine mitered on one end and nailed up back-to-back to look like a picket fence. Each pair of pickets is nailed on alternate sides of the rails. By staggering the vertical pickets, you achieve an ideal compromise of screening and circulation. And the more air circulated within the woodpile, the faster the wood will dry. Be sure to use galvanized nails for the pickets—5d or 6d should be long enough.

The covering panels are exterior-grade ¼-inch Aspenite (flakeboard) on frames of 1×3 pine. The middle panel overlaps the side panels to keep rain out. One four-by-eight-ft. panel will shelter about a cord of wood. I trimmed mine to seven-foot lengths, anticipating heavy snow loads on the



A sawing jig or miter box allows uniform cutting of four or five stacked slats. Here, eight-ft. furring is cut to six-ft. lengths, leaving two-footers for slatting of bin.

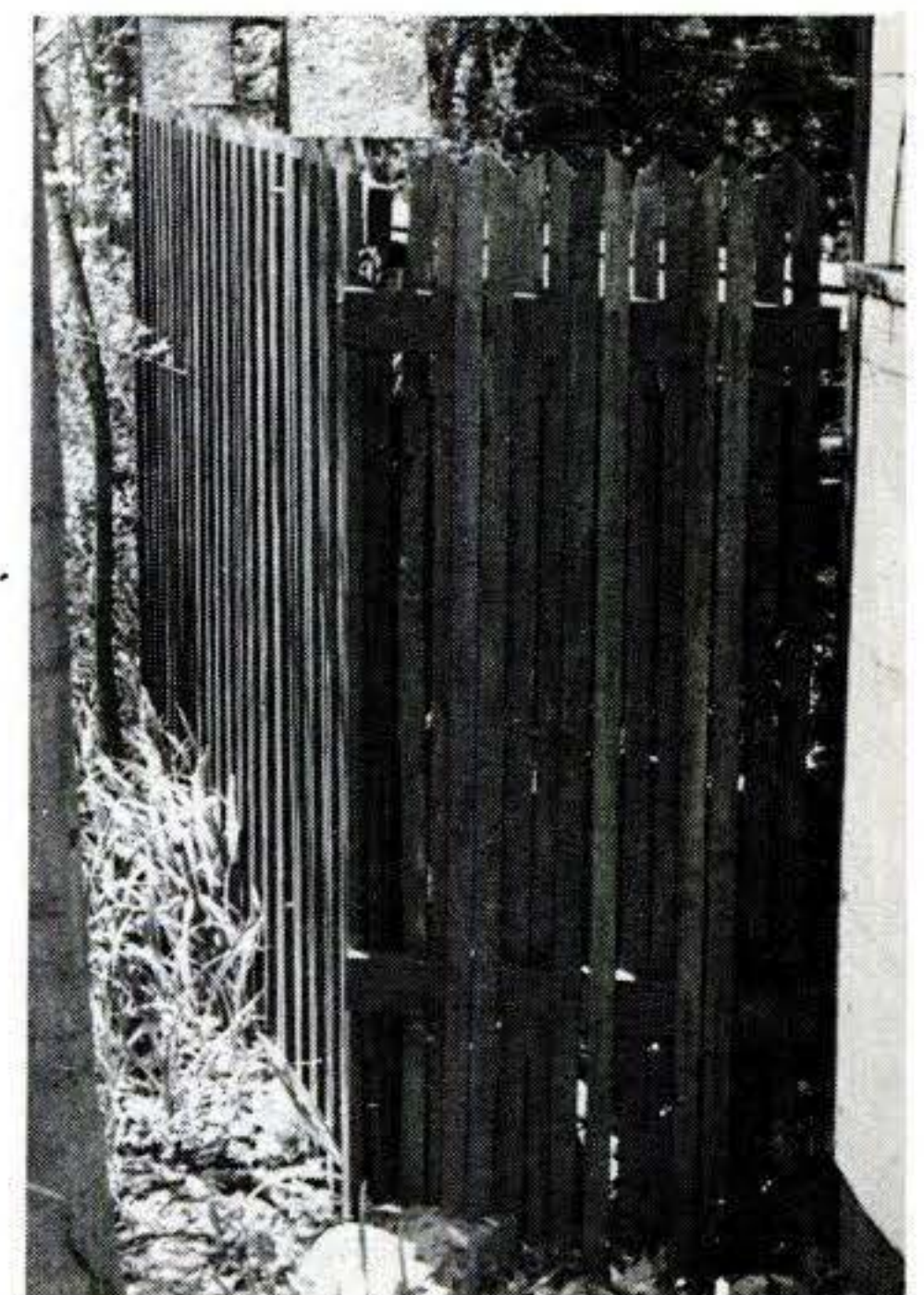

Use a level to keep slats true (top). Staggered slats provide good air circulation. Finished fence has birdhouses atop posts (above); they handily shed snow and rain.

light-duty pine framing. The V-frame supporting the panels is 1×3 pine bolted to the frame and joined to each other with a triangular piece of plywood.

Shelter hinges consist of large eye screws in the frame of the panels. They rotate on a steel rod supported by eye bolts through the rail. I wrapped baling wire around the frame member holding the eye screw to prevent end-splitting. Hinges for the kindling box are just a bolt through both the roof frame and the support posts (see illustration).

The kindling bin was made from scraps of odd sizes, scrap timber, and 1×2 furring left over from the fence construction. Vertical slats nailed inside the framing withstand the outward pressure of the kindling. The bottom of the bin is left open but is covered with masonry rubble to raise the kindling pieces off the soil. The lid is a flakeboard panel painted with a good weatherproof enamel. PS

Shelter-fence hinges

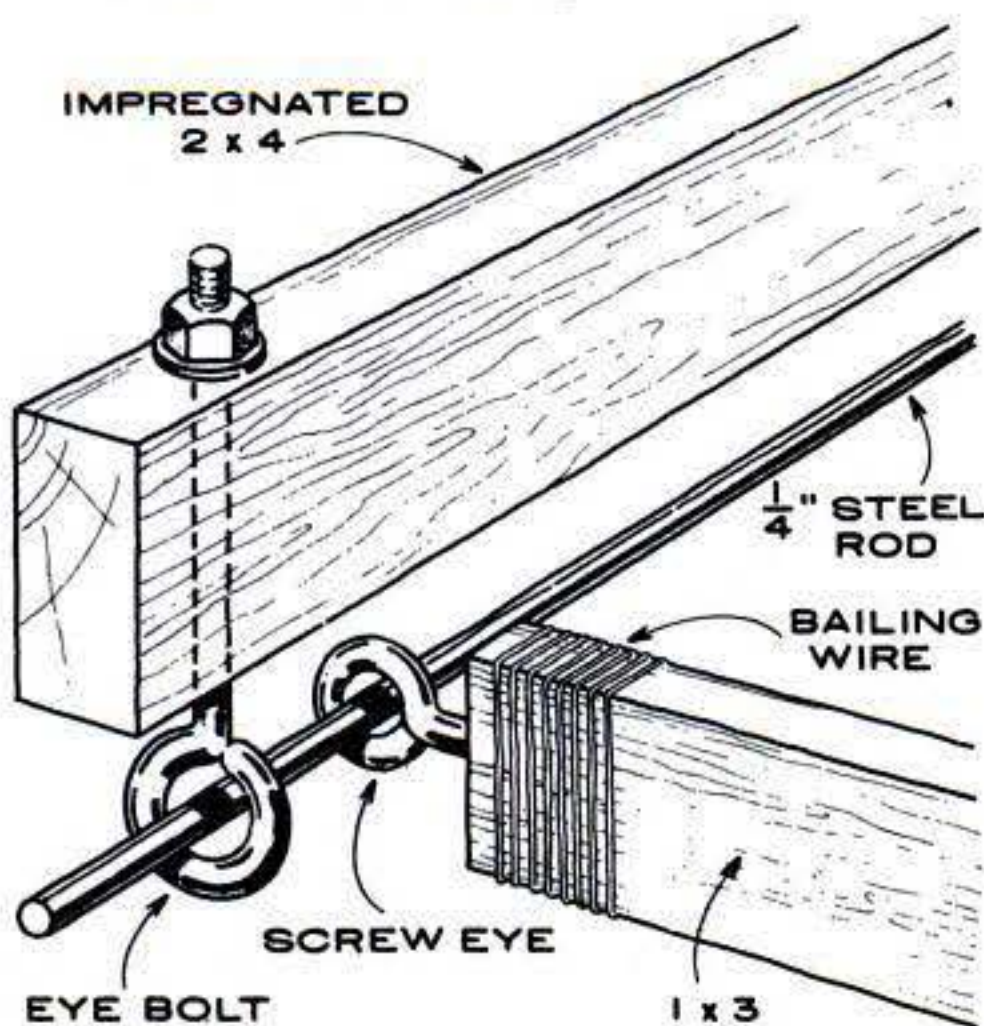

Framing of shelter roof

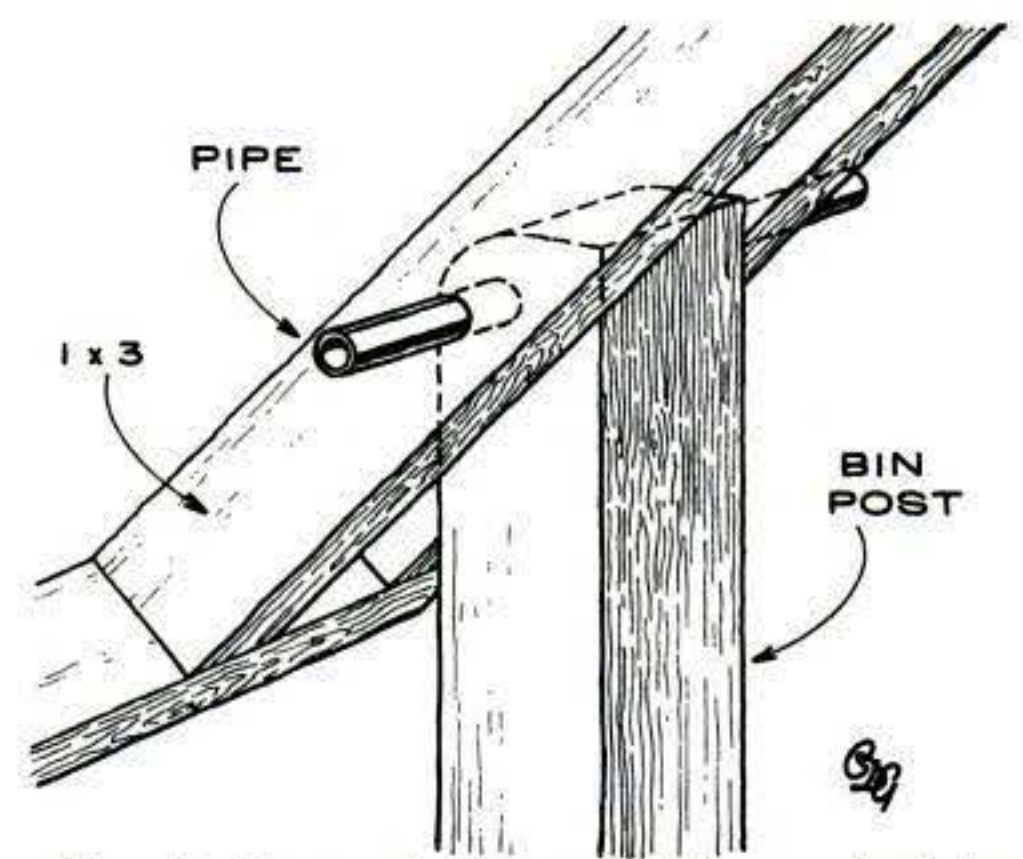
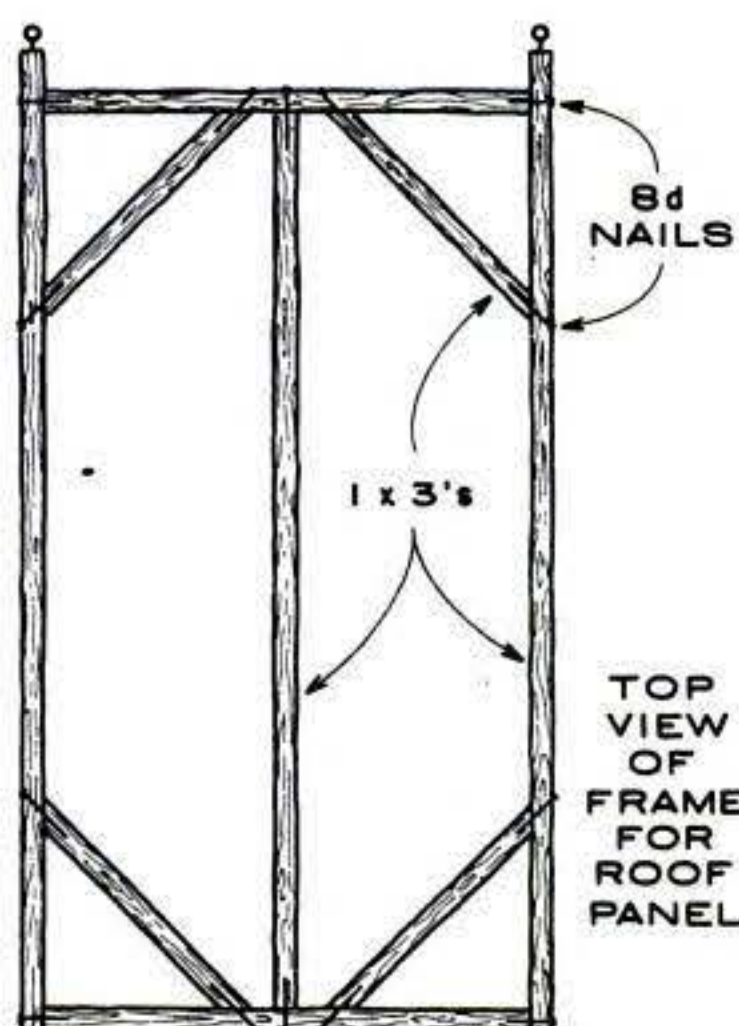

Simple hinge pin supports the roof of the kindling bin. Pins can be salvaged lengths of either steel or copper pipe.

Install a backyard antenna to tune in satellite TV

With dozens of channels out there—an incredibly rich TV fare—why limit yourself to local stuff?

By **ROBERT B. COOPER JR.**

If your TV set picks up just one channel, or even five, the idea that you're only a dish antenna away from up to 60 additional TV channels may be more than you can bear. These channels are used by U.S. and Canadian communications satellites [PS, Mar.

Raising the dish, three satellite-TV fans muscle a three-meter (10 ft.) parabolic antenna into position. Antennas can be bought assembled or in kit form. Knowledgeable amateurs can set up the assembled antenna in about an hour.

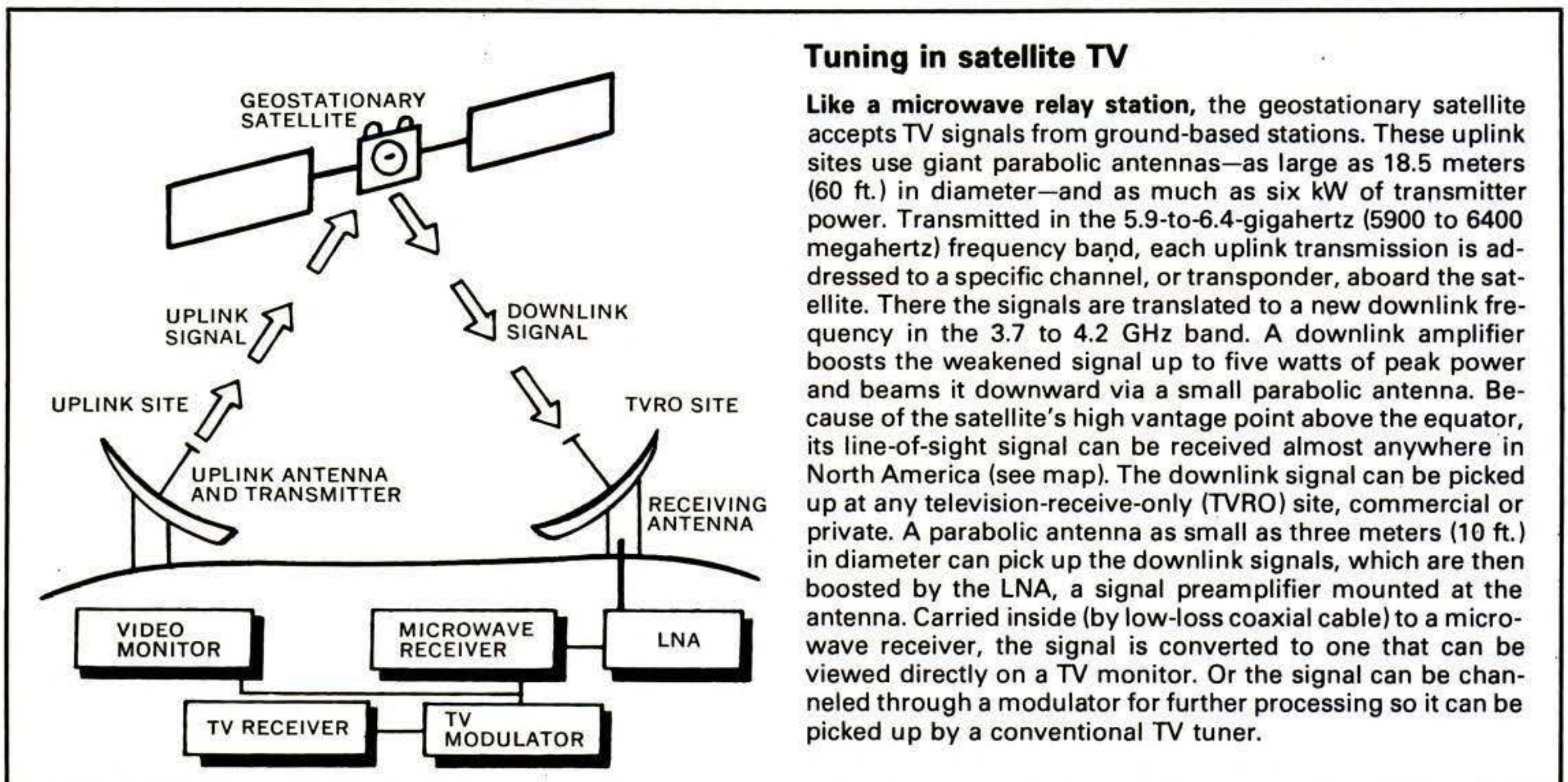
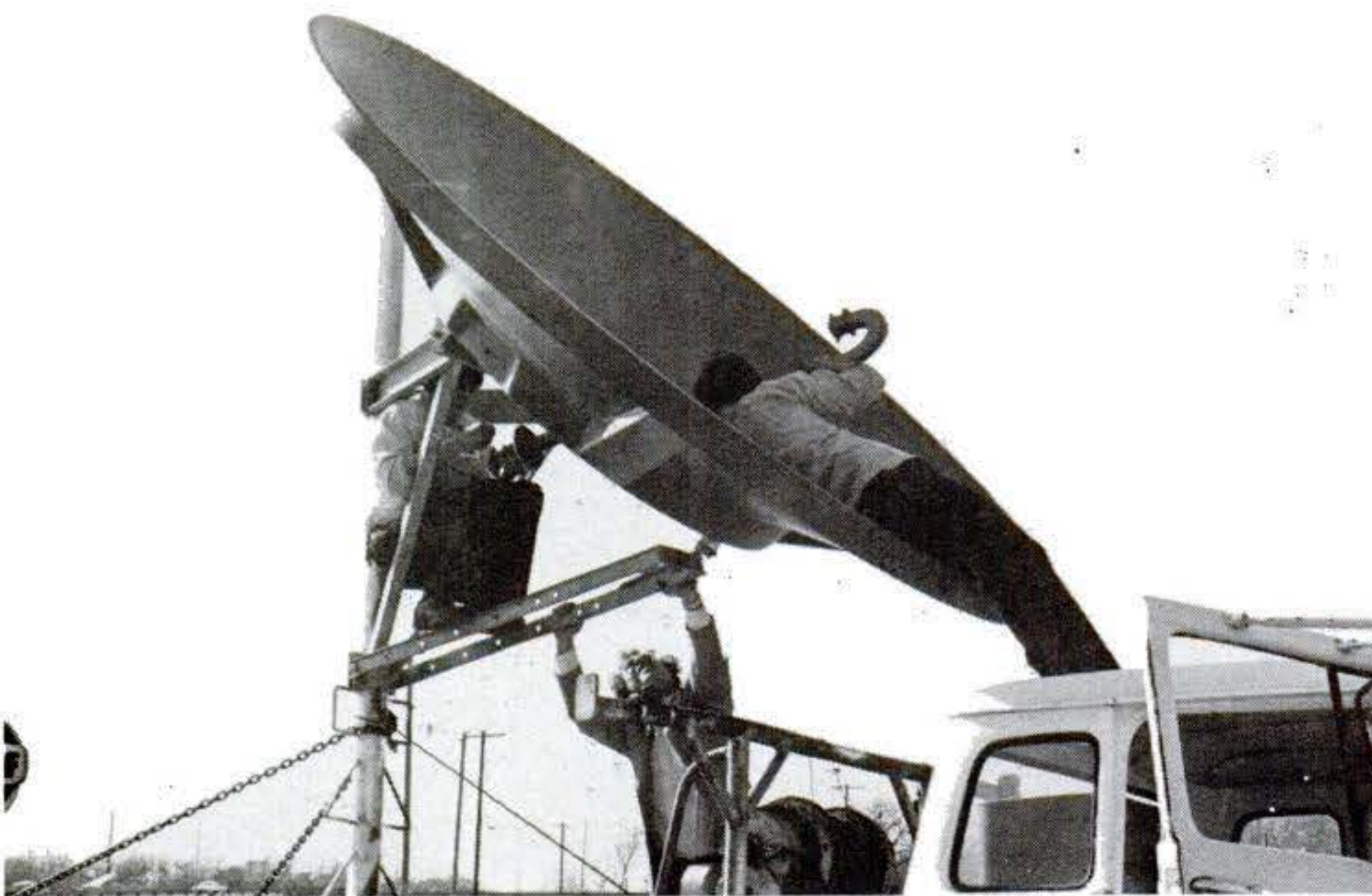

'78] that transmit programs ranging from first-run movies to religious panel discussions.

In the past few years, thousands of TV-starved viewers have been tantalized by this giant carrot in the sky—and some have figured out how to tune in satellite-TV signals. The result: You can now install a private satellite-antenna system that will pick up TV transmissions from domestic communications satellites.

Once huge and supercostly, these antenna systems now fit in an ordinary backyard and their price has moved within range of the folks who can afford luxuries such as an RV or a good boat. The price plummets dramatically if you have the electronics skills and time to cobble a system together.

Still, even if you can buy or build a backyard TV terminal, you can't install one if your site is unsuitable. And although a recent FCC decision makes private terminals perfectly legal, there are still some questions about the legality of picking up transmissions intended exclusively for paying customers. But the fast-developing technology will probably force a resolution of these questions soon.

Celestial eavesdropping

In the early '70's, satellite-TV receivers were used only by governments and Intelsat, the company that runs the international communications satellites. These pre-1975 installations were big and costly, about \$700,000. The coming of domestic communications satellites—and the cable companies that use their services—caused prices to fall. But as recently as late 1976, a terminal equipped to receive just a single TV channel from a single satellite cost \$75,000. By early 1979, commercial terminals were down to about \$15,000.

Meanwhile individual electronics nuts, challenged by the idea of picking up those signals from the sky, began tinkering with homemade receivers. By August 1979 there were enough interested people to pack a three-day satellite-TV seminar held in Oklahoma. There, innovators demonstrated home-designed-and-built satellite-TV terminals that had been put together at do-it-yourself prices—ranging from about \$1000 down to \$200.

Before you consider installing a satellite-TV-receive-only terminal (or TVRO, as people in the trade say), you must consider your location. The antenna has to "see" the satellite in its parking spot above the equator. That means if you're outside the satellite's main footprint area (see map), the antenna may have to be pointed at a very

What's on the satellites

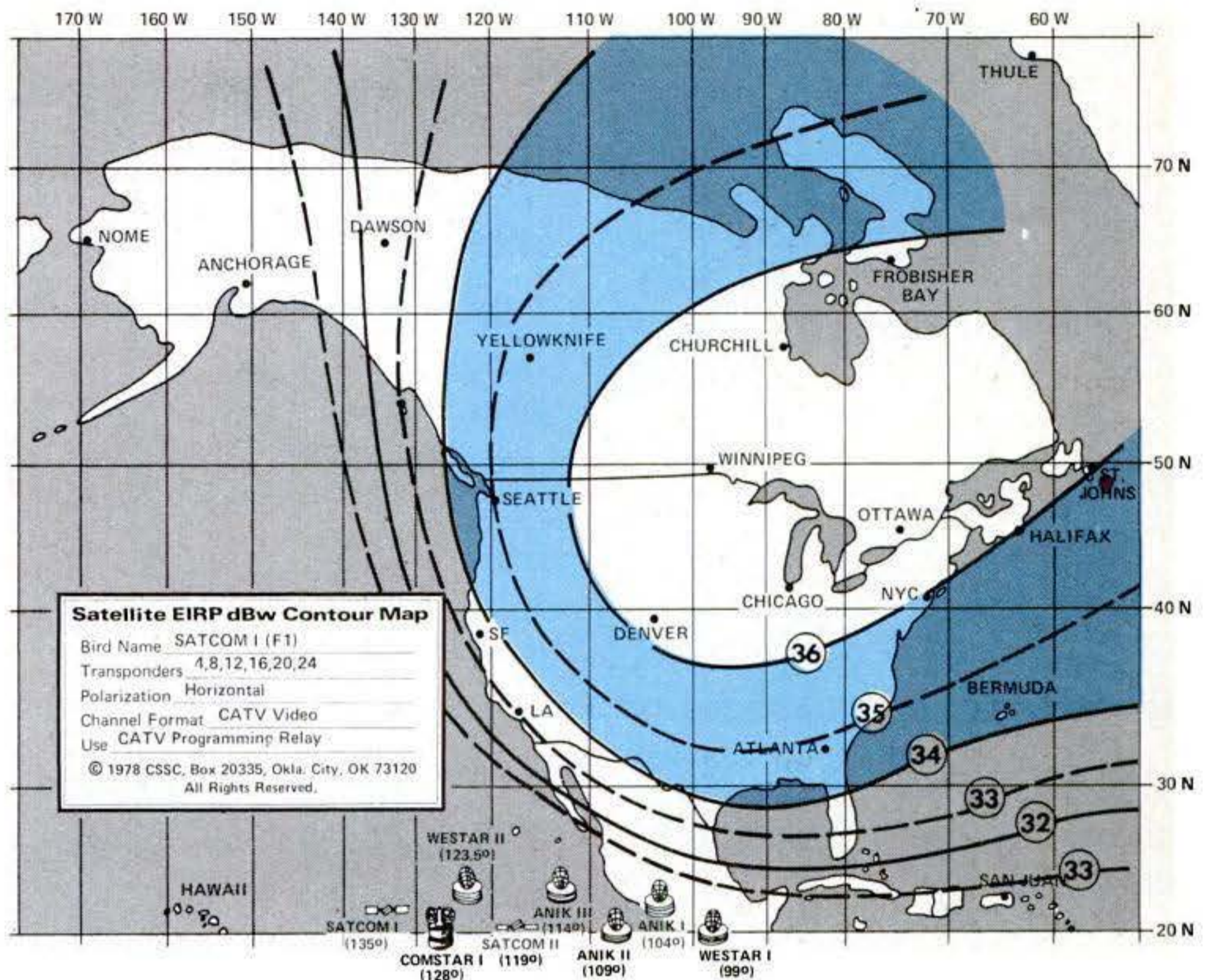

Domestic communications satellites serving North America (bottom of map) hover 35,888 kilometers (22,300 miles) above the equator. At this distance, a spacecraft's orbital speed matches the Earth's speed of rotation, so it remains "parked" at a particular longitude. The contour lines above show the "footprint," or the effective radiated power (EIRP), of one set of transponders or channels on RCA's Satcom 1 parked at 135° W. At any spot on the continent between contours 34 and 36 a three-meter antenna would get high-quality reception from the tran-

Satcom I
 TV station KTVU (San Francisco): 1
 WOR (New York): 17
 WTBS (Atlanta): 6
 WGN (Chicago): 3
 Warner Star Channel: 5
 Entertainment Sports Network: 7
 Christian Broadcasting Network: 8
 Congressional coverage (C-SPAN) and Madison Square Garden sports: 9
 Showtime-West (movies): 10
 Nickelodeon (children's TV network): 11
 Showtime-East: 12
 Trinity Broadcasting: 13
 Fanfare (southwest regional sports and movies): 16
 Praise the Lord: 2
 Various special events: 20
 Satellite Program Network: 21
 HBO-West (movies and sports): 22
 Take-2 (family-movie service): 23
 HBO-East: 24

sponders listed—unless there's something in the way (see text). Residents of areas outside those contours would need a larger antenna. But RCA's two satellites have other sets of transponders that favor different areas of North America. Each of the domestic satellites shown continues to add new programming. (A third RCA satellite, launched in December of last year, was lost in space. It would have provided more channels for new programming ventures.) At PS press time, some of the more popular services available included:

Westar I
 PBS (Public Broadcasting System) network programming: 7, 8, 9
 Several channels of occasional television

Anik III
 English-language program channels: 10, 12
 Occasional CBC (Canadian Broadcasting Corp.) network relay channel: 4
 French-language channel: 8

Satcom II
 Seven channels of occasional television
 NBC network programming: 8
 Alaskan Bush Terminal television: 23

Westar II
 TV station WOR (New York): 1
 WGN (Chicago): 4
 KTTV (Los Angeles): 12
 XEW—Spanish International Network (Mexico City): 7

shallow angle (as low as 10°) in relation to the horizon to see the satellite over the Earth's bulge. At such angles, a tree or tall building or similar obstructions can block the high-frequency satellite signals.

Another problem, especially in urban areas, is interference from numerous ground-based microwave transmissions (local TV signals, police radio, long-distance telephone, etc.). Interference from such sources may make it impossible for you to pick

up the satellite signals with necessary clarity.

But both problems are more likely to apply to the coasts—where there's generally a good selection of TV and cable channels—than to some midcontinent areas, where it's often hard to pull in even one channel.

An advantage of the satellite signals: They are very, very stable with virtually no fading, even in heavy rainstorms. This characteristic

[Continued on page 166]

Welding aluminum

— at last: a way to do it at home

Make full-strength joints using only a propane torch and special rods

By **GORDON GROENE**

When the new metal called aluminum was introduced at the Paris Exhibition in 1855, it was labeled a precious metal: An ounce was worth \$90. Today, aluminum sells for pennies a pound, but it's still one of our most valuable metals for home, shop, recreation, and industry. Yet aluminum has always had one drawback for the craftsman who wants to join or repair it: To weld it you've always needed either oxyacetylene welding with special fluxes or tungsten-inert-gas equipment, plus know-how and luck.

Now word is getting around about a unique (if not exactly new) process that is demonstrated at right by Jim Hille, an inventor and aluminum specialist in DeLand, Fla. With his patented Lumiweld process, aluminum welding comes into the home workshop. You need only a propane torch, Hille's welding rod, and his exacting instructions. Alloys that dissolve heated aluminum have been known since 1928, but Hille experimented with 36 variants of these alloys, chose the best, and came up with step-by-step directions that must be followed for success.

"I call it a process," Hille says, "because the tools and techniques go together. Lots of aluminum solders and welding rods have been on the market, and they've had little success because they just don't stand up." Because Hille has gone after a narrow market—aircraft enthusiasts who weld aluminum in some parts of their home-built planes, and antique-car



Jim Hille demonstrates his Lumiweld process on casting using oxygen-aided torch.

buffs who use Lumiweld to repair pot metal—few people outside these fields know about the process. Nor is his process commonly used by industry, since it's too slow for big production runs.

For a firsthand look, I went to Hille's shop and watched him weld and bend samples of 5052 aluminum of varying gauges and even 2024, which tungsten-inert-gas welders

claim is impossible to weld because heat kills the temper. All the sample welds proved to be stronger than the parent metal, even though bends were done after a short cooling time. (The grain would have continued to grow, improving tensile strength even more over the next 24 hours, Hille told me.) Since then I've used Lumiweld in my

Continued



When your taste grows up, Winston out-tastes them all.

Only Winston's Sun-Rich™ Blend
of the choicest, richest tobaccos
tastes this full and satisfying.

Winston after Winston.

BOX: 19 mg. "tar", 1.3 mg. nicotine, KING: 20 mg. "tar",
1.3 mg. nicotine, av. per cigarette, FTC Report MAY '78.

Warning: The Surgeon General Has Determined
That Cigarette Smoking Is Dangerous to Your Health.



Welding aluminum

[Continued]

own shop with the same results.

The possibilities of Lumiweld for the home shop are many, but I was also interested in it as a portable repair system that could be carried with me on boats, planes, and motor homes.

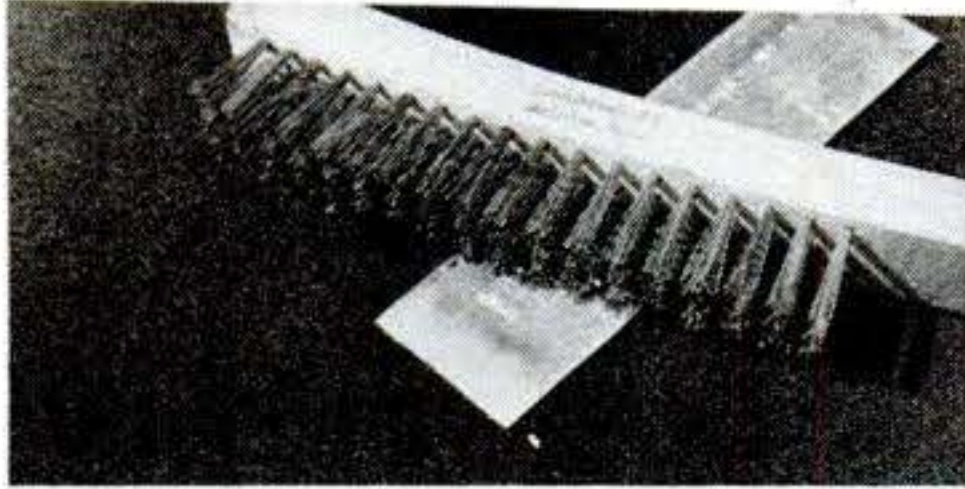

Stainless-steel wire brush is essential to the Lumiweld process, but it must be kept uncontaminated by dirt or other metals.

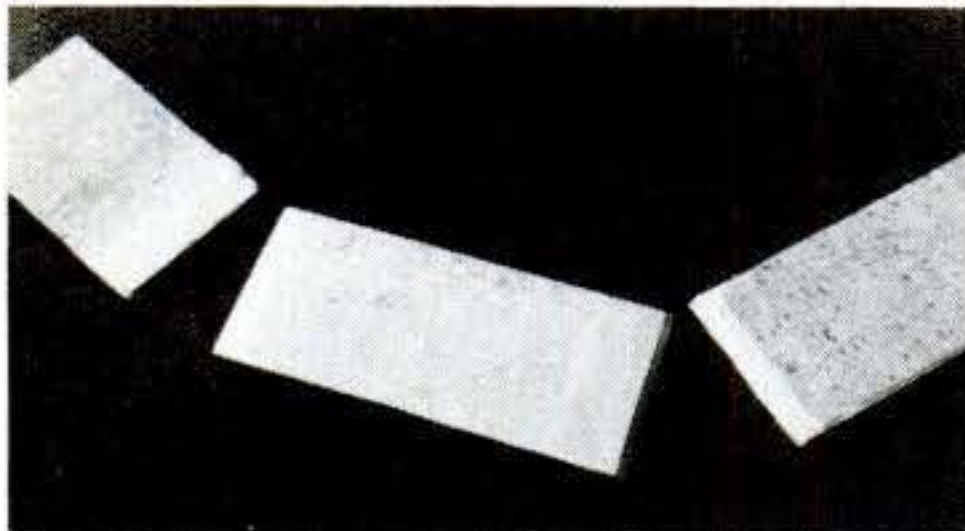

Samples of 5052 aluminum are shown prepared for butt weld (left) and V-weld.

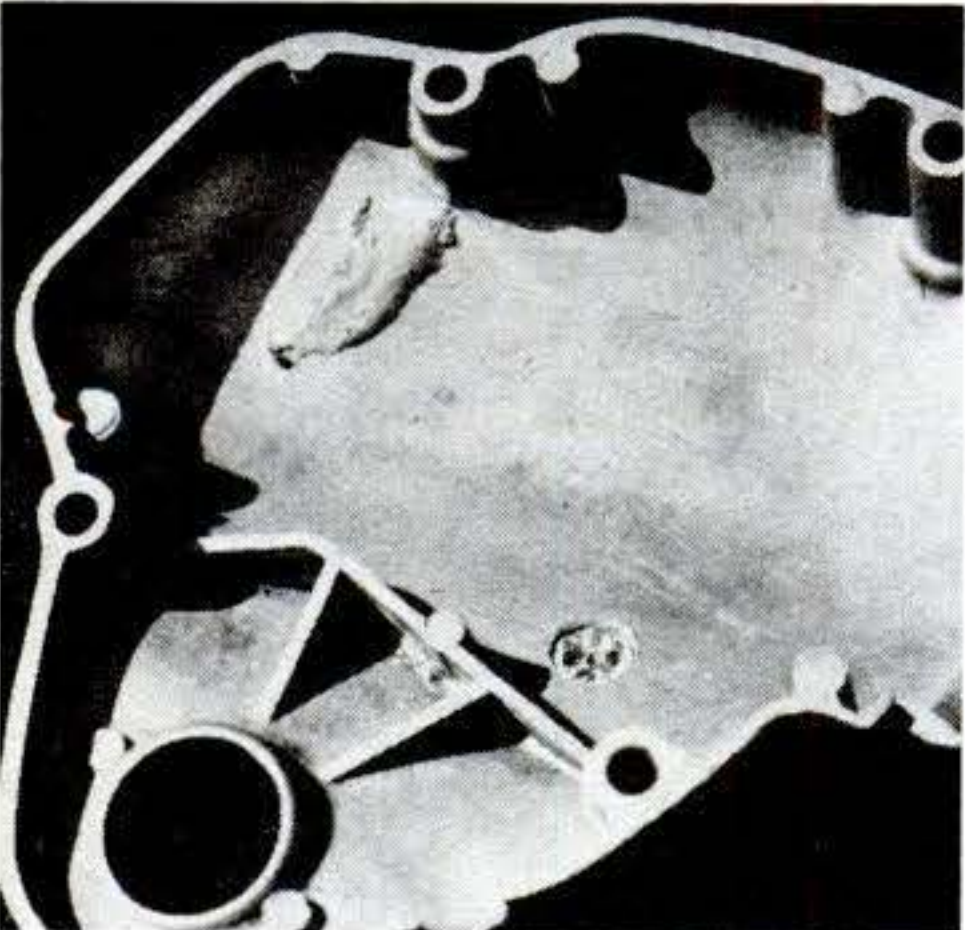

Cast-aluminum repairs should be filled and ground smooth after hardening.

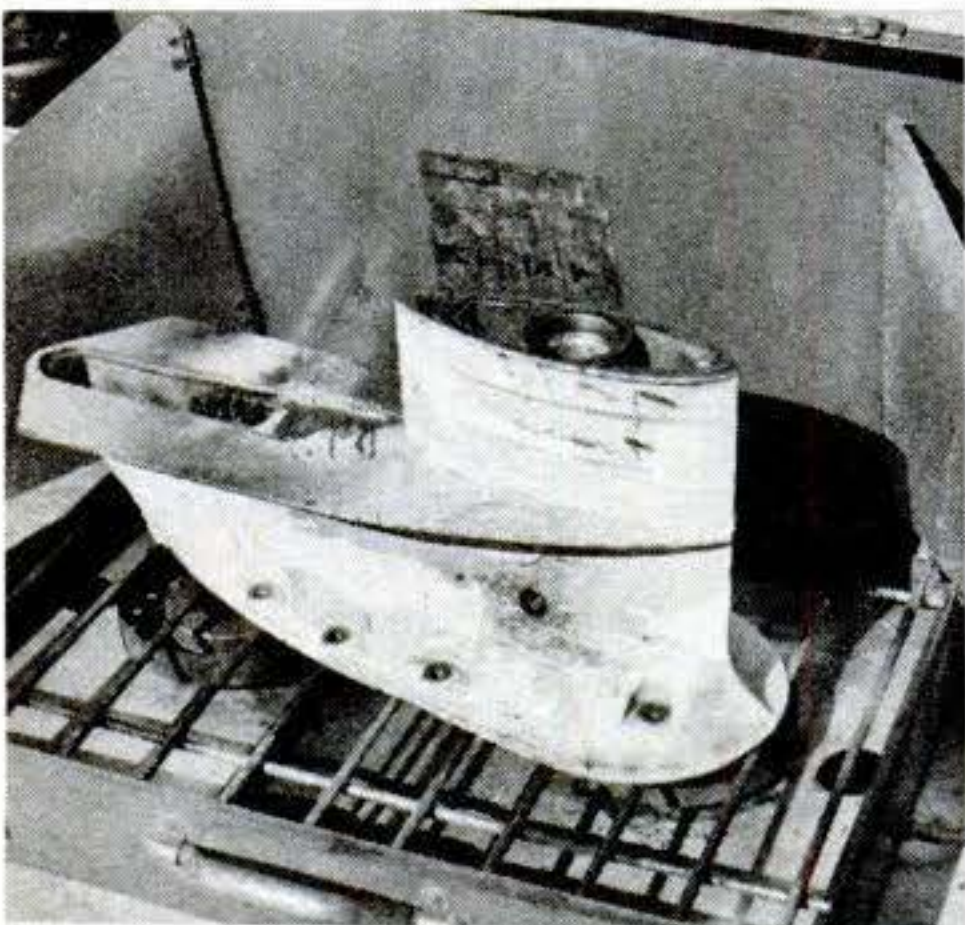

To use Lumiweld on larger castings, the home craftsman needs a propane camp stove or other heat source to help keep the work up to melting temperature of rods.

Anywhere you happen to be—even without 110-V power—Lumiweld can repair a hole in an aluminum boat, a water tank in a remote mountain cabin, holed airplane floats, and broken tent poles.

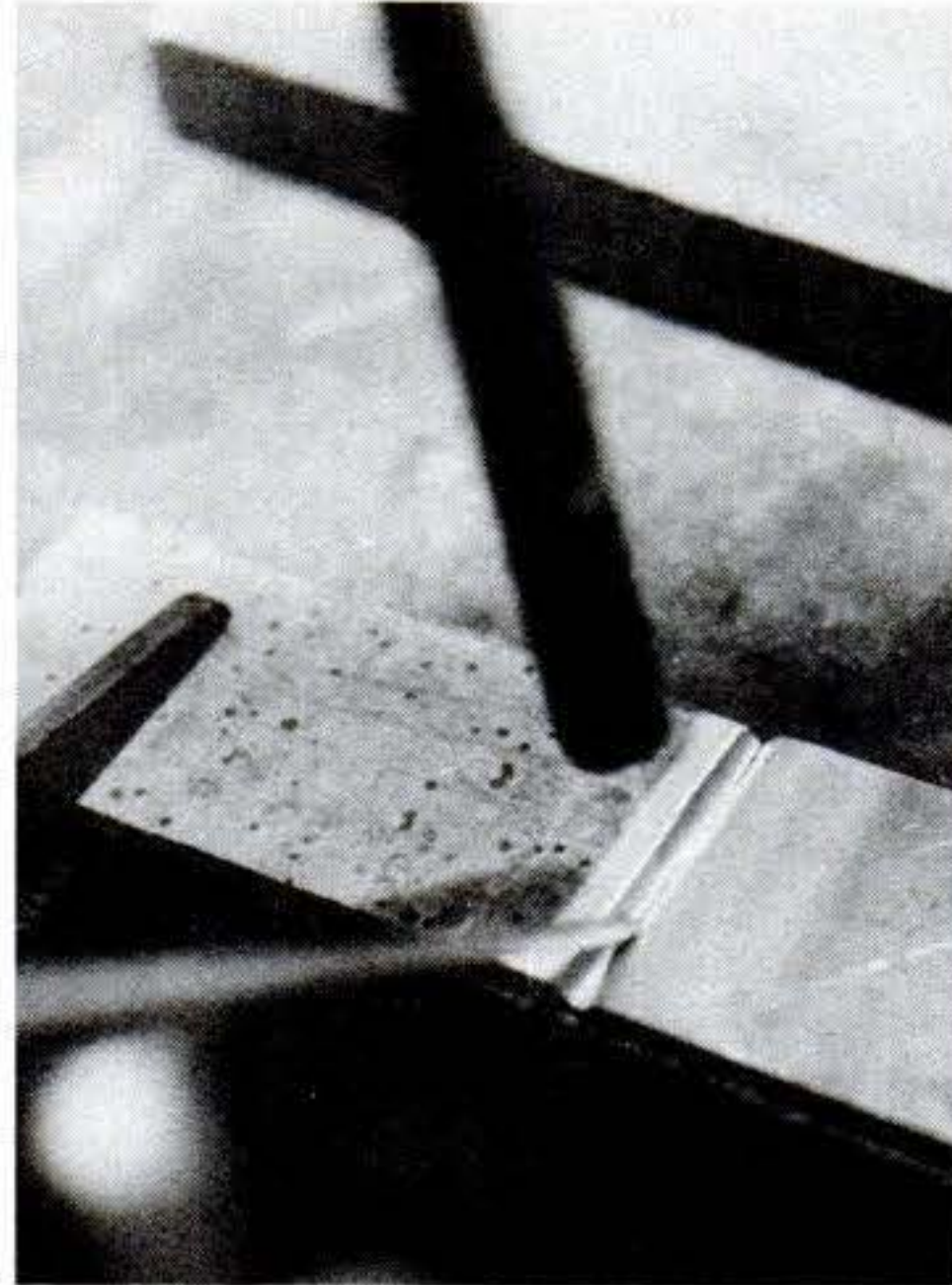

Bead of alloy is applied before scraping.



Not the prettiest joints, but the 5052 butt and V-joints stand up to a 90-degree bend—as strong as the parent metal.

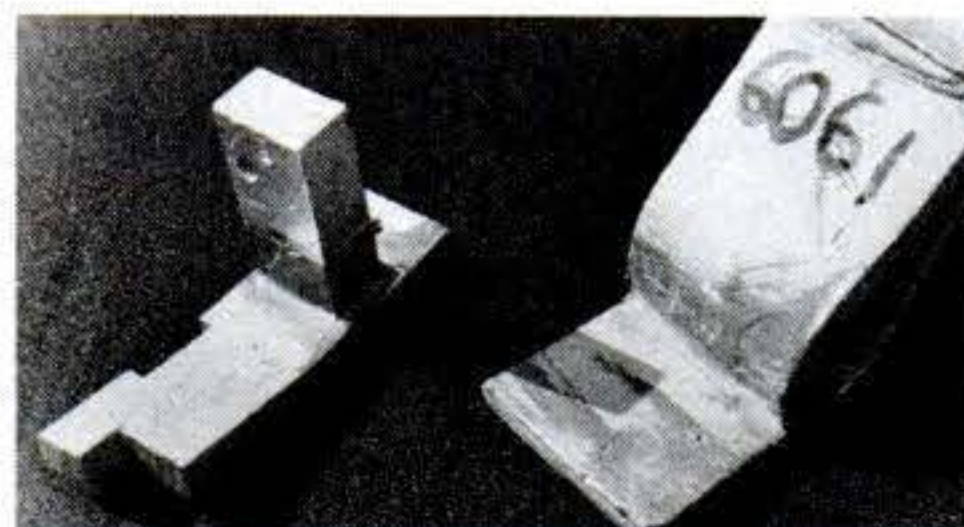

Lumiweld stands up to bend tests on heavier gauges, too. Oxygen-assisted torch may be needed to bring heaviest gauges up to rod-melting temperature.

Anyone who has welded aluminum knows the problems. It doesn't change color or appearance to indicate rising temperature, so you may unexpectedly melt a hole through the work. Oxides are a problem. When aluminum is heated it reacts quickly with oxygen in the air. The resulting layer of oxides prevents bonding and precludes a strong, continuous joint. Also, household products aren't stamped according to alloy grade, so you have to guess which filler rod to use. And the prolonged high temperatures used in conventional welding sometimes render an item unfit for use afterwards. It was all best left to welding experts who had to charge \$3 to \$5 per inch, usually with a job minimum of \$10.

Lumiweld's big advantage is that it is applied well below the melting temperature of aluminum, so you don't suddenly find yourself looking at a big, melted hole. There is no flux. And you use only a propane torch or, with heavier gauges of aluminum, a gas welding torch. The object is to bring the parent or base metal up to only 730 degrees F. Because of the relatively low temperatures and short working time, even heat-treated aluminum items aren't damaged by the Lumiweld process.

Oxides, of course, remain a problem with Lumiweld—as they are with other aluminum welding techniques. The difference here is that you heat the parent metal enough to melt the Lumiweld rod, and then scrape away oxides under a pool of melted rod while fusion is taking place.

The Lumiweld process

The first pleasant surprise with Lumiweld is the price. The rods cost \$12 for 72 inches or \$21 for 360 inches, and this includes shipping. You'll also need the special stainless-steel wire brush that is important to Hille's process. That's \$5.

When you order Lumiweld, you also get complete, illustrated instructions which Hille has developed from years of working with his own products and with amateur, first-time welders. Even if you know other welding and soldering techniques, it's important to follow Hille's directions. Briefly, the steps are:

(1) Clean the weld surface with a stainless-steel brush and/or aluminum oxide sandpaper. It's essential that the surface be clean and uncontaminated by other metallic ions; that means a thorough cleaning with a brush that is never used on any metal

Continued

Lost in a blizzard!



For a daily Olympic update compliments of C.C., dial 800-223-1850. In N.Y. dial 212-888-0766.

We came to bury a case of C.C.[®] near the site of the Winter Olympics...and almost got buried ourselves.

We headed to Lake Placid to cross-country ski and to hide a case of C.C. near the Winter Olympics. But skiing deep into the forest, we forgot to watch the sky.

A serious mistake among the unforgiving Adirondack Mountains.

By noon the wind was howling and, faster than we could believe, the ski tracks we hoped to follow were under new snow. We were lost in an Adirondack blizzard! But intent on hiding our case of Canadian Club, we blindly followed our sixth sense. Finally, cresting a steep hill, we found ourselves in an open field. Driving winds were more intense here, but we followed a fence row until we could make out the silhouette of towering Whiteface Mountain. With our bearings restored, we hid our treasure in a place where those who seek gold will miss by a quarter of a mile.

Toasting our luck with C.C. before a roaring fire.

Soon we were regaling friends with our chilling adventure as we enjoyed drinks of Canadian Club before a warming fire. We knew the case wouldn't be easy to find. Those who seek it may have to brave the same bitter conditions that challenge the Olympians. But if you prefer to confine your search for "The Best In The House" to the warm fireside, simply tell your host, "C.C., please."

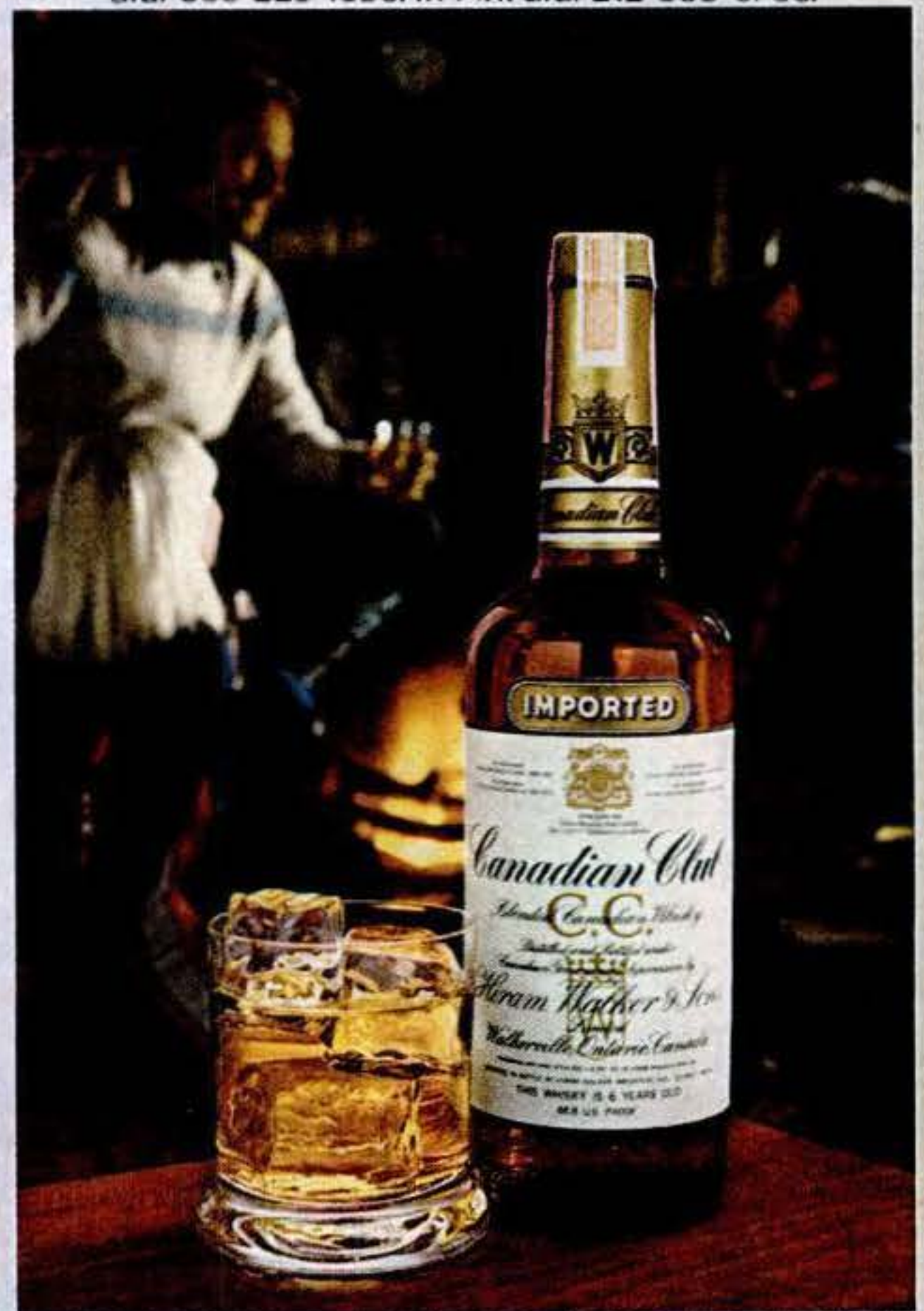

6 YEARS OLD. IMPORTED IN BOTTLE FROM CANADA BY HIRAM WALKER IMPORTERS INC. DETROIT, MICH. 86.8 PROOF. BLENDED CANADIAN WHISKY. © 1980

Canadian Club

"The Best In The House"® in 87 lands.

Copyrighted material



“We learned our lesson with that last tractor we had. This time we got a John Deere.”

Laurence Light, Redfield, Iowa

A few years ago, Laurence Light bought a “bargain” lawn and garden tractor figuring he might save himself a little money.

Unfortunately, it didn't work out that way.

“That cheap tractor never did do the job,” according to Mr. Light. “So last year my son Harry and I bought a John Deere.”

It's a story we hear all the time at John Deere.

People switch to our tractors because they know we build them strong enough to do the jobs you expect a tractor to do. And solid enough to keep on doing them long after others have worn out.

“You can actually feel the difference in a John Deere,” says Light. “We use ours for tilling in spring, mowing in summer and clearing snow in winter. And we love it.”

Test drive one yourself at your nearby John Deere dealer.

Down-to-Earth Value. Save 25%.
By buying a 200 Series tractor before May 31 at a participating dealer, you can save 25% on the following attachments: rotary mower, snow thrower, front blade, rotary tiller or dumpcart.



For more information, write John Deere, Department 50, Moline, Illinois 61265.

Nothing runs like a Deere®



Welding aluminum

[Continued]

but aluminum. Hille even recommends keeping this brush wrapped in aluminum foil.

(2) The next step is to heat the base metal, using a standard propane torch, until it reaches 730 degrees F and can melt a Lumiweld rod. At this point the heated base metal will have formed oxides on its surface. You then back off the heat, because at 790 degrees F Lumiweld begins dissolving



2024 aluminum can't be welded with conventional methods; Lumiweld can do it.

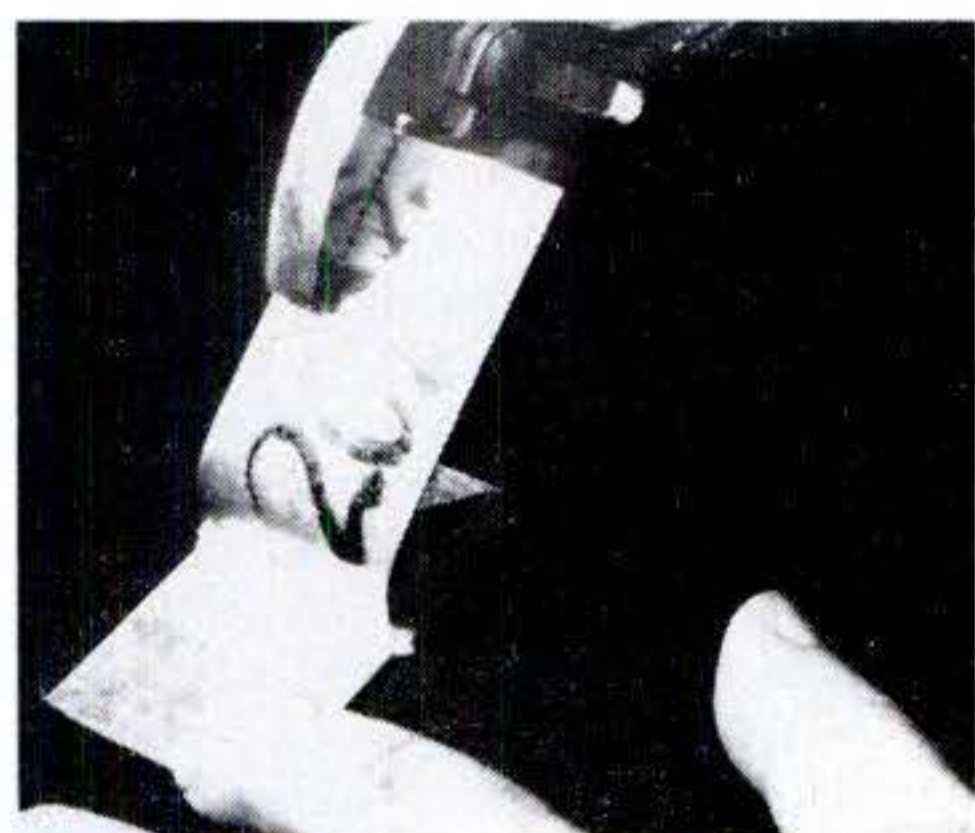

2024 T-joint is given a bend test above.

the aluminum too rapidly. You have to develop a good feel for keeping the temperature high enough to allow penetration, but low enough to give you time to work. The bonus here is that the aluminum itself doesn't melt below 1100 degrees F, so you have a 400-degree margin to work with.

(3) Cover the surface where you want penetration with a layer of Lumiweld. This is comparable to the step in inert-gas welding where an inert-gas envelope is introduced to keep reactive air away from the hot aluminum.

(4) Now the oxides on the base-metal surfaces are removed. You can fashion a stainless-steel scraper, or, with smaller jobs, just scrape with the cold end of a Lumiweld rod. The biggest mistake Hille sees during this step is that those who are accustomed to soldering simply dab with the rod. It's important to scrape vigorously.

(5) Now fill or bridge the joint with a fillet of Lumiweld to the thickness which will provide needed strength. You want it high enough to be strong but not so thick that you'll spend time later grinding it down. For small holes, a bridge of Lumiweld can be used. For larger ones, use a patch.

(6) Let the weld cool at room temperature. Quenching can weaken the joint. After cooling, Lumiweld can be ground, machined, drilled, tapped, or painted.

While this is a summary of the steps Hille recommends, it's not intended to be a how-to. For that, you'll need Hille's brochure, which includes many more helpful suggestions, directions for using Lumiweld with pot metal, and hints for special jobs such as bridging, building up a new edge, and replacing stripped threads. It's a good idea to do some practice welds and then build up your skills before tackling difficult repairs or major construction projects. In lap welds, for example, you can't remove the oxides while flowing Lumiweld into the joint. So you copy the soldering technique of

Continued

Properties of Lumiweld

| | |
|--|--|
| Rockwell B hardness | 55-65 |
| Ultimate tensile strength | Greater than base aluminum, up to 40,000 psi |
| Compressive strength | 55,000-78,000 psi |
| Shear strength | 18,000-33,000 psi, depending on joint design |
| Endurance limit | 100 million cycles at 8000 psi |
| Specific gravity | 6.7 |
| Corrosion penetration (New York City) | Less than 0.0003 in. per year |
| Electrical conductivity | 25 percent of copper |
| Working temperature | 730 degrees F (390 C) |
| Dimensions of rod | 1/8-in. dia. x 18 in. |

Stop winter sliding door problems cold!

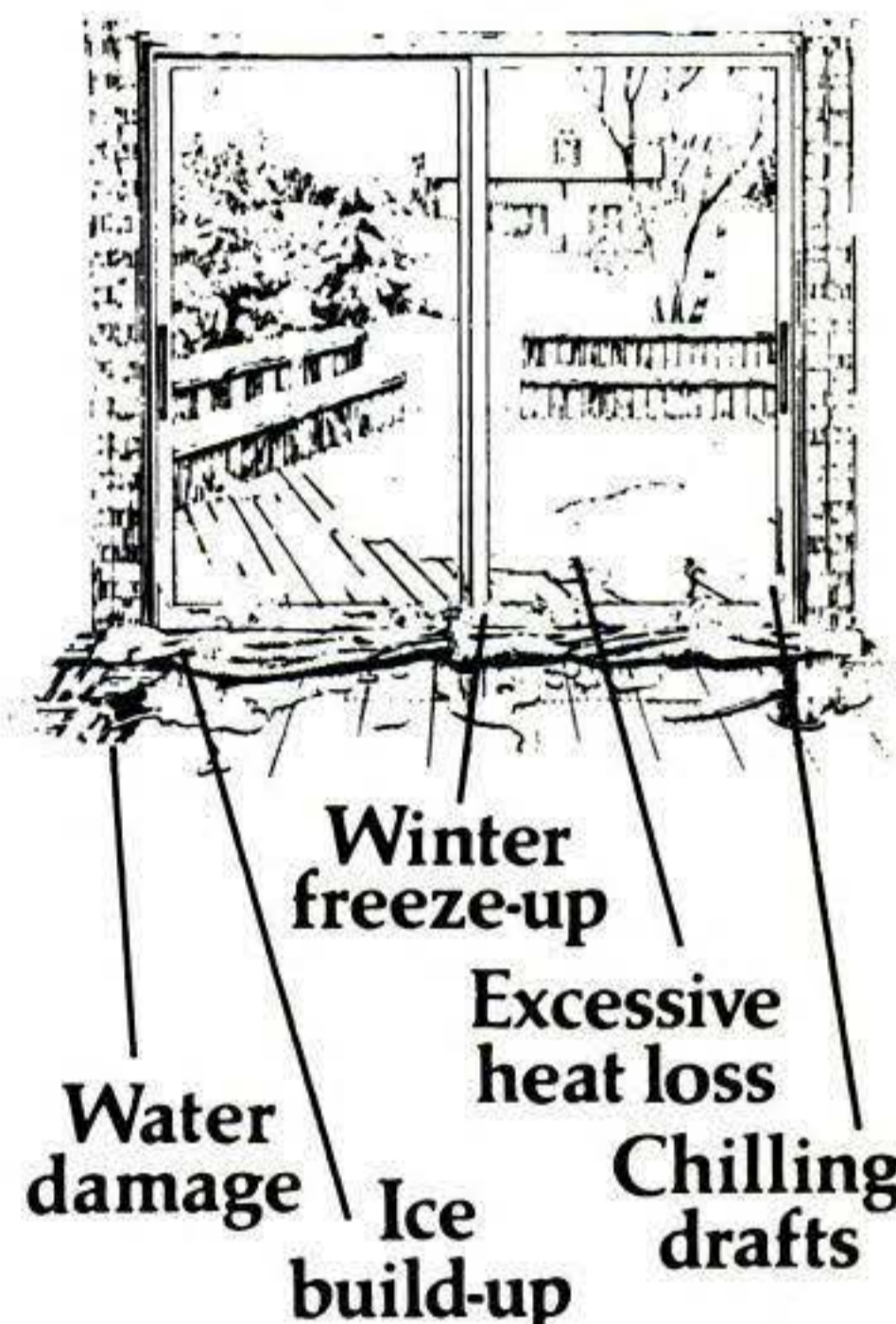

Andersen introduces a new low-maintenance Perma-Shield[®] gliding door especially sized to replace most six-foot wide metal sliding doors. In most cases, without structural changes, reframing or resizing your existing door opening. Make the change. And stop winter cold!

The facts are

FREE!

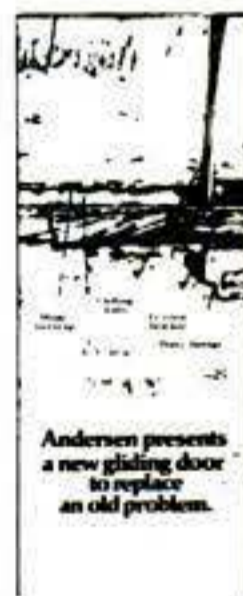

Please send your free booklet "Andersen presents a new gliding door..." Mail to: Andersen Corp., Box 12, Bayport, MN 55003.

Name _____
Address _____
City _____ State _____
Zip _____ 022-030

The beautiful way to save fuel™

Andersen Windowalls



8008 Copyright © Andersen Corp. Bayport, Minn. 1978

ON YOUR NEXT VACATION, TAKE ALONG SOME GOOD BOOKS.



The North Carolina Travel Package. It's full of hard facts, not soft soap. Facts about where to go, where to stay, and what to see in North Carolina.

Just send the coupon, for your free Travel Package. Then come, and bring it with you. And you'll never have to worry about finding something to do.

Name _____ Address _____
City _____ State _____ Zip _____

North Carolina Travel Package

North Carolina Travel, Department 379, Raleigh, North Carolina 27699.

Welding aluminum

[Continued]

tinning each edge while scraping away oxides, then joining the two by reheating, adding more rod if needed.

A word about terminology: Hille's application has many similarities to soldering, and since it doesn't join metals through heat, it may be claimed that he is not really welding. Still, the aluminum is dissolved molecularly and is actually fused as in any weld—which is why I call it a weld and not a solder. Whichever term is applied, in my tests with this process the parent metal breaks before the weld—and that's what counts.

Limitations of Lumiweld

Lumiweld does have its drawbacks, and one of my first questions was about electrolysis because I'd be using it on a boat in salt water. "Lumiweld contains zinc, so it's subject to galvanic action," Hille admitted. "But in many cases that can be useful. Using Lumiweld sacrificially will protect the aluminum, even though you'll have to redo the weld after a time."

One common boating use for Lumiweld is to build up the leading edges of aluminum propellers, which abrade quickly in sandy waters. It's cheaper than buying new props or having old ones ground and rebalanced, even though the Lumiweld has to be replaced as it wears from abrasion and electrolysis.

Another problem with Lumiweld is that it can't be anodized; also, it won't work on anodized aluminum unless the anodized coating is removed. (Anodized aluminum looks as if it has been painted—as on new storm windows or doors—although the coating is actually a result of a chemical reaction with the metal's surface.) Lumiweld can't be heat-treated. It is heavier than aluminum, so you should use as small a bead as possible where weight and balance are factors.

Overhead work with Lumiweld (as with solder) is very difficult; it can also be messy when you're working on a vertical surface. Tubing is very tricky to weld, so don't tackle it until you've had plenty of practice. Long runs may crack as they cool. Rather than spot-welding the entire length, work slowly from end to end.

As you work with Lumiweld, keep in mind that the base metal will be at least 730 degrees and that heat travels quickly through aluminum. Take care not to damage nearby seals, paint, varnish, plastics, or wood.

For information about your nearest dealer, write Alumismiths, Box 517, DeLand, Fla. 32720.



FINANCING
NO
PROBLEM!

Have you been priced out of today's housing market?

Miles Homes could be the answer!

If you have the ambition and desire to build your own home, then the Miles Plan could be for you. **THE MILES HOME OWNERSHIP PLAN IS UNIQUE.** Your desire and dedication are more important than ready cash — start now to build the home of your dreams... the Miles Way.

- Liberal credit — Low monthly payments while building.
- Foundation assistance.
- Land may not have to be fully paid for.

- Pre-cut materials, blueprints, step-by-step instructions.
- 36 months to build.
- There is a representative near you. Phone: (612) 588-9700.

Miles has nearly 30 years experience helping over 15,000 families to build their own home. Send coupon today to see how Miles can help you.

Miles Homes

12 Insilco A Division of Insilco Corporation

Send me your FREE Great Homes Idea Book
MILES HOMES, Dept. 0310
4500 Lyndale Ave. N., Minneapolis, MN 55412

Name _____

Address _____

City _____ State _____ Zip _____

County _____

Phone () _____

I plan to do all or part of the work
 \$1.00 enclosed for priority handling

MPSO

Read this Ad next time you're drowsy and dragged out at three in the afternoon.

More and more research shows ion-deficient air is a major cause of drowsiness

That invigorating feeling you get from a walk in the mountains is the work of electrically charged air particles called negative ions.

Negative ions are nature's air cleaners, removing polluted particles from the atmosphere.

In the city - and in offices, homes and cars, the natural negative/positive ion balance breaks down, leaving you with far too many energy-sapping positive ions to breathe.

The resulting drowsiness causes reduced productivity in your home or office. And, in your car, where ion deficiency is even greater, it is not exaggerating to say that the atmosphere can be downright dangerous.

How ion deficiency affects you

While we don't yet know all we want to about the effects of ions, we do know this much.

Air conditioning, central heating and pollution strip beneficial negative ions from the atmosphere. This helps to explain why so many office workers and housewives complain of the blahs in mid afternoon. Breathing bad air is bad news.

The same thing applies to your car. Only more so. Compare your car's ion balance (about 80 to 100 negative ions per cubic centimeter) to that of fresh mountain air (1,000 to 5,000 negative ions per cubic centimeter.)

No wonder drivers become sluggish and irritable. This atmosphere is not only unhealthy. It's dangerous. Especially when you consider that ion-deficient air slows reflexes by as much as 20%.

More negative ions mean more energy and alertness

Wherever ionizers have been tried, they have changed things for the better.

People have reported greater energy, better health and increased productivity.

An ionizer replaces the negative ions killed by metals, man-made materials, air conditioning and central heating. It restores the natural balance of the air, making it fresh and easy to breathe. At the same time, an ionizer radically reduces airborne dust, pollution, bacteria and pollen. And almost completely eliminates stale odors like tobacco smoke. Naturally.

You feel better and more alert. So think what it can do for you if you have allergies.

Why you should choose Bionaire ionizers over any other models

Many ionizers on the market emit ozone or other harmful gases. With Bionaire, all you get is a pure, invigorating stream of negative ions.

Another frequent problem is TV, CB and radio interference. You'll get no static with a Bionaire unit. It just quietly does its job.

The Bionaire 100A for your office or home

This unobtrusive, decorator-designed unit ionizes an area of approximately 250 sq. ft.

BIONAIRE 300
CAR UNIT 1" x 4" x 3-1/2"



BIONAIRE 100A
HOME/OFFICE UNIT 2-1/2" x 6" x 6"

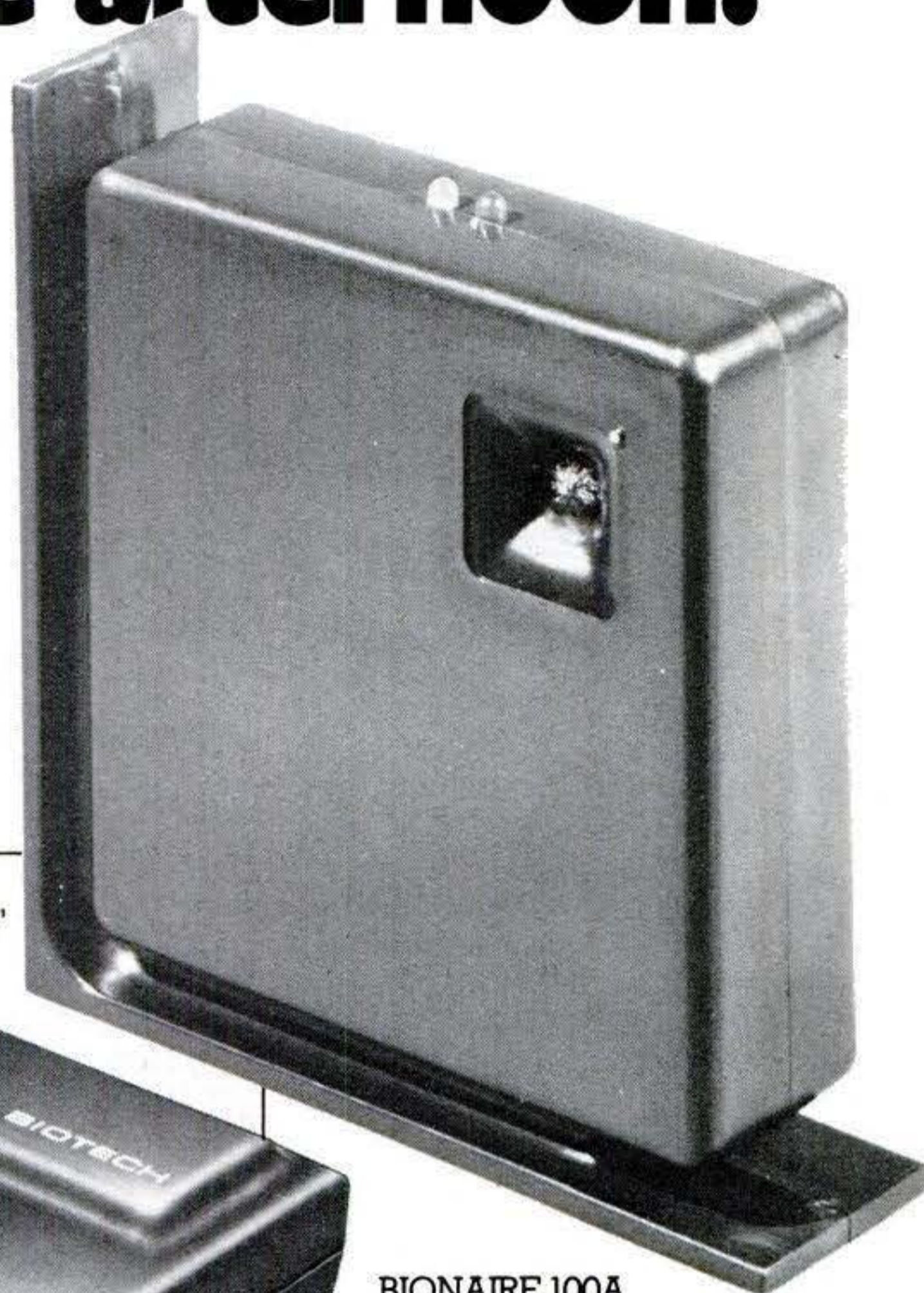

It comes complete with unique output monitor indicators, omnidirectional emission, and a full one-year warranty.

The Bionaire 300. Consider it a safety device for your car

As mentioned, ion-deficient air slows reflexes by as much as 20%.

This can mean all the difference between avoiding a dangerous situation, and running right into it.

The compact Bionaire 300, (1" x 4" x 3-1/2") weighs only 4 ozs., sits on the dash without obstructing your view, and will keep you calm and alert through those endless rush-hour drives.

It's easy to install, has a multi-point ion source, and emits the highest ion output of any self-contained unit of its size. It also has a full one-year warranty.

Each Bionaire unit keeps the air in an 8 ft radius around it charged with at least 10,000 negative ions per cubic centimeter.

Would you like to know more?

If you'd like to read the latest scientific facts about ions, and learn more about these exceptional Bionaire units, we'll be

glad to send you some very interesting literature including an article from P.379, December Playboy. Just mail us the coupon below.

Or do you know enough already?

Credit card holders: If you're convinced of the benefits Bionaire can bring you, order your home or car unit by calling 416-363-8704 collect.

B-V Distributors

P.O. Box 510, Grand Island,
New York 14072, Dept. 107

At no obligation, please send me
free, the full scientific facts on:

- Bionaire 300 (Car unit)
- Bionaire 100A (Home/office unit)

NAME _____

ADDRESS _____

CITY _____

STATE _____

ZIP CODE _____

Day's book *How to Service and Repair Your Own Car* has been published in an updated edition at \$14.95 by Popular Science Books.

Trouble-shooting your car's charging system

By RICHARD DAY

Your car's battery is the heart of its electrical system. Sometimes batteries die because they're simply worn out. But sometimes they die because the charging system isn't doing its job properly.

If your battery is weak or dead, but still recharges and checks out okay, you'll have to trouble-shoot the car's charging system.

First, check for loose, cracked, glazed, or broken belts, and loose or corroded electrical connections (especially at the battery terminals). If everything's fine here, more sophisticated trouble-shooting is called for. With a voltmeter, ammeter, battery-post adapter, and a short jumper wire, you can do a lot or all of it yourself.

You'll also want a shop manual for the make and model of your car. It will give you specs and exact procedures for trouble-shooting your particular vehicle.

Basically, this requires checking the charging system's output (in both volts and amps). While a voltmeter and ammeter work well for this, Sun's recently introduced CP-7660 Engine Analyzer is even more convenient. Single-meter testers make you switch back and forth to get volts and amps. With the Sun unit you can read volts and amps simultaneously.

Alternator precautions. When testing the charging system with the engine running, be sure to keep yourself and the tester leads out of the way of rotating parts. What's more, don't short across any alternator terminals, except as specifically directed. And never run the engine with the alternator open-circuited; the output (BAT) terminal should always be connected when the engine is run. Be sure that

Basic charging-voltage test

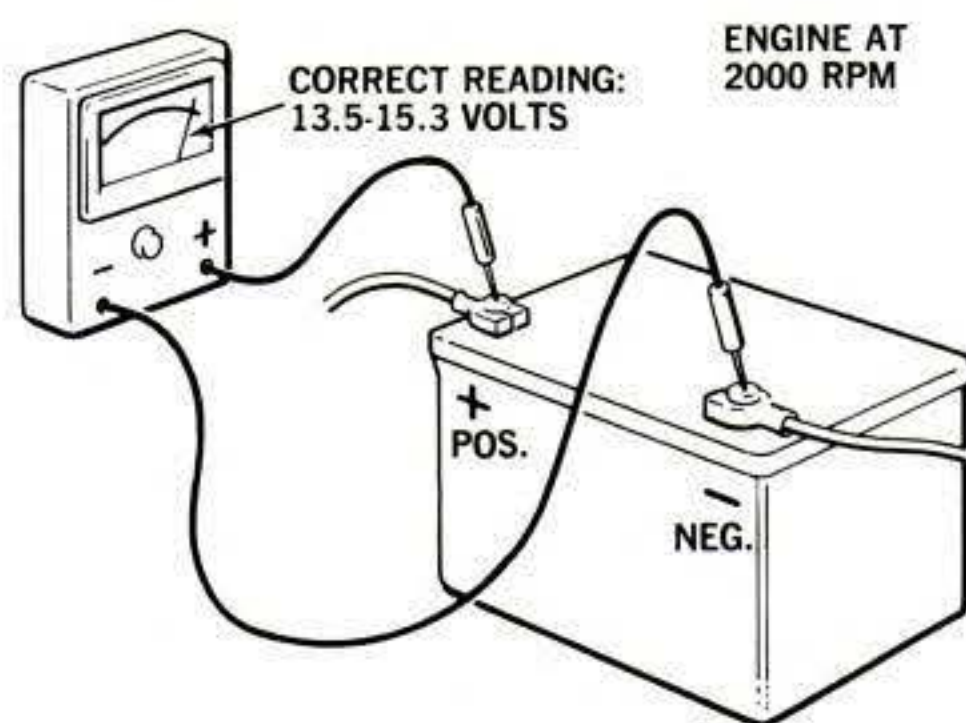

A voltmeter with 16-volt scale puts you in business for a basic charging-system checkout. Connect its leads across the battery posts, observing polarity. It should read about 12.5 volts with the engine not running, increase about two volts as the engine is started and run up to 2000 rpm (about a 35-mph equivalent). No voltage increase means that the battery is not being charged. Either the alternator or the regulator can be at fault, but first check for possible mechanical problems, such as loose belts and loose or corroded connections.

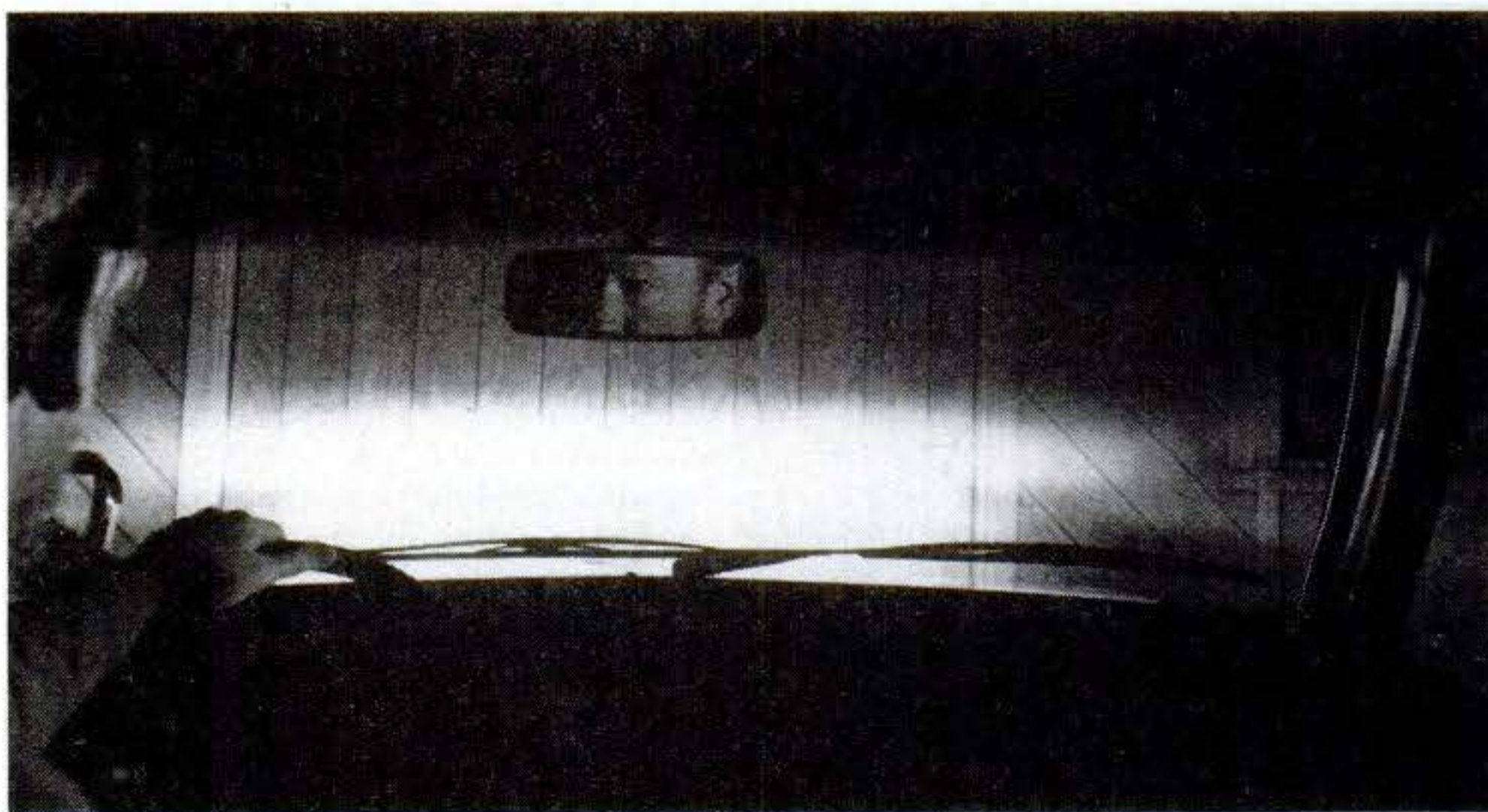

both the alternator and battery have the same ground polarity—usually negative. Before removing or replacing the alternator, regulator, or exposed leads, remove the battery's ground terminal to prevent accidental short circuits. And never polarize an alternator; it doesn't need it, and can be damaged.

On the following pages, we show how to perform the basic tests that will tell you what's wrong. And there's a checklist of symptoms and causes.

Even without a voltmeter, you can approximate the basic charge/no-charge checkout against your garage door at night. If the headlights brighten and dim slightly as the engine is speeded and idled, the system is charging. No brightness difference means no charge. On the other hand, excessive brightening indicates an overly high charging rate.

For additional trouble-shooting procedures, see page 134 and following pages

Warning: The Surgeon General Has Determined That Cigarette Smoking Is Dangerous to Your Health.

©1980 R. J. REYNOLDS TOBACCO CO.



The Vantage Point

Where great taste and low tar meet



FILTER 100's: 10 mg. "tar", 0.8 mg. nicotine, FILTER, MENTHOL: 11 mg. "tar", 0.8 mg. nicotine, av. per cigarette, FTC Report MAY '78.

You don't have to be a professional..

(to be a do-it-yourself expert)



ARROW HEAVY DUTY **STAPLE GUN**

SHOOTS A STAPLE
WHEREVER YOU'D DRIVE A NAIL!
faster .. better .. cheaper ...

Whether you're installing insulation ... re-upholstering a chair ... repairing a screen ... covering a cornice ... securing an antenna wire — there's no faster, easier or more efficient way to get the job done than with a one-hand operated Arrow automatic staple gun.

Arrow Staple Guns come in a variety of models,

At all leading Hardware, Home Center & Discount Department Stores Everywhere.

ARROW FASTENER COMPANY, INC., 271 Mayhill Street, Saddle Brook, N. J. 07662



Portable Steam Cleaner

Steam in 60 seconds

CLEAN:
Engines, Air Filters, Lawn Mowers.
3 year guarantee on fire box, coils. Uses liquid soap, propane fired. Weight 120 lbs. Auxiliary pump required on low water pressure.

WEDCO MFG. INC., Dept. S-8,
Scott Lane • Box D, Jackson, WY. 83001

SEA EAGLE[™] INFLATABLE BOATS

Quality canoes, dinghies and motorboats. From \$60. to \$1800. All pack small. All give years of reliable service.



Send for FREE color brochure.
Sea Eagle, Dept. PS-3, St. James, New York 11780

SpeakerGuts.

The absolute latest in advanced speaker technology. Wave Aperature Drivers, the Patented Netrovic Woofer System, raw speaker components selected for their excellence. Horns, crossovers, subwoofers, woofers, midranges, horn and dome tweeters. Over 30 in all. Build your own speaker system and we'll provide top quality speakers and design information. Send for FREE 48 page color catalog from the largest, most experienced speaker kit manufacturer in the world. **DON'T DELAY. Write today!**



Dept. 187, 735 N. Northlake Way
Seattle, Washington 98103

INVENTIONS WANTED

On behalf of our client, a Fortune 500 company, we are looking for inventions with potential application in:

- Health Care
- Recreation
- Filtration
- Fluid Flow
- Electric and Hydraulic Controls
- Heat Exchange and Combustion
- High Pressure Pumps and Valves
- Control Valves

We are interested in patented or patent pending inventions only. Since our client is paying for this search, there are no fees or expenses to you, the inventor. If you care to submit an invention, please send it to:

Frard & Associates, Inc.
P.O. Box 12222
Cincinnati, OH 45212
(513) 631-0100

Charging systems

[Continued]

If charging check is negative, you'll need to determine next whether the alternator or the regulator is at fault. An output test, sometimes called the full-field alternator test, will tell. To make it, the regulator's voltage-controlling function is bypassed with a jumper lead. It's like opening the damper and draft door on a wood stove and letting it run wild.

Where you connect the jumper depends on whether your car has an electronic voltage regulator, usually integral with the alternator, or a separately mounted

Continued

Typical output-test hookups

SEPARATE RELAY-TYPE REGULATORS

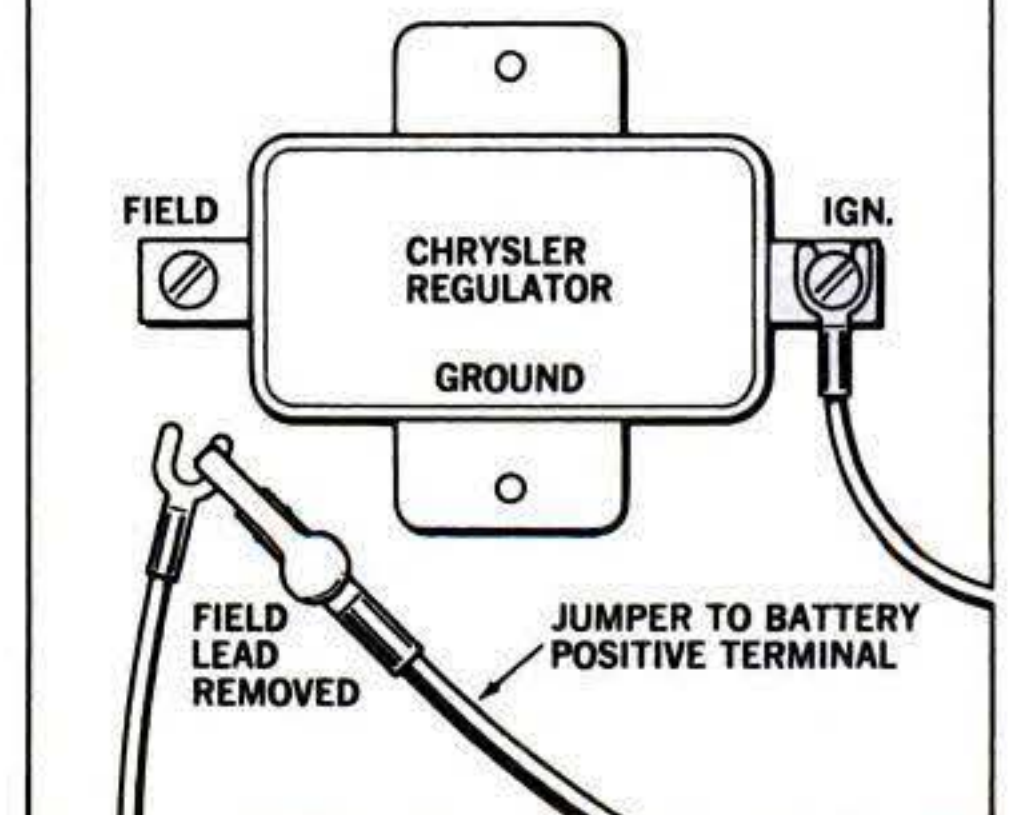
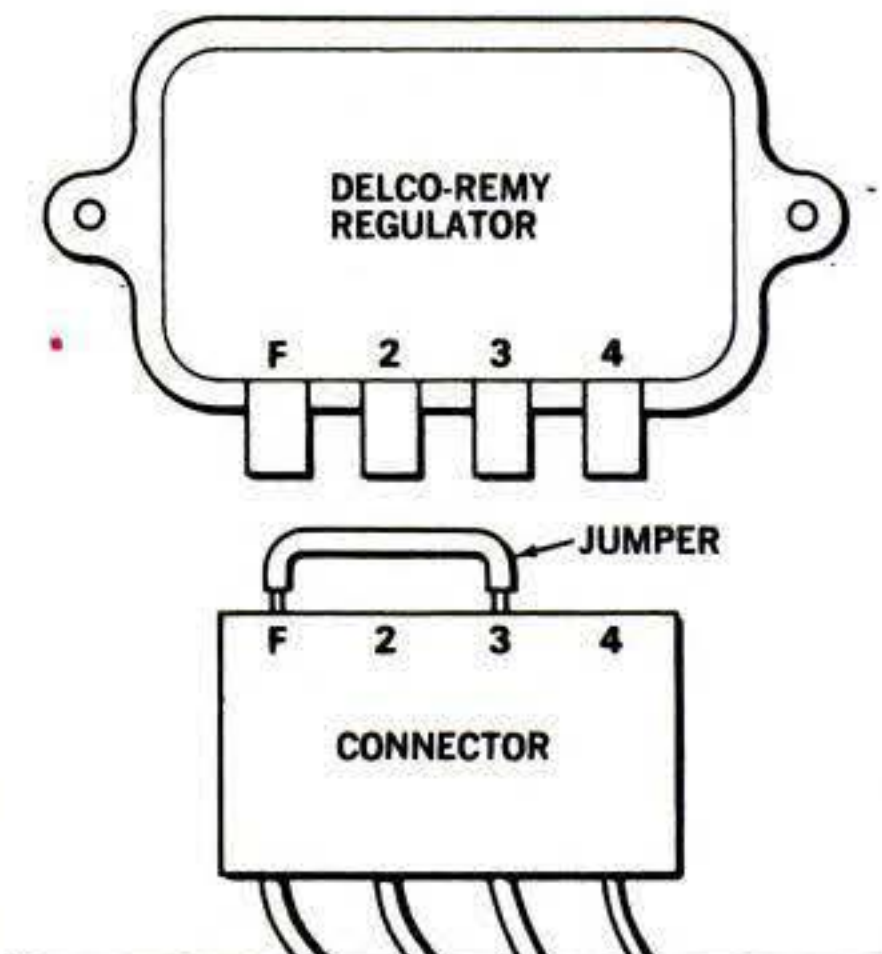
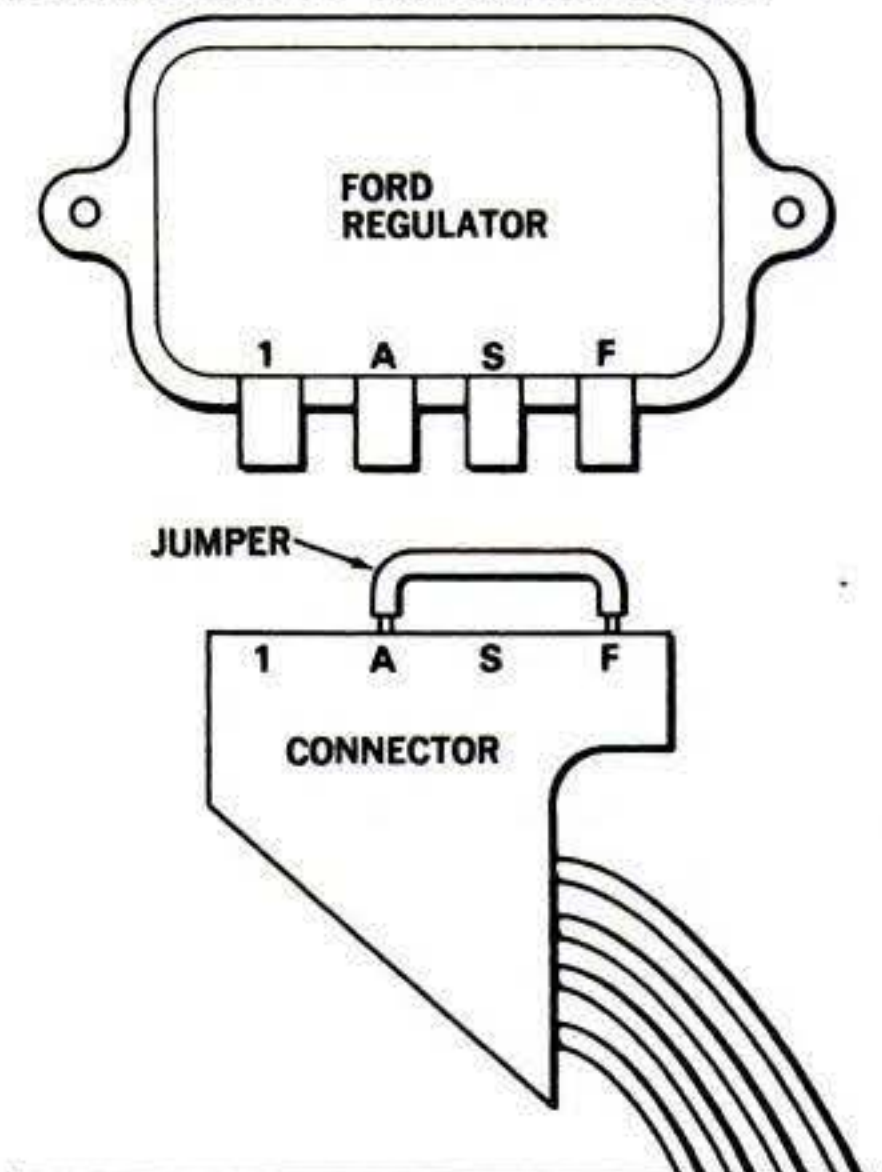

ALCOHOL FUEL!

"MANUAL FOR THE HOME AND FARM PRODUCTION OF ALCOHOL FUELS"

by S. W. Mathewson

"Written by an expert in clear, understandable language, this comprehensive modern manual contains everything you need to know to produce cheap, efficient fuel from almost any agricultural material."

Chapters on: U. S. GOVERNMENT REGULATIONS, FUEL THEORY, MODIFYING ENGINES TO BURN PURE ALCOHOL, GASOHOL, WATER INJECTION, ECONOMIC CONSIDERATIONS, MALTING, MASHING, FERMENTATION, DISTILLATION, and MUCH, MUCH more ... practical, down to earth plans for mashing and fermentation equipment from 55 gallon drums ... plans for an efficient, high volume still and reflux column from common hardware and plumbing items ... PLUS special plans for a continuous feed SOLAR still!

\$12.95 postpaid

J. A. DIAZ PUBLICATIONS
Box 709, Los Banos, Ca. 93635
C.O.D. orders accepted.
Money back if not satisfied.

EQUIPMENT AND TRAINING NO OTHER SCHOOL CAN MATCH!

Explore micro-computers, digital systems and more, with state-of-the-art equipment you build and keep!

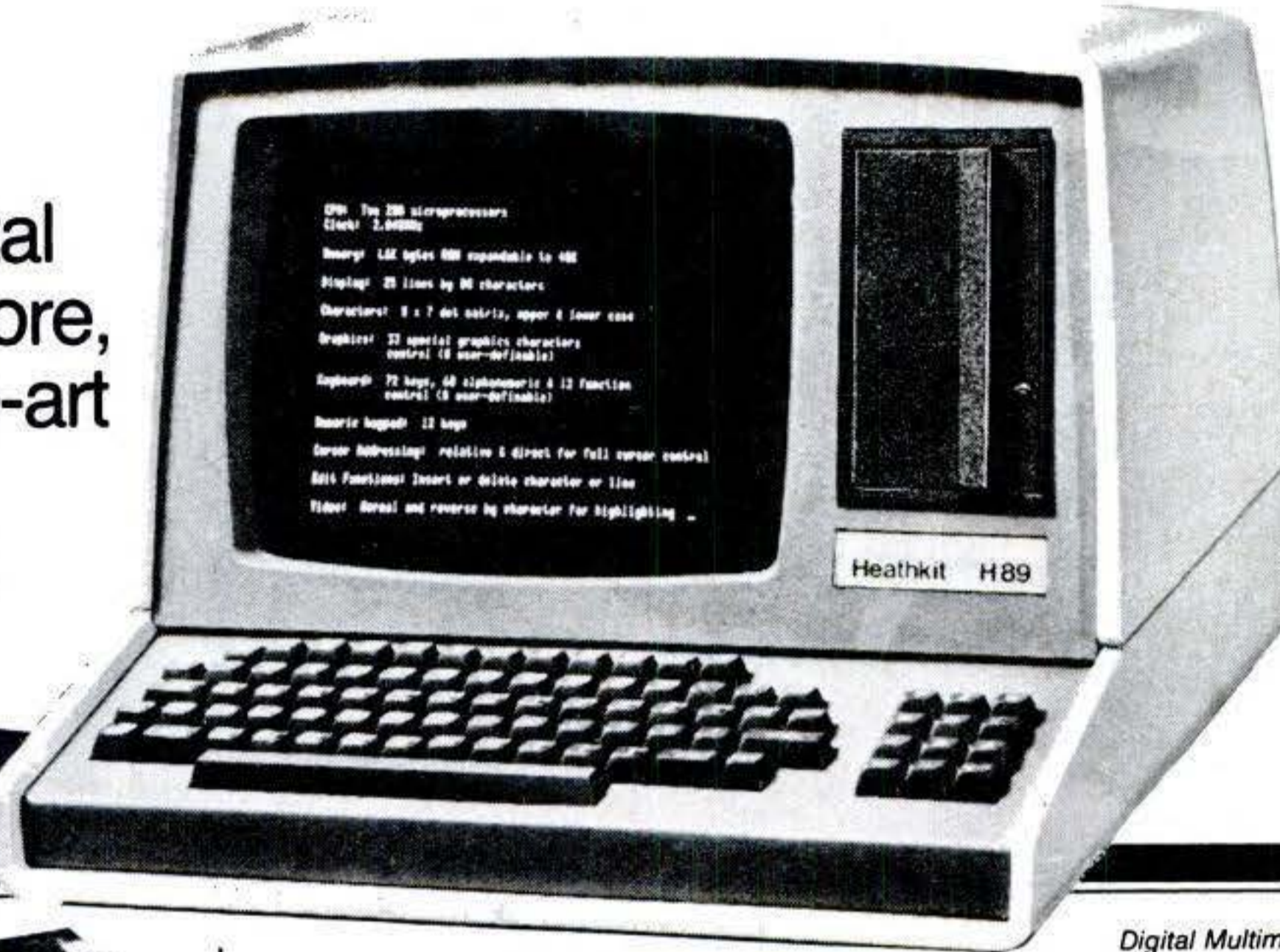

EXCLUSIVE! TRAIN WITH THE NEW H89 NTS/HEATH ALL-IN-ONE MICROCOMPUTER! NTS's Master Course in Microcomputers now includes this remarkable new desk-top computer. Features floppy disk storage, "smart" video terminal (terminal has its own microprocessor, doesn't share one with computer as do most desk models), two Z80 microprocessors, 16K RAM expandable to 48K, professional keyboard.

The new H89 (pictured above) is here and NTS home training has it! An exciting way to explore the very latest in microprocessor technology.

Of course if your interests lie in other areas of electronics, NTS has 14 programs to choose from. And they include the widest array of solid-state and digital equipment ever offered by any home-study school.

Besides the latest in microcomputers, students may work with the NTS/HEATH

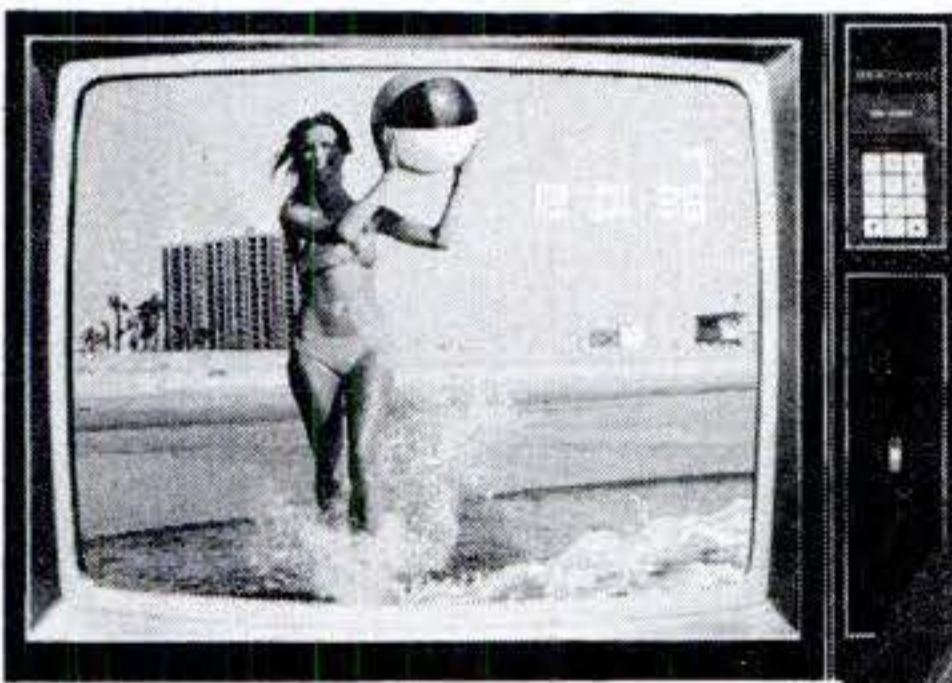

Simulated TV Reception

NTS/Heath Digital Receiver



digital color TV (25" diagonal with optional programming capabilities), digital test equipment, an NTS/HEATH digital stereo receiver (70 watts per channel), plus much more field-type equipment to make your training exciting and relevant.

Each NTS program uses step-by-step lessons and manuals to guide you through experiments, testing, and kit building as you develop skills. The NTS Project Method of training is one of the many reasons students quickly acquire practical know-how.

Digital Multimeter



Our new full color catalog shows you what each course covers, and identifies every unit of equipment included. Send for it today and discover for yourself the *many advantages* of NTS electronics training, and how you can benefit.

NATIONAL TECHNICAL SCHOOLS

TECHNICAL-TRADE TRAINING SINCE 1905
Resident and Home-Study Schools
4000 South Figueroa St., Los Angeles, Calif. 90037

NO OBLIGATION. NO SALESMAN WILL CALL. APPROVED FOR VETERAN TRAINING.

NTS also offers courses in Auto Mechanics, Air Conditioning and Home Appliances. Check card for more information.

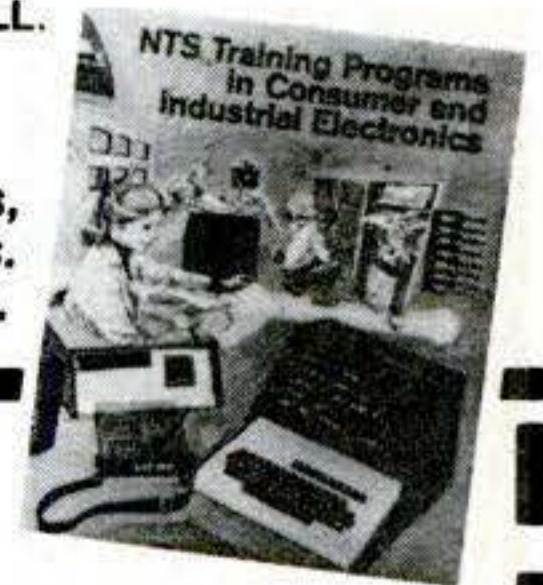

NATIONAL TECHNICAL SCHOOLS

4000 South Figueroa Street, Dept. 202-030
Los Angeles, California 90037

Please rush FREE color catalog on course checked below

- | | |
|---|--|
| <input type="checkbox"/> MicroComputers/MicroProcessors | <input type="checkbox"/> Audio Electronics |
| <input type="checkbox"/> Communications Electronics | <input type="checkbox"/> Auto Mechanics |
| <input type="checkbox"/> Digital Electronics | <input type="checkbox"/> Air Conditioning |
| <input type="checkbox"/> Color TV Servicing | <input type="checkbox"/> Home Appliances |

Name _____ Age _____

Address _____

Apt. _____ City _____

State _____ Zip _____

- Check if interested in G.I. information.
 Check if interested ONLY in classroom training in Los Angeles.

YOU WON'T FIND MANY GRAVELYS IN THE GRAVEYARD.

In an era that finds most Americans expecting their machines to meet with untimely deaths, Gravelys are a pleasant surprise.

Every year we get letters about Gravelys 10, 15, even 25 years old still on the job.

That may surprise you. But it doesn't surprise us.

Because we've never tried to just scrimp and produce our tractors to sell for less.

We always try to make them work better and last longer.

Which is why you'll find something on Gravelys you won't find on other lawn and garden tractors: an all-gear drive direct from the engine through the transmission to the attachments.

So there are no belts to break, slip or wear out.

We also precision-cut the gears, which operate in an

*A Gravely won't wear you out.
It's got instant forward and reverse,
eight speeds for almost any job.*

Our tractor can work for you 12 months a year, with over 20 attachments, from mowing to cultivating to snow removal.



oil bath for less friction and an extended life.

For greater durability, we use cast iron for the transmission housing as well as the pivoting front axle.

For improved efficiency, we bolt the engine directly to the transmission in the rear.

In short, we build our tractor to be out mowing grass long after most machines its age are out pushing up daisies.

For your nearest dealer, check your Yellow Pages.

For the full story, write to Gravely, 0348 Gravely Lane, Clemmons, N.C. 27012.

GRAVELY

Charging systems

[Continued]

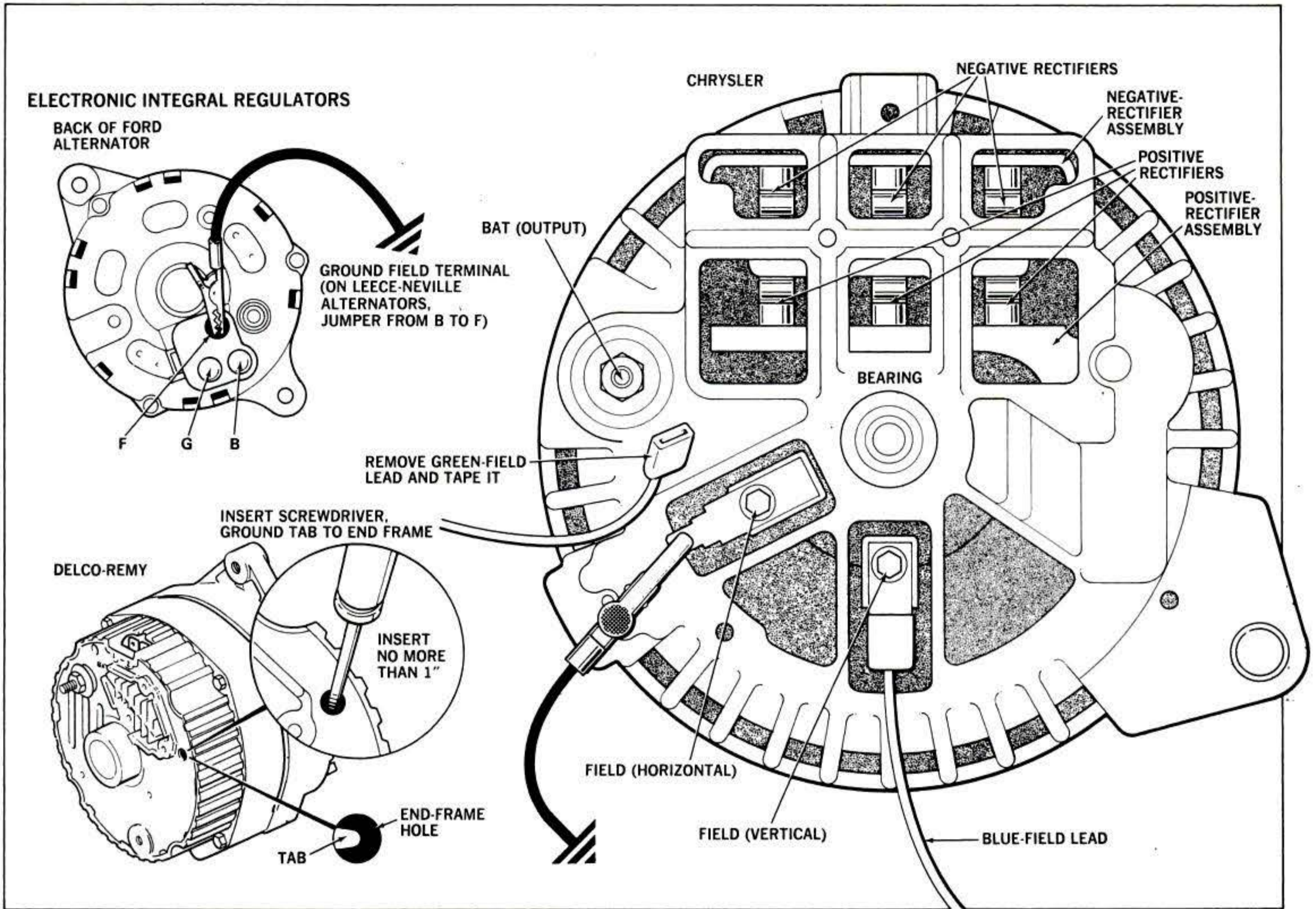

regulator (see drawings). Problems with the electronics are rare. Separate regulators may contain one, two, or three relays. Follow shop-manual directions carefully. A wrong hookup—even for an instant—can blow the alternator.

The GM-Delco-Remy people have made output testing easy by putting a grounding tab behind an opening at the rear end plate of the alternator. Sticking a screw-

driver in the hole and grounding the tab full-fields the alternator. Don't insert the screwdriver more than one inch.

Output results. Start the engine and run it gradually up to charging speed. A voltmeter reading across the battery terminals now should show a 13.8-plus reading if the alternator is charging. This means that the regulator probably is at fault. You're running the alternator without any

controls, so avoid fast engine speeds and long running to keep from overheating the alternator. If you get no voltage above that produced by the battery, the alternator is probably at fault.

After replacing a part, always recheck charging voltage (it doesn't happen often, but sometimes both alternator and regulator fail. A new alternator still won't do the job if the regulator is bad as well).

Amp-testing is easiest using a battery-post adapter. Some BPA's have a built-in quarter-ohm resistance to simulate a fully charged battery when making regulator adjustments. It won't affect the output test.

With the voltmeter and ammeter connected to the battery-post adapter as shown, you're reading for a volts-and-amps alternator-output test. The jumper should be connected as before, so the alternator output is unregulated. Unregulated output amperage—with a load on the system—should reach within 10 percent of the alternator's amperage capacity (see owner manual or service-manual specs). If it cannot, the alternator may be beginning to weaken (the brushes perhaps?). For example, an alternator rated at 55 amperes should show about a 50-amp charge and perhaps 13.8 or more charging volts. If it does, you can be sure

Continued

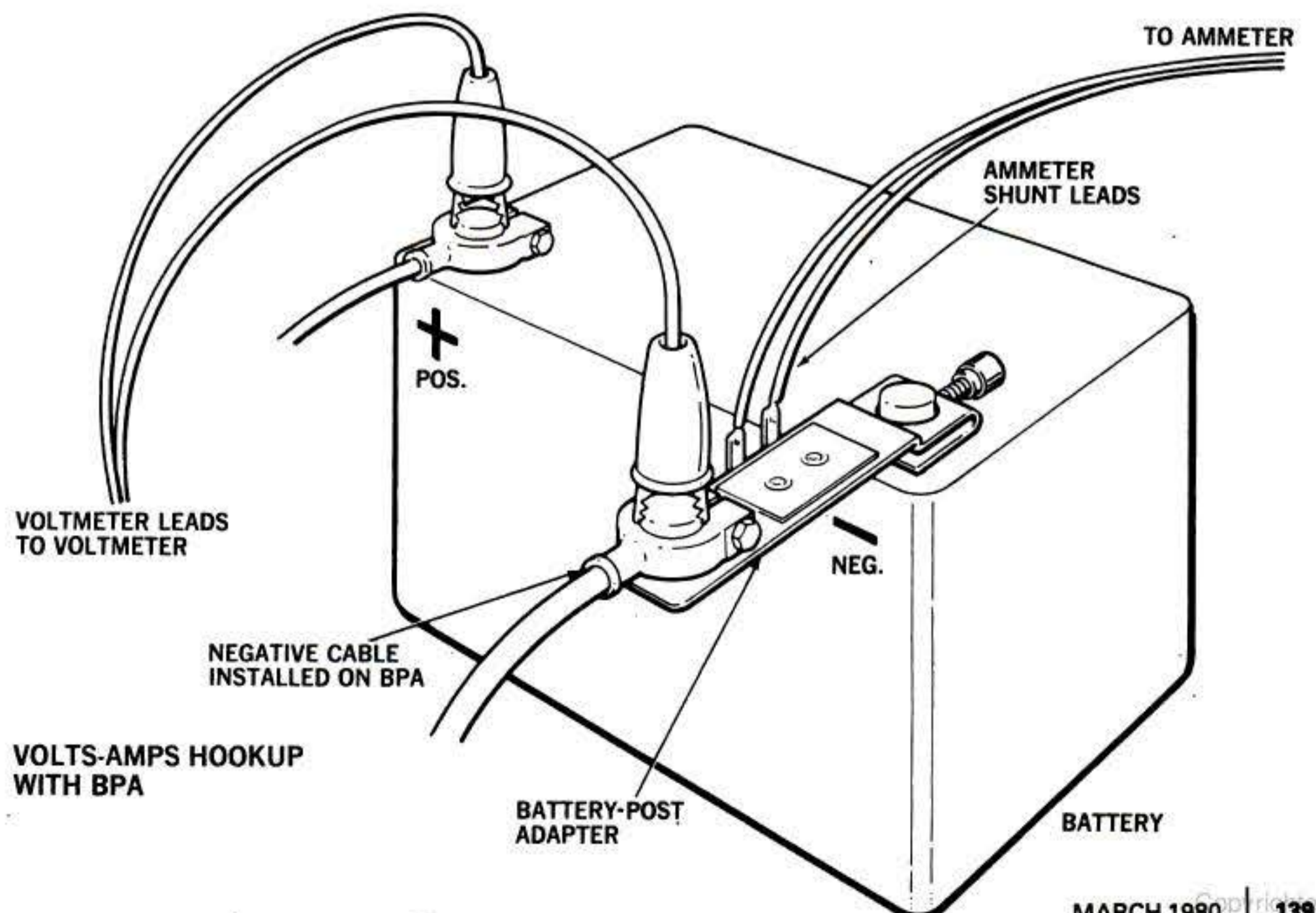

TO COMPLETE
YOUR WORKSHOP
**ATLAS
BANDSAW**
IT'S CONVERTIBLE

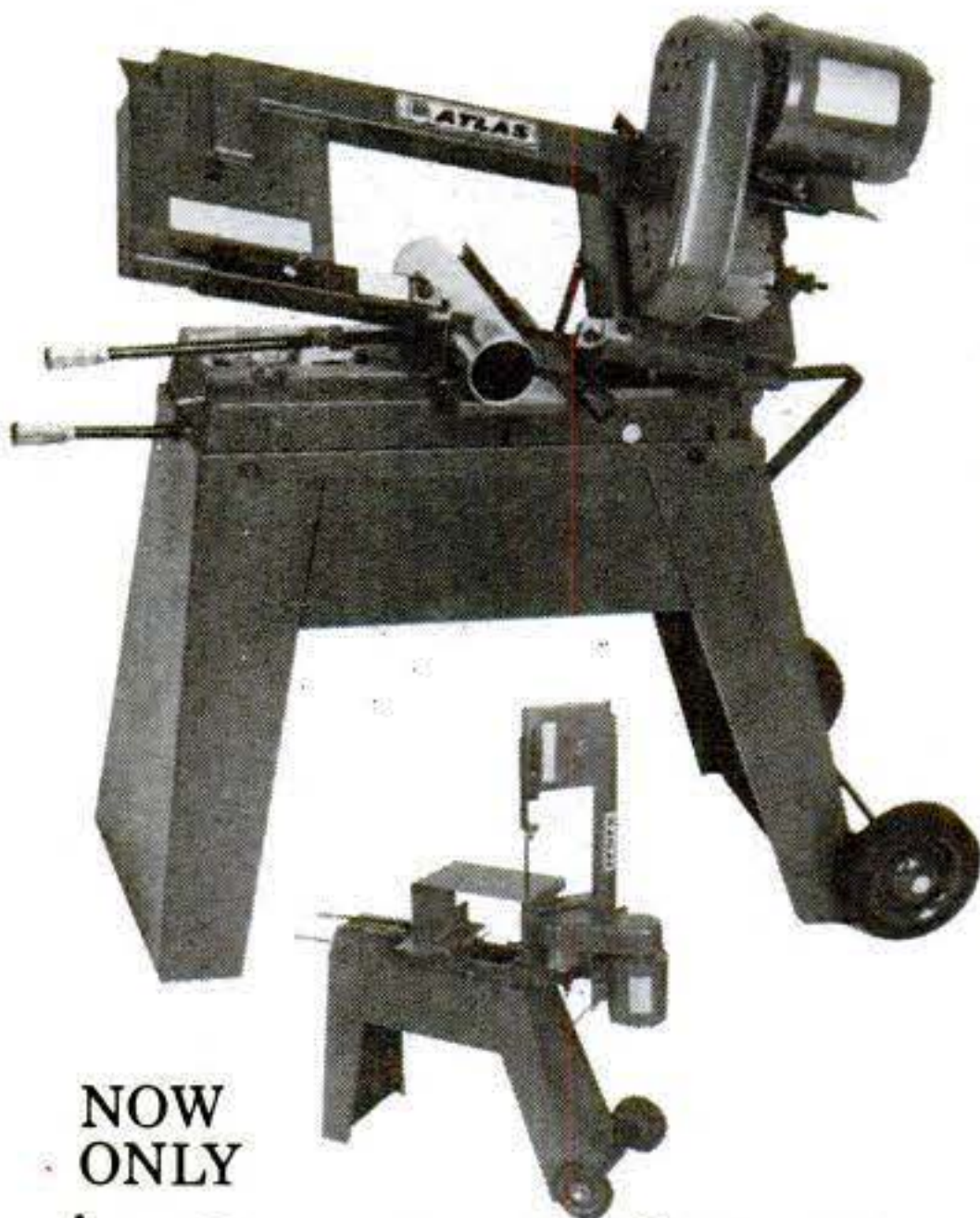

NOW
ONLY

\$235⁰⁰

plus \$30 handling and shipping

The Atlas Band Saw • Handles cut-off operations in a wide range of metals – from steel and iron, to aluminum, brass and copper • Comes complete with $\frac{1}{3}$ hp, 1725 rpm motor • Takes any shape stock – bar, flat, square, hex, tubing structural shapes, and cuts it at any angle from 90° to 45° . Max. capacity is 4" x 6" • 3-speed V-belt and worm gear drive offers speeds of 90, 155, 250 rpm • Swiveling rapid approach/release type vise allows fast set ups. Set desired cut, and spring-control feeds blade at proper speed for smooth, fast cuts • Has stock stop for repeat cutting • *Converts to vertical position* for contouring, notching, slitting, and other operations in metal or wood. Length 41", height 37", width $16\frac{1}{2}$ ". Extends to 43" length, $47\frac{3}{4}$ " height in vertical position.

ATLAS BANDSAW

Mail To: ATLAS PRESS COMPANY, Dept. 185
2019 N. Pitcher, Kalamazoo, MI 49007

Please send me the Atlas Band Saw (Model 4359).
Enclosed is my check or money order for \$265.00.
(Includes shipping and handling) or charge my order to:

VISA Master Charge

Acct. # _____ Exp. Date _____

Name _____

Address _____

City/State/Zip _____

Send FREE Atlas Power and Hand Tool Catalog.

Michigan residents add 4% sales tax.

Available continental U.S.A. only.

Price subject to change without notice.

Charging systems

[Continued]

that any no-charge or low-charge trouble will be found elsewhere. The alternator and its diodes are okay.

A professional mechanic would put a load on the system with a variable carbon-pile rheostat (too expensive for the average do-it-yourselfer). Without the carbon pile, you can put a load on the system that will give you a ball-park reading. Crank the engine for about 15 seconds with the ignition system disabled so the car won't start. Then start the car and immediately bring the engine speed up to about 2500 rpm and quickly read the ammeter—because the maximum reading will only show for several seconds and then drop off.

In any case, a thorough visual check of the charging system's insulated and ground-circuit components should always be made before condemning either the alternator or regulator. These circuits alone can cause a no-charge or low-charge condition.

Regulated charging tests. The hookup is the same as in the drawing on page 139, except that the full-fielding jumper lead is not used this time. Everything on the car should be connected as it would be for driving, except for the use of a battery-post adapter.

Charging voltage and amperage should agree with the minimum and maximum specs for your vehicle. Voltage specs vary from the low 13's to the 15's (battery should be fully charged when checking for regulator setting). A typical minimum is 13.5 volts; a typical maximum, 15.3.

To determine the maximum amperage the regulated charging system can deliver, you'll have to discharge the battery as you did earlier. Then start the car, immediately rev it to about 2500 rpm, and take the reading before the maximum charging reading tapers off. Regulated charging amps should reach at least 50 percent of the car's alternator rating. It doesn't hurt to have the headlights and accessories on.

More on typical output-test jumper connections

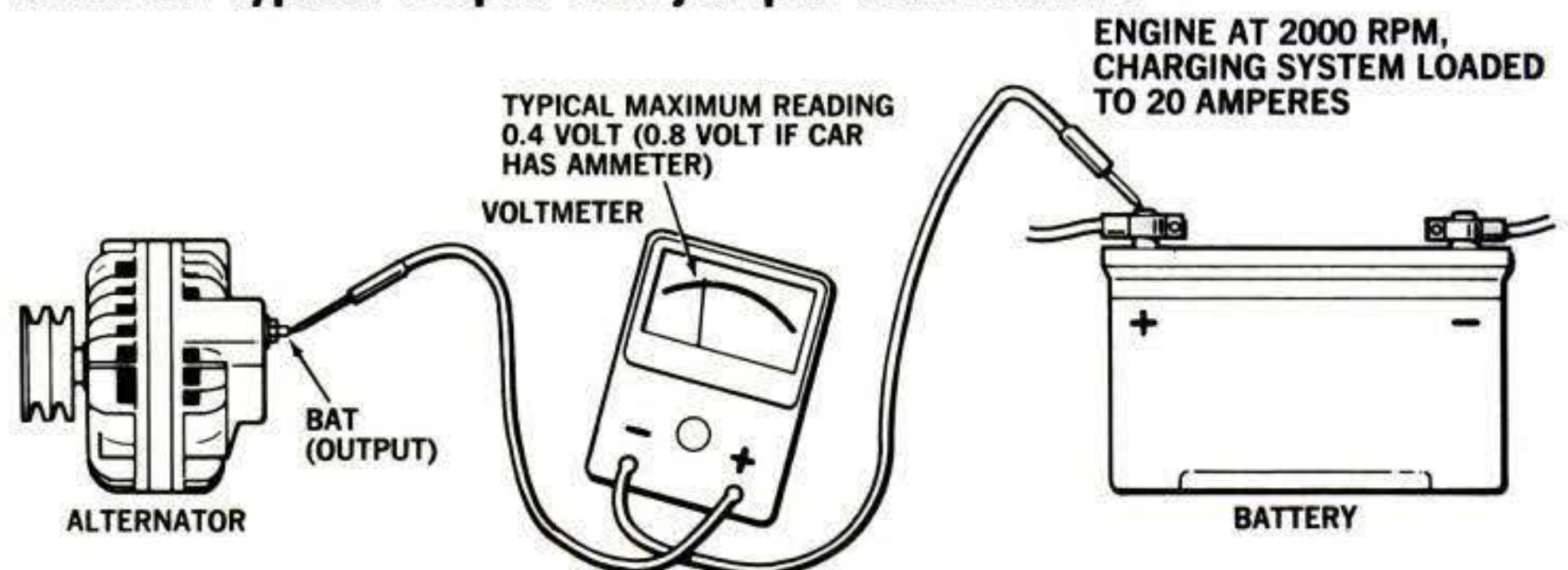

VOLTAGE DROP—INSULATED CHARGING CIRCUIT

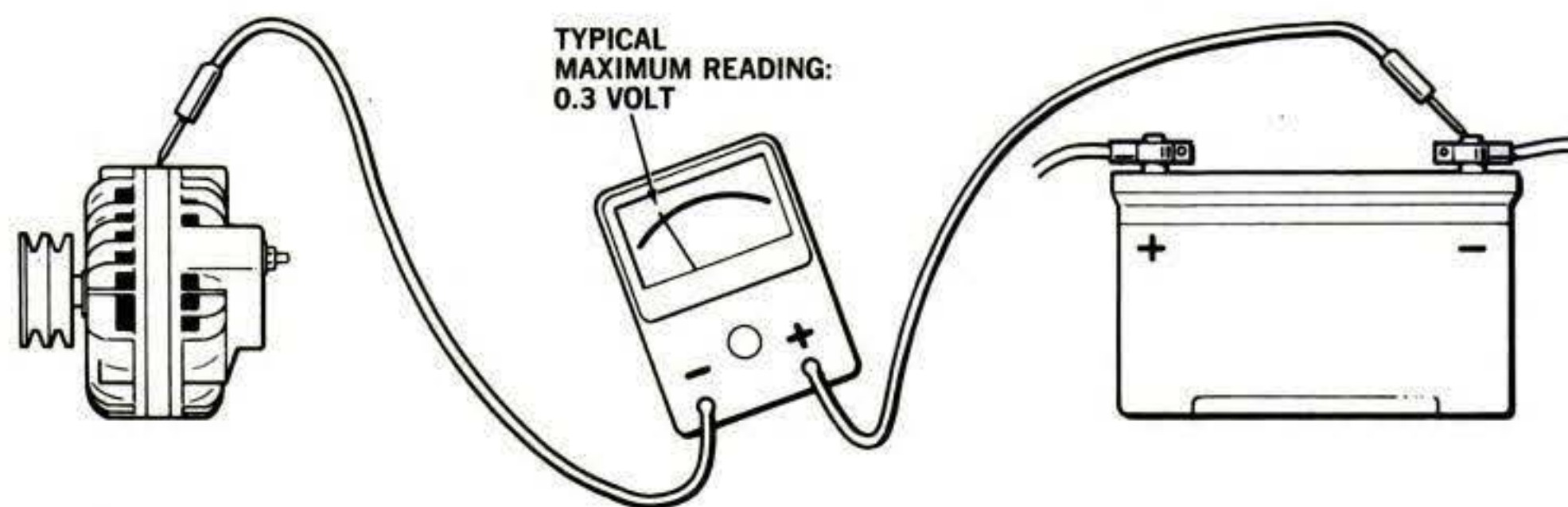

VOLTAGE DROP—GROUND CHARGING CIRCUIT

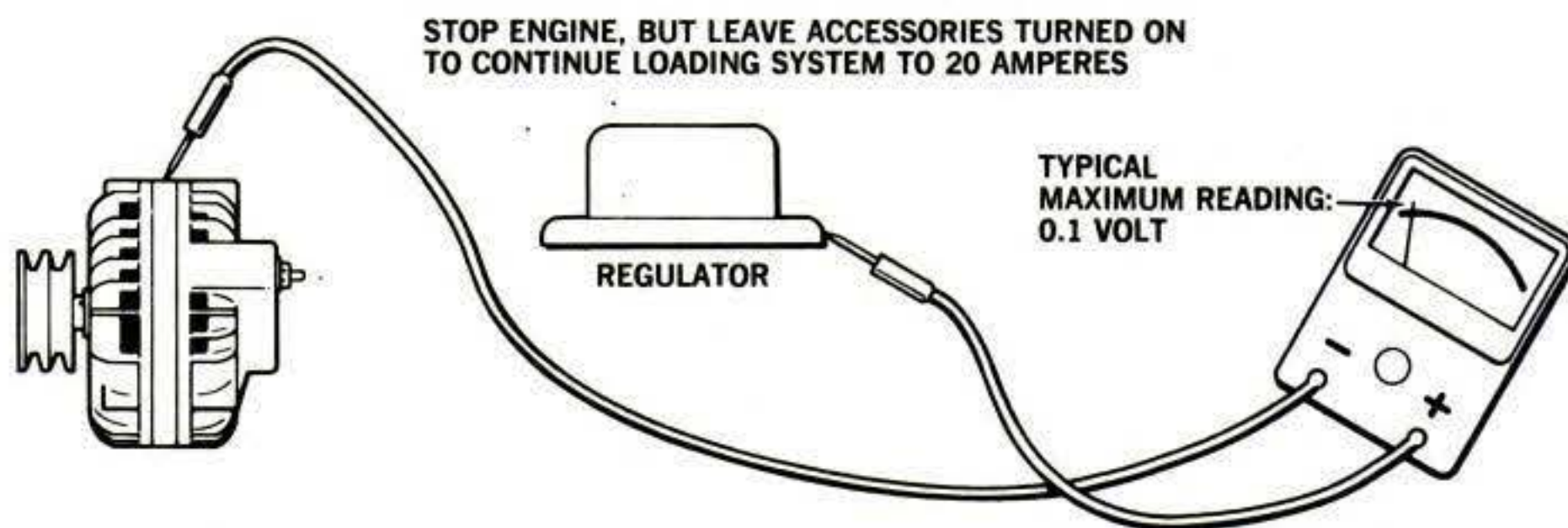

VOLTAGE DROP—ENTIRE GROUND CIRCUIT

Voltage-drop tests show whether excessive resistance is present. Sometimes poor connections—insulated or ground cir-

cuit—cause charging problems. With a low-reading voltmeter it takes only seconds to check for this. These drawings

Continued

Copyrighted material

E=mc³

Slips like this are the kind you're not likely to make with the Sharp 5100, because you see the actual form of the equation instead of an assembly code.

The more you think about Sharp's Scientific Calculator, the more it departs—exponentially—from all your existing ideas about programmable calculators.

The 5100 is the first programmable calculator in which algebraic equations can be entered directly, using algebraic symbols, trigonometric functions, logarithmic, exponential, others.

The 5100 is also the only hand held to give you a complete display of the equation: you see 24 characters at a time in a dot-matrix display that rolls right or left to accommodate one or more formulas up to 80 steps. It also has a computer-like cursor which you can move to any part of the display to edit or correct the equation you've entered.

Where programmable calculators display one *program step* at a time (and which then has to be decoded), the 5100 serves up the actual equation in its entirety.

The rest of the 5100's technology is on the same high level. There are ten registers for variables in which numerical values can also be stored. Values can be quickly changed for successive approximations. Anything entered can be played back instantly. All formulas and figures remain in memory with the power off (it's like carrying your engineering notebook around with you). It has so many uses an entire book has already been written about it.*

Sharp has a complete line of highly useful scientifics, starting at \$16.95†. But if you want nothing less than the leading edge today in scientific calculators, buy the 5100 (under \$100.00).

And that's not much to avoid the consequences of $E = mc^3$.

*Advanced Analysis with the Sharp 5100 Scientific Calculator by J.M. Smith. Published by John Wiley.

† Suggested Retail Price

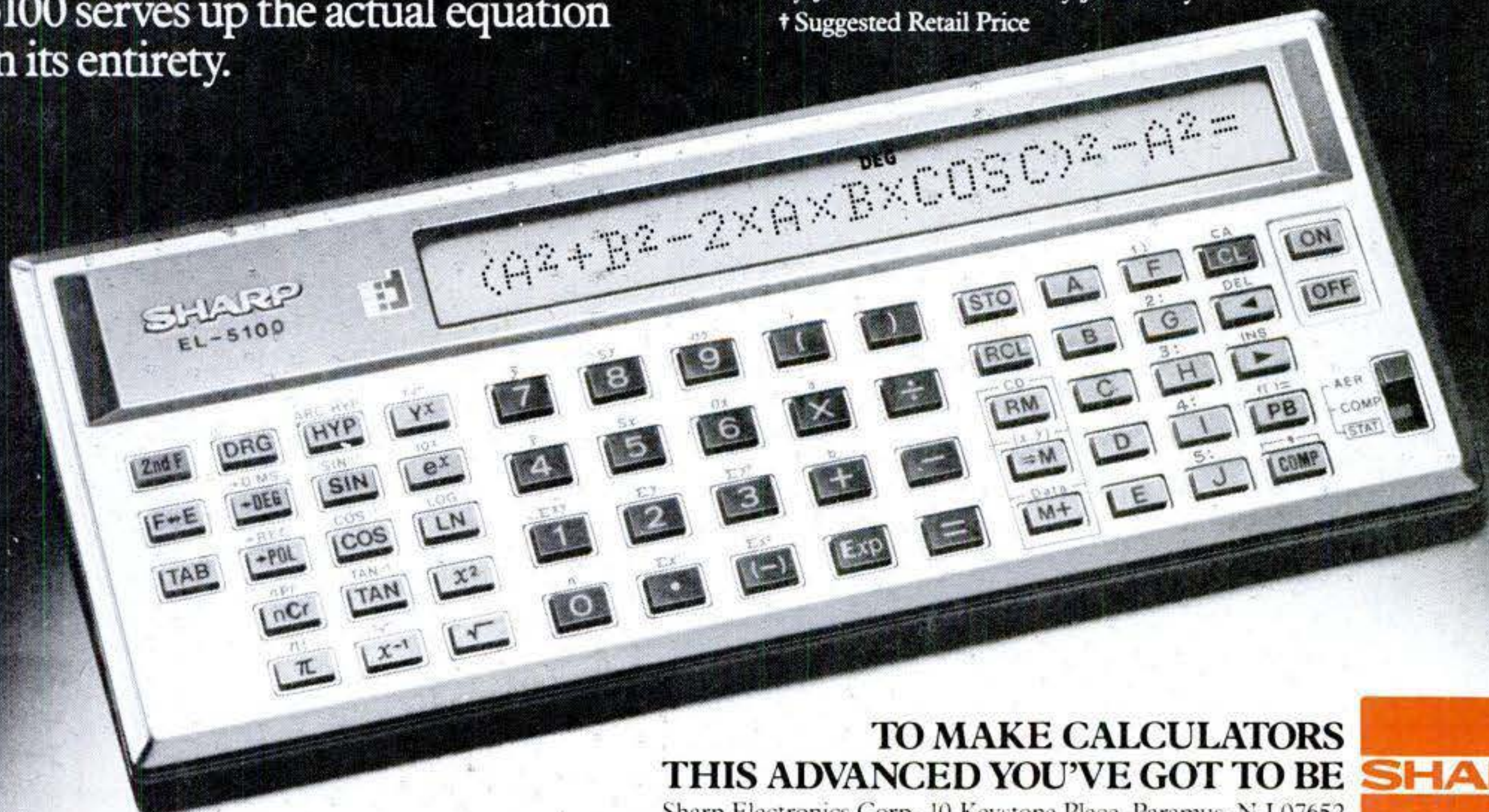

**TO MAKE CALCULATORS
THIS ADVANCED YOU'VE GOT TO BE**
Sharp Electronics Corp., 10 Keystone Place, Paramus, N.J. 07652



Enjoy the taste of country fresh Salem.



Country fresh menthol.
Mild, smooth and refreshing.
Enjoy smoking again.

Also available in 100's.

KING: 16 mg. "tar", 1.1 mg. nicotine, BOX: 18 mg. "tar", 1.2 mg. nicotine,
100's: 19 mg. "tar", 1.3 mg. nicotine, av. per cigarette, FTC Report MAY '78.

Warning: The Surgeon General Has Determined
That Cigarette Smoking Is Dangerous to Your Health.

Charging systems

[Continued]

show the insulated and ground-circuit voltage-drop hookups. These are made on a *loaded* charging circuit to check resistance. The system must be charging when making two of them.

To load the charging system for the tests, turn the headlights on high beam and the heater blower on full to bring the charging rate to about 20 amperes. Run the engine up to charging speed by turning the idle-speed screw clockwise. Put the voltage selector on its lowest setting, and make the three tests illustrated in the drawing. (Reverse the hookups for a positive-ground electrical system.)

Too much voltage drop in any of the three tests indicates high resistance, calling for a careful visual examination. Reset the engine's idle before closing the hood. If you cannot correct for too much resistance between an alternator and the car frame otherwise, install a No. 10 copper grounding wire permanently between the two.

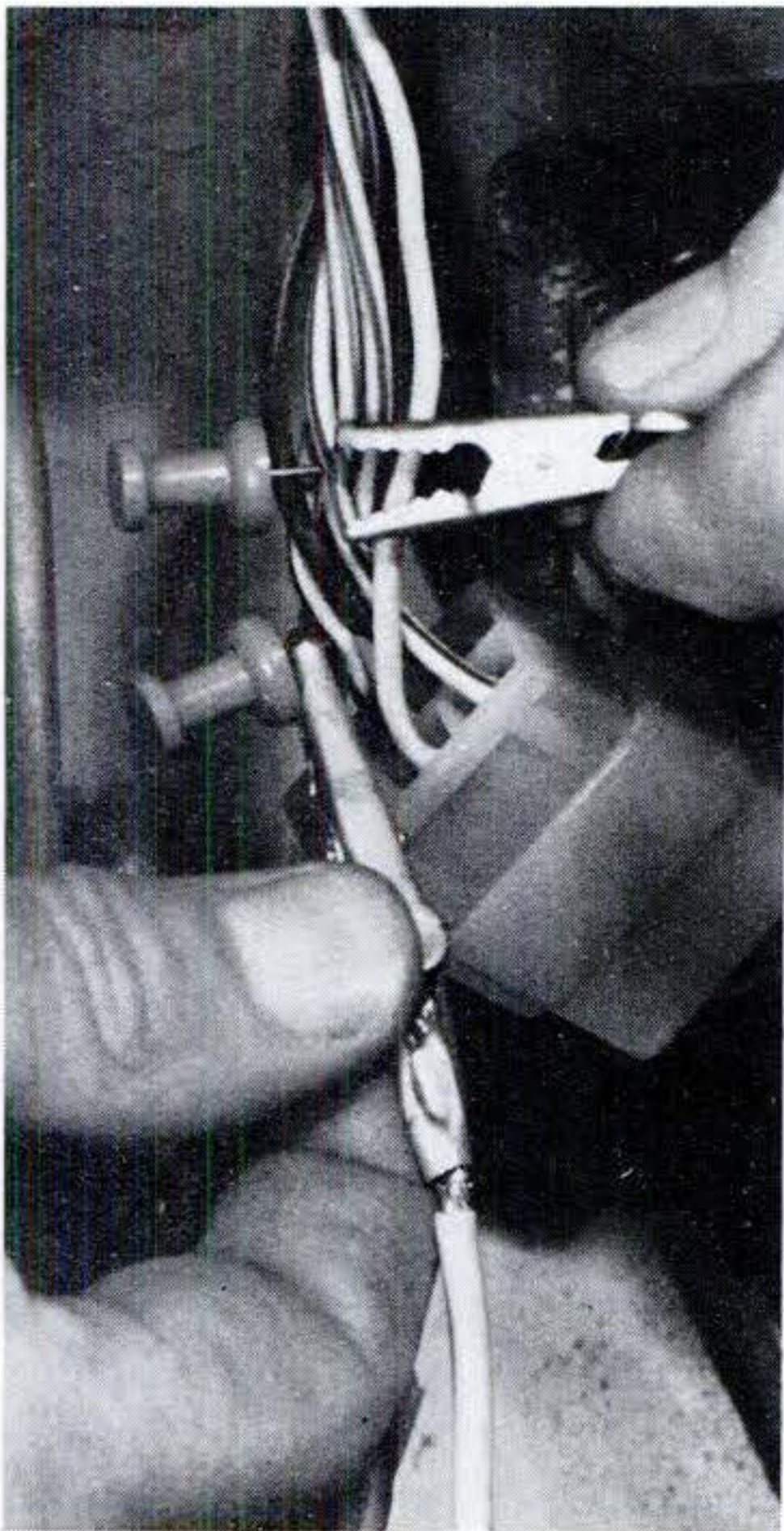

Tapping into insulated circuit wiring for charging tests is aided by pins. Pushed through the insulation into the wire (watch your fingers), pins let tester prods and clips read out what's happening.

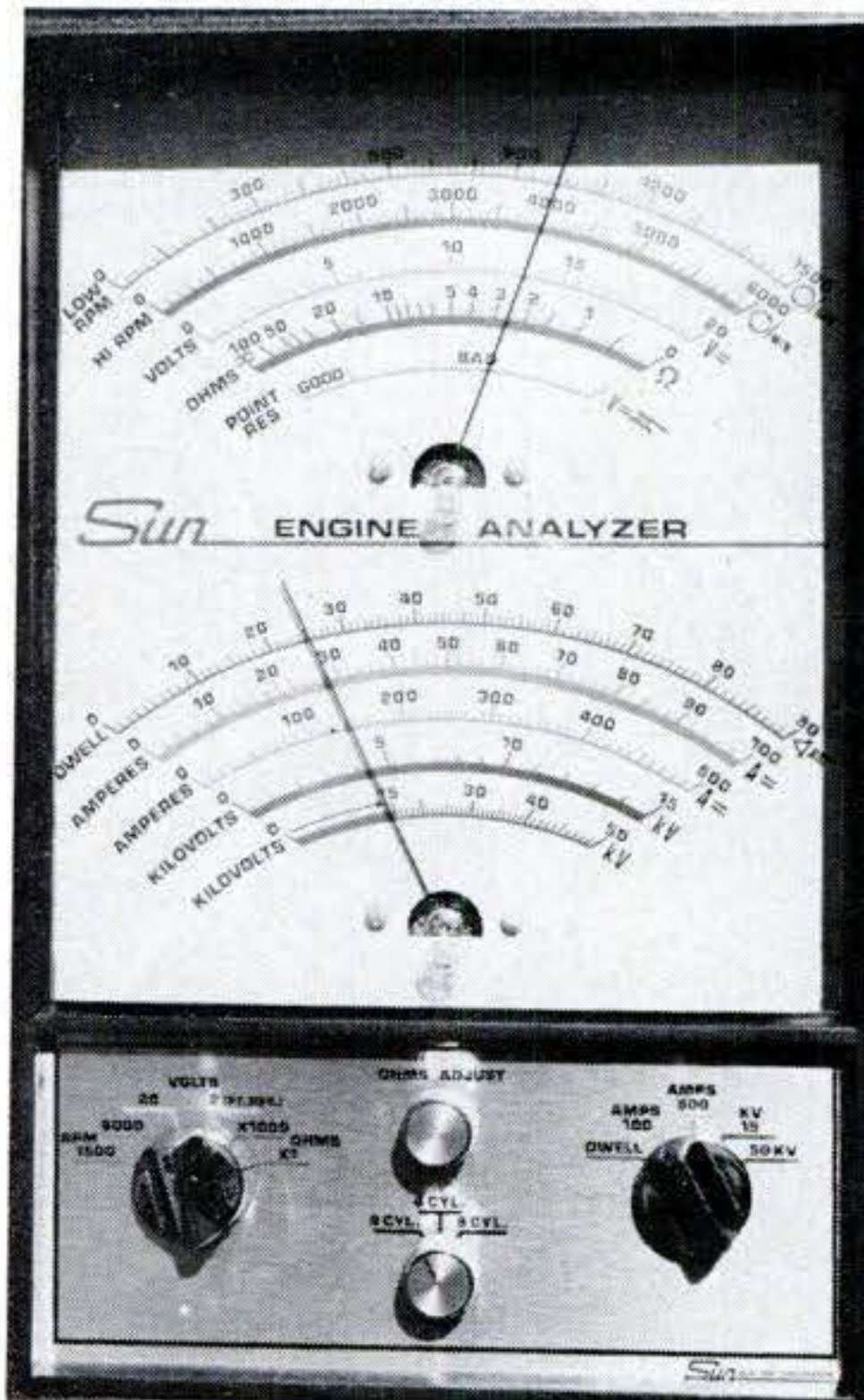

Dual gauge voltmeter/ammeter lets you read volts and amps simultaneously.

Symptoms and possible causes

Charging rate too low or zero—hard-starting; battery tests less than 1.230 or goes dead; headlights weak:

- Alternator faulty. Repair or replace.
- Regulator faulty. Replace.
- Regulator's voltage limiter setting too low. Increase it, or replace regulator.
- Loose or worn alternator drive belt. Tighten or replace.
- High resistance in insulated or ground circuits (most systems). Correct.
- Undersized alternator for the load.
- Open field circuit. Test field wire between regulator and alternator for continuity. Install new field wire.
- Defective battery. Replace.

Charging rate too high—battery needs water more than every two or three months (if not a low-maintenance or maintenance-free type); bulbs burn out; fuses blow; headlights brighten greatly when charging:

- Regulator's voltage limiter set too high. Reduce it, or replace regulator.
- High resistance in parts of regulator's ground circuit. Clean and tighten regulator mount.
- Shorted or grounded field wire (some systems). Test continuity. Repair.
- Defective battery. Replace.

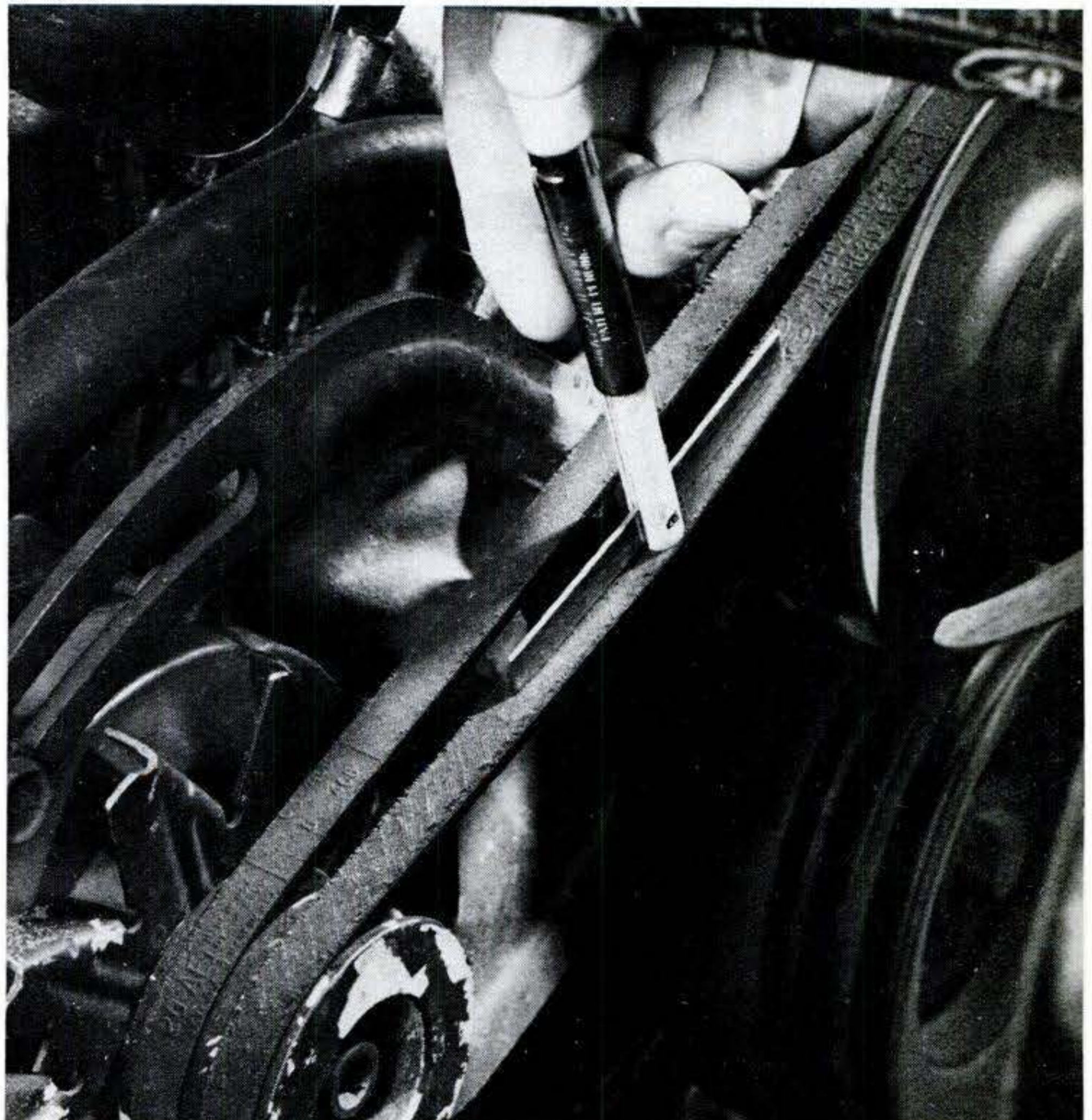

A no- or low-charging-rate problem can be as easy to fix as tightening or replacing the alternator drive belt. Most accurate method of adjusting it is with a belt-tension tester (shown here), using car manu-

facturer's strand-tension spec. Or you can use the simpler rule of thumb of 1/2-in. up-and-down play at midpoint under about 20 lbs. of pressure. When tightening, pry on alternator end frames, not body.

TAKING CARE OF YOUR CAR

Got a useful car tip? Send it (with Social Security No.) to Car Care, Popular Science, 380 Madison Ave., New York, N.Y. 10017. We'll pay you \$25 if we use it. If two or more readers send in the same usable tip, the one with the earliest postmark will be chosen. Sorry, but tips can't be returned.

By RAY HILL

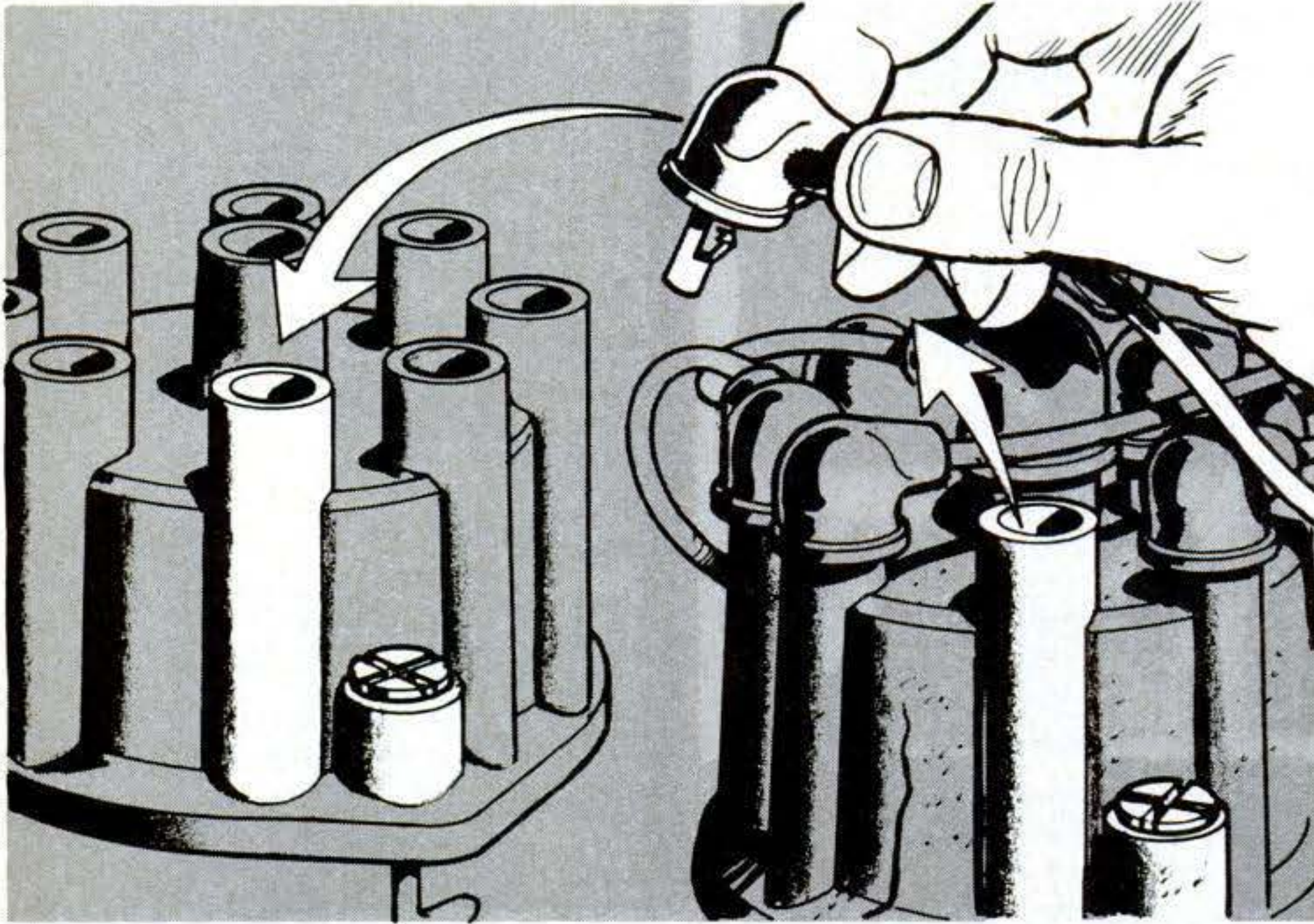

Replacing distributor cap without getting wires crossed

The easiest way to install a new distributor cap without getting the spark plug wires mixed is to place the new distributor cap next to the old one so that the hold-down clips (or screws) and the locating notch or protrusion on the bottom are in the same position on both caps. Then transfer the spark-plug wires from the old

cap to the new one—working in a clockwise direction, one wire at a time. Be sure the first wire you transfer goes in the tower of the new cap in the same location as on the old cap. Then all the wires will be attached in the correct order. You can transfer the coil wire last. Be sure that each wire is pushed completely in.



Precise hacksaw cut

Need to shorten a piece of round stock or sheet metal an exact amount? Mark the location with a few back-and-forth movements of a file. Then place the hacksaw blade in the tiny channel created by the file and begin your cut. This will prevent the hacksaw blade from wandering until the teeth get a good bite.

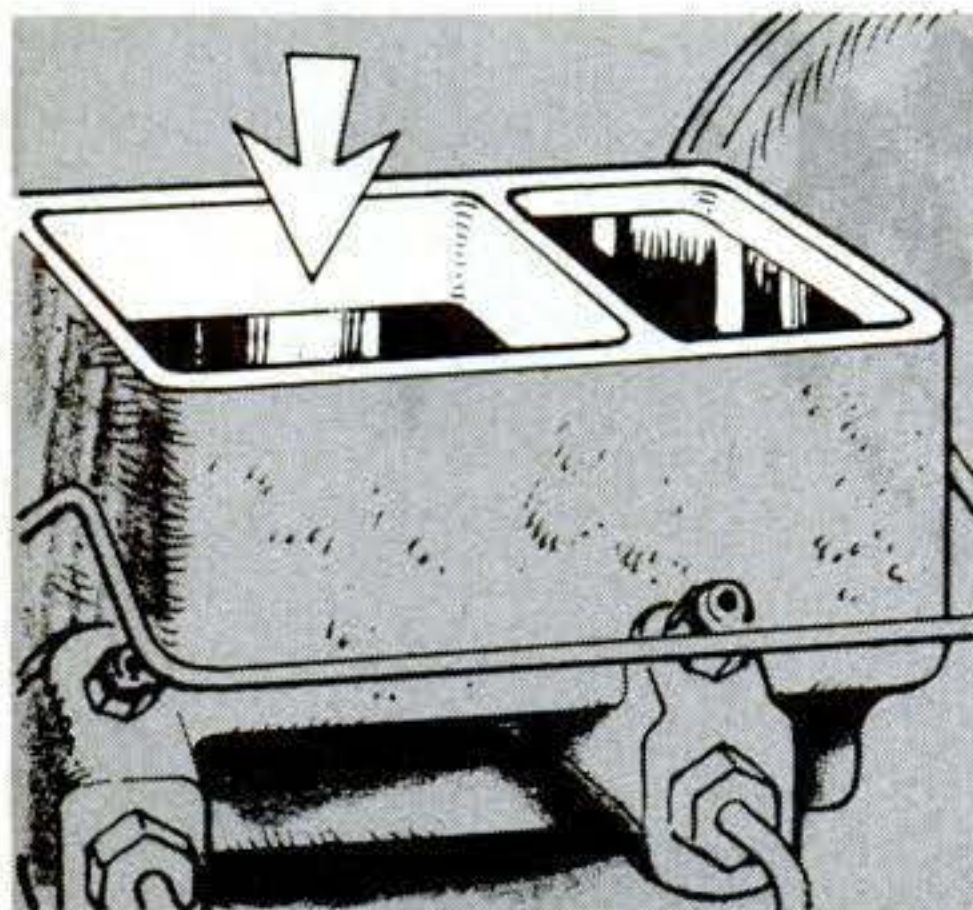

Checking the master cylinder

If your car has disc brakes in front and drum brakes in the rear, and if the reservoir for the front brakes is low but the one for the rear is full (and there are no leaks in the system), there's probably nothing wrong—except that the front pads are worn. The reservoir for the front brakes is usually the larger of the two reservoirs. Top off the reservoir. And check front disc pads and rear shoes to make sure they're not worn excessively. Replace them if you find that they are.

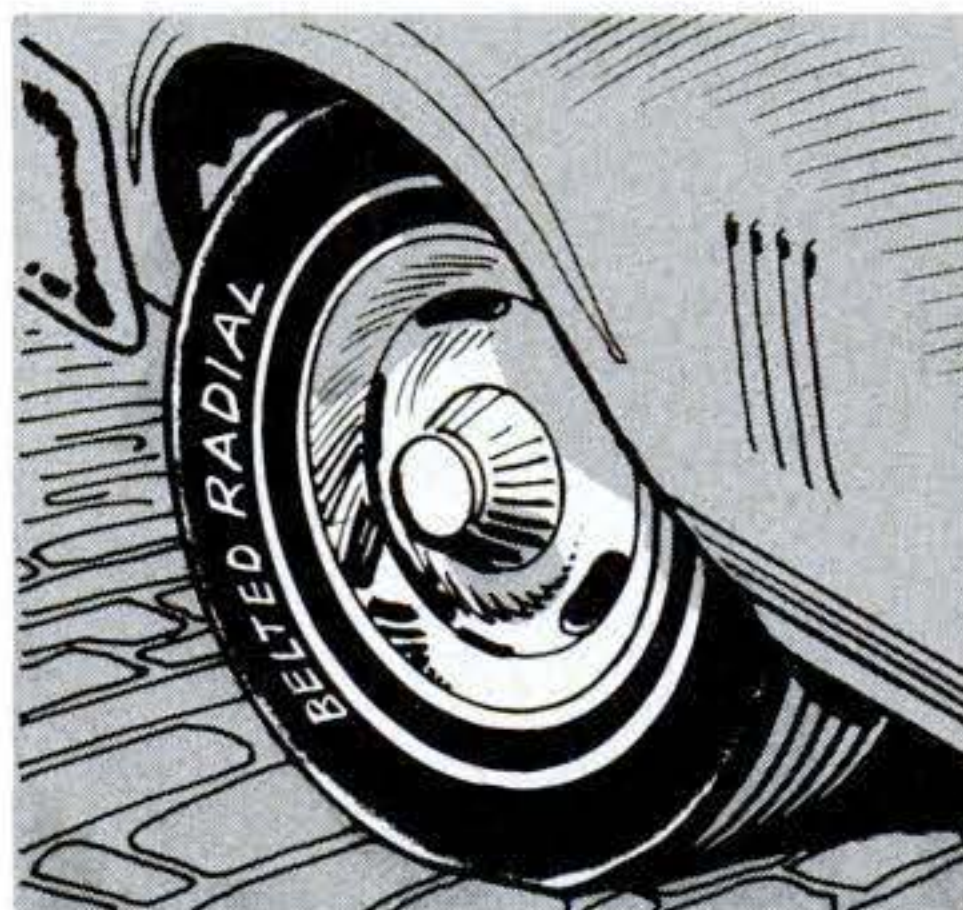

On front-drives and radials

Do you have a front-wheel-drive car with radial tires? Goodyear recommends that you do not rotate them as is common on cars that are rear-wheel driven. "Unless excessive irregular wear patterns develop on front or rear tires, rotation can cost you tread life and generally isn't recommended," says Joseph Musteric, manager of radial auto- and race-tire engineering at Goodyear. By not rotating the tires, the rear tires will probably last the life of the car, according to Goodyear.

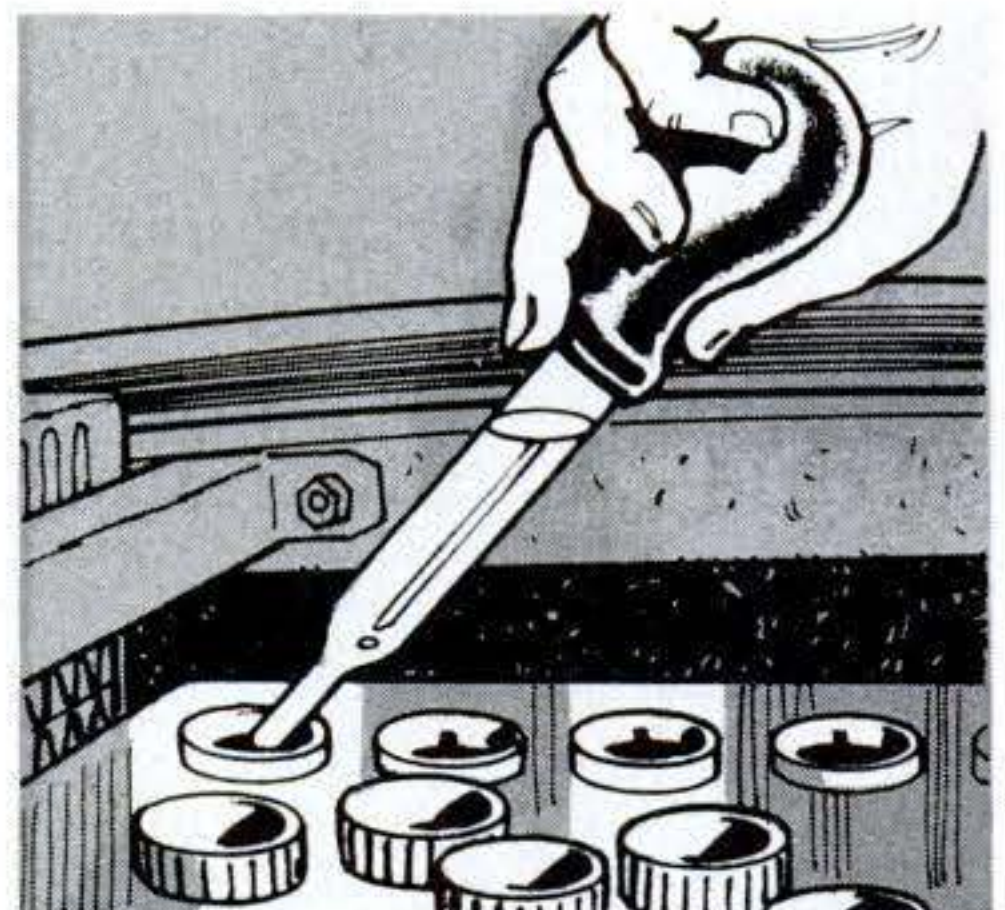

Kitchen baster handy

An easy way to add fluid to hard-to-reach reservoirs (battery, master cylinder, transmission, power-steering) is with an inexpensive bulb baster. Suck in fluid from the container, then squeeze out as needed into the fill hole. To keep fluid from dripping from the baster, hold your finger over the tip until it's over the fill hole. Don't use the same baster for different reservoirs; i.e., you don't want brake fluid mixing with transmission fluid. Mark the basters so you don't mix them up.

A creation of elegance



Classic Motor Carriages, world's largest manufacturer of Replicar assemblies, provides the project...and anyone of you can easily achieve the elegant result.

You convert your Ford or VW component into this dazzling replica of the famed 1929 Mercedes SSK...the Gazelle. Turning a wrench, tightening a bolt, lifting a superbly handcrafted fender into place...

Day-by-day, the transformation takes beautiful shape you have completed "The Gazelle." And then it's the pride of achievement that bursts into motion...and you are driving with a satisfaction rarely experienced, your creation of elegance is completed.

Then you believe how easy it really was...a creation you assembled with just ordinary tools and no special mechanical skills. The Gazelle, yours because you made it...yours to enjoy day and night...and economical, too, with 32 mpg.

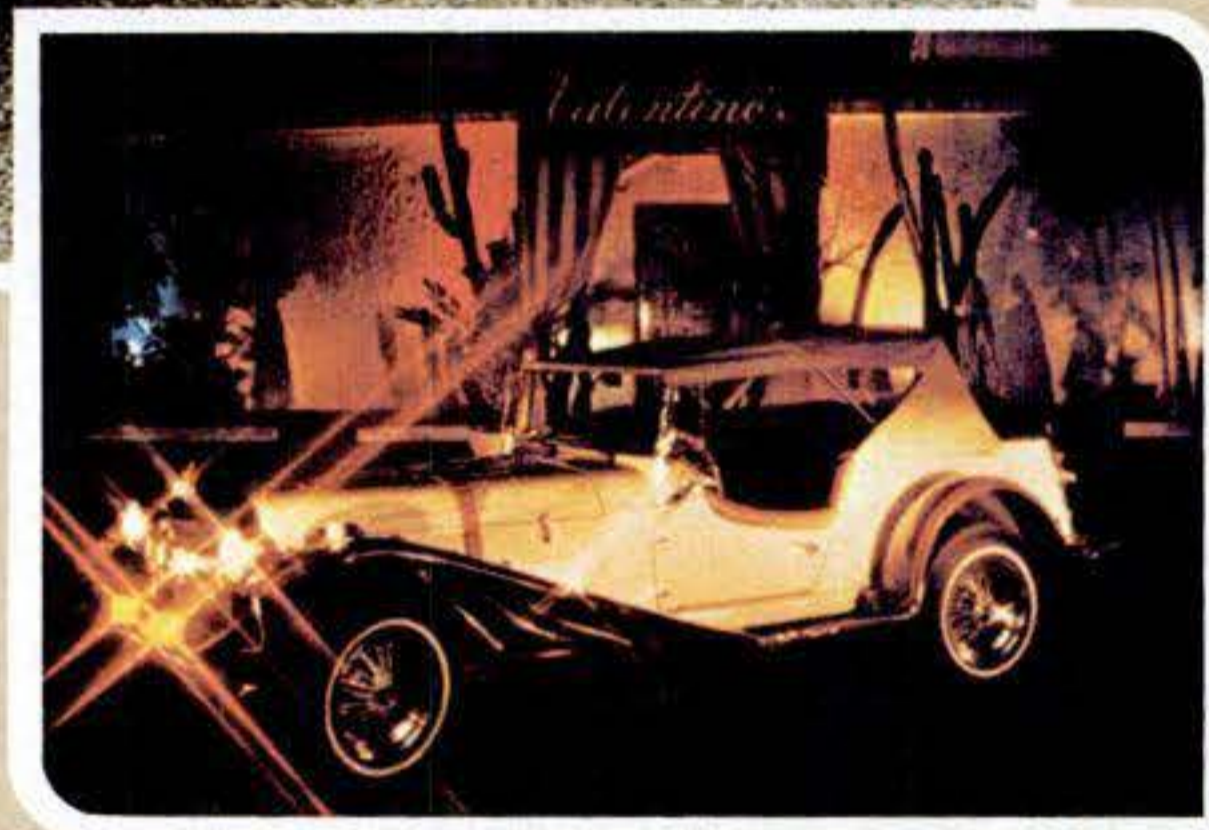

REPRODUCTION OF ACTUAL GAZELLE POSTER
ORDER YOURS TODAY! SEE COUPON BELOW

Classic Motor Carriages, Inc.

200 PS3 South Federal Highway, Hallandale, FL 33009

Telex: Replicar HALA 519225/Tel: (305) 456-1500

Name _____

Address _____

City _____ State _____ Zip _____

Home phone _____ Office phone _____

Enclosed is \$3.00 for your 20 page color catalog, full information & consumers buying guide.

Enclosed is \$20.00 for assembly manual plus 20 page catalog; full information & consumers buying guide. Ford VW

For even more information, be sure to send for our manual describing the easy step by step assembly of the Gazelle as well as many interesting facts and information. The cost of the manual will be credited to any purchase.

Enclosed is \$5.00 for full color brochure and all pertinent information for the handcrafted, fully-finished Gazelle.

Enclosed is \$5.00 for 24" x 36" full color Gazelle poster.

Please charge my: Master Charge _____

Bank Americard/Visa _____

American Express _____ Exp. Date _____

Factories and Sales Offices throughout the World.

See our airport display at: Atlanta, Burbank, Chicago, Miami, Minneapolis/St. Paul, New Orleans, Denver, Philadelphia, Seattle, Baltimore/Wash., Logan Int., Boston, Kennedy, N.Y., Amarillo, Tex. & Love Field, Dallas, Tex., Dallas/Ft. Worth.

GAZELLE OWNERS REPORT GAS MILEAGE OF 27-32 MILES PER GALLON.

➤ Mail this coupon today to begin one of the most exciting projects ever.

"SAY, SMOKEY—"

A clinic on cars by Smokey Yunick, America's most famous mechanic

Antifreeze okay in the oil?

I have a 1974 Buick eight-cylinder 455. At 59,000 miles I had the oil changed and sent a sample of the oil to Gulf Motorcheck. The report indicated everything was near normal except for a high concentration of antifreeze in the oil. My service man checked and told me it was not serious and not to worry. At 60,500 miles I had the oil drained and sent in another sample. Same report. Now I am beginning to wonder just how dangerous the condition really is.

Others have told me this is not unusual. Is it? Until I get your opinion I am changing the oil every 1000 miles.

There's no reason for any antifreeze in the oil. It's bad news. Find the water leak. Expect to find it in head gaskets or at the ends of the intake-manifold gaskets.

Wants to swap engines

I have a 1974 Buick Electra with a 455 gas-hog engine. It is a very nice car to drive, so I want to keep it. The engine has over 90,000 miles and is due for a major overhaul. Can I install one of GM's 350 engines in this body? I don't need all of that 455 power and I very seldom drive 55 mph.

Frank Ziegler, Cincinnati, Ohio

You can put one of Buick's smaller eights in very easily. But everything has to be changed. It's gonna be pretty expensive. I doubt that you'll get enough extra mileage to recover your investment.

Power options

I have a 1978 six-cylinder Dodge Sportman B200 Maxiwagon with a two-barrel carb, a three-speed transmission, and no catalytic converter. This combination gives great mileage on the highway, as high as 22 mpg. But it lacks power for passing, pulling long hills, and bucking headwinds. I have been thinking of several remedies:

(1) Turbocharging with a mild amount of boost. Can a happy medium between acceptable performance and reliability/durability be reached without extensive engine modifications? Also, who makes a good turbo kit that can be installed by a DIY'er?

(2) Headers. I realize they'd be much cheaper than going the turbo route, but would I gain a noticeable increase in power? Which is the best way to go—six-into-one single exhaust or six-into-two dual exhaust? Is the standard exhaust system too restrictive to use behind headers?

(3) Electric fan. Would replacing my

standard rigid engine-driven fan with a radiator-mounted, thermostatically controlled electric fan improve my power? I don't believe a flexible fiberglass fan would hold up through one of our 30-below winters.

Peter Winsor, Fortuna AFS, N.D.

If you up power, down will go the mileage. Your big van's aerodynamics and mass are the reverse of what you need to get top mileage. More power means more fuel.

Turbocharging is out as a home remedy. Headers, as a rule, do not really do much today, except in special applications. An electric fan might help—but only a little.

My advice—don't do anything. Rethink the deal and make out as you are. For a van, 22 mpg is good.

Vibration and exhaust noise

I have a 1979 Horizon that has extreme vibration and exhaust noise. Stoplights with the car in drive are a nightmare of vibration such as the old Model A used to produce. I have returned once to the selling dealer, gone three times to a dealer near work, and stopped at another nearby suburban dealer regarding this problem. Total time lost: six days. Result: negative. They claim this is peculiar to four-cylinder engines, and they blame the exhaust-control systems. I say baloney. No car manufactured with these characteristics would be given the high rating bestowed on the front-wheel-drive Horizon/Omni. In addition, I found that turning on the rear-window defroster produces even more engine vibration. Is there a fix? Or must I live with this as the dealers say?

James Mulvaney, Elk Grove Village, Ill.

Check the alternator drive belt. That could be some of the trouble. Also, some exhaust systems have problems at the ball-pocket connection.

Brake squeal

I have a 1978 Ford F250 4x4 with about 9000 miles and front disc brakes.

The brakes squeal frequently. I have had the car to the dealer six times with no fix. Finally he replaced the pads and resurfaced the rotors, which helped for about a week.

A Ford engineer says it's because the brakes are heavy-duty and the pads have to be very hard. To my way of thinking, these two surfaces rubbing together will wear out faster.

Have you any ideas for a cure?

George Churchice, Hudson, Mass.

No good bullet-proof fix, except a high-bucks special lining.

The squeal is the rotor resonating like a musical instrument. The frequency is determined by the composition of the lining and the condition of the rotor in regard to cleaner and contact area.

Limiting the ability of pads to move in any direction except in and out is also effective.

Add-on overdrive

Where can I get information for add-on overdrives? I have a 1970 Chevy Suburban with a four-speed transmission and a 4.11 rear end. I'd like to have this rig fitted with an overdrive to improve gas mileage, which is now about 12½ mpg. I would like to use this vehicle to pull a small travel trailer and would probably want to be able to lock out the overdrive while doing so.

Do you think that these additions weaken the drive train significantly? I'd guess there would be considerable interest in overdrive transmissions, with the price of gas going up constantly.

Neil Eklund, Fairbanks, Alas.

We are trying some Spicer 4800 series. They seem okay, but you can't shift on the run. They're pretty expensive, but they do help and are not too hard for a professional mechanic to install. I would suggest installing them in such a way that you can go back to a standard transmission when you sell this vehicle, and put them in the next vehicle you buy.

Convert to propane?

I would like to build a small-block Chevy from the ground up to burn propane. But I cannot find any information as to optimum compression ratio, valve timing, and spark source. Does it like a spark such as that from a CD system, or a long, high-current Kettering system?

H. L. Phelps, Lakeside, Calif.

Best I know of in this business is Impso Carb, Inc., 16919 Gridley Place, Cerritos, Calif. 90701. Talk to them.

Wants to learn

Like many other Americans, I am feeling the pinch of inflation and want to learn to do some minor auto maintenance and repair.

Would you please recommend a book or books that would give adequate instructions and explanations to satisfy my needs?

Michael Moses, Marietta, Ga.

My first choice is your car's maintenance manual. Where to write for it is in the owner's manual. My second choice is a Chilton Auto Repair Manual.

Each month in POPULAR SCIENCE Smokey Yunick answers questions on cars—family cars, high-performance jobs, hot rods, and racing cars—selected from those sent in by readers. Got a problem? Send it to: "Say, Smokey—," POPULAR SCIENCE, 380 Madison Ave., New York, N.Y. 10017. Questions cannot be answered by mail.



"I studied hands from all over the world, so the OM-1 would fit comfortably in your hands."

The Olympus OM-1 was not an instant camera. It took 5 years for Maitani, the celebrated Olympus designer, to create the world's first compact 35mm SLR.

And you can see why.

Studying the size and shape of hands is just a sample of the total redesign effort that resulted in the OM-1. And the results speak for themselves.

The OM-1 is a third smaller and lighter than its bulky predecessors.

Yet the viewfinder is bigger and brighter. In fact, all the controls are spacious and intelligently placed.

Maitani



Yet compact as it is, the OM-1 is still one rugged camera.

After the brutal life-cycle tests we put it through at the factory, going to the top of Mt. Everest and being mounted on the hulls of ships was child's play for the OM-1.

And the OM-1 is part of the OM system. You can add lenses, winder, motor drive—over 300 components.

The OM-1. No other man could have designed it.

And no other company could have made it.

For more information write Olympus, Woodbury, N.Y. 11797.

OLYMPUS® OM-1

SHOP TALK

By RICHARD STEPLER

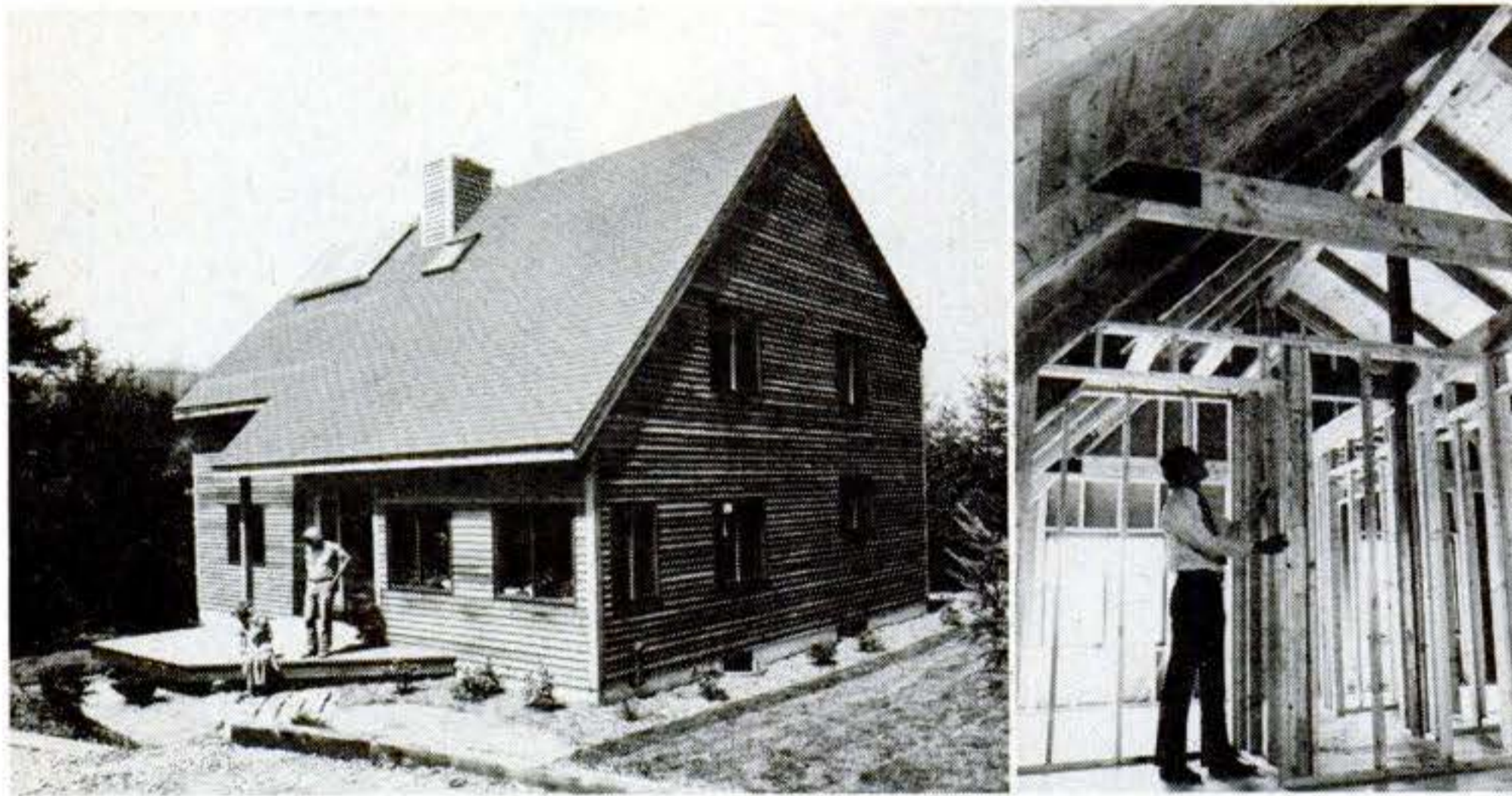

Energy-efficient kit homes

One of the kit-home companies I covered in the June '79 issue ["Kit-Built Homes—Lower-Cost Alternative?"] reports that its energy-conserving, post-and-beam homes are performing extremely well. George MacElhiney, president of Massachusetts-based Timber Kit, cites one example: "Energy (electricity) cost one family only \$325 from September 1 to April 1, plus about \$100 worth of cordwood for a wood stove. The electricity covered the other heat needed in addition to lighting, cooking, refrigeration, hot water, and so forth. Since heating water around here costs \$15 to \$20 a month alone, it's obvious that very little electricity went into home space heating."

Timber Kit's house packages include precut, notched, and numbered Douglas-fir frame members; two-inch-thick pine decking for floors and roof; preassembled 2x4-framed exterior walls; one-inch-thick

urethane for walls and three-inch-thick urethane for roofs; and double-glazed windows. Timber Kit specs also call for 1½ inches of polystyrene under and around foundations. The homes feature a large "ready-for-solar" south-facing roof angled at the optimum pitch for solar collectors (left photo), and lots of south-facing glass.

If you're handy enough to finish the interior yourself—interior walls are non-loadbearing and can be positioned where you want them (right photo)—the company estimates that the completed cost of a home will be twice the kit's price. Timber Kits cost from \$16,000 to \$24,000 and range in size from 1120 to 1890 square feet.

"What we're doing," says Timber Kit architect Blue Minges, "is supplying a house that is going to meet somebody's needs 10, 15, or 20 years down the road." For more information, write Timber Kit, Box 704, Amherst, Mass. 01002.

New catalogs

- The Woodworkers' Store (the new name for Minnesota Woodworkers Supply Co.) marks its 25th anniversary with a 112-page catalog of more than 3000 items including tools, hardware, veneers, and wood products. It's available for \$1 from The Woodworkers' Store, 21801 Industrial Blvd., Rogers, Minn. 55374.

- A catalog covering similar materials is 50¢ from Albert Constantine, 2050 Eastchester Rd., New York, N.Y. 10461. Toss in an extra 50¢ for 20 wood samples.

- The Fall '79–Winter '80 Woodcraft Tool Catalog and a new Project Supply Catalog normally cost \$1 and 50¢ respectively. Woodcraft Supply Corp. (313 Montvale Ave., Woburn, Mass. 01888) will send them free if you mention POPULAR SCIENCE.

Iron-on veneer glue



A new iron-on hot-melt glue sheet should make veneering projects faster and easier. You simply cut a piece of the glue sheet to the size of the area to be veneered, peel

off the paper backing, place it between the veneer and workpiece, and iron it on. The glue's actuation point is 400 degrees F. Make a mistake? Reheat and correct it. A two-by-three-foot glue sheet costs \$2.22; 10 or more are \$1.99 each. Send 25 cents for a catalog of wood veneers and instructions to Bob Morgan Woodworking, 1123 Bardstown Rd., Louisville, Ky. 40204.

Banned in Boston

And in the rest of Massachusetts, too: urea-formaldehyde-foam insulation, as an "unnecessary health risk." Citing a "significant correlation between urea-formaldehyde-foam insulation and certain formaldehyde-linked illnesses such as respiratory difficulties, skin and eye irritations, headaches, and vomiting," Massachusetts public health commissioner Alfred Frechette enacted the ban, effective November 1979, under the state's Hazardous Substances Act. Massachusetts homeowners may even have the material removed from their homes at the manufacturer's expense.

The action is the result of a series of hearings held last spring in which 400 homeowners testified about problems experienced when their homes were insulated with the material. At least 13 families said they could not live in their homes after the product was installed.

U-F foam is pumped into the sidewalls of homes, increasing a typical 2x4-framed wall's thermal resistance from R-4.4 to R-20. We've reported on this insulating material in previous issues; one PS editor even had his own home successfully foamed ["Foam-in-Place Insulation," PS, Sept. '75]. "The Truth About Foam-in-Place Insulation" [PS, Sept. '78] covered the problems that were cited in some installations: cracking, shrinking, and toxic fumes. We concluded then that improper installation was at the root of most U-F-foam complaints.

Says Al Layton, executive vice president of Aerolite Corp., one of the major foam companies: "We recognize when the foam is improperly installed a possibility exists that short-term, low-intensity irritation may occur. Experiences in Europe over the past 15 years and our experience in an estimated 62,000 American homes show a temporary irritation incidence rate of less than 0.07 percent." Layton adds that Aerolite has instructed its dealers and distributors not to install foam in homes where occupants are known to have a history of severe allergies.

According to the federal Consumer Product Safety Commission, more than 500,000 homes nationwide have been foamed since 1976. The CPSC itself has received about 500 complaints on the foam, and is now evaluating several strategies, including product labeling and safety standards, as well as a possible ban on U-F foam. By the time you read this, the Commission will have conducted four regional hearings on foam insulation. We'll keep you posted. Meanwhile, if you have a complaint about U-F insulation, you can call the CPSC on its toll-free hotline: 800-638-8326 (in Maryland, 800-492-8363). □



Satisfaction, Camel Filters style.

Some men taste it all: Rich
warm flavor. Smooth even
taste. Solid satisfaction.

Only from the Camel Filters
blend of Turkish and domestic
tobaccos.

Warning: The Surgeon General Has Determined
That Cigarette Smoking Is Dangerous to Your Health.

Famous Camel Quality!

Invisible doors

pivot on pipe hinges



Hidden doors blend into house wall (above) but swing smoothly open (right) for RV exit. Specially designed hinges



support the heavy doors. To preserve the illusion of an unbroken exterior, the knobless door opens only from the inside.

By **GEORGE E. BUNZER**

Trying to conceal two large doors on our new home started me on an unusual quest—the search for the perfect pivot. The house is the RV Chalet featured in the PS Leisure Home series [PS, Oct. '76]. I designed this cottage both to shelter an RV and to integrate it into the home. The original plans called for an RV-sized overhead garage door, but I later thought doors that matched the reverse board-and-batten siding would be more handsome. I also wanted the doors to match the paneled interior of the house.

But when I looked for hinges that would be both invisible and able to support the weight of these massive doors, I found none available. My solution—galvanized pipe fittings. From $\frac{3}{4}$ -inch pipe flanges and matching nipples I constructed heavy-duty pivot hinges that allow the doors to open exactly 90 degrees. Since there is absolutely no play in the doors, the threaded nipples should outlast both me and my kids.

The length of the nipples is important to ensure proper spacing after they are hand-tightened to the flanges. The $\frac{3}{4}$ -inch flanges make a good fit to both the underside of the header and the top of the 2x4 sill plate. This sill presents no obstacle to

NEW DREMEL BELT SANDER & DISC SANDER IN ONE.

The ingenious combination of a quiet-running, 5" disc sander and 1" wide x 30" long sander-belt makes this the most useful power tool you'll ever own.

The disc handles rough sanding and shaping. The belt sander takes care of the finishing.

3" throat depth, easy belt adjustment make inside sanding simple. Has a platen that provides a rigid sanding surface if you need it but removes for flexible belt sanding.

Great tool if you don't have a workshop. Great tool if you do. Available wherever fine power tools are sold.

Dremel, Division of Emerson Electric Co., Racine, WI 53406.

YOU'LL NEVER RUN OUT OF USES FOR IT.

MODEL 730



Sharpens, polishes, cleans, grinds metal, wood, some plastics.



Large tilting table, adjustable miter gauge for sanding accurate angles.



Compact. Weighs just 11 lbs. Only 15" high x 10" x 11".

DREMEL

Copyrighted material

our RV's wheels, but the plate can be eliminated altogether, and the flanges fastened directly to a concrete floor if desired.

To make the doors "invisible" on the inside of the house, I nailed paneling and trim to their inner faces. For the doors to pivot properly, this trim must be cut precisely to fit the pivot point; then part of the trim must be nailed to the wall (see diagram). To assure proper fit, this tricky cutting job is best tried out first on scrap pieces.

The 3/4-inch gap on either side of the doors is essential—it allows the doors to pivot. But gusts of cold air can't get through. Mitered siding joints as well as weatherstripping around the doors make the opening snug.

The miter joint between the doors also helps keep them tightly shut, as do the foot bolts on the top and bottom of the inside left-hand door.

Though I designed these doors specifically for my RV Chalet, they can also be used as substitutes for ugly doors on an attached garage. And solid pivoting doors would be a heat-saving alternative for sliding glass doors that open to the outside.

FOR MORE INFORMATION

Include a stamped self-addressed envelope with your questions, and send to George Bunzer, Rte. 6, Box 384, Murphy, N.C. 28906. Architect's plans for the RV Chalet cost \$35 for one set, \$50 for four. Materials list is \$10. Send checks to Bunzer at the address above.

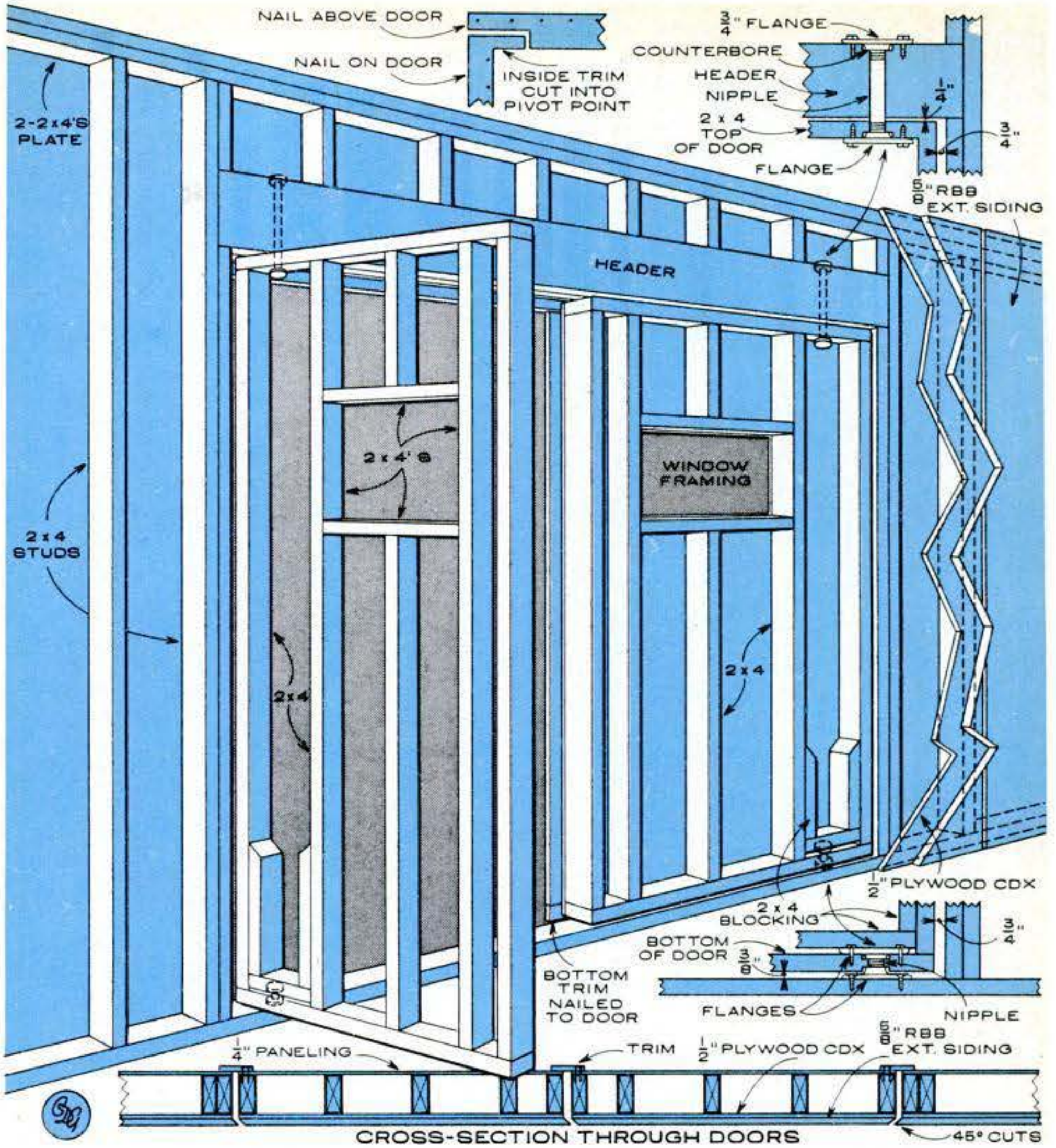

A CLASSIC INVESTMENT

THE CLASSIC AUTOMOTIVE COLLECTOR SERIES



The Bradley T Bird Convertible
1957 Ford Thunderbird Replica



The Bradley MGT Convertible
1952 British Leland MGTD Replica

More than convertibles, the Bradley T Bird and the Bradley MGT typify the fresh feelings of zest and adventure of early sports car design. Bradley Automotive captures the free, fun-loving spirit of the Fabulous Fifties in each replica kit. Delight in creating your own classic difference by going from the ordinary to the ultimate.

Each classic becomes a thrilling attraction; an exact duplicate made of rust-free fiberglass construction. Clear, step-by-step instructions provide ease of assembly. Become the envy of sports car buffs by making a classic investment. Choose the Bradley T Bird or the Bradley MGT in the Classic Automotive Collector Series.



BRADLEY AUTOMOTIVE 14414 — 21st Ave. North
Plymouth, Minnesota 55441 PS-3

Name _____ Age _____

Address _____

City _____

State _____ Zip _____

Business Phone () _____ Home Phone () _____

Send me free literature GTE Electric
 Classic GT Collector Series Classic Mercedes Collector Series
 Classic Automotive Collector Series
 Enclosed is the \$5.00 for the full color laminated 28" x 22" poster for the Classic Collector Series sports cars.
 I am interested in your Field Representative Program.
 The above poster may be charged to your credit card.
 Visa/American Express/Diners/Carte Blanche/Mastercharge

Account No.

**SNAPPER TRACTORS ARE STRONG LIKE THE BIG ONES...
WITH POWER, VERSATILITY AND QUALITY!**



SNAPPER garden tractors were designed by agricultural engineers with quality features. Like an in-line drive train for efficient power transfer and welded steel frames for ruggedness. Another great feature is your ability to "quick change" attachments so you spend less time getting ready and more time working.

You have a choice of gear, or hydrostatic transmissions with "Memory"; manual or hydraulic ASAE standard lift



SNAPPER[®]
Mowers · Tillers · Tractors

systems; rear power-take-off; and 16 or 18 HP engines. In addition, you can have a 42", 48" or 54" trim line mower and a multitude of attachments for gardening and lawn maintenance.

Stop at your local SNAPPER Dealer for YOUR FREE COPY of "How to get the most for your money when you buy a garden tractor"

McDonough Power Equipment
McDonough, GA 30253

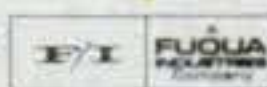

Any way you cut it... it's a snap with SNAPPER!

WORDLESS WORKSHOP

By ROY DOTY

\$50 to Charles G. Bieber of Beltsville, Md., for this idea. Send yours (with Social Security No.) to Wordless, POPULAR SCIENCE, 380 Madison Ave., New York, N.Y. 10017. Only purchased ideas acknowledged.

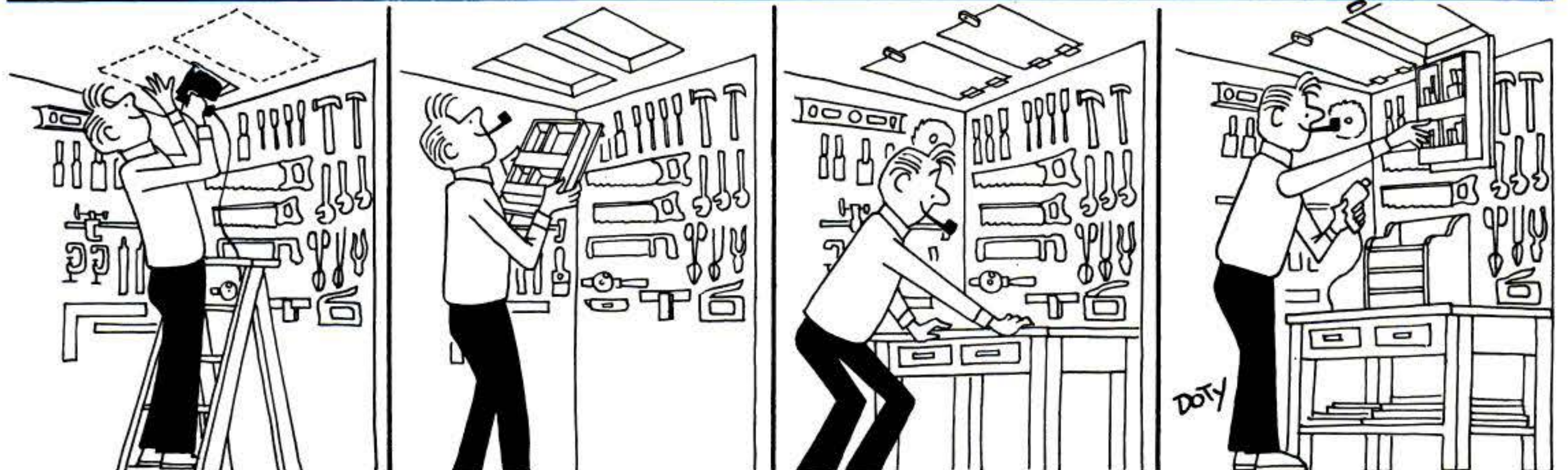
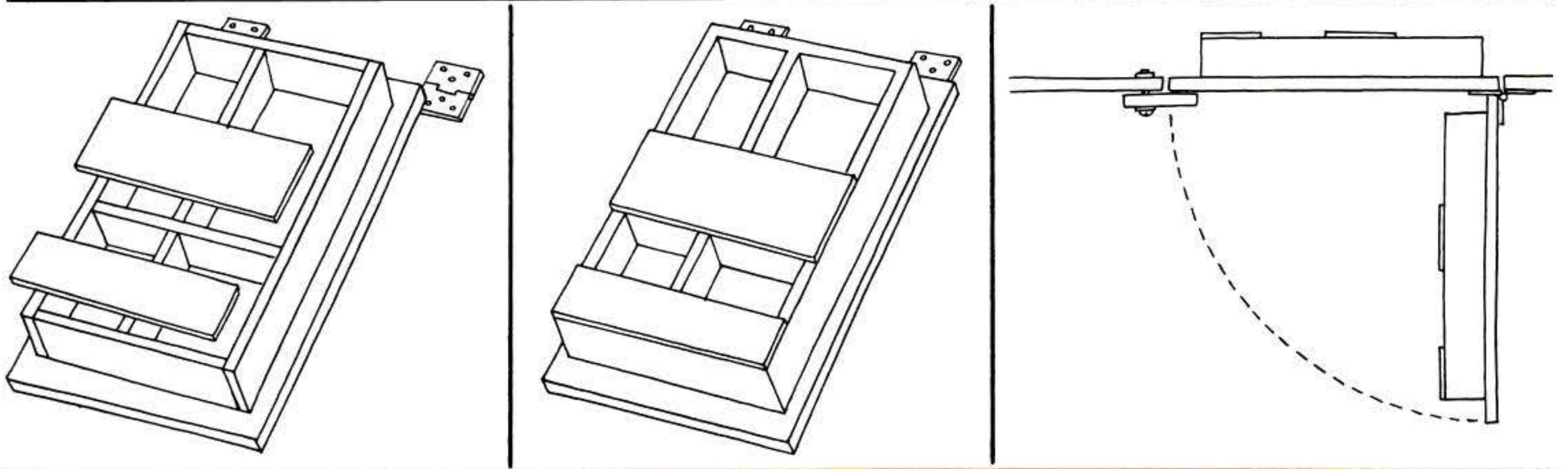

Spotted glasses? Streaky plates? Maybe you've been neglecting dishwasher maintenance

Simple tests and quick fixes can clean up its act

By EVAN POWELL

Like most other appliances, the dishwasher has gained wide acceptance because it saves time. But its true value goes far beyond that. A dishwasher uses less hot water than washing dishes by hand, and it does a better job: Tests show that the bacteria count on dishes is far lower after a dishwasher has been used, due primarily to higher water temperature and stronger detergents than handwashing allows.

So why do you still have dishes with spots and food residue? It could be the washer, but it could also be caused by

some other, nonmechanical conditions.

One requirement for proper dishwasher operation is a hot-water supply of near 140 degrees F. If you've lowered the temperature of your water heater in an effort to conserve energy, you have also unwittingly lowered your dishwasher's performance. Other factors include the amount of hot water available, the type and condition of detergent you use, and dish-loading techniques.

A dishwasher makes use of water pressure, heat, and chemical action. In most modern units, the high pressure is produced by a recirculating pump that forces water through one or more spray arms located where the water jets are directed against the dishes (older models used an open im-

PELLER to "splash" the dishes). But pressure isn't enough. That water must be sufficiently hot to make detergent and greasy food soils soluble, and that result is greatly limited below 130 degrees F.

Chemical action is provided by the highly alkaline detergents that are used. This makes proper action of the detergent dispenser critical, since it is typically dispensed at two different parts of the cycle.

Shown here are the causes and cures for the most common ailments of automatic dishwashers. By understanding the principles, you can apply this information to your specific machine. You'll need no special equipment other than a volt-ohmmeter and

Continued

Inside your dishwasher, electromechanical devices must direct the proper heat, water, and pressure to your dishes for a clean wash. Each device can be checked separately, but first be sure that appropriate loading instructions are followed.

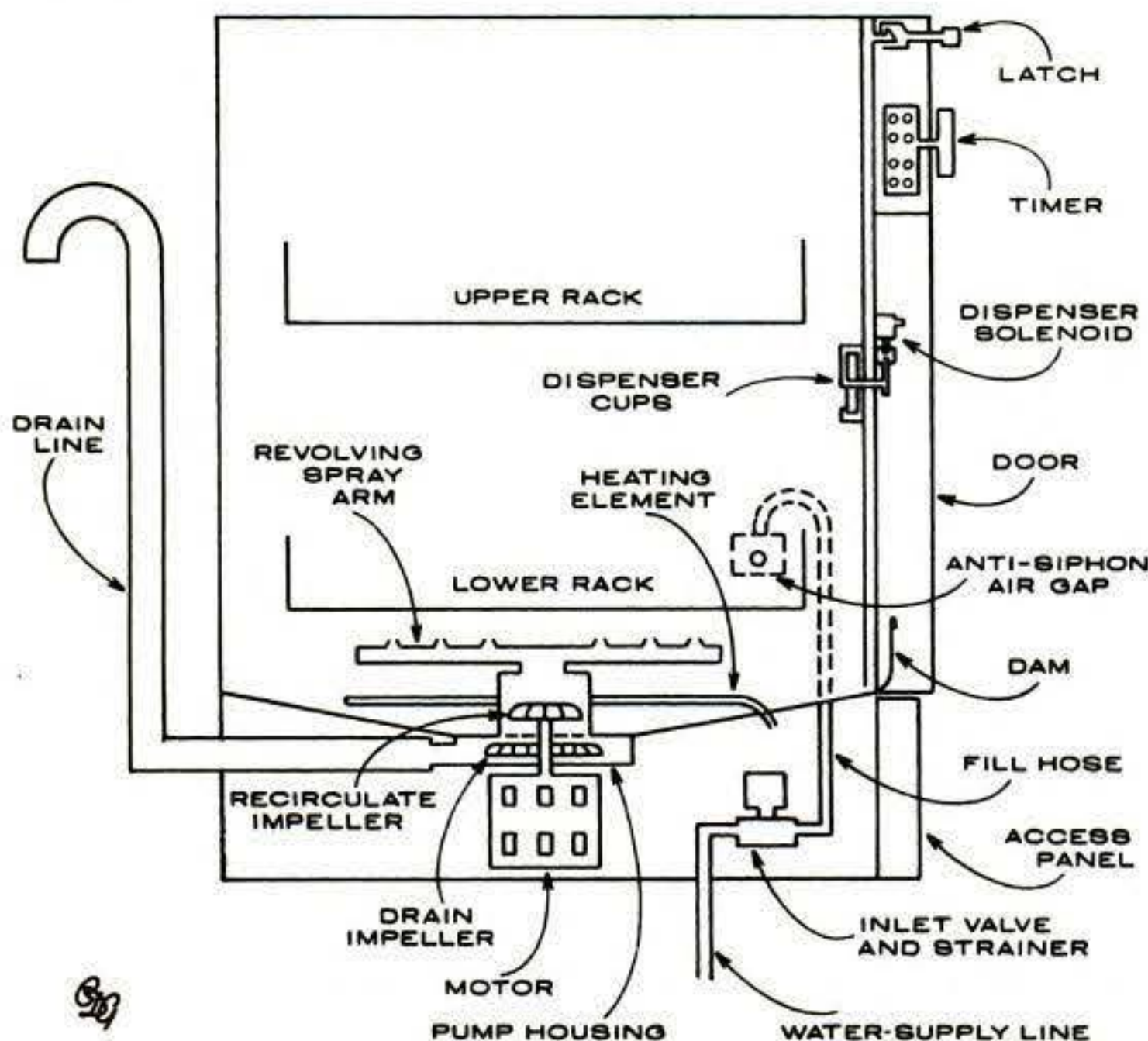

Save a cool \$150*

on Sears Central Air Conditioning System with five-year warranty on compressor

24,000 Btuh Model #81951
Now \$499

Other models also on sale
at similar savings.

Thermostat, refrigerant
tubing, installation extra.

Those hot summer days and nights aren't far off. So start making yourself comfortable right now. Because these efficient Sears Central Air Conditioners are on sale, with energy-saving and quality features like these:

"Silent Sentinel" Electronic Control. Automatically regulates condensing unit fan motor to run at proper speed for efficient cooling and quiet operation.

Wraparound Condensing Unit Coil. Has large heat transfer surface to help minimize operating costs and maximize energy efficiency.

"Super Coil". Provides additional cooling without using extra electricity.

There's even more to the exceptional quality of Sears Central Air Conditioners.

*Sears can arrange
professional
installation.
Ask us for
FREE estimate.*



They're durably built to provide long-lasting comfort. That's why you'll find it hard to beat these Sears warranties.

Full one-year warranty on air conditioner. When installed and maintained in accordance with our instructions, Sears will, within one year from the date of purchase, repair the central air conditioner, free of charge, if defective in material or workmanship.

Full five-year warranty on compressor. For five years from the date of purchase, Sears will replace the compressor, free of charge, if defective in material or workmanship. To obtain warranty service, just contact Sears.

Available at most Sears retail stores.

*These are the minimum savings nationally. Regular prices and dates vary in some markets.

**ON SALE
March 2
thru 22**

**You can
trust your
house to**

Sears

Where America shops
for Value

DO-IT-YOURSELF

FINE GRANDFATHER CLOCK KITS



STARTING UNDER
\$220

(including movement and dial)

- Factory direct prices
- Heirloom quality
- Solid 3/4" hardwoods: black walnut, cherry, mahogany, oak
- Easy to assemble, parts pre-cut
- Solid brass West German chiming movements
- Money back guarantee
- Prompt shipment

MASTER CHARGE and BANKAMERICARD/VISA ACCEPTED

Write for **FREE color catalog**

EMPEROR®
CLOCK COMPANY
WORLD'S LARGEST MANUFACTURER
OF GRANDFATHER CLOCKS

Dept. 339 Emperor Industrial Park
Fairhope, Alabama 36532



LEARN MEAT CUTTING

Train quickly in 8 short weeks at Toledo for a bright future with security in the vital meat business. Big pay, full-time jobs—**HAVE A PROFITABLE MARKET OF YOUR OWN!** Time payment plan available. Diploma given. Job help. Thousands of successful graduates. **OUR 57th YEAR!** Send NOW for a big new illustrated **FREE catalog**. No obligation. G.I. approved. NATIONAL SCHOOL OF MEAT CUTTING, No. 71-02-0197T, Dept. 52-A, 33 N. Superior, Toledo, Ohio 43604.

THROWING AWAY \$5 per lb.?

Everyone has thrown this little known asset away. It is thrown away in every office, home, and all other buildings. Industries throw tons of it away annually. Only 1 person out of 1,000 save it, the other 999 don't realize its value, and the buyers want it kept that way! Hundreds of millions of dollars worth of it go unclaimed, discarded each year!

We will pay you \$5 per lb. for all of this material that you collect. You should start saving yours, and buy it from other uninformed persons for \$2-\$3 per lb. This is a unknown field that should be started part time. Huge income potential. To receive the complete educational package, remit \$7 + \$3 postage and handling. Money refund within 30 days for any reason. **Double your money back with 1st shipment!**

You will learn what we will pay for over 3,000 scrap items, some worth **\$700.00 per ounce**. The average price we pay for these scrap items is \$12.45 per lb. Learn where to find them, how to buy them, and how to ship them. If you have our old book, send it back with \$3 and we will send you the new one. Become a buyer, or at least a saver, we need the material and you can use the money.

Poley's Industrial Salvage Co.
Supply Dept. P-15
12389 Minges Rd., Battle Creek, MI 49017

Dishwasher maintenance

[Continued]

possibly a pair of spring-type hose-clamp pliers.

All these tests and repairs are to be made with *all power removed* from the

dishwasher (unplugged or circuit breaker off). This should be done before making any inspection, and before removing any access panels.

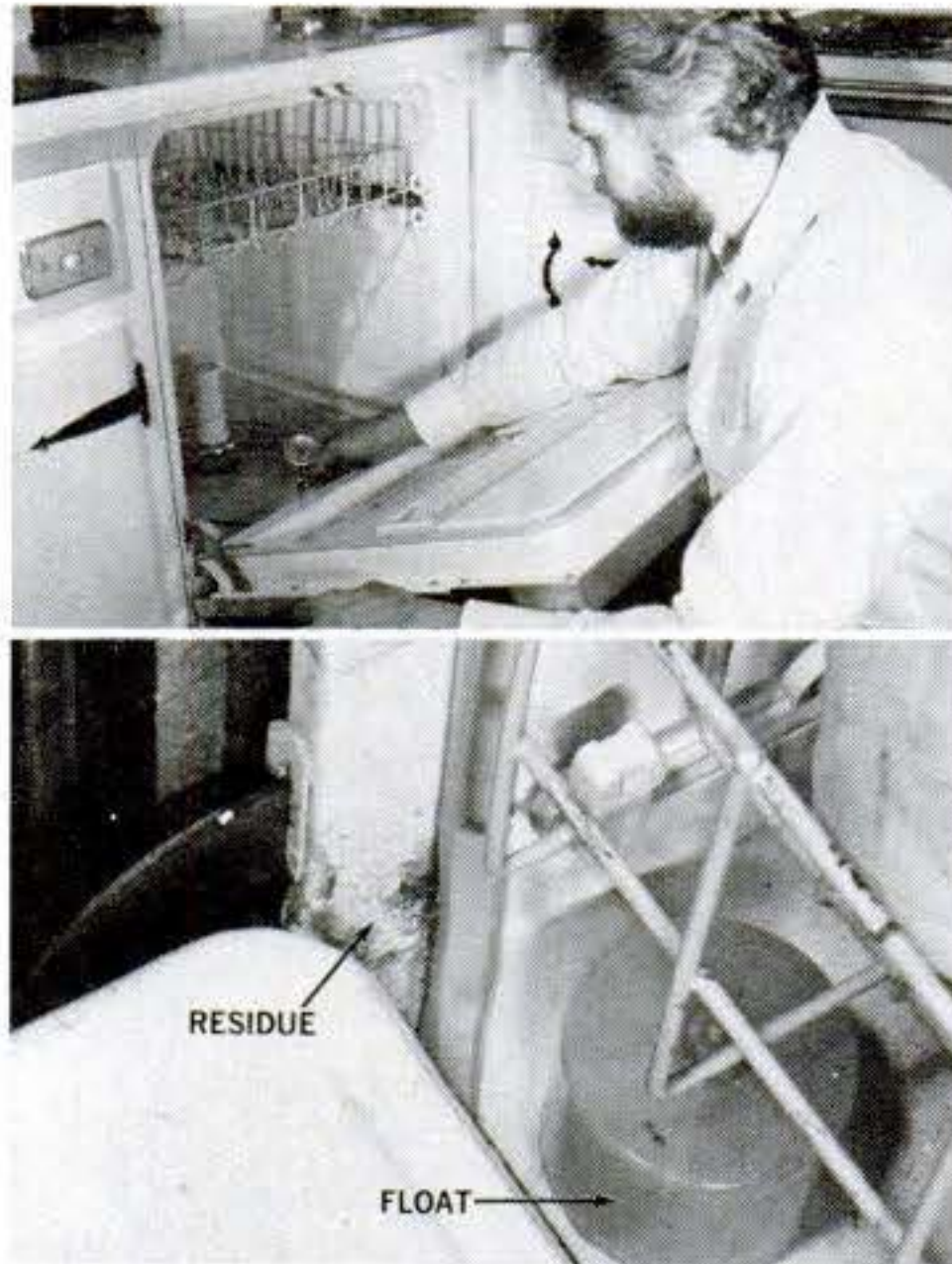

Checking environmental factors

If your dishwasher is a front loader, run your fingers around the lower corners, as shown. A greasy deposit there is an indication of chronic low water temperature. To get a reading, let the dishwasher reach the second fill in the cycle. After the water shuts off, open the door and insert a reasonably accurate thermometer (such as a candy thermometer) in the water. Temperature should be above 130 degrees F. If it's low, consider two alternative methods before raising your water-heater temperature: (1) Insulate the hot-water supply line between the dishwasher and the hot-water heater (building suppliers and heating/refrigeration dealers have cellular-

foam insulation that is excellent for this purpose), or (2) install an in-line booster heater, as I did.

Check the amount of water in the machine. Generally, it should reach or be slightly above the heater in the bottom of the tub (about 2½ inches deep). If it's too low, check the inlet valve first (described below). The float or pressure switch is intended only to shut the valve off in the event of an overflow. It does not control the water level.

Dishwasher detergent formulas vary significantly. Some work best in soft water, others in hard water. If in doubt, poll several local dealers that carry your brand of machine. They should be able to make helpful recommendations. Dishwasher detergents deteriorate rapidly after opening—that's why most are sold in relatively small packages. Never accept a package that has a cut or damaged outer wrapper.

To check your detergent, put two teaspoonfuls in a glass of the hottest water available and stir for two minutes. If a gritty residue remains, the detergent should be discarded.

Water conditions and the condition of utensils and glassware can also cause trouble. These problems range from filming, spotting, and etching of glassware to pitting of metals due to corrosion or electrolytic action. In these instances, check with a local dealer to pinpoint the source.

Dishwasher racks are specifically designed to orient the dishes to receive the full force of the water spray. Review the manufacturer's instructions for loading your dishwasher when you encounter a problem with soil removal.

Checking the inlet valve

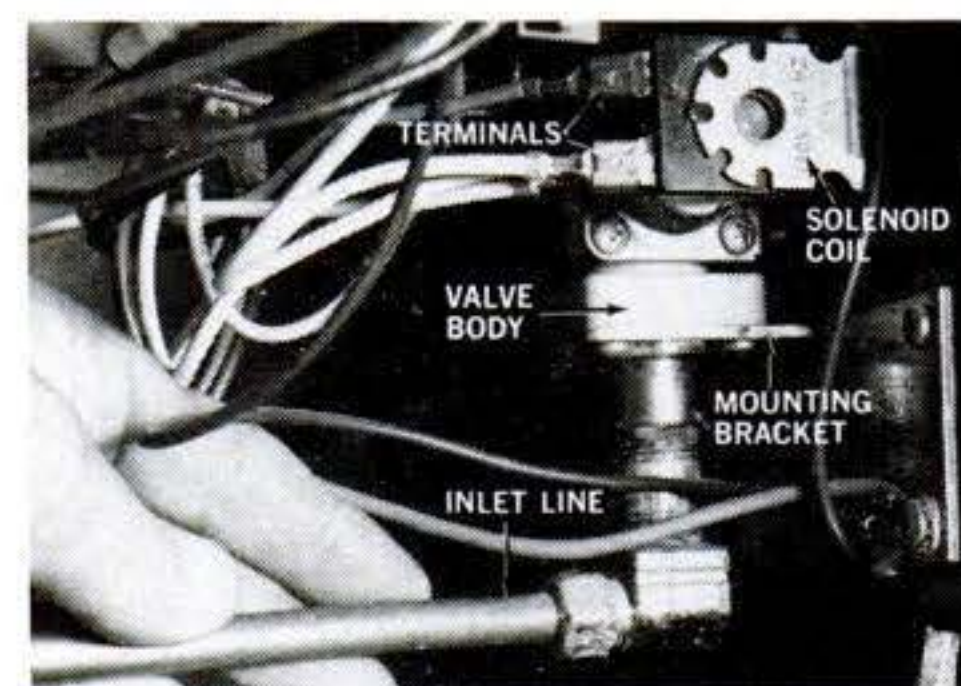

Automatic dishwashers use a single inlet valve since only a hot-water supply line is connected. If no water enters the machine, first be sure that the supply-line valve is open. Then listen closely for a click, followed by a faint humming sound when the timer is turned to the FILL position. (Plug in the unit briefly for this check.) If there's no sound, find the solenoid coil on the inlet valve, located where the supply line is connected to the machine. With power turned OFF, remove one

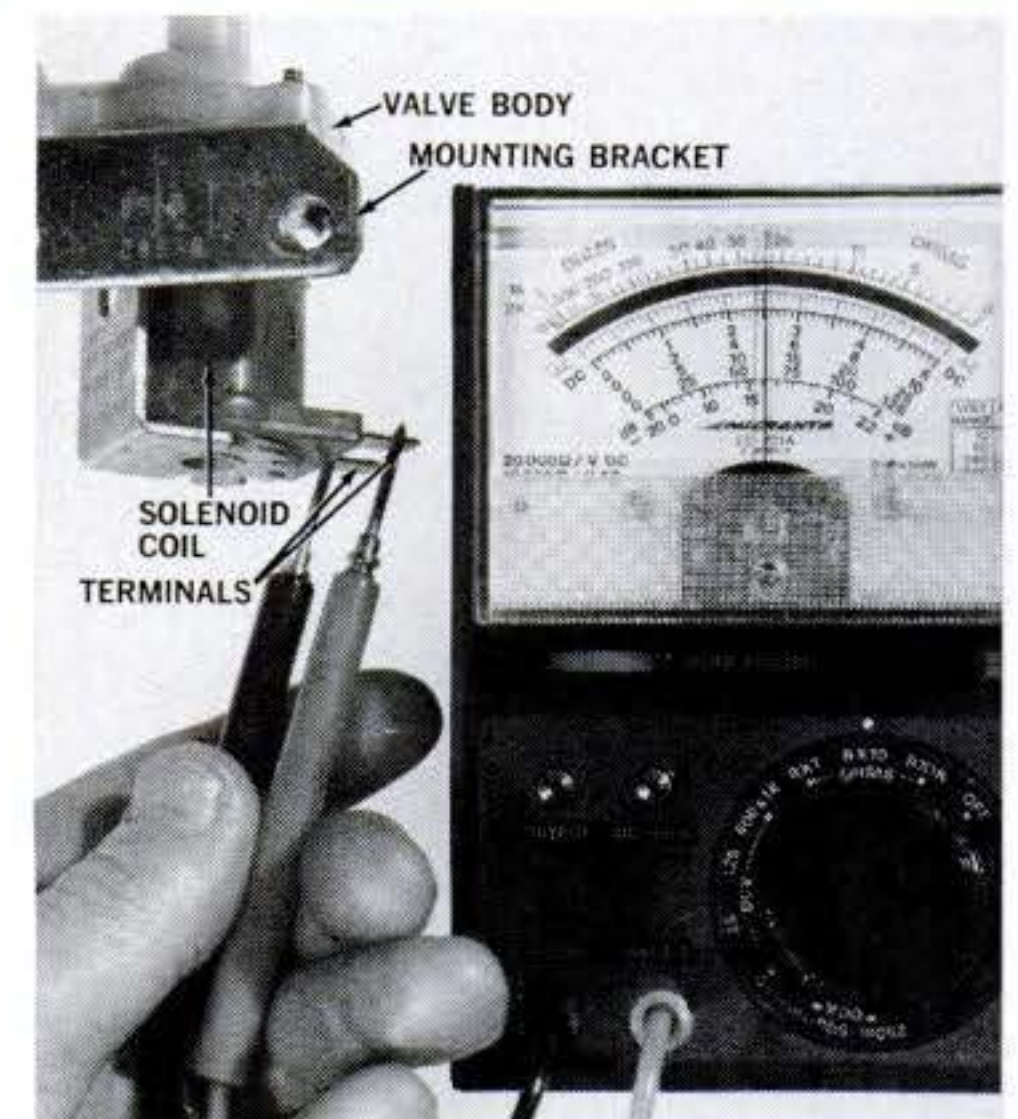

of the solenoid's electrical leads. Use a VOM, set to the Rx100 or next highest position, and place the test probes across the coil terminals as shown. The needle should indicate electrical continuity

Continued

"I wish I'd known about NRI when I was learning auto mechanics."

Says Richard Petty, America's Winningest Stock Car Driver and NRI Automotive Consultant

Even with my Daddy's help, I made a lot of mistakes and wasted a lot of time I could have used today. If I'd had NRI training in auto servicing, I tell you, I'd of learned a lot faster.

NRI Gives You the Training and Equipment You Need to Get Started in a Hurry

There's always plenty of work for a good mechanic. And NRI's training gets you right into it. You get easy-to-understand, "bite-size" lessons with plenty of clear pictures and diagrams. And you get professional tools and instruments you keep to use in your work. NRI calls it "hands-on" training, and I've never seen better.

Learn at Home in Your Spare Time

The NRI people understand what it means to have to earn a living or support a family. So they teach you right at home. You can put your weekends or evenings to profitable use without quitting your job or going to classes. It's a terrific way to increase your skills or start a whole new career.



NRI training includes professional instruments and tools.

Take Your Choice of Two Courses

The good part is, you can tailor your training to your needs. NRI's Basic Course concentrates on the big tune-up field. You also get training in brake work and other basic systems with 30 lessons and all the equipment you'll need. It includes an inductive pickup timing light, ignition analysis and tune-up instrument, tune-up and brake servicing tools, useful maintenance tools, and lots more.

The Master Course includes all the tools and lessons in the Basic Course, plus 21 more lessons and advanced equipment like a carburetor air-fuel tester, silent vacuum test pump, and the latest advance in diagnostic tools, a digital read-out tune-up analyzer that performs over 70

tests. You learn to service engines, suspension systems, front ends, transmissions, electronic ignitions, heaters, air conditioners, take care of a car from bumper to bumper. You're ready to step up to a good job or spare time money with training like this.

I Know It Works

NRI has been in the business of training people at home for more than 60 years. They've enrolled over a million students, started them on their way to higher pay and new opportunities. And they don't pressure you...send the coupon and they'll send their free catalog. No salesman will ever call. I wish I'd done it. If the postcard has been removed, write to address below.

**NO SALESMAN
WILL CALL**

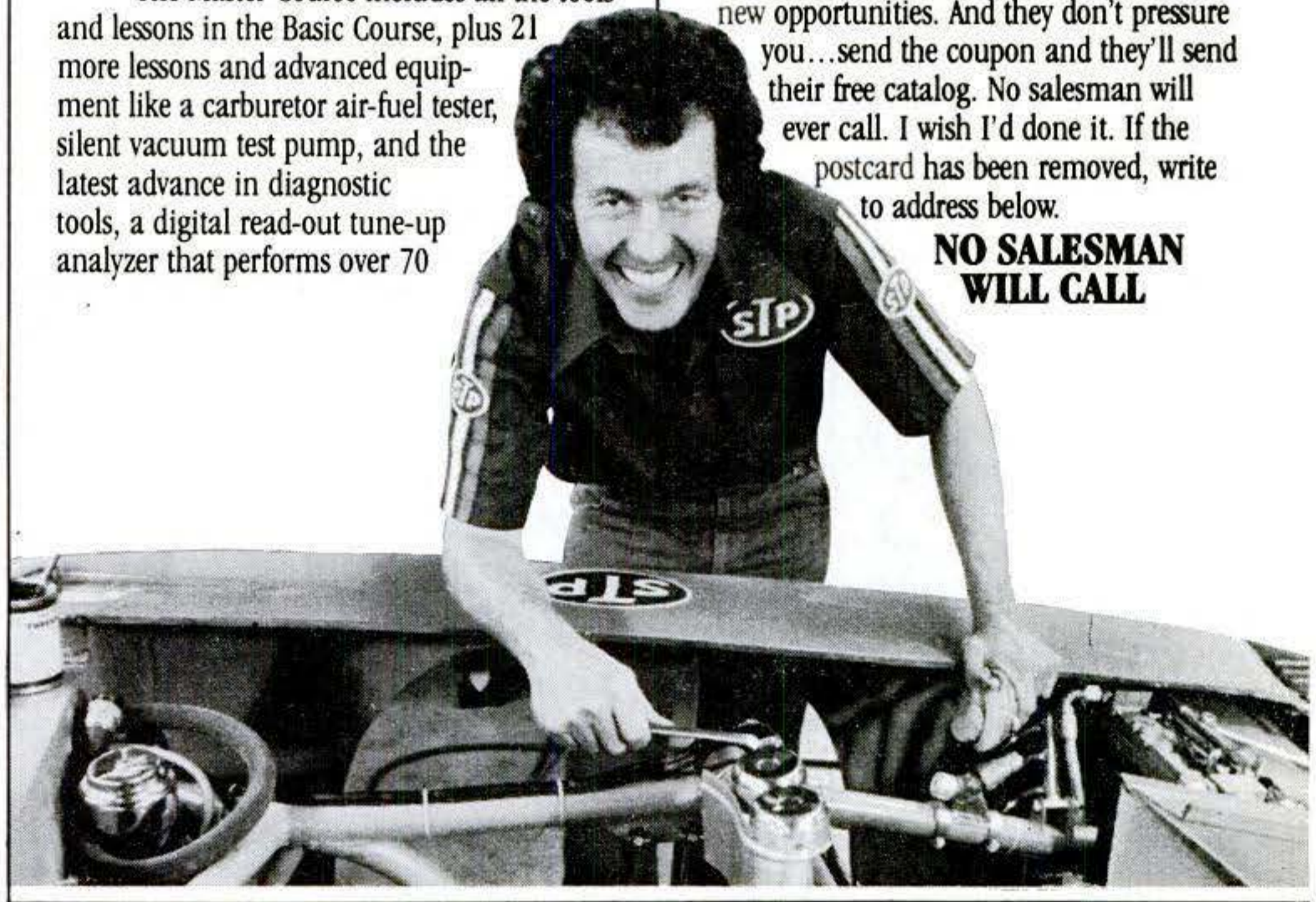

Or check out these other growing fields.

Small Engine Repair

There's plenty of opportunity for the man who can service lawnmowers, garden tractors, chain saws, tillers, outboards, mopeds, motorcycles and other small engines. NRI training includes professional tools...inductive tachometer, volt-ohm meter, torque wrench, valve spring and ring compressors and more. In our Master Course, you actually build a 3 1/2 HP engine as part of your training. Check postcard for catalog.

Air Conditioning/ Refrigeration/Heating with Solar Technology

Gets you into a wide-open, fast-growing area with practical training that includes lessons on solar heating, heat pumps, etc. Complete with professional tools, including

professional vacuum pump for purging systems. Master Course includes optional post-graduate training at York Institute Resident School at no extra charge. Check card for catalog.

Electrical Appliance Servicing

Good appliance repairman are hard to come by. NRI trains you for your own full- or part-time business in fixing everything from mixers to microwave ovens...to refrigerators and freezers. Step-by-step training includes professional instruments and tools for learning and earning. Check card for catalog.



NRI Schools
McGraw-Hill Continuing
Education Center
3939 Wisconsin Avenue
Washington, D.C. 20016

ETHANOL CHEMURGY CORPORATION RELEASES IMPORTANT INFORMATION

HOW TO RUN Energy News YOUR AUTOMOBILE ON ALCOHOL FOR 10¢ TO 20¢ PER GALLON.

Did you know that:

- Nearly everyone can, with the proper permits, manufacture their own alcohol as a fuel.
- You can immediately run your car on alcohol with no major adaptations.
- You can produce alcohol fuel for a cost of 10¢ to 20¢ per gallon and up.
- Alcohol is an anti-knock agent.
- Engines run smoother with no crank case dilution.
- You do not have to pay \$1.00 per gallon to run your present automobile.

Instructions are available on how to build your own backyard still, providing you receive the necessary permits prior to constructing the still. The projected cost is around \$100 to \$150 and the still should produce 10 to 20 gallons per day.

For more than fifty years countless individuals have produced alcohol and used it as a fuel for internal combustion engines. These engines have worked superbly. Here are just a few of the many advantages of using alcohol as a fuel:

Using alcohol, an engine will develop 30 percent more power. Engine operation is smoother, and alcohol lets your engine operate under heavy loads and low speeds without "bucking." Alcohol also serves to loosen carbon accumulations.

Alcohol can be produced in a SOLAR STILL from grains, sugar beets, molasses, lawn clippings, weeds, sawmill waste, vegetables, fruits, etc.

For a limited time, Ethanol Chemurgy Corporation will send to all interested individuals: (1) A copy of their findings on alcohol as a fuel for internal combustion engines, (2) Instructions on where to apply for a permit to manufacture your own alcohol as a fuel, (3) Complete schematic drawings and instructions on how to build an inexpensive SOLAR STILL that you can put together in one afternoon, (4) A list of materials needed for the SOLAR STILL with approximate costs, (5) Basic recipe for producing your

own alcohol fuel, and (6) Information where you can obtain more literature on alcohol as a fuel.

To obtain this information, mail the attached order blank with a check or money order for \$9.95 payable to Ethanol Chemurgy Corporation. We will bill through your VISA or MasterCard account if you prefer. Or, call toll-free 1/800/528-6050, Extension 1020, and your order will be processed within 12 hours. Please have your VISA or MasterCard handy when you call. This information carries a 30-day 100% money-back guarantee.

**Order toll-free by phone:
1/800/528-6050,
Extension 1020**

**Or mail this no-risk
coupon:**

Ethanol Chemurgy Corp.
Dept. P-3 • P.O. Box 220
Orem, Utah 84057

I'm enclosing \$9.95 check or money order. Please rush me the alcohol fuel information described above.

Name _____

Address _____

City/State/Zip _____

Please charge my order to
VISA or MasterCard

Account Number _____

Expiration Date _____

Holder's Signature _____

Dishwasher maintenance

[Continued]

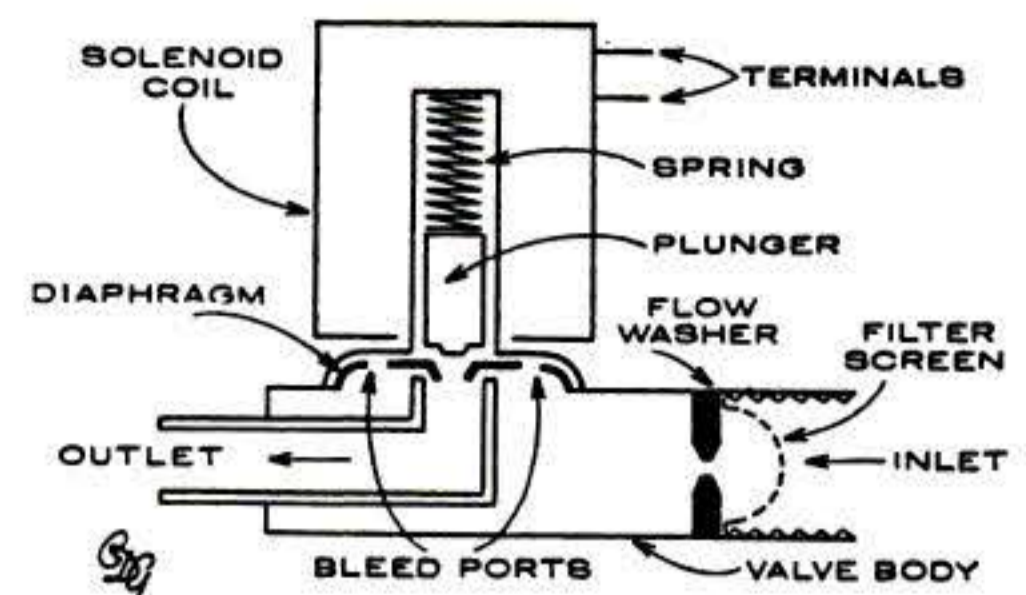

through the coil. If the coil's open (no meter movement), replace it. It's usually held in place with only one or two screws, and often does not require removal of the valve.

Most inlet-valve problems occur when foreign particles such as rust or sand enter through the supply line. This often causes an insufficient water fill. Valves with a brass body usually have a removable "plug-type" strainer. With the water supply turned off, use a wrench to unscrew the strainer cover (normally a large 5/8- to 3/4-inch nut). Remove the filter and rinse the filter screen in running water while brushing away particles (use a toothbrush). Valves with a plastic body must be removed and disassembled to clean the inlet filter.

The inlet valve also contains a flow washer, which is a chambered rubber orifice designed to provide a consistent flow rate at pressures ranging from 20–100 psi. If the washer deteriorates, the water fill may be reduced or "flutter" and hammer rhythmically when the dishwasher is filling. The best cure is to replace the complete valve assembly or use a repair kit that includes both diaphragm and flow washer, since both parts are likely to deteriorate. The drawing shows a typical arrangement of components within the inlet valve.

Foreign particles in the diaphragm bleed ports can keep the valve open even when all power is removed, causing the dishwasher to overflow. The port can be cleaned with a brush and water, too, but you probably won't see the troublesome particle. The port should work when it's reinstalled, however.

Repairing the dishwasher pump

The pump is usually attached directly to the motor shaft or to an extension of the shaft; when the motor turns, water is pulled in from the lower section of the sump (the depressed area at the bottom of the tub) and recirculated through the "nozzles" in the spray arm. To pump out, the motor reverses direction and flow is diverted out the drain valve. Most machines have a two-section pump for this dual purpose, but some have a drain pump driven by a separate motor.

If water is left in the tub at the end of a cycle, or if the dishes aren't sprayed during the wash, it's likely the pump is the cause. It's often necessary to remove the spray arm to reach the pump; as you do, check for foreign particles in the arm and

Continued



Gear breakthrough replaces ratchet catches.

Use it as a winch.

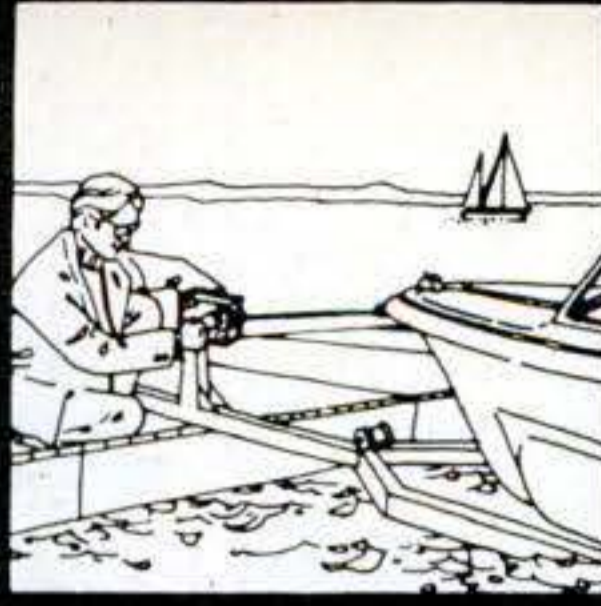

Easy lifting two-speed transmission.

Totally rustproof.

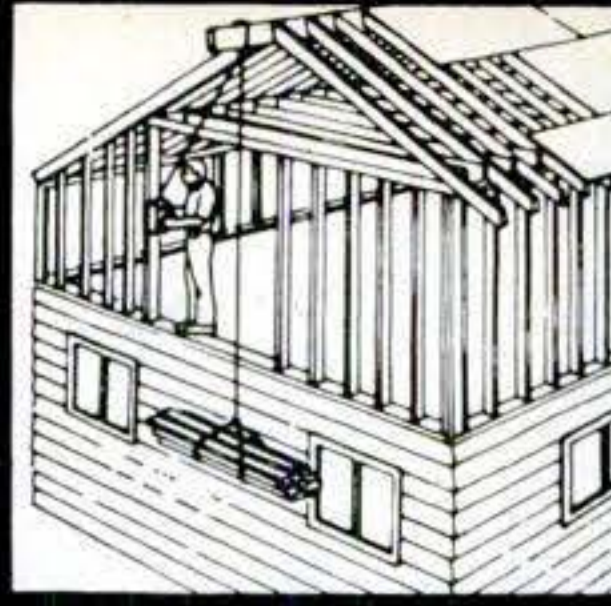

With the Universal Mount, one winch does the job of many.

Saves time and money.

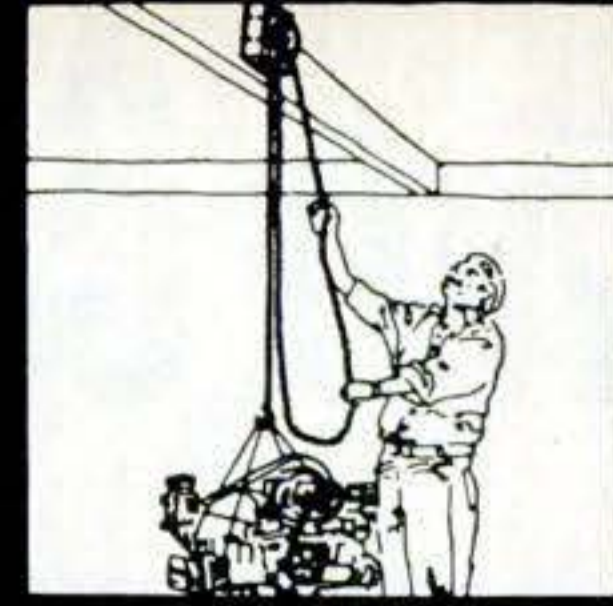

Use it as a hoist.

Use it with your electric drill or socket wrench.

The Easy Tugger Load Handler \$29.50

Save \$200.00 Today



You will start saving money with the Easy Tugger™ the minute you decide to buy one. Instead of charging \$65.00 or \$100.00 for this advanced product, Tool Master has passed on to you the savings made possible by our revolutionary new patented gear breakthrough. With a small investment in an Easy Tugger™ Load Handler, you will increase profits by saving time, money, and trouble.

Low Price
Most companies would introduce this product at a premium and pocket the extra profit. At Tool Master, we believe that if we give you more for your money, you'll buy from us again. The best way to get you to buy from us again is to offer a superior product at a fair price.



Convenience Saves You Time and Money

The Easy Tugger™ makes your work go more efficiently. If you work faster and easier you save time and you get more done. That means money in your pocket. Our electric winches are super time-savers if you use a winch often. Even our cheapest half-ton Easy Tugger™ has the easy lifting two-speed transmission and our special gears which have replaced the old-fashioned ratchet catch. This means that you never waste time winding in the cable and you are instantly ready to lift a heavy load. Wind in your Easy Tugger™ handle, up and down, just like the handle on your car window. It's easy and convenient.

Don't Waste Money

With an Easy Tugger™ you can do more of your own lifting and pulling without hiring expensive extra labor or a service man. Repair your own car. Move things around your house. Carry an Easy Tugger™ next to your spare tire to pull your car out of a ditch or

to use it as an emergency tow cable. Our **Load Handling Handbook**, included **free** with each Easy Tugger™, will make you a pro at pulling and lifting. You save more money with an Easy Tugger™ because you only need one winch to do all your pulling and lifting. The Easy Tugger™ mounts vertically or horizontally almost anywhere with bolts, a chain, a hook, a rope, a stake, or a trailer hitch. The Universal Mount, available separately, allows one Easy Tugger™ to be moved easily and quickly from one job to another; it can be used as a utility winch, a chain hoist, a ratchet hoist, and a load binder. You can take the motor out of your car with the same Easy Tugger™ you use on your boat trailer.

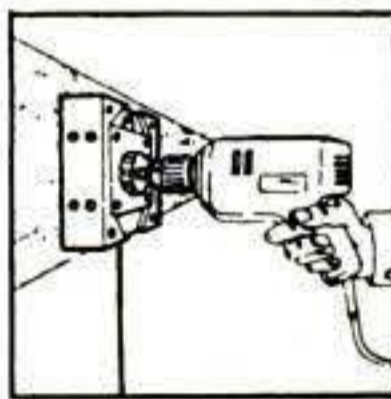
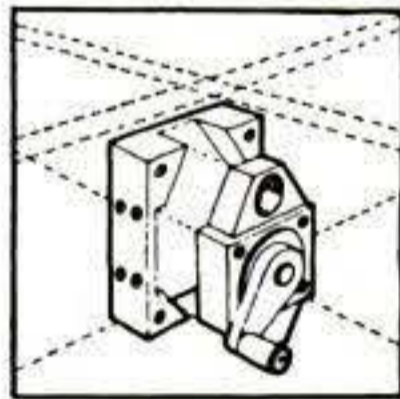

instead of straining your back. Ordinary old-fashioned winches can be dangerous and are in a class with the dinosaur—clumsy, unsafe, and out-of-date. The Easy Tugger™ case protects your fingers and knuckles. A replaceable shear ring prevents accidental lifting of oversized loads that might break the cable. The body is designed to take an 8,000-pound load and our cable has a safety rating four times its advertised strength. We have designed this tool to take abuse so you won't have to replace it. It will last longer and the body won't rust. The Easy Tugger™ is a quality American-made product.

No Risk Guarantee

If you don't see a \$200.00 savings from owning an Easy Tugger™, or if you are not pleased in any way with our product, just send your Easy Tugger™ back in 30 days and your money will be immediately refunded.

For Credit Card orders, call toll free 800 835-2246

Kansas residents call 800 362-2421.

Durable, Safe, and Strong

A safe way of pulling and lifting might save you big money from loss of work and doctor bills from an accident. Use our Easy Tugger™

Tool Master, Inc.
839 Pearl Street
Boulder, Colorado 80302



Please send me:

To: Tool Master, Inc.
839 Pearl Street
Boulder, Colorado 80302

Check or money order enclosed.
 Mastercharge Visa Exp. Date _____

Acc't # _____
Signature _____

Ship to:
Name _____
Street _____
City _____ State _____ Zip _____

Because of demand please allow 45 to 90 days for delivery.

Made in U.S.A.

- _____ 1/2 ton Hand Powered Easy Tugger™ with 12' cable @ \$29.50 _____
- _____ 1 ton Hand Powered Easy Tugger™ with 30' cable @ \$39.50 _____
- _____ 1 ton Deluxe "Endless Chain" Easy Tugger™ with 30' cable @ \$54.50 _____
- _____ 1 1/2 ton 12V DC Electric Easy Tugger™ @ \$99.50 _____
- _____ 1 1/2 ton 110V AC Electric Easy Tugger™ @ \$109.50 _____
- Shipping and handling add \$2.50 for each Easy Tugger™**
- _____ Universal Mounts @ \$5.00 _____
- _____ Drill Adapter @ \$2.95 _____
- _____ Load Handling Handbook @ \$3.50 _____
- Colorado residents add 3% sales tax _____

Total Price _____

PS-3



RELAX & SAVE GAS

Let Cruise Sentry cruise control, monitor your speed, keep "The Bear" from your door and conserve your gas.

Cruise Sentry I or Cruise Sentry II—installs readily in any gasoline powered car, van or truck. Fits domestics and imports, stick or automatic, front or rear drive, electronic or standard ignition.

Cruise Sentry comes with a free full-year warranty—or a special 2-year warranty if you prefer.

Drive relaxed, drive safely, drive fuel efficiently, with a Cruise Sentry cruise control.

Cruise Sentry is available nationally through leading chain and automotive stores.

CRUISE SENTRY

A product of Radatron
P.O. Box 177,
North Tonawanda, N.Y.
14120

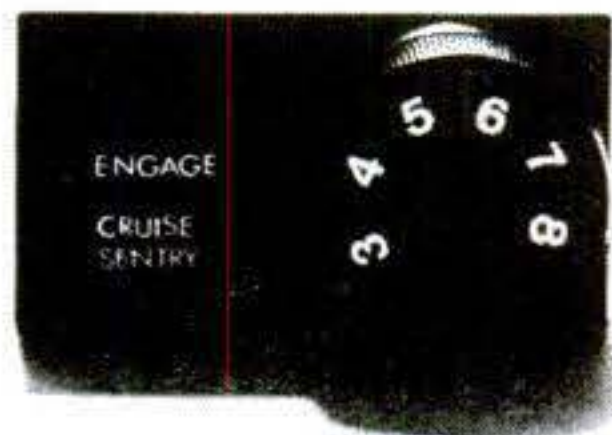

Dishwasher maintenance

[Continued]

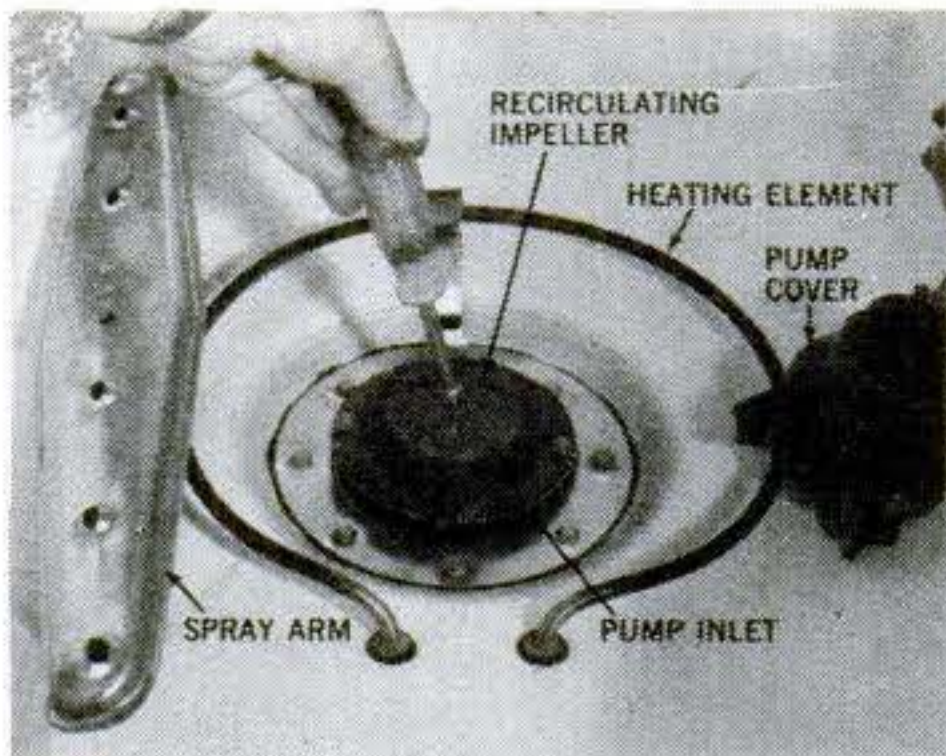

pump outlet. Check around the pump inlet, usually located at the lowest point in the sump, for foreign objects that may have blocked the opening or reached the impeller. Don't use your fingers—broken glass may be present. The pump is usually accessible from the tub, but in some models it's under the machine and reached through the front access panel.

Sponge all water from the sump before disassembling the pump. After the housing is removed, the impeller should be visible. Check carefully for broken blades. If any are sheared, replace the impeller and be sure all pieces of the original are

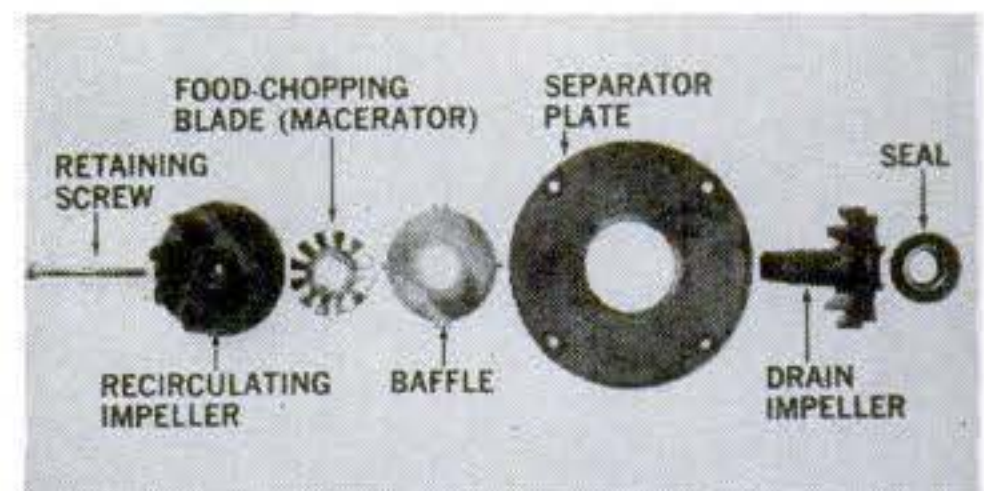

removed from the housing and lines before putting the pump back into operation. Otherwise, you're certain to be in for a repeat performance.

Sometimes impellers are "frozen" to the motor shaft due to electrolytic action between the aluminum impeller and steel shaft. If so, it may be necessary to carefully drill through to the motor shaft or split the old impeller with a chisel. When reinstalling, coat the mating surfaces with anti-seize compound (available from automotive parts suppliers) or silicone lubricant.

While the pump is disassembled, clean the housing and all mating surfaces. Be sure that the lines are clear; and, to insure against leaks, always replace the carbon-faced seal on the pump shaft when replacing other components.

Repairing the door

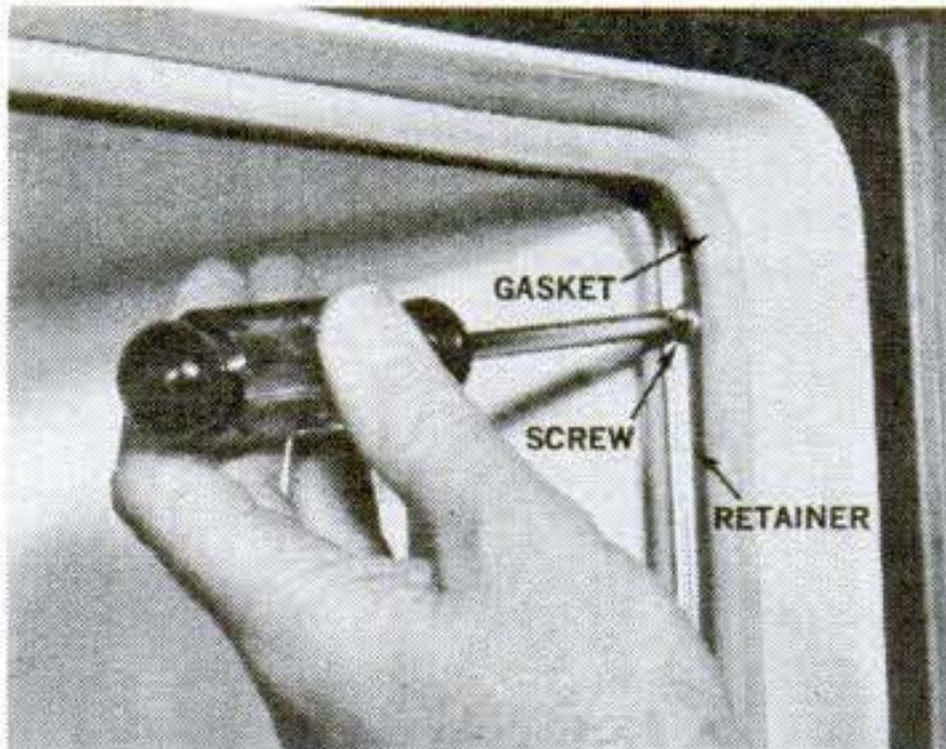

The door to a front-loading dishwasher not only must provide a tight seal against leakage, but it also serves as a vent for the tub compartment and as a container for wiring. Not surprisingly, most leaks on front-loaders occur at the door.

Hard or deteriorated door gaskets should be replaced. They are normally mounted just inside the inner flange of the tub opening or on the door, and are held in place with stainless-steel clips or screws.

Be sure that the hinge assembly is in good condition. With the door open, pull the upper corners from side to side and watch for movement in the hinge area. If it moves, check the mounting screws and rivets that hold the hinge together. If the hinge is bent or worn, replace it.

To reach components within the door, separate the inner and outer door shells by removing screws from the sides of the interior panel (see photo). One source of leaks that isn't obvious is the dam, a troughlike affair within the bottom of the door. Here, water from the tub actually enters the door. The trough is usually sealed at the side with several gaskets. If

they have deteriorated, coat the replacements with silicone sealer to make them last longer and guard against leaks. Oversudsing, caused by too much or the wrong type of detergent, or a leaking spray arm can also cause water to overflow at the dam.

The latch mechanism is critical. It usually contains a two-stage lock for positive latching, and an interlock switch to cut power if the door is opened during operation. If the machine fails to operate (and you're sure power is reaching the machine), check the interlock switch using the VOM set to the Rx1 scale. With the door closed and latched and one lead disconnected from the switch, the VOM needle should move to indicate continuity. When the latch is opened, the switch should open. The switch may be located within the door itself or in the top panel of the washer.

If you suspect a wiring problem or are investigating an arcing condition, first check the wiring harness where it enters the bottom of the door. Next, look for loose terminals at other door-mounted primary control components, such as the dispenser and timer.

When reassembling, you must align the door before the final tightening of the screws. The door-latch strike on the body of the machine is adjustable (to seat the door tightly against the gasket) by removing or installing shims, or by screwing the latch deeper into the cabinet.

Curing dispenser troubles

The dishwasher dispenser must introduce the detergent to the water at the proper time. It often consists of two containers; one is always open and another springs

Continued

Are old sailing ships becoming an

Endangered Species?

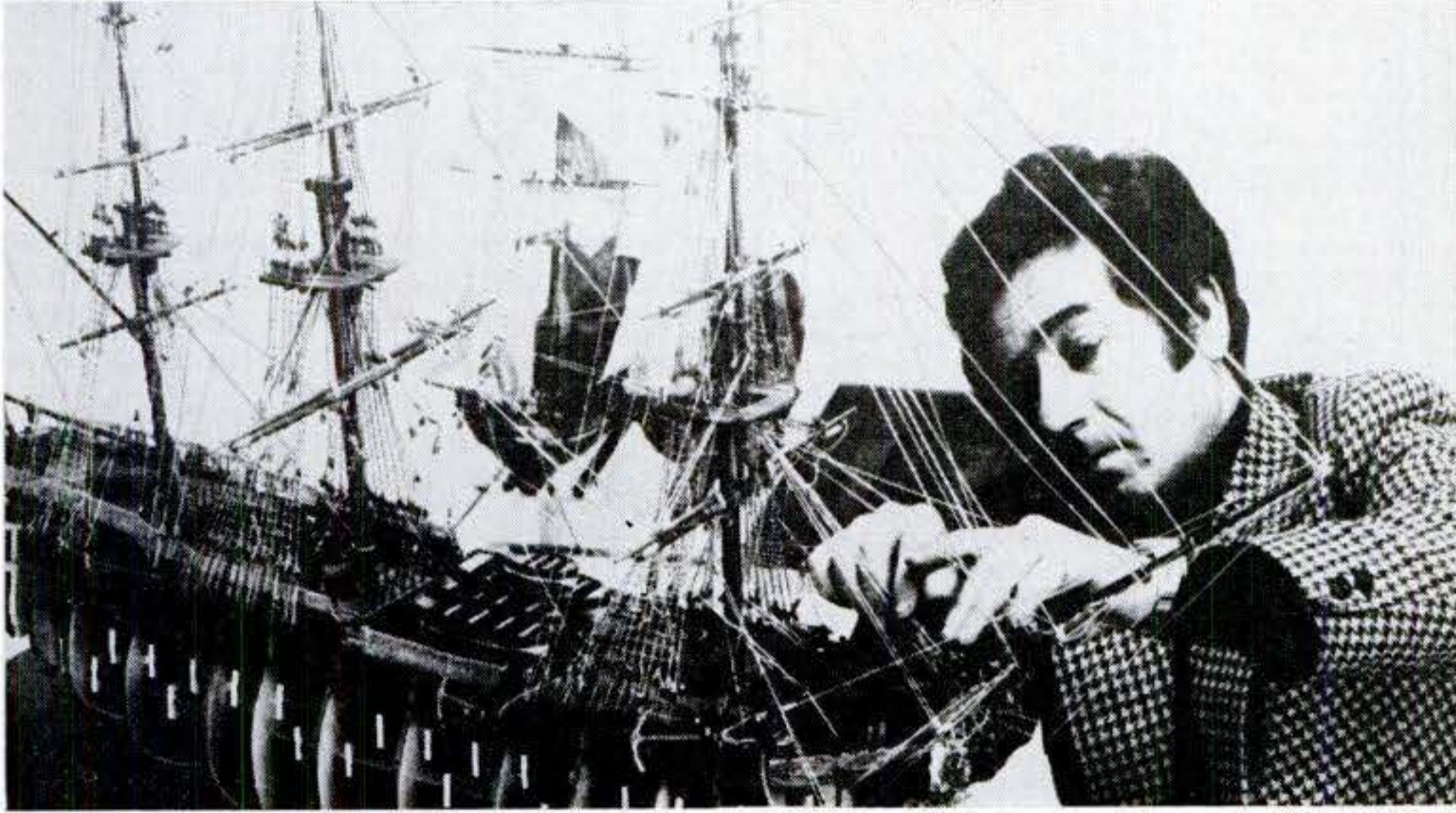

What a thrilling scene: a classic square rigger, sails billowing in the wind, rising and falling on the ocean swells! Truly a rare sight these days—seen only on television or at specially staged harbor festivals. Or in seafaring museums, where we stand in awe of the tall ship models that the skilled hands of old-time craftsmen created.

But there are growing numbers of people who believe that accurate wooden replicas of historic sailing ships make magnificent keepsakes, to remind us of our heritage and to preserve, firsthand, man's link to the sea. And when these replicas can be easily made—even by those who have never before attempted such a project—the rewards of building one's own museum-quality ship model can be tremendously satisfying.

A BREAKTHROUGH IN KIT PARTS & INSTRUCTIONS

Perhaps, when you look at one of our finished ship models you may say, "That's beautiful, but it's obviously been made by an expert." Wrong.

We know that 90% of our customers are beginners—people who've never before built a model ship. They learn as they go along, following simplified plans, and produce remarkable results. Yet our kits are considered by many experienced ship modelers to be among the best in the world. They employ fine woods such as walnut and mahogany; fittings, cannons, and anchors are of finely detailed brass or cast bronze; blocks and deadeyes are shaped and finished from hardwood. In one of our models, a single ship's lantern is made of 4 brass turnings, 6 connecting bars, a see-through baffle plate, and a decorated support shell with shaft and rod! You build just the way the old ships themselves were constructed: you lay the keel, align the ribs, and fasten one plank at a time to form the hull and decking. Our crisp, clear drawings and notes guide your every

step. The final result: often a veritable museum piece, worth far more than its modest kit price.

HERE'S HOW YOU GET STARTED

Kits come in varying sizes, prices, and degrees of complexity. As a beginner, we suggest you start with a model that is relatively easy to build. We know that when you complete it, you'll be back for another, and we'll keep you as a ship modeling customer.

The Baltimore Clipper Ship *Albatros*, 27½" long and 20" tall is our first choice for the beginner. It has a plywood keel and frames, boxwood hull planking, mahogany deck, walnut masts, capstan and trim. She carries seven turned brass cannon, all mounted on carriages. Estimated construction time is about 100 satisfying hours. The *Albatros* regularly sells for \$69, but you may purchase it at the special introductory price of just \$59.95 if you mention this ad with your order. We'll also include, at no extra cost, a *Lusci Ship Model Builder's Handbook*, the "Bible" of the shipmodeler—a \$15.00 value.

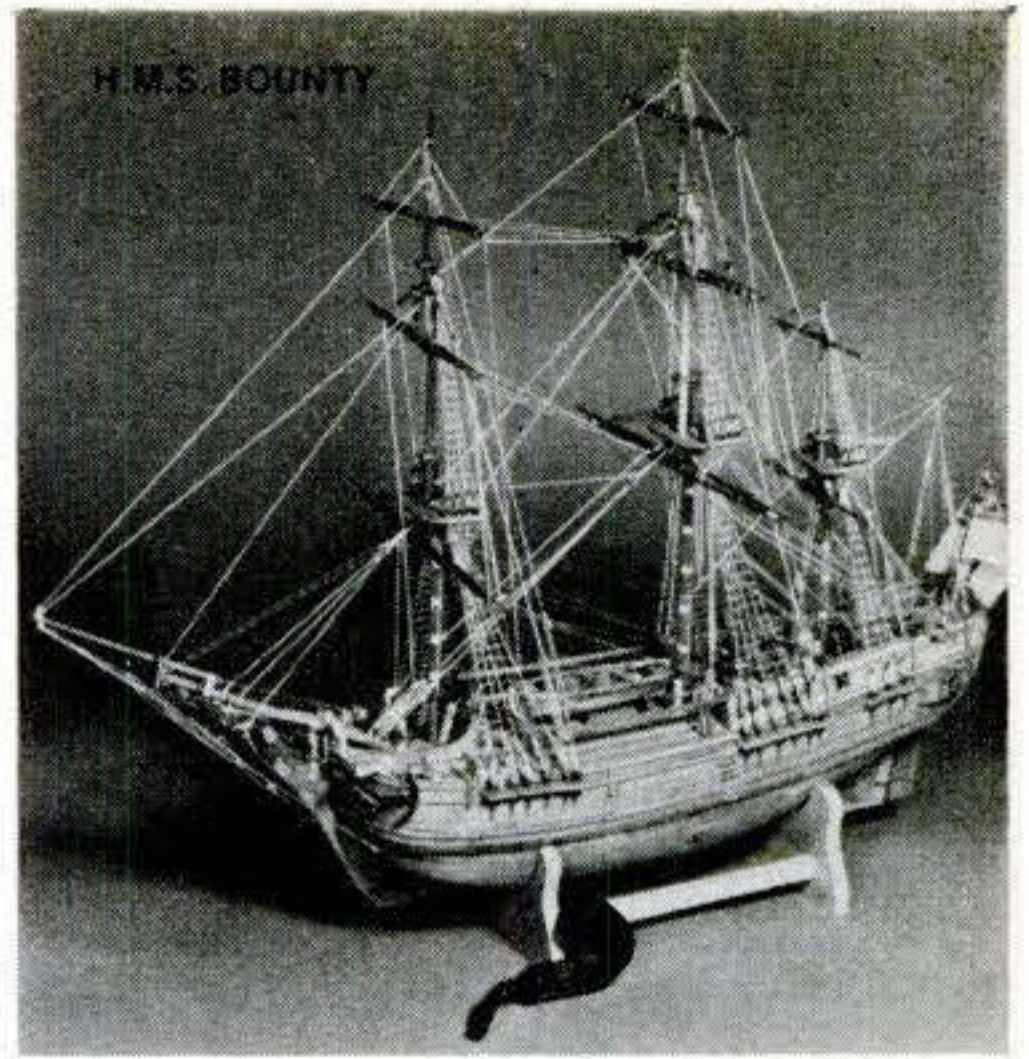
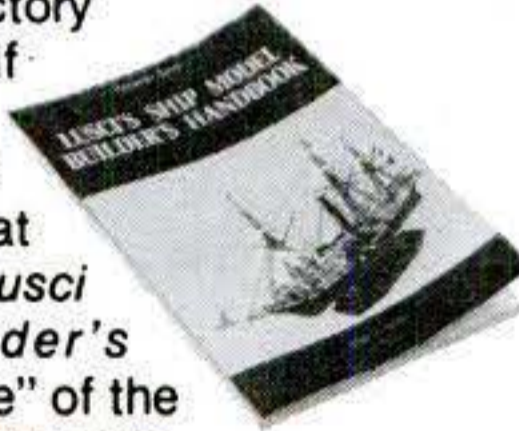

H.M.S. Bounty, whose name is synonymous with "mutiny," needs little introduction. The completed model, 36" long and 25" tall, is impressively large and fully detailed. For those who have never built a ship before, but have some dexterity and perhaps some experience building other types of models, the *Bounty* would be our second choice as a starter kit. Her hull is double planked for greater strength, with both boxwood and walnut strips; her guns, stern galleries, transoms, and bow ornaments are brass; she carries a cast bronze figurehead and hundreds of finely detailed fittings. Sails and rigging lines are included. An excellent value at her regular price of \$198, she's an even better buy at the special introductory price of just \$159.95. A *Lusci Handbook* will also be included, free of extra charge. The finished replica of *H.M.S. Bounty* is certain to be the envy of all who see it proudly displayed in your home or office.

To order either of these ships, mail the coupon below with your check or money order—or charge to your credit card. We pay all postage and handling charges.

For faster service on credit card orders, call collect:

(201) 575-6253.

Help save an endangered species!

model expo, inc.

230 Second Street, Dunellen, NJ 08812

We publish a 68-page full color catalog illustrating our entire line of 40 available models and hundreds of fittings and accessories. It will be included at no charge with your order. If you wish to purchase the catalog separately, it costs \$3.00, which will be refunded with your first kit order.

Model Expo, Inc.

23 Just Road, Fairfield, NJ 07006

Dept. PS-3

Please send me:

- Albatros Kit(s) and Lusci Book @ \$59.95
- H.M.S. Bounty Kit(s) and Lusci Book @ \$159.95
- Catalog(s) (Free with kit order.)
- If purchased separately @ \$3.00

N.J. residents include 5% sales tax.

- Check or M.O. Enclosed.
- Please charge my Credit Card:
 American Express Visa Master Charge

Card No. _____ Exp. Date _____

Signature _____

Name (print) _____

Address _____

City _____ State _____ Zip _____

© Model Expo, Inc. 1979

75 MPG!

**TOP SPEED OF 90 MPH!
1,125 MILES OF DRIVING
(from a 15-gallon fuel tank)!**

That's the kind of high-mileage, fuel-pinching performance you can get — right now — with the amazing HYBRID ELECTRIC CAR! What's more . . . you can build it yourself!

HOW IT WORKS

All you do is take your existing car (or buy a used body) and replace its original power plant with a small gas-powered lawn mower engine. (That's right, a lawn mower engine!) This engine drives a generator which, in turn, supplies the vehicle's drive motor with electricity allowing you to travel at speeds up to 50 MPH.

When more power is needed, four automobile batteries — hooked up in series and fed by a 100-amp generator — give you plenty of kick for passing, climbing hills, and for running at higher speeds (up to 90 MPH) . . . and to help save normally wasted energy, a regenerative braking circuit automatically converts the drive motor into a generator that feeds and charges the batteries *while the vehicle is decelerating!*

Your total cost — by buying your own parts and building it yourself — is under \$1500. Your first year's benefits alone — in fuel savings *and* in hassle-free driving — will more than pay for the car!

GET ON YOUR WAY TO HIGH-MILEAGE MOTORING . . . NOW!

THE MOTHER EARTH NEWS® — the national magazine long recognized as a leader in alternative energy — offers you a detailed, step-by-step set of plans for making the HYBRID ELECTRIC CAR. The complete package includes the plans, bill of materials, and list of suppliers. The plans sell for \$15.00 and come with a no-risk guarantee. To order simply fill in the coupon below and mail it — along with your payment — to: MOTHER'S PLANS, Dept. SP-3, P.O. Box A, East Flat Rock, North Carolina 28726.

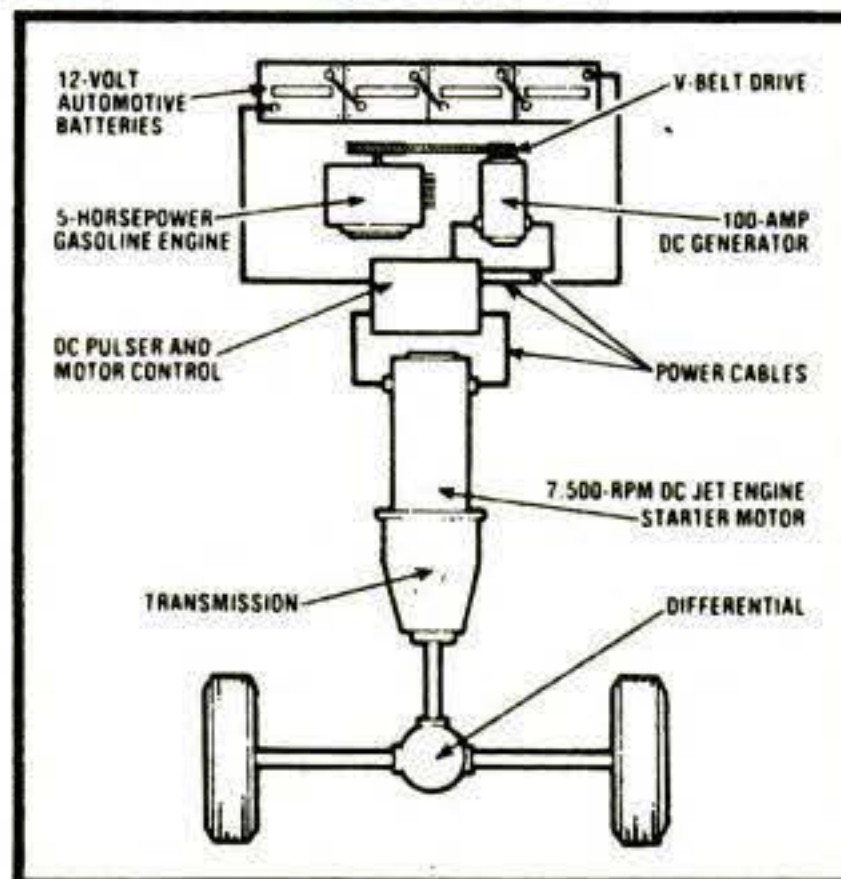

The layout of the new drive system.

Enclosed is \$15.00
Please send me the HYBRID ELECTRIC CAR plans. I understand that I have 10 days to examine the plans, and if I decide not to use them, I can return them for a full refund.

Ship To:

NAME _____ ADDRESS _____

CITY _____ STATE _____ ZIP _____

CHARGE IT TO MY MASTER CHARGE OR VISA CARD

NAME _____ ACCOUNT NO. _____ EXPIRATION DATE _____

MASTER CHARGE INTERBANK NO. _____ SIGNATURE _____

Add \$1.00 if you wish to have your plans sent first class.

North Carolina residents add 4% sales tax.

MOTHER'S PLANS, DEPT. SP-3, P.O. BOX A, EAST FLAT ROCK, NORTH CAROLINA 28726

Dishwasher maintenance

[Continued]

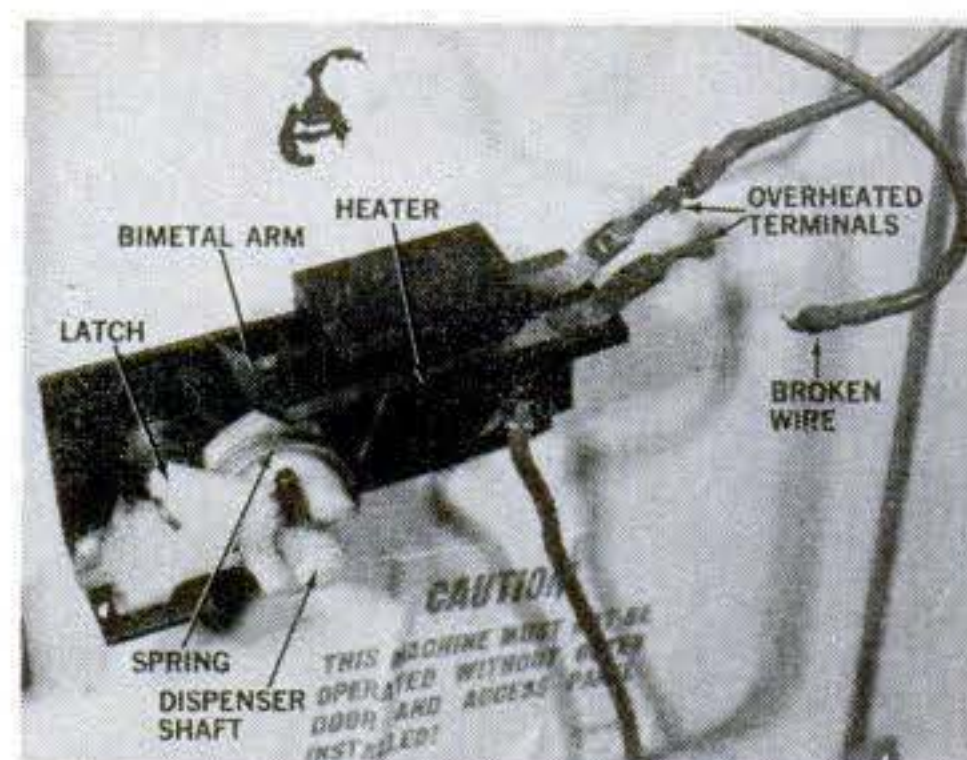

open to add another charge of detergent to the second wash cycle. Usually this is controlled by either mechanical linkage, an electric solenoid, or a bimetal heating device that unlatches the spring-loaded dispenser when energized by the timer.

First, be sure that the dispenser is operating freely. Close the spring-loaded container, then manually actuate the solenoid or heater. If the container sticks, detergent or food residue may have seeped into the linkage. This linkage is usually made of plastic and can be disassembled. Check the condition of the O-ring seal on the dispenser shaft, clean all surfaces, then coat them with a light coat of silicone grease before reassembling.

To check a solenoid or heater, remove one of its leads and use your VOM set to the Rx100 scale. Place the test probes across the terminals. The needle should indicate continuity.

On heater-actuated dispensers look for loose or burned-off terminals (common problem). When replacing, use only heat-resistant wire and terminals. (Some manufacturers sell prefabricated lengths of wire with new terminals already attached.) Polish the heater-terminal connection until it's shiny before attaching the new wire.

Some dishwashers have a liquid-wetting-agent dispenser to prevent streaking during the drying cycle. This is often a solenoid-operated dispenser that injects a few drops of the agent into the water during the last rinse cycle. This may be tested for continuity with your VOM, as well.

Timer troubles

If one or more cycles don't appear to be operating, the timer system may be at fault. Dishwasher timers consist of motor-driven cams that actuate various switch contacts at each portion of the cycle. They range from conventional timers (with a control knob on the timer shaft) to compact "pancake" timers that fit between the door panels and are set with push buttons.

The switches can be tested for continuity (disconnect one wire) as in previous tests. The timer drive motor can be tested by setting your VOM to the highest resistance scale, removing one of the two motor leads, and placing the test probes across the two motor terminals. The meter should indicate continuity. A timer motor can be purchased as a separate component for much less than it would cost to replace the entire timer. [9]

THE FUN MACHINES

. . . that work, too!

SUPER BRONC

- FUN TO BUILD!
- FUN TO RIDE!

These rugged off road vehicles are powered by 5 hp to 16 hp American-made engines.

Engine is completely assembled, frame is welded and painted. You just bolt everything together and start riding.

Kit priced from \$479.95 to \$999.95.

For a FREE color

brochure with complete details, write today to:

Carl Heald, Inc. Dept. PS-03 P.O. Box 1148, Benton Harbor, MI 49022

From the largest Maker of Bike and Tryke Kits in the World — Carl Heald, Inc.

6 BIKE MODELS

7 TRYKE MODELS

SUPER TRYKE

Innovations

The sharpest picture ever achieved in big-screen projection TV

The new Heathkit Screen Star sets a new standard in picture quality for big-screen projection TV. The finest F1.0 lenses you can buy produce one of the clearest, brightest pictures ever.

Imagine watching all your favorite TV movies and sports events on a big 6-foot diagonal screen. Heathkit's three-tube projection gives you brighter, more vivid color. And it's a lot easier to build than conventional TV's.

A complete computer system in one compact unit

The Heathkit All-In-One Computer takes the guesswork out of selecting a balanced computer system. It includes built-in floppy storage, smart terminal, heavy-duty keyboard, 12-key numeric pad, Z80 CPU, and 16K RAM expandable to 48K—all in one compact unit.

Two Z80 microprocessors mean terminal and computer never share power. So both can operate faster on more complex programs. And there's no better way to learn about computers than to build one yourself.

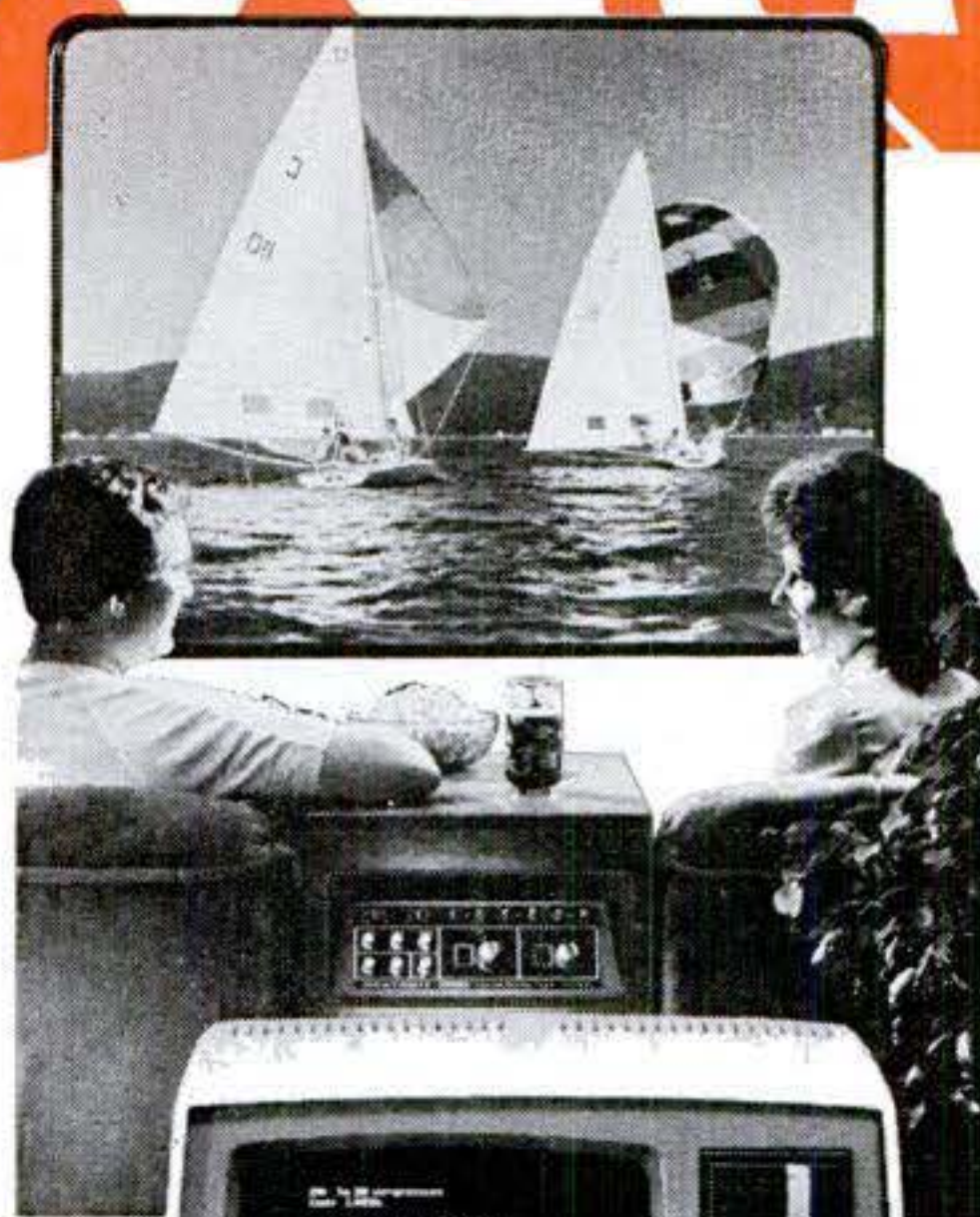

The only computerized home weather station for instant, up-to-the-minute weather reports

Just push a button for reliable weather information anytime you need it with the unique Heathkit Weather Station.

It gives you digital readouts of F or C temperatures, wind speed in miles or kilometers per hour or in knots, wind direction, barometric pressure, date and time of day, even the wind chill factor.

This microprocessor-based weather computer has memory to store data and precision infra-red sensing devices built into the outdoor transmitter. And it's very easy to build.

The finest stereo receiver ever introduced by one of the leaders in audio technology

It's loaded with luxury features that let you adjust your music to your preference.

Special features include a Precision Tuning System (PTS) that automatically corrects mistuning. 5-section FM tuning capacitor gives you maximum rejection of unwanted signals for lower noise, cleaner sound. Digital frequency readout, center tune meter, and flywheel loaded tuning are just a few of the luxury touches. Complete specifications are in the latest Heathkit Catalog.

FREE CATALOG

See all the newest innovations in build-it-yourself kits in the latest free Heathkit Catalog. It contains nearly 400 exciting kits for your home, work or pleasure. Send today.



Send to: **Heath Company, Dept. 016-632, Benton Harbor, MI 49022**

Yes, please send me a Heathkit Catalog.
I am not currently receiving your catalogs.

Name _____

Address _____

City _____ State _____

CL-725A Zip _____

Heathkit®

If coupon is missing, write Heath Co.,
Dept. 016-632,
Benton Harbor, MI 49022

Heathkit Products are also sold and serviced at Heathkit Electronic Centers (units of Veritechnology Electronics Corporation) in major cities throughout the U.S. See your white pages.

The **Air Bed**®
Original
Velveteen

A Revolutionary Sleeping Experience

\$ **49**⁹⁵
from



The lightweight Air Bed offers a revolutionary sleeping experience. Gently, but firmly supports you with 100% air. Features air coil construction with multiple controlled air chambers that hold your body evenly and independently.

Turns any room into a guest room. The ideal portable bed for holiday and vacation visitors...and it stores easily.

Take it camping, in your van, on your boat, in your summer home; sunbathe and float on it!

Available in twin, double, queen and king sizes. Inflates in minutes with most air pumps or canister vacuum. (High-power air pump available—optional.) Made of sturdy 20 gauge poly vinyl, cleans with soap and water. Repair kit and pump adapter included.

Don't be misled by imitations. Insist on the original, red velveteen The Air Bed. 10-day Free Trial. If not satisfied, return it within 10 days for refund. Order now!

CREDITCARD ORDERS **800-648-5600** Nevada Residents Call:
CALL TOLL FREE: **800-992-5710**

OPERATOR NO. 48. 24 HOURS A DAY, 7 DAYS A WEEK
790 Maple Lane, Bensenville, Illinois 60106

Contemporary
Marketing, Inc.

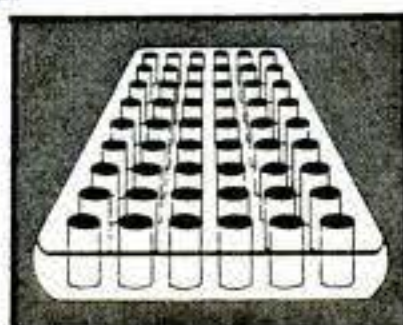

Air Coil Construction

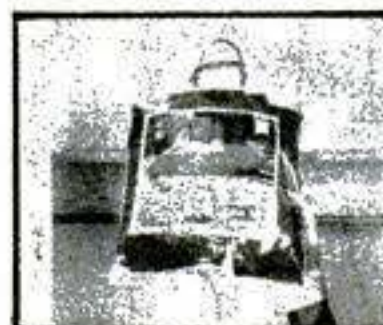

Stores Easily on Shelf

Please send me the following AIR BED(S):

Twin Size (Item 2339) \$49.95
 Double Size (Item 2354) \$69.95
 Queen Size (Item 2360) \$79.95
 King Size (Item 2374) \$99.95

Add \$4.95 per bed for shipping and insurance.

AC Air Pump (Item 0004) \$29.95
 DC Pump-12 volts-(Item 0005) \$29.95

Illinois Residents include 5 1/4 % sales tax.

Check/M.O. Enclosed Charge My Credit Card:

Master Charge American Express Carte
 Visa Diners Club Blanche

Card No. _____ Exp. Date _____
Name _____
Address _____
City _____
State _____ Zip _____
Signature _____

Contemporary Marketing, Inc.
790 Maple Lane, Bensenville, IL 60106
Dept. PSM0-060 © CMI1980251

Satellite TV

[Continued from page 123]

makes the satellite-TV service highly reliable.

If your site is suitable, you'll need to buy—or put together—a few components to get a functioning TVRO. The first, of course, is the antenna. Shaped like a dish, the parabolic antenna acts like a large concave mirror. Its reflector surface can be solid metal, a fine screen mesh, or a special fiberglass resin embedded with finely ground metallic particles. When directed at the satellite, the antenna captures the bird's relatively weak microwave signals and focuses the energy onto a smaller, feed-point antenna at the dish's focal point.

How big must the backyard antenna be? With our present generation of low-power domestic satellites, anything smaller than three meters (10 ft.) in diameter is apt to produce snowy or low-quality pictures. Most private installations have three-meter antennas, and at least one supplier (Channel One—see manufacturers' list) suggests a five-meter (16 ft.) antenna for parts of the country that are at the outer fringes of the satellite's main "footprint" (see map).

The second element of a TVRO is a sophisticated signal booster that connects directly to the feed-point antenna. Called a low-noise amplifier (LNA), the booster is needed because satellite signals are very weak and very susceptible to noise from electronic receiving equipment. To insure that no electronic amplifier noise degrades the signals, the LNA has a special gallium arsenide field-effect transistor that can amplify the weak microwave signals without adding much noise.

Double signal conversion

Once amplified, the signals are carried indoors (via coaxial cable) to the actual receiver. More like a "translator" than a home TV receiver, this unit converts the 3.7 to 4.2 gigahertz microwave signals from the satellite down to a much lower frequency, then reconverts them to a signal that can be received by a monitor. This double conversion is necessary because the technical standards for satellite television differ widely from our regular TV standards. Satellite-TV signals are FM (frequency modulated), while conventional TV broadcasts are AM (amplitude modulated).

You need a monitor to view the converted signal because satellite-TV receivers have no picture tube or speaker. Or you can view the satellite programs on your regular home receiver,

Continued

24 inch Band SAW CUTS TO CENTER OF 48 inches

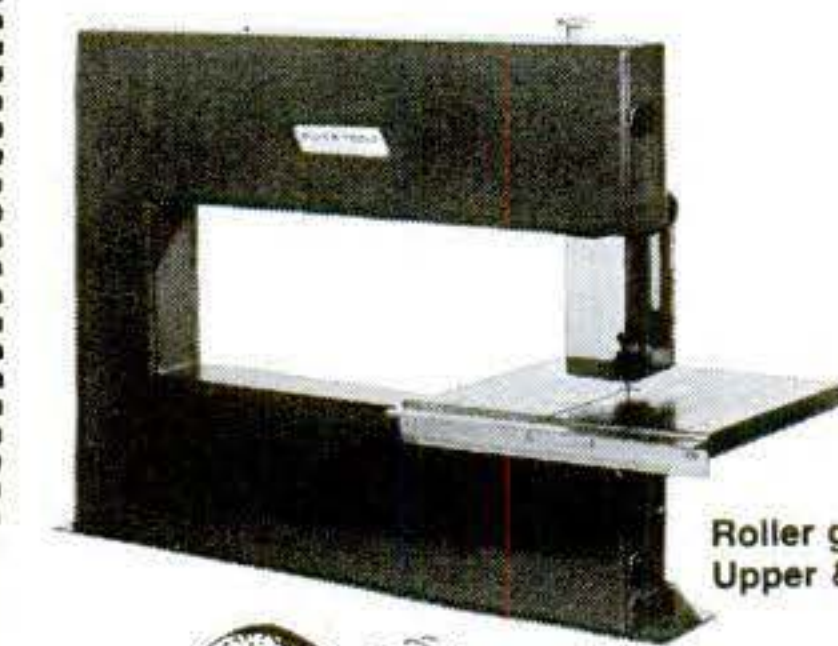

Roller guides
Upper & Lower

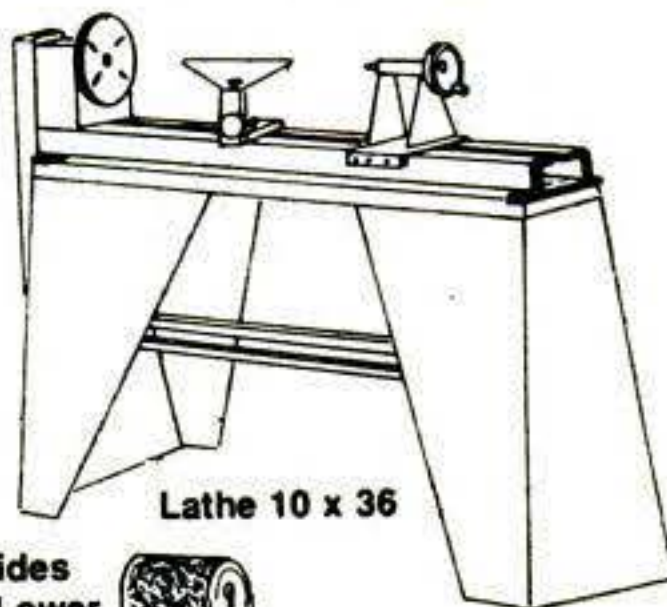

Lathe 10 x 36



1 inch Strip Sander
Completely enclosed



10" Disc Sander

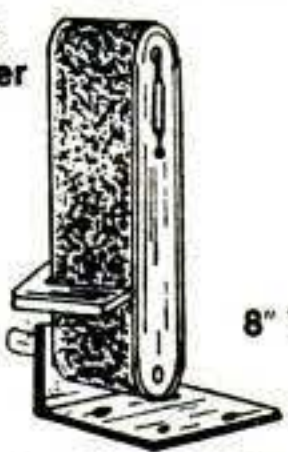

8" Tilting Arbor

3 & 4 inch
Belt Sander.

A FULL LINE OF RUGGED ALL STEEL TOOLS:

| | | |
|---------------------------------------|-------|--------|
| 24 inch Band Saw | | 199.95 |
| 12 inch Band Saw | | 159.95 |
| 10 x 36" Rugged Lathe Ball Bearing | | 89.95 |
| 3 inch Belt Sander Ball Bearing | | 24.95 |
| 4 inch Belt Sander Ball Bearing | | 39.95 |
| 8 inch Tilting Arbor Saw | | 99.95 |
| 10 inch Disc Sander Table Model | | 69.95 |
| 1 inch Strip Sander | | 69.95 |
| Deluxe Stand for all Tools | | 39.95 |

DU-ER TOOLS — RUGGED ALL STEEL — BALL BEARING — EXTRA VERSATILITY

Du-er's 24 inch Band Saw gives the handyman the versatility of an industrial tool at a price he can afford, the quality that is demanded by industry. The Band Saw, one of the best cutting principals for wood, metal or plastic, has been limited in use because of the depth of throat. The B-24's Big throat and new drive feature gives longer blade life, cuts metal, wood or plastic.

Du-er tools are fabricated of Heavy Gauge Steel, 30 years experience developed new engineering features with accuracy, and ball bearings for added quality. Extra features created by manufacturing know how makes Du-er tools available at exceptionally low prices, yet no quality is sacrificed.

You can order direct from Factory where there is no Dealer represented ... Free Information. F.O.B. factory

DU-ER TOOLS, 5448 Edina Industrial Blvd., Minneapolis, Minn. 55435.PS3

LIQUIDATION AT FAR BELOW DEALER COST!

Rockwell 16" EXTRA POWER LAWN TRIMMER

FACTORY NEW! FACTORY PERFECT!

Torque booster switch doubles the power to a full .8 hp. that manhandles your toughest weeds!

MODEL
7380

Adjustable auxiliary handle slides up, down, around the shaft for maximum comfort in all cutting positions!

LISTED

DUAL POWER MOTOR:
Normal power for regular trimming; extra power for edge trimming and tough weeds!

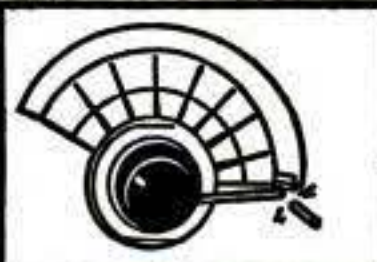

Powerful 5 amp. motor develops .40/.80 hp.

Automatically trims cord for operating ease!

Sturdy guard for operator safety; helps prevent accidental cutting of flowers and shrubs!



Line feeds automatically! Tap head to the ground; spool delivers fresh line.

Big 16" diameter cutting swath!

Spool holds 40 ft. of .080 line.

Famous Rockwell Quality!

All factory new, factory perfect! Rockwell decided to stop making Lawn Trimmers. But they will still honor all sales with a 1 year warranty on parts and labor. We slashed the price drastically on this inventory to liquidate them FAST at a HUGE SAVINGS to you!

Normal Retail: \$62.00
OUT THEY GO AT
\$28

Mastercharge, VISA, American Express members can phone in their order for convenience.

Toll-Free: 800-328-5082

In Minn. call collect: 612-729-2345



**C.O.M.B. Co. / Authorized Liquidators Dept. B-18
3258 Minnehaha Ave., Minneapolis, MN 55406**

Send Rockwell Lawn Trimmers at \$28.00 each plus \$4.50 each for shipping, handling. (Approx. 2 weeks delivery. Add extra 2-3 weeks if paid by personal check.)

My check or money order is enclosed.

Charge to my: VISA Mastercharge Am. Express
Acct. No. _____ Expires _____

PLEASE PRINT CLEARLY:

Name _____
Address _____
City _____
State _____ ZIP _____
Phone _____

MUST LIQUIDATE BELOW MANUFACTURED COST! \$2,150,000 INVENTORY ELECTRIC AIRLESS PAINT SPRAYERS

6 MONTH FACTORY WARRANTY!

From Sherwin Williams,
the LARGEST paint company in the world!
Swiss made! Swiss quality!

All factory new! Factory perfect! It needs NO air compressor! Just plug it in to a 110V socket, pull the trigger and spray!

Sure you've seen paint guns advertised before at all kinds of prices. But this one — Flomatic — is really extra special! It's made for a division of Sherwin Williams... largest paint company in the world! And who can know more about painting than they do? They wanted an excellent paint gun so they chose famous Swiss engineering. Swiss precision and Swiss quality. But excessive devaluation of the U.S. dollar made it too costly to continue producing more sprayers. So they cancelled the entire project. Now you can buy one at an amazingly low liquidation price!



The multi-purpose sprayer. Ideal for farm and home use!



 LISTED 932E



Spray oil on farm machinery as a rust inhibitor or to lubricate hard-to-reach parts.



The handy way to spray fertilizer or insecticide solutions on flowers, plants, shrubbery.



Ideal for fussy jobs like shutters, furniture, radiators, etc.



Perfect for repainting your car, truck, van farm vehicles.



Great for rough surfaces like bricks, stucco, concrete, etc.



Simple, fast for big jobs like a house, barn, garage.

Faster than a brush, roller or air sprayer! (And up to 30% paint saving over an air sprayer.) No bulky compressor to lug around. Just plug into 110V outlet. The powerful little motor sprays a wide variety of liquids at high rate of speed for fast, smooth coverage and a professional looking job! Simple cleanup and easy maintenance, too.

- Simple to use! Just turn a knob to adjust for large or small spray pattern. You get smooth performance!
- Two hardened steel jet nozzles. One for thin liquids such as stains, varnish, enamel. The other for heavier liquids such as latex, sealers, anti-rust paint, etc.
- High volume delivery from 1-qt. rugged plastic container. Up to 10 1/4 oz. per minute. Big jobs like a house get done fast and easy, without excessive overspray.
- Hardened steel cylinder and chromium plated piston for smooth operating efficiency.
- Gun body of cast aluminum with 10% silicon. Tough and rugged! Unharmed by solvents.
- High power pump section can be easily replaced.
- Cleanup is easy! Just spray the recommended solvent for whatever you were using through Flomatic.
- Includes 8-ft. heavy duty electric cord with ground wire. Plugs into 110V outlet.

IT'S MULTI-PURPOSE!

Use with latex, primer, varnish, stain, wood sealer, lubricating oil, auto enamel. Spray insecticide, weed killer. Apply liquid wax onto floors. Spray liquid fertilizer on flowers, shrubs. Or spray wax on cars, trucks.

Visa, Mastercharge, American Express can order by phone. Toll-Free: 800-328-5082. In Minnesota, phone collect: 612-729-2345.

Regular Retail:
\$119.95

Closeout price now only:

\$47

**C.O.M.B. Co. / Authorized Liquidators Dept. B-19
3258 Minnehaha Ave. S., Minneapolis, Minn. 55406**

Send Paint Guns at \$47.00 ea. plus \$3.00 ea. ship, handling.

My check or money order is enclosed.

Charge my credit card: VISA Mastercharge Am. Express
Acct. No. _____ Expires _____

PLEASE PRINT CLEARLY

Name _____
Address _____
City _____
State _____ ZIP _____ Phone _____

C.O.M.B. Co.

THE NATION'S LARGEST AUTHORIZED MAIL
ORDER LIQUIDATOR OF CONSUMER PRODUCTS

3258 MINNEHABA AVENUE SOUTH
MINNEAPOLIS, MINNESOTA 55406

Phone: 612-729-2345

Toll-Free: 800-328-5082

Copyright 1979 C.O.M.B. Co., Inc.

Copyrighted material

"...there's no better way to go motoring and pedaling too."

Auto Editor, Popular Mechanics

The Auto Editor of Popular Mechanics Magazine evaluated the BikeBug as an alternative to mopeds ... and his choice was the BikeBug! His two-page Product Report, (Dec. '77), was based solely on quality, design and performance. Price was never a consideration, even though mopeds cost hundreds of dollars more (Complete reprints with our free brochures).

The BikeBug engine and front-wheel-drive unit bolts in minutes to the front fork of any bike, from 10-speeders to adult tricycles. It runs up to 24 mph, gets 215 mpg, operates quietly, starts automatically, has a One-Year Warranty, and allows normal pedaling, even with the engine running.

For superior all-round performance, regardless of price, it's the BikeBug. And Popular Mechanics agrees.

AquaBug International, Inc.

Dep't PS83 100 Merrick Rd., Rockville Centre, N.Y., 11570 • (516) 536-8217



Name _____ Please Rush Me: Free Brochures.
 Address _____ A BikeBug: \$175, plus \$10 Shipping costs.
 City _____ MASTER CHARGE BANKAMERICARD/VISA
 State _____ Zip _____ # _____ Exp. _____
 (N.Y. Residents add tax) Check Cashier's Check Money Order

Satellite TV

[Continued]

but you have to add a modulator to the system (see diagram). This unit broadcasts the signals to an unused TV channel that can be tuned in on your home TV receiver—or receivers. You can connect a houseful of regular TV receivers to the satellite system through the modulator. In fact, without too much tinkering, dozens or hundreds of receivers in an area can be interconnected to the same satellite receiver through low-cost, uncomplicated coaxial-cable techniques.

How to plug in

There are three main ways to wire your home for satellite. If you're so anxious to have the service that you can't bear the thought of spending 50 to 100 hours rounding up the parts and building the system yourself, you can purchase a terminal on a turnkey basis, professionally installed where you want it and connected to your television receiver. (A list of firms supplying that service appears at the end of the article.) But be prepared to spend at least \$10,000 for just one-channel reception. The price rises as you add more channels (either by adding more receivers or buying an advanced tunable receiver); commercial equipment and installation time come high.

You can also buy the major hardware (antenna, LNA, receiver modulator, and cables) for between \$5000 and \$7000 and do the installation yourself. This means preparing the antenna's concrete base, erecting the antenna, and wiring the components together. It will take you and a husky friend about 20 hours to go from packing crates to television picture, and will cost at least \$7000.

The real challenge—and the cheapest way—is to do it all yourself. You no longer need an extensive microwave background to build your own TVRO. There are antenna kits available along with partially assembled receivers with prebuilt modules that you can lash together. There are also manuals telling you how to put all the electronics together from raw boxes of resistors, capacitors, and transistors (see list). Doing it yourself, either from preassembled modules or from scratch, pulls you down into the \$500–\$2500 price range. Needless to say, the more you do yourself, the less it costs.

Aiming the dish

Once you've set up your antenna, where do you point it? This depends on where you live, and what programs

Continued

Rare TECHNICAL INFORMATION!

If you're one of the select few people who have a need for hard-to-find "how-to" technical data, you should have this free catalog. You'll find the newest and most unusual collection of pamphlets, manuals, paperbacks, textbooks, industrial handbooks, and engineering references on lathes, machine tools, foundry, blacksmithing, electric automobiles, solar, wind and water power, methane, steam engines, hydraulics, compressed air, Savonius rotor windmills, welders, refrigeration, distillation, diesel repair, small business, three-phase motors, and much, much more! All publications guaranteed! New catalogs being issued regularly — available *only* by mail. If you have a genuine need for rare information, write directly to me for a free copy. But do it soon!



LINDSAY, BOX 12-AH, BRADLEY IL 60915

The Trimmer Your Barber Swears Doesn't Exist.

Just \$3.75

Why should he tell you about a product that could save you hundreds of dollars in barber fees every year? The SABO 4-in-1 Hairtrimmer lets you cut, contour, trim and style wet or dry hair to barbershop perfection. Yet it's almost as easy to use as a comb . . . no training or special skills required. Millions of people all over the world swear it's the best product of its kind. Convenient pocket size tucks into purse, suitcase or glove compartment for quick on-the-go touch-ups. The SABO Hairtrimmer . . . so good it pays for itself the very first time you use it. Order today! Our MONEY-BACK GUARANTEE means you try the SABO Trimmer at our risk. \$3.75 Additional Blades: 10 for \$1.50

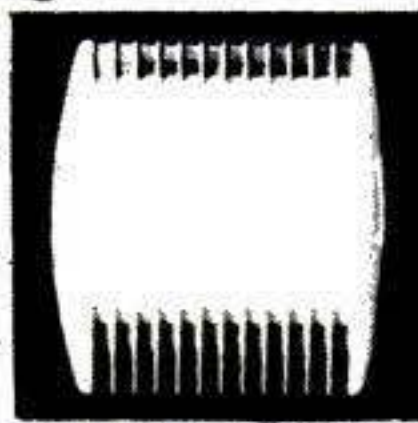

FREE: Order today and receive a genuine leather slip-case absolutely free!

PENN IMPORTS
P.O. BOX 4645
PHILA., PA 19127

Please rush _____ SABO Trimmer(s) @ \$3.75 e.
 Also send _____ pkgs. additional blades @ \$1.50 e.
 PA residents add 6% sales tax.

Name _____
 Address _____
 City _____ State _____ Zip _____

TURN SAND & CEMENT INTO \$100.00 A DAY

EARN BIG PROFITS—Over \$20 an hour—by manufacturing Colorful concrete Bar-B-Cues—Right in your own back yard or garage. Full or Part time. All materials available from local building supply. We offer a complete business package—For a Small Investment



Demand for outdoor barbecues now growing by leaps and bounds...and the BIG PROFITS are yours for the asking. Act now. Get full information

RPT MFG. Dept. PS-30 3537 Limekiln Pk., Chalfont, Pa. 18914

3PS80

Introducing...

The Fresh-Air Phenomenon

Guaranteed to...

Control Odors And Clean Your Personal Environment

CAIRFree* has been tested by the Environmental Protection Agency and was found to meet all government and FDA regulations.

U.S. Government Patent No. 3,925,673



listed by 

Now, through this exclusive scientific breakthrough, indoor air can be purified in exactly the same way outdoor air is purified by lightning during a thunderstorm.

Think of that sweet "country fresh air" smell following a thunderstorm. That's actually the absence of odor plus the introduction of additional forms of oxygen in the atmosphere. The electrical activity in the air created by lightning adds charged electrons to each oxygen molecule in the air. Science has long recognized the miracle of this phenomenon known as *ionization*. Amazingly, these ionized molecules combine with any odor-bearing molecules in the air—destroying them.

The CAIRFree Air Freshener's patented process electrostatically creates these same charged oxygen molecules that permeate any enclosed space and attract odor molecules like a magnet until they're totally "neutralized."

BEFORE CAIRFree

There were two ways to control odors: *Dilute*—constantly recycle fresh air to dilute odor molecules or *deodorize*—constantly mask odor with a heavy perfumy scent. Now, with CAIRFree, there's a third, more effective and highly scientific way. And that's to *destroy* all organic odor molecules electronically.

WHAT THE CAIRFree IS NOT

It's not a one-shot cover-up. It doesn't mask odors—it destroys them electronically. And it kills tough odors *continuously*—not temporarily like sprays, wicks, stick-ons, etc. There are never any chemicals to buy, bulbs to burn out or filters to replace. The unit uses only as much electricity as a 25-watt light bulb.

WHAT IT IS

The CAIRFree is a *continuous* air-cleansing process so unique it's patented. It uses the latest in space-age electronic technology to create the first energy and cost-efficient air purification system for the home. Even in a smoke-filled room, you will be breathing only clean, fresh air all day long.

FORCED AIR—THE MOST IMPORTANT NEW FEATURE INNOVATION

One of the secrets of this new system is that it keeps the ionized air in *constant motion*. The CAIRFree is the *only* electronic air freshener that *continuously* "pumps out" ionized oxygen molecules into the air, permeating every square inch of space—ready to attack and deactivate any odor-causing molecules instantaneously. Keeping the ionized air circulating is such an important factor that so-called "space age" air fresheners without it are truly outdated. Without it, odor-killing molecules simply fall to the ground near the unit, rendering them useless against odors.

A DUST-FREE ENVIRONMENT: AN UNEXPECTED BONUS

The CAIRFree also de-activates dust particles suspended in the air. The ionized oxygen pumped into your room will attach itself to any impurities in the air, causing them to fall to the ground. Ahhhh... what's left is pure, clean air.

PROVEN EFFECTIVE IN HOSPITALS, FISH MARKETS, PET SHOPS & HOTELS

Prior to this special introduction to consumers, hundreds of CAIRFree Air Fresheners were used by businesses with their own peculiar odor problems. After using it for over 8 months they found it to be the only answer to annoying, persistent odors. Why? Because it outperforms other systems in what it does and how it does it.

TO USE IT IS TO LOVE IT

You will feel the difference immediately. The CAIRFree will cleanse any 20' x 20' room of odor-causing molecules within just 5 minutes! Imagine how exhilarated you'll feel with a fresh supply of ionized oxygen surrounding you day and night!

CLEAR THE AIR ONCE AND FOR ALL

In the kitchen...bathroom...basement...nursery...pet areas...smoke-filled offices. Use it anywhere stale, musty, offensive or pungent odors are a problem. The attractive white unit is compact—10" x 6" x 4" deep—and lightweight—only 8 pounds. It can be wall mounted as an inconspicuous permanent fixture where annoying odors tend to accumulate. Or, it can be moved from place to place as needed, taking up little space on a shelf or counter top. And installing it is simple—just plug it in. It uses regular household current.

LET YOUR NOSE PROVE ITS EFFECTIVENESS IN YOUR HOME OR OFFICE

The CAIRFree may sound too good to be true. That's why we offer a 30-day trial period and ask you to really give it a workout. For starters, simply turn the unit on, then cut up a big, juicy onion. No tears. No smell.

SOLIDLY BACKED

If anything goes wrong with your unit during the first year Environmental Electronics Corporation will repair it—without charge. Although the CAIRFree Air Freshener is built to last and be virtually maintenance free, it's still nice to know the manufacturer is service conscious.

SPECIAL INTRODUCTORY PRICE

The CAIRFree is manufactured in America for Cambridge International by EEC. We are offering this exciting new product directly to our customers exclusively through the mail for only \$129.95 during our national introduction. Order one at no obligation today.

*CAIRFree, formerly advertised as the Environ-Aire, has been re-styled to complement the home decor. The CAIRFree Air Freshener employs an electrostatic air filter system, ionized oxygen and other forms of oxygen to scrub the air clean.

CAMBRIDGE INTERNATIONAL, Inc.

Dept. P30
8700 N. Waukegan Rd.
Morton Grove, ILL. 60053
(312) 966-5510

Credit Card Customers

**Call Toll Free
800-228-5440**

(In. Neb. 800-642-8777)

24 Hrs. A Day—7 Days A Week

- Please rush me _____ CAIRFree Air Freshener(s) at just \$129.95 plus \$6.95 shipping & handling. (Ill. residents add 6% tax).
- Save at least \$30.00! Send _____ 3 or more units at \$119.95 each plus \$4.00 each shipping and handling.
- Check or Money Order enclosed.
- Charge to: Master Charge Diners Club
- American Express Carte Blanche Visa

Account # _____ Exp. Date _____
Name _____
Address _____
City _____ State _____ Zip _____
Signature _____

YOURS FREE!

**FEIRER
CABINETMAKING
AND MILLWORK**

**CABINETMAKING
AND MILLWORK**

Thousands of explanatory drawings illustrate important points and show you exactly how to do hundreds of woodworking jobs...

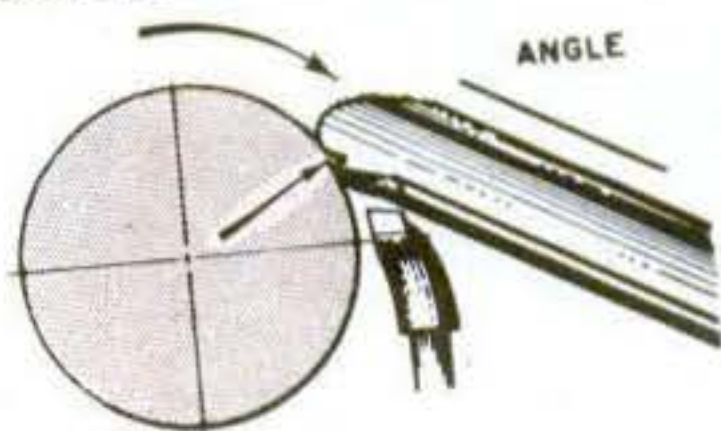

ANGLE

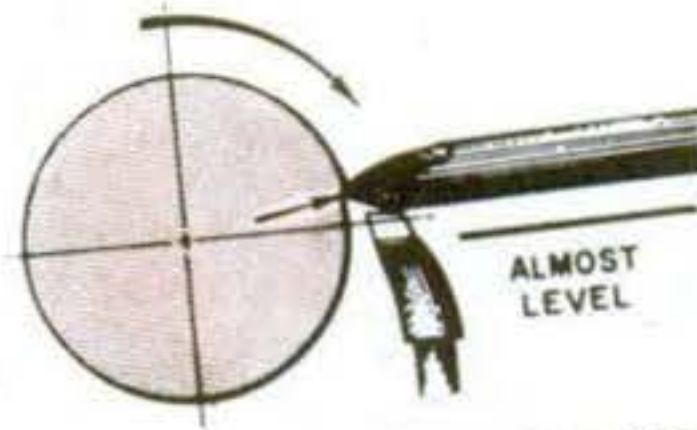

ALMOST LEVEL

The two basic methods of turning on a lathe: cutting (top) and scraping.

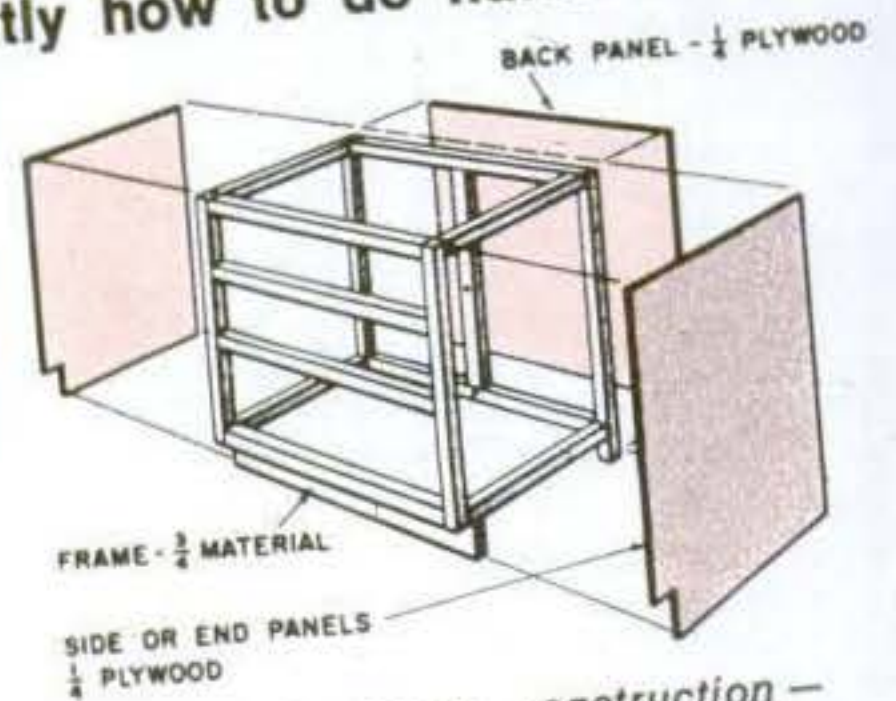

FRAME - 3/4" MATERIAL
SIDE OR END PANELS
1/2" PLYWOOD

This is frame construction - often used in kitchen cabinets.

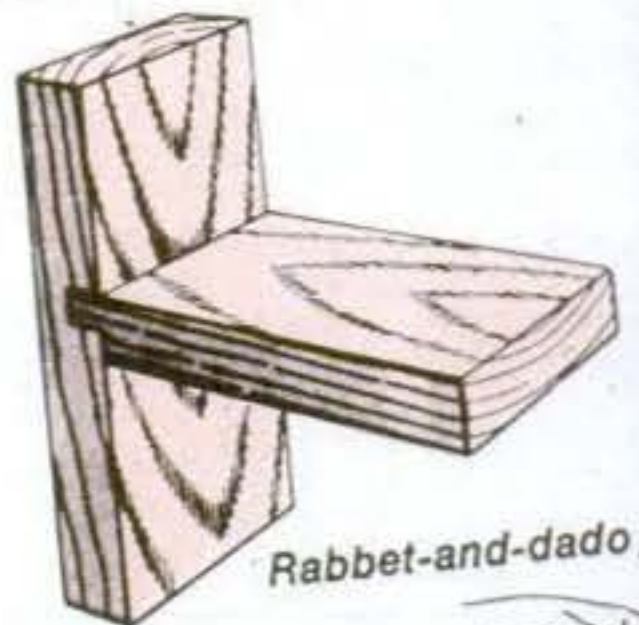

Rabet-and-dado joint.

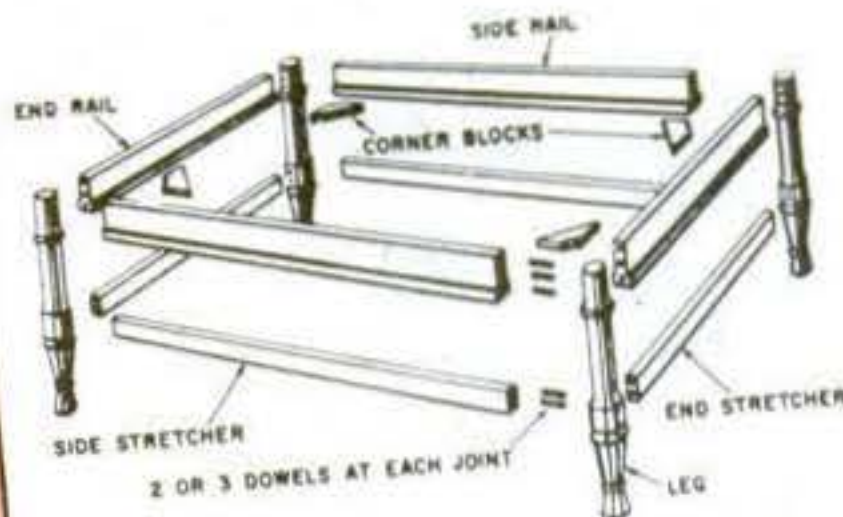

Exploded view of coffee table showing leg-and-nail construction using dowels and corner blocks.



When sharpening a hand saw, make sure the file is level as the stroke is made.

- ★ Master cabinetmaking techniques.
- ★ Become an expert at using hand and power tools—even lathes, routers, shapers.
- ★ Learn how to build furniture, do fine interior work.

- 928 PAGES
- THOUSANDS OF EXPLANATORY PICTURES

MAIL ATTACHED CARD TODAY OR WRITE TO:

Take this giant \$24.95 treasury of creative woodworking

FREE

when you join
Popular Science Book Club

If you're like most do-it-yourselfers, you probably do most of the routine woodworking jobs around the house yourself and *pay* to get the fancier work done. Yet the real satisfaction of woodworking comes from doing those fancy jobs yourself: making a wall of handsomely grained built-ins . . . wood-panelling an entire room . . . constructing a table with a perfectly matched veneer top. Yes, you can do all of these fancy jobs yourself *even without experience* when you've got a copy of **CABINETMAKING AND MILLWORK** as your guide.

Thousands of show-how pictures guarantee success!

This excellent, 928-page volume is a complete education in fine woodworking. It teaches you exactly how to do every step of every woodworking job you'll ever want to do. Thousands of explanatory pictures (including many full color photographs), charts, assembly drawings, finishing illustrations, construction details and more make this book very easy to use . . . *even for a novice!* (Think of the money you can save by building, repairing, finishing and refinishing all kinds of home woodworking projects *yourself!*)

Super clear how-to on tools, wood, construction, materials, finishing and much more!

CABINETMAKING AND MILLWORK is such a giant how-to book that it takes more than 1700 separate index listings just to tell you *where to look* for each step-by-step answer. You get more than 200 pages on how to use hand tools, power saws, shapers, routers, drills, boring machines, lathes and more, including how to sharpen and care for tools and make a variety of jigs for power tools.

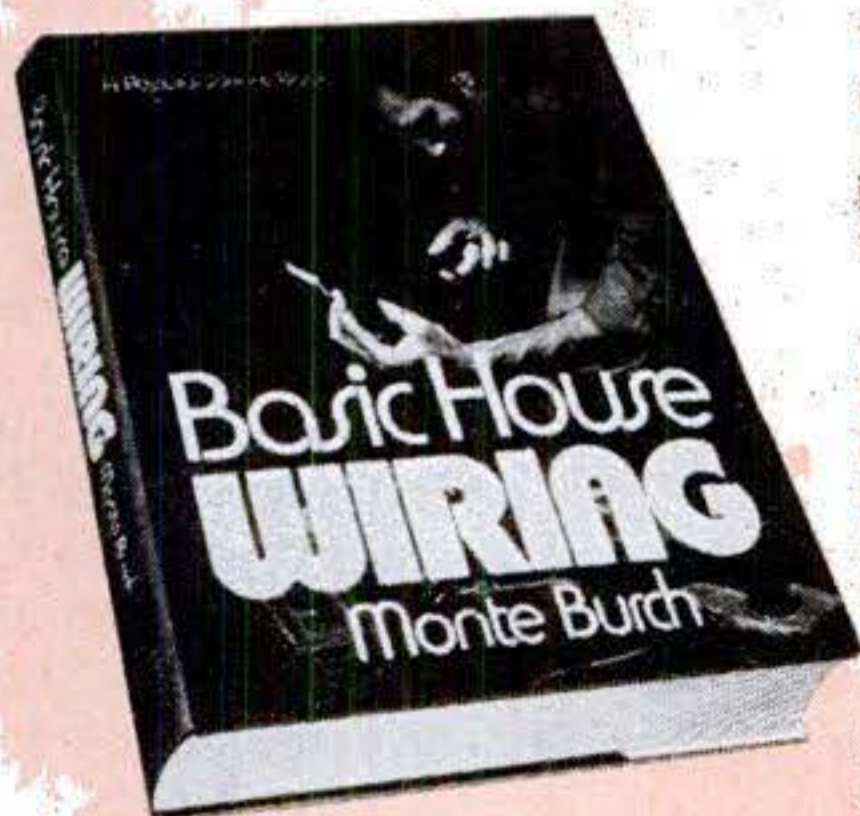

Your first Club selection is **BASIC HOUSE WIRING**

This excellent book was custom written especially for Popular Science Book Club. It tells you everything you need to know to install, repair, improve and troubleshoot the entire electrical system in your home.

How to determine wiring needs. How to draw up plans for "go-aheads". How to install complete systems. And how to wire low-voltage devices (intercoms, etc.), rural buildings, service entrances, workshops, heavy-duty machines, appliances—everything!

For example, how to rewire an old house inside and out. Hang a chandelier. Put in handy closet fixtures. Install dimmer switches, convenience outlets, three-ways. Set up an intercom. Install door chimes.

Ground your TV or radio antenna.

And this new book makes all these things easy. More than 500 illustrations guide you through each job step by step.

This is the latest, most complete book of its kind available. It regularly sells for \$12.50. Your PSBC price is only \$9.95 plus delivery and handling.

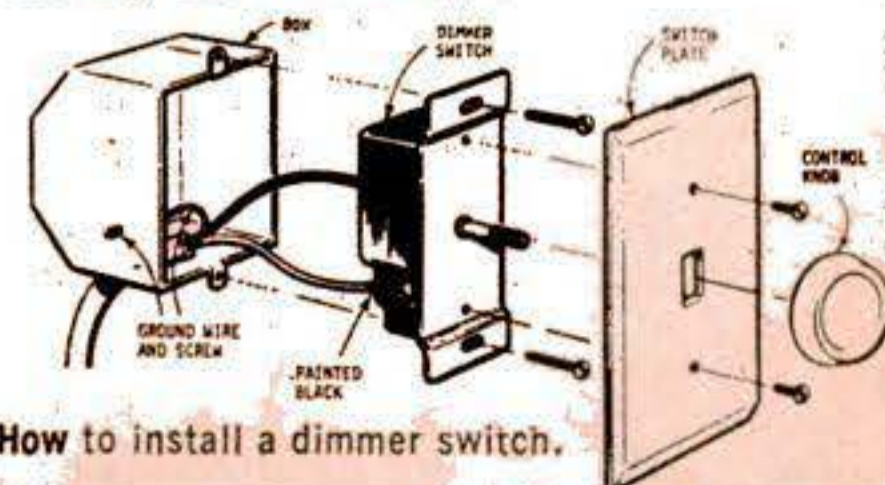

CLUB MEMBERSHIP SAVES YOU UP TO 50% ON THE BEST NEW DO-IT-YOURSELF BOOKS!

- home improvement and repair
- house building • cars and car repair • home workshop • appliance repair • electronics • how things work • protection • masonry and carpentry • mathematics • science and technology • space • more

More than 300 pages of specific construction plans for built-ins, kitchen cabinets, room dividers, tables, bookcases, furniture of every description. You even get a big wood finishing section with more than 100 pages of step-by-step how-to for all kinds of fine hardwoods and practical softwoods, plywood, composition, hardware, plastic laminates, etc. There's much, much more on how to read blueprints, how to make construction drawings, estimate costs, purchase materials at big bargains. Every detail you need to know is given the complete, clear-cut treatment in this excellent do-it-yourself book. You'll use it for years as one of your favorite "handyman's tools".

HOW POPULAR SCIENCE BOOK CLUB WORKS

- First, you get **CABINETMAKING AND MILLWORK** (regular price \$24.95) **FREE**, and your first Club selection, **BASIC HOUSE WIRING** (regular price \$12.50) for just \$9.95 plus delivery and handling. That's \$37.45 worth of books!
- Then, about every four weeks, 15 times a year, you'll receive a bulletin describing the main selection and alternate books also available. If you want the main selection only, do nothing. It will be sent to you automatically. If you don't want the main selection or want an alternate book, just indicate your wishes on the form that comes with the bulletin and return it by the date indicated. You will always have at least ten days in which to do this but in the unlikely event that you don't, and you receive an unwanted selection, you may return it at our expense. In addition, you may return any book within ten days, after examining it, if you're dissatisfied with it.
- After receiving your joining shipment, your only obligation is to buy two more regular selections or alternates in the next year. After that, membership may be cancelled at any time, by either you or the Club.
- You save up to 50% on every selection. Yet virtually every book is identical to the publisher's edition. Same binding, paper, print, jacket. Same everything except price.

POPULAR SCIENCE BOOK CLUB, P.O. Box 2006, Latham, N.Y. 12111

SLEEP LIKE YOU'VE ALWAYS DREAMED OF...

On a Siesta Air Bed!

The new improved air bed

Inflates in minutes for
luxurious comfort anywhere!

- Camping
- In your Car or Van
- On the Boat
- By the Pool
- In the Guest Room

The sensuous way to sleep

Siesta Air Beds provide you with the relaxing, sensuous sleep of a water bed without the fuss and weight! Their revolutionary Tubular Air Coil System automatically equalizes body weight so you don't "sink" and sides won't pop up. Your whole body gets the firm yet gentle support it needs to wake up feeling alert, rested, restored!

Improved! Lush, denim-like finish

Unlike other air mattresses you may have seen, the Siesta Air Bed is luxuriously covered with a soothing denim-like Rayon that never feels cold or slick. You'll enjoy complete "at-home" comfort even when you camp out on vacation!

Outstanding durability, too

The Siesta Air Bed is unbelievably strong—kids can jump and play on it without wear and tear. It's double-sealed by the manufacturer for long, leak-proof life... Siesta's are really built to take it. So, you can take your Siesta along wherever you go and get the sleep you need.

Like having a guest room on a shelf

No place to put up guests? No problem when you own a Siesta Air Bed! Just inflate it in minutes and provide guests with a luxurious "guest room" anywhere. When they're gone, just deflate it and store it easily on a small shelf! But you may well decide to make your Siesta Air Bed your permanent mattress. No frame or box spring is required—the Siesta is the all-in-one luxury bed for comfort and unprecedented convenience at home or on the road.



Store your Siesta "Guest room" on a shelf when not in use! Inflate it in minutes when guests arrive—or use it every night for a deep, restful sleep.

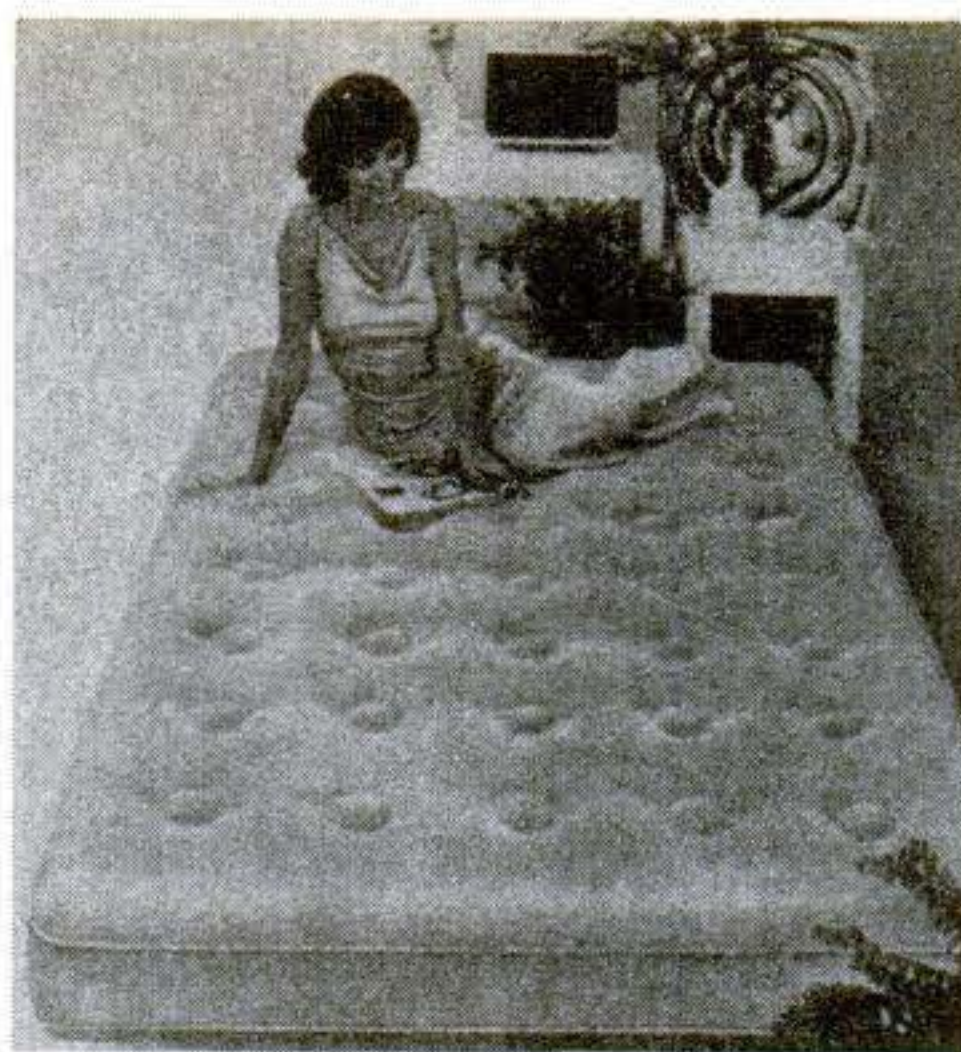

Sleep FREE for 30 nights!

We invite you to sleep-test a Siesta Air Bed for a full 30 nights before you decide a thing. If not convinced that it gives you the most restful, supportive sleep ever, simply return it for a prompt, complete refund.

Available in a variety of sizes

Whether you order Full, Twin, Queen or King, you'll enjoy the sleep of a lifetime! And don't forget to order the Custom Air Pump specially designed for use with the revolutionary new Siesta Air Bed.

Order Now at these low prices!

A fine mattress has become a very expensive proposition—but not the Siestas! You may own a Twin-size Siesta for just \$59.95, a Full for \$79.95, a Queen for \$99.95 and a King-size for merely \$109.95 plus \$5.95 for shipping and handling—incredible! The Custom Air Pump is just \$29.95.

**CAMBRIDGE
INTERNATIONAL, Inc.**

8700 Waukegan Rd. Morton Grove, IL 60053 (312) 966-5510

Credit Card Customers

Call Toll Free
800-228-5440

(In Neb. 800-642-8777)

24 Hours A Day—7 Days A Week

Clip & Mail To:

Cambridge International, Inc. Dept. P30
8700 Waukegan Road, Morton Grove, IL 60053

Please send me the following Siesta Air Bed(s). I understand that I may return my purchase within 30 days for a full refund.

- Twin @ \$59.95 Full @ \$79.95
 Queen @ \$99.95 King @ \$109.95
 (Add \$5.95 shipping and handling per bed)

Also send me the high-powered motorized Custom Air Pump @ \$29.95 each. (Ill. residents add 6% sales tax.)

Check or Money Order enclosed

Charge my Credit Card Account:

- American Express Master Charge Visa
 Diners Club Carte Blanche

Account # _____

Exp. Date _____

Name _____

Address _____

City _____ State _____ Zip _____

Signature _____

© Cambridge International, Inc. 1980

Satellite TV

[Continued]

interest you (see map). So far, RCA's Satcom I has the most programs available, and most people end up pointing their antenna at this bird. But other satellites may add more programming, so it's wise to consider selecting an antenna equipped with a "polar mount."

This will allow you to aim the antenna at different satellites—though you have to get out there and actually push the dish into position. A few clever people have motorized the polar mount simply because one never knows when the urge to watch a curling match from Canada or a bullfight from Mexico may strike.

But is it legal?

In October 1979, the FCC, which had required a license to install a TVRO, lifted that requirement. You can now set up a TVRO without any governmental permission, but be sure to check local zoning laws before erecting an antenna on your property. And in some areas, especially urban centers, the air waves are already heavily saturated with microwave transmissions, so you may have to do research to see if your installation will cause interference with these signals.

A murkier area is whether it's legal to pull in signals aimed at paying customers (the cable companies). Some program suppliers make it easy—they charge a "lifetime" fee. The new all-sports network ESPN, for instance, charges \$100. Other suppliers charge the retail price paid by regular pay-cable subscribers—Warner's all-movie channel costs customers \$96 a year, for example.

Some companies, such as Home Box Office, refuse to set a fee—they simply don't want any private individual tuning in their signals. In fact, HBO is considering installing a scrambler system.

But some TVRO owners feel that neither fees nor permissions are needed. Says one satellite-TV enthusiast: "As long as those photons are falling on my property, I can pick them up." Fred Hopengarten, president of Channel One, a turnkey supplier, cites the legal precedent of common carriers. In testimony before the FCC he argued that, since satellite signals are transmitted via common-carrier microwave frequencies, tuning them in is in the same category as tuning in police radio transmissions—perfectly legal.

But some program suppliers worry about copyrights. This again is a mur-

Continued

RUN YOUR CAR! — HEAT YOUR HOME!
USED AND PROVEN BY FOREIGN COUNTRIES, STATES
AND MUNICIPALITIES ALL OVER THE WORLD.



IT'S TRUE! NOW YOU CAN

Fuel FOR LESS THAN 15¢ A Gallon!

AND HAVE ALL THE FUEL YOU NEED, LEGALLY.

FASTER ACCELERATION • BETTER MILEAGE • HIGHER OCTANE
AND BEST OF ALL... YOU CAN MAKE IT RIGHT IN YOUR OWN BACK YARD!

■ From Nations' capitals all over the world comes exciting news of a fantastic breakthrough in fuel saving technology...a way for every American who owns a car or heats a house to beat the fuel shortage...and save thousands of dollars annually too! So successful, it has been road-proven in a two million mile test in one state alone.

The state of Nebraska, faced with the same fuel crisis that we all face, put this dynamic method to the test. They used this new fuel in staff cars, trucks, road maintenance vehicles, even state trooper cars (and you know the kind of punishment they take). These vehicles put in a total of two million miles. That's about 80 times around the world. The results? Just too remarkable to be true...but true it is. All vehicles got more miles to the gallon. Drivers reported **faster acceleration, greater engine response.** And the fuel itself measured a **higher octane rating** than premium unleaded gasoline.

The country of Brazil, (as reported in the NY Times), is converting all its cars to run on 100% alcohol...a product that they can produce from agriculture.

Running cars on Alcohol or Gasahol (alcohol and gasoline mixture) is not a new idea. The big Indianapolis racing cars have been running on "alki" for many years for these very same reasons: **better mileage, faster acceleration, cleaner burning engines, and at least four octane points higher than the premium unleaded** now available (when you can get it).

Gasahol is an amazing fuel that has been known to scientists for years. Now, through advanced technology, you can make this fuel yourself. See details in fact filled book.

HEAT YOUR HOME...RUN YOUR CAR
But, the greatest advantage of all...the one biggest hope for car-dependent America is... **you can make this fuel yourself!** That's right...you can make all the fuel you want for your car - boat - truck - tractor...even make fuel to heat your home this winter. YES! Even make fuel to heat your home. Think of that when home heating oil goes to \$1 a gallon (if you can get it), and you're begging for delivery. Stop being dependent on the big oil company monopolies. Make your own fuel...do it now... have all you need!

DO-IT-YOURSELF FUEL STATION
If you're fed up with the way gas companies

have been treating you, with the long lines to fill up, with the artificially high cost of fuel, of being ripped off by the oil cartels...well, here's your chance.

DO SOMETHING ABOUT IT!

We'll show you how to make fuel from vegetables and other crops, from grass clippings...even garbage. And the whole operation can run on solar power so you don't use fuel to make fuel. We'll give you plans for a solar furnace you can build for under \$15. We'll even supply the application for the Federal License. (the U.S. Government is allocating billions of dollars for alternate energy sources research. The Government encourages the making of this fuel by repealing the 4% Excise tax on Alcohol Fuel).

G.M., CHRYSLER, FORD

Even the big three car makers, General Motors, Chrysler, Ford say that the use of Gasahol would **not void their warranties.** In fact all new autos, even Volkswagens exported to Brazil must run on 100% alcohol.

You can run your car on a 10% alcohol, 90% gasoline mixture right now, or you can make some minor adjustments and run your car on 100% alcohol.

Look, if you need your car to get to work, or you need fuel to power your truck or farm tractor, or to run a boat or for any gasoline powered engine, you can make that fuel yourself...easily, quickly, right in your own back yard. Remember, any engine that runs on gasoline can run on Gasahol. Take this opportunity to free yourself from bondage to the oil companies...order your book today!



FEATURED STORY AND USED IN N.Y. DAILY NEWS STAFF CAR

Gasahol...The Wonder Fuel: you've heard it on The Today Show, CBS Reports, Tom Snyder Show, read about it in newspapers and magazines. ©1979 MEDIA MARKETING

SPONSOR MEMBER-NATIONAL GASAHOL COMMISSION

CHECK THESE ADVANTAGES:

✓ **GIVES YOU MORE MILES PER GALLON...WITH LESS TROUBLE TOO.**

✓ **HIGHER OCTANE. 4 TO 5 POINTS HIGHER THAN PREMIUM UNLEADED**

✓ **FASTER ACCELERATION, REDUCE EXHAUST EMISSIONS.**

✓ **BURNS CLEANER, MORE EFFICIENTLY THAN CONVENTIONAL GASOLINE.**

✓ **CAN BE USED STRAIGHT OR MIXED WITH GASOLINE.**

AND... NO LINES TO WAIT ON... YOU MAKE YOUR OWN.

FOR CREDIT CARD PURCHASE, CALL TOLL FREE 1-800-331-1003

COMPLETE BOOK \$9.95 ONLY

TWO FOR ONLY \$18.95

SATISFACTION GUARANTEED OR MONEY BACK

NEW FUELS, Dept. 953

283 Greenwich Ave., Box 464, Greenwich, CT. 06830

Please send me the new book on how I can make my own fuel at home. I understand that if I am not completely satisfied, I can return the book within 14 days for a full refund of product cost.

Fuel book only \$9.95 plus 75¢ shipping

Save: Two for only \$18.95 postpaid

Please make checks payable to: New Fuel

Enclosed is \$_____ (check or money order)

OR, you may charge it: Visa MasterCard

MC bank# _____ Exp. date _____

Acct.# _____

Name _____

Address _____

City _____

State _____ Zip _____

CT. RESIDENTS ADD SALES TAX

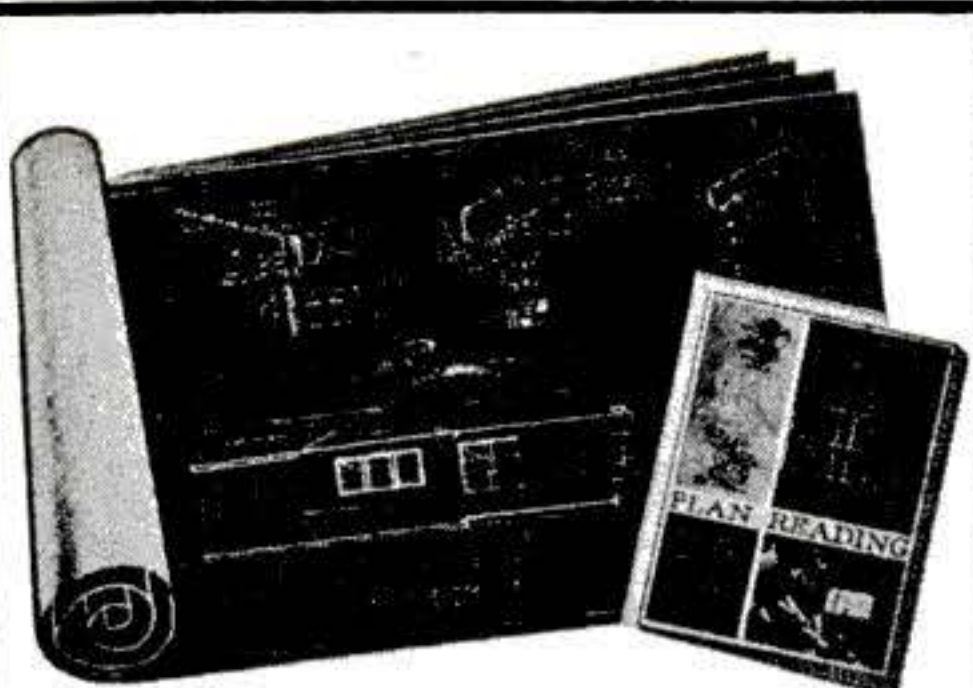

FREE BLUEPRINTS and TRIAL LESSON
 —for your greater success in Building

Beginners, craftsmen, even foremen and superintendents, have sent for these free blueprints and trial lesson in Plan Reading as a means of trying out Chicago Tech's home-study Builders training. Learn how you can master Plan Reading—Estimating—and the practical details of all types of construction in your spare time at home. Mail coupon below or phone TOLL FREE—see how you, too can prepare for a better job—higher income, or start your own contracting business.

● PHONE TOLL FREE (24 HRS.)
 1-800-528-6050 Ext. 810

CHICAGO TECH/School for Builders
 2000 S. Michigan Avenue, Chicago, Ill. 60616

CHICAGO TECH/School for Builders
 Dept. PS-30 2000 S. Michigan Ave.,
 Chicago, Ill. 60616

Veterans
 Check
 Here

Please mail me a Free Trial Lesson, Blueprints and Builders Catalog. I understand there is no obligation—no salesman will call.

NAME _____ AGE _____
 ADDRESS _____
 CITY _____ STATE _____ ZIP _____

HOW-TO
 A Money-Saving
 Troweling Tips Booklet

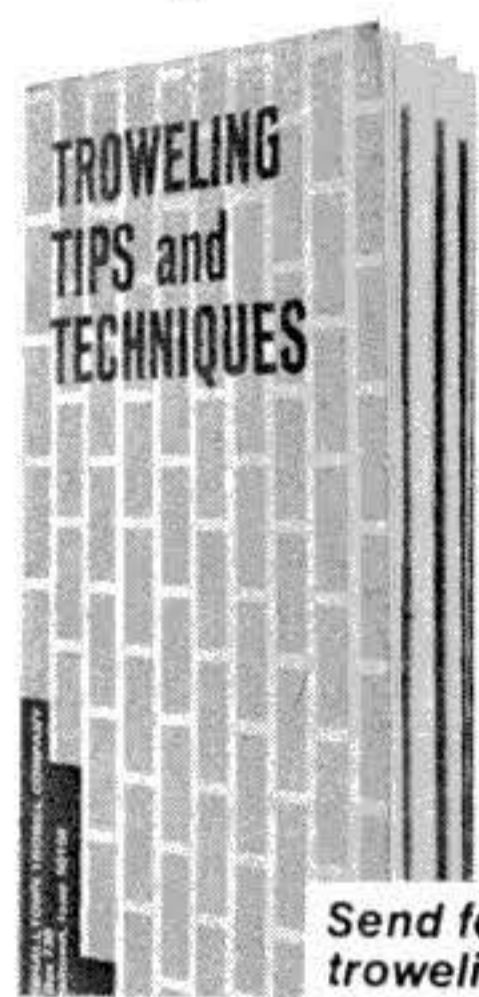

- 24-page illustrated booklet
- Easy to understand... save you time
- List of tools needed for each job
- Tips on cement, block, and brick work; plaster repair and dry wall
- Used by many vocational schools and training centers
- Just 75¢ (includes mailing)

Send for your professional troweling tips booklet today!

Enclosed is _____ for _____
 "Troweling Tips" booklets at 75¢ each.

Name _____
 Address _____
 City _____
 State _____ Zip _____

Send to:
Marshalltown Trowel Company
 104 S. Eighth Avenue
 P.O. Box 738 Marshalltown, Iowa 50158

Satellite TV

[Continued]

ky legal area. A recent California court case established an individual's right to videotape TV programs for private use—despite the copyright claims made by the program producers. The same precedent may apply here.

However the legal issue is resolved, home TVRO's are probably here to stay. According to Dr. Frank Roberts, a project scientist for Radio Shack, hobbyist TVRO's may be available for about \$1000 by late 1981.

Prices will drop even further when the new generation of more powerful satellites begins transmitting in the latter half of the decade. Already both Canada and Japan are experimenting with such satellites. Their strong, super-high-frequency (12 GHz) signals can be picked up by parabolic antennas smaller than a meter—and that's small enough to sit atop your TV set and look out the window. PS

For more information

If you want to learn more about the basics of a home satellite-TV reception system, a Satellite Study Package is available for \$14 (\$16 outside U.S. and Canada) from **Satellite Television Technology, Box 2476, Napa CA 94558**. The package includes a 72-page booklet and a large, two-sided map/chart.

Firms providing "turnkey" (i.e., fully installed) professional-grade satellite terminals at prices in the \$10,000—\$18,000 range include: **Channel One, Inc.**, 68 Avalon Rd., Newton MA 02168; **Homesat, Inc.**, 3845 Pleasantdale Rd., Atlanta GA 30340; **Gardiner Communications Corp.**, 1980 S. Post Oak Rd., Houston TX 77506; **Microdyne-AFC**, 627 Lofstrand Lane, Rockville MD 20850; **Satellite Television Systems, Box 11249, Reno NV 89510**; **USTC, Drawer S, Afton OK 74331**.

Two complete sets of construction plans designed for the serious satellite-TV enthusiast are also available. The *Howard Terminal* manual describes construction of a high-quality terminal from scratch; the *Coleman TD-2 Conversion* manual describes acquisition and conversion of surplus electronic equipment for satellite-TV reception. The manuals are \$30 each or both for \$50 from **Satellite Television Technology** (address above).

Coop's Satellite Technology Newsletter reports monthly on the rapid changes in satellite operations plus the evolution of low-cost satellite-television hardware. Subscription rates are \$50 per year (sample available for \$5) from **Box G, Arcadia OK 73007**.

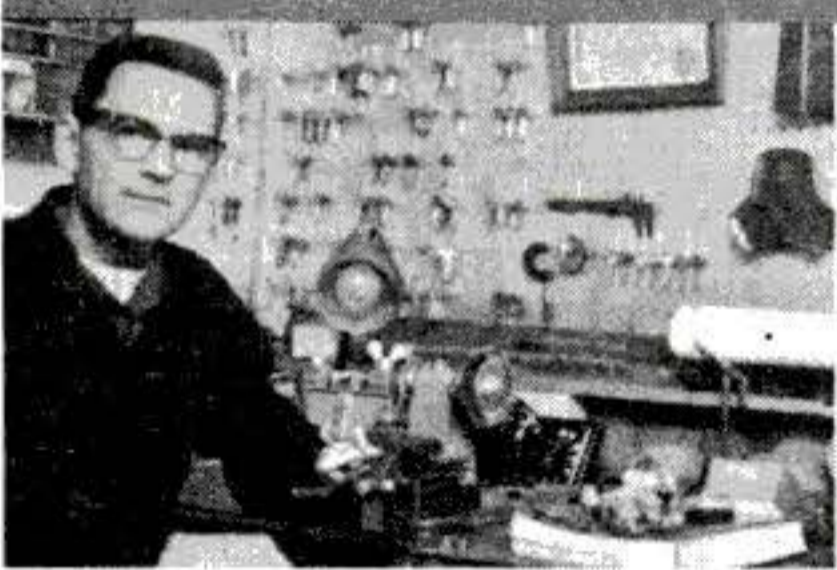

This VET Did It – and YOU Can Do It Too!

"War injuries left me badly handicapped, but now I'm a financial success as a Locksmith, thanks to your training. Besides, the work is fascinating. If I can do it anybody can." — Glen Johnson, Larned, Kan.

Make Up to \$10 an Hour—even while learning!

Train FAST at Home! **Be a LOCKSMITH!**

If you enjoy fixing things, you're a "natural" to make hundreds of EXTRA DOLLARS a year in the fascinating business of Locksmithing. Rising crime has increased demand for service a thousandfold. Yet there's only one Locksmith for every 17,000 people! **COLLECT CASH PROFITS ALMOST AT ONCE!** You're "in business" ready to make \$5 to \$10 an hour a few days after you begin Belsaw's shortcut training. Easy, illustrated lessons complete with ALL practice equipment **PLUS**

- ALL TOOLS YOURS TO KEEP
- KEY MACHINE YOURS TO KEEP
- EXPERT PERSONAL ASSISTANCE
- BUSINESS-BUILDING HELP

THIS DO-ALL PRO KEY MACHINE YOURS TO KEEP!

Can add \$25 to \$40 a week to your income... and doesn't cost you a penny extra!

enable you to get your share of this always-profitable business. Hundreds we've trained are doing it. So can YOU.

MAIL COUPON to discover how Locksmithing can keep the extra money coming in during spare time—or in your own full-time business. Ideal for retirement—good jobs, too.

BELSAW INSTITUTE, 110M Field Bldg.
 Kansas City, Mo. 64111
 Accredited Member NHSC.



- N. Hunt, Wilmington, Del.—"I make \$50 a week extra."
 R. Davis, St. Louis, Mo.—"I cleared \$110 last Saturday."
 Ed Boyle, Pittsburgh, Pa.—"My business going at top speed. I'm moving to bigger quarters."

FREE MAIL THIS COUPON • NO SALESMAN WILL CALL

BELSAW INSTITUTE, 110M Field Bldg.
 Kansas City, Mo. 64111

Rush FREE book, "Keys to your Future."

Name _____
 Address _____
 City _____ State _____ Zip _____



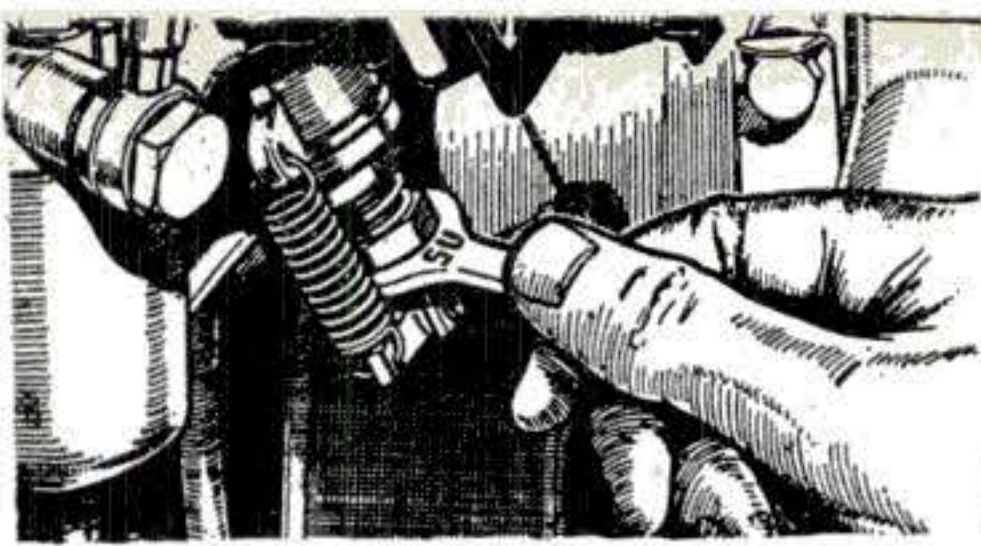

Know your car inside and out.

Know how to fix it... to tune it... to service it... to keep it running right. The **TOTAL SERVICE MANUAL** for your car will show you how to do everything from a minor adjustment to a major repair.

factory workshop manuals. Each one is carefully rewritten for use by the do-it-yourself car owner. Clear and easy to follow, yet complete and detailed enough even for professional use. You get all the important information plus hundreds of the best pictures, diagrams, and specifications.

TOTAL SERVICE MANUALS are digests of official SATISFACTION GUARANTEED OR YOUR MONEY BACK

| | | |
|------|--|---------|
| 1713 | ALFA ROMEO 62-78 for all Giulia, GT & Spider mdls | \$9.95 |
| 9641 | ALFA ROMEO ALFETTA 73-78 | \$9.95 |
| 9643 | AMC AMBASSADOR 68-74 covers all models | \$9.95 |
| 8677 | AMC PACER 75-77 covers all models | \$9.95 |
| 0991 | ARROW, PLYMOUTH 76-77 for all models | \$9.95 |
| 9404 | ASPEN, DODGE 76-78 for all models | \$7.95 |
| 7122 | AUDI 100 70-77 for all models inc 100L | \$9.95 |
| 0664 | AUDI 5000 77-79 | \$9.95 |
| 8749 | AUDI FOX 73-79 covers all models | \$17.50 |
| 0916 | AUSTIN AMERICA 68-71 covers all models inc 1100, 1300 | \$9.95 |
| 1203 | AUSTIN HEALEY 100/6, 3000 56-68 for all models | \$9.95 |
| 0752 | AUSTIN MARINA 71-75 sedan and GT models | \$9.95 |
| 0379 | BARRACUDA & CADA 65-72 all 6 & V8 models | \$7.95 |
| 0503 | BLAZER, CHEV 59-77 for all 2 & 4 whl dr mdls | \$7.95 |
| 1007 | BMW 1600 66-73 covers all models | \$9.95 |
| 1042 | BMW 2000, 2002 66-76 covers all mdls inc CA, CS, TI | \$9.95 |
| 9813 | BMW 320 75-79 covers all models | \$9.95 |
| 9760 | BMW 2500, 2800, 3.0 all mdls inc Bavaria & CS | \$10.95 |
| 0883 | BOBCAT, MERCURY 76-79 covers all models | \$7.95 |
| 0504 | BRONCO, FORD 66-77 all 2 & 4 whl drive models | \$7.95 |
| 0011 | BUICK 66-68 factory shop manual... must give year | \$17.95 |
| 0025 | BUICK 71-79 shop manual... must give year... No 72-73 | \$17.95 |
| 0727 | CADILLAC 68-74 all models except El Dorado | \$9.95 |
| 8678 | CAMARO 67-78 covers all 6 & V8 models | \$9.95 |
| 9557 | CAPRI 70-76 for all 2000, 2600, 2800 mdls | \$9.95 |
| 0379 | CHALLENGER 70-72 covers all 6 and V8 mdls | \$7.95 |
| 8331 | CHARGER 67-70 for all models inc 500 & R/T | \$7.95 |
| 8212 | CHARGER 71-75 covers all models | \$7.95 |
| 0383 | CHEVELLE 64-77 inc Malibu, Monte Carlo, El Camino | \$7.95 |
| 0838 | CHEVETTE 76-78 covers all models | \$9.95 |
| 1038 | CHEVROLET 29-40 covers all 6-cyl models | \$15.00 |
| 0888 | CHEVROLET 49-54 reprint of factory shop manual | \$16.00 |
| 0051 | CHEVROLET 55 or 57 reprint factory manual... give year | \$19.95 |
| 8407 | CHEVROLET 56 supplement to 55 manual | \$9.95 |
| 0870 | CHEVROLET 68-77 for all full size models | \$7.95 |
| 8187 | CHEVY II 62-68 covers all 4, 6 & V8 models | \$8.95 |
| 0779 | CHEVY LUV 72-77 covers all models | \$9.95 |
| 1661 | CHEVY PICK-UPS 67-78 all models & GMC | \$9.95 |
| 1662 | CHEVY VANS 67-78 for all models & GMC | \$9.95 |
| 1145 | CHRYSLER 55-71 all inc Newport, 300, New Yorker | \$9.95 |
| 0020 | CHRYSLER 72-79 factory manual... must give year | \$22.95 |
| 9588 | CITROEN ID, DS 67-75 covers all DS19, 20, 21 mdls | \$9.95 |
| 8539 | CITROEN SM reprint of factory service manual | \$19.95 |
| 8264 | COLT, DODGE 71-77 covers all models | \$9.95 |
| 9422 | COMET 60-65 covers all models | \$7.95 |
| 8211 | COMET 70-77 covers all models | \$7.95 |
| 8212 | CORONET, DODGE 71-75 covers all models | \$9.95 |
| 0477 | CORVAIR 60-69 covers all models | \$9.95 |
| 0478 | CORVETTE 57-65 covers all 283, 327 models | \$9.95 |
| 9481 | CORVETTE 66-76 covers all 327, 350, 427, 454 models | \$9.95 |
| 1756 | CRICKET, PLYMOUTH 70-73 also covers Hillman Avenger | \$9.95 |
| 9440 | DART & DEMON 65-67 covers all models | \$7.95 |
| 8188 | DART & DEMON 68-76 covers all models | \$7.95 |
| 1657 | DATSUN 1100 76-78 covers all models | \$9.95 |
| 1164 | DATSUN 200SX 77-79 covers all models | \$9.95 |
| 8065 | DATSUN 1200, B210 68-78 covers all models | \$9.95 |
| 8127 | DATSUN 240Z, 260Z, 280Z 70-78 covers all models | \$9.95 |
| 1551 | DATSUN 510 68-73 covers all sdn & wagon mdls | \$9.95 |
| 1074 | DATSUN 510 78-79 covers all models | \$9.95 |
| 9583 | DATSUN 610 68-77 covers all models | \$9.95 |
| 0935 | DATSUN 710 73-76 covers all models | \$9.95 |
| 8271 | DATSUN 810 77-78 for all models | \$9.95 |
| 1258 | DATSUN 311 1600/2000 SPL & SRL sports car mdls | \$10.95 |
| 9297 | DATSUN PICK-UP 68-77 covers all 521 & 620 models | \$9.95 |
| 1145 | DODGE 55-71 all inc Coronet, Monaco, Polara | \$9.95 |
| 0871 | DODGE 72-77 for all Monaco & Polara models | \$7.95 |
| 1259 | DODGE OMNI 78-79 covers all models | \$9.95 |
| 8208 | DODGE RAMCHARGER 74-75 covers all models | \$7.95 |
| 8564 | DODGE PICK-UP 65-75 service/maintain all 2-whl drive | \$7.50 |
| 8371 | DODGE PICK-UP 65-78 4-whl drive service/maintain all | \$7.50 |
| 8203 | DODGE VANS 67-77 all 100, 200, 300 mdls & Plymouth | \$7.95 |

| | | |
|------|---|---------|
| 8192 | DUSTER 70-76 for all models inc. Scamp | \$7.95 |
| 8189 | FAIRLANE, FORD 62-70 covers all models | \$7.95 |
| 9422 | FALCON 60-64 covers all models inc Mercury Comet | \$7.95 |
| 9874 | FALCON, FORD 6 64-70 covers all 6-cyl models | \$7.95 |
| 0480 | FALCON, FORD V8 65-71 covers all V8 models | \$7.95 |
| 9776 | FIAT 124 67-77 all inc sdn, sta wgn, TC, spcl | \$9.95 |
| 7118 | FIAT 124 SPORT 66-75 covers Coupe & spider mdls | \$9.95 |
| 0844 | FIAT 124 SPORT 76-78 for coupe & spider mdls | \$9.95 |
| 9640 | FIAT 128 72-79 for all models inc SL & Rally | \$9.95 |
| 8742 | FIAT 131 75-77 covers all Mirafiori models | \$9.95 |
| 1201 | FIAT 850 64-74 all sedan, coupe & spider mdls | \$9.95 |
| 0399 | FIAT X1/9 73-77 | \$9.95 |
| 1073 | FIESTA, FORD 77-79 for all models | \$9.95 |
| 0675 | FIREBIRD covers all models—67-74 | \$7.95 |
| 1149 | FORD 55-67 all inc Galaxie, LTD, Custom & wagons | \$9.95 |
| 0872 | FORD 68-77 Inc Galaxie, LTD, Custom, XL & wgn | \$7.95 |
| 9369 | FORD COURIER 72-77 covers all models imported | \$9.95 |
| 0451 | FORD PICK-UP 69-79 covers all models | \$9.95 |
| 8204 | FORD VANS 66-68 covers all models | \$7.95 |
| 0453 | FORD VANS 69-79 covers all 6 & V8 models | \$9.95 |
| 9436 | GRANADA, FORD 75-77 covers all models | \$7.95 |
| 8677 | GREMLIN & HORNET 71-77 covers all 6 & V8 models | \$9.95 |
| 0644 | HONDA 360, 600, 67-75 for all models inc "Z" | \$9.95 |
| 0885 | HONDA ACCORD 77-78 covers all CVCC models | \$9.95 |
| 8694 | HONDA CIVIC, 73-79 covers all models inc CVCC | \$9.95 |
| 8206 | INTERNATIONAL SCOUT 67-73 800, A, B, II mdls | \$7.95 |
| 8565 | INTERNATIONAL 62-78 tune/maintain Scout, wagon, pick-up | \$7.95 |
| 1207 | JAGUAR XK120, 140, 150 48-61 also Mk 7, 8, 9 | \$9.95 |
| 1206 | JAGUAR 55-69 sedan mdls 2.4, 3.4, 3.8, 240, 340 | \$9.95 |
| 1043 | JAGUAR E-TYPE 61-72 covers all 6-cylinder models | \$9.95 |
| 9612 | JAGUAR E-TYPE V12 71-74 covers all models | \$9.95 |
| 9399 | JAGUAR XJ6 68-78 covers all models | \$9.95 |
| 9617 | JAGUAR XJ12 72-77 for all models inc Daimler | \$9.95 |
| 9769 | JEEP 50-65 for 4 & 6 cyl station | \$15.95 |
| 8207 | JEEP 66-79 for all Cherokee, Commando & Wagoneer mdls | \$7.95 |
| 9805 | JEEP WAGONEER J-series with 230 ohc eng. | \$15.95 |
| 9806 | JEEP UNIVERSAL CJ-2, CJ-3 reprint factory manual | \$15.95 |
| 0509 | JEEP CJ-5, CJ-6, CJ-7, 55-79 | \$7.95 |
| 8856 | JEEP FC150, 170 covers all front cab models | \$15.95 |
| 8739 | JENSEN-HEALEY reprint of factory manual | \$19.95 |
| 1719 | LANDROVER 1, 2 48-61 for all models | \$9.95 |
| 1254 | LANDROVER 59-77 covers 2, 2A, 3 gas & diesel models | \$9.95 |
| 1149 | LINCOLN 55-70 covers all models | \$9.95 |
| 9773 | LINCOLN 71-77 all models inc Versailles | \$9.95 |
| 0481 | MAVERICK 69-71 6 cyl, 170, 200, 250 cu. in. eng. | \$7.95 |
| 8211 | MAVERICK 72-77 covers all models | \$7.95 |
| 1550 | MAZDA GLC 77-78 covers all models | \$9.95 |
| 0370 | MAZDA RX2 70-75 covers sedan & coupe mdls | \$9.95 |
| 0371 | MAZDA RX-3, 100 70-74 covers all models | \$9.95 |
| 0444 | MAZDA 71-78 includes RX4 and Cosmo models | \$7.95 |
| 0880 | MAZDA PICK-UP 72-75 B-1600 & rotary eng. mdls. | \$7.95 |
| 0593 | MAZDA 808, 818 72-78 covers all models | \$9.95 |
| 0573 | MAZDA 1500, 1800 67-74 covers all models | \$9.95 |
| 1009 | MERCEDES-BENZ 190 59-68, B, C & 200 models | \$9.95 |
| 0781 | MERCEDES-BENZ 190SL reprint of owner's manual | \$7.95 |
| 1746 | MERCEDES-BENZ 220 59-65 covers all mdls | \$9.95 |
| 9483 | MERCEDES-BENZ 220 68-72 mdls except Diesel | \$9.95 |
| 1747 | MERCEDES-BENZ 230 63-68 inc 230S & SL | \$9.95 |
| 1748 | MERCEDES-BENZ 250 65-68 covers all models | \$9.95 |
| 9484 | MERCEDES-BENZ 250 69-72 covers all models | \$9.95 |
| 9485 | MERCEDES-BENZ 280 68-72 covers all models | \$9.95 |
| 0416 | MERCEDES-BENZ 68-73 inc 280, 300 & 350, 450 V8 mdls | \$8.95 |
| 8439 | MERCEDES-BENZ 74-79 Covers all models inc Diesels | \$9.95 |
| 1149 | MERCURY 55-70 covers all models | \$9.95 |
| 9773 | MERCURY 71-77 for all models inc Cougar | \$9.95 |
| 1105 | MG TA, TB, TC, TD, TF 36-55 | \$9.95 |
| 1098 | MG MIDGET 58-78 covers all models | \$9.95 |
| 1106 | MGB, MGB 55-68 covers all models inc twin cam | \$9.95 |
| 1720 | MGB, MGBGT 69-79 all roadster & coupe models | \$9.95 |
| 8396 | MGC reprint of factory manual | \$19.95 |
| 0917 | MINI 59-78 covers all models inc Mini-Cooper | \$9.95 |
| 9436 | MONARCH, MERCURY 75-77 for all models | \$7.95 |

| | | |
|------|---|---------|
| 0050 | MONZA, CHEVROLET 77-79 factory manual... give car year | \$12.95 |
| 1109 | MORGAN 36-77 covers all 4-cyl models | \$9.95 |
| 8395 | MUSTANG 65-73 covers all 6-cylinder models | \$9.95 |
| 0479 | MUSTANG V8 65-73 covers all models | \$9.95 |
| 8272 | MUSTANG II 74-78 covers all 4, V6, & V8 models | \$9.95 |
| 8187 | NOVA 69-79 covers all 4, 6 & V8 models | \$8.95 |
| 7107 | OLDS CUTLASS 70-77 covers all inc 442 models | \$7.95 |
| 0002 | OLDS 68, 71, 74 factory shop manual... must give year | \$10.95 |
| 0008 | OLDS 75-79 factory shop manual... must give year | \$16.95 |
| 1724 | OPEL KADETT 62-73 1000, 1100, 1200 models | \$9.95 |
| 1752 | OPEL KADETT 67-73, 1500, 1700, 1900 mdls | \$9.95 |
| 0859 | OPEL 1900 MANTA 70-74 covers all coupe mdls | \$9.95 |
| 8273 | OPEL 75-78 covers all models inc Isuzu | \$9.95 |
| 9589 | OPEL GT 68-73 covers all 1900 models | \$9.95 |
| 9871 | PEUGEOT 304 70-77 covers all models | \$9.95 |
| 1541 | PEUGEOT 404 60-75 covers all models | \$9.95 |
| 0876 | PEUGEOT 504 68-74 includes diesel models | \$7.95 |
| 7124 | PEUGEOT 504 68-78 for all gasoline models | \$9.95 |
| 0883 | PINTO 70-79 covers all models inc Mercury Bobcat | \$7.95 |
| 1145 | PLYMOUTH 55-71 all inc Belvedere, Fury, Satellite | \$9.95 |
| 0874 | PLYMOUTH 72-76 Fury, VIP, Gran, Suburban mdls | \$7.95 |
| 1660 | PLYMOUTH HORIZON 78-79 covers all models | \$9.95 |
| 0030 | PONTIAC 69-75 factory manual, all models... give year | \$17.95 |
| 0489 | PONTIAC TEMPEST 68-73 all mdls inc GTO, Le Mans | \$7.95 |
| 1650 | PORSCHE 356 57-65 covers A, B & C models | \$9.95 |
| 1591 | PORSCHE 911 64-73 covers all models | \$9.95 |
| 8173 | PORSCHE 911 74-77 includes N, S, Targa, Carrera | \$9.95 |
| 1590 | PORSCHE 912 65-69 with 1582cc engine | \$9.95 |
| 9834 | PORSCHE 914 70-76 all models inc 914/6 | \$9.95 |
| 0993 | PORSCHE 924 76-78 | \$9.95 |
| 8208 | RAMCHARGER, TRAILDUSTER 74-75 all models | \$7.95 |
| 0372 | RENAULT 5 72-78 for all models inc Le Car | \$9.95 |
| 1224 | RENAULT 8, 10 62-72 covers all models inc 1100 | \$9.95 |
| 9429 | RENAULT 12 69-79 covers all models inc auto trans | \$9.95 |
| 0645 | RENAULT 15, 17 71-78 all mdls inc TL, TS | \$9.95 |
| 1554 | RENAULT 16 65-78 covers all models | \$9.95 |
| 0395 | ROADRUNNER & SATELLITE 68-73 all models | \$7.95 |
| 1121 | ROVER 2000 63-75 for all models inc 2200 | \$9.95 |
| 9493 | SAAB 95, 96 66-76 covers all V4 models | \$9.95 |
| 0750 | SAAB 99 69-76 covers all models inc fuel injection | \$9.95 |
| 8440 | SAAB 67-79 covers all models inc Sonnet | \$9.95 |
| 1098 | SPRITE 58-71 covers all Mk 1, 2, 3 & 4 models | \$9.95 |
| 8058 | SUBARU 70-79 covers all models | \$9.95 |
| 0853 | SUNBEAM ALPINE 55-65 Mk 1, 2, 3, 4 & Rapier | \$9.95 |
| 0845 | SUNBEAM TIGER reprint of factory shop manual | \$19.95 |
| 0489 | TEMPEST, GTO, LE MANS 68-73 all models | \$7.95 |
| 9773 | THUNDERBIRD 71-77 covers all models | \$9.95 |
| 8189 | TORINO 68-75 all models inc Elite, Ranchero | \$7.95 |
| 0912 | TOYOTA CELICA 70-77 covers all models imported | \$9.95 |
| 0829 | TOYOTA CELICA 78-79 | \$9.95 |
| 7127 | TOYOTA COROLLA 68-74 for all models | \$9.95 |
| 9812 | TOYOTA COROLLA 75-78 all models plus 5-spd trans | \$9.95 |
| 1738 | TOYOTA CORONA 65-68 covers 4-cyl 1500 models | \$9.95 |
| 0926 | TOYOTA CORONA 69-73 for all 4-cyl models inc MK II | \$9.95 |
| 0886 | TOYOTA CORONA 74-77 covers all 4-cyl models | \$9.95 |
| 0754 | TOYOTA CORONA Mk 2 72-76 for all 6 cylinder models | \$9.95 |
| 0647 | TOYOTA HI-LUX 68-77 covers all pick-up models | \$9.95 |
| 8524 | TOYOTA LAND CRUISER 66-77 covers i77 models | \$9.95 |
| 0687 | TRIUMPH STAG 70-77 | \$9.95 |
| 1200 | TRIUMPH SPITFIRE 69-78 covers all models | \$9.95 |
| 1016 | TRIUMPH GT6 62-74 for all models plus Vitesse | \$9.95 |
| 1225 | TRIUMPH TR2, TR3, 52-62 covers all models | \$9.95 |
| 1231 | TRIUMPH TR4 61-67 covers all models | \$9.95 |
| 1015 | TRIUMPH TR5, TR6, 67-76 all models inc TR250 | \$9.95 |
| 8693 | TRIUMPH TR7 75-79 | \$9.95 |
| 8192 | VALIANT 68-76 all mdls inc Scamp, Signette | \$7.95 |
| 0567 | VEGA 72-73 all 140 CID & GT 140 CID models | \$7.95 |
| 0884 | VEGA 74-77 covers all models | \$7.95 |
| 9404 | VOLARE, PLYMOUTH 76-78 for all models | \$7.95 |
| 1227 | VOLKSWAGEN BEETLE 54-67 for all mdls inc K-G | \$9.95 |
| 0140 | VOLKSWAGEN BEETLE 68-77 covers all models inc K-G | \$9.95 |
| 6010 | VOLKSWAGEN RABBIT, SCIROCCO 74-79 all mdls inc Diesel | \$16.95 |
| 1547 | VOLKSWAGEN BUS 54-67 all camper, van, transporter mdls | \$9.95 |
| 7130 | VOLKSWAGEN BUS 68-78 all camper, van, transporter mdls | \$9.95 |
| 9582 | VOLKSWAGEN TYPE 3 62-73 for squareback, fastback | \$9.95 |
| 9639 | VOLKSWAGEN 411 68-73 covers all E, L, LE models | \$9.95 |
| 9778 | VOLKSWAGEN 412 71-74 covers all models | \$9.95 |
| 8748 | VOLKSWAGEN Dasher 74-78 covers all models | \$14.95 |
| 9444 | VOLVO P1800 60-73 all models inc E & ES | \$9.95 |
| 1722 | VOLVO 122 61-70 for all models inc GT | \$9.95 |
| 1754 | VOLVO 142, 144, 145 66-74 for all models inc S & E | \$9.95 |
| 9558 | VOLVO 164 68-75 for all models inc fuel injection | \$9.95 |
| 3729 | VOLVO 242, 244, 245 74-78 for all inc fuel inj models | \$9.95 |
| 8311 | VOLVO 262, 264, 265 75-78 all models inc fuel injection | \$9.95 |

GENERAL INTEREST BOOKS

| | | |
|------|---|---------|
| 1264 | CHILTON AUTO REPAIR 73-80 for all American cars | \$16.95 |
| 0743 | CHILTON AUTO REPAIR 72-79 for all American cars | \$14.95 |
| 1775 | CHILTON AUTO REPAIR 68-75 Reg. \$12.95, Special | \$6.95 |
| 1763 | CHILTON AUTO REPAIR 54-63 | |

Be an Electrician



**CONSTRUCTION
MAINTENANCE
CONTRACTOR**

Train at home
in spare time

MAKE MORE MONEY! Check out Electrician's wages against the kind of money you make now!

Even before you're ready to go after a full-time job as an electrician, you could be making extra money doing odd jobs for friends and neighbors. And think of the money you'll be able to save doing your own electrical work. Learn to specify and install wiring, operate and control motors and generators, use and maintain transformers and storage batteries. We show you how to troubleshoot for short circuits, overloads and open wires. You'll be ready to pass almost any electrician licensing examination offered by state, city or county.



**APPROVED
G.I.S
VETERANS**

NO NEED TO QUIT YOUR JOB OR REGULAR SCHOOL. Everything explained in easy-to-understand language with plenty of drawings, diagrams and photos. Tools, materials, test equipment included with course. You learn at your own pace. No time wasted traveling to class. Teachers are as close as your telephone. No charge! Use our toll-free 24-hour home-study hotline as soon as you enroll.

MAIL COUPON TODAY! No cost, no obligation, no salesman will call!

ICS
SINCE 1890

ELECTRICIAN SCHOOL, Dept. PC020
ICS Center, Scranton, PA 18515

Rush free facts that tell how I can train at home in spare time to be an electrician.

NAME.....AGE.....
ADDRESS.....
CITY/STATE/ZIP.....

**Lock Blade
TIGER KNIFE**
7 1/2" Overall Length



Rugged Stainless Steel Blade that locks into open position. Safety folding finger guard. Razor sharp hand-hollow ground blade.

\$3.95 Each

A Superb Folding Hunting Knife

WESTBURY SALES CO.

P.O. Box 434 Westbury, New York 11590 Dept. L-3-PS

SAVE UP TO 85%

GOV'T SURPLUS and NEW EQUIP'T



**ENERGY BOOSTER
CENTRIFUGAL BLOWER**

200 CFM, 115-VAC
\$13.95 Normal Retail Over \$40.00

BIG, Equipt. Catalog



Send 50¢ Coin or Stamps

* (ITEM #14-922) - Boost efficiency of woodburning stoves or heaters, circulate heat in solar systems, use for dozens of air conditioning, air intake, ventilating applications. Useful for forced draft, cooling, drying, etc.
* 200 CFM, 115-VAC, 2.2-amp, motor, thermally protected. Dynamically balanced 6" diam. rotor. Intake 3" diam., rectangular discharge 3" x 3-1/4". Overall 8-1/4" x 8-1/4" x 7-1/4". Shpg. wt. 8 lbs.

SURPLUS CENTER

PS-030

Lincoln, Nebraska
Zip Code 68501

LOUD AND CLEAR.
Read all about the K—the amazing speaker that has the power to reproduce even the lowest bass notes—loud and clear. Features the brilliant cornhorn design with Speakerlab innovations like Magnar™ damped horn drivers. One of the only kits available for this unique loudspeaker. Read about K's and all the other great Speakerlab speakers and parts in our free catalog.

Speakerlab
To get yours, write
SPEAKERLAB, Dept. 188
735 N. Northlake Way
Seattle, WA 98103

Your home workshop can pay off BIG... with this

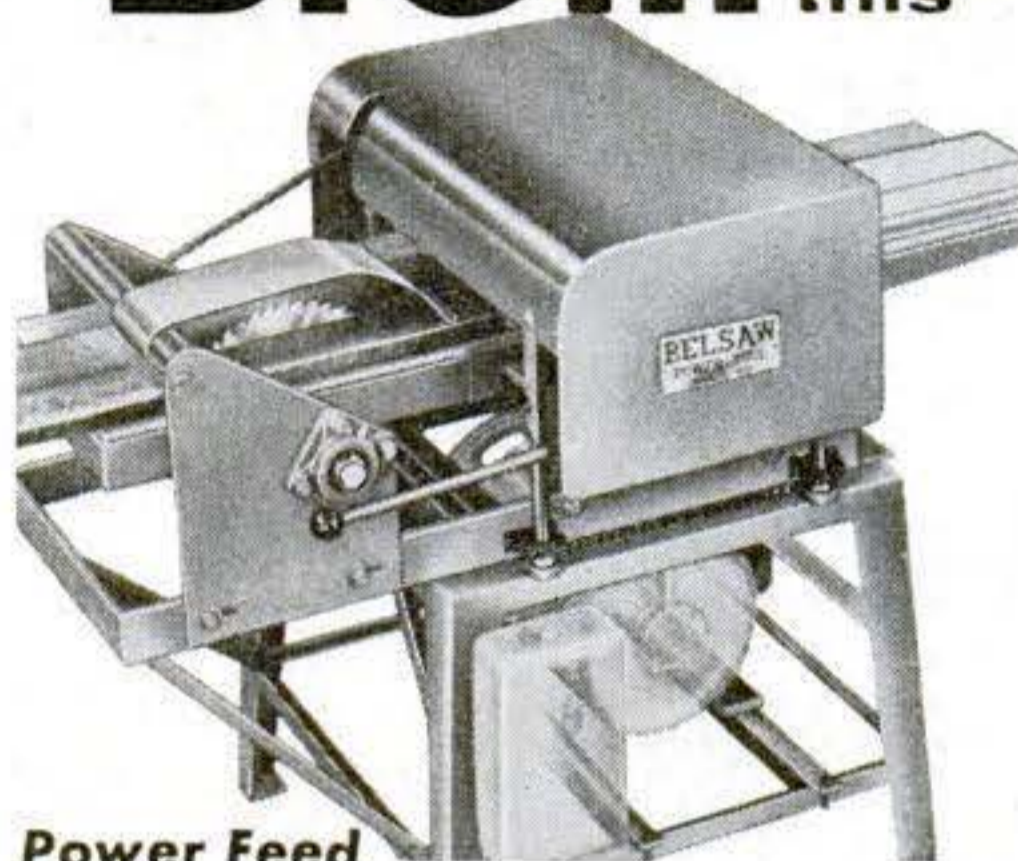

Power Feed

Planer Molder Saw

Three power tools in one—
a real money-maker for you!

The BELSAW Planer/Molder/Saw is a versatile piece of machinery. It turns out profitable precision molding, trim, flooring, furniture...in all popular patterns. Rips, planes, molds separately...or all at once. Used by individual home craftsman, cabinet and picture framing shops, lumber yards, contractors and carpenters.

Never before has there been a three-way, heavy-duty woodworker that does so many jobs for so little cost. Saws to width, planes to desired thickness, and molds to any choice of patterns. Cuts any molding pattern you desire. Provides trouble-free performance. And is so simple to operate even beginners can use it!

30-Day FREE Trial! SEND FOR EXCITING FACTS
NO OBLIGATION—NO SALESMAN WILL CALL
RUSH COUPON TODAY! BELSAW POWER TOOLS CO.
920M Field Bldg.
Kansas City, Mo. 64111

NAME.....
ADDRESS.....
CITY.....
STATE.....ZIP.....

BELSAW POWER TOOLS

920M Field Bldg., Kansas City, Mo. 64111

Please send me complete facts about PLANER—MOLDER—SAW and details about 30-day trial offer. No obligation, no salesman will call.

Back-country gear

[Continued from page 79]

with Polarguard, one side thicker than the other. Put the blue side on top in colder weather; put the rust side up when it's warm. This roomy, rectangular bag is designed for family camping. It comes in two sizes: six feet or six feet, eight inches long.

Stephenson's Warmlite Triple bag, like his tent, is designed to handle the most extreme conditions. It's comfortable over a very broad temperature range (60 degrees F to -50 degrees F, says the company) because it has two tops, one twice as thick as the other. A sophisticated zipper system lets you use them both together or zip out either one, using only the second. These multi-zippers also let you zip two or more bags together on either side, unzip the sides for ventilation, or unzip the bottom.

The Warmlite bag has another unusual feature: A two-inch-thick, polyether urethane open-cell foam pad or a down-filled air mattress is built in. Thus your bag won't slip off your sleeping surface during the night. And you don't pack—or pay for—down that will only be squashed useless beneath you anyway.

Other features of the Warmlite bag: The inner fabric has a vapor-barrier coating to reduce evaporative heat loss and to protect the down from body moisture, which would destroy its loft and warmth. The fabric coating is also aluminized to reduce radiant heat loss. For more warmth, you can close a goose-down collar around your shoulders. And the hood is fitted, much like a parka hood.

The Warmlite Triple is a big bag—with foam pad it weighs 5 1/4 pounds and packs into a 12-by-23-inch stuff sack. It's less bulky with the down mattress: 4 3/4 pounds and 10 by 20 inches when packed. But with either one, you don't need a separate sleeping surface, so your total weight and bulk are not increased. And in mild weather, you can leave one top at home.

These and the other items in our collection of camping and trail gear are shown in the photos. Perhaps you'll find just what you need to enhance your pleasure, convenience, and safety when you head for the back country.

MANUFACTURERS AND SUPPLIERS

L.L. Bean, Freeport ME 04033; Broil Pak, Portable Cookery, Inc., Box 2158, Madison WI 53701; Camp Trails Co., 4111 W. Clarendon Ave., Phoenix AZ 85019; The Coleman Co., Inc., 250 N. St. Francis, Wichita KS 67201; Early Winters, Ltd., 110 Prefontaine Pl. S., Seattle WA 98104; Eureka Tent, Inc., 625 Conklin Rd., Box 966, Binghamton NY 13903; Moss Tent Works, Mt. Battie St., Camden ME 04843; Quest Vest, Box 99, Bozeman MT 59715; Stephenson's Warmlite, RFD 4, Box 398, Gilford NH 03246 (catalog \$1); Tamrac, Box 4690, N. Hollywood CA 91607; Tough Traveler, 1328 State St., Schenectady NY.

Build Your Own DOME HOME



Cut 6-inch thick polystyrene panels, join them to form a dome, apply steel mesh and 2-inch cement. This patent pending new technology allows you to build a beautiful, spacious, super energy saving dome home at a fraction of the cost of conventional construction. Let us tell you how in our book entitled, "BUILD YOUR OWN GEODESIC DOME." Send \$5.00 to:
KEY DOME ENGINEERING Dept PS-4 P.O. Box 438253, SOUTH MIAMI, FLORIDA 33143
For brochure, list of materials and cost estimate of 32- and 40-foot diameter domes send just \$1.00

Clock Components



Clock Movements: Battery, Quartz, Electric, Urgos Grandmother, Grandfather, Westminster & Triple Chime, 8 Day Key Winds & Westminster, Bim Bams, Barometers, Metal, Bezel, Paper dials, Hands, Brass & Plastic Numbers & Markers. Hundreds of Items. Quantity Prices. Send \$1.00 for 60 Page Catalog. Refunded on \$10.00 Order.

NEWPORT ENTERPRISES, INC. DEPT C
2313 W. Burbank Blvd., Burbank, Calif. 91506

Remarkable portable pump

Blow Up Anything Fast & Easy!

Gives 100 lbs. of air Pressure INSTANTLY!

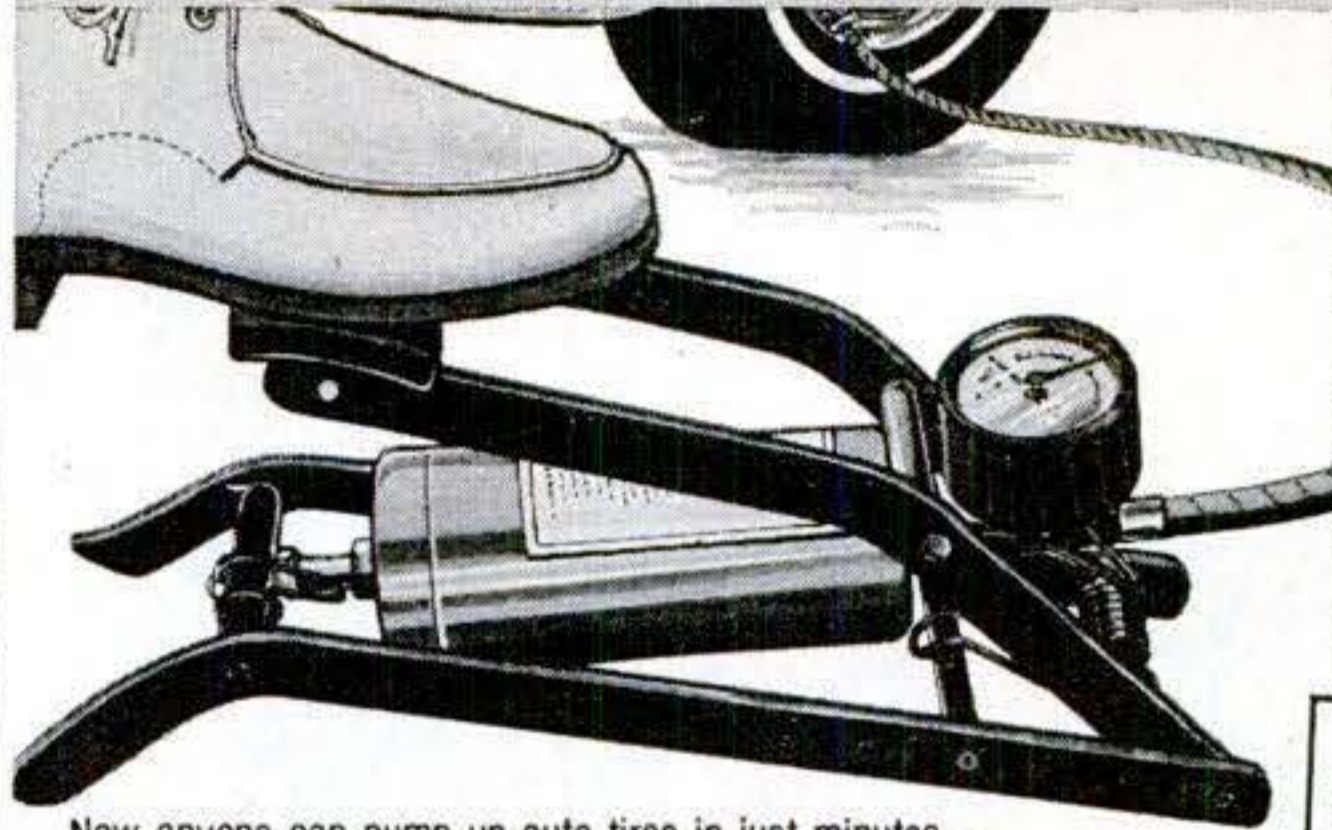

No Guessing! Built-In Pressure Gauge Gives Exact Inflation At A Glance!

**FOR TOYS,
SPORTING GOODS,
CARS & BIKE TIRES!**

Now anyone can pump up auto tires in just minutes — toys, balls, sports equipment, air mattresses, rafts and bike tires pump up in seconds!

This rugged, compact air pump is light weight, completely portable, works with a tip-toe action that's so easy to do. Yet this amazingly powerful pump gives up to 100 pounds of pressure instantly!

Comes complete with a flexible, 24" high-pressure hose and air-tight quick-lock clamp that connects to any tire or air shock made. Also comes with free funnel valve for inflatable toys.

Nowadays, with air so hard to find in service stations, you'll want to order two — one for home, one to keep in the trunk of your car for emergencies! Just \$14.99 each, or order two for \$28.99 and save.

90-DAY MONEY-BACK GUARANTEE. You must be delighted with the ease and convenience of our powerful Portable Air Pump, or return within 90 days for refund of purchase price (except shipping & handling).

PHONE YOUR ORDER TOLL-FREE:
If you have Master Charge or VISA phone
1-800-327-2777 ext. 2. (In Fla. 1-800-432-2766 ext. 2) 24 hrs. 7 days per wk. (min. charge \$10.)

mass marketing Assn. Inc.

10850 Riverside Dr., Dept. 512-2 N. Hollywood, Ca. 91602

Mass Marketing Assn., Inc., Dept. 512-2
10850 Riverside Dr., N. Hollywood, Ca. 91602

Please RUSH me _____ Portable Air Pump(s) #72613 at purchase price of \$14.99 plus \$2.00 shipping and handling each.

SAVE! Send TWO for just \$28.99 plus \$3.00 shipping and handling.

Enclosed is my check or money order for \$ _____
Sorry, no C.O.D.'s (Ca. res. please add sales tax.)

I prefer to charge my VISA, Master Charge

Card Number _____

MC Interbank # _____ Card Expires _____

Print Name _____

Address _____

City _____

State _____ Zip _____

Gazebo Study Plan Book



Custom Design your own Gazebo!

The unique Gazebo Study Plan Book enables you to Custom Design your own Gazebo or select one from 23 beautiful designs featuring 5 Classic Styles. And it's only \$4.50, plus 75¢ postage and handling; allow 3-4 weeks for delivery, or \$1.30 for First Class. Complete plans are also available.

SUN DESIGNS

P.O. Box 157 Dept. 20
Delafield, WI 53018

onComputing™

GUIDE TO PERSONAL COMPUTING

A new quarterly from the editors of BYTE.

Become an **onComputing** reader. You will find how to get started, what you will need, where to buy a computer and how to use it.

onComputing readers learn about the capabilities of microcomputers in non-technical language. They find out how a computer can be

a useful and creative tool for business, education, laboratory work, home entertainment and other applications.

onComputing is on sale at computer stores or available through subscription.

EVERY THREE MONTHS **onComputing** will bring the latest developments in the field of personal computing: use, applications, books, selection — all in an easy-to-read style.

onComputing Subscription Department, P.O. Box 307, Martinsville, NJ 08836

REGULAR subscription rate.

U.S. 1 yr. (4 issues) @ \$8.50 Canada & Mexico 1 yr. (4 issues) @ \$10.00

FOREIGN (to expedite service, please remit in U.S. funds drawn on a U.S. bank.)

Europe (and all other countries, except above) 1 yr. @ \$12.00 — surface delivery

Bill VISA Bill Master Charge Bill me (North America only)

Card Number _____ Expiration _____

Signature _____

Name (Please print) _____

Street/Apartment Number _____

City _____

State/Province/County _____

Postal Code _____

HOW TO

Caulk a tub the sure way. First, fill the tub with water and get in it, if you can. Then apply caulk. When tub is empty, it'll rise slightly and squeeze the caulk. Even a good flexible caulk (like Red Devil's) will serve you longer when the filled weight is not stretching it between the tub and wall.

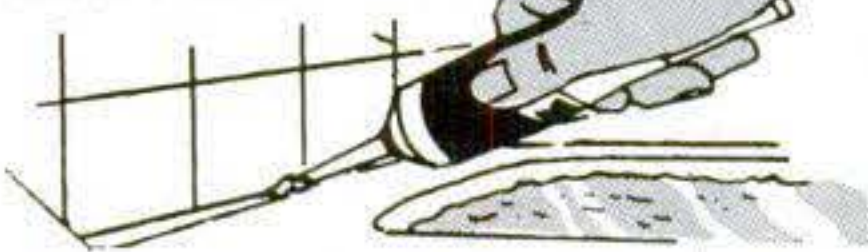

Give your new bathroom or mosaics a decorator look. Add a touch of color to the grout before you put it between the tiles. Just mix acrylic paint tint (from wherever you buy paint) with Red Devil Instant Tile Grout and see the exciting effect it creates.



Distinguish between a putty knife and a scraper. Putty knives (for spackling walls and puttying windows) have flexible blades to smooth on the material. Scraper blades are stiff, to keep the edge against the coating being removed. To do these jobs right, you need both tools (both from Red Devil, of course).

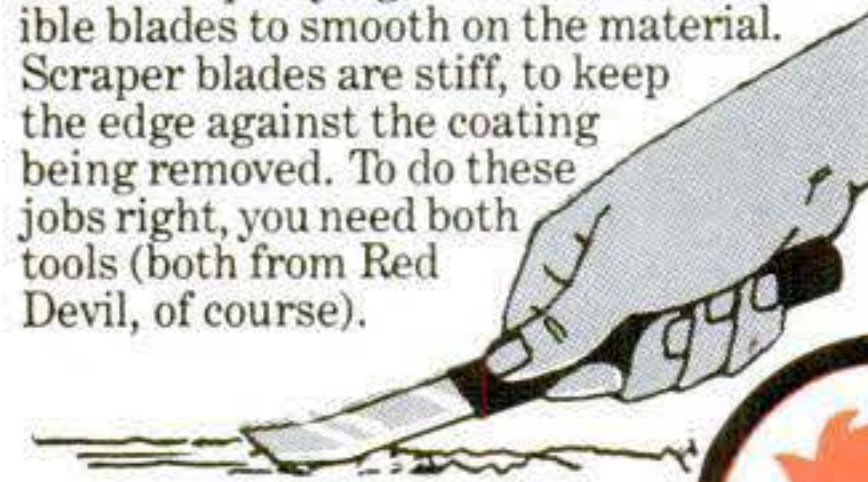

Use a glass cutter properly.

You don't cut the glass—you score it to release surface tension. So don't press too hard or go over it a second time. Hold your Red Devil cutter between the index and middle fingers as shown (a drop of oil on the cutter helps, too). Then, you've got the score.



Save energy with Red Devil's caulks, patches and fillers.

Fill spaces around windows, doors, vents and where the foundation meets siding with Red Devil's complete line of energy-saving cartridge products. Red Devil Lifetime™ Caulk has the longest life—it's warranted to last as long as you own your home or Red Devil will replace it free of charge!

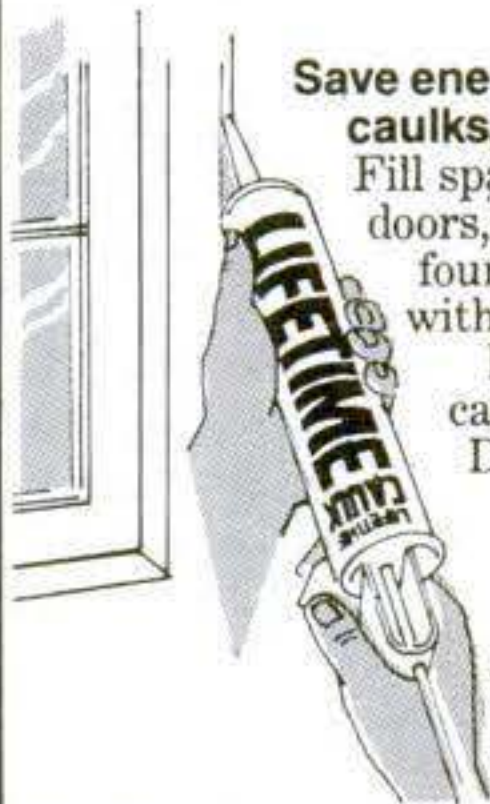

Red Devil has hundreds of things to make your home fix-up easier. Look for them wherever you shop for home-care products. And for best results, always follow directions on the package.



Red Devil

Red Devil, Inc., Union, N.J. 07083

Woodstove cottage

[Continued from page 111]

In the summer, this flow pattern can be as effective for cooling. Just open the projecting casements over the window seats, plus the upstairs windows on the east wall, and you'll send breezes from west and south up through the louvers. In most vacation areas, this feature should make air conditioning unnecessary.

And in many climate zones, your wood stove could heat the entire house. For example: With design temperatures of -15 degrees F outside and 68 degrees F inside, a No. 4 or No. 6 Combi-Fire stove by Jøtul could supply the 45,000 Btu required. An even more efficient heating system might combine such a stove with electric-resistance baseboard that would provide supplemental heat at extreme temperatures and when the house is vacant.

If you're not into wood as a major heat source, replace the stove with a stove-fireplace; this will contribute Btu to supplement a central furnace—space for which is provided in the mudroom.

Use of glass in this house has been considered for its effect on heat loss. The northern exposure has limited glazing, while the walls to the east and south are more open, with sliding glass doors giving onto the decks.

That welcoming deck across the front leads to an entry that is recessed from winter drafts. The big living room with its sloping ceiling is the social center of the house. Two window seats supplement the central furniture grouping.

The adjacent kitchen has generous eat-in space, and beyond it is the mudroom with an auxiliary entrance, a shower, and laundry equipment.

There's a full bath downstairs, and a bedroom with its own sliding glass door to a private deck. Directly above this area is an identically sized room with its own balcony. You take your choice as to which becomes the master bedroom—weighing accessibility against privacy. Also, in the winter you may want to close off that back corner and move up to the snug rooms tucked under the ridge. 5

How to order your plans

One set of detailed, professionally drawn blueprints for this cottage is \$65; five sets (for construction, financing, obtaining permits), \$95; materials list and specifications included at no extra cost. A mirror-reverse print can be ordered for \$10. Address orders or queries to Homes for Living, Inc. (specify Timbers Plan), 107-40 Queens Blvd., Forest Hills, N.Y. 11375. Add \$3 for postage and handling.

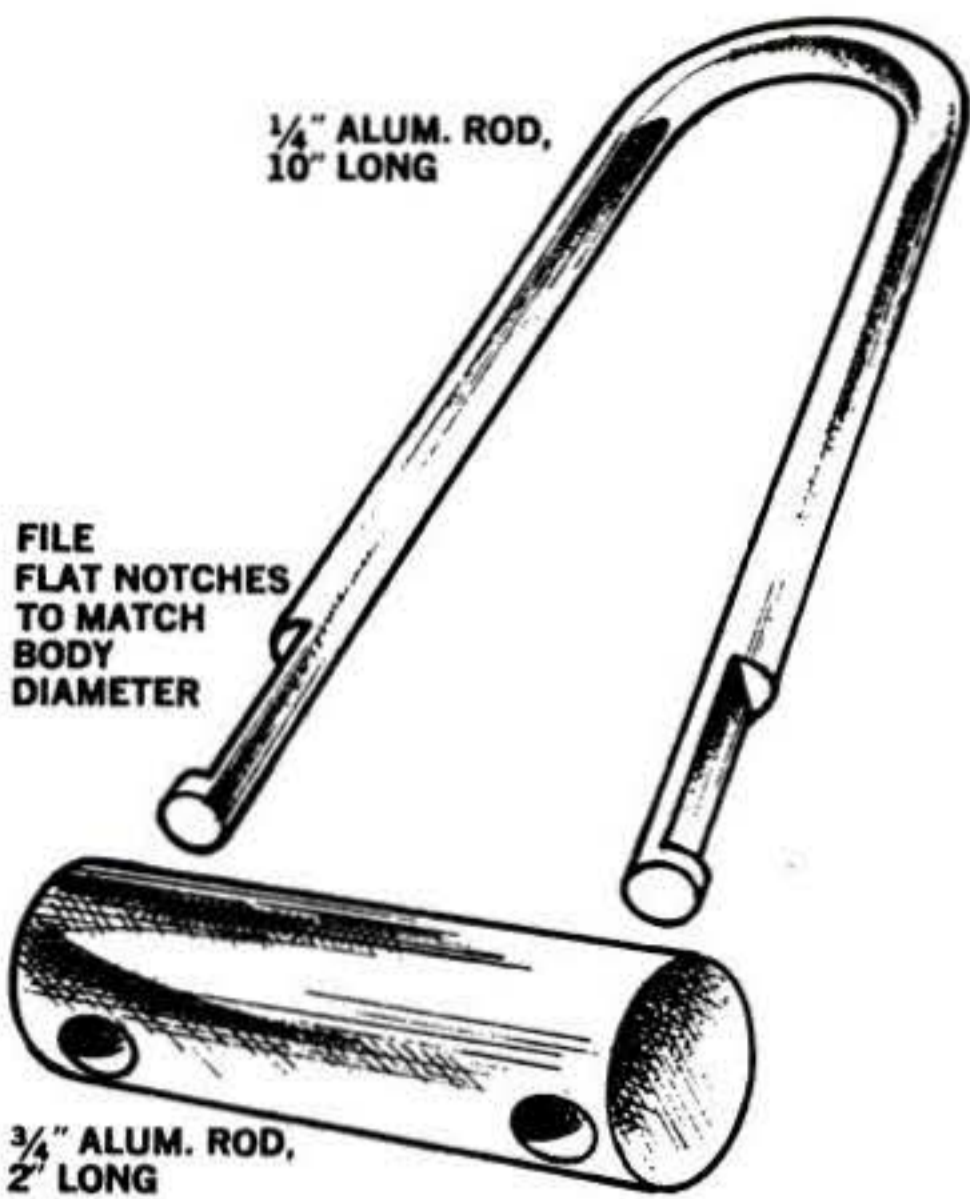

Keyless lock

It won't secure valuables or foil burglars, but it will keep young children within gates and away from unsafe areas. It's made from 1/4- and 3/4-in. aluminum rod—bent, filed, and drilled as shown. To lock, you compress the shackle and slide it into the body holes until the notches engage. Compress and pull to unlock. Want to increase the compression required? Spread sides farther apart.—*Roy DeRenzo*

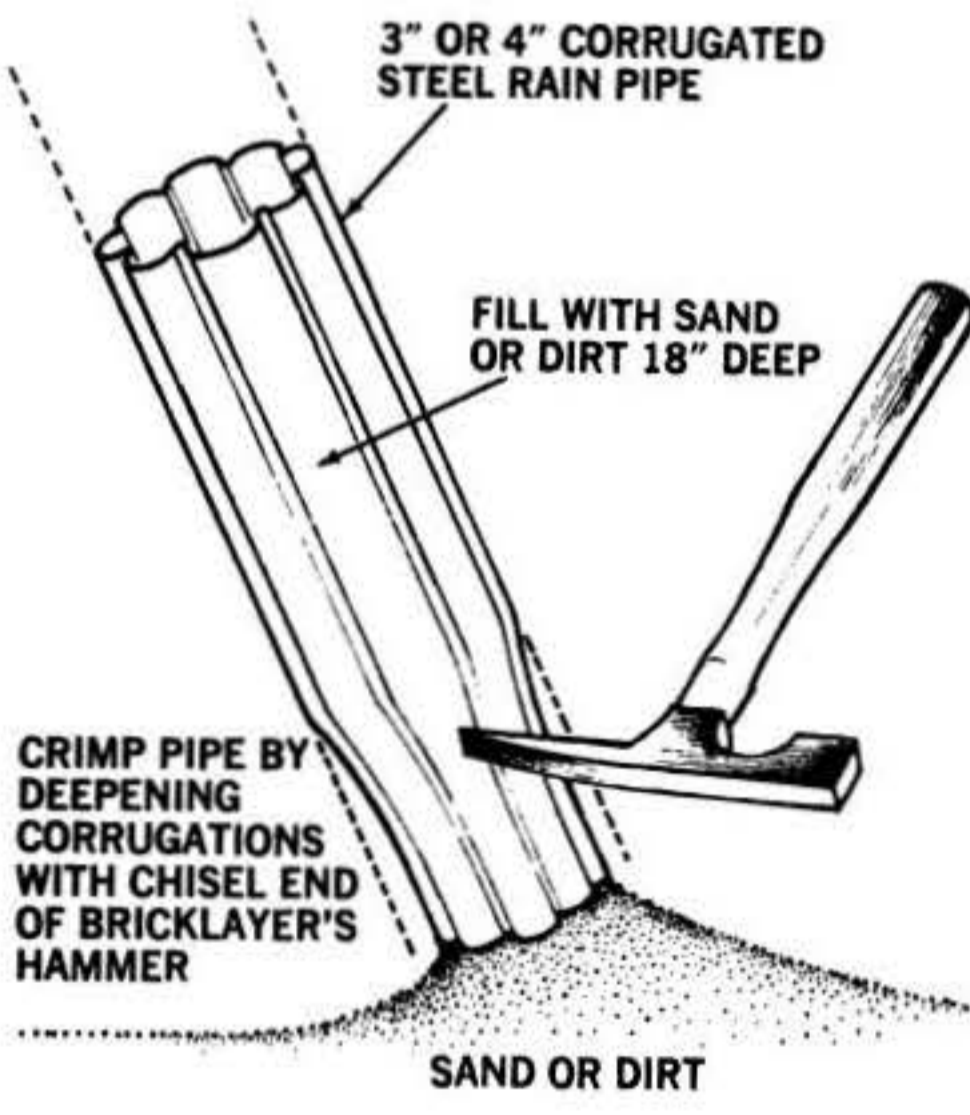

Crimping downspout

Replacing a section of rusted-out rain pipe can be a frustrating chore if you can't slip the new section far enough toward the spigot end for it to clear at the bell end. The sketch shows a technique to lengthen the crimps in steel rain pipe. Put about 18 inches of sand into the male end for ballast, and stand it on end. Then lightly strike the corrugations with the chisel end of a bricklayer's hammer or similar tool to deepen the grooves. This gradually pinches the end and takes a half inch off the circumference.—*Andy Vena*



Steuben?

No! Your glass, etched by you with **Armour Etch™**, an exciting new do-it-yourself kit that revives the ancient art of etching. With it, you can create rich, permanently etched designs — as beautiful as collector's items — on any glassware, windows or mirrors. You won't believe how easy it is!

No art talent necessary
Just trace, cut, apply Armour Etch. Use our patterns or any that strike your fancy from magazines, newspapers, craft books, etc.

Now you can etch:
All Glass Windows, Mirrors, Household Glassware, Stained Glass, Lamps, Fish Tanks, Terrariums, Storm Doors, Auto Glass, Fireplace Doors, China Cabinets.



Kit contains:
Armour Etch Cream, applicator brush, Armour Cleaner Concentrate, hobby knife, masking vinyl, reusable vinyl gloves, step-by-step illustrated instruction book. **PLUS 45 full size etching patterns.**
only \$9.95

ARMOUR PRODUCTS Dept. PS-30
Hill St., Midland Park, N.J. 07432, U.S.A.
Please send me _____ Armour Etch kits at \$9.95. Add \$1.50 for postage and handling. (New Jersey residents add 5% sales tax.)

Name _____
Address _____
City _____
State _____ Zip _____

Let Belsaw prove YOU can
Earn Up To
\$800 an Hour

In YOUR OWN SPARE TIME or FULLTIME



SHARPENING BUSINESS!

On our 30-DAY FREE TRIAL OFFER
You risk nothing by accepting this offer to see how easily you can turn your spare time into big Cash Profits with your own Complete Sharpening Shop. No selling... no previous experience needed. Our famous Sharp-All and show-how instruction set you up to make \$200, \$500, \$700 a month CASH sharpening Saws, Knives, Scissors, Lawnmowers, Shop and Garden Tools... all cutting edges.

LIFETIME SECURITY with YOUR OWN BUSINESS
FREE BOOK! Gives Full Details

Send for all the facts! Our Free Book tells how to start a profitable, lifetime home sharpening business, how we help you grow, how we'll finance you.

Send for FREE details—mail coupon below or postcard TODAY!
BELSAW SHARP-ALL CO., 700M Field Bldg. Kansas City, Mo. 64111
No Obligation... No Salesman Will Call
 YES, **BELSAW, 700M Field Bldg., Kansas City, Mo. 64111**
please send me the **FREE BOOK** that gives full details.

Name _____ Please Print _____
Address _____
City-State _____ Zip _____

RICKA DUO-WHEEL CONVERSION KIT AND FIBERGLASS FENDERS

New wide tire adapters & fenders to fit most mini - 1/2, 3/4 & 1 ton trucks. Simple bolt on installation. Increases traction, tire capacity & life.

The ultimate in safety protection for your family.

RICKA MFG. DEPT. RPS-3
Pequot Lakes, MN 56472

RE-LITE
2 bulb fixture duplicates the charm and increases the light output of a double mantle gaslight. Kit includes on-at-dusk, off-at-dawn photo control, fixture, bulbs, detailed instructions. Your energy savings will pay for this kit in less than 6 months. 115 volt kit \$29.95 postpaid, or safe 12 volt kit including plug-in transformer, \$39.95. Dealers and installers inquiries invited.

Yardlighting Systems, Inc.
1678 Hewitt Dept. 55 • St. Paul, MN 55104

10 YEAR Guarantee
\$4.50

A GREAT all purpose knife for the outdoorsman. Offers you the quality of **CUSTOM** made models selling for much more! Hand polished imported surgical steel blade has **SAFETY LOCK** to prevent accidental closing. Expensive **Pacca** wood handle. **SOLID BRASS** bolsters and liner. Popular 4" size (7 1/2" open). **IF BROKEN IN 10 YEARS WE WILL REPLACE AT NO CHARGE!** Use 30 days, money back if not pleased. Send \$4.50 plus 48¢ postage & handling TODAY. Midwest Knife Co., Dept. W-3016, 9043 S. Western Ave., Chicago, Ill. 60620. Mail orders only.

NEW! DRILLS WATER WELLS

50...100...200 FEET DEEP
Saves You Hundreds of Dollars!

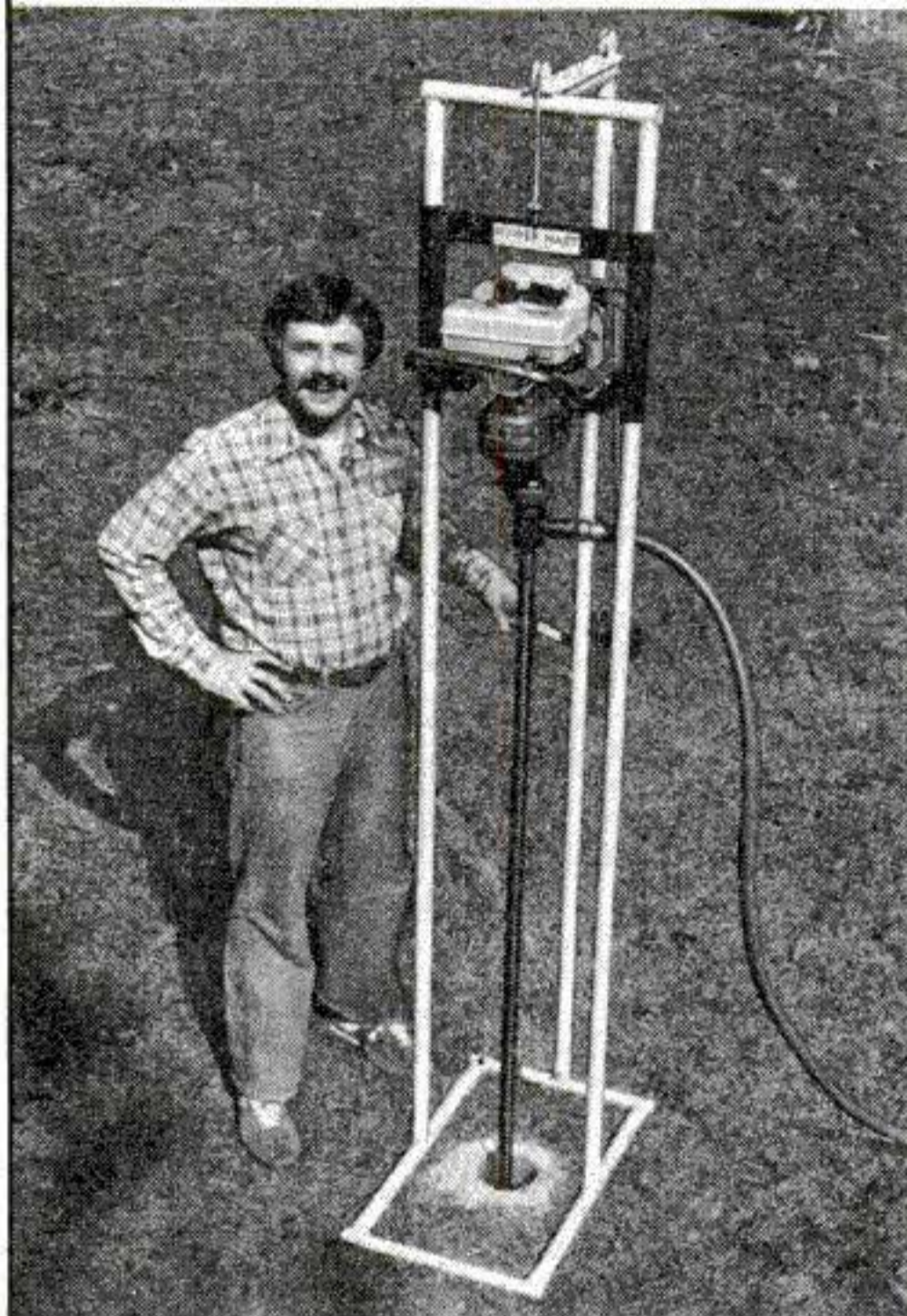

Did you know that vast quantities of fresh, sparkling clear water lie within 200 feet of the surface of the ground almost everywhere? In the city. In the suburbs. In the country. Pure, tasty water untouched by chemicals or pollutants.

Thousands of home owners are now drilling their own wells from 50 to 200 feet deep! YOU can join them in saying goodbye forever to expensive, chemical-tasting city water! Forget about droughts! Ignore summertime water shortages!

You owe it to yourself to find out more about this practical economical way to provide good, year 'round water for your home and garden.

Write or call today for a big, illustrated brochure and 24-page booklet on how to drill your own well. The big fact filled package will be rushed to you by First Class Mail!

Deeprook Mfg. Co.
Opelika, Alabama 36801

FREE Phone Toll-Free

(800) 821-2280

(Ask for Extension 5036)

Call anytime including Sundays.

OR CLIP COUPON AND MAIL TODAY!

Deeprook Mfg. Co., Dept. PS30
Opelika, Alabama 36801

Please mail your free information kit. I understand there is no obligation.

PRINT NAME _____

ADDRESS _____

CITY _____

STATE _____

ZIP _____

© 1980 Deeprook Mfg. Co.

Gas-saving devices

[Continued from page 119]

in a reservoir mounted under the hood. Outside air is drawn into the reservoir by engine vacuum and directed to a point below the level of the mixture. The resulting bubbling action creates a moisture-laden air mixture at the top of the reservoir that is drawn off to be injected into the carburetor. The composition of Econo Mix by volume is 65 percent methanol, 34 percent acetone, and one percent propylene glycol.

Benefits claimed for the Mark II are a decrease in required octane, increased fuel economy, increased power, elimination of carbon deposits, extension of engine life, and reduction of emissions. It was also claimed that the benefits would occur after the system had been "broken in," so the EPA tested the device after 2000 miles of operation on the engine.

EPA tests showed that there was no difference in fuel economy. Nor was any improvement in performance noted, according to the agency.

Tests on other vapor-injector systems showed these results: With Turbo Vapor Injector, "no reduction in fuel consumption was observed"; SCATPAC resulted in "no statistically significant change in fuel economy"; Frantz Vapor Injector and Econo-Mist "did not yield any improvements." The claims of water-injection-device marketers center on the fact that addition of water to the combustion chamber reduces knock, and thereby improves the burning process in the engine. At the same time, it may allow the engine to run at a slightly advanced spark setting. (The farther the spark is advanced, within limits, the better the fuel economy.)

"But in the real world, I don't think you're going to find it," says the EPA's Hutchins. "When water injection was used in aircraft during WW II, you were dealing with supercharged engines, trying to get extra power during takeoff under battle conditions."

Hutchins sees little similarity in modern car driving. To duplicate the airplane experience you would have to drive constantly under extreme conditions, with full throttle.

"You don't run an automobile engine like that," Hutchins concludes. "You run it at five to 10 percent of its rated power most of its life."

Air filters

In one test of an air-filter device, the EPA team found that a urethane-foam filter element made by Filtron Products Co., Van Nuys, Calif., "did not cause either a significant reduction in exhaust emissions or a marked

improvement in fuel economy." The urethane element is designed to replace the paper filter used in most engine air-induction systems. Its apparent cost is about twice that of the paper element.

It's impossible to pinpoint just how many consumer dollars are wasted on mileage boosters each year. But the Federal Trade Commission does have one example, that of the "GR Valve," whose sellers it successfully prosecuted last year. In one 90-day period, a mail-order firm sold 36,000 of these devices at \$16 apiece. The take was \$576,000. Its costs? "The cost of making the device is miniscule," reports William Haynes, a lawyer with the FTC's Bureau of Consumer Protection. "They operate on a shoestring by putting inexpensive ads in papers or on television."

Why are fuel-saving devices promoted in publications and on television despite the fact that EPA tests show they don't perform as claimed?

The FTC's Bureau of Consumer Protection is taking an aggressive attitude toward fuel-saving devices, but it's unable to stop manufacturer's from advertising. Currently the FTC has a number of investigations under way that should result in convictions. But that probably will not stop the stream of gimmicks.

"There are over 100 different devices, systems, or additives being sold under different names," says Haynes. "Because we have no censorship laws, the advertisements for these products will continue. It will happen again and again. The government will put people out of business. But more will take their place."

The Better Business Bureau has also joined the fight against false claims. It has set up a media alert that asks newspapers and TV stations to request substantiation from advertisers, proving the claims of fuel savings. The media are asked to request EPA results from the advertisers. **E**

Wanted: real gas-savers

The EPA told PS that it wants to encourage the development of gas-saving devices and is willing to test any offered for evaluation—after developers have first submitted their devices to an independent lab for testing. On the basis of those test results, the EPA will decide whether to test the devices itself. It costs about \$3000 per car to fully test the gas-saving devices in a private lab, the EPA claims. Developers can get more information by writing to Director, Emission Control Technology Division, U.S. Environmental Protection Agency, 2565 Plymouth Rd., Ann Arbor, Mich. 48105.

Shoppers' Showcase

A selection of products and services for Popular Science readers available direct by mail. Enjoy the fun and convenience of mail order shopping. Please order directly

from the advertiser. For advertising rates for this section, write Harry Fleischman, Popular Science, 380 Madison Avenue, New York, N.Y. 10017.

Custom Quality FOLDING SPORTSMAN'S KNIFE

An outdoor Pocket Knife with features worth four times the price.

HANDMADE STYLING
 • Solid Brass Bolster & Lining
 • Rosewood Handle
 • Sharp Surgical Steel Safety-Locking Blade

Only **\$4.50** plus 50c postage & handling
 Add \$2 for Genuine Leather Holster



EGBERT CO., Dept. AA
 11055 Sunset Blvd.
 Los Angeles, CA 90049

CHECK IT OUT!

There are more opportunities, products and services offered in the "Classified Opportunity Mart," immediately following this section. You may find just what you've been looking for.

Mail coupon plus \$6.00 and we'll give you a

Sight & Sound Introduction to the Most Advanced Do-it-Yourself Organs

You'll get a Wersi Demo Package—the LP "Wersitime 2", plus a 104-page full-color catalog. The quality recording and literature introduce Wersi's complete line of build-it-yourself keyboard instruments. Your first step into a sound hobby!

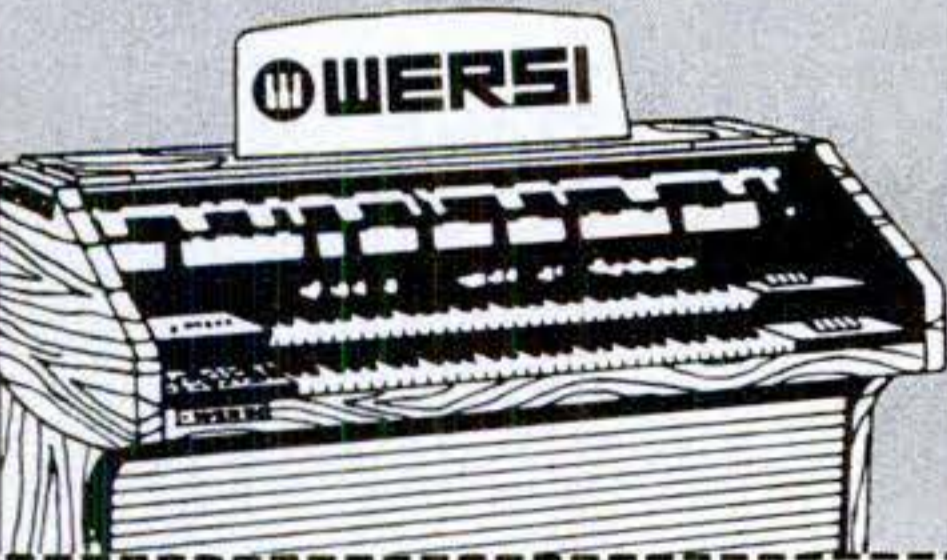

Wersi Electronics, Inc. Dept. 31
 1720 Hempstead Road
 Lancaster, PA 17601

Wersi Organs & Kits Dept. 31
 14104 E. Firestone Blvd.
 Santa Fe Springs, CA 90670

Enclosed is \$6.00 for my Demo-Package (LP with 104-page color catalog.)

Name _____
 Address _____
 City _____ State _____ Zip _____

DOME HOMES

Build your geodesic home from our complete, fully engineered kit... or use our plans and steel hub system!
 Catalog, \$3.
 Timberline Geodesics
 2015 Blake
 Berkeley, CA 94704

HIGH FLYING THRILLS!

ROLL-O-KITE

The amazing rotating airfoil causes strong lifting forces in the wind. A GREAT FLYER! Quick, easy to assemble without glue or tools. 17" wide, 7" diameter. COMPLETE KIT includes fittings, instructions, 100 yards of flying string — all handsomely boxed for gift giving.

\$5.00 sent each prepaid

The unusual design of this rapidly spinning airfoil causes strong lifting forces in the wind. A GREAT FLYER! Quick, easy to assemble without glue or tools. 17" wide, 7" diameter. COMPLETE KIT includes fittings, instructions, 100 yards of flying string — all handsomely boxed for gift giving.

\$5.00 each, 3 for \$13.50, 10 for \$25.00
 Calif. residents add 6% tax

Hawaii, Alaska, Puerto Rico, Mexico, Canada & any USA rush orders, add \$1.50 per order for air shipment. All other countries: minimum order 10 for \$30.00 — boxed & shipped by sea, prepaid.

Send check or Money Order to:
RAFCO, Dept. PS-30
 3136 Kashiwa St., Torrance, CA 90505

GARAGE DOOR OPENERS

• Radio Controlled

- Buy Factory Direct and Save
- Thousands In Use • Free Brochure
- Easy Homeowner Installation
- Immediate Shipment by UPS or PP

HELPMATE Equipment Co. Dept. PS-380 Baroda, MI 49101

MINI-BIKE FRAME!

BUY YOUR OWN MINI-BIKE FRAME

NEW! **for less \$30!**

ACTUAL PHOTOGRAPH!

Save Over \$60... Order Factory Direct!
 Now you can buy your own complete mini-bike frame for only \$19.95 complete with brake. Front fork only \$9.95. NO WELDING is required! NEW Plans, only \$1, reveal step by step details. Bolt together your own mini-bike in hours. Ideal for FUN!

- Mini-bike plans \$1.00
- Frame (with brake) ... \$19.95
- Front Fork complete ... \$9.95

FRAME (with brake) \$19.95 only \$9.95

PLANS only \$1
 Money back Guarantee.

Send cash, check or money order to:
BIRD, Omaha, Nebr. 68134
 Box 34422, PS-3,
 Name _____
 Street _____
 City _____ State _____ Zip _____
 Prices are FOB Omaha, Nebraska

The Amazing Stirling Cycle Hot Air Engine

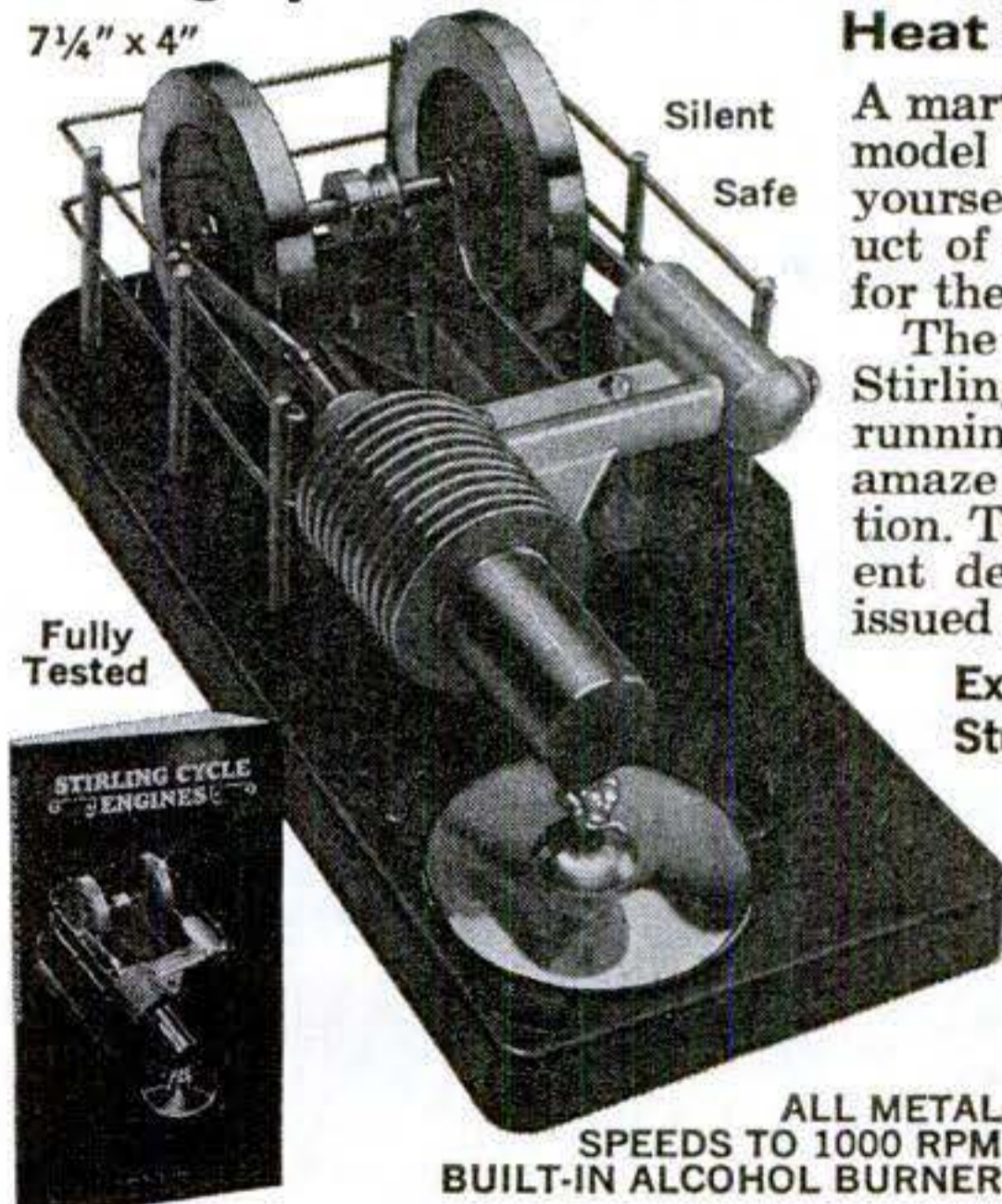

Heat is the only fuel required!

A marvelous opportunity to acquire an early model Stirling Cycle Engine and acquaint yourself with little known facts about a product of the past that may well hold promise for the future.

The average person has never heard of the Stirling engine, so the sight of one quietly running with heat as its only fuel will at first amaze them and then excite their imagination. This is the first in a family of six different desk-top model hot air engines to be issued during the next three years.

Experimenters • Hobbyists' Power Source Students • Collectors • Model Engineers

An easily read, lavishly illustrated, 128-page book accompanies each engine or may be purchased separately. This publication, the first of its kind, takes the reader on a 160-year tour through the world of Stirling Cycle Engines. Illustrations include the Stirling, Roper, Heinrici and the amazing new Stirling-powered Ford Torino!

Solar Engines • 2937 W. INDIAN SCHOOL RD., PHOENIX, AZ 85017 U.S.A. (602) 274-3541

Enclosed: PS Please send me: _____ Engine and Book @ **\$38.50** ... \$ _____
 Check Money Order _____ Book (separately) @ \$ 5.50 ... \$ _____
 Charge My: _____
 American Express VISA _____
 Diners Master Charge _____

(Domestic shipments sent postpaid. International (airmail) please add: \$11.00 for Engine; \$2.00 for Book only.) TOTAL \$ _____

SIGNATURE _____
 INTERBANK NO. _____ NAME (PLEASE PRINT) _____
 CARD NO. _____ ADDRESS _____
 EXPIRATION DATE _____ CITY _____ STATE _____ ZIP _____

CREDIT CARD BUYERS DIAL: (800) 528-6048

APPROVED FOR VETERANS

Learn how to MAKE MONEY in DRAFTING

Train at home in spare time. No previous experience needed. Tools and materials included with course. No special talent required. We show you what to do, how to do it. **LEARN DRAFTING AT HOME!**

FREE! "CAREER KIT"

NAME _____ AGE _____
 ADDRESS _____
 CITY _____ STATE _____ ZIP _____

Accredited National Home Study Council

NORTH AMERICAN SCHOOL OF DRAFTING
 4500 Campus Dr., Dept. PC020, Newport Beach, CA 92660

BEAT Inflation ... and HIGH Lumberyard Prices!

ONE MAN SAWMILL

Portable Belsaw goes right to the trees — turns out smooth, true-cut lumber every time. No experience required. Saw your own logs or lumber for others and make excellent sparetime income—no crew is needed. For power, use tractor PTO or other low HP diesel or electric unit. A size to meet every requirement and pocketbook—time payments may be arranged.

Send postcard for FREE details! No Obligation • No Salesman Will Call

BELSAW MACHINERY Co., 3145 Field Bldg. Kansas City, Mo. 64111

NOW! Turn Trees Into Valuable Lumber!

LENAIR

WASTE OIL HEATER

For Shop, Garage, Warehouse and Farm

Waste Oil Worth 80¢ per gallon as a heating fuel.

Pay Yourself not the fuel companies. Heat with any type of waste oil. LENAIR Waste Oil Heaters are a smart investment. Models 75,000 and 130,000 BTU Forced Air.

PROVEN • SMOKELESS ODORLESS

WRITE
LENAIR INDUSTRIES INC.
 P.O. BOX 1017-D
 JANESVILLE, WI 53545
 DEALER INQUIRIES WELCOME

Free! Edmund Scientific Catalog

Edmund Scientific Catalog

Explore Astronomy, Biofeedback, Optics, Lasers, Magnets, Weather, Magnifiers, Microscopes, Photography . . . Over 4,000 Fascinating Products in Our **FREE** 100 page color Catalog! Send for your **FREE Edmund Scientific Catalog, Today!**

38 Years Of Service!

Acclaimed in Europe Now Here . . . Everybody's chair

Adjusts instantly by fingertip control to

- fit everyone's shape and size
- fit all worksurfaces, desks, data terminals, drafting tables, switchboards, etc.
- relieve fatigue caused by incorrect sitting positions
- adjust from 16½" to 21½" or 20" to 27"

upholstered in tangerine, midnight blue or black—companion stool with optional backrest—footring optional

Save 75% by purchasing through this direct mail offer. Satisfaction guaranteed.

Please ship as follows:

| QTY. | MODEL | PRICE | AMOUNT* |
|------|------------------------|---------|---------|
| I | Chair—5" adjustment | \$79.75 | |
| I | Chair—7" adjustment | \$89.75 | |
| II | Stool—5" adjustment | \$59.15 | |
| II | Stool—7" adjustment | \$69.15 | |
| | Upright stool backrest | \$15.00 | |
| | Footring | \$15.00 | |

*Add \$5 per item for shipping and handling. North Dakota residents, add 3% tax.

NAME _____
 STREET ADDRESS _____
 CITY _____ STATE _____ ZIP _____

CHECK ENCLOSED MASTER CHARGE VISA

CREDIT CARD # _____ EXPIRATION _____

FURNIPA INC. P.O. Box 867
 Minot, North Dakota 58701

TV TO STEREO SOUND ADAPTER

GET SIMULATED STEREO SOUND FROM YOUR TELEVISION!

TELEDAPTER® easily connects to your own TV and stereo system to give you full rich simulated stereo sound through your amplifier and speakers. TELEDAPTER'S electronic circuitry matches the impedance between your TV and stereo amplifiers' aux., tape, or tuner input, while completely transformer isolating the TV's & stereo's chassis, for safety. The matrix circuitry provides two channels of output that plug directly into your stereo. Those ballgames and movies will never be the same after you hear the realistic thundering sound. Only \$19.95 postage paid, complete with hookup instructions, 2 year warranty.

To order: Enclose check • VISA or MasterCard # _____
 Expiration Date _____ Bank # _____
 NAME _____
 ADDRESS _____
 CITY _____
 STATE _____ ZIP _____

RHOADES Dept. PS - P.O. Box 817
 Hendersonville, TN 37075
 NATIONAL CORPORATION (615) 824-1735
SATISFACTION GUARANTEED OR YOUR MONEY REFUNDED.
 SEND COMPLETE CATALOG

QUARTZ BATTERY CLOCK MOVEMENTS

NEW LARGER SELECTION at the Lowest Prices Ever From KLOCKIT

PR Quartz series
 PR#202 - for dials up to ¼" thick.
 PR#203 - for dials up to ⅜" thick.
 Prices: For 1 Mvt. \$8.75
 5 mvts. \$8.00 ea.,
 10 Mvts. \$7.50 ea.
 Free Hour & Minute Hand!
 Second hand S-300 — 35¢ ea.

- Pendulums!
- Dials!
- New "Mini-Quartz"
- Numerals!
- Chime Movements!
- Wt. Shells!

Add: Shipping & Handling!
 1 unit \$1.50, 5 units, \$2.00

PHONE ORDERS WELCOME!

For complete Quartz series send for a Free Catalog - Write KLOCKIT, Dept. S-2, P.O. Box 629 • Lake Geneva, WI 53147 or Call: [414] 248-1150 [For 1st class catalog delivery - send 50¢]

START MAKING CHEAP "HOMEMADE FUEL."

STOP WASTING MONEY ON GAS.

Step-by-step instructions how to:

- convert your car's engine to operate on alcohol.
- produce your own cheap "Homemade Fuel."

Send only \$10.80 for the "Homemade Fuel" Book.

SEGO ENERGY

Box 1290B Palisade, Colorado 81526

ECONOMY WITHOUT COMPROMISE!

BACKPACKER VEST
KIT PRICE: \$24.95
(PRIME GOOSE DOWN);
\$17.95 (POLYESTER)

The Backpacker Vest, designed for rugged use, is just one of over 150 money-saving, high-quality kits from FROSTLINE. Complete money back guarantee. Tents, bags, packs, even hunter's clothing are offered at 30%-50% savings! All parts included ... even the thread. High quality and savings ... who could ask for more!



WRITE OR CALL TODAY!

Frostline kits

Dept. PS030
Frostline Circle
Denver, Colo. 80241
Phone 303-451-5600

**FREE
CATALOG**

STOPS YOUR ARTHRITIS WORRIES!

If you suffer from the pain of arthritis, rheumatism or backache here is good news.

MYKON gives fast ... longer lasting ... temporary relief from pain!

No more must you rely on ordinary headache remedies to get pain relief. Instead get MYKON capsules especially formulated for one sole purpose—to get you quick, reliable relief from the minor aches and pains of arthritis, rheumatism, bursitis, lumbago.

MYKON capsules are offered on the most binding guarantee imaginable! They must do everything promised or your money back without question—you don't even have to return the unused capsules. To order MYKON capsules send your name and address with \$8.95 for 100 capsules—(save \$1.95) 200 capsules only \$15.95 to:

AUER LABORATORIES—
Dept. PS30
3901 North Meridian,
Indianapolis, Ind. 46208

Now you can cash in on the huge demand
for SHARPENING SAWS and TOOLS.

BE
YOUR
OWN
BOSS!

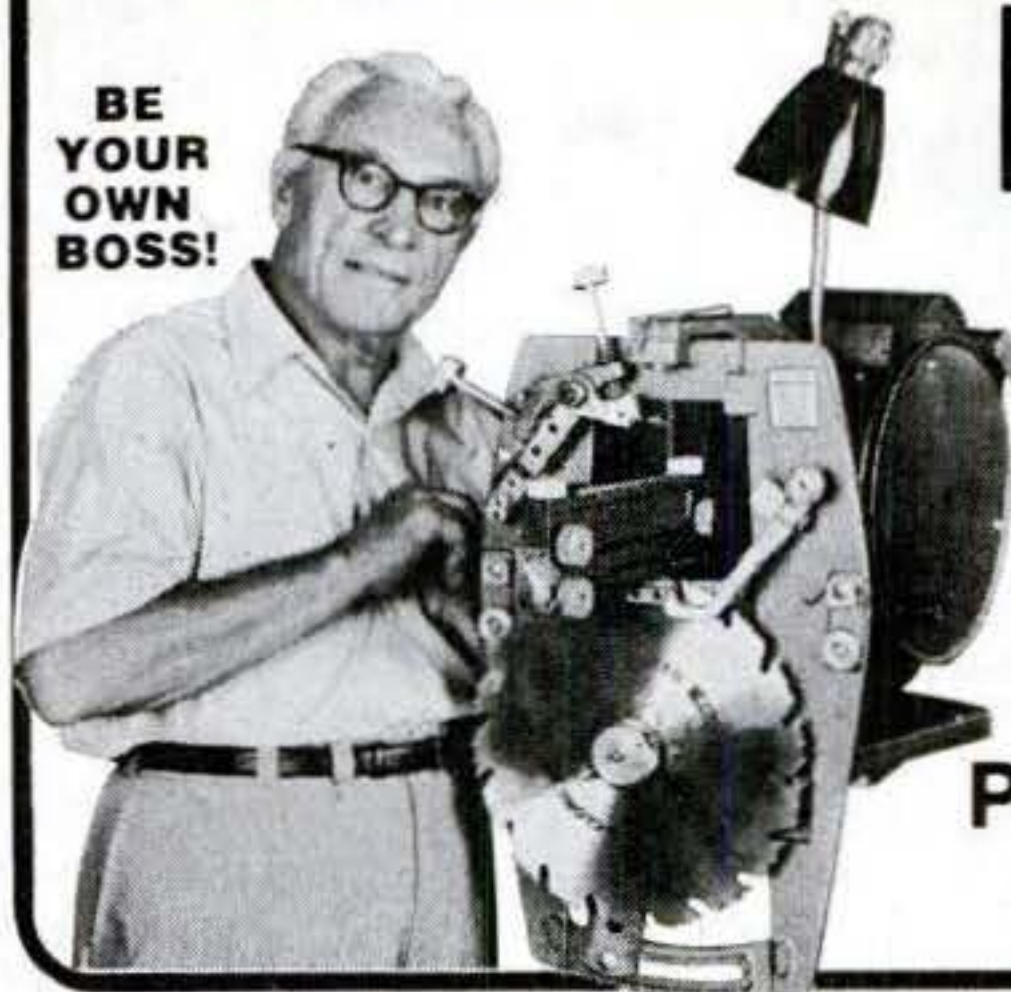

Make \$8⁰⁰ an hour...

or more. Work part time,
full time, right at home.
No layoffs. No strikes.
Provides a steady source
of year round income.

This can be one of the most important decisions you ever make
Going into business for yourself can be the most exciting and rewarding decision you're likely to make in your lifetime.

Owning your own business brings you a sense of independence. You're the boss, setting your own work hours. Your own effort builds the business for yourself and your family. You can achieve great satisfaction and profits, if you choose and manage your business wisely. That's why so many men, just like you, are cashing in on the big profits to be made in this fast-growing service field.

The sharpening business allows you to get started with only a minimum investment, requiring little space and effort for a successful operation. It lets you build and expand as fast, or as slowly as you like. You pocket most of the money you take in, because there are exceptionally high profits with no investment in merchandise.

If you need only \$200 or \$400 extra income each month, a sharpening business is ideal for spare time. The additional dollars can be SPENT for more of the good things of life. Or they can be SAVED in a rainy-day fund that the family can bank on.

More sharpening businesses are needed every year

As original equipment continues to climb in cost, owners are becoming more concerned that the equipment be maintained so that it performs like new. This means more companies, contractors, carpenters and home owners are having their old saw blades and tools resharpened many times, where in the past, they would have replaced them with new blades or tools. This is where you

can step in with the much needed service of sharpening saws and practically any kind of tool.

SEND FOR FREE FACTS TODAY!



This FREE booklet has helped thousands

Thousands of good men have been inspired by this fact-filled book into making that first important step of starting their own

business. It can be yours just for the asking.

It covers these important subjects...

- How much money can you make
- Age, education not a factor
- No selling is required — customers bring their business to you
- Lawn mowers and chain saws
- Sharpening business is year-round
- Sharpening opportunities in small towns and large cities
- A sharpening business provides excellent retirement income
- How Foley helps you start
- No experience needed, any age can succeed

Act today, so you can have a brighter, more secure tomorrow

Right now, while this is still fresh in your mind, fill-in the coupon below. We will send your FREE copy of "Opportunities in a Sharpening Business of Your Own". There is absolutely no obligation and there are no franchise fees in starting your Foley Sharpening Business.

Send your name and address to: Foley Manufacturing Co.
3226 Foley Building, Minneapolis, Minnesota 55418



FREE BOOKLET

This little book has helped change the lives of thousands of good people, just like you. Just complete the coupon, clip it out and mail it to us today. Get started now for a brighter, more prosperous tomorrow!

24-HOUR ANSWERING SERVICE
CALL TOLL FREE 1-(800)-328-7140
(Except in Hawaii or Alaska)

RUSH COUPON TODAY!

Foley Manufacturing Company
3226 Foley Building
Minneapolis, Minn. 55418



YES, I would like to receive complete details about how I can easily start a profitable, Foley-equipped sharpening shop. Please rush me your FREE booklet, without any cost or obligation, that gives me full details on how I can quickly start my own business.

NAME _____

ADDRESS _____

CITY _____

STATE _____ ZIP _____

**BUILD IT,
DRIVE IT...
AND SAVE!**



**ONLY
CRAWLER
TRACTOR
IN KIT FORM**

**Mini-Dozer® Saves —
and Earns You Money!**

**Popular, Low-Cost
MINI-DOZER KIT**



**New, All-Gear
MAGNATRAC KIT**

Your work hours are valuable. Use crawler tractor traction to get jobs done fast despite ground and weather conditions. Easily assemble Struck Kit on weekend (why pay others?) and use year 'round. Heavy-duty attachments include moldboard plow, dozer blade, snowblower, back hoe, tiller, front-end loader. Buy factory direct (and save!). Odd jobs for track-type tractors can mean extra cash. Resale opportunities are GREAT. Highly maneuverable Mini-Dozer is 7 to 16 hp.; 16 hp. Magnatrac goes 4 speeds forward, 1 reverse. Send coupon today

STRUCK KIT, Dept. PS30 Cedarburg, Wis. 53012

Catalog showing Struck Tractor Kit construction & uses (specify Mini-Dozer or Magnatrac) — 50¢. Both catalogs — 75¢.

Plans for fabricating Struck Tractor (specify Mini-Dozer or Magnatrac) from local materials — \$7.00. Both plans — \$10.00 (Refunded on any purchase.)

Name _____
Address _____
City, State, Zip _____

(DEALER INQUIRIES INVITED)

Never Lose A Tool Again...

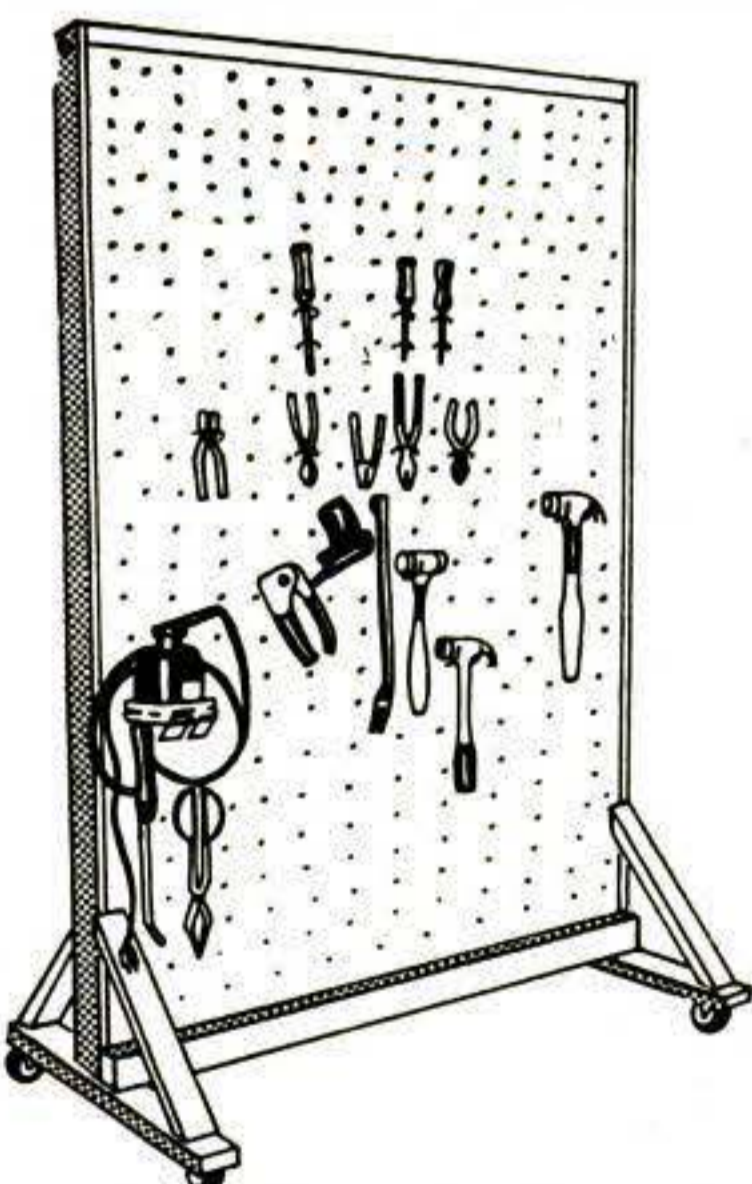

With Toolie (A Handyman's Valet)

Eliminate wasted time digging in tool clutter. Toolie is mobile and works where you work. Your exact tool is always handy, leaves you more time to work on your craft project. Easy to build. Your Toolie will help you spend your craft hours pleasantly while allowing more space to work in. Completely versatile. Toolie keeps tools stored compactly and ready to work. Send for your Toolie (a Handyman's Valet) plans today. Only \$5.00 postpaid.

Mail To: Beyon Cabinetry
P.O. Box 694 Dept. PS
Draper, Utah 84020

NEW! SAVE!

Assemble our Mansize DAHLCO Crawler Tractor Kit. Buy factory-direct. Catalog of Kit construction and uses - 50¢ "Build-it-yourself" Plans — \$7.00 (refunded on any purchase)

DAHLCO Dept. PS30 Cedarburg, WI 53012



GREAT OUTDOOR FUN.

SEARCH ELECTRONICALLY FOR . . . gold, silver, coins and relics with White's Electronics mineral/metal detectors. Pays for itself. U.S. Patented.

For your nearest dealer and free catalog
CALL TOLL FREE 1-800-547-6911

White's Electronics, Inc. Dept. PB-O Sweet Home, OR 97386



AUTO PARTS WHY PAY \$14 TO \$20 FOR REGULATORS

WHEN YOU CAN BUY THEM FOR \$5.45

PARTS, TOOLS, CHEMICALS, ACCESSORIES, & MORE. KING PARTS WHOLESALERS
Send \$1.00 For Price Sheets 83 Washington Street PS
(refundable with order) Rensselaer, New York 12144 (518) 465-0335

BELOW WHOLESALE

SAVE HEATING DOLLARS HOT PIPES

Converts 38" of 3" flue pipe, 19" of 8" flue pipe into a finned heating radiator.
Installs in minutes, no tools needed.
\$6.95 plus \$9.95 shipping.

WIL-MOR, INC. Dept. C P. O. Box 30182 Cleveland, Ohio 44130 Ohio residents add 5% Sales Tax.



FREE! VENEERING CATALOG PLUS SIMPLIFIED IRON-ON INSTRUCTIONS

Announcing! Put wood veneer on a home iron and new hot melt glue sheeting! Fast & simple. Send for free instructions plus catalog of 101 varieties world's rarest veneers at reasonable prices. Special bargain starter offers included. **SAVE 25% hurry!**

BOB MORGAN WOOD, DEPT. PO2K80 1123 Bardatown Rd., Louisville, Ky. 40204

OWN your own MAIL ORDER Wholesaling Business

Part time or full time Home Business

Buy at Rock Bottom Below wholesale prices like these

| Item | Your Cost | Sell For |
|--------------------------|-----------|----------|
| Perfumed Pen Set | \$.85 | \$ 7.95 |
| 5 Pc. Cutlery Set | 2.25 | 9.95 |
| Genuine Bowie Knife | 4.20 | 14.95 |
| Chain Burglar Alarm | 1.50 | 4.95 |
| Butane Cigarette Lighter | 2.60 | 9.95 |
| AM/FM Radio | 7.95 | 29.95 |
| 11 Pc. Wrench Set | 6.60 | 19.95 |
| Velvet Framed Paintings | 2.63 | 8.95 |

No previous experience needed. Make Staggering Big profits immediately. Get orders by MAIL, party plan, flea markets, wagon jobbing, many more—we show you how.

Choose from over 2500 products that bring profits of 3 to 5 even 7 times your cost!

Write for Free Book

Specialty Merchandise Corp.
6061 De Soto Ave. Dept. 237-87
Woodland Hills, CA 91365

Name _____
Address _____
City _____ State _____ Zip _____

WHAT'S HE DOING?

Making a Concrete Flower Pot! . . . and SO CAN YOU!



Make and sell your own Ornamental Concrete items. Rush \$5.00 for Book about Aluminum Molds with prices and production trade secrets direct from world's largest mold manufacturer. Over 350 designs to select from.

Send \$5.00 CONCRETE MACHINERY COMPANY

Today To → **P. O. BOX 899 - HICKORY, N. C. 28601**

Print For Profit

Cards; stationery; envelopes; advertising; labels; tickets; QSL cards; announcements; greeting, sympathy, prayer cards; tags, etc. Save money. **Own a Printing Business.** We supply everything direct from factory. Easy instructions. Also raised printing like engraving. Have home shop. Add to income. Send 25¢ for catalog.



Kelsey Presses, 80-CO Meriden, CT 06450

FOR SPEEDIER DELIVERY PLEASE USE YOUR ZIP CODE

If You Need **RUBBER** *Super Quick*

Anytime **STAMPS**
Day or Nite

CALL Toll Free 1-800-547-8678

MAKE MONEY! REPAIR HYDRAULIC JACKS

Earn while you learn at home. Millions of jacks in gas and auto service stations, trucking firms, body shops, riggers, factories and farms need servicing . . . most of which you can learn to repair. We show you HOW. Start spare time in your basement or garage. Big opportunity for mechanics. **ACT NOW!**

Write for folder No. P53 and free bonus offer

Hydraulic Jack Repair Manual Co., Inc.
P. O. BOX 7 - STATEN ISLAND N.Y. 10314



Splits **THE BOSS LOG SPLITTER!**
EASIER & FASTER!

Only \$49.95 plus \$5 p. & h. for adaptable cone, or \$99.95 plus \$8 ready-to-attach to hub of car or light truck (specify vehicle). Pa.—send 6% sales tax. Free info—send stamped self addressed envelope. **Good Products, Route 3 Box 88-A PS, Kutztown, Pa. 19530**



BUILD YOUR OWN HI-PRESSURE WASHER

SAVE! AS LOW AS \$169⁰⁰

WHILE THEY LAST! WE ACCEPT MASTER CHARGE AND VISA COMPLETE KIT AVAILABLE. INCLUDES HIGH PRESSURE PUMP, GUN, HOSE, SOAP INJECTOR, ETC. MOTORS AVAILABLE.

SEND FOR FREE PLANS.

KIM MFG. 2555 S.W. BLVD., K.C., MO. 64108 DEPT. PS



SINCE 1954

NEED THREE PHASE POWER

The "THREEPHASER" allows you to operate three phase motors 1/4 thru 7 1/2 horsepower from 220 volt single phase power sources. Rugged — heavy duty — patented unit built to give many years of satisfactory service. Satisfied users worldwide since 1966. Free literature furnished on request. Telephone 305-862-3038.

ONLY \$59⁹⁵

RELIAANCE ELECTRIC MANUFACTURING COMPANY INC.
Rte. 2, 1024 W. Lake Brantley, Maitland, Fla. 32751

STAINED GLASS

Send 50¢ for fascinating catalog of kits, tools, ideas, books, and supplies.

BIG STARTER KIT Only \$18.95 ppd.

WHITTEMORE, Box 2065DE, HANOVER, MASS. 02339



SAVE YOUR GAS... let your mail do the shopping

110 VOLT A.C. GENERATORS

60 cycles, 3000 watts. Wt. 27 pounds, 5"x10" Fan-belt driven from car or pickup. Operates T.V. All power tools. Over 17,000 in service. This is our 30th year. Guaranteed 6 months, \$169.00 Our X1200-watt generator needs no battery. Special Price \$159.00. Add \$6.50 for postage & handling, per unit.

VIRDEN-PERMA-BILT

Box 7160PS, 2821 Mays, Amarillo, TX 79109
Phone: 806/352-2761

The clockbuilder's choice.



Send today for our New Free Catalog of the most magnificent heirloom quality antique reproduction clocks you can build.

Your choice of Grandfather, Grandmother, wall, mantle, desk clocks and more. Available from plans or ready-to-assemble kits for all levels of skill. With solid 3/4" hand-matched hardwoods in walnut, oak, cherry or Honduras mahogany. Imported precision movements and chimes. Solid brass dials plus tools, hardware, books and accessories. You've never seen a finer catalog. You'll never build a better clock.

Please send me your Free 32 page color Catalog. I enclose \$1.00 for postage and handling.

Name _____

Address _____

City/State _____ Zip _____

Mason & Sullivan Co.
Dept. 1317 Osterville, MA 02655

TURN ON LAMP FROM HERE OR THERE



\$14.95

No installation. Just plug GENIE SWITCH module into an outlet which is already controlled by a wall switch. Any lamp (not incl.) plugged into module can now be switched either on or off by either the wall switch or the GENIE SWITCH. Save steps and bother. Ideal for bedside lamps. Money back guarantee. Patent pending. Post paid in U.S. (except C.O.D.) for a limited time. Lief, Inc., op-11, P.O. Box 12, St. Davids, PA 19087.

Be an ELECTRONICS SPECIALIST

No previous experience needed. LEARN AT HOME IN SPARE TIME

Now the same home-study training used by some of the country's biggest corporations for their own employees is available to you. Everything explained in easy-to-understand lessons with plenty of pictures and drawings. Get free facts about basic electronics programs that can lead to an exciting career in communications, TV and radio, manufacturing, computer industry and more. No obligation. No salesman will call. State age. Write: 601

ICS Electronics School, Dept. PC020, Scranton, PA 18515

Make Rubber Stamps for BIG PAY

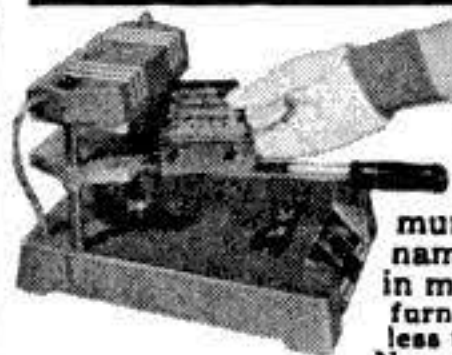

Need more money? Earn \$60-\$75 a week, spare time, at home making rubber stamps for offices, factories, individuals. Hundreds of uses. Hundreds of prospects—everywhere. Right in your own community. Turn out special stamps for names, addresses, notices, prices, etc., in minutes with table-top machine. We furnish everything and help finance you, at less than bank rates. Write for free facts. No salesman will call.

Rubber Stamp Div., 1512 Jarvis, Dept. R-3-JC, Chicago 60626

SLASH ENERGY COSTS!

Very Controversial Survival Publications (over two dozen) on Electric, Gas and Water Meters, Phones, TV, Guns and Ammo and Other Vital Topics, including Monthly Newsletter. By John J. Williams, M.S.E.E., as seen on CBS "60 Minutes" (3-5-78). ONLY YOU CAN ASSURE YOUR OWN SURVIVAL! Send \$1 (apply to first purchase) for our Super Brochure to:

CONSUMERTRONICS CO.
P.O. BOX 475 ALAMOGORDO, NM 88310

UNIQUE SPORTS CAR KIT

for VW. Fun, Easy to Build...

Send \$3 for color catalog. Send \$29.95 for catalog, assembly manual, color chart, and dealer information.

Dealerships Available



Laser 917

Elite Enterprises Inc.
Dept. PS3-80
690 E. 3rd St.
Cokato, MN 55321

TILLER USERS...

Can your machine do all of this?

- ★ Handle with just ONE HAND.
- ★ EVENLY break, turn & till soil.
- ★ Shred vegetation without tangling.
- ★ Leave NO WHEELMARKS or FOOTPRINTS.

The TROY-BILT® ROTO TILLER-POWER COMPOSTER can do all this and more! That's why serious gardeners consider it the finest tiller available. See for yourself! For complete details, OFF-SEASON SAVINGS, and FREE 24-page booklet clip this and mail today to:



TROY-BILT® Tillers
102nd St. & Ninth Ave.,
Troy, N.Y. 12180

TROY-BILT® Roto Tiller-Power Composters
Dept. A-100
102nd St. & 9th Ave., Troy, N.Y. 12180

Please send the whole wonderful story of TROY-BILT® Roto Tillers including prices and OFF-SEASON-SAVINGS now in effect for a limited time. (Please Print Clearly)

Mr. _____
Mrs. _____
Ms. _____
Address _____
City _____
State _____ Zip _____

KIT CARS



Annual Buyer's Guide
160 Pages
Over 500 Photos



ASSEMBLE & DRIVE YOUR OWN FULL-SIZE SPORTS CAR

Beat the gas crisis in style! Giant fact-filled Buyer's Guide reveals over 110 full-size kit-built autos. Discover everything from 40 mpg roadsters to economical gull-wing GT's, energy saving electrics and more. You'll save thousands! This Supercatalog is packed full of Photos • Prices • Comparisons • How-to's • Tech Data • In-depth articles and more. FREE! Order today and receive valuable Newsletter of used kit car bargains.

★ 14 Day Money Back Guarantee ★

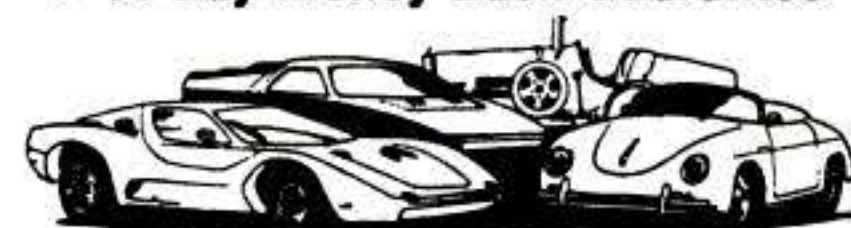

AUTO LOGIC, INC. \$7 Postpaid
P.O. Box 2073, Dept. C \$10 Rush 1st Class
Wilmington, DE 19899 \$11 Foreign Air Mail

Bill to my: Master Charge VISA

_____ Exp. Date _____
Name _____ (print)
Address _____
City _____ State _____ Zip _____



Order TOLL-FREE by phone.
Master Charge or VISA REQUIRED!
(800) 331-1000 Day or Night.
(918) 664-8300 in Okla. call collect.

Build this beautiful Dome Home by yourself!

The least expensive, most energy-efficient home available.



Monterey Domes' geodesic shell package can be easily assembled by one or two people in a few days with ordinary household tools. Our unique, patented system is a dramatic breakthrough—makes home construction a snap. No skills necessary. Your Monterey Dome home costs significantly less to build than a conventional home, yet meets or surpasses all building codes. It will also save you up to 50% or more on heating and cooling costs. Prices start at \$3795. Many home packages are available ranging from 700 to 4,500 square feet.



MONTEREY DOMES
Dept. 232 P.O. Box 5621 • Riverside, CA 92517

Please rush me your new 96 page full color Catalog and Plans Book. I am enclosing \$4.00.
 Also send me the Monterey Domes Assembly Manual for an additional \$5.00.

NAME _____
ADDRESS _____
CITY, STATE, ZIP _____
Mail To: Monterey Domes, Dept. 232
P.O. Box 5621, Riverside, CA 92517

DISCOVER BADGE POWER



Badge-A-Minit gives you the power to earn extra income by taking orders for pin-back buttons and badges. Clubs, political groups, schools, businesses and lodges have many needs for badges that promote their activities and identify members. With Badge-A-Minit, you create badges for all those needs with badge parts that cost just pennies each. Finished badges sell for much more!

Here's the lowest price ever for a complete badgemaking system. New starter kit includes sturdy Lexan die press; color-coded, BUT-N-LOK dies; quality, pin-back badge parts; and easy-to-follow instructions. Discover badge power for only \$17.95.



NEW LOW PRICE only \$17.95

**BADGE-A-MINIT, Ltd., Dept. PS-30
Box 618, Civic Industrial Park, LaSalle, IL 61301**

- YES, RUSH ME the Badge-A-Minit starter kit for only \$17.95 plus \$1.75 shipping, (Ill. res. add \$.90 tax)
- Personal check or m.o. enclosed.
- Use charge card below:
- VISA Mastercharge Am. Express Diners Club
- SEND ME FREE, the all color Badge-A-Minit catalog.

Credit Card # _____

Interbank # (MC) _____ Exp. date _____

Signature _____

Name _____

Address _____

City _____

State _____ Zip _____

UNCONDITIONAL MONEY BACK GUARANTEE



SAVE BIG!

BE INDEPENDENT!

Save Money: Buy complete kit — factory direct. Assemble in a weekend — use year 'round.

Earn Money: Make extra cash doing odd jobs — landscaping, snow removal, garden plowing, lawn care. OR, assemble kit and resell for profit.

Geared drive, 16 hp. engine, 30 attachments.



Send today:
CATALOG — showing kit construction and uses \$ 50
PLANS — for fabricating tractor from local materials \$ 7.00
 (refunded on any purchase)

STRUCK - KIT., Dept. PS30T Cedarburg, WI. 53012

INVENTORY ADJUSTMENT SPECIAL!

PILOT'S GLASSES AT UNBELIEVABLE PRICES!



ONLY \$6.95

- Impact Resistant
- Handcrafted
- Polished Glass Lenses
- Hardened Metal Frames
- Money Back Guarantee

To order, send check or money order (include \$1.00 for postage and handling) to U.S. Optics, Dept. 308, P.O. Box 14206 Atlanta, GA 30324. (Please specify gold or silver frames.) SPECIAL: Order now and get TWO PAIR for \$13 plus one dollar handling charge.

FREE! During this limited offer. Deluxe velour lined protective case. A \$3.00 value.
LIMITED OFFER FROM U.S. OPTICS

solar saves

The World's Largest & Most Comprehensive Buyers' Catalogue of Solar Energy Products! State of the Art Solar Products, Ideas and "How To" Information on Solar Principles, Installation and Tax Credits & Advantages. An exciting, Giant 350-Page Money-Saving Sourcebook! Send For Our Catalog Today.

**Credit Card Buyers . . .
 Call Toll Free (800) 537-0985
 In Ohio Call (419) 937-2226**

Now Only \$5.00



Solar Sourcebook

YES! Enclosed is my check or money order for \$5.00. Send me the Peoples' Solar Sourcebook.

Name _____

Address _____

City _____ State _____ Zip _____

Mail to: Solar Usage Now, Inc.
 450 E. Tiffin Street
 Department B-3
 Bascom, Ohio 44809

BE A CHIMNEY SWEEP

Your Own Business: A chimney sweep can clean a chimney with the August West® System in one hour. Nationally, the average charge is \$40.00.

A Growing Need: The energy crisis has resulted in a dramatic increase in wood burning. Wood smoke deposits flammable creosote in chimneys. Regular cleaning is necessary to prevent fire damage.

The August West® System: More sweeps use it than any other method in the country

Send for our free booklet, or call TOLL FREE any time and ask for "The August West Story."

800-648-5311

(In Nevada (800) 992-5710)
August West Systems, Inc.
 Box 603 — Dept. QMO
 Westport, CT 06880



THE WORDEN SYSTEM SECTIONAL LAMP SHADE FORMS

Simple - unique - construction method. Make beautiful Tiffany style lamp reproductions. Over 70 ANTIQUE Designs. At most stained glass shops. Big illustrated color catalog.

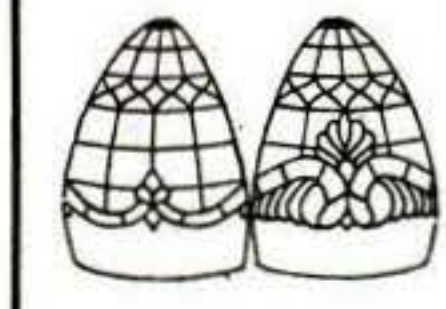

\$1.00 PPD (509)-854-1557
**H.L. Worden Co. PS 80
 P.O. Box 519
 118 Main Street
 Granger, WA 98932**

Learn Yacht Design

We have produced more yacht designers than any other school and we have been doing this for 50 years. At the same time we have also shown thousands of yachtsmen like yourself the satisfaction and sense of accomplishment to be gained in this rewarding study. And we do it all by correspondence.

- Accredited Member of the National Home Study Council.
 - Approved by the Connecticut Commissioner of Education.
 - Approved training for eligible veterans and service personnel.
 - A not-for-profit affiliate of Nat'l Marine Manufacturers Association.
 - SEND FOR FREE CATALOG.
- WESTLAWN SCHOOL OF YACHT DESIGN
 P.O. Box 779-J, Stamford, Connecticut 06904

Telephone Listening Device

Record telephone conversations in your office or home. Connects between any cassette or tape recorder and your telephone or telephone LINE. Starts automatically when phone is answered. Records both sides of phone conversation. Stops recorder when phone is hung up. This device is not an answering service.



Each \$18.95
 Qty. Disc. Avail.

Super Powerful Wireless Mic

10 times more powerful than other mics. Transmits up to 1/4 mile to any FM radio. Easy to assemble kit. 15V battery (not incl.)
 Call (305) 725-1000 or send \$18.95 + \$1.00 shipping per item to USI Corp., P.O. Box PS-2052, Melbourne, FL 32901. COD's accept. For catalog of transmitters, voice scramblers and other specialty items, enclose \$2.00 to USI Corp.



size 2"x3"x1/2"

New Tildan solar hot water heater



Save up to 80% of your energy cost. Utilizing collectors tested and evaluated by NASA and the U.S. Dept. of Energy. Send \$4.50 for full information, credited toward purchase of solar heater.

**Tildan LTD Inc.
 1338 Carson Salt-Springs Rd.
 Lordstown, Ohio 44485**

CLASSIFIED

OPPORTUNITY MART

1 AUTOMOBILES

LEGAL Alcohol Fuel 45c/Gallon! Solar/Conventional still plans. Mash formulae. Operate car, home. \$10.00—RDA, Box 873, Concord, NC 28025.

LECTRICAR—Convert VW's, Fiats to Electric 50 MPH. Plans \$25.00. Information \$1.00. Robert Bucy, Box 28794, Dallas, TX 75228.

GASOLINE MILEAGE INCREASED DRAMATICALLY! Details FREE! Toll-free recording, 1-800-446-8289 anytime. Techneering, Box 12191C, Norfolk, VA 23502.

100,000+ DEPENDABLE MILES by my proven method. \$4.00. Keller, 7009 Glenmeadow Lane, Cincinnati, OH 45237.

SAVE GAS, mileage tips, \$2.00. Box 19082, San Diego, CA 92119.

MY \$500 Electric Car. Patented: Build for Fun/Profit. Information \$5.00. Zuelco, 1320-A Dorchester Ave., Boston, MA 02122.

ALCOHOL—Complete Mash Recipes. Still plans and detailed do it yourself information on converting your auto to run on both alcohol or gasoline. Send \$5.00 to: Alcohol. P. O. Box 907, Los Banos, CA 93635.

MIRACLE CARBURETOR Vaporizes Gas 100+ MPG. Drawings, Details \$10.00. Money Back Guarantee. Carbu, Route 1A, Hitchcock, SD 57348.

GAS GADGETS DO THEY WORK OR NOT? Receive copy "GASAVERS Newsletter" Send \$2.00. Fuelexpanders, P.O. Box 17711, Irvine, CA 92715.

GASOHOL Latest homemaking guide, \$2.00. Gormett, 5133 Fairhill, Philadelphia, PA 19120.

PROPANE/GASOLINE DUAL-FUEL AUTO! Conversion plans and instructions. Parts sources. Only \$10.00! RDA, Box 873, Concord, NC 28025.

THE MILEAGE SHOP PRESENTS: One Stop Shopping for All Your Mileage Needs. Send \$2.95 today for our latest catalog to: **THE MILEAGE SHOP, INC.**, P. O. Box 4185-PS, Hayward, CA 94540.

BUYING A New Car? Save Money by having the Facts First. Send \$4.00 For Exact Dealer Cost Quote. List Make, Model. **CARS**, Box 262, Rt. 1, Port Hope, MI 48468.

NEW Car Every Year? Is It Possible? Free Details: Supercar, Box 28101-A1, St. Louis, MO 63119.

CORVAIR PARTS - 4500 Parts, 280 Page Catalog, \$3.25. Clark's **CORVAIR** Parts, Inc., Shelburne Falls, MA 01370.

ELECTRIC - Gas Combination 100 MPG, \$5.00. Homecraft, 2350 W47A, Denver, CO 80211.

GASOLIN SYSTEM POWERS VEHICLES on Woodgas! Replaces Gasoline! Guaranteed! Plans: \$5.00, Glenvale, Box 358y Station D, Toronto, Ontario M6P 3J9.

PROPANE Conversion, cars, trucks - Return to gasoline anytime while driving. Uses ordinary refillable cylinders. No engine modifications. COMPLETELY PROVEN, TESTED - THIS SYSTEM WORKS! No oddball surplus parts! Uses inexpensive LOCALLY available components. Build system yourself, for \$50, in two days with ordinary hand tools. Satisfaction ABSOLUTELY GUARANTEED or money IMMEDIATELY refunded. For plans, drawings, RUSHED First Class, send \$10.00. Fleming Engineering, Dept. PS7, Remsen, NY 13438

ALCOHOL - Oldest Fuel Comes of Age! **CONGRESS DEBATES IT, OIL COMPANIES RAPE IT, The People Get Shafted Again. Little Mechanical Ability Construct Your Own STILL from Discards. FULLY ILLUSTRATED, STEP BY STEP PLAN, Basic Lesson in Distillation/Mash Preparation. Plan Booklet \$7.50.**

STILL BOOK
P.O. Box 10475
Pittsburgh, PA 15234

1A ELECTRIC VEHICLES

GUIDE TO ELECTRIC AUTO CONVERSION. Comprehensive 58 page Manual. Includes proven Diagrams, Schematics, and Parts Procurement. Loaded with information!! \$13.95. Williams Enterprises (Dept. 1B3), Box 1548, Cupertino, CA 95014.

CLASSIFIED ADS \$5.50 per word, per insertion. Minimum 10 words. Payment with order, or charge to your Visa or Master Charge. First word in bold capital letters, rest of ad upper & lower case. Other bold cap words, \$1 per word extra. Bold headline or white space, \$22 per line. **DISPLAY-CLASSIFIED \$300 per inch, per month.** Advertisers using a P.O. Box number must furnish complete name and street address for our records.

CLOSING DATE for May issue (on Sale April 15) is February 27. Send orders to Mary C. Ansbro, Classified Adv. Mgr., Popular Science, 380 Madison Avenue, New York, NY 10017.

75 MPG!
Amazing Build-It-Yourself Hybrid Electric Car can travel at 90 MPH... Takes less than 40 hours to build... and costs just \$1500! Complete Plans (including schematics materials list and components sources) are available from **THE MOTHER EARTH NEWS**. Send Check or Money Order to:
MOTHER'S PLANS
Dept PS3C, P.O. Box A
East Flat Rock, NC 28726

2 AUTO SUPPLIES & EQUIPMENT

ALTERNATOR Generator Rebuilding Book. Details: Hedelund Engineering, 7505 Barkentine, Las Vegas, NV 89128.

FREE OIL and More. Auto Reports Show How. Five for \$2.95. Details, SASE. P & J, 17 Marion, Phoenixville, PA 19460.

SEE CLEARLY WHILE DRIVING - WITH RAIN-X
"The Invisible Windshield Wiper" Makes glass super-slick - disperses rain, sleet & snow on contact. Restricts frost & grime adhesion - makes removal a snap. Send now. Special offer: A year's supply - just \$8.95 postpaid; refund guaranteed.
Zaddock & Co. Inc.
Suite 1203-PS3, 180 W. Washington
Chicago, IL 60602.

WHEEL BALANCER \$15.00 TO \$50.00.
MONEY BACK GUARANTEE. for motorcycle cars and trucks. Detailed Information and Illustration Free.
JACOBSEN MFG.
P.O. BOX 68143
15025 Pac. Hwy. SO.
SEATTLE, WA 98188.
THE ROLL GRAVITY TYPE WHEEL BALANCER IS SENSITIVE, ACCURATE, SIMPLE TO USE.



3 AUTO TRAILERS & CAMPERS

R-V KITS - PLANS - PATTERNS - Campers - Trailers - Fifth Wheels - Vans - Covers - Motorhome. Simple construction. Save! R-V Kits / Equipment catalog \$1.00. **GLEN-L R-V's**, 9152-PS Rosecrans, Bellflower, CA 90706.

4 MOTORCYCLES, BICYCLES & SUPPLIES

Easy to Build PLANS
GO KART .. \$2.50
MINI BIKE \$2.00
THREE WHEELER \$3.00
MINI CAR \$3.00
PEDAL BOAT \$4.00
12' SAIL BOAT \$4.00
SAIL BOARD \$2.00
SOAP BOX \$3.00
8' HYDROPLANE ... \$2.00
2 People MINI JEEP \$3.00
THREE WHEELER A.T.V. \$5.00
SNOWMOBILE SLEIGH \$3.00
FRONT TRACTION GO-KART W/
GEARLESS DIFFERENTIAL \$10.00
8 H.P. TRACTOR \$10.00

MINI VEHICLES PLANS
Dept. A, Chazy, N.Y. 12921

5 AVIATION

HANG Gliding Handbook - \$6.95 postpaid. Poynter, Box 4232-F, Santa Barbara, CA 93103.

SPORTSPLANES, MINI-HELICOPTERS. MOTORIZED-HANGGLIDERS. Plans/Kits/Complete. Many types. Catalog \$3.00. LFP, Dept. C, Box 19828, Houston, TX 77024.

BOOMERANGS - INCREDIBLE RETURN! Exciting sport. Order Free catalog - Amazing designs! Boomerang-Man, 312 Park, Monroe, LA 71201.

ONE-MAN JET HELICOPTER - Easy, inexpensive to build! Detailed plans, drawings-\$7.00. **HELICOPTER EXPERIMENTER'S HANDBOOK**-\$4.00. Both -\$10.00. Helicraft, Box 3053-A, Redondo Beach, CA 90277.

POWERED GLIDERS by World's Largest Manufacturer. Over 900 deliveries world-wide! Proven, economical flying fun; no license required. **NEW!! Rally 1** with fully aerodynamic controls! Brochure \$5. Rotec Engineering SP3, Box 124, Duncanville, TX 75116.

HELICOPTER KITS: Gasoline and Jet Powered from \$495.00. Information \$2.00. BW Rotor, Towanda, KS 67144.

WEEDHOPPER-ULTIMATE FUN MACHINE!



No licenses required on plane or pilot; 40 hour construction time; complete kit \$2695; carries 220 lb up to 50 mph! Send \$5.00 for info-pak to:

WEEDHOPPER OF UTAH, INC.
Dept. PS3, Box 2253, Ogden, UT 84404

ROCKET PROPULSION SYSTEM



Build your own hot gas generator that propels you approximately 85 feet high at 60 MPH! Send \$10.98 for info-pack to:
PROPULSION
P.O. Box 2624
Arlington, Va. 22202

5A HOVERCRAFT

HOVERCRAFT Plans, Catalog \$1.00. Universal Hovercraft, Box 281, Cordova, IL 61242.

HOVERCRAFT Plans, Kits. Free Information. Fan-Tastic, Box 691, Renton, WA 98055.

AERO-CAR Amazing Hovercraft built easily with ordinary tools. Lawnmower engine powered. Carries one man plus. Flies over land/snow/water. Complete plans and booklet. \$8.95. Aero-Projects, Box 5118PS, Clinton, NJ 08809.

6 ASTRONAUTICS

ANTIGRAVITY Propulsion Device. Free Brochure, RDA, Box 873-N, Concord, NC 28025.

SPECTACULAR U.F.O. Hydrogen Powered using common ingredients. Instructions \$3.00. C. Hughes, 149 Mill St., Milford, PA 18337.

7 BOATS, INBOARD & OUTBOARD MOTORS

BOAT KITS-22 Trailerable models-**POWER** and **SAIL** - 16' - 30'. Molded fiberglass hulls and decks come factory assembled - you install factory supplied interior. Save half factory-built cost. No experience required. **FREE** Catalog. Luger, Dept. AC-80, 3800 West Highway 13, Burnsville, MN 55337. (612) 890-3000.

ELECTRIC Boats. Vantage Boats, 6332 Lakeview Drive, Falls Church, VA 22041.

EVINRUDE 1979 Bargains... all sizes... \$1.00 handling... Scott-McCulloch parts... Electra Marine, 610 Merrick Road, Lynbrook, NY 11563.

FIBERGLASS - RESINS - foams - glass - epoxies - mat - etc. Factory prices - Catalogue \$2.00 - (Book "Complete Fiberglassing" \$6.00). **CLARKCRAFT** - 16-S-1 Aqualane - Tonawanda, NY 14150.

BOATKITS - PLANS - PATTERNS - FRAMEKITS - 300 modern designs in plywood - fiberglass - steel - complete - instructions. **POWERBOATS** - inboards - outboards - cruisers - sportfishers - runabouts - hydroplanes. **SAILBOATS** - prams - daysailers - trailersailers - motorsailers. **KAYAK** - Canoes - Complete line fiberglass builders materials - Catalogue - \$1.00 (with Boatbuilding Guide - \$2.00). **CLARKCRAFT** - 16-S Aqualane, Tonawanda, NY 14150.

GAS SAVER DORY SKIFFS
Free Plan "Gloucester Gull" Rowing Dory With Brochure/Photos 50 Plans 15/45 Ft. Power & Sail Only \$2.00. Air Mail \$3.00. Texas Dory, Box 720, Galveston, TX 77553.

BOAT PLANS - FRAME KITS - PATTERNS - HUGE 140-page catalog! Powerboats - Sailboats - Outboards - Jets - Rowboats - Houseboats - Runabouts - Dorries - Workboats - Racing Boats - In plywood - Cold Molded - Wood/Epoxy - Fiberglass - 8' to 49'. Lowest cost, highest quality for 27 years. Easy, proven methods include instructions especially for amateurs. No lofting! **"BOAT-BUILDING SUPPLIES"** - Fastenings - Fiberglass - Resins - Glues - Equipment - Spars - Books - Boat Trailer Plans. Send \$2.00 for catalog plus **FREE "BOATBUILDING SUPPLIES"** brochure. **"INBOARD MARINE HARDWARE"** catalog also \$2.00.

GLEN-L Marine
9152 Rosecrans, Dept. SP
Bellflower, CA 90706

9 ELECTRICAL SUPPLIES & EQUIPMENT

JOURNEYMAN CREDENTIALS GRANTED LEGITIMATE! Write: National Craftsman Union, 210 Fifth Avenue, Suite 1102, New York, NY 10010

11 DO-IT-YOURSELF

LASER Handbook, or **ENERGY** Handbook - \$3.00 each. Famco, Box 1902, Rochester, NH 03867.

CONVERT Auto to Hydrogen operation! Generate hydrogen fuel. Plans and Instructions - \$10.00. RDA, P.O. Box 873, Concord, NC 28025.

ELECTROPLATING, Complete Textbook. All Metals. Electroplate Metallic/Nonmetallic Items. \$9.95, Details Free. Tropic, Box 95P, Palm Bay, FL 32905.

"FREE POWER"
The Bible of "Do It Yourself" Alternate Energy Projects. Written by experts. 11 tested projects, 139 pages, 44 illustrations. \$10.00 PP. Consolidated Energy Consultants, Sparks, MD 21152.

REVERSE Automobile starting motor for inexpensive motor to power winches, hoists, etc. Diagrams and instructions. \$5.00. Glendenning, R.D. #1, Box 94, Apollo, PA 15613.

DULCimers \$66, Kits \$27. Brochure. Here Inc, 29 Southeast Main, #S, Minneapolis, MN 55414.

REPAIR COLOR TV'S. Anyone can. Write: Publications, Box 517A, Brea, CA 92621.

UPHOLSTERING SUPPLIES, Fabrics, Vinyls, Tools, Cane, Instruction Books. Free Catalog. Jim Dandy Sales, Box 30377-S, Cincinnati, OH 45230.

ALARM SYSTEM against burglars for under \$10. Plans \$2.00. Box 161, Station St-Sauveur, Quebec, Que, Canada.

125 WAYS TO IMPROVE YOUR GAS MILEAGE! Latest Tips & Techniques On How To Increase Gas Mileage 15% to 25%. Instructions \$9.95 - Money Back Guarantee. Fuel Expanders, P.O. Box 17711, Irvine, CA 92715.

SKI, JOG to STEREO CASSETTE. Complete Plans \$5.00. Mecco, 12599 Europa, White Bear Lake, MN 55110.

VOLLEYBALL POLES, UNBENDABLE, Adjustable, No Guide Strings, 30 second setup. Hardware available. Details \$2.25. P. O. Box 141, Krakow, WI 54137.

MAKE Your Own 14th Century Wood Display **BATTLE-AXES.** Plans \$3.00. J-Kraft, P. O. Box 50217, Cicero, IL 60650.

EASY CLEAN DOG HOUSE!!! Build it yourself . . . do it right. Detailed instructions, \$2.00. Guaranteed. SunTex, Dept. P103, 2905 Regal, Plano, TX 75075.

ION GENERATORS. Outperform \$200 Models, Kit \$59.50, Complete \$79.50. Professional Ionizers, 204 N. Hydraulic, Wichita, KS 67214.

LEVEL EXACTLY LONG DISTANCES. . . . One to over 200 Feet . . . Yards . . . Lawns . . . Patios . . . Foundations . . . Excavations . . . **AROUND CORNERS!** Easy, New Product . . . \$24.95. Free Brochure. Cox Associates, 1372 Seville -MPS, Bountiful, UT 84010.

PROJECTION TV . . . convert your TV to project 7 Foot picture . . . Results equal to \$2,500 projector . . . Total cost less than \$20.00. **PLANS & LENS \$16.00.** Illustrated information **FREE.** Macrocoma F, Washington Cross-in, PA 18977.

SAVE \$\$\$ - SAVE ENERGY + TAX REBATE. Make your own thermo-insulated glass windows! Illustrated instruction booklet plus catalogue . . . \$2.95. Armour Corp., PS Hill, Midland Park, NJ 07432.

PAINT FORMULA Saves Money! Mix Permanent paint yourself from inexpensive materials, purchase at local stores and save 90%! Painter's complete simple instructions. Results Guaranteed. \$4.00. Order Now! Evans, 407 1/4 E. Broadway, Wetumka, OK 74883.

MOST COMPLETE Conversion Tables cover ALL Fields of Science and all measurements with over 900 conversions. **INCLUDES** Metric - Standard. \$1.00. W.I.-1, Box 630275, Miami, FL 33163.

WANT to build your own home? or Log home or vacation home? Perhaps your interest is in fireplaces, living rooms, kitchens—or landscaping, greenhouses. Books with basic information for do-it-yourselfers, covering variety of "Successful" projects. Free Catalog. Write: Structures Publishing, Box 1002, Dept. PS-3, Farmington, MI 48024.

FAS-N-EZY is today's tool for installing wall-fasteners (molly bolts) smoothly every time. \$6.98pp complete with instructions. Scandia Mechanical, 1106 5th Avenue South, Lake Worth, FL 33460, Dept. PS2, Visa, MasterCard accepted.

SOLAR HOT WATER HEATER Saves money & energy! Inexpensive, connects directly to existing hot water tank. Plans \$5.00. Sensor Systems, Star Route Bx. 35B, Del Norte, CO 81132.

LASER

LASER OR MASER PISTOL — Complete Plans for Building—\$2.75 each



INVISIBLE FORCE FIELD—\$2.00. MOON MAN ROBOT—\$2.00

SOUND LASER \$2.00

LASER COMMUNICATIONS \$9.95

MAGNETISM and its effect on the living system \$8.95

Catalog of super Science Projects—75¢.

WANTED: SCIENTIFIC PLANS!

JACK FORD SCIENCE PROJECTS
PO Box 948A, Duluth, GA 30136

SATELLITE TV FOR THE HOME



Our receiver lets you get over 75 channels of television directly from earth-orbiting cable TV satellites! HBO, Showtime, super stations, sports and movies from around the world.

Sick of Network TV?

Buy Complete or Build our kit and save!

Our 24-channel receiver provides "studio quality" TV reception. Easy to install! Ultra low power consumption! Brilliant color! Works anywhere! FCC licensing no longer required. Order today!

Complete details covered in our Home Earth Station manual. Send \$7.95 today (refundable against any purchase), or call:

24-hour C.O.D. Hotline
(305) 869-4283

SPACECOAST RESEARCH
Dept. Q, P.O. Box 442, Altamonte Springs, FL 32701

TEMPERATURE MEASUREMENT

100 pages of technical data, plus 100 pages of product information. Learn to measure any temperature from cryogenic to 5,000° F — in automobile engines, exhaust pipes, disc brakes, bearings; also kilns, furnaces, ovens, pipelines and much much more. Ideal for the hobbyist, the student, or research engineer.

Send \$5.00 check or money order to: **NANMAC Corp., Dept. PS**
9-11 Mayhew Street
Framingham Ctr., MA 01701
(allow 3 weeks for delivery)

LASERS UNLIMITED

- CONSTRUCTION PLANS — with all parts sources
- Ruby Laser Ray Gun \$15.00
- 40W Burning CW CO₂ Laser 15.00
- Argon Multi-color Laser 10.00
- Dye Tunable Color Laser 10.00
- Helium Neon Visible Red Laser 7.00
- Solid State Laser Rifle 8.00
- 100 KW Nitrogen UV Laser 7.00
- Beginners Pocket Visible Laser 7.00
- Laser Light Show Plans 9.00
- COMPLETE ITEMIZED LIST of all laser companies with addresses, phone numbers, spec sheets 6.00
- LISTING OF BOOKS, LASER COURSES, DATA SHEETS, INFO PACKS, NEW DEVELOPMENTS, GOV'T INFO WEAPONS, etc. 5.00

LASERS UNLIMITED
Dept. L1, Box 716
Amherst, NH 03031

SCIENTIFIC SYSTEMS INC.,

Now at last offers in kit or completed form such unique products as: Nighttime vision devices, super sensitive directional mikes, low and high powered lasers, micro-mini-voice transmitters, ultra sonic devices, super high voltage generators, intrusion and sensing devices, scientific personal protection items, and many other hard to find products. Send \$1.00 for catalog: **SCIENTIFIC SYSTEMS INC.** Dept. S1, Box 716 Amherst, NH 03031

PUMP

DRAIN • IRRIGATE
CIRCULATE • SPRAY



Heavy-duty rustproof ball-bearing pump. Stainless shaft. 1HP1200GPH 60" high or 3000 GPH 25" well. 5200 GPH max. 1 1/4" in. 1" out. Belt or direct drive. Use 1/4 HP or larger. Money back guarantee. Add \$2.00 shipping. **LABAWCO** Box 35, Belle Mead, N.J. 08502

FANTASTIC SCIENCE PLANS

Low-Cost/One-man Hovercraft \$7.00

Solid-State Laser 6.00

Easy-to-Build Jet Engine 6.00

Stereo-controlled Laser Show 8.00

Methane Fuel Generator 10.00

Convert Auto to Hydrogen/Methane . . 8.00

Generate Hydrogen Fuel 10.00

Electronic Robot 9.00

Visible-Red He-Ne Laser 6.00

Radiation Survey Meter 5.00

MHDElectrical Generator 5.00

25KV Tesla Coil 5.00

EXCLUSIVE MONEY-BACK GUARANTEE

CATALOG \$1.00

RESEARCH & DEVELOPMENT
Route 2, Box 322-A
Kannapolis, N. C. 28081

HOME ENERGY COST-SAVING PLANS

2000 WATT WOODBURNING STEAM TURBINE: Compact RADIAL TURBINE delivers up to 2000 watts of generated electricity! Ideal for homes, farms, cottages! Simple, Economical Construction! Enjoy FREE power! COMPLETE PLANS include boiler & battery configuration.

METHANE GAS GENERATOR SYSTEM: This simple generator produces FREE METHANE GAS for cooking, heating, lighting- even running vehicles! Uses ANAEROBIC DIGESTION to produce Methane from waste matter normally discarded! SAVES money in any home or farm! COMPLETE PLANS include many different application methods. **PLANS: \$6.95 each, both for \$9.95**

GLENSALE PRODUCTS, Dept PS3 Box 358 Station D Toronto, Ontario M6P 3J9

Wind/Methane Solar/Fuel Cells



Enjoy free heat & power. Send for energy Encyclopedia. Complete list of Mfg., cost, specifications, on most alternate sources of energy - Plus Catalog of Plans available for do-it-yourselfers. — \$4.00

Energy Service
14A Hughey St., Nashua, NH 03060

GENERATE FREE POWER



Cut heat and electric bills. Enlarged encyclopedic windmill/generator report gives sources, costs, instructions, capacities, specifications of equipment you can buy today. Only \$4.98. Also Henry Clews' authoritative Electric Power from the Wind: \$2.98. Both, \$6.98. And famous Dwyer precision, portable wind speed indicator: \$8.95. All three \$14.49. FREE with order: U.S. brochure Solar Energy for Heating and Cooling. Shipped in 2 days.

MONEY BACK GUARANTEE.
ENERGY UNLIMITED, Dept. 103
219 Thorndike St. Palmer, Mass. 01069

GREAT SAUSAGE RECIPES AND MEAT CURING

227 page illustrated book explains sausage making plus home curing and smoking of meat, fowl and fish. Over 100 recipes. Free equipment and supply catalog has more information. TO GET YOURS. SEND TO: **The SAUSAGE MAKER Dept. AC-3** 1067 Grant St., Bflo, N.Y. 14207

12 HOME CRAFTSMAN

CREATIVE Fun Building Child's Safe. Changeable Combination. Instruction \$4.00. Child, Box 166, Turlock, CA 95380.

"GETTING Started in Stained Glass" 50c. Whittemore, Box 2065X, Hanover, MA 02339.

1600 CATALOGS listed and described. Sources for everything imaginable, \$3.00. **MASTERLOG, Box 879** Fairfax, CA 94930

875-PAGE Catalog of Industrial Quality Products for home . . . workshop. \$3.00. GNG, Box 42550, San Francisco, CA 94142.

TOUGH QUALITY SANDPAPER. Save Big. Used by Leading Furniture Factories. Free Samples. While Supply Lasts. Weathering Springs, 230 Dora Highway, Pulaski, VA 24301.

WOOD! 40 Varieties Hardwoods! 4000 Items - Woodshop Tools, Supplies, Kits, Hardware. 152 Page 50th Anniversary catalog. 50c. Craftsman, Dept. BX-30, 1735 Cortland Ct., Addison, IL 60101.

13 TOOLS & MACHINERY

BANDSAW BLADES. Any Size. Free Pricelist. Bandsaws, 8921hy49, Sonora, CA 95370.

SMALL FOUNDRY Furnace, Supplies. Free Literature. Pyramid Products, Dept. M, 3736 South 7th Avenue, Phoenix, AZ 85041.

MACHINEX — Unimat—Maximat—Sherline Lathes, Mills. Catalog \$1.00. Shop Supplies \$1.00. Campbell, 1424 Barclay, Springfield, OH 45505.

4" METAL Cutting Lathe \$68.90. Taig, 15048 Proctor, Industry, CA 91746.

14 ENGINES & MOTORS

1000's ENGINES - Parts - Electric Motors. Atlantic Engines, 741 South Ocean, Freeport, NY 11520.

MOTOR HOLDER

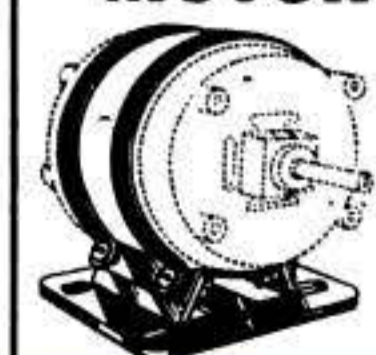

Puts firm base under end mounted motors 5-1/16 to 6-11/16 diameter.

Postpaid U.S. Prices—Aluminum \$3.25 ea./2 for \$5.50, 3 for \$7.25 - 6 for \$13.00. For all Steel add \$.25 each mount.

E. Walstedt Co.
11801 92nd Ave. N.
Osseo, MN 55369

15 HOME REPAIRS, REMODELING

HOMEOWNERS — Build your investment into a fortune. E-B Newsletter gives monthly facts and forecasts. Also "How To" catalog index. Free brochure. Equity-Builders Newsletter, Box 1541, Dept. A1, Brockton, MA. 02403.

15A ENERGY SAVING

SLOW DOWN YOUR ELECTRIC METER. It's perfectly legal. Details \$5.00. Arnesco, Box 1061-PS, Woodland Hills, CA 91365.

UNIQUE proven design using ashp for combustion air increases fireplace efficiency, keeps glass doors cleaner, reduces drafts. Blueprints, instruction \$7.50. Energy Engineering Enterprises. P.O. Box 518, Ucon, ID 83454.

HYDRAULIC RAM WATER PUMP
Use spring or stream water to pump water to house or cabin. Plans and instructions to build and install \$5.00. Dantonio, 2920 Maria Dr., Redding, CA 96001.

NO MORE FUEL OIL!
HEAT Entire home and domestic hot water on a handful of kindling. \$9.95 to: Box 154, Yaphank, NY 11980.

GET LATEST UNDERGROUND HOMES INFORMATION! Two new books, manual, blueprints. Free color brochure! Underground Homes, 70 Masonic Building, Dept. PS-3, Portsmouth, OH 45662.

HEATSAVER. Up to 40% Increase Efficiency. Use woodstove and oil furnace. Instructions \$2.98. 291 Shirley, Omaha, NE 68005.

ENJOY Year Around **SLEEPING COMFORT** . . . Save Fuel too! Write **COMFORTABLE, PS3, 9908** Armitage Melrose Park, IL 60164.

INSULATION FOR WINDOWS AND SOLAR PANELS Cuts night-time heat loss by 20% to 80%. Choice of three waterproof, lightweight material from 65c/sq. ft. For information and material samples send \$3.00 (refundable) to: Sensor Systems, Star Route Bx. 35B, Del Norte, CO. 81132.

HOT AIR CIRCULATOR



Put it behind woodburning stove to move hot air into living area. Can be used to pipe air upstairs from basement, or from room to room. All steel construction with fan & thermostat control. 60 WiFi fan. 40" HI x 30" WD x 10" DP

Send \$99.95 to

S.A.M. MFG. CO.
P.O. BOX 55, NESHKORO, WI 54960

15B ALTERNATE ENERGY

AMAZING Forced Air Wood Heater Supplement Your Furnace or Use Alone. Fiberglass Storage Tanks 100 to 8,000 Gallons. Write: Box 3, Rockton IL 61072.

ENERGY INTEGRATION - Book on Alcohol, Methane, Electricity, & Solar systems for homesite energy production. \$2.00. AlEnSy, Rt. 2, Box 43 San Marcos, TX 78666.

HYDROGEN - Electrolysis Generator Plans, \$10.00. L. Spicer, Lineville, IA 50147.

HEAT: Your whole house with improved barrel stove. \$3.00. Box 63 Circle Pines, MN 55014.

WIND powered generators, Practical inexpensive, compact. Available now! Details \$5.00. Parts Unlimited. 901 S Main, Normal, IL 61761.

"GO SOLAR" Bumper Sticker. Also "SPLIT WOOD NOT ATOMS" and "NO NUKES." \$1.00 each. Merchant, Box 990-S, Athens, OH 45701.

FREE Home Lighting, No Cost Electricity. Further Details: James West P.O. Box 1635, Pompano, FL 33060

DESIGN evaluation booklet on Solar Energy hot water systems \$3.00. J Magnano, Consultant, 48 Creeping Hemlock, Norwalk, CT 06851.

TRUE or False? 50 MPG carburetors. Box 206-8, Berea, KY 40403.

WIND POWER BLADES
9" DIAMETER, 3-Blade with Hub and Shaft: \$125. Begins producing in 8 mph, 3/4 HP in 17, 2 HP in 25 mph wind. Johnston Manufacturing 412 W. Sierra, Palmdale, CA 93550

MAKE POWER ALCOHOL FUEL. Information Packet Contains 128-Page Still Building Book, Testing Kit Literature, and More. \$6.00. Micro-Tec Laboratories, Inc., Rt. 2, Box 19, Dept. PS-3, Logan, IA 51546.

HOW-TO solar heating plans, instructions. Details. Box 1104-C Beaverton, OR 97075.

SOLAR ENERGY MANUFACTURERS DIRECTORY. COMPILED FROM REGISTRATIONS WITH FEDERAL GOVERNMENT. \$3.50 Postpaid. G.P.C., Box 652-PS, Westmont, IL 60559.

BE YOUR OWN POWER COMPANY
 Learn how to use solar, thermopile, wind, water and other electric generators with low 12 volt technology. Even powers 120V-AC appliances. Includes home emergency system plan to cope with power failures—brown-outs. Send for your fully illustrated 3 book set **THE WILDERNESS HOME POWERSYSTEM**. Enclose \$4.95 Ppd. to Jim Cullen, Dept. P, Box 732 (45501 Highway 101 N.) Laytonville, Ca. 95454 Visa/MC okay (707) 44-6186 Allow 4 wks del.

Build Your Own Windgenerator 500 and 1000 Watt
 Simple, Rugged, parts locally available, tested 3 yrs, how to find a generator, how to make a car alternator or generator produce 120 volts without taking it apart, how to make it produce at lower RPM, how to make a 12 volt motor from a car generator. \$20.
Wellington Windpower
 Wellington, Ontario. KOK 3L0

ENERGY BOOKS
AT LAST! All significant books on SOLAR energy AVAILABLE BY MAIL. Also WOOD heating, WIND & WATER power, METHANE and more. Send for 3rd edition catalog with book descriptions and conversion tables. US \$1.00 REFUNDABLE. ENERGY BOOKSTORES, Dept. PS-57, 14922 Hawk Dr., Palmdale, CA 93550.

QUIT PAYING ELECTRIC BILLS
 & save on your heating bills, too!
 New Patented Invention Now Available to Consumers in Kit Form with Easy To Follow Instructions. It's a Furnace that produces electric with no fuel cost. Automatically produces electricity proportional to heat requirements & can be used as hot water tank to provide power in summer too. Added air conditioning unit can produce substantial additional hot weather power. You can throw that electric meter away. Send \$6 for general information (refundable against purchase).
Now to: The Lavery Energy Company, 424 South Mt. Vernon Ave., Uniontown, PA 15401. We advocate a high degree of self-sufficiency. You can pay us once or the power company forever.

KALWALL'S SOLAR HEATING CATALOG
 Full line of solar heating components, including Sun-Lite® glazing and tubes. Order all materials from one source. Send \$2.00 for catalog.
Solar Components
 Dept. P, P.O. Box 237
 Manchester, NH 03105

15 HOME HEATING FUEL SAVERS
PLANS, Inexpensive Home Built Food Stove - \$4.50. F.L.W., 510 River Road, Edgewater, NJ 07020.

6 PLANS, BLUEPRINTS
CATALOG OF ELECTRONIC PLANS! PREAMPS, Speakers, Crossovers, transmitters, Linears, and more. Send \$1.00 to: Peter-Schmitt Enterprises, Dept. SP, P. O. Box 07071, Milwaukee, WI 53207.

7 BURGLAR/FIRE ALARMS
MAGNETIC LOCK-STOPS CROOKS
BOLD! No keyhole. Has magnetic key. Water, shock and dust resistant. Owner can open with ease in total darkness. Just \$7.95. Freeman Enterprises, Dept. 380-PS, P.O. Box 226, Fallston, MD 21047.

REVOLUTIONARY DOOR CHAIN!!!
DOES NOT rely on flimsy screws or frame. New, attractive design provides protection against brute strength attacks. Only \$3.95! Chain Lock, Box 44482, Dallas, TX 75234.

WARNING
 PROTECTED BY
ELECTRONIC
 AUTOMATIC
ALARM SYSTEM

How to Keep Burglars Out
BURGLAR ALARM STICKER . . . Protect against burglars, housebreakers, etc. with these stickers. Easy to apply . . . just peel off backing and stick on doors, windows, walls, etc. Each set consists of 4 front adhesive style for inside of glass doors and windows facing out, 8 back adhesive style for use on solid doors and other opaque surfaces. Color of background is green with yellow lettering. Size: 1 3/4" x 3 3/8". Made of vinyl. Burglars think you have an alarm system. 12 for \$3.00, 24 for \$5.00.
RIDGEWOOD HOUSE
 Dept. PS-3, Box 5, Ridgewood Sta. N.Y. 11227
 DEALER INQUIRIES WELCOME

21 HOBBIES / COLLECTIONS

COLLECT Military Medals. List 50c. Vernon. Box 387PS, Baldwin, NY 11510.

BUTTERFLY Clock and Picture Kits. (no paper bodies) Hardwood, all top quality. Color Brochure \$1.00. Profits in assembly and resale. Exotic Butterfly Worlds, 41900 Fremont Blvd., Fremont, CA. 94538.

SHARKS Teeth - Rare Collection (5) — \$3.00. Argonne, Box 3501, Baltimore, MD 21214.

25 FORMULAS, PLANS

20,000 MONEymaking Formulas Available - Bargains! Catalog/Manufacturing Secrets \$2.00 (Refundable): GWA6, Box 193, Brookfield, WI 53005.

NEW MONEymaking FORMULAS! CATALOG - \$1.00 - Refundable! Innovel, Box 201, Custer, WA 98240.

HENLEY'S
 20th Century Book of 10,000 Recipes, Formulas & Processes (Latest Edition)
 Here is a wealth of practical, accurate and clear information and instruction that can save you thousands, or make you a fortune! Housewives, manufacturers, farmers, handy-men, home experimenters, electricians, chemists, people in every walk of life, refer to Henley's daily. In this gold-mine of a book, you too will find formulas and recipes for almost everything used in the home, farm, workshop or industry. Discover the trade secrets of thousands of commercial products—learn new money-savings and exciting way of doing things. As indispensable as a dictionary. Satisfaction guaranteed. 900 pages hard cover-cloth binding. Only \$10.95 plus \$1.45 postage & handling.
 Dealer's Inquiries Invited
EMBASSY SALES Dept. PS-38
 Box 67, East Elmhurst, N.Y. 11369



26 SCIENCE & CHEMISTRY

EVERYTHING For Chemistry Experimenters! Catalogue \$1.00. Starr Scientific, Manitowoc, WI 54220.

NEGATIVE ION GENERATORS. (Fascinating details - \$1.00.) Golden Enterprises, Box 1282-PS, Glendale, AZ 85311.

CHEMICALS apparatus, project books, wide selection. Catalog \$1.00. Send to: Pioneer Industries, 14A Hughey Street, Nashua, NH 03060.

ECONOMICALLY Priced—Apparatus, Chemicals. Discount Catalogue-\$1.00. Hagenow Laboratories, Manitowoc, WI 54220.

GRAVIMETER - MATHEMATICAL New theory measures small accelerations due to gravity. \$30. Gravimeter, Goldthwaite, TX 76844.

NEW 200-page 1980 catalog listing thousands of chemicals, glassware and lab equipment. Send \$2.00 to: Merrell Scientific, 1665 Buffalo Road, Rochester, NY 14624.

CHEMICALS, Glassware, Kits. Catalog \$1.00. K/N Chemical Co., Box 748, San Bernardino, CA 92402.

CHEMICALS, fine labware and accessories. Wide selection. Catalog—\$1.00. Send to: Isotron Company Inc., P.O. Box 7086, Buffalo, NY 14240.

CHEMICALS, Apparatus. Lowest Prices Anywhere. Free Catalog. Avatar, P. O. Box 213, St. Charles, MO 63301.

PENNY FORMULAS, 1,000. Easily Prepared Product Formulas. Send \$10.00 to: Nile, Box 3520, Nashua, NH 03060.

AMAZING ELECTRONIC PRODUCTS
 LASERS SUPER POWERED, BURNING, CUTTING, RIFLE, PISTOL, POCKET - SEE IN DARK - SHOTGUN DIRECTIONAL MIKE - UNSCRAMBLERS - GIANT TESLA - STUNWAND - TV DISRUPTER - ENERGY PRODUCING, SURVEILLANCE, DETECTION, ELECTRIFYING, CHEMICAL, ULTRASONIC, CB, AERO, AUTO AND MECH DEVICES, HUNDREDS MORE - ALL NEW PLUS INFO UNLIMITED PARTS SERVICE.
INFORMATION unlimited.
 CATALOG \$1 Dept. PS, Box 716, Amherst, NH 03031

******LASER & SCIENCE PLANS******
FIVE LASER PLANS - \$9.
ALL ABOUT LASERS COURSE - \$10.
RUBY LASER COURSE & PLAN - \$10.
HOW TO FABRICATE LASERS - \$5.
INFRARED LASER PISTOL - \$8.
WELDING-BURNING LASER - \$9.
LASER WARS SABER/PISTOL - \$5.
"LASERAMA" LASER SHOW - \$19.
LASER AIMED 22 RIFLE - \$9.
WOOD CARVING LASER - \$10.
"WILD IDEAS" CATALOG - \$2.
SO-LASER, Laser Experts
"PS380", Box 1015
Claremont CA 91711

27 PLASTICS

MAKING Personalized Plastic Products for Fun and Profit. For information send \$2.00 to: Roy Ramos, 3982 West Vickery, Ft. Worth, TX 76107.

CASTOLITE Liquid Plastics. Crystal clear, colors. For casting, embedding, coating, fiberglassing; in industry, laboratories, craft work. Reproduce your designs with our mold materials. Profitable. Illustrated Catalog \$1.00. Castolite, Dept. 80C/PS, Box 391, Woodstock, IL 60098.

29 LOG CABIN & HOME BUILDING

EARTH SHELTERED CONSTRUCTION PLANS: Brochure illustrating available plans \$4.50. Criteria Architects, 474 Concordia Avenue, Saint Paul, MN 55103.

31 NURSERY STOCK

GROW GINSENG! \$50 pound. Have seeds, roots. Goldenseal. Information. Collins, Viola, IA 52350.

32 REAL ESTATE

42,000,000 ACRES Valuable Government land available low as \$3.50 per acre. Campsites, farms, homesites. Fabulous business opportunities. Latest report! Send \$2.00. Satisfaction Guaranteed. American Land Disposal, Box 730-B, Holland, MI 49423.

CALIFORNIA. Acreage. Lots. \$20 down. \$20 monthly. 11546 Valerio, North Hollywood 91605.

OWN CANADIAN LAND FROM \$47 ACRE— Choice properties across Canada. Low monthly payments. Cottage, hunting, fishing and investment. Twelve month exchange privilege. Six month money back guarantee. **CATALOGUE \$1.00.** Write: Canadian Estate Land, Dept. 22C, 286 Lawrence Ave. West, Toronto, Canada M5M 3A8.

FREE! Big Spring Catalog! Over 5,400 country properties described, pictured! Land, Farms, Homes, Businesses, Recreation, Retirement buys! Selected best thruout the U.S. Over 700 offices, 43 states All Across America! Yours FREE from the World's Largest! **STROUT REALTY, Inc.,** 7 S. Dearborn, Dept. 5810, Chicago, IL 60603.

ARKANSAS Ozarks - Free 1980 Real Estate Catalog. Homes, Farms, Ranches, Cheap Acreage, Lake properties, River Frontage. Baker Co., P. O. Box 10, Yellville, AR 72687.

HISTORIC Western Town, beautiful Southern Utah. Hunt, fish, camp year-round. Huge valley rimmed by mountains. Lots \$695 full price, \$10 down. Complete information \$1. Southwest, Box 37-S, Beryl, UT 84714

SELL YOUR HOME YOURSELF! Save the Commission! Complete Step by Step Kit \$39.95. Guaranteed! Details Free. **HOMESELLERS,** POB 11576-PS, Pueblo, CO 81001.

GOVERNMENT LANDS - from \$7.50 Acre! "Buyer's Guide" . . . plus nationwide listings - \$2.00. Surplus Lands, Box 19107-FC, Washington, DC 20036.

BIG . . . FREE . . . CATALOG! Over 2,700 Top Values Coast to Coast! **UNITED FARM AGENCY,** 612-PS West 47th, Kansas City, MO 64112.

FREE BROCHURE: 1500 Ozark Properties. Mild Climate. Graven Realty, 120-PS West Second, Mountain Grove, MO 65711, (417) 926-4200.

BUILDER'S SURPLUS ACREAGE, LOTS. California, Oregon, Arizona, Florida. \$125. down. Paul Lacher, 3900 Victory Blvd., Burbank, CA 91505.

10-20 ACRES in fabulous Northern IDAHO. Choice land in beautiful timbered settings. In the heart of lake, hunting & recreation country. Reasonably priced. Terms. Parcels with domestic water and power available. A unique opportunity for country living at its best. Write for free information:
NATIONAL ASSOCIATED PROPERTIES
 Dept. NC, 1121 Sherman
 Coeur d'Alene, ID 83814
 (208/664-8161)

33 SPORTING GOODS, FISHING TACKLE, ETC.

WARM-UP Suits. Triple Knit. At Factory Prices. Catalog \$1.00 (refundable). Warm-Up, 317 Nandina Street, Philadelphia, PA 19116.

NEVER BUY BATTERIES AGAIN!

Generator flashlight, just squeeze the handle! Always ready. Perfect for home, car, camping, boating. Shockproof & water-repellent case
 only \$4.98
MONEYBACK GUARANTEE (plus 75¢ shipping)
EASTMAN BELL, Dept. 3-P.S.
 7324 Claredon Dr., Edina, Mn. 55435



34 CAMPING EQUIPMENT & TENTS

FREE Catalog. Everything for Camping. Campmor, Box 407P, Bogota, NJ 07603.

WILDERNESS SURVIVAL Pocket Manual. Over 300 Techniques; Worldwide. Ten 3"x5" plastic pages. \$3. S-Cards, Box 1805, Bloomington, IN 47402.

35 AQUARIUM SUPPLIES

LIVE SEA HORSES \$398
 Kit includes 4 adults & up to 30 ponies from pregnant male, marine salt, food, live plant, live snail & instructions. Above kit with Custom Aquarium, sea horse tree, seashells, coral, silica sand + 2 ghost shrimp \$7.95. **Large Deluxe Aquarium** with all custom kit accessories & 10 adult sea horses (2 preg. males - up to 60 sea horses) \$12.95. *Kits sent ppd. Live delivery guaranteed. via air mail.*
Sea Horses Inc., Dept. PS 30, Box 1477, Coral Gables, FL 33134



39 EARTHWORMS, CRICKETS, FROGS

FREE Literature—We Teach You To Raise, Sell Fishworms, Crickets, 12-inch African Worms, Carter Farm-12, Plains, GA 31780.

40 HUNTING & FISHING INFORMATION

QUAIL And Equipment Catalog. Also Booklet "How To Produce And Sell Quail Year Around." Send 25c to: GQF Mfg., P. O. Box 1552-K, Savannah, GA 31402.

42 FIELD GLASSES, TELESCOPES

FREE Catalogue! Thousands War surplus optical bargains. Lenses, Prisms, Telescopes, Binoculars, etc. Jaegers, 691G Merrick Road, Lynbrook, NY 11563.

43 GOV'T. SURPLUS

DISCOUNT Catalog. Viet-nam Boots, Canteens, Viet-nam Jackets, Knives, Jungle Hats, Packs, Helmets, C-rations. Send \$1.00 refundable. Dixie Military Surplus, Box 8149-PS, Nashville, TN 37207.

JEEPS \$52.40, Airplanes \$75.01, typewriters \$6.70. Boats \$7.50, direct from Government Directory and Surplus Catalog \$1.00. (Refundable). Midwest Surplus, Box 401-PS, Dayton, OH 45401.

JEeps, Trucks, From \$52.40. Boats, Airplanes, Automobiles, Motorcycles, Typewriters, Tools, Clothing, Sports, Camping, Photographic, Electronic Equipment. . . 300,000 Amazing Bargains Direct From Government Nationwide. . . Low as 2c on Dollar! Surplus Catalog and Sales Directory \$2.00 (Refundable). Surplus, Box 954-PPS, Muskegon, MI 49443.

GOVERNMENT Surplus. Buy your Area, How, Where, Send \$2.00. **SURPLUS, 615-PS HEADQUARTERS BUILDING,** Washington, DC 20036.

JEeps - \$19.30! CARS - \$13.50! 650,000 ITEMS! **GOVERNMENT SURPLUS. MOST COMPREHENSIVE DIRECTORY AVAILABLE TELLS HOW, WHERE TO BUY - YOUR AREA - \$2 - MONEY BACK GUARANTEE.** "GOVERNMENT INFORMATION SERVICES," DEPARTMENT A-3, BOX 99249, SAN FRANCISCO, CA 94109.

FREE! Directory Information Importers' Listings, Samples — enclose stamped commercial self-addressed envelope. Lenner's - 337E, Brooklyn, New York 11224.

JEeps - \$18.88. 675,000 Items! Buy In Your Area! How! Where! "Moneyback GUARANTEED" 1980 Government **SURPLUS** Directory" including: "Buy G-LANDS" - "G-Oil/G-Gas LOTTERIES," \$2.00. **GSURPLUS, Box 2009-C, Syracuse, NY 13220.**

1980 SURPLUS Army, Navy store 64 page illustrated catalog. Send \$1.00. Ruvel, 3037 North Clark, Dept. M3, Chicago, IL 60657.

OFFICIAL USA DIRECTORY! Jeeps \$37.22! 400,000 Listings! Your Immediate Area! **UNEQUALLED! \$2.00 (INCLUDES G-LANDS, G-LOTTERIES, INFOGUIDES!)** US/Great Lakes Federal Depository, B-807SJ, Marshfield, WI 54449. (COPYRIGHT 1980)

"GOVERNMENT SURPLUS Directory." Buy 250,000 items (including jeeps) . . . low as 2c on dollar! Most complete information available - \$2.00. **SURPLUS DISPOSAL,** 19107-FC, WASHINGTON, DC 20036.

46 PROFITABLE OCCUPATIONS

FREE Catalog. Repair Air Conditioning, refrigeration. Tools, supplies, full instructions. Doolin, 2016 Canton, Dallas, TX 75201.

SURPRISE Everybody. Become Notary Public now. We guide you, free. We sell notary needs. Raise your image, job value, income. Assistance nationwide. Brochure: Gulf, 234 Club-B, San Antonio, TX 78201.

STUDIO Home Knitting Machines are a profitable hobby. Credit available. Send \$1 for information to: Studio, Box PS-46017, Seattle, WA 98146.

MECHANICALLY INCLINED INDIVIDUALS

Assemble electronic devices in your home. Knowledge or experience not necessary. Get started in spare time. Above average profits. \$300-\$600/wk. possible. Sales handled by others. No investment - Write for free details.

ELECTRONIC DEVELOPMENT LAB
Box 1560G, Pinellas Park, FL 33565

47 BOOKS & MAGAZINES

PUBLISHERS' OVERSTOCKS, BARGAIN BOOKS, 3,000 titles, all subjects! Free Catalog: Hamilton, 98-72 Clapboard, Danbury, CT 06810.

GOOD News Bibles — Today's Version. Information — \$2.00. Bridges, Box 4413-P, Hollywood, FL 33023.

READY REFERENCE
SAVE your copies of Popular Science neatly with handsome, rugged file cases and binders. Dark blue with Popular Science logo, holds a year's issues. **FILE CASES:** \$4.95 each, 3 for \$14 or 6 for \$24. **BINDERS:** \$6.50 each or 4 for \$25. Send check or money order to Jesse Jones Box Corp., P. O. Box 5120, Philadelphia, PA 19141.

BE A HAPPY TAXPAYER!
GET Your Share of 100 Honest Tax Savings and 8 1979 tax credits. All explained in 110 Plain English pages. Start saving today. Guaranteed. \$2.95. Plain Talk Press, Box 16023-SB, Irvine, CA 92714.

JOGGER'S Journal: Record Book for the Jogger - \$5.00. Leduc, 104 A South, Cowansville, Que. J2K 2X2.

HELPFUL books on **CLOCK AND WATCH REPAIR.** Free catalog. North American, Box 77-BPA, Fox River Grove, IL 60021.

49 JOKES & NOVELTIES

FREE World's Leading Novelty Catalog. 1600 Jokes, Tricks, Science, Sports, Hobbies. Johnson-Smith, C-11, Mt. Clemens, MI 48043.

BRAND NEW FUN CATALOG. HUNDREDS OF SUPER GIFTS, GIMMICKS, AND NOVELTIES. SEND 25c TO FUN FACTORY, INC., DEPT. 1192, 41 SMITH STREET, ENGLEWOOD, NJ 07631.

50 MAGIC TRICKS, PUZZLES, ETC.

FREE! \$2.00 trick, huge catalog, all 50c. Abracadabra-SP, Scotch Plains, NJ 07076.

MYSTERIOUS HEROS FOUNTAIN QUALITY Acrylic made 3 1/2" diameter x 9". No moving parts. Fascinating — Educational — Conversation Piece. \$25.00. **DECA ENTERPRISES,** 8060 Granville Avenue, Richmond, B.C., Canada V6Y 1P4.

51 COINS & CURRENCY

HONG KONG DOLLAR Only 10c. Uncirculated cupronickel dollar. Limit One. (Adults Only.) Plus price lists. Littleton Coins, KH-2, Littleton, NH 03561.

3 OLD Liberty Head Nickels Only \$1.00. Issued before 1913. Limit 1 Set. (Adults Only.) Plus price lists. Littleton Coins, HL-2, Littleton, NH 03561.

INEXPENSIVE Quality Foreign Coins. Write: Paul C. Welz, 421 Balboa Street, Dept. PS, San Francisco CA 94118.

UNBELIEVABLE, 100 UNCIRCULATED coins from 100 COUNTRIES only \$12.99. Entreprises, Box 275, Coteau Landing, Quebec, Canada, J0P 1C0.

LINCOLNS: 10 different 1910-40 \$1.00. Nayko, 214F, Kennedy Airport, N.Y. 11430.

INDIANHEAD & Lincoln Cents, 1890's - 1949, Different - \$2.99. Coin Catalog - 25c. Edel's, Carlyle, IL 62231.

52 STAMP COLLECTING

UNITED NATIONS 3 Complete Mint Sets 25c. Approvals. Cornetta, POB 1509-P, Lake Placid, FL 33852.

500 DIFFERENT Stamps for \$2.00. Smith, 508B Brooks, College Station, TX 77840.

PENNY Approvals! Regardless Catalogue! Kloster, 4164—52nd Street, San Diego, CA 92105.

U.S. 100 DIFFERENT 10c approvals. Stamps, Box 385-S, Midlothian, VA 23113.

50 DIFFERENT Old U.S. between 1861 and 1939 \$1.00. Ed Roush, 423 Shepard, Mansfield, OH 44907.

FREE Surprise collection sent with approvals. Jay, 1784 Union, San Francisco 94123.

FIFTY Free Stamps With Approvals. J&D Stamps, Box 747, Melbourne Beach, FL 32951.

PENNY Approvals. Regardless Catalogue. Zamora, 1 Mendez Liciaga, San Sebastian, Puerto Rico 00755.

FREE, U.S. Mint Set. Approvals. Hildebrand, Box 4867, Santa Clara, CA 95054.

FREE Worldwide packet. Penny approvals. Froelich, Box 412-B, Morton Grove, IL 60053.

50 YEARS Old, fifteen different United States, over fifty years old 25c with approvals. Jaxon, Box C11, New Rochelle, NY 10804.

OLD U.S. Stamps on approval. Chester. Box 15414-R, Philadelphia, PA 19149.

1000 DIFFERENT Stamps - \$3.90; 3000 - \$16.70. Free Packets Catalog. Ullery, 1016 Meridian, Mishawaka, IN 46544.

"INVERTED ERROR" + 100 Different United States. 35c with approvals. Belmont Stamps, Washington, DC 20015.

FREE! Big Bargain Catalog — New Edition listing thousands of bargains including U.S. & B.N.A. stamps, packets, albums, accessories and supplies. Also, fine stamps from our approval service, buy any or none, return promptly, please. Jamestown Stamp, Dept. E30PS, Jamestown, NY 14701.

FREE! 55 Different, Including Triangles. Space, Others! Request approvals. Baird, PS 56, Box 8128, Portland, OR 97207.

55 DIFFERENT U.S. Stamps! Only 10c. Includes Old Issues, Commemoratives, High Values, Airmails, plus hard to get \$1.00 stamps. (Adults Only.) Goliath, W-2, Bethlehem, NH 03574.

GRAB BAG of over 100 Unsorted Stamps, only 10c. Contains New Issues, Asia, South Seas, Africa, etc. (Adults Only). Littleton Stamps, EX-2, Littleton, NH 03561.

MAKE money collecting, trading and selling stamps. Learn why price of stamps will skyrocket soon. Report \$3.00. World Mail Order Products Co., P.O. Box 910, Bronx, NY 10451.

SPECIAL - 400 U.S. 30c. Approvals. Wright, Box 753-P, Hagerstown, MD 21740.

FREE! "MONEY SAVING" U.S. Price List. Scotco, X4455-PS3, Hollywood, FL 33023.

FREE U.S. \$1.00 Stamp. Older Issues, Commemoratives, Airmail, Virgin Islands, Others - Catalog Value over \$5.00. U.S. Bargain Price List. All Free! Send 10c for Mailing. Empire Stamp, Toronto, Ontario, Canada M4W 2M2.

SEND only 10c for nice collection of U.S. Stamps including \$5.00 issue and scarce mint Sixpex Souvenir Sheet. Attractive price lists of other beautiful stamps and collectors supplies included. Mystic Stamps, SS-2, Camden, NY 13316.

1000 FOREIGN \$2.00; 5000 \$6.00; 9000 \$9.00. 10 pounds on paper \$35.00. 5000 USA (contains regulars, commemoratives, high values, older stamps, etc.) \$5.00. 700 pre-1939 USA \$4.00; 2200 \$12.00. Delivered. Meyers, 5321 Fleming, Richmond, CA 94804.

54 RADIO, TELEVISION

36c TUBES. Radio & TV! Free Color Catalog. Cornell, 4217S University, San Diego, CA 92105.

POLICE Scanners, Crystals, Radar Detectors. HPR, Box 19224, Denver, CO 80219.

FREE Educational Electronics Catalog. Edukits Workshop, Department 798-A, Hewlett, NY 11557.

BUILD YOUR OWN TV CAMERA!
"Ideal for home & business"

Whether for FUN or PROFIT, we challenge you to the exciting field of TV recasting. Complete kit only \$185.00. Solid-state. Also available assembled. Connects to any TV set. Reviewed in this magazine, August, '73 issue

PHONE OR WRITE FOR FREE ILLUSTRATED CATALOG OF KITS... DIAL 402-987-3771 (today)

ATV Research
1305 BROADWAY ST. N., DAKOTA CITY, NEBR. 68731



54A CB RADIO

CB TUNEUP/MODIFICATION REPAIRS. \$3 each, specify model. Free catalog. CB City, Box 1030P, Woodland Hills, CA 91365.

INCREASE CB RANGE— Legally! Free Information. "SKIPPER", Box 130-C3, Paradise, CA 95969.

55 ELECTRONICS, STEREO, HI-FI

COMPUTERS: Wholesale, Catalog-Buyer's Guide \$1.00; Lee, Caneyville, KY. 42721.

56 RECORDS, TAPES, etc.

OLD Radio Programs on Cassette Tapes. Send 15c Stamp for Catalog. Box 16365-P, St. Louis, MO 63125.

OLDIES — 45 RPH Original hits. Catalog \$1.00. C&S Record Sales, Box 197, Wampsville, NY 13163.

RECORDS - TAPES! Discounts to 73%; all labels; no purchase obligations; newsletter; discount dividend certificates; 100% guarantees. Free details. Discount Music Club, 650 Main Street, Dept. 4-0380, New Rochelle, NY 10801.

57 MUSICAL INSTRUMENTS

INTERNATIONAL Catalog valuable to makers, repairers of stringed instruments. Imported woods, parts, accessories, kits. Fine German-made violins, violas, cellos, basses and bows. Send 25c for catalog. Credit certificate worth \$1.25 enclosed with catalog. International Violin Company, Dept. AG, 4026 W. Belvedere Ave., Baltimore, MD 21215.

SAVE ON ACCORDIONS



40 Models! Famous Makes! SAVE! Direct from Importer. Models for students, teachers, professionals. Standard or Electronic. Terms. Trades welcome. Home Trial. Hohner Button models too. FREE catalog and importer prices.

ACCORDION CORPORATION
5535 (PX) Belmont Avenue, Chicago, Ill. 60641

58 SONG WRITERS

POEMS set to music, Nashville Music Productions, Box 40001-PS, Nashville, TN 37204.

59 IMPORT-EXPORT

2500 "FAST Selling" Products. Free Brochures! Balco, Box 91309-X3, Cleveland, OH 44101.

60 BUSINESS OPPORTUNITIES

NEW TAX LOOPHOLES Discovered. Everyone eligible. Free facts. ULC, P. O. Box 359-00, Clarkston, GA 30021.

REPAIR HYDRAULIC JACKS—Free details. Hydraulic Parts Supply, Dept. S, Box 4157, Brownsville, TX 78520.

MAKE More Money by mail. HACO, Box 846, Nashua, NH 03061.

SYNTHETIC OIL DEALERS Needed. Exciting Products & Opportunities. Make More Spare Time Than in Present Business or Job. Collect (316) 686-0441.

\$58.90 DAILY PAY. \$353.88 WEEKLY. Homework. Immediate Income. Earnings guarantee certificate. Free report/Application. AAHIP, Unit 29309-A, Medcensta, TX 78229.

300% Profit Possible Selling Gift Items, Novelties, Toys!! Minimum Investment! Full Profit Details. Hughes Giftworld, Box 9016PS, Newark, NJ 07104.

FREE Inflation-Beater Book "2042 Unique, Proven Enterprises." Fabulous "Little Knowns." Work Home! Haylings-E, Carlsbad, CA 92008.

\$92.00 FROM Square Foot Plywood (Huge Demand). Revealing Proof 25c (Refundable). Woodwins, Bridgewater MA 02324.

VINYL'S Where the money is! Professionally repair, refinish, recolor furniture, luggage, car tops. Quick, easy. Two small \$20 jobs a day earn you \$1,000 a month. Homes, cars, offices, restaurants, unlimited customers. Start earning after a few days practice. Sensational details Free, VIP, 2036 Montrose, Chicago 60618.

ABANDONED INDUSTRIAL SILVER —take it! Details: Silver, Box 548, Woodville, TX 75979.

VENDING Machine. No selling. Routes earn amazing profits. Big Catalogue Free. Parkway Corporation, 1930PSE Greenspring Drive, Timonium, Maryland 21093.

PIANO Tuning leaned quickly at home! Free information. Empire School, Box 450327, Miami 33145.

MECHANICALLY inclined individuals desiring High Weekly Profits operating Small Manufacturing business Without Investment write: Businesses, 92-P Brighton 11th, Brooklyn, NY 11235.

MAKE \$2,000.00 Monthly Spare Time. Unique proven enterprise. No selling. No capital to start. Free brochure. Kashbuilder, Box 1132-PK, Indianapolis, IN 46225.

PLASTERCRAFT — Profitable Home Business. Over 1,000 molds available. Details: Lynnette, 6251R Mentor Park, Mentor, OH 44060.

LEARN Sewing Machine Repairing. Men, Women, Lucrative profits. Gresslin Correspondence School, Box 927, Spencer, IA 51301.

FREE Mailorder Dropship Business Journal! Mailer's World, Box 1355-P, Sioux Falls, SD 57101.

GET RICH! Secret law smashes debts—Brings cash and credit. Details free! Wealthkit, Box 350-S, Billings, NY 12510.

PIANO Tuning quickly learned with home study course. Diploma granted. American Tuning School, 17050 Telfer Drive, Morgan Hill, CA 95037.

BEAT the Races! Free Booklet! "Unlimited Lifetime Income from Thoroughbreds - Harness". Elias, Box 47-G, Brooklyn, NY 11219.

I MADE \$40,000.00 Year by Mail-order! Helped others make money! Details 25c. Torrey, Box 318FF, Ypsilanti, MI 48197.

PHOTOSTAMP Agents Wanted! Make Big Money from Home Mailorder. Free Samples & Information: Postermatic-C8, East Providence, RI 02914.

NEW Luxury Car Without Cost! Free Details. Codex-B, Box 6073, Toledo, OH 43614. (419) 865-5657.

MILLIONS in Mail! Free Secrets. Transworld-11, Box 6226, Toledo, OH 43614.

MANUFACTURER NEEDS MAN To Assemble Product at home and supply national sales crews, full or part time. Should desire business of their own. Five-figure income potential. S.K.R.C. Manufacturers, River Bend Plantation, Broadway, NC 27505.

BELTS And Buckles. Complete Line Fast Sellers, including Westerns, Truckers, Motorcycles, Wildlife, etc. Big Profits. Complete dealer set up. Free Catalog. Anchor, Box 3958-BPS, North Providence, RI 02911.

\$500 - \$1000 MONTH Plan raising rabbits for us. Free details. White's Rabbitry, PS, Hudson, OH 44236.

SELLING KNAPP SHOES IS EASY. Highest cash commissions immediately. Enjoy a steady income with satisfied repeat customers. Your own hours. No investment. Free sales kit. Knapp Shoes, K-611 Knapp Centre, Brockton, MA 02401.

MAILORDER \$1,000.00 Possible Monthly Selling Information. Free Details: AR Enterprises, Box 92-S, Bronx, NY 10465.

EASY CASH! Sell opportunity books! Free distributorship! Allen, 5711-J Graves, Encino, CA 91316.

\$534.00 WEEKLY working three hours daily at home. \$356.00 weekly working two hours daily. \$178.00 weekly working one hour. Start immediately. Paid daily (advance) - \$106.80, \$71.20, or \$35.60. Written Earnings Guarantee. Free Bulletin/Application. FAS, Postal Unit 13703-B, San Antonio, TX 78213.

\$50,000/ YEAR distributing bacteriostatic water purifiers. (Details - \$1.00.) SAFEWATER, Box 39195, Phoenix, AZ 85069.

2,000% PROFIT. Free detail send stamp. Geter Assoc., P.O. Box 837, Milwaukee, WI 53201.

\$100's INCREASED profits repairing electric hand tools. Details \$2.00. ALLTOOL, POB 208C, Scottsbluff, NE 69361.

MAILORDER Opportunity. Start profitable home business without experience or capital. Write for free book, plus details. Mail Order Associates, Dept. 546, Montvale, NJ 07645.

MAILORDER FORTUNE! Beginners helped mail our **BOOMERANGS** from home. Box 33, Coramba 2466 Australia.

SAVE GASOLINE!! Professional reveals retuning secrets. Details — Posco, GS3, Box 300, LaGrangeville, NY 12540.

\$1200.00 MONTHLY CORRECTING STUDENTS' LESSONS at home! Start immediately. No experience needed. Free report. Send self-addressed stamped envelope. Alpha, Box 131-YBCV, Van Nuys, CA 91401.

\$2100 WEEKLY Possible in mail order! Free report. Trade Winds-42, 31 Tracy Rd., New Paltz, NY 12561.

LOTTERIES Agents Worldwide Wanted. Box 35699, Vancouver, B.C., Canada V6M 4G9.

FREE DETAILS ON HIGH PROFIT MAIL ORDER Book Business. Vantage, Box 224-PS, Hyde Park, MA 02136.

OUTSTANDING High Income Opportunity! Home Services - Insurance Restoration Business. Free Details. HSIR Program, 216 Hayes, Chapel Hill, NC 27514.

MAKE \$15.00 hourly building custom luggage/cases at home. Huge nationwide demand. Fill mail orders. We supply materials, instructions... everything. Free details. Customcase, 6075 De Soto Ave., Dept. X28-87, Woodland Hills, CA 91365.

EARN BIG FEES - Fascinating Opportunity. Become Money Broker. Own hours. No experience. Proven success formula. Free Report: DFC, Dept 11-P-3, 1145 Reservoir Avenue, Cranston, RI 02920.

JEWELRY SALES CAN MAKE YOU RICH! Full or Spare Time. Starter kit \$1.00 (Refundable). Nasco, 310-BPB Lincoln Avenue, Fox River Grove, IL 60021.

SELL SENSATIONAL LOW-COST BURGLAR ALARM. Lightning seller. Exceptional margin. Samples for trial. Northwest Electric, Ave. 2126, Mitchell, SD 57301.

TAKE Catalog Orders. We dropship 2500 Best-selling specialty products. Lowest below-wholesale prices. Immediate delivery. Spectacular home business opportunity. Free Book. SMC, 6061 De Soto Ave., Dept. 28-87, Woodland Hills, CA 91365.

IMPORT-EXPORT opportunity, profitable world-wide, mail order business from home, without capital. We ship plan for no risk examination. Experience unnecessary. Free Report. Mellinger Dept. C2693, Woodland Hills, CA 91367.

WE Pay \$1 Each Photo Done! \$12.50/Hour, Easy! Write: Free Report, #PS-3, 3110 Fulton, Sacramento, CA 95821.

"ADS 'N' ANSWERS" has current Business & Money-making Opportunities classified answers. We answered 'em all for you. Send long, self addressed, stamped envelope: Consumer Assistance Corp., Dept. A-C, Box 13102, St. Petersburg, FL 33733.

\$30,000 MONTHLY, oil lease firm, legal lottery operated by mail. Details \$3. JT, Box 7798, Waco, TX 76710.

OIL - How To Get In The Oil Business Treatise \$5.00. OIL, Box 2441, Monroe, LA 71207.

BIG Profits In becoming a supplier to major industry through electroplating small parts and metalizing non-metals. Write for free particulars: Mason, Room MC-3-JC, 1512 Jarvis, Chicago, IL 60626.

MAKE \$100 DAILY! Fantastic home business taking catalog orders. 2500 Products! **FREE CATALOG-BUSINESS PLAN OFFER, RICHWAY,** Box 1729-PS, Sonora, CA 95370.

be a TAX CONSULTANT

Income unlimited in full or part time home business preparing tax returns in busy tax season, plus year-round monthly fees to \$50 from business tax service. No bookkeeping experience needed. We train you at home, help you start. Accredited Member NHSC. Free literature. No salesman will call. Vet Approved. National Tax Training School, Monsey, 1CM, N.Y. 10952

BUMPER STICKER PRINTING DEVICE

Simple, Cheap, Portable. Any Message in Minutes. Send for **FREE DETAILS.** **BUMPER-PRESS** P.O. Box 22791 (LL) Tampa, Fla. 33622

BIG PROFITS **ELECTRONIC ASSEMBLY BUSINESS**

Start home, spare time. Investment, knowledge or experience unnecessary. BIG DEMAND assembling electronic devices. Sales handled by professionals. Unusual business opportunity.

FREE: Complete illustrated literature
BARTA, Box 248-SC
Walnut Creek, Calif. 94597

61 MONEYMAKING OPPORTUNITIES

NOVELTY IMPORTS Sell Like Mad! Make Huge Profits. Nine samples and large wholesale catalog - \$1.00. Lakepoint Imports, 6646 North Western, Chicago, IL 60645.

LEARN The Secrets of Repairing Junk Batteries. "Fabulous Profits", small investment. Apex Engineering, 5454 Bolsa Road, Atascadero, CA 93422.

BIG MONEY! Interested? Free Disclosure. Febre-M, Box 6073, Toledo, OH 43614. (419) 865-5657.

MAILORDER SUCCESS! Interested? Free Expose. TWP-M, Box 6226, Toledo, OH 43614.

GOLD from rivers and streams. Details 25c. Seekay Chemical, 210 Fifth Ave., New York, NY 10010.

NEW Discovery in Battery Reconditioning Means "Big Profits Fast." Electroan, 7415 Gable Drive, Little Rock, AR 72205.

\$65,000 OPPORTUNITY. Free information send stamp. Geter Assoc., P. O. Box 837, Milwaukee, WI 53201.

\$48.65 DAILY Starting next week. No mailorder swindle or stuffing envelopes ripoff! For information mail 15c poststamp: Sbiapox, Drawer 4099, Valley Village, CA 91607.

OVER 800 Flea Market Ideas - \$1.00. Splatter, Box 4, Harper, WV 25851.

HOW To Close More First Call Sales. Easy to follow report on the successful VPS Technique. Send \$2.00 to: Neville Associates, P. O. Box 146, Woodmere, NY 11598.

STOP Wasting Money answering questionable opportunity ads. 1000 offers explained. Globe, Box 20588-PS, St. Louis, MO. 63139.

ERASE DEBTS with little-known law: **CREATE** wealth! **FREE** report. Blueprints, S3, Box 100, La Grangeville, NY 12540.

NATIONAL COMPANIES seek men and women to work spare time from home. No investment. Great 2nd income opportunities. Examine hundreds of offers in 5 free issues of Opportunity Magazine. Write: Opportunity, Dept. 474, 6 N. Michigan, Chicago 60602.

HUGE PROFITS From Silver Dollars. Booklet Tells All. \$1.00. Mark Schwartz, Box 162, Cambridge, MA 02142.

LET Me show you how you can have your own Rubber Stamp Business Free! Write: Roberts, Room RC-3-JC, 1512 Jarvis, Chicago, IL 60626.

MAKE TOP MONEY IN STAINED GLASS

Learn at home in your spare time. Program includes your book of completely illustrated lessons — all professional tools, many interesting projects and more. All this is included in our self-study program. Everything needed to start you on your way to success. — **FREE INFO** REGINA CAREERS LTD.—Pub. Dept. PSG-30 33 E. Main St., Round Lake Park, IL 60073

FIRE YOUR BOSS

World-renowned PhD scientist/business analyst is teaching radically effective approach to genuine financial independence. His new discovery is drawing international attention because anyone begins easily part-time w/o capital or education. Free proof.

ACHIEVEMENT
2500 Louisiana NE, Suite 513-SF
Albuq., NM 87110

WOODCARVING BY MACHINE

Earn up to \$28.00 an hour. Trace plaques, statues, gunstocks, decoys, furniture, nameplates, etc. Minimal skill needed. Unique patented Kurt carving equipment lets you turn spare time into an enjoyable hobby and potential profit. No big investment or franchise fee. A proven moneymaker. Send 50¢ for 20 page Brochure.

KURT MANUFACTURING COMPANY,
1720-P Marshall St. N.E., Minneapolis, MN 55413.

62 EMPLOYMENT INFORMATION

LAS VEGAS - Hundreds of jobs - Current list, including salaries - \$2.00. BW Enterprises, Box 18414-132PS, Las Vegas, NV 89114.

OVERSEAS oilfield jobs. 200 companies. List \$4. Oilfield Consultants, PS-30, 123 Carlin, Lafayette, LA 70501.

TRUTH FROM AUSTRALIA—JOBS, Incomes, Tourism—Latest Facts Book. \$4.00 bills to: Infoton, POBOX E-91, Forestville 2087, Australia.

OVERSEAS . . . \$15,000-\$50,000+. Free Information! Employment, Box 29217-FC, Indianapolis, IN 46229.

AUSTRALIA — New Zealand! Big pay! 75,000 jobs. Free transportation. Employer listings \$2.00. Plus information 68 countries. Austco, Box 4116-F, Hayward, CA 94540.

**JOBS OVERSEAS
JOBS OVERSEAS
JOBS OVERSEAS**
(Including Alaska) Free Details,
Wages, Countries, How To Apply.
Global Employment
Box 808-PS
National City, California 92050

62A HELP WANTED

PARTTIME piece work. Webster, America's foremost dictionary company needs home workers to update local mailing lists. All ages, experience unnecessary. Send name, address, phone number to Webster, 175 Fifth Ave., Suite 1101-CN-6, New York, NY 10010.

TEXAS REFINERY CORP. offers plenty of **MONEY** plus cash bonuses, fringe benefits to mature individual in your area. Regardless of experience, write: W. E. Pate, Pres., Texas Refinery Corp., Box 711, Fort Worth, TX 76101

63 SPECIAL SERVICES

INFORMATION On Anything. Ferguson Research Specialists, 60-15 Woodside Avenue, Woodside, NY 11377.

INFORMATION on anything. Thorough, reasonable, fast! P1 - Global Research Associates, Box 182, Yalesville, CT 06492.

RESEARCH/Assistance, any subject. Mailway Research, Box 24949E3, Nashville, TN 37202.

INFORMATION On Anything Through U.S. Patents. Copies \$2. Send Patent Number to: Patents, P. O. Box 2624, Arlington, VA 22202.

66 AGENTS WANTED

EARN Extra Spending Money! Write orders for your friends and family and earn \$250/Month or more. Sell quality Mason Shoes. Absolutely no investment. Write: Mason Shoes, K-526, Chippewa Falls, WI 54729.

FREE SHOES!
RETAIL VALUE OVER \$30

I'll show you how you can earn free shoes or boots for yourself PLUS up to \$200 a month in extra income. Show friends and neighbors how they can save \$15 to \$20 a pair on high quality shoes or boots. Selling kit free. Write: Gordon King, Hanover Shoe, Inc. Dept. 2605, Hanover, Pa. 17331

67 SALESPERSONS—DISTRIBUTORS WANTED

EARN BIG COMMISSIONS

WORK FULL OR PART TIME! Show big FREE SALES KIT featuring complete line low priced business printing and ad specialties to business people. Build profitable repeat business. Start now.

NATIONAL PRESS, INC.
DEPT. 027
NORTH CHICAGO, IL 60064

68 REMAILING SERVICES

MANHATTAN: Mailing Address: Confidential, Reasonable. Monthly Rates. Mail handled as requested. Call Director, 701 7th Ave., NYC 10036.

70 AUTHOR'S SERVICE

PUBLISH YOUR BOOK! Join our successful authors. Publicity, advertising, beautiful books. All subjects invited. Send for fact-filled booklet and free manuscript report. Carlton Press, Dept. PSC, 84 Fifth Avenue, New York 10011.

72 EDUCATION & INSTRUCTION

EARN Extension Degrees in Homeopathy, Radionics, Botanic Medicine, Naturopathy, Philosophy, Psychology, etc. School Founded 1961. Prospectus \$1.00. Airmailed. Secretary PA/PS, Brantridge Forest School, Highfield, Danehill, Sussex, England RH17 7EX.

DEGREES, Thesis Method. Brochure, \$1. North, Box 3388, Tulsa, OK 74101.

FREE Lifetime Ordination. Become Chaplain, Missionary Evangelist, Bishop. Box 744-PS, McKeesport, PA 15134.

LEARN GAS TURBINES! Correspondence course covering all systems, maintenance, theory, operation. Established 1957. Valuable diploma awarded! **AMERICAN JET SCHOOL,** Department PS-1, Darby, MT 59829.

LEARN Dowsing, Radionics, Radiesthesia and E.S.P. Subjects. Free Illustrated Catalog. Courses and Equipment. (Airmailed \$2.00.) Established 30 Years: Bruce Copen, Highfield, Danehill, Sussex, England RH17 7EX.

BARTENDING — Bar Management Home Study. Bartending Training, 3843-G San Fernando Road, Glendale, CA 91204.

ELECTRONICS Degree (BSET) by correspondence. Grantham College, 2500 La Cienega, Los Angeles, CA 90034.

LEARN WHILE ASLEEP! Astonishing New Method! Strange Catalog Free! Autosuggestion, Box 24-A, Olympia, WA 98507.

COLLEGE Students! Improve your grades. Send \$1.00 for 356-page, collegiate research papers catalog. 10,250 available. Research Assistance, Box 25918-Q, Los Angeles, CA 90025. (213) 477-8226.

WELDING TRAINING. Basic and Advanced for Major Processes — Arc (Stick), MIG, TIG, Gas, Pipe all processes. A non-profit school. Accredited member NATTS. Approved Ohio 70-12-0064 HT. Write for school bulletin and course schedule. **NOBART SCHOOL OF WELDING TECHNOLOGY,** Box 80, Troy, OH 45373.

MEMORY, Sleep Learning. Free Publication. DLP, Box 487, Anaheim, CA 92805.

FCC LICENSE, 1st & 2nd Class, Electronics Career courses by mail. G.I. Bill. **FREE** School Catalog and Information. School rep will try to call. Write Cleveland Institute of Electronics, Inc. (CIE), Dept. WPS-57, 1776 East 17th Street, Cleveland, OH 44114.

BRITISH DEGREES, Diplomas, Doctorates. Obtain yours now from London, England. Commerce Philosophy Sciences, Divinity, Medicine. Over 40 subjects. Free prospectus (Airmail \$1.00 Refundable). College Registrar, Dept. 1029, BCM-Collegiate, London WC1V 6XX, England.

UNIVERSITY DEGREES! No Classes, Fast, Economical. Accredited. **FREE** Revealing Details. Success, Box 13151-S3, Columbus, OH 43213.

UNIVERSITY DEGREES BY MAIL! Bachelors, Masters, PH.D.s... Free revealing details. Counseling, Box 389-PS3, Tustin, CA 92680.

EARN HIGH SCHOOL DIPLOMA AT HOME FAST! State Registered. Lowest tuition available. Individual counseling. Credits awarded for job experience and previous courses. Free school ring. Call free: 1-800-327-8103. Cambridge Academy (PS-3), 409 E. Osceola, Stuart, FL 33494.

FORGET FORGETTING!

People world-wide have authentic photographic recall & literally RE-EXPERIENCE childhood scenes (documented) using newest memory discoveries of long-famous (TIME, NEWSWEEK, etc.) professor. PhD test ratings (Stanford, Yale, Georgetown-trained scientist, book reviewer): "far surpasses other methods" "memory gains 200%+ in 2 weeks." For free facts (before you forget):

ACHIEVEMENT, Suite 513S, 2500 Louisiana N.E. Albuquerque, NM 87110

INSTANT MEMORY
The new way to remember
A short, simple method of acquiring a powerful memory. No memorization, no keywords. Release your photographic memory. Learn "how" you remember, "why" you forget. Discover your natural ability to recall everything. Send for free information to:
INSTITUTE OF ADVANCED THINKING
859PS ViaLaPaz, Pacific Palisades, CA 90272

STUTTER?

BREAK THAT HABIT NOW! Learn Fluent, Normal speech. Easy self-study corrects stammer or stutter habit. Amazing results by correspondence since 1935! Speech Pathologists certified by Florida Commissioner of Education. Money refundable if not helped. Free details. Write today: Emory Institute, Box 967-PS, Winter Park, Fla. 32790.

73 CARTOONING, SIGN PAINTING

CARTOON for money!!! Free Book: Success, Box 885B, Dearborn, MI 48121.

LEARN Cartooning. Fun or profit. Cartooning, Box 7069A, Colorado Springs, CO 80933.

LEARN Sign Painting—Free Catalogue. Kaufmann Supply, Centertown, MO 65023.

MODERN Cartooning Taught by Mail. Write for Free Brochure. Cartoonrama, Box 263-AJ, Branford, CT 06405.

76 DETECTIVES

DETECTIVE Profession, easy home study: free tie-tack or lapel pin, certificate, future. Professional Investigators Training School, Dept. CB, P.O. Box 1890, San Pedro, CA 90733.

FINGERPRINTING - exciting scientific career. Home study course teaches everything. Certificate on completion. Many openings; prepare now. Professional Investigators Training School, Dept. FP, P.O. Box 1980, San Pedro, CA 90733.

77 LOANS BY MAIL

GET cash grants—from Government. (Never repay.) Also, cash loans. All ages eligible. Complete information, \$2 (refundable). Surplus Funds-PSG, 1629 K St., Washington, DC 20006.

IMMEDIATE Cash Loans! No collateral, co-signers, interviews. 98% Accepted! Associates, Box 98-P3, Brooklyn, NY 11235.

BORROW By Mail! Free Details! MBG-PS30, Box 2298, Sandusky, OH 44870.

QUICK Cash \$ Signature Loans! Advance amount & purpose. National, 507 - PS Fifth Ave. New York 10017.

BORROW FROM HOME

ANY amount, any purpose, within 30 days. Competitive rates. Also, you can earn unlimited income as our Money Agent. No experience - own hours. National Company to assist every way possible. No gimmicks! Free Details: Financial, Dept. 11-C-3, 1145 Reservoir Avenue, Cranston, RI 02920.

BORROW \$25,000 "overnight." Any purpose. Keep indefinitely! Write: Success Research, Box 29263-FC, Indianapolis, IN 46229.

78 WINEMAKING

WINEMAKERS—BEERMALERS Free Catalog. Fast Service. Large Selection. Kraus, Box 7850-N, Independence, MO 64053.

FREE ENCYCLOPEDIA WINEMAKING BEERMALERS, supplies, equipment, ingredients. Vynox Industries, Box S7498, Rochester, NY 14615.

WINEMAKERS — Beermakers. Free Catalog. Equipment Supplies. Continental, Box 68016-PS, Indianapolis, IN 46268.

WINEMAKERS - Beermakers: Free Illustrated catalog of supplies. Semplex, P.O. Box 12276H, Minneapolis, MN 55412.

BEER — Winemaking Supplies. 42 Imported Malts. Catalog. Wine Hobby, P.O. Box 1866, Allentown, PA 18105.

BATHTUB Gin. Doctor's original prohibition recipe. Delicious, quick, saves money. Send \$5.00 to: Recipe, 322 Tenth, Wakeeney, KS 67672.

BEERLOVERS! Brew American and European Beer. Complete Kits. Equipment. Supplies. FREE Details. Duane Imports Ltd., Department PS30A, 508 Canal Street, New York, NY 10013.

79 BUY IT WHOLESALE

REPLACEMENT PARTS for Chainsaw, Motorcycle, Snowmobile, Small Engines. Wholesale prices. 48 hour shipment. Free Catalog. Manufacturer's Supply, Box 157PS, Dorchester, WI 5425.

400,000 BARGAINS Below Wholesale! Many Free! Liquidations Closeouts! Job Lots! Single Samples. Free details. Worldwide Bargainhunters, Box 730-B, Holland, MI 49423.

80 ADVERTISING AGENCIES & SERVICES

EXPERT Assistance for mailorder, advertisers. Ratebook leading newspapers, magazines \$1.00. Chicago Advertising Agency, 28-ES Jackson, Chicago 60604.

MARKET Consumer Products on National Television at No Cost. (215) 623-4566.

83 RUBBER STAMPS & OFFICE SUPPLIES

RUBBER Stamps. Free Catalog. Jackson's, Brownsville Rd. G-100, Mt. Vernon, IL 62864.

85 PRINTING & RUBBER STAMP OUTFITS

PRINT YOUR OWN — Printing Presses. Type, Supplies Direct From Factory. Send 25c for Catalog and Samples to: Kelsey Company, DS, Meriden, CT 06450.

SIMPLE-X RUBBER STAMP PRESSES. Hydraulic Operated. Electrically Heated. Sizes 5"x8", 8"x12", 10"x15". Starting OUTFITS. Order for Presses. Supplies Shipped Day Received. Send \$2.00 for Catalog and Brochure. Custom Manufacturers, Box 211-PS, Springfield, MO 65801.

87 TOBACCO, PIPES, CIGARS

"FREE" PIPE TRIAL—FREE TOBACCO! Get 1 lb. of tobacco free when you try Carey "Magic Inch" pipe free for 30 days. Write: E.A. Carey, Dept. 462C, 639 Academy Dr., Northbrook, IL 60062, or call 800/621-5199 (In Illinois 800/972-5855).

88 OLD GOLD, JEWELRY WANTED

GOLD - Silver - Platinum Wanted. For free information write: Wilmons, 345 S. Glassell, Orange, CA 92666.

HIGHEST CASH IMMEDIATELY for Old Gold, Silver, Platinum, Jewelry, Gold Teeth, Watches, Diamonds, Spectacles. Free information. Rose Industries, 29-Y East Madison, Chicago, IL 60602. Established 1934.

BUYING Gold - Silver! Free Details! Reliance, 50-PS3 Margin, Salem, MA 01970.

HIGHEST CASH for Gold, Jewelry, Gold Teeth, Rings, Diamonds, Watches, Silver, Platinum, Mail Articles Today. Free gift with information. Chicago Gold & Precious Metals, 6 E. Monroe, Dept. 757, Chicago 60603.

89 WATCHES, CLOCKS— SALES & SERVICE

WATCH and Clock Repairing Books, Tools, Materials. Free Catalogs. North American, Box 77-BP, Fox River Grove, IL 60021.

90 GIFTS

A HANDFUL OF INSTRUMENTS

The new **"SELECTO 5 PLUS"** (pat. pend.) is a chrome-finished quality instrument in the form of a retractable pen which gives you (1) a tungsten-carbide tipped engraving tool, (2) a sharp double-ground knife blade, (3) adjustable lead pencil, (4) a blue ball-point pen, and (5) a powerful magnet at the top of the instrument. PLUS interchangeable red ball point pen, 18 lead refills, 4 pen refills. In attractive gift box, only \$17.95 + \$2 insured shipping & handling. Residents of following states add applicable sales tax: CA, CO, FL, IL, NY, PA, VA, VT, WI. Send check or money order to: Popular Science Selecto 5, Dept. 4014-MAO, P. O. Box 5115, Grand Central, New York, NY 10017.

91 OF INTEREST TO ALL

SIREN LIGHT for joggers. Lightweight flashlight has built in siren. Measures 8" and runs on 2 "C" batteries (not included). \$7.50. Alva House, 7700 Leesburg Pike, Suite 102P, Falls Church, VA 22043.

\$83,501 WORTH Government Benefits Owed You \$3.00. JN Publications, Box 313, Cedar Lake, IN 46303.

92 MODELS—SHIPS, CARS, PLANES, ROCKETS

BUILD museum-quality ship models, gun models, dollhouse room settings. 1980 Model Catalog features complete kits, fittings, plans, construction materials, tools. "How-To" books. 88 pages. Only \$1.00. James Bliss & Company, Dept. PS, Route 128, Dedham, MA 02026.

94 FOR INVENTORS

NONPROFIT foundation helps inventors. Widest range of services. Free recording forms. Free evaluation. Affiliated Inventors Foundation, 501-A Iowa, Colorado Springs, CO 80909.

PATENT ATTORNEY—Serves Inventors By Mail. Box 405, Medfield, MA 02052.

PATENT IT ECONOMICALLY! Free details. N. Rainer, 2008 Fondulac Rd., Richmond, VA 23229.

REGISTERED PATENT ATTORNEY. Applications and Searches. Mail Service. Free Preliminary Review. Box 392, Millwood, NY 10546.

NEED HELP, INFORMATION? SOCIETY OF AMERICAN INVENTORS. Rte. 4, Box 419-F, Savannah, GA 31405.

IDEAS, inventions, new products needed by innovative manufacturers. Marketing assistance available to individuals, tinkerers, universities, companies with feasible concepts. Write for Kit-PS, IMI, 701 Smithfield Street, Pittsburgh, PA 15222.

INVENTORS - Patent Your Invention. Free Initial Consultation. We are registered by the U.S. Government. Victor J. Evans & Co., 4637 Eastern Ave. N.E., Washington, DC 20018. Since 1898.

NEW! "Patenting Your Invention Yourself." \$29.95. Patent Attorney, 7400-PS Benjamin Franklin Station, Washington, DC 20044.

LEARN how to offer your invention for sale or license. Free Booklet Outlines procedures, royalty rates, requirements. Kessler Sales Corporation, C-73-FI, Fremont, OH 43420.

PATENT LAW CLINIC, established by registered practitioners, provides patent services for reasonable fees, 9359-S Torrent Row, Columbia, MD 21045. (301) 997-9280.

95 INVENTORS WANTED

INVENTURE, Inc.—invention/patent marketers, PhD. Free inventor information. 304-S Main Street, Ft. Lee, NJ 07024. 201/947-7480.

INVENTORS: Free information on offering your invention for sale. Kessler Sales Corporation, C-73-IW, Fremont, OH 43420.

INVENTIONS WANTED

FREE CONSULTATION • NO IDEA TOO SMALL Disclosure registration. Potential cash or royalties from manufacturers seeking new ideas. For free information on how to register your ideas. Call or Write

American Inventors Corp.

59 Interstate Dr. Dept PS
West Springfield, MA 01089 (413) 737-5376
A Fee Based Service Company

100 WANTED TO BUY

QUICKSILVER, platinum, silver, gold! Ores analyzed. Mercury Terminal, Norwood, MA 02062.

GOLD, Silver, Platinum! Free information! American Metals, Box 30009-PS, Charleston, SC 29407.

LAMPS, OLD TIFFANY TYPE. Pay to \$1200.00. Photo, Box 897P, Lake Forest, IL 60045.

SCRAP Silver Electrical Contacts. Send Sample for my offer. R. Leszczak, 652 Myrtle Street, Elizabeth, NJ 07202. (201) 353-5049.

DELTA Scroll (Jig) Saw. W. D. Haentjens, Box Q, Hazleton, PA 18201.

102 TREASURE FINDERS, METAL DETECTORS

FIND old coins, jewelry, gold nuggets. New patented revolutionary device. Free catalog. Gardiner, 4729L N. 7th Ave., Phoenix, AZ 85013.

GOLD DREDGE PLANS, Also complete information, laws, and forms on staking a mining claim. Send \$5.00 to: Gold, Box 907, Los Banos, CA 93635.

104 VACATIONS, RESORTS, TRAVEL

YOUR PERFECT TRAVEL COMPANION

The North American Road Atlas from Gousha, for over 50 years the nation's foremost road map publisher. Beautiful, full-color, 128-page easy-to-read atlas covers U.S., Canada & Mexico. Even includes maps of 212 cities. Major parks, historic sites & points of interest clearly marked. Mileage charts, too. You'll find it the best road atlas you ever owned. Order directly from Popular Science for just \$3.95 + \$1 postage & handling. (Residents of CA, CO, FL, IL, NY, PA, VA, VT & WI, please add applicable sales tax.) Popular Science Road Atlas, P. O. Box 5115-MH Grand Central, New York, NY 10017. Quantity prices (50 or more) on request.

105 MISCELLANEOUS

HISTORICAL CASSETTE TAPE "KENNEDY PRESIDENCY." Mail \$5.00. Tower, Lewes, DE 19958.

FREE BOOK. Prophet Elijah Coming Before Christ. Megiddo Mission, Dept. 58, 481 Thurston Road, Rochester, NY 14819.

PROBLEMS SOLVED. \$100.00. Payment on satisfaction. The Psychic, Box 711, Nantucket, MA 02554.

BLACKJACK - New Strategy in Blackjack. Proven to Win. \$3.00. Blackjacks, Box 314, Bartlett, IL 60103.

MAGNETS All Types, Special — 20 disc, or 10 bar, or 2 sticks, or 8 assorted magnets, \$1.00. Magnets, Box 192-B, Randallstown, MD 21133.

ORNAMENTAL Iron designs. Book of 1600 beautiful practical designs for railings, columns, etc. Free literature. Cunningham, 3881 South 3200 West-P.O. Box 2005-S, Salt Lake City, UT 84120.

PROFITS in the Stock Market. Facts and proven method. Send \$4.95 to H. Messier, P.O. Box 123, Montgomeryville, PA 18936.

ANY, repeat **ANY**, businessman who owns a Level II, 16K TRS-80 can increase profits with this program, which costs only \$18.50. Free information: Omni Systems Co., Dept. 3P, Box 29347, Minneapolis, MN 55430.

106 PERSONAL

INVESTIGATORS. Latest Electronic Aids. Write: Clifton, Box 220-F, Miami, FL 33168.

COLLEGE DIPLOMAS WITHOUT CLASSES. Accredited Degrees by Mail. Free Details. EACS. Box 33428, Seattle, WA 98133.

ADVANCED TITLES/DEGREES Ministers, Honorary Doctorates, other Services available. Omnidenominational. Free Details. Aquarian Church, 432-PS PCH, Hermosa Beach, Ca 90254.

BECOME An Ordained Minister. Free ministerial credentials legalize your right to the title "Reverend." Write: Church of Gospel Ministry, 486-PS Skyhill Court, Chula Vista, CA 92010.

TOTAL Mind Power (How to use the other 90% of your mind). Free Booklet. Total Mind Power Institute #18, Larkspur, CA 94939.

END money worries forever! I made \$77,000 last year. Paid hardly any taxes. You can too. Free proof! Sterne, 8361-N Vickers, San Diego, CA 92111.

EASY Winning Blackjack. Unique cassette tape. One instruction hour. No charts to memorize! Fascinating inside information revealed. Guaranteed. \$9.95 ppd. C.C. #PS380, Box 3059, Carson City, NV 89701.

UNIVERSITY DEGREES BY MAIL. Legal, Fast, inexpensive. Free revealing details. Counseling, Box 389-SP3, Tus-tin, CA 92680.

PLAY CRAPS TO WIN! New Business Approach. Computer Tested. Guaranteed. Send \$5.00 Today. Felicity Systems A030, Box 113, Westminster, CA 92683.

CERTIFICATES, Documents (all kinds) Guaranteed! Authentic!! Catalogue 25c: LTD Documents, Box 3910-M9, New Hyde Park, NY 11040.

DIVORCE - Beat the racket! Fight discrimination! Literature, Attorneys. Free info. MEN'S RIGHTS ASSOC., Box 189A, Forest Lake, MN 55025.

106A HAIR CARE

CURE FOUND FOR MALE PATTERN BALDNESS. DISCOVERED BY DOCTOR AT THE UNIVERSITY OF HELSINKI, FINLAND WHILE DOING CANCER RESEARCH. FREE REPORT. CONAN RESEARCH, P.O. BOX 442, TWINSBURG, OH 44087.

107 HEARING AIDS

HUGE SAVINGS. Eliminate dealer markup. Free Trial, Batteries wholesale. Terms Arranged. Lloyds-PSC, Rockford, IL 61104.

NEW - Hearing Aids, Batteries, Discount Prices, Free Details. Write: Rhodes, Dept. 69-M, Brookport, IL 62910.

FREE HEARING AID CATALOG - Save 1/2 by Mail! Write: "MONEY-SAVERS", 9530-PS3 Langdon, Sepulveda, CA 91343, Not sold in California.

No-glue doweling

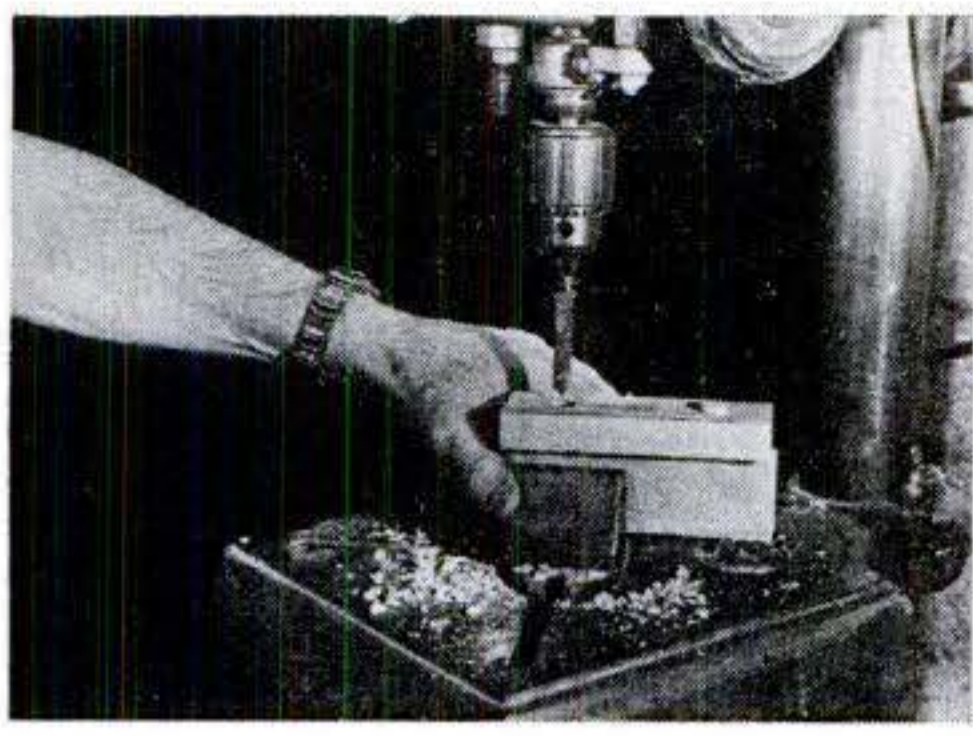

Flat bit, with upper counterbore and stop, prepares hole for dowel and sleeve.

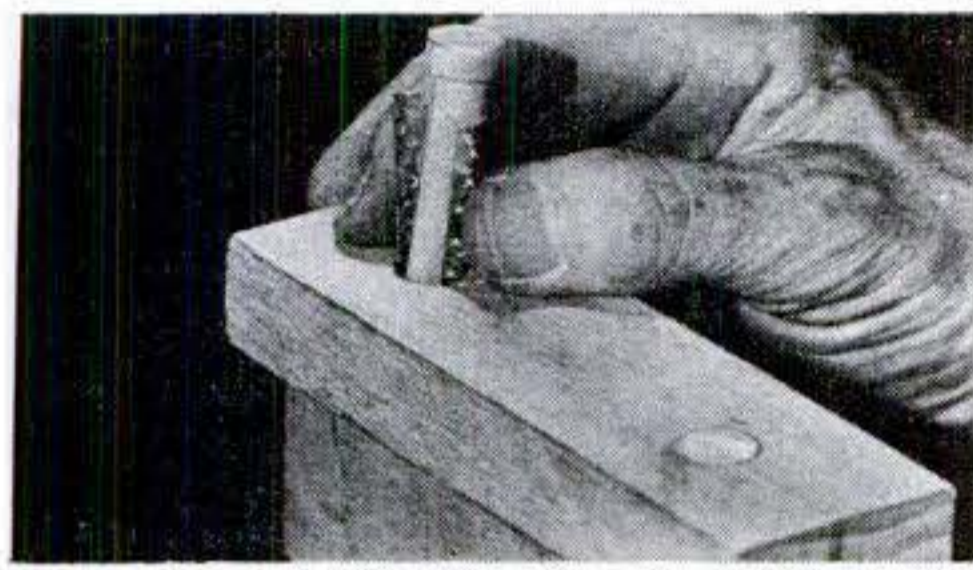

Gripper strip is folded and dropped in, followed by dowel, which drives in snugly.

If you have to take apart and reassemble furniture, and you find gluing messy or tedious, Musgrip fasteners can make the job simpler. Originally invented for assembling hard-to-fasten chipboard, they require no glue, hold firmly, and work equally well in hard or soft woods.

To insert, you drill the dowel hole to the proper depth and diameter, using a special, inexpensive flat bit with a counterbore cutting section and a stop at the top. Then you fold the toothed metal gripper strip (lower photo) into a V, insert it in the hole, and drive the dowel flush. You can camouflage the dowel cap by covering it with a layer of veneer, aligned with the grain of the wood. To remove the dowel, drill a hole in it, insert a wood screw, and pull out with a claw hammer.

U.S. marketing is planned by Musgrip Wood Fasteners, 12 Livingston Rd., Pinetown 3600, Natal, South Africa.—*E. F. Lindsley*

Fixing a leaky toilet tank

To fix a leak when the stopper plug isn't seating, drain the tank; then cut off the plug at the stem so you can chuck it in a portable drill. With water-soluble grinding compound on the plug, lap the seat—first with coarse grain, then with fine. A new plug should fit tightly.—*A. A. Patrick*

CONSERVE ENERGY

Your

Electrify your Bike...



PEDALPOWER-Exciting new powerful electric drive for bikes. Tames tough hills. Be independent. Shop when you want. Fits all bikes and adult trikes. Easy to use and install. Beat high gas prices. Recharges overnight at home. Travel 100 miles for a dime.

Get your exercise without strain. Pedal easily with motor engaged to help improve your health. Visit friends. Travel to work or ride for fun. Starts without pedaling. Noiseless, non-polluting. Virtually maintenance-free operation!

Thousands in use today by senior citizens, students, housewives, workers, handicapped and professionals. Call today or write for free booklet with complete details on PEDALPOWER motors, Take-Apart Electric Bikes and Adult Electric Tricycles.

Call Toll Free
800-257-7955*

For this **FREE BOOKLET** & Special Offer or Write:



General Engines Co.
5639 Mantua Blvd.
Sewell, NJ 08080



* In AK, HI, NJ call collect (609) 468-0270

Earn \$200 a day working part-time - as a chimney sweep

Soaring demand caused by energy crunch and increasing wood-burning. Low investment, flexible hours, good repeat business. Ground-floor opportunity for basic community service. Ask for free details.

Black Magic Chimney Sweeps

Box 250, Dept. PS3
Stowe, Vt. 05672 802/253-4867

Save Gas-Add Power

Look at these features!
Gas Mileage increased 10-30%
Power increased, 10-20%
Increased torque through RPM range
Prevents overheating
Rotation-smooth and steady
Less carbon deposit
Easy starting
Less pollution
Prolongs engine life
Plus!
A lifetime guarantee
A 60-day money back guarantee

It's here! A new Japanese product from Sekon which gives you a solution to High Torque, High Power, and Less Fuel, simultaneously!

SWARUP is a static mixer which partially rotates the fuel-air mixture in the manifold in different directions.

SEKON SEKON INTERNATIONAL
SEKON INT'L CORP. OF AMERICA
2210 Wilshire Blvd.
Suite 577 PS
Santa Monica, CA 90403
(213) 393-9791

| | |
|-----------------------|---------|
| One barrel carb..... | \$38.95 |
| Two barrel carb..... | \$48.95 |
| Four barrel carb..... | \$68.95 |

World Wide Patent Pending
Distributors and Dealers needed

Always Include Your Zip Code When Answering Ads

Popular Science Indexes

380 Madison Avenue, New York, N.Y. 10017

Enclosed is a total of \$ _____ (check or money order). Please send:
 1978 1977 1976 1975 1974 1973 1972
 (send \$1.75 for each index above) All seven indexes (1972-1978) for \$7.00

Name _____
 Address _____
 City _____
 State _____ Zip _____

(The above includes postage and handling. Allow approximately 4 weeks delivery.)

YOU SAW IT IN POPULAR SCIENCE - BUT WHEN?

COUNTERFEIT GUNS

AUTHENTIC! FULL SIZE MACHINED METAL MODELS
Museum quality precision machined metal classics weigh, look and feel like real guns. Will fool experts. Perfectly legal—CANNOT BE FIRED. Blued and disassemble like originals. Decorate your den, office, rec-room. Send for **FREE FULL-COLOR CATALOG**. Made of over 30 blued, hand-finished parts—**DELIVERED FULLY ASSEMBLED.**

SAME SIZE AND WEIGHT AS THE ORIGINALS!
MONEY BACK IF NOT SATISFIED!
GOVERNMENT .45

STANDARD SIDEARM OF G.I.'S. SLIDE WORKS LIKE ORIGINAL WITH SAFETY THAT WORKS. LGTH. 9 1/2". WT. 2 1/2 LBS.
DISASSEMBLES LIKE ORIGINAL. Model R300 \$44.95
ADD \$1.50 POSTAGE/HANDLING

REPLICA MODELS, INC., P.O. BOX 1061
DEPT. PS038 800 SLATERS LANE, ALEXANDRIA, VA 22313

Send \$300 Send **FREE COLOR CATALOG**
Charge to: BAC Mastercharge Am. Express Diner's Club

(LIST ALL NUMBERS ON YOUR CARD)

NAME _____
 ADDRESS _____
 CITY/STATE/ZIP _____

MONEY BACK IF NOT SATISFIED

Subscriptions cut to \$2.97! mind-boggling announcement

Publisher slashes price to
celebrate Tenth Anniversary

By R. GINZBURG

NEW YORK
Moneysworth, the monthly magazine, has stunned the publishing world by announcing an offer of full-year subscriptions for \$2.97. This is as little as some magazines charge for a single issue.

"We're doing this to celebrate our Tenth Anniversary," a spokesman said, "and to solidify Moneysworth's position as America's Number One Biggest Publishing Bargain. Ever since it began publication in 1970, Moneysworth has consistently lowered subscription rates, while other periodicals have raised theirs. We started out at \$10 a year and now are offering Tenth Anniversary Special Subscriptions at *THE UNREAL PRICE OF ONLY \$2.97!*"

Moneysworth, which tells how to get the most for your money and the most out of life, is read by an estimated 5,000,000. Its chief competitors are Consumer Reports, which sells for \$12 a year, and Money magazine, for \$14.95.

How to place your order

Readers of Popular Science who wish to take advantage of this unparalleled offer should send their name and address with \$2.97 to: Tenth Anniversary Special Subscriptions, Moneysworth, General Post Office Box 7777, New York, NY 10001.

Typical of the savvy, wallet-fattening articles Moneysworth prints are these:

Recession-Proof Jobs

Cars that Are Stingiest with Gas

How to Earn 10½% on Your Savings

Canada's FREE Land Giveaway

How to Cope with Dunning Letters

How to Qualify for Food Stamps

The Long and Short of Hair Transplants

How to Collect Social Security from the
U.S. and Canada—BOTH

Are Hay Fever Shots Pointless?

Mercedes' New "Lifetime" Car

How to Reduce Exorbitant Doctor Bills

States with Best Unemployment Pay

How to Get a Low-Cost Divorce

The Kinds of Cars Mechanics Own

How to Hold On to Your Auto Insurance

How to Turn Boxtops into Gold

Contact Lenses that CURE Poor Vision

Happiness Is a Hick Town

A Gourmet's Guide to Free Cookbooks

How to Stop Snoring

Air Travel at 50% Off

Today's Soldiers Command High Pay

Prosperity in Alaska

Low-Cost Insurance for Non-Smokers

Mattresses to Turn Handsprings Over

How to Save 20% on Your Food Bill

Scholar Dollars for the Middle Class

Where Retirement \$\$ Goes Farthest

The "Yurt": Incredible \$350 House

How to Get 7 Bestsellers for Price of 1

Ski Areas Without Steep Prices

How to Burn Wood Efficiently as Fuel

Resumes that Get Jobs

How to Avoid Alimony

How to Travel and Get Paid for It

Fifteen Fabulous Free Maps

Don't Sneeze at This Cold Remedy

Starting a Retirement Business

The World's 100 Best Free Calendars

Landing an Executive Job After 40

The Only Diet that Really Works

Sailboats that Are Real Winners

Getting a Job as a Forest Ranger

The Amazing New Two-Engine Car

As you can see, Moneysworth is an easy-to-follow instruction manual for building a better life.

Each day, its editors are inundated with ecstatic testimonials like these:

• "You're not going to believe this, but I have parlayed \$146 into \$90,000 due to your informative article on how to break into real estate. How can I ever express my gratitude sufficiently?"
—H. Pinrose; Montgomery, Iowa.

• "Your advice on Social Security resulted in a \$3,135 lump-sum cash payment to my wife and \$171 monthly pension. The best investment I ever made was my subscription to Moneysworth."
—Dr. Herman Hortop; La Grange, Ill.

• "Your tip on flying to Europe via Afghanistan saved me \$450. You've made me a subscriber for life."
—Charles B. Fager, M.D.; Harrisburg, Pa.

• "Your article on high interest paid by foreign banks has enabled me to retire in style. I cannot thank you enough."
—E. Svenson; Fallbrook, Cal.

• "Your news reports on investments have brought me, in just months, \$12,996 profit, tripling my money. You can bet I shall be a Moneysworth subscriber for life."
—L. Gray; Ypsilanti, Mich.

• "Your article 'Inaccurate Billing by the Phone Company' led me to discover four years of overcharges. I got a \$1,593 refund!"
—A. DiRienzo; Bristol, Pa.

• "Moneysworth's product ratings sure stretch the dollar. I bought the 35mm camera you recommended, saving 30%."
—R. Goodrich; Tucson, Ariz.

• "Your article 'How to Avoid Paying an Exorbitant Doctor Bill' saved me \$65. Here's my subscription extension."
—C. Wagner; Yorktown Heights, N.Y.

“ This Tenth Anniversary
Special Subscription
Offer is highly recom-
mended to readers of
Popular Science ”

• "Thanks to your article 'How to Buy a New Car for \$125 over DEALER'S Cost,' I just bought a Chevy at a saving that I conservatively estimate at \$350."
—Rudy L. Grange; Anita, Iowa.

• "Moneysworth is aptly named. To paraphrase Churchill, never have so many paid so little for so much."
—Dave Alpern; Pittsburgh, Pa.

To take advantage

To take advantage of this GIVEAWAY offer, readers of Popular Science should send their name and address with \$2.97 to: Tenth Anniversary Special Subscriptions, Moneysworth, General Post Office Box 7777, New York, NY 10001.

If ever a publication was accurately named, it's Moneysworth. This offer is highly recommended.

The mobile amusement park.



Trucks are what we're all about.

Wouldn't it be grand for a change to be able to take your fun with you, instead of having to go where it already is?

Oh sure, you could tie down a canoe on the top of the car, put dirt bikes on a carrier, or fill the trunk and back seat with all kinds of camping gear. But that gets a bit tiresome. And can you really take the old 4-door along the rough, secret "road" to Hidden Vista Point?

Consider instead, a very practical and delightfully liberating alternative: a GMC pickup.

They're incredibly sensible. Built strong and tough. And range from half-ton to one-ton models. They can be equipped to tow up to 12,000 pounds. So boats, outboards, bikes and lots of coolers become routine cargo. Plus, the available 4-wheel drive helps you wander off the all-too-well-beaten path.

To help fight rust, some steel parts have been specially pre-coated and treated with zinc-rich compounds. (All GMC's are covered by a 3-Year Perforation from Corrosion Limited Warranty. Exhaust systems are not included. Ask your GMC dealer for details on other limitations.)

Lots of comforting options are available, too. Like power assists. Air conditioning. AM/FM stereo. And more.

If you like the idea of mobile amusement, we think you'll like the idea of a GMC pickup. Talk to your GMC dealer about buying or leasing one soon. You might be in for a good time.

1980 GMC Pickup

EPA Est. MPG

Est. Driving Range With Optional Auxiliary Fuel Tank
576 Miles

18

Remember: Compare the estimated MPG to the "estimated MPG" of other vehicles. Your mileage and range will depend on your speed, weather and trip length. The range estimate is obtained by multiplying the EPA estimate by the 32-gallon fuel tank capacity. This includes the standard 16-gallon fuel tank plus the optional 16-gallon auxiliary fuel tank for a total of 32 gallons. Estimates lower in California.



GM
GMC is a division of General Motors.

MARK OF EXCELLENCE

Come to
Marlboro Country.



Famous Marlboro Red and Marlboro Lights —
either way you get a lot to like.

Warning: The Surgeon General Has Determined
That Cigarette Smoking Is Dangerous to Your Health.

Lights: 12 mg "tar," 0.8 mg nicotine — Kings: 17 mg "tar,"
1.0 mg nicotine av. per cigarette, FTC Report May '78