



POP  
6050

HARVARD UNIVERSITY.



LIBRARY

OF THE

MUSEUM OF COMPARATIVE ZOOLOGY.

6413  
From the  
Engineering Department  
L. S. S.

March 5, 1910.











THE

POPULAR SCIENCE  
MONTHLY.

*CONDUCTED BY E. L. YOUMANS.*

VOL. IV.

NOVEMBER, 1873, TO APRIL, 1874.

<sup>A</sup>  
NEW YORK:  
D. APPLETON AND COMPANY,  
549 & 551 BROADWAY.  
1874.

ENTERED, according to Act of Congress, in the year 1874,  
By D. APPLETON & CO.,  
In the Office of the Librarian of Congress, at Washington.





JOSEPH NORMAN LOCKYER.



THE  
POPULAR SCIENCE  
MONTHLY.

---

NOVEMBER, 1873.

---

LIBERAL EDUCATION OF THE NINETEENTH CENTURY.<sup>1</sup>

BY PROF. WILLIAM P. ATKINSON,  
OF THE MASSACHUSETTS INSTITUTE OF TECHNOLOGY.

THE collapse of that classical system of liberal education which has held almost undisputed sway since the revival of learning in the sixteenth century, and the now generally recognized insufficiency of the theory which makes the study of the languages of Greece and Rome the sole foundation of the higher education, are leading, as all familiar with the educational thought of the present day are aware, to the greatest variety of speculations as to the system which is destined to supersede it. That a theory of liberal education as well adapted to the wants of the nineteenth—or, shall we not rather say the twentieth—century, as was the classical theory to the wants of the sixteenth, has yet been elaborated, would be quite too much to affirm. We are living in the midst of a chaos of conflicting opinions, and it seems to be the duty of all who think at all on a subject on which the vital interests of the future so much depend, and especially incumbent on all practical teachers to make such contribution as they are able, from their studies and reflection or their experience, toward the right solution of the problem. It is to such a contribution that I now ask your attention.

I begin with a definition of Liberal Education, in regard to which I presume we shall not be much at variance. The term liberal is opposed to the term servile. A liberal education is that education which makes a man an intellectual freeman, as opposed to that which makes a man a tool, an instrument for the accomplishment of some ulterior aim or object. The aim of the liberal education of any period is the right use of the realized capital of extant knowledge of that period, for the training of the whole, or only of some privileged part of the

<sup>1</sup> A paper read in the Department of Higher Instruction at the annual meeting of the National Teachers' Association at Elmira, N. Y., August, 1873.

rising generation, to act the part and perform the duties of free, intellectual, and moral beings. So far as the nature of the human mind and the foundations of human knowledge remain the same from age to age and generation to generation, a liberal education is the same thing in every age and generation; so far as the condition of society varies from age to age, and as the accumulated capital of extant knowledge increases, the liberal education of one generation will differ from that of another. There are, therefore, both constant and variable factors in our problem. It is with the variable factors, as modifying our conception of the liberal education of the nineteenth century, that I have here chiefly to do.

I reckon five leading influences which are acting powerfully to modify all our old theories, and slowly working out a new ideal of liberal education: 1. A truer psychology, giving us for the first time a true theory of elementary teaching. 2. Progress in the science of philology, enabling us to assign their right position to the classical languages as elements in liberal culture, and giving us, in modern philological science, an improved and more powerful teaching instrument. 3. The first real attempt to combine republican ideas with the theory of liberal education—in other words, to make the education of the whole people liberal, instead of merely the education of certain privileged classes and protected professions. And when I say the whole people, I mean *men and women*. Nothing, I will say in passing, to my mind so marks us as still educational barbarians, so stamps all our boasted culture with illiberality, as an exclusion of the other sex from all share in its privileges. No education can be truly liberal which is not equally applicable to one sex as to the other. 4. As the influence more profoundly modifying our conceptions of liberal education than any other, I reckon the advent of modern physical science. 5. I count among those influences the growing perception that art and æsthetic culture are equally necessary as an element in all education worthy of the name. Let me give the few words, which are all the time will allow me, to each of these influences.

And, first, the advance we have been making toward a truer education-philosophy, based upon truer conceptions in regard to the growth and early development of the human mind, is pretty well disposing of what, perhaps, I may be permitted to call the old-fashioned, grindstone-theory of elementary education; the doctrine, namely, that, as preparation for higher culture, all youthful minds require a certain preliminary process of sharpening upon certain studies, valueless or next to valueless in themselves, at least so far as regards the vast majority of their recipients, but quite as needful, nevertheless, to them as to all others who are hereafter to be considered as liberally educated, for the indirect benefit their pursuit was supposed to confer. The accepted theory of liberal education has heretofore been, that it was a certain very special kind of training which required this peculiar pre-

liminary sharpening process, and that, as the instruments for it, there were certain almost divinely-appointed studies exclusively set apart, to wit, the grammars of two dead languages, and the elementary portions of abstract mathematics. It was not and could not be maintained that these studies would ever be the natural choice of the youthful mind in the beginning of its scholastic career; rather, it was thought to be a prime recommendation that they were as remote as possible from any thing the youthful mind would of itself appropriate as intellectual nutriment. Like medicine, the value of such disciplinary studies was supposed to be in direct proportion to their disgustfulness; for they were not food to nourish the mind withal, but tonics, wherewith artificially to strengthen it. They were rods for the spiritual part, the counterparts of those material ones which the strong right arm of the ancient pedagogue wielded with such efficiency on the bodies of his youthful charge, and the benefit of both alike was not utilitarian, but disciplinary.

That I may not be suspected of caricaturing, I will make two quotations, the first from a lecture by Prof. Sellar, Professor of Greek in the University of Edinburgh: "The one extreme theory," he says,<sup>1</sup> "is that education is purely a discipline of the understanding; that the form of the subject is every thing, the content little or nothing. A severe study, such as classics or mathematics, is the thing wanted to train or brace the faculties; it does not matter whether it is in itself interesting or not. The student will find sufficient interest in the sense of power which he has to put forth in training for the great race with his competitors. 'It is not knowledge,' they say, 'but the exercise you are forced to incur in acquiring knowledge that we care about. Read and learn the classics simply for the discipline they afford to the understanding. You may, if it comes in your way and does not interfere with your training, combine a literary pleasure with this mode of study, but this is no part of your education. As teachers, we do not care to encourage it; we do not care to interpret for you the thought or feeling of your author. All such teaching is weak and rhetorical: we do not profess to examine into your capacity of receiving pleasure. Accurate and accomplished translation, effective composition in the style of the ancient authors, thorough grammatical and philological knowledge—these are our requirements. The training in exactness, in concentration, in logical habits, and in discernment of the niceties of expression, is the one thing with which we start you in life. Whether you have thought at all, or care to think about the questions which occupy and move the highest minds, is no affair of ours.'

"This theory is, I think, a purely English theory of education. It has grown up within the last half-century, and it is in the University of Cambridge that it has been, and still is, most fully realized."

My other extract shall be from an essay by the Public Orator of the

<sup>1</sup> "Theories of Classical Teaching: A Lecture," p. 10.

University of Cambridge: "I conclude, then," says Mr. W. G. Clark, "that the first subject of study must be the same for all, and that it is no valid objection to any subject to affirm that it is dry and distasteful, but, on the contrary, a strong recommendation. It cannot be denied that this condition is amply satisfied by the Latin accidence, as exhibited in our time-honored and much-abused text-books. . . . The question arises where, besides the Latin grammar, we can find any other subject equally dry, and by consequence as powerfully tonic to the juvenile mind, which recommends itself as deserving in lieu thereof to form the basis of education by its general applicability and greater fertility of after-results. Except the Greek language, which, from its intimate connection with the Latin in structure and literature, is a necessary complement to it, and not a possible substitute for it, I know of none."

Here we have the very essence of what I have denominated the grindstone-theory. I think that a truer philosophy has exploded these fallacies, and wellnigh obliterated that artificial line of distinction between studies for use and studies for discipline. True education remains and must remain forever a discipline; but juster views in regard to the nature of the youthful mind are beginning to show us that that discipline is of the nature of a nutritive rather than a curative process, and that the disgust felt by the recipient for the means employed is no measure of their disciplinary value. We are discovering that the idea of discipline inheres not in the nature of certain particular subjects, distinguishing them from all others which are non-disciplinary and merely utilitarian, but in the right method of teaching all subjects; and the question, whether at any particular period or stage of progress a subject is to be used for purposes of mental discipline, depends not at all upon the question whether it belongs to one or the other of two imaginary classes, the disciplinary and the non-disciplinary, but upon the quite different questions whether the study is valuable in itself, and whether it is suited to that particular stage of the pupil's mental progress. If so, and if rightly taught, it will then be sure to be the right discipline.

This change in our education-philosophy has brought with it a corresponding change in our scale and estimate of the relative value of various studies as the instruments and materials of education; and, I think, we have almost heard the last of the doctrine that abstract grammar and abstract mathematics are the divinely-appointed whetstones and sharpeners of the youthful mind, and hence of the system which makes a compulsory study of the Greek and Latin languages the only gate of admission to the privileges of the higher education. In place of that very simple but most unphilosophical doctrine, I trust that a truer psychology is providing us with a course of liberal study, based upon correcter notions in regard to the laws of mental develop-

<sup>1</sup> "Cambridge Essays," for 1855.

ment. That we have such a completed practical psychology, or any such logical and symmetrical course or courses of study based upon it, is more than can be asserted, for education, as a science, is still in its infancy; but we certainly have attained to certain general principles which are fundamental as regards the elementary education of the future; and the most important of these, which is even now revolutionizing all our methods of elementary teaching, is the direct result of the progress of modern physical science. It is, that education begins with the concrete, and not with the abstract, and that the right method for the teaching even of language itself is the right training and development of the child's senses. The Latin grammar, therefore, as the right instrument for training the youthful mind, is fast disappearing, along with that birch which was its material symbol and needful complement, and a *striking* witness to the absurdity of the use we put it to. *Requiescat in pace!* The lovers of the noble science of classical philology may well be congratulated on its emancipation from such degrading servitude.

In place of this rude and crude, and now happily obsolescent theory, a deeper philosophy is leading us to inquire into the nature of the undeveloped mind, and the true order of the development of its faculties, and is, at the same time, guiding us to the right choice of means for stimulating their natural and healthful growth and unfolding. And here I will say that the answer which psychology gives to these questions seems to me a little in danger of being misinterpreted for the time being by one class of educational reformers. In their reaction against the premature and unnatural stimulus given to the powers of abstraction by the old system, they are in danger of running into the opposite extreme of paying a too exclusive attention to the development of the observing powers in the new—a tendency which the influence of modern physical science on our educational ideas, especially, tends to foster. I doubt whether one extreme will prove any better than the other, for both are equally one-sided. The true lesson we are to learn is, above all things, to have regard to balance and proportion. The youthful mind is not a different thing from the same mind in its maturity. The germs of all faculties exist in it, and their development is in no linear order, but rather like rays diverging from one centre; and the true conception of the different stages of education is, as being divided by concentric circles, cutting those rays at equal distances from the centre. The child's observing powers should furnish him with intellectual material no faster than his powers of abstraction can work it up into intellectual products, or than the development of his powers of expression can give form to them. On the other hand, his powers of expression should never be developed in empty words, beyond the limits of his acquisition of the ideas words stand for, as is now the case with so much of our word-mongering education. Again, his imagination should never outrun his reason on the

one hand, nor his memory overload it on the other, in accordance with that preposterous doctrine we sometimes hear propounded, which advocates the employment of the youthful memory in laying up stores of unintelligible knowledge, in anticipation of an after-time, when it will become intelligible—as if there could be such a thing as not-understood knowledge, in any other sense than as we speak of undigested food—turning to poison in the system. The child is a philosopher, a moralist, a poet in little, quite as much as he is an observer or a rememberer, and his whole moral and intellectual growth will be warped and stunted so long as you insist upon looking on him as a mere observing or a mere memorizing machine, a mere receptacle for facts or for words either.

If I am right in this view of the true character of elementary education, it follows that the great departments, into which it should from the very first be divided, correspond exactly with the primary divisions of knowledge itself, as they will continue for the pupil forever after. Let me, for the purposes of this discussion, make a triple division of knowledge into physical, ethical, and æsthetical, according as our thought is concerned with the world of matter, the world of mind, and the world of art or beauty. I am concerned here less for strictness of philosophical accuracy than for the practical convenience of this division. Now, as, in accordance with our fundamental conception of liberal education, the question as to a choice between these departments of liberal learning is a futile one, because all are essential elements in our conception of liberal education—so, if I am right, no conception of elementary education can be a correct one that does not provide for them all from the very beginning.

I need hardly point out what a change in all our methods this change in our philosophy implies; for it involves the doctrine that the true place to begin the teaching of all art, all science, all knowledge, is the primary school; and I am not in the least afraid of the seeming paradox. Rather I would earnestly maintain that, unless we treat the child in the primary school as the germ and embryo of all he is destined afterward to become, our education will be doomed to ignominious failure. Whatever, therefore, enters into our conception of liberal education—and we have already seen that nothing less than all extant knowledge should enter into it—that should enter into it from the beginning. Language and literature should be the subjects of elementary teaching; science should be the subject of elementary teaching; art should be the subject of elementary teaching. Whatever is to enter into the higher stages of education is to have its seed planted there, or it never will be planted. The true distinction, therefore, between disciplinary and non-disciplinary, is not a distinction between one set of studies begun early and another set of studies begun late, one set of studies pursued for training, and another set of studies mastered for use: it is a distinction between the earlier and the later



stages of all studies whatever. The child, as well as the man, is linguist, student of science, artist, philosopher, moralist, poet, though his philology, science, art, philosophy, will be childish, not manly, germs and intuitions, not results of developed reason. Is it not obvious that in this view elementary schools become something far more than places for drilling the youthful mind in the use of the mere tools of knowledge? Is it not obvious, moreover, that, looked at from this point of view, a man's profession is only the outgrowth and fruitful consummation of his *whole* training; a divergence, when the time arrives that the whole of knowledge becomes too wide a field to cultivate, into some special fruit-bearing direction, which, whatever it may be, will lead to a truly liberal profession, inasmuch as by a man so trained his calling cannot but be followed in a liberal spirit?

We have in England and America no conception of what may be accomplished in the early stages of education, because we have been, to so great an extent, adherents of the grindstone-theory. "Nowhere," says Mr. Joseph Payne, commenting on the lamentable, almost ludicrous, failure of that embodiment of the grindstone-theory, applied to popular teaching through the medium, not of the Latin grammar, but of the three R's—I mean the so-called English "Revised Code"—"nowhere have I ever met, in the course of long practice and study in teaching, with a more striking illustration of the great truth that, just in proportion as you substitute mechanical routine for intelligent and sympathetic development of the child's powers, you shall fail in the object you are aiming at."<sup>1</sup> I think that the insignificant results of our present elementary schools, as compared with the amount of time, thought, and money, expended on them, and their want of real vitality, are to be mainly traced to this fundamentally false conception of elementary teaching as concerned only with the acquisition of the mere tools of knowledge.<sup>2</sup> By its fruits, or rather by its barren-

<sup>1</sup> "Of four-fifths of the scholars about to leave school, either no account, or an unsatisfactory one, is given by an examination of the most strictly elementary kind" (Report for 1869-'70). "We have never yet passed 20,000 in a population of 20,000,000 to the sixth standard; whereas old Prussia, without her recent aggrandizement, passed nearly 380,000 every year" (speech of Mr. Mundella, in the House of Commons, March 18, 1870). "What we call education in the inspected schools of England is the mere seed used in other countries, but with us that seed, as soon as it has sprouted, withers and dies, and never grows up into a crop for the feeding of the nations" (speech of Dr. Lyon Playfair, in the House of Commons, June 20, 1870). See the *Fortnightly Review* for August, 1873, and Payne in *Social Science Transactions* for 1872. If we should ever need—which God forbid!—a warning against the folly of substituting a sectarian for a national system of popular education, we may find it in the wretched perversion of English popular education in the hands of her Established Church.

<sup>2</sup> "What wonder if very recently an appeal has been made to statistics for the profoundly foolish purpose of showing that education is of no good—that it diminishes neither misery nor crime among the masses of mankind? I reply, Why should the thing which has been called education do either the one or the other? If I am a knave or a fool, teaching me to read and write won't make me less of either one or the other—

ness, we may know it; and I may add that it is because in our common schools we are completely outgrowing it, that day by day we see in them so much new life.

So much in regard to the debt which a liberal education is destined soon to owe to the progress of psychology, giving prevalence to truer views in regard to its rudimentary processes. Let me pass to the second influence, which is acting powerfully to modify all our previous conceptions of the subject; I mean the progress of modern linguistic science. I take this next in order because, contrary to the current of thought prevailing at the present moment, I believe the old doctrine will still be found to hold true, even after physical science shall have at last found its true place in the new education, that the study of that wonderful world of matter, which is the stage on which man plays his earthly part, wonderful as it is, is yet inferior in dignity and importance to the study of the being and doing of the actor who plays his part thereon. Scientific studies, though for the time being in the ascendant, yet, even when all their rights shall be accorded to them, will, in a well-balanced system, take their place a little below ethical studies. This, I say, as not believing in the current materialistic philosophy in any of its forms, but as being an immaterialist, as I must phrase it, since we have been robbed by unworthy and degrading associations of the word spiritualist. But, without raising any question of precedence between branches of study which are both essential to any true conception of a complete education, let me proceed to point out that the progress of linguistic science and of modern literature has totally transformed the educational character and position of the ethical studies of which they are the instrument and the embodiment. When the Revival of Learning gave birth to the present classical system of literary, or, as I have termed it, ethical liberal study, it did so by putting into the hands of scholars not merely two grammars as instruments of youthful mental discipline, as the advocates of the grindstone-system would fain have us believe, but two languages unless somebody shows me how to put my reading and writing to wise and good purposes.

“Suppose any one were to argue that medicine is of no use, because it could be proved statistically that the percentage of deaths was just the same among people who had been taught how to open a medicine-chest, and among those who did not so much as know the key by sight. The argument is absurd; but it is not more preposterous than that against which I am contending. The only medicine for suffering, crime, and all the other woes of mankind, is wisdom. Teach a man to read and write, and you have put into his hands the great keys of the wisdom-box. But it is quite another matter whether he ever opens the box or not. And he is as likely to poison as to cure himself, if, without guidance, he swallows the first drug that comes to hand. In these times a man may as well be purblind as unable to read—lame, as unable to write. But I protest, that if I thought the alternative were a necessary one, I would rather that the children of the poor should grow up ignorant of both these mighty arts than that they should remain ignorant of that knowledge to which these arts are means.”—(Huxley, “Lay Sermons” p. 43.)



that unlocked the stores of a whole new world of ethical thought, in the shape of the philosophy, the history, and the poetry contained in Greek and Roman literature. How assiduously those literatures were studied, how they leavened the whole thought of Europe, and mightily contributed to disperse the intellectual darkness and break the bonds of the spiritual despotism of the mediæval Church, we all know. Classical philosophy, history, poetry, and art, nourished the European mind, and were almost the sole foundation of its culture, through all the period during which the Latin and Teutonic races of Western Europe were slowly elaborating languages and literatures of their own. They were thus of necessity the main instrument of culture of the schools during the period when, save the obsolete scholastic philosophy, no other instrument was forthcoming; and I do not think it possible to overrate the debt which Western Europe owes to them. But gradually their educating influence has been absorbed, and in great measure exhausted, while partially, but by no means wholly, out of the nutriment they furnished have sprung the national languages and literatures which, as more and not less powerful educating instrumentalities, are to supersede them. It is to ignore the vast progress of the human mind since the days of Erasmus to try any longer to make classical learning stand in the same relation to the modern student that it stood in to Erasmus: and Erasmus, if he were alive to-day, would be the first to abandon the dead pedantries of the past for the fountains of new thought he would see flowing all round him.

When I say, then, that I think the languages and literatures of Greece and Rome are soon to be abandoned, as the sole or main instruments of that side of liberal culture which I have preferred to call ethical rather than literary, it is not that I do not fully recognize their value and beauty, or the vast service they have done in emancipating and training the mind of Western Europe: it is not that I do not recognize their value as among the specialties of liberal culture now. It is only as the sole or chief instruments of literary school training that I believe them to be superseded. So far from believing that they will be abandoned, I believe they will be more diligently and successfully studied in the future, when they will be left as a specialty in the hands of that small number of students who, at any time, in this modern world of ours, will of their own free choice<sup>1</sup> pursue them. As a

<sup>1</sup> The advocates of the classical theory sometimes point triumphantly to the number of students who, in colleges where the elective system prevails, freely, as they say, elect the classics; but it should be remembered that at present their whole previous school training has been by compulsion classical. Of science they are absolutely ignorant; and it is not strange that they should prefer to go on in studies whose elementary difficulties they have partially overcome, rather than engage in a belated encounter with new difficulties, of a sort for which their minds have been by their very previous training unfitted. The present system at some of our colleges of giving an election between science and literature, after admission, and no similar election in regard to preparatory studies, seems to me to be the very *reductio ad absurdum* of the grindstone-theory.

specialty for the few, classical studies still have a future before them, and we can ill afford to lose the elevating and refining influence exercised by their real votaries on those who do not directly pursue them; but as the main instruments of liberal culture their day seems to me to be nearly over.

In England, the very stronghold of the classical theory, classical study seems to be declining, in spite of, or rather through, the very means taken for keeping it alive. "I fear," says the late Earl of Derby, in the preface to his translation of the Iliad, "that the taste for and appreciation of classical literature are greatly on the decline." "The study of classical literature is probably on the decline," says Matthew Arnold, in his essay on translating Homer. "I cannot help thinking," says Mr. Sidgwick, of Cambridge, "that classical literature, in spite of its enormous prestige, has very little attraction for the mass even of cultivated persons at the present day. I wish statistics could be obtained of the amount of Latin and Greek read in any year, except for professional purposes, even by those who have gone through a complete classical curriculum. From the information that I have been able privately to obtain, I incline to think that such statistics, when compared with the fervent admiration with which we all speak of the classics, upon every opportunity, would be found rather startling.<sup>1</sup> And the truth is that the classical system of liberal education in England maintains its place, so far as it does maintain it, solely from the fact of its being a strictly protected system, through the enormous pecuniary prizes to which it is the sole means of access."<sup>2</sup>

Our own attempts to establish a liberal education seem to me to have thus far proved little less than abortive, because, following as we have in the steps of the mother-country, we cannot bring ourselves to abandon the old shadow for the new substance. For classical study has really dwindled into a shadow. Once it did mean the study of philosophy, of ethics, politics, history, poetry; now, for ninety-nine in a hundred of its students, it means none of these, but the mere dry study of grammar. The scholars of the Renaissance read their Plato in the original, and compassed sea and land to find a teacher who could unlock for them his treasure-house, but it was the treasure-house of his *thought*, not his grammar. The

<sup>1</sup> "Essays on a Liberal Education, ed. Farrar," p. 106.

<sup>2</sup> "The prizes proposed," says Dr. Donaldson ("Classical Scholarship and Classical Learning," p. 154), "are of enormous value. It is estimated that the first place in either Tripos (classics or mathematics) is worth, in present value and contingent advantages, about £10,000. . . . In classics, the majority of successful candidates for high honors have been under tuition in Greek and Latin for at least ten years."

The number of college fellowships at Oxford is somewhat over 300, and their average value £300 per annum. There are 400 scholarships, of an average value of £80, tenable for five years. The incomes of nineteen heads of houses are estimated at £23,000 a year.—(Heywood, in *Social Science Transactions* for 1871.) The sole access to all these pecuniary prizes has heretofore been through classical study.

scholars of the Revival, without Shakespeare or Milton, *had* to master Homer and Æschylus, or go without poetry altogether. With no wealth of modern literature, such as lies all round us, they were perforce classical students in order to be scholars. We cannot put back the wheels of time, and reproduce their circumstances. The mind of the generation refuses to be bound within antiquated limits: it will seek the new world of thought which lies before it. Try, therefore, to make classical scholars now of all liberally-educated boys, and you make nine-tenths of them into dunces or pedants. How many of the regiments of young men of this generation who have *gone through*, as it is well called, our older colleges, are real classical scholars? But the liberally-educated men of the times of the revival of learning were *real* classical scholars.

The Rev. Mark Pattison, Rector of Lincoln College, gives the following account of the present state of classical study even at Oxford: "We must not close our eyes to the fact that the honor-students" (that is to say, the students who have any expectation of winning the pecuniary prizes) "are the only students who are undergoing any educational process which it can be considered as the function of a university either to impart or to exact; the only students who are at all within the scope of the scientific apparatus and arrangements of an academical body. This class of students cannot be estimated at more than thirty per cent. of the whole number frequenting the university. The remaining seventy per cent. not only furnish from among them all the idleness and extravagance which are become a byword throughout the country, but cannot be considered to be even nominally pursuing any course of university studies at all."<sup>1</sup>

If the treasurer of a great manufacturing corporation were to report to his stockholders that, of all the raw material furnished, their machinery was capable of making only thirty per cent. into cloth, and that of a very peculiar and unsalable pattern; that the remaining seventy per cent. was not only not manufactured into any kind of cloth, but was much of it disseminated over the country, in the shape of deadly, poisonous rags, we should think there was something wrong in the machinery of that mill.

Thus it is that, classical education having dwindled into a shadow,<sup>2</sup>

<sup>1</sup> "Suggestions on Academical Organization," p. 230.

<sup>2</sup> "I think it incontestably true," says Prof. Sidgwick, "that for the last fifty years our classical studies (with much to demand our undivided praise) have been too critical and formal; and that we have sometimes been taught, while straining after an accuracy beyond our reach, to value the husk more than the fruit of ancient learning. . . . This, at least, is true, that he who forgets that language is but the sign and vehicle of thought, and while studying the word knows little of the sentiment—who learns the measure, the garb and fashion of ancient song without looking to its living soul or feeling its inspiration, is not one jot better than a traveler in a classic land who sees its crumbling temples, and numbers, with arithmetical precision, their steps and pillars, but thinks not of their beauty, their design, or the living sculptures on their walls, or who

our colleges are looking about for a remedy, and a class of thinkers, just now, as we know, very influential, and looking to the substitution of the study of science as the sole remedy. Gentlemen, I have been long enough attached to a school of science to have been convinced, if I had ever doubted it, that science by itself is no remedy; that as there can never again be a liberal education, or the pretense of one, without the scientific element, so, on the other hand, scientific studies alone can never constitute a liberal education—scientific can never supersede ethical studies as its foundation. What, then, is the true remedy? I think it is evident. It is, along with scientific study, of whose true place I shall have more to say presently, to accept ethical studies in their new form, in the form of modern literatures and modern languages, and with classical studies as the special and subordinate, and not, as heretofore, the main and primary instrument. This is the great change which liberal education is silently undergoing, far more than it is a change from a literary to a scientific basis.

I know of no educational fallacy more common and more mischievous than that of enormously overrating the educating value of the process of acquiring the mere form of foreign languages, whether dead or living; yet it is in this barren study that we waste the precious time that should be employed, from the very beginning of school-life, in acquiring the substance of real knowledge. Languages, other than our own, are the useful, sometimes the necessary tools for acquiring knowledge; in the literatures of other tongues there reside elements of culture not to be found, or not to be found in the same perfection in our own, which may well repay the student who has time and perseverance sufficient really to attain them without too great a sacrifice. But to sacrifice an attainable education in *not* attaining them, what is it but to sow the barren sea-shore, to travel half a journey, to possess one's self of half an instrument useless without the other half. Languages alone are knowledge only to the professed philologist; we sacrifice a real education attainable through an instrument we already possess in the fruitless labor of giving our boys other instruments they will never make use of.

counts the stones in the Appian Way, instead of gazing on the monuments of the 'Eternal City.'"—("Discourse on the Studies of the University of Cambridge," fifth edition, p. 37.)

I find a corroboration of this view of the present state of classical study on this side of the water coming from a quarter where there can be no suspicion of too great leaning toward modern studies. Prof. Tayler Lewis is reported to have expressed himself in a recent pamphlet as follows: "He thinks it undeniable that there is danger that classical studies may be driven from our colleges; and, in looking for a reason for this, he seems to himself to have discovered it in the fact that we nowadays busy the undergraduate too much with grammar and too little with literature. . . . He illustrates his position by a comparison of the school of critical students even so great as Porson and Elmsley with the earlier schools. . . . The one school, admirable as it is, and deep as is our obligation to them, he regards as reading Homer for the sake of knowing Greek; the other as knowing Greek for the sake of reading Homer."—(*New-York Nation*, August 7, 1873.)

I think that we monstrously overrate the educating value of the mere process of learning other languages; but with the mother-tongue the case is altogether different. Here the mastery of form and substance can proceed *pari passu*. The mother-tongue is the only one which can stand to our modern liberal education in the relation in which the classical tongues stood to the scholars of the revival of learning. It might be said that Greek and Latin were mother-tongues to them as scholars, because it was through them alone that they reached the *thoughts* which really educated them. They were not brought up on empty words and barren syntax; they studied no grammars, for grammars were non-existent. Their minds were really nourished on the philosophy of Plato, and Cicero's eloquence, and Homer's poetry, and the lessons not the words they found in Tacitus and Thucydides. Now, when we have a philosophy, a history, a poetry, a law, an ethics, which embody all that is valuable in classical literature, together with all the progress of thought has produced through these later centuries, we not only fail to use them as those older scholars used their older instruments, really and efficiently, but we equally fail in using the older ones. We abandon both to feed our boys on a husk without a kernel. What wonder that our higher education is struck with barrenness?

When, therefore, I propose modern language-study instead of ancient, as a chief instrument of school education, I mean much more than the mere substitution of the study of some modern language as language, for some ancient language as language—German, for instance, instead of Greek, as has sometimes been suggested. This would be the mere semblance of a remedy, for the difficulty consists in the enormous overrating, by what I have called the grindstone-theory, of the educating value of the study of the mere structure and vocabulary of any strange language whatever. It has sometimes been doubted if we can ever really know more than one tongue, and certainly all our deeper mental processes go on in that one we know best. If that is a foreign one, it is because we have lost a mother to gain a step-mother; and a stepmother she will ever remain. What is very certain is, that too many of the recipients of our present education, in seeking to possess themselves of more than one language, end with having none whatever. Neglecting to develop their minds through the instrumentality of their mother-tongue, and never, therefore, really knowing it, they equally fail in providing themselves with any substitute; with Shakspeare's pedants, "they have been at a great feast of languages, and stolen the scraps."

My position, therefore, is that, so far as language-study shall form a part of the elementary discipline of the liberal education of the future, the centre and pivot of it all will hereafter be the scientific study of the mother-tongue. I anticipate something almost like ridicule for this proposition on the part of those—and they are many—who undervalue our native language so far as to believe it to be incapable

of becoming an instrument of disciplinary education. Time would fail me to go into a defense of this proposition. I will only say that I believe that it is precisely the change which the progress of modern philology is bringing about; that it is fitting modern languages, and preëminently our own, to become the instrument of a true mental discipline, so far as language-study can serve as such an instrument. On the one hand it is giving a scientific form to the study of the Teutonic element, and on the other there remains the still needful study of the Latin language—a study which certainly need not lose in force and vitality because it may no longer be pursued as the basis of a superstructure never to be erected, but shall have a definite object and be pursued for a practical end.

But far above and beyond its uses as language-study comes the advantage of the direct and immediate entrance it gives to those regions of thought in which the higher mental discipline really lies. Through the direct road of the real study of the mother-tongue, and that rhetorical and, above all, that real logical study which accompanies and forms a part of it, can the study of what we vaguely denominate literature, and that which we are beginning still more vaguely to denominate social science, but which yet, between them, contain the substance of all we most need to know of man as distinct from Nature, be made real portions of general knowledge—be transferred from being a possession in the hands of the few, to be reached only by an abstruse and difficult preparatory training, secrets unlocked by a key out of reach of the hands of the many, to being a part of the general inheritance of all men. For, to be so, they must be made primary and not secondary; in other words, that time and strength must be devoted to a fruitful study of modern thought and modern literature, which have heretofore been wasted in school and college on the futile attempt to master ancient thought and ancient literature. The rudiments of all those studies must be reckoned as the most valuable of all the elements of general elementary training, which, in their higher departments, and after liberal culture, diverging in various directions, form the substance of professional knowledge, both that of those professions now reckoned, and of all those hereafter to be reckoned liberal. For, what should liberal education be but the preparatory general stage for that work of life which all honest callings and professions carry on in diverse directions afterward? What is a professional education but a liberal education taking a special direction?

Can it now be said, with any truth, that our nominally-educated young men go out into the world equipped with that general knowledge of the sciences of law and government, and political economy, with that knowledge of ethics and philosophy, with that acquaintance with modern history and of the condition of the world they live in, and with that real taste for modern literature, which should form the equipments of every man calling himself educated? We



shall have to give a negative answer, just so long as we do not look upon all these as the truly disciplinary studies, and the elements of all these as the true elementary studies, the very school-studies fitted, above all others, for maturing the youthful mind, and filling it with true wisdom. So long as we insist upon approaching them through the operose and roundabout method of dead-language studies, school-days will flee away, and the object will *not* be accomplished. The great vice of our education, as has been well said, is its indirectness.

Combining the ideas which I have thus presented—1. That the study of foreign languages as languages, whether dead or living, holds a place in our present education-philosophy quite out of proportion to its real value and importance, and that it is the discipline of philosophy which we are indirectly aiming at, behind and through the discipline of language; 2. That it is through one tongue and not many that that discipline can best be imparted, inasmuch as that is the only one that can or will ever, by the majority of men, be really mastered; and, 3. That now, for the first time, there is the possibility, through the progress of modern linguistic science, of a scientific and systematic study of the mother-tongue—I arrive at the conclusion that we are presently to have, as a substitute for the exclusive or almost exclusive use of classical languages and literatures, as the main disciplinary element in liberal education, a systematic study of the English language and a recognition of its literature as primary, not secondary. And surely it is a strange phenomenon, if it be true, as a foreign scholar has recently maintained,<sup>1</sup> that the sovereignty of the world is hereafter to belong to the English language; and if it be true, as I think may well be maintained, that with this conquering language we possess the world's foremost literature, it is a strange phenomenon that we think them so little worthy of systematic study, give them a place so subordinate as instruments of our own liberal culture, that to-day we must go to the Germans for a good English grammar; to the French for the best, if a very defective, history of our literature. To my mind, no more striking illustration could be given of our want of a true education-philosophy.

How has it happened that we still lack such a philosophy? The answer to that question brings me to my next point, and the third new ingredient in the liberal education of the future, the element contributed by republicanism. I have said that the science of education was still in its infancy; I believe that it is only as a part of republican institutions that it can reach maturity. For the only true liberal education is the education of man as man; the only truly liberal system is that which can be applied to a whole nation, and such a system is only possible as a part of republican institutions. And, when we consider how short a time we have been living under them, and how crude and imperfect they still are, it is not strange that they have not yet pro-

<sup>1</sup> De Candolle.

duced what will be rather one of their maturest than one of their earliest fruits, a truly liberal education-system.

The history of our errors in regard to liberal education is a very plain one. They are the legacy of the mother-country from which we came, a mother-country which is just beginning to correct her own errors, even by the light of our limited experience. I wish to point out and emphasize the fact that republicanism revolutionizes our very conception of liberal education. All forms of liberal education of the past, and preëminently the one we borrowed from England, were forms of exclusive class-education. The idea of caste was involved in their very conception, to such a degree that the phrase, the liberal education of the people, was a contradiction in terms. The antithesis was, popular *versus* liberal education. There was the illiberal or servile education of the masses, designed to fit them for the humble station in which it had pleased Providence to place them, and to content them therewith; there was the liberal education of the exclusive learned professions, and the exclusive aristocratic class, which was liberal by virtue of its being the education of the rulers and not the ruled.<sup>1</sup> Now, republicanism, by converting the people into rulers, transfers to them the claim to a liberal education, which shall be universal. A transfer of the power alone, without a transfer of the privilege and the opportunity necessary to prepare for the exercise of it, cannot but be disastrous. If republicanism is to remain republicanism, and not degenerate into oligarchy or plutocracy, or end in anarchy, there must be one homogeneous education-system for all, and that one the highest attainable. The line of demarcation between liberal and illiberal must be obliterated, and what cannot be called liberal will be seen to be no education at all, but only a miserable counterfeit, by which privileged classes strive to perpetuate obsolete distinctions and indefensible abuses. For a republic, there can be but one system, and one set of schools; its education, begun on the lowest benches of its national primary schools, will one day be completed in the halls of its national universities. There will be no question as to the relative dignity of protected and unprotected professions, or callings, or classes, but all will

<sup>3</sup> "Religious teaching, from Episcopal charges down to the lessons of the Sunday-school, was, for a long time, as most of us can remember, in the habit of assuming that true religion was identified with government by the upper classes. . . . We may safely say that neither from Catholic nor from Protestant theology could we extract any formal witness in favor of the acquisition of political power by the humbler and more numerous classes. . . . But the lower classes have not been content to stay in their places. Whatever the Church has taught, democracy has advanced irresistibly. Privilege after privilege has been wrenched out of the grasp of the favored classes, power has gradually descended, by the steps of the social stairs, until it has joined hands with the last class at the bottom. At the present time, it is a confessed fact, whether we like it or not, that the working-class, if it had peculiar interests, and were unanimously resolved to promote them, might dictate the policy of the empire."—(Rev. J. Llwellyn Davies, "Theology and Morality," pp. 10, 12.)



be reckoned liberal which train and educate the faculties of man as man.<sup>1</sup>

Now, the only conception of a liberal education that will satisfy these new conditions, the only conception of an education capable of becoming national and universal, at the same time that it is liberal, is that of a training of the national mind through the mother-tongue as the chief, and other tongues as the subordinate instruments, in the elements of all those branches of knowledge which, used in their rudiments as elements of general training, will develop, in their higher stages, into the objects of professional pursuits. Is there any other distinction than this between general and professional? In the infancy of knowledge, all callings, trades, and professions, are mysteries, whose secrets are carefully guarded from the uninitiated. Every mechanic belongs to his trade-guild, and has his trade-secrets. When Philip of Burgundy destroyed the little town of Dinant, in the Low Countries, the art of making copper vessels became, for the time being, a lost art. With the progress of general intelligence mystery falls away from simpler occupations, but still attaches to

<sup>1</sup> Nothing seems to me more thoroughly unrepubli- can and illiberal than the ground taken, by some who profess to be preëminently the advocates of liberal learning, against the promotion of higher education by grants from the state. Let the state promote the advancement of elementary education, they say, but for higher institutions to handle government moneys is only to touch pitch, and therewith be defiled. The distinction represents a remnant of aristocratic feeling, and springs from the idea that it is the duty of the educated, as a higher class, to take a paternal care for the masses; not the duty of the people, as a self-governing community, to give *itself* a liberal education. One cannot well see a higher function to be performed by the people, acting as a body, than to promote, by public action, its own higher education. If a line is to be drawn, beyond which its action should not reach, where shall it be drawn? Shall the people be allowed to promote the teaching of the three R's, and the four rules of arithmetic, but be forbidden to meddle with any thing beyond them? And in whose hands is the higher education to remain, in a country which has no established church? Is its progress forever to remain at the fitful mercy of an unenlightened and unsystematic private charity? The question as to the right means and methods of governmental action is undoubtedly a grave one, but no educational waste of state or national resources is ever likely to equal the waste arising from the capricious absurdity of private endowments. We have, indeed, of late, been startled by revelations of government corruption, but they have but a poor notion of the capacities of republicanism who are scared by them into that meanest of all political theories, the doctrine that the sole function of a government is merely to enact the part of head constable.

A far juster view is that propounded by one of the best of England's teachers. "As the condition of social, and, to some extent, political independence," says the Rev. Mark Pattison, "is necessary to prevent material interests from stifling and absorbing studies, so the condition of sympathy with the general mind is necessary both to sustain the required activity and to make the university a proper seminary for the education of the national youth. The nation does not hire a number of learned men to teach its children: it itself educates them, through an organ into which its own best intellect, its scientific genius, is regularly drafted. This education is, in short, nothing but the free action of life and society, localized, economized, and brought to bear."—"Oxford Essays for 1855," p. 259.)

what are called the learned professions. The layman has nothing to do with the study of the science of theology: that must be expounded to him by his priest. The layman has nothing to do with the science of medicine: he must be cured, or, more probably, killed, *secundum artem*, by his physician. The layman has nothing to do with the science of the law: it is his business to get into lawsuits, and it is the lawyer's secret how to extricate him. But these superstitions, the relics of an age of popular ignorance, are in their turn disappearing, as just ideas of what constitutes real knowledge begin to penetrate the minds of the whole people. It is seen that, so far from being mysterious, such knowledge is the very substance and material of sound education for all men; and the layman will no longer allow himself to be led blindfold by priest, or lawyer, or physician, for there is no longer any magical sacredness in their callings. And thus it comes about that a knowledge of physiology, which will help save the patient from any need of a physician; a knowledge of law, that shall obviate the necessity for lawsuits; a knowledge of political science and history worthy of men who have become their own rulers; a knowledge of political economy, that shall raise the honorable calling of the merchant to the dignity of a liberal profession; a knowledge of theology that shall save us the degrading spectacle of the unchristian quarrels of bigoted and superstitious sects—are reckoned more and more to be essential elements in *all* education. It is only on sound general knowledge, disseminated through the whole people by a liberal education of the whole people, that we shall ever build up professions, in regard to which we are not forced to entertain a doubt as to whether they are not on the whole more of a curse to us than a blessing.<sup>1</sup> And an education of this sort must be begun in the primary school, must have for its instrument the mother-tongue. It cannot be based on the study of Greek particles, or any amount of skill, either in the reading or the manufacture of Latin verses.

It is sometimes said that we, who have received this liberal education we decry, are ungrateful in thus decrying it, and unconscious of, and insensible to, all the benefits we derive from it. I am conscious of no ingratitude in agreeing with an eminent Scotchman who discusses these subjects, when he says, in speaking of knowledge and studies such as I have been enumerating: "I am sure no one seriously applies himself to such studies without wishing that he had given to them many hours in his youth which he fooled away, in obedience to his 'pastors

<sup>1</sup> "We need diffused knowledge in the community to sustain soundness of public opinion, and prevent the perversion of separate sciences into black arts and professional secrets."—(*Prof. Newman, on the Relations of Free Knowledge to Modern Sentiments.*)

The affirmation of Prof. Seeley is destined, I fear, to find an illustration in the experience of this country, "that a people will never have a supply of competent politicians until political science . . . is made a prominent part of the higher education."—*Inaugural Address on the Teaching of Politics.*

and masters,' in learning what he has now forgotten, and to recall which he would not now take the trouble to raise his little finger." <sup>1</sup> I was the docile and diligent receiver of such training as, in my youth, a "classical school" and our oldest New-England college had to give, and surely it is from no vanity that I say that I was also a recipient of their honors; and it is from the melancholy feeling that my formal education was so barren and empty when looked at from the standpoint of real life, and real thought, and real mental training, that I am so earnest an advocate of changes that I believe will give to future generations the reality instead of the pretense of an education.

I come now to the study of Physical Science, as from this time forward destined to play a wholly new part in our system of liberal education. Nowhere, save in that astonishing document, the Syllabus of his holiness Pope Pius IX., can any education-philosophy be found so benighted as not to recognize its value and importance. Yet I am far from believing that its true place, as a factor in the new education, has yet been determined. While, on the one hand, among the old high-and-dry advocates of the grindstone-system, certain merits and a subordinate place are beginning to be grudgingly allowed it, we are in danger, on the other hand, in this new country of ours, whose vast material resources are waiting for development through its instrumentality, rather of overrating than underrating its purely educational function. It is not as an economical instrument for the development of material wealth that I have here to deal with it, though that is a very important aspect, but considered as a factor in a system of education, and, as such, I claim for it no monopoly, but only a place as the indispensable complement to those ethical and linguistic studies which have heretofore monopolized the title of a liberal education, and which, from the absence of science from that form of education, have been reduced to their present effete and impotent condition. It is to the incorporation into it of the study of science that we are to look as the source of new life-blood.

You will not expect me to attempt to deal here with the great subject which forever occupies the minds of speculative thinkers, and never more than at the present moment—the true relations of the world of matter and the world of mind. That is too large a subject to be dealt with, though upon right views regarding it will greatly depend the correctness even of our educational theories. I will only say, that though I am as far as possible from being an adherent of any form of materialism, yet I believe that physical science is destined to be the great instrument of these modern days to give new forms to our philosophy and our theology—to give new forms to the same everlasting problems, but not to give us new philosophy or new theology. It will but cast old truths in new moulds, while it explodes old super-

<sup>1</sup> Mountstuart, E. Grant Duff, Inaugural Address as Rector of the University of Aberdeen, p. 22.

stitutions by adding new truths to the old ones. Our conservatives may spare their anxieties. Not a truth the world gains is ever lost again; but they who, blindly believing they have all truth, oppose the new form which science is giving to all knowledge, will soon find themselves side by side with those old Dunsemen who could not believe in the last revival of learning.<sup>1</sup>

Now, if the study of physical science is to play a vastly more important part than it has hitherto done in all future schemes of liberal education, the first and most obvious consideration is that room must be found for it. Bearing in mind, as we must constantly do, that the word education stands for a strictly limited quantity, a limited amount of time, a definite amount of mental effort, if that time and mental effort have been wholly absorbed in one set of studies, it is very obvious that these must undergo modification and curtailment in order to make room for another set. And yet no error is at present more common or more disastrous than the attempt to introduce the new, without any disturbance of the older studies. Either the older curriculum did not absorb, as it professed to do, the whole of the student's mental energies, and was not therefore a complete education, or its requisitions must be diminished to make room for another set of solid, important, and disciplinary studies; or else it must be maintained that the new studies are not solid, important, and disciplinary, but only fitted to be the amusement of idle hours, and the lighter tasks with which gaps and intervals may be filled between the more solid, older ones. That this latter is really the view of the more thorough-going adherents of the classical system is pretty obvious. Thus the Rev. S. Hawtrey, one of the masters of Eton, says, in a recently-printed lecture: "It is for the masses that I fear, when I hear the cry that boys should be freed from the *severer* labor of studying language if it is distasteful, and therefore it is said unprofitable, and should learn, instead, something about the wonders which science has achieved in the present century."<sup>2</sup> It is very obvious that a writer who speaks

<sup>1</sup> "There is no reason for thinking that philosophy, which is only a just and perfect judgment on the bearings and relations of knowledge, should not be as generally attainable as a wise judgment in practical matters is. And should our universities, ceasing to be schools of grammar and mathematics, resume their proper functions, it will be found that a far larger proportion of minds than we now suspect are capable of arriving at this stage of progress. For, be it again repeated, it is not a knowledge, but a discipline that is required; not science, but the scientific habit; not erudition, but scholarship. And those who have not leisure to amass stores of knowledge to master in detail the facts of science, may yet acquire the power of scientific insight, if opportunity is afforded them. It is the want of this discernment and the absence of the proper cultivation of it which produce that deluge of crude speculation and vague mysticism which pervades the philosophical and religious literature of the day, and which is sometimes wrongly ascribed to the importation of philosophy itself and its recent unreasonable intrusion on our practical good sense. The business of the highest education is not to check, but to regulate this movement; not to prohibit speculation, but to supply the discipline which alone can safely wield it."—(Pattison, in "Oxford Essays for 1855," p. 258.)

<sup>2</sup> "A Narrative-Essay on a Liberal Education," p. 29.

of the severer study of language has very little comprehension of the true nature of the study of science, or else, like the public orator of Cambridge, in his "tonic" theory, confounds together the ideas of severity and distastefulness. And Mr. Hawtrey's very childish conceptions in regard to the teaching of science are further exemplified when he goes on to ask: "Would there not be great danger of boys becoming less vigorous-minded than they are? . . . Will their becoming acquainted with a string of scientific results stand them instead of the mental training they now get?"

Thus we see that the highest conception a master of Eton has of the study of science is that it is "becoming acquainted with a string of scientific results." I need not pause before this audience to refute such a notion. If the study of modern science did not call for the exercise of all the highest faculties of man; if it did not give an exercise such as no other study gives to his reasoning as well as his observing powers; if without it the very study of language itself did not become empty and barren; if a knowledge of it were not necessary to the solution of all the profoundest philosophical problems with which the mind of man in these generations is occupied—then, indeed, a question might be raised as to the propriety of its introduction into the curriculum of liberal study. But if it is this, and more than all this, then it claims more than a subordinate place; it is no toy for idle hours, no subject to fill up gaps and intervals of time. It claims a right to no less than a full half of all available time and power; of time for training the student's senses—all left by our older training in worse than Egyptian darkness—of power to be employed in training the reasoning faculties, by processes as rigorous as any the older studies can boast of. Nothing less than this will satisfy the demands of science as an element in modern liberal education.

I have already indicated what seems to me to be the only way by which room can be found for the real introduction of science into our scheme of studies. By removing Greek wholly from the list of general studies to that list of specialties which make up our completed conception of the higher education, after it diverges in different directions; by relegating Latin to a subordinate instead of a primary place in language-training, we shall find room to place science on an equal footing with literature as an instrument of general liberal culture; and I see no other way. And this scheme will have this further advantage, that, for all who carry their education beyond its rudimentary stages, it will afford ample time and opportunity for the *real* mastery of at least two of the leading modern languages besides our own: for French, the modern daughter of the Latin—for German, a kindred Teutonic dialect closely related to our own. I am aware that such a scheme for the teaching of modern languages, including our own, so systematically and scientifically, as that the mental discipline derived from it shall not be inferior to that derived from the teaching

of the classics, implies an adaptation of the results of modern philology to the purposes of elementary instruction such as has hardly yet been realized; implies a body of teachers of modern linguistic science such as hardly yet exist—teachers whose instruction shall not be inferior in philosophic breadth and thoroughness to the very best of classical teaching. If we have few such books or teachers yet, there are indications on every hand that we very soon shall have them in the greatest abundance, and that modern language-teaching and English language-teaching are very soon to be relieved of the reproach of empiricism which has heretofore prevented them from taking the leading place which, as educating instrumentalities, rightfully belongs to them.

And, finally, time will also be gained by utilizing the at present barren and empty study of mathematics. If there is any thing more preposterous than the abuse of grammar, in our present grindstone-system, it is the abuse of mathematical study. Rightly viewed, the mathematics are the key to scientific, as language is the key to ethical study. At present, both are used as mental tread-mills, unprofitable mental gymnastics, keys to unlock empty chambers never destined to be filled; for their sole value is thought to lie in the mental exercise they give. Robbed thus of all living connection with other knowledge, they become the most disgusting, and therefore the most valueless, of mental exercise. Put into vital connection from the very outset with those great sciences, of whose laws they are only the symbolic language, the mathematics spring into life. By themselves, they are to most minds a series of barren puzzles, hardly rising in dignity or educational value above the game of chess, and so remote from all those paths in which the human mind naturally travels, that it is only one peculiarly-constituted mind in ten thousand that, in their abstract form, can pursue them with either pleasure or profit.<sup>1</sup> Looked at as the language of the laws which govern the world of matter, and used as the instruments to unlock so many of its secrets, they lose their disgustfulness, and become a necessary, if a narrow and partial instru-

<sup>1</sup> Since writing the above, I have met with an unexpected corroboration of this view in the writings of an eminent mathematician. "I am not likely," says Mr. Todhunter, the distinguished mathematical teacher of English Cambridge, "to underrate the special ability which is thus cherished (by competitive examinations), but I cannot feel that I esteem it so highly as the practice of the university really suggests. It seems to me at least partially to resemble the chess-playing power which we find marvelously developed in some persons. The feats which we see or know to be performed by adepts at this game are very striking, but the utility of them may be doubted, whether we regard the chess-player as an end to himself or to his country."—"The Conflict of Studies," p. 19.) What the teaching of the higher mathematics appears to have become at Cambridge, that the teaching of their elements, divorced from their natural connection with the teaching of physical science, becomes in our schools and colleges.

On the fallacy that it was the mathematical studies at Cambridge of certain eminent graduates of Cambridge that was the cause of their eminence, and for some wholesome common-sense, in regard to the general subject, see a recently-published pamphlet, "The Mathematical Tripos," by the Rev. H. A. Morgan, Fellow of Jesus College, Cambridge.



ment of training—one which performs certain disciplinary functions which no other instrument can perform so well; but it is only live mathematics, not dead mathematics, mathematical in vital connection with physical science, not prematurely thrust as an ugly skeleton alone upon the youthful mind, upon the pretense that its sole object is their mental discipline. And, on the other hand, it is only for the study of physical science, pursued by vigorous scientific methods, and in rigorous, logical, and mathematical ways, that we can claim for it a place as a disciplinary, that is, a real study. As the mere becoming acquainted with a string of scientific results, it may well be left to the contempt of the Rev. Mr. Hawtrey.

But the chief influence of modern science upon liberal education will be its ethical influence. Its discoveries are transforming man's conception of the earth he lives on, and of his history and his work upon it. Before man acquires the control of matter, through ascertainment of the laws that govern it, his life on earth is poor, narrow, and full of hardship, and his earthly relations full of pain. So long as that state continues, life on earth must seem to him a small matter, and its opportunities for growth not much worth considering; it is only here and there that a philosopher in his closet attains to some realization of the capacities that lie hidden in it. War and savage occupations consume the days of the mass of men, and no culture is possible save the perverted culture of the cloister. But the advent of physical science means the emancipation of the masses into the privileges of intellectual life. From a battle-ground, the earth is transformed into a school-room, written all over with hieroglyphics, no longer mysterious, but to which mankind have found the key: and, with the right use of the secrets thus unfolded, will come to the mass of men that accession of material wealth which will give the leisure and opportunities that have heretofore been the monopoly of privileged classes.

It is not wonderful that men, at first, are carried away with the contemplation of its lower uses, even sometimes to the making them the sole end of education. It is but a reaction from the opposite extreme, only a dazzling of eyes with a flood of new light. Presently we shall look about us, and find the old relations of things not greatly altered. Matter is not going to supplant mind because we are learning so much more about it; whether we understand or do not understand the laws that govern it, matter remains the servant of mind, to educate it and do its bidding. The higher uses of science will still be spiritual uses. It has not come into the world merely to carry us faster through space, merely that we may sleep more softly and eat and drink more luxuriously, nor will education become the mere teaching how to do these things. It is with the spiritual educating function alone that we have to deal when we consider it as an element in liberal education.

And thus one great result of the new form into which modern science is casting all our conceptions of education will be a vastly higher estimate of the educating value of those pursuits in life which are concerned with material things, and a distinct recognition of them as included among the liberal professions. It is interesting to observe how the list of liberal professions enlarges with the advance of civilization. At first the priest is the divinely-appointed monopolist of all higher knowledge; by degrees he is joined by the lawyer, as the interpreter still of a divinely-established code; it is much later and only after a certain amount of progress has been made in physical knowledge that the importance of his function raises the physician's art to the dignity of a liberal profession; and that more at first through a superstitious belief in the power of his spells and his magic than from respect to the small reality of his science. Now that science has so far entered into other callings as to make them worthy fields for the exercise of the highest faculties, all those pursuits which have for their aim the improvement of man's earthly condition will take their due rank in the list of liberal professions, and the chemist, the engineer, the architect, and the merchant, will have their appropriate liberal educations as much as this clergyman, the lawyer, or the physician. It may safely be affirmed that that view of earthly life of mediæval ascetics which has left its traces so deeply imprinted in much of our sectarian theology is fast vanishing like an ugly dream forever. The intellectual and moral aspect of material pursuits is fast gaining, through the significance given to them by modern science, a predominance over their mere material aspect. The worker in material things is more and more, as the days go by, compelled to be an intellectual being even in order to be a worker, and it is because the study of and working in material things now give scope for the energies of great intellects, that they more and more absorb them. Whoever continues to believe in the antithesis between matter and spirit, and insists upon looking on the world of material things as of necessity the world of the devil, must see in this tendency only disaster to all our higher interests; but whoever sees that it is the true function of modern science to spiritualize material things by enabling us to put them to higher uses, will see in science not the great antagonist but the great hope of the religion and the philosophy of the future.<sup>1</sup>

The advocates of the classical theory are never weary of reproaching their opponents with opinions which, as they say, degrade the dignity of true learning, by making it subservient to mere utilitarian

<sup>1</sup> The spirit of the older education is well represented in the following extract from a work of that learned and arrogant pedant, the late Dr. Donaldson. He says: "If, then, the education of the whole community is so dependent on that of the *upper classes*, and if these owe their normal influence to the circumstances which enable them to escape the trammels of material interests, it must follow that the liberal education which is the peculiar attribute of the highest order ought to consist in the literature which humanizes and generalizes our views, and not in the science which provides for the increase of opulence



aims. If to try by knowledge to make this world a better place to live in, and to teach men how to make the highest and best use of it be utilitarianism, then I make bold to say that any knowledge that cannot make good its claim to such usefulness is worse than utilitarian, for it is useless knowledge. The charge that is meant to be brought is this, that none but the advocates of classical learning have or can have the higher ends of life in view in planning schemes of education; that all other systems look solely to the stomach or the pocket. I do not know whether such charges are not too hackneyed to waste words on; certainly I can conceive of no lower form of utilitarian abuse of education than the pursuit of fellowships by the cramming of Greek and mathematics for the competitive examinations of an English university. On the other hand, the truly liberal learning of England is to be found more than anywhere else at this moment with that noble band of students of science who are virtually excluded from all such preferments.<sup>1</sup> It is not a difference in studies that constitutes them liberal or illiberal; it is a difference in the spirit in which all studies may be pursued. The study of chemistry and the study of Greek particles may be equally base or equally noble, according as they are pursued worthily or unworthily, with a selfish eye to the loaves and fishes, or with an aim at the higher rewards of true culture, and the higher advancement of man's estate. But I think we may well leave aside this stupid charge of utilitarianism. It comes nowadays only from those benighted pedants who are wholly ignorant of the true spirit of modern science.

I have left myself no room, even if I were competent, to speak of the last ingredient in any just scheme of modern liberal education—the study of art, æsthetic culture. I fear there will be abundance of time to develop that side of the question in this country before it is in any

and comfort. The higher training of our youth must not be that of a polytechnic school. We want such institutions, no doubt, for we need observers and surveyors, engineers and artillerymen to do the work, which can best be performed by such *intelligent automatons*.” —(“Classical Scholarship and Classical Learning,” p. 90.)

<sup>1</sup> “I believe there can be no doubt that the foreigner, who should wish to become acquainted with the scientific or the literary activity of modern England, would simply lose his time and his pains if he visited our universities with that object. . . . England can show now, as she has been able to show in every generation since civilization spread over the West, individual men who hold their own against the world, and keep alive the old tradition of her intellectual eminence. But in the majority of cases these men are what they are in virtue of their native intellectual force, and of a strength of character which will not recognize impediments. They are not trained in the courts of the temple of science, but storm the walls of that edifice in all sorts of irregular ways, and with much loss of time and power, in order to obtain their legitimate positions. Our universities not only do not encourage such men, do not offer them positions in which it should be their highest duty to do thoroughly that which they are most capable of doing; but, as far as possible, university training shuts out of the minds of those among them who are subjected to it the prospect that there is any thing in the world for which they are specially fitted.”—(Huxley, “Lay Sermons,” p. 55.)

danger of becoming a practical one. Yet, in the shape of elementary drawing, the rudiments of art are beginning to take their proper place in our schools as a necessary and indispensable element of all real education, and the art galleries and the foreign musicians of a few of our older cities are beginning to exert their influence, if a slight one, in introducing higher ideas of the importance of art into our new country. They will have but a limited influence, however, till the study of the fine arts takes its proper place among us as a necessary element in every conception of true education.

There is one form of art-study, and that, perhaps, the highest, which is open to all, even to the humblest student, and the most elementary school, and that is, the study of poetry. It is a prime element in any conception of a liberal education, which shall take as its chief instrument of language-training the mother-tongue, that the real study of English poetry will take the place of the pretended study of classical poetry. When that time comes, we may expect to see the great poets of our native tongue exerting the same influence in the culture and training of our children that Homer and Æschylus really exercised over that of the Greeks. We shall not know what that influence is capable of becoming till we have a *real* study of English, in place of a sham study of classical literature. The great Greek philosopher says that poetry is truer than history. Sure I am that we shall one day come to see that in neglecting to train and cultivate the imagination, we are neglecting the most powerful of all the faculties.

Ladies and gentlemen, I have thus given you, very feebly and imperfectly, an outline of a scheme of liberal education, applicable to a whole free people, which shall use that people's own language on the one hand, and the great instrument of modern science on the other, as its chief disciplinary instruments, in lieu of the obsolescent scheme for a liberal class education, based upon the study of dead languages as its chief educating instrument. As a means for realizing that scheme for the liberal education of the whole people, I believe that we must sooner or later have in this our republic one homogeneous system of free schools, from the lowest to the highest. The first step of that education will be taken from the benches of the primary school, its last lessons learned in the lecture-rooms and laboratories of universities, free from all trammels of sectarian narrowness or class distinctions. It will be from first to last a homogeneous, logically compacted, consistent training in all available knowledge, to all attainable wisdom, free to all men and all women to pursue to the extent the faculties God has endowed them with will carry them. It is a Utopian vision, you will say, this of popular liberal education. Say rather it is the necessary safeguard and supplement of free institutions; to despair of it is to despair of the republic.

## THE GROWTH OF SALMON.

BY C. E. FRYER.

SINCE the time of Magna Charta it has been an object, directly or indirectly, on the part of the Legislature, to protect the supplies of salmon with which our rivers used to be so abundantly stocked: but, notwithstanding the laws which have at various times been enacted, this fish gradually became scarcer till, in 1861, all the old laws were repealed, and fresh and more stringent regulations made for protecting and increasing our salmon-supplies. In addition to the fostering care which is bestowed, under the Salmon Fishery Acts of 1861 and 1865, on the fish in the rivers, means have been adopted to artificially rear salmon, so as to increase their numbers more rapidly than could be done in the ordinary course of Nature. Mr. Frank Buckland has been the pioneer of this system of artificial breeding of salmon and trout, and the experiments and operations which have been carried on during the last few years have thrown great light on the hitherto unknown habits of this "king of fish."

Any one who looks into the fishmongers' shops just now can see what a clean, fresh-run salmon, ready for cooking, is like—a silvery, plump creature, whose "lines" are made for speed in water, and whose graceful curves give the completest idea of vigor and strength in stemming a rapid current of water.

But very few people, probably, know what sort of an appearance this beautiful fish presents in its infancy. Hidden away during that period in the upper waters of our salmon rivers, and ultimately in the depths of the sea, it is lost to sight till it grows large enough to be taken by the salmon-nets; and, until lately, very little was known of its natural history, or of its habits, though the experience of the last few years has revealed many interesting facts concerning the development of this fish, through the egg, fry, smolt, and grilse stages, till it becomes a full-grown salmon.

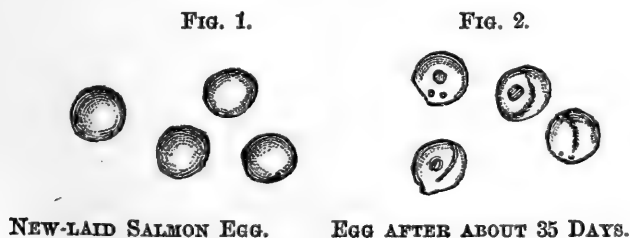
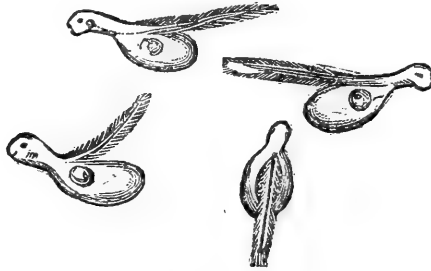

Fig. 1, represents the egg—natural size—of a salmon just laid. Each female salmon carries, on an average, 800 to 900 of such eggs to every pound of her weight. They are generally of a pinky opal color, elastic to the touch, covered with a soft, horny membrane, with a mi-

nute opening through which a particle of the spawn—the soft roe—of the male fish enters, and the egg is fertilized. From this moment the young fish gradually develops, under the influence of the cold running water. At the end of about thirty-five days—more or less, according to the temperature, which should be about  $40^{\circ}$ —two little black specks can be seen, as at Fig. 2, which are the eyes of the embryo fish; the vertebræ may be discerned in the form of a faint red line, and a small red globule, which shortly afterward appears, represents the vital organs of the embryo fish.

At the end of about 80 to 100 days from the deposition of the egg the fish has so increased in size that it bursts the “shell” and makes its *début* in the form represented at Fig. 3. The sac or umbilical vesi-

FIG. 3.



FISH COMING OUT OF EGG.

cle attached to the under part of the fish contains a secretion resembling albumen, which affords nourishment to the infant fish for the first six weeks or so of its existence. By that time it is quite absorbed, and for the first time we see a perfect fish, Fig. 4, with its fins, gills, and scales, which have hitherto been present, but imperceptible except under the microscope, fully formed: and now the young salmon begins to feed. His growth is not very rapid for some months, the lines *a*, *b*, *c*, representing the average length of a salmon at two, three, and four months old. At two years old the fish is about nine to twelve inches long.

As soon as they are large enough and strong enough, the “smolts,” as they are now called, descend to the sea; here they are lost sight of until they return up the river as “grilse.” The actual duration of their stay in the sea is not yet known, from one to three years being variously estimated as the probable length of time. The object of this migration to the sea is to find the food which is necessary for the secretion of the fat of the fish, who lives on the *Infusoria*, smaller fish and crustaceans, and the spawn of sea-fish, which abound in our seas. The length of their stay in salt-water is regulated, no doubt, by various circumstances, and is not the same in every case. When the salmon has laid up a sufficient supply of fat in its body and on its pyloric appendages, which are a wonderful provision of Nature for the secretion of an amount of fat sufficient to supply it during its so-

jour in fresh waters, it ascends the river, its roe or spawn developing as it ascends; till, about Christmas-time, or sometimes earlier, it reaches the shallow head-streams of the river, in the gravelly beds of which it deposits its eggs, returning immediately afterward to the sea, no longer in the bright, plump, muscular condition in which it ascended, but a lean, lank, ugly, wounded beast, which one would hardly recognize as *Salmo salar*. Fig. 5 represents the head of a "kelt," as those salmon are called which have newly spawned. The curved projection, or hook, on the lower jaw, is a cartilaginous membrane, the use of which nobody knows. The fish is in a very weakly condition, as his fat is gone, and he perhaps assumes this appearance to frighten other animals, which might otherwise be tempted to attack him. The drawing is taken from the photograph of a salmon, weighing twenty pounds, which was found dead on the banks of one of our Welsh rivers.

FIG. 4.

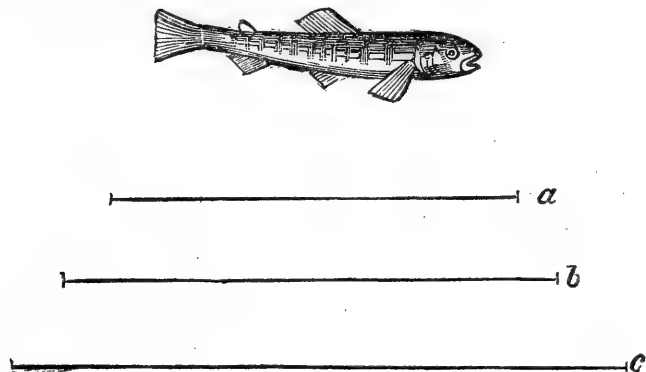

YOUNG SALMON SIX WEEKS OLD.

*a, b, c*, size of salmon at two, three, and four months respectively.

This fish, had it survived, would have returned to sea, recovered its fat, and presently come back worth £2 or £3, whereas, by dying in this condition, it was worth nothing. It had, however, done its duty by depositing perhaps 16,000 eggs. Only a very small percentage, however, of the eggs laid ever become adult fish. Floods wash them out of their gravel nests; ducks, and other birds, eat them; beetles and various insects attack them; they are smothered with mud, or left high and dry on the shore; the young fish are poisoned by pollutions, or diverted into mill-leats and canals, and so lost; trout eat them wholesale; in fact, the whole of their earliest existence is a very living death, and it is a wonder, with all the ordeals they have to pass through, that we have any salmon left. To kill them legitimately for food for ourselves is bad enough, and we ought to do all we can to protect them when young.

In the artificial system of breeding salmon the adult fish are caught just as they are on the spawning-beds, and the eggs taken from them; the ova and milt are properly mixed together, and the eggs placed in

troughs of water so arranged as to imitate as closely as possible the natural conditions necessary for the development and growth of the fish. Properly managed, ninety per cent. of the eggs will hatch out: the young fish are turned into the river when they are about a year old; if they can be kept two years in tanks large enough, with plenty of running water, so much the better for the prospect of their reaching the sea in safety.

FIG. 5.

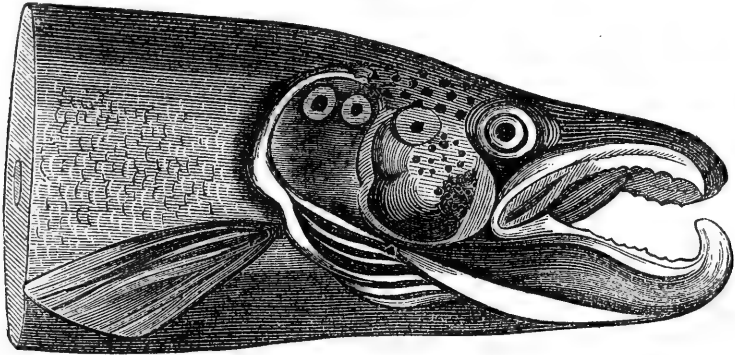

HEAD OF A KELT.

When we can make up our minds to keep all our pollutions out of our rivers, and build "salmon-ladders" over all the weirs, so as to give the fish a fair field, and enable them to run up-stream unimpeded, then, and then only, shall we see salmon as plentiful throughout the country as it is said to have been in the North a century ago, when apprentices are reputed to have stipulated in their indentures that they should be fed on salmon not more than three days a week. Without this, all our efforts to stock our barren rivers with artificially-bred fry will prove comparatively unavailing.—*Nature*.



## PSYCHOLOGY OF THE SEXES.<sup>1</sup>

BY HERBERT SPENCER.

ONE further instance of the need for psychological inquiries as guides to sociological conclusions may be named—an instance of quite a different kind, but one no less relevant to questions of the time. I refer to the comparative psychology of the sexes. Women, as well as men, are units in a society, and tend by their natures to give that society certain traits of structure and action. Hence the question, Are the mental natures of men and women the same? is an important one to the sociologist. If they are, an increase of feminine influence is not likely to affect the social type in a marked manner. If they are

<sup>1</sup> Conclusion of chapter on Mental Science and Sociology.



not, the social type will inevitably be changed by increase of feminine influence.

That men and women are mentally alike, is as untrue as that they are alike bodily. Just as certainly as they have physical differences which are related to the respective parts they play in the maintenance of the race, so certainly have they psychical differences, similarly related to their respective shares in the rearing and protection of offspring. To suppose that along with the unlikenesses between their parental activities there do not go unlikenesses of mental faculties, is to suppose that here alone in all Nature there is no adjustment of special powers to special functions.<sup>1</sup>

Two classes of differences exist between the psychical, as between the physical, structures of men and women, which are both determined by this same fundamental need—adaptation to the paternal and maternal duties. The first set of differences is that which results

<sup>1</sup> The comparisons ordinarily made between the minds of men and women are faulty in many ways, of which these are the chief :

Instead of comparing either the average of women with the average of men, or the *élite* of women with the *élite* of men, the common course is to compare the *élite* of women with the average of men. Much the same erroneous impression results as would result if the relative statures of men and women were judged by putting very tall women side by side with ordinary men.

Sundry manifestations of nature in men and women are greatly perverted by existing social conventions upheld by both. There are feelings which, under our predatory *régime*, with its adapted standard of propriety, it is not considered manly to show ; but which, contrariwise, are considered admirable in women. Hence, repressed manifestations in the one case, and exaggerated manifestations in the other ; leading to mistaken estimates.

The sexual sentiment comes into play to modify the behavior of men and women to one another. Respecting certain parts of their general characters, the only evidence which can be trusted is that furnished by the conduct of men to men, and of women to women, when placed in relations which exclude the personal affections.

In comparing the intellectual powers of men and women, no proper distinction is made between receptive faculty and originative faculty. The two are scarcely commensurable ; and the receptivity may, and frequently does, exist in high degree where there is but a low degree of originality, or entire absence of it.

Perhaps, however, the most serious error usually made in drawing these comparisons is, that of overlooking the limit of normal mental power. Either sex under special stimulations is capable of manifesting powers ordinarily shown only by the other ; but we are not to consider the deviations so caused as affording proper measures. Thus, to take an extreme case, the mammæ of men will, under special excitation, yield milk : there are various cases of gynæcomasty on record, and in families, infants whose mothers have died have been thus saved. But this ability to yield milk, which, when exercised, must be at the cost of masculine strength, we do not count among masculine attributes. Similarly, under special discipline, the feminine intellect will yield products higher than the intellects of most men can yield. But we are not to count this as truly feminine if it entails decreased fulfillment of the maternal functions. Only that mental energy is normally feminine which can coexist with the production and nursing of the due number of healthy children. Obviously a power of mind which, if general among the women of a society, would entail disappearance of the society, is a power not to be included in an estimate of the feminine nature as a social factor.



from a somewhat earlier arrest of individual evolution in women than in men, necessitated by the reservation of vital power to meet the cost of reproduction. Whereas, in man, individual evolution continues until the physiological cost of self-maintenance very nearly balances what nutrition supplies, in woman, an arrest of individual development takes place while there is yet a considerable margin of nutrition: otherwise there could be no offspring. Hence the fact that girls come earlier to maturity than boys. Hence, too, the chief contrasts in bodily form: the masculine figure being distinguished from the feminine by the greater relative sizes of the parts which carry on external actions and entail physiological cost—the limbs, and those thoracic viscera which their activity immediately taxes. And hence, too, the physiological truth that, throughout their lives, but especially during the child-bearing age, women exhale smaller quantities of carbonic acid, relatively to their weights, than men do; showing that the evolution of energy is relatively less as well as absolutely less. This rather earlier cessation of individual evolution thus necessitated, showing itself in a rather smaller growth of the nervo-muscular system, so that both the limbs which act and the brain which makes them act are somewhat less, has two results on the mind. The mental manifestations have somewhat less of general power or massiveness; and beyond this there is a perceptible falling short in those two faculties, intellectual and emotional, which are the latest products of human evolution—the power of abstract reasoning and that most abstract of the emotions, the sentiment of justice—the sentiment which regulates conduct irrespective of personal attachments and the likes or dislikes felt for individuals.<sup>1</sup>

After this quantitative mental distinction, which becomes incidentally qualitative by telling most upon the most recent and most complex faculties, there come the qualitative mental distinctions consequent on the relations of men and women to their children and to one another. Though the parental instinct, which, considered in its essential nature, is a love of the helpless, is common to the two; yet it is obviously not identical in the two. That the particular form of it which responds to infantine helplessness is more dominant in women than in men, cannot be questioned. In man the instinct is not so habitually excited by the very helpless, but has a more generalized relation to all the relatively weak who are dependent upon him. Doubtless, along with this more specialized instinct in women, there go special aptitudes for dealing with infantine life—an adapted power of intuition and a fit adjustment of behavior. That there is here a mental specialization, joined with the bodily specialization, is undeniable;

<sup>1</sup> Of course it is to be understood that in this, and in the succeeding statements, reference is made to men and women of the same society, in the same age. If women of a more-evolved race are compared with men of a less-evolved race, the statement will not be true.

and this mental specialization, though primarily related to the rearing of offspring, affects in some degree the conduct at large.

The remaining qualitative distinctions between the minds of men and women are those which have grown out of their mutual relation as stronger and weaker. If we trace the genesis of human character, by considering the conditions of existence through which the human race passed in early barbaric times and during civilization, we shall see that the weaker sex has naturally acquired certain mental traits by its dealings with the stronger. In the course of the struggles for existence among wild tribes, those tribes survived in which the men were not only powerful and courageous, but aggressive, unscrupulous, intensely egoistic. Necessarily, then, the men of the conquering races which gave origin to the civilized races, were men in whom the brutal characteristics were dominant; and necessarily the women of such races, having to deal with brutal men, prospered in proportion as they possessed, or acquired, fit adjustments of nature. How were women, unable by strength to hold their own, otherwise enabled to hold their own? Several mental traits helped them to do this.

We may set down, first, the ability to please, and the concomitant love of approbation. Clearly, other things equal, among women living at the mercy of men, those who succeeded most in pleasing would be the most likely to survive and leave posterity. And (recognizing the predominant descent of qualities on the same side) this, acting on successive generations, tended to establish, as a feminine trait, a special solicitude to be approved, and an aptitude of manner to this end.

Similarly, the wives of merciless savages must, other things equal, have prospered in proportion to their powers of disguising their feelings. Women who betrayed the state of antagonism produced in them by ill-treatment would be less likely to survive and leave offspring than those who concealed their antagonism; and hence, by inheritance and selection, a growth of this trait proportionate to the requirement. In some cases, again, the arts of persuasion enabled women to protect themselves, and by implication their offspring, where, in the absence of such arts, they would have disappeared early, or would have reared fewer children. One further ability may be named as likely to be cultivated and established—the ability to distinguish quickly the passing feelings of those around. In barbarous times, a woman who could, from a movement, tone of voice, or expression of face, instantly detect in her savage husband the passion that was rising, would be likely to escape dangers run into by a woman less skilled in interpreting the natural language of feeling. Hence, from the perpetual exercise of this power, and the survival of those having most of it, we may infer its establishment as a feminine faculty. Ordinarily, this feminine faculty, showing itself in an aptitude for guessing the state of mind through the external signs, ends simply in intuitions formed without assignable reasons; but when, as happens in

rare cases, there is joined with it skill in psychological analysis, there results an extremely remarkable ability to interpret the mental states of others. Of this ability we have a living example never hitherto paralleled among women, and in but few, if any, cases exceeded among men.

Of course, it is not asserted that the specialties of mind here described as having been developed in women, by the necessities of defense in their dealings with men, are peculiar to them: in men also they have been developed as aids to defense in their dealings with one another. But the difference is, that, whereas, in their dealings with one another, men depended on these aids only in some measure, women in their dealings with men depended upon them almost wholly—within the domestic circle as well as without it. Hence, in virtue of that partial limitation of heredity by sex, which many facts throughout Nature show us, they have come to be more marked in women than in men.<sup>1</sup>

One further distinctive mental trait in women springs out of the relation of the sexes as adjusted to the welfare of the race. I refer to the effect which the manifestation of power of every kind in men has in determining the attachments of women. That this is a trait inevitably produced will be manifest, on asking what would have happened if women had by preference attached themselves to the weaker men. If the weaker men had habitually left posterity when the stronger did not, a progressive deterioration of the race would have resulted. Clearly, therefore, it has happened (at least since the cessation of marriage by capture or by purchase has allowed feminine choice to play an important part) that, among women unlike in their

<sup>1</sup> As the validity of this group of inferences depends on the occurrence of that partial limitation of heredity of sex here assumed, it may be said that I should furnish proof of its occurrence. Were the place fit, this might be done. I might detail evidence that has been collected showing the much greater liability there is for a parent to bequeath malformations and diseases to children of the same sex, than to those of the opposite sex. I might cite the multitudinous instances of sexual distinctions, as of plumage in birds and coloring in insects, and especially those marvelous ones of dimorphism and polymorphism among females of certain species of Lepidoptera, as necessarily implying (to those who accept the Hypothesis of Evolution) the predominant transmission of traits to descendants of the same sex. It will suffice, however, to instance, as more especially relevant, the cases of sexual distinctions within the human race itself, which have arisen in some varieties and not in others. That in some varieties the men are bearded, and in others not, may be taken as strong evidence of this partial limitation of heredity; and, perhaps, still stronger evidence is yielded by that peculiarity of feminine form found in some of the negro races, and especially the Hottentots, which does not distinguish to any such extent the women of other races from the men. There is also the fact, to which Agassiz draws attention, that, among the South American Indians, males and females differ less than they do among the negroes and the higher races; and this reminds us that among European and Eastern nations the men and women differ, both bodily and mentally, not quite in the same ways and to the same degrees, but in somewhat different ways and degrees—a fact which would be inexplicable were there no partial limitation of heredity by sex.

tastes, those who were fascinated by power, bodily or mental, and who married men able to protect them and their children, were more likely to survive in posterity than women to whom weaker men were pleasing, and whose children were both less efficiently guarded and less capable of self-preservation if they reached maturity. To this admiration for power, caused thus inevitably, is ascribable the fact sometimes commented upon as strange, that women will continue attached to men who use them ill, but whose brutality goes along with power, more than they will continue attached to weaker men who use them well. With this admiration of power, primarily having this function, there goes the admiration of power in general, which is more marked in women than in men, and shows itself both theologically and politically. That the emotion of awe aroused by contemplating whatever suggests transcendent force or capacity, which constitutes religious feeling, is strongest in women, is proved in many ways. We read that among the Greeks the women were more religiously excitable than the men. Sir Rutherford Alcock tells us of the Japanese that "in the temples it is very rare to see any congregation except women and children; the men, at any time, are very few, and those generally of the lower classes." Of the pilgrims to the temple of Juggernaut, it is stated that "at least five-sixths, and often nine-tenths, of them are females." And we are also told of the Sikhs, that the women believe in more gods than the men do. Which facts, coming from different races and times, sufficiently show us that the like fact, familiar to us in Roman Catholic countries, and to some extent at home, is not, as many think, due to the education of women, but has a deeper cause in natural character. And to this same cause is in like manner to be ascribed the greater respect felt by women for all embodiments and symbols of authority, governmental and social.

Thus the *a priori* inference, that fitness for their respective parental functions implies mental differences between the sexes, as it implies bodily differences, is justified; as is also the kindred inference that secondary differences are necessitated by their relations to one another. Those unlikenesses of mind between men and women, which, under the conditions, were to be expected, are the unlikenesses we actually find. That they are fixed in degree, by no means follows: indeed, the contrary follows. Determined as we see they some of them are by adaptation of primitive women's natures to the natures of primitive men, it is inferable that as civilization readjusts men's natures to higher social requirements, there goes on a corresponding readjustment between the natures of men and women, tending in sundry respects to diminish their differences. Especially may we anticipate that those mental peculiarities developed in women, as aids to defense against men in barbarous times, will diminish. It is probable, too, that, though all kinds of power will continue to be attractive to them, the attractiveness of physical strength and the mental attributes that commonly go along with it will decline, while the attributes which

conduce to social influence will become more attractive. Further, it is to be anticipated that the higher culture of women, carried on within such limits as shall not unduly tax the *physique* (and here, by higher culture, I do not mean mere language-learning and an extension of the detestable cramming-system at present in use), will in other ways reduce the contrast. Slowly leading to the result everywhere seen throughout the organic world, of a self-preserving power inversely proportionate to the race-preserving power, it will entail a less early arrest of individual evolution, and a diminution of those mental differences between men and women which the early arrest produces.

Admitting such to be changes which the future will probably see wrought out, we have meanwhile to bear in mind these traits of intellect and feeling which distinguish women, and to take note of them as factors in social phenomena—much more important factors than we commonly suppose. Considering them in the above order, we may note, first, that the love of the helpless, which in her maternal capacity woman displays in a more special form than man, inevitably affects all her thoughts and sentiments; and, this being joined in her with a less developed sentiment of abstract justice, she responds more readily when appeals to pity are made than when appeals are made to equity. In foregoing chapters we have seen how much our social policy disregards the claims of individuals to whatever their efforts purchase, so long as no obvious misery is brought on them by the disregard; but, when individuals suffer in ways conspicuous enough to excite commiseration, they get aid, and often as much aid if their sufferings are caused by themselves as if they are caused by others—often greater aid, indeed. This social policy, to which men tend in an injurious degree, women tend to still more. The maternal instinct delights in yielding benefits apart from deserts; and, being partially excited by whatever shows a feebleness that appeals for help (supposing antagonism has not been aroused), carries into social action this preference of generosity to justice, even more than men do. A further tendency, having the same general direction, results from the aptitude which the feminine intellect has to dwell on the concrete and proximate rather than on the abstract and remote. The representative faculty in women deals quickly and clearly with the personal, the special, and the immediate; but less readily grasps the general and the impersonal. A vivid imagination of simple direct consequences mostly shuts out from her mind the imagination of consequences that are complex and indirect. The respective behaviors of mothers and fathers to children sufficiently exemplify this difference: mothers thinking chiefly of present effects on the conduct of children, and regarding less the distant effects on their characters; while fathers often repress the promptings of their sympathies with a view to ultimate benefits. And this difference between their ways of estimating consequences, affecting their judgments on social affairs as on

domestic affairs, makes women err still more than men do in seeking what seems an immediate public good without thought of distant public evils. Once more, we have in women the predominant awe of power and authority, swaying their ideas and sentiments about all institutions. This tends toward the strengthening of governments, political and ecclesiastical. Faith in whatever presents itself with imposing accompaniments is, for the reason above assigned, especially strong in women. Doubt, or criticism, or calling in question of things that are established, is rare among them. Hence in public affairs their influence goes toward the maintenance of controlling agencies, and does not resist the extension of such agencies; rather, in pursuit of immediate promised benefits, it urges on that extension; since the concrete good in view excludes from their thoughts the remote evils of multiplied restraints. Reverencing power more than men do, women, by implication, respect freedom less—freedom, that is, not of the nominal kind, but of that real kind which consists in the ability of each to carry on his own life without hindrance from others, so long as he does not hinder them.

As factors in social phenomena, these distinctive mental traits of women have ever to be remembered. Women have in all times played a part, and, in modern days, a very notable part, in determining social arrangements. They act both directly and indirectly. Directly, they take a large, if not the larger, share in that ceremonial government which supplements the political and ecclesiastical governments; and as supporters of these other governments, especially the ecclesiastical, their direct aid is by no means unimportant. Indirectly, they act by modifying the opinions and sentiments of men—first, in education, when the expression of maternal thoughts and feelings affects the thoughts and feelings of boys, and afterward in domestic and social intercourse, during which the feminine sentiments sway men's public acts, both consciously and unconsciously. Whether it is desirable that the share already taken by women in determining social arrangements and actions should be increased, is a question we will leave undiscussed. Here I am concerned merely to point out that, in the course of a psychological preparation for the study of Sociology, we must include the comparative psychology of the sexes; so that, if any change is made, we may make it knowing what we are doing.

Assent to the general proposition set forth in this chapter does not depend on assent to the particular propositions unfolded in illustrating it. Those who, while pressing forward education, are so certain they know what good education is, that, in an essentially Papal spirit, they wish to force children through their existing school-courses under penalty on parents who resist, will not have their views modified by what has been said. I do not look, either, for any appre-



ciable effect on those who shut out from consideration the reactive influence on moral nature, entailed by the action of a system of intellectual culture which habituates parents to make the public responsible for their children's minds. Nor do I think it likely that many of those who wish to change fundamentally the political *status* of women will be influenced by the considerations above set forth on the comparative psychology of the sexes. But, without acceptance of these illustrative conclusions, there may be acceptance of the general conclusion, that psychological truths underlie sociological truths, and must therefore be sought by the sociologist. For whether discipline of the intellect does or does not change the emotions; whether national character is or is not progressively adapted to social conditions; whether the minds of men and women are or are not alike—are obviously psychological questions; and either answer to any one of them implies a psychological conclusion. Hence, whoever, on any of these questions, has a conviction to which he would give legislative expression, is basing a sociological belief upon a psychological belief; and cannot deny that the one is true only if the other is true. Having admitted this, he must admit that without preparation in Mental Science there can be no Social Science. For, otherwise, he must assert that the randomly-made and carelessly-grouped observations on Mind, common to all people, are better as guides than observations cautiously collected, critically examined, and generalized in a systematic way.

No one, indeed, who is once led to dwell on the matter, can fail to see how absurd is the supposition that there can be a rational interpretation of men's combined actions, without a previous rational interpretation of those thoughts and feelings by which their individual actions are prompted. Nothing comes out of a society but what originates in the motive of an individual, or in the united similar motives of many individuals, or in the conflict of the united similar motives of some having certain interests with the diverse motives of others whose interests are different. Always the power which initiates a change is feeling, separate or aggregated, guided to its ends by intellect; and not even an approach to an explanation of social phenomena can be made, without the thoughts and sentiments of citizens being recognized as factors. How, then, can there be a true account of social actions without a true account of these thoughts and sentiments? Manifestly, those who ignore Psychology as a preparation for Sociology, can defend their position only by proving that while other groups of phenomena require special study, the phenomena of Mind, in all their variety and intricacy, are best understood without special study; and that knowledge of human nature gained hap-hazard becomes obscure and misleading in proportion as there is added to it knowledge deliberately sought and carefully put together.



## THE RINGED PLANET.

**D**URING the months of September, October, and November, Mars and Saturn are companions as evening-stars. It will not be difficult to recognize them, though the ruddy glories of Mars have been greatly reduced since July and August, when he shared with Jupiter the dominion over the western skies after sunset. The dull-yellow lustre of Saturn differs markedly from the red but more star-like light of Mars; and, as the two planets draw near to each other late in November (making their nearest approach on the 20th), it will be interesting to observe the contrast between the red and yellow planets of the solar system. Striking, however, as this contrast will be found to be, it is insignificant compared with the real contrast which exists between the two planets. Mars is the least but one of the primary members of the solar family, and, although he pursues a course outside the earth's, he is unlike all the other superior planets in being unaccompanied by any moon; his small orb, also, appears to have but a shallow atmospheric envelope, while in physical constitution he apparently occupies a position between the earth and the moon. Saturn, on the other hand, is inferior only to Jupiter in dimensions and mass, while he is superior to Jupiter not only in the astronomical sense that he travels on a wider orbit, but in the extent and importance of the scheme over which he bears sway; his orb, moreover, like that of Jupiter, appears to be the scene of marvelous processes of change, implying a condition altogether unlike that of the earth on which we live.

We propose to give a brief sketch of what has been ascertained respecting this wonderful planet, the most beautiful telescopic object in the whole heavens, and the one which throws the clearest light upon the nature of the solar system, and particularly of those giant planets which circle outside the zone of asteroids.

We would at the outset impress upon the reader the necessity of raising his thoughts above those feeble conceptions respecting Saturn and his system which are suggested by the ordinary pictures of the planet. When we see Saturn presented as a ball within a ring, or more carefully pictured as a striped globe within a system of rings, we are apt to regard the ideas suggested by such drawings as affording a true estimate of the planet's nature. In fact, many believe that the planet and its rings are really like what is presented in these pictures. It should be understood that what has been actually seen of Saturn by telescopic means cannot, in the nature of things, afford any true picture of the planet and its ring system. The picture must be filled in, not by the imagination, but by the aid of reason; and then, though much will still remain unknown, we shall have at least a far juster conception of the glories of the ringed world than when we simply

contemplate drawings which show how the planet looks under telescopic scrutiny. This will at once appear when we consider that Saturn never lies at a less distance than 732,000,000 miles from the earth. With the most powerful telescope we see him no better (taking atmospheric effects into account) than we should if this distance were reduced to about a million miles. It is manifest that at this enormous distance all save the general features of his globe and of his rings must be indistinguishable. Where we seem to see a smooth, solid globe striped with belts, there may be an orb no part of which is solid,

FIG. 1.

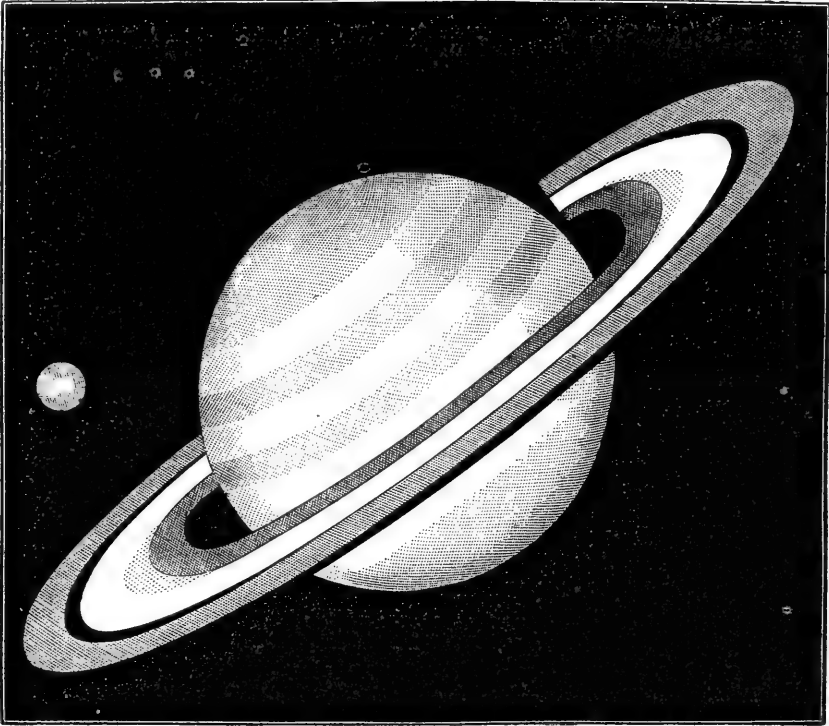

TELESCOPIC ASPECT OF SATURN, AND SIZE COMPARED WITH THE EARTH.

girt round by masses of matter lying many miles above its seeming surface. Where we seem to see solid, flat rings, neatly divided one from the other either by dark spaces or by difference of tint, there may be no continuous rings at all; the apparent spaces may be no real gaps; the difference of tint may imply no difference of material. On these and other points, the known facts afford important evidence, and, by reasoning upon them, we are carried far beyond the results directly conveyed to us by telescopic researches.

Saturn is distinguished, in the first place, by the enormous range of his orbit, not merely in distance from the sun, but in the distances which separate it from the orbits of his neighbor planets. His mean distance from the sun is about 872,000,000 miles, his actual range of distance lying between 921,000,000 and 823,000,000. These figures are imposing, but they are, in fact, meaningless save by comparison with

other distances of the same class. Let it be noticed, then, that Saturn's mean distance from the sun exceeds the earth's more than nine and a half times. Now, Jupiter's distance exceeds the earth's rather more than five times (five and a fifth is very nearly the true proportion); so that between Jupiter's path and Saturn's there lies everywhere a span fully equal to four times the earth's distance from the sun. So much for Saturn's nearest neighbor on that side. But on the farthest side lies Uranus, more than nineteen times as far away from the sun as our earth is; so that between the paths of Saturn and Uranus there lies everywhere a span equal to Saturn's own distance from the sun. Now, all this is not intended as a mere display of wonderful distances. So far as mere dimensions are concerned, these arrays of figures are more imposing than impressive. But, so soon as we take into account the circumstance that a planet is in some sense ruler over the spaces through which its course carries it, those spaces being by no means tenantless, we see that, *cæteris paribus*, the dignity of a planet is enhanced by the extent of the space separating its orbit from the orbits of its neighbors on either side. Now, the space between the paths of Saturn and Jupiter exceeds the space inclosed by the earth's orbit no less than 63 times, while the space between the paths of Saturn and Uranus exceeds the space inclosed by the earth's orbit 270 times! Assuming (as we seem compelled to do by continually-growing evidence) that Saturn and his system were formed by the gathering in of matter from the region over which Saturn now bears sway, we cannot wonder that the planet is a giant, and his system wonderful in extent and complexity of structure. It is true that Jupiter on one side, and Uranus on the other, share Saturn's rule over the vast space, 330 times the whole space circled round by the earth, which lies between the orbits of his neighbor planets. But Saturn's rule is almost supreme over the greater part of that enormous space. Combining the vastness of the space with its position—not so near to the sun that solar influence can greatly interfere with Saturn's, nor so far away as to approach the relatively-barren outskirts of the solar system—we seem to find a sufficient explanation of Saturn's *high* position in the scheme of the planets as respects volume and mass, and his *foremost* position as respects the complexity of the system over which he bears sway.

Briefly, then, to indicate his proportions, and the dimensions of his system:

Saturn has a globe considerably flattened, his equatorial diameter being about 70,000 miles, while his polar axis is nearly 7,000 miles shorter. Thus in volume he exceeds the earth nearly 700 times, and all the four terrestrial planets—Mercury, Venus, the Earth, and Mars—taken together, more than 336 times. In mass he does not exceed the earth and these other smaller planets so enormously, because his density (regarding him as a whole) is much less than the earth's. In fact, his density is less than that of any other known body (comets,

of course, excepted) in the solar system. The reader is doubtless aware that the sun's mean density is almost exactly one-fourth of the earth's; Jupiter's is almost exactly the same as the sun's; but Saturn's is little more than half the sun's, being represented by the number 13 only, where 100 represents the earth's. Thus, instead of exceeding the earth nearly 700 times in mass, as he would if he were of the same density, he exceeds her but about 90 times. But this disproportion must still be regarded as enormous, especially when it is added that the combined mass of the four terrestrial planets amounts to little more than the forty-fourth part of Saturn's mass. The combined mass of Uranus and Neptune, though these are members of the family of major planets, falls short of one-third of Saturn's mass; yet, by comparison with Jupiter, whose mass exceeds his more than threefold, Saturn appears almost dwarfed. And it may be noted as a striking circumstance—one that is not sufficiently recognized in our astronomical treatises—that, while Jupiter's mass exceeds the combined mass of all the other planets (including Saturn) about two and a half times, Saturn exceeds all the remaining planets in mass about two and three-quarter times. So unequally is the material of the planetary system distributed.

FIG. 2.

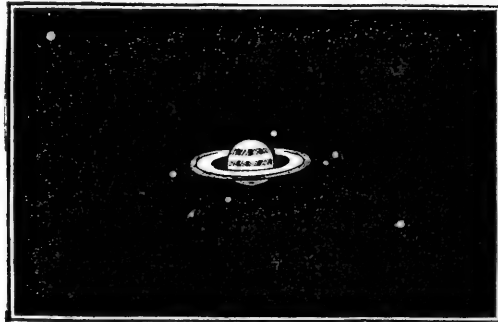

SATURN AND HIS MOONS.

The mighty globe of Saturn rotates on its axis in about nine hours and a half, the most rapid rotation in the solar system so far as is yet known.

But what shall we say to indicate adequately the dimensions of that enormous ring-system which circles around Saturn? Here we have no unit of comparison, and scarcely any mode of presenting the facts except the mere statement of numerical relations. Thus the full span of the rings, measured across the centre of the planet, amounts to 167,000 miles; the full breadth of the ring-system amounts to 35,600 miles. But these numbers convey only imperfect ideas. Perhaps the best way of indicating the enormous extent of the ring-system is to mention that circumnavigation of the world by a ship sailing from England to New Zealand by the Cape of Good Hope, and from New Zealand to England by Cape Horn, would have to be repeated 21 times to give a distance equaling the outer circumference of

the ring-system. The same double journey amounts in distance to but about two-thirds the breadth of the ring-system.

As to the scale on which Saturn's system of satellites is constructed, we shall merely remark that the span of the outermost satellite's orbit exceeds nearly twofold the complete span of the Jovian system of satellites, and exceeds the span of our moon's orbit nearly tenfold.

And now let us consider what is the probable nature of the vast orb which travels—girt round always by its mighty ring-system—at so enormous a distance from the sun that his disk has but the ninetyeth part of the size of the solar disk we see. Have we in Saturn, as has been so long the ordinary teaching of astronomy, a world like our own, though larger—the abode of millions on millions of living creatures—or must we adopt a totally different view of the planet, regarding it as differing as much from our earth as our earth differs from the moon, or as Saturn and Jupiter differ from the sun?

We must confess that, if we set on one side altogether the ideas received from books on astronomy, endeavoring to view these questions independently of all preconceived opinions, it appears antecedently improbable that Saturn or Jupiter can resemble the earth either in attributes or purpose. We conceive that, if a being capable of traversing at will the interstellar spaces were to approach the neighborhood of our solar system, and to form his opinion respecting it from what he had observed in other parts of the sidereal universe, he would regard Jupiter and Saturn, the brother giants of our system, as resembling rather those companion orbs which are seen in the case of certain unequal double stars, than small dependent worlds like our earth and Venus. There are, perhaps, no instances known to our telescopists in which the disparity of *light*, as distinguished from real magnitude, is quite so great as that which exists in the case of the sun and the two chief planets of the solar system.<sup>1</sup> But we see in the heaven of the fixed stars all orders of disproportion between double stars, from the closest approach to equality down to such extreme inequality, that, while the larger star of the pair is one of the leading brilliants of the heavens, the smaller can only just be discerned with the largest telescopes yet made, used on the darkest and clearest nights. We have no

<sup>1</sup> Even this is not certain. Jupiter, seen in full illumination from a stand-point so distant that both Jupiter and the sun might be regarded as equally distant from it, would appear to shine with rather more than the 3,000th part of the sun's light. This would correspond to the difference of apparent brightness between two stars of equal real magnitude and splendor, whereof one was about 54 times as far away as the other. There can be no doubt that the larger reflectors of the Herschels, Rosse, and Lassell, and the great refractors of Greenwich, Pulkowa, and Cambridge (United States), would bring the farther of two such stars into view if the nearer were of the first or second magnitude; and it is not at all unlikely that some of the exceedingly minute companions to bright stars, disclosed by these instruments, may be planets shining with reflected, not with inherent lustre.

reason to believe that the series stops just where our power of tracing it ceases; on the contrary, since the series is continuous as far as it goes, and since our own solar system is constituted as if it belonged to the series prolonged far beyond the limits which telescopic scrutiny has reached, we have reason for believing that such is indeed the interpretation of the observed facts. In other words, we may not unreasonably regard our solar system as a multiple system, a double star at certain ranges of distance, whence only the sun and Jupiter could be seen; a triple star at distances whence Saturn could be seen; and a quintuple star where Uranus and Neptune would come into view. To show what excellent reason exists for regarding Mercury, Venus, the Earth, and Mars, as not to be included in this view, it is only necessary to remark that not one of these planets could be seen until the limits of the solar system had been crossed. To eyesight such as ours, not one of the four terrestrial planets could be seen from Saturn, and still less, of course, from Uranus or Neptune. It would be as unreasonable to hold the ring of asteroids, or even the myriads of systems of meteorolites and aërolites, to be bodies resembling the earth and her fellow-terrestrial planets, as it is to hold these terrestrial planets to be bodies resembling Jupiter and his fellow-giants.

In all characteristics yet recognized by astronomers, Jupiter and Saturn differ most markedly from the earth and her fellow-planets. In bulk and mass they belong manifestly to a different order of created things; in density they differ more from the earth than the sun does; they rotate much more swiftly on their axes; they receive much less light and heat from the sun; the lengths of their year exceed the length of the earth's year as remarkably as their day falls short of hers; the atmospheric envelope of each is divided into variable belts, utterly unlike any thing existing in the earth's atmosphere; and, lastly, each is the centre of an important subsidiary scheme of bodies quite unlike the moon (the only secondary planet in the terrestrial family) as respects their relations to the primary around which they travel.

Notwithstanding all these circumstances in evidence of utter dissimilarity, and the fact that not one circumstance in the condition of the major planets suggests resemblance to the terrestrial planets, astronomy continues to treat of the planets of the solar system as though they formed a single family. It would appear as though the teachings of the astronomers who lived before the telescope was invented had so strong an inherent vitality, that more than two centuries and a half of discoveries adverse to those teachings are powerless to dispossess them of their authority. For no other reason can be suggested, as it appears to me, for the complete disregard with which the most striking characteristics of the major planets have been treated by modern astronomers.

If we consider one feature alone of those which have been just



mentioned—the small mean density of the giant planets—we have at once the strongest possible evidence to show that the condition of these bodies must be unlike that of the earth. Of course, if we assume that Saturn's substance (to limit our attention to this planet) is composed of materials altogether unlike any which exist on earth, a way out of our difficulty is found, though not an easy one. In that case, however, we are only substituting one form of complete dissimilarity for another. And all the results of spectroscopic analysis, as applied to the celestial bodies, tend to show the improbability that such differences of elementary constitution exist—we will not say in the solar system only, but in the sidereal universe itself. If, however, we admit that Saturn is in the main constituted of elements such as we are familiar with, we find it extremely difficult, or rather it is absolutely impossible, to suppose that the condition of his substance is like that of the earth's. There are certain unmistakable facts to be accounted for. *There* is the mighty mass of Saturn, exceeding that of the earth ninety-fold. That mass is endued with gravitating energy, precisely in the same way as the earth's mass. There must be from the surface toward the centre a continually increasing pressure. This pressure is calculable,<sup>1</sup> and enormously exceeds the internal pressures existing within the earth's interior. There is no possibility of cavities, as Brewster and others have opined; for there is no known material, not the strongest known to us, iron, or platinum, or adamant, which could resist the pressures produced by Saturn's internal gravitation. Steel would be as yielding as water under these pressures. There must be compression with its consequent increase of density, such compression exceeding many million-fold the greatest with which terrestrial experimenters have dealt. That, with these enormous forces at work, the actual density of Saturn as a whole should be far less than that of water is utterly inexplicable, unless Saturn's *condition* be regarded as altogether unlike that of the earth. We see in the sun an orb which, notwithstanding its enormous mass, has a mean density much less than the earth's, and little greater than that of water; but we have no difficulty in understanding this circumstance, because we

<sup>1</sup> It is a misfortune for science that Newton never published the reasoning which led him to the conclusion that the earth's mean density is equal to between five and six times the density of water. This, as every one knows, has been confirmed by several experimental methods; and, so far as appears, the problem is a purely experimental one. Newton, however, made no experiments; at least, none have been heard of as effected by him, and it is scarcely probable that he had any instruments of sufficient delicacy for a task so difficult. Prof. Grant ascribes Newton's conclusion to a happy intuition; yet it is very unlike Newton to make a guess on such a matter. It is more probable that he guessed the elements of the problem than the result. He probably assumed that the earth's mass is composed of a substance like granite, and, adopting some law of compression for such a substance (based on experiment, perhaps), calculated thence the compression at different depths, and so obtained the mean density of the whole mass.



see that the sun is in a state of intense heat, and we know that this heat produces effects antagonistic, as it were, to those produced by the attraction of his mass as a whole upon every portion of his substance. But, if we make no similar assumption in Saturn's case, we find his small density inexplicable.

Another circumstance associated with the question of Saturn's density introduces new difficulties of the most perplexing nature if it be regarded according to the ordinary view, while it seems not only explicable, but manifestly to be expected, on the theory that Saturn's whole orb is in an intensely heated condition. Saturn certainly has an atmosphere of considerable depth. The belts which surround his globe are evidently produced by clouds in his atmosphere, though what the nature of these clouds may be is not as yet known. The brighter belts are the cloud-belts, while the darker either show his real surface, or, far more probably, belong simply to lower cloud-layers. These belts are variable in appearance and position, sometimes changing with great rapidity. Their real extent is enormous, exceeding the whole surface of our earth, even in the case of the narrowest belts yet seen. No one who has viewed them through telescopes of great power can refuse to adopt the conclusion that the atmosphere in which these great cloud-zones are suspended must be of great depth, certainly far deeper than our atmosphere. But such an atmosphere, subjected to the attractions of Saturn's mass, would be enormously compressed underneath those manifestly thick cloud-layers. A very moderate assumption as to the depth of the atmosphere would lead to the conclusion that at its base it must be denser than water—that is, denser than Saturn himself. No gas could exist *as* gas at this density. Apart from this, we are here arriving at the very theory which the ordinary view of Saturn teaches us to avoid—viz., the theory that he is utterly unlike our earth in physical condition. We may much more conveniently arrive at the same general conclusion, while avoiding other difficulties, by simply adopting the same explanation in this case which serves to account also for the small density of Saturn's mass—viz., the theory that Saturn's globe is in a state of intense heat.

But now let it be noticed how perfectly this view of Saturn's condition accords with the theories which are beginning to be established respecting the genesis of the solar system. Whether we regard the planets as formed from the condensation of enormous nebulous masses, or whether we assume that they were produced by the gathering together of matter originally traveling in dense meteoric flights around the central aggregation whence the sun was one day to be formed, we see that the larger the planet the greater must have been its original heat. The heat generated during the condensation of a nebulous mass must depend upon the magnitude of the mass, since in fact the accepted theory of heat teaches us that the original heat of a globe so

formed is measurable by the actual difference in dimensions between the globe and its parent cloud-mass, and of course the larger the cloud-mass the greater this difference would necessarily be. It is equally certain that the heat generated by the gathering-in of meteoric matter would be so much the greater according as the quantity of matter gathered and gathering was greater; for the heat is produced by the downfall of such matter on the globe it helps to form, and the greater the mass of that globe the greater is its attracting might, the greater the velocity it generates in the falling meteors, and therefore the greater the heat produced when they are brought to rest.

Saturn, then, would originally be much hotter than our earth, on any theory of the *evolution* of our solar system—and there are few astronomers who doubt that the solar system *was* wrought by processes of evolution to its present condition. But not only would Saturn be much hotter than the earth, but, owing to his enormous size, he would part with his heat at a much slower rate. On both accounts we should infer that at this present time Saturn is much hotter than the earth—in other words, since our earth still retains no inconsiderable proportion of its original heat, Saturn may be assumed to be in a state of intense heat. What his actual heat may be is not so easily determined. We shall presently show reasons for believing that an inferior limit, below which his heat does not lie, is indicated by the fact that he still possesses inherent luminosity. On the other hand, a superior limit is indicated by the fact that his inherent luminosity is not great, and that, in all probability, the thicker cloud-zones of Saturn prevent the passage of the greater part of his light.<sup>1</sup>

We should infer, then, that Saturn in some respects resembles the sun, though of course the very same reasoning which teaches us to believe that Saturn is very much hotter than the earth, leads us also to the conclusion that it is not nearly so hot as the sun. Now, thus viewing Saturn, we should be led to expect, apart from all telescopic evidence to that effect, that he would resemble the sun in certain general features. For instance, we might expect that he would have spot-zones, while his equatorial zone would be free from spots; or, if it were thought that so close a resemblance was not to be looked for, then we might still expect that his equatorial zone, like the sun's, would be distinguished from the rest of his surface by some well-marked peculiarity. This is the case. The equatorial zone of Saturn is distinguished by a peculiar brightness from the rest of his surface, insomuch that the late Prof. Nichol was led to regard this zone as the

<sup>1</sup> To prevent misapprehension, it may be as well to remind the reader that the apparent continuity of Saturn's cloud-belts by no means implies that they are really continuous, and it is on a *priori* grounds highly improbable that they are so; openings in his cloud-zones two or three hundred miles in length and breadth would be quite undiscernible at Saturn's enormous distance.

scene of a constant precipitation of meteoric matter from the inside of the ring-system.

Now, there is one important peculiarity which distinguishes the equatorial bright zone of Saturn from that of Jupiter. Jupiter's axis is almost square to the level of the path in which he travels around the sun; so that his equatorial zone lies nearly in that level, and is therefore directly illuminated by the sun. The aspect of Jupiter in fact, as seen from the sun, is *always* that which our earth presents in spring and autumn. But Saturn has an axis very considerably sloped to the level of the path in which he travels. It is more sloped even than our earth's axis. So that in the course of his long year of 10,759 days ( $29\frac{1}{2}$  of our years) Saturn's globe presents toward the sun all the varying aspects which our earth presents, only with a somewhat greater range of variation. At one time he is placed as our earth is in spring, and then his equatorial belt, as seen from the sun, appears to lie straight across the middle of his disk. Rather more than seven years later he is posed as our earth is posed at midsummer, his northern pole is bowed toward the sun, and his equator is seen as a half-oval, curving far south of the middle point of his disk. He passes on from this position, and in seven more years he is placed as our earth is in autumn, with his equator again lying straight across his disk. Then, seven years or so later, he presents the aspect of our earth at midwinter, his equator curved into a half-oval passing far to the north of the middle point of his disk. And, finally, at the end of yet seven years more (or, more exactly, of one complete Saturnian year from the commencement of these changes), he is again as at first. Now, it seems manifest that, if the great cloud-zone which surrounds Saturn, appearing as a nearly white ring, were due to solar action, it would fluctuate in position as these changes proceeded. The very length of the Saturnian year should insure the occurrence of such fluctuations. We have only to inquire what takes place on our own earth, where, though we have nothing comparable with the belt systems of Jupiter and Saturn, we have, nevertheless, over ocean-regions, a sun-raised tropical cloud-band in the middle of the day. This cloud-band *follows the sun*, being equatorial in spring, passing far north of the equator, even to the very limit of the torrid zone, in summer, returning to the equator in autumn, passing to the southern limit of the torrid zone in winter, and returning again to the equator in spring. In fact, this cloud-band as seen from the sun would always cross the middle of the earth's face as a straight line in spring and autumn, and as considerably more than a half-oval, agreeing in position with the tropics of Cancer and Capricorn, at midsummer and midwinter. But nothing of the sort happens in Saturn's case. His equatorial white ring is *really* equatorial at all times, instead of being drawn to his tropics at his midsummer and midwinter seasons. This, in our opinion, is decisive of the origin of this great band. If it were sun-raised, it would obey the sun; but, being raised

by Saturnian action, its position is solely determined by Saturn's rotation, and it therefore remains constantly equatorial.

But next a very strange and, at a first view, incredible circumstance has to be considered in immediate connection with the relations we have been dealing with.

It sounds startling to suggest that *Saturn probably changes at times in size and shape*. Yet the evidence in favor of the suggestion is very weighty. It may briefly be presented as follows:

In April, 1805, Sir William Herschel, *who had hitherto always seen the planet of an oval figure*, found that it presented a strangely distorted appearance. It was flattened as usual at the poles, but also at the equator; accordingly, it had a quadrangular or oblong figure (with rounded corners, of course), its longest diameters being the two which (crossing each other in the middle of the disk) passed from north latitude  $43^\circ$  on Saturn to the same southerly latitude. Or we may otherwise describe the appearances presented, by saying that Saturn seemed *swollen* in both the temperate zones. Herschel found that the same appearance was presented, no matter what telescope he employed, and he tried many, some seven feet, some ten, one twenty, and one forty feet in length. With these telescopes Jupiter presented his ordinary oval aspect. But Herschel is not the only astronomer by whom such appearances have been noticed. On August 5, 1805, Schröter found that Saturn's figure was distorted. Dr. Kitchener says that in the autumn of 1818 he found Saturn to have the figure described by Herschel. The present Astronomer Royal has seen Saturn similarly distorted, and on another occasion *flattened* in the temperate zones. In January, 1855, Coolidge, with the splendid refractor of the Cambridge (U. S.) Observatory noticed a swollen appearance in Saturnian latitude  $20^\circ$ ; yet on the 9th the planet had resumed its usual aspect. In the report of the Greenwich Observatory for 1860-'61, it is stated that "Saturn has *sometimes* appeared to exhibit the *square-shouldered* aspect." The two Bonds, of America, surpassed by few in observing skill, have seen Saturn square-shouldered and have noticed variations of shape. It seems impossible to reject such testimony as this. Nor can it be disposed of by showing that ordinarily Saturn presents a perfectly elliptical figure. It is the essential point of the circumstances we are considering, that they are unusual.

Now, we do not pretend to explain how such changes of shape are brought about. But we would invite special attention to the circumstance that if these changes be admitted as having occasionally occurred (and we do not see how they can be called in question), then the result is only startling in connection with that theory of Saturn's condition which we are here opposing. If Saturn be a globe resembling our earth, then sinkings and upheavals, such as these appearances indicate, must be regarded as involving amazing and most stupendous throes—as in fact absolutely incredible, no matter what evidence may

be found in their favor. But, so soon as we regard Saturn's whole globe as in a state of intense heat, and his belt-system as indicating the continual action of forces of enormous activity, we no longer find any difficulty in understanding the possibility of changes such as Sir W. Herschel, Sir G. Airy, the Bonds, and others of like observing skill, have seen with some of the finest reflecting and refracting telescopes ever constructed by man. Nay, we may even go further, and find in solar phenomena certain reasons for believing that Saturn's globe would be subjected to precisely such changes.\* It appears to have been rendered extremely probable by Secchi and others, that our sun's globe varies in dimensions under the varying influences to which he is subjected. At the height of the spot-period the sun seems to be reduced in diameter, while his colored sierra is deeper, and the red prominences are larger than usual, the reverse holding at the time when the sun has no spots or few. Of course this is not understood as implying a real change in the quantity of solar matter, but only as indicating the varying level at which the solar cloud-envelope lies. We may safely assume that these changes, which correspond to the great spot-period, affect chiefly the spot-zones which lie in the parts of the sun's globe corresponding to our temperate zones; but, for the same reasons that the sun's globe is perfectly spherical so far as measurements can be depended upon, namely, because of its relatively slow rotation—such differences would be too slight to be measurable. Regarding Saturn, then, as we have already been compelled to do for other reasons, as resembling the sun so far that he is in an intensely heated condition, we see grounds for believing that *his* temperate zones would be exposed to variations of level (cloud-level), which at times might be very considerable, and thus discernible from our earth. For, owing to his rapid rotation on his axis, all such effects would be relatively greater than on a slowly rotating orb like the sun; and in fact we recognize this distinction in the great compression of Saturn's globe. Moreover, if we regard the waxing and waning of the solar spots as associated with the motions of the members of the sun's family, we can well understand that the members of Saturn's family, which lie so much nearer to him compared with his own dimensions, should produce more remarkable effects.<sup>1</sup> But, whether this be so or not, it is certain

<sup>1</sup> It must not be understood that in thus speaking we countenance the theory that either the planets produce the sun-spots, or the satellites of Saturn effect the remarkable changes we have been dealing with. The real causes of all solar phenomena must be sought in the sun's own globe; and Saturnian phenomena are in the main, we have little doubt, produced by Saturnian action. But even as our moon (probably) exerts an influence on the occurrence of earthquakes and volcanoes, *not* by her own attraction directly, but by affecting the balance between terrestrial forces, so it may well be that the planets indirectly affect the sun's condition, and that the Saturnian satellites even more effectually act upon Saturn. It would be extremely interesting to inquire whether any connection can be traced between the changes of the Saturnian belts and the motions of his satellites. Or the inquiry might be more readily and quite as effectually applied to Jupiter and his system.

that, whereas there is nothing inexplicable or even very surprising in supposing that Saturnian cloud-layers, resulting from the action of intense Saturnian heat, alter greatly at times in level, the observations we have described become altogether inexplicable, and cannot, in fact, be rejected, if we adopt the theory that Saturn resembles the earth on which we live.

It may be asked whether Jupiter, to which planet the same reasoning may be applied, has ever shown signs of similar changes. To this it may first be replied, that we should not expect Jupiter to be affected to the same degree, simply because the chief disturbing causes—his satellites and the sun—are always nearly in the same level, owing to the peculiarity in Jupiter's pose to which attention has already been directed. But, secondly, such briefly-lasting changes as we might expect to detect have occasionally been suspected by observers of considerable skill; and among others by the well-known Schröter, of Lillenthal. Such changes have consisted, for the most part, merely in a slight flattening of a part of Jupiter's outline. But on one occasion a very remarkable phenomenon, only (but very readily) explicable in this way, was witnessed by three practised observers—Admiral Smyth, Prof. Pearson, and Sir T. Maclear—at three different stations. Admiral Smyth thus describes what he saw: "On Thursday, June 26, 1828, the evening being extremely fine, I was watching the second satellite of Jupiter as it gradually approached to transit Jupiter's disk. It appeared in contact at about half-past ten, and for some minutes remained on the edge of the disk, presenting an appearance not unlike that of the lunar mountains coming into view during the moon's first quarter, until it finally disappeared on the body of the planet. At least twelve or thirteen minutes must have elapsed, when, accidentally turning to Jupiter again, to my astonishment I perceived the same satellite *outside the disk!* It remained distinctly visible for at least four minutes, and then suddenly vanished!" For our own part, we can conceive of no possible explanation of this remarkable phenomenon, unless it be admitted that the change was in the apparent outline of Jupiter. Of course, to suppose that even a cloud-layer rose or fell, in a few minutes, several thousand miles (about 8,000, if the stated times be correct), is as inadmissible as to suppose the solid crust of a globe to undergo so vast a change of level; but nothing of this sensational description is required. All that would be necessary would be, that an upper cloud-layer should for a few minutes be dissipated into vapor, either by warm currents, or more probably by a temporary increase of the heat supplied by Jupiter's fiery globe within the cloud-envelopes, and that a few minutes later the clouds should form again by the condensation of the vaporized matter. The changes in the aspect of the Jovian belts are often sufficiently rapid to indicate the operation of precisely such processes.

Associated with such phenomena as we have mentioned is the evi-



dence we have as to the brightness of Saturn and Jupiter. If these planets were perfectly cloud-encompassed, we should expect them to shine much more brightly than earthy or rocky globes of equal size, similarly placed, and surrounded only with a tenuous atmosphere. In fact, we should expect the planets, if cloud-encompassed, to shine about four times as brightly as though they were constituted like our moon. They would in that case, however, be white planets, not only as seen by the naked eye, but when examined with the telescope. In point of fact, they shine, according to the very careful measurements of Zöllner, about as brightly as though they *were* perfectly cloud-enveloped; but they are neither of them found to be white under telescopic scrutiny. Bond, of America, says, indeed, that Jupiter shines *fourteen* times as brightly as he would if constituted like the moon; and though this is a surprising result, and would imply that some portion of Jupiter's light is certainly inherent, it is well to notice that it is confirmed by De La Rue's photographic researches; for he found that a photographic image of the moon can be taken in about two-thirds of the time required in Jupiter's case, whereas the moon should require but a twenty-fifth of the time required by Jupiter, if her reflecting power were equal to his, since Jupiter is five times as far away from the sun. It would follow from this that Jupiter shines nearly seventeen times as brightly as he would if he were constituted like the moon. Taking the lowest estimate, however, we find that both Saturn and Jupiter shine much more brightly than planets of equal size and similarly placed, but having a surface formed of any kind of earth or rock known to us. And, taking into account the well-marked colors of these planets, it follows as an almost demonstrated fact that each shines with no inconsiderable portion of inherent light.<sup>1</sup>

So soon as we view Saturn as a globe intensely heated, and the scene of forces of enormous energy, we are compelled to dismiss the idea that he is the abode of life. But, singularly enough, this conclusion, which was rejected by Brewster as rendering apparently unintelligible the existence of so large and massive an orb, girt about by a system so complex and beautiful, does in reality at once present, in an explicable aspect, not merely the vast bulk of Saturn himself, but the scheme over which he bears sway; for, as it seems to us, not the least of the objections against the theory that Saturn is an inhabited world, is found in the useless wealth of material exhibited, on that

<sup>1</sup> I might take, as equally convincing proof of the intensely heated condition of these giant planets, the fact that the shadows of the nearer satellites, which theoretically should be black, have *sometimes* been seen to be gray, and never appear to be much darker than the fourth satellite in transit. And, as sufficient proof of the great depth of Jupiter's atmosphere, I could take the fact that sometimes two shadows have been seen, both belonging to the same satellite. However, it would require more space than can here be spared to show the force of these facts. I remind the reader that whatever is proved respecting the condition of Jupiter, may be regarded as rendered probable of his brother giant, Saturn.



supposition, in his ring-system and family of satellites. It is very well to grow rapturous, as many besides Brewster and Chalmers have done, over the beauty of the Saturnian skies, illuminated by so many satellites and by the glorious rings; and it is very proper, no doubt, for those who so view Saturn's system, to dwell admiringly on the beneficence with which all this abundance of reflected light has been provided, to make up to the Saturnians for the small amount of light and heat which they receive from the sun. But, unfortunately for this way of viewing the matter, the satellites and rings do not by any means subserve the purposes thus ascribed to them. Even if all the satellites could be full together, they would not supply a sixteenth part of the light which we receive from our full moon; and they cannot even appear very beautiful when we consider that the apparent brightness of their surface can be but about one-ninetieth of the brightness of our moon's. As for the rings, so far from appearing to be contrived specially for the advantage of Saturnian beings, these rings, if Saturn *were* inhabited, would be the most mischievous and inconvenient appendages possible. They would give light during the summer nights, indeed, when light was little wanted, though even this service would be counteracted by the circumstance that at midnight the enormous shadow of the planet would hide the greater part of the rings. But it is in winter that the rings would act most inconveniently; for then, just at the season when the Saturnians would most require an additional supply of light and heat, the rings would cut off for extensive regions on Saturn the whole of the solar light and heat which would otherwise be received. Dr. Lardner was quite mistaken in supposing (after a cursory examination of the mathematical relations involved) that the eclipses so produced would be but partial. His object was excellent, since he sought to show that "the infinite skill of the Great Architect of the universe has not permitted that the stupendous annular appendage, the uses of which still remain undiscovered, should be the cause of such darkness and desolation to the inhabitants of the planet, and such an aggravation of the rigors of their fifteen years' winter," as would result from eclipses lasting many months or even years in succession. But we must not endeavor to strengthen faith in the wisdom of the Almighty by means of false mathematics. So soon as the subject is rigorously treated, we find that Sir John Herschel was quite right in his original statements on this subject. The present writer published, in 1865, a tabular statement of the length of time during which (according to rigid mathematical calculations) the eclipses produced by the rings last in different Saturnian latitudes. The following quotation from the work in which this table appeared will serve to show that the partial daily eclipses conceived by Lardner are very far from the truth, or rather are only a part, and a very small part, of the truth: "In latitude 40° (north or south), the eclipses begin when nearly three

years have elapsed from the time of the autumnal equinox. The morning and evening eclipses continue for more than a year, gradually extending until the sun is eclipsed during the whole day. These total eclipses continue to the winter solstice, and for a corresponding period after the winter solstice; in all, for six years, 236 days, or 5,543 Saturnian days. This period is followed by more than a year of morning and evening eclipses. The total period during which eclipses of one kind or another take place is no less than eight years, 293 days. If we remember that latitude  $40^\circ$  on Saturn corresponds with the latitude of Madrid on our earth, it will be seen how largely the rings must influence the conditions of habitability of Saturn's globe, considered with reference to the wants of beings constituted like the inhabitants of our earth."<sup>1</sup> In the presence of such facts as these, we may follow Sir John Herschel in saying that "we should do wrong to judge of the fitness or unfitness of the arrangements described, from what we see around us, when perhaps the very combinations which convey to our minds only images of horror may be in reality theatres of the most striking and glorious displays of beneficent contrivance." But we do well to exercise our minds in inquiring how this may be; and, as it appears to us, the views which have been advocated in this essay at once afford an answer to this inquiry. We are taught to see in the Saturnian satellites a family of worlds dependent on him, in the same way that the members of the solar family are dependent on the sun. We see that, though the satellites can supply Saturn with very little light, he can supply them, whether by reflection or by inherent luminosity, with much. And, lastly, we see that the ring-system (which has been shown to consist of a multitude of small bodies, each traveling in its own course), while causing no inconvenience by eclipsing parts of Saturn, may not improbably serve highly-important purposes by maintaining an incessant downfall of meteoric matter upon his surface, and thus sustaining the Saturnian heat, in a manner not unlike that in which it is now generally believed that a portion at least of the sun's heat-supply is maintained by the fall of interplanetary meteors. In fine, we see in Saturn and his system a miniature, and a singularly truthful miniature, of the solar system. In one system, as in the other, there is a central orb, far surpassing all the members of the system in bulk and mass; in each system there are eight orbs circling around the central body; and, lastly, each system exhibits, close by the central orb, a multitude of discrete bodies—the zodiacal light in the solar system, and the scheme of rings in the Saturnian system—doubtless subserving important though as yet unexplained purposes in the economy of the systems to which they belong.—*Cornhill Magazine*.

<sup>1</sup> As this passage has been quoted nearly *verbatim*, and without any sort of acknowledgment, in a compilation on "Elementary Astronomy," recently published, the present writer, that he may not be suspected of plagiarism, ventures to point out that it is not he who is the borrower.

## THE PHENOMENA OF HEREDITY.

BY FERNAND PAPILLON.

TRANSLATED BY J. FITZGERALD, A. M.

IN human science there is many a ground of self-satisfaction and of pride for the mind, but there are at the same time reasons for humility and bitter disappointment. Notwithstanding the strenuous efforts and the protracted meditations of the legions of investigators who have gone before us, Nature still has abysses dark and deep before which the keenest sight becomes blindness, courage changes into fear, and assurance into despondency. When we strive to throw some light into these mysterious gulfs, the light does but reveal to us the spectres of our own ignorance, and all that we carry away from the vain attempt is a renewed consciousness of our weakness and indigence. It were wise for us to carry away something more, viz., a useful lesson. Indeed, there is nothing that is better fitted to teach us modesty and patience, to cool down presumptuous ardor, and to put to shame overweening temerity, than the study of those phenomena which Providence would seem to have devised for the express purpose of baffling man's curiosity. And yet many there are who pretend to ignore the wonderful and complex phenomena which occur in regions inaccessible to sight or sense, and who stubbornly question the existence of invisible activities and insensible forces. Such is the fatal skepticism against which we must cite the testimony of the sphinxes that occupy our attention now. The lesson is all the more impressive, inasmuch as, by strange contrast, these questions, so refractory to all manner of theoretic explanation, are precisely the ones with which our empirical acquaintance is fullest. Here a knowledge of effects seems in no wise to pave the way to a knowledge of causes.

These remarks have a special application to the subject of heredity. It is an ascertained fact that the ovum contains in its seemingly homogeneous substance not only the anatomical structure of the individual that is to spring from it, but also his temperament, character, aptitudes, sentiments, and thoughts. The parents place in this molecule the future of an existence which is nearly always the counterpart of themselves physiologically, oftentimes pathologically, and in many instances psychologically. Such are the results of the latest studies into this amazing vital economy; and these we purpose laying before our readers.

Heredity is that biological law in virtue of which living beings tend to transmit to their descendants a certain number of their own characteristic traits. It is a very nice question to decide whether we must class under heredity the transmission of the anatomical forms

and physiological functions which constitute the species. At all events, it is plain that in this case the parents are completely and absolutely repeated in the children. Were this not so, there would be no species, but only successions of beings without any relations between them save that of generation. Within the historic limits of experience, the continuous reproduction of specific characters, always identical, or, in other words, the permanent integrity of species, is a fact almost beyond question. The distinctive characters of races and of varieties are transmitted with less regularity and fixity, and it is precisely on the various transformations that these may undergo from one generation to another that a famous school of naturalists rest when they would prove, in a more or less extended sense, the transformation of organisms in time. But more irregular still and more variable is the repetition of those characters which, as being less general than those of a species or a race, may be regarded as belonging to the individual. Thus, in proportion as the characters become more particular and more special, the more are they released from the law of heredity, and the greater is the probability that the children will differ from the parents. Still, observation—an observation as ancient as the human race itself—shows that these characters, though personal, may be transmitted by generation. But within what limits, and under what conditions? This we have to inquire into with all circumspection, for there is no other subject in which one is so much in danger of making missteps, and of slipping on dangerous inclines.

Heredity is especially noticeable in the continuity of physiological and pathological conditions. It is very clearly evident in the expression and features of the physiognomy. This was observed by the ancients; hence the Romans had their *Nasones*, *Labeones*, *Buccones*, *Capitones*, etc. (*Big-nosed*, *Thick-lipped*, *Swollen-cheeked*, *Big-headed*). Of all the features, probably the nose is best preserved by heredity: the Bourbon nose is famous. Heredity also manifests itself by fecundity and longevity. In the old French noblesse there were several families which possessed high procreative vigor. Anne de Montmorency, who, at the age of over sixty-five years, could still, at the battle of St. Denis, smash with his sword the teeth of a Scotch soldier who was giving him the death-blow, was the father of twelve children. Three of his ancestors, Matthew I., Matthew II., and Matthew III., taken all together, had eighteen, and of these fifteen were boys. The son and grandson of the great Condé had nineteen between them, and their great-grandfather, who lost his life at Jarnac, had ten. The first four Guises reckoned in all forty-three children, of whom thirty were boys. Achille de Harley had nine children, his father ten, and his great-grandfather eighteen. In some families this fecundity endured through five or six generations. The average length of life depends on locality, diet, stage of civilization, but individual longevity appears

to be completely freed from these conditions. It is observed among those who lead the most laborious lives, as well as among those who take the greatest care of their health, and it seems to be connected with some inner power of vitality transmitted to individuals from their forefathers. So well known is this fact that, in England, life-assurance companies receive from their agents statements as to the longevity of the applicants' ancestors. In Turgot's family, the age of fifty-nine was very rarely exceeded, and the man who made that family illustrious had a presentiment, so soon as he had reached fifty, that the close of his life was not distant. Albeit he had all the appearances of good health and of great vigor of temperament, still from that time forward he held himself ready for death, and, in fact, did die at the age of fifty-three.

Heredity often transmits muscular strength and sundry other motor activities. In ancient times there were families of athletes, and the English have families of boxers. The recent researches of Mr. Galton, as to wrestlers and oarsmen, show that the winners in the contests in which these men engage generally belong to a few families in which agility and dexterity are hereditary. Suppleness and grace in dancing are also transmitted, as is shown in the case of the celebrated Vestris family. The same is to be said with regard to various peculiarities of voice, such as stammering, nasality, and lisping. There are several families who are naturally singers. Children born of babbling parents are themselves babblers by birthright. Dr. Lucas cites the case of a servant-maid whose loquacity knew no bounds. She would talk to people till they were ready to faint; but she would also talk to animals and to inanimate things. Even when she was quite alone she talked to herself aloud. She had to be discharged; "but," said she to her master, "I am not to blame; it all comes from my father. He had the same fault, and it drove my mother to distraction; and his father was just as I am."

The heredity of anomalies of organization has been demonstrated in several instances. One of the most singular of these is the case of Edward Lambert, whose whole body, except the face, the palms of the hands, and the soles of the feet, was covered with a sort of shell, consisting of horny excrescences. He was the father of six children, all of whom presented the same anomaly at the age of six weeks. The only one of them who lived transmitted the peculiarity to all his sons, and this transmission, passing from male to male, persisted through five generations. Mention is also made of the Colburn family, where the parents for four generations transmitted to the children what is called sexdigitism, i. e., hands and feet with six digits each. Albinism, halting, hare-lip, and other anomalies, are in like manner reproduced in the progeny. It has been observed that purely individual habits have a like tendency to repeat themselves. Girou de Buzareingues informs us that he knew a man who, when abed, was wont to lie on his back

with the right leg crossed on the left. One of his daughters had the same habit from birth; she constantly assumed that position in the cradle, notwithstanding the resistance offered by the swaddling-bands. The same author assures us that he has oftentimes noticed in children other habits no less extraordinary, which they must have received from their parents, and which cannot be attributed either to imitation or to education. Darwin gives another instance: A child had the odd habit of setting its fingers in rapid motion whenever it was particularly pleased with any thing. When greatly excited, the same child would raise the hands on both sides as high as the eyes, with the fingers in rapid motion, as before. Even in old age he experienced a difficulty in refraining from these gestures. He had eight children, one of whom, a little girl, when four years of age, used to set her fingers going and to lift up her hands after the manner of her father. Finally, heredity has been observed in handwriting. There are families in which the special use of the left hand is hereditary. Various peculiarities of sensorial conditions are transmitted in a similar way. Nearly all the members of the Montmorency family were affected with an incomplete strabismus, which used to be called the Montmorency look. The incapacity to distinguish between different colors is notoriously hereditary. The distinguished English chemist, Dalton, and two of his brothers, were thus affected, and hence the affection itself received the name of Daltonism. Deafness and blindness are sometimes hereditary, though not often, and deaf-muteness still more rarely. Some curious instances are given of the transmission of certain perverse tastes. Lucas, according to Zimmermann, relates the following: A man in Scotland was possessed of an irresistible desire of eating human flesh. He had a daughter. Although removed away from her father and mother, who were sent to the stake before she was one year old, and although brought up among respectable people, this girl, like her father, succumbed before her strange craving for human flesh. This is clearly a case allied to insanity.

Insanity is, beyond all doubt, transmitted by heredity. Among 1,375 lunatics Esquirol found 337 cases of hereditary transmission. Guislain and other physicians, on a rough estimate, represent the patients affected with hereditary insanity as one-fourth of the total number of the insane. Moreau, of Tours, and others, hold that the proportion of the former is still greater. The heredity of insanity does not imply merely direct transmission of insanity (alienation), properly so called; hysteria, epilepsy, chorea, idiocy, hypochondria, may result from insanity, and, *vice versa*, they may produce insanity. In passing from one generation to another, these various neuroses (nervous affections) are in some way transformed into one another.<sup>1</sup> Herpin, of Ge-

<sup>1</sup> Simple alcoholic intoxication may pass into profound neuroses. Children conceived during an acute attack of intoxication are often epileptic, insane, idiots, etc. These facts were observed long ago. A law of Carthage forbade all beverages except water on the



neva, has found, in the ancestry of 243 epileptics, seven epileptics, 21 insane, and 27 individuals who had suffered from cerebro-spinal affections. Georget, from numerous observations made at the Salpêtrière, came to the conclusion that hysterical women have always near relations who are hysterical, epileptical, hypochondriac, or insane. Moreau calls attention to the "prodigious quantity" of morbid nervous conditions to be found in the ancestry of idiots and imbeciles. A single fact will give the means of judging of the varied and odd complications occurring in the hereditary transmission of neuroses. Dr. Morel attended four brothers belonging to one family. The grandfather of these children had died insane, their father had never been able to continue long at any thing, their uncle, a man of great intellect, and a distinguished physician, was noted for his eccentricities. Now, these four children, sprung from one stock, presented very different forms of physical disorder. One of them was a maniac, whose wild paroxysms recurred periodically; the disorder of the second was melancholy madness; he was reduced by his stupor to a merely automatic condition. The third was characterized by an extreme irascibility and suicidal disposition. The fourth manifested a strong liking for art, but he was of a timorous and suspecting nature.

Scrofula, cancer, tubercular consumption, syphilis, gout, arthritis, tetter, and, in general, all those chronic constitutional affections which are called diatheses or cachexias, are very often transmitted from parent to child. The heredity of these morbid states is almost as frequent and as well defined as that of the neuroses. We may also affirm the heredity of skin-diseases, and especially of psoriasis, although in this case heredity is of rarer occurrence.

The evolution of these hereditary maladies is extremely interesting and dramatic. Planted in the children's system as germs, or as mere predispositions, they are sometimes destroyed, beyond the possibility of returning, by a multitude of favorable conditions and precautions: in other instances, they begin at once their fatal work of destruction; or, again, they lie hidden for years, reappearing at length, remorseless and terrible, under the influence of sundry exciting causes. Thus age, sex, temperament, practices, habits, hygiene, surrounding conditions, act a part in the development of hereditary morbid activities. Insanity is rare in childhood, and epilepsy most commonly makes its appearance in youth. Hysteria, scrofula, rachitism, and tubercle, appear in childhood and in youth, while gout, gravel, calculus, alopecia, and cancer, are hereditary states of the adult. Women are more liable to insanity, epilepsy, and hysteria, than men; but men, on the other hand, are far oftener than women attacked by gout, gravel, and calculus. The ner-

day of marital cohabitation, and Amyot says that "drunkenness genders naught that is sound." Recent accurate observations have shown that the child that is conceived in a fit of alcoholic delirium, though the latter be only transitory, carries forever the ineffaceable marks of a more or less profound degeneracy.

vous temperament favors neuroses; the lymphatico-sanguine, arthritis and tetter; and the lymphatic, scrofula. The changes occurring in the physiological equilibrium of an individual have a very definite action on the movements and aspects of constitutional affections. Thus, insanity oftentimes appears following menstruation, pregnancy, or childbirth; and, in like manner, epilepsy and hysteria manifest themselves at the first appearance of the signs of puberty. Education and habits exercise a similar influence. Harsh usage and excessive severity, as also complete lack of discipline and watchfulness, have often deplorable effects on the brain of children. Alcoholic excesses and high living are extremely injurious to those whose parents had the gout or the gravel, just as squalor and bad air decimate those who have in themselves the germs of consumption.

This much at least is certain, that the fatal character of hereditary disease is a great and mournful fact, of which they alone are fully and sadly conscious who have daily to witness its consequences. One must see the premature infirmity, the long-continued suffering, the irreparable catastrophes, the slow, cruel agonies, to which parents oftentimes condemn their children, to form a judgment of the power possessed by the demon of disease which lurks in the depths of their being. We must read the authors who have treated these questions, and especially the great alienists of France, if we would learn what a mysterious and baleful energy is oftentimes brought into the world by the babe as it opens its eyes to the light of day—the poor, innocent, puny creature, which, for this brief moment of illusion, is the object of unbounded joys and blessings, and bright hopes!

In short, we may say that the hereditary transmission, whether of individual peculiarities of anatomical structure and of temperament, or of liability to such and such a morbid condition—and the same holds good for certain bodily aptitudes—is a very frequent, though not constant, phenomenon in animals and in man.

Hereditary transmission of individual peculiarities of the mental or affectional kind, and of aptitudes for such and such speculative or moral activities, is also a phenomenon which may be observed, though more rarely than that just mentioned. When we go through the series of instances and authorities got together and cited by certain writers, we are struck, it is true, by the apparent force of their arguments, and one is ready to assign to heredity a large share in the development of intellect and character, in the genesis of the thinking individual. We do not see, we forget, the immense number of facts which stand on the other side. The illusions of these mirages have not been useless, seeing that they have led to researches of great interest; but they would be dangerous if they were to be taken by the public as demonstrating the conclusions drawn by some writers. We will state, in brief, the substantial benefits accruing from the researches, and we will then try to refute the conclusions.

According to Galton, the memory was so notable a faculty in the family of the celebrated English Hellenist, Porson, as to have passed into a by-word, *the Porson memory*. Lady Hester Stanhope, she whose life was so full of adventure, gives, as one among many points of resemblance between herself and her grandfather, her retentive memory. "I have my grandfather's gray eyes," said she, "and his memory of places. If he saw a stone on the road, he remembered it: it is the same with myself. His eye, which was ordinarily dull and lustreless, was lighted up, like my own, with a wild gleam whenever he was seized with passion." The imaginative and creative faculties, those which play the chief part in art and in poetry, are sometimes transmitted from father to son. Galton, in the work he published four years ago ("Hereditary Genius"), and Ribot, in his recent book, give long lists of painters, poets, and musicians, in order to show the part played by heredity in the genesis of these artists' talents. There are in these lists many instances in which this influence of heredity is indubitable, but there are far more in which it is very questionable indeed. Thus, these authors see the influence of heredity in the poetic genius of Byron, Goethe, and Schiller, because they find in the ancestors of these poets certain passions, vices, or qualities—just as though these peculiarities of character could determine poetic genius. The fact is, these lists do not show us any great poet who received his faculties from his ancestors. We do there find that a great poet is sometimes the father of mediocre poets—which is a different thing. The heredity of aptitudes for painting is better established: in a list of 42 celebrated painters, Italians, Spaniards, and Flemings, Galton shows that 21 had illustrious ancestors. The names of Bellini, Caracci, Teniers, Van Ostade, Mieris, Vandervelde, and Vernet, will suffice to prove that there are families of painters. In the family of Titian we find nine painters of merit. The history of music presents instances still more striking. The Bach family took its rise in 1550, and became extinct in 1800. Its head was Veit Bach, a baker at Presburg, who used to seek for relaxation from labor in music and song. He had two sons, who commenced that unbroken series of musicians of the same name, who, for nearly two centuries, overran Thuringia, Saxony, and Franconia. They were all organists, church singers, or what is called in Germany city musicians. When they became too numerous to live all together, and the members of this family were scattered abroad, they resolved to meet once a year, on a stated day, with a view to keep up a sort of patriarchal bond of union. This custom was kept up until nearly the middle of the eighteenth century, and oftentimes more than 100 persons bearing the name of Bach, men, women, and children, were to be seen assembled. In this family are reckoned 29 *eminent* musicians, and 28 of a lower grade. Mozart's father was second capellmeister to the prince-bishop of Salzburg. Beethoven's father was tenor in the chapel of the Elector of Cologne: his grandfather had

been chanter, and then master in the same chapel. Rossini's parents played music at fairs.

We find almost as effectual and continuous an intervention of heredity in the transmission of passions and sentiments of a very different order—those which incline to vice. The liking for strong drink, habits of debauch, a passion for gambling, acquire in some persons a degree of force which can be accounted for only by some fatal organic predisposition derived from their ancestors. "A lady with whom I was acquainted," says Gama Machado, "and who possessed a large fortune, was possessed of a passion for gambling, and passed whole nights at play: she died young, of a pulmonary complaint. Her eldest son, who was in appearance the image of his mother, had the same passion for play. He died of consumption, like his mother, and about the same age. His daughter, who resembled him, inherited the same tastes, and died young." The heredity of a disposition for theft, rape, murder, and suicide, has been proved in several instances.

In proportion as you rise above the purely physiological and pathological regions to those where the mind's activity takes a larger part, heredity is found to lose force and constancy of action. There have been families of scientists—the Cassinis, Jussieus, Bernouillis, Darwins, Saussures, Geoffroys, Pictets. In literature and erudition, the names of Estienne and Grotius, and others, occur. The Mortemarts were famous for their wit. A genius for statesmanship or for generalship has sometimes been perpetuated for several generations in certain families. On the whole, these cases of the transmission of psychological qualities are not frequent. Their being so carefully noted and so set in relief is apparently due to the fact that they are not of common occurrence; and besides, in many of these cases, education had probably more to do than heredity.

Some years ago there appeared a book entitled "Phrenyogenie," in which is to be found, side by side with many chimerical and paradoxical statements, one reflection worthy of attention, and this all the more because it takes account of a peculiarity which appears to have escaped the physiologists hitherto. The author of that book, M. Bernard Moulin, strives to prove that children are living *photographs* of their parents, as they were at the moment of conception. According to him, the parents transmit to the children the tastes and aptitudes, the spontaneous or the elicited exercise of which was then at the maximum. The broad conclusions which Moulin draws from his researches, as to the art of procreating superior children, may perhaps call forth a smile, but the facts cited by him in support of his views are curious. Here are a few of them: Nine months before the birth of Napoleon I., Corsica was all in confusion. The celebrated Paoli, at the head of an army of citizens which he himself had raised, was endeavoring to put an end to the civil war, and to prevent an invasion by foreigners. Charles Bonaparte, his aid-de-camp and secretary, displayed great

courage at the side of his commander. The young officer had with him his wife, Letitia Ramolino, a woman of Roman beauty, and of a strong and masculine character. Napoleon was conceived in his tent, on the eve of a battle, at the distance of two paces from the batteries which faced the enemy. Robespierre was born in 1758, the year which saw Damiens tortured and dragged about the Place de Grève, a year of war, of famine, and of discontent. His father was an attorney, and an insatiable reader of the "*Contrat Social*." Peter the Cruel, King of Castile, was the son of Alfonso XI., who was ever at variance with his wife. Scandalous scenes of anger, jealousy, and rage, continually disturbed the royal household, and the fruit of the commerce of this wedded pair was Peter the Cruel, a monster of ugliness, physical and moral. History shows to us the parents of Raffaele both devoted to the art of painting. The wife, a true Madonna, delighted in subjects where grace and piety prevailed; the husband, a great dauber, preferred strength for his part.

M. Ribot, in the remarkable work which he has just written on the subject of heredity, investigates the laws of this mysterious influence, which he regards as a sort of habit, an eternal memory. These laws are little more than a statement of the habitual directions of hereditary impulsions. Sometimes heredity passes from the father to the daughter, from the mother to the son; again the child inherits from both parents. Finally, it often happens that the child, instead of resembling his immediate parents, resembles one of his grandparents, or some remote member of a collateral branch of the family. This is called *atavism*. This fact was well known to the ancients. Montaigne regarded it with wonder. "Is it not astonishing," says he, "that this drop of seed from which we are produced should bear the impression not only of the bodily form, but also of the thoughts and the inclinations of our fathers? Where does this drop of water keep this infinite number of forms? and how does it bear these likenesses through a progress so hap-hazard and so irregular that the great-grandson shall resemble the great-grandfather, the nephew the uncle?" Montaigne's wonder has good ground; nor do we to-day know any better than those of the sixteenth century the causes of these strange transmissions.

Such are the facts. In vain would we multiply them, or comment upon them, to change their character. Cases of heredity will never be, in the domain of physiology, any thing more than exceptions, as compared with the cases which make against heredity. But now, if these are only exceptions, by what right shall any man set up heredity as the general law of the development of intellectual activity, or affirm that heredity is here the law, non-heredity the exception? Ribot accumulates the subtlest of arguments to strengthen this singular proposition, but he is wasting his time, wasting his talent. Explain as you will how the heredity of intellectual aptitudes is almost ever overcome

by antagonistic or disturbing causes, the fact remains that heredity has not the upper hand. With what ingenious reasons soever you console yourself on seeing the ideal sovereignty of heredity brought down, in matter of fact, to a very low grade of authority, still heredity is not helped. In a word, if non-heredity has in fact a far wider empire than heredity, the question arises, Why does M. Ribot adopt a formula which implies the contrary?

Besides, does not the history of the development of civilization itself show existing in man the preponderant force of an eternal tendency to metamorphosis, to innovation, and to change? Fixedness of thoughts and immobility of habits were, it is true, the law of primitive peoples, as they still are of savage tribes; but then there is nothing to show that this is owing to heredity. This more or less protracted repetition of identical societies should rather, we think, be attributed to the strong and irresistible instinct of imitation and to the profound respect entertained for rites and customs established by religion. Among such peoples the future is like the present, and the present like the past, because the same inflexible rule, the same authority, and the same tyrannical superstition are imposed on them all. Nothing possesses strength or obtains respect except through tradition, and tradition among such people is only the revered memory of the will of the mysterious powers, manifested in days of yore. When the English would have the Hindoos take a part in road-building and the hygienic improvement of their country, they have still to show that the usefulness of such enterprises was understood by the most ancient Brahmans—so hard is it for this old race to conceive of a law which should be obligatory without being traditional.

However that may be, and whatever part heredity may act here, certain it is that this part is not important, since this singular homogeneity of primitive races, instead of being maintained and growing stronger, does, sooner or later, give place to diversity. Every people is in turn invaded by a force at once capable of acting counter to its hereditary influences, and of releasing it from the iron yoke of antique customs. It was in Greece that about 3,000 years ago the first movement of this force brought about what Goethe calls "the liberation of humanity." Since that day the crossings of distinct races, the many new wants, and the various inventions to which they have given rise, and the ideas which men, owing to their more and more intimate contact with Nature, have conceived, have set in the place of primitive simplicity a multiple and irresistible variability, as the present state of the world clearly shows.



## THE SHOVEL-NOSED SHARK.

BY LADY VERNEY.

THE following sketch from Nature (Fig. 1) represents the jaw of a young shark—a tender innocent, indeed, for, if his life had not been cut short by cruel Fate, he would have attained to the dignity of nine rows of teeth, instead of the poor five which, as you may see inside the mouth, this little victim had been obliged to put up with. A shark's age is counted by the number of rows—and his jaws are the most awful engine of destruction which exists in the animal world: the best possible means that could be devised to seize, to cut and tear, and finally to hold fast any slippery subject, though of no use to chew or masticate.

Still there seems a superfluity of naughtiness in this array of edges and serrated points, set thus, one range following up another, as shown in Fig. 2. What *could* he want with five rows of teeth? It is almost dangerous to run one's finger over them; the points are like knives, the jagged edges along the finely-modulated curves of each three-cornered tooth are so keenly sharp.

There is a sort of hinge in the middle of both upper and lower jaw, and from this centre the teeth point different ways, gradually diminishing to a mere root. Each is a brightly polished piece of ivory, and each little jag of the graduated saws is exquisitely finished, and varies according to its position. The mouth in question only measures nine and eleven inches across, and is about two feet round, but in a full-grown monster the jaws are wide enough to pass over a man's shoulders without touching them. The snout is rounded, with very small eyes almost at the top of his head.

The shark is the scavenger of the sea, the equivalent of the hyena on land, and he swallows whole whatever offal is flung overboard from the ships—bolting it without any action of the teeth, unless when his prey is too large to go conveniently down his throat, and he breaks it up as it passes.

The stomach-coats are extremely strong, and some action seems to go on in it to prepare the food for the gastric juice, as a substitute for the mastication with which other warm-blooded animals reduce it to a pulp in their mouth.

He is so fearless in his voracity, and follows a ship so pertinaciously, that his habits are better known than most of the sea-denizens, and familiarity does not certainly in this instance breed either respect or affection.

With the passengers on board the merchant-vessels to and from Australia, shark-fishing is a favorite pastime. One of these, lately

caught, was twenty feet long. "Our ship was at anchor, and I was holding a line over the side, when the rope began to quiver. I felt that I had hooked a large fish, and, pulling it cautiously, a large shark came to the surface. I called out loudly, when all the passengers came to my help. He struggled, however, so violently, lashing the water with his tail, and trying to bite the hook asunder, that we were obliged to keep dipping his head under water, and then haul him up two or three feet so that the water ran down into his stomach. We went on repeating this till he was nearly drowned, then sending a running bowline down the rope by which he was caught, and making it taut under his hindermost fin, we clapped the line round the steam-winch, and turned the steam on. Some then hauled his tail up, while all available hands dragged at the other line which held his

FIG. 1.

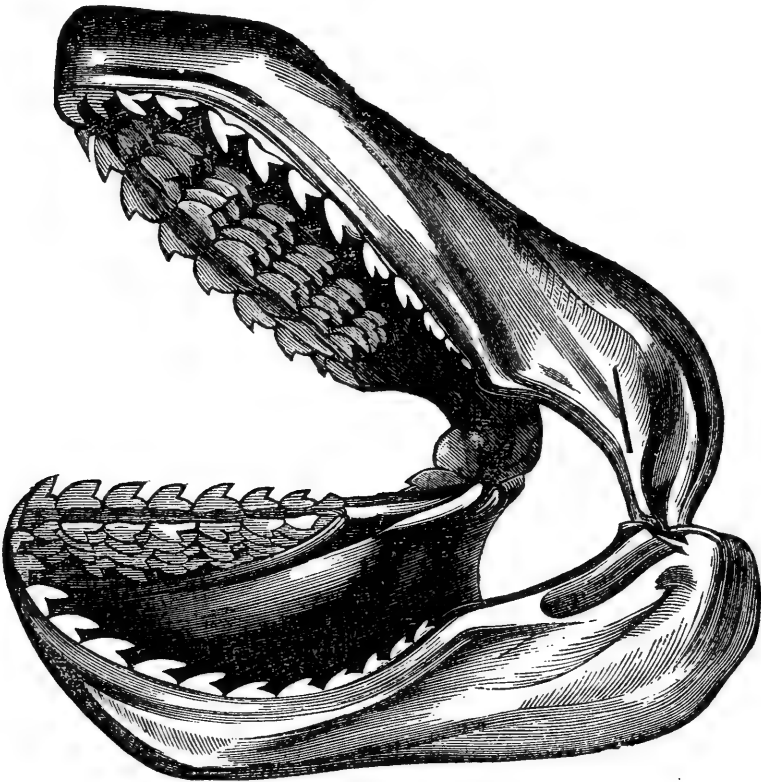

THE JAW OF THE INFANT SHARK.

head. As soon as we got him on board, he sent about three feet of the ship's bulwarks out by a lash of his tremendous tail—which was cut off by the boatswain with a hatchet, while a dozen of us with bowie-knives finished him and opened his maw. Inside we found six large snakes, two dozen lobsters, two empty quart-bottles, a sheepskin and horns, and the shank-bones of beef which the cook had thrown overboard two days before. The liver filled two large wash-deck tubs, and when the cook melted it down we got ten gallons of oil, which sold at Brisbane at 4s. 6d. a gallon." When his remains were thrown

over the side, they were as usual very soon disposed of by his affectionate friends and relations, waiting near, and delighted to profit by the good fortune. The flesh is not bad eating when young.

The shark is always attended by a small blue pilot-fish, which swims about five yards in front of him, and evidently guides him and warns him of danger, his unwieldy size and length making it difficult for him to turn. The pilot-fish appears to do his kindly offices from pure friendship, with no filthy lucre of gain; but he probably benefits in some way by the leavings of his great ally, or the small fry which gather round a dead prey. There is another (strictly speaking) parasite which attends the shark—the sucker-fish, about sixteen inches long, which fastens itself on to him by a curious patch at the back of its head, not unlike the sole of an India-rubber shoe: this adheres with such force that a strong man can hardly drag the fish away when it has thus fastened itself to the deck. Sometimes twelve or fifteen of them may be seen hanging on to one shark. Probably they find it convenient to seek their food, thus traveling, as it were, on their own carriage, free of cost or trouble, and rushing through the water at a rate which their unassisted exertions would certainly never attain.

FIG. 2.



SHARKS' TEETH.

But, on the other hand, they must endure some very hard quarters of an hour, when their great friend gets into trouble, helplessly hanging on to his fortunes as they are.

The perils of the sea are certainly doubled in the regions where these dreadful jaws are to be found. And the certainty of such a death was one of the most touching parts of the simple heroism shown by the soldiers on board the *Birkenhead*. As is well known, she was a transport-vessel employed to take out detachments to various regiments in South Africa, with the wives and children. She struck on a pointed rock near Simon's Bay, and it was soon found impossible to save her. The men were drawn up on deck by their commanding officer, and not a man stirred from his place as the women and children were put into the few boats and sent off in safety to the land. Then, standing as firmly as if on parade, with the sharks swimming around, the whole body of men, with their officers, went down in the ill-fated ship, very few of them being able to reach the shore.

There are more gallant things done in quiet, unobserved moments, and obscure corners of the earth, even than before the enemy. It

was far more difficult thus in cold blood to face a dreadful death, with no excitement or sympathy from without, than to fight a whole array of cannon in a Balaklava charge.

A young engineer-officer, some years back, was stationed in New Zealand, in a very out-of-the-way district, far from the settled country. He was a gallant fellow, full of high aims and objects; besides which he rode well, shot well, could manage a boat, and swim admirably, and had attained a twofold influence over the natives by his fearless courage and his noble nature.

One stormy winter's afternoon, the sea running excessively high, and a tremendous surf over the bar, a ship was seen laboring into the roadstead of the small village near which he lived; she was hoisting signals of distress, and was believed to be an expected immigrant-vessel, and therefore with women and children on board.

The weather was so bad that there seemed no chance of her outliving the gale, and not a sailor on the shore would lend a hand to help, when Captain Symonds proposed to man a boat. Perhaps it may be said that they knew the perils to be encountered better than a landsman, however expert. Captain Symonds then called upon the Maories to join him, and they immediately followed him into a risk of life which the Englishmen refused to encounter, and for the sake of sufferers not of their own race or country.

The boat pushed off; the wind was on the shore, the surf running in violently, and a cross-sea made it more dangerous; the bay, too, was known to be full of sharks. Still, however, the little boat held on till within a few cables' lengths of the distressed vessel, which was watching them anxiously, when the tremendous heave of a wave struck her side and she was capsized. Captain Symonds was seen swimming undauntedly toward the shore, holding on by an oar, but he was swallowed up by the sharks before he had made any way. Two of the gallant black fellows escaped. The vessel perished in the gale.

It required a far higher kind of courage to face such a death, on that dark stormy winter's evening, in the attempt to rescue unknown passengers on board an unknown ship, than to storm the worst breach ever surmounted in war, surrounded by one's comrades in the heat of a battle raging in one's sight. The simple doing of God's work at the moment when it was required, with no interior bargaining as to the "worth while" of the sacrifice, in this obscure corner of the earth (as it then was), by this young fellow, with his aspirations, his love of life, his healthy longing after distinction, and the distinguished career open to him, made his death as gallant an act as can be found even in the long record of such deeds to be told of our English soldiers and sailors, the largest portion of which are scarcely heard of at the time, and are forgotten quickly afterward.

The sharks are certainly not heroic themselves, but they are the cause of a great deal of heroism in others.—*Good Things.*

HEALTH AND COMFORT IN HOUSE-BUILDING:<sup>1</sup>

BY DR. JOHN W. HAYWARD.

AS implied in the title, my subject is not house-building itself, as such, but only certain arrangements for health and comfort therein. House-building has at least two aspects—architectural and sanitary. The former belongs exclusively to your own profession, but the latter comes within the sphere of the medical profession also. It is the architect's province to provide dwellings for the people, and to see that they are made protective and safe; and it is part of the medical man's province to help to make them healthy and comfortable. In this respect the medical profession has lately been very forcibly reminded of its duty by Mr. George Atchison, who said: "No greater benefit could be conferred on mankind than the teaching them the necessity of ventilation, but that lesson is more likely to be learned if it come from the doctor than from the architect. . . . Until the faculty can convince the people that their life is shortened and serious diseases are brought on by want of ventilation, architects have no chance."

House-building being the point in which the duties of the architect and the physician meet, it becomes necessary that architects and medical men should occasionally discuss together the requirements involved in this art. Much public and much mutual benefit would, I am sure, result from such a practice. The object I have now in view is to invite your consideration of a few conditions of house-building that I deem of particular importance in a sanitary and medical point of view.

In building a dwelling-house, the conditions I deem of essential importance are the following:

1. That the house shall be so placed as to be as much as possible exposed to the fresh air and sunlight; *because* fresh air and sunlight are essential to the health, and growth, and life of the occupants. The *site*, therefore, should be rather elevated, if not absolutely, at all events in comparison with the surrounding objects.

2. That it shall be absolutely free from damp; *because* a damp house is a most potent, and active, and ever-present cause of disease, especially of rheumatism, neuralgia, colds, coughs, consumption, and such like. The *site*, therefore, if not naturally dry, must be rendered so by means of asphalt or cement, throughout the foundation, and the roof, and gutters, and drainage must be perfect. All the house-drains should terminate outside the house on an open grid or trap; that is, they should be cut off from the street drain, and they should be ventilated by having a pipe run up from every soil-pipe and every bend in the house.

<sup>1</sup> From a paper read at the Royal Institute of British Architects, Liverpool.

3. That it shall be so placed that the direct rays of the sun shall have free admission into the living apartments; *because* the sun's rays impart a healthy and invigorating quality to the air, and stimulate the vitality of human beings as they do those of plants, and without sunlight human beings, as well as plants, would sicken and die. The *aspect*, therefore, should be southeast.

4. That the lookout from the living apartments shall be cheerful, lively, and interesting; *because* much of the time of the family must be spent indoors, and a cheerful lookout is as necessary to render indoors attractive and even endurable in the daytime as society is in the evening. The *prospect*, therefore, should be as extensive and varied as possible.

5. The apartments should admit into themselves a great quantity of light; *because* light is essential to the health and vigor of the inmates. The *window openings* should, therefore, be large; but, as the greater the surface of glass, the colder the rooms in winter, and the hotter in summer,

6. The window-openings should be well splayed, as well outside as inside, so as to do with as little glass as possible.

7. The *windows* should be so arranged as to admit the direct rays of the sun at the times when the apartments are in use; *because* it is when the apartments are occupied that they require the cheering and invigorating influence of the sun's rays. For instance, the breakfast-room window should admit the early morning rays; the dining-room windows, one should admit the morning rays for breakfast-time, and the other the noon rays for dinner-time; and the drawing-room windows, one should admit the morning rays for callers, and another the evening rays for company; and the bedroom windows should, if possible, admit the early morning rays.

8. The *interior* of the apartments should provide wall-space for the arrangement of furniture; *because*, without wall-space no manner of furnishing a room can make it either handsome, elegant, or comfortable. The *windows*, therefore, should be few, and they and the door and fireplace should be so arranged as to provide as much wall-space as possible.

9. In the bedrooms, the window, door, and fireplace, should be so arranged that the bed can be fixed entirely out of the draught, and not have to be placed between the window and door, the window and fireplace, or the door and fireplace; *because* a cold draught playing on persons while sleeping is often dangerous to life, and always destructive of comfort.

10. The *doors* of the apartments, besides not admitting cold air when shut, ought not to admit cold air when open; *because* the draught thus produced not only destroys the comfort of the apartment, but produces lumbago, rheumatism, neuralgia, etc., in the occupants. The *doors* should, therefore, open out of a warmed lobby or corridor.



11. The *apartments* should provide a large cubic space for air; *because* plenty of air is essential to the health and comfort of the inmates. The apartments should therefore be as large and lofty as possible.

12. The apartments, besides providing a large cubic space for air, should also provide for the escape of the foul and admission of fresh air; *because*, however large an apartment is, the air is sure to become deteriorated and contaminated when the apartment is occupied by living beings. There should, therefore, be *two special openings* to each apartment, one for the escape of the foul air, and another for the admission of fresh air. There must be *two openings*, an outlet and an inlet. It is useless to make one without the other; it is useless to make an outlet unless there is also an inlet, for no air can go out if none comes in. This is a self-evident fact; still it is very frequently disregarded in attempting to ventilate apartments. There will, for instance, be a perforated or louvered pane in the window, a perforated brick or grating in the wall, an Arnott's ventilator in the chimney-breast, an opening above the gas, with a tube leading to a grating in the wall or into the chimney smoke-flue, or some other contrivance for the escape of the foul air, while there is no opening at all for the admission of fresh air; and the doors and windows are made to fit as tightly as possible, and even list put round them to prevent any possibility of air getting in by them, as though that could go out which never got in! In these cases, if the outlet act at all as an outlet, it must obtain its supply down the chimney—hence a smoking chimney; but generally, instead of acting as an outlet, it becomes an inlet to supply the current up the chimney, and always so when the fire is burning—hence the cold draught so generally complained of from the ordinary ventilators, and hence the reason that ordinary ventilators are so generally closed up in disappointment and disgust, and ventilation decried as a nuisance, failure, and farce.

13. These *openings* providing for the escape of foul air and the admission of fresh air should, both of them, be *special and permanent*, and altogether independent of every other arrangement of the house; such as opening the windows, doors, chimneys, etc.; *because* the escape of foul air and the admission of fresh air are most needed when, in consequence of the coldness of the external air, we close the doors and shut the windows. Special *ventilation* is most needed in winter, in cold, frosty weather, with an east wind blowing, and when we are very careful to shut the doors and windows, and adopt every other means we can to exclude the out-of-doors air, particularly of sitting at table for meals, or round the fire for evening entertainment.

14. The *outlet* should take the foul air from the upper part of the room; *because* the foul air, being more heated, is specifically lighter than the fresh air, and so rises to the upper part of the room. The outlet should, therefore, be in or near the ceiling.

15. The outlet should be effectually protected against any possibility of back-draught—indeed, it should have a considerable amount of suction; *because* any liability to back-draught is quite incompatible with an efficient outlet. The *outlet*, therefore, should not communicate directly with the out-of-doors air, but, by means of a tube or flue, should pass through some permanently heated contrivance. If the outlet go directly to the out-of-doors air—as, for instance, a tube from over the gas to a grating in the outer wall—there will certainly be back-draught; and so also will there be if the tube lead to an opening into the chimney-flue; at any rate, when the fire is not burning, and particularly if the room-door be also open, and most certainly if there be also a strong draught up the chimney of another room opening out of the same lobby, as, for instance, a dining-room or a kitchen. To prevent any possibility of back-draught the outlet should be provided with some means of constant suction, and, the more thoroughly to remove the foul air, the more suction the better, provided there is also an ample inlet for fresh air: if not ample, the suction would produce a smoking chimney and draughts from around the windows and doors, and perhaps draw in air from foundation and drains. The necessity for this suction is generally acknowledged, and it is sometimes attempted to be gained by carrying the tube before mentioned up a little way in the smoke-flue, and even by bending it down and round the fireplace. But a fatal objection to this plan is, that it is quite inoperative for the greater part of the year, and is of no use whatever unless the fire is burning; when the fire is not burning it may, indeed, become an inlet, and then an additional objection is, that a back-draught down the smoke-flue carries the soot into the room, to the spoiling of the ceiling, paper, and furniture. And, to be really effectual, the suction referred to must be *constant* and *permanent*, and operative both winter and summer, and day and night; and whether the apartment is occupied or not, and whether the fire is burning or not. The *outlet* must, therefore, pass through some contrivance for keeping it constantly and permanently heated.

16. The *inlet* should admit only warmed air; *because* the admission of cold air would produce dangerous draughts, and these specially directed toward the part of the room occupied by the inmates in cold weather, viz., the neighborhood of the fireplace. The *inlet* should, therefore, open out of a warm lobby or corridor.

17. The *outlet* should be sufficiently large to carry off all the foul air at the time when the apartment is being put to its maximum of use; *because* it is just at that time the outlet is most needed, its capacity for other times could be regulated by a valve. The outlet for a dining-room, for instance, should be calculated for a dinner or supper party, and that of a drawing-room for a ball, *conversazione*, or *soirée*, and should be sufficiently capacious to carry off, at the very least, fifteen cubic feet per minute for each occupant. The outlet should,

however, be considerably less than the inlet, or it will produce draughts.

18. The *inlet*, on the contrary, should be as capacious as possible ; *because* it has to provide not only for the outlet in the ceiling, but also for the chimney, and that when the fire is burning and requiring for its supply alone from 600 to 1,000 cubic feet per minute. Indeed, the *inlet* should be able to admit more air than can possibly find its way out by both these outlets, otherwise it will produce draughts. When the air can get out of an apartment more rapidly than it can come in, there are sure to be currents ; but when more air can come in than can get out—when the air has to go out under pressure, so to speak—there will be little or no current. And the *inlet* should be through the wall of the opposite side of the room to the fireplace ; *because* the fire will then draw the air into and across the room, and thus cause it to circulate throughout the whole of the apartment. If the fireplace be on the same side as the inlet, it will not only not assist to circulate the air throughout the apartment, but it will prevent it from so circulating by drawing it directly up the smoke-flue ; and it should, moreover, be split up into as many divisions as possible, so as to distribute the supply along the whole side of the room, and thus assist to prevent any perceptible current ; and this will be further helped by having the openings through the cornice instead of through the skirting, because then the fresh air will be the warmest that is in the corridor, and it will also have to descend through the warmer air of the room before it can come in contact with the persons therein. When through the skirting, it is the coldest air of the corridor ; it comes through the coldest air of the room, and it comes first to the part of the body where it can least be borne, viz., the feet.

In this country (England) it is necessary to provide specially for ventilation. In consequence of the nature of our climate, the doors or windows can very seldom be left open, even in the day, and never in the night, without risk. Indeed, no direct admission of the external air into the apartments of the house can be endured during at least eight or nine months of the year—in fact, the great prevalence of cold, searching, and shriveling east wind renders such an admission absolutely dangerous ; so that no kind of arrangement of openings directly to the out-of-doors air, such as drawing down the window-sash, perforated bricks or gratings in the wall, perforated or louvered square in the window, the wire-gauze at the top of the window-sash, patent ventilators, or any other contrivance that communicates directly with the out-of-doors air, can possibly answer for ventilation in a country like ours. In this country, where eight or nine out of the twelve months in the year are cold, windy, and winterly, houses should be built with reference to winter, and not with reference to summer ; and they should be planned and built with the object of keeping out the cold air and not with the object of letting it in ; ventilation should be pro-

vided for specially ; and in making this provision it should be borne in mind that we are living at the bottom of an ocean of air, and that the same manipulation is required as though we were living at the bottom of an ocean of water, and were endeavoring to make it come in at the bottom of the house and go out at the top in a continuous stream.

From the foregoing remarks it will be seen that I maintain that *ventilation* is the great and main necessity of house-building ; and that, whatever else may be left undone, this should be attended to ; and, whatever else may be left imperfect, this should be made perfect and complete ; and that it should include the whole house ; and should be self-acting and inexpensive. It should, I repeat, be perfect and complete, include the whole house, and be self-acting and inexpensive.

Ventilation is *the* point for discussion between the architectural and medical professions, for it is here in particular that their duties meet and combine ; the education, knowledge, and experience of both professions are wanted here. However much the medical man may be impressed with the absolute necessity of rooms and houses being ventilated, he cannot himself provide it—this must be done by the architect ; and, on the other hand, the architect cannot be expected to provide flues and tubes, which involve extra expense, except under the certainty that they are absolutely necessary and required arrangements involved in the plan of every house. But there is a third party interested in this subject, namely, the public. The public are, after all, the “yea” and “nay” in this matter ; it is, indeed, for them that these arrangements are to be made, and they are the paymasters. Whatever extra cost is involved, it is the public that will have to pay it ; and it is of little use for a doctor to prove the necessity, or for an architect to design the arrangements, unless the public be persuaded to adopt them, and pay the cost involved. That the public can be thus persuaded I have no doubt, but that this will take some time I am equally ready to admit. It will take some time thoroughly to educate the public into the absolute necessity for special provisions for ventilation, because they have hitherto been left under the impression that special arrangements for ventilation are unnecessary and superfluous, or that they are impracticable, or at least incompatible with warmth and comfort ; and I am sorry to have to add that they have been encouraged in this impression by many architects and engineers, and that medical men have not protested with sufficient force and intelligence. Medical men have gone on from generation to generation silently mourning the resulting evils of the want of efficient and practicable means of ventilation, and architects have continued to design houses with very little regard to these absolutely necessary provisions ; while the public have submitted, and, if they have not thought it was all right, have at least thought that the evil was quite beyond

their remedying, because every amateur (if not every professional) attempt hitherto made had only ended in failure, disappointment, and loss of money.—*The Builder*.

---

## HYPNOTISM IN ANIMALS.

BY PROF. JOSEPH CZERMAK.

TRANSLATED FROM THE GERMAN, BY CLARA N. HAMMOND.

### *Lecture Second.*

YESTERDAY we proceeded far enough in our study of Kircher's experiment, relative to the imagination of the hen, to establish the fact of the usefulness of the string and chalk-line as necessary parts of the procedure. Indeed, the stretching out of the neck and the depression of the head are the only circumstances left which make any decided impression on us. And, so far as we can see, the gentle extension of certain parts of the brain and spinal cord which is produced, appears to be the cause of the remarkable effect which ensues. Nevertheless, we must not be too hasty in forming our conclusions; we must not, as the unlearned do, remain standing at an "event viewed unequally."<sup>1</sup> For, however apparently useless the string and chalk-line may be, it is yet possible that they are not entirely without influence; and, on the other hand, the extension of the neck and depression of the head are by no means established as necessary circumstances to the perfection of the result. So, to-day, as already announced, we will resume and complete our investigations, and, at the close, I will endeavor to show what relation the whole subject has to natural science, to "spiritualism," etc.

And I must request you to dismiss from your minds the hypothesis that the extension of the neck and depression of the head have any especial significance, for I have been entirely unable to produce in pigeons the hypnotic effect which so readily ensues in hens, although I proceeded in as nearly as possible a similar manner. On the contrary, repeated experiments have shown that the unavoidable pressure exerted upon the animal, as it is held, is of primary importance, and that the apparently insignificant chalk-line is undoubtedly of some moment. It is frequently the case that a hen, which, for a minute, has been in a motionless state, caused by simply extending the neck and depressing the head, awakes and flies away, but, on being caught again immediately, can be placed once more in that condition of lethargy, if we place the animal in a squatting position, and overcome with

<sup>1</sup> By this phrase Prof. Czermak (pronounced Tshermak) means those cases of observation in which the eyes and ears perform correctly, but the perception is at fault. The reporter tells the truth, but what he reports never actually took place. An *event viewed unequally* is one that has not been thoroughly tested.

gentle force the resistance of the muscles, by firmly placing the hand upon its back. During the slow and measured suppression one often perceives an extremely remarkable position of the head and neck, which are left entirely free. The head remains as if held by an invisible hand in its proper place, while the neck is stretched out of proportion, and the body by degrees is pushed downward.

If the animal is left thus entirely free, it remains for a minute or so in this peculiar condition, with wide-open, staring eyes. (The lecturer here caused a hen to be brought, which he placed in this remarkable position by simply stretching out the neck and pressing down the head; the bird, having awakened, gave signs of returning to the same state when it was placed in a squatting position, without moving head or neck.) Here the actual circumstance is only the consequence of the emotion which the nerves of the skin excite, and the gentle force which overcomes the animal's resistance. Certainly, the creature a short time before had been in this condition of immobility, and might have retained some special inclination to fall back into the same, although the awakening, flight, and recapture, together with the refreshment given to the nervous system, are intermediate circumstances. Similar experiments, where the influence and effect of the pressure which is placed on the animal's muscles are manifested upon the cutaneous nerves, are best made upon small birds.

To bird-fanciers, it has been a long-known fact that one can rob gold-finches, canary-birds, etc., of the powers of their nervous systems, so that they remain motionless for a short time, by simply holding them firmly for a moment, and then letting them go.

These experiments, which I will endeavor to perform before you, are particularly striking, on account of the vivacity of the timid animals. Yet I must remind you of a possible failure, due to the unusual circumstances of noise and numbers which may have a disturbing influence on these excitable little creatures.

Here in my hand is a timid bird, just brought from market. If I place it on its back, and hold its head with my left hand, keeping it still for a few seconds, it will lie perfectly motionless after I have removed my hands, as if charmed, breathing heavily, and without making any attempt to change its position or to fly away. (Two of the birds were treated in this manner, without effect, but the third, a siskin, fell into a sleeping condition, and remained completely immovable on its back, until pushed with a glass tube, when it awoke and flew actively around the room.)

Also, in a sitting position, with the head held a little to the back, the birds fall into this sleeping condition, in spite of their open eyes; indeed, I have often noticed that the birds under these circumstances close their eyes for a few minutes, and even a quarter of an hour, and are more or less fast asleep.

I cannot omit to notice, with many thanks, that our assiduous nat-



uralist, Herr Geupel-White, has most kindly placed at our disposal the rich material his zoological garden affords, to assist us in these experiments.

My former experiment with the swan was also performed in Herr Geupel-White's garden. In the experiments with the small birds, the condition of immobility, which can change to actual sleep, is only caused by the effect of the impression made in the animals, through touching the skin and overpowering the resisting muscles. You will see this in the continuation of our experiment. That, however, the exciting of certain cutaneous nerves alone changes the normal functional capacities, and calls forth a singular state of stupidity, is proved by the following highly-interesting experiment with a frog, which Dr. Lewisohn, in Berlin, has suggested, and most thoroughly investigated:

If one places a frog on its back, it does not remain in this unnatural position for an instant, but, on the contrary, turns itself over and escapes. This you may see yourselves, when I endeavor to place this frog on its back. But please notice the astonishing result if we tie its two fore-legs with a string. (The lecturer tied threads around each of the frog's fore-legs, drew the threads tightly, and laid the animal, as before, on its back.) You see that the frog, breathing heavily but otherwise quite motionless, now lies on its back, and does not make the slightest attempt to escape, even when I endeavor to move it. It is as though its small amount of reasoning power had been charmed away, or else that it slept with open eyes; an analogous condition to that which we saw in the crabs, hens, and little birds. The only difference is, that the actual connection of the phenomena is much clearer. Now, I press upon the cutaneous nerves of the frog, while I loosen and remove the threads on the fore-legs. Still the animal remains motionless upon its back, in consequence of some remaining after-effect; at last, however, it returns to itself, turns over, and quickly escapes.

That it is here a matter of restraint upon the nervous centres, in consequence of the pressure on the sensitive cutaneous nerves, Lewisohn has already proved. In this experiment, the impulse of motion on the nervous fibres, which proceeds from the so-called motory centre of the brain and spinal cord, remains quite capable of action on one side, while, as regards the other side, the remarkable condition of stupidity will no longer happen, if we have divided the cutaneous nerves before tightening the threads.

Sometimes it is possible to make the frog lie motionless on its back without the threads; but this proves nothing against the soundness of Dr. Lewisohn's results.

But let us return to our old *experimentum mirabile*<sup>1</sup> of the hen. According to the analogy of the last experiments with the frog, the tying together of the hen's feet, although not necessary, may contribute something to the effect in Kircher's experiment, not only by

<sup>1</sup> Admirable experiment.

keeping the animal firm and quiet, but also by pressing upon the cutaneous nerves. In order to understand the whole subject, we must go further and adduce other facts which bear upon it.

The most interesting part of our investigation still remains, which, as I remarked beforehand, will lead us to the doubtful regions of mesmerism and somnambulism. And the question arises again: Has the apparently unnecessary chalk-line in Kircher's experiment any significance; and, if so, what?

I have already mentioned that I did not succeed in placing pigeons in this motionless state by holding them firmly in my hand, and pressing their heads and necks gently upon the table, as I did the hens.

I therefore endeavored to treat the pigeons as I did the little birds, that is, I held them with a thumb placed on each side of the head, which I bent over a little, while the other hand held the body gently pressed down upon the table.

Even this treatment, which has such an effect on little birds, did not seem to succeed at first with the pigeons. Almost always they flew away as soon as I liberated them and entirely removed my hands. I remarked, however, that the short time, during which the pigeons remained quietly in my fingers, increased visibly, and lengthened several minutes, when I removed the finger of the hand which held the head, only removing the hand very little, or else not at all. The hand holding the body could have been removed much sooner without doing any harm.

While I zealously pursued this trace of new events, I found, to my astonishment, that it led me to the observation of the pigeon's attention, and the fixing of its look upon my finger placed before its eyes. It is this movement which, until now, has not been taken into our consideration, and is the critical period which is of such great importance as a link between the phenomena we have noticed and others to which we are gradually approaching. In order to determine the matter still more clearly, I tried the experiment on a pigeon which I had clasped firmly by the body in my left hand, but whose neck and head were perfectly free, and held one finger of my right hand firmly before the top of its beak—and what did I see? The first pigeon with which I made this attempt remained rigid and motionless, as if bound, for several minutes, before the outstretched forefinger of my right hand!

Yes, I could take my left hand, with which I had held the bird, and again touch the pigeon without waking it up; the animal remained in the same position while I held my outstretched finger still pointing toward the beak. (The lecturer demonstrated this experiment in the most successful manner with a pigeon which was brought to him.)

I have repeated this striking experiment on a number of pigeons, yet I do not know whether suitable animals are frequently found, for, of course, it is to be understood that the experiment cannot always

entirely succeed, as it concerns essentially the concentration of the pigeon's attention, and the fixing of its look. Individual, inward relations, as well as outward conditions, must necessarily exercise some disturbing influence, whether the animal will give itself up to the requisite exertions of certain parts of its brain with more or less inclination, or otherwise. You then understand why apparently little circumstances may be responsible for the result of an experiment in which this critical moment plays a part.

We often see, for example, how a pigeon endeavors to escape from confinement by a quick turning of its head from side to side. In following these singular and characteristic movements of the head and neck, with the finger held before the bird, one either gains his point, or else makes the pigeon so perplexed and excited that it at last becomes quiet, so that, if it is held firmly by the body and head, it can be forced gently down upon the table. It is as Schopenhauer says of sleeping, "The brain must bite." I will also mention here, by-the-way, that a tame parrot, which I have in my house, can be placed in this sleeping condition by simply holding the finger steadily before the top of its beak.

But let me hasten, gentlemen, to say to you that, in the remarkable and singular influence which the holding of the finger exercises on pigeons, the influence of the mythical agents may not be removed; agents which may come from the organization of the experimenter, and, perhaps, spring from the outstretched finger. Nevertheless, a glass tube, a cork, a small wax-candle, or any other equally lifeless substance, placed directly on the top of the pigeon's bill, has the same magical effect as when the human finger is used. We must only be careful that the animal be placed so that its attention is fixed for some time on the object. I have seen pigeons sit motionless for some minutes, with open eyes, after I had placed a lucifer-match, or a wax-light, on the top of their bills.

Often, with hens, these experiments succeed in the most astonishing manner. I have repeatedly seized hens with both hands by the body so that their heads and necks were quite free, and forced them gently against a pedestal on which a glass tube was placed, so that it just touched the top of the bill. The animal, when left perfectly free, remained gazing fixedly at the glass tube for more than a minute. The same thing happened when a cork stopper was used, instead of the glass tube.

Finally, I will mention that with the hens I often hung a piece of twine, or a small piece of wood, directly over their crests, so that the end fell before the eyes. I mention this experiment especially, because, when performed, the hens not only remained perfectly motionless, but closed their eyes, and slept with their heads sinking until they came in contact with the table. Before falling asleep, the hens' heads can be either pressed down or raised up, and they will remain in

this position as if they were pieces of wax. That is, however, a symptom of a cataleptic condition, such as is seen in human beings under pathological conditions of the nervous system.

After I had discovered the events which I have just communicated to you concerning the hens and pigeons, two things were clear to me : 1. That the drawing of the chalk-line in Kircher's experiment was of some significance. The hand which draws the line, and the line itself, are transferred to an object in which the animal's look and attention are placed, through which a marvelous condition of certain parts of its nervous system is called forth, accompanied by cataleptic phenomena, and which can change to sleep.

2. That it produces soporific phenomena in animals, as has long been conjectured, but, until now, never investigated or proved ; a peculiar and mysterious state, resembling sleep, accompanied by cataleptic appearances and a change in the nervous system. This can be produced in many men by a simple fixing of the look on some small object, and through a concentration of the will.

It is well known that, in the year 1851, Mr. Braid, a Scotch surgeon, established in Manchester, who was present at the mesmeric exhibitions of Lafontaine, was first struck with the idea that these phenomena, proclaimed as the effect of a magnetic fluid, were only a natural consequence of the fixed look and entire abstraction of the attention, which present themselves under the monotonous manipulation of the magnetizer. Mr. Braid proved in his experiments the entire dispensableness of a so-called magnetizer, and his supposed secret agents, or fluids, produced through certain manipulations ; he taught the subjects of the experiments to place themselves in this sleeping condition, by simply making them gaze fixedly at some object for a long time with strict attention and unmoved gaze. It is therefore clear that this condition of the nerves, caused by the steady look and attraction of attention, in one part of the brain, brings the other parts into action with it and changes the functions, to whose normal activity the phenomena of the will are united. This is the actual, natural, physiological connection of this mysterious appearance. It only remains to us now to ascertain which portions of the brain first and secondly become altered, and in what these changes consist.

According to Braid, for example, on one occasion, in the presence of 800 persons, ten out of fourteen full-grown men were placed in a sleeping condition in this way. All began the experiment at the same time ; the former with their eyes fixed upon a projecting cork, placed securely on their foreheads ; the others, at their own will, gazed steadily at certain points in the direction of the audience. In the course of ten minutes the eyelids of these ten persons had involuntarily closed. With some, consciousness remained ; others were in catalepsy, and entirely insensible to being stuck with needles, and others, on awakening, knew absolutely nothing of what had taken place during their

sleep. Even more; three persons of the audience fell asleep without Braid's knowledge, after following the given direction of fixing their eyes steadily on some point.

Braid's experiments, which are designated as the beginning of a scientific investigation of extremely complicated nervous phenomena, did not find at first the esteem and homage due to them, and gradually sank into oblivion. This is explained by the fact that they were associated with mesmerism; and Lafontaine, whose "magnetic" exhibitions were the first cause of Braid's investigations, protested, not without some animosity, that "hypnotism," or "Braidism," was identical with *his* "mesmerism." Braid himself, in the course of his experiments, seems to have lost his former scientific force as an investigator. Then, in 1848, Mr. Grimes, the American, with his "Electro-Biology," appeared, and took up the intellectual epidemic of mediums and spiritual apparitions, which we witnessed in astonishment, and saw the whole world more or less impressed by it. It was, naturally, then, not at all surprising that hypnotism, or Braidism, remained almost unknown to science. Only once it attracted scientific attention and interest, and then only for a short time. This was in 1859, in December, after Velpeau and Broca, two well-known French surgeons of *La Société de Chirurgie*, in Paris, caused the most immense sensation by placing twenty-four women in a sleeping condition by Braid's method, and then performing surgical operations without causing them the slightest pain.

Then much was said in the journals about "hypnotism" in hens, the description of which had already been found in one of Father Kircher's works. Although characteristic enough for those days, yet, to my knowledge, no one has been much impressed by the investigation of Kircher's *experimentum mirabile*, for it treats of a real state of hypnotism; and, with animals, every one feels safe from all thoughts of deception, but yet can bring into application all physiological means of investigation, in order to penetrate the mysteries of the phenomena. *This proof of the actual appearance of hypnotism in animals is the scientific result of my above-communicated observations and experiments, which I intend to continue upon mammals, on which I have not yet experimented.*

These, however, have still another interest for us. They have strikingly demonstrated how difficult it is to obtain actual facts from "events viewed unequally." They have still further shown us what insight, what strength of demonstration, and sharpness of criticism, scientific investigations demand; and, finally, they have made known to every discerning person how little weight should be attached to the reports of the most honorable and upright people, when these people are not entirely penetrated with the idea of the exact nature of the investigation.

This never-to-be-neglected foresight, in the estimation of reports

and testimonies relative to such actual phenomena as appear to exceed the usual events of Nature, is especially justified when, in the sleeping condition of the animal, every trace of visible deception is removed; how much more so are doubt, reserve, and refusal, an irrefragable law and duty, when it treats of phenomena which, on one hand, are a scorn to science, and, on the other, not only give rise to suspicion, but are an actual visible deception! This last double character marks thousands of phenomena which eyes and ears have considered real in mesmerism, clairvoyance, spiritualism, etc.

In the mean while, strict natural science never decides *a priori*, and the indicated character would never prevent science from drawing phenomena of such a character into the range of its investigation and trial. And yet, the science of our day is placed, in every respect, opposite to spiritualism and its relations. Are not the passionate complaints and reproaches to which the representatives of science, and even science itself, are exposed, from the countless fanatics and believers of this mysterious faith, quite unjustifiable?

By no means! It will be easy, after all you have seen and heard here, to justify the bearing of science. I considered myself unable to withdraw from this ungrateful task, because it is a duty of my especial profession to prepare a true explanation, and because my previous scientific research has led me to the region where superstition, prejudice, credulity, and even worse, absolutely rule. I called the task "ungrateful," because one finds powers in opposition against which, as Schiller says, "the gods themselves struggle in vain."

They who are occupied with the questionable regions, which are made attractive and ensnaring through wonderful and mysterious things, are divided into two classes. The first is formed of persons who care nothing about the confirmation and investigation of remarkable events, but, on the contrary, occupy themselves with those events through sordid but harmless motives. To this class belong the frivolous, and those professionless people who are influenced by vanity, and endeavor to kill time with apparently great industry. Of this class it is not necessary to speak further.

The other class is composed of upright people, who mean honestly; and these have a right to be looked after, and set properly on their course, even if teaching and advice find deaf ears.

In this class are two distinct groups: 1. Good people, but bad investigators; that is, the scientific know-nothings, who have never occupied themselves particularly with natural researches, and their results and methods; 2. Scientific people by reputation, who have performed, for their own special departments, real services for science.

Of those who belong to the first group of this class, and who, without profession or special education, undertake to explore such complicated and puzzling events, we can simply say: If these true-hearted people only had an idea of the requirements and difficulties



of an exact natural investigation, a slight comprehension of the strength of the proof which science must absolutely command, if it treats of the confirmation of events, and the connection of the simplest circumstances, they would entirely cease from their senseless and fruitless endeavors, and seek to acquaint themselves with the valuable acquisitions of to-day's teachings, without which man—comparable to a ship without a compass or rudder—tossed about on the sea of error and deception—can be perplexed to imbecility! The excellent advice to keep at a distance all mysterious and supernatural manifestations, in spite of their charms and attractions, has already been communicated to you. An instructive maxim says, "There is a virtuous spirit of relinquishment in intellectual as well as in moral power." And here, in order not to be led into temptation, men must carry this relinquishment to the extreme of intellectual "teetotalism." It is more difficult to deal with the second group of this class. It is clear that if the few natural investigators who compose this group were not entirely divested of the spirit of strict research which they may once have possessed, they would have found ways and means to confirm, in a scientific manner, the "events viewed unequally" which they are not ashamed to testify to as though they were actual circumstances, so as to win the confidence and esteem of all natural investigators. As they have by no means succeeded in this, the weight of their testimony sinks, in spite of its truth, to the level of that of the unlearned persons mentioned in the first group of this class.

In reference to the perception and knowledge of natural events one cannot vote, *per majora*, as in human laws. The votes here must be weighed. However, to give no opportunity for misconstruction, I will say, beforehand, that the natural investigators of whom I speak have not lost all their weight and respectability in science because they vouched for the reality of unheard-of and absolutely incredible events, but because of the foundation on which they placed this testimony.

They refer us triumphantly to the "scientific" investigation of a Hare, a Crookes, a Butterow, and other well-known "natural investigators!" However, he who examines this startling literature, will only become more confirmed in his ideas. The way alone in which these "investigators" perform their experiments, and the manner in which they make their reports, prove very clearly that they are really no investigators at all. To give one striking example, Crookes announces earnestly to the scientific society of London, of which he is a member, that he has discovered a new feature in Nature, which he calls "psychic force." Through the influence of this force, according to Crookes, the weight of a body can be increased or diminished several pounds, without visible interference!

And how do you think Crookes has investigated and estab-

lished this marvelous circumstance? You will hardly deem it possible, when I tell you he did it simply by noticing, in the presence of certain people, that a spring-balance, of the same kind as one uses to weigh letters, gave movements the causes of which were not apparent.

I will here show you a small drawing, so that you may understand

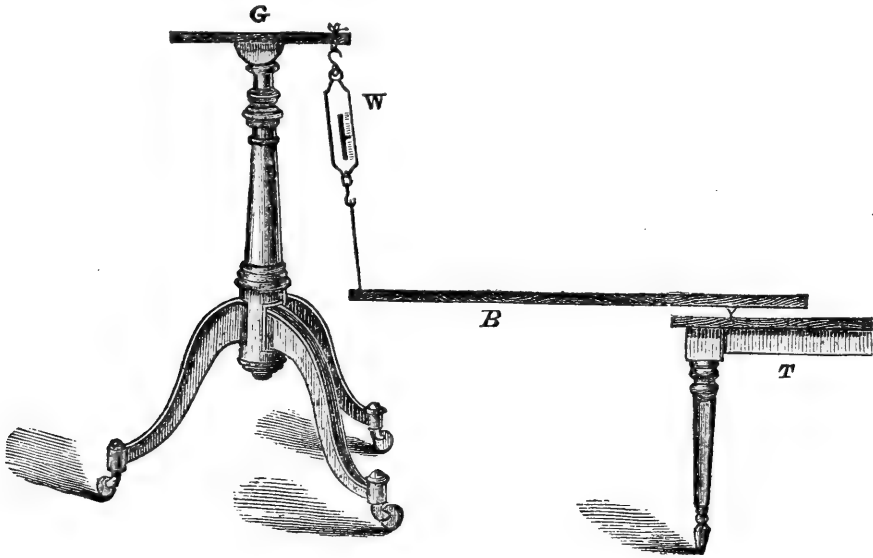

it better, which illustrates the principle of an apparatus used by Crookes. *B* is the strong mahogany board, several feet long, one end of which rests on the table, *T*, by means of a sharp point placed in the under side, while the other end is fastened to the balance, *W*, which hangs suspended from a rest, *G*. The index of the balance shows how great the weight is which it has to bear. Every movement backward or forward, any shaking or pushing which is communicated to the board, must be made perceptible through a rising or falling of the index. And now, Crookes assures us that he has perceived such motions of the index, in the presence of others, when Mr. Home, the principal medium, did not move the apparatus at all, but was held firmly by the hands and feet, some distance from it! And that is all! Crookes ventures his monstrous assertion on the ground that the balance made motions which appeared to have no cause whatever! Whoever is satisfied with the general assertions of Crookes, in this respect, manifests such incapability of judgment concerning science, that he has simply no right to speak about such things.

That a balance makes motions is a circumstance very easy to establish. We can accept it, as an actual event in Crookes's evidence, that the balance has really made some motions in the presence of the so-called mediums; but when Crookes represents as an actual event that it was the "psychic force" of the medium which caused this motion, and altered considerably the weight of the body, it is, in spite of all persuasion, no real circumstance, but a well-meant assertion of an "event viewed unequally;" a statement which does not deserve the

slightest belief nor the smallest amount of consideration. This assertion does not deserve the latter, simply because it concerns an "event viewed unequally" (for there are many events in this category which deserve the highest esteem), but because the admissible part of Crookes's statement is in itself worthy of no notice, and because not the slightest proof is furnished that the motions only proceeded from the so-called medium, and that they could partake of no heretofore well-known natural cause!

Had such a proof been undertaken in an exact manner, Crookes's assertions would probably have deserved some notice, which would have led to a repetition of his experiment, in order to test more thoroughly his "event viewed unequally;" if this proof had been strictly enforced, Crookes would have discovered one of the most remarkable known events, and his assertions would have at once commanded the utmost respect and consideration from all natural investigators; as, perhaps, with Volta, when he built his pile, which presented no less incredible appearances! But, as the events stand, Crookes's statements, as with hundreds and thousands of "events viewed unequally," concerning moving tables, flying guitars, self-playing pianos, etc., have been regarded with exactly the same claim to science as the best and most astonishing sleight-of-hand performances, which no one can admit to be real natural investigations, although in a psychological respect the real cause of the deception may be very interesting.

Little as it may affect a reasonable man, not to be able to investigate some pretty and striking conjuring trick, so also no one ought to disquiet himself on account of events which hundreds of people have testified to, even when the slightest proof is unproduced, so that every thought relating to the possibility of such an interesting natural phenomenon is removed.

Only through the idea that the phenomena are not visible do these latter present a most remarkable significance in the eyes of the unlearned. But, in this significance, they make no difference between it and conjuring, which is often much more interesting and not less inexplicable. But do they make a distinction in any other respect? As to that we will ask, at first, a little information from the "spiritualists," "natural investigators," and "*savants*," such as Varley, Wallace, Crookes, Butterow, and others, before we allow them the right to make the slightest reproof concerning science, and the dependence of these things upon it.

These gentlemen have not the shadow of a right to complain of any thing save their own incapability, nor have they the right to make a reproach to any one except themselves, that they did not succeed in establishing their "spiritual manifestations."

I will expressly emphasize the fact that I did not say that one must regard all phenomena, which occur daily, and which are of the greatest significance and importance, as mere conjuring-tricks, al-

though numbers of them could be proved to be such. Remember the Davenport scandal! For me, the first "manifestations" are entitled to as little consideration as the latter, and I selected the best authenticated of them when I communicated Crookes's experiments as a characteristic example of "spiritual" literature to the well-known English *savant*, the deserving scholar, our great chemist Hoffman, of Berlin, formerly of London. And has any one of the gentlemen who are "investigators" in this department said any thing to the credit of the deceased American chemist and "spiritualist," Dr. Hare? Does not one find in the literature which they have the assurance to refer us to, accompanied by brainless chattering and fanciful effusions, nothing, nothing at all, but childish or idiotic arrangements, supposed to represent a psychological apparatus, and more or less creditable reports as to the reality of "events viewed unequally?"

In the mean while, you may properly ask if these events, which have been witnessed by hundreds of worthy people, are needful of scientific examination and proof, and whether they are worth it? Oh, yes; but not all, and not in a very high degree. Science and its followers have the right to consult their own time and opportunity. They have something more to do than to occupy themselves in answering every question put to them. You all know the old saying relating to the fool and the seven wise men. That which is worthy of no earnest investigation, and which, nevertheless, can awaken esteem and confidence, in spite of all singularity, should raise no claim to consideration on the part of science. In this case, however, the moving tables, flying guitars, mysterious rappings, of course take no part.

The clamors of hundreds and thousands of eye and ear witnesses who triumphantly hint at "scientific investigations," but who are incapable of giving any proof of the experiments, do not change the matter in the least. Whether one or another investigator may consider these things, is entirely dependent on his personal opinion, and on casual circumstances. Whoever has no opinion on the matter, and holds aloof from it, cannot meet with the slightest reproach. My highly-esteemed friend Prof. Sharpey, who formerly was secretary for many years of the Royal Society of London, was perfectly right when he refused Mr. Crookes's invitation to be present at his experiments with Mr. Home; indeed, he acted with great wisdom, for spiritualists and fanatics are very much inclined to trumpet forth men of science as important witnesses on such occasions. The letter of the celebrated astronomer Huggins, written on the 9th of June, 1871, to Mr. Crookes, is nothing but a polite though decided denial of his opinion relative to different phenomena which had taken place in Crookes's house in Huggins's presence. And yet, this letter is quoted triumphantly, and Huggins, probably much against his will, is considered, from all sides, as one of the "scientific authorities" who

had delivered their testimony as to the reality of spiritual writings, supernatural manifestations, etc. Judge for yourselves! For the preservation of Huggins's honor, and as a striking example of these gentlemen's proceedings, I feel necessitated to communicate this doubtful letter to you:

MR. CROOKES:

UPPER SULSE HILL, *June 9, 1871.*

DEAR SIR: The proof-sheets which you sent me seem to contain a correct representation of what took place in your house in my presence. My position at the table did not allow me to witness the removal of Mr. Home's hand from the piano; but this is considered by you, as well as the person sitting on the other side of Mr. Home, to have taken place. The experiments show me the importance of further investigation. I, however, wish it distinctly understood, that I express no decided opinion in regard to the phenomena.

Your obedient servant,

WILLIAM HUGGINS.

Yet, as we have said, whether one or another scientific investigator examines these things, his personal opinion is entirely dependent on the circumstances. But, in regard to strict science, they simply do not exist at all. Science neither recognizes nor denies them; it simply ignores, and it has a perfect right to do this, because time and work are too precious to be wasted on phenomena which can offer no higher interest than that their causes are not apparent—exactly in the same way as with conjuring. In these days, no one is accused of possessing supernatural power, otherwise we might again begin to burn people for heresy and witchcraft. Heretofore, nothing has compelled us to suppose spiritual manifestations and dubious phenomena to be supernatural, and therefore the whole thing is probably not worth any consideration whatever, except perhaps in a psychological point of view.

The absolute opposition of science to spiritualism, etc., is entirely justifiable, as you, gentlemen, must admit, little as you may be satisfied with our views, or much as you have been deceived in your expectations. I can only say that, possibly in consequence of the long reserve of science, much, perhaps, to the harm of mankind, remained, and still remains, undiscovered; for one, with the modesty to which a natural investigator, more than any other else, is forced, can say with Hamlet: "There are more things in Heaven and earth, Horatio, than are dreamt of in your philosophy!" In the mean while this must be borne with. The right time will come for every discovery and every step of progress.

## THE SURVIVAL OF INSTINCTS.

BY ELIAS LEWIS, JR.

**A**NIMAL life has its episodes, and apparently abnormal habits. A gentleman, residing near this city (Brooklyn), had recently a turkey tethered with a cord in a field during the early life of her brood. He had also several other turkeys with which this one had a long time associated, apparently on the most friendly terms, and which, during her temporary confinement, strolled and fed quietly around her. But it happened one day that she became entangled with the cord, so that her feet were drawn together, and, being unable to walk, lay struggling on the ground. While thus helpless her associates attacked her, evidently for the purpose of killing her outright. They made no onset as when fighting, but deliberately and in the coolest manner possible commenced their butchery by picking the head of the unfortunate bird.

So intent were they that they scarcely heeded the approach of our friend, who, from a distance, saw what was going on. Before he reached the spot, the assailants had destroyed one eye and laid bare the skull, inflicting injuries so great upon the creature that she soon died. A similar act was repeated shortly afterward in the same flock, and the phenomenon—certainly a curious one—is, we believe, not unusual.

Observation and inquiry have shown that a like disposition appears not among turkeys only, but in several species of animals, exciting them, when aroused, to attack and worry those of their kind if weak, sick, or disabled. It has been noticed with cattle, swine, dogs, and, as has been suggested by observers, may occur with all domesticated or partly domesticated species in which it had existed in their wild state. We are informed by drovers, of whom we have made careful inquiry, that when herds of cattle are hurriedly driven, and especially when they become excited or alarmed, one having fallen, or showing signs of weakness, is sometimes set upon and gored by its associates.

Two gentlemen, who have been drovers forty years, and during many years were themselves collectors and drivers of herds, assure us that they have often witnessed such attacks, and have interfered to prevent injury. They also state that the habit appears to be more frequent with animals which have run at large without much care or restraint, than with those well domesticated.

Such occurrences, however, are well known among domesticated cattle. A gentleman residing on Long Island had, a few years since, a herd of cattle, one of which was taken suddenly sick, but was turned, as usual, into the field with the others. In a short time he noticed great disturbance among them, and, on hurrying to the spot, found



the sick one on the ground bellowing, and being gored by her associates. An acute observer, also residing on Long Island, near this city, Mr. J. D. Hicks, writes as follows: "In answer to thy inquiries, J. H. and S. R. inform me that the fact has been noticed in their own experience that the well ones of a herd do sometimes seek to gore and destroy a sick or maimed one. A cry of distress, instead of exciting sympathy, seems to invite attack, and the first movement by one is a signal for attack by others. Thee may rest perfectly assured of this. I have myself more than once witnessed it."

The gentlemen whose initials are given are large owners of cattle, and have for nearly half a century been familiar with their habits, and with the habits of those brought in droves from distant parts of the country. Of the habits of entirely wild cattle we know but little. The wild herds of the pampas have descended from tame stock, and it is not easy to show by instances the habits of the original wild stock in this particular. A breed of cattle formerly common in Southern Scotland, noted for their untamed and savage disposition, is spoken of by Cuvier, under the name of white urus, and he says: "When one of this breed happens to be wounded, or is enfeebled by age or sickness, the others set upon it and gore it to death."

With swine a similar habit has been observed. We are informed that it is sometimes necessary to separate disabled ones, for safety, from the general herd. The drovers already referred to state that, in the driving and transportation of swine, those which become sick and faint are often objects of attack. Drooping of the ears, and other evidences of exhaustion, seem to excite the propensity, and may occur while being driven, or in pens in course of transportation. In cars, where they are probably much excited, weak and fallen ones are often torn to pieces, and sometimes devoured.

On one occasion, after a sick pig was thus disposed of, a dead dog was thrown among the excited animals, but no notice was taken of it. We will mention, in this connection, that we have not learned of any instance of an animal, strong and vigorous, being thus attacked, nor where a sick or feeble one was defended by its associates when such an attack was made; and it is certain that with hogs, as with cattle, the more untamed they are, the more violent and savage is their disposition, and the more frequent the peculiar habit we have under consideration.

Audubon observes that, with the wild-turkey, the old males, on their marches, frequently destroy, by picking the head, those which are immature, but it does not appear that full-grown and vigorous birds are attacked. The old, sick, and disabled, are continually left to their fate by moving herds of the American bison, and are fed upon by wolves. That they are expelled by violence is probable, but, so far as we know, there is no positive proof of the fact. It is known that wolves, if wounded, are attacked and killed by their comrades;

and the arctic fox, if disabled, is sometimes not only destroyed, but eaten by its companions. One of a school of porpoises at play around a vessel, as we once witnessed, was injured by a pole hurled at it, when it was instantly pursued by dozens of others with a celerity of movement that was astonishing.

Darwin, commenting on this trait in animals, says: "It is almost the blackest fact in natural history that animals should expel a wounded one from the herd, or gore or worry it to death."

That the helpless and suffering should be thus destroyed does indeed seem to indicate an absence of sympathy in strange contrast with the kindness and affection shown in innumerable instances between animals of the same species. But the kind-hearted author already cited remarks that "instinct or reason may suggest the expelling an injured companion, lest beasts of prey, including man, should be tempted to follow the troop. In this case their conduct is not much worse than that of the North American Indians, who leave their feeble comrades to perish on the plains, or the Feejeeans, who, when their parents get old or fall ill, bury them alive."

If the view of Darwin be correct, it is evident that the habit originated in the wild and undomesticated state of the species, and that, in destroying their disabled or wounded ones, they simply act out their instinct of self-preservation.

They get rid of those which might delay their flight or allure pursuit; and we may conclude that love of life and fear of danger, rather than any primal ferocity, develop and fix a habit which at first sight appears singular and unaccountably savage.

Animals in their wild state live in perpetual danger, and, we may add, in perpetual fear. Sir John Richardson observes that wolves continually haunt the track of the buffalo, and the weak are often seized. The peccary, says Cuvier, if it falls in the rear of the flock, is seized by the jaguar, and the feeble, straggling ones of every herd become a prey to its enemies, and incite pursuit. It would be strange, indeed, if this source of danger, so obvious and persistent, should escape the sagacity of animals, or be disregarded by their prudence. We know that animals of many kinds defend each other, and thus protect themselves. The habit referred to is merely a method of defense. The courageous and strong stand guard over the herd or flock in time of danger, and the intelligence or instinct which prompts this also prompts the removal of an element of weakness.

Nor do animals differ in this respect from man. Does history furnish no instances where commanders of armies have sacrificed the wounded, and destroyed by poison or otherwise the weak and helpless that the strong might escape destruction? Equally with animals and with man, danger may suggest and put in execution means for securing safety, which show a strange absence of sympathy in the one case, and of humanity in the other.

It is not probable that animals possess savage qualities other than such as are or were originally of service to them and their kind. We cannot understand that any quality or habit should be developed in an animal which was not serviceable to it; but it is certain that both may arise from the wants and necessities incident to its condition.

If strength and fleetness are essential in pursuit, so also is sagacity in eluding it. An element of danger is detected and removed. A fox will use every precaution that the hound may not be allured by his odor, and the white urus destroys its weak comrade which falls in the rear unable to maintain its place in the flight. The habit with some animals of destroying their weak companions is only one of many which by repetition becomes at last common to the kind. With the repetition of the act grows a disposition or tendency to repeat it as the exciting cause or condition recurs. It becomes thus in the creature a tendency which we may term instinctive, and that such tendencies are transmissible and are inherited needs no illustration here. Perhaps there is no fact in biology more clearly established and more fearfully significant than this, and it is true equally in man and in the lower animals.

Habits thus developed do not readily disappear, but the old disposition or instinct may remain after the habit has been discontinued, and long after it has ceased to be of service to the creature. This is shown by the fact that former habits frequently reappear when suggested by former predisposing conditions, although these may have been long overlooked or forgotten.

Under domestication many habits indispensable to animals in their wild state become useless, and slowly but surely disappear, while others are developed, and the animal undergoes a physical and mental change; but the time is very long before old instincts die out beyond the possibility of resuscitation. They appear to continue in animals under domestication as do those of the savage, in civilized life, despite culture and education. We will illustrate by a single instance:

With the savage, hunting is the occupation of life. He hunts from necessity, and his mental, moral, and physical being, are attuned to its conditions. His hunting habits and hunting dispositions are thoroughly instinctive, but in civilized communities the necessity for hunting has chiefly disappeared. Still, the field and forest are hunting-grounds. The savage is not there, but who will say that the old instincts have not survived in the cunning of pursuit, the thoughtless cruelty of destruction, and indifference to suffering? It is true our modern hunter has grown gentle, humane, and tender, in a thousand directions, but the enjoyment of him who hunts merely for sport cannot be in that spirit which has developed with his culture—which weeps at the sight of agony, and is tender to the “mournful eloquence of pain.”

We refer to this only to illustrate the persistence of instinctive

tendencies, and of the habits with which mental states seem directly associated.

It is, we believe, probable, perhaps certain, that the disposition in some animals to destroy their weak associates has come down from a former undomesticated condition of their kind, in which its correlative habits were essential to safety and life.

If this view be correct, our friend's birds may not be obnoxious to the charge of being specially cruel; and, seeing how persistent instinctive habits may become in some of the higher animals and in man, it is not strange that they continue in the turkey, a species recently domesticated, and by no means remarkable for intelligence.



## THE PRIMARY CONCEPTS OF MODERN PHYSICAL SCIENCE.

BY J. B. STALLO.

### II.—*The Atomic Constitution of Matter as a Postulate of Thought.*

MY inquiry thus far has touched the assertion according to which the atomic hypothesis is the necessary basis of the theories which constitute the sciences of physics and chemistry. I propose now to consider the claim that this hypothesis is an essential prerequisite of the realization of material existence in thought.

To show how pointedly this claim is made, it will be sufficient to extract a passage from a recent lecture of Prof. John Tyndall, before the British Association at Liverpool, "On the Scientific Use of the Imagination" ("Fragments of Science," American edition, p. 135). The words of Prof. Tyndall, whose opinions, by reason of his eminence among physicists, may be taken *instar omnium*, are these:

"Many chemists of the present day refuse to speak of atoms and molecules as real things. Their caution leads them to stop short of the clear, sharp, mechanically-intelligible atomic theory enunciated by Dalton, or any form of that theory, and to make the doctrine of multiple proportions their intellectual bourn. I respect the caution, though I think it is here misplaced. The chemists who recoil from these notions of atoms and molecules, accept without hesitation the undulatory theory of light. Like you and me, they one and all believe in an ether and its light-producing waves. Let us consider what this belief involves. Bring your imagination once more into play, and figure a series of sound-waves passing through air. Follow them up to their origin, and what do you there find? A definite, tangible, vibrating body. It may be the vocal chords of a human being, it may be an organ-pipe, or it may be a stretched string. Follow in the same

manner a train of ether-waves to their source; remembering at the same time that your ether is matter, dense, elastic, and capable of motions subject to and determined by mechanical laws. What, then, do you expect to find as the source of a series of ether-waves? Ask your imagination if it will accept a vibrating multiple proportion—a numerical ratio in a state of oscillation? I do not think it will. You cannot crown the edifice by this abstraction. The scientific imagination, which is here authoritative, demands as the origin and cause of a series of ether-waves a particle of vibrating matter quite as definite, though it may be excessively minute, as that which gives origin to a musical sound. Such a particle we name an atom, or a molecule. I think the seeking intellect, when focussed so as to give definition without penumbral haze, is sure to realize this image at the last."

The import of these sentences is plain. It is that an ethereal or other atom, or a molecule, is related to its vibratory motion just as any ordinary body is related to its movements of translation—as a stellar or planetary body, for instance, is related to its movements of rotation or revolution; and that, just as the conception of the stellar or planetary body of necessity precedes the conception of its rotary or revolutionary motion, so also the conception of the atom or molecule of necessity precedes the conception of the vibratory motion whereof light, heat, electricity, chemical action, etc., are known or supposed to be modes. In other words: to make the existence of matter, such as we deal with in action and in thought, conceivable, we are constrained, according to Tyndall, to assume ultimate material particles as pre-existing to those motions or manifestations of force which are apprehended as light, heat, electricity, chemical action, etc.

In order to preclude all possibility of misunderstanding, it is perhaps well to call attention to the fact that, while Tyndall speaks in terms only of the relation of the ether to its vibratory motion, it is evident from his own language that this is meant as an illustration or exemplification of the relation of all matter to any or all motion whatever.

Now, let us for a moment contemplate an ultimate particle of matter in this state of existence in advance of all its motion. It is without color, and neither light nor dark; for color, lightness, darkness, etc., are luminal affections, and, according to the received mechanical theory of "imponderables," of which Prof. Tyndall is a distinguished champion, simply modes of motion. It is similarly without temperature—neither hot nor cold; for heat also is a mode of motion. For the same reason it is without electrical or chemical properties—in short, it is utterly destitute of all those properties in virtue of which, irrespective of its magnitude, it could be an appreciable object of sense, unless we except the properties of weight and extension. But weight is a mere play of attractive forces; and extension, too, is known to us only as resistance, which in turn is a manifestation of force, and thus a phase of motion. Extension *per se*, abstract extension, cannot

be realized in thought, whatever ground there may be for dissenting from the opinion of Sir W. Hamilton ("Lectures on Metaphysics," Boston edition, p. 385), that "we cannot represent extension to the mind except as colored."

Thus the solid, tangible reality, craved by Prof. Tyndall's "scientific imagination," wholly vanishes from the "seeking intellect" the moment this intellect attempts to grasp it apart from the notion which is said to presuppose it as its necessary substratum. If the deliverances of the scientific imagination are authoritative in science, the notion of the primordial atom must be relegated to the regions beyond the bounds of scientific thought.

There is another and very obtrusive aspect of the atomic theory in which its utter inability to satisfy the demands of the "scientific imagination" has long since been recognized. As I have already shown, the atomic theory, in whatever form it is held, presupposes the separation of the atoms by void, interstitial spaces. The only difference of opinion respecting these spaces is as to their magnitude, the emergencies of the modern theories of heat and light having led to the supposition that even in the case of the purely hypothetical "ether" (which is nothing but a clothes-horse for all the insoluble difficulties presented by the phenomena of sensible material existence—a fagot of occult qualities and *principia expressiva*, whose rôle in the material world at large is analogous to the part formerly played by the *aura vitalis*, and similar phantasms, in the organic world) the interspaces are very great in comparison with the dimensions of the atoms, so that a group of these atoms is not infrequently compared with a stellar or planetary system. Nevertheless, their motions are construed as effects of their mutual attractions and repulsions. But how is the mutual action of atoms existing by themselves in complete insulation and wholly without contact to be realized in thought? We are here in the presence of the old difficulties respecting the possibility of *actio in distans* which presented themselves to the minds of the physicists in Newton's time, and constituted one of the topics of the famous discussion between Leibnitz and Clarke, in the course of which Clarke made the remarkable admission (Fourth Letter of Clarke, § 45, "Leibnitii Opera," ed. Erdmann, p. 762) that, "if one body attracted another without an intervening body, that would be, not a miracle, but a contradiction; for it would be to suppose that a body acts where it is not"—otherwise expressed: inasmuch as action is but a mode of being, the assertion that a body can act where it is not would be tantamount to the assertion that a body can be where it is not. This admission was entirely in consonance with Newton's own opinion; indeed, Clarke's words are but a paraphrase of the celebrated passage in one of Newton's letters to Bentley, cited by John Stuart Mill in his "System of Logic," which runs as follows:

"It is inconceivable that inanimate brute matter should, without



the mediation of something else, which is not material, operate upon and affect other matter *without mutual contact*. . . . That gravity should be innate, inherent, and essential to matter, so that one body may act on another, at a distance, through a vacuum, without the mediation of any thing else by and through which their action and force may be conveyed from one to the other, is to me so great an absurdity that I believe no man, who in philosophical matters has a competent faculty of thinking, can ever fall into it."

The thesis of the impossibility of *actio in distans* has been a standing dogma among physicists ever since the revival of physical science, three centuries ago. Twenty-five years before the publication of Descartes's "*Discours*," it found expression in the axiom of Bartholomew Keckermann ("*Systema Physicum*," Hanau, 1612): "Omnis alteratio fit per contactum;" and Descartes's whole physical system had its root in the proposition that "a body can no more act *where* it is not than it can act *when* it has ceased to be, the principle, *cessante causa cessat effectus*, holding good in either case." It was this "patent absurdity" of material action through empty space which led the greatest mathematicians of Continental Europe (the elder Bernouillis, Huyghens, etc.) to reject the doctrines of Newton's "*Principia*," and induced Leibnitz to construct his system of "cosmic circulations," in which the old Cartesian vortices reappeared in a new dress, and under another name.

The conflict between the theory of distant attraction and the authority of the "scientific imagination" is one of the instances adduced by John Stuart Mill ("*System of Logic*," book ii., chap. v., § 6) in support of his proposition that conceivability is no test of truth, because it is the simple result of familiarity of thought or experience; and he expresses the opinion that "the majority of scientific men have at last learned to conceive the sun attracting the earth without an intervening fluid, and that "the ancient maxim, that a thing cannot act where it is not, probably is not now believed by any educated person in Europe" ("*Logic*," book v., chap. iii., § 3). But Herbert Spencer ("*Principles of Psychology*," ii., 409) justly doubts the truth of this opinion, expressing the belief that "the most that can be said is that they" (the scientific men) "have given up attempting to conceive how gravitation results." How formidable the difficulty under discussion still appears to the minds of physicists at the present day, and how completely the mental predicament of the nineteenth century is identical with that of the seventeenth, is evident from the many recent renewals of the attempt to construe the action of gravity as a case of ethereal pressure or impact. I content myself with the citation of a very characteristic paragraph, written long after the sentences quoted from Mill, in a late article of Prof. Challis "On the Fundamental Ideas of Matter and Force in Theoretical Physics" (*Philosophical Magazine*, § 4, vol. xxxi., p. 467). "There is no other kind of force,"

says Prof. Challis, "than pressure by contact of one body with another. This hypothesis is made on the principle of admitting no fundamental ideas that are not referable to sensation and experience. It is true that we see bodies obeying the influence of an external force, as when a body descends toward the earth by the action of gravity; and, so far as the sense of sight informs us, we do not in such cases perceive either the contact or the pressure of another body. But we have also the sense of touch or of pressure by contact—for instance, of the hand with another body—and we feel in ourselves the power of causing motion by such pressure. The consciousness of this power and the sense of touch give a distinct idea, such as all the world understands and acts upon, as to how a body may be moved; and the rule of philosophy which makes personal sensation and experience the basis of scientific knowledge, as they are the basis of the knowledge that regulates the common transactions of life, forbids recognizing any other mode of moving a body than this. When, therefore, a body is caused to move without apparent contact and pressure of another body, it must still be concluded that the pressing body, although invisible, exists, unless we are prepared to admit that there are physical operations which are and ever will be incomprehensible by us. This admission is incompatible with the principles of the philosophy I am advocating, which assume that the information of the senses is adequate, with the aid of mathematical reasoning, to explain phenomena of all kinds. . . . All physical force being pressure, there must be a medium by which the pressure is exerted."

It is not my purpose, of course, to question the Newtonian doctrine of gravitation, or to urge the adoption of the views of Prof. Challis and others, who seek to show that what seems to be attraction is in reality a propulsion of solid bodies in immediate contact. That the transfer of motion from one body to another by impact is no less incomprehensible than *actio in distans* becomes apparent on a moment's reflection; and that the hypothesis of an intervening "ether"—itself composed of atoms, the interspaces between which are larger in proportion to these atoms than the interstellar spaces—is simply a new presentation of the old perplexity in a worse form, and in no wise helps to remove the difficulties involved in the phenomenon of the correspondence between the movements of two bodies without contact, is equally clear, and has been sufficiently pointed out by Herbert Spencer ("First Principles," p. 59). My object is merely to show that, if the validity of every theory of the constitution of matter is to be tested by our ability to realize it in thought—to bring it clearly before the scientific imagination, to represent it mentally as a distinct image, or whatever may be the form of words in which this requirement is expressed—the atomic theory fails as completely as any other theory of the nature of matter which has ever been propounded.

But what ground is there for the assumption that conceivability is

a test of reality? This question has been the subject of a famous controversy between Dr. Whewell and John Stuart Mill, and of a more recent discussion between Mill and Herbert Spencer. Mill broadly denies that "our capacity or incapacity of conceiving a thing has any thing to do with the possibility of the thing in itself," while Spencer deems it to be a universal postulate of all thought that an inconceivable proposition, i. e., a proposition "of which the terms cannot, by any effort, be brought before consciousness in that relation which the proposition asserts between them—a proposition of which the subject and predicate offer an insurmountable resistance to union in thought"—must necessarily be held to be untrue. My present purpose does not, in strictness, call for a thorough examination of this question; nevertheless, it is desirable that the confusion into which (as is usual in such cases) it has been thrown by the emergencies of the debate should be partially cleared up.

Here, at the outset, it appears to me to be unfortunate that Mill repudiates, and Spencer does not insist upon, a distinction suggested by Coleridge between the *Inconceivable* and the *Unimaginable*, though we may find reason for dissenting from Coleridge's proposition, that "the Unimaginable may possibly be true, but the Inconceivable cannot." It is true, as has been observed by Reid (and after him by Stewart), that "conceiving, imagining, and apprehending, are commonly used as synonyms in our language;" but the distinction above referred to is, nevertheless, both real and important. Mill, indeed, declines to recognize this distinction, not from any deference to the usages of ordinary speech, but by reason of his antagonism to a philosophical system. He is a strict scholastic nominalist, and denies that there are any objects corresponding to concepts in the mind any more than in Nature, for the reason that concepts, being the results of abstraction, are general, while objects can be represented or imaged in thought only as particular. And, having pointed out ("Examination of Sir W. Hamilton's Philosophy," chap. xvii.) that in reasoning we rarely attend to all the attributes of which a concept is said to be the complement, but deal exclusively with more or less of these attributes which we are able to bring separately before the mind by means of names that suggest them, on the principle of the association of ideas, he claims that our reasoning is carried on by means, not of concepts, but of names.

At the first blush, the remark of Sir W. Hamilton, that the war between the conceptualists and nominalists is a mere war of words, would appear to be just. Surely the most inveterate nominalist must admit that the material of our reasoning processes consists, not of the sounds or written symbols composing words, but of the meanings which underlie them. And, roughly stated, concepts are nothing but these meanings. If a concept be, in the language of Sir W. Hamilton, a "bundle of attributes"—as for purposes of discursive reasoning it

undoubtedly is—then every increase or diminution of this bundle is in effect the formation of a new concept; and Mill's objection that we cannot think by means of concepts, because in reasoning we bring before the mind a varying number of the attributes composing them, is seen to be founded on the mistaken assumption that for every object there is but one corresponding concept, the truth being that an object may be represented in thought by concepts without number. For every object is the first link in innumerable chains of abstractions varying in kind and diverging in direction with the comparisons instituted between it and other objects; and each of the links beyond the first is a concept under which the object may, in scholastic phrase, be subsumed. A horse, for example, may be considered *mechanically* as a system of levers and strings, a self-regulating locomotive, a machine, etc., or as a thousand pounds moving at the rate of 2.40 per mile, a heavy body, etc.; or, *chemically*, as a congeries of calcium and magnesium phosphates, carbonates, and fluorids, with albumine, fibrine, and similar substances, as a compound of oxygen, hydrogen, carbon, nitrogen, sulphur, phosphorus, calcium, magnesium, silicon, etc.; or, *zoologically*, as a solipede, an ungulate, a mammal, an animal, etc.; or, *economically*, as a beast of burden, a domestic animal—and so on, indefinitely. The formation of concepts like these is incident to all productive reasoning about individual things, and their fixation by means of language (speaking of language in the comprehensive sense of all symbols by which forms of thought may be represented) an indispensable condition of the progress of scientific knowledge, or, indeed, knowledge of any sort.

On the other hand, the most obstinate conceptualist will not deny that, before any one of these concepts can stand as the representative of an actual, concrete object, it must be supplemented with all those circumstances of singularity or particularity which were left behind in the progress of abstraction.

On closer examination, however, the war of words between Mill and his antagonists proves to be a real contest of principles. The elaboration of the data of experience into concepts implies an establishment of relations between these data in conformity to laws not immediately derivable from this experience itself—a mental digestion of the crude material of sense; and this is, in Mill's opinion, inadmissible in view of the purely sensational origin of all knowledge. Mill has an instinctive horror of every thing which purports to be something else than a deliverance of sense, and contends that in our thought we are at all times conversant, not with abstractions, but with facts. Whether this be true or not, depends upon the meaning of the word "facts," irrespective of the necessary reservation that all the facts about which we know any thing at all are the facts of consciousness. A satisfactory discussion of this topic (to which very valuable contributions have been made by Mr. Ferrier) is beyond the scope of my inquiry;

it is sufficient for my purpose to have it conceded that in thought properly so called, i. e., in those intellectual operations in which the deliverances of sense are digested into that system of ideal forms and relations which we call knowledge, or (what is the same thing) science, we never deal with things as they exist, or are represented as existing, objectively—that we have not, nor can we have, present to our minds the whole complement of phenomena which are the constituents of a material object, but always some one or more of them selected or “abstracted” from the rest; that being so, not only for the reason that all our thought is, in the language of Leibnitz (adopted by Herbert Spencer in the first chapter of his “First Principles”), symbolical, the attributes even of the simplest material object being too numerous to be represented in consciousness at the same time, but for the far weightier reason that our knowledge of the attributes of a material object is never complete. I may say here, incidentally, that, in asserting the abstract nature of thought, I am not taking sides in the interminable controversy between Realism and Idealism, or Presentationism and Representationism; a controversy which would be speedily ended if it came to be thoroughly understood that the phenomena of vision, which, ever since the time of Plato, have furnished nearly all the metaphors for the description of intellectual operations, present but distant analogies of the phenomena of perception, and that the puzzle about mediate and immediate perception is but the common case of the obscuration of a subject by a series of figures meant to illustrate it. In my discussion, I am only generally concerned with the fundamental relation which all our thought about objective reality bears to that reality itself.

There is, of course, no agreement among thinkers as to the nature or even the number of successive steps which lead to the formation of the elements of distinct thought. The terms most commonly employed of late (by those, at least, whose authority commands the most respect, viz., the comparative philologists, who are constrained, by the methods of their own science, to treat psychological questions inductively), to designate those steps, are Sensation, Perception, Representation, and Conception. The first two of these I shall, for the moment, leave wholly out of the account, as not relevant to the present inquiry, it being admitted on all hands that the materials of distinct thought are either representations or concepts. A representation may be generally defined as an exhibition to the mind of the deliverances of sense (if the object be real, or of the phantasy if the object be imaginary), in their empirical order and form—in other words, as a mere mental image of the object; while, in the concept, these deliverances are reduced to unity by the establishment of relations between them other than the relation of their fortuitous concurrence, the concept, at the same time, being made distinct by the establishment of relations between it and the previous concepts of the mind. If I were writing a treatise on

logic, or psychology, these definitions would have to be reduced to forms far more precise; but I purposely refrain from an attempt at exact definition, because I wish to remain on ground common to all who have made the matter in hand the subject of their investigation. For my purpose, it is of little consequence whether or not the distinction here indicated between representations and concepts is accurate and clear; nor is it necessary to determine the exact nature of the relations established in conception between the constituents of a concept, or between the various concepts themselves; it is sufficient to know that both in the representation and in the concept we have in some form a complex of attributes which are ultimately, in the case of material objects at least, traceable to sensible experience, and that the elaboration of representations into concepts involves the establishment of some sort of mental relations between their elements, as well as between the several concepts themselves.

At this point, it is important to guard against a confusion which naturally arises from the fact that logicians and psychologists habitually illustrate the evolution of concepts by examples taken from the abstract sciences. There is a very wide distinction between the relation of a concept to the object of thought in mathematics, for instance, and the corresponding relation between a representation, or concept of a material object, to that object itself. In mathematics, as in all the sciences which are conversant with single relations or groups of relations established (and, within the limits of the constitutive laws of the mind, *arbitrarily* established) by the mind itself, all concepts are exhaustive in the sense that they imply, if they do not explicitly state, all the properties belonging to the object of thought. Not only the constituents of such an object, but also the laws of their interdependence, being determined by the intellect, they may be strictly deduced, each from the other.<sup>1</sup> Thus, a parabola is a line, every point in which is equidistant from a fixed point and a given straight line: that is one

<sup>1</sup> The truth of the proposition that the system of forms and relations, whose discussion constitutes the science of mathematics, is of purely subjective determination, does not involve the assumption (erroneously attributed to Kant, who, on the very first page of his "Critique of Pure Reason," expressly draws the distinction between the "beginning of all knowledge *with* experience," and "the derivation of all knowledge *from* experience"), that the mind is furnished *a priori* with ready-made ideas or concepts; nor is it affected by the circumstance that these forms and relations are ultimately referable to the facts of sensible experience. Mill's refusal to recognize this has betrayed him into writing the extraordinary fifth chapter of the second book of his "System of Logic," in which he questions—albeit falteringly—the necessary truth of the propositions of geometry. The inevitable outcome of this is seen in the writings of Mr. Buckle, who not only boldly asserts that there are no lines without breadth (he strangely forgets the thickness), but also that the neglect of this breadth by the geometrician vitiates his conclusions. His comfort is that the error, after all, is not very considerable. "Since, however," is his language ("History of Civilization in England," ii., 342, Appletons' edition), "the breadth of the faintest line is so slight as to be incapable of measurement, except by an instrument used under the microscope, it follows that the assumption, that there



of its concepts. And in this all the properties of the parabola—that it is a conic section formed by cutting a cone parallel to its sides, that the area of any of its segments is equal to two-thirds of its circumscribed rectangle, etc.—are implied, and from it they may be deduced. Each one of its attributes is an implication of all the others. Our concepts of material objects, on the contrary, are never exhaustive, for their complement of attributes varies with our experience concerning them. These attributes are expressive of the relations between the object and other objects; and, the number of objects being unlimited, the synthesis of attributes is, of necessity, incomplete. And the interdependence of these attributes, as well as the connection between the objects themselves, or their representative images and concepts, has its origin in laws, of which the laws of the intellect are but a partial reflex. It is true that the concept of a material object contains elements whose interdependence is subjective (every intellectual operation, or rather its result, being in some form a synthesis of subjective and objective data); but even these are liable to determination by undigested empirical elements which are present along with them. Moreover, our knowledge of the attributes of a material body is not only imperfect, but these attributes are variable. This is obvious enough in the case of those properties which are usually designated as secondary qualities; every one knows that the thermic, optic, electric, or magnetic conditions of a body change at every moment. But, in fact, there is no property whatever, of a material body, which is strictly invariable, or the law of whose variation is fully known. For this reason, also, the concept of a material object can never expressly, or by implication, be a full complement of its attributes.<sup>1</sup>

can be lines without breadth, is so nearly true, that our senses, when unassisted by art, cannot detect the error. Formerly, and until the invention of the micrometer, in the seventeenth century, it was impossible to detect it at all. Hence, the conclusions of the geometrician approximate so closely to truth, that we are justified in accepting them as true. The flaw is too minute to be perceived. But that there is a flaw, appears to me certain. It appears certain that, whenever something is kept back in the premises, something must be wanting in the conclusion. In all such cases, the field of inquiry has not been entirely covered; and, part of the preliminary facts being suppressed, it must, I think, be admitted that complete truth is unattainable, and that no problem in geometry has yet been exhaustively solved."

Whether Buckle was able to think of a line as the limit between two surfaces, and whether, in his opinion, such a limit has breadth (i. e., is itself a surface, so that we are driven from limit to limit *ad infinitum*), he does not tell us. Nor does he say whether or not, in view of the fact that the breadth of a line depends upon the material out of which it is constructed, or upon which it is drawn, there ought to be a pasteboard geometry, a wooden geometry, a stone geometry, and so on, as distinct sciences.

<sup>1</sup> I do not enter into the question whether or not the use of the word "concept," in reference to material objects, can in all cases be justified, and whether the distinction between representations and concepts is not, in many cases, including the case of "singular concepts," so called, very shadowy. In this connection, it is significant that the Germans use the expression "empirical concept" (*Erfahrungsbegriff*), as equivalent to "representation" (*Vorstellung*).

Bearing this in mind, we shall experience little difficulty in determining the conditions under which the representation and conception of a material object as real are possible. A representation of such an object being an exhibition of the deliverances of sense respecting it, it is plain that nothing can be represented as objectively real, except in terms of experience. And, since our experience is only of the singular and particular, it is also evident that a concept cannot be represented in the mind as objectively real. Thus, matter as such is not a real thing, but a concept; it cannot be "realized" in thought. We can realize, or imagine, or represent as actual, only some one particular thing, with all its accidents of particularity—as of particular dimensions, of a particular color, of a particular temperature, and as being either at rest (i. e., in a state of tension) or in motion. All attempts mentally to represent the reality, in and by itself, of any of the elements into which an individual object is analyzed by the process of abstraction are necessarily futile. The history of speculation is full of attempts of this sort—of attempts to grasp the "thing" as distinct from its properties, the substance apart from its attributes, or, conversely, the attributes apart from their unity, the substance. It is this old error which lies hid in the reasoning of Prof. Tyndall in the passage quoted at the beginning of this article. And the same error lurks in Faraday's endeavor to represent matter as a mere complex of forces. In the one case the properties are imagined to be added to the thing, or the attributes are supposed to be implanted in the substance, as the plums are stuck into the pudding, so that the substance will remain after the attributes are removed; in the other case the substance is looked upon as a mere sum of the attributes—the pudding is thought to be all plums, which not only have a reality by themselves, but which are alone real. That this apparently trivial illustration is entirely apposite, is readily shown by a reference to the grounds upon which Faraday rejects the hypothesis of corpuscular atoms. While the advocates of this hypothesis seek to remove the plums and to retain the pudding, Faraday, on the contrary, takes the plums, and then asks, "Where is the pudding?" "What do we know," he says (Tyndall, "Faraday as a Discoverer," p. 123, American ed.) "of the atom apart from its force? You imagine a nucleus which may be called  $\alpha$ , and surround it by forces which may be called  $m$ ; to my mind, the  $\alpha$  or nucleus vanishes, and the substance consists in the powers of  $m$ . And, indeed, what notion can we form of the nucleus independent of its powers? What thought remains on which to hang the imagination of an  $\alpha$  independent of the acknowledged forces?"

The true root of all these errors is a total misconception of the nature of reality. All the reality we know is not only spatially finite, but limited in all its aspects; its whole existence lies in relation and contrast, as I shall show more at length in the next article. We know nothing of force, except by its contrast with mass, or (what is the same

thing) inertia; and conversely, as I have already pointed out in my first article, we know nothing of mass, except by its relation to force. Mass, inertia (or, as it is sometimes, though inaccurately, called, matter *per se*), is indistinguishable from absolute nothingness; for matter reveals its presence, or evinces its reality, only by its action, its force, its tension or motion. But, on the other hand, mere force is equally nothing; for, if we reduce the mass upon which a given force, however small, acts until it vanishes—or, mathematically expressed, until it becomes infinitely small—the consequence is that the velocity of the resulting motion is infinitely great, and that the “thing” (if under these circumstances a thing can still be spoken of) is at any given moment neither here nor there, but everywhere—that there is no real presence. It is impossible, therefore, to construct matter by a mere synthesis of forces. And it is incorrect to say, with Bain (“Logic,” ii., 225), that “matter, force, and inertia, are three names for substantially the same fact,” or that “force and matter are not two things, but one thing,” or (ib., p. 389) that “force, inertia, momentum, matter, are all one fact”—the truth being that force and inertia are *conceptual constituents* of matter, and neither is in any proper sense a fact. Nor is the ordinary analysis of physical reality into matter + force correct, inasmuch as force is already implied in the term matter. It is an analysis of a thing into two elements, one of which is the thing itself. The true formula of matter is mass  $\times$  force, or inertia  $\times$  force.

We now have before us, in full view, one of the fundamental fallacies of the atomic theory. This fallacy consists in the delusion that the conceptual constituents of matter can be grasped as separate and real entities. The corpuscular atomists take the element of inertia and treat it as real by itself, while Boscovich, Faraday, and all those who define atoms as “centres of force,” seek to realize the corresponding element, force, as an entity by itself. In both cases elements of reality are mistaken for kinds of reality. It is, therefore, sheer nonsense to speak, with Papillon (see the article on the Constitution of Matter in the September number of this journal, p. 553), of a “bare energy, stripped of its material dress;” of a “force in its purest essence, upon which we look as on the marble of the antique, in splendid nakedness, which is radiant beauty too.”<sup>1</sup>

This disposes, in my judgment, of the authority of the “scientific imagination,” in all cases where an attempt is made to determine the constitution of matter. In respect to the general question, however, whether our ability to imagine a thing is decisive of its possible reality,

<sup>1</sup> The translation of the passage from which the above is taken, though on the whole admirable, fails to do justice to the magniloquence of the original, which reads thus: “Toutes ces énergies n'apparaissent à nous à de rares exceptions près que revêtues de cet uniforme qu'on appelle la matière. Une seule de ces énergies se montre dépouillée de ce vêtement et nue. . . . Comment la définir autrement que la force en sa plus pure essence, puisque nous la contemplons comme un marbre antique *dans une superbe nudité* qui est aussi une beauté radieuse.”

it is necessary to add, that this question must be answered in the negative. Whether or not we can imagine, or mentally represent, a thing as real, depends upon the question whether our past experience has furnished us the data for such a representation; and our experience is constantly furnishing us new data.

That the impossibility or difficulty of imagining a thing (which, however, must be carefully distinguished from the absolute impossibility of forming certain concepts, of which I shall presently speak) is no evidence for or against its reality, is a truth of the greatest moment to the student of natural science. Liebig expressed it long ago (*Ann. Pharm.*, x., 179), in the words: "The secret of all those who make discoveries is, that they regard nothing as impossible."

I come now to the conditions of conceivability, strictly and properly so called. These conditions are readily deduced from the incidents in the act of conception to which I have referred. These incidents are: The reduction of the elements of a representation to consistent unity by bringing them into relation, and the establishment of relations between the unit thus evolved and the previous concepts of the mind. A concept can, therefore, be formed, if *a*, its elements, can be united in thought by the establishment of relations between them by which they are reduced to a unit—in other words, if the constituent attributes are consistent with each other—and if *b*, the resulting concept, can be brought into relation, so as to be consistent with the previously-formed concepts of the mind.

Consistency of the constituent attributes with each other, therefore, is the *first*, and consistency of the concept with other concepts the *second*, condition of its successful formation. The first of these is what is known in logic as the law of non-contradiction, or the law of consistency, and is the fundamental condition of all thought. It requires that what is expressly or by implication asserted in the subject shall not expressly or by implication be denied in the predicate of any proposition into which the concept may be resolved, or, in plain words, that what is asserted in one form of words shall not be denied in another.

Now, it is evident that, whenever the formation of a concept involves a violation of the first condition, we have before us a case of absolute inconceivability, and therefore of impossibility. For this condition, as I have said, is the first constitutive law of all intelligence, without which the whole system of relations, in which both subjective and objective realities have their only warrant and support, instantly collapses into the nothingness in which alone all things are identical, and disappears in the night of absolute confusion. No one, not even John Stuart Mill, ever seriously doubted the absolute impossibility of the conception or existence of a round square, or of a straight line which is not the shortest distance between two points. Whenever such a doubt has been expressed, it has arisen from a mental con-

fusion as to the import of the terms employed in the propositions, as we shall see presently in the case of Mill.

But it is otherwise with the second condition of conceivability: that the concept, when framed, shall be consistent with other concepts previously formed. For these latter concepts may be spurious or invalid. Inconceivability arising from non-compliance with the second condition is therefore purely relative, depending on the validity of the concepts with which the concept in question appears to be incompatible. For example, until the discovery of the composition of water, of the true theory of combustion, and of the relative affinities of potassium and hydrogen for oxygen, it was impossible to conceive a substance which would ignite on contact with water, it being one of the recognized attributes of water—in other words, a part of the concept water—that it antagonized fire. This previous concept was spurious, and, when it had been destroyed, the inconceivability of a substance like potassium disappeared. Similarly, we are now unable to conceive a warm-blooded animal without a respiratory system, because we conceive the idiothermic condition of an animal organism to depend mainly on the chemical changes taking place within it, chief among which is the oxidation of the blood, which requires some form of contact between the blood and the air, and therefore some form of respiration. If, however, future researches should destroy this latter concept—if it should be shown that the heat of a living body may be produced in sufficient quantity by mechanical agencies, such as friction—a non-respiring warm-blooded animal would at once become conceivable.

Mill not only refuses to recognize the distinction between what may be conceived and what may be represented in imagination, but he also ignores the distinction between the cases of inconceivability from the one or the other of the two causes just mentioned; and he maintains that all conceivability whatever is relative. The examples which he discusses at length are all cases of inconceivability, and not of unimagibility, and I propose to notice the more important of them in passing. The most noteworthy of these examples is the inconceivability of a round square. In order not to do Mill injustice, it will be best to quote his own language (“Examination of the Philosophy of Sir W. Hamilton,” vol. i., p. 88, *et seq.*, American edition):

“We cannot conceive a round square,” says Mill, “not merely because no such object has ever presented itself in our experience, for that would not be enough. Neither, for any thing we know, are the two ideas in themselves incompatible. To conceive a round square, or to conceive a body all black and yet all white, would only be to conceive two different sensations as produced in us simultaneously by the same object—a conception familiar to our experience—and we should probably be as well able to conceive a round square as a hard square, or a heavy square, if it were not that in our uniform experience, at the instant when a thing begins to be round, it ceases to be square,

so that the beginning of the one impression is inseparably associated with the departure or cessation of the other. Thus our inability to form a conception always arises from our being compelled to form another contradictory to it."

Our inability to conceive a round square due to the fact "that in our uniform experience, at the instant when a thing begins to be round, it ceases to be square," and to the inseparable association between incipient roundness and departing squareness! Whether any one has ever had such experience as is here described, I do not know; but, if he has, I am confident that, even after being reënforced by a large inheritance of ancestral experience in the light of the modern theory of evolution, it will prove insufficient to account for the inseparable association which Mill brings into play. The simple truth is, that a round square is an absurdity, a contradiction in terms. A square is a figure bounded by four equal straight lines intersecting at right angles; a round figure is a figure bounded by a curve; and the oldest definition of a curve is that of "a line which is neither a straight line, nor made up of straight lines."

It ought to be said that there are expressions in the same chapter of Mill's book, from which I have just quoted, which show that the author was very ill at ease in the presence of his own theory. For instance, he says (*ib.*, p. 88): "These things are literally inconceivable to us, our minds and our experience being what they are. Whether they would be inconceivable if our minds were the same, but our experience different, is open to discussion. A distinction may be made which, I think, will be found pertinent to the question. That the same thing should at once be and not be—that identically the same statement should be both true and false—is not only inconceivable to us, *but we cannot conceive that it could be made conceivable.*"

That so clear and vigorous a thinker as Mill should have been capable (especially when he was grappling with the thoughts of a man like Sir W. Hamilton) of writing these sentences, is indeed wonderful. First, he denies that inconceivability is, in any sense or in any case, a test of truth or reality; but then he says it may be otherwise, if the inconceivability itself is inconceivable! That is to say: a witness is utterly untrustworthy; but, when he makes a declaration respecting his own trustworthiness, he ought to be believed!

That the whole theory of inseparable association, as here advanced and applied by Mill, is without foundation, it being impossible, under his theory, to know what the experience of his numerous readers has been, except again by experience which he cannot have had, since most of these readers were utterly unknown to him—that all attempts to argue questions with any one on such a basis are supremely foolish, Mill being bound, by his own doctrine, to accept the answer, "My experience has been otherwise," as conclusive—that this theory is suicidal and subversive of itself, and that every earnest sentence Mill



has ever written is its practical refutation—is too obvious, almost, to require pointing out.

While the example just discussed was a case of absolute inconceivability, the other instances given by Mill are cases of true relative inconceivability. The first is that of antipodes which were long held to be impossible, and are now not only readily conceived as possible, but known to be real. This is true enough, but it finds its explanation, not in the law of inseparable association to which it is referred by Mill, but in the fact that our ancestors held an erroneous concept of the action of gravity. They supposed that the direction in which gravity acted was an absolute direction in space; they did not realize that it was a direction toward the earth's centre of gravity; *downward* to them meant something very different from the sense we attach to that word. With this erroneous concept they could not reconcile the fact that the force of gravity held our antipodes in position as well as ourselves; nor can we. But we have a juster concept of gravity, and the mode and direction of its action; the spurious notion with which the notion of antipodes was inconsistent, has been removed, and the inconceivability of antipodes is at an end.

Similar observations apply to Mill's remaining example (which is to us the most interesting, and that for the sake of which I have carried the discussion of this dry subject to this length) of the inconceivability of *actio in distans*, to which I have already alluded. The true source of our inability to conceive *actio in distans* is, I trust, now apparent. This inability results from the inconsistency of this concept with the prevailing concepts respecting material presence. If we reverse the proposition, that a body acts where it is, and say that a body is where it acts, the inconceivability disappears at once. One of the wisest utterances ever made on this subject is the saying of Thomas Carlyle (quoted by Mill himself in his "System of Logic," in another connection): "You say a body cannot act where it is not? With all my heart; but, pray, where is it?" Of course, a reconstitution of our concepts of material presence, in the sense here indicated, would be in utter conflict with the theory of the mechanical construction of matter from elements which are absolutely limited, hard, unchangeable, and separated from each other by absolutely void spaces. It is significant that nearly all the efficient laborers in the quarries of physical science vaguely feel, if they do not distinctly see, that such a reconstitution is necessary. Such a feeling was at the bottom of Faraday's attempt to construct matter out of the convergence and intersection of mere lines of force, so as to secure to each point of intersection (or, in the language of Faraday, to each centre of force) a virtual omnipresence, the extent of the lines of force being infinite.

I may be permitted to say, at the end of this long but unavoidable excursion into the regions of logic and psychology, that the doctrine, according to which there is no warrant for the deliverances of our

consciousness except the cumulation of purely sensational experience, which not only *may* but *must* vary with the position of the intellects interpreting it—that truth, therefore, is nothing but the inveteracy of error—is the dreariest creed ever promulgated; and its association with the many noble truths of which John Stuart Mill has been the discoverer or the champion, is the most unfortunate “inseparable association” established in recent times. And it is deplorable that Herbert Spencer, who has the merit of being one of the most energetic fumigators of the intellectual atmosphere of our time, should evince a disposition to make concessions to such a creed, and endeavor to eke out its shortcomings by the doctrine (in itself, no doubt, both sound and fertile) of the inheritance of ancestral tendencies of the mind. His own theory leads to conclusions utterly subversive of Mill’s doctrine; for, if organic life (including the life of the mind) has been continuously evolved from inorganic matter, then the lines of our ancestry run into all the phenomena of the material world, and the order of these phenomena must be ingrained, not only in the structure of our bodies, but also in the constitution of our minds. Or, to express it in the language of modern comparative psychology: the ancestral inheritance of our intellects must embrace, not only the associations established by experience between the phenomena of consciousness in the minds of our progenitors, but also the regularity in the evolution of the natural events which gave rise to these phenomena—the laws of Nature. These laws must, therefore, in a certain sense, be prefigurations of the forms of our intellect, so that, after all, there is truth in the sentence of Protagoras, that man is the measure of all things, and sense in the words of Goethe (almost identical with a passage in Plotinus), that the eye sees the light, because it is of solar nature. I do not, of course, mean to stand committed to this argument in the form in which it is here presented, not entertaining the notions respecting the relations between organic and inorganic forms which underlie it, and doubting that the continuity of the evolution of these forms is truly represented by current beliefs. But, with the proper modification of its premisses (which, however, cannot be affected by a few verbal definitions), I believe the argument in favor of the *a priori* sanity of the human intellect to be valid, in spite of certain structural fallacies resulting from the laws of its growth, which I shall have occasion to discuss in my next article; and I further believe the primordial correspondence between the intellect and its objects to be entirely consistent with the theory of evolution, Max Müller to the contrary notwithstanding.

## SKETCH OF MR. J. N. LOCKYER, F. R. S.

THE subject of this notice, Mr. JOSEPH NORMAN LOCKYER, is a young astronomer who has cultivated his science assiduously, and made his mark as an investigator in the field of solar physics. He was born on the 17th of May, 1836, at Rugby, in Warwickshire, England. He inherited from his father a predilection for scientific studies; for, if the elder Lockyer had not the honor of being the first, he was one of the first who contrived methods of telegraphing by electricity.

At a very early age, young Lockyer was deprived of his parents, and, after attending one or two private schools in England, where he picked up the first rudiments of his education, the orphan boy went abroad, and there continued his studies for several years. Upon his return to England, he obtained a position under government, in the War-office, the duties of which have occupied him regularly for the past sixteen years; his astronomical and literary work having been performed in the intervals of time snatched from the government service. In 1858, he married an accomplished and intelligent lady, who not only sympathized with him in his scientific pursuits, but has also shared his work and rendered the most valuable assistance in various of his undertakings.

In 1862, he contributed a very important paper to the memoirs of the Royal Astronomical Society, on the planet Mars, giving the results of his telescopic observations on the physical conditions and configuration of its surface. In 1865, in conjunction with Thomas Hughes, the popular author of "Tom Brown at Rugby," he was appointed editor of the army regulations, and placed upon an improved basis the system of War-office legislation. In 1865, in recognition of his services as an astronomical observer, he was elected a Fellow of the Royal Astronomical Society.

Solar observations had for some time attracted much of Mr. Lockyer's attention, and in that year he propounded his method for observing the grand solar phenomena of the red flames with the spectroscope at any time when the sun is visible, whereas previously it had been impossible to see them except under the obscuration of a total or annular eclipse. A more powerful spectroscope than any then available was needed to solve this problem, and, at Mr. Lockyer's solicitation, the Royal Society made a grant for this purpose. Vexatious delays occurred in the construction of the instrument, and he did not get it until two years later. The idea, however, proved successful, and Mr. Lockyer made the brilliant discovery in which he had been so long baffled for lack of means. He sent the account of it to the French Academy, and his note had been hardly read, when news came

that the French astronomer Janssen, then in India, had made the same observation two months before. The independence of these discoveries was recognized, and the French Academy struck a joint medal in honor of them.

Mr. Lockyer has prosecuted his spectroscopic researches on the sun with great industry and fruitful results, and, in conjunction with Prof. Frankland of the Royal School of Chemistry, has made a series of interesting experiments on the relation of gases under pressure to the spectrum lines, thus throwing important light on the changes taking place in the solar atmosphere.

Mr. Lockyer's contributions to scientific literature, as an author of books, a periodical writer, and a scientific editor, have been numerous. In 1862, he had editorial charge of the scientific department of *The Reader*, and subsequently edited the English edition of "The Heavens," by Guillemin. In 1868, he published his excellent school treatise on "Elementary Astronomy," and in 1869 became the editor of *Nature*, when that able scientific paper was established by Macmillan & Co. Last year "The Forces of Nature," an elaborate work, by the author of "The Heavens," appeared, with amendments and additions from his pen. He has published, during the present year, an excellent little volume on "Spectrum Analysis," being a course of lectures delivered in 1869, and revised to date. It is beautifully illustrated, and forms the first of Macmillan's "Nature Series."

In 1870, he was appointed by the English Government chief of the expedition sent out to Sicily for the purpose of observing the solar eclipse, and, in addition to his other work, accepted the secretaryship of the Royal Commission on Scientific Institutions and the Advancement of Science. In 1871, having been named assistant commissioner, he was requested to draw up a report on science-teaching in English and Continental schools, and the same year he received the honorable appointment of Rede Lecturer at Cambridge.

Mr. Lockyer is a gentleman of courteous and affable manners, a vivacious conversationist, and a ready and fluent public speaker. Like many other scientific Englishmen, he recognizes that he owes a duty to this country, and hopes to be able to discharge it when he can get release from his multifarious engagements. He has been invited by the Lowell Institute to give a course of astronomical lectures in Boston, and, when he comes to deliver them, he will probably repeat the series in some of the other cities of the country.

## EDITOR'S TABLE.

*THE RELATIONS OF BODY AND MIND.*

THE question of the relation of the mental and the corporeal powers has always had a deep speculative interest; but, as science is gradually working it out, it is found to have also a profound practical interest. It is strange that a subject of such fascination, and concerning which so much has been said in all ages, should be so late in its rational elucidation. But, besides the difficulties which spring from its extreme complexity, the inquiry has been perpetually hindered by prejudice and passion. Singular as it may appear, the acquisition of the most important of all knowledge, that of the human constitution by dissection, has been held as a crime until the present generation. The prejudice that led to this result led also to the further result that the most important part of the human system, that which is specially devoted to psychical ends, has been considered last. The early anatomists refrained from dissecting the head for fear of committing impiety, and there remained, long after, a kindred feeling against the analysis and study of the brain. Even when it had been demonstrated, and was admitted by all physiologists, that the brain was the organ of the mind, there still lingered with many a belief that it was a sort of unaccountable, half-superfluous appendage to the body, with no such reason for its existence as was obvious in the case of other anatomical parts. Physiologists might show that it had special relations with the mind, but the students of mental philosophy denied that it was of any importance to them, and proceeded with their inquiries as if it had no existence at all. Buffon described the brain as consisting of a kind of "ignorant mucilage," and the

Rev. F. W. Robertson expressed the general metaphysical and theological contempt for it by ridiculing the idea of accounting for mental effects "by a few ounces more or less of the hasty-pudding contained within the skull." We are indebted to the phrenological school for having made a vigorous fight in behalf of the claims of the head upon the students of mind, and, whatever may be the imperfections of their scheme, they have certainly cleared away a vast amount of prejudice in the popular mind, and prepared for the consideration of the material apparatus in connection with mental phenomena.

It is now well established that, in the study of mind and character, the physiological organism is not only to be taken into account, but is to be made the basis of investigation. Metaphysical treatises open with a description of the nervous system, even if it plays no part in the subsequent exposition. But, wherever mind is studied with a view to practical ends, it is found necessary not only to admit in a general way the intimate dependence and close interaction of the mental and corporeal systems, but the relations have to be worked out with the utmost detail on both sides. In dealing with abnormal mental manifestations, as in the numerous forms of insanity and the various grades of feeble-mindedness, or with the psychological effects of stimulants and narcotics, or with the development and decline of the mental powers, or with the effects of mental overwork and exhaustion, it is now admitted to be indispensable to start from the nervous system, and to regard mental manifestations as conditioned by its properties and laws. Thus far it is only physicians, compelled

by the exigencies of practice, and prepared with the requisite physiological knowledge, who thoroughly accept this point of view, but it is the point of view that must yet be taken by all who deal with the phenomena of human nature on the basis of real and applicable knowledge. Especially in that profession which aims to direct the development of the mind and character of the young, must the corporeal side of their nature be thoroughly and systematically studied. We lately heard of a professor, high in honor and reputation as a teacher of teachers, whose text-books of mind are the metaphysical treatises of Stewart and Hamilton, and who strenuously denies that corporeal considerations have any right to be imported into the question: happily, the class to which he belongs is fast passing away. He who aspires to the noble work of developing a human being must take the whole nature of that being into account. He has no right to cleave it asunder and throw away one part of it, especially that part which is the organism of life, and brings the individual into relation with the universe. The teacher who has only attained an intellectual comprehension of certain branches in which he is to give instruction, has hardly entered upon his preparation. As we have elsewhere written: "Education is an affair of the laws of our being, involving a wide range of considerations—an affair of the air respired, its moisture, temperature, density, purity, and electrical state in their physiological effects; an affair of food, digestion, and nutrition; of the quantity, quality, and speed of the blood sent to the brain; of clothing and exercise, fatigue and repose; health and disease, or variable volition and automatic nerve-action; of fluctuating feeling, redundancy and exhaustion of nerve-power, sensuous impressibility, temperament, family history, constitutional predisposition, and unconscious influence; of material surroundings,

and a host of agencies which stamp themselves upon the plastic organism and reappear in character."

The latest contribution to the literature of this subject is a little book entitled "Mind and Body: the Theories of their Relation,"<sup>1</sup> by Prof. Alexander Bain, author of "The Senses and the Intellect," and "The Emotions and the Will." The volume that now appears represents the leading facts of the question, and their latest theoretical interpretations, and closes with an interesting review of the course of past speculation upon the subject.

It being now established that the brain is the material instrument of the mind, the questions are inevitable, What do we actually know, and how much is it possible to know, of the conditions of this union? It is not enough to recognize that when the circulation of the blood in the brain is arrested, as in fainting, consciousness ceases, nor that alcohol in its influence upon the nervous system modifies mental action in one way, and opium and hashish in other ways; that which we require to understand is, in what manner the mechanism and action of the brain are specially related to the mechanism and action of the mind. Nor is the question as to the ultimate nature of mind and matter, or *how* they can exist together, for this is beyond the province of science to determine. What are the essence of mind and the essence of matter, and whether they are at bottom two things or one thing, are beyond ascertainment, and will prob-

<sup>1</sup> This is number IV. of "The International Scientific Series." In arranging the works of this series, which aims to represent the latest result of thought, it was deemed important that the new psychology should be fully treated, and by the most competent men. Prof. Bain was accordingly engaged to deal with the more general and philosophical aspects of the subject, while the volume of Dr. William B. Carpenter, in the same series, will be a regular practical text-book of mental philosophy from the physiological point of view. It will be issued in January, under the title of "The Principles of Mental Physiology: with their Applications to the Training and Discipline of the Mind, and the Study of its Morbid Conditions."



ably ever remain so. The nature of the union is a mystery, just as the nature of the union between gravity and matter is a mystery; in both cases we investigate only the laws of the phenomena. As the problem is one of the connection between two systems of action, the first step toward its solution must be to resolve these two systems into their simplest elements. The structural elements of the nervous system are marvelously simple; they consist of microscopic cells and fibres, the former being seats or centres of force, and the latter being the means of transmitting it.

Cells and fibres are the instruments of mental action, and, exactly as we rise in the scale of intelligence in animated creatures, there is an increase in the mass of the nervous centres—that is, a multiplication of the nerves and fibres which constitute them. In man, the most intelligent of the animal series, the organ of intelligence is relatively very large, and attains the highest degree of complexity.

Prof. Bain represents the nervous elements of the human brain as follows: "The thin cake of gray substance surrounding the hemispheres of the brain, and extended into many doublings by the furrowed or convoluted structure, is somewhat difficult to measure. It has been estimated at upward of 300 square inches, or as nearly equal to a square surface of 18 inches in the side. Its thickness is variable, but, on an average, it may be stated at one-tenth of an inch. It is the largest accumulation of gray matter in the body. It is made up of several layers of gray substance divided by layers of white substance. The gray substance is a nearly compact mass of corpuscles of variable size. The large caudate nerve-cells are mingled with very small corpuscles less than the thousandth of an inch in diameter. Allowing for intervals, we may suppose that a linear row of 500 cells occupies an inch, thus

giving 250,000 to the square inch for 300 inches. If one-half of the thickness of the layer is made up of fibres, the corpuscles or cells, taken by themselves, would be a mass one-twentieth of an inch thick, say 16 cells in the depth. Multiplying these numbers together, we should reach a total of 1,200,000,000 cells in the gray covering of the hemispheres. As every cell is united with at least two fibres, often many more, we may multiply this number by four for the number of connecting fibres attached to the mass, which gives 4,800,000,000 fibres."

Now, in saying that such a wonderful organism as this is the seat and embodiment of the mind, we require to give distinctness to our conceptions, and are compelled to regard the connected cells and fibres as the simple instruments of simple mental processes as the whole fabric is the organ and measure of the whole mind. The corporeal elements are cells and fibres—what are the psychical elements in their lowest analysis? The old division of of the mind into faculties—as reason, judgment, memory, and imagination—is insufficient, for these are far from being ultimate elementary processes, but are rather the most complex actions of the collective forces of the intelligence in different modes of exercise. The later psychology resolves all these so-called faculties into a few constituents which form, if we may so speak, the contexture of the intellect. As Prof. Bain remarks: "We have no power of memory in radical separation from the power of reason or the power of imagination. The classification is tainted with the fault called in logic 'cross-division.' The really fundamental separation of the powers of the intellect is into three facts, called: 1. Discrimination, the sense, feeling, or consciousness, of difference; 2. Similarity, the sense, feeling, or consciousness, of agreement; and, 3. Retentiveness, or the power of memory or ac-

quisition. These three functions, however much they are mingled in our mental operations, are yet totally distinct properties, and each the groundwork of a different superstructure. As an ultimate analysis of the mental powers, their number cannot be increased or diminished; fewer would not explain the facts, more are unnecessary. They are the intellect, the whole intellect, and nothing but the intellect."

This resolution of the intellect into ultimate discriminations of likenesses and differences among things recognized, remembered, and thought about, and, as a consequence, the growth or development of the intellect as a successive combination and recombining of these relations of discrimination, is an immense step forward in the progress of scientific psychology, because it first brings into close correspondence the two orders of activity. Instead of merely wondering at the brain as an inexplicable mass of mucilage, we now regard it as an organism built up with exquisite delicacy out of thousands of millions of cells and fibres, with myriads of intimate connections, all guarded most securely and put into multiplied and marvelous relations with the external universe. It is impossible here to go into the details of the subject, and we have aimed only to state the present attitude and tendency of psychological inquiry, which is briefly this: Our feelings and volitions, aptitudes and acquisitions, are elements of mind having their corporeal side which it is both indispensable and possible to understand—great progress having been recently made in the investigation. Much in the relations of the cerebral structures to mental action is still profoundly obscure, but much is also already known which is of the highest service for useful guidance. Metaphysics has been hitherto proverbially barren, because it has insisted upon considering mind as an

isolated abstraction; while modern psychology, by regarding the whole nature as a unity, promises, on the other hand, to be eminently productive of practical results.

---

*MEETING OF THE BRITISH ASSOCIATION.*

THE British Association for the Advancement of Science commenced its forty-third session September 17th, in the town of Bradford. Dr. Carpenter resigned the presidency, and, as the health of Dr. J. P. Joule, his successor-elect, did not allow him to assume the duties of the chair, it was taken by Prof. Williamson, the eminent English chemist, who devoted his inaugural address to the discussion of his own department of science. After a handsome tribute to the memory of Liebig, Prof. Williamson entered into an exposition of the present conditions of chemical science, the directions of its greatest activity, the present state of chemical theory, and the general relations of scientific education to the advancement of knowledge. The whole paper is able, but it did not arrive in time for publication in the present number of the MONTHLY.

The chairman of the biological section was Prof. Allman, the distinguished zoologist of the Edinburgh University, and his address, upon taking the chair, seems to us a very able and instructive scientific discussion. But what is the British Association for the Advancement of Science about, in putting at the head of its biological branch a man who favors Darwinian notions, and is consequently a sham scientist? Do they not know that from the Yankee Vatican has gone forth a bull which excommunicates them and their seed to the end of time? In his lively address before the Free Religious Association, in Boston, last May, Colonel Higginson apologized for the extent of theological disagreement by

pointing out the diversities of scientific opinion, and remarked: "I heard one of the greatest scientific men in America reply, when somebody said, 'You must at least admit that there is a division of opinion among scientific men in regard to the doctrines of Darwin,' 'No, there is no difference of opinion among scientific men.' 'Why not?' 'Because,' said he, 'no man who supports the doctrines of Darwin is entitled to be called a scientific man.'" As to who the great man was who made this destructive remark, nobody will need to guess twice; but it squelches Prof. Allman, and turns the British Association out-of-doors as a lot of mere scientific pretenders, for their representative biologist aired his vagaries as follows: "I have thus dwelt at some length on the doctrine of evolution, because it has given a new direction to biological study, and must powerfully influence all future researches."

Prof. Allman regards the doctrine of evolution as a great and actual truth of Nature, still obscured and embarrassed by many difficulties, and in this he is at one with its oldest and strongest adherents; but he insists that it harmonizes and explains so extensive a range of facts, which are without explanation on any other view, as to become invaluable as an instrument of scientific research. On this point he says:

"The hypothesis of evolution may not, it is true, be yet established on so sure a basis as to command instantaneous acceptance, and for a generalization of such wide significance no one can be blamed for demanding for it a broad and indisputable foundation of facts. Whether, however, we do or do not accept it as firmly established, it is, at all events, certain that it embraces a greater number of phenomena, and suggests a more satisfactory explanation of them, than any other hypothesis which has yet been proposed. . . .

Or, finally, is the doctrine of evolution only a working hypothesis which, like an algebraic fiction, may yet be of inestimable value as an instrument of research? For, as the higher calculus becomes to the physical inquirer a power by which he unfolds the laws of the inorganic world, so may the hypothesis of evolution, though only an hypothesis, furnish the biologist with a key to the order and hidden forces of the world of life. And what Leibnitz and Newton and Hamilton have been to the physicist, is it not that which Darwin has been to the biologist?" Only to think of it! Would it not have been well if those British scientists had got some American to teach them what science is, and how to preserve it from perversion and degradation?

---

PROFESSOR CZERMAK.

OUR readers will recall an important lecture on "Hypnotism in Animals," a translation of which, by Miss Hammond, appeared in THE POPULAR SCIENCE MONTHLY for September. It gave some of the results of a very interesting research in comparative psychology; and, in a second lecture upon the same subject, in the present number, the results of the investigation are continued, with some strictures on the so-called experimental investigations of "spiritualism." The originality of this inquiry, and the practical lesson that is drawn from it, will be sufficient to secure a careful perusal of these discourses, but the reader's interest in them will be increased by the painful announcement of the recent death of their distinguished author, which occurred September 15th. Prof. Czermak was the head, and in fact the proprietor, of the famous Physiological Laboratory in Leipsic, where he lived. He was the inventor of the laryngoscope, and his treatise upon it was translated and published by the Eng-

lish Sydenham Society. He was a man of large wealth, which he liberally devoted to the work of science by maintaining his physiological school; and, besides being a skillful and able investigator, he was a man of enlarged culture and earnestly sympathetic with all measures and movements for the diffusion of valuable knowledge among the people. He was warmly interested in carrying out the project of the "International Scientific Series," being a member of the German committee to decide upon the contributions from that country; and, had he lived, he would have prepared a volume for the series himself. He wrote and spoke the English language with ease and elegance, and his wife conversed in it so fluently and perfectly that the writer felt sure she must be an American lady, if not English, until he learned that she had never been out of Germany. Prof. Czermak died of a lingering disease from which he had long suffered.

#### MR. PROCTOR'S LECTURES.

MR. RICHARD A. PROCTOR, the eminent English astronomer, is to lecture in this country during the ensuing season. We need hardly say that he is a first-class man, and stands among the ablest in his chosen department of science. Nor is he a mere recipient and reporter of other men's ideas; he has views of his own, and has made his independent contributions to the extension of astronomical science. But it is as a lucid and attractive writer on astronomical themes that Mr. Proctor is chiefly known. He has written an elaborate work on "The Sun," and has just published a corresponding volume on "The Moon;" these, with "Other Worlds than Ours," and his numerous and excellent papers in the reviews on stellar astronomy, show his thorough familiarity with the whole field of celestial phenomena. Mr. Proctor is said to be a clear, rapid, and forcible speak-

er, which, with his illustrations, will make his lectures the leading scientific entertainment of the season.

## LITERARY NOTICES.

THE PHILOSOPHY OF EVOLUTION. (An Actonian Prize Essay.) By B. THOMPSON LOWNE, M. R. C. S., F. L. S. London, John Van Voorst.

HANNAH ACTON, relict of Samuel, had opinions. In this there was certainly nothing remarkable, but she had also that which gives dignity and power to opinion, that is, money to back it. Ideas amount to very little until incarnated, and then they acquire an immense and lasting influence. A narrow-minded blockhead may cherish views that nobody regards as worth listening to, but if he puts a few hundred thousand dollars behind them, and founds a college for carrying them out, they suddenly rise into respectability, and are made potential for generations. Our friend Hannah had a notion that there prevails a very low estimate of the wisdom and goodness of the Creator of the universe, and she was willing to spend money to raise the standard, so she placed a thousand pounds of good solid investments in the hands of a committee of the Royal Institution of Great Britain, to appropriate the interest, every seven years, in the shape of a prize of one hundred guineas, for the best essay, "illustrative of the wisdom and beneficence of the Almighty, in such department of science as the committee should select," leaving it to their discretion to withhold the reward if none of the essays produced were thought worthy of it. Seven years ago, the solar radiations—certainly a magnificent subject—was proposed for a prize; but, as nothing appeared upon that theme which would to any extent promote the donor's intention, the money was not granted. So the funds accumulated, and this year two prizes were offered, one of them for the best essay on the "Law of Evolution, as illustrating the Wisdom and Beneficence of the Almighty," and B. Thompson Lowne got the golden prize for writing the little book before us. The fact is notable as showing the advance of thought, for no transformation suggested by the evolutionists as taking place among the lower animals

is more surprising than that transformation of opinion in the scientific world that has made such an award as this possible; and, if Aunt Hannah had been as prophetic as she was devout, and scented afar the use that would be made of her money, it is questionable if the Royal Institution would ever have got a shilling of it. As for the book itself, it is but a sorry performance. It has been sagely remarked, concerning prize sheep and prize essays, that the former are useful only for making candles, and the latter for lighting them; and the observation is as true of Mr. Lowne's book as of the class to which it belongs, for it is certainly the poorest piece of work upon the subject that we have yet seen. Most contributions to this question are inspired by such an interest in it as to enforce study and secure some merit; but this contribution has obviously been made for a hundred guineas. Literary labor need not be necessarily bad because it is paid for, but prize essays are an open appeal to mercenary motives, and are apt to attract those who are mainly influenced by them. Mr. Lowne undoubtedly knows something of his subject, but he neither contributes any thing to its original thought, nor, what was equally needed, has he given us a clear and full popular representation of it. The book which shall perform that office remains yet to be written.

**ELEMENTS OF PHYSICAL MANIPULATION.** By EDWARD C. PICKERING, Thayer Professor of Physics in the Massachusetts Institute of Technology. 8vo. 225 pages, price, \$3.00. New York: Hurd & Houghton.

THERE are hopeful signs that the despotic rule of the verbal system in education has had its day, and must lose its supremacy in future exactly in the ratio of the advance of thorough scientific education. Nothing can be more futile than the mere verbal teaching of physical laws, when it is possible, by the performance of simple experiments, to bring their operation directly before the student's mind. It is quite as preposterous as the prevailing habit of learning the descriptive and observational sciences by memorizing the statements of books rather than by the direct study of the objects themselves. That nine-tenths of the school-study of science is at present

an unmitigated educational sham but few will deny, and what is now wanted is less an increase in the amount of scientific study than a radical amendment of its method. This want is widely felt, and is beginning to be efficiently supplied. Botanical and zoological text-books are becoming more and more guides to Nature, and there is springing up a separate literature of working processes in the experimental sciences. Treatises on manipulation have long been standard necessities in chemical laboratories, and they are now recognized as of equal importance in laboratories devoted to other departments of experimental science. The admirable volume of Drs. Burden-Sanderson and Michael Foster, on "The Processes and Manipulations of the Physiological Laboratory," is a recent English contribution in this direction; and the "Introduction to Physical Measurements," by Dr. F. Kohlrausch, of Darmstadt, the translation of which has just been issued by Churchill, of London, is a valuable volume of the same kind. Prof. Pickering's new book, however, is now by far the best guide that we have for the practical teaching of natural philosophy. Assuming that the instruments are in the hands of the student, it shows him precisely how to use them, what precautions to take, and what errors to avoid. "It is intended as a hand-book for teachers, for the large class of amateurs who devote their leisure to some branch of physical inquiry, and more particularly as a text-book for the physical laboratories now introduced so generally in all our larger colleges and scientific schools.

"It is hoped that it may also aid the introduction of the laboratory system into the high-schools and academies, as many of the experiments are simple enough to be performed there, and, at the same time, the kind of apparatus described is such that it can be made at very small expense."

The preliminary chapter is devoted to general methods of investigation and the more common applications of the mathematics to the discussion of results, and a short description is also given of the various methods of measuring distances, time, and weights, which, in fact, form the basis of all physical investigation. The remain-

der of the volume is occupied with a series of experiments upon the following general topics: the mechanics of solids, the mechanics of liquids and gases, and the phenomena of sound and light. The work is written in a clear style, is neatly and fully illustrated, and is the result of four years' practical experience in the physical laboratory of the Massachusetts Institute of Technology. It is gracefully dedicated to Prof. William B. Rogers, the founder of that institution, "as the first to propose a physical laboratory." The rapid spread of the laboratory system of teaching physics in the higher schools of this country will open a wide field of usefulness for Prof. Pickering's excellent text-book.

#### CIVILIZATION CONSIDERED AS A SCIENCE.

By GEORGE HARRIS, F. S. A. 382 pages.  
Price, \$1.50. D. Appleton & Co.

ALTHOUGH the author of this volume is a lawyer, and is disposed to consider his subject very much in the light of his professional studies, that is, from the standpoint of the moral sciences, yet he accepts the broader view which regards civilization as part of the order of Nature, and as, therefore, dependent upon many sciences for its interpretation. His aim, however, is not purely scientific, that is, to analyze and generalize the phenomena of civilization; but, recognizing the government of natural law, he rather attempts a practical discussion of those agencies of civil and social advancement which are most perfectly under public control. He writes with a view to the improvement of society, rather than to the understanding or explanation of it, and his book would have been more completely described by the title "Civilization considered as a Science and an Art." Mr. Harris first inquires into the essential constitution of civilization, to determine what are its factors or the various forces and instrumentalities that have coöperated in its development. Individual enterprise, scientific discoveries and inventions, education, legislation, internal and external intercourse, religious institutions, language and literature, and racial, climatic, and geographical conditions, are all enumerated as elements of the grand result, while the various values of these several elements are considered in the successive chapters

of the book. The present work is a new and revised edition of a volume that appeared several years ago. The result of his progressive studies has been, materially to modify the author's opinions on points at first held to be all-important. He at first considered that legislative measures, expressly adapted for the purpose, are the main means by which civilization has been promoted; but a careful examination of the subject soon sufficed to correct this error. The subtler and more pervasive influence of education was next fixed upon as "constituting the real efficient cause, if not the actual essence of civilization." But further inquiry convinced the author that here also he was so profoundly wrong that he regards the refutation of this fallacy as the main purpose of his work. He says: "Upon taking a comprehensive view of the whole matter, in all its different bearings, and with regard to all its varied requirements, the ultimate conclusion which I arrived at was, that which is not only really needed, but what is, in fact, in many cases, actually intended in the demands for the intellectual and moral improvement and advancement of the nation, is not education merely, but civilization generally. This principle, which has not been adopted without the fullest deliberation and the sincerest conviction of its truth, is the basis of the doctrine propounded in the following pages, and its recognition is deemed of the utmost consequence to the well-being of society. Education is, in fact, so to speak, one only out of several of the chains by which the car of civilization is drawn onward. By applying to this one alone, not only is the machine moved very feebly and very slowly, but there is considerable danger incurred of snapping the single chain."

Mr. Harris puts forth no claim to the discovery or extension of the scientific theory of civilization, but his book contains much information and many important suggestions upon the subject.

THE LOGIC OF ACCOUNTS; a New Exposition of the Theory and Practice of Double-Entry Book-keeping. By E. G. FOLSOM, A. M. Price \$2.00. A. S. Barnes & Co.

THERE are two kinds of school-books upon the same subjects. One is written from the art point of view, and the other



from that of science; one deals with rules and rote, and the other with principles; one narrows, the other widens; one makes of a student a good machine, the other an educated thinker. Mr. Folsom's book-keeping is to be commended on broad educational grounds, as it presents the subject in its logical and scientific form, suitable for liberal mental training. The difficulty with book-keeping, as with arithmetic, is that, under pressure of the utilitarian spirit, they are degraded into mere blind mechanical operations, acquired as a kind of dexterity, and solely with a view to business. Book-keeping is commonly learned in much the same way as the management of the sewing-machine, and to little better purpose, so far as mental cultivation is concerned. Mr. Folsom aims to redeem the study to its higher uses by treating it as a science of values and exchanges, which depends upon reasons and laws. While making due provision for the practice of the art, his constant method is to keep in view the principles which should guide the student's thinking. A work like this, pursued thoughtfully and thoroughly, in its philosophic spirit, will afford the most valuable preparation for studying the science of political economy, which treats of the laws of value and exchange as affecting communities and nations on the largest scale.

**ANTIQUITIES OF THE SOUTHERN INDIANS, PARTICULARLY OF THE GEORGIA TRIBES.** By CHARLES C. JONES, Jr. Large octavo, 532 pages, illustrated with Thirty-one Plates, and several Woodcuts. Price \$6.00. New York: D. Appleton & Co., 1873.

WE have before briefly noticed this valuable contribution to American archæology, and now proceed to give our readers a further account of it, as, since the publication of the "Ancient Monuments of the Mississippi Valley," no work has been written upon this subject so minute in its details, so careful in statement, and so extended in its observations. Although the antiquities of Georgia claim the author's particular attention, he presents an intelligent and comprehensive view of the ancient monuments and aboriginal relics of that portion of the territory of the United States which is bounded on the north by Kentucky and the upper

limits of Virginia, on the east by the Atlantic Ocean, on the south by the Gulf of Mexico, and on the west by the Mississippi River. The field of research—which is manifestly one of great interest, abounding with relics of unusual variety, symmetry, and beauty—has hitherto been but feebly explored. Here, in ancient times, dwelt peoples who apparently occupied a middle position in the scale of semi-civilization; influenced, on the one hand, to a greater or less degree, by those ideas which in Mexico and Central America culminated in such complex and elaborate developments, and, on the other, sympathizing with and sharing in those ruder expressions characteristic of Western hunter tribes and their more northern neighbors.

"Our object has been," says the author in his preface, "from the earliest and most authentic sources of information at command, to convey a correct impression of the location, characteristics, form of government, social relations, manufactures, domestic economy, diversions, and customs of the Southern Indians, at the time of primal contact between them and the Europeans. This introductory part of the work is followed by an examination of tumuli, earthworks, and various relics, obtained from burial-mounds, gathered amid refuse-piles, found in ancient graves, and picked up in cultivated fields and on the sites of old villages and fishing-resorts. Whenever these could be interpreted in the light of early-recorded observations, or were capable of explanation by customs not obsolete at the dawn of the historic period, the authorities relied upon have been carefully noted."

In the first four chapters we are made acquainted with the political, social, and industrial status of the Southern Indians, as disclosed by the narratives of the Spanish expeditions, and portrayed in the accounts of the early voyagers. The five succeeding chapters are devoted to a history of mound-building, and to a description of various groups of mounds with their attendant inclosures and fish-preserves. Among these ancient tumuli, antedating the period of European colonization, are mentioned and classified temple-mounds, terraced mounds, truncated pyramids, mounds of observation and retreat, chieftain-mounds, family or

tribal mounds, shell mounds, stone tumuli, and single graves. In this region there is a remarkable absence of megalithic monuments and animal-shaped mounds. The presence of rock-walls, embankments, and defensive inclosures, is noted; and, in connection with the grave-mounds, cremation and sundry funeral customs are alluded to and discussed. The plans of these prominent indications of early constructive skill are based upon original surveys, and the impressions conveyed of the monuments themselves are derived from the personal observations of the writer. The author does not concur in the opinion, so often expressed, that "the mound-builders were a race distinct from, and superior in art, government, and religion to, the Southern Indians of the fifteenth and sixteenth centuries." His reasons are fairly and cogently stated, and it is shown that the practice of sepulchral mound-building, and the construction of elevated spaces for chieftain-lodges and council-houses, were perpetuated within the historic period. In accounting for the marked decadence in industry, combined labor, craft and power which characterized these peoples in the eighteenth century, when their condition is contrasted with that of their ancestors, two centuries before, it is suggested that "the inroads of the Spaniards violently shocked this primitive population, imparting new ideas, interrupting established customs, overturning acknowledged government, impoverishing whole districts, engendering a sense of insecurity until that time unknown, causing marked changes, and entailing losses and demoralizations perhaps far more potent than we are inclined, at first thought, to believe."

Extended reference is made to the location and contents of refuse-piles and shell-heaps—objects which have of late attracted so much attention in many parts of the world, indicating, as they do, the resorts of primitive peoples, furnishing evidence of the food upon which they subsisted, and revealing the implements and utensils upon which they relied for daily use.

Stone-graves and the use of copper are treated of in the tenth chapter. Plate VI.—in which are figured the relics found in a stone-grave in Nacoochee Valley—possesses unusual beauty, and conveys an emphatic

idea of the commercial relations existing among the North American tribes. From this grave were taken a laminated copper axe, which had probably been obtained from the shores of Lake Superior, a *cassio flamma*, from the Gulf of Mexico or the Atlantic coast, the remnant of a basket made of a reed not native to the valley, and stone implements laboriously constructed of materials brought from a distance. All these were once the property of a single individual.

In the chapters upon arrow and spear heads—grooved, wedge-shaped, perforated, and ceremonial axes—cutting, piercing, smoothing, scraping, and agricultural implements—the author enters upon a well-considered analysis of the characteristics of the prevailing types, and accompanies his illustrations with descriptions and suggestions indicative of extensive research and accurate archæological knowledge.

In the fourteenth chapter we are made acquainted with the different methods adopted by the Southern Indians for the capture of fish. Grooved, notched, and perforated net-sinkers and plummets are figured. The *chung-kee game*—that famous game of the North American Indians, to which they were so passionately addicted that, when all private property had been gambled away, the desperate players hazarded even their personal liberty upon the final throw—is next considered; and, in this connection, numerous discoidal stones are shown. The limits of this review do not permit us to dwell upon the use of stone tubes in connection with the arts of the medicine-man and the conjurer, as explained by the author, or to enumerate *seriatim* the matters treated of in this entertaining and instructive volume. We commend, as worthy of careful study, the chapters upon pipes (which are considered under the three classes of idol-pipes, calumets, and common pipes), on idols and image-worship, and upon pottery. The Etowah idol, figured at page 432, is perhaps the most notable ancient stone image which has yet been found in association with Indian relics north and east of Mexico. Much historical information has been collected concerning the primitive uses of tobacco and the office of the peace-pipe. In plate XXIII the typical forms

of the calumets and bird-shaped pipes are given. The manufacture of ancient pottery is fully considered; and, in the accompanying plates, the prevailing forms of *terracotta* vessels, and the different styles of ornamentation, are beautifully portrayed. The use of pearls as ornaments is made the subject of an independent chapter. It is curious to observe what an important part these little glistening beads played among the ornament-loving peoples of this semi-tropical region. The work concludes with an examination of the primitive employment of shells as ornaments, implements, and as a recognized medium of exchange.

It will be observed that nearly every chapter in this work forms an independent essay, complete in itself, and elaborate of its kind. The originality of the work, both as regards its general plan and the manner of its execution, will be at once remarked. The freshness and vigor of the illustrations are admirable. The typical objects represented have never been figured before, the originals, or nearly all of them, forming part of the author's collection, and most of them having been obtained by him *in situ*. Accurate pen-drawings were first made under his personal supervision and then these were reproduced by the photo-lithographic process—all errors of transfer by an engraver being thus avoided. As a necessary consequence, these illustrations are unusually correct. They possess an individuality which is very attractive. In grouping the objects selected for illustration, marked taste has been displayed. The plan of the work we regard as natural and judicious. In that portion of North America constituting the field of these archæological researches we have only a stone age. Here and there copper implements and ornaments appear, but that material in its manufacture was regarded and treated by the primitive workmen not as a metal capable of being moulded under the influence of heat, but simply as a malleable stone. Chipped and ground stone implements are found in juxtaposition; and, in their uses, are seemingly of equal antiquity. Any attempt, therefore, in the present state of the inquiry, to pursue the classifications usually adopted by European archæologists appeared both unnecessary and improper. Realizing this fact, the

author has grouped and described the antiquities of the Southern Indians principally with respect to their uses. Monuments, implements, manufactures, and ornaments, are invested with such explanations as are suggested by the early narratives, by peculiar characteristics, by intelligent comparison, and by the special circumstances under which they were found. The classification adopted has been, in many instances, general, and the author has sought to avoid an error into which writers on kindred subjects are prone to fall, namely, a too rigid classification, and an attempt to refer each relic to some definite use. So uncertain is the boundary line which separates well-recognized types; so varied are the modifications of established forms; so great was the poverty of the manufacturers; and so various the purposes to which the same rude tool may have been applied in conducting early mechanical operations, that the candid observer may often confess himself at a loss to determine the positive object for which a given specimen may have been intended.

In his concluding observations the author says: "Upon a careful comparison of the antiquities of the Southern nations with those of the Northern tribes, we think a greater variety and excellence of manufacture, a more diversified expression of fancy in ornamentation, a more careful selection of beautiful material, a superior delicacy and finish in the fabrication of implements, both chipped and polished, a more pronounced exhibition of combined labor in the erection of tumuli, a more despotic form of government, a greater permanency of seats, a more liberal expenditure of care and attention in the cultivation of the soil, a more decided system of worship, and a more dignified observance of the significant festivals and funeral-customs, may fairly be claimed for the former. We are acquainted with no region north and east of the Rio Grande in which the earliest exhibitions of skill and taste in the manufacture of implements and ornaments of stone, shell, and bone, are more varied and attractive, where pipe-making claimed such special attention, and where the antique pottery is indicative of such diversity of form and ornamentation, and possessed of such homogeneity of composition and durability."

**WORKSHOP APPLIANCES;** including Descriptions of the Gauging and Measuring Instruments, the Hand Cutting-tools, Lathes, Drilling, Planing, and other Machine-tools used by Engineers. By C. P. B. SHELLEY, Civil Engineer. 209 Illustrations, 312 pages. Price, \$1.50. D. Appleton & Co.

THIS is a hand-book of tools and their uses, compendious in form, and copiously illustrated, which will be of great value to young artisans and mechanics, whether working in wood or metal. There is no end to machines for reshaping the materials of Nature, and inventors are constantly adding to them; but the fundamental tools for producing mechanical effects, with their resources of variation, fall into a few classes, and their modes of action are capable of explanation within a narrow space. It is the variation and recombination of comparatively a few implements that are constantly coming before us in the form of complex and obscurely-acting contrivances. Two objects are to be gained by the use of tools: 1. The production of given mechanical effects; and, 2. Accuracy in the processes. Both of these objects are now attained by mechanics with a remarkable degree of perfection. Mr. Shelley describes these in clear and simple language, which, with his excellent illustrations, makes the subject quite intelligible to ordinary readers. Besides its value as a practical hand-book to the working mechanic, this little volume will have great interest for those who wish to understand how the wonders of modern construction are executed.

---

## MISCELLANY.

**Yosemite Valley of Glacial Origin.**—In the summer of 1872, Prof. Joseph Le Conte, of the University of California, with several students of the institution, visited the Yosemite and the mountains contiguous, and carefully examined the results of the glacial action which were everywhere apparent. His conclusions were stated in an able paper, published in the *American Journal of Science* for May. The Yosemite Valley, he thinks, was once filled to the brim with a great glacier. In this he differs from Prof. Whitney, who in his guide-book ex-

presses the opinion that there is no evidence that such a glacier existed.

Prof. Le Conte observes that glaciated forms are unmistakably observable at many points on the walls of the valley, and in some places even to the brim. In the contour of the walls of the valley, their rounded form, where the rock is hard, standing unbroken and without *débris* at the base, he finds proofs of glacial erosion. On the north side of the valley, every projecting shoulder is thus rounded, and in some cases the smoothness is so complete, even at a considerable height, that the rocks glisten in the sunshine. Where the rocks are soft, and on the southern side of the valley, which is in shadow, frost and other agencies have done their work of disintegration. The surfaces are broken, and the *débris* lies at the base.

The bed-rock of the valley is covered with mounds of bowlders and sand, which are terminal moraines of glaciers, and by *stratified lake-deposits*, the lakes having been formed by the glacial mounds obstructing the flow of waters.

But it was from the higher elevations that the wonderful features of the glacial erosion were most distinctly observed. "From the edge of the rim of Little Yosemite," says the author, "we had a magnificent bird's-eye view of the wonderful dome-like form of nearly all the prominent points about this valley, and their striking resemblance to glaciated forms cannot be overlooked. The whole surface of the country is *moulonné* on a huge scale. If so, then the greater domes about the Yosemite have been formed in a similar manner. If so, then the whole surface of this region, with its greater and smaller domes, has been moulded beneath a universal ice-sheet, which moved on with steady current, careless of domes."

This great ice-sheet preceded the separate glaciers which completed the erosion of the valleys of which Yosemite is one, and the scattered snow-fields which were discovered by Mr. Muir, of the expedition, are feeble remains of the old glaciers. In the opinion of Prof. Whitney, the Yosemite was formed by a sudden engulfment of a portion of the sierras, but Prof. Le Conte observes that Yosemite is not unique in

form, and probably not in origin. There are many Yosemite. Many of the great glacial valleys become deep, narrow cañons, with precipitous walls near the junction of the granites with the slates. This is the position of Yosemite. It occurs in the valley of the American River and the valley of Hetch Hetchy, which, says the author, almost rivals the Yosemite in grandeur, and, in his opinion, all these deep, perpendicular slots have been sawed out by the action of glaciers, the verticality of the walls having been determined by the perpendicular cleavage of the rocks.

**Origin of the Potato-Disease.**—Messrs. T. & E. Brice, of Plymtree, England, claim to have discovered the cause of the potato and the foot and mouth diseases, which they assert to be nothing else but the employment of chemical manures. It is remarkable, say they, that both of these diseases made their appearance about the same period. It is some 250 years since the potato was introduced into Britain, and there is no record that the disease ever existed until the year 1845, when, subsequently to a continued rain for some days together, the potato was found to be diseased generally throughout the kingdom. Previous to that time the chemical manures had been introduced, and they were used in great abundance the same season that the potato-disease first appeared. Messrs. Brice were then of opinion that the manure was the cause, and, having since investigated its principles and action, they find that it contains a very active poison—sulphuric acid: “Its particles readily attract the particles of water, producing fermentation, and sometimes causing putrefaction of the compound they adhere to. If the chemical manures are distributed over the land in a dry season, and there is not enough rain to cause fermentation, the sulphuric acid remains fixed on the earth; if it is applied in a wet season, the rain causes fermentation; the effluvium ascends in the atmosphere, and, mixing with the vapors, helps to constitute clouds, when there is a return in poisoned rain and dew on the potatoes, and other bodies as well. Putrefaction of the potato is the consequence, and it has a very offensive smell.” The

authors have made some experiments with a mixture of water and sulphuric acid. Fermentation and poisoning of the water were the result, and an application of the mixture to the potato caused disease.

But the question naturally arises, Why should the sulphuric acid cause disease only in the potato and not in other plants? and on this point the Messrs. Brice leave us in the dark. Here we may mention another theory which has been proposed to account for this potato-blight. It has been observed that the electrical state of the atmosphere has something to do with the matter, and in Ireland the potato-crop is described as wearing a blighted appearance after a protracted thunder-storm. The theory is, that the electrical condition of the atmosphere causes the conversion of the starch into dextrine, sugar, etc., and the tuber then melts away. But again we ask, Why did not the same causes produce the same effects previous to 1845?

As regards the foot and mouth disease, the cattle and other animals travel and browse where the poison has fallen, and it is taken in with their food. The active particles adhere to their feet, lips, and mouth, destroying the scarf-skin and mucous membrane of the mouth and throat. The symptoms are such as might be produced by sulphuric and other corrosive acids.

**A Substitute for Parchment.**—Parchment-paper has several properties in common with animal membrane. It is obtained by the action of sulphuric acid or chloride-of-zinc solution on unsized paper. When sulphuric acid is employed, the best solution is one kilogramme (2.20485 pounds) English concentrated sulphuric acid to 125 grammes (about 4.4 ounces) of water. The paper is dipped into the acid so as to moisten both sides uniformly. The length of time it is to remain in the bath depends on its own thickness and density. The minimum time for the ordinary unsized paper of commerce is 5 seconds, the maximum 20. When the acid has acted a sufficient length of time, the paper is first dipped in cold water, then in dilute ammonia, again in water, to remove the acid, and finally it



is dried. When it is left to itself to dry, it becomes shriveled, and has a bad appearance. To guard against this, the following process is adopted: An endless strip of paper is passed by machinery first through a vat of sulphuric acid, and then through water, ammonia, and water again; next a cloth-covered roller deprives it of a portion of the water, and finally it is pressed and smoothed out by means of polished heated cylinders.

When properly manufactured, parchment-paper has the same color and translucency as animal parchment, its structure having undergone a change from fibrous to corneous. In point of cohesion and hygroscopicity, it is very much like common parchment. When dipped in water, it becomes soft and flaccid. It is impermeable to liquids, except by dialysis. These qualities render parchment-paper specially suitable for diplomas, important papers, and in general for documents which it is desirable to preserve. As compared with ordinary parchment, this paper possesses the advantage that it is very little liable to be attacked by insects. Then, too, the characters inscribed on it cannot be effaced without difficulty, and, when effaced, cannot be replaced by others—a perfect guarantee against all kinds of falsification. By reason of its firmness and durability, it is specially suited for plans and drawings, particularly architectural drawings, which are much exposed to moisture. Further, it might be used for covering books; or books, maps, etc., for use in schools, could be printed on it, and would be very durable. In place of animal membrane, it is well suited for covering jars of fruit, extracts, etc., as also for connecting the parts of distilling and other apparatus. It furnishes excellent casings for sausages. In surgery it is employed instead of linen, oiled cloth, and gutta-percha, for dressing wounds.

#### **Improvements in Street-Sprinkling.—**

An improved method of sprinkling streets has been patented in England, by means of which almost five-sixths of the expense of watering may be saved. It appears that the cost for labor in watering the streets of London averages about \$675,000 per annum, the cost of water being additional;

and it is contended that this work can be done in a far more effectual and advantageous manner, by a system of permanent pipes, for an expenditure of less than \$15,000 per annum, while the interest upon the plant necessary for the purpose would not exceed \$100,000. An experiment made in Hyde Park warrants the conclusion that, with the permanent system referred to, the services of one man would be amply sufficient for laying the dust over the whole of the drives and rides in that park—a task which at present engages twenty men, with as many horses and carts. This area may be taken as a seventy-fifth part of the total road-way in London to be watered; and hence we may conclude that about seventy-five men, without either horses or carts, could water the whole metropolis at the cost for labor above stated. The city government of London is giving the matter serious consideration; and, if water is to continue in use for the purpose of laying dust on thoroughfares, the plan will doubtless be generally adopted on being proved practicable. It is to be hoped, however, that before long deliquescent salts will be employed for this purpose rather than water. The use of water in summer hastens the decay of organic matter, and thus is objectionable from a sanitary point of view. Deliquescent salts will not alone lay the dust, but will also disinfect the streets by checking decomposition.

**French Association for the Advancement of Science.**—The French Association met at Lyons, on August 21st, the opening address being made by the president, Quatrefages. He traced the history of scientific progress during the past hundred years, and advocated the claims of science as an important branch of general education. The reports of the secretary and treasurer show that the Association is in a flourishing state, and that it has already, in its second year, commenced to give material encouragement to original investigators of science. The most notable of the papers read in the general meetings were the following: Dr. H. Blanc, Surgeon-Major of the British Army, on "The Means of guarding against Cholera: an Essay based on Practical Knowledge of the Causes and Mode of Propaga-



tion of that Disease ;" Fernand Papillon, on "The Relations between Science and Metaphysics ;" the Abbé Ducrost, on "The Prehistoric Station of Solutré ;" and Dr. Bertillon on "The Population of France."

One of the sections of the French Association is devoted to the medical sciences. In this department, the most remarkable papers were those of M. Ollier, on "The Surgical Means of favoring the Growth of the Bones in Man ;" M. Chauveau, on "The Transmission of Tuberculosis through the Digestive Organs ;" M. J. Gayet, on "The Regeneration of the Crystalline Lens ;" and M. Diday, on "A Physiological Theory of the Passion of Love."

In anthropology, we may mention M. Lagneau's "Ethnological Researches on the Basin of the Saone and Other Affluents of the Rhone ;" M. Chauvet's "Observations on the Bone-Caves of Charente," Gabriel Mortillet and Abel Hovelacque on "The Precursor of Man in the Tertiary Period."

The chemical section presents matter of special interest only for chemists. In that of botany, M. Merget read a paper on "The rôle of the Stomata in the Exchange of Gases between the Plant and the Atmosphere."

**The Cryptograph.**—A very ingenious instrument, the cryptograph, was recently described by its inventor, Pelegrin, in a note communicated to the French Academy of Sciences. The cryptograph is a contrivance intended for noting down on the spot and converting into mathematical expressions, so that they may be sent directly and secretly by telegraph, the polar coordinates of the points which determine a given figure. By means of this instrument, one may—at New York, for instance—trace out figures seen and noted down by a correspondent at any point in telegraphic communication with him. The cryptograph consists of a graduated arc of a circle, and an alidade, or index, also graduated and movable over the entire arc. The alidade has attached to it a small, thin plate of mica, which may slide up and down its entire length. On the mica is a black point, and this, it is plain, may occupy every possible position within the arc. A sight is fixed in front of the instrument. In order, now, to note down the outlines of a given

figure, the observer places his eye at the sight, and brings the black speck on the mica over all the chief points, and marks their polar coördinates, as shown by the positions of the alidade and the sliding-point. These numbers may then be transmitted by telegraph anywhere. With the assistance of another cryptograph, in which the mica is replaced by a style or pen, the points noted by the first instrument are at once found and copied on paper.

**Localization of the Faculty of Speech.**—In a recent memoir on the localization of the faculty of speech in the anterior lobes of the brain, the eminent physiologist Bouillaud communicates to the French Academy of Sciences the results of his protracted researches on that subject. Some of the cases cited by him in the course of the memoir are extremely curious. In some instances, says he, the inability to speak is restricted to a certain class of words—certain proper names, for instance ; in others, it extends to all past events ; in others, again, only prominent circumstances are involved ; and so on. Cuvier tells of a man who had lost the recollection of all *nouns-substantive*, and who would construct his phrases perfectly and regularly, the places of the nouns being always left vacant. Some years ago, M. Bouillaud visited a patient whose vocabulary did not contain a single *verb*, but who, notwithstanding, talked with remarkable volubility : his language was, of course, perfectly unintelligible. Others are unable, of their own accord, to write some particular word—*house*, for instance—though they can copy it when it is placed before them. A lady, forty-three years of age, was suddenly deprived of the power of speech, and entered the Cochin Hospital ; she heard and understood perfectly every thing that was said to her, but could not speak. She could express herself in writing, however, and thus it was learned that she suffered pain in the forehead. From these cases, it follows that aphasia is produced by an incapacity to execute the coördinate movements requisite for pronunciation, and that it has nothing to do with loss of memory as to the meaning of words.

According to M. Bouillaud, these phenomena are produced by lesions of the an-

terior cerebral lobes. He claims that his theory is confirmed by the results of several autopsies, and asserts that, wherever he has had an opportunity to examine the brain of patients affected in this way, he always found the anterior lobes softened, inflamed, and more or less profoundly disorganized. These views gave rise to a warm discussion when they were first published to the Academy, and Flourens contributed an important memoir on the subject, in which he took the ground that while the cerebral lobes possess the faculties of will and perception, they do not coördinate movements, the latter function appertaining, according to him, to the cerebellum.

M. Bouillaud sums up as follows the conclusions to which he has been led in the course of his studies: 1. All lesions of the faculty of speech have their origin in affections of the frontal lobes. In some instances, this lesion to the faculty of speech is owing to the fact that the coördinated movements requisite for the *pronunciation of words* cannot be executed. Therefore, there exists in these anterior lobes a coördinating centre for this description of voluntary movements. In other instances, lesions of the faculty of speech have a bearing on the *words* themselves, and not on the act of *pronouncing* them. Therefore, there exists in the same lobes another centre, without the coöperation of which speech is impossible.

2. When either or both of these conditions exist, the faculty of speech may be injured or utterly lost, while all the other special intellectual faculties remain intact, and *vice versa*.

**The Rebuilding of Antioch.**—In the rebuilding of the city of Antioch, destroyed by earthquake last year, the chief engineer of the province of Aleppo, Mr. Haddan, an Englishman, did his best to induce the people to profit by the experience of the past, and to construct their houses and lay out their streets in such a manner that the recurrence of earthquake might not again prove so destructive. But immobility is the law of the East, and the people will not quit the ancient paths. It is a significant fact, says the *Builder*, that many of the victims on the occasion of the last earthquake might have escaped, if the houses had been

built with lime or bound with wood, and if the streets had not been so narrow that the rows of falling buildings met as they crumbled down, to form one destructive heap over the crowds of people. Mr. Haddan proposed that skeleton houses should be erected with timber battens, well tied together with iron bands, on which overhanging roofs would rest. Stone-walls, cemented with lime, were then to be run up around the wooden frames, in order to afford protection from sun and rain. A shock of earthquake (which is a matter of frequent occurrence at Antioch), how formidable soever it might be, could then do no more than throw the stone-walls outward, while none of the falling stones could injure those in the houses. The new plan of the town, by straightening and widening the labyrinth of tortuous lanes which previously existed, would save the inhabitants from much of the danger after escaping from their houses. But, as has been already said, these suggestions have been disregarded, and the town is beginning to rise again on its old foundations, built with mud instead of lime, and likely to destroy its future population in even greater proportion than it did last year, for increased poverty makes the new houses weaker than even the old ones were.

**Intelligence of the Toad.**—At the recent meeting of the American Association for the Advancement of Science, held at Portland, Mr. Thomas Hill read a note on the intelligence of toads, giving, among other interesting examples of their sagacity, a description of the means by which the creature contrives to force down inconvenient forms of food. "When our toad," says Mr. Hill, "gets into his mouth part of an insect too large for his tongue to thrust down his throat (and I have known of their attempting a wounded humming-bird), he resorts to the nearest stone," and uses it as a *pièce de résistance* in a very literal sense. This can be observed at any time, continues the author, by tying a locust's hind-legs together, and throwing it before a small toad.

On one occasion Mr. Hill gave a small locust to a little toad in its second summer. At once the locust's head was down the creature's throat, the hinder parts protrud-

ing. The toad then sought for a stone or clod; but, as none was to be found, he lowered his head and crept along, pushing the locust against the ground. But the ground was too smooth (a rolled path) and the angle at which the locust lay to the ground too small, and thus no progress was made. "To increase the angle, he straightened up his hind-legs, but in vain. At length he threw up his hind-quarters, and actually stood on his head, or rather on the locust sticking out of his mouth, and, after repeating this once or twice, succeeded in getting himself outside his dinner."

On another occasion the author saw an American toad disposing of an earthworm in the following way. The worm was so long that it had to be swallowed by sections. But, while one end was in the toad's stomach, the other end was coiled about his head. "He waited until the worm's writhings gave him a chance, and swallowed half an inch; then, taking a nip with his jaws, waited for a chance to draw in another half-inch. But there were so many half-inches to dispose of that at length his jaws grew tired, lost their firmness of grip, and the worm crawled out five-eighths of an inch between each half-inch swallowing. The toad, perceiving this, brought his right hand to his jaws, grasping his abdomen with his foot, and, by a little effort getting hold of the worm in his stomach from the outside, he thus, by his foot, held fast to what he had gained by each swallow, and presently succeeded in getting the worm entirely down."

**The Sun's Envelope.**—Prof. Charles A. Young's paper, read at the American Association, on a liquid solar crust, led to a very animated discussion. The author is inclined to hold, with Faye, Secchi, and others, that the sun is mainly gaseous. At the same time, the eruptions which are continually occurring on its surface almost compel the supposition that there is a crust of some kind which retains the imprisoned gases, and through which they force their way in jets with great violence. According to the author, this crust may consist of a more or less continuous sheet of descending rain—that is, a downfall of the condensed vapors of those materials which we know from the

spectroscope exist in the sun. The continuous efflux of the solar heat is equivalent to the supply that would be developed by the condensation from steam to water of a layer of about five feet thick over the whole surface of the sun every minute of time. As this tremendous rain descends, the velocity of the falling drops would be retarded by the resistance of the denser gases underneath; the drops would coalesce until a continuous sheet would be formed; and these sheets would unite and form a sort of bottomless ocean resting on the compressed vapors beneath, and pierced by innumerable ascending jets and bubbles. It would have an approximately constant depth, because it would turn to vapor at the bottom as rapidly as it grew at the surface, though probably the thickness of this crust would continually increase at a slow rate, and its whole diameter grow less.

In other words, Dr. Young would regard the sun as an enormous bubble whose walls are steadily thickening, and its diameter ever lessening, in proportion to the loss of heat. The hypothesis offers no peculiar explanation of the sun-spots, but will agree with any of the current explanations of that phenomenon.

---

## NOTES.

PROF. STRONG, of the Drew Theological Seminary, Madison, N. J., is organizing an expedition to Egypt and the Holy Land. It will start about Christmas, and will embrace in its *personnel*, engineers, artists, scientists, and a select party of tourists, all under charge of Prof. Strong, assisted by Prof. T. Norman and Mr. George May Powell.

THE *Boston Medical and Surgical Journal* reports a case of semi-asphyxiation from the inhalation of coal-gas, which was very successfully treated by the administration of oxygen. Four men sleeping in one room had inhaled coal-gas. Of these one died before medical aid arrived; the other three were taken to the hospital. Here fresh air and stimulants were resorted to, but the most marked effects followed the administration of oxygen gas. The inhalation of this agent was followed by an almost instantaneous improvement in the condition of the patients. It was found that the supply of oxygen had to be kept up for some time after the appearance of improved respiration, for, when the administration

of the gas was discontinued, a relapse occurred. Soon, however, the improvement became permanent, and the patients were discharged well.

A WRITER in a French scientific periodical states that by feeding silk-worms on vine-leaves he has obtained cocoons of a magnificent red, and, by feeding them on lettuce, others of a very deep emerald green. Another silk-grower has obtained cocoons of a beautiful yellow, others of a fine green, and others again of violet, by feeding the silk-worms on lettuce, or on white nettle. He says that the silk-worms must be fed on mulberry-leaves when young, and supplied with the vine, lettuce, or nettle leaves, during the last twenty days of the larva stage of their life.

A LONDON *Times* correspondent bestows merited praise upon the ventilation of the opera-house at Vienna. On the occasion of the shah's visit, though the house was filled in every part, and though the temperature outside was no less than 85° after sunset, still in the overcrowded house the temperature was just agreeable. The thermometers in the house were under continual inspection, and the temperature regulated according to their indications. What facilitates this regulation is that the gas-lights are under glass globes, which are so arranged that the smoke and heat are carried out by the flue which is above every flame. This arrangement has, besides, the advantage that, even when the house is fully illuminated, the light is never glaring.

CARBOLIC-ACID paper is now much used for packing fresh meats for the purpose of preserving them against spoiling. The paper is prepared by melting five parts of stearine at a gentle heat, and then stirring in thoroughly two parts of carbolic acid, after which five parts of melted paraffine are added. The whole is to be well stirred together till it cools, after which it is melted and applied with a brush to the paper, in quires, in the same way as in preparing the waxed paper so much used in Europe for wrapping various articles.

FROM the official report of Captain G. A. Stover, British political agent at Mandalay, it would appear that Upper Burmah is richer in metals and minerals than any other country in the known world. Gold exists in profusion in the rivers and streams, and in many districts the gold quartz is found in abundance; but the localities are generally malarious, and the mines are not developed. Silver, too, is found in considerable quantities. Rich deposits of copper exist, but are unutilized. Iron abounds in the Shan states and the districts south of Mandalay. Lead is plentiful, and, though tin exists in the Shan states, the mines have never been

worked. Coal equal to the best English coal has been discovered in many parts of the interior.

A BERLIN correspondent of the London *Times* gives an account of the extraordinary performance of the new Prussian infantry arm, the Mauser gun. The writer says: "On a distance of 1,500 metres (1,640 yards), out of 480 shots, 399 hits were effected in five targets placed behind each other; and on 1,400 metres (1,564 yards), out of 480 shots, 460 hits are reported. To attack a line in a good position, defended by disciplined soldiers armed with the Mauser, would be the greatest blunder."

O. FEISTMANTEL, of the Austrian Geological Institute, lately read before that body an essay on "The Fossil Plants of Germany and Austria," which will attract the earnest attention of the students of paleontological botany. The author first visited and thoroughly studied all the chief collections of botanical fossils existing in the two countries, and then set about a revision of the species described. He shows that at present the science of phytopaleontology is in a state of confusion, the same species being often described under different names. Different portions of one plant too often figure under sundry names, being sometimes referred to widely diverse genera. Thus we find in some cases the fruit of a plant attributed to one species, while its leaf, trunk, etc., are attributed to others.

THE performance of the "Woolwich infants," or 35-ton English guns, will probably bring about a revolution in the art of naval construction. Experiment has shown that, with the service-charge of powder and the 700-pound shot, these enormous engines can send the projectile through 15 inches of iron at 200 yards, through 14 inches at 300 yards, through 12 inches at 1,700 yards, through 11 inches at 2,600 yards, through 9 inches at 4,000 yards, through 8 inches at 4,500 yards. In each case the usual backing of hard wood has to be added to the thickness of the iron target. Thus, at a range of nearly three miles, a shell one-third of a ton in weight can be made to pierce the sides of some of the heaviest iron-clads, which, a few years ago, were thought to be well protected by 8 or 9 inches of iron.

HIS excellency Chérif Pasha, Minister of Foreign Affairs, has made an order, in behalf of his government, on R. Habersham, Son & Co., Savannah, Georgia, through R. Beardsley, Esq., consul-general of the United States at Alexandria, Egypt, for fifteen tons of Sea-Island cotton-seed for culture in Egypt, under the express direction of the ruler of that country, Ismail Pasha.

1875  
1875  
1875

1875  
1875



DR. JOSEPH DALTON HOOKER.



THE  
POPULAR SCIENCE  
MONTHLY.

---

DECEMBER, 1873.

---

RADICALISM, CONSERVATISM, AND THE TRANSI-  
TION OF INSTITUTIONS.<sup>1</sup>

BY HERBERT SPENCER.

OF readers who have accompanied me thus far, probably some think that the contents of these papers go beyond the limits implied by their title. Under the head *Study of Sociology*, so many sociological questions have been incidentally discussed, that the science itself has been in a measure dealt with while dealing with the study of it. Admitting this criticism, my excuse must be that the fault, if it is one, has been scarcely avoidable. Nothing to much purpose can be said about the study of any science without saying a good deal about the general and special truths it includes, or what the expositor holds to be truths. To write an essay on the study of astronomy, in which there should be no direct or implied conviction respecting the Copernican theory of the solar system, nor any such recognition of the law of gravitation as involved acceptance or rejection of it, would be a task difficult to execute, and, when executed, probably of little value. Similarly with Sociology—it is next to impossible for the writer who points out the way toward its truths to exclude all tacit or avowed expressions of opinion about those truths, and, were it possible to exclude such expressions of opinion, it would be at the cost of those illustrations needed to make his exposition effective.

Such must be, in part, my defense for having set down many thoughts which the title of this work does not cover. Especially have I found myself obliged thus to transgress, by representing the study of sociology as the study of evolution in its most complex form. It is clear that, to one who considers the facts societies exhibit as having had their origin in supernatural interpositions, or in the wills of individual ruling men, the study of these facts will have an aspect wholly unlike that which it has to one who contemplates them as gen-

<sup>1</sup> Concluding article of the series on the "Study of Sociology."

erated by processes of growth and development continuing through centuries. Ignoring, as the first view tacitly does, that conformity to law, in the scientific sense of the word, which the second view tacitly asserts, there can be but little community between the methods of inquiry proper to them respectively. Continuous causation, which in the one case there is little or no tendency to trace, becomes, in the other case, the chief object of attention; whence it follows that there must be formed wholly different ideas of the appropriate modes of investigation. A foregone conclusion respecting the nature of social phenomena is thus inevitably implied in any suggestions for the study of them.

While, however, it must be admitted that throughout these articles there runs the assumption that the facts, simultaneous and successive, which societies present, have a genesis no less natural than the genesis of facts of all other classes, it is not admitted that this assumption was made unawares, or without warrant. At the outset, the grounds for it were examined. The notion, widely accepted in name, though not consistently acted upon, that social phenomena differ from phenomena of most other kinds, as being under special providence, we found to be entirely discredited by its expositors; nor, when closely looked into, did the great-man-theory of social affairs prove to be more tenable. Besides finding that both these views, rooted as they are in the ways of thinking natural to primitive men, would not bear criticism, we found that even their defenders continually betrayed their beliefs in the production of social changes by natural causes—tacitly admitted that after certain antecedents certain consequents are to be expected—tacitly admitted, therefore, that some prevision is possible, and therefore some subject-matter for science.

From these negative justifications for the belief that sociology is a science, we turned to the positive justifications. We found that every aggregate of units, of any order, has certain traits necessarily determined by the properties of its units. Hence it was inferable, *a priori*, that, given the natures of the men who are their units, and certain characters in the societies formed are predetermined—other characters being determined by the coöperation of surrounding conditions. The current assertion, that sociology is not possible, implies a misconception of its nature. Using the analogy supplied by a human life, we saw that just as bodily development, and structure, and function, furnish subject-matter for biological science, though the events set forth by the biographer go beyond its range, so, social growth, and the rise of structures and functions accompanying it, furnish subject-matter for a science of society, though the facts with which historians fill their pages mostly yield no material for science. Thus conceiving the scope of the science, we saw, on comparing rudimentary societies with one another, and with societies in different stages of progress, that they *do* present certain common traits of structure and of function, as well

as certain common traits of development. Further comparisons, similarly made, opened large questions, such as that of the relation between social growth and organization, which form parts of this same science—questions of transcendent importance, compared with those occupying the minds of politicians and writers of history.

The difficulties of the Social Science next drew our attention. We saw that in this case, though in no other case, the facts to be observed and generalized by the student are exhibited by an aggregate of which he forms a part. In his capacity of inquirer, he should have no inclination toward one or other conclusion respecting the phenomena to be generalized; but, in his capacity of citizen, helped to live by the life of his society, embedded in its structures, sharing in its activities, breathing its atmosphere of thought and sentiment, he is partially coerced into such views as favor harmonious coöperation with his fellow-citizens. Hence immense obstacles to the social science, unparalleled by those standing in the way of any other science.

From considering thus generally these causes of error, we turned to consider them specially. Under the head of Objective Difficulties, we glanced at those many ways in which evidence collected by the sociological inquirer is vitiated. That extreme untrustworthiness of witnesses which results from carelessness, or fanaticism, or self-interest, was illustrated; and we saw that, in addition to the perversions of statement hence arising, there are others which arise from the tendency there is for some kinds of evidence to draw attention, while evidence of opposite kinds, much larger in quantity, draws no attention. Further, it was shown that the nature of sociological facts, each of which is not observable in a single object or act, but is reached only through registration and comparison of many objects and acts, makes the perception of them harder than that of other facts. It was pointed out that the wide distribution of social phenomena in space greatly hinders true apprehensions of them; and it was also pointed out that another impediment, even still greater, is consequent on their distribution in time—a distribution such that many of the facts to be dealt with take centuries to unfold, and can be grasped only by combining in thought multitudinous changes that are slow, involved, and not easy to trace.

Beyond these difficulties which we grouped as distinguishing the science itself, objectively considered, we saw that there are other difficulties, conveniently to be grouped as subjective, which are also great. For the interpretation of human conduct as socially displayed, every one is compelled to use, as a key, his own nature—ascribing to others thoughts and feelings like his own; and yet, while this automorphic interpretation is indispensable, it is necessarily more or less misleading. Very generally, too, a subjective difficulty arises from the lack of intellectual faculty complex enough to grasp these social phenom-

ena, which are so extremely involved. And, again, very few have by culture gained that plasticity of faculty requisite for conceiving and accepting those immensely-varied actualities which societies in different times and places display, and those multitudinous possibilities to be inferred from them.

Nor, of subjective difficulties, did these exhaust the list. From the emotional as well as from the intellectual part of the nature, we saw that there arise obstacles. The ways in which beliefs about social affairs are perverted, by intense fears and excited hopes, were pointed out. We noted the feeling of impatience, as another common cause of misjudgment. A contrast was drawn showing, too, what perverse estimates of public events men are led to make by their sympathies and antipathies—how, where their hate has been aroused, they utter unqualified condemnations of ill-deeds for which there was much excuse, while, if their admiration is excited by vast successes, they condone inexcusable ill-deeds immeasurably greater in amount. And we also saw that, among the distortions of judgment caused by the emotions, have to be included those immense ones generated by the sentiment of loyalty to a personal ruler, or to a ruling power otherwise embodied.

These distortions of judgment caused by the emotions, thus indicated generally, we went on to consider specially—treating of them as different forms of bias. Though, during education, understood in a wide sense, many kinds of bias are commenced or given, there is one which our educational system makes especially strong—the double bias in favor of the religions of enmity and of amity. Needful as we found both of these to be, we perceived that among the beliefs about social affairs, prompted now by the one and now by the other, there are glaring incongruities; and that scientific conceptions can be formed only when there is a compromise between the dictates of pure egoism and the dictates of pure altruism, for which they respectively stand.

We observed, next, the warping of opinion which the bias of patriotism causes. Recognizing the truth that the preservation of a society is made possible only by a due amount of patriotic feeling in citizens, we saw that this feeling inevitably disturbs the judgment when comparisons between societies are made, and that the data required for Social Science are thus vitiated; and we saw that the effort to escape this bias, leading as it does to an opposite bias, is apt to vitiate the data in another way. While finding the class-bias to be no less essential, we found that it no less inevitably causes one-sidedness in the conceptions of social affairs. Noting how the various sub-classes have their specialties of prejudice corresponding to their class-interests, we noted, at greater length, how the more general prejudices of the larger and more widely-distinguished classes prevent them from forming balanced judgments. That in politics the bias of party interferes with those calm examinations by which alone the conclusions of Social Science can be reached, scarcely needed pointing out. We observed,

however, that, beyond the political bias under its party-form, there is a more general political bias—the bias toward an exclusively-political view of social affairs, and a corresponding faith in political instrumentalities. As affecting the study of Social Science, this bias was shown to be detrimental as directing the attention too much to the phenomena of social regulation, and excluding from thought the activities regulated, constituting an aggregate of phenomena far more important.

Lastly, we came to the theological bias, which, under its general form and under its special forms, disturbs in various ways our judgments on social questions. Obedience to a supposed divine command being its standard of rectitude, it does not ask concerning any social arrangement whether it conduces to social welfare, so much as whether it conforms to the creed locally established. Hence, in each place and time, those conceptions about public affairs which the theological bias fosters, tend to diverge from the truth in so far as the creed then and there accepted diverges from the truth. And besides the positive evil thus produced, there is a negative evil, due to discouragement of the habit of estimating actions by the results they eventually cause—a habit which the study of Social Science demands.

Having thus contemplated in general and in detail the difficulties of the Social Science, we turned our attention to the preliminary discipline required. Of the conclusions reached so recently, the reader scarcely needs reminding. Study of the sciences in general having been pointed out as the proper means of generating fit habits of thought, it was shown that the sciences especially to be attended to are those treating of Life and of Mind. There can be no understanding of social actions without some knowledge of human nature; there can be no deep knowledge of human nature without some knowledge of the laws of Mind; there can be no adequate knowledge of the laws of Mind without knowledge of the laws of Life. And, that knowledge of the laws of Life, as exhibited in Man, may be properly grasped, attention must be given to the laws of Life in general.

What is to be hoped from such a presentation of difficulties and such a programme of preparatory studies? Who, in drawing his conclusions about public policies, will be made to hesitate by remembering the many obstacles that stand in the way of right judgments? Who will think it needful to fit himself by inquiries so various and so extensive? Who, in short, will be led to doubt any of the inferences he has drawn, or be induced to pause before he draws others, by consciousness of these many liabilities to error arising from want of knowledge, want of discipline, and want of duly-balanced sentiments?

To these questions there can be but the obvious reply—a reply which the foregoing chapters themselves involve—that very little is to be expected. The implication throughout the argument has been that for every society, and for each stage in its evolution, there is an appro-

appropriate mode of feeling and thinking; and that no mode of feeling and thinking not adapted to its degree of evolution, and to its surroundings, can be permanently established. Though not exactly, still approximately, the average opinion in any age and country is a function of the social structure in that age and country. There may be, as we see during times of revolution, a considerable incongruity between the ideas that become current and the social arrangements which exist, and are, in great measure, appropriate; though even then the incongruity does but mark the need for a readjustment of institutions to character. While, however, those successive compromises, which, during social evolution, have to be made between the changed natures of citizens and the institutions evolved by ancestral citizens, imply disagreements, yet these are but partial and temporary—in those societies, at least, which are developing and not in course of dissolution. For a society to hold together, the institutions that are needed and the conceptions that are generally current must be in tolerable harmony. Hence, it is not to be expected that modes of thinking on social affairs are to be in any considerable degree changed by whatever may be said respecting the Social Science, its difficulties, and the required preparations for studying it.

The only reasonable hope is, that here and there one may be led, in calmer moments, to remember how largely his beliefs about public matters have been made for him by circumstances, and how probable it is that they are either untrue or but partially true. When he reflects on the doubtfulness of the evidence which he generalizes, collected hap-hazard from a narrow area—when he counts up the perverting sentiments fostered in him by education, country, class, party, creed—when, observing those around, he sees that, from other evidence selected to gratify sentiments partially unlike his own, there result unlike views—he may occasionally recollect how largely mere accidents have determined his convictions. Recollecting this, he may be induced to hold these convictions not quite so strongly; may see the need for criticism of them with a view to revision; and, above all, may be somewhat less eager to act in pursuance of them.

While the few to whom a Social Science is conceivable may, to some degree, be thus influenced by what is said concerning the study of it, there can, of course, be no effect on the many to whom such a science seems an absurdity, or an impiety, or both. The feeling ordinarily excited, by the proposal to deal scientifically with these most complex phenomena, is like that which was excited in ancient times by the proposal to deal scientifically with phenomena of simpler kinds. As Mr. Grote writes of Socrates:

“Physics and astronomy, in his opinion, belonged to the divine class of phenomena, in which human research was insane, fruitless, and impious.”<sup>1</sup>

<sup>1</sup> “History of Greece,” vol. i., p. 498.



And as he elsewhere writes respecting the attitude of the Greek mind in general :

“ In his ” (the early Greek’s) “ view, the description of the sun, as given in a modern astronomical treatise, would have appeared not merely absurd, but repulsive and impious: even in later times, when the positive spirit of inquiry had made considerable progress, Anaxagoras and other astronomers incurred the charge of blasphemy for dispersonifying Hêlios, and trying to assign invariable laws to the solar phenomena.”<sup>1</sup>

That a likeness exists between the feeling then displayed respecting phenomena of inorganic Nature and the feeling now displayed respecting phenomena of Life and Society, is manifest. The ascription of social actions and political events entirely to natural causes, thus leaving out Providence as a factor, seems, to the religious mind of our day, as seemed to the mind of the pious Greek the dispersonification of Hêlios and the interpretation of the celestial motions otherwise than by immediate divine agency. As was said by Mr. Gladstone, in a speech made shortly after the publication of the second chapter of this volume :

“ I lately read a discussion on the manner in which the raising up of particular individuals occasionally occurs in great crises of human history, as if some sacred, invisible power had raised them up and placed them in particular positions for special purposes. The writer says that they are not uniform, but admits that they are common—so common and so remarkable that men would be liable to term them providential in a pre-scientific age. And this was said without the smallest notion apparently in the writer’s mind that he was giving utterance to any thing that could startle or alarm—it was said as a kind of commonplace. It would seem that in his view there was a time when mankind, lost in ignorance, might, without forfeiting entirely their title to the name of rational creatures, believe in a Providence, but that since that period another and greater power has arisen under the name of science, and this power has gone to war with Providence, and Providence is driven from the field—and we have now the happiness of living in the scientific age, when Providence is no longer to be treated as otherwise than an idle dream.”<sup>2</sup>

Of the mental attitude, very general beyond the limits of the scientific world, which these utterances of Mr. Gladstone exemplify, he has since given further illustration; and, in his anxiety to check a movement he thinks mischievous, has so conspicuously made himself the exponent of the anti-scientific view, that we may fitly regard his thoughts on the matter as typical. In an address delivered by him at the Liverpool College, and since republished with additions, he says :

“ Upon the ground of what is termed evolution, God is relieved of the labor of creation; in the name of unchangeable laws, He is discharged from governing the world.”

This passage proves the kinship between Mr. Gladstone’s conception of things and that entertained by the Greeks to be even closer than

<sup>1</sup> “History of Greece,” vol. i., p. 466.

<sup>2</sup> *Morning Post*, May 15, 1872.

above alleged; for its implication is, not simply that the scientific interpretation of vital and social phenomena as conforming to fixed laws is repugnant to him, but that the like interpretation of inorganic phenomena is repugnant. In common with the ancient Greek, he regards as irreligious any explanation of Nature which dispenses with immediate divine superintendence. He appears to overlook the fact that the doctrine of gravitation, with the entire science of physical astronomy, is open to the same charge as this which he makes against the doctrine of evolution; and he seems not to have remembered that throughout the past each further step made by Science has been denounced for reasons like those which he assigns.<sup>1</sup>

It is instructive to observe, however, that, in these prevailing conceptions expressed by Mr. Gladstone, which we have here to note as excluding the conception of a Social Science, there is to be traced a healthful process of compromise between old and new. For, as, in the current conceptions about the order of events in the lives of persons, there is a partnership, wholly illogical though temporarily convenient, between the ideas of natural causation and of providential interference, so, in the current political conceptions, the belief in divine interpositions goes along with, and by no means excludes, the belief in a natural production of effects on society by natural agencies set to work. In relation to the occurrences of individual life, we displayed our national aptitude for thus entertaining mutually-destructive ideas, when an unpopular prince suddenly gained popularity by outliving certain abnormal changes in his blood, and when, on the occasion of his recovery, providential aid and natural causation were unitedly recognized by a thanksgiving to God and a baronetcy to the doctor. And, similarly, we see that, throughout all our public actions, the theory which Mr. Gladstone represents, that great men are providentially raised up to do things God has decided upon, and that the course of affairs is supernaturally ordered thus or thus, does not in the least interfere with the passings of measures calculated to achieve desired ends in ways classed as natural, and nowise modifies the discussion of such measures on their merits, as estimated in terms of cause and consequence. While the prayers with which each legislative sit-

<sup>1</sup> In the appendix to his republished address, Mr. Gladstone, in illustration of the views he condemns, refers to that part of "First Principles" which, treating of the reconciliation of Science and Religion, contends that this consists in a united recognition of an Ultimate Cause which, though ever present to consciousness, transcends knowledge. Commenting on this view, he says: "Still it vividly recalls to mind an old story of the man who, wishing to be rid of one who was in his house, said: 'Sir, there are two sides to my house, and we will divide them; you shall take the outside.'" This seems to me by no means a happily-chosen simile, since it admits of an interpretation exactly opposite to the one Mr. Gladstone intends. The doctrine he combats is that Science, unable to go beyond the outsides of things, is forever debarred from reaching, and even from conceiving, the power within them; and, this being so, the relative positions of Religion and Science may be well represented by inverting the application of his figure.

ting commences show a nominal belief in an immediate divine guidance, the votes with which the sitting ends, given in pursuance of reasons which the speeches assign, show us a real belief that the effects will be determined by the agencies set to work.

Still it is clear that the old conception, while it qualifies the new but little in the regulating of actions, qualifies it very much in the formation of theories. There can be no complete acceptance of Sociology as a science so long as the belief in a social order not conforming to natural law survives. Hence, as already said, considerations touching the study of Sociology, not very influential even over the few who recognize a Social Science, can have scarcely any effects on the great mass to whom a Social Science is an incredibility.

I do not mean that this prevailing imperviousness to scientific conceptions of social phenomena is to be regretted. As implied in a foregoing paragraph, it is part of the required adjustment between existing opinions and the forms of social life at present requisite. With a given phase of human character there must, to maintain equilibrium, go an adapted class of institutions, and a set of thoughts and sentiments in tolerable harmony with those institutions. Hence, it is not to be wished that, with the average human nature we now have, there should be a wide acceptance of views natural only to a more highly-developed social state, and to the improved type of citizen accompanying such a state. The desirable thing is, that a growth of ideas and feelings tending to produce modification shall be joined with a continuance of ideas and feelings tending to preserve stability. And it is one of our satisfactory social traits, exhibited in a degree never before paralleled, that along with a mental progress which brings about considerable changes, there is a devotion of thought and energy to the maintenance of existing arrangements, and creeds, and sentiments—an energy sufficient even to reinvigorate some of the old forms and beliefs that were decaying. When, therefore, a distinguished statesman, anxious for human welfare as he ever shows himself to be, and holding that the defense of established beliefs must not be left exclusively to its “standing army” of “priests and ministers of religion,” undertakes to combat opinions at variance with a creed he thinks essential, the occurrence may be taken as adding another to the many signs of a healthful condition of society. That, in our day, one in Mr. Gladstone’s position should think as he does, seems to me very desirable. That we should have for our working-king one in whom a purely-scientific conception of things had become dominant, and who was thus out of harmony with our present social state, would probably be detrimental, and might be disastrous.

For it cannot be too emphatically asserted that this policy of compromise, alike in institutions, in actions, and in beliefs, which especially characterizes English life, is a policy essential to a society going

through the transitions caused by continued growth and development. The illogicalities and the absurdities to be found so abundantly in current opinions and existing arrangements are those which inevitably arise in the course of perpetual readjustments to circumstances perpetually changing. Ideas and institutions proper to a past social state, but incongruous with the new social state that has grown out of it, surviving into this new social state they have made possible, and disappearing only as this new social state establishes its own ideas and institutions, are necessarily, during their survival, in conflict with these new ideas and institutions—necessarily furnish elements of contradiction in men's thoughts and deeds. And yet, as, for the carrying on of social life, the old must continue so long as the new is not ready, this perpetual compromise is an indispensable accompaniment of a normal development. Its essentialness we may see on remembering that it equally holds throughout the evolution of an individual organism. The structural and functional arrangements during growth are never quite right: always the old adjustment for a smaller size is made wrong by the larger size it has been instrumental in producing—always the transition-structure is a compromise between the requirements of past and future, fulfilling in an imperfect way the requirements of the present. And this, which is shown clearly enough where there is simple growth, is shown still more clearly where there are metamorphoses. A creature which leads at two periods of its existence two different kinds of life, and which, in adaptation to its second period, has to develop structures that were not fitted for its first, passes through a stage during which it possesses both partially—during which the old dwindles while the new grows: as happens, for instance, in creatures that continue to breathe water by external branchiæ during the time they are developing the lungs that enable them to breathe air. And thus it is with the changes produced by growth in societies, as well as with those metamorphoses accompanying change in the mode of life—especially those accompanying change from the predatory to the industrial life. Here, too, there must be transitional stages during which incongruous organizations coexist: the first remaining indispensable until the second has grown up to its work. Just as injurious as it would be to an amphibian to cut off its branchiæ before its lungs were well developed, so injurious must it be to a society to destroy its old institutions before the new have become well-organized enough to take their places.

Non-recognition of this truth characterizes too much the reformers, political, religious, and social, of our own time; as it has characterized those of past times. On the part of men eager to rectify wrongs and expel errors, there is still, as there ever has been, so absorbing a consciousness of the evils caused by old forms and old ideas, as to permit no consciousness of the benefits these old forms and old ideas have yielded. This partiality of view is, in a sense, necessary. There must

be division of labor here as elsewhere: some who have the function of attacking, and who, that they may attack effectually, must feel strongly the viciousness of that which they attack; some who have the function of defending, and who, that they may be good defenders, must over-value the things they defend. But while this one-sidedness has to be tolerated, as in great measure unavoidable, it is in some respects to be regretted. Though, with grievances less serious and animosities less intense than those which existed here in the past, and which exist still abroad, there go mitigated tendencies to a rash destructiveness on the one side, and an unreasoning bigotry on the other, yet even in our country and age there are dangers from the want of a due both-sidedness. In the speeches and writings of those who advocate various political and social changes, there is so continuous a presentation of injustices, and abuses, and mischiefs, and corruptions, as to leave the impression that, for securing a wholesome state of things, there needs nothing but to set aside present arrangements. The implication seems ever to be that all who occupy places of power, and form the regulative organization, are alone to blame for whatever is not as it should be, and that the classes regulated are blameless. "See the injuries which these institutions inflict on you," says the energetic reformer. "Consider how selfish must be the men who maintain them to their own advantage and your detriment," he adds; and then he leaves to be drawn the manifest inference that, were these selfish men got rid of, all would be well. Neither he nor his audience recognizes the facts that regulative arrangements are essential; that the arrangements in question, along with their many vices, have some virtues; that such vices as they have do not result from an egoism peculiar to those who uphold and work them, but result from a general egoism—an egoism no less decided in those who complain than in those complained of. Inequitable government can be upheld only by the aid of a people correspondingly inequitable, in its sentiments and acts. Injustice cannot reign, if the community does not furnish a due supply of unjust agents. No tyrant can tyrannize over a people save on condition that the people is bad enough to supply him with soldiers who will fight for his tyranny and keep their brethren in slavery. Class-supremacy cannot be maintained by the corrupt buying of votes, unless there are multitudes of voters venal enough to sell their votes. It is thus everywhere and in all degrees—misconduct among those in power is the correlative of misconduct among those over whom they exercise power.

And, while, in the men who urge on changes, there is an unconsciousness that the evils they denounce are rooted in the nature common to themselves and other men, there is also an unconsciousness that amid the things they would throw away there is much worth preserving. This holds of beliefs more especially. Along with the destructive tendency there goes but little constructive tendency. The

criticisms made, imply that it is requisite only to dissipate errors, and that it is needless to insist on truths. It is forgotten that, along with forms which are bad, there is a large amount of substance which is good. And those to whom there are addressed condemnations of the forms, unaccompanied by the caution that there is a substance to be preserved in higher forms, are left, not only without any coherent system of guiding beliefs, but without any consciousness that one is requisite.

Hence the need, above admitted, for an active defense of that which exists, carried on by men convinced of its entire worth; so that those who attack may not destroy the good along with the bad.

And here let me point out, specifically, the truth already implied, that studying Sociology scientifically leads to fairer appreciations of different parties, political, religious, and other. The conception initiated and developed by Social Science is at the same time radical and conservative—radical to a degree beyond any thing which current radicalism conceives; conservative to a degree beyond any thing conceived by present conservatism. When there has been adequately seized the truth that societies are products of evolution, assuming, in their various times and places, their various modifications of structure and function, there follows the conviction that what, relatively to our thoughts and sentiments, were arrangements of extreme badness, had fitnesses to conditions which made better arrangements impracticable: whence comes a tolerant interpretation of past tyrannies at which even the bitterest Tory of our own days would be indignant. On the other hand, after observing how the processes that have brought things to their present stage are still going on, not with a decreasing rapidity indicating approach to cessation, but with an increasing rapidity that implies long continuance and immense transformations, there follows the conviction that the remote future has in store forms of social life higher than any we have imagined: there comes a faith transcending that of the radical, whose aim is some reorganization admitting of comparison to organizations which exist. And while this conception of societies as naturally evolved, beginning with small and simple types which have their short existences and disappear, advancing to higher types that are larger, more complex, and longer-lived, coming to still higher types like our own, great in size, complexity, and duration, and promising types transcending these in times after existing societies have died away—while this conception of societies implies that in the slow course of things changes almost immeasurable in amount are possible, it also implies that but small amounts of such changes are possible within short periods.

Thus, the theory of progress disclosed by the study of Sociology as science is one which greatly moderates the hopes and the fears of extreme parties. After clearly seeing that the structures and actions throughout a society are determined by the properties of its



units, and that (external disturbances apart) the society cannot be substantially and permanently changed, it becomes easy to see that great alterations cannot suddenly be made to much purpose. And when both the party of progress and the party of resistance perceive that the institutions which at any time exist are more deeply rooted than they supposed—when the one party perceives that these institutions, imperfect as they are, have a temporary fitness, while the other party perceives that the maintenance of them, in so far as it is desirable, is in great measure guaranteed by the human nature they have grown out of—there must come a diminishing violence of attack on one side, and a diminishing perversity of defense on the other. Evidently, so far as a doctrine can influence general conduct (which it can do, however, in but a comparatively small degree), the doctrine of evolution, in its social applications, is calculated to produce a *steady-ing* effect, alike on thought and action.

If, as seems likely, some should propose to draw the seemingly awkward corollary that, it matters not what we believe or what we teach, since the process of social evolution will take its own course in spite of us, I reply that, while this corollary is in one sense true, it is in another sense untrue. Doubtless, from all that has been said, it follows that, supposing surrounding conditions continue the same, the evolution of a society cannot be in any essential way diverted from its general course; though it also follows (and here the corollary is at fault) that the thoughts and actions of individuals, being natural factors that arise in the course of the evolution itself, and aid in further advancing it, cannot be dispensed with, but must be severally valued as increments of the aggregate force producing change. But, while the corollary is even here partially misleading, it is, in another direction, far more seriously misleading. For, though the process of social evolution is, in its general character, so far predetermined that its successive stages cannot be antedated, and that hence no teaching or policy can advance it beyond a certain normal rate, which is limited by the rate of organic modification in human beings, yet it is quite possible to perturb, to retard, or to disorder the process. The analogy of individual development again serves us. The unfolding of an organism, after its special type, has its approximately uniform course, taking its tolerably definite time; and no treatment that may be devised will fundamentally change or greatly accelerate these: the best that can be done is to maintain the required favorable conditions. But it is quite easy to adopt a treatment which shall dwarf, or deform, or otherwise injure: the processes of growth and development may be, and very often are, hindered or deranged, though they cannot be artificially bettered. Similarly with the social organism. Though by maintaining favorable conditions there cannot be more good done than that of letting social progress go on unhindered, yet an immensity of mischief may be done in the way of disturbing and distorting and re-

pressing, by policies carried out in pursuance of erroneous conceptions. And thus, notwithstanding first appearances to the contrary, there is a very important part to be played by a true theory of social phenomena.

A few words to those who think these general conclusions discouraging, may be added. Probably the more enthusiastic, hopeful of great ameliorations in the state of mankind, to be brought about rapidly by propagating this belief or initiating that reform, will feel that a doctrine negating their sanguine anticipations takes away much of the stimulus to exertion. If large advances in human welfare can come only in the slow process of things, which will inevitably bring them, why should we trouble ourselves?

Doubtless it is true that, on visionary hopes, rational criticisms have a depressing influence. It is better to recognize the truth, however. As, between infancy and maturity, there is no short cut by which there may be avoided the tedious process of growth and development through insensible increments, so there is no way from the lower forms of social life to the higher, but one passing through small successive modifications. If we contemplate the order of Nature, we see that everywhere vast results are brought about by accumulations of minute actions. The surface of the earth has been sculptured by forces which in the course of a year produce alterations scarcely anywhere visible. Its multitudes of different organic forms have arisen by processes so slow, that, during the periods our observations extend over, the results are in most cases inappreciable. We must be content to recognize these truths and conform our hopes to them. Light falling upon a crystal is capable of altering its molecular arrangements, but it can do this only by a repetition of impulses almost innumerable: before a unit of ponderable matter can have its rhythmical movements so increased by successive ethereal waves as to be detached from its combination and in another way arranged, millions of such ethereal waves must successively make infinitesimal additions to its motion. Similarly, before there arise, in human nature and human institutions, changes having that permanence which makes them an acquired inheritance for the human race, there must go innumerable recurrences of the thoughts, and feelings, and actions, conducive to such changes. The process cannot be abridged, and must be gone through with due patience.

Thus, admitting that for the fanatic some wild anticipation is needful as a stimulus, and recognizing the usefulness of his delusion as adapted to his particular nature and his particular function, yet the man of higher type must be content with greatly-moderated expectations, while he perseveres with undiminished efforts. He has to see how comparatively little can be done, and yet to find it worth while to do that little: so uniting philanthropic energy with philosophic calm.

## FURS AND THEIR WEARERS.

By JAMES H. PARTRIDGE.

THE skins used for fancy furs and robes are mostly obtained from the carnivorous or flesh-eating animals; as the sable, marten, mink, ermine, seal, otter, bear, etc.: some are obtained from the rodents or gnawers; as the beaver, coypou, or nutria, muskrat, rabbit, etc.: and a few are obtained from the ruminants, or those that chew the cud; as the bison, that supplies our buffalo-robes; and the paseng or wild-goat of Persia and the Caucasus, and the Assyrian or Siberian sheep, from whose young kids and lambs we obtain the much-used Astrakhan. We give illustrations of the principal fur-bearing animals, several of which are taken from Tenney's excellent "Manual of Zoology."

FIG. 1.

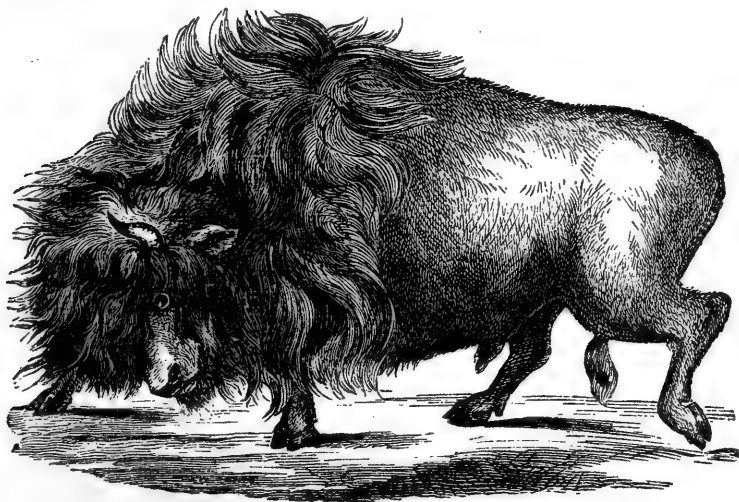

AMERICAN BUFFALO. (Tenney.)

As furs are generally worn by those who consult taste rather than necessity, their use depends very much upon fashion and caprice. Hence their price varies much at different times, and is not always regulated by their intrinsic value. As it is natural to prefer articles that are rare and far-fetched, and as furs can be easily carried to any part of the world, most prefer foreign to domestic furs of the same quality. Thus we export much of our fox, marten, fisher, otter, beaver, and muskrat fur, while we import Astrakhan, Russian sable, ermine, Siberian squirrel, French rabbit, or cony, chinchilla, and nutria fur.

At the present time, much of the fur worn is colored. In some cases, the hair, fur, and skin, are all colored; as the Astrakhan: but in most cases the end of the hair or fur only is tinted, while the skin re-

mains untouched. The object of the tinting appears to be, to make all parts of the fur on a skin of the same color; to make an inferior fur appear like a superior one of the same kind; or to make the fur of one animal pass for that of another; as, for instance, the marten for the sable. Dyed furs are generally not durable—soon fade, and ap-

FIG. 2.



SABLE.

pear as if old and worn. Hair and fur frequently grow together on fur-bearing animals; and, if the fur alone be wanted, the hair, which is usually longer than the fur, must be plucked or otherwise removed. During the spring and summer the fur of many land animals fades, and is shed for the season; leaving nothing but hair remaining, or perhaps

FIG. 3.

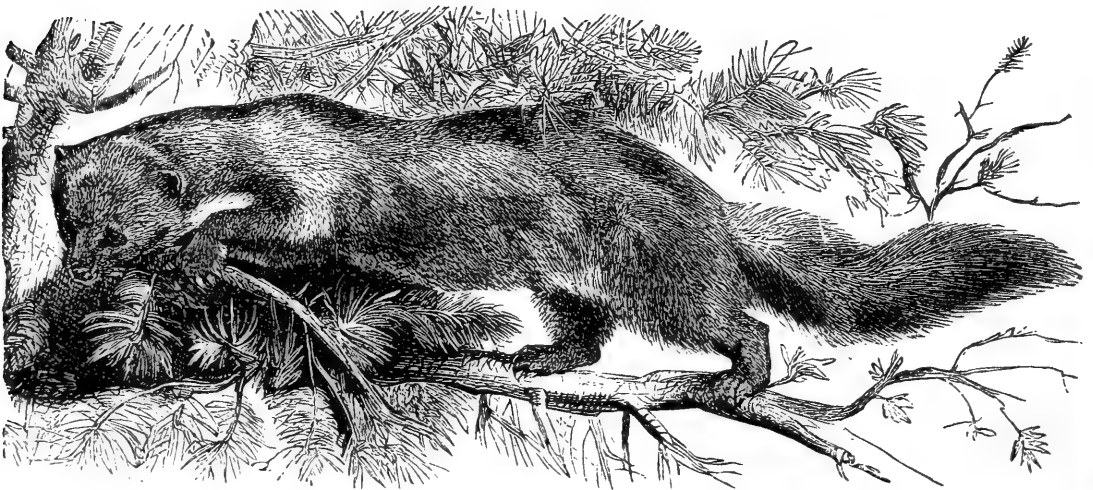

PINE MARTEN.

fur inferior in color and fineness. In the autumn, a new coat of the animal's finest fur is grown, which has comparative freshness and brilliancy of color. Furs, taken in the best season in the higher latitudes,

are called prime; those taken out of season are, in common parlance, said to be *stagy*.

Other things being the same, the colder the climate the better the fur. Hence our best furs are generally obtained in the higher latitudes, or in cool mountain-regions, during the prevalence of snow and the severity of winter. Thus the hunter is exposed to much labor, fatigue, privation, and danger. They who, in the inhospitable clime of Siberia, hunt the sable, in the most inclement season of the year, undergo intense suffering and hardship.

FIG. 4.



MINK.

Sables are three or four times as large as the common weasel, to which family they belong. They are usually taken between November and February, in snares, traps, or pitfalls, baited with flesh or fish. They are then of a beautiful black color, but are brownish in summer. The fur of the Russian sable, by its richness and elegance, maintains its preëminence. It may be distinguished from all other furs, by the hairs turning and lying with equal ease in either direction; which may be shown by blowing it. It is limited in quantity, only about 15,000 being caught yearly, and the price of the best is almost fabulous: a furrier suggests from \$20 to \$150 per skin. Fresh furs have what dealers call a bloomy appearance. Dyed sables generally lose their gloss, whether the lower hair has taken the dye or not; and the hairs are twisted or crisped. Some smoke the skins to blacken them, but the smell and crisped hairs betray the cheat. To detect dyeing or smoking, rub the fur with a moist linen cloth, which will then be blackened. The Chinese, however, dye the sables so that the color lasts, and the fur keeps its gloss; then, the fraud can be detected only by the crisped hairs.

The fur of the pine marten is nearly equal to that of the sable. Its color is a lustrous brown, and it is frequently tinted so as to resemble the real sable; and efforts are said to have been sometimes made to palm it upon buyers as the genuine Russian. That which is obtained in America, some 200,000 skins annually, which is somewhat better than the European, is usually called, by dealers, Hudson Bay sable. It is an excellent and valuable fur, very full and soft, and, like the Russian sable, is much used for muffs, capes, collars, boas, and other kinds of fancy furs. The fur of the beech or stone marten is much inferior to that of the sable or pine marten. It is of a yellowish brown, and, though often colored to represent pine marten or sable, the practised eye can easily distinguish it from them. The best specimens of the fur are obtained in Europe, where it is much used; but in this country, at the present time, it is not used at all. The skins of the fisher or pennant's marten, whose fur is quite valuable, are also exported. Less than 10,000 are caught yearly.

FIG. 5.

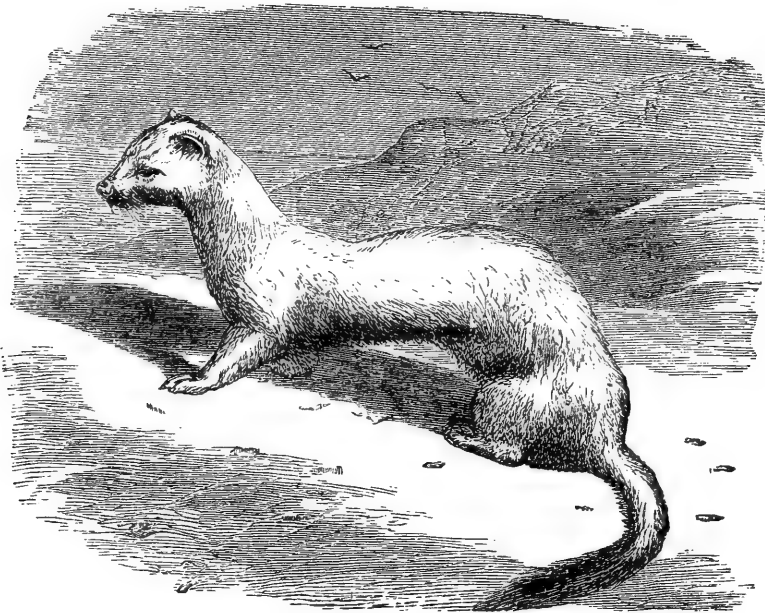

ERMINE, OR STOAT.

The mink is constantly found in almost every part of North America, some 250,000 being taken annually; yet, contrary to the general rule, it has been a very fashionable fur here for several years, for muffs, collars, etc. The color of the finest is chestnut-brown, glossed with black. The lighter colored is of less value, but it is often dyed so as to deceive the ignorant or unobserving. Dealers sometimes call it American sable. We occasionally hear of attempts to tame the mink, and raise it on a large scale in a minkery or suitable place of confinement. The present high price of the fur presents a strong inducement, but I do not know that there is any prospect of success.



The ermine is abundant in the northern parts of Asia, Europe, and America, about 400,000 being taken yearly. It is much smaller than the sable. In summer it is of a yellowish brown, and is then called a stoat; and its fur is known among furriers by the name of *roselet*. In winter, at the north, it becomes a pure white, and extremely beautiful. Farther south, the change from brown to white is less perfect. The end of the tail remains black during the year. It was formerly very valuable, and was much used in England to line the official robes of judges and magistrates. It is still considered a choice fur. The color of the Canada lynx is light gray, waved with black. Its fur is long, fine, and very thick, and furnishes a most beautiful material for robes, ladies' sets, trimmings, etc. Some 50,000 skins are sent to market each year. The Siberian squirrel is a neat, lively, active little animal. Its fur in winter is short and silky, and of a pretty gray color. The skins are used quite extensively for making ladies' sets and children's furs; several millions being taken annually.

FIG. 6.



CANADA LYNX. (Tenny.)

The seal is a quadruped which spends the larger portion of its time in the water, and whose shape very much resembles that of a fish. Its neck is short, its body is tapering from the shoulders, and its legs or flippers very much resemble fins. It can stay a long time under water without breathing, at which time it can close its nostrils and ears. The species are numerous, differ greatly in size, and are found in almost every part of the world, but abound mostly in the higher latitudes. They live upon fish and other aquatic animals, eat their food in the water, but in fine weather they prefer the ice, or the rocks and sand on shore, on which to sleep, to bask in the sun, or to play. The harp seal furnishes the Esquimaux and Greenlanders with food, clothing, light, covering for their boats, and other articles of convenience. The eyes of seals are dark and lustrous, their sense of hearing acute, and they delight in musical sounds. Their heads so much resemble the human form, and their movements are so graceful, that the ancient

poets found no difficulty in transforming them, in imagination, into tritons, sirens, nereids, etc., and making them the companions of Neptune. The tales of mermaids and mermen, by modern sailors, are usually caused by them, though the manatus may sometimes be the cause of the illusion. Several species have a fine, close fur. Others, like the common seal, have only coarse hair. The skins of these, when dressed with the hair on, are used to cover trunks, to make gloves, soldiers' caps, etc. The skins of the sea-bear, or fur-seal, are extensively used for gentlemen's and ladies' sets, and for various other purposes. The

FIG. 7.

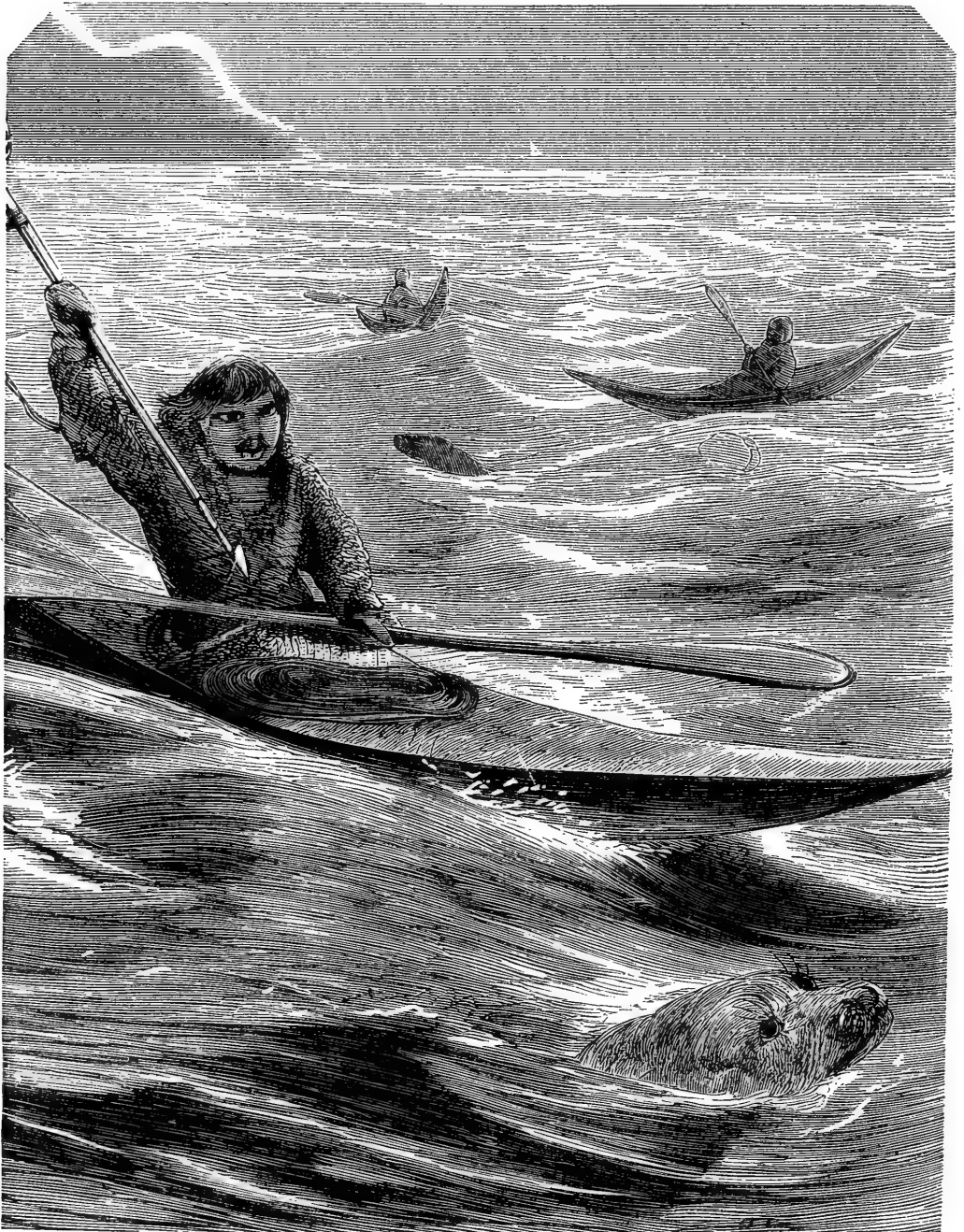

ESQUIMAUX SPEARING SEALS.

original color of the fur varies from black, through brownish red to ash-colored; and the dyer gives it whatever tint the market requires. The skins have long hairs, black, brown, or gray, which are taken out before the fur is in a condition to use. The number of seals of all kinds, now taken yearly, is not far from 1,000,000.

FIG. 8.



OTTER. (Tenney.)

A few years ago, a large number of skins, of what was then called in Britain the common fur-seal of commerce, was obtained from the islands of the Southern Ocean. Instead of taking a moderate number, and allowing the supply to be kept up, those engaged in the business made an indiscriminate slaughter of the animals, and in a few years

FIG. 9.



BEAVER. (Tenney.)

nearly exterminated them. In South Shetland, it was estimated that they killed 320,000; in the Island of Desolation, or Kerguelen, more than 1,000,000; and in South Georgia 1,200,000. The fur of this seal is

of a uniform brownish-white color above, and of a somewhat deep brown beneath. The fur-skin of this valuable animal is prepared in a peculiar manner. The long hair which conceals the fur is first removed, by heating the skin, and then carding it with a large wooden knife. The fur then appears in all its perfection, and was formerly much used in Europe for linings and borders of cloaks and mantles, for caps, etc.

FIG. 10.



INDIANS CATCHING MUSK-RATS.

But by far the most valuable fur that passes under the name of seal is that of the sea-otter, or Alaska seal, which, while it has the habits of the seal, forms a connecting link between it and the otter. A large portion of this fur is obtained from two islands, St. Paul and St. George, in latitude about  $56\frac{1}{2}^{\circ}$  north, in the Sea of Behring or Kamtchatka, about 250 miles northwest of the peninsula of Alaska. These islands were sold by Russia to the United States as a part of

the Alaska territory. When, in 1869, General George H. Thomas was sent by our government to examine and report upon the country, he estimated the fur-bearing seals, or sea-otters, seen each summer on these islands, at from 5,000,000 to 15,000,000, lying in the rookeries, and covering hundreds of acres. For the last fifty or sixty years, the Russian Government had limited the number of skins to be taken yearly to some 80,000 or less. As General Thomas recommended that the hunting and killing of these animals should be regulated by law, Congress, in 1870, adopted substantially the Russian system; and in a few weeks the Alaska Company, of which Hon. Henry P. Haven,

FIG. 11.



CHINCHILLA.

of New London, Connecticut, is a prominent owner and influential officer, leased from the United States the islands of St. Paul and St. George. The company contracted to pay a rent of \$55,000 per annum, and a revenue tax of \$2.62½ on each fur-seal taken and shipped from the islands. Two United States officials are stationed on each of these islands to see that the company complies with the conditions of the lease, and to count the skins as they are shipped to San Francisco, where they are again counted by the custom-house officers. The number taken annually must not exceed 100,000. The catch in 1872 amounted to 96,069 skins. The sea-otter is the boldest swimmer of the amphibious tribe, for troops of them are met with 300 miles from land. When holding a fore-paw over their eyes, in order to look about them with more distinctness, they are called sea-apes. They are exclusively found in the North Pacific Ocean and on its borders, between the 49th and 60th degrees of latitude; and, although living mostly in the water, they are occasionally found on land very far from



the sea. Their fur is exceedingly fine, close, soft, and velvety, perfectly black in full season, but at other times of a shining, deep sepia, or of a rich chestnut-brown. The longer hairs are silky and glossy, but not very numerous, and are easily removed. The Chinese prize the fur of the sea-otter so highly that formerly they paid for the skins from sixty to seventy-five dollars each; but they value them somewhat less now. It still remains the choicest, most expensive, and most fashionable, fur of its kind in the market for gentlemen's sets, ladies' sacques, turbans, boas, muffs, etc., and consequently all inferior furs that resemble it are made to imitate it.

Otters are fierce, wild, and shy, nocturnal in their habits, live much in the water, and feed upon fish, which they catch with great dexterity. They love to sport by sliding down a bank of snow in winter,

FIG. 12.



ARCTIC FOX.

or clay in summer, especially when they can, at the bottom, plunge into water. The Canadian otter has long, glossy hair, of a dark color, and an inner fur, close, fine, and soft, of a deep, rich liver-brown. If the fur on any part of the skin lacks the right color, it is brought to the requisite tint by dyeing. The fur is much esteemed, and is used for caps, collars, gloves, etc., though much of it is exported to Europe. The number of otters taken yearly is supposed to be about 40,000.

Beavers have a broad, horizontally-flattened, and scaly tail, a webbed hind-foot, and a general form which is admirable for swimming. They live mostly in and near the water, in large companies,



and their chief food is bark and aquatic plants, which they collect in large heaps for the winter. Their powerful teeth enable them to gnaw down trees, even of the hardest wood. To obtain a proper depth of running water, with a surface varying little in height, they build a dam on a stream to make a pond, in which to build houses for winter, using trees and branches mixed with stones and mud. They cut their wood up-stream, and float it down. The houses are built where the

FIG. 13.



RACCOON. (Tenney.)

water is several feet deep, and their only entrance is at the bottom. They are continued so much above the water as to admit of an upper, dry apartment, approached from the lower, and usually occupied by two or three families. The fur of the American beaver is of a uniform reddish brown, fine, thick, and of the best quality. It was formerly almost wholly used for making hats. It is used for that now; also for gentlemen's caps, mufflers, and gloves. A large portion of it is exported to England.

FIG. 14.



BADGER. (Tenney.)

Nutria fur is obtained from the coypou, or couia, a South American animal resembling the beaver in size and habits, but having a long, round tail. Its similarity, or that of its fur, to the otter and muskrat, may be inferred from its names: *nutria* meaning otter, and *myopotamus* river-mouse. In fact, Molina speaks of the coypou as a species of water-rat, of the size and color of the otter. In the workshops it is called the South American monkey. It has long, ruddy hair, and a

short, brownish, ash-colored fur, of considerable value, which has been largely exported to Europe for making hats. It has also been much used here for hats, gentlemen's sets, and other purposes. The fur somewhat resembles that of the beaver, as well as the otter. It is estimated that 3,000,000 are caught annually.

The muskrat, or musquash, is a native of North America, much smaller than the beaver, but with habits and appearance somewhat similar. Muskrats feed upon mussels, aquatic plants, and roots of grasses, and build winter-huts of sticks, grass, and mud, with an entrance under water, leading to a dry apartment above. In summer they dwell in extensive burrows along the banks of the rivers. The trapper, walking on the bank, hears the muskrat run from his hole into the water, observes where he stirs the mud, and puts the trap quietly down there. The number of skins taken yearly by trap and gun is immense; over 3,000,000. Many are manufactured into hats on both sides of the Atlantic, more than a million being exported annually to England for that purpose. Besides hats, they are used here largely for men's gloves, ladies' sets, robes, etc. They are frequently dyed to imitate mink, and are then called Alaska mink. They are also plucked and dyed to imitate seal and similar furs.

FIG. 15.

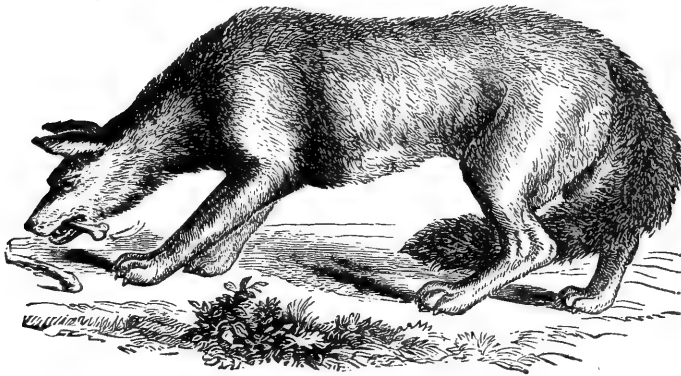

WOLF. (Tenney.)

The chinchilla is scarcely larger than a rat, and inhabits the cold mountain-regions of Chili and Peru. It is chiefly remarkable for its exquisitely fine fur, which is very soft, and of a pearly gray. It is used for ladies' and children's sets, but more especially for lining and trimming cloaks, pelisses, and other articles of clothing. Not more than 100,000 are taken yearly.

The fur of the northern hare, which is white in winter and brown in summer, is mostly used in the manufacture of hats. The skins of the common European rabbit or French cony are used for ladies' sets and children's furs. The fur is also used for hats. Several millions are taken each year.

The fur of the skunk is used, under the name of Alaska sable, for

ladies' sets, sacque-trimmings, etc., of an inferior quality. The black portions of the skin are sometimes carefully selected, completely deodorized, made into sets of furs of the natural color, and sold under the name of black marten. The pole-cat, or fitchet weasel, has long, coarse, dark-brown hair, and an under-coat of short, silky, pale-yellow fur. This fur, though inferior, is imported and used for ladies' sets, etc., and is sold under the name of fitch. The Virginia opossum has the habit of feigning itself dead if slightly struck or wounded, but, if seriously attacked and badly hurt, it will fight bravely. Its fur is a long, woolly down, which is of a dingy white. Though of little value, the fur is colored so as to resemble fitch, and is sold under that name.

The color of the arctic fox during winter is a pure white; in summer, brown, gray, or bluish. It is then called a cross or pied fox. The fur is long, fine, and woolly, and is occasionally used here for ladies' sets and other purposes, but it is mostly exported to Europe;

FIG. 16.



WOLVERINE. (Tenney.)

as are also the skins of the red fox and its varieties, the cross fox and the silver or black fox. The color of an adult silver fox when in prime fur is a deep, glossy black, with a silvery grizzle on the forehead and flanks. This variety is extremely rare, and its rich fur is more valuable than that of any other quadruped. The skin of the silvery fox of Labrador has been sold in London for \$500.

The panda, or wah, of the Himalaya Mountains, is about the size of a large cat. It is covered with a soft, thickly-set fur, which, above, is of the richest cinnamon red; behind, of a fawn color; and, beneath, of a deep black—while its head is whitish, and its tail like a lady's boa, and banded with red and yellow. Fred. Cuvier calls this the most beautiful of known quadrupeds.

The color of the raccoon is light gray overlaid with black-tipped hairs. The outer hair is long and coarse, the inner softer and more like wool. The fur is mostly used for making hats. It is sometimes

used for robes, as linings for garments, etc. About 500,000 skins are taken yearly. The hair of the badger is fine, silky, and very long, especially behind. At the roots it is of a yellowish gray, black in the middle, and white at the tip. The skins were formerly made into pouches by the Highlanders. The dressed skins make the best pistol-furniture, and the hair is much used to make artists' brushes for spreading the colors and softening the shades in painting. Some 50,000 skins are sent to market annually.

The white or polar bear is an enormous animal, weighing sometimes 1,000 or 1,500 pounds; is wholly carnivorous, and feeds upon seals and other animals. The fur is long, fine, soft, woolly, and of a silvery-white color tinged with yellow. Its skin makes a magnificent robe. In the northern regions the skins of bears furnish the most useful and comfortable winter apparel. They are made into beds, coverlets, caps, gloves, and other articles of clothing. The black bear has hair comparatively soft and glossy. Its skin is used for hammer-cloths of carriages, pistol-holsters, rugs, caps, etc. The cinnamon bear of the Rocky Mountains has a more valuable fur than that of the black bear, of which it appears to be a variety.

There are various other animals that furnish robes of different quality and appearance, such as the wolverine, or glutton, the wild-cat, the coyote, or prairie-wolf, the different varieties of the white wolf, which is sometimes called the mountain or timber wolf. The growing scarcity of wild animals, and the resources of modern art, are gradually introducing into use various fabrics as artificial robes, many of them convenient and comfortable, and some of them even elegant and very desirable.



## CORRELATION OF VITAL WITH CHEMICAL AND PHYSICAL FORCES.<sup>1</sup>

BY JOSEPH LE CONTE,

PROFESSOR OF GEOLOGY AND NATURAL HISTORY IN THE UNIVERSITY OF CALIFORNIA.

VITAL force; whence is it derived? What is its relation to the other forces of Nature? The answer of modern science to these questions is: It is derived from the lower forces of Nature; it is related to other forces much as these are related to each other—it is correlated with chemical and physical forces.

At one time matter was supposed to be destructible. By combustion or by evaporation matter seemed to be consumed—to pass out of existence; but now we know it only changes its form from the solid

<sup>1</sup> An abstract of two Lectures given to the class in Comparative Physiology in the University of California.

or liquid to the gaseous condition—from the visible to the invisible—and that amid all these changes the same quantity of matter remains. Creation or destruction of matter, increase or diminution of matter, lies beyond the domain of Science; her domain is confined entirely to the changes of matter. Now, it is the doctrine of modern science that the same is true of force. Force seems often to be annihilated. Two cannon-balls of equal size and velocity meet each other and fall motionless. The immense energy of these moving bodies seems to pass out of existence. But not so; it is changed into heat, and the exact amount of heat may be calculated; moreover, an equal amount of heat may be changed back again into an equal amount of momentum. Here, therefore, force is not lost, but is changed from a visible to an invisible form. Motion is changed from bodily motion into molecular motion. Thus heat, light, electricity, magnetism, chemical affinity, and mechanical force, are transmutable into each other, back and forth; but, amid all these changes, the amount of force remains unchanged. Force is incapable of destruction, except by the same power which created it. The domain of Science lies within the limits of these changes—creation and annihilation lie outside of her domain.

The mutual convertibility of forces into each other is called *correlation of forces*; the persistence of the same amount, amid all these protean forms, is called *conservation of force*.

The correlation of physical forces with each other and with chemical force is now universally acknowledged and somewhat clearly conceived. The correlation of vital force with these is not universally acknowledged, and, where acknowledged, is only imperfectly conceived. In 1859 I published a paper<sup>1</sup> in which I attempted to put the idea of correlation of vital force with chemical and physical forces in a more definite and scientific form. The views expressed in that paper have been generally adopted by physiologists. Since the publication of the paper referred to, the subject has lain in my mind, and grown at least somewhat. I propose, therefore, now to reëmbody my views in a more popular form, with such additions as have occurred to me since.

There are four planes of material existence, which may be represented as raised one above another. These are: 1. The plane of elementary existence; 2. The plane of chemical compounds, or mineral kingdom; 3. The plane of vegetable existence; and, 4. The plane of animal existence. Their relations to each other are truly expressed by writing them one above the other, thus:

4. *Animal Kingdom.*
3. *Vegetable Kingdom.*
2. *Mineral Kingdom.*
1. *Elements.*

<sup>1</sup> *American Journal of Science*, November, 1859. *Philadelphia Magazine*, vol. xix., p. 133.

Now, it is a remarkable fact that there is a special force, whose function it is to raise matter from each plane to the plane above, and to execute movements on the latter. Thus, it is the function of chemical affinity alone to raise matter from No. 1 to No. 2, as well as to execute all the movements, back and forth, by action and reaction; in a word, to produce all the phenomena on No. 2 which together constitute the science of chemistry. It is the prerogative of vegetable life-force alone to lift matter from No. 2 to No. 3, as well as to execute all the movements on that plane, which together constitute the science of vegetable physiology. It is the prerogative of animal life-force alone to lift matter from No. 3 to No. 4, and to preside over the movements on this plane, which together constitute the science of animal physiology. But there is no force in Nature capable of raising matter at once from No. 1 to No. 3, or from No. 2 to No. 4, without stopping and receiving an accession of force, of a different kind, on the intermediate plane. Plants cannot feed upon elements, but only on chemical compounds: animals cannot feed on minerals, but only on vegetables. We will see in the sequel that this is the necessary result of the principle of conservation of force in vital phenomena.

It is well known that atoms, in a nascent state, i. e., at the moment of their separation from previous combination, are endowed with peculiar and powerful affinity. Oxygen and nitrogen, nitrogen and hydrogen, hydrogen and carbon, which show no affinity for each other under ordinary circumstances, readily unite when one or both are in a nascent condition. The reason seems to be that, when the elements of a compound are torn asunder, the chemical affinity which previously bound them together is set free, ready and eager to unite the nascent elements with whatever they come in contact with. This state of exalted chemical energy is retained but a little while, because it is liable to be changed into some other form of force, probably heat, and is therefore no longer chemical energy. To illustrate by the planes: matter falling down from No. 2 to No. 1 generates force by which matter is lifted from No. 1 to No. 2. Decomposition generates the force by which combination is effected. This principle underlies every thing I shall further say.

There are, therefore, two ideas or principles underlying this paper: 1. The correlation of vital with physical and chemical forces; 2. That in all cases vital force is produced by decomposition—is transformed by nascent affinity. Neither of these is new. Grove, many years ago, brought out, in a vague manner, the idea that vital force was correlated with chemical and physical forces.<sup>1</sup> In 1848 Dr. Freke, M. R. I. A., of Dublin, first advanced the idea that vital force of animal life was generated by decomposition. In 1851 the same idea was brought out again by Dr. Walters, of St. Louis. These papers were un-

<sup>1</sup> In 1845 Dr. J. R. Mayer published a paper on "Organic Motion and Nutrition." I have not seen it.



known to me when I wrote my article. They have been sent to me in the last few years by their respective authors. Neither of these authors, however, extends this principle to vegetation, the most fundamental and most important phenomenon of life. In 1857 the same idea was again brought out by Prof. Henry, of the Smithsonian Institution, and by him extended to vegetation. I do not, therefore, now claim to have first advanced this idea, but I do claim to have in some measure rescued it from vagueness, and given it a clearer and more scientific form.

I wish now to apply these principles in the explanation of the most important phenomena of vegetable and animal life :

1. VEGETATION.—The most important phenomenon in the life-history of a plant—in fact, the starting-point of all life, both vegetable and animal—is the formation of organic matter in the leaves. The necessary conditions for this wonderful change of mineral into organic matter seem to be, sunlight, chlorophyl, and living protoplasm, or bioplasm. This is the phenomenon I wish now to discuss.

The plastic matters of which vegetable structure is built are of two kinds—amyloids and albuminoids. The amyloids, or starch and sugar groups, consist of C, H, and O ; the albuminoids of C, H, O, N, and SP. The quantity of sulphur and phosphorus is very small, and we will neglect them in this discussion. The food out of which these substances are elaborated are,  $\text{CO}_2$ ,  $\text{H}_2\text{O}$ , and  $\text{H}_3\text{N}$ —carbonic acid, water, and ammonia. Now, by the agency of sunlight in the presence of chlorophyl and bioplasm, these chemical compounds ( $\text{CO}_2$ ,  $\text{H}_2\text{O}$ ,  $\text{H}_3\text{N}$ ) are torn asunder, or shaken asunder, or decomposed ; the excess of O, or of O and H, is rejected, and the remaining elements in a nascent condition combine to form organic matter. To form the amyloids, starch, dextrine, sugar, cellulose, only  $\text{CO}_2$  and  $\text{H}_2\text{O}$  are decomposed, and excess of O rejected. To form albuminoids or protoplasm,  $\text{CO}_2$ ,  $\text{H}_2\text{O}$ , and  $\text{H}_3\text{N}$ , are decomposed, and excess of O and H rejected.

It would seem in this case, therefore, that physical force (light) is changed into nascent chemical force, and this nascent chemical energy, under the peculiar conditions present, forms organic matter and reappears as vital force. Light falling on living green leaves is destroyed or consumed in doing the work of decomposition ; disappears as light, to reappear as nascent chemical energy ; and this in its turn disappears in forming organic matter, to reappear as the vital force of the organic matter thus formed. The light which disappears is proportioned to the O, or the O and H rejected ; is proportioned also to the quantity of organic matter formed, and also to the amount of vital force resulting. To illustrate : In the case of amyloids, oxygen-excess falling or running down from plane No. 2 to plane No. 1 generates force to raise C, H, and O, from plane No. 2 to plane No. 3. In the case of albuminoids, oxygen-excess and hydrogen-excess running down from No. 2 to No. 1 generate force to raise C, H, O, and N, from No. 2 to

No. 3. To illustrate again: As sun-heat falling upon water disappears as heat, to reappear as mechanical power, raising the water into the clouds, so sunlight falling upon green leaves disappears as light, to reappear as vital force lifting matter from the mineral into the organic kingdom.

2. GERMINATION.—Growing plants, it is seen, take their life-force from the sun; but seeds germinate and commence to grow in the dark. Evidently there must be some other source from which they draw their supply of force. They cannot draw force from the sun. This fact is intimately connected with another fact, viz., that they do not draw their food from the mineral kingdom. The seed in germination feeds entirely upon a supply of organic matter laid up for it by the mother-plant. It is the decomposition of this organic matter which supplies the force of germination. Chemical compounds are comparatively stable—it requires sunlight to tear them asunder; but organic matter is more easily decomposed—it is almost spontaneously decomposed. It may be that heat (a necessary condition of germination) is the force which determines the decomposition. However this may be, it is certain that a portion of the organic matter laid up in the seed is decomposed, burned up, to form  $\text{CO}_2$  and  $\text{H}_2\text{O}$ , and that this combustion furnishes the force by which the mason-work of tissue-making is accomplished. In other words, of the food laid up in the form of starch, dextrine, protoplasm, a portion is decomposed to furnish the force by which the remainder is organized. Hence the seed always loses weight in germination; it cannot develop unless it is in part consumed; “it is not quickened except it die.” This self-consumption continues until the leaves and roots are formed; then it begins to draw force from the sun, and food from the mineral kingdom.

To illustrate: In germination, matter running down from plane No. 3 to plane No. 2 generates force by which other similar matter is moved about and raised to a somewhat higher position on plane No. 3. As water raised by the sun may be stored in reservoirs, and in running down from these may do work, so matter raised by sun-force into the organic kingdom by one generation is stored as force to do the work of germination of the next generation. Again, as, in water running through an hydraulic ram, a portion runs to waste, in order to generate force to lift the remainder to a higher level, so, of organic matter stored in the seed, a portion runs to waste to create force to organize the remainder.

Thus, then, it will be seen, that three things, viz., the absence of sunlight, the use of organic food, and the loss of weight, are indissolubly connected in germination, and all explained by the principle of conservation of force.

3. STARTING OF BUDS.—Deciduous trees are entirely destitute of leaves during the winter. The buds must start to grow in the spring without leaves, and therefore without drawing force from the sun.

Hence, also, food in the organic form must be, and is, laid up from the previous year in the body of the tree. A portion of this is consumed with the formation of  $\text{CO}_2$  and  $\text{H}_2\text{O}$ , in order to create force for the development of the buds. So soon as by this means the leaves are formed, the plant begins to draw force from the sun, and food from the mineral kingdom.

4. PALE PLANTS.—Fungi and etiolated plants have no chlorophyl, therefore cannot draw their force from the sun, nor make organic matters from inorganic. Hence these also must feed on organic matter: not, indeed, on starch, dextrine, and protoplasm, but on decaying organic matter. In these plants the organic matter is taken up in some form intermediate between the planes No. 3 and No. 2. The matter thus taken up is, a portion of it, consumed with the formation of  $\text{CO}_2$  and  $\text{HO}$ , in order to create force necessary to organize the remainder. To illustrate: Matter falling from some intermediate point between No. 2 and No. 3 to No. 2, produces force sufficient to raise matter from the same intermediate point to No. 3; a portion runs to waste downward, and creates force to push the remainder upward.

5. GROWTH OF GREEN PLANTS AT NIGHT.—It is well known that almost all plants grow at night as well as in the day. It is also known that plants at night exhale  $\text{CO}_2$ . These two facts have not, however, as far as I know, been connected with one another, and with the principle of conservation of force. It is usually supposed that in the night the decomposition of  $\text{CO}_2$  and exhalation of oxygen are checked by withdrawal of sunlight, and some of the  $\text{CO}_2$  in the ascending sap is exhaled by a physical law. But this does not account for the growth. It is evident that, in the absence of sunlight, the force required for the work of tissue-building can be derived only from the decomposition and combustion of organic matter. There are two views as to the source of this organic matter, either or both of which may be correct: First. There seems to be no doubt that most plants, especially those grown in soils rich in *humus*, take up a portion of their food in the form of semi-organic matter, or soluble *humus*. The combustion of a portion of this in every part of the plant, by means of oxygen also absorbed by the roots, and the formation of  $\text{CO}_2$ , undoubtedly creates a supply of force night and day, independently of sunlight. The force thus produced by the combustion of a portion might be used to raise the remainder into starch, dextrine, etc., or might be used in tissue-building. During the day, the  $\text{CO}_2$  thus produced would be again decomposed in the leaves by sunlight, and thus create an additional supply of force. During the night, the  $\text{CO}_2$  would be exhaled.<sup>1</sup>

Again: It is possible that more organic matter is made by sunlight during the day than is used up in tissue-building. Some of this excess is again consumed, and forms  $\text{CO}_2$  and  $\text{H}_2\text{O}$ , in order to con-

<sup>1</sup> For more full account, see my paper, *American Journal of Science*, November, 1859, sixth and seventh heads.

tinue the tissue-building process during the night. Thus the plant during the day stores up sun-force sufficient to do its work during the night. It has been suggested by Dr. J. C. Draper,<sup>1</sup> though not proved, or even rendered probable, that the force of tissue-building (*force plastique*) is always derived from decomposition, or combustion of organic matter. In that case, the force of organic-matter formation is derived from the sun, while the force of tissue-building (which is relatively small) is derived from the combustion of organic matter thus previously formed.

6. FERMENTATION.—The plastic matters out of which vegetable tissue is built, and which are formed by sunlight in the leaves, are of two kinds, viz., amyloids (dextrine, sugar, starch, cellulose), and albuminoids, or protoplasm. Now, the amyloids are comparatively stable, and do not spontaneously decompose; but the albuminoids not only decompose spontaneously themselves, but drag down the amyloids with which they are associated into concurrent decomposition—not only change themselves, but propagate a change into amyloids. Albuminoids, in various stages and kinds of decomposition, are called ferments. The propagated change in amyloids is called fermentation. By various kinds of ferments, amyloids are thus dragged down step by step to the mineral kingdom, viz., to  $\text{CO}_2$  and  $\text{H}_2\text{O}$ . The accompanying table exhibits the various stages of the descent of starch, and the ferments by which they are effected:<sup>2</sup>

1. Starch .....	}	Diastase.
2. Dextrine .....		
3. Sugar .....		
4. Alcohol and $\text{CO}_2$ .....		Yeast.
5. Acetic acid .....		Mother of vinegar.
6. $\text{CO}_2$ and $\text{HO}$ .....		Mould.

By appropriate means, the process of descent may be stopped on any one of these planes. By far too much is, unfortunately, stopped on the fourth plane. The manufacturer and chemist may determine the downward change through all the planes, and the chemist has recently succeeded in ascending again to No. 4; but the plant ascends and descends the scale at pleasure (avoiding, however, the fourth and fifth), and even passes at one step from the lowest to the highest.

Now, it will be seen by the table that, connected with each of these descensive changes, there is a peculiar ferment associated. Diastase determines the change from starch to dextrine and sugar—saccharification; yeast, the change from sugar to alcohol—fermentation; mother of vinegar, the change from alcohol to acetic acid—acetification; and a peculiar mould, the change from acetic acid to  $\text{CO}_2$  and water. But

<sup>1</sup> *American Journal of Science*, November, 1872. The experiments of Dr. Draper are inconclusive, because they are made on *seedlings*, which, until their supply of organic food is exhausted, are independent of sunlight.

<sup>2</sup> J. C. Draper, *American Journal of Science*, November, 1872

what is far more wonderful and significant is, that, associated with each of these ferments, except diastase, and therefore with each of these descensive changes, except the change from starch to sugar, or saccharification, there is a peculiar form of life. Associated with alcoholic fermentation, there is the yeast-plant; with acetification, the vinegar-plant; and, with the decomposition of vinegar, a peculiar kind of mould. We will take the one which is best understood, viz., yeast-plant (*saccharomyce*), and its relation to alcoholic fermentation.

It is well known that, in connection with alcoholic fermentation, there is a peculiar unicelled plant which grows and multiplies. Fermentation never takes place without the presence of this plant; this plant never grows without producing fermentation, and the rapidity of the fermentation is in exact proportion to the rapidity of the growth of the plant. But, as far as I know, the fact has not been distinctly brought out that the decomposition of the sugar into alcohol and carbonic acid furnishes the force by which the plant grows and multiplies. If the growing cells of the yeast-plant be observed under the microscope, it will be seen that the carbonic-acid bubbles form, and therefore probably the decomposition of sugar takes place only in contact with the surface of the yeast-cells. The yeast-plant not only assimilates matter, but also force. It decomposes the sugar, in order that it may assimilate the chemical force set free.

We have already said that the change from starch to sugar, determined by diastase (saccharification), is the only one in connection with which there is no life. Now, it is a most significant fact, in this connection, that this is also the only change which is not, in a proper sense, descensive, or, at least, where there is no decomposition.

We now pass from the phenomena of vegetable to the phenomena of animal life.

7. DEVELOPMENT OF THE EGG IN INCUBATION.—The development of the egg in incubation is very similar to the germination of a seed. An egg consists of albuminous and fatty matters, so inclosed that, while oxygen of the air is admitted, nutrient matters are excluded. During incubation the egg changes into an embryo; it passes from an almost unorganized to a highly-organized condition, from a lower to a higher condition. There is work done: there must be expenditure of force; but, as we have already seen, vital force is always derived from decomposition. But, as the matters to be decomposed are not taken *ab extra*, the egg must consume itself; that it does so, is proved by the fact that in incubation the egg absorbs oxygen, eliminates  $\text{CO}_2$  and probably  $\text{H}_2\text{O}$ , and loses weight. As in the seed, a portion of the matters contained in the egg is consumed in order to create force to organize the remainder. Matter runs down from plane No. 4 to plane No. 2, and generates force to do the work of organization on plane No. 4. The amount of  $\text{CO}_2$  and  $\text{H}_2\text{O}$  formed, and therefore the loss of weight, is a measure of the amount of plastic work done.

8. DEVELOPMENT WITHIN THE CHRYSALIS SHELL.—It is well known that many insects emerge from the egg not in their final form, but in a wormlike form, called a larva. After this they pass into a second passive state, in which they are again covered with a kind of shell—a sort of second egg-state, called the chrysalis. From this they again emerge as the perfect insect. The butterfly is the most familiar, as well as the best illustrated, of these changes. The larva or caterpillar eats with enormous voracity, and grows very rapidly. When its growth is complete, it covers itself with a shell, and remains perfectly passive and almost immovable for many days or weeks. During this period of quiescence of animal functions there are, however, the most important changes going on within. The wings and legs are formed, the muscles are aggregated in bundles for moving these appendages, the nervous system is more highly developed, the mouth, organs, and alimentary canal, are greatly changed and more highly organized, the simple eyes are changed into compound eyes. Now, all this requires expenditure of force, and therefore decomposition of matter; but no food is taken, therefore the chrysalis must consume its own substance, and therefore lose weight. It does so; the weight of the emerging butterfly is in many cases not one-tenth that of the caterpillar. Force is stored up in the form of organic matter only to be consumed in doing plastic work.

9. MATURE ANIMALS.—Whence do animals derive their vital force? I answer, from the decomposition of their food and the decomposition of their tissues.

Plants, as we have seen, derive their vital force from the decomposition of their mineral food. But the chemical compounds on which plants feed are very stable. Their decomposition requires a peculiar and complex contrivance for the reception and utilization of sunlight. These conditions are wanting in animals. Animals, therefore, cannot feed on chemical compounds of the mineral kingdom; they must have organic food, which easily runs into decomposition; they must feed on the vegetable kingdom.

Animals are distinguished from vegetables by incessant decay in every tissue—a decay which is proportional to animal activity. This incessant decay necessitates incessant repair, so that the animal body has been likened to a temple on which two opposite forces are at work in every part, the one tearing down, the other repairing the breach as fast as made. In vegetables no such incessant decay has ever been made out. If it exists, it must be very trifling in comparison. Protoplasm, it is true, is taken up from the older parts of vegetables, and these parts die; but the protoplasm does not seem to decompose, but is used again for tissue-building. Thus the internal activity of animals is of two kinds, tissue-destroying and tissue-building; while that of plants seems to be, principally, at least, of one kind, tissue-building. Animals use food for force and repair and growth, and in the mature



animal only for force and repair. Plants use food for force and growth—they never stop growing.

Now, the food of animals is of two kinds, amyloids and albuminoids. The carnivora feed entirely on albuminoids; the herbivora on both amyloids and albuminoids. All this food comes from the vegetable kingdom directly in the case of herbivora, indirectly in the case of carnivora. Animals cannot make organic matter. Now, the tissues of animals are wholly albuminoid. It is obvious, therefore, that for the repair of the tissues the food must be albuminoid. The amyloid food, therefore (and, as we shall see in carnivora, much of the albuminoid), must be used wholly for force. As coal or wood, burned in a steam-engine, changes chemical into mechanical energy, so food, in excess of what is used for repair, is burned up to produce animal activity. Let us trace more accurately the origin of animal force by examples.

10. CARNIVORA.—The food of carnivora is entirely albuminoid. The idea of the older physiologists, in regard to the use of this food, seems to have been as follows: Albuminoid matter is exceedingly unstable; it is matter raised, with much difficulty and against chemical forces, high, and delicately balanced on a pinnacle, in a state of unstable equilibrium, for a brief time, and then rushes down again into the mineral kingdom. The animal tissues, being formed of albuminoid matter, are short-lived; the parts are constantly dying and decomposing; the law of death necessitates the law of reproduction; decomposition necessitates repair, and therefore food for repair. But the force by which repair is effected was for them, and for many physiologists now, underived, innate. But, the doctrine maintained by me in the paper referred to is, that the decomposition of the tissues creates not only the necessity, but also the force, of repair.

Suppose, in the first place, a carnivorous animal uses just enough food to repair the tissues, and no more—say an ounce. Then I say the ounce of tissue decayed not only necessitates the ounce of albuminous food for repair, but the decomposition sets free the force by which the repair is effected. But it will be perhaps objected that the force would all be consumed in repair, and none left for animal activity of all kinds. I answer: it would not all be used up in repair, for, the food being already albuminoid, there is probably little expenditure of force necessary to change it into tissue; while, on the other hand, the force generated by the decomposition of tissue into  $\text{CO}_2$ ,  $\text{H}_2\text{O}$ , and urea, is very great—the ascensive change is small, the descensive change is great. The decomposition of one ounce of albuminous tissue into  $\text{CO}_2$ ,  $\text{H}_2\text{O}$ , and urea, would therefore create force sufficient not only to change one ounce of albuminous matter into tissue, but also leave a considerable amount for animal activities of all kinds. A certain quantity of matter, running down from plane No. 4 to plane No. 2, creates force enough not only to move the same quantity of matter about on plane No. 2, but

also to do much other work besides. It is probable, however, that the wants of animal activity are so immediate and urgent that, under these conditions, much food would be burned for this purpose, and would not reach the tissues, and the tissues would be imperfectly repaired, and would therefore waste.

Take next the carnivorous animal full fed. In this case there can be no doubt that, while a portion of the food goes to repair the tissues, by far the larger portion is consumed in the blood, and passes away partly as  $\text{CO}_2$  and  $\text{H}_2\text{O}$  through the lungs, and partly as urea through the kidneys. This part is used, and can be of use only, to create force. The food of carnivora, therefore, goes partly to tissue-building, and partly to create heat and force. The force of carnivorous animals is derived partly from decomposing tissues and partly from food-excess consumed in the blood.

11. HERBIVORA.—The food of herbivora and of man is mixed—partly albuminoid and partly amyloid. In man, doubtless, the albuminoids are usually in excess of what is required for tissue-building; but in herbivora, probably, the albuminoids are not in excess of the requirements of the decomposing tissues. In this case, therefore, the whole of the albuminoids is used for tissue-making, and the whole of the amyloids for force-making. In this class, therefore, these two classes of food may be called tissue-food and force-food. The force of these animals, therefore, is derived partly from the decomposition of the tissues, but principally from the decomposition and combustion of the amyloids and fats.

Some physiologists speak of the amyloid and fat food as being burned to keep up the animal heat; but it is evident that the prime object in the body, as in the steam-engine, is not heat, but force. Heat is a mere condition and perhaps a necessary concomitant of the change, but evidently not the prime object. In tropical regions the heat is not wanted. In the steam-engine, chemical energy is first changed into heat and heat into mechanical energy; in the body the change is, probably, much of it direct and not through the intermediation of heat.

12. We see at once, from the above, why it is that plants cannot feed on elements, viz., because their food must be decomposed in order to create the organic matter out of which all organisms are built. This elevation of matter, which takes place in the green leaves of plants, is the starting-point of life; upon it alone is based the possibility of the existence of the organic kingdom. The running down of the matter there raised determines the vital phenomena of germination of pale plants, and even of some of the vital phenomena of green plants, and all the vital phenomena of the animal kingdom. The stability of chemical compounds, usable as food, is such that a peculiar contrivance and peculiar conditions found only in the green leaves of plants are necessary for their decomposition. We see, therefore, also, why animals as well as pale plants cannot feed on mineral matter.

We easily see also why the animal activity of carnivora is greater than that of herbivora, for the amount of force necessary for the assimilation of their albuminoid food is small, and therefore a larger amount is left over for animal activity. Their food is already on plane No. 4; assimilation, therefore, is little more than a *shifting* on the plane No. 4 from a liquid to a solid condition—from liquid albuminoid of the blood to solid albuminoid of the tissues.

We see also why the internal activity of plants may conceivably be only of one kind; for, drawing their force from the sun, tissue-making is not necessarily dependent on tissue-decay. While, on the other hand, the internal activity of animals must be of two kinds, decay and repair; for animals always draw a portion of their force, and starving animals the whole of their force, from decaying tissue.

13. There are several general thoughts suggested by this subject, which I wish to present in conclusion:

a. We have said there are four planes of matter raised one above the other: 1. Elements; 2. Chemical compounds; 3. Vegetables; 4. Animals. Now, there are also four planes of force similarly related to each other, viz., physical force, chemical force, vitality, and will.

4. *Animals.*

3. *Plants.*

2. *Chemical compounds.*

1. *Elements.*

On the first plane of matter operates physical force only; for chemical force immediately raises matter into the second plane. On the second plane operates, in addition to physical, also chemical force. On the third plane operates, in addition to physical and chemical, also vital force. On the fourth plane, in addition to physical, chemical, and vital, also the force characteristic of animals, viz., will.<sup>1</sup> With each elevation there is a peculiar force added to the already existing, and a peculiar group of phenomena is the result. As matter only rises step by step from plane to plane, and never two steps at a time, so also force, in its transformation into higher forms of force, rises only step by step. Physical force does not become vital except through chemical force, and chemical force does not become will except through vital force.

Again, we have compared the various grades of matter, not to a gradually rising inclined plane, but to successive planes raised one above the other. There are, no doubt, some intermediate conditions; but, as a broad, general fact, the changes from plane to plane are sudden. Now, the same is true also of the forces operating on these planes—of the different grades of force, and their corresponding groups of phenomena. The change from one grade to another, as

<sup>1</sup> I might add still another plane and another force, viz., the human plane, on which operate, in addition to all the lower forces, also free-will and reason. I do not speak of these, only because they lie beyond the present ken of inductive science.

from physical to chemical, or from chemical to vital, is not, as far as we can see, by sliding scale, but suddenly. The groups of phenomena which we call physical, chemical, vital, animal, rational, and moral, do not merge into each other by insensible gradations. In the ascension scale in the evolution of the higher forces there are places of rapid paroxysmal change.

*b.* Vital force is transformed into physical and chemical forces; but it is not on that account identical with physical and chemical force, and therefore we ought not, as some would have us, discard the term vital force. There are two opposite errors on this subject: one is the old error of regarding vital force as something innate, underived, having no relation to the other forces of Nature; the other is the new error of regarding the forces of the living body as nothing but ordinary physical and chemical forces, and therefore insisting that the use of the term vital force is absurd and injurious to science. The old error is still prevalent in the popular mind, and still haunts the minds of many physiologists; the new error is apparently a revelation from the other, and is therefore common among the most advanced scientific minds. There are many of the best scientists who ridicule the use of the term vital force, or vitality, as a remnant of superstition; and yet the same men use the words gravity, magnetic force, chemical force, physical force, etc. Vital force is not underived—is not unrelated to other forces—is, in fact, correlated with them; but it is nevertheless a distinct form of force, far more distinct than any other form, unless it be still higher forms, and therefore better entitled to a distinct name than any lower form. Each form of force gives rise to a peculiar group of phenomena, and the study of these to a peculiar department of science. Now, the group of phenomena called vital is more peculiar, and different from other groups, than these are from each other; and the science of physiology is a more distinct department than either physics or chemistry; and therefore the form of force which determines these phenomena is more distinct, and better entitled to a distinct name, than either physical or chemical forces. De Candolle, in a recent paper,<sup>1</sup> suggests the term vital movement instead of vital force; but can we conceive of movement without force? And, if the movement is peculiar, so also is the form of force.

*c.* Vital is transformed physical and chemical forces; true, but the necessary and very peculiar condition of this transformation is the previous existence then and there of living matter. There is something so wonderful in this peculiarity of vital force that I must dwell on it a little.

Elements brought in contact with each other under certain physical conditions—perhaps heat or electricity—unite and rise into the second plane, i. e., of chemical compounds; so also several elements, C, H, O and N, etc., brought in contact with each other under certain

<sup>1</sup> *Archives des Sciences*, vol. xlv., p. 345, December, 1872

physical or chemical conditions, such as light, nascency, etc., unite and rise into plane No. 3, i. e., form organic matter. In both cases there is chemical union under certain physical conditions; but in the latter there is one unique condition, viz., the previous existence then and there of organic matter, under the guidance of which apparently the transformation of matter takes place. In a word, organic matter is necessary to produce organic matter; there is here a law of like producing like—there is an assimilation of matter.

Again, physical force changes into other forms of physical force, or into chemical force, under certain physical conditions; so also physical and chemical forces are changed into vital force under certain physical conditions. But, in addition, there is one altogether unique condition of the latter change, viz., the previous existence then and there of vital force. Here, again, like produces like—here, again, there is assimilation of force.

This law of like producing like—this law of assimilation of matter and force—runs throughout all vital phenomena, runs to the minutest details. It is a universal law of generation, and determines the existence of species; it is the law of formation of organic matter and organic force; it determines all the varieties of organic matter which we call tissues and organs, and all the varieties of organic force which we call functions. The same nutrient pabulum, endowed with the same properties and powers, carried to all parts of a complex organism by this wonderful law of like producing like, is changed into the most various forms and endowed with the most various powers. There are certainly limits and exceptions to this law, however; otherwise differentiation of tissues, organs, and functions, could not take place in embryonic development; but the limits and exceptions are themselves subject to a law even more wonderful than the law of like producing like itself, viz., the law of evolution. There is in all organic nature, whether organic kingdom, organic individual, or organic tissues, a law of variation, strongest in the early stages, limited very strictly by another law—the law of inheritance, of like producing like.

*d.* We have seen that all development takes place at the expense of decay—all elevation of one thing, in one place, at the expense of corresponding running down of something else in another place. Force is only transferred and transformed. The plant draws its force from the sun, and therefore what the plant gains the sun loses. Animals draw from plants, and therefore what the animal kingdom gains the vegetable kingdom loses. Again, an egg, a seed, or a chrysalis, developing to a higher condition, and yet taking nothing *ab extra*, must lose weight. Some part must run down, in order that the remainder should be raised to a higher condition. The amount of evolution is measured by the loss of weight. By the law of conservation of force, it is inconceivable that it should be otherwise. Evidently, therefore, in the universe, evolution of one part must be at the ex-

pense of some other part. The evolution or development of the whole cosmos—of the whole universe of matter—as a unit, according to the doctrine of conservation of force, is inconceivable. It could only take place by a constant increase of the whole sum of energy, i. e., by a constant influx of divine energy.

e. Finally, as organic matter is so much matter taken from the common fund of matter of earth and air, embodied for a brief space, to be again by death and decomposition returned to that common fund, so also it would seem that the organic forces of the living bodies of plants and animals may be regarded as so much force drawn from the common fund of physical and chemical forces, to be again all refunded by death and decomposition. Yes, by decomposition; we can understand this. But death! can we detect any thing returned by simple death? What is the nature of the difference between the living organism and a dead organism? We can detect none, physical or chemical. All the physical and chemical forces withdrawn from the common fund of Nature, and embodied in the living organism, seem to be still embodied in the dead until little by little it is returned by decomposition. Yet the difference is immense, is inconceivably great. What is the nature of this difference expressed in the formula of material science? What is it that is gone, and whither is it gone? There is something here which science cannot yet understand. Yet it is just this loss which takes place in death, and before decomposition, which is in the highest sense vital force.

Let no one from the above views, or from similar views expressed by others, draw hasty conclusions in favor of a pure materialism. Force and matter, or spirit and matter, or God and Nature, these are the opposite poles of philosophy—they are the opposite poles of thought. There is no clear thinking without them. Not only religion and virtue, but science and philosophy, cannot even exist without them. The belief in spirit, like the belief in matter, rests on its own basis of phenomena. The true domain of philosophy is to reconcile these with each other.



## HEREDITY AND RACE-IMPROVEMENT.

By FERNAND PAPIILLON.

TRANSLATED FROM THE FRENCH BY J. FITZGERALD, A. M.

### II.

SO far we have been giving the historical refutation. A more direct and scientific refutation will prove still more decisive and instructive. Having shown that heredity does not exert an exclusive and continuous influence, we must now indicate the causes which act simultaneously with it and in a contrary direction. We have to de-



monstrate the constant and powerful influence of those forces which, as we have said, tend to modify, transform, and complicate man's thoughts, feelings, passions, manners, customs.

The special aim of education is to transmit to the child the sum of those habits to which he is to conform the course of his life, and of those branches of knowledge which are indispensable for him in the pursuit of his calling; and it must begin by developing in the pupil the faculties which will enable him to make these habits and this knowledge his own. It teaches the child to speak, to move about, to look, to use his senses, to hear, to understand, to judge, to love. But now the influence of education, opposed as it is to that of heredity, is so great, that in most cases it is of itself alone capable of producing a moral and psychological likeness between children and parents. If heredity determined irresistibly and infallibly in the descendants the essential characters of their ancestors' personality, education would be superfluous. When once it is admitted that education, a long, watchful, laborious training, is indispensable in order to call forth and perfect in the child the development of aptitudes and of mental qualities, we must conclude that heredity acts only a secondary part in the wonderful genesis of the moral individual. The argument is unassailable. That hereditary influences make their mark in predispositions, in fixed tendencies, it were unscientific to deny; but yet it would be inexact to pretend that they implicitly contain the future states of the psychical being, and determine its evolution.

There is nothing more complex than education, nor must we think here of studying its general economy, which has been the theme of so many books. The importance which is generally attributed to works on pedagogy is of itself a protest against the abuse of hereditarian theories. Some fresh details as to one of the chief agencies in education, viz., the instinct of imitation, and the part it plays in the development of individuals and of races, will suffice to demonstrate the energy of certain influences which have nothing to do with heredity.

An accomplished English historian, Bagehot, recently published some excellent observations, which go to show what great influence is exerted in the formation of customs and of tastes, and also how their periodic revolutions are explained, by the unconscious imitation of a favorite character or type, and by the general favor accorded to the same. According to him, a national character is only a local character which has been favored by fortune, precisely as a national language is only the definitive extension of a local dialect. There is nothing more undoubted than the force of this tendency to imitation. It is in virtue of this that certain processes in manufacture, art, literature, manners, discovered under peculiar circumstances, attain a general ascendancy, and are rapidly imposed, first upon the docile and unthinking multitude, and then on those who possess all the means of inquiry and resistance. Here it may be observed that the *élite* are almost always

constrained to follow the tastes and the judgments of the masses, under penalty of being ignored or contemned. A writer devises a style which the public receive with enthusiasm: he has struck a vein. He accustoms those who read his books, or who witness his plays, to this style, be it good or bad, and the result is that, for some time, all authors are compelled more or less to imitate the fortunate innovator, if they wish to succeed. Hence, though one were not led to imitate, by instinct or by nature, still he would do so from necessity or from self-interest. The founder of the London *Times* was once asked how he contrived to have all the articles in that journal appear as though written by one hand. "Oh," said he, "there is always one editor who is superior to all the rest, and they imitate him."

The history of religions from beginning to end is full of facts showing how men are guided, not by arguments but by exemplars, and exhibiting the tendency they have to reproduce what they have seen or heard, and to regulate their lives according to the bright and triumphant examples that stand before their eyes. Many victories, esteemed by apostles to be the effects of persuasion, are rather to be attributed to that recondite influence which leads men irresistibly to imitate their fellows. And does not this same agency of imitation appear in the body politic, transforming little by little, but yet radically, the habits, the opinions, and even the beliefs of men? Nothing is easier, than, for a man who has acquired an influence over the populace, to bring them over to his own sentiments, ideas, and chimeras. And the observation is confirmed by daily experience in the education of children. In a school we often find the external characteristics—the tone, the gait, the games, changing from year to year. The reason of this is that some dominant spirits—two or three pupils who used to have an ascendancy over the rest, have left; others are now in their place, and every thing wears a different face. As the models change, so do the copies. The pupils no longer applaud or jeer at the same things as before.

This instinct of imitation is specially developed in persons of defective education or civilization. Savages copy quicker and better than Europeans. Like children, they have a natural faculty for mimicry, and cannot refrain from imitating every thing they see. There is in their minds nothing to offset this tendency to imitation. Every well-instructed man has within himself a considerable reserve of ideas upon which to fall back; this resource is wanting in the savage and in the child: they live in all the occurrences which take place before them; their life is bound up in what they see and hear; they are the playthings of external influences. In civilized nations persons without culture are in the like situation. Send a chambermaid and a philosopher into a country, the language of which neither of them is acquainted with, and it is likely that the chambermaid will learn it before the philosopher. He has something else to do: he can live with his

own thoughts ; as for her, if she cannot talk, she is undone. The instinct of imitation is in an inverse ratio to the power of mental abstraction.

From these details it will be seen that this strong instinctive force of imitation, which plays so important a part in the education of individuals and of races, is a very different thing from heredity. It may and it does act in concert with hereditary impulsions ; but far more frequently it works independently and even in a direction counter to them. And the same is to be said of another force—a more determined rival still, and a more puissant antagonist of heredity, viz., personality, whose functions we have next to consider.

The individual personality of the soul, which is preëminently the instrument of free inventiveness and the unfailing spring of the innovative faculty, might, in contrast with heredity, be called spontaneity.<sup>1</sup> To give a notion of the power of spontaneity, as compared with that of heredity, we might draw up lists exhibiting cases in which the manifestation of various passions or talents does not come from ancestry, and in which the individual is born different from his parentage, or distinguishes himself from them by the reaction of his own will. Such lists would be endless ; for, the opinion of the partisans of absolute heredity to the contrary notwithstanding, spontaneity and personal activity are the rule in the development of the mind. In short (and this is the main point), heredity has its root in spontaneity ; for, after all, those aptitudes, those qualities, which parents transmit to their children, must necessarily have originated, at some time, from the spontaneous action of a more or less independent will. We hear of idiots, and of hysterical and epileptical subjects, or, on the other hand, of painters, musicians, and poets, who derive from their parentage the sinister or the beneficent activities which characterize them. True enough ; but the question for us is, Whence did the parents themselves derive this activity ? In taking a retrospective view of the *ascendants*, we must reach the point where spontaneity is preëminent ; and this preëminence is all the less questionable in proportion as it reappears in the descendants. The effects of heredity appear and disappear ; at first, they overmaster spontaneity, suspending its influence ; then they are exhausted, and spontaneity again reclaims its rights. Thus spontaneity is a continuous, persisting force, while heredity is intermittent and transitory. Human nature, considered in its progress from age to age, is a succession of independent minds, all the more independent in proportion as they have less need of the concurrence of mechanical or organic powers in willing and acting. Where they require such concurrence, a portion of their innate independence is surrendered to the blind influences of heredity. And yet, even as regards the origin of æsthetic aptitudes, spontaneity is the stronger of the two.

<sup>1</sup> Spontaneous. *Produced without being planted.*—(Webster.) *Native, innate.*

In studying the history of illustrious men, how often do we find brilliant imagination and extraordinary capacity for art, poetry, and literary composition, which are by no means the result of heredity. We have not far to go for instances of this. Lamartine, Alfred de Musset, Meyerbeer, Ingres, Delacroix, Mérimée, displayed talents for which they were in no wise indebted to their parentage. The history of men of science exhibits the part played by heredity still further cut down. We are told of families of *savants*. How many of these might be enumerated? A dozen at the most. On the other hand, how many illustrious *savants* there are, among whose ascendants are found only people of very common stamp, or else distinguished for talents of a very different order from those which characterize the man of science! What hereditary influences fashioned a Cuvier, a Biot, a Fresnel, a Gay-Lussac, an Ampère, a Blainville? It is plain that in these instances spontaneity and education enacted the chief part. Nor does the history of authors agree any better with the pretensions made by the thorough partisans of heredity.

It is especially among philosophers that spontaneity appears to be supreme. Our authors present no lists of philosophers who have inherited from their ancestors the talent for speculation. Here we have a series of facts which make against heredity; these its advocates say nothing about, nor indeed are they made sufficient account of by either party. Metaphysicians, precisely because in them the mental element alone is active, are exempt from all the influences of heredity. In proportion as the characters it tends to transmit are less of a physiological and more of a psychological nature, the less is the influence of heredity. But there is nothing more purely psychological, or more free from sense-elements and mechanical factors, than the mind of the speculative philosopher. In point of fact, the great metaphysicians had no progenitors, nor did they leave any posterity. The philosophic genius has ever been absolutely individual, inalienable, and intransmissible. There is not a single great thinker, in whose line, whether ascending or descending, we discover either the promise or the perpetuation of the high capacities which made him illustrious. Descartes and Newton, Leibnitz and Spinoza, Diderot and Hume, Kant and Maine de Biran, Cousin and Jouffroy, had neither ancestors nor posterity.

Such is spontaneity. To form a precise idea of the part it plays, we should have to determine, in a general way, and also in relation to temperament, education, social and other conditions, etc., the genesis and development of those faculties by which a given man of superior power is distinguished from his progenitors; we must group together and classify the characteristic elements which make up the very essence of the personality and individuality—those marvelous elements of free initiative and of total independence which stamp a man as a genius. It would then be seen that most commonly superior abilities

are so native to those who display them, so deep seated and endowed with a life of their own, that education and training, instead of calling them forth, serve rather to check their development. In a man of genius we should discern self-reliant precocity, a passion for enterprise, a strong belief in his mission, a pride lifting him above sect-prejudice or party ambitions, and attaching him exclusively to the object of his meditations, for which alone he values life. Even when temporal necessities compel him to take part in the transactions of men, the world is for him only a peopled wilderness, where his soul lives in solitude.

The materials for such a study exist in part; they are to be found in biographies written during the last two hundred years, by the secretaries of the great academies, and in the autobiographic memoirs left by several illustrious men. An ingenious and learned Russian writer, Wechniakof, has lately published sundry works, in which he considers, from this point of view, the anthropological and sociological peculiarities which have had an influence in the individual development of original geniuses. Unfortunately, these opuscles do not form a complete treatise, and yet a treatise on spontaneity would be a very curious and very useful work.

The aggregate of all the causes of diversity, heterogeneity, and innovation, which in man act in opposition to the principles of simplicity, homogeneity, and conservation, we may designate by one name, viz., evolution or progress. Regarded within the limits of positive observation, blind Nature has been ever the same. It is to-day, on the whole, what it was in Homer's time: the same sky, oceans, mountains, forests, flowers. Man, on the other hand, is ever undergoing transformation. Generations succeed one another, but are unlike. They are in a state of constant and rapid metamorphosis in their faiths, their knowledge, their arts, their wants. Nations, like individuals, grow up and decay. But the face of Nature is unchanged: as Byron says of Greece:

“ Yet are thy skies as blue, thy crags as wild ;  
 Sweet are thy groves, and verdant are thy fields,  
 Thine olive ripe as when Minerva smiled,  
 And still his honeyed wealth Hymettus yields ;  
 There the blithe bee his fragrant fortress builds,  
 The free-born wanderer of thy mountain air ;  
 Apollo still thy long, long summer gilds,  
 Still in his beam Mendeli's marbles glare ;  
 Art, glory, freedom fail, but Nature still is fair.”

We might multiply *ad infinitum* these historic contrasts between the immutability of the universal fatalism which reigns in Nature, and the incessant movement of liberty and invention in man, together with the ceaseless striving of the soul to free itself from the grip of Fate. History is but the record of what has resulted during ages

from this movement, from this striving. It is a protracted drama, where the good genius of liberty contests the throne with the evil genius of brute force, and where, under the eye of God, and with his assistance, is won, slowly and laboriously, the victory of mind, which searches, discovers, invents, creates, loves, adores!

### III.

In the first part of this essay we established the facts of heredity, and showed the part it plays in reproducing physiological and psychological characteristics. In the second we pointed out and examined the causes which run counter to the more or less tyrannical impulsions of Nature, and to mechanical necessities. We have now to state some practical conclusions as to the use that may be made of this knowledge in perfecting the race.

The heroic combatants of Homer's epic invoked the names of their fathers and ancestors, and were proud of their noble blood. It was a high instinct, and they who can justly boast of their forefathers will always be in a position to earn for themselves the respect of their children. In short, the phenomena of heredity authorize the belief that parents of well-constituted body and mind are most likely to transmit to their posterity their own likeness.

What measures are to be taken, then, to bring about happy alliances, such as will produce offspring of high excellence in a physical and moral point of view? This is a very delicate question, and we can give only a summary reply to it, based chiefly on an unpublished work by the eminent surgeon, M. Sédillot, who devotes the leisure time of his honorable retirement to studying the means of perfecting the race. First of all, M. Sédillot thinks that we may obtain valuable information as to an individual's real value by consulting his genealogy: the history of his ascendants for four or five generations, with special reference to intellect, morality, vigor, health, longevity, social status, virtually contains a portion of his own history. Long before Gall the fact was established (nor was it overturned by Gall's exaggerations) that the form of the head is, in some measure, an index of a man's mental calibre. From the remotest antiquity, the popular mind has observed the relation which subsists between great size of head and superior abilities; and language is full of expressions which witness to the correctness of this relation. Pericles excited the astonishment of the Athenians by the extraordinary volume of his head. Cromwell, Descartes, Leibnitz, Voltaire, Byron, Goethe, Talleyrand, Napoleon, Cuvier, etc., had very large heads. Cuvier's brain weighed 1,829 grammes, the average weight of Europeans' brains being, according to Broca, from 1,350 to 1,400 grammes. M. Sédillot regrets that we do not possess measurements of the various cranial dimensions of men distinguished for certain capacities, so that we might ascertain the important relations which subsist between these dimensions and



these capacities ; and he expresses the wish that such measurements should be taken. But at least we know, in a general way, what characters and what cranial dimensions correspond with the various degrees of cerebral activity. Most anthropologists hold that the man whose head has not an horizontal circumference of 50 centimetres (19.685 inches) is almost inevitably a person of only mediocre ability, and that the one in whom this circumference attains or surpasses 58 centimetres (22.8346 inches) is likely to be a very superior man. Instances are cited, it is true, of celebrated personages with small heads ; but in such case the individuals gained distinction in some very narrow specialty. It must not be forgotten that these dimensions constitute but one of the external indices which enable us to determine approximately the intellectual value of an individual. We have also to take account of the general form and relative proportions of the various regions of the cranium, i. e., of that harmony which is called beauty. An easy means, according to M. Sédillot, of studying the conformation of the head, is by taking a side or profile view of it, a little back of the forehead. One then instantly perceives the ratio between the height and breadth of the forehead and temples and the face, and a clear perception is got of the relative proportions of the anterior or frontal, and the posterior or occipital contours of the head. The individual who has the superciliary arches prominent, the temples bare, nearly vertical and high, with broad, high forehead, and features expressive neither of an unbalanced nor of a torpid mind, may in general be regarded as a truly human type, and as possessed of a mind that is fitted to do honor to the race. The story goes, that once a certain Englishman sent his groom to the ale-house in search of his friend Shakespeare. "How shall I know him?" quoth the groom. "The easiest thing in the world," replied his master; "everybody, more or less, resembles some animal; but, when you lay eyes on Shakespeare, you will at once say, 'There is a man!'" Man in the fullness of his harmonious beauty, such is the ideal toward which all the efforts of our present imperfect humanity ought to be directed, and it is full time that we should strive, by a wise use of the principle of heredity, i. e., by healthy procreation, to develop a human race in which the last traces of animality shall have disappeared, and in which the *Man* shall be less rare.

What is it that constitutes the superiority of the English aristocracy? Their constant study to endow their descendants with the best bodily, intellectual, and moral qualities. The Englishman does not marry from caprice or from passion; he marries under the conditions which are best fitted to insure the welfare of his children, for he knows that on their welfare his own happiness, his honor, and his name depend. The respect shown to young Englishwomen, the honorable liberty they enjoy, the secondary importance that is attached to their fortune, and the stress that is laid on their personal worth, are all so many

causes increasing among that people the number of happy marriages, and consequently giving vigor to the population. This is one of the grand secrets of race-improvement by heredity. Instead of looking for wealth, men must look for beauty, character, and virtue. So long as they persist in forming alliances with women of feeble constitution, or lacking essential qualifications, the race will decline and degenerate. And, of course, the same deplorable consequences follow from the marriage of noble and well-organized women with men of inferior type. Fortunately, the tact and the instinctive dignity of women, and their natural liking for what is exalted, usually prevent their descending to debasing or dangerous alliances, and nearly always guard them against ill-assorted matches. "In place of giving way to sympathetic emotions," says M. Sédillot, "which disorder the judgment, let one put himself the question, on seeing a person that pleases him, if he wants to have sons and daughters of that same type; and it is curious to note how often the reply will be in the negative. It were unreasonable, no doubt, to forego present advantage for the sake of some uncertain advantage in the future; still, wisdom requires us to bring the two into harmony, and to remember how swiftly time passes away, and how little is the value of the passing hour, as compared with the hopes and the enjoyments of the future." M. Sédillot adds that, in ordinary times, hygiene, the moral evidence of the advantages of health and intelligence, would suffice for the regeneration of a people. France, unfortunately, has need of stronger and more efficacious agencies; she must go back to the very fountain-head of regeneration and of life, that is to say, must discover the speediest means of insuring to the coming generations a future of virtue and mettle. In other times it may have appeared difficult or ill-advised to import, into questions touching the reproduction of man, figures and estimates not unlike those employed in zootechny, where selection has long been practised. But now such scruples must give way before the dictates of necessity, which tells us in the most unmistakable way that we cannot afford to commit one blunder more.

Here we have to point out the means of staying or of reducing as far as possible the fatal heredity of disease, which is so powerful an obstacle to the improvement of the race. The preventive or prophylactic agencies which are to be employed to counteract the evolution of disease-germs depend, of course, on the nature of these latter. A consumptive mother must not suckle her infant; she ought to intrust it to the care of a good nurse. Those whose parents were affected with chest-diseases thrive but ill on an excessively animal diet: a regimen of *white meats* and light foods is best suited for them. As regards occupation, they should carefully avoid all such as would expose them to inhale dust, or to undergo alternations of heat and cold, or to use the voice habitually. Residence by the sea-side, in the south, and in localities where consumption is of rare occurrence,

is the best prophylactic against this fearful disease. Individuals predisposed to scrofula require pure air, substantial tonic diet, and an atmosphere like that on the sea-coast of Northwestern Europe. Those who are threatened with gout or gravel must oblige themselves to the strictest temperance and take abundant exercise. Regularity and uniformity of life are the rule for those predisposed to cancer. Persons who reckon epileptics among their ascendants require the utmost care. All their functions must be tranquillized; they must allow themselves no excesses; must avoid fatigue; must guard against emotional excitement—in a word, they must be always surrounded with tranquillizing influences. Those predisposed to insanity are to be treated in a similar manner, that is to say, with great gentleness; and their passions are to be stilled. The course of life best suited to them is one which does not call for much intellectual activity, and which holds out no visions of fame or fortune. Preventing or checking in the individuals themselves the development of disease-germs is, however, but a secondary consideration; the chief point is, to prevent the migration of these germs into new generations. But, to attain this result, we must not only multiply and facilitate marriages which shall be in conformity with hygienic and moral laws, we have furthermore to discourage alliances the fruits of which can only be of blighted constitution in body and soul. Physicians ought to use all their influence to prevent the intermarriage of persons evidently predisposed to the various forms of neurosis, to tubercle, scrofula, etc. When the ascendants of one of the parties are hereditarily of a morbid constitution, the physician should at least insist on the importance of having the other party perfectly healthy, possessed of great vigor, and, above all, of a temperament the reverse of that of his or her partner. In this way the danger of hereditary taint is diminished, though it were better not to incur such danger at all. But this is a point of so delicate a nature that we cannot dwell upon it here. We must, however, say something about consanguineous marriages, a subject which has given rise to much warm controversy during the past few years. Some physicians, and among them Broca and Bertillon, hold that races which are least mixed, which are purest, are better fitted than crossed races to withstand the causes of degeneracy. According to them, the evil consequences charged on consanguinity are the result of very different agencies, especially the hereditary affections of the ascendants. Trousseau and Boudin, on the other hand, say that marriages between individuals of the same stock oftentimes yield unhealthy fruits—lunatics and idiots. The balance would appear to have been struck in favor of the first opinion. It was but the other day, that Auguste Voisin, in making inquiries of the relatives of more than 1,500 patients in the Bicêtre and the Salpêtrière, found that in none of these cases could the disease be attributed to consanguinity. If the latter had been so infallible a cause of degeneracy,

its effects would have been seen in that large number of madmen and idiots.

Although theorizers have exaggerated the influence of heredity, it cannot be denied that it plays a part in the genesis of temperament and character, and here we have a warrant for the employment of every means that will favor the transmission of the most desirable aptitudes. In ancient Rome, women of the highest distinction, who were respected by all, imported into another family, with their husbands' consent, their superiority of blood. Quintus Hortensius, the friend and admirer of Cato, having failed to win his daughter Portia, asked for his wife Marcia, and Cato gave her to him. The grossness of such customs shocks our finer sense, but its explanation is to be found in the anxiety of a Roman head of a family to insure for his descendants the highest grade of masculine vigor, and the most solid virtues.

Under the old constitution of society in France, the tenure of high offices and trusts, and the following of some special profession by one family from generation to generation, had their rise and bases in the unconscious observation that aptitudes are hereditary; and M. Sédillot regrets that the revolutions of modern society have done away with this wholesome tradition, which, in every grade of the social scale, morally constrained the son to follow in his father's steps. This point must not be overlooked by races which care for self-improvement.

Another point for such races to bear in mind, and one of readier application, is the necessity of a sound and enlightened system of education. On this topic, those who have the future of France at heart, have but one opinion, viz., that the coming generations must be invigorated by giving more prominence to bodily exercise, and by exempting children from employments injurious to health. They have no thought of interfering with classical studies or the humanities, which will continue to be the chief element in moral culture; the only question is, whether the young could not acquire the treasures of Latinity and Hellenism in less time, and bestow some little study on matters of modern interest. There are sundry branches in which they now obtain no instruction, but which they might study much to the advantage of their intellectual development. This is not the place to enforce this argument; but it does seem unquestionable that, by means of a thorough system of education, proceeding on new principles, we might be able, if not exactly to change the whole character of a people, as Leibnitz thought, at least to do away with most of the influences which, for want of suitable training, cause them to fall into decay.

The conviction that it is possible to counteract the dangerous impulses of heredity and to triumph over the tyrannies of Fate—at least to acquire a moral superiority over them—is a most wholesome one to spread abroad and to bring into acceptance. A strong will is in itself a power. Even though it were not so easy a thing as it is, to prevail

over the blind forces of Nature, simply by the overmastering power of a resolute and sagacious will, there would still exist abundant grounds for believing that man has the power of modifying and amending his own conduct; that he is not the plaything of inflexible Destiny; and that he may not give way, without resistance or remorse, to his evil instincts. Let us believe in heredity, in so far as it may be made a means of improvement and of free perfectionment. But let us withhold our assent when there is claimed for it a despotic power so absolute as it would be madness to resist. Education has not only to improve the race, but also to give men a desire for improvement, by showing them that it is possible. In alliance with a judicious cultivation of desirable hereditary tendencies, education overmasters noxious proclivities and regenerates the race.

We must not, however, attribute to education an exaggerated importance, nor imagine that by itself alone it can call forth preëminent ability. Its influence, like that of heredity, is limited. Genius, which is the most perfect expression of mind, considered as a free creative force, is controlled by neither. It is a mighty tree whose fruits give sustenance to generations, and the conditions of whose growth are such that we can no more foresee or determine its appearing than we can prescribe rules for its behavior afterward, or estimate its fruitfulness. Fortunately, geniuses are not indispensable, and, in proportion as the national average rises, the less need is there for them. But the general average rises of necessity when all the citizens are animated with the one desire of improvement. Hereditary cultivation, proceeding by means of a rigid selection of the influences which tend to improve the race, may be confidently commended to those nations who are ambitious of holding the first rank in the world.—*Revue des Deux Mondes*.

---

## HÄCKEL'S MONERS.

BY AIME SCHNEIDER.

THE moners are the simplest organisms we know of—we might even say, the simplest that can exist. In them, life is exhibited under the form that is best fitted to give us an idea of its essential characters, stripped of all secondary attributes. The first moner was discovered by the celebrated Prof. Häckel, of Jena, in 1864, and the number has gone on steadily increasing ever since. These discoveries have made a great stir in the scientific world, owing to their bearing on our theories of organization.

The moner which best typifies the entire class is the *Protomyxa aurantiaca*. This little creature, hardly visible to the naked eye, and, at most, as big as a small pin-head, is of a fine orange-red color, con-

sists of a perfectly homogeneous and transparent mass of jelly, and offers the paradox of *an organism without organs*. Nor is this absence of organs merely apparent, or owing to the imperfection of our magnifying-glasses; it is real, and every thing about these little creatures goes to prove their perfect simplicity of structure. This gelatinous, homogeneous, contractile substance has been called *sarcode*, and also, but improperly, *animal protoplasm*.

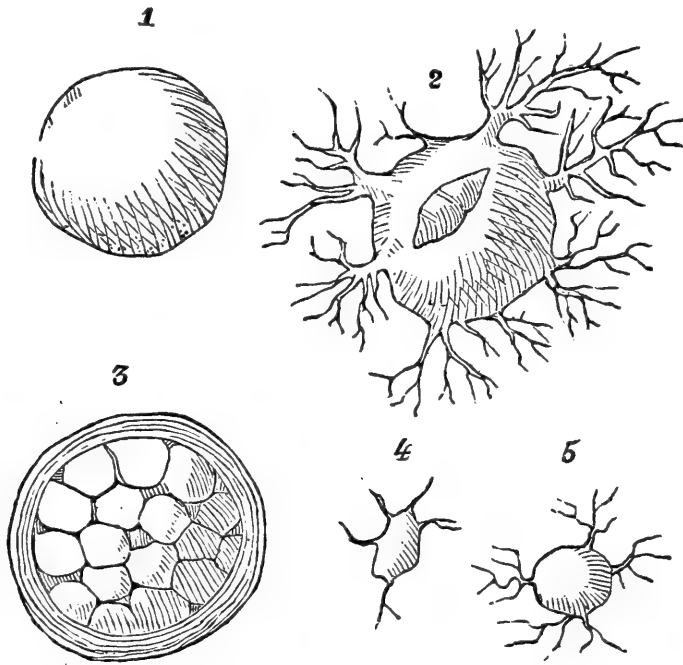

HISTORY OF THE PROTOMYXA AURANTIACA, ACCORDING TO HÄCKEL.

1. The moner in a state of repose.
2. The same sending forth its pseudopodes and embedding a foreign body in itself.
3. The same in process of reproduction, after having exuded its envelope, and split up into a number of spherical masses.
4. A young moner set free after the bursting of the envelope.
5. The same in a more advanced stage, with its pseudopodes.

In repose, the moner is nearly spherical, and gives no sign of life. But soon this little ball flattens itself out, its mass expands in various directions, and these expansions, which have received the name of *false feet*, or *pseudopodes*, keep up a continual movement of protrusion and retraction. Sometimes the moner *flows* all in one direction, and this is its way of moving from place to place. When, in the course of this slow progress over the calcareous slime of the sea-bottom, the moner falls in with one of those microscopic organisms called diatoms, it embeds it in its own body; the alimentary substances contained in the diatom are dissolved and assimilated, and the indigestible portions are left behind as the creature moves along. Thus, we have the curious phenomenon of a creature which feeds without mouth, without stomach, without apparatus of any kind, simply by incorporating into itself, as it moves, prey of every kind. In taking food, the animal appears to be passive, its seizing on its prey being a mere incident of its moving about.



In this way, the moner attains by degrees a certain size, and then stops growing and moving. It then becomes a little ball, exudes from its surface a colorless, homogeneous matter which hardens, forming a protecting envelope for the inclosed mass. Then, a very singular phenomenon occurs: by an act entirely spontaneous, the inclosed mass breaks up into a certain number of parts, which soon become independent, constituting so many little spherical masses lying side by side within the common envelope. The original moner then exists no more; it has reproduced itself by dividing itself up, without any intermediary, into these new individuals, its progeny. Each young moner is a determinate part of the mother-animal, and, leaving out of consideration what she exuded to form the envelope, all the rest of her substance is exempted from death, and is now to begin a new life, which in turn will pass through the series of transformations already described. The envelope will soon break up and set at liberty the young moners, which, from the first, resemble the mother-animal.

At the grade of extreme simplification of life presented to us in the moner, we have organization reduced to pure sarcode, and life manifesting itself by nutrition, reproduction, and contractility, each reduced to its barely essential function—nutrition reduced to mere assimilation, reproduction to a spontaneous fission into a group of young (fissiparity), and contractility to the slow, diffusive movements of the pseudopodes.

Moners are mostly inhabitants of the sea. Some of them live at inconsiderable depths; but there is one, the *Bathybius Hückelii*, which lives at the enormous depth of 12,000 feet, and sometimes even of more than 24,000 feet. There is only one fresh-water moner.

Many naturalists rank moners among animals, classing them as rhizopods. Hæckel, who discovered them, regards them as the representatives of an entire category of beings intermediate between animals and plants, the *protista*, so called from *protos* (first), because, according to this author, they are the first representative of terrestrial life, from which all other forms of life are developed, on the modern theories of Darwinism.—*La Nature*.

---

## A NEW METHOD WITH THE BRAIN.<sup>1</sup>

BY PROFESSOR FERRIER.

ALL are agreed that it is with the brain that we feel, and think, and will; but whether there are certain parts of the brain devoted to particular manifestations, is a subject on which we have only imperfect speculations or data too insufficient for the formation of a scientific opinion. The general view is that the brain as a whole sub-

<sup>1</sup> A paper read before the Biological Section of the British Association.

serves mental operations, and that there are no parts specially devoted to any particular functions. This has been recently expressed by so high an authority as Prof. Séquard. The idea rests chiefly on the numerous facts of disease with which we are acquainted. There are cases where extensive tracts of brain are destroyed by disease, or removed after a fracture, apparently with no result as regards the mind of the individual. Along with these facts we have others which are very curious, and which hardly seem to agree with this doctrine. One of these is, that when a certain part of the brain is diseased, in aphasia, the individual is unable to express himself in words. Other curious phenomena have been well described by Dr. Hughlings Jackson, viz., that certain tumors or pathological lesions in particular parts of the brain give rise, by the irritation which they keep up, to epileptiform convulsions of the whole of one side, or of the arm, or leg, or the muscles of the face; and, from studying the way in which these convulsions show themselves, he was able to localize very accurately the seat of the lesion.

The great difficulty in the study of the function of the brain has been, in the want of a proper method. When we study the function of a nerve, we make our experiments in two ways: In the first place, we irritate the nerve by scratching or by electricity, or by chemical action, and observe the effect; and, in the second place, we cut the nerve, and observe what is lost. In regard to the brain and nervous system, the method has been almost entirely, until recently, the method of section. It has been stated by physiologists that it is impossible to excite the brain into action by any stimulus that may be applied to it, even that of an electric current; they have, therefore, adopted the method of destroying parts of the brain. This method is liable to many fallacies. The brain is such a complex organ, that to destroy one part is necessarily to destroy many other parts, and the phenomena are so complex, that one cannot attribute their loss to the failure only of the parts which the physiologists have attempted to destroy.

About three years ago, two German physiologists, Fritsch and Hitzig, by passing galvanic currents through parts of the brains of dogs, obtained various movements of the limbs, such as adduction, flexion, and extension. They thus discovered an important method of research, but they did not pursue their experiments to the extent that they might have done, and perhaps did not exactly appreciate the significance of the facts at which they had arrived.

I was led to the experiments which I shall have to explain, by the effects of epilepsy and of chorea, which have been explained to depend upon irritation of parts of the brain. I endeavored to imitate the effects of disease on the lower animals, and determined to adopt the plan of stimulating the parts of the brain by electricity, after the manner described by Fritsch and Hitzig.

I operated on nearly a hundred animals of all classes—fish, frogs,

fowls, pigeons, rats, Guinea-pigs, rabbits, cats, dogs, jackals, and monkeys. The plan was to remove the skull, and keep the animal in a state of comparative insensibility by chloroform. So little was the operation felt, that I have known a monkey, with one side of the skull removed, awake out of the state induced by the chloroform, and proceed to catch fleas, or eat bread-and-butter. When the animal was exhausted, I sometimes gave it a little refreshment, which it took in the midst of the experiments.

First, as to the experiments on cats, I found that, on applying the electrode to a portion of the superior external convolution, the animal lifted its shoulder and paw (on the opposite side to that stimulated) as if about to walk forward; stimulating other parts of the same convolution, it brought the paw suddenly back, or put out its foot as if to grasp something, or brought forward its hind-leg as if about to walk, or held back its head as if astonished, or turned it on one side as if looking at something, according to the particular part stimulated. The actions produced by stimulating the various parts of the middle external convolution were, a drawing up of the side of the face, a backward movement of the whiskers, a turning of the head, and a contraction of the pupil, respectively. A similar treatment of the lower external convolution produced certain movements of the angles of the mouth; the animal opened the mouth widely, moved its tongue, and uttered loud cries, or mewed in a lively way, sometimes starting up and lashing its tail as if in a furious rage. The stimulation of one part of this convolution caused the animal to screw up its nostrils on the same side; and, curiously enough, it is that part which gives off a nerve to the nostril of the same side.

Results much of the same character were produced by the stimulation of the corresponding or homologous parts of the rat, the rabbit, and the monkey. Acting upon the anterior part of the ascending frontal convolution, the monkey was made to put forward its hand as if about to grasp. Stimulation of other portions acted upon the biceps, and produced a flexing of the forearm, or upon the zygomatic muscles. The part that appeared to be connected with the opening of the mouth and the movement of the tongue was homologous with the part affected in man in cases of aphasia. Stimulation of the middle temporo-sphenoidal convolution produced no results; but the lower temporo-sphenoidal, when acted upon, caused the monkey to shut its nostrils. No result was obtained in connection with the occipital lobes.

These experiments have an important bearing upon the diagnosis in certain kinds of cerebral disease, and the exact localization of the parts affected. I was able to produce epileptic convulsions of all kinds in the animals experimented upon, as well as phenomena resembling those of chorea or St. Vitus's dance. The experiments are also important anatomically, as indicating points of great significance in reference to the homology of the brain in lower animals and in man, and like-

wise served to explain some curious forms of expression common to man and the lower animals. The common tendency, when any strong exertion is made with the right hand, to retract the angle of the mouth and open the mouth on the same side, had been stated by Oken, in his "*Natur-geschichte*," to be due to the homology between the upper limbs and the upper jaw; the true explanation being that the movements of the fist and of the mouth are in such close relation to each other that, when one is made to act powerfully, the impression diffuses itself to the neighboring part of the brain, and the two act together.

The experiments have likewise a physiological significance. There is reason to believe that, when the different parts of the brain are stimulated, ideas are excited in the animals experimented upon, but it is difficult to say what the ideas are. There is, no doubt, a close relation between certain muscular movements and certain ideas, which may prove capable of explanation. This is supported by the phenomena of epileptic insanity. The most important guide on the psychological aspect of the question is the disease known as aphasia. The part of the brain which is the seat of the memory of words is that which governs the movements of the mouth and the tongue. In aphasia, the disease is generally on the left side of the brain, in the posterior part of the inferior frontal convolution, and it is generally associated with paralysis of the right hand, and the reason might be supposed to be that the part of the brain affected is nearly related to the part governing the movements of the right hand.

It is essential to remember that the movements of the mouth are governed bi-laterally from each hemisphere. The brain is symmetrical, and I hold it to be a mistake to suppose that the faculty of speech is localized on the left side of the brain. The reason why an individual loses his speech when the left side of the brain is diseased is simply this: Most persons are right-handed, and therefore left-brained, the left side of the brain governing the right side of the body. Men naturally seize a thing with the right hand, they naturally therefore use rather the left side of the brain than the right, and when there is disease, there the individual feels like one who has suddenly lost the use of his right arm.

I may, finally, briefly allude to the results of stimulating the different ganglia. Stimulation of the corpora striata causes the limbs to be flexed; the optic thalami produces no result: the corpora quadrigemina produce, when the anterior tubercles are acted upon, an intense dilatation of the pupil, and a tendency to draw back the head and extend the limbs as in opisthotonos; while the stimulation of the posterior tubercles leads to the production of all kinds of noises. By stimulating the cerebellum, various movements of the eyeballs are produced.—*Nature*.

## MARS, BY THE LATEST OBSERVATIONS.

FROM THE FRENCH OF CAMILLE FLAMMARION.

IN order successfully to observe Mars, two conditions are requisite: First, the earth's atmosphere must be clear at the point of observation; and, second, the atmosphere of Mars must be also free from clouds—for that planet, like the earth itself, is surrounded by an aerial atmosphere which from time to time is obscured by clouds just like our own. These clouds, as they spread themselves out over the continents and seas, form a white veil which either entirely or partially conceals from us the face of the planet. Hence the observation of Mars is not so easy a matter as it might at first appear. Then, too, the purest and most transparent terrestrial atmosphere is commonly traversed by rivers of air, some warm, some cold, which flow in different directions above our heads, so that it is almost impossible to sketch a planet like Mars, the image seen in the telescope being ever undulating, tremulous, and indistinct. I believe that, if we were to reckon up all the hours during which a perfect observation could be had of Mars, albeit his period of opposition occurs every two years, and although telescopes were invented more than two and a half centuries ago, the sum would not amount to more than one week of constant observation.

And yet, in spite of these unfavorable conditions, the Planet of War is the best known of them all. The moon alone, owing to its nearness to us, and the absence of atmosphere and clouds, has attracted more particular and assiduous study; and the geography (selenography<sup>1</sup> rather) of that satellite is now satisfactorily determined. That hemisphere of the moon which faces us is better known than the earth itself; its vast desert plains have been surveyed to within a few acres; its mountains and craters have been measured to within a few yards; while on the earth's surface there are 30,000,000 square kilometres (sixty times the extent of France), upon which the foot of man has never trod, which the eye of man has never seen. But, after the moon, Mars is the best known to us of all the heavenly bodies. No other planet can compare with him. Jupiter, which is the largest, and Saturn the fullest of curious interest, are both far more important than Mars, and more easily observed in their *ensemble*, owing to their size; but they are enveloped with an atmosphere which is always laden with clouds, and hence we never see their face. Uranus and Neptune are only bright points. Mercury is almost always eclipsed, like a courtier, by the rays of the sun. Venus alone may compare with Mars; she is as large as the earth, and consequently has twice the

<sup>1</sup> *Selene*, the moon.

diameter of Mars; besides, she is nearer to us, her least distance being about 30,000,000 miles. But, one objection is, that Venus revolves between the sun and us, so that, when she is nearest, her illuminated hemisphere is toward the sun, and we see only her dark hemisphere edged by a slight luminous crescent, or, rather, we do not see it at all. Hence it is that the surface of Venus is harder to observe than that of Mars, and hence, too, it is that Mars has the preëminence, and that in the sun's whole family he is the one with which we shall first gain acquaintance.

FIG. 1.

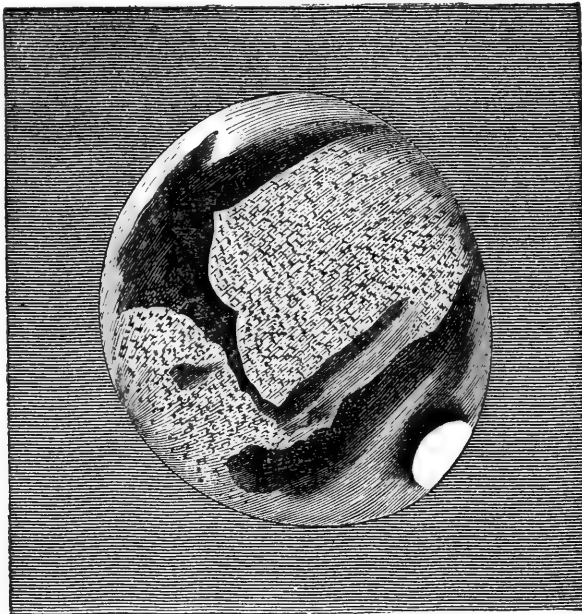

ASPECT OF MARS, WITH ITS CAP OF POLAR SNOW.

The geography of Mars has been studied and mapped out. What principally strikes one on studying this planet is that its poles, like those of the earth, are marked by two white zones, two caps of snow, one of which is shown in the cut. Sometimes both of these poles are so bright that they seem to extend beyond the true bounds of the planet. This is owing to that effect of irradiation which makes a white circle appear to us larger than a black circle of the same dimensions. These regions of ice vary in extent, according to the season of the year; they grow in thickness and superficial extent around both poles in the winter, melting again and retreating in the summer. They have a larger extension than our glacial regions, for sometimes they descend as far as Martial latitude  $45^{\circ}$ , which corresponds with the terrestrial latitude of France.

This first view of Mars shows an analogy with our own planet, in the distribution of climates into frigid, temperate, and torrid zones. The study of its topography will, on the other hand, show a very characteristic dissimilarity between the configuration of Mars and that of the earth. On our planet the seas have greater extent than the con-



tinents. Three-fourths of the surface of our globe is covered with water. The *terra firma* is divided chiefly into three great islands or continents, one extending from east to west, and constituting Europe and Asia; the second, situated to the south of Europe, in shape like a V with rounded angles, is Africa; the third is on the opposite side of the earth, and lies north and south, forming two V's, one above the other. If to these we add the minor continent of Australia, lying to the south of Asia, we have a general idea of the configuration of our globe.

It is different with the surface of Mars, where there is more land than sea, and where the continents, instead of being islands emerging from the liquid element, seem rather to make the oceans mere inland seas—genuine mediterraneans. In Mars there is neither an Atlantic nor a Pacific, and the journey round it might be made dry-shod. Its seas are mediterraneans, with gulfs of various shapes, extending hither and thither in great numbers into the *terra firma*, after the manner of our Red Sea.

FIG. 2.

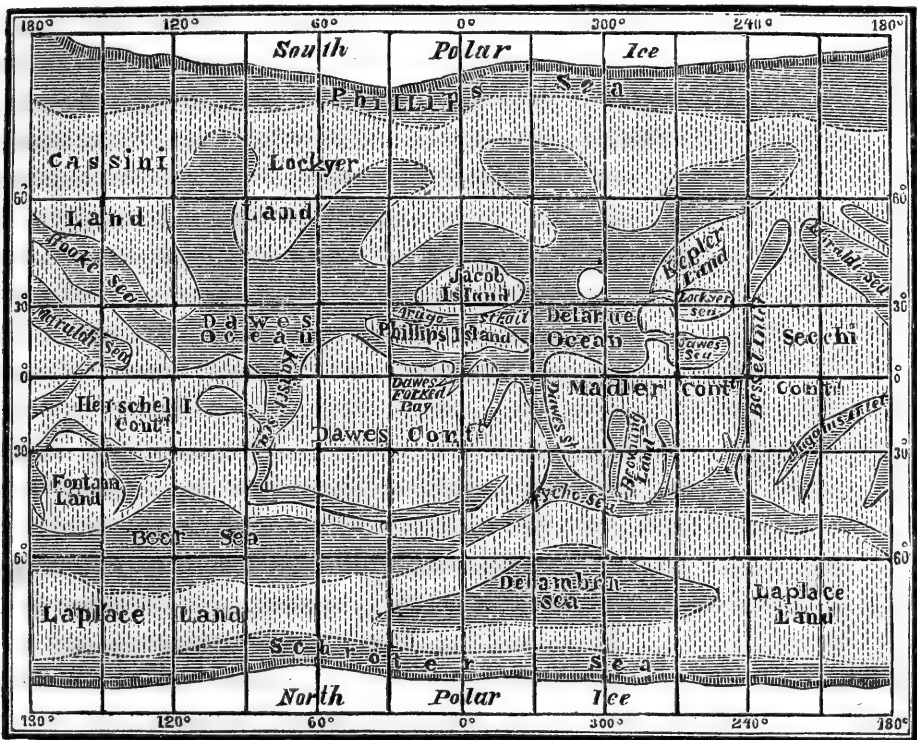

CHART OF THE SURFACE OF MARS, SHOWING THE DISTRIBUTION OF LAND AND WATER.

The second character, which also would make Mars recognizable at a distance, is that the seas lie in the southern hemisphere mostly, occupying but little space in the northern, and that these northern and southern seas are joined together by a thread of water. On the entire surface of Mars there are three such threads of water extending from the south to the north, but, as they are so wide apart, it is but rarely

that more than one of them can be seen at a time. The seas and the straits which connect them constitute a very distinctive character of Mars, and they are generally perceived whenever the telescope is directed upon that planet.

The continents of Mars are tinged of an ochre-red color, and its seas have for us the appearance of blotches of grayish green intensified by the contrast with the color of the continents. The color of the water on Mars is therefore that of terrestrial water. But why is the land there red? It was at one time supposed that this tinge must be owing to the Martial atmosphere. It does not follow that, because our atmosphere is blue, the atmosphere of the other planets must have the same color. Hence it was permissible to suppose that the atmosphere of Mars was red. In that case the poets of that world would sing the praises of that ardent hue, instead of the tender blue of our skies. In place of diamonds blazing in an azure vault, the stars would be for them golden fires flaming in a field of scarlet; the white clouds suspended in this red sky, and the splendors of sunset, would produce effects not less admirable than those which we behold from our own globe.

But the case is otherwise. The coloration of Mars is not owing to its atmosphere; for, although the latter is spread out over the entire planet, neither its seas nor its polar snows assume the red tinge; and Arago, by showing that the rim of the planet's disk is of a less deep tinge than the centre, proved that the color is not due to the atmosphere. If it were, then the rays reflected from the margin to us would be of a deeper red than those reflected from the centre, as having to pass through a greater height of atmosphere. May we attribute to the color of the herbage and plants, which no doubt clothe the plains of Mars, the characteristic hue of that planet, which is noticeable by the naked eye, and which led the ancients to personify it as a warrior? Are the meadows, the forests, and the fields, on Mars, all red? An observer, looking out from the moon, or from Venus, upon our own planet, would see our continents deeply tinged with green. But, in the fall, he would find this tint disappearing at the latitudes where the trees lose their leaves. He would see the fields varying in their hues, and then would come winter, when they would be covered with snow for months. On Mars the red coloration is constant; it is observed at all latitudes, and in winter no less than in summer. It varies only in proportion to the clearness of the atmospheres of Mars and the earth. Still this does not preclude the supposition that the Martial vegetation has its share in producing the red hue of the planet, though it be principally due to the color of the soil. The land cannot be all over bare of vegetation, like the sands of Sahara. It is very probably covered with a vegetation of some kind, and, as the only color we perceive on Mars's *terra firma* is red, we conclude that Martial vegetation is of that color.

We speak of plants on Mars, of the snows at its poles, of its seas, atmosphere, and clouds, as though we had seen them. Are we justified in tracing all these analogies? In fact, we see only blotches of red, green, and white, upon the little disk of the planet; but, is the red *terra firma*; the green, water; or the white, snow? Yes, we are now justified in saying that they are. For two centuries astronomers were in error with regard to spots on the moon, which were taken for seas, whereas they are motionless deserts, desolate regions where no breeze ever stirs. But it is otherwise as regards the spots on Mars.

The *unvarying* aspect of the moon never exhibits the slightest cloud upon its surface, nor do the occultations of stars by its disk reveal even the slightest traces of an atmosphere. Contrariwise, the aspect of Mars is *ever varying*. White spots move about over its disk, very often modifying its apparent configuration. These spots can be nothing else but clouds. The white spots at its poles increase or diminish with the seasons, exactly like the circumpolar ice of earth, which, for an observer on Venus, would have the same aspect and the same variations as the polar spots of Mars have for us. Hence we conclude that these Martial white polar spots are masses of frozen water. Each hemisphere of Mars is harder to observe during its winter than during its summer, being often covered with clouds over its greater part. This would be precisely the aspect of the earth if observed from Venus. But what causes these clouds over Mars? Plainly nothing else but the evaporation of water. As for the ice, that is the same water frozen. But is the water there the same as here? Down to a few years ago, this question remained unanswered, but now it admits of a reply, thanks to the spectroscope, and the observations especially of Mr. Huggins.

The planets reflect the light they receive from the sun; on examining their spectra, we find the solar spectrum as though it had been reflected from a mirror. If we direct the spectroscope on Mars, we get, first of all, an image perfectly identical with that produced by the central star of our system. But, by the employment of more exact methods, Mr. Huggins found, during the last opposition of the planet, that the spectrum of Mars is crossed, in its orange portion, by a group of black lines *coincident with the lines which appear in the solar spectrum at sunset* when the sun's light passes through the denser strata of our atmosphere. Now, are these tell-tale rays produced by our atmosphere? To decide this question, the spectroscope was turned on the moon, which was at the time nearer the horizon than Mars. If the lines in question were produced by our atmosphere, they must have appeared in the lunar as well as in the Martial spectrum, and with greater intensity in the former. Yet they were not to be seen at all in the lunar spectrum; and hence it is plain that they are owing to the atmosphere of Mars.

The atmosphere of that planet, therefore, adds these special char-

acters to those of the solar spectrum, and this proves that the atmosphere of Mars is analogous to that of earth. But what is that atmospheric matter which produces these significant lines? From an examination of their positions, we find that they are not owing to the presence of oxygen, nitrogen, or carbonic acid, but to watery vapor. Therefore, there is *water-vapor in the atmosphere of Mars*, as in that of the earth. The green spots on its globe are seas—expanses of water resembling our seas. The clouds are made up of minute vesicles of water, like our own mists; and the snows consist of water solidified by cold. Furthermore, this water, as revealed by the spectroscope, being of the same chemical composition as terrestrial waters, we know that Mars possesses oxygen and hydrogen.

These important data enable us to form an idea of Martial meteorology, and to recognize therein a reproduction of the meteorological phenomena of our own planet. On Mars, as on earth, the sun is the supreme agent of motion and of life. Heat vaporizes the water of the seas, causing it to ascend into the atmosphere. This vapor assumes visible shape by the same processes which produce clouds here, i. e., by differences of temperature and of saturation. Winds arise in virtue of these same differences of temperature. We can observe the clouds on Mars as they are swept along by air-currents over the seas and continents, and several observers have, so to speak, photographed these meteoric variations.

If we are as yet unable precisely to see the rain falling on the plains of Mars, we can at least tell when it is falling, for we can see the clouds dispersing and gathering again. Thus there is on Mars, just as on earth, an atmospheric circulation, and the drop of water which the sun takes from the sea returns thither after it has fallen from the cloud which concealed it. And, although we must sternly resist any tendency to fashion imaginary worlds after the pattern of our own, still Mars presents to us, as in a mirror, such an organic likeness to earth, that it is hard for us not to carry our description a little further.

Thus, then, we behold, in space, millions of miles away, a planet very much like our own, and where all the elements of life exist, as they do here—water, air, heat, light, winds, clouds, rain, streams, valleys, mountains. To complete the resemblance, the seasons there are very much the same as here, the axis of rotation of Mars having an inclination of  $27^{\circ}$ , while that of the earth is  $23^{\circ}$ . The Martial day is forty minutes longer than the terrestrial.

In the face of all these facts, can we be content with the conclusions we have so far reached without going further, and considering ulterior consequences? If the same physico-chemical conditions are present on Mars as on earth, why should they not produce the same effects there as here? On earth the smallest drop of water is peopled with myriads of animalcules, and earth and sea are filled with count-

less species of animals and plants; and it is not easy to conceive how, under similar conditions, another planet should be simply a vast and useless desert.—*La Nature*.

---

## TENNYSON AND BOTANY.

BY J. HUTCHISON.

WORDSWORTH, in the supplementary preface contained in the second volume of his works, asserts in the most emphatic way the deplorable ignorance of “the most obvious and important phenomena” of Nature which characterizes the poetical literature of the period intervening between the publication of the “Paradise Lost” and the “Seasons.” It is to be feared that his opinion is, to a large extent, justified by the facts of the case. A very cursory examination of the productions of the poets who flourished during the seventy years referred to will suffice to show how little they were affected by the manifold beauty and grandeur of the visible universe everywhere around them. In this respect they contrast unfavorably, not only with their successors of the present century, which might have been expected, but with those of the two preceding centuries as well. The latter, whose works embrace a period dating back a hundred years from Milton, display, generally, a much more accurate acquaintance with the appearances and phenomena of the natural world, and spontaneousness in the expression of it, than the school of Dryden and Pope, who may be regarded as the most conspicuous examples of Wordsworth’s strictures. Of Pope, particularly, it might almost be said that, from his writings, it could scarcely be inferred that there was much else in existence than courts, and fashion, and scandal—not much, at all events, that was worth caring for. He excelled in the representation of the modish life of the day—its fine ladies with their patches, its fine gentlemen with their periwigs, and its general artificiality. Of Nature in its endless continuity, and variety, and mysteriousness, which has stirred the hearts of men in every age, and kindled many smaller poets into enthusiasm, he knew and cared little, and the trim alleys and botanical distortions of Versailles, which he has characteristically described, may be taken as typical of his own inspiration on the matter. It may be worth while mentioning, as a pertinent illustration of these comments, that in his poem of “Windsor Forest,” with the exception of a semi-patriotic allusion to the oak, in connection with ship-building, there is not a reference to a single forest-tree, not even to any of those famous historical oaks which abound in the locality. Nature and simplicity, in truth, had gone out of fashion, and were not much in vogue again till far on in the century.

Darwin, a mere poetaster compared with the genius of Twickenham, is a well-known instance of the opposite defect—of the absence

of poetic fire rather than of a taste for the delights of the country. His "Botanic Garden" is a dreary, mechanical affair, several degrees worse and more unreadable than Cowley's "Plants," a century earlier. Both are constructed on an altogether erroneous principle. Science is science, and poetry is poetry; and while, as is well illustrated in "The Princess" and "In Memoriam," the scientific spirit may be distinctly present, yet any thing like a formal, didactic attempt at amalgamation is certain to prove a failure.

Although belonging to an earlier date than the sterile period referred to, George Herbert might also be quoted here as a case of poetic talent of a very genuine kind, yet unaccompanied by much perception of natural beauty or picturesqueness. He has sometimes been likened to Keble, a brother churchman and clergyman, but between the two, in their feeling and apprehension of the wonders of creation, the difference is singular and complete. Herbert's strong point was spiritual anatomy. His probing and exposure of the deceits and vanities of the human heart, and his setting forth of the dangers of the world to spirituality of mind, are at once quaint and incisive. But of any love or special knowledge of the physical world there is scarcely a trace.<sup>1</sup> Keble's poetry, on the other hand, quite as unworldly as that of the author of "The Temple," is redolent everywhere of the sights and sounds of Nature. The seasons with their endless changes, the motions of the heavenly bodies, the fragrance of the field, trees, rivers, mountains, and all material things, are assimilated, so to speak, into the very essence of his verse. That very world which to Herbert was only base and utterly indifferent, seemed to Keble, to use his own words, "ennobled and glorified," and awakened in his soul poetical emotions of the highest and purest kind.

It is unnecessary to enter into much detail in order to show how much more truly than himself, Pope's predecessors, and especially those of the Elizabethan era, were entitled to the designation of poets of Nature. Shakespeare, Spenser, the two Fletchers, Milton, and many others, might be adduced in confirmation. With reference to botany, it is evident that the greatest of the tribe, in his universality of knowledge, flowing over into every region of human research, was well acquainted with the subject in its twofold aspect—trees and flowers. Many beautiful floral descriptions occur in the plays, and although the arboricultural allusions are less frequent, they are sufficiently numerous to justify the belief that his knowledge was both extensive and accurate. Perhaps the most important passage of the kind is where Cranmer, "dilating on a wind of prophecy," portrays, under the figure of a "mountain-cedar," the future glories of the reigns of Elizabeth and her successor.<sup>2</sup> Milton has many striking and appro-

<sup>1</sup> One of his biographers has discovered a solitary verse, on the faith of which he complacently assumes that Herbert "was thoroughly alive to the sweet influences of Nature."

<sup>2</sup> Commentators affirm Ben Jonson to be the author of the lines referred to.



priate images borrowed from trees. His artistic use of the pine as a simile for Satan's spear—

“ to equal which the tallest pine,  
Hewn on Norwegian hills to be the mast  
Of some great ammiral, were but a wand ”—

and the comparison of the rebel host to blasted pines, are fine examples of the poetical transmutation of botanical knowledge. Still finer is the exquisite description in “*Lycidas*” of the vernal flowers strewed on the hearse of his lamented friend. And, not to multiply quotations further, the vale of Vallombrosa has been immortalized forever by three lines in “*Paradise Lost*.”<sup>1</sup>

In later poetry, not of the present century, Shenstone and Cowper were both genuine lovers of Nature, and their works abound with passages relating to rural pleasures and scenery. Cowper, indeed, might be styled *par excellence* the poet of the country. No one ever believed more thoroughly than himself in his own epigrammatic line—

“ God made the country, and man made the town.”

The revolution in the poetical taste of the time, afterward consummated by Wordsworth, was mainly initiated by the recluse of Olney. In Shenstone's poems, now, it is to be feared, little read, there are some verses bearing on the subject of this essay which have a curious resemblance to Mr. Tennyson's famous song, “*Come into the garden, Maud*.” We quote eight lines to be found in the piece designated a “*Pastoral Ballad, in Four Parts* : ”

“ From the plains, from the woodlands and groves,  
What strains of wild melody flow !  
How the nightingales warble their loves  
From thickets of roses that blow !

“ Then the lily no longer is white ;  
Then the rose is deprived of its bloom ;  
Then the violets die with despite,  
And the woodbines give up their perfume.”

The ring and manner of this are very similar to Mr. Tennyson's composition, and, although the measure is a little different, these verses might be interpolated in the modern song without in the least impairing its harmony, or affecting its verisimilitude.

The most distinguished names in the list of the natural poets of the present century are undoubtedly Sir Walter Scott, Wordsworth, and Mr. Tennyson. Of the two former it may be said, in passing,

<sup>1</sup> “ Till on the beach  
Of that inflamèd sea he stood, and called  
His legions, angel forms, who lay intranced,  
Thick as autumnal leaves that strew the brooks  
In Vallombrosa.”

that they have probably done more than anybody else to foster the modern idea of Nature, and the love of wild and picturesque scenery. Our business, however, is more particularly with Mr. Tennyson, and with the evidences of botanical knowledge to be found in his works, that part of botany, at least, relating to trees. These allusions, we apprehend, are more numerous, and show more insight, and acquaintance with the forms, and processes, and changes characteristic of the inhabitants of the forest, than those of any other modern author. His verse in this respect differs from other descriptive poetry chiefly in this, that his notices are not general appellations or similitudes applicable equally to any or all trees, but are specific, exact, and true only in the particular case. Thomson, for example, in the "Seasons," is, in general, curiously vague in his descriptions. He generalizes constantly, and presents his readers with broad effects sketched *en masse*, instead of individual details. Such phrases as "sylvan glades," "vocal groves," "umbrageous shades," and the like, frequently occur, doing duty in place of more minute representations. Mr. Tennyson, on the other hand (and Sir Walter and Wordsworth may also be included), pursues exactly the contrary method. His descriptions are, nearly always, pictures of particular places instead of fancy sketches, and the distinguishing features are given incidentally in the course of the narrative. Where, again, particular trees are referred to, it is almost invariably with a phrase or an epithet clinching the description as precisely as a paragraph from Evelyn or Loudon. And, as poetry, these casual, accidental bits of descriptive writing are infinitely more effective than any amount of versified disquisition, of the Darwin sort, on the processes of vegetation. Slight, too, though in many cases they are, they indicate a deep appreciation of the results and tendencies of modern science. In what remains of this paper it is proposed, a little in detail, to adduce evidence from Mr. Tennyson's poems in support of the views we have expressed. It will not be necessary to go over the whole field, and we shall therefore select a few of the more important trees, and see to what extent his notices of them are corroborative of these preliminary remarks.

The ash will be the first example, and the reference in the lines quoted below is to the proverbial lateness of this tree in developing its foliage. It forms part of the Prince's song in "The Princess:"

"Why lingereth she to clothe her heart with love,  
 Delaying as the tender ash delays  
 To clothe herself, when all the woods are green?"

This is a very striking comparison, happily expressed, and, besides serving its immediate purpose, corrects an erroneous notion, somewhat popular, that sometimes the ash and sometimes the oak is in leaf first. Then, again, in "The Gardener's Daughter," Juliet's eyes and hair are thus described:

“Love, unperceived,  
Came, drew your pencil from you, made those eyes  
Darker than darkest pansies, and that hair  
More black than ash-buds in the front of March;”

a fact which all observers of the phenomena of the spring months will recognize as accurate.

The lime seems a special favorite of Mr. Tennyson, so lovingly and frequently does he use it for illustration. There is much imitative beauty in the well-known lines (also from “The Gardener’s Daughter”) which form the conclusion of the description of a cathedral city—possibly Peterborough:

“And all about the large lime-feathers low,  
The lime a summer home of murmurous wings.”

The giving out of branches close to the ground is a noticeable habit of the lime, as it is also, to some extent, of the elm, particularly in Devonshire. The mode of growth and the development of the branches are still further illustrated:

“Not thrice your branching limes have blown  
Since I beheld young Laurence dead.”

The epithet “branching” refers to another peculiarity—the number and intricacy of the branches in the centre of the tree. On this point Mr. Leo Grindon, a good authority, says: “So dense is the mass, that to climb a full-grown tree is nearly impossible.” The frequent use of the lime for avenues and walks, a practice still more prevalent on the Continent, is very pictorially stated:

“and overhead,  
The broad ambrosial aisles of lofty lime  
Made noise with bees and breeze from end to end.”

Its spring-time is photographed in “Maud” in a single sentence, thus:

“A million emeralds break from the ruby-budded lime.”

Every student of botany will be able to verify the correctness of this line. The buds are peculiarly red, and the appearance of thousands of them bursting at once is precisely as the poet describes it. Elsewhere, the period immediately preceding the foliation of the tree is sketched with remarkable truthfulness:

“On such a time as goes before the leaf,  
When all the wood stands in a mist of green,  
And nothing perfect.”

The Spanish chestnut, *Castanea*, is not one of Mr. Tennyson’s trees; but there are frequent references to the horse-chestnut, *Æsculus*. The three chestnuts in “The Miller’s Daughter” will be in the recollection of most readers of his poetry. The appearance of the buds

just before emerging from their green covering, and the time of their development, are registered with minute accuracy:

“But, Alice, what an hour was that,  
When, after roving in the woods  
(’Twas April then), I came and sat  
Below the chestnuts, when their buds  
Were glistening in the breezy blue!”

“Glistening” is the exact epithet here. The early foliation of the chestnut and elm we find in the exquisite fragment “Sir Launcelot and Queen Guinevere.” The lines on the chestnut are very characteristic:

“In curves the yellowing river ran,  
And drooping chestnut-buds began  
To spread into the perfect fan,  
Above the teeming ground.”

This, with the similar remark on the elm, corresponds to the order of Nature, and is nowhere better or more beautifully exemplified than in Kensington Gardens every April.

So far as we have been able to discover, there is only a single line devoted to the birch. It is to be found in “Amphion,” that singular reproduction, in sylvan form, of the mythological legend. It is interesting to notice, by-the-way, that, in the later editions, the verse in which the birch is mentioned is omitted, and another substituted. As a whole, the latter is doubtless the more musical of the two, but we are sorry to lose the apt and charming characterization of “the lady of the woods.” For the curious in Tennysonianism we print both:

“The birch-tree swang her fragrant hair,  
The bramble cast her berry,  
The gin within the juniper  
Began to make him merry.”

“The linden broke her ranks and rent  
The woodbine-wreaths that bind her,  
And down the middle, buzz! she went  
With all her bees behind her.”

Of all the poets who have sung the praises of the birch, Coleridge, Keats, and, preëminently Sir Walter Scott, none of them has surpassed the initial line of the first stanza in condensed and subtile expressiveness. Scott’s is somewhat similar, although not quite so good:

“Where weeps the birch with silver bark,  
And long dishevelled hair.”

“Dishevelled,” implying disorders and entanglement, does not convey a correct idea of the foliage of the birch. “Swang her fragrant hair” is decidedly better.

The fullness and ripeness of the poet’s knowledge of trees are amply

illustrated in those passages of his poems relating to the poplar. This is a tree with which he has been familiar from early childhood, as we gather from the "Ode to Memory," where he fondly recalls—

"The seven elms, the poplars four,  
That stand beside my father's door."

The famous poplar in "Mariana," which Mr. Read has reproduced in his fine picture of the "Moated Grange," now at South Kensington, is a prominent object in a very striking poem. The locality, it is scarcely necessary to say, is the fen country:

"About a stone-cast from the wall  
A sluice with blackened waters slept,  
And o'er it many, round and small,  
The clustered marish-mosses crept.  
Hard by a poplar shook alway,  
All silver-green with gnarlèd bark;  
For leagues no other tree did mark  
The level waste, the rounding gray."

As an example of landscape-painting in words, there is nothing more perfect than this in modern literature. We are not aware if the doubt was ever suggested before, but we think it is at least questionable if Mr. Read is right in assuming the particular tree in his poem to be a Lombardy poplar. "Silver-green," a remarkable epithet, is more applicable to the abele, or white poplar, than to the fastigiata Lombardy species, and the sound of the trembling of the leaves is less noticeable in the latter than in most of the other poplars. In other poems this rustling noise is described as "lipping," "hissing," and like the sound of "falling showers," phrases all tolerably approximating to exactness. In "In Memoriam" there is a special reference to this white poplar whose silver-green foliage shows much more white than green in a gale of wind:

"With blasts that blow the poplar white,  
And lash with storm the streaming pane."

The "quivering," "tremulous" aspen is also mentioned, but Mr. Tennyson is too good a botanist to fall into the popular error of supposing that it is the only tree which has fluttering leaves. Except the Ontario species and one or two others, nearly all the poplars have the same peculiarity, caused, it may not be superfluous to say, by the compression of the leaf-stalk. Very curious it is to notice in the upper branches, while a light wind is overhead, each particular leaf shaking on its own account, while the branch of which it is a part, and the tree itself, are perfectly motionless.

Of the beech the notices are scantier and less specific. Its peculiarly twisted roots, rich autumn tints, smooth bark, and unusual leafiness, are all described, however, more or less poetically. The following verse from "In Memoriam" has a certain pensive sweetness of its own:

“Unwatched, the garden bough shall sway,  
The tender blossom flutter down,  
Unloved that beech will gather brown,  
This maple burn itself away.”

The rich autumn tints of the foliage of the maple are here alluded to.

Cedars, cypresses, and yews, all members of the great coniferous family, are prominent objects in Mr. Tennyson's landscapes. In the eighteenth section of “Maud”—beginning,

“I have led her home, my love, my only friend”—

and which contains some passages full of solemn tenderness and beauty, and a splendor of language worthy of Shakespeare himself, occurs the oft-quoted apostrophe addressed to the cedar of Lebanon by Maud's somewhat distempered, though now happy lover :

“Oh, art thou sighing for Lebanon  
In the long breeze that streams to thy delicious East,  
Sighing for Lebanon,  
Dark cedar. . . . .  
. . . . .

“And over whom thy darkness must have spread  
With such delight as theirs of old, thy great  
Forefathers of the thornless garden, there  
Shadowing the snow-limbed Eve from whom she came.  
Here will I lie, while these long branches sway.”

The yew, though usually regarded as the emblem of death—

“Cheerless, unsocial plant, that loves to dwell  
Midst skulls and coffins, epitaphs and tombs”—

might, in its extreme tenacity and length of days, be a fitter representative of life and endurance. In the second chapter of “In Memoriam” the yew is described in the most masterly manner. These are two of the verses :

“Old Yew, which graspest at the stones  
That name the underlying dead,  
Thy fibres net the dreamless head,  
Thy roots are wrapped about the bones.”

“Oh, not for thee the glow, the bloom,  
Who changest not in any gale,  
Nor branding summer suns avail  
To touch thy thousand years of gloom.”

The locality, the hue, the prolonged life, and the general unchangeableness of appearance, are all here summarily noticed. The laureate seems, however, to share the popular dislike to this tree, a feeling which Gilpin, in his “Forest Scenery,” ridicules as weakness. In “Amphion,” yews are called “a dismal coterie;” in “Maud” a “black yew gloomed the stagnant air;” and, in “Love and Death,”



we have the portentous image of the angel of death walking all alone "beneath a yew."

Our limits forbid more than a mere enumerative mention of other well-known trees, whose memory Mr. Tennyson has rendered sweeter to all future generations of tree-lovers. "Immemorial elms," "perky larches and pines," "laburnums, dropping-wells of fire," elders, hollies, "the pillared dusk of sounding sycamores," "dry-tongued laurels," "slender acacias"—all these and many others are to be found within the four corners of his poems. One only remains, the oak—"sole king of forests all;" and, as Mr. Tennyson has celebrated the praises of the monarch of the woods at great length in the "Talking Oak," we shall add a few words on that charming composition by way of conclusion.

As is well known, the poem takes the form of a colloquy between an ancient oak, which formed a meeting-place for two lovers, and the young gentleman in the case. He comes to question the tree about his lady-love, who had visited the hallowed spot in his absence. And Landor himself, in his happiest vein, never conceived a more exquisite imaginary conversation. Here, in sportive phrase and bantering talk, is the whole philosophy of forest-life set forth with a poetic felicity, saucy humor, and scientific precision of language, each admirable of its kind. The poem is literally a love-idyl and botanic treatise combined, and never, surely, were lovers and science—January and May, might one say—so delightfully harmonized, conveying, too, to those who have eyes to see and hearts to understand, glimpses of a spiritual interpretation of Nature, undreamt of by Pope and his school. Thus pleasantly does the old oak of "Sumner Chace" discourse to Walter of Olivia's charms; and the reader will not fail to notice the skillful way in which the poet's practical acquaintance with trees is turned to account:

"I swear (and else may insects prick  
Each leaf into a gall)  
This girl, for whom your heart is sick,  
Is three times worth them all;"

and then, with a warmth of praise unusual and almost improper in such a venerable inhabitant of the forest, he continues:

"Her kisses were so close and kind,  
That, trust me on my word,  
Hard wood I am, and wrinkled rind,  
But yet my sap was stirred:

"And even into my inmost ring  
A pleasure I discerned,  
Like those blind motions of the spring,  
That show the year is turned."

Farther on, the not ungrateful lover invokes all atmospheric and

- other good influences on his partner in the dialogue, who has proved so communicative a companion :

“O rock upon thy towery top  
 All throats that gurgle sweet!  
 All starry culmination drop  
 Balm-dews to bathe thy feet!

“Nor ever lightning char thy grain,  
 But, rolling as in sleep,  
 Low thunders bring the mellow rain,  
 That makes thee broad and deep!”

These, it will be admitted, are very melodious strains. Seldom has the imagery of the woods been used with more appropriateness and effect than in this poem, and its poetic excellence is rivaled by its accuracy. No one but an accomplished practical botanist could have written it. And throughout the poem, light and airy in tone as it is, there is distinctly perceptible the scientific element—the sense of the forces of Nature acting according to law, which, as we have already said, pervades like a subtile essence much of Mr. Tennyson’s poetry. But enough has probably been said to justify the title of this article.—*St. Paul’s Magazine.*



## “WATER TURNED TO BLOOD.”

FROM THE FRENCH OF DR. N. JOLY.

FROM the remotest antiquity the red color sometimes observed in water appears to have attracted attention. In all ages there have been stories of rains of blood, and of rivers changed to blood, and these phenomena have given rise to the most ludicrous explanations, and to the most ridiculous apprehensions. In Exodus (vii., 20, 21), we read: “All the waters that were in the river were turned to blood. And there was blood throughout all the land of Egypt.” Homer speaks of the dews of blood which preceded the Trojan War, and those which foreboded the death of Sarpedon, king of the Lycians. Pliny in his “Natural History” (book ii., c. xxxvi.) tells of a rain of milk and blood which fell at Rome in the consulship of M. Acilius and C. Portius. Finally, the historian Livy mentions a rain of blood which fell in the Forum Boarium. In times much nearer to our own, phenomena of this kind have been observed at various points in Europe, producing ridiculous alarms, and even leading to actual seditions.

The cause, or causes rather, of these so-called rains of blood are now well understood. Every one knows that they are to be attributed

either to mineral particles diffused through the air strata which are traversed by the rain, or to the dejections of certain moths in their last metamorphosis, or to the remains of infusoria carried up by the

FIG. 1.

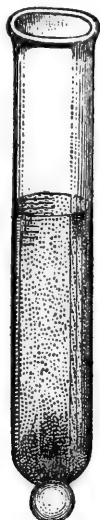

RED WATER OF THE SALT-MARSHES,  
taken from the surface.

FIG. 2.



The same after it has been allowed to  
rest. (The infusoria have risen  
to the surface.)

winds. But the ignorant multitude continue still to believe in rains of blood, and bow down blindly before so-called miracles which have no existence save in the wild fancies of those who regard them as articles of faith.

We are not concerned now with these errors and superstitions, on which modern science has pronounced its verdict; we propose rather to consider some well-attested facts, the causes of which leave no room for doubt or ambiguity. It is now ascertained beyond question that, where fresh water wears a peculiar tinge, this coloring is due to the presence of infusoria (*Euglena viridis*, *E. sanguinea*, *Astasia hæmatodes*), or to microscopic vegetation (*Oscillatoria rubescens*, *Sphæroplea annulina*), or to minute entomostraca (*Daphnia pulex*, *Cyclops quadricornis*).

The waters of the sea may also be tinged in a similar way. Thus, in 1820, Scoresby found that the blue or green tinge of the Greenland Sea was caused by an animalcule allied to the medusæ. Of these he counted 64 in a cubic inch; this would be in a cubic foot 110,392, and 23,888,000,000,000 in a cubic mile. According to Arago, the long and sharply-defined streaks of green in the polar seas include myriads of medusæ, whose yellow color, added to the blue of the water, produces green. Off Cape Palmas, on the Guinea coast, Captain Tuckey's ship appeared to be sailing through a milky sea. The cause of the phenomenon was the multitude of animals floating at the surface, and masking the natural tint of the water. The carmine-red streaks which various navigators have sailed through on the high-seas are produced in the

same way. In 1844 Messrs. Turrel and Freycinet saw the Atlantic Ocean, off the coast of Portugal, of a deep-red color, owing to the presence of a microscopic plant of the genus *Protococcus* (*P. Atlanticus*). This color was diffused over an area of no less than five square miles. M. Montagne, who has described the alga which produced this

FIG. 3.

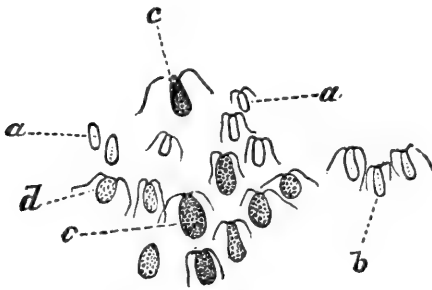

MONAS DUNALII MAGNIFIED.—*a*. Very young individuals, colorless. *b*. Individuals not yet full grown, colored green. *c*. Adults very deep red. *d*. Adults of lighter red.

FIG. 4.

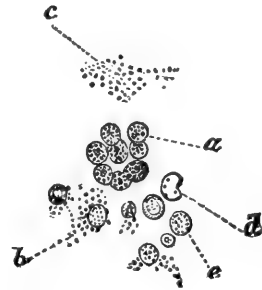

MONAS DUNALII, dead, and of globular shape.

phenomenon, closes his memoir in these words: "When we reflect that, in order to cover one square millimetre (0.03937 inch), we must have 40,000 individuals of this microscopic alga, we are filled with amazement on comparing the immensity of such a phenomenon with the minuteness of the cause which produces it."

As for the waters of the Red Sea, the periodic reddening which distinguishes them is caused by the presence of a confervoid alga which naturalists have called *Trichodesmium erythraeum*. Finally, Pallas tells of a lake in Russia, called Malinovoé-Ozéro, or Raspberry Lake, because its briny water and the salt made from it are red, and have the odor of violets.

The coloration of the Mediterranean salt-marshes, a phenomenon long known to the salt-makers of Languedoc, but first studied by *savants* in 1836, and by me in 1839, has also been explained in various ways more or less near the truth. Messrs. Audouin, Dumas, and Payen, of the Institute, have attributed it to the *Artemia salina*, a minute branchiopod crustacean, which in fact swarms in the *partennements*,<sup>1</sup> where the saltiness of the water is far below the degree of saturation requisite for the precipitation of salt crystals, but is of much rarer occurrence where the water, being very highly concentrated, assumes at times a blood-red color. Messrs. A. de Saint-Hilaire and Turpin have supposed the real cause of this strange coloration to be certain microscopic plants, of very simple organization, which they call *Protococcus sanguineus* and *Hæmatococcus kermesinus*. This, too, was the opinion of M. F. Dunal, who had studied the rubefaction of

<sup>1</sup> The *sauniers* (salt-makers) of Languedoc give the names of *tables*, *partennements*, and *pièces maitresses* to the various compartments into which the sea-water is passed as it arrives at different degrees of salinity.

the water of our salt-marshes before St.-Hilaire and Turpin. As I was at that time employed in teaching Natural History in the Royal College of Montpellier, where I had among my pupils several youths who have since become distinguished masters themselves (Louis Figuier, Amédée Courty, and Henri Marès, for instance), I too had a desire to study the curious phenomenon of the reddening of water, and to this end I visited the salt-works of Villeneuve, two or three miles distant from Montpellier. The water there was then of a very decided red color. I collected on the spot some samples of the water which looked most like blood, and also of water which, being less briny than this, was also of a fainter red color. Under the microscope the water collected in the various compartments exhibited myriads of minute creatures, with oval or oblong bodies, often compressed in the middle, but sometimes cylindrical. Very young individuals were colorless, those a little older were greenish, and the adult were of a deep red. The mouth had the form of a conical prolongation, and was retractile; they were eyeless, and the stomach and anus could not be clearly made out.

FIG. 5.

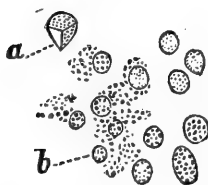

DEAD MONADS, colorless.

FIG. 6.

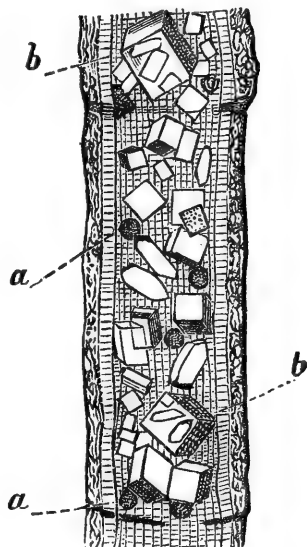

PART OF THE DIGESTIVE TUBE OF ARTEMIA SALINA, in which are seen (a, a) dead but not digested monads, and (b, b) cubical salt-crystals.

With a high-power microscope I was able to see in the anterior part of these supposed *protococci* two long, flagelliform, and perfectly transparent processes which they kept in rapid motion, and by means of which they swam about in the drop of liquid spread out on the slide of my instrument. There was no longer room for doubt. The *protococci* and *hæmatococci* of Messrs. Dunal, St.-Hilaire, and Turpin, were animals—true *monads*, and I gave them the name of *Monas Dunalii*, in honor of my preceptor, Prof. Dunal. He was the first to suspect the true cause of the red color of the Mediterranean salt-marshes; but he had only an indistinct insight into the matter. He examined the

animalcules only after they were dead, that is, at the moment when they had become globular and motionless, like *protococci*; and his specimens were dead, because he had filled his vials up to the brim with the water, and then sealed them hermetically. But these little animals must, above all things, have free respiration. Accumulated in immense numbers in a very small quantity of water, with the outer air entirely excluded, they all died while being carried from Villeneuve to Montpellier. They were then taken for *protococci*, being motionless and globular. I took precautions against committing this mistake, by only half filling my specimen-tubes, and, better still, by examining the water of the salines on the spot.

FIG. 7.

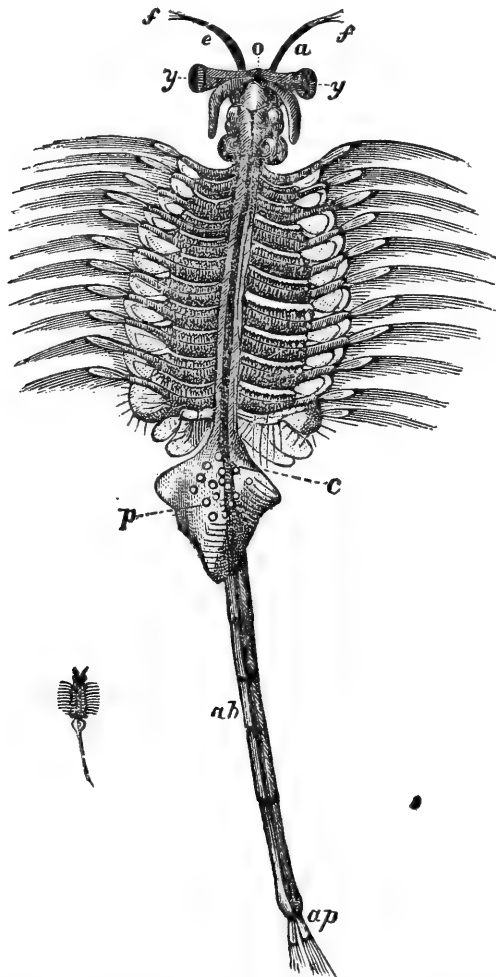

ARTEMIA SALINA (adult) natural size, and highly magnified. *o.* Median eye. *y, y.* Pedunculate eyes. *a, e.* Antennæ. *p.* Incubatory pouch with eggs. *ab.* Abdomen. *ap.* Tail-shaped appendages. *c.* Digestive tube.

It is a remarkable fact in the history of the *Monas Dunalii* that, like the *Protococcus nivalis*, which gives to the snow of the polar regions now a green tinge, anon a red, this animalcule presents, when young, a green tinge, which changes later to brick-red, and then to blood-red.



The degree of concentration of the water has a marked influence on them. On the 1st October, 1839, after the driest summer on record, the liquid in the *tables* indicated 25° salinity in Baumé's areometer, and it was of so deep a color as to stain a corner of my pocket-handkerchief a blood-red. On October 28th, after twenty-eight days of steady rain, the water in the *pièces maîtresses*, instead of presenting a purple color, as on the first day of the month, resembled blood with a very large amount of serum, and the monads in it were less numerous, and of a lighter red, although the water was still of 20° salinity.

Finally, we must not omit to state that the monads are very sensitive to light, which they seek with a certain degree of avidity. This may be easily seen by putting a number of these infusoria into a flask two-thirds filled with sea-water. Soon they will be seen to rise to the surface of the liquid, and to crowd together on the side where the light is strongest. If the flask be turned about so as to bring them on the darker side, they soon take their former position again. We must also observe that these animalcules sometimes go down to the bottom of the *tables*, and then the coloration of the surface grows fainter, or entirely disappears.

From all this it follows that the red color of the Mediterranean salt-marshes is caused by the *Monas Dunalii*; but is that animalcule the only cause of the phenomenon? Has not the *Artemia salina* of Audouin, Dumas, and Payen, also something to do with it? This problem was soon solved. We have first to bear in mind that these little crustaceans are found in far greater numbers in brackish water than in water at its maximum point of concentration, and that in the latter case, indeed, they occur so rarely that their presence may be regarded as in some sort merely accidental. In water of this kind, the *artemia* appears to be sickly; it evidently languishes in the over-dense medium; it swims about with difficulty, always keeping at the surface. It is more or less of a red color along the line of its digestive canal; but this coloration is a secondary thing, and is owing to the monads it has swallowed in water. The latter deposits in their intestine salt-crystals, which may be seen through their transparent envelope, mingled with monads in a state of partial or total digestion.

Far, then, from being the cause of the purple tint of salt-water in its last stage of concentration, the *artemia* is indebted for its accidental coloring to the *Monades Dunalii* it takes into its digestive canal, or which settle among the filaments of its branchial feet. This I have demonstrated by keeping colorless *artemiæ* for a while in water tinged by red monads, or simply by carmine, and so giving them a red color.

But, though the *artemia* has nothing to do with the coloration of water, it is, nevertheless, a subject of wonder and study for the physiologist. Like several other animals belonging to the great sub-kingdom *Articulata* (psyche, bee, silk-worm moth), our crustaceans possess the singular privilege of reproducing themselves without being sub.

jected to the general law of sexual union. Among several thousand artemiæ studied by me, I have not found a single well-defined male individual. The distinguished Genevan naturalist, Carl Vogt, said, the other day, that he had had the like experience. Hence we may conclude that the artemia of our salt-marshes perpetuates its kind by means of virgin females, whose eggs, although deprived of seminal impregnation, are developed in an incubatory sac situated at the base of the maternal abdomen. These produce young artemiæ, which have to undergo amazing metamorphoses before they arrive at a complete resemblance to their parent. The name of parthenogenesis has been bestowed on this singular mode of reproduction by virgin females, independently of commerce with males; oftentimes, the latter do not exist at all, or at least are as yet unknown. In conclusion, we would remark that the eggs of our virgin artemia produce only females, while the unfecundated eggs of the queen-bee produce males, and males only.—*La Nature*.

---

## THE REQUIREMENTS OF SCIENTIFIC EDUCATION.<sup>1</sup>

BY PROF. R. W. RAYMOND.

THERE is danger that, in our new-born zeal for scientific education, we may sacrifice the interests of a truly liberal culture, producing, as I have said, a generation of specialists, incapable of appreciating the departments of human thought which lie outside their own, or even of rising within their own departments to broad and comprehensive views. We must not use the microscope till we spoil the eyes. We must not overtrain the investigator until he becomes less than a full man. The chemists, geologists, and engineers, must not cease to be intelligent and active citizens. It may be demonstrated that such a mistaken neglect of studies outside the range of a chosen profession cripples activity and impairs success even in that profession. It is one result of the brotherhood of knowledge that no man, whether employed in the original investigation of Nature, or in the application of natural laws to practical ends, can advance successfully without perpetual communication of his thoughts to others, and the reception of their suggestions and experiences in return. Hence the mastery of language, which was the first condition of civilization, remains the essential condition of progress. The power to comprehend statements, logical arguments, and demonstrations, and to make such statements as may be comprehended by others, and will carry weight and influence in the very perfection of their form, is a vitally important part

<sup>1</sup> Extract from the Inaugural Address at the dedication of Pardee Hall, of Lafayette College, Easton, Pa., by Rossiter W. Raymond, President of the American Institute of Mining Engineers.

of the preparation of every young man for his life's career. His success, aside from his moral qualities, will be in direct proportion to his influence over other men; and this influence, again, will be in part proportional to his command of the means by which the minds of men are moved, mainly, language. Under this term we may include a knowledge of the methods of practical reasoning, and if this knowledge is best obtained by scholastic study of logic, then logic must be studied. If Latin and Greek are necessary, then they must be studied. For us, one thing is necessary—a thorough mastery of the English tongue—and this alone has been made to yield, in Lafayette College, a mental discipline not inferior to that of the classics.

But influence is not due to language alone. Behind this vehicle of thought there must be fullness and variety of thought itself. Those fruitful analogies, felicitous illustrations, graceful associations, which come, and come alone, through wide acquaintance with human life and literature, are so many elements of power, and, without this broad basis of a common ground from which to move the minds of others, the student of a special science, though possessed of the lever of Archimedes that would move the world, has no place whereon to stand.

In accordance with these principles, the object of the system of college education in America has always been development and discipline of character, and the broad preparation of the student for his subsequent special or professional pursuits. Our colleges may not have succeeded in realizing this ideal, nevertheless this has been their ideal; and it is the right one, as much to-day as ever. Whatever changes are required in our institutions of learning, to adapt them to the necessities of the modern era, must be changes in accordance with this principle—changes of means, not of ends, so far as colleges are concerned.

That changes are required is admitted on all hands. It is admitted that the physical sciences should be introduced to primary and preparatory schools; that they should be taught for the double purpose of mental discipline and of mental acquirement in the class-rooms of our colleges; that in teaching them the scientific, inductive, experimental, instead of the dogmatic, method should be pursued; and, finally, that either connected with our colleges, or standing outside of them, schools of thorough scientific and technical special training are imperatively required. It is to inaugurate the wider activity of such a school that we are met here to-day, and I shall say a few words concerning the relation of this school to Lafayette College, on the one hand, and to technical education and the needs of the present time in technical departments on the other hand.

While we trust that in time to come scientific investigation will be promoted in no mean degree by this school and its graduates, it must be confessed that at the present time its object is chiefly the preparation of young men for practical pursuits involving the applications of

science. Nor can it be fairly said that this department is inferior in dignity to the pursuit of abstract science, so called. It is out of the ranks of the practical workers that those peculiarly gifted in scientific investigation are likely to arise; and it is in the ranks of practical workers that they must look, chiefly, for appreciation and support. It is no derogation from the value of a discovery of truth, to say that it can be made useful to man; and, hence, there is no inferiority in the position of those who make it useful to man.

Indeed, that which the whole world chiefly needs to-day, and our country not less than any other, is the application of scientific truths and principles already known to the affairs, and labors, and problems, of daily life. We might even afford to pause in our career of fresh discoveries, to consolidate the progress and utilize the results already obtained. But the alternative is not presented; it is not necessary or best that any part of the intellectual activity of the age should pause; the advance of science itself assists, and is assisted by, the applications of science.

We need a scientific in the place of a barbarous or scholastic architecture; a scientific in the place of a traditional agriculture; a scientific in the place of an empirical engineering; we need more machinery, more economical applications of power, more effective processes of metallurgy and manufacture, more exact knowledge, in all these particulars, of our own condition and necessities, and of the degree in which these can be supplied by experience already attained abroad. Lesoinne, a distinguished French writer, defines metallurgy as "the art of making money in the treatment of metals." This definition may be applied to almost all occupations of life. The practical art of each is not only to achieve certain results, but to do so profitably, to make money in doing so; that is to say, to increase the value of the raw materials, whether wood, or cotton, or ores, or time, or ideas, by the use we make of them, and the transformation to which we submit them, so as thereby to really elevate the condition of humanity: to leave the world better than we found it. This is, in its last analysis, the meaning of honestly making money. Men are put into this world with limited powers and with limited time to provide for their own sustenance and comfort, and to improve their condition. A certain portion of these powers and this time is required for the support of life in a greater or less degree of comfort, and with more or less multiplied means and avenues of enjoyment, activity, and influence. Whatever their labor produces more than this, is represented by wealth, and for purposes of exchange by money. To make money honestly, is to do something for other men better or cheaper than they can do it for themselves; to save time and labor for them; in a word, to elevate their condition. It is in this sense, greatly as we Americans are supposed to be devoted to making money, that we need to learn how to make more money; how to make our labor more fruitful; how

to assail more successfully with our few hands the natural obstacles and the natural resources of a mighty continent; how to build up on the area of that continent a prosperous nation, united in varied, fruitful, and harmonious industries, glowing with patriotism and inspired by religion.

In this work we need specially the basis of a more thorough technical institution, applying principles of science to the material and economical problems involved. This education is necessary to supply the directing forces for the great agricultural, manufacturing, and engineering improvements of the country. It is also needed as a solvent and remedy for the antagonism between labor and capital. The true protection of labor will be found in its higher education, and in opening to the individual laborer for himself and for his children, by means of that education, a prospect of indefinite improvement and advancement.

In the realm of metallurgical and engineering operations the difference between theoretical and practical training is, perhaps, still more striking. The student of chemistry in the laboratory cannot be made acquainted with many of the conditions which obtain in chemical and metallurgical operations upon a larger scale. All the chemists of the world failed to comprehend or to describe correctly the apparently simple reactions involved in the manufacture of pig-iron, until, by the genius and enterprise of such men as Bell, Tanner, and Akerman, the blast-furnace itself, in the conditions of actual practice, was penetrated and minutely studied. Moreover, in all the experimental inquiries of the laboratory the question of economy plays no part. It is the art of separating and combining substances which the student follows there, not the art of making money. That education of judgment and decision, of choice of means for ends which the exigencies of daily practice give, cannot be imparted in the school.

In mechanical engineering the same principle is illustrated. The highest department in this art is that of construction, and in this department the highest function is the designing of machinery. Now, the most perfect knowledge of the theory of a machine and its mathematical relations, of the strength of materials, or the economical use of power, will not suffice to qualify a man to design a machine or a system of machines, for the reason that in this work an element must be considered not at all included in theoretical knowledge, namely, the element of economy in the manufacture, as well as in the operation of the machine. A machine, any part of which requires for its manufacture a tool (such, for instance, as a peculiar lathe) which is not already possessed by the manufacturer, and which, after the construction of this one part, would not be necessary or useful for other work—such a machine could not be profitably built. In other words, machines must be so designed, in a large majority of cases, as not to necessitate the construction of other machines to make them; and the

planning of machinery, so that it shall be at once economical and durable in operation, and simple and cheap in construction, is not merely an important incidental duty, it is absolutely the chief and most difficult duty of the mechanical engineer.

---

## PREPARATIONS FOR THE COMING TRANSIT OF VENUS.

THE nature of a transit of one of the inferior planets (Mercury or Venus) is well understood, and the phenomena attending such a transit have been thoroughly discussed, and fully described in many places. The importance of the observation of these transits, and the general character of the results expected from the expeditions sent out to observe them, are probably understood by all, but it is thought that a brief account of the means that are to be employed to accomplish the desired end will be of interest.

The records of the plans which have been formed, and of the preparations which have been made by the different governments of the world and by private individuals, are, unfortunately for the general public, published only in proceedings of scientific societies, or in many cases they exist only in manuscript. When the expeditions return home after the observations are made, in astronomical Europe and America will resound the busy hum of preparation, and from the beginning of 1875 the reader of astronomical items will be sated.

At first will come a series of preliminary reports as the parties come in; then we shall have the final reports, giving numbers, data, descriptions of instruments, and the observations made at the transit, the longitudes and latitudes of the various stations, and, in short, every result which the practical astronomer will have derived.

These final reports will be eagerly looked forward to, for upon them depends the constant of solar parallax, and from them will be deduced the definitive result of all the astronomical work done on the globe on that day.

We know already that the final outcome of all these vast preparations which we are going to describe will be a number very near to  $8''.848$ .

The whole world is united in an effort to know exactly how to change this; whether to write it greater or less. But the results of these expeditions, if they are successful (and we can hardly fail of success), will be, not simply the establishing of the earth's distance from the sun on a certain basis, but much more.

So many expeditions of trained scientific observers will bring back with them data only second in importance to the main object of their



journeys. The latitude and longitude of many of the almost unknown islands of both oceans will be established with a certainty as great as the corresponding coördinates of most seaports on our own Atlantic coast. Observations for magnetic constants will be made at places widely separated, and much will be learned in this way. The line of Russian stations, and the American station in Siberia, will be connected by telegraphic wires to St. Petersburg, and possibly the stations in the Indian Ocean may likewise be joined with New York or Washington, so that independent longitude determinations by telegraph may be extended over seven-eighths of the globe.

Americans should not forget that our own Coast Survey has made three independent determinations of transatlantic longitude in the years 1867, 1870, and 1873, nor should they forget the wonderful agreement of the results obtained over three different cables, by different observers at different times. This agreement is so marvelous (considering the independence of the determinations), that the results are here quoted :

*Longitude of Harvard College Observatory, west of Greenwich Observatory.*

Campaign of 1867 .....	4 <sup>h</sup> 44 <sup>m</sup> 31 <sup>o</sup> 00
Campaign of 1870 .....	4 44 31.05
Campaign of 1873 .....	4 44 30.99
Mean .....	<u>4 44 31.01</u>

It must be remembered also that, incidentally as it were, the relative longitude of Paris and Greenwich Observatories was found : so that it is to American astronomers, working by a method of American invention, that the exact value of so important a coördinate is due.

Americans will have reason to be proud if equally exact determinations can be extended by them from the Indian Ocean to New York, and from Siberia to Greenwich.

These are only some of the incidental advantages which it may be hoped will be gained by the various expeditions for which the different governments have provided.

There are various ways in which the observation of the transit of Venus may be made, and, in order to describe the instruments, and the preparations which are making, it will be necessary to refer to these briefly :

1. There is *the method of contacts*, which consists in determining the time at which the limb or edge of Venus's disk is tangent to the limb of the sun. To make this observation, a small equatorial telescope is needed, provided with suitable colored glasses to protect the observer's eye, and with the usual appurtenances.

2. The *micrometric method*, which consists in measuring the distance apart of the bright horns of that part of the edge of the sun which Venus partly obscures as she is moving on or off. As Venus has a sensible diameter (about one minute of arc), it will take a sen-

sible time for her disk to move from *first contact* (when her disk just touches the disk of the sun *exteriorly*) to *second contact* (when her disk is tangent *interiorly* to the sun's), and during this time the appearance of the two disks will be as in the figure :

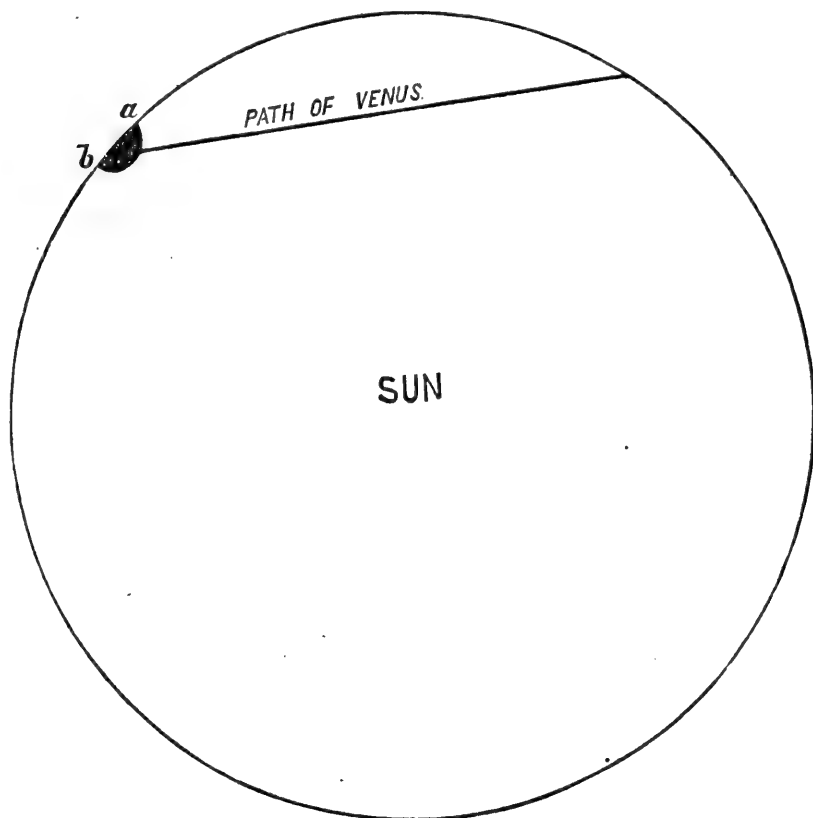

This figure shows Venus coming on to the sun's disk, and it shows the two cusps at *a* and *b*. It will be easily seen that, if we know the length of the line *ab*, and the time at which it has this length, we can calculate the time of contact from these data. So that a number of measures of the cusps is the same as a *number* of first contacts. The reverse phenomenon occurs when Venus passes off the sun's disk.

To measure these distances, the equatorials must be provided with filar micrometers, i. e., with a contrivance by means of which two spider-lines in the focus of the telescope may be moved toward or away from each other. One of these lines is to be placed at *a*, and the other at *b*; the time is to be noted, and the number of turns and parts of a turn of the screw which moves the lines is to be noted from the head of the screw, which is finely divided.

3. The *photographic method*. This consists in photographing the planet Venus on the disk of the sun, and noting the time of each photograph. The negatives are carefully preserved, and are measured subsequently by a fine measuring engine. It will be seen that this method is like the preceding, except that the measuring may be done

at leisure, and without the hurry and anxiety which attach to any observation of this nature.

This method requires apparatus of a special kind. The American plan is to throw the image of the sun, with the planet on its disk, into a stationary photographic telescope where the negative is taken. This is taken out, and at once developed by the photographers, into whose dark room the telescope penetrates. This method is due to Prof. Winlock, of Harvard College Observatory. The other method consists in making the photographic telescope follow the sun in its motion by means of clock-work, and in taking the negatives in the same way. The dark room, however, is some distance off, and it appears that too much dependence must be placed on the steadiness of the clock-work motion.

4. The *heliometric method*. This consists in measuring the cusps with a heliometer, which is merely a large telescope which has two object-glasses (or one object-glass cut into halves by a diametral cut) which slide past each other. Each half produces a complete image, and, by means of an observation of a tangency of images, the distance of the cusps may be had.

5. The *spectroscopic method*. In brief, we may explain this as follows: It is known that there is a thin layer of atmosphere near the sun's limb where bright lines may be seen with a powerful spectroscope, while on either side of this layer dark lines only are seen. As Venus advances, the interposition of her dark body will cut off this layer, and the instant of disappearance of the last vestige of any one of these bright lines will be truly the instant of first contact.

The ordinary method of observing first contact is open to grave uncertainties (on account of the different sensitiveness of the eyes of various observers, and for other reasons), and it is hoped that this method, as beautiful in theory as it will be difficult and delicate in practice, will obviate all these objections.

It is to be expected that the astronomers of the different nations will adopt different plans of observations, in accordance with the peculiar traditions of each school.

The Germans and Russians, among whom the use of heliometers has been hitherto confined, will (with a single exception) alone use them on the approaching transit.

The German Government will send one of these instruments to the Kerguelen Islands, or to Macdonald Island, one to the Auckland Islands, one to the Mauritius, and one to China (Chefoo). Lord Lindsay, of England (the one exception spoken of), also takes a heliometer with his very completely-equipped private expedition to the Mauritius.

Three of the twenty-seven Russian stations in Russia, Siberia, China, and Japan, will be provided with heliometers; at three, likewise, will the photo-heliograph be used, while the remainder of the stations will be devoted to the ordinary contact observations and to measures of cusps.

At all the American stations the photo-heliograph, the contact method, and the method of cusps, will be used. The American stations will be eight in number. These will be principally in the southern latitudes, in the Indian and Pacific Oceans, except one in Siberia, and, perhaps, a photographic station in the Sandwich Islands.

Stations in Japan and China will be established also by the Americans.

Most of the English parties are to be in northern stations, though the Challenger exploring expedition is instructed to examine eligible stations in the South Pacific. Of the stations of French observers little is definitely known, although they will occupy a few posts.

Each party must be provided with instruments to observe the actual transit, and it must further have the means of determining accurately *time, longitude, and latitude*.

Of these *quæsitæ*, the latitude and the local time are most easily determined. Portable transit-instruments will suffice for the first determination, and for the second there are various adequate means.

The American parties are each to be provided with a small portable transit-instrument and zenith-telescope combined, which instruments are now making by Stackpole, of New York.

These are intended to be of the simplest possible construction and of the greatest attainable stability, and they combine several advantages. In accordance with a suggestion first proposed by Steinheil, of Munich, the tube proper of the telescope will be reduced to one-half of the usual length. A prism will be placed at the end of the tube opposite the object-glass, by which the rays which enter the telescope will be turned at right angles through the perforated axis of the pivots of the instrument, thus utilizing the necessary length of this axis by making it an integral part of the telescope.

The observer will thus occupy one position, no matter to what part of the meridian his telescope is pointed, which is, in itself, a great advantage, on the score of convenience. This also will doubtless conduce to a constant personal equation, as it has been shown by the director of the Albany Observatory, and others, that personal equations vary with the altitude of the observed star.

These instruments are provided with fine spirit-levels and with micrometers, which fit them to be used as zenith-telescopes, and thus to determine two of the three important *quæsitæ*.

The parties of other nations will use similar methods for this purpose. The coördinate which is most difficult of exact determination is the longitude, and the problem of its determination will be attacked in various ways.

The English parties, true to the traditions of Greenwich, are to be provided with portable altitude and azimuth instruments with which to observe moon transits, both in the meridian and out of it. A long series of such moon-culminations was observed between Harvard Col-

lege Observatory and Greenwich some years ago, and it is now known that the result obtained was greatly in error. Indeed, Prof. Peirce, in his discussion of the series of observations, came to the conclusion that it was impossible to derive the longitude of a place by this means, *certainly*, within one second of time.

The Americans and Russians intend to depend on the occultations of small stars by the moon.

Occultations are much more likely to be free from systematic errors than the moon-culminations, and, if they can be observed throughout a lunation, a compensation of errors will obtain.

The Russians intend to mask their stations of observation, and subsequently to connect by telegraph St. Petersburg with the most important of them. The transportation of chronometers to and fro between the stations whose longitude is thus determined and the minor ones will assure the longitude of the latter.

The American parties in the southern seas will be transported to their various stations in a ship-of-war which will touch at the different islands and leave the parties, and which will make chronometric expeditions between the various stations. Besides this, all existing telegraph-lines will be utilized. As each of the parties of each nation is to be led by some astronomer of eminence, it is certain that no means will be neglected to make the preliminary results of the greatest attainable accuracy.

The various assistants are now in training at Greenwich, Poltava, and Washington, with the very instruments which they will use on the expeditions.

At Washington and Poltava an apparatus for the representation of the transit is in use. A disk representing Venus is caused to travel over an illuminated space which is representative of the sun, and the circumstances of the transit are then observed.

In this way it is hoped to obtain an idea of the personal error of each observer in watching contacts, so that, in reducing the observations of the transit, all personality may be eliminated.

Most of the American parties will start in the spring of 1874, and proceed in the most expeditious way to their stations. They must take with them *every thing* which they can need during their stay, for in most of the stations there is no supply of any kind to draw upon.

We can hardly realize the absolute necessity of being provided with every thing that *may be* needed on such an expedition: but let us conceive the feelings of an astronomer on a desert island with no screw-driver, or with no ink, or matches, or soap!

There is no repairing a blunder of outfitting in these cases, and the greatest care has to be exercised in providing for all contingencies.

Arrived at its station the party will put up its observatory, a little wooden or canvas hut which has been brought from America, for no

wood grows on *this* island. The instruments must next be mounted, and all gotten in readiness for work.

The astronomer and his assistant set up the transit, the small equatorial (five inches' aperture, and about seven feet long), and the clock, and provide safe places for their chronograph and chronometers. Suppose a chronometer-spring breaks now: there is no help nearer than New York. The two photographers put up their hut and prepare for work. From this time until the time of the transit, *all* is work.

Every day the methods which will be adopted on the important day are rehearsed. Each one does the very thing which he will do, takes the very steps which he must then take, and turns the very same micrometer-screws just as he will turn them in December. This is repeated until every one is sick of it, and, from a man, each becomes a machine.

During the nights the chief astronomer is looking for occultations, or taking differential measures between the moon's limb and a star, while the assistant is determining time and latitude. Sometimes their work is interchanged, to eliminate any personal peculiarities of observing. When the final day comes, they should have their latitude and longitude thoroughly well known, and their clocks and chronometers rated perfectly. The photographers, too, should know the exact strength of both, the precise time of exposure, and the right developer to make the best possible negative of the sun.

When the time of transit actually comes, the chief will be at the equatorial, and will observe the first contact, and record the time on his chronograph, and at once commence measures of the distance of cusps. The assistant astronomer will see that the heliostat which is to throw the image of the sun into the stationary photographic telescope does this properly; and within the dark room the two photographers must be taking negatives as rapidly as possible.

This continues during the transit from first to second contacts; afterward the photographs succeed each other, but not so rapidly, and finally, the last contact is marked. It is all over now, and there is nothing to do but to write down at once all notes which are to be used in the report, and to prepare for a journey home.

Six or eight months on a rocky island, vast expense, and much trouble and discomfort: but *le jeu vaut la chandelle*. The moral of it is, that Science expects every man to do his duty. Let us hope that Science will not be disappointed.



## THE PRIMARY CONCEPTS OF MODERN PHYSICAL SCIENCE.

BY J. B. STALLO.

III.—*The Assumption of the Essential Solidity of Matter.*

IT cannot have escaped the notice of the attentive reader of the passage quoted in my last paper from Prof. Tyndall's lecture on "The Use of the Scientific Imagination" that Tyndall urges the theory of the atomic constitution of matter as the only theory consistent with its objective reality. He takes it for granted that the alternative lies between the definite, tangible, solid atom on the one hand, and a shadowy abstraction—a "vibrating, multiple proportion, or a numerical ratio in a state of oscillation"—on the other. There is no doubt that the opinion thus expressed is shared by the great majority of physicists, as well as of ordinary untrained men. To the minds of most persons, as to the mind of Tyndall, the conception of matter involves the notion of definite, tangible, and indestructible solidity. It is the general tacit assumption that, of the three molecular states, or states of aggregation, in which matter presents itself to the senses—the solid, the liquid, and the gaseous—the last two are simply disguises of the first; that a gas, for instance, is in fact a group or cluster of solids, like a cloud of dust, differing from such a cloud only by the greater regularity in the forms and distances of the particles whereof it is composed, and by the fact that these particles are controlled in the case of a gas by their mutual attractions and repulsions, while in the case of the cloud of dust they are under the sway of extrinsic forces. And, while the transition of the three molecular states into each other in regular and invariable order is too obvious to be ignored, it is supposed that the solid is the primary, normal, and typical state of which the liquid and gaseous, or aëri-form, states are simply derivatives, and that, if these states are considered as evolved the one from the other, the order of evolution is from the solid to the vapor or gas. In this view the solid form of matter is not only the basis and origin of all its further determinations—of all its evolutions and changes—but it is also the primary and typical element of its mental representation and conception.

While this view of the relation between the molecular states of matter is all but universally prevalent, it is not difficult to show that it is in irreconcilable conflict with the facts of scientific experience. All evolution proceeds from the relatively Indeterminate to the relatively Determinate, and from the comparatively Simple to the comparatively Complex. And (confining our attention, for the moment, to the two extreme terms of the evolution, the solid and the gas, and ig-

noring the intermediate liquid) a comparison of the gaseous with the solid state of matter at once shows that the former is, not the end, but the beginning of the evolution. The gas is not only comparatively indeterminate—without fixity of volume, without crystalline or other structure, etc.—but it also exhibits, in its functional manifestations, that simplicity and regularity which is characteristic of all types or primary forms. Looking, *first*, to the purely physical aspect of a gas—I speak, of course, only of gases which are approximately perfect, to the exclusion of vapors at low temperatures and of gases which are readily coercible: its volume expands and contracts inversely as the pressure to which it is subjected; its velocity of diffusion is inversely proportional to the square root of its density; its rate of expansion is uniform for equal increments of temperature; its specific heat is the same at all temperatures, and, in a given weight, for all densities and under all pressures; the specific heats of equal volumes of simple and incondensable gases, as well as of compound gases formed without condensation, are the same for all gases of whatever nature, and so on. In all these respects the contrast with both the liquid and solid forms, the relations of whose volumes, or structures, or both, to temperature and to mechanical pressure or other force are complicated in the extreme, is great and striking. But this contrast becomes still more signal, *secondly*, under the chemical aspect. We cannot, in any proper sense, assign the proportions of volume in which the combination of solids and liquids takes place—indeed, the combination of solids as such is impossible—and the numbers expressive of the proportions of the combining weights upon their face exhibit an appearance of irrelatation and irregularity which the most sustained endeavors of scientific men (such as Dumas, Strecker, Cooke, L. Meyer, Mendelejeff, and Baumhauer) have been unable to obliterate. In the combination of gases, on the contrary, all is simplicity and order. “The ratio of volumes, in which gases combine, is always simple, and the volume of the resulting gaseous product bears a simple ratio to the volumes of its constituents”—such is the law of the combination of gaseous volumes known as the law of Gay-Lussac. By weight, the ratio of combination between hydrogen and chlorine is 1 to 35.5; by volumes, one volume of hydrogen combines with one volume of chlorine (the volumes being taken, of course, at the same pressures and temperatures) so as to form two volumes of hydrochloric acid. Oxygen and hydrogen combine in the proportion of 16 to 2 by weight; but one volume of oxygen combines with two volumes of hydrogen, forming two volumes of watery vapor. Nitrogen and hydrogen, whose atomic weights, so called, are 14 and 1 respectively, combine in the simple ratio of one volume of nitrogen to three volumes of hydrogen, the combination resulting in two volumes of gaseous ammonia. And carbon, whose ‘atomic weight’ is 12, though it cannot be actually obtained in gaseous form, is assumed by all chemists (for reasons not necessary to

state here) to combine with hydrogen in the ratio of one volume to four, so as to yield two volumes of marsh-gas.

It seems to be evident, then, that the typical and primary state of matter is, not the solid, but the gas. And, this being so, it follows that the molecular evolution of matter conforms to the law of all evolution in proceeding from the indeterminate to the determinate, from the simple to the complex, from the gaseous to the solid form. This is no longer a mere presumption; if the nebular hypothesis, so called, after being stripped of its non-essential features, is recognized as a true theory—as it is by all the prominent physicists of the day since the recent revelations of the spectroscope—the gaseous form of matter, in fact, precedes the liquid and solid forms in the order of Nature, and the solid is not the initial, but the concluding term of material evolution. Inasmuch, therefore, as the explanation of any phenomenon consists in the exhibition of its genesis from its simplest beginnings, or from its earliest forms, the gaseous form of matter is the true basis for the explanation of the solid form, and not conversely the solid for the explanation of the gas.

From the foregoing considerations I take it to be evident that the true relation between the molecular states of matter is the exact reverse of that universally assumed. The universality of this assumption, however, indicates that it is not due to a mere chance error of speculation, but to some natural bias of the mind. The question arises, therefore: What is the origin of this prevalent delusion respecting the constitution of matter? I believe the answer to this question to be exceedingly simple, and important in proportion to its simplicity. There are certain fallacies to which the human intellect is liable by reason of the laws of its growth which I propose to call *structural fallacies*, one of which is that the intellect tends to confound the order of the genesis of its ideas respecting material objects with the order of the genesis of these objects themselves. It is well known that the progress of our knowledge depends upon analogy—upon a reduction of the Strange and Unknown to the terms of the Familiar and Known. In a certain sense it is true, what has been often said, that all cognition is recognition. “Man constantly institutes comparisons,” says Pott (“*Etymologische Forschungen*,” ii., 139), “between the new which presents itself to him, and the old which he already knows.” That this is so is shown by the development of language. The great agent in the evolution of language is metaphor—the transference of a word from its ordinary and received meaning to an analogous one. This transference of the name descriptive of a known and familiar thing to the designation of an unknown and unfamiliar thing typifies the proceeding of the intellect in all cases where it deals with new and strange phenomena. It assimilates these phenomena to those which are known; it identifies the Strange, as far as possible, with the Familiar; it apprehends that which is extraordinary

and uncommon in terms of that which is ordinary and common. But that which is most obvious to the senses is both the earliest and most persistent presence in consciousness, and thus receives the stamp of the greatest familiarity. Now, the most obtrusive form of matter is the solid, and for this reason it is that form which is first cognized by the infant intellect of mankind, and thus serves as the basis for the subsequent recognition of other forms. Accordingly we find that, on the early stages of human history, the solid alone was apprehended as material. It was long before even atmospheric air, obtrusive as it was in wind and storm, came to be known as a form of matter. To this day words signifying wind or breath—*animus, spiritus, geist, ghost*, etc.—are the terms denoting that which is the fundamental correlate of matter, even in the languages of civilized nations. And it is very questionable whether either the ancient philosophers or the mediæval alchemists distinctly apprehended any æriform substance, other than atmospheric air, as material. It is certain that up to the time of Van Helmont, in the latter part of the sixteenth and the first decades of the seventeenth century, æriform matter was not the subject of sustained scientific investigation.

It is obvious, then, that, while the progress of evolution in Nature is from the æriform to the solid state of matter, the progress of the evolution of knowledge in the minds of men was conversely from the solid to the æriform; and, as a consequence, the æriform or gaseous state came to be apprehended as a mere modification of solidity. For the same reason, the first form of material action which was apprehended by the dawning intellect of man was the interaction between solids—mechanical interaction—and from this, again, it followed that the difference between the solid and the gas was apprehended as a mere difference of distance between the solid particles, as produced by mechanical motion.

Again: familiarity, in the minds of ordinary men, is universally confounded with simplicity. And, the explanation of a phenomenon consisting, as we have seen, in an exhibition of its genesis from its simplest beginnings, the mind, in its attempts to explain the gaseous form, naturally retraces the steps in the evolution of its ideas concerning matter—of its concepts of matter—back to the earliest, most familiar, and therefore apparently simplest form in which matter was and is apprehended, and assumes the solid particle, the *atom*, as the ultimate fact, as the primary element for all representation and conception of material existence.

This is not the place to develop the important consequences which flow from the total subversion of the prevailing concepts respecting the constitution of matter that, in my judgment, is inevitable. When it comes to be fully realized that an æriform body is not a group of absolute solids, but is elastic to the core; that a gas is a gas throughout, and in its very essence; that in the simplest states of matter there

is no absolute residuum which is exempt from all change and remains constant amid all variation—when the relation of primordial matter to its structural, or rather formative, agencies is properly understood—the whole science of molecular statics and dynamics will press at once for thorough reorganization.

It may be proper, in this connection, before I proceed to the discussion of another topic, to say a few words about the ordinary mechanical explanation of the molecular states of matter, or states of aggregation, on the basis of the atomic theory. This explanation proceeds on the assumption that the molecular states are produced by the conflict of antagonistic central forces—molecular attraction and repulsion—the preponderance of the one or the other of which gives rise to the solid and gaseous forms, while their balance or equilibrium results in the liquid state. The utter futility of this explanation is apparent at a glance. Even waiving the considerations presented by Herbert Spencer (“First Principles,” p. 60, *et seq.*) that, in view of the necessary variation of the attractive and repulsive forces in the inverse ratio of the squares of the distances, the constituent atoms of a body, if they are *in equilibrio* at any particular distance, must be equally *in equilibrio* at all other distances, and that their density or state, therefore, must be invariable; and, admitting that the increase or diminution of the repulsive force, *heat*, may render the preponderance of either force, and thus the change of density or state of aggregation, possible: what becomes of the liquid state as corresponding to the exact balance of these two forces in the absence of external coercion? The exact balance of the two opposing forces is a mere mathematical limit which must be passed with the slightest preponderance of either force over the other. All bodies being subject to continual changes of temperature, the equilibrium can at best be but momentary; it must of necessity be of the most labile kind. If the mechanical explanation of the molecular states were valid, all bodies would present the phenomena exhibited by arsenic under the action of heat—they would at once pass from the solid into the gaseous form, the intervening liquid state vanishing after the manner of all limits.

The notion of the essential solidity of matter of necessity leads to—indeed, at bottom, is identical with—the assumption of its absolute hardness or unchangeability of volume, and thus involves the theory of the atomic constitution of matter in its ordinary form. This assumption is connected with another fallacious bias of the mind, which results from the inability of the mind to consider phenomena otherwise than singly, and under some one definite aspect—the tendency to assign absolute limits to every series of material phenomena. It has been a favorite tenet, not only of metaphysicians but of physicists as well, that reality is cognizable only as absolute, permanent, and invariable, or, as the metaphysicians of the sixteenth and seventeenth centuries expressed it, *sub specie æterni et absoluti*. This proposition, like

so many others which have served as pillars of imposing metaphysical structures, is the precise opposite of the truth. All material reality is, in its nature, not absolute, but essentially relative. All material reality depends upon determination; and determination is essentially limitation, as even Spinoza well knew. A "thing in and by itself" is an impossibility. And I may add here (without dwelling upon it further, a discussion of this subject being foreign to my theme), the "thing *per se*" is not only impossible, according to the *criteria* of our intellect, but it is not the object of knowledge, in any sense, and cannot, therefore, be the legitimate subject of speculation. As Ferrier would say, we can neither know it nor be ignorant of it. I do not speak here merely of objects without relation to the intellect, in the sense of Ferrier's "Theory of Ignorance," but of objects without relation to each other. "We only know any thing," justly says John Stuart Mill ("Examination of Sir W. Hamilton's Philosophy," i., 14), "by knowing it as distinguished from something else; all consciousness is of difference; two objects is the smallest number required to constitute consciousness; a thing is only seen to be what it is by contrast with what it is not." Here, again, the doctrines of psychology are corroborated by the teachings of the science of language. "Words," says Rev. Richard Garnett ("Philological Essays," p. 282), "express the relations of things; and this, it is believed, is strictly applicable to every word in every language, and under every possible modification."

Among those who have had occasion of late to insist upon the relativity of all objective reality is Prof. Helmholtz. Speaking of the inveterate prejudice according to which the qualities of things must be analogous to, or identical with, our perceptions of them, he says ("Die neueren Fortschritte in der Theorie des Sehens," Pop. wiss. Vortraege II., 55, *et seq.*): "Every property or quality of a thing is in reality nothing else than its capability of producing certain effects on other things. The effect occurs either between connatural parts of the same body, so as to produce differences of aggregation, or it proceeds from one body to another, as in the case of chemical reactions; or the effects are upon our organs of sense and manifest themselves as sensations such as those with which we are here concerned (the sensations of sight). Such an effect we call a 'property,' its reagent being understood without being expressly mentioned. Thus we speak of the 'solubility' of a substance, meaning its behavior toward water; we speak of its 'weight,' meaning its attraction to the earth; and we may justly call a substance 'blue,' under the tacit assumption that we are only speaking of its action upon a normal eye. But, if what we call a property always implies a relation between two things, then a property or quality can never depend upon the nature of one agent alone, but exists only in relation to and dependence on the nature of some second object acted upon. Hence, there is really no sense in talking of properties of light which belong to it absolutely, indepen-



dently of all other objects, and which are supposed to be representable in the sensations of the human eye. The notion of such properties is a contradiction in itself. They cannot possibly exist, and therefore we cannot expect to find any coincidence of our sensations of color with qualities of light."

The fundamental truth which is implied in these sentences is of such transcendent importance that it is hardly possible to be too emphatic in its statement, or too profuse in its illustration. All quality is relation; all action is reaction; all force is antagonism; all measure is a ratio between terms neither of which is absolute; every objectively real thing is a term in numberless series of mutual implications, and its reality outside of these series is utterly inconceivable. A material entity, absolute in any of its aspects, would be nothing less than a finite infinitude. There is no absolute material quality, no absolute material substance, no absolute physical unit, no absolutely simple physical entity, no absolute constant, no absolute standard either of quantity or quality, no absolute motion, no absolute rest, no absolute time, no absolute space. There is no physical thing, nor is there a real or conceptual element of such a thing, which is either its own support or its own measure, and which abides either quantitatively, or qualitatively, otherwise than in perpetual change, in an unceasing flow of mutations. An object is large only as compared with another which, as a term of this comparison, is small, but which, as a term in a comparison with a third object, may be indefinitely large; and the comparison which determines the magnitude of objects is between its terms alone, and not between any or all of these terms, and an absolute standard. An object is hard as compared with another which is soft, but which, in turn, may be contrasted with a third still softer; and, again, there is no standard object which is either absolutely hard or absolutely soft. A body is simple as compared with the compound into which it enters as a constituent; but there is, and can be no physically real thing which is absolutely simple. Similarly, all changes of position or distance between two bodies are wholly relative, and it is a matter of purely arbitrary determination, which of them is taken as being at rest, and which as in motion. It is equally true to say that the earth falls toward the apple, and that the apple falls toward the earth.

I may observe, in this connection, that not only the law of causality, the persistence of force, and the indestructibility of matter, have their root in the relativity of all objective reality—being, indeed, simply different aspects of this relativity—but that Newton's first and third laws of motion, as well as all laws of least action, so called, in mechanics (including Gauss's law of movement under least coercion), are but corollaries from the same principle. And the fact that every thing is, in its manifest existence, but a group of relations and reactions, at once accounts for Nature's inherent teleology.

The truth that all our knowledge of objective reality depends upon the establishment or recognition of relations, has been proclaimed by innumerable thinkers, but, nevertheless, is constantly lost sight of, or ignored. There is nothing more interesting and instructive, than a review of the errors and perplexities that have been entailed by the rejection or disregard of this truth both upon metaphysical speculation, and upon physical science. The ontological vagaries spun from the proposition that all reality is in its last elements absolute, do not, of course, concern us here; there is, however, one form of this proposition which is so intimately connected with the main subject under discussion, that it is, perhaps, well to indulge in a passing allusion to it.

Leibnitz places at the head of his "*Monadology*" the principle that there must be simple substances, because there are compound substances. "*Necesse est,*" he says, "*dari substantias simplices quia dantur compositæ.*" This enthymeme, though it has been long since exploded in metaphysics, is still regarded by many physicists as proof of the real existence of absolutely simple constituents of matter. Nevertheless, it is obvious that it is nothing but a vicious paralogism—a fallacy of the class known in logic as fallacies of suppressed relative. The existence of a compound substance certainly proves the existence of component parts which, *relatively to this substance*, are simple. But it proves nothing whatever as to the simplicity of these parts in themselves.

Among the most notable intellectual hobbles resulting from the attempt to deal with quantity as an absolute, self-determining entity are the various theories of infinitesimals in mathematics, and of the real basis of the differential and integral calculus. The consideration of these theories is beyond the limits of my task, which restricts me to the discussion of questions relating to physical science. But within these limits, it is by no means difficult to find conspicuous proof of the fact that the supposed physical constant of weight and volume, the "atom," is by no means the only absolute real term—the only finite infinitude—which is postulated by physical science in its most recent forms. How completely the minds of modern physicists are under the control of the conceit that physical entities, for purposes of their real apprehension, can be disentangled from the net-work of relations as a part of which they present themselves both to thought and to sense, is at once seen upon the most cursory examination of the remarkable speculative writings which have been published of late by eminent scientific men. I select from the many lectures and essays of this class which have fallen under my notice, a lecture delivered November 3, 1869, in the *Aula* of the University of Liepsic, by Dr. C. Neumann (Professor of Mathematics at the university, and well known as the author of several important contributions to the theory of Abel's Integrals), "On the Principles of the Galileo-Newtonian Theory."<sup>1</sup> The

<sup>1</sup> "Ueber die Principien der Galilei-Newton'schen Theorie. Akademische An-

first part of this lecture is without special interest for us here ; but the second part is of the greatest possible significance as an exhibition of the tendency of physicists to postulate determinate last elements, absolute spatial limits, and invariable physical standards in the construction of material phenomena. For this reason, I shall take the liberty of reproducing, as literally as is possible in a translation, the most important passages of this part of the lecture.

“The principles of the Galileo-Newtonian theories,” says Prof. Neumann (*loc. cit.*, p. 11), “consist in two laws—the law of inertia proclaimed by Galileo, and the law of attraction added by Newton. . . . A material point, when once set in motion, free from the action of an extraneous force, and wholly left to itself, continues to move in a straight line so as to describe equal spaces in equal times. Such is Galileo’s law of inertia. It is impossible that this proposition should stand in its present form as the corner-stone of a scientific edifice, as the starting-point of mathematical deductions. For it is perfectly unintelligible, inasmuch as we do not know what is meant by “motion in a straight line,” or, rather, inasmuch as we do not know that the words “motion in a straight line” are susceptible of various interpretations. A motion, for instance, which is rectilinear as seen from the earth, would be curvilinear as seen from the sun, and would be represented by a different curve as often as we change our point of observation to Jupiter, to Saturn, or another celestial body. In short, every motion which is rectilinear with reference to one celestial body, will appear curvilinear with reference to another celestial body. . . . .

“The words of Galileo, according to which a material point left to itself proceeds in a straight line, appear to us, therefore, as words without meaning—as expressing a proposition which, to become intelligible, is in need of a definite background. *There must be given in the universe some special body as the basis of our comparison, as the object in reference to which all motions are to be estimated ;* and only when such a body is given, shall we be able to attach to those words a definite meaning. Now, what body is it which is to occupy this eminent position? Or, are there several such bodies? Are the motions near the earth to be referred to the terrestrial globe, perhaps, and those near the sun, to the solar sphere? . . . .

“Unfortunately, neither Galileo nor Newton gives us a definite answer to this question. But, if we carefully examine the theoretical structure which they erected, and which has since been continually enlarged, its foundations can no longer remain hidden. *We readily see that all actual or imaginable motions in the universe must be referred to one and the same body.* Where this body is, and what are

trittsvorlesung gehalten in der Aula der Universität, Leipzig, am 3. November, 1869. Von Dr. C. Neumann, ord. Professor der Mathematik an der Universität, Leipzig,” etc. Leipzig, B. G. Teubner, 1870.

the reasons for assigning to *it* this eminent, and, as it were, sovereign position, these are questions to which there is no answer.

*“It will be necessary, therefore, to establish the proposition, as the first principle of the Galileo-Newtonian theory, that in some unknown place of the universe there is an unknown body—a body absolutely rigid and unchangeable for all time in its figure and dimensions. I may be permitted to call this body ‘THE BODY ALPHA.’ It would then be necessary to add that the motion of a body would import, not its change of place in reference to the earth or sun, but its change of position in reference to the body Alpha.”*

“From this point of view the law of Galileo is seen to have a definite meaning. This meaning presents itself as a second principle, which is, that a material point left to itself progresses in a straight line—proceeds, therefore, in a course which is rectilinear in reference to the body Alpha.”

It will be observed that the assumption which underlies all this reasoning of Prof. Neumann is that, to conceive motion as real, it is necessary to conceive it as absolute—an assumption in every respect analogous to that of Prof. Tyndall, according to which the reality of matter implies its constitution from absolute, unvarying elements. The logical parentage of the body Alpha is precisely the same as that of the “atom.” And I may add that the assumption of Prof. Neumann is the tacit assumption of almost all the physicists and philosophers of the day, although it is not usually developed to its last consequences. It is one of the tasks of Herbert Spencer, for instance, to exhibit the contradictions involved in the essential relativity of motion. “A body impelled by the hand,” says Spencer (“First Principles,” chap. iii., § 17), “is clearly perceived to move, and to move in a definite direction: there seems at first sight no possibility of doubting that its motion is real, or that it is toward a given point. Yet it is easy to show that we not only may be, but usually are, quite wrong in both these judgments. Here, for instance, is a ship which, for simplicity’s sake, we will suppose to be anchored at the equator, with her head to the west. When the captain walks from stem to stern, in what direction does he move? East is the obvious answer—an answer which for the moment may pass without criticism. But now the anchor is heaved, and the vessel sails to the west with a velocity equal to that at which the captain walks. In what direction does he now move when he goes from stem to stern? You cannot say east, for the vessel is carrying him as fast toward the west as he walks to the east; and you cannot say west, for the converse reason. In respect to surrounding space, he is stationary, though to all on board the ship he seems moving. But now are we quite sure of this conclusion? Is he really stationary? When we take into account the earth’s motion round its axis, we find that, instead of being stationary, he is traveling at the rate of 1,000 miles per hour to the east; so that neither the

perception of one who looks at him, nor the inference of one who allows for the ship's motion, is any thing like the truth. Nor, indeed, on further consideration, shall we find the revised conclusion much better. For we have forgotten to allow for the earth's motion in its orbit. This being some 68,000 miles per hour, it follows that, assuming the time to be mid-day, he is moving, not at the rate of 1,000 miles per hour to the east, but at the rate of 67,000 miles per hour to the west. Nay, not even now have we discovered the true rate and the true direction of his movement. With the earth's progress in its orbit, we have to join that of the whole solar system toward the constellation Hercules; and, when we do this, we perceive that he is moving neither east nor west, but in a line inclined to the plane of the ecliptic, and at a velocity greater or less (according to the time of the year) than that above named. To which let us add that, were the dynamic arrangements of our sidereal system fully known to us, we should probably discover the direction and rate of his actual movement to differ considerably even from these. How illusive are our ideas of motion is thus made sufficiently manifest. That which seems moving proves to be stationary; that which seems stationary proves to be moving; while that which we conclude to be going rapidly in one direction turns out to be going much more rapidly in the opposite direction. And so we are taught that what we are conscious of is not the real motion of any object, either in its rate or direction, but merely its motion as measured from an assigned position—either the position we ourselves occupy or some other. *Yet in this very process of concluding that the motions we perceive are not the real motions, we tacitly assume that there are real motions.* In revising our successive judgments concerning a body's course or velocity, we take for granted that there is an actual course or an actual velocity—we take for granted that there are fixed points in space with respect to which all motions are absolute; and we find it impossible to rid ourselves of this idea. *Nevertheless, absolute motion cannot even be imagined, much less known. Motion, as taking place apart from those limitations of space which we habitually associate with it, is totally unthinkable.* For motion is change of place; but, in unlimited space, change of place is inconceivable, because place itself is inconceivable. Place can be conceived only by reference to other places; and, in the absence of objects dispersed through space, a place could be conceived only in relation to the limits of space; whence it follows that in unlimited space place cannot be conceived—all places must be equidistant from boundaries that do not exist. Thus, while we are obliged to think that there is an absolute motion, we find absolute motion incomprehensible."

I have quoted this elaborate exposition from the text of Mr. Spencer, because it most clearly evinces the difficulty experienced even by those who habitually insist upon the relativity, not only of all our actual knowledge, but also of all our possible cognition, in freeing

themselves from the prejudice that nothing can be real which is not absolute.

Prof. Neumann is not content with showing, or attempting to show, that the reality of motion necessitates its reference to a rigid body unchangeable in its position in space, but he seeks to verify this assumption by asking himself the question what consequences would ensue, on the hypothesis of the mere relativity of motion, if all bodies in space, except one, were annihilated. "Let us suppose," he says (*loc. cit.*, p. 27), "that among the stars there is one which consists of fluid matter, and which, like our earth, is in rotary motion around an axis passing through its centre. In consequence of this motion, by virtue of the centrifugal forces developed by it, this star will have the form of an ellipsoid. What form, now, I ask, will this star assume if suddenly all other celestial bodies are annihilated?"

"These centrifugal forces depend solely upon the state of the star itself; they are wholly independent of the other celestial bodies. These forces, therefore, as well as the ellipsoidal form, will persist, irrespective of the continued existence or disappearance of the other bodies. But, if motion is defined as something relative—as a relative change of place of two points—the answer is very different. If, on this assumption, we suppose all other celestial bodies to be annihilated, nothing remains but the material points of which the star in question itself consists. But, then, these points do not change their relative positions, and are therefore at rest. It follows that the star must be at rest at the moment when the annihilation of the other bodies takes place, and therefore must assume the spherical form taken by all bodies in a state of rest. A contradiction so intolerable can be avoided only by abandoning the assumption of the relativity of motion, and conceiving motion as absolute, so that thus we are again led to the principle of the body Alpha."

This reasoning of Prof. Neumann is irrefutable, if we concede the admissibility of his hypothesis of the destruction of all bodies in space but one. But the very principle of relativity forbids such an hypothesis. The annihilation of all bodies but one would not only destroy the *motion* of this one remaining body and bring it to rest, as Prof. Neumann sees, but it would also destroy its very *existence* and bring it to naught, as he does not see. A body cannot survive the system of relations in which alone it has its being; its *presence or position* in space is no more possible without reference to other bodies than its *change of position or presence* is possible without such reference; and, as I have abundantly shown, all properties of a body are in their nature relations, and imply terms beyond the body itself. The case put by Prof. Neumann is thus an attestation of the truth that the essential relativity of all physical reality implies the persistence both of force and of matter, so that his argument is a demonstration, not of the falsity, but of the truth of the principle of relativity.



As there is no Unconditional in subjective thought, so there is no Absolute in objective reality. There is no absolute system of coordinates in space to which the positions of bodies and their changes can be referred; and there is neither an absolute measure of quantity, nor an absolute standard of quality. *There is no physical constant.*

---

## A POWDER-MILL EXPLOSION.

BY WILLIAM AIKMAN.

I PROPOSE to have a talk about an explosion of a powder-mill. It has never been my hap to see one described, and it has seemed to me that an account of an occurrence of this sort, which does not come under common observation, might not be uninteresting.

While explosions are not the final cause of powder-works—that is, while they are not built expressly for the purpose of exploding—yet they are located with reference to it. It was the fortune of this writer to reside for a number of years within a few miles of the powder-manufactories of the Messrs. Dupont, of Delaware, and so had opportunities of observing the thing of which he speaks. These works will probably be a fair example of others.

These powder-mills, perhaps the most extensive in the country, are about three miles above the city of Wilmington, on the banks of the Brandywine River. The position was selected, some fifty or more years ago, by the father of the present proprietors. It is one of the most beautiful in this whole land. The river flows through an exquisite valley, where at every step some new beauty of wood and hill enchants the eyes.

The powder-works are placed at wide intervals for perhaps a half mile along the banks. They are so secluded and hidden that they are never seen or known to be there by an ordinary or uninformed traveler. Should you be riding along one of the hilly and beautiful roads near the mills, you would not only find nothing to suggest their proximity, but could only by inquiry discover the roads that lead to them.

The elder Dupont, father of the late illustrious Admiral Dupont, was a man of remarkable energy and business ability. In nothing did he show his character and foresight more than in the selection of the location of these mills. During the administration, or after it, of President Jefferson, Dupont came to this country from his native France with the purpose of establishing a manufactory of gunpowder in some favorable location. He found his way to Virginia, and made the acquaintance of Jefferson, who cordially welcomed him to the hospitalities of Monticello.

Anxious to promote the prosperity of that noble State, Jefferson urged upon Dupont Virginia as the place where his contemplated works should be established, and detained him with the courtesies of his home until he could exhibit to him the capabilities and attractions of the country.

Dupont accepted the invitation, and willingly and carefully examined the various places brought under his notice. After a few weeks of inspection and exploration, he reluctantly informed Jefferson that he could not see his way clear to settle in Virginia.

"Is it that the country is not favorable?" asked his entertainer.

"No," was the reply; "it is magnificent."

"Cannot favorable locations be procured? Is not water-power abundant? Cannot materials be found?"

"Yes, yes, but I do not like one thing that I find here."

"But what is that?"

"It's your institution of slavery. I cannot settle where it will be around me."

So Dupont came north, and the powder-manufactories were not established in Virginia.

The city of Paterson, near New York, was then a small village, with its glorious falls of the Passaic not utilized to death as they are to-day, and without a manufactory of any importance within its precincts. Dupont was freely offered a location there, and was strongly inclined to accept it. Every thing was favorable; the position of the land, the unbounded facilities of water-power, ease of transportation, accessibility to a large city, all pointed out the desirableness of the locality; but the sagacious man declined all offers.

"I see," said he, "that this beautiful spot will not remain many years as it is now. Before long, a city or town will grow up just here; extensive manufactories, attracted by this unlimited supply of water, with so many feet of fall, will line the banks of this river. When that time comes, the inhabitants will not brook the presence of a powder-mill, and I, after years of labor, and when all my works are established, will be compelled to move off and away. I must find some place where I can reasonably hope to remain undisturbed."

The secluded banks of the Brandywine, in Delaware, invited him, and the works were erected in its quiet valley.

The tract of land first purchased was large, occupying both banks of the river. It has, in the lapse of years, been gradually increased in size. The Duponts never sell, but are always ready to buy land which lies in their vicinity. The same policy which shaped the action of the father has been continued by the sons—to acquire a property so extensive that no neighboring proprietor can be near enough to desire the removal of their works or be injured by their proximity. This they have accomplished. The country, for perhaps a mile on either side of the Brandywine River, is in their possession, and no one

has a residence, except by their consent, within the possibility of harm from an explosion in their works.

Thus, while such explosions are more or less frequent, the detonation of one of them, if it be not of special violence, excites only the passing remark of a dweller in the neighboring city of Wilmington, and never injures any one outside the works.

Not only is the general location selected, but the various buildings of these powder-manufactories are placed, in reference to the ever-present danger of an explosion. The works are not connected with one another in one great building, or in a connected series of buildings. They are built along the river-banks for over half a mile on either side, and with so much of distance between them that an explosion in one does not ordinarily communicate itself to another, and its destructive effects do not extend beyond the immediate vicinity of the building in which it occurred.

The buildings themselves are constructed carefully with reference to these accidents. They—at least those where the process of manufacture reaches the stage of danger—are built of stone, with three massive walls of solid masonry some ten or twelve feet thick. The fourth side, that which looks toward the river, is made of light framework. The roof is constructed as simply as possible, and is laid upon the walls, and not built into them.

The design of this method of construction may be readily seen. If an explosion occurs, the boarded roof and side of the building readily yield, and are blown into the river, while the massive walls of the other three sides withstand the shock. The building is like a huge mortar. By this additional precaution, the lateral effects of the explosion are prevented, and the buildings on either side are measurably protected.

These precautionary measures, however, are not always effectual. As a general thing—for explosions of greater or less violence are not infrequent—a single dull, heavy detonation is heard, and it is almost unnoticed by those residing in the neighborhood. If slight, it may readily be taken for the noise of a blast in the quarries near by. As, in certain stages of the manufacture, the machinery is set in motion, and the workman leaves the room when the danger is most imminent, life is not necessarily lost by the accident. The only harm that has occurred is the loss of the simple machinery, the materials, and the lighter portion of the building.

Sometimes the case is very different. I have a very vivid remembrance of one. It was the first and the most severe of which I had any experience.

I was sitting with some friends in the parlor of my house, at about eleven o'clock in the morning, when there came a sudden jar and a fearful shock of some very heavy body falling, as I thought, upon the piazza, which ran along the rear of the house. I started from my

seat and toward the door, to see what had happened there, but had scarcely risen when another concussion and a mighty detonation came. I supposed that a very heavy piece of artillery had been discharged in the street, just in the rear of the house. Before I could reach the door, but a few feet away, there came another detonation and another terrific jar, which shook, as the others had done, the house to its foundations. The three reports were in such rapid succession as to be almost simultaneous, but thought was quicker than they, and leaped from supposition to supposition in an instant. The last concussion dissolved my doubts as to the origin of those that had preceded it, and I at once looked in the direction in which I knew the powder-mills to lie.

A spectacle of exquisite beauty and sublimity met my eyes, which will abide in my memory forever. I can hardly expect to convey to the reader the impression which it made upon me. Towering in the heavens, sharply defined against the deep-blue sky, was a column of dazzling white, perhaps a mile in height, and a thousand feet in diameter. Its sides were evenly cut and in perfect symmetry through the whole length of the marvelous column, till they spread out on either side at the top in a broad, palm-like canopy. The mid-day sun was shining upon it, and lighting it up with an unearthly splendor, while it seemed to stand almost over us. We gazed awe-struck and entranced upon it, and could easily think of that pillar of cloud that, in the olden time, stood in its awful majesty in front of the camp of Israel.

It was so vast that it seemed close at hand, although it was three miles away. We watched it silently till it slowly changed its form, and gradually drifted in great cumulous clouds away. It was a vision of singular and glorious beauty, such as I never expect to see again.

In this instance three buildings had been destroyed. The shock of the explosions was exceedingly marked and peculiar, different from any thing that I had previously known. It had a sort of pervasive character that suggested the cause as being immediately at hand. My first impression was not of something at a distance, but rather of the jar of a heavy body falling within four or five feet of where we were sitting, and, when it was repeated, of a cannon discharged close by the house. It seemed to be underneath and all around—to fill the very earth and air.

This pervasive character of the shock is very remarkable. It is the same in all that I have heard. It seems to be felt scarcely more violently in the immediate vicinity of the place where it occurred than miles away. In this case we were between three and four miles off, and yet the explosion could scarcely have been more startling and severely felt, or have seemed nearer, to those who were within a few rods of the place. Indeed, on certain occasions, the violence of the shock is felt much more at a distance than close at hand. In one instance that I

remember, the detonation and concussion were felt and heard distinctly and severely in Philadelphia and in Chester County, Pennsylvania, some thirty miles away, while they were scarcely noticed in Wilmington.

The sound and shock of these explosions must be strikingly similar to those of an earthquake. A few years since—it was on the very day that Chicago was burning—a severe shock of an earthquake was felt in Wilmington, Del., and its vicinity. It is described to me, by those who experienced it, as peculiarly alarming. The concussion was terrific, shaking the houses, opening doors, disturbing furniture, and the boom of the report was exceedingly loud and startling. In an instant all instinctively sprang to their western windows, and almost at once on every accessible roof spectators were gazing toward the northwest, the direction in which the Dupont powder-works are situated. The universal impression was, that there had been an explosion of unusual violence at those works. It was only when, after a time, no column of smoke was seen to rise, that any other explanation was suggested. The noise and the concussion were precisely like what had often been heard before on such an occasion.

The pervasive character of the sound and the shock in both the earthquake and the explosion of a powder-magazine are probably due to the same cause. They are propagated along the line of rocky strata. A continuous stratum of rock extends from the Brandywine to Philadelphia and its neighborhood, and this gives an obvious explanation to the fact, to which allusion has already been made, that the detonation and concussion are heard quite as distinctly as, and sometimes more so, at a distance, than, at a point nearer at hand.

I was curious to witness the effects of an explosion at the place where it occurred, so I set out at once for it. A great concourse was thronging the avenue leading toward the powder-mills, and dotting the fields which lay between them and the city. There was no time to be lost in hiring a vehicle; so, giving some specimens of tall pedestrianism, learned of yore in the streets of New York, I was soon in advance of the crowd, and, in company with a young and wiry Scotchman, whom I could not outwalk, was over the beautiful hills and through the woods which skirt the Brandywine, and at the place.

It was difficult, indeed, as I think of it now after some years, quite impossible, to realize what had taken place not an hour before. The day was at its noon, and the lovely valley was sleeping in quiet beauty. All was perfectly still, with nothing to suggest the terrible occurrence, except it might be those two or three rounded heaps yonder, over which a white canvas sheet was thrown. Under them lay the poor mutilated remains of what a little while ago were stalwart men. It was not good for loved one or stranger to look upon them now!

What struck me more than any thing else was the peculiar air of cleanliness and order that was over the place. Every thing, trees,

stones, road-bed, were all blackened, but all were smoothly swept. It seemed as if some time before there had been a fire which had blackened every thing, and that some one had gone round afterward, and, carefully gathering up and conveying away all the *débris*, had scrupulously swept the whole with brooms, leaving only the soot-stains behind.

Nothing of the sort had been done. Here was simply the result of the storm that had a little while before swept the spot. Usually, the force of the explosion is so great that no *débris* can be left behind. It is simply hurled out of existence. There are no broken boards or pieces of shingle, or bits of wood, to be found. They vanish in an instant. The ground itself has a singularly smoothed appearance, as if beaten down and rounded off.

There were few questions to be asked. On these occasions the proprietors and workmen are reticent, and information is not readily accessible. Indeed, inquiries as to the cause of the explosion are generally useless. If it has been through the agency of a careless workman, he is not there to tell the tale. The man nearest, and most acquainted with the fact, is probably the one who in an instant passes out of life, often totally vanishes from human sight, not even a fragment of his body remaining behind.

That many of these accidents are caused by the carelessness of workmen, there can be no doubt. It is needless to say that the utmost precaution is taken to guard the safety of the men and the works, such as floors flooded with water, shoes in which only copper nails are used, etc. The reader will perhaps smile when we say that *smoking* is absolutely prohibited. Yet, incredible as it may appear, the authority of the proprietors is absolutely necessary to enforce this prohibition. A proprietor of a powder-mill once said to me, that in the face of the ever-present danger, and of the most positive orders, it was impossible to prevent the men, at times, from taking their lighted pipes into the works; that he had detected the men thrusting their lighted pipes into their jacket-pockets to escape observation, as he had unexpectedly come upon them! A triumph of art—to smoke one's pipe in a powder-mill, and "the boss not find it out!"

Once in a while, on some special occasion, the pipe of some such cunning fellow goes suddenly out, and he with it. He does not linger to tell how it happened.

It might be supposed that it would be extremely difficult to find men in sufficient numbers to carry on a business so hazardous, in which the workman's life is in such constant danger. But no such difficulty is experienced. There are always more applicants than places for them to fill. As in every business, however unpleasant or unwholesome, there will always be found men who are more than ready for the work.



## SKETCH OF J. D. HOOKER, F.R.S., LL.D.

AMONG the scenes of interest near London which earliest attract the foreign visitor, is the magnificent Botanical Garden at Kew. It occupies 300 acres, which are crowded with the wealth of the vegetable kingdom, and forms the most extensive and perfect horticultural establishment in the world. It has three museums, containing upward of 50,000 objects of rare scientific interest exquisitely arranged, the completest botanical library ever yet brought together, a series of ample and admirably-constructed hot-houses, a pinetum, a water-lily aquarium, an extensive and richly-stocked arboretum, fern-houses, both tropical and temperate, an orchid-house, a house for begonias and gesneracea, together with a variety of other greenhouses and extensive plots of ground covered with herbaceous plants, and beautified to perfection. Kew Garden is one of the most popular places of resort in England. Some 700,000 people visit it annually, and the least educated of all this multitude cannot pass through it without learning something. The exotic plants nurtured in the hot-houses; the indigenous and naturalized plants blooming in the gardens; the dried specimens preserved in the herbarium; the various objects of curiosity treasured up in the three museums of economic botany—vie with each other in claiming the attention of even the most indifferent observer.

Learned philosophers and young children can equally find there abundant objects replete with interest for each, and worthy of lengthened contemplation: one loiters to examine curiosities of vegetation, such as the inner bark of "traveler's joy" (*Clematis vitalba*), used by the Swiss as a vegetable sieve for straining milk; or the inside of the towel-gourd, used in the West Indies as a sponge or a scrubbing-brush. There is an orange-tree, such as in the island of St. Michael produces 20,000 oranges in a year. Here is the caricature-plant, with the whimsical variegation of its leaves; the telegraph-plant, with the jerking of its lateral leaflets like the signals of the old semaphore; the tuberose, exhaling the most delicious perfume, and the stinking carrion-flower of South Africa; the pitcher-plant, each blossom containing half a pint of water and a swarm of drowned insects; and the Venus's flytrap, which springs its toothed leaves together for the capture of gnats and flies. At every turn and nook there are curiosities to excite the observant, and gratify the seeker for systematic, economic, or descriptive botanical knowledge.

Kew has been a place of plants, a nursery or seed-plot for the study of floriculture and horticulture, for more than a hundred years. It was a royal property, being purchased in 1730 by Frederick Prince of Wales, the great-grandfather of the present queen. The original

director of Kew Gardens was William Aiton, who had charge of it for thirty years, and died in 1793. He was succeeded by his son Townsend Aiton, who held the position for forty-eight years, when he resigned in 1841. Up to this time the establishment had been much restricted, but it was now given up by the royal family to the charge of the government, in the interests of science, and for the advantage of the people.

Sir William Jackson Hooker, Professor of Botany in the University of Glasgow, became director in 1841, and he then commenced that wonderful series of transformations which in the course of his twenty-four years' directorship made Kew Gardens the first establishment of its kind in the world; while its character has not only been worthily sustained, but very appreciably expanded, advanced, and elevated, by his son and successor, the subject of the present sketch.

Dr. JOSEPH DALTON HOOKER was born June 30, 1817. He was an only son, and his mother was a woman of ability, who shared in the scientific and artistic reputation of her husband. Educated under the scrutiny of his parents, the subject of this memoir was prepared from the outset for his career as a botanist and a scientific observer. Destined at first for the medical profession, young Hooker took his medical degree at an early age, but, under the influence of his hereditary preference for botany, the profession was given up, and he took to science. His medical education was, however, of great value to him in his subsequent experience both as botanist and traveler.

His first adventure in any public capacity as a botanical inquirer was one that eminently befitted him in his then twofold character of a practitioner of the healing art and as a purely scientific investigator. This was in 1839, when, having but just entered upon his twenty-second year, he took part as assistant-surgeon and naturalist on board the *Erebus* in the expedition sent out, under the command of Sir James Ross, to the Antarctic Ocean. Ostensibly Dr. Hooker's position throughout that memorable voyage was that of a medical officer on one of her majesty's ships-of-war: in reality his especial object all the while was to study the botany of the various regions touched at in those remote portions of the antipodes in the course of the expedition.

It is well to remember that Hooker received, during this four years' voyage, only the moderate pay accruing to him as a medical officer, his outfit being provided by his father, as well as his books and his instruments. Throughout the whole of that period, moreover, Sir William defrayed the expenses constantly incurred by his son when on shore, both in traveling and in collecting, notwithstanding the whole of the fruits of his labor, thus accumulated at considerable cost, were sought out for no private end, but for the advantage of a national establishment. Even after his return homeward, Dr. Hooker magnanimously determined to forego all claim to promotion in the royal navy, devot-

ing four years more to the classification of the treasures he had brought back with him at the close of the expedition. The result of these eight years of toil was visible, in the end, in his splendid publication of the "Flora Antarctica." The comparisons therein drawn of the new plants brought home by Dr. Hooker in great abundance, with the species already familiar to botanists in other parts of the world, helped apparently to realize to naturalists the laws, hitherto but dimly conjectured, regulating the distributing of plants over the surface of the globe.

Prior to entering upon the second of his many memorable expeditions of research as a botanical collector, Dr. Hooker held the position of botanist to the geological survey of Great Britain. On his return homeward, Dr. Hooker gave to the world, in 1851, as the literary fruits of his long journeyings, the two important volumes of his "Himalayan Journals." The three subsequent years were employed by him in arranging his Indian collection. Immediately upon his coming back, he had, moreover, resumed his labors as an assistant to his father at Kew Gardens. Besides this, for nine years together, beginning with 1851 and ending with 1860, Dr. Hooker was employed by the Lords of the Admiralty in editing a series of publications in which were recounted, in chronological sequence, the various botanical discoveries of a number of notable voyagers, from Captain James Cook down to Dr. Joseph Hooker himself. At intervals during the years thus occupied, he entered upon several other important journeys to different parts of the European Continent, visiting, besides these, at other periods, the north of Africa and the far West of the great Continent of America.

Dr. Hooker, in 1855, received the appointment of assistant-director of the Botanical Gardens, with a salary of £400, without any residence. Sir William Hooker was at that time seventy years of age, and was, therefore, fully entitled to have the assistance of his son thus secured to him by the government. Three years after, he had his salary increased to £500 a year, with use of a residence. His father died in 1865, aged eighty-one.

As an example of industry, during the directorship of the Hookers more than 130 costly volumes, treating upon all branches of botany, have been issued to the world from the Kew establishment. Living plants to the number of between 8,000 and 9,000 annually have, within the same period, from that grand central point of distribution, been sent to various parts of the globe—new and often most precious additions to the treasures of Kew being constantly sought out and brought homeward through the agencies employed by the ever-vigilant directors. The correspondence involved in this constant interchange of communications between them and the botanists of both hemispheres has been such that 40,000 letters, it has been calculated, have, in the course of the comparatively brief interval we are referring to, been

received, and have been answered, nearly every one of them, by the hands of the directors themselves.

The history of science furnishes few instances like this of prolonged devotion to a public enterprise so splendidly carried out as to become a national honor and a benefaction to the scientific world. The development of Kew is a noble work of art requiring genius, taste, enthusiasm and perseverance, as well as knowledge. The world had to be ransacked to accumulate his treasures, and those treasures are for the most part living things. The Hookers, father and son, have not only given a generation of incessant work to the organization of the Kew Gardens, but they have done it at a constant and large self-sacrifice. They contributed effort and money to the perfection of a work which is an honor to the government, and one would think that the least the government could do would be fairly to admit the obligation. But, under the Gladstone administration, the office of Commissioner of Public Works was conferred upon a narrow-minded blockhead named Ayrton, who looked upon science and its interests with the prejudice and contempt characteristic of politicians. His office placed him in charge of the Botanical Gardens as the superior to whom its director was responsible, and he began a course of meddling interference with the affairs of the establishment which was so insulting to Dr. Hooker, and would have been so injurious to the place, that the leading scientific men of England united in a protest to the government. The paper, signed by Lyell, Paget, Huxley, Darwin, and Tyndall, was drawn up by the latter gentleman, and presented the government in such a disgraceful attitude before the world, that Parliament took up the subject and put a check to the offensive treatment of Dr. Hooker by the arrogant and supercilious minister of public works. A man's work must be his monument, and Dr. Hooker may be well content with that; but, after what has taken place, the Government of England owes it to its own dignity to recognize in some fitting way the eminent services of the director of the Botanical Gardens.

Dr. Hooker stands high, not only as an indefatigable explorer, but also as a philosophic botanist; and he long since espoused the doctrine that the species of the world's present flora have been derived by descent and divergent modifications from ancient vegetable forms. He married a daughter of the Rev. J. S. Henslow, Professor of Botany in the University of Cambridge; and his wife is not only herself an accomplished botanist, but she shares in her husband's labors, and has recently translated a splendid work upon the subject from the French language.

## EDITOR'S TABLE.

*A NEW SCIENTIFIC SCHOOL.*

A NEW institution, of great promise, has just been added to our increasing list of scientific and technological schools. Pardee Hall, a spacious and well-appointed edifice, costing \$250,000, and the gift of Mr. Ario Pardee, was added to Lafayette College, at Easton, Pa., with imposing ceremonies of dedication, on the 21st of October. The structure has a front of 256 feet in length, with lateral wings, the centre building being five stories in height. It is constructed of Trenton brownstone, with trimmings of light Ohio sandstone. The lecture-rooms, cabinets, models, laboratories, apparatus, and the facilities for studying mining operations, are on the amplest scale. In chemistry, the establishment is especially strong. Many thousand dollars have been expended for chemical apparatus, much of it made to order in Germany and France; there is desk-room for nearly 250 students, and, by the introduction of the latest improvements, the laboratories are claimed to be the completest in America. It is stated that Mr. Pardee, who is largely engaged in mining operations, has contributed not less than half a million dollars to Lafayette College, which, under the presidency of the Rev. Dr. Cattell, has reached a very prosperous condition.

We publish a portion of Prof. Raymond's able dedicatory address, regretting that we have not space for the whole of it. It will be seen that he takes broad ground, and insists upon a liberal culture for the special students of science. We hope that what he says upon this subject foreshadows the policy of the new institution. The narrowness of the curriculum of our technological schools, which aim, like our business colleges, and like medi-

cal and legal schools, to prepare immediately for practical professional life, is a very serious objection, as it favors the false idea that scientific education has no wider basis than sheer pecuniary utility. That scientific schools, as those of agriculture, mining, and engineering, have hitherto been liable to this reproach, is undeniable. But that is certainly no reason why a course of education that is marked out with predominant reference to professional pursuits should not be at the same time broad and liberal. Allowances, of course, must be made for the difficulties of initiating a new system, which had to answer the question "Of what use?" at the outset. Healthful beginnings are ever small, and it was inevitable that the traditional system, of culture, which ostentatiously repudiated every thing like practical uses, should make the most of the poverty and narrowness of the scientific curriculum. But the first stage in the history of the scientific schools is now past. They have ceased to be experiments; their need is acknowledged, and they are being established on the most munificent scale of endowment. It is now demanded that the "new education" shall be widened, harmonized, and adjusted, so as to meet the full requirements of a liberal mental cultivation. Let the basis of training be modern and scientific, instead of ancient and classical, and, the new standpoint being taken, let the courses of study be widened, so as to include moral, literary, and æsthetic agencies of training. Of course, with the growth of the new, there must be riddance of the old, but the old educational tree has plenty of decayed branches and dead wood, the cutting away of which will reinvigorate its whole life.

## SCIENTIFIC LECTURES.

THAT lectures will always continue to be, as they always have been, a valuable mode of public instruction, there can be little doubt; but, that what is called the lecture system is going to prove an agency of national regeneration, may be seriously questioned. In so far as it is in any sense a system, it has degenerated to a mere catering to public amusements. The platform is crowded with readers, singers, declaimers, dramatists, and buffoons, and the "course of lectures" is transformed into a "series of entertainments." People cannot have their intellects on the rack forever, you know; they must have a little relaxation. This tendency to pander to a low public taste, and, under the respectable name of lectures, to degrade the platform to purposes of mere speculation, ought in every way to be withstood. Let amusements stand upon their own basis, and not appeal to the public under false pretenses. Lectures upon science, history, or philosophy, to be really valuable, should be given in courses with sufficient fullness to produce some depth of impression. It is in this way that such men as Lardner, Mitchell, and Tyndall, have helped on the work of public education. We spoke last month in commendation of Mr. Proctor, as a popular teacher of astronomy; and, to those who desire lectures of a similar first-class character in another and widely-different field, we now recommend Prof. Edward S. Morse, of Salem, Mass. Prof. Morse's department is zoology, in which he is an original investigator, of excellent standing, and therefore thoroughly acquainted with the actual phenomena of his subject. As a teacher of natural history, he has rare merits, a lively and wide-awake manner, by which he keeps the attention of his audience; simple and untechnical language, suited to make everybody understand him; and remarkable skill in the rapid and accu-

rate drawing of diagrams upon the black-board. To most lecturers this is an interruption and a bore. They have to stop speaking while they are drawing, to outline the object they are dealing with. Prof. Morse makes his figures rapidly and elegantly, using both hands at once, and keeps up an unbroken flow of talk. The advantage of being thus able to hold his audience, by engaging two senses at once, is very great; for, not only is he more secure of the listeners' apprehension by creating his forms before the eye at the same time they are described to the ear, but the pleasure of full mental occupation is also in a high degree favorable to the retention of what is learned. It may be added that in this way the lecturer's work is not only of superior quality, but there is a great deal more of it in the same time. Every town where there is a college or high-school, and any serious mental activity, should arrange for a special course of lectures such as Prof. Morse furnishes.

---

"THE STUDY OF SOCIOLOGY."

THE first article this month closes the series of papers upon "The Study of Sociology" that have been running through our pages for a year and a half. We have previously stated the relation of this discussion to Mr. Spencer's other works, but there still remains much misapprehension upon this point, and the present is, therefore, a suitable occasion for a brief restatement of the case. That we are here concerned with the advance of a new division of scientific knowledge of great importance to the public is a further excuse for repetition.

In 1860, Mr. Spencer threw out the prospectus of a system of philosophy which he expected it would take him twenty years to complete. The undertaking was new, comprehensive, and original, as it proposed to construct a system of general philosophy on the



basis of the widest and most recent results of science. From this point of view it was a higher unification of knowledge than had been hitherto attempted; but it was more than this. As the truths and science of Nature have proved in various ways helpful to man in the practical concerns of life, it was the higher object of their systematic statement to arrive at a clearer and more assured guidance in the conduct of human affairs. As the older philosophies disavowed the end of utility, a philosophy which is the outcome of science, and rests upon the established truths of Nature, may claim the service of humanity as its highest end. The scheme was, therefore, so bold an innovation that it found favor with but few. By many it was regarded as an intrinsically impossible undertaking, and by others as a futile endeavor of any one intellect. But Mr. Spencer had well surveyed his ground; and, as the work quietly proceeded, there was soon evidence that the execution was equal to the promise, and that the enterprise had fallen into the hands of one who had a genius for it. As an example, Mr. John Stuart Mill gave his testimony to the encyclopædic scientific preparation of Mr. Spencer for such a work, and at a crisis of the undertaking he came forward and offered to assume the whole pecuniary responsibility of its continuance, on the ground that its failure would be a public calamity. At the same time, the leading organs of British opinion began to concede Mr. Spencer's eminent position and power, as when the *Saturday Review* declared him to be "the greatest organizer of thought that had appeared in England since Newton." It was noteworthy, also, that men of the highest mark who had studied him most thoroughly were the readiest to concede his power, as when Dr. McCosh years ago spoke of his "giant mind," and in his late address before the Evangelical Alliance re-

ferred to him as the Titanic thinker of England.

But from various causes Mr. Spencer's work did not take hold of the general public. All the masterly papers that are now collected in his several volumes of essays had been published anonymously in the reviews, and he was comparatively but little known in the literary world. His form of publication of "The Philosophical System" by subscription was not calculated to attract general readers, while its formidable character repelled many at the outset. As it was supposed to be a destructive system, and its author a dangerous man, the misrepresentations of the press were so gross and malignant that Mr. Spencer refused to furnish his series to them, and was thus cut off from that source of publicity. Yet his subscribers embraced the most thoughtful men of England, and upon many of these he made a strong impression. While the mass of English readers knew nothing about him, students were devouring his works and accepting his views. Calling at the London book-shops for the "works of Spencer," you would be handed the "Faerie Queene," and, when you said "*Herbert Spencer*," the rejoinder would be, "We never heard of him." Yet, at the same time, the serious attention of the House of Lords was called by one of its members to the growing influence of Spencer's ideas in the universities, and even the Premier of England has recently felt it incumbent on him to make a speech to arrest the increasing influence of his opinions.

But this restriction of Mr. Spencer's readers mainly to scholarly circles has resulted in two evils: the first was that other men appropriated his ideas, and, by translating them into popular forms, made reputations for themselves at his expense; and the second was, that the most erroneous and distorted conceptions were formed by the public of the character of the system itself.

Mr. Spencer is perhaps too little concerned for the passing influence of his doctrines, and, except that the heavy expenditure of publication requires to be sustained as it proceeds, he would be content to leave their character to the verdict of the future. But many, believing that his system of thought is of great, immediate, and practical value, were anxious that something should be done to give it a stronger hold upon public attention. Mr. Spencer was therefore urged to suspend for a time his methodical work, and to address a wider circle of readers by the preparation of a small popular volume, and by using the channels of periodical publication.

Moreover, he had reached a stage in the unfolding of his system which was not only favorable to such an episode, but which urgently required it. That which the world will probably regard as the great work of his life, should he be able to complete it, and which is also of the greatest moment to society, is still before him; while all that he has hitherto done is but a preparation for it. This is nothing less than to organize and place upon its proper foundations the science of man's social relations. A dozen years have been occupied in laying the foundation upon which alone the social science can be built. "The Principles of Sociology" is to be his next and great work, and it was felt to be on every account desirable that Mr. Spencer should say something at this time to the reading public on the nature, claims, scope, limits, and difficulties, of this important subject. This he consented to do, and, in the preface to "The Study of Sociology," he admits that he does not now regret it.

And the object proposed has been already in a good degree attained; the articles have been widely reprinted and extensively read. That they will have a large and salutary influence upon public sentiment admits of no

question. The views have been reproduced and commented upon extensively by the press, who have generally recognized their importance, and the need that they should be well understood in a country where all men are government-makers. A marked illustration of the effect of these papers and of Mr. Spencer's tables of "Descriptive Sociology," the first of which is now published, is furnished by the recent inaugural address of Lord Houghton before the British Social Science Congress. The *Times* of October 2d reports him as saying: "Their consideration has impressed me strongly with the uncertain *data* on which all Social Science is founded, and the importance of the connection between Sociology and Biology which Mr. Spencer, both in his philosophical works and in the elaborate tabular statement of social facts which he has supervised, and which I earnestly commend to your notice, is now expounding and illustrating." It was to exert an influence of just this kind that "The Study of Sociology" was prepared. It is hence not to be regarded as a treatise upon sociological science, but rather an introduction to it. It treats of questions which bear upon it, but which Mr. Spencer could not properly deal with in his forthcoming "Principles of Sociology."

---

MEN of science have their discouragements, general and special. The English just now have a spasm of unhappiness because the government will not allow them to accept honors from foreign sovereigns. It seems that the Emperor of Brazil and the King of Sweden are inclined to bestow their marks of favor upon English *savants*, who would be glad to accept them, but a regulation of the Foreign Office, dated 1855, forbids any subject of her majesty to accept a foreign order, or to wear its insignia, without the queen's permission; and it is declared that

“such permission shall not be granted unless the foreign order shall have been conferred in consequence of active and distinguished service before the enemy, either at sea or in the field,” or unless the party “shall have been in the service of the foreign sovereign by whom the foreign order is conferred.” It may be thought that this is a very light cross to bear, but we republicans cannot understand how grave these considerations are in England. Virtue may be its own reward, and wealth, fame, and the honor of making discoveries, may fill the measure of ambition nearly full, but nothing fills out, and sweetens, and happifies the life of the typical Britisher, like a decoration. When, therefore, an appreciative foreign sovereign sends over a bundle of ribbons for distribution among the distinguished F. R. S.’s, it certainly appears hard that they cannot be allowed to wear them. The editor of *Nature* has all our sympathy when he says: “It seems to us unjust and cruel that men of science, to whose labors it is mainly owing that our country and the world generally are mounting rapidly higher and higher in the scale of civilization, should be practically debarred from accepting the few honors that come in their way.”

---

## LITERARY NOTICES.

**THE ATMOSPHERE.** Translated from the French of CAMILLE FLAMMARION. Edited by James Glaisher, F. R. S. With 10 Chromo-Lithographs and 86 Woodcuts. 450 pages 8vo. Price, \$6.00. Harper & Brothers.

A VOLUME like this, summing up our knowledge of the atmosphere, has been long wanted, and it is now well supplied. The scientific investigation of the air may be said to have commenced with the discovery of its weight and the invention of the barometer about 1643, and the eight generations of investigation that have intervened have developed a vast body of facts and laws relating to atmospheric phenom-

ena, so that, considered alone as a measure of what has been done in this period toward clearing up the mysteries of Nature, M. Flammarion’s book would be very interesting. The French edition was twice the size of the present translation, and was a regular cyclopædia of atmology, but, by cutting off certain parts of it which dealt with the remoter relations of the air, as for example its influence upon plants, and by retrenching the exuberant imaginative style in which it was written, and in which popular French writers so delight, the translator has brought the work within very reasonable limits, and adapted it more perfectly to the taste of English readers. The edition has, moreover, gained greatly in accuracy and trustworthiness by the rigorous censorship of its editor, Mr. Glaisher, whose position as a scientific meteorologist is no doubt superior to that of the author of the work. The book is very free from technicalities, and, in its simplicity, accuracy, and attractiveness, it is an excellent example of popular scientific literature. Its general object, as stated by the editor, has been “to produce a work giving a broad outline of the causes which give rise to facts of every-day occurrence in the atmosphere, in such a form that any reader who wished to obtain a general view of such phenomena and their origin would be readily enabled to do so. The great number of subjects treated of will thus, to the majority of readers, who merely desire an insight into the general principles that produce phenomena, which every one has seen or heard of, be found to be rather an advantage, as the whole range of atmospheric action is thus displayed in the same volume in moderate compass, without so much detail being anywhere given as to make the book other than interesting to even the most casual reader.

“The work treats of the form, dimensions, and movements of the earth, and of the influence exerted on the meteorology by the physical conformation of our globe; of the figure, height, color, weight, and chemical components of the atmosphere; of the meteorological phenomena induced by the action of light, and the optical appearances which objects present as seen through different atmospheric strata; of the phenomena connected with heat, wind, clouds, rain,

and electricity, including the subjects of the laws of climate. The contents are, therefore, of deep importance to all classes of persons, especially to the observer of Nature, the agriculturist, and the navigator."

The volume is elegantly executed, and in its whole style is a credit to the publishers.

THE COMPARATIVE ANATOMY OF THE DOMESTICATED ANIMALS. By A. CHAUVEAU, Professor at the Lyons Veterinary School. Second edition, revised and enlarged, with the Coöperation of S. ARLOING, Professor at the Toulouse Veterinary School. Translated and edited by GEORGE FLEMING, F. R. G. S., Veterinary Surgeon, Royal Engineers. 957 pages; 450 Illustrations. Price, \$6.00. D. Appleton & Co.

THE first edition of this comprehensive work appeared in 1854, and it has held a leading place as a text-book in the Continental colleges. It is an exhaustive and exact description of the anatomical machinery of which the bodies of our domestic animals are composed. As the first trait required in such a work is accuracy, Prof. Chauveau could not be satisfied with a compilation, no matter how weighty the authorities; and, although the whole range of anatomical erudition was consulted, the work took its character from the direct study of Nature, the position of the author as anatomical principal in the Imperial Veterinary School affording him the most extensive opportunities of observation and dissection. Moreover, the author aimed at something more than the mere accumulation of an endless and arid mass of anatomical details. He sought the bonds, and relations, and meanings, by which they could be connected and harmonized, in a philosophic method. Inspired by the influence of the two illustrious anatomists, George Cuvier and Geoffroy St.-Hilaire, he thus speaks of their labors:

"The first, after immense researches, ventured to compare the innumerable species in the animal kingdom with each other; he seized their general characters—the analogies which allied them to one another; he weighed these analogies, contrasted them with the dissimilarities, and established among them different kinds and different

degrees; and in this way was he able to form natural groups, themselves subdivided into several categories in which individuals were gathered together according to their analogies and affinities. Then the chaos was swept away, light appeared, and the field of science was no longer obscured; *comparative anatomy* was created in all its branches, and the structure of the animal kingdom was brought within those laws of uniformity which shine throughout the other parts of creation.

"Geoffroy St.-Hilaire followed Cuvier over the same ground. More exclusive than Cuvier, he entirely neglected the differential characters, and allowed himself to be governed by the consideration of resemblances. He especially pursued the discovery of a fixed rule for guidance in the search after these resemblances—a difficult task, and a dangerous reef, upon which the sagacity of his illustrious rival was stranded. To be more certain than Cuvier, and the better to grasp his subject, he restricted the scope of his observations, confining himself more particularly to the class of vertebrata, in order to solve the enigma whose answer he sought. At last he found it, and made it known to us in those memorable though abstruse pages, in which the meaning is often obscure and hidden, but which contain, nevertheless, magnificent hymns chanted to the honor of the Creator. The shape and functions of organs, he says, do not offer any stability, only their relations are invariable; these alone cannot give deceptive indications in the comparison of the vital instruments. He thus founded his great *principle of connections*, firmly established its value, and fortified it by accessory principles. Then was the philosophical sentiment decidedly introduced into the researches in organization, and anatomy became a veritable science."

The new edition of the work has been rewritten throughout, greatly extended, and brought up to the present time; but its method is the same. The two branches of anatomy, human and comparative, are brought into closer alliance, and the comparison of the organs of man with those of animals is made a prominent feature. The work is, therefore, not only a complete dissection-manual for the student of veterinary

science, and a book of reference for the veterinary surgeon, but it is also available for the zoologist, the comparative anatomist, the ethnologist, and the medical practitioner. Although we have had good books on the structure of the horse, this is the first complete treatise on the anatomy of the domesticated animals in the English language, and will contribute materially to the progress of veterinary science, while being useful also to the community at large.

**OUR COMMON INSECTS.** A Popular Account of the Insects of our Fields, Forests, Gardens, and Houses. Illustrated with 4 Plates and 268 Woodcuts. By A. S. PACKARD, M. D. 225 pages. Price, \$2.50. Salem: Naturalists' Agency. Boston: Estes & Lauriat. New York: Dodd & Mead.

DR. PACKARD has done an excellent thing in preparing this little hand-book. His large "Guide to the Study of Insects," with upward of 700 pages and 1,200 figures, although reduced to five dollars in price, is still too expensive for the great mass of readers; and it was therefore well to distill it over, with the contents of the *American Naturalist*, into a more portable and popular form. Good and cheap books on insects require to be multiplied, for we are all interested in them. They infest us inside and out, by day and by night, sleeping and waking, at home and abroad; they damage our food, poison our drink, spoil our clothes, kill our domestic animals, ravage our gardens, blast our fruit, and destroy our crops. The subject cannot be ignored, but we naturally approach it with prejudice. There are, however, compensations in all things. Although insects may be our enemies, they are yet scientifically very interesting creatures. We all have a high opinion of Nature, and are never done praising her; but she runs to insects incontinently—they could outvote all the rest of the animal kingdom five to one. As the higher tribes of life have been perishing out in multitudes along the geological march, it cannot be doubted that the same thing has happened in a much greater degree to the insects, although their vestiges were, of course, more difficult of preservation. But Dr. Packard tells us that there are upward of 200,000 living

species, and, as species are held by many to be immutable, each one having been specially created, we have a clew to the exact number of miracles that these pests have cost: though why miraculous contrivance took such an excessive turn in this direction will perhaps be found explained in Dr. Bushnell's book of "Dark Things." But, however they came, the insects are here, a part of the world of life, growing, multiplying, and dying, like ourselves; undergoing curious transformations, and animated by wonderful instincts—social, industrious, and most instructive in all their ways and history. Dr. Packard selects the most common, those that are easily—often too easily—observed, and gives us their various stories with an interest that is quite romantic. His volume is compact with information upon the subject, and is adapted to all intelligent readers; but, for sensible boys and girls, it is worth a whole library of the fictitious drivel that now forms so large a part of the mental nourishment of the young.

This volume consists mainly of reprinted matter, but it contains a new and admirable chapter entitled "Hints on the Ancestry of Insects." The irrepressible question of origins is not to be escaped, and, as it has long haunted the souls of botanists, it now begins to torment the entomological soul. Insects cannot be studied without being classed, and they cannot be classed without knowing their resemblances and affinities, and these cannot be made out except through their embryological or developmental history. The question how things are runs into the question how they came to be, and the first thesis of Scripture becomes the last problem of science—that is, *genesis*. Dr. Packard inclines to the view that the primal ancestors of insects were worms, and he assumes without hesitation the doctrine of evolution as best explaining the facts of the science. We quote one or two passages upon this point:

"Many short-sighted persons complain that such a theory sets in the background the idea of a personal Creator; but minds no less devout, and perhaps a trifle more thoughtful, see the hand of a Creator not less in the evolution of plants and animals from preëxistent forms, through natural



laws, than in the evolution of a summer's shower, through the laws discovered by the meteorologist, who looks back through myriads of ages to the causes that led to the distribution of mountain-chains, ocean-currents, and trade-winds, which combine to produce the necessary conditions resulting in that shower.

"Indeed, to the student of Nature, the evolution theory in biology, with the nebular hypothesis, and the grand law in physics of the correlation of forces, all independent, and revealing to us the mode in which the Creator of the universe works in the world of matter, together form an immeasurably grander conception of the order of creation and its ordainer than was possible for us to form before these laws were discovered and put to practical use."

Again he says :

"Thus the ovipositor of the bee has a history, and is not apparently a special creation, but a structure gradually developed to subserve the use of a defensive organ. So the organs of special sense in insects are, in most cases, simply altered hairs. The hairs themselves are modified epithelial cells. The eyes of insects, simple and compound, are at first simply epithelial cells, modified for a special purpose ; and even the egg is but a modified epithelial cell attached to the walls of the ovary, which in turn is morphologically but a gland. Thus Nature deals in simples, and with her units of structure elaborates as her crowning work a temple in which the mind of man, formed in the image of God, may dwell. Her results are not the less marvelous because we are beginning to dimly trace the process by which they arise. It should not lessen our awe and reverence for Deity if, with minds made to adore, we also essay to trace the movements of his hand in the origin of the forms of life.

"Some writers of the evolution school are strenuous in the belief that the evolution hypothesis overthrows the idea of archetypes and plans of structure. But a true genealogy of animals and plants represents a natural system, and the types of animals, be they four, as Cuvier taught, or five, or more, are recognized by naturalists through the study of dry, hard, anatomical facts. Accepting, then, the type of articulates as

founded in Nature from the similar modes of development and points of structure perceived between the worms and the crustacea on the one hand, and the worms and insects on the other, have we not a strong genetic bond uniting these three great groups into one grand sub-kingdom, and can we not in imagination perceive the successive steps by which the Creator, acting through the laws of evolution, has built up the great articulate division of the animal kingdom ?"

#### PROPORTIONS OF PINS USED IN BRIDGES.

By CHARLES BENDER, C. E. No. IV.,  
Van Nostrand Science Series, 52 pages.  
Price, 50 cents.

THIS is a very small book, but it would certainly be wrong to measure its importance by its dimensions. In science, we are often told that there is no great and no small, by which it is meant that the interest and value of things in Nature are not dependent upon magnitude. It is desirable, as we all feel at times, that bridges should be well constructed, and, as their parts are held together by pins, all who travel are interested that these pins should be in proper proportions. Thanks to Bender for determining what these proportions are, and to Van Nostrand for diffusing a knowledge of them. We bear our testimony to the importance of the research, and the value of the publication, but we regret to say that we cannot recommend this monograph for popular reading, as it is brimful of mathematics.

#### A TREATISE ON ANALYTICAL GEOMETRY.

By WILLIAM G. PECK, LL. D., Professor of Mathematics and Astronomy in Columbia College, and of Mechanics in the School of Mines. 212 pages. A. S. Barnes & Co.

PROF. PECK has prepared this treatise for the use of his own classes in Columbia College and the School of Mines. His object has been to present the subject in a narrower compass than is done in the usual voluminous works that are employed as text-books in the mathematical departments of the higher institutions. The author puts forward no claims to originality of method, and states that the gen-



eral plan of the work does not differ essentially from that adopted by the earlier writers on the subject; but he has revised definitions, simplified explanations, abbreviated demonstrations, and conformed the limits of the treatment to the growing wants of scientific education.

**CHRONOS: Mother Earth's Biography; a Romance of the New School,** by WALLACE WOOD, M. D. London: Trübner & Co., 1873, 334 pages.

If a peripatetic scientific lecturer may seek to draw listeners by proclaiming to make science "as fascinating as fairy tales," surely the author of this book is justified in terming his work a "Romance of the New School."

In eleven chapters he pictures with a flowing pen the birth, growth, maturity, and decay of Mother Earth; and to those who have puzzled their brains over the severe, concise formulas of Herbert Spencer, who have passed working hours on the nebular hypothesis, and striven with the problem of the precession of the equinoxes, or the data and inductions of Biology and Psychology, it is like sailing with a "wet sheet and a flowing sea" on the highest waves of the imagination over the formidable obstacles which those philosophical problems present.

The author professes to traverse the field with seven-leagued boots, and surely they are needed, for in this small volume is crowded the result of prolonged and profound speculations into the mystery of the earth, its geology, its life, the periods of its development, the evolution of its organisms, its social history, and its final dissolution.

With liberal quotations from the writings of modern scientists, with here and there an enlivenment of humor, and—to deal with him gently—some considerable irrelevant frivolity, he puts forward in a fresh and brisk, if not altogether attractive presentation of the subject, the most advanced ideas of the evolutionists, and those who shudder at the definition of evolution as "a change from an indefinite incoherent homogeneity, to a definite coherent heterogeneity," may, not unprofitably, follow their chatty and lively guide, who certainly is never dull while acting as *cicerone*.

THE first American contribution to the International Scientific Series will be by Josiah P. Cooke, Professor of Chemistry in Harvard College, on the "New Chemistry." It is well known that this science in recent years has undergone a profound change in its theory, with a corresponding change in its nomenclature. The new view is firmly established in the world of science, and modern text-books are slowly adopting it, while the mass of educated people still think in the old chemical ways. A book was needed to make this transition clear and easy for the non-scientific, which should explain the necessity and philosophy of the change more fully than is possible in the regular manuals, and such a work Prof. Cooke has now prepared. He has long taught the modern views, and his College Text-book of "Chemical Philosophy" embodies them; but, perceiving the public want, he prepared a course of lectures familiarly explaining the new doctrines, and delivered them at the Lowell Institute in Boston (immediately after the course of Prof. Tyndall), with great satisfaction to those who heard them. The volume containing these lectures, carefully revised and illustrated, is now going rapidly through the press, and will be ready in a very short time. It will be of interest to general readers who care to note the progress of scientific thought; but will be invaluable at the present time to all teachers of chemistry.

---

#### PUBLICATIONS RECEIVED.

*Acrididæ of North America*, by Cyrus Thomas, Ph. D. (Geological Survey of the Territories.) Washington: Government Printing-Office, 1873.

*Essay on the Glacial Epoch*. By Dr. Philip Harvey. Burlington, Iowa, 1873, pp. 24.

*New Vertebrata from Colorado Territory*. By Prof. E. D. Cope. Government Printing-Office.

*Law and Intelligence in Nature*. By A. B. Palmer, A. M., M. D. Lansing, Mich., 1873, pp. 31.

*Thysanura of Essex County, Mass.*, by A. S. Packard, Jr., with two other papers

by the same author, on the New American Phalænidæ and the Cave Fauna of Indiana.

Seventh Annual Report of the Superintendent of Missouri Public Schools.

Eleventh Annual Meeting of the Missouri State Teachers' Association.

## MISCELLANY.

**The Coal-Fields of China.**—The coal-fields of the Chinese Empire cover an area of 400,000 square miles, and yet China imports large quantities of coal from England. In the great province of Hunan, says *Iron*, a coal-field extends over an area of 21,700 square miles. Hunan boasts of two distinct coal-beds, one bearing bituminous coal, and the other anthracite—the latter being favorably situated for water-transit, covering an area equal to that of the anthracite coal-fields of Pennsylvania, and yielding anthracite of the best quality. The coal-area of the province of Shansi is 30,000 square miles, enough to supply the whole world for thousands of years, even at the present rapid rate of consumption. An immense supply of iron-ore adds to the mineral wealth of this great province.

If it be asked, in view of these facts, why it is that China imports foreign coal, we have only to consider the methods of mining followed by the Chinese, and the want of good roads, in order to get a satisfactory reply. The mode of working, says the writer in *Iron*, is at once tremendously severe and ludicrously ineffectual: the shafts are not perpendicular, but are inclined planes, 400 or 500 feet in length, running down a slant of about 45°. Up this slant the men carry the coal in baskets, one being attached to each end of a short carrying pole, which is borne upon the left shoulder. The shafts are about seven feet high, and about the same width, with a wooden roof, beams on both sides for support, and wood along the floor, so arranged as to form steps, up which the miner pulls himself by catching the projection of a step above him with a small curved staff, which he carries in his right hand. Even with cheap labor, this barbarous method proves expensive.

But the great difficulty is conveyance. The famous canals of the Chinese Empire are

confined to the lower basin of the Yangtze. The roads are simply in a state of nature. Mere lines of deep ruts mark the track of the primitive vehicles of the country. The only repairs are effected by the rains, which wash them level; and then the sun hardens the slushy mass. In some provinces two-wheeled vehicles are employed, but in the central provinces only the primeval wheelbarrow, and in the hilly districts these rude machines give way to beasts of burden. The cost of transportation is, of course, enormous. In the province of Shansi, coal which costs about 25 cents per ton at the mine rises to six dollars at the distance of 30 miles; so that only those who live almost at the pit's mouth derive any benefit from the coal-mines of the Celestial Empire. This difficulty, amounting almost to impossibility of transit, presses with equal weight upon every department of Chinese industry. The crops are splendid, but there are no means of reaching the market, and the apathy produced by the want of means of transit amply explains why famine is a chronic scourge in the land of plenty.

The introduction of a railway system into China would not only enrich the proprietors, but would confer immeasurable benefit on the inhabitants of the country. It has been proposed to tap the great province of Hunan by extending a railway from Upper Burmah to the confines of the Celestial Empire, and there is little doubt that within a few years the shriek of the steam-whistle will be heard within the confines of the "Empire of the Sun and Moon."

**Sericulture in Brazil.**—The Italian newspapers, says *La Nature*, give some interesting information with regard to the measures now being taken in Brazil to forward the production of a silk yielded by a peculiar species of butterfly, which is as yet but little known in that country, and quite unknown in Europe. This butterfly (*Bombyx saturnia*), commonly called the *portaspejos*, has a spread of wings four times as great as that of the common silk-worm moth. The caterpillar feeds on the leaves of the *Ricinus communis* and also of the *Anacardium Occidentale*. The cocoon differs very widely in appearance from the common cocoon. It is enveloped in a bag-

like pellicle, resembling cobweb, which being removed, the cocoon is found to be oval. In color it is grayish, and its tissue differs from that of European cocoons in being wove like a bird's-nest. The caterpillar does not shut itself quite up in the cocoon, but leaves an opening, through which it escapes in the imago-shape.

The *Bombyx saturnia* works rapidly, completing the cocoon in three weeks; in three weeks more it quits it; and thus the silk-harvest takes up only six or seven weeks. The process of filature, or of unwinding the threads of the cocoon, is very simple, the threads, owing to the peculiar structure of the cocoon, being very readily separated from one another by the action of warm water. The fibre possesses considerable strength. One thread, twelve inches long, will bear a weight of sixty-two grains, and a cord of fifty-four threads a weight of over two pounds. The thread, however, is somewhat coarse, but efforts are being made to get it of greater fineness so as to fit it for weaving into fabrics and spinning into sewing-thread. If this Brazilian fibre passes successfully through its period of trial and experiment, it will give the world a very cheap silk, the cost of production being much less than that of European silk. The cocoon is found in great quantities in the north of Brazil. The caterpillar feeds on the tree, and withstands the inclemency of the weather. The tree is so abundant that whole ship-loads of cocoons might be collected.

**The Descent of Man.**—M. Gabriel de Mortillet, at the recent meeting of the French Association, after showing that certain flints found in tertiary strata bear evidences of human workmanship, goes on to prove that this tertiary precursor of man was not identical in species with the man of the present period. "If there is one fact well established," says he, "and admitted by all, it is this: that there is a succession of faunæ from one geological period to another. From stratum to stratum the fauna is modified, the animals change, and these modifications, these changes, are all the more marked in proportion as the strata are wider apart. Between two strata in contact there may exist species in common,

but strata widely separated from one another have different species, and even different genera, in case they lie very wide apart. These changes occur all the more rapidly in proportion as the animals possess a more complicated organization. Thus the mollusca, having a less complicated organization than the mammals, have sometimes a far more protracted existence as species. Certain shells are found identical in two strata, in which the mammalian faunæ are very widely different. These are not mere hypotheses, but scientific data, based on direct observation of facts.

"Now, since the formation of the calcareous strata of Beauce and of the loam-deposit at Thenay, in which chipped flints are found, the mammalian faunæ was completely renewed at least three times. The differences between the mammals of the Beauce limestone and the mammals of the present period are not only sufficient to characterize distinct species, but have appeared sufficient in the eyes of zoologists to warrant their classification into special genera. The mammals of the level of the Beauce limestone and of the Thenay loam all belong, almost without exception, to extinct genera—genera nearly allied to those at present existing, but yet quite distinct from them. How, then, could man, who has a most complicated organization, alone escape the action of this law? We must therefore conclude that, if, as every thing leads us to presume, the Thenay flints bear the evidences of intentional chipping, they are the work, not of the present human species, but of another species of man, possibly even of a genus the precursor of man, which would serve to fill up one of the gaps in the zoological series."

**An Ancient Papyrus.**—The King of Saxony has purchased, and placed in the Leipzig Library, an Egyptian papyrus on the preparation of medicines, which was found at Thebes by Dr. Ebers. It is a beautiful yellow papyrus, in a good state of preservation. It consists of 110 columns, and has written on the back a double calendar in eight columns. Each column is eight inches wide, and contains twenty-two lines. The writing is from right to left; it is all in black ink, except the beginnings of chapters,

which are in red ink. The characters are distinct, bold, and tasteful, and the priest who traced them must have been an artist. Their form, says *La Nature*, from which we gather these particulars, would appear to fix the seventeenth century B. C. as the date of the manuscript; and the fact that in the calendar the name of King Ra-ser-ka (Amenophis I.) is mentioned proves that the papyrus is not posterior to the first half of that century.

The work itself dates from a period more remote than the transcription on papyrus. It is known that the most ancient Egyptian writings were works about medicine. Manetho tells us that the Egyptians honored one of their first kings as a physician. This assertion is confirmed not only by the fragment of papyrus of Brugsh and Chabas, preserved in the Berlin Museum, but also by the present document.

The first chapter of the papyrus treats of the original production of the book, which came from the Temple of On (Heliopolis). Then follow the remedies employed for the cure of various diseases, together with extensive details as to diseases of the eye, remedies against the falling off of the hair, for sores, fevers, the itch, etc. The chapter devoted to the mistress of the house is succeeded by one about the house itself, which insists on the importance of cleanliness, and tells how to banish insects, to exclude them from houses, to prevent serpents from coming out of their holes, to avoid the stings of gnats and the bites of fleas, and to disinfect clothing and dwellings. Then there is a treatise on the relations between soul and body, with secret methods of studying the heart and its movement.

After giving this general description of the papyrus, which he ascribes to the time of the early Pharaohs, very shortly after Menes, Ebers apologizes for not having studied it more profoundly, for the want of literary resources during his travels. But he promises that he will decipher it completely with the aid of his colleagues, though the task is one that will require several years of labor. He hopes that, with the aid of the various translations of the Bible, he will succeed in determining the meaning of the names of certain diseases hitherto unascertained. He will furthermore get assist-

ance from ancient Egyptian writings, from the dictionaries of the Semitic languages, and from some Greek works which are essentially of the same nature as this papyrus, especially from a work by Dioscorides. There occur, according to Ebers, 100 words in the papyrus which are altogether new. Of course it is not expected that the work will throw any light on physiology, pathology, or therapeutics; still, it will be interesting for the information it will supply as to the history of medicine in remote ages.

**The Weeping-Willow.**—The pleasant tradition that made this the tree on which the captives of Sion, at Babylon, hung their harps, has been lately disproved by the investigations of Karl Kock. He shows that the Hebrew word "Garab," used by the poet David, refers to a poplar, and not a willow. This willow, because of the current belief, Linnæus named *Salix Babylonica*. That the tree was not a willow, Ranwolf had concluded long ago. Among systematists the Linnæan specific name will have to give way to that of *Salix pendula* (Mœnch). The hardness of the drooping willow indicates a climate colder than that of Mesopotamia, and it is now regarded as of Chinese or Japanese origin.

**An Ancient Well in Illinois.**—A correspondent, writing from Fulton, Whitesides County, Illinois, gives the following particulars of the discovery of an ancient well in that locality, which he thinks is deserving of further investigation. Some twenty years since, a farmer, living on a high and dry rolling prairie, about sixteen miles from the Mississippi, in Whitesides County, dug a well in his yard. The first five feet dug through consisted of mould and clay, the next twenty-two feet of sand and gravel, and the succeeding five feet of black muck. In the midst of this black earth the remains of an old well were struck, the centre of the new excavation falling within six inches of the centre of the old one. This ancient well was stoned up in a workmanlike manner, the stones, in the opinion of the mason employed, having been laid in a sand-and-lime cement. It was filled with the mucky material composing the stratum in which it was found; and, on clearing out a

portion of this, water in the desired quantity was obtained. The curb of the old well, after the removal of a few of the top stones, was made the foundation of the new curbing, which was carried upward to the surface. The thirty-two feet of earth overlying the old well had never before been turned up.

Our informant, Mr. George M. Woodward, adds that these statements were originally taken down from the lips of the farmer himself, who, though not now living on this farm, is still accessible; and that they are received as facts by all the intelligent old settlers of the vicinity.

**Scientific Prediction verified.**—A striking example of the great accuracy attainable in scientific prediction is found in the history of the Mont Cenis Tunnel. Before the work was commenced, two eminent savants, M. Elie de Beaumont and Signor Sismonda, had expressed the opinion that, in proceeding from France to Italy, the following rocks would be met with: 1. A bed of schist, with anthracite, having a thickness of from 5,000 to 6,500 feet. 2. A bed of very hard quartzite, with a thickness of from 1,300 to 1,900 feet. 3. Compact limestone, with gypsum, anhydrite, and dolomite, having a thickness of from 6,000 to 9,000 feet. 4. A series of calcareous schists, 23,000 to 27,000 feet in thickness. Messrs. Beaumont and Sismonda said that no igneous rocks would be encountered, all the formations in these parts of the Alps belonging to the stratified rock.

Actual experience corresponded very closely with the predictions of science. First, there occurred the schists, with carboniferous sandstones, containing veins of anthracite: thickness, 6,453½ feet. Then the quartzites: thickness, 1,255½ feet. Next, beds of gypsum, anhydrite, and dolomite, with a thickness of 7,726½ feet. Finally, calcareous schists for the remaining 28,323 feet of the tunnel.

**The Brain and the Mind.**—Dr. Burt G. Wilder's paper, before the American Scientific Association, on "Variations in the Cerebral Forms and Fissures of Domestic Dogs," contains some very interesting criticisms of the various methods followed in studying

the relations between brain and mind. There is, first, the phrenological method, wherein the skull is accepted as an index of the brain. But the fallaciousness of this method is shown: 1. By anatomy, in that no definite correspondence whatever exists between folds and fissures of the brain and the outer surface of the skull. 2. By the fact that no phrenologist has ventured to draw the accepted map of the mental faculties on the surface of the brain itself. 3. By the failure, in many cases, of the most expert phrenologists to define character by an examination of the head. The pathological method is equally unproductive of satisfactory results. This method proceeds by comparing brain-lesions with mental phenomena observed during the life of the individual. But the patrons of this method are not yet agreed as to the special function of the cerebellum, nor as to the localization of the faculty of speech. Then, too, there is good reason for supposing that peculiar mental conditions may exist without recognizable brain-lesion, and *vice versa*. Finally, Dr. Wilder asserts, on the authority of Brown-Séquard, that "all parts of the brain may, under irritation, act on any of its other parts, modifying their activity so as to destroy or diminish, or to increase and to morbidly alter it!"

The experimental method proceeds by irritating or destroying certain cerebral regions in living animals. This method satisfactorily demonstrates the existence in the brain of centres of action for different sets of muscles. But, then, it necessarily produces abnormal action, and fails to show the relation between brain and mind. Dr. Wilder then describes his own method, which is, in theory, that of the phrenologists, but differing therefrom in two important respects: 1. In employing the brain itself for comparison, in using large numbers, and in comparing the two sides. 2. In employing canine instead of human brains, on the ground of their simple fissural pattern, and the possibility of an accurate knowledge of the mental characteristics of the dogs. Of course, better results might be expected from the study of the brains of persons with whom we were acquainted in life, but that is impracticable. From the study of a brain, if a criminal or



pauper whom the investigator has never known, nothing can be learned. It is otherwise with dogs, where the brain and the mind of the same individual are at our disposal. It is worthy of remark that Dr. Wilder is no believer in the localization of faculties in different portions of the brain, and is inclined rather to think that a cerebral hemisphere acts as a unit either singly or with its fellow.

**Relics of Man in the Miocene.**—In our June number appeared a note by Sir John Lubbock about the discovery, near the Dardanelles, of an engraved fossil bone, dating from Miocene times, and supposed to furnish evidence of man's existence at a very early geological period. A paper was presented to the American Association, at its late meeting, by Mr. George Washburn, of Constantinople, wherein reasons were given for questioning the value of these remains as evidence of the high antiquity of man. The fragment of mastodon-bone, so called, is described by Mr. Washburn as having 50 marks, more than half of which are grouped in the centre. Taken individually, they are peculiar and puzzling; but, taken together, they can hardly represent the figure of an animal, or show any evidence of design. They may have been produced by worms when the bone was soft. The smooth upper surface of the stratum of limestone on which the bone was found is covered with exactly similar marks, many groups of which make more striking pictures than those found on the bone. One specimen in particular is so marked that a vivid imagination might distinguish the picture of a wild-boar with a spear in his side, with the Greek letter  $\Pi$  most clearly cut by the side of it. As for the split bones found in the same stratum, and the flint fragments, the author satisfactorily accounts for the shapes assumed by these, without supposing the intervention of man.

**The Octopus and its Prey.**—Mr. Henry Lee, of the Brighton (England) Zoological Gardens, wishing to view the seizure of a crab by an octopus, recently fastened one to a string and had it lowered into the aquarium close to the glass, while he watched the operation in front. The crab had hardly

descended to the depth of two feet when an octopus shot out like a rocket from one side of the tank, opened its membranous umbrella, shut up the crab in it, and darted back to its hiding-place. As the animal could not be well observed in this situation, the attempt was made to pull the bait away from him, so as to draw him out of his retreat. But, as soon as the octopus felt the pull, he took a firm grasp of the rock with all the suckers of seven of his arms, and, stretching the eighth aloft, coiled it round the tautened line. Noticing several jerks on the string, Mr. Lee told his assistant not to use too much force. But the man assured him that the jerking was done by the octopus, and that the creature would soon break the line if he did not let it go. "Hold on, then, and let him break it," said Mr. Lee. In three tugs more the line broke, though it was pretty strong twine.

But Mr. Lee's object was to study particularly the animal's mode of seizing and disposing of its prey. Accordingly, a second crab was so fastened that the string could be withdrawn if desired, and was lowered near to the great male octopus. The crab was seized precisely as the observer desired, viz., caught between the octopus and the glass plate. In an instant the prey was completely pinioned. Not a movement, not a struggle was visible or possible—each leg, each claw, was grasped all over by suckers, enfolded in them, stretched out to its full extent by them. The back of the carapace was covered all over with the tenacious vacuum-disks, brought together by the adaptable contraction of the limb, and ranged in close order, shoulder to shoulder, touching each other; while, between others which dragged the abdominal plates toward the mouth, the black tip of the hard, horny beak was seen for a single instant protruding from the circular orifice of the radiation of the arms, and the next had crunched through the shell, and was buried deep in the flesh of the victim. The action of an octopus when seizing its prey for its necessary food is very like that of a cat pouncing on a mouse, and holding it down beneath its paws. The movement is as sudden, the scuffle as brief, and the escape of the victim even less probable. "The fate of the crab," adds Mr. Lee, "is not really more



terrible than that of the mouse or of a minnow swallowed by a perch, but there is a repulsiveness about the form, color, and attitudes of the octopus which invests it with a kind of tragic horror."

**Cooling and Contraction of the Earth's Crust.**—Prof. Dana concludes, in the September number of the *American Journal of Science*, a series of able papers on Dynamical Geology. He states that about 8 per cent. is the average change of density for the earth's crust between the stony and liquid states, which is equivalent to a change of volume from 100 to 92 per cent. This, therefore, expresses the contraction or shrinkage which the crust of the earth undergoes in its transition from a liquid condition to that of stone.

This contraction, as Prof. Dana long since stated, is the source of those inequalities of the surface which have resulted from a bending of the earth's solid exterior. From this cause have arisen the elevation of continents and the basin-like depressions now occupied by the waters of the oceans, and from the same cause mountain-chains have been uplifted.

The origin of the continental elevations and oceanic depressions was when the earth's crust began to form on the fiery liquid mass. Then, from change of density, already noticed, the cooled areas would sink and be overflowed by liquid matter, which, in its turn, would cool. Thus at length a solid and comparatively stable area would result—not elevated as yet, but at the general level of the liquid areas. These would, in their turn, undergo like change of conditions, and a crust, more or less stable, would envelop the globe. This would thicken, by solidifying, underneath the outer shell, as cooling proceeded.

But in thus solidifying it would undergo a change, both of density and volume, and this change would stand for a certain amount of contraction and subsidence. This amount, by the ratio given, would be in depression to an extent of 5,000 feet, if the crust or rocky layers be 12 miles thick. But the ocean-beds will average in depth, below the mean level of the continents, 16,000 feet. In order to effect so great a subsidence, the stony layers must be  $38\frac{1}{2}$

miles in thickness. In the subsidence several subordinate dynamical results must occur. One of these is powerful lateral pressure or thrust of the subsiding mass against the more stable areas, and this thrust might be horizontal, or obliquely upward. A consequence of this pressure would be an elevation or yielding, in some form, of the areas against which the pressure was directed. Possibly both have occurred; certainly the solid crust has bent, until vast mountain uplifts have occurred, and it became fractured to its profound depths.

From this and other considerations it would appear that continental elevations and oceanic depressions were outlined when the crust began to form, and that they have not since entirely changed places.

It further appears that the continents are a growth, in which additions to their margins have occurred. Such is evidently the case with the continent of North America, as shown in its rocks, in its outlines, and the character and results of its oscillations.

**Improved Deep-Sea Sounding Apparatus.**—In the July number of the MONTHLY may be found a description of Brooke's self-detaching shot-apparatus for bringing up specimens of the sea-bottom. This instrument has been considerably improved by Commander Belknap, of the U. S. steamer *Tuscarora*, now engaged in exploring the bed of the Pacific, with a view to find a suitable berth for a submarine cable from San Francisco to Japan, *via* the Aleutian Island chain. Commander Belknap's improvement consists, according to the *Engineering and Mining Journal*, of two cylinders, fixed one above the other when the instrument is set and descending through the water, and closing telescopically when the shot is detached on reaching the bottom. The lower cylinder is fitted with a conical cup at the lower extremity for the reception of parts of the bottom through an aperture, which, while descending, admits a flow of water upward through the cylinders by means of valves which close hermetically by the pressure of the water when the apparatus is being hauled up. The upper cylinder covers the aperture in the lower one on detaching the shot, so that the water

cannot wash out the bottom contained in the conical cup. Thus Commander Belknap has discovered a practical and unailing method of not only bringing up safely a larger amount of bottom from the ocean-bed than has hitherto been brought up, but also as much water as is caught between the two valves in the lower cylinder at the moment of striking the bottom.

## NOTES.

MORE than a thousand lives are lost each year in England from accidents in coal-mining.

ACCORDING to a writer in *Iron*, peals of bells were in use in England in the tenth century.

AN AGED GRAPE-VINE.—At the September meeting of the Royal Horticultural Society, a bunch of grapes was exhibited, taken from the parent plant of the Hampton Court vine. This vine dates from 1761.

F. V. KALLAB states, as the result of numerous experiments, that the dyes fixed on animal textile fabrics are in general more permanent than those on vegetable tissues.

A NEW currency is soon to be issued in the German Empire. Twelve different kinds of coins will represent all the variations of value, and four metals, gold, silver, nickel, and copper, will be used for the purpose. The system will be decimal throughout, but not uniform in values with any existing system.

NOBBE maintains that potash-salts in soils are necessary in order to enable the chlorophyl-grains of the leaves to form starch. Sodium and lithium are unable to replace potassium in this function, and the latter is even positively hurtful. The chloride of potassium is the most effective form in which this element can be supplied to the soil.

DR. ADAM SMITH, in a paper read before the London Society of Arts, recommends the use of tea in the following cases: After a full meal, when the system is oppressed; for the corpulent and the old; for hot climates, and especially for those who, living there, eat freely, or drink milk or alcohol; in cases of suspended animation; for soldiers who, in time of peace, take too much food in relation to the waste proceeding in the body; for soldiers and others marching in hot climates, for then, by promoting evaporation and cooling the body, it obviates, in a degree, the effects of too much food, as of too great heat.

A GENERAL meeting of Italian *savants* was to open at Rome on the 20th of October, to remain in session for two weeks. An invitation was extended to scientific men of foreign countries to attend the session. The committee of arrangements say that "this is the first time in many centuries that reason and science could freely and thoroughly make their voices heard in the city of Rome."

DR. C. PURDON, of Belfast, reports that lung-diseases are far more fatal to the flax-operatives of that town (in number 25,000) than to the artisans and laboring-classes. The most unwholesome branch of the flax industry is the work of the "preparing-room," which carries off annually 31 per thousand of the workers. Dr. Purdon asserts that this great mortality is chiefly due to these three causes: Putting children to work at too early an age; neglect of sanitary law; and defective food and clothing. He insists that the wearing of the Baker respirator should be made compulsory on the operatives.

IN the printing-office of the Cleveland *Ledger* a gas-pipe had been plugged with a hard-wood stopper, at a point several feet from any burner. About six inches below it passed a belt, running from one pulley to another, and in operation during the day. About four days after the plug had been driven into the pipe it was noticed to be on fire, and a bright jet of light, as if from a burner, burst forth from the side of the plug, which was already charred, and being rapidly burned up. The question now was, how the flame had originated. It was certain that no one had lighted it, nor had any fire come near it. The only conclusion possible was, that it was caused by electricity from the belt, and a full investigation confirmed this conclusion. Had it happened in the night-time, it might have enkindled an extensive conflagration, and its origin would never have been known.

ACCORDING to official reports, there were consumed in Paris, during the first half of 1867, 893 horses, asses, and mules, which supplied about 255,000 lbs. of meat. During the first half of 1870, 1,992 of these animals were slaughtered, giving about 980,000 lbs. of meat. For the first half of the present year the figures amounted respectively to 5,186 animals, and 2,368,000 pounds; and the same progress is shown by the provinces. Horses slaughtered for consumption fetch, on an average, from 125 to 150 francs per head—adding thus 100 francs per head to the value of worn-out horses. According to the reports, the public wealth of France is increased, by the eating of horse-beef, to the extent of 480,000,000 francs.

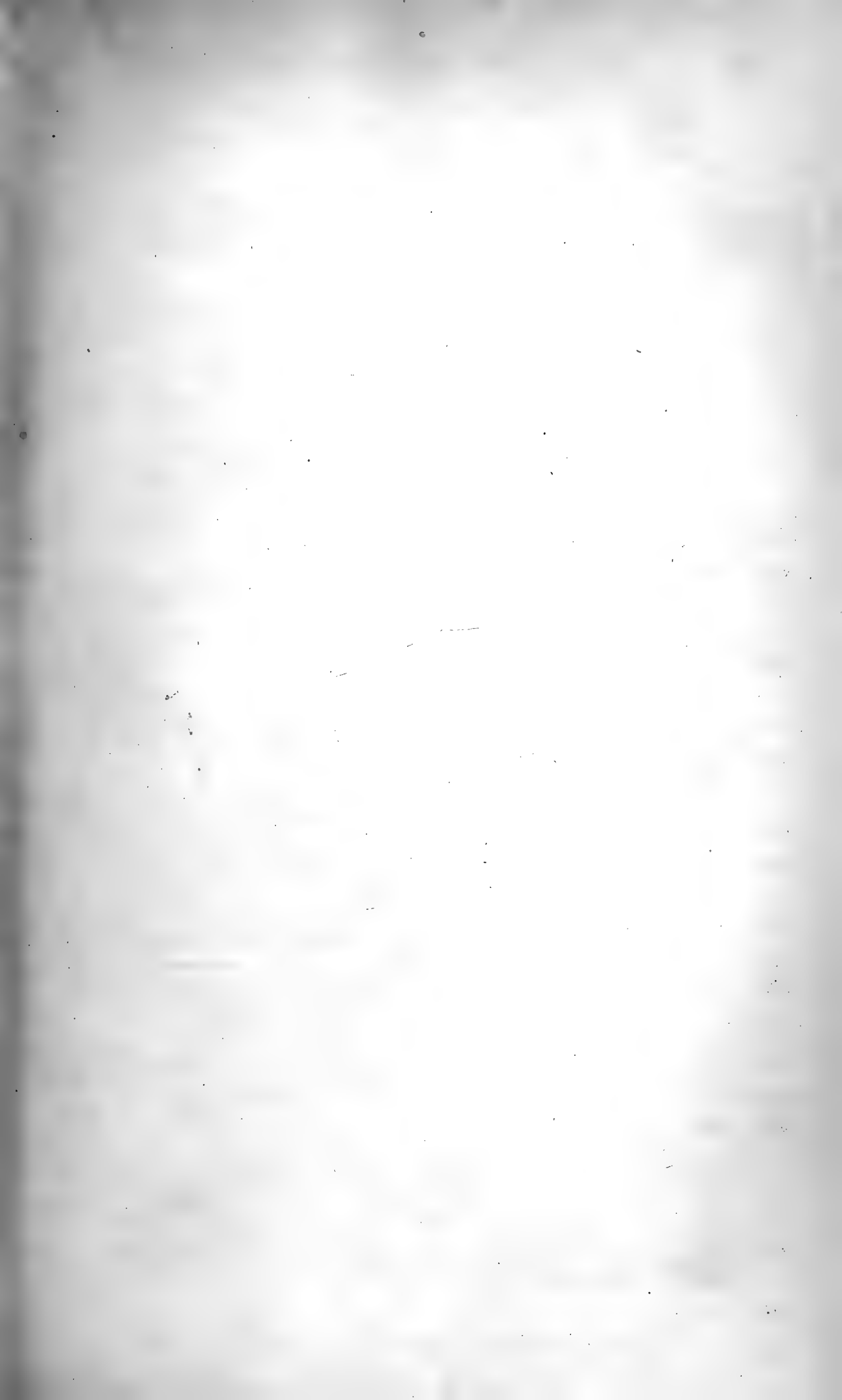



DR. J. W. DRAPER.

THE  
POPULAR SCIENCE  
MONTHLY.

---

JANUARY, 1874.

---

CONCERNING SERPENTS.

By ELIAS LEWIS, JR.

**F**EW animals are more universally feared and detested than serpents. Their presence startles us, however inoffensive they may be. Nor can the gracefulness of their motion, or beauty of color, conquer the discontent we feel when we see them gliding in our path, or coiled and glistening in the sunshine, in which they delight. The enjoyment of many a summer's ramble has been impaired from this cause, and we fear our article may be as distasteful to many persons as are the objects of which it treats. But we may remember that serpents, no less than more attractive creatures, are important in Nature's economies. Their structure is a marvel of mechanical adaptation, less complicated, perhaps, but as perfect in every detail as is that of mammals and birds, and the mechanism which rolls the human eye is not more complete, and scarcely more wonderful, than that which moves the fangs of a viper. Perhaps, in the study of Nature, we should estimate objects by their fitness, rather than by their attractiveness or beauty.

"The serpent," observes Prof. Owen, "is too commonly looked down upon as an animal degraded from a higher type. . . . But it can outclimb the monkey, outswim the fish, outleap the jerboa; it has neither hands nor talons, yet it can outwrestle the athlete, and crush the tiger in its embrace." Serpents, in their mode of locomotion, are creeping animals, as their name implies, and constitute an order of the great class Reptiles. This term also implies creeping, but includes orders of animals which have limbs for locomotion, and do not creep. Of these, turtles, lizards, and crocodiles, are familiar instances; so that animals of several species, which run, walk, or swim, are included in the same class with those which creep. All of these, however, are cold-blooded, the temperature of the body differing but few degrees from that of the surrounding air or water. Their coldness is always

obvious to the touch, and this is true with those found in hot as well as in temperate climates, and adds greatly to their repulsiveness.

FIG. 1.

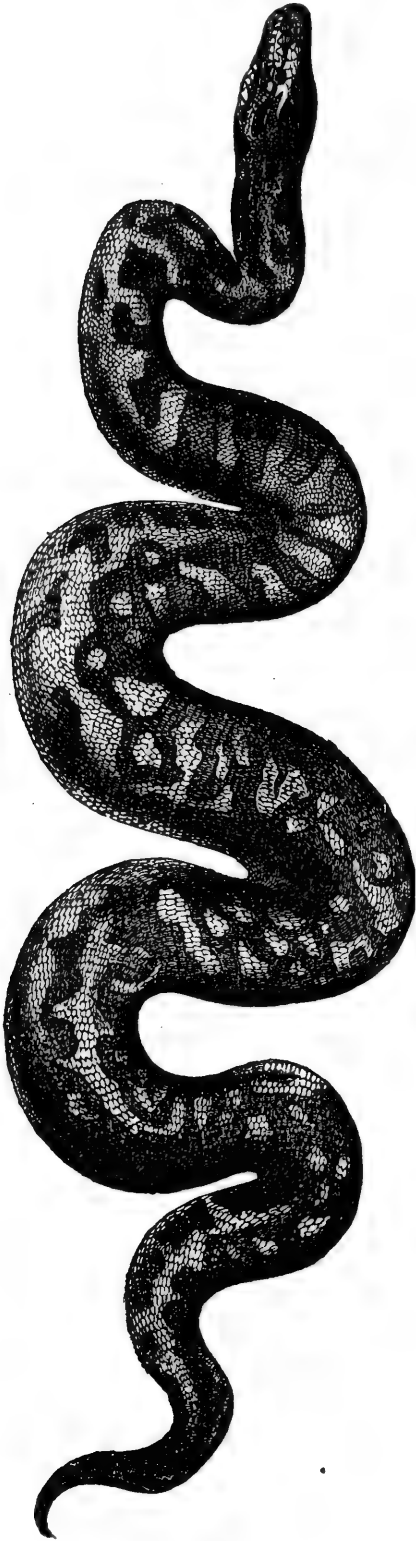

PORT NATAL ROCK-SNAKE, OR PYTHON.

Of serpents, their general form and structure are the same. Their bodies are rounded and elongated, and covered with a scaly skin. The vertebral column is continuous with the length of the body, and is divided into joints from 200 to 400 in number, but in the large pythons (Fig. 1), as stated by Dr. Carpenter, 422 vertebral joints have been counted. To about 360, or  $\frac{5}{7}$  of these, were attached pairs of movable ribs. A rattlesnake, with 194 vertebræ, had 168 pairs of ribs. The vertebræ of the serpent are united by a most perfect ball-and-socket joint, and the ribs are joined to the vertebræ in a similar manner. These, held and worked by complete muscular adjustment, give to several their wonderful flexibility, strength, and crushing power.

The well-known boa-constrictor, and the aboma, or ringed boa of South America (Fig. 2), are illustrations of this class of serpents, the term constrictor being given from their power to close upon and compress whatever is within their folds.

The structure of the backbone of a serpent has direct relation to its locomotion, for it is without limbs, and rudiments of pelvic bones are found only in the boas, pythons, and a few other species. But, where the type shades off into allied reptilian forms, the rudimental limbs are developed and prominent.

We read that the curse pronounced upon the serpent was, "upon thy belly thou shalt go," and the inference seems to be that, previous to that time, its mode of progression was not upon its belly. This would imply a great anatomical change in the structure of the creature at the time in question, a change which, so far as we are aware, is not proved by paleon-



tological research, and the expression is probably a figurative one, as observed by Dr. Buckland. Serpents progress by the "foldings and windings they make on the ground," and the stiff, movable scales which cross the under portion of the body; but the windings are sideways, not vertical.

FIG. 2.



ABOMA, OR RINGED BOA.

The structure of the vertebræ is such, that upward and downward undulations are greatly restricted, and many illustrations, showing sharp vertical curves of the body, are exaggerations. Most persons have seen snakes glide slowly and silently, without any contortion. They seem to progress by some invisible power; but, if permitted to move over the bare hand, an experiment easily tried, a motion of the scales will be perceived. These are elevated and depressed, and act as levers, by which the animal is carried forward. Nor can a serpent progress with facility on the ground, without the resistance afforded by the scales. It is stated that it cannot pass over a plate of glass, or other entirely smooth surface. We saw the experiment tried, by

placing a small pane of glass in a box, in which was a common black snake. He was made to pass over it repeatedly, but evidently found that he had no foothold on it; and the third time, as he approached it, elevated the fore-part of his body slightly, and brought his head down beyond the glass, and, on passing, his body seemed scarcely to touch it. This gave an opportunity to witness the wave-like movement of the scales, that is, of their elevation, which runs from the head to the tail, enabling the animal to move continuously, instead of by a series of minute pushes, as would occur if all the scales be lifted and depressed at once.

In the moulting of the snake, which occurs yearly, and sometimes oftener, the outer covering of these creeping scales is shed; this is true also of the covering of the eyes, so that the cast epidermis represents, with great distinctness, the external features of the animal. In moulting, the outer skin is broken along the back, near the head, and the animal emerges, frequently drawing with him the skin, turning it inside out. Prof. Owen states, however, that in one instance exuviation commenced by the snake rubbing the skin loose around its jaws, working it back against the sides of its cage, when, putting its head through coils made by its own body, it pressed back the skin, turning it outward. We have observed that the black snake, on moulting, becomes more sensitive and irritable, but shy, and inclined, for a day or so, to keep close in a corner of his cage. The scaly covering of serpents must diminish their acuteness of touch; but we have found them sensitive to exceedingly slight irritation. They are without an external ear, and the phrase "deaf as an adder" is a familiar one. Nevertheless, they have organs of audition beneath the skin or protecting membrane, and we know by experiment that snakes hear and distinguish sounds, and are said in some instances to recognize the voice of their keeper. Some species, it has been observed, are influenced by music, and we quote the statement by Chateaubriand of an incident witnessed by himself. He says: "The Canadian began to play upon his flute. The snake (a rattlesnake) drew its head backward, its eyes lost their sharpness, the vibrations of its tail relaxed, and, turning its head toward the musician, remained in an attitude of pleased attention."

The snake-charmers (Fig. 3), familiar to travelers in Eastern countries, handle cobras with apparent impunity, cause them to advance or retreat, to coil and uncoil, to bow their heads, or bring their deadly mouths to their own by musical sounds, either vocal or instrumental. A story is related of an English gentleman, residing in a mountainous part of India, who was compelled to desist playing upon a flute because the music attracted serpents to his residence. The sense of taste in serpents must be very feeble, as it is quite unserviceable. They swallow their food whole, nor have they any teeth by which mastication can be accomplished. Their sense of smell is also obtuse. The

FIG. 3.

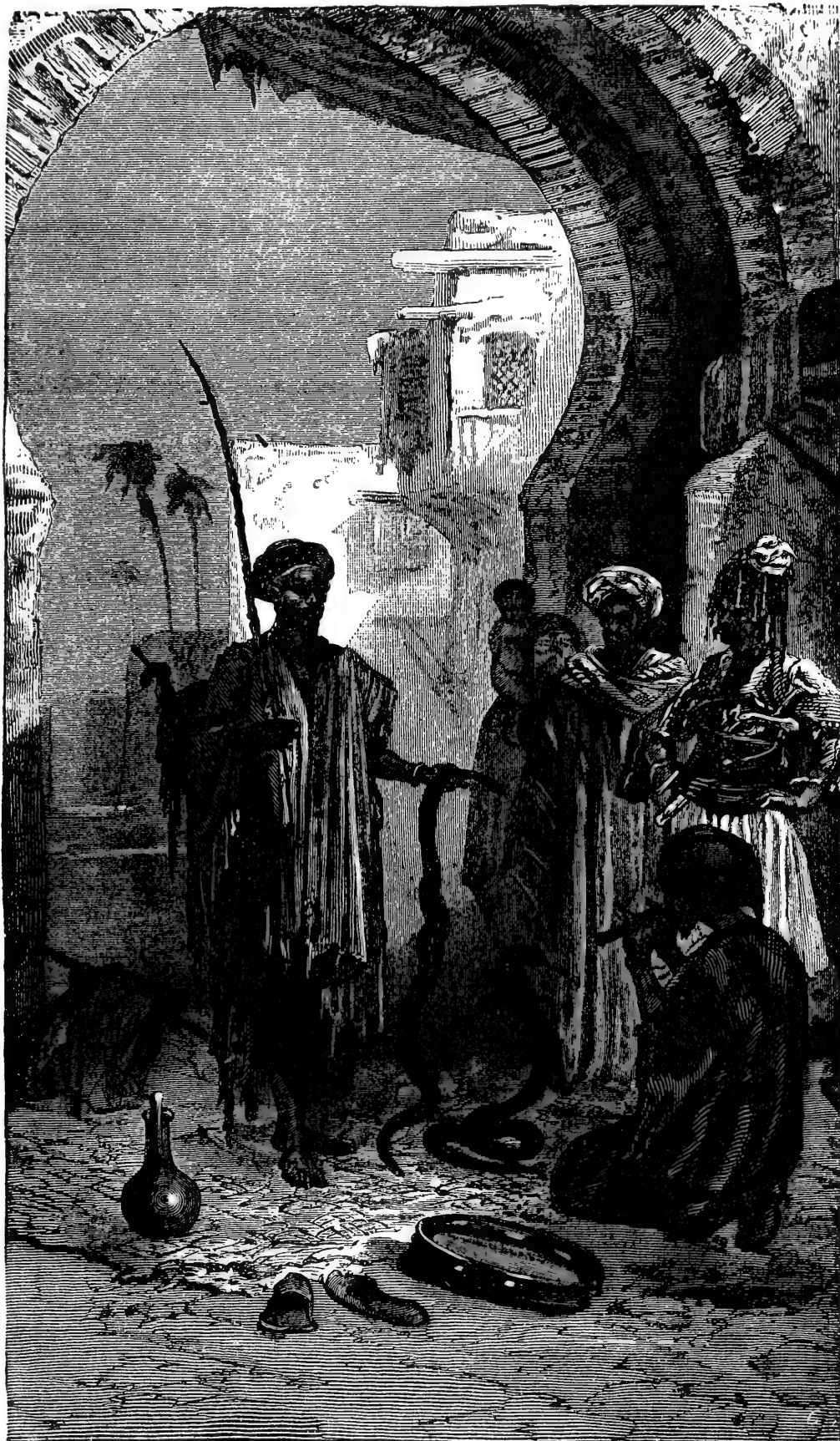

SNAKE-CHARMERS.

organs by which this is effected are near the muzzle, but, according to Cuvier, they are without the sinuses which exist in the heads of mammals. We have tested this sense in several species of snakes, but only pungent odors seem to specially annoy them. The tongue of the serpent is a harmless appendage, tough, horny, and double-pointed; and, like the same member in man, has a wonderful propensity to be in motion. That snakes sting with their tongues is an old but erroneous opinion. Perhaps our own species is not equally innocent in that respect. All serpents are carnivorous, and nearly all seize and swallow living food. Their teeth are bony, hard, conical in shape, and exceedingly sharp-pointed. None of the class have grinding or cutting teeth. They are formed for holding their food, not to grind, crush, or cut it. Moreover, all their teeth are recurved in form and position; that is, they point in or backward, so that an object once seized can scarcely escape, and, if the jaws be fully distended, could only with great difficulty be ejected. Instances are given where serpents have died from their inability to swallow what they could not eject from their throats, and it is obvious that life could not continue a very long time under such circumstances, for, as Prof. Owen observes, "while swallowing, the tracheæ may be so compressed that no air can pass, and their only resource is what is contained in the lungs."

In the non-venomous species, which includes those that constrict or crush their prey, are found four rows of teeth in the upper jaw and arch of the mouth, and two rows in the under jaw. Venomous species have usually no more than two rows above, which are on the palatal arch, and two below; but they have on the upper jaw two or more poison-fangs, as shown in Fig. 4, an account of which makes the most fearful chapters in the history of this family of reptiles.

FIG. 4.

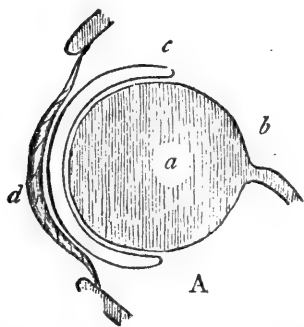

A. DIAGRAMMATIC SECTION OF THE EYE OF A VIPER.

a. Eyeball; b. Optic nerve; c. Chamber into which tears are poured; d. Epidermic layer covering the eye.

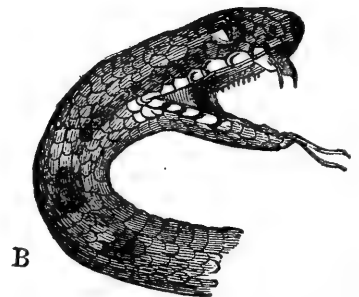

B. HEAD OF VIPER, SHOWING POISON-FANGS.

We have observed that serpents swallow their food whole. They make a meal from a mouthful, but the mouthful is sometimes a very large one, for they will swallow animals twice or thrice their own

diameter. This is permitted by the extraordinary expansibility of their body; but the enlargement of their jaws is a complicated phenomenon. In the act of swallowing, they yield at every point, sideways as well as vertically. The elastic integuments which hold the parts of their jaws in place give way, and the apparently small mouth becomes an enormous one.

Digestion proceeds slowly, and, if the meal be excessive, as it often is, the serpent remains sluggish and comparatively helpless a long time. "They have been kept four, six, and eight months, without being fed, and with very little apparent waste of substance." Bruce reports that he kept specimens of the cerastes, or horned-snake, two years in a glass vessel without food, during which time they cast their skins as usual.

FIG. 5.

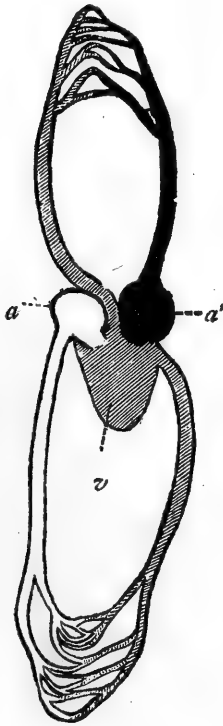

CIRCULATING SYSTEM OF REPTILE.

*a.* Auricle receiving worn-out venous blood from the system; *a'*. Auricle receiving vitalized blood from the lung; *v.* Ventricle in which the two bloods are mixed, and from which it is thrown into the general circulation.

Vital activity in serpents is low. In mammals, the normal mean temperature is from  $95^{\circ}$  to  $105^{\circ}$  Fahr., and this must be maintained, or disease supervenes. With serpents, the temperature is a few degrees only above that of the surrounding atmosphere, and varies with it. Thus, it may range, in their healthy active state, from  $60^{\circ}$  to perhaps more than  $80^{\circ}$  Fahr. The temperature of a serpent was found, by Hunter and others, to be  $88.46^{\circ}$ , that of the air being  $81.5^{\circ}$ . The temperature of a frog was  $48^{\circ}$  in water at  $44.4^{\circ}$ . If the atmosphere be

continuously at  $60^{\circ}$ , some of our common snakes become sluggish and inactive. In both mammals and reptiles the source of internal heat is the same, the difference being in degree only. The low temperature of serpents (as of other reptiles) arises from the structure of their vital organs, by means of which their blood is imperfectly oxygenized. As the "worn-out" or venous blood enters the heart, it is *mixed* with the vitalized blood from the lung (there being, in most species, only one lung and a rudiment of another), and it is this mixed blood which is thrown into the general circulation, as shown in Fig. 5. The blood of a serpent has been said for this reason to be

FIG. 6.



ANACONDA.

only half alive, and their functions are accordingly sluggish and dull. Their power of existence for long periods without food, and with little waste of tissue, is chiefly incident to their low vitality.

Hibernation is with them a period of profound torpor. In our temperate climates they gather in large numbers, in some hole, or bur-



row in the ground, or in clefts of rocks, for their winter sleep. We once saw twenty-six black snakes taken from one burrow beneath the roots of a partially-fallen tree, in February. Other observers have found a much larger number. We are informed that more than 300 have been found in a single burrowing-place, and that many species, venomous and non-venomous, sometimes resort to the same rendezvous and hibernate together. In the tropics the anaconda (Fig. 6), and perhaps other species of serpents, sometimes hibernate during the dry season of summer in the hardened mud of dried-up pools. It is by the power to hibernate that serpents survive during the winters of temperate climates, but they seem unable to withstand the extreme and long-continued cold of the arctic zone. There, serpents, and in-

FIG. 7.

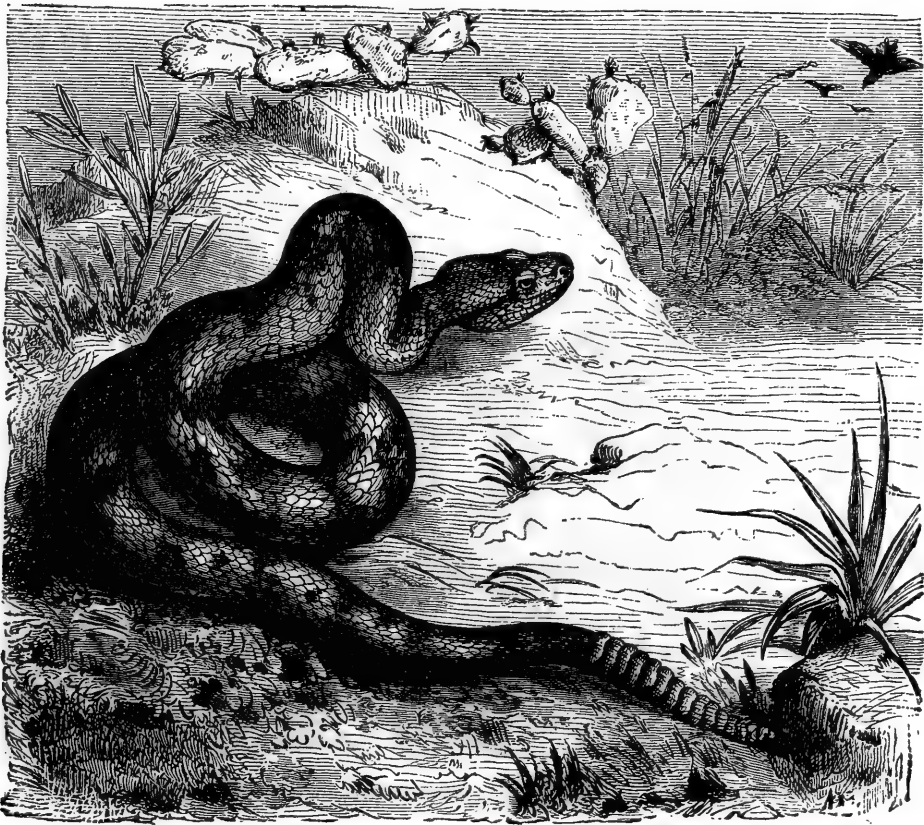

NORTHERN RATTLESNAKE.

deed reptiles of all kinds, are rare, and frequently are entirely wanting. In the Falkland Islands, Terra del Fuego, and the mountains of Southern Patagonia, no serpents have been found. The persistence of vitality in serpents is extraordinary, and continues after great mutilations. They are said to have lived several days after removal of the head and viscera. One placed in a vacuum twenty-four hours still showed signs of sensibility; and, many hours after decapitation, a rattlesnake would plunge its headless trunk as in the usual act of striking.

In temperate climates serpents as a rule are less fierce than in the tropics. In North America the *Crotalidæ* comprise twelve species with rattles, and three species in which rattles are absent. Of the last named, the copperhead and moccasin snakes are well known. Of the first, the northern rattlesnake (Fig. 7) is familiar, and unpleasantly abundant in many parts of the country, but is nowhere fierce or inclined to attack. Fig. 8 is of the common viper, or adder of England and the Continent.

All the gigantic crushing species are found in regions of torrid temperature. Of these, the Guinea rock or fetich snake (Fig. 10) is allied to the family of pythons already noticed.

There too are the most terribly fierce of the venomous species, as the fer de lance (Fig. 11); the cobra (Fig. 12), sacred in India, the killing of which with some tribes is considered sacrilege; the haje or spitting-snake of Africa, a hooded species, and allied to the cobra, and the horned puff-adder (Fig. 13), whose poison is used to tip arrows by the South-African Bushmen.

FIG. 8.

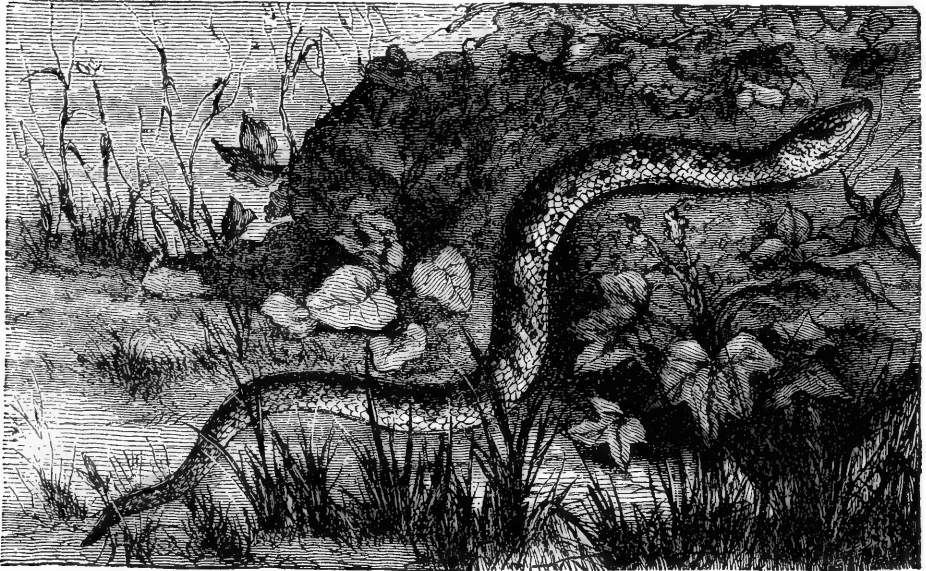

COMMON ADDER OF ENGLAND AND THE CONTINENT.—(VENOMOUS.)

The mere recital of their names excites in one unpleasant sensations. Deaths from the bite of serpents in temperate regions which they infest are surprisingly rare. It is otherwise, however, in the tropics, and perhaps no country has so fearful a mortality from the bites of venomous snakes as India. In six provinces, which include Assam and Orissa, with a population of about 121,000,000, 11,416 deaths were reported in a single year. This is about one in every 10,000 of population, and this is only an approximation to the actual mortality, for many districts sent no returns. A majority of all the deaths from this cause was from cobras; yet this serpent, as ob-

served, is an object of veneration, and is regarded with peculiar deference. If found in their houses, as it frequently is, it must be petted, cared for, tenderly fed, and propitiated, for it is an object of worship, and occupies a high place in the mythology of the Hindoos. Indeed, the worship of serpents seems to have been widely adopted, and figures more or less in a vast number of the religions of the world. It is often referred to in the Scriptures, and is a subject of elaborate discussion in the profoundly learned and interesting volume of Ferguson, on "Tree and Serpent Worship."

We mentioned the fact that in most species serpents have but one fully-developed lung. Into the cavity of this the trachea or windpipe terminates, and it has been stated that they "in a manner swallow air." What takes place in the process of breathing appears to be this. Unlike mammals, serpents have no diaphragm, but by a movement of the ribs the cavity of the body is enlarged, and, a pressure being thus removed, the lung inflates and expands by the air passing into it. Another and opposite movement of the ribs expels the air, whence it appears that their process of breathing is essentially the same as in mammals. Nor are their lungs in structure essentially different. The air sacs or cells communicate with the principal pulmonary tube, but a vastly smaller surface is exposed to the inhaled air, and aëration of the blood is consequently extremely imperfect and incomplete.

FIG. 9.

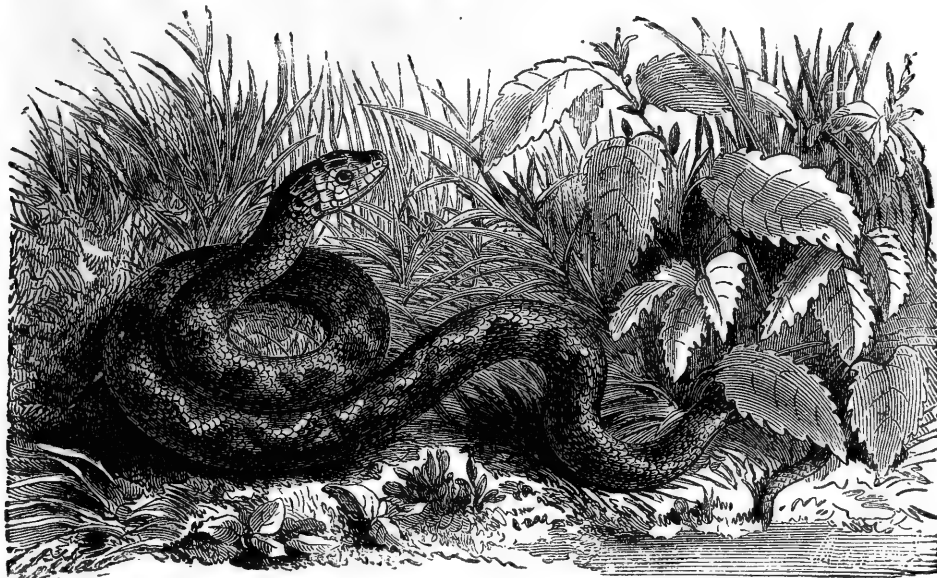
SMALL VIPERINE SNAKE (*Tropidonotus Viperinus*).

Serpents are without proper organs of voice, the vibrating membranes being absent. The passage of air into and out of the lungs, if hurried and rapid, produces a hissing noise, the only voice possible to them, but which we fear makes less interesting their somewhat unprepossessing features.

A scale-like covering, which is fixed and immovable, covers the eye of the serpent, as shown in Fig. 4, and gives to it, as Prof. Nicholson vividly expresses it, the "peculiar, stony, unwinking stare" for which they are remarkable, and which, when they are enraged, becomes intensely fierce.

FIG. 10.



GUINEA ROCK-SNAKE.

This covering is evidently transparent, as the animal distinguishes forms, but in the cast-off skin it is translucent only. Behind the eye-ball is a lachrymal gland, with a duct which conveys tears to the membranes of the eye. By this means they are kept moist. A conduit connects the eye-cavity with the olfactory opening, and, should the creature shed tears, it would be through that opening, not directly from its eyes.

In common with other animals, serpents have some habits and



instincts peculiar to themselves, which are directly related to the necessities of their being; but we are not aware that they display great sagacity, cunning, or wisdom. They are not fertile in devices, not especially artful, and the extreme simplicity and smallness of their brain indicate their low mental powers.

The entire tribe of serpents for the purposes of this paper may be divided into the venomous and non-venomous species. Of the non-venomous, we will pass, with one or two remarks, the interesting families of double walkers, and slow or blind worms (Fig. 14), types which are structurally intermediate between true serpents and lizards. The first of these derives its name from the fact that it can progress

FIG. 11.

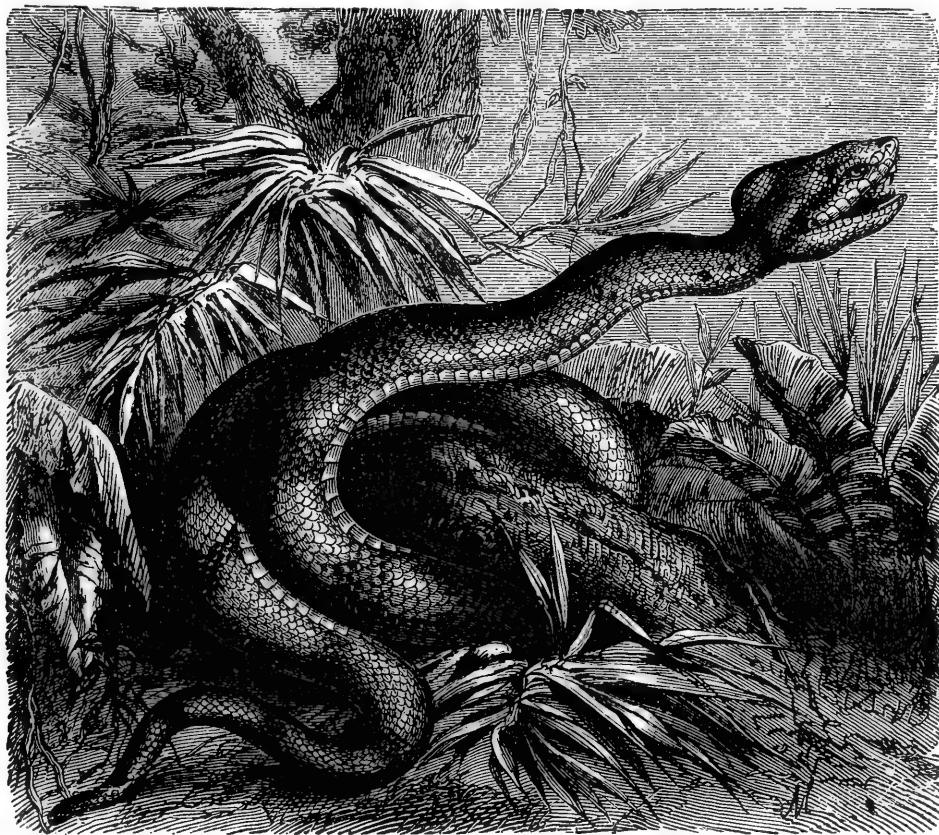

FER DE LANCE.

with facility forward or backward; the second from the erroneous notion that it has no eyes. To this class belong the curious glass-snakes, so named from their fragility. Other non-venomous serpents comprise the inoffensive and harmless, and some of the most terrible species. Of these we have noticed the gigantic rock-snake or python of India, which attains a length of 30 feet. The Natal rock-snake is found 25 feet long. Of equal size is the boa-constrictor of tropical America, formerly an object of worship. The anaconda, or water-serpent, which frequents the rivers of Brazil, and watches for its prey along their banks, is sometimes more than 25 feet long. These are

among the most powerful of their kind, in whose folds man is helpless, and bones of goats and cattle are broken with a crash which, it is said, may be heard many rods. We turn from these, whose fearful presence we associate with the splendors of tropical forests, to species harmless and often serviceable to man, yet everywhere persecuted by him. Among these we find the beautiful ring and grass snakes of our gardens; the milk and striped or garter snake; the common adder (so called), but entirely harmless; the active black snake or racer, found nearly everywhere in the United States. More dreaded because more dangerous than the gigantic species mentioned, are the venom-

FIG. 12.

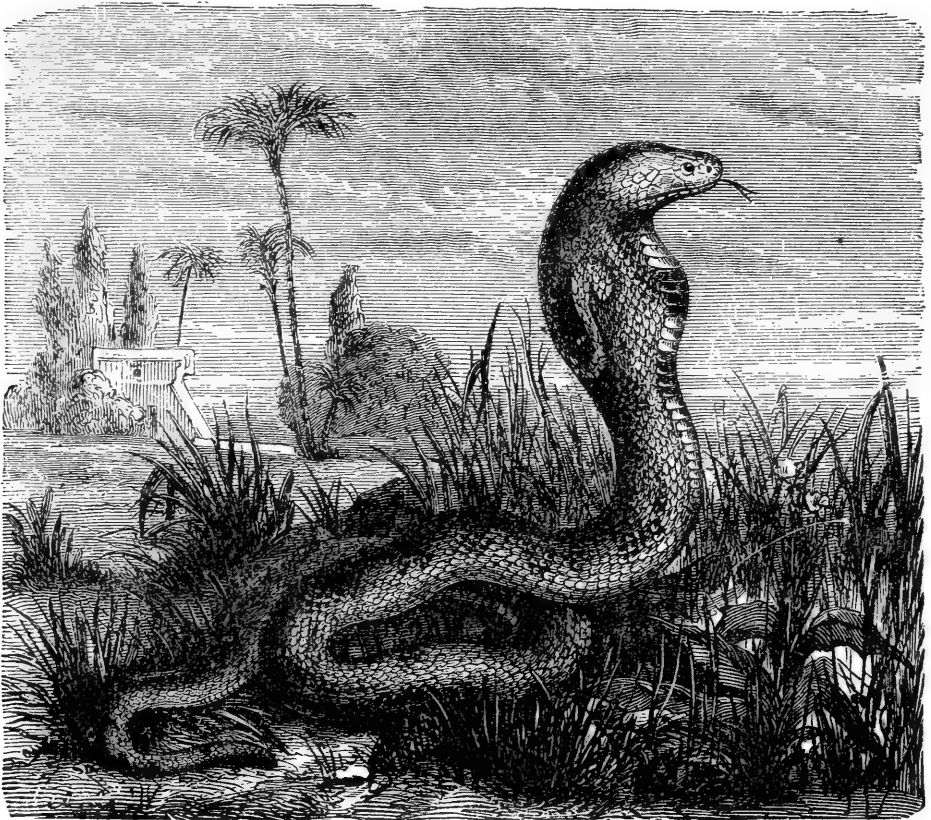

COBRA-DE-CAPELLO.

ous serpents, not powerful in strength or immense in size, but fierce in some cases, and in their attack deadly. The largest of these is said to be the bush-master, found in British Guiana, which, on the authority of Waterton, attains a length of fourteen feet. But the belted hamadryad of Burmah is often seen twelve to fourteen feet in length, and is a foot in circumference; and it is stated that specimens have been seen three fathoms (eighteen feet) long. If so, it is probably the largest known venomous serpent. This terrible creature feeds on other snakes, hence its scientific name, *Ophiophagus elaps*. Others, as the cobra and the rattlesnake, are relatively small, rarely attaining a length greater than six feet, usually not more than four feet.



But the distinguishing feature of venomous serpents is their poison fangs and glands, by which the fatal fluid is secreted. They kill by a stroke, or blow, which drives the fang into the flesh, and there discharges the venom. Some are intensely active and fierce, and will spring upon the traveler, as the fer de lance and the haje. Others, as the northern rattlesnake, seldom attack but rather retreat from man.

The fangs are in the upper jaw, as shown in Fig. 4. In a rattlesnake, four feet in length, they are about half an inch long. Behind them are the glands, which secrete the poisonous fluid, from five to ten drops of which have, in some cases, been obtained from a single fang. It is tasteless, and nearly colorless, and, on being dried up, leaves minute crystalline spicules, or scales. The venom of all the poisonous species of serpents appears to be essentially the same, but differs in intensity or virulence. The fang is perforated by a small canal in

FIG. 13.

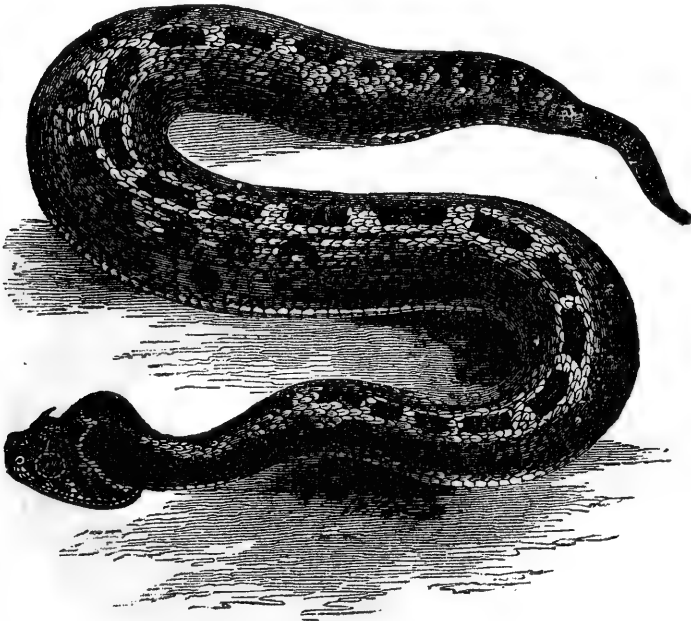

THE HORNED PUFF-ADDER.

front of the usual pulp-cavity, through which the venom is discharged by pressure brought to bear upon the glands from the act of striking. A rattlesnake confined in a cage, when irritated, struck against the wire bars with its fangs, throwing the venom a distance of three feet. The fang usually lies flat, and partly hidden in the fleshy tissue, but is erected when needed for use; and it is only when erected that its connection with the venom-gland is so adjusted that the fluid may be thrown out.

The poison is always more or less dangerous to animal life. Cattle have died from a bite of the fer de lance in a few hours. Smaller animals die directly. Horses have been killed by rattlesnakes, and people bitten by them may die in a few minutes or in a few days, but

sometimes recover. If the poison is discharged into the arteries or veins, the vital functions directly fail, "the victim staggers, and falls from exhaustion—depressing gloom settles on the features—a cold sweat comes upon the face—and death at once supervenes." In such cases the blood is unchanged, and appears healthy; but, where the effect is not immediate, it undergoes change—"ceases to coagulate, the fibrine disappears, and the patient dies with ordinary symptoms of slow poisoning."

A multitude of remedies have been suggested for the bite of serpents; of these, ammonia and alcohol are prominent. Prof. Halford, of Australia, reported the recovery of seventeen out of twenty cases of severe bites, from the injection of a solution of ammonia into the veins. The free use of alcohol in some form has been stoutly advocated by many physicians, while others assert that patients have died from the poison even while intoxicated by the remedy. An exhaustive paper

FIG. 14.

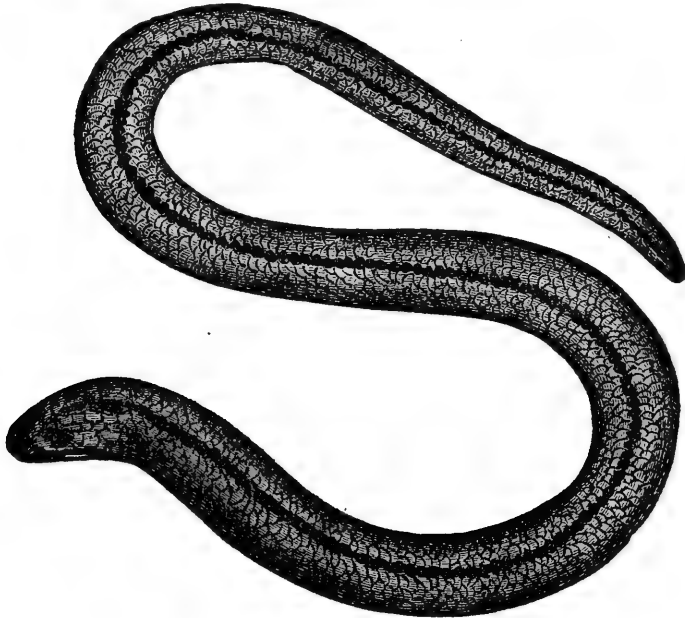

BLIND OR SLOW WORM.

on rattlesnake-bites, and their remedy, by Dr. Mitchell, was published in No. 12 of the "Smithsonian Contributions to Knowledge," to which we are indebted for several interesting statements, and to which we refer our readers.

The conclusions of Dr. Fayrer, from his exhaustive experiments upon snake-poisoning in India, are, that most of the popular remedies are of little value, and he seems to differ somewhat from Prof. Halford. The celebrated snake-stones, which are said to "absorb and suck out the poison," he "believes are perfectly powerless to produce any such effect." He advises ligature to prevent, if possible, the passage of the poison into the circulation. Whiskey and ammonia are

useful as stimulants; but he found, by experiment, that neither liquor ammoniæ nor liquor potassæ destroys the poisonous properties of the venom, although mixed directly with it. Suction of the wound is good, but may be dangerous. Immediate cauterization of the wound, or removal of it by the knife, is indispensable.

It was found, by Dr. Gilman, that healthy, vigorous vegetables perish in a few hours on being inoculated with the venom of the rattlesnake. Others have found the same results, although Dr. Mitchell did not. Dr. Salisbury poisoned eight lilac and other bushes, the leaves of which above—not below—the point of inoculation withered in a few days. Terrible and virulent as this poison is, it undergoes decomposition in a short time, and becomes filled with forms of animal life and covered with fungi. It may, when fresh from the fang, be swallowed by the animal itself, or by man, without injury. Prof. Baird says: "I have myself (rather foolishly, I must confess) swallowed nearly the entire contents of one gland of a large rattlesnake;" but, if the animal be inoculated by its own venom, it speedily dies. Such, however, is not the case with the venom of the cobra, according to experiments made by Dr. Fayrer, who says: "I believe that it is

FIG. 15.

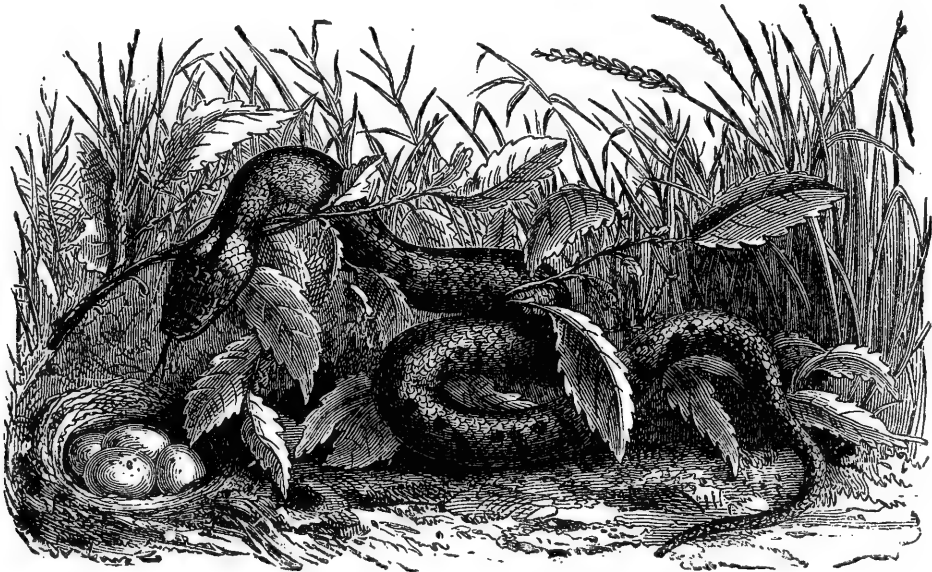

RING OR GRASS SNAKE, COMMON IN ENGLAND.

capable of absorption, through the mucous and serous membranes with which it is brought into contact. Placed on the conjunctiva of dogs, the symptoms of poisoning were rapidly developed." The same authority states that the cobra does not die from its own bite, or that of its kind, but that innocuous serpents are directly killed by it.

It is a singular fact that the *flesh* of animals killed by snake-poison may be eaten with impunity. The fowls killed by Dr. Fayrer were taken and eaten by the sweepers. But the blood of an animal killed by snake-venom is itself poisonous, and poisons the animal into which

it is injected. The authority just quoted says: "I have transmitted the poison through three animals, with fatal results."

The formation of rattles upon the tail of a rattlesnake is a curious phenomenon. The notion that one is developed each year is incorrect. Young ones have been known to have six or more; sometimes two or three appear in a single year. The number seldom exceeds fifteen. The skin of one that was six feet long, now in the Museum of the Long Island Historical Society of Brooklyn, has fourteen rattles. De Kay cited, in 1842, the *Clarion* newspaper, published at Bolton, New York, which stated that two men killed, in three days, in the town of Bolton, at Lake George, 1,104 rattlesnakes, some of which carried fifteen to twenty rattles. They were killed for their oil. The same author states, on the authority of the *Columbian Magazine* for November, 1786, that a rattlesnake was killed, having forty-four rattles, which seems an incredible number. The use of the rattles is a subject of discussion. They are evidently well developed—not rudimental merely—and the conclusion is irresistible that they are of service to the creature. We cannot suppose that organs which are constant in a class of animals, could have originated, if entirely useless and unserviceable to it. Prof. Aughey suggests that the whirring rattle is a call-note by the animal to its mate. That it was thus used on one occasion he was an eye-witness. Again, it may be used to terrify its enemies; or to paralyze its victims with fright, or to call assistance in danger. He says: "I once witnessed an attack by seven hogs on a rattlesnake. Immediately the snake rattled, and three others appeared; but the hogs were victorious."

The power of serpents to overcome birds by fascination is considered by most writers doubtful. But it cannot be questioned, we think, that birds sometimes become powerless in the presence of snakes. We once saw a cat-bird on a low branch with drooped wings, feathers erect, and mouth open, apparently breathing heavily, looking directly at the head of a black snake which was within fifteen inches of the head of the bird, and very slowly moving forward. A sharp blow on a board startled the snake, and seemed instantly to release the bird from its dream, when it flew away. Perhaps the able paper on "Hypnotism in Animals," by Prof. Czermak, published in *THE POPULAR SCIENCE MONTHLY* for September, 1873, may suggest a possible solution of this phenomenon.

All serpents are essentially oviparous; that is, the young are produced from eggs. Nevertheless, many species, including all the venomous ones, according to Cuvier, bring forth their young alive; but this is in consequence of the eggs being hatched before being laid. A boa-constrictor produced *both* eggs and living young in the Zoological Gardens at Amsterdam. The eggs of serpents are without a calcareous shell, and those of our common species are often exposed in turning the ground in fields and in gardens. The young are at once quite ac-

tive, and we have seen them when very young display the instinctive habits of their species.

The python coils around her eggs, and faithfully remains there during their two months of incubation; the temperature of her body rising, in one instance, to 96° Fahr. All this time she refuses food, "but appears feverish, and drinks water freely."

The time when serpents first appeared upon the globe is comparatively recent. No fossil remains of them have yet been discovered, until after the close of the Age of Reptiles. The oldest yet found were in the Eocene of the south of England. Prof. E. D. Cope first found them in the United States in the Eocene of New Jersey. They have been found also by Prof. Marsh in the Eocene of Wyoming. Prof. Cope discovered five new species during the past summer in the Miocene of Colorado, and has also obtained them from Post-Pliocene formations. So it appears that, during the whole of the Tertiary, serpents abounded, and the fact that in the Eocene they were so widely distributed suggests a much earlier origin for this order of reptiles. How numerous they may have been during periods subsequent to their advent is not easily determined. But, notwithstanding their abundance in the tropics, and in contiguous regions, it is probable that their period of greatest abundance, if not of greatest development, has passed. Civilization destroys them, or drives them to the swamps, the mountains, and the wilderness.

The number of species of snakes found in the State of New York is seventeen. Two of these are venomous, the rattlesnake and the viper. Sixteen species are named in Prof. Cook's catalogue for New Jersey, and that gentleman remarks: "All of them are of great value to the agriculturist, and the popular prejudice against them should be done away with." It should be more widely known and more often considered that snakes destroy immense numbers of animals which are detrimental to the interests of man, as rats, mice, insects, larvæ, and worms of various kinds. The fer de lance infests the sugar-plantations of some of the West India islands, not to destroy men, who fear it, but to obtain rats for food, which swarm there in incredible numbers. In the State of Maine are ten species of snakes, in Michigan fifteen species, and from Baird and Girard's catalogue, published in 1853, we learn that 119 species of North American serpents were at that time known and described.

In the older settled portions of the United States their numbers have diminished, and in the more thoroughly cultivated sections of New England, New York, New Jersey, and perhaps other States, their scarcity is a matter of common observation. Before persistent warfare, and amid conditions which are becoming more unfavorable to their habits of life, they will doubtless become fewer in number and species, and, in such regions, the period of their extinction may not be very remote.

THE THEORY OF MOLECULES.<sup>1</sup>

BY PROFESSOR CLERK MAXWELL, F. R. S.

**A**N atom is a body which cannot be cut in two. A molecule is the smallest possible portion of a particular substance. No one has ever seen or handled a single molecule. Molecular science, therefore, is one of those branches of study which deal with things invisible and imperceptible by our senses, and which cannot be subjected to direct experiment.

The mind of man has perplexed itself with many hard questions. Is space infinite, and if so in what sense? Is the material world infinite in extent, and are all places within that extent equally full of matter? Do atoms exist, or is matter infinitely divisible?

The discussion of questions of this kind has been going on ever since men began to reason, and to each of us, as soon as we obtain the use of our faculties, the same old questions arise as fresh as ever. They form as essential a part of the science of the nineteenth century of our era, as of that of the fifth century before it.

We do not know much about the science organization of Thrace twenty-two centuries ago, or of the machinery then employed for diffusing an interest in physical research. There were men, however, in those days, who devoted their lives to the pursuit of knowledge with an ardor worthy of the most distinguished members of the British Association; and the lectures in which Democritus explained the atomic theory to his fellow-citizens of Abdera realized, not in golden opinions only, but in golden talents, a sum hardly equaled even in America.

To another very eminent philosopher, Anaxagoras, best known to the world as the teacher of Socrates, we are indebted for the most important service to the atomic theory, which, after its statement by Democritus, remained to be done. Anaxagoras, in fact, stated a theory which so exactly contradicts the atomic theory of Democritus that the truth or falsehood of the one theory implies the falsehood or truth of the other. The question of the existence or non-existence of atoms cannot be presented to us this evening with greater clearness than in the alternative theories of these two philosophers.

Take any portion of matter, say a drop of water, and observe its properties. Like every other portion of matter we have ever seen, it is divisible. Divide it in two, each portion appears to retain all the properties of the original drop, and among others that of being divisible. The parts are similar to the whole in every respect except in absolute size.

<sup>1</sup> Lecture delivered before the British Association at Bradford.



Now go on repeating the process of division till the separate portions of water are so small that we can no longer perceive or handle them. Still we have no doubt that the subdivision might be carried further, if our senses were more acute and our instruments more delicate. Thus far all are agreed, but now the question arises, Can this subdivision be repeated forever?

According to Democritus and the atomic school, we must answer in the negative. After a certain number of subdivisions, the drop would be divided into a number of parts each of which is incapable of further subdivision. We should thus, in imagination, arrive at the atom, which, as its name literally signifies, cannot be cut in two. This is the atomic doctrine of Democritus, Epicurus, and Lucretius, and, I may add, of your lecturer.

According to Anaxagoras, on the other hand, the parts into which the drop is divided are in all respects similar to the whole drop, the mere size of a body counting for nothing as regards the nature of its substance. Hence if the whole drop is divisible, so are its parts down to the minutest subdivisions, and that without end.

The essence of the doctrine of Anaxagoras is, that the parts of a body are in all respects similar to the whole. It was therefore called the doctrine of Homoiomereia. Anaxagoras did not of course assert this of the parts of organized bodies such as men and animals, but he maintained that those inorganic substances which appear to us homogeneous are really so, and that the universal experience of mankind testifies that every material body, without exception, is divisible.

The doctrine of atoms and that of homogeneity are thus in direct contradiction.

But we must now go on to molecules. Molecule is a modern word. It does not occur in Johnson's "Dictionary." The ideas it embodies are those belonging to modern chemistry.

A drop of water, to return to our former example, may be divided into a certain number, and no more, of portions similar to each other. Each of these the modern chemist calls a molecule of water. But it is by no means an atom, for it contains two different substances, oxygen and hydrogen, and by a certain process the molecule may be actually divided into two parts, one consisting of oxygen and the other of hydrogen. According to the received doctrine, in each molecule of water there are two molecules of hydrogen and one of oxygen. Whether these are or are not ultimate atoms I shall not attempt to decide.

We now see what a molecule is, as distinguished from an atom.

A molecule of a substance is a small body such that if, on the one hand, a number of similar molecules were assembled together they would form a mass of that substance, while on the other hand, if any portion of this molecule were removed, it would no longer be able, along with an assemblage of other molecules similarly treated, to make up a mass of the original substance.

Every substance, simple or compound, has its own molecule. If this molecule be divided, its parts are molecules of a different substance or substances from that of which the whole is a molecule. An atom, if there is such a thing, must be a molecule of an elementary substance. Since, therefore, every molecule is not an atom, but every atom is a molecule, I shall use the word molecule as the more general term.

I have no intention of taking up your time by expounding the doctrines of modern chemistry with respect to the molecules of different substances. It is not the special but the universal interest of molecular science which encourages me to address you. It is not because we happen to be chemists or physicists or specialists of any kind that we are attracted toward this centre of all material existence, but because we all belong to a race endowed with faculties which urge us on to search deep and ever deeper into the nature of things.

We find that now, as in the days of the earliest physical speculations, all physical researches appear to converge toward the same point, and every inquirer, as he looks forward into the dim region toward which the path of discovery is leading him, sees, each according to his sight, the vision of the same quest.

One may see the atom as a material point, invested and surrounded by potential forces. Another sees no garment of force, but only the bare and utter hardness of mere impenetrability.

But though many a speculator, as he has seen the vision recede before him into the innermost sanctuary of the inconceivably little, has had to confess that the quest was not for him, and though philosophers in every age have been exhorting each other to direct their minds to some more useful and attainable aim, each generation, from the earliest dawn of science to the present time, has contributed a due proportion of its ablest intellects to the quest of the ultimate atom.

Our business this evening is to describe some researches in molecular science, and in particular to place before you any definite information which has been obtained respecting the molecules themselves. The old atomic theory, as described by Lucretius and revived in modern times, asserts that the molecules of all bodies are in motion, even when the body itself appears to be at rest. These motions of molecules are, in the case of solid bodies, confined within so narrow a range that even with our best microscopes we cannot detect that they alter their places at all. In liquids and gases, however, the molecules are not confined within any definite limits, but work their way through the whole mass, even when that mass is not disturbed by any visible motion.

This process of diffusion, as it is called, which goes on in gases and liquids and even in some solids, can be subjected to experiment, and forms one of the most convincing proofs of the motion of molecules.

Now, the recent progress of molecular science began with the study of the mechanical effect of the impact of these moving molecules when they strike against any solid body. Of course these flying molecules must beat against whatever is placed among them, and the constant succession of these strokes is, according to our theory, the sole cause of what is called the pressure of air and other gases.

This appears to have been first suspected by Daniel Bernoulli, but he had not the means which we now have of verifying the theory. The same theory was afterward brought forward independently by Lesage, of Geneva, who, however, devoted most of his labor to the explanation of gravitation by the impact of atoms. Then Herapath, in his "Mathematical Physics," published in 1847, made a much more extensive application of the theory to gases; and Dr. Joule, whose absence from our meeting we must all regret, calculated the actual velocity of the molecules of hydrogen.

The further development of the theory is generally supposed to have been begun with a paper by Krönig, which does not, however, so far as I can see, contain any improvement on what had gone before. It seems, however, to have drawn the attention of Prof. Clausius to the subject, and to him we owe a very large part of what has been since accomplished.

We all know that air or any other gas placed in a vessel presses against the sides of the vessel, and against the surface of any body placed within it. On the kinetic theory this pressure is entirely due to the molecules striking against these surfaces, and thereby communicating to them a series of impulses which follow each other in such rapid succession that they produce an effect which cannot be distinguished from that of a continuous pressure.

If the velocity of the molecules is given, and the number varied, thence since each molecule, on an average, strikes the side of the vessel the same number of times, and with an impulse of the same magnitude, each will contribute an equal share to the whole pressure. The pressure in a vessel of given size is therefore proportional to the number of molecules in it, that is, to the quantity of gas in it.

This is the complete dynamical explanation of the fact discovered by Robert Boyle, that the pressure of air is proportional to its density. It shows also that, of different portions of gas forced into a vessel, each produces its own part of the pressure independently of the rest, and this whether these portions be of the same gas or not.

Let us next suppose that the velocity of the molecules is increased. Each molecule will now strike the sides of the vessel a greater number of times in a second, but besides this, the impulse of each blow will be increased in the same proportion, so that the part of the pressure due to each molecule will vary as the *square* of the velocity. Now, the increase of the square of velocity corresponds, in our theory, to a rise of temperature, and in this way we can explain the effect of

warming the gas, and also the law discovered by Charles, that the proportional expansion of all gases between given temperatures is the same.

The dynamical theory also tells us what will happen if molecules of different masses are allowed to knock about together. The greater masses will go slower than the smaller ones, so that, on an average, every molecule, great or small, will have the same energy of motion.

The proof of this dynamical theorem, in which I claim the priority, has recently been greatly developed and improved by Dr. Ludwig Boltzmann. The most important consequence which flows from it is, that a cubic centimetre of every gas at standard temperature and pressure contains the same number of molecules. This is the dynamical explanation of Gay-Lussac's law of the equivalent volumes of gases. But we must now descend to particulars, and calculate the actual velocity of a molecule of hydrogen.

A cubic centimetre of hydrogen, at the temperature of melting ice and at a pressure of one atmosphere, weighs 0.00008954 gramme. We have to find at what rate this small mass must move (whether altogether or in separate molecules makes no difference) so as to produce the observed pressure on the sides of the cubic centimetre. This is the calculation which was first made by Dr. Joule, and the result is 1,859 metres per second. This is what we are accustomed to call a great velocity. It is greater than any velocity obtained in artillery practice. The velocity of other gases is less, as you will see by the table, but in all cases it is very great as compared with that of bullets.

We have now to conceive the molecules of the air in this hall flying about in all directions, at a rate of about seventeen miles in a minute.

If all these molecules were flying in the same direction, they would constitute a wind blowing at the rate of seventeen miles a minute, and the only wind which approaches this velocity is that which proceeds from the mouth of a cannon. How, then, are you and I able to stand here? Only because the molecules happen to be flying in different directions, so that those which strike against our backs enable us to support the storm which is beating against our faces. Indeed, if this molecular bombardment were to cease, even for an instant, our veins would swell, our breath would leave us, and we should, literally, expire. But it is not only against us or against the walls of the room that the molecules are striking. Consider the immense number of them, and the fact that they are flying in every possible direction, and you will see that they cannot avoid striking each other. Every time that two molecules come into collision, the paths of both are changed, and they go off in new directions. Thus each molecule is continually getting its course altered, so that in spite of its great velocity it may be a long time before it reaches any great distance from the point at which it set out.

I have here a bottle containing ammonia. Ammonia is a gas which you can recognize by its smell. Its molecules have a velocity of six hundred metres per second, so that, if their course had not been interrupted by striking against the molecules of air in the hall, every one in the most distant gallery would have smelt ammonia before I was able to pronounce the name of the gas. But, instead of this, each molecule of ammonia is so jostled about by the molecules of air, that it is sometimes going one way and sometimes another. It is like a hare which is always doubling, and, though it goes a great pace, it makes very little progress. Nevertheless, the smell of ammonia is now beginning to be perceptible at some distance from the bottle. The gas does diffuse itself through the air, though the process is a slow one, and, if we could close up every opening of this hall so as to make it air-tight, and leave every thing to itself for some weeks, the ammonia would become uniformly mixed through every part of the air in the hall.

This property of gases, that they diffuse through each other, was first remarked by Priestley. Dalton showed that it takes place quite independently of any chemical action between the inter-diffusing gases. Graham, whose researches were especially directed toward those phenomena which seem to throw light on molecular motions, made a careful study of diffusion, and obtained the first results from which the rate of diffusion can be calculated.

Still more recently, the rates of diffusion of gases into each other have been measured with great precision by Prof. Loschmidt, of Vienna.

He placed the two gases in two similar vertical tubes, the lighter gas being placed above the heavier, so as to avoid the formation of currents. He then opened a sliding-valve, so as to make the two tubes into one, and, after leaving the gases to themselves for an hour or so, he shut the valve, and determined how much of each gas had diffused into the other.

As most gases are invisible, I shall exhibit gaseous diffusion to you by means of two gases, ammonia and hydrochloric acid, which, when they meet, form a solid product. The ammonia, being the lighter gas, is placed above the hydrochloric acid, with a stratum of air between, but you will soon see that the gases can diffuse through this stratum of air, and produce a cloud of white smoke when they meet. During the whole of this process, no currents or any other visible motion can be detected. Every part of the vessel appears as calm as a jar of undisturbed air.

But, according to our theory, the same kind of motion is going on in calm air as in the inter-diffusing gases, the only difference being that we can trace the molecules from one place to another more easily when they are of a different nature from those through which they are diffusing.

If we wish to form a mental representation of what is going on among the molecules in calm air, we cannot do better than observe a swarm of bees, when every individual bee is flying furiously, first in one direction, and then in another, while the swarm, as a whole, either remains at rest, or sails slowly through the air.

In certain seasons, swarms of bees are apt to fly off to a great distance, and the owners, in order to identify their property when they find them on other people's ground, sometimes throw handfuls of flour at the swarm. Now, let us suppose that the flour thrown at the flying swarm has whitened those bees only which happened to be in the lower half of the swarm, leaving those in the upper half free from flour.

If the bees still go on flying hither and thither in an irregular manner, the floury bees will be found in continually increasing proportions in the upper part of the swarm, till they have become equally diffused through every part of it. But the reason of this diffusion is not because the bees were marked with flour, but because they are flying about. The only effect of the marking is to enable us to identify certain bees.

We have no means of marking a select number of molecules of air, so as to trace them after they have become diffused among others, but we may communicate to them some property by which we may obtain evidence of their diffusion.

For instance, if an horizontal stratum of air is moving horizontally, molecules diffusing out of this stratum, into those above and below, will carry their horizontal motion with them, and so tend to communicate motion to the neighboring strata, while molecules diffusing out of the neighboring strata into the moving one will tend to bring it to rest. The action between the strata is somewhat like that of two rough surfaces, one of which slides over the other, rubbing on it. Friction is the name given to this action between solid bodies; in the case of fluids it is called internal friction or viscosity.

It is in fact only another kind of diffusion—a lateral diffusion of momentum, and its amount can be calculated from data derived from observations of the first kind of diffusion, that of matter. The comparative values of the viscosity of different gases were determined by Graham in his researches on the transpiration of gases through long, narrow tubes, and their absolute values have been deduced from experiments on the oscillation of disks by Oscar Meyer and myself.

Another way of tracing the diffusion of molecules through calm air is to heat the upper stratum of the air in a vessel, and so observe the rate at which this heat is communicated to the lower strata. This, in fact, is a third kind of diffusion—that of energy, and the rate at which it must take place was calculated from data derived from experiments on viscosity before any direct experiments on the conduction of heat had been made. Prof. Stefan, of Vienna, has recently, by a very delicate method, succeeded in determining the conductivity of



air, and he finds it, as he tells us, in striking agreement with the value predicted by the theory.

All these three kinds of diffusion—the diffusion of matter, of momentum, and of energy—are carried on by the motion of the molecules. The greater the velocity of the molecules, and the farther they travel before their paths are altered by collision with other molecules, the more rapid will be the diffusion. Now, we know already the velocity of the molecules, and therefore by experiments on diffusion we can determine how far, on an average, a molecule travels without striking another. Prof. Clausius, of Bonn, who first gave us precise ideas about the motion of agitation of molecules, calls this distance the mean path of a molecule. I have calculated, from Prof. Loschmidt's diffusion experiments, the mean path of the molecules of four well-known gases. The average distance traveled by a molecule between one collision and another is given in the table. It is a very small distance, quite imperceptible to us even with our best microscopes. Roughly speaking, it is about the tenth part of the length of a wave of light, which you know is a very small quantity. Of course the time spent on so short a path by such swift molecules must be very small. I have calculated the number of collisions which each must undergo in a second. They are given in the table, and are reckoned by thousands of millions. No wonder that the traveling power of the swiftest molecule is but small, when its course is completely changed thousands of millions of times in a second.

The three kinds of diffusion also take place in liquids, but the relation between the rates at which they take place is not so simple as in the case of gases. The dynamical theory of liquids is not so well understood as that of gases, but the principal difference between a gas and a liquid seems to be that, in a gas each molecule spends the greater part of its time in describing its free path, and is for a very small portion of its time engaged in encounters with other molecules, whereas in a liquid the molecule has hardly any free path, and is always in a state of close encounter with other molecules.

Hence, in a liquid, the diffusion of motion from one molecule to another takes place much more rapidly than the diffusion of the molecules themselves, for the same reason that it is more expeditious in a dense crowd to pass on a letter from hand to hand than to give it to a special messenger to work his way through the crowd. I have here a jar, the lower part of which contains a solution of copper sulphate, while the upper part contains pure water. It has been standing here since Friday, and you see how little progress the blue liquid has made in diffusing itself through the water above. The rate of diffusion of a solution of sugar has been carefully observed by Voit. Comparing his results with those of Loschmidt on gases, we find that about as much diffusion takes place in a second in gases as requires a day in liquids.

The rate of diffusion of momentum is also slower in liquids than

in gases, but by no means in the same proportion. The same amount of motion takes about ten times as long to subside in water as in air, as you will see by what takes place when I stir these two jars, one containing water and the other air. There is still less difference between the rates at which a rise of temperature is propagated through a liquid and through a gas.

In solids the molecules are still in motion, but their motions are confined within very narrow limits. Hence, the diffusion of matter does not take place in solid bodies, though that of motion and heat takes place very freely. Nevertheless, certain liquids can diffuse through colloid solids, such as jelly and gum, and hydrogen can make its way through iron and palladium.

We have no time to do more than mention that most wonderful molecular motion which is called electrolysis. Here is an electric current passing through acidulated water, and causing oxygen to appear at one electrode, and hydrogen at the other. In the space between, the water is perfectly calm, and yet two opposite currents of oxygen and of hydrogen must be passing through it. The physical theory of this process has been studied by Clausius, who has given reasons for asserting that in ordinary water the molecules are not only moving, but every now and then striking each other with such violence that the oxygen and hydrogen of the molecules part company, and dance about through the crowd, seeking partners which have become dissociated in the same way. In ordinary water these exchanges produce, on the whole, no observable effect, but no sooner does the electromotive force begin to act, than it exerts its guiding influence on the unattached molecules, and bends the course of each toward its proper electrode, till the moment when, meeting with an unappropriated molecule of the opposite kind, it enters again into a more or less permanent union with it till it is again dissociated by another shock. Electrolysis, therefore, is a kind of diffusion assisted by electromotive force.

Another branch of molecular science is that which relates to the exchange of molecules between a liquid and a gas. It includes the theory of evaporation and condensation, in which the gas in question is the vapor of the liquid, and also the theory of the absorption of a gas by a liquid of a different substance. The researches of Dr. Andrews on the relations between the liquid and the gaseous state have shown us that, though the statements in our own elementary text-books may be so neatly expressed that they appear almost self-evident, their true interpretation may involve some principle so profound that, till the right man has laid hold of it, no one ever suspects that any thing is left to be discovered.

These, then, are, some of the fields from which the data of molecular science are gathered. We may divide the ultimate results into three ranks, according to the completeness of our knowledge of them.

To the first rank belong the relative masses of the molecules of different gases, and their velocities in metres per second. These data are obtained from experiments on the pressure and density of gases, and are known to a high degree of precision.

In the second rank we must place the relative size of the molecules of different gases, the length of their mean paths, and the number of collisions in a second. These quantities are deduced from experiments on the three kinds of diffusion. Their received values must be regarded as rough approximations till the methods of experimenting are greatly improved.

There is another set of quantities which we must place in the third rank, because our knowledge of them is neither precise, as in the first rank, nor approximate, as in the second, but is only as yet of the nature of a probable conjecture. These are the absolute mass of a molecule; its absolute diameter, and the number of molecules in a cubic centimetre. We know the relative masses of different molecules with great accuracy, and we know their relative diameters approximately. From these we can deduce the relative densities of the molecules themselves. So far we are on firm ground.

The great resistance of liquids to compression makes it probable that their molecules must be at about the same distance from each other as that at which two molecules of the same substance in the gaseous form act on each other during an encounter. This conjecture has been put to the test by Lorenz Meyer, who has compared the densities of different liquids with the calculated relative densities of the molecules of their vapors, and has found a remarkable correspondence between them.

Now, Loschmidt has deduced from the dynamical theory the following remarkable proportion: As the volume of a gas is to the combined volume of all the molecules contained in it, so is the mean path of a molecule to one-eighth of the diameter of a molecule.

Assuming that the volume of the substance, when reduced to the liquid form, is not much greater than the combined volume of the molecules, we obtain from this proportion the diameter of a molecule. In this way Loschmidt, in 1865, made the first estimate of the diameter of a molecule. Independently of him and of each other, Mr. Stoney in 1868, and Sir W. Thomson, in 1870, published results of a similar kind, those of Thomson being deduced not only in this way, but from considerations derived from the thickness of soap-bubbles, and from the electric properties of metals.

According to the table, which I have calculated from Loschmidt's data, the size of the molecules of hydrogen is such that about two million of them in a row would occupy a millimetre, and a million million million million of them would weigh between four and five grammes!

In a cubic centimetre of any gas at standard pressure and tem-

perature, there are about nineteen million million million molecules. All these numbers of the third rank are, I need not tell you, to be regarded as at present conjectural. In order to warrant us in putting any confidence in numbers obtained in this way, we should have to compare together a greater number of independent data than we have as yet obtained, and to show that they lead to consistent results.

Thus far, we have been considering molecular science as an inquiry into natural phenomena. But, though the professed aim of all scientific work is to unravel the secrets of Nature, it has another effect, not less valuable, on the mind of the worker. It leaves him in possession of methods which nothing but scientific work could have led him to invent, and it places him in a position from which many regions of Nature, besides that which he has been studying, appear under a new aspect. The study of molecules has developed a method of its own, and it has also opened up new views of Nature.

When Lucretius wishes us to form a mental representation of the motion of atoms, he tells us to look at a sunbeam shining through a darkened room (the same instrument of research by which Dr. Tyndall makes visible to us the dust we breathe), and to observe the motes which chase each other in all directions through it. This motion of the visible motes, he tells us, is but a result of the far more complicated motion of the invisible atoms which knock the motes about. In his dream of Nature, as Tennyson tells us, he

“saw the flaring atom-streams  
And torrents of her myriad universe,  
Running along the illimitable inane,  
Fly on to clash together again, and make  
Another and another frame of things  
Forever.”

And it is no wonder that he should have attempted to burst the bonds of Fate by making his atoms deviate from their courses at quite uncertain times and places, thus attributing to them a kind of irrational free-will, which on his materialistic theory is the only explanation of that power of voluntary action of which we ourselves are conscious.

As long as we have to deal with only two molecules, and have all the data given us, we can calculate the result of their encounter; but when we have to deal with millions of molecules, each of which has millions of encounters in a second, the complexity of the problem seems to shut out all hope of a legitimate solution.

The modern atomists have therefore adopted a method which is, I believe, new in the department of mathematical physics, though it has long been in use in the section of statistics. When the working members of Section F get hold of a report of the census, or any other document containing the numerical data of Economic and Social Science, they begin by distributing the whole population into groups, according to age, income-tax, education, religious belief, or criminal convictions.

The number of individuals is far too great to allow of their tracing the history of each separately, so that, in order to reduce their labor within human limits, they concentrate their attention on a small number of artificial groups. The varying number of individuals in each group, and not the varying state of each individual, is the primary datum from which they work.

This, of course, is not the only method of studying human nature. We may observe the conduct of individual men and compare it with that conduct which their previous character, and their present circumstances, according to the best existing theory, would lead us to expect. Those who practise this method endeavor to improve their knowledge of the elements of human nature in much the same way as an astronomer corrects the elements of a planet by comparing its actual position with that deduced from the received elements. The study of human nature by parents and school-masters, by historians and statesmen, is therefore to be distinguished from that carried on by registrars and tabulators, and by those statesmen who put their faith in figures. The one may be called the historical, and the other the statistical method.

The equations of dynamics completely express the laws of the historical method as applied to matter, but the application of these equations implies a perfect knowledge of all the data. But the smallest portion of matter which we can subject to experiment consists of millions of molecules, not one of which ever becomes individually sensible to us. We cannot, therefore, ascertain the actual motion of any one of these molecules, so that we are obliged to abandon the strict historical method, and to adopt the statistical method of dealing with large groups of molecules.

The data of the statistical method as applied to molecular science are the sums of large numbers of molecular quantities. In studying the relations between quantities of this kind, we meet with a new kind of regularity, the regularity of averages, which we can depend upon quite sufficiently for all practical purposes, but which can make no claim to that character of absolute precision which belongs to the laws of abstract dynamics.

Thus molecular science teaches us that our experiments can never give us any thing more than statistical information, and that no law deduced from them can pretend to absolute precision. But, when we pass from the contemplation of our experiments to that of the molecules themselves, we leave the world of chance and change, and enter a region where every thing is certain and immutable.

The molecules are conformed to a constant type with a precision which is not to be found in the sensible properties of the bodies which they constitute. In the first place, the mass of each individual molecule, and all its other properties, are absolutely unalterable. In the second place, the properties of all molecules of the same kind are absolutely identical.

Let us consider the properties of two kinds of molecules, those of oxygen and those of hydrogen.

We can procure specimens of oxygen from very different sources—from the air, from water, from rocks of every geological epoch. The history of these specimens has been very different, and, if, during thousands of years, difference of circumstances could produce difference of properties, these specimens of oxygen would show it.

In like manner we may procure hydrogen from water, from coal, or, as Graham did, from meteoric iron. Take two litres of any specimen of hydrogen, it will combine with exactly one litre of any specimen of oxygen, and will form exactly two litres of the vapor of water.

Now, if, during the whole previous history of either specimen, whether imprisoned in the rocks, flowing in the sea, or careering through unknown regions with the meteorites, any modification of the molecules had taken place, these relations would no longer be preserved.

But we have another and an entirely different method of comparing the properties of molecules. The molecule, though indestructible, is not a hard, rigid body, but is capable of internal movements, and when these are excited it emits rays, the wave-length of which is a measure of the time of vibration of the molecule.

By means of the spectroscope the wave-lengths of different kinds of light may be computed to within one ten-thousandth part. In this way it has been ascertained, not only that molecules taken from every specimen of hydrogen in our laboratories have the same set of periods of vibration, but that light, having the same set of periods of vibration, is emitted from the sun and from the fixed stars.

We are thus assured that molecules of the same nature as those of our hydrogen exist in those distant regions, or at least did exist when the light by which we see them was emitted.

From a comparison of the dimensions of the buildings of the Egyptians with those of the Greeks, it appears that they have a common measure. Hence, even if no ancient author had recorded the fact that the two nations employed the same cubit as a standard of length, we might prove it from the buildings themselves. We should also be justified in asserting that at some time or other a material standard of length must have been carried from one country to the other, or that both countries had obtained their standards from a common source.

But in the heavens we discover by their light, and by their light alone, stars so distant from each other, that no material thing can ever have passed from one to another; and yet this light, which is to us the sole evidence of the existence of these distant worlds, tells us also that each of them is built up of molecules of the same kinds as those which we find on earth. A molecule of hydrogen, for example, whether



in Sirius or in Arcturus, executes its vibrations in precisely the same time.

Each molecule, therefore, throughout the universe, bears impressed on it the stamp of a metric system as distinctly as does the metre of the Archives of Paris, or the double royal cubit of the Temple of Karnac.

No theory of evolution can be formed to account for the similarity of molecules, for evolution necessarily implies continuous change, and the molecule is incapable of growth or decay, of generation or destruction.

None of the processes of Nature, since the time when Nature began, have produced the slightest difference in the properties of any molecule. We are therefore unable to ascribe either the existence of the molecules, or the identity of their properties, to the operation of any of the causes which we call natural.

On the other hand, the exact equality of each molecule to all others of the same kind gives it, as Sir John Herschel has well said, the essential character of a manufactured article, and precludes the idea of its being eternal and self-existent.

Thus we have been led, along a strictly scientific path, very near to the point at which Science must stop. Not that Science is debarred from studying the internal mechanism of a molecule which she cannot take to pieces, any more than from investigating an organism which she cannot put together. But, in tracing back the history of matter, Science is arrested when she assures herself, on the one hand, that the molecule has been made, and on the other that it has not been made by any of the processes we call natural.

Science is incompetent to reason upon the creation of matter itself out of nothing. We have reached the utmost limit of our thinking faculties when we have admitted that because matter cannot be eternal and self-existent it must have been created.

It is only when we contemplate, not matter in itself, but the form in which it actually exists, that our mind finds something on which it can lay hold.

That matters such, should have certain fundamental properties—that it should exist in space and be capable of motion, that its motion should be persistent, and so on, are truths which may, for any thing we know, be of the kind which metaphysicians call necessary. We may use our knowledge of such truths for purposes of deduction, but we have no data for speculating as to their origin.

But that there should be exactly so much matter and no more in every molecule of hydrogen is a fact of a very different order. We have here a particular distribution of matter—a *collocation*—to use the expression of Dr. Chalmers, of things which we have no difficulty in imagining to have been arranged otherwise.

The form and dimensions of the orbits of the planets, for instance,

are not determined by any law of Nature, but depend upon a particular collocation of matter. The same is the case with respect to the size of the earth, from which the standard of what is called the metrical system has been derived. But these astronomical and terrestrial magnitudes are far inferior in scientific importance to that most fundamental of all standards which forms the base of the molecular system. Natural causes, as we know, are at work, which tend to modify, if they do not at length destroy, all the arrangements and dimensions of the earth and the whole solar system. But though in the course of ages catastrophes have occurred, and may yet occur, in the heavens, though ancient systems may be dissolved and new systems evolved out of their ruins, the molecules out of which these systems are built—the foundation-stones of the material universe—remain unbroken and unworn.

They continue this day as they were created, perfect in number, and measure, and weight, and, from the ineffaceable characters impressed on them, we may learn that those aspirations after accuracy in measurement, truth in statement, and justice in action, which we reckon among our noblest attributes as men, are ours, because they are essential constituents of the image of Him who in the beginning created, not only the heaven and the earth, but the materials of which heaven and earth consist.

TABLE OF MOLECULAR DATA.

	Hydrogen.	Oxygen.	Carbonic Oxide.	Carbonic Acid.
Rank I.— { Mass of molecule (hydrogen = 1) } { Velocity (of mean square), metres per second at 0° C. }	1 1,859	16 465	14 497	22 396
Rank II.— { Mean path, tenth-metres. } { Collisions in a second (millions). }	965 17,750	560 7,646	482 9,489	379 9,720
Rank III.— { Diameter, tenth-metre. } { Mass, twenty-fifth grammes. }	5.8 46	7.6 736	8.3 644	9.3 1,012

TABLE OF DIFFUSION:  $\frac{(\text{centimetre})^2}{\text{second}}$  measure.

	Calculated.	Observed.	
H & O.....	0.7086	0.7214	Diffusion of matter observed by Loschmidt.
H & CO....	0.6519	0.6422	
H & CO <sup>2</sup> ...	0.5575	0.5558	
O & CO....	0.1807	0.1802	
O & CO <sup>2</sup> ...	0.1427	0.1409	
CO & CO <sup>2</sup> ...	0.1386	0.1406	
H.....	1.2990	1.49	Diffusion of momentum. Graham and Meyer.
O.....	0.1884	0.213	
CO.....	0.1748	0.212	
CO <sup>2</sup> .....	0.1087	0.117	Diffusion of temperature observed by Stefan.
Air.....	.....	0.256	
Copper.....	.....	1.077	
Iron.....	.....	0.183	Voit. Fick.
Cane-sugar in water	0.00000365		
Diffusion in a day	0.3114		
Salt in water.....	0.00000116		

## PAST AND FUTURE OF A CONSTELLATION.

BY CAMILLE FLAMMARION.

TRANSLATED FROM THE FRENCH, BY J. FITZGERALD, A. M.

THE notions hitherto entertained as to the stars and the heavens are destined to undergo a complete revolution. There are *no fixed stars*. Each one of those distant suns, flaming in infinitude, is swept along in a stupendous movement which the imagination can hardly conceive. Notwithstanding the countless millions of miles of space between them and us, making them appear to us only as luminous points, whereas they are as great as our own sun, and thousands and millions of times greater than the earth, still, by means of the telescope and computation, astronomers have been able to come at them, and to demonstrate that they are all moving in every possible direction. The heavens are no longer motionless, nor can the constellations any longer be regarded as the symbol of the unchangeable. Take, for instance, Ursa Major, or the Great Bear, the first of the constellations to be observed and named. Who is there that has not taken that figure as the enduring symbol of the preëstablished harmony, the unalterable duration of the firmament? Well, that ancient constellation will be destroyed. Each one of the stars which constitute it is endowed with a movement of its own. The result is that, in course of time, the form of Ursa Major will be changed. It now somewhat resembles in outline a wagon, and hence its popular title everywhere of car, or wain, while the learned have given it the name of the Bear, that being the only animal known to the ancients as living in polar regions. As every one knows, the four stars arranged in the form of a quadrilateral are supposed to represent the four wheels, and the three stars in the front of the figure three horses. But the proper movement of the separate stars will alter this arrangement: it will bring the foremost horse to a point back of where he now is, while the other two will move onward. As for the two hinder wheels, they will proceed in contrary directions. When we know the annual value of the displacement of each of these seven stars, we can calculate their future relative positions. This I have done, and I here lay before the reader the curious results of my calculations.

In order to get an exact account of the difference in the form of this constellation, which will be observable at a given time, let us first portray its present state.

The Arabs gave these seven famous stars names which are sometimes applied to them still. Beginning with the hind off-wheel, and then taking in the order indicated by the Greek letters ( $\beta$ ,  $\gamma$ ,  $\delta$ ,  $\epsilon$ ,  $\zeta$ ,  $\eta$ ) the other wheels and the horses, the Arab names are as follows: Dubhe,

Merak, Phegda, Megrez, Alioth, Mizar, and Ackair. The last is the name given to the foremost horse. Persons possessed of good visual powers can discern above the second horse, Mizar, a small star which is called *the Postilion*. But these names are seldom employed in our times, the usual custom being to designate the seven principal stars of Ursa Major by the first seven letters of the Greek alphabet, as shown in the diagram. All these stars are of the second magnitude, except Delta (Fig. 1), which is of the third.

In the diagram, the arrows show the mean direction in which each of the seven stars moves. It will be seen that, of the seven, the first

FIG. 1.

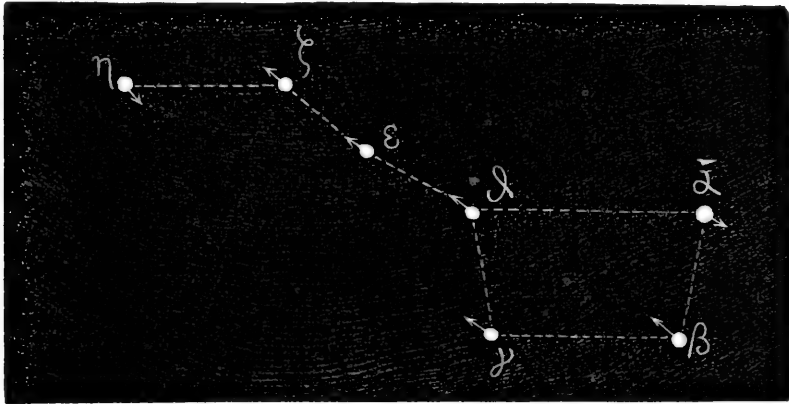

THE SEVEN STARS OF URSA MAJOR IN THEIR PRESENT POSITIONS.

and the last, Alpha and Eta, are moving in a direction contrary to that of the other five. It must be added that they have not all the same velocity. Eta, for example, moves rapidly; Epsilon slowly; and so on with the others.

The quantity of their annual proper movements in right ascension, and in polar distance, is given for each of the seven stars in the following table:

	R. A.	P. D.
Alpha (α)	- 0".013	+ 0".09
Beta (β)	+ 0".015	- 0".03
Gamma (γ)	+ 0".016	+ 0".02
Delta (δ)	+ 0".019	+ 0".06
Epsilon (ε)	+ 0".017	+ 0".06
Zeta (ζ)	+ 0".020	+ 0".04
Eta (η)	- 0".033	+ 0".03

In consequence of these proper movements, the relative distances between the stars of the constellation are ever changing. But, as this change only amounts to a few seconds in a century, many centuries must elapse before it is perceptible to the naked eye. Our human generations, our dynasties, nay, even our nations, are not sufficiently long-lived to measure this change.

We have here to deal with astronomical quantities, and, to appre-

ciate these, we must choose terms which correspond with them. The earth has but one measure of time that can be employed here, viz., its great year, the precession of its equinoxes—a slow revolution of the globe, which is completed in more than 25,000 years. A period like that might serve as a basis of measurement in geology and in sidereal astronomy. Taking, then, four of these periods—in round numbers 100,000 years—we ought, after that length of time, to have a sensible difference in the aspect of the heavens; and, in fact, on computation, I find that in this interval—which in the history of the stars is but a brief span—all the present constellations will be broken up.

In Fig. 2 I give the geometrical results of my calculations as to the proper movements of the stars in Ursa Major. Here is to be seen the shape which that constellation will wear 100,000 years hence. There is nothing like a wagon in this new figure. Alpha has moved downward and ranged itself on the right of Beta, and both of these lie on one line with Gamma, and even with Eta. Delta, Epsilon, and Zeta,

FIG. 2.

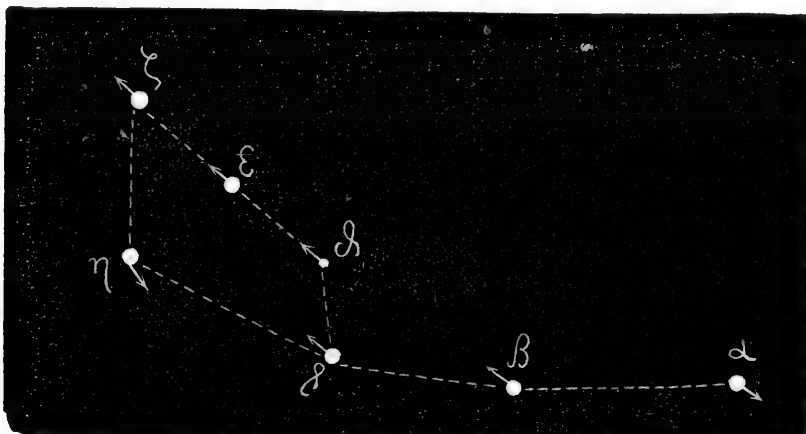

URSA MAJOR 100,000 YEARS HENCE.

are seen ranged on another line. If, in that distant epoch, the languages of terrestrial man shall still give to this constellation the title of the Wain, no one will be able to understand why. In considering what a mighty change it is destined to undergo in the future, the question arises, How long has it worn the shape in which it is familiar to us, and how did it look ages ago? One hundred thousand years ago there were, as yet, in all probability, no human beings on the earth, and the antediluvian monsters were the only creatures that could then view the starry sky.

Still, some of the older planets—Mars, Jupiter, Saturn, Uranus, and Neptune—were, no doubt, inhabited even then; and, as the heavens have the same appearance when viewed from them as from the earth, the dwellers in those worlds saw Ursa Major as it appeared in those days. All that we have to do, in order to find the position of each of the seven stars 100,000 years ago, is to move them back from their

present positions as far as they were moved forward in our second diagram. The result is a figure having no resemblance to either of the others. It is a sort of cross, with Beta at the point of intersection, Alpha marking the extremity of the left arm, and Gamma that of the right; Beta the top, Epsilon, Zeta, and Eta, the stem. Eta was, properly speaking, not yet in association with the other six. For the rest, on analyzing the movement of these stars, we see that five of them, Beta, Gamma, Delta, Epsilon, and Zeta, are associated together by a common tie. They are a group of friends: they move on with one accord, and, as will be seen, maintain the same relative position to one another. Alpha and Eta are only intruders, and, though they happen just at present to be with the group, they really have nothing to do with it. Look at Fig. 2: Alpha, which is ever

FIG. 3.

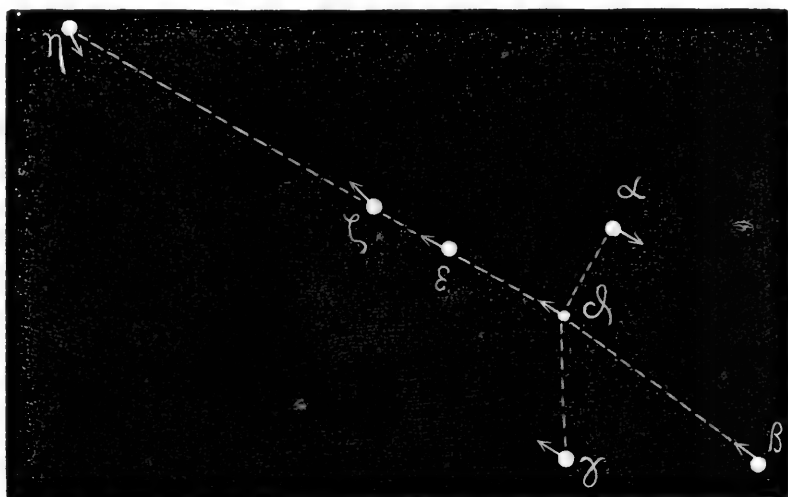

URSA MAJOR 100,000 YEARS AGO.

moving toward the right, will, in time, quit the group for good. On the other hand, Fig. 3 shows Eta coming in on the left; previously that star had no relation at all to the five.

The remarks just made with regard to the secular transformation of Ursa Major might be applied to all the other constellations. We have selected that one, because it is the best known of all, and one of the most characteristic. To sum up: we find that a knowledge of the proper movements of the stars completely transforms our common notions about the fixity of the heavens. The stars move in all directions through the endless realms of space, and as the aspect of the heavens changes, so does the constitution of the universe also change from age to age, undergoing innumerable metamorphoses.—*Revue Scientifique*.



## REPLIES TO CRITICISMS.

By HERBERT SPENCER.

## I.

WHEN made by a competent reader, an objection usually implies one of two things. Either the statement to which he demurs is wholly or partially untrue; or, if true, it is presented in such a way as to permit misapprehensions. A need for some change or addition is in any case shown.

Not recognizing the errors alleged, but thinking rather that misapprehensions cause the dissent of those who have attacked the metaphysico-theological doctrines held by me, I propose here to meet, by explanations and arguments, the chief objections they have urged: partly with the view of justifying these doctrines, and partly with the view of guarding against the incorrect interpretations which it appears are apt to be made.

It may be thought that the pages of a periodical intended for general reading are scarcely fit for the treatment of these highly-abstract questions. There is now, however, so considerable a class interested in them, and they are everywhere felt to be so deeply involved with the great changes of opinion in progress, that I have ventured to hope for readers outside the circle of those who occupy themselves with philosophy.

Of course the criticisms to be noticed I have selected, either because of their intrinsic force, or because they come from men whose positions or reputations give them weight. To meet more than a few of my opponents is out of the question.

Let me begin with a criticism contained in the sermon preached by the Rev. Principal Caird before the British Association on the occasion of its meeting in Edinburgh, in August, 1871. Expressed with a courtesy which, happily, is now less rare than of yore in theological controversy, Dr. Caird's objection might, I think, be admitted without involving essential change in the conclusion demurred to; while it might be shown to tell with greater force against the conclusions of thinkers classed as orthodox, Sir W. Hamilton, and Dean Mansel, than against my own. Describing this as set forth by me, Dr. Caird says:

“His thesis is, that the provinces of science and religion are distinguished from each other as the known from the unknown and unknowable. This thesis is maintained mainly on a critical examination of the nature of human intelligence, in which the writer adopts and carries to its extreme logical results the doctrine of the relativity of human knowledge which, propounded by Kant, has been reproduced with special application to theology by a famous school of

philosophers in this country. From the very nature of human intelligence, it is attempted to be shown that it can only know what is finite and relative, and that therefore the absolute and infinite the human mind is, by an inherent and insuperable disability, debarred from knowing. . . . May it not be asked, for one thing, whether, in the assertion, as the result of an examination of the human intellect, that it is incapable of knowing what lies beyond the finite, there is not involved an obvious self-contradiction? The examination of the mind can be conducted only by the mind, and if the instrument be, as is alleged, limited and defective, the result of the inquiry must partake of that defectiveness. Again, does not the knowledge of a limit imply already the power to transcend it? In affirming that human science is incapable of crossing the bounds of the finite world, is it not a necessary presupposition that you who so affirm have crossed these bounds?"

That this objection is one I am not disinclined to recognize, will be inferred when I state that it is one I have myself raised. While preparing the second edition of the "Principles of Psychology," I found, among my memoranda, a note which still bore the wafers by which it had been attached to the original manuscript (unless, indeed, it had been transferred from the MS. of "First Principles," which its allusions seems to imply). It was this:

"I may here remark, in passing, that the several reasonings, including the one above quoted, by which Sir William Hamilton would demonstrate the pure relativity of our knowledge—reasonings which clearly establish many important truths, and with which in the main I agree—are yet capable of being turned against himself, when he definitively concludes that it is impossible for us to know the absolute. For, to positively assert that the absolute cannot be known is, in a certain sense, to assert a *knowledge* of it—is to *know* it as *unknowable*. To affirm that human intelligence is confined to the conditioned is to put an *absolute limit* to human intelligence, and implies *absolute knowledge*. It seems to me that the 'learned ignorance' with which philosophy ends must be carried a step further; and, instead of positively saying that the absolute is unknowable, we must say that we cannot tell whether it is knowable or not."

Why I omitted this note I cannot now remember. Possibly it was because reconsideration disclosed the reply that might be made to the contained objection. For, while it is true that the intellect cannot prove its own competence, since it must postulate its competence in the course of the proof, and so beg the question, yet it does not therefore follow that it cannot prove its own incompetence, in respect of questions of certain kinds. Its inability in respect of such questions has two conceivable causes. It may be that the deliverances of Reason in general are invalid, in which case the incompetence of Reason to solve questions of a certain class is implied by its general incompetence; or it may be that the deliverances of Reason, valid within a certain range, themselves end in the conclusion that Reason is incapable beyond that range. So that, while there can be no proof of competence, because competence is postulated in each step of the demonstration, there may be proof of incompetence either (1) if the

successive deliverances forming the steps of the demonstration, by severally evolving contradictions, show their untrustworthiness, or, (2) if, being trustworthy, they lead to the result that, on certain questions, Reason cannot give any deliverance.

Reason leads both inductively and deductively to the conclusion that the sphere of Reason is limited. Inductively, this conclusion expresses the result of countless futile attempts to transcend this sphere—attempts to understand matter, motion, space, time, force, in their ultimate natures—attempts which, bringing us always to alternative impossibilities of thought, warrant the inference that such attempts will continue to fail, as they have hitherto failed. Deductively, this conclusion expresses the result of mental analysis, which shows us that the product of thought is in all cases a relation, identified as such or such; that the process of thought is the identification and classing of relations; that therefore Being in itself, out of relation, is unthinkable by us, as not admitting of being brought within the form of our thought. That is to say, deduction explains that failure of Reason established as an induction from many experiments. And to call in question the ability of Reason to give this verdict against itself, in respect of these transcendent problems, is to call in question its ability to draw valid conclusions from premises; which is to assert a general incompetence necessarily inclusive of the special incompetence.

Closely connected with the foregoing is a criticism from Dr. Mansel, on which I may here make some comments. In a note to his "Philosophy of the Conditioned" (page 39), he says:

"Mr. Herbert Spencer, in his work on 'First Principles,' endeavors to press Sir W. Hamilton into the service of Pantheism and Positivism together" (a somewhat strange assertion, by-the-way, considering that I reject them both), "by adopting the negative portion only of his philosophy—in which, in common with many other writers, he declares the absolute to be inconceivable by the mere intellect—and rejecting the positive portions, in which he most emphatically maintains that the belief in a personal God is imperatively demanded by the facts of our moral and emotional consciousness. . . . Sir W. Hamilton's fundamental principle is, that consciousness must be accepted entire, and that the moral and religious feelings, which are the primary source of our belief in a personal God, are in no way invalidated by the merely negative inferences which have deluded men into the assumption of an impersonal absolute. . . . Mr. Spencer, on the other hand, takes these negative inferences as the only basis of religion, and abandons Hamilton's great principle of the distinction between knowledge and belief."

Putting these statements in the order most convenient for discussion, I will deal first with the last of them. Instead of saying what he does, Dr. Mansel should have said that I decline to follow Sir W. Hamilton in confounding two distinct, and indeed radically opposed,

meanings of the word *belief*. This word "is habitually applied to dicta of consciousness for which no proof can be assigned: both those which are unprovable because they underlie all proof, and those which are unprovable because of the absence of evidence."<sup>1</sup> In the pages of this review for July, 1865, I exhibited this distinction as follows:

"We commonly say, 'we believe' a thing for which we can assign some preponderating evidence, or concerning which we have received some indefinable impression. We *believe* that the next House of Commons will not abolish Church-rates; or we *believe* that a person on whose face we look is good-natured. That is, when we can give confessedly-inadequate proofs or no proofs at all for the things we think, we call them 'beliefs.' And it is the peculiarity of these beliefs, as contrasted with cognitions, that their connections with antecedent states of consciousness may be easily severed, instead of being difficult to sever. But, unhappily, the word 'belief' is also applied to each of those temporarily or permanently indissoluble connections in consciousness, for the acceptance of which the only warrant is that it cannot be got rid of. Saying that I feel a pain, or hear a sound, or see one line to be longer than another, is saying that there has occurred in me a certain change of state; and it is impossible for me to give a stronger evidence of this fact than that it is present to my mind. . . . 'Belief' having, as above pointed out, become the name of an impression for which we can give only a confessedly-inadequate reason, or no reason at all, it happens that, when pushed hard respecting the warrant for any ultimate dictum of consciousness, we say, in the absence of all assignable reason, that we *believe* it. Thus the two opposite poles of knowledge go under the same name; and by the reverse connotations of this name, as used for the most coherent and least coherent relations of thought, profound misconceptions have been generated."

Now, that the belief which the moral and religious feelings are said to yield of a personal God is not one of the beliefs which are unprovable because they underlie all proof, is obvious. It needs but to remember that, in works on natural theology, the existence of a personal God is *inferred* from these moral and religious feelings, to show that it is not contained in these feelings themselves, or joined with them as an inseparable intuition. It is not a belief like the beliefs which I now have that this is daylight, and that there is open space before me—beliefs which cannot be proved because they are of equal simplicity with, and of no less certainty than, each step in a demonstration. Were it a belief of this most certain kind, argument would be superfluous: all races of men and every individual would have the belief in an inexpugnable form. Hence it is manifest that, confusing the two very different states of consciousness called belief, Sir W. Hamilton ascribes to the second a certainty that belongs only to the first.

Again, neither Sir W. Hamilton nor Dr. Mansel has enabled us to distinguish those "facts of our moral and emotional consciousness" which imperatively demand the belief in a personal God, from those facts of our (or of men's) "moral and emotional consciousness" which,

<sup>1</sup> "Principles of Psychology" (second edition, § 425, note).

in those having them, imperatively demand beliefs that Sir W. Hamilton would regard as untrue. A New-Zealand chief, discovering his wife in an infidelity, killed the man; the wife then killed herself that she might join her lover in the other world; and the chief thereupon killed himself that he might go after them to defeat this intention. These two acts of suicide furnish tolerably strong evidence that these New-Zealanders believed in another world to which they could go at will, and fulfill their desires as they did here. If they were asked the justification for this belief, and if the arguments by which they sought to establish it were not admitted, they might still fall back on emotional consciousness as yielding them an unshakable foundation for it. I do not see why a Feejee-Islander, adopting the Hamiltonian argument, should not justify by it his conviction that, after being buried alive, his life in the other world, forthwith commencing at the age he has reached in this, will similarly supply him with the joys of conquest and the gratifications of cannibalism. That he has a conviction to this effect stronger than the religious convictions current among civilized people is proved by the fact that he goes to be buried alive quite willingly; and, as we may presume that his conviction is not the outcome of a demonstration, it must be the outcome of some state of feeling—some “emotional consciousness.” Why, then, should he not assign the “facts” of his “emotional consciousness” as “imperatively demanding” this belief? Manifestly, this principle, that “consciousness must be accepted entire,” either obliges us to accept as true the superstitions of all mankind, or else obliges us to say that the consciousness of a certain limited class of cultivated people is alone meant. If things are to be believed simply because the facts of emotional consciousness imperatively demand them, I do not see why the actual existence of a ghost in a house is not inevitably implied by the intense fear of it that is aroused in the child or the servant.

Lastly, and chiefly, I have to deal with Dr. Mansel’s statement that “Mr. Spencer, on the other hand, takes these negative inferences as the only basis of religion.” This statement is exactly the reverse of the truth, since I have contended, against Hamilton and against him, that the consciousness of that which is manifested to us through phenomena is *positive*, and not *negative* as they allege, and that this positive consciousness supplies an indestructible basis for the religious sentiment (“First Principles,” § 26). Instead of giving here passages to show this, I may fitly quote the statement and opinion of a foreign theologian. M. le pasteur Grotz, of the Reformed Church at Nismes, writes thus :

“Is Science, then, the natural enemy of Religion? To preserve our religion, must we cry Science down? Why, Science, experimental Science, is now beginning to speak in favor of Religion; and it is Science that is about to reply at once to M. Vacherot and to M. Comte through the mouth of one of the thinkers of our age, Mr. Herbert Spencer.” . . . .

“Here Mr. Spencer discusses the theory of the *unconditioned*, by which word we are to understand God. The Scotch philosopher, Hamilton, and his disciple, Mr. Mansel, say with our French positivists, ‘We cannot affirm the positive existence of any thing whatever, except phenomena.’ Hamilton and his disciple differ from our countrymen only in this, that they bring in a ‘miraculous intervention,’ which enables us to believe in the existence of the unconditioned; and in virtue of this truly miraculous intervention the whole system of orthodoxy is set up again. Is it true that we can affirm nothing beyond phenomena? Mr. Spencer holds that in such an assertion there is grave error. The logical side of a question, as he very justly observes, is not the only one: there is also the psychological side; and, as we take it, he proves that the positive existence of the Absolute is a necessary *datum* of consciousness. . . .

“This is the basis of agreement between Religion and Science. In a chapter entitled ‘Reconciliation,’ Mr. Spencer establishes and develops this agreement on its true ground. . . . Mr. Spencer, by standing on the ground of logic and psychology, without recurring to supernatural intervention, has established the legitimacy, the necessity, and the everlasting permanency of religion itself.”

I turn next to what has been said by Dr. Shadworth H. Hodgson, in his essay on “The Future of Metaphysic,” published in the *Contemporary Review* for November, 1872. Remarking only, with respect to the agreements he expresses in certain doctrines of mine, that I value them as coming from a thinker of subtlety and independence, I will confine myself here to his disagreements. Dr. Hodgson, before giving his own view, briefly describes and criticises the views of Hegel and Comte, with both of whom he partly agrees and partly disagrees, and then proceeds to criticise the view set forth by me. After a preliminary brief statement of my position, to the wording of which I demur, he goes on to say:

“In his ‘First Principles,’ (Part I., second edition), there is a chapter headed ‘Ultimate Scientific Ideas,’ in which he enumerates six such ideas or groups of ideas, and attempts to show that they are entirely incomprehensible. The six are: 1. Space and Time; 2. Matter; 3. Rest and Motion; 4. Force; 5. Consciousness; 6. The Soul, or the Ego. Now, to enter at length into all of these would be an undertaking too large for the present occasion; but I will take the first of the six, and endeavor to show in its case the entire untenability of Mr. Spencer’s view; and, since the same argument may be employed against the rest, I shall be content that my case against them should be held to fail if my case should fail in respect to Space and Time.”

I am quite content to join issue with Dr. Hodgson on these terms; and will proceed to examine, one by one, the several arguments which he uses to show the invalidity of my conclusions. Following his criticism in the order he has chosen, I begin with the sentence following that which I have just quoted. The first part of it runs thus: “The metaphysical view of Space and Time is, that they are elements in all phenomena, whether the phenomena are presentations or representations.”

Whether, by “the metaphysical view,” is here meant the view of



Kant, whether it means Dr. Hodgson's own view, or whether the expression has a more general meaning, I have simply to reply that the metaphysical view is incorrect. Dealing with the Kantian version of this doctrine, that Space is a form of intuition, I have pointed out that only with certain classes of phenomena is Space invariably united; that Kant habitually considers phenomena belonging to the visual and tactual groups, with which the consciousness of Space is inseparably joined, and overlooks groups with which it is not inseparably joined. Though, in the adult, perception of sound has certain space-implications, mostly, if not wholly, acquired by individual experience; and though it would seem, from the instructive experiments of Mr. Spalding, that, in creatures born with nervous systems much more organized than our own are at birth, there is some innate perception of the side from which a sound comes; yet it is demonstrable that the space-implications of sound are not originally given with the sensation as its form of intuition. Bearing in mind the Kantian doctrine, that Space is the form of sensuous intuitions not only as *presented* but also as *represented*, let us examine critically our musical ideas. As I have elsewhere suggested to the reader—

“Let him observe what happens when some melody takes possession of his imagination. Its tones and cadences go on repeating themselves apart from any space-consciousness—they are not localized. He may or may not be reminded of the place where he heard them; this association is incidental only. Having observed this, he will see that such space-implications as sounds have are learned in the course of individual experience, and are not given with the sounds themselves. Indeed, if we refer to the Kantian definition of form, we get a simple and conclusive proof of this. Kant says form is ‘that which effects that the content of the phenomenon can be arranged under certain relations.’ How then can the content of the phenomenon we call sound be arranged? Its parts can be arranged in order of sequence—that is, in Time. But there is no possibility of arranging its parts in order of coexistence—that is, in Space. And it is just the same with odor. Whoever thinks that sound and odor have Space for their form of intuition may convince himself to the contrary by trying to find the right and left sides of a sound, or to imagine an odor turned the other way upward.”—(*Principles of Psychology*, § 399.)

As I thus dissent, not I think without good reason, from “the metaphysical view of Space and Time” as “elements in all phenomena,” it will naturally be expected that I dissent from the first criticism which Dr. Hodgson proceeds to deduce from it. Dealing first with the arguments I have used to show the incomprehensibility of Space and Time, if we consider them as objective, and stating in other words the conclusion I draw, that, “as Space and Time cannot be either non-entities nor the attributes of entities, we have no choice but to consider them as entities,” Dr. Hodgson continues :

“So far good. Secondly, he argues that they cannot be represented in thought as such real existences, because, ‘to be conceived at all, a thing must

be conceived as having attributes.' Now, here the metaphysical doctrine enables us to conceive them as real existences, and rebuts the argument for their inconceivability; for the other element, the material element, the feeling or quality occupying Space and Time, stands in the place and performs the function of the required attributes, composing, together with the space and time which is occupied, the empirical phenomena of perception. So far as this argument of Mr. Spencer goes, then, we are entitled to say that his case for the inconceivability of Space and Time as real existences is not made out."

Whether the fault is in me or not I cannot say, but I fail to see that my argument is thus rebutted. On the contrary, it appears to me substantially conceded. What kind of entity is that which can exist only when occupied by something else? Dr. Hodgson's own argument is a tacit assertion that Space *by itself* cannot be conceived as an existence; and this is all that I have alleged.

Dr. Hodgson deals next with the further argument, familiar to all readers, which I have added as showing the insurmountable difficulty in the way of conceiving Space and Time as objective entities: namely, that "all entities which we actually know as such are limited. . . . But of Space and Time we cannot assert either limitation or the absence of limitation." Without quoting at length the reasons Dr. Hodgson gives for distinguishing between Space as *perceived* and Space as *conceived*, it will suffice if I quote his own statement of the result to which they bring him: "So that Space and Time, as perceived, are not finite but infinite; as conceived, are not infinite but finite."

Most readers will, I think, be startled by the assertion that conception is less extensive in range than perception; but, without dwelling on this, I will content myself by asking in what case Space is perceived as infinite? Surely Dr. Hodgson does not mean to say that he can perceive the whole surrounding Space at once—that the Space behind is united in perception with the Space in front. Yet this is the necessary implication of his words. Taking his statement less literally, however, and not dwelling on the fact that in perception Space is habitually bounded by objects more or less distant, let us test his assertion under the most favorable conditions. Supposing the eye directed upward toward a clear sky; is not the Space then perceived laterally limited? The visual area, restricted by the visual apertures, cannot include in perception even 180° from side to side, and is still more confined in a direction at right angles to this. Even in the third direction, to which alone Dr. Hodgson evidently refers, it cannot properly be said that it is infinite in perception. Look at a position in the sky a thousand miles off. Now look at a position a million miles off. What is the difference in perception? Nothing. How, then, can an infinite distance be perceived, when these immensely unlike finite distances cannot be perceived as differing from one another, or from an infinite distance? Dr. Hodgson has used the

wrong word. Instead of saying that Space as perceived is infinite, he should have said that, in perception, Space is finite in two dimensions, and becomes *indefinite* in the third when this becomes great.

I come now to the paragraph beginning "Mr. Spencer then turns to the second or subjective hypothesis, that of Kant." This paragraph is somewhat difficult to deal with, for the reason that in it my reasoning is criticised both from the Kantian point of view and from Dr. Hodgson's own point of view. Dissenting from Kant's view, Dr. Hodgson says, "I hold that both Space and Time, and Feeling, or the material element, are equally and alike subjective, equally and alike objective." As I cannot understand this, I am unable to deal with those arguments against me which Dr. Hodgson bases upon it, and must limit myself to that which he urges on behalf of Kant. He says:

"But I think that Mr. Spencer's representation of Kant's view is very incorrect; he seems to be misled by the large term non-ego. Kant held that Space and Time were *in their origin* subjective, but when applied to the non-ego resulted in phenomena, and were the formal element in those phenomena, among which some were phenomena of the internal sense or ego, others of the external sense or non-ego. The non-ego to which the forms of Space and Time did not apply and did not belong was the Ding-an-sich, not the phenomenal non-ego. Hence the objective existence of Space and Time in phenomena, but not in the Ding-an-sich, is a consistent and necessary consequence of Kant's view of their subjective origin."

If I have misunderstood Kant, as thus alleged, then my comment must be that I credited him with an hypothesis less objectionable than that which he held. I supposed his view to be that Space, as a form of intuition belonging to the *ego*, is imposed by it on the *non-ego* (by which I understood the thing in itself) in the act of intuition. But now the Kantian doctrine is said to be that Space, originating in the subject, when applied to the *non-ego* results in phenomena (the *non-ego* meant being, in that case, necessarily the Ding-an-sich, or thing in itself); and that the phenomena so resulting, carrying with them the Space they have been endowed with, become objective existences along with the Space given to them by the *ego*. The subject having imposed Space as a form on the primordial *non-ego*, or thing in itself, and so created phenomena, this Space thereupon becomes an objective existence, independent of both the *ego* and the original thing in itself. To Dr. Hodgson this may seem a more tenable position than that which I ascribed to Kant; but to me it seems only a multiplication of inconceivabilities. I am content to leave it as it stands: not feeling my reasons for rejecting the Kantian hypothesis much weakened.<sup>1</sup>

<sup>1</sup> Instead of describing me as misunderstanding Kant on this point, Dr. Hodgson should have described Kant as having, in successive sentences, so changed the meanings of the words he uses, as to make either interpretation possible. At the outset of his "Critique of Pure Reason," he says: "The effect of an object upon the faculty of repre-

The remaining reply which Dr. Hodgson makes runs thus:

“But Mr. Spencer has a second argument to prove this inconceivability. It is this: ‘If Space and Time are forms of thought, they can never be thought of; since it is impossible for any thing to be at once the *form* of thought and the *matter* of thought.’ . . . An instance will show the fallacy best. Syllogism is usually held to be a form of thought. Would it be any argument for the inconceivability of syllogisms to say, they cannot be at once the form and the matter of thought? Can we not syllogize about syllogism? Or, more plainly still—no dog can bite himself, for it is impossible to be at once the thing that bites and the thing that is bitten.”

Had Dr. Hodgson quoted the whole of the passage from which he takes the above sentence; or had he considered it in conjunction with the Kantian doctrine to which it refers (namely, that Space survives in consciousness when all contents are expelled, which implies that then Space is the thing with which consciousness is occupied, or the *object* of consciousness), he would have seen that his reply has none of the cogency he supposes. If, taking his first illustration, he will ask himself whether it is possible to “syllogize about syllogism,” when syllogism has no content whatever, symbolic or other—has non-entity to serve for major, non-entity for minor, and non-entity for conclusion—he will, I think, see that syllogism, considered as surviving terms of every kind, cannot be syllogized about; the “pure form,” of reason (supposing it to be syllogism, which it is not), if absolutely discharged of all it contains, cannot be represented in thought, and therefore cannot be reasoned about. Following Dr. Hodgson to his second illustration, I must express my surprise that a metaphysician of his acuteness should have used it. For an illustration to have any value, the relation between the terms of the analogous case must have some parallelism to the relation between the terms of the case with which it is compared. Does Dr. Hodgson really think that the relation between a dog and the part of himself which he bites is like the relation between *matter* and *form*? Suppose the dog bites his tail. Now, the dog, as biting, stands, according to Dr. Hodgson, for the form as the containing mental faculty; and the tail as bitten

sensation, so far as we are affected by the said object, is sensation. That sort of intuition which relates to an object by means of sensation, is called an empirical intuition. The undetermined object of an empirical intuition, is called *phenomenon*. That which in the phenomenon corresponds to the sensation, I term its *matter*’ (here, remembering the definition just given of phenomenon, objective existence is manifestly referred to), ‘but that which effects that the content of the phenomenon can be arranged under certain relations, I call its *form*’ (so that *form* as here applied, refers to objective existence). ‘But that in which our sensations are merely arranged, and by which they are susceptible of assuming a certain form, cannot be itself sensation.’ (In which sentence the word *form* obviously refers to subjective existence.) At the outset, the ‘phenomenon’ and the ‘sensation’ are distinguished as objective and subjective respectively; and then, in the closing sentences, the *form* is spoken of in connection first with the one and then with the other, as though they were the same.”

stands for this mental faculty as contained. Now, suppose the dog loses his tail. Can the faculty as containing and the faculty as contained be separated in the same way? Does the mental form when deprived of all content, even itself (granting that it can be its own content), continue to exist in the same way that a dog continues to exist when he has lost his tail? Even had this illustration been applicable, I should have scarcely expected Dr. Hodgson to remain satisfied with it. I should have thought he would prefer to meet my argument directly, rather than indirectly. Why has he not shown the invalidity of the reasoning used in the "Principles of Psychology" (§ 399, second edition)? Having there quoted the statement of Kant, that "Space and Time are not merely forms of sensuous intuition, but *intuitions* themselves," I have written:

"If we inquire more closely, this irreconcilability becomes still clearer." Kant says: 'That which in the phenomenon corresponds to the sensation, I term its *matter*; but that which effects that the content of the phenomenon can be arranged under certain relations, I call its *form*.' Carrying with us this definition of form, as 'that which effects that the content . . . can be arranged under certain relations,' let us return to the case in which the intuition of Space is the intuition which occupies consciousness. Can the content of this intuition 'be arranged under certain relations' or not? It can be so arranged, or rather, it *is* so arranged. Space cannot be thought of save as having parts, near and remote, in this direction or the other. Hence, if that is the form of a thing 'which effects that the content . . . can be arranged under certain relations,' it follows that when the content of consciousness is the intuition of Space, which has parts 'that can be arranged under certain relations,' there must be a form of that intuition. What is it? Kant does not tell us—does not appear to perceive that there must be such a form; and could not have perceived this without abandoning his hypothesis that the space-intuition is primordial."

Now, when Dr. Hodgson has shown me how that "which effects that the content . . . can be arranged under certain relations" may also be that which effects its own arrangement under the same relations, I shall be ready to surrender my position; but, until then, no analogy drawn from the ability of a dog to bite himself will weigh much with me.

Having, as he considers, disposed of the reasons given by me for concluding that, considered in themselves, "Space and Time are wholly incomprehensible" (he continually uses on my behalf the word "inconceivable," which, by its unfit connotations, gives a wrong aspect to my position), Dr. Hodgson goes on to say:

"Yet Mr. Spencer proceeds to use these inconceivable ideas as the basis of his philosophy. For mark, it is Space and Time as we know them, the actual and phenomenal Space and Time, to which all these inconceivabilities attach. Mr. Spencer's result ought, therefore, logically to be—Skepticism. What is his actual result? Ontology. And how so? Why, instead of rejecting Space and Time as the inconceivable things he has tried to demonstrate them to be, he

substitutes for them an Unknowable, a something which they really are, though we cannot know it, and rejects that, instead of them, from knowledge."

This statement has caused me no little astonishment. That having before him the volume from which he quotes, so competent a reader should have so completely missed the meaning of the passages (§ 26) already referred to, in which I have contended against Hamilton and Mansel, makes me almost despair of being understood by any ordinary reader. In that section, I have, in the first place, contended that the consciousness of an Ultimate Reality, though not capable of being made a thought, properly so called, because not capable of being brought within limits, nevertheless remains as a mode of consciousness that is *positive*: is not rendered *negative* by the negation of limits. I have pointed out that—

"The error (very naturally fallen into by philosophers intent on demonstrating the limits and conditions of consciousness) consists in assuming that consciousness contains *nothing but* limits and conditions; to the entire neglect of that which is limited and conditioned. It is forgotten that there is something which alike forms the raw material of definite thought and remains after the definiteness which thinking gave to it has been destroyed," something which "ever persists in us as the body of a thought to which we can give no shape."

This *positive* element of consciousness it is, which, "at once necessarily indefinite and necessarily indestructible," I regard as the consciousness of the Unknowable Reality. Yet Dr. Hodgson says "Mr. Spencer proceeds to use these inconceivable ideas as the basis of his philosophy:" implying that such basis consists of negations, instead of consisting of that which persists *notwithstanding the negation of limits*. And then, beyond this perversion, or almost inversion, of meaning, he conveys the notion that I take, as the basis of philosophy, the "inconceivable ideas" "or self-contradictory notions" which result when we endeavor to comprehend Space and Time. He speaks of me as proposing to evolve substance out of form, or, rather, out of negations of forms—gives his readers no conception that the *Power* manifested to us is that which I regard as the Unknowable, while what we call Space and Time answer to the unknowable *nexus* of its manifestations. And yet the chapter from which I quote, and still more the chapter which follows it, makes this clear—as clear, at least, as I can make it by carefully-worded statements and restatements.

Philosophical systems, like theological ones, following the law of evolution in general, severally become in course of time more rigid, while becoming more complex and more definite; and they similarly become less alterable—resist all compromise, and have to be replaced by the more plastic systems that descend from them.



It is thus with the pure Empiricists and the pure Transcendentalists. Down to the present time disciples of Locke have continued to hold that all mental phenomena are interpretable as results of accumulated individual experiences; and, by criticism, have been led simply to elaborate their interpretations: ignoring the proofs of inadequacy. On the other hand, disciples of Kant, asserting this inadequacy, and led by perception of it to adopt an antagonist theory, have persisted in defending that theory under a form presenting fatal inconsistencies. And then, when there is offered a mode of reconciliation, the spirit of no-compromise is displayed: each side continuing to claim the whole truth. After it has been pointed out that all the obstacles in the way of the experiential doctrine disappear if the effects of ancestral experiences are joined with the effects of individual experiences, the old form of the doctrine is still adhered to, while Kantists persist in asserting that the *ego* is born with intuitional forms which are wholly independent of any thing in the *non-ego*, after it has been shown that the innateness of these intuitional forms may be so understood as to escape the insurmountable difficulties of the hypothesis as originally expressed.

I am led to say this by reading the remarks concerning my own views, made with an urbanity I hope to imitate, by Prof. Max Müller, in a lecture delivered at the Royal Institution last March.<sup>1</sup> Before dealing with the criticisms contained in this lecture, I must enter a demurrer against that interpretation of my views by which Prof. Max Müller makes it appear that they are more allied to those of Kant than to those of Locke. He says:

“Whether the prehistoric genesis of these congenital dispositions or inherited necessities of thought, as suggested by Mr. Herbert Spencer, be right or wrong, does not signify for the purpose which Kant had in view. In admitting that there is something in our mind which is not the result of our own *a posteriori* experience, Mr. Herbert Spencer is a thorough Kantian, and we shall see that he is a Kantian in other respects too. If it could be proved that nervous modifications, accumulated from generation to generation, could result in nervous structures, that are fixed in proportion as the outer relations to which they answer are fixed, we, as followers of Kant, should only have to put in the place of Kant’s intuitions of Space and Time ‘the constant space-relations expressed in definite nervous structures congenitally framed to act in definite ways, and incapable of acting in any other way.’ If Mr. Herbert Spencer had not misunderstood the exact meaning of what Kant calls the intuitions of Space and Time, he would have perceived that, barring his theory of the prehistoric origin of these intuitions, he was quite at one with Kant.”

On this passage let me remark, first, that the word “prehistoric,” ordinarily employed only in respect to human history, is misleading when applied to the history of Life in general; and his use of it leaves me in some doubt whether Prof. Max Müller has rightly conceived the hypothesis he refers to.

<sup>1</sup> See *Fraser’s Magazine* of May last.

My second comment is, that the description of me as "quite at one with Kant," "barring" the "theory of the prehistoric origin of these intuitions," curiously implies that it is a matter of comparative indifference whether the forms of thought are held to be *naturally generated* by intercourse between the organism and its environing relations, during the evolution of the lowest into the highest types, or whether such forms are held to be *supernaturally given* to the human mind, and are independent both of environing relations and of ancestral minds. But now, addressing myself to the essential point, I must meet the statement that I have "misunderstood the exact meaning of what Kant calls the intuitions of Space and Time," by saying that I think Prof. Max Müller has overlooked certain passages which justify my interpretation, and render his interpretation untenable. For Kant says "Space is *nothing else* than the form of all phenomena of the external sense;" further, he says that "Time is *nothing but* the form of our internal intuition;" and, to repeat words I have used elsewhere, "He distinctly shuts out the supposition that there are forms of the *non-ego* to which these forms of the *ego* correspond," by saying that "Space is not a conception which has been derived from outward experiences." Now, so far from being in harmony with, these statements are in direct contradiction to, the view which I hold, and seem to me absolutely irreconcilable with it. How can it be said that, "barring" a difference represented as trivial, I am "quite at one with Kant," when I contend that these subjective forms of intuition are moulded into correspondence with, and therefore derived from, some objective form or *nexus*; and therefore dependent upon it; while the Kantian hypothesis is that these subjective forms are not derived from the object, but exist independently in the *ego*, and are imposed by it on the *non-ego*? It seems to me that not only do Kant's words, as above given, exclude the view which I hold, but also that Kant could not consistently have held any such view. Rightly recognizing, as he did, these forms of intuition as innate, he was, from his stand-point, *obliged* to regard them as imposed on the matter of intuition in the act of perception. In the absence of the hypothesis that intelligence has been evolved, it was not possible for him to regard these subjective forms as having been derived from objective forms.

A disciple of Locke might, I think, say that the Evolution-view of our consciousness of Space and Time is essentially Lockian, with more truth than Prof. Max Müller can represent it as essentially Kantian. The Evolution-view is completely experiential. It differs from the original view of the experientialists by containing a great extension of it. With the relatively-small effects of individual experiences, it joins the relatively-vast effects of the experiences of antecedent individuals. But the view of Kant is avowedly and absolutely unexperiential. Surely this makes the predominance of kinship manifest.

In Prof. Max Müller's replies to my criticisms on Kant I cannot

see greater validity than in this affiliation to which I have demurred. One of his arguments is that which Dr. Hodgson has used, and which I have already answered; and I think that the others, when compared with the passages of the "Principles of Psychology" which they concern, will not be found adequate. I refer to them here chiefly for the purpose of pointing out that, when he speaks of me as bringing "three arguments against Kant's view," he understates the number. Let me close what I have to say on this disputed question, by quoting the summary of reasons I have given for rejecting the Kantian hypothesis:

"Kant tells us that Space is the form of all external intuition, which is not true. He tells us that the consciousness of Space continues when the consciousness of all things contained in it is suppressed; which is also not true. From these alleged facts he *infers* that Space is an *a priori* form of intuition. I say *infers*, because this conclusion is not presented in necessary union with the premises, in the same way that the consciousness of duality is necessarily presented along with the consciousness of inequality; but it is a conclusion voluntarily drawn for the purpose of explaining the alleged facts. And then, that we may accept this conclusion, which is not necessarily presented along with these alleged facts which are not true, we are obliged to affirm several propositions which cannot be rendered into thought. When Space is itself contemplated, we have to conceive it as at once the form of intuition and the matter of intuition, which is impossible. We have to unite that which we are conscious of as Space with that which we are conscious of as the *ego*, and contemplate the one as a property of the other; which is impossible. We have, at the same time, to disunite that which we are conscious of as Space, from that which we are conscious of as the *non-ego*, and contemplate the one as separate from the other; which is also impossible. Further, this hypothesis, that Space is 'nothing else' than a form of intuition belonging wholly to the *ego*, commits us to one of the two alternatives, that the *non-ego* is formless, and that its form produces absolutely no effect upon the *ego*—both of which alternatives involve us in impossibilities of thought."—*Principles of Psychology*, § 399.—*Advance Sheets from Fortnightly Review*.

---

## QUICKER THAN LIGHTNING.

THE Faithful have a tradition that Mohammed, on one occasion, in starting for heaven, upset a pitcher with his foot: he had ninety thousand interviews with the Most High, and, when he returned, the water was not yet spilled from the pitcher. It may be admitted that this was quick work, and that Mohammed was undoubtedly smart; but, when it comes to "interviewing," the Arabs must yield to the Yankees. In the laboratory of Columbia College, Prof. Rood has had interviews with one of the messengers of the Most High at a rate that leaves the prophet nowhere. Besides, with all respect to the hundred million believers, the Mussulman story is but a piece of Oriental fancy, while the Christian reports not only what he has actually seen, but can also

make others see. Our optics are none of the best, but we have seen the professor run down his ethereal game, and can attest that it was more exciting than a horse-race. Let us consider this "descent of man" into the regions of infinitesimal time.

Of all the curious things that science has revealed, none are so confounding to the ordinary reason as what has been learned respecting the order of Nature in its extremest aspect of minuteness. Objects fade away from the customary range of the senses, and we habitually think, what was long believed to be the fact, that there remains nothing more; or, that we find the edge and final termination of things but little beyond what is familiarly recognized. But we now understand that Nature is fathomless below as well as boundless above, and that, beneath the grasp of unaided sense, there are an inexhaustible wealth of wonders, a fixedness of relations, a definite play of interacting forces, and a sharp exactness in the working of law, which we could never infer from the coarser processes of the world of common experience.

As we are to speak of the briefest known duration of luminous effects, it will be proper first to recall how much is involved in the act of sight. When the man of experiment talks to us about what occurs in the thousandth of a second, he is, of course, dealing with something recognized, or which has affected both his body and his mind in that short space of time, and this is necessarily an illustration of how quickly his composite machinery can work. Then the agency which acts upon him must be taken into account, and also the cause of that agency, for they both belong to the same order of activities. When we look upon a source of illumination, as a candle or a star, we are affected by something that is done at those points. The light originates in the vibration of the molecules of matter. These vibrations are communicated to some medium which can convey the impulses at a demonstrated velocity of nearly 200,000 miles per second. The luminous waves strike the retina of the eye, and they are again translated into the molecular vibrations of nervous matter, and the physical influence is turned into a sensation by the organ of consciousness. The act of seeing thus involves the constitution and action of the visible object, the mode of movement of the force, the operation of the organ of vision, the changes of the nerve-line, and the cerebral act of recognition. There is a dynamic chain connecting thought and the object seen through a nether world of minuteness, but where all is correlated in a common scale of relations; and, whenever we see any thing, this whole train of transformations is implicated in the effect. The molecular tremors of Sirius, the ethereal thrills of space, and the rhythmic swing of the nervous elements, are but parts of a unified system of subsensible dynamics. Bearing in mind, then, what is involved in a single act of vision, let us now trace the course of experiment which has led to the latest results regarding its duration.

Phosphorus, the *light-bearer*, as its name implies, has the property, long supposed to be peculiar to it, of faintly shining in the dark. But, if a diamond is exposed to sunshine, and then withdrawn into darkness, it continues feebly luminous for a considerable time, and is, therefore, said to be *phosphorescent*. Other substances, as sulphuret of calcium, and sulphuret of barium, have also been long noted for this property, and recent researches have shown that, so far from being any thing peculiar, the same property is manifested in a much lower degree by a vast number of substances. The differences are in the time the phosphorescence continued after withdrawal from the sun's rays. It was found, in most instances, extremely short, only the small fraction of a second, and it became necessary to devise some means of measuring the time in different cases. A contrivance was necessary which should expose an object to the sun, and then jerk it quickly into total darkness, where it could be seen by the observer if it dragged any light along with it, for even the thousandth of a second.

FIG 1.

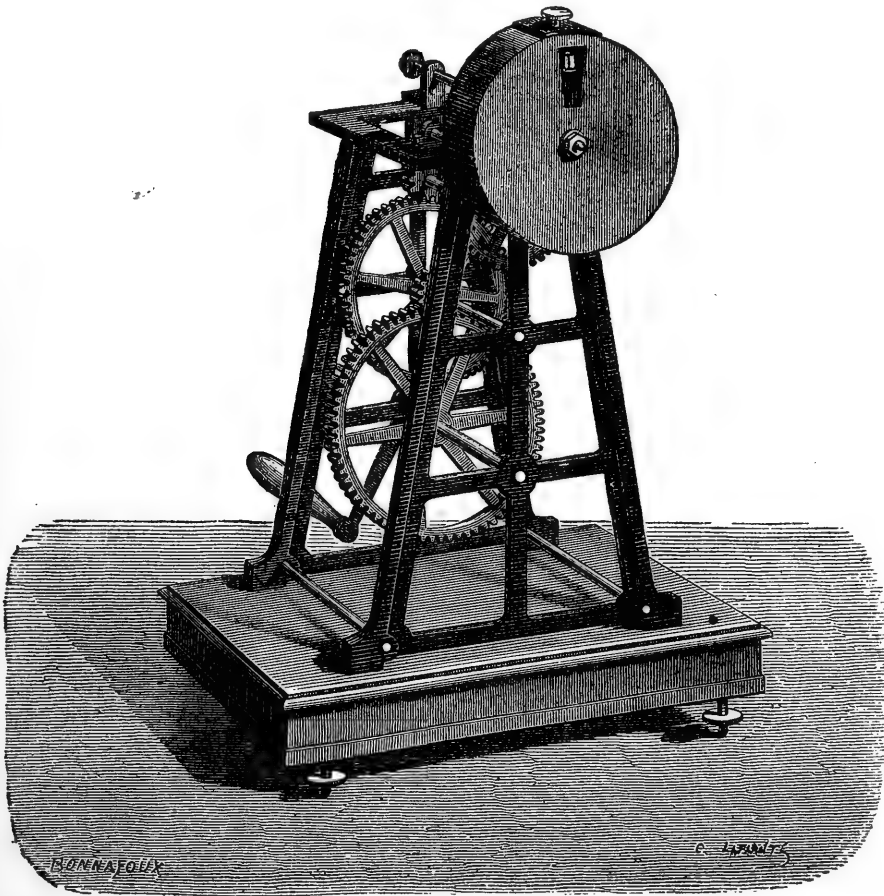

BECQUEREL'S PHOSPHOSCOPE.

A contrivance for this purpose was made by Edmund Becquerel, and called the *phosphroscope*. It consisted of a train of wheels and pinions (Fig. 1) for producing rapid revolving motion. There was a

hollow barrel or case at the top of the machine, pierced with an opening, within which, as seen in the figure, the object to be experimented with is attached to a fixed stand. On the opposite side of the case there is another opening in a corresponding position, not shown in the figure. The outer case does not revolve, but within it there is a pair of disks (Fig. 2) rigidly connected upon a spindle which is turned by the machinery. Each of these disks has four openings, those of the one being not opposite, but midway between those of the other. Of course, then, when these disks are inside the case, it is impossible to see through. The arrangement is then set up in the window of a darkened room, so that one side is turned toward the sun, and the

FIG. 2.

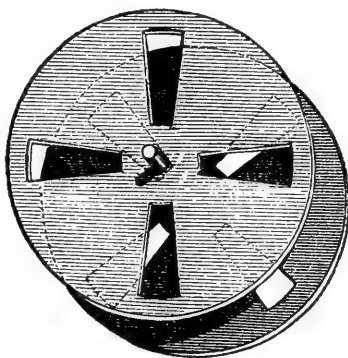

DISKS OF PHOSPHORSCOPE.

other toward the observer; and, when the disks are turned, the object is alternately exposed to the light from one side, and to the eye from the other; that is, it is seen in a moment after exposure to light, and the duration of the moment can be determined by the rapidity of the rotation. The object, therefore, if not phosphorescent, will never be seen by the observer, as it is always in darkness, except when it is hidden by the intervening disk. But, if its phosphorescence lasts as long as an eighth part of the time of one rotation, it will become visible in the darkness. Suppose, now, that the disks are made to revolve a hundred times in a second, and that the body observed is visible, it is then proved that its phosphorescence lasts the one eight-hundredth of a second, that being the time which elapses between its exposure to the sun and its exposure to the eye. When examined in this way, a very large number of bodies show traces of phosphorescence, although in some cases it is found to last no longer than the ten-thousandth part of a second.

The question was thus opened whether phosphorescence is not a general property of matter, and, to determine this, with the conditions of its manifestation, a more thorough investigation of the subject was needed. Prof. Rood proposed to undertake it, using, if possible, an instantaneous source of illumination—the electric spark. But, in en-



tering upon the inquiry, he soon found himself involved in preliminary difficulties with the spark itself. His phosphorescent investigations remain yet to be carried out, but the results obtained relative to the electric flash are of extreme interest. The full account of the research is given in a series of papers published in *Silliman's Journal*, and, if the reader finds the following statement insufficient in its details, he will know where to go for further explanations.

Since the time of Franklin, the lightning-flash has been regarded as a gigantic electric spark produced in the atmosphere; the inquiry, therefore, involved the nature of the meteorological discharge, as well as of the spark artificially produced. Various attempts to determine the duration of lightning have been made, with varying results. Faraday observed it, without any instruments for measuring the time, which *seemed* to last for a second, but he was doubtful if part of the effect was not due to the lingering phosphorescence of the cloud. Decharme observed the lightning-flashes from a distant storm, which also appeared to last for from a half to an entire second. Prof. Dove employed a revolving disk with colored sectors, and satisfied himself that single flashes of lightning often consisted of a number of instantaneous discharges. It is well known that, when a rapidly-moving train of cars is illuminated at night by lightning, it seems to stand still, that is, the duration of the flash is so brief that no motion of the train is perceptible while it lasts. The wheels are sharply defined as if perfectly motionless, but if they had a blurred aspect we should know that the illumination lasted sufficiently long to render the motion perceptible. Prof. Rood extemporized a simple contrivance for observing lightning, which acted upon this principle. It consisted of a white card-board disk, five inches in diameter, with a steel shawl-pin for an axis, on which it was made to revolve by striking the edge. He traced black figures near the circumference of the disk, and when it was in rapid motion these figures were sometimes seen as sharply as though they had been stationary, although they were often blurred as though the disk had moved through a few degrees during the act of discharge. He then cut narrow, radial apertures into the circumference of the disk, and observed the lightning through these openings. Here, again, the apertures were sometimes seen quite unchanged, but they were more frequently elongated into well-defined streaks some degrees in length. He afterward measured the average rate of rotation imparted to the disk in this way, and arrived at the conclusion that the lightning-flashes on the occasion referred to had a duration of about one five-hundredth of a second. Dissatisfied with the roughness of these observations, Prof. Rood arranged a small train of toothed wheels driven by a spring, which rotated a circular pasteboard disk with four open sectors. This instrument gave more regular and precise results; and, while it was shown that the flash sometimes lasts for a whole second, the suggestion of Dove was clearly verified that each flash "consisted of a consider-

able number of isolated and apparently instantaneous electrical discharges, the interval between the components being so small that, to the naked eye, they constituted a continuous act."

Several curious effects were observed in these experiments. Working with a disk having a single narrow opening, the multiple elements of the discharge were detected with great regularity, and Prof. Rood several times, instead of seeing the opening single, noticed that it had a form resembling the letter X or V, the lines in different positions of the disk having, as it were, got crossed in his eyes by their quick changes of position. On several occasions, when observing with the naked eye, the normal zigzag flashes lasted not less than a second, and the light seemed to pour steadily in a stream from the cloud to the earth. Observations made in the area occupied by a storm, out beyond its edge, and when it was quite distant, gave results that were identical, which the professor thinks furnishes an "argument in support of the hypothesis that zigzag lightning, heat and sheet lightning, etc., are really identical, being, in point of fact, due to the same cause but viewed under different conditions." As the result of these experiments, Prof. Rood concludes: "It is evident, from the foregoing, that the nature of the lightning-discharge is more complicated than has been generally supposed; it is usually, if not always, multiple in character, and the duration of the isolated constituents varies very much, ranging from intervals of time shorter than one one-thousandth of a second up to others at least as great as one-twentieth of a second; and, furthermore, what is singular, a variety of this kind may sometimes be found in the components of a single flash."

Such being the rough conclusions reached concerning the duration of the spark upon a grand scale, let us now consider the results of experiment upon it where all the conditions are in command. In 1835, Mr. Wheatstone attempted to measure the spark of a Leyden jar charged by a common frictional machine. The light from the spark was received upon a mirror mounted upon an axle capable of a high rate of revolution. The image of the spark, being thrown upon the mirror, was reflected to a distant point, and the time of the spark was inferred from the fixity or movement of the image. By using this arrangement, Mr. Wheatstone concluded that the discharge may take place within the millionth of a second; a result which was accepted by the scientific world for a quarter of a century. In 1858, a German named Feddersen, an accomplished physicist, dissatisfied with Wheatstone's results, entered upon a careful reëxamination of the subject. He used the revolving-mirror arrangement with frictional electricity; but, as Wheatstone had driven his machinery by *strings*, Feddersen adopted a train of *toothed wheels*, and with this form of mechanism he found that the image of the spark was drawn out by the revolving mirror into a whitish streak which indicated that the time of the discharge was not less than the twenty-five-thousandth of a second, while

it was inferred that the spark, instead of being a simple effect, is composite like the lightning, and is made up of several elements.

Such were the incomplete and discordant results of the investigation when it was undertaken by Prof. Rood. The arrangement he devised consisted of two parts, one for the production of the spark, and the other for measuring it. Fig. 3 represents the first combination. A galvanic battery was used to generate the electricity; this was connected with a large Ruhmkorff coil, which was again connected with a Leyden jar, and this with the electrodes for producing the spark, *S*,

FIG. 3.

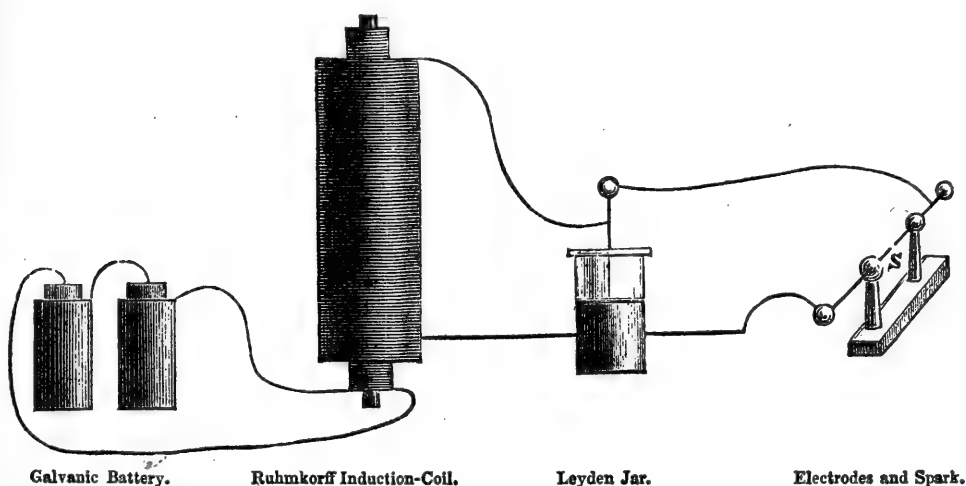

which were adjustable for varying its "striking distance." Connected with the wires between the battery and the coil was an automatic "interruptor" for breaking the circuit from three to six times in a second, by which the frequency of the discharges could be regulated. Leyden jars of different sizes could be used so as to give sparks of all degrees of strength and intensity.

In the second part of his arrangement, Prof. Rood, like his predecessors, employed a revolving mirror, turned by the gearing of Becquerel's phosphoscope (Fig. 1), with the addition of an extra wheel and a weight to drive it. With this he could get 350 revolutions of the mirror per second, with a smooth and uniform motion. In order to measure exactly the rate of rotation, the cylinder on the lowest wheel was made to wind up a fillet of paper, upon which dots were made by an electro-magnetic apparatus, regulated by a seconds-pendulum, when a simple calculation gave the rate of the wheel to which the mirror was attached, and the regularity of the train was thus put to a sharp test. The light of the spark *S* (Fig. 4), passing through an achromatic lens, *l*, struck the mirror, *m*, and was reflected upward, forming an image at *i*, on the plate of ground glass *G*. The image of the spark on the ground glass was viewed from above, and its position and form were carefully measured by several methods. Of course, if the

spark was *absolutely instantaneous*, its image thrown upon the ground glass would be exactly the same, whether the mirror was motionless or was revolving at the highest speed. But, if the spark had an appreciable duration, its image would be prolonged or drawn out into a streak, the length of which must depend upon the time of discharge. The rate of the mirror's rotation being known, also the distance,  $m$ ,  $i$ , and the length of the streak, it was easy to calculate the total duration of the spark.

FIG. 4.

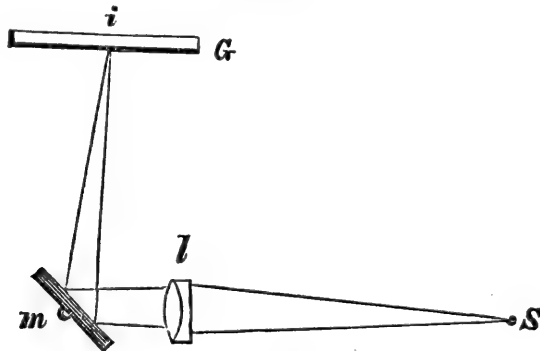

REVOLVING-MIRROR ARRANGEMENT.

Prof. Rood now had the subtle agent he was pursuing pretty effectually in his grasp, and the results that came out were very striking. The ordinary spark was found to be a highly-complex effect; to consist of diverse and successive elements, and, in fact, to have its periods and orderly history just like the geology of the globe. But, while the "vast durations" of Lyell and Dana are vague and inferential, these infinitesimal periods could be demonstrated with the greatest exactness. The previous discordant results were reconciled, Feddersen being justified in assigning a longer period for the total duration of the spark, and Wheatstone's time holding true of its elements.

With a Leyden jar of about a quart capacity (114.4 square inches of coating), and all the connections as short as possible, so as to offer the least amount of resistance to the electric flow, with brass balls as electrodes, with a striking distance of about the twenty-fifth of an inch, and the velocity of the mirror up to 223 per second, the image of the spark thrown upon the ground glass and viewed by the naked eye was drawn out into a streak one and a half or two inches long, the length, however, varying with the speed of the mirror. The aspects of the image are represented in Fig. 5. The first part was pure white, which shaded into a brownish-yellow tint, passing on into a pretty distinct green. When a polished plate of glass was substituted for the ground glass, and a small magnifier was used to observe the image, a series of bright points, on each side of the streak, became visible, in the positions indicated by the dots in Fig. 5. With high velocities, this succession of points was beautifully developed, and it consists of a series of separate discharges following the first. It was thus found that the

Leyden jar furnished a number of single sparks, each time the coil was excited, the number varying between one and thirty, according to circumstances. The whole proceeding consumed an interval of time often as great as one-fiftieth of a second; that is, the jar loaded up and discharged itself twenty or thirty times in that period. Prof. Rood found the number of elements of the spark to vary with its length, the nature of the electrodes, and the size of the jar. Short sparks are more complex than long ones, small jars give more than large ones, and metallic points a greater number than balls. The point to be determined was, the duration of the several elements of the spark, and especially of its quickest element. In one case of a discharge lasting the fiftieth of a second, it began with an ordinary spark, followed by a pale-violet light, lasting about one-sixtieth of a second, and then came a compact

FIG. 5.



IMAGES OF SPARK DRAWN OUT.

body of ten or twenty sparks, this last act continuing for about one two-hundredth of a second. The results of the inquiry are thus stated by Prof. Rood: "From the foregoing, then, it appears that, if a jar, having a metallic coating of about one hundred square inches, be connected, as above described, with an induction-coil, its discharge will be effected by a considerable number of acts, of which the first is by far the most intense. Further, the metallic particles, heated up by the first discharge to a white heat, almost instantly assume a lower temperature, marked by a corresponding change from white to brownish yellow; and, as their temperature continues to fall, the tint changes, in the case of brass electrodes, to green; in that of platinum, to a gray or violet-gray. These observations further demonstrated the fact that four ten-millionths of a second is an interval of time quite sufficient for the production of distinct vision."

It was also shown that the first act of the electric explosion, represented by the white band, lasted through an interval of time so short as to be immeasurable. It was proved that it could not occupy more

than the millionth or the half a millionth of a second, but how much less time it might occupy remained to be determined.

Prof. Rood now prepared for a more rigorous course of experiments. He used a small Leyden jar, with a surface of eleven inches, about equal to a moderate-sized wine-glass. To secure greater exactness of observation, he devised a peculiar micrometer, consisting of five lines ruled on a plate of glass smoked by lamp-black. This plate was placed between  $l$  and  $S$  (see Fig. 4), but quite near to the latter, and an image of the lines reflected from the mirror was formed on the clear glass at  $i$ . The lines were observed by a microscope magnifying ten diameters. In using this micrometer, the measurement was effected by noticing at what rate of the revolving mirror the lines in the image at  $i$  were *obliterated*, this obliteration being due to the circumstance that by the motion of the mirror the dark lines were superposed on the bright lines. The individual spark now produced was about a millionth of a second in duration, but the faint train was still observable. There was still the brilliant body of the spark appearing, first followed by a faint streak of less than one-hundredth the illuminating power of the first stage. The diagram, Fig. 6, represents the intensity

FIG. 6.

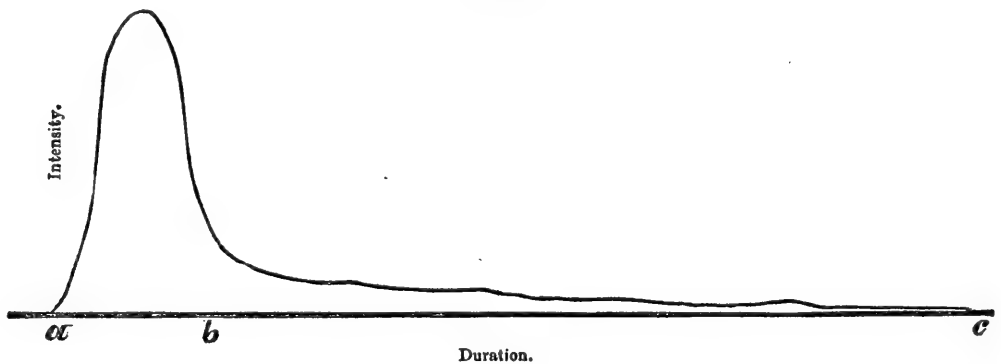

and time of the spark. The elevation, or peak,  $a b$ , shows the intensity of the first compact body of the spark, and the line  $a c$  the duration of the whole effect. The point was to get the time of  $a b$ , which Prof. Rood had proved must be regarded as a distinct act in the succession of effects. All precautions for observation being carefully made, the driving-weight was gradually increased, and the speed of the mirror carried up to 350 revolutions per second, when the lines of the image, which at first remained visibly as distinct as with a stationary mirror, became regularly less distinct, and at length vanished by the gradual superposition of the white and black lines. Prof. Rood says: "It was proved successively that the duration was less than eighty, sixty-eight, fifty-nine, fifty-five billionths of a second; and, finally, the lines, after growing fainter and fainter, entirely disappeared, giving as the result a duration of forty-eight billionths of a second." By reducing the striking distance, a still lower figure was



reached, so that the professor states that "the duration of the first act of the electrical discharge is in certain cases only forty billionths of a second, an interval of time just sufficient to enable a ray of light to travel over forty feet." The duration was twenty-five times smaller than had ever before been measured. In this infinitesimal portion of time a strong and distinct impression upon the retina is made, so that "the letters on a printed page are plainly to be seen; also, if a polariscope be used, the cross and rings around the axis of crystals can be observed with all their peculiarities." Nor is this all; "as the obliteration of the micrometric lines could only take place from the circumstance that the retina retains and combines a whole series of impressions whose joint duration is forty billionths of a second, it follows that a much smaller interval of time will suffice for vision. If we limit the number of views of the lines presented to the eye in a single case to ten, it would result that four billionths of a second is sufficient for human vision."

We saw at the outset how much an act of vision involves, and we have now some idea of how long it takes. If the discharge of the thunder-cloud occupies, as was stated, the one five-hundredth of a second, the "interviews" of our philosopher with the "amber-spirit" were at least fifty thousand times "quicker than lightning."



## THE EMOTIONAL LANGUAGE OF THE FUTURE.

MR. SPENCER recently called the attention, in a very interesting passage of his "Psychology," to those secondary signs of a feeling which are to be found in abortive attempts to conceal it. "A state of *mauvaise honte*," he well says, "otherwise tolerably well concealed, is indicated by an obvious difficulty in finding fit positions for the hands." A great mental agitation, though prevented from breaking out into violent expression, is pretty certain to betray itself in the awkward, shuffling movements which are made to curb and suppress it. Such indirect signs of emotion Mr. Spencer calls its secondary natural language.

The fact that many of our emotions now betray themselves only through the incompleteness of the effort of will to disguise them is not a little curious, and offers several lines of interesting inquiry. It at once suggests how very little play for emotional expression the conditions of modern society appear to allow. For it seems tolerably certain that the voluntary hiding of feeling is a late attainment in human development, and is forced on us simply by the needs of advancing civilization. Savages, for the most part, know little of concealing their passions, and this makes them so good a psychological

study. Children, too, who may be supposed to represent the earlier acquirements of the race, are proverbially unfettered in the expression of their sentiments. In like manner, in the various ranks of our civilized society, we see that, while a cultivated lady appears to all distant onlookers to have a mind dispassionate and undisturbed by agitating feelings, a west-country maid reveals her curiosity and wonder, her alternations of joy and misery, with scarcely a trace of compunction. If we go low enough down the social scale we find the freest utterance of feelings, and it is only when, in retracing our steps, we arrive at a certain stage of culture that we discover signs of an active emotional restraint. Where this self-control is defective we have Mr. Spencer's secondary emotional signs. Higher up, among a few specially cultivated persons, the acquisition of this power of concealment appears to be complete, and we have a type of mind capable of a prolonged external serenity unruffled by a gust of passionate impulse. The survey of these facts at once prompts the question whether the expression of our feelings by smile, vocal changes, and so on, is destined to disappear with a further advance of social organization. To attempt to answer such a question directly and briefly would perhaps betray too much confidence. We may, however, seek to define the various paths of inquiry to be pursued before a final answer can be arrived at, and to hint at the probabilities of the problem under its various aspects.

First of all, then, with respect to the distinctly unsocial feelings, the answer seems to be tolerably clear. It being generally allowed by biologists that the looks and gestures accompanying anger, jealousy, and pride, are simply survivals of hostile actions, the nascent renewal of an attitude preliminary to attack, it is natural that they should appear only in transitions of society from a barbaric to a civilized condition. When the age of destructive conflict, individual and racial, shall have become the curious research of antiquaries, it may be presumed that any bodily movements known to have grown out of these struggles will cease from sheer desuetude. Indeed, one may perhaps, without too optimistic a bias, refer to the fact that all the stronger manifestations of anger and malice have already become unfamiliar in real life, so that when we see their imitations on the stage they are apt to appear ridiculously forced. The better part of modern society has put such a ban on the ugly signs of rage that our only means of discovering traces of this passion in a man is some incompletely suppressed emotional movement, or some too violent effort to command the muscles of expression. After many more generations shall have practised the difficult art of noiselessly crushing out with the foot an incipient wrath, it will be hard if such offenses to the eye as frowning brow and scornful mouth do not entirely disappear.

But the progress of social refinement probably affects other expressions than those of the distinctly hostile sentiments. It tends to

confine within ever narrower limits all manifestations of unpleasant feeling. Since it is a grateful thing to witness pleasurable feeling, and painful to see the expression of suffering in another, a polite form of society does all it can to encourage the one and to suppress the other. A man is for the most part supposed to be able to obtain all needed sympathy, in his troubles, from his family and his intimate friends. Before the rest of the world he is expected to hide his grief and maintain a cheerful aspect. It is one of the delicate forms of sensibility, produced by a high culture, to be fearful of obtruding one's feelings on unconcerned onlookers. This growing perception of the vulgar aspects of uncontrolled emotional display appears to have much to do with the partial concealments of feeling of which Mr. Spencer speaks. But comparatively few persons are completely able to hide a sharp and sudden vexation, however public the occasion of experiencing it. An annoying piece of intelligence, affecting, it may be, one's matrimonial chances or equally dear ambitions, will very likely call up a momentary expression of dismay even in presence of a fashionable company. We wonder to how many persons it is still a necessity, under the smart of a sudden disappointment, to flee as soon as possible from all spectators, and relieve the pressure of emotion by a few energetic expletives, if not a spare shower of tears? We do not know how many ages it may require to discipline our species in a perfect concealment of painful feeling; but, at present, it looks as though we were passing through the hardest stages of this schooling.

One other influence which probably contributes to make emotion more and more private and invisible is the partial revival of the Stoical doctrine that all sentiment is a moral weakness. This idea appears to hold most sway in our own country, and especially among those classes who are most concerned to maintain a not too obvious gentility. A common supposition among young aspirants to social rank seems to be, that lofty breeding is best seen in a uniformly passionless and vacuous arrangement of the facial muscles. To appear interested in any object in his environment strikes the pseudo-aristocrat as a pitiable infirmity of vulgar minds. The ways in which this curious self-imposed check acts are at times very funny. We remember hearing Macready give a series of readings to a fashionably-dressed assembly, in a small provincial town, and we were much struck by the almost heroic efforts which many of the company made to conceal the emotion so powerfully aroused by the tragedian's art. Possibly English people are less impressible by scenic display and music than Continental nations. Whether this be so or not, it is very curious to contrast the perfectly apathetic aspect of an assembly at Covent Garden with the lively demonstrations of an audience at a Paris opera, or the deep, earnest absorption of the worshipers of Wagner at Berlin or Munich. This notion that it is the final attainment of civilization to appear impartially indifferent to every thing about one, and constantly to pre-

serve the semblance of an equanimity which knows nothing of the agitation of pleasure or pain, may be expected to give the last touch of refinement to emotional expression.

If these were all the facts bearing on the future of our emotional life, we might well inquire what effect the habitual suppression of emotional expression is likely to have on the quality of the emotions themselves. It is probably clear to everybody that our feelings are very much affected by the range of free expression accorded them. At least the violent intensity of a passion is destroyed by successful control of all the muscles, and, even if a slow, smouldering fire of hate or jealousy may coexist with a comparatively quiet exterior, the emotional force is in this case robbed of its glory. It would thus appear that, with social progress, as men are thrown more and more in each other's society, their feelings will undergo a very considerable transformation; some types of emotion disappearing, it may be, altogether, the rest being so mollified as to be scarcely recognizable as the venerable forms of human love, terror, and joy. But, oddly enough, we find another set of influences, due to the very same social conditions as the first, which tends to counteract these, fostering and deepening feeling, and encouraging its manifestations. Mr. Spencer thinks that the habit of expressing pleasure and pain arose as animals became gregarious. This condition exposed the members of the same flock to common experiences of danger, etc.; and in this way, from uttering the sounds of terror under like circumstances and at the same times, they would come to interpret them when given forth by their companions. At the same time the gregarious mode of life clearly made animals able to assist one another in a large variety of ways. Now, on this supposition, which seems extremely plausible, the habit of expressing feeling is an attainment of social life, and, so far from disappearing with the advance of this life, it should, one would think, go on developing. In point of fact, we see in a number of ways how social progress serves to enlarge the area of sympathetic feeling. As a man becomes more of a citizen, he is probably more and more desirous to be in unison of feeling and intention with his fellow-citizens, at least with that section of them whom he most respects. The sympathy he looks for presupposes, it is clear, some expression of his own feelings, and a responsive expression on the part of his neighbors. In this way, then, there are two tendencies of social culture curiously conflicting in their results. By virtue of the one a man seeks to repress feeling and not to obtrude it unnecessarily on his fellow-citizens. By force of the other he is ever craving with more and more vigor for a lively interchange of sentiments with others. What resultant, it may be asked, do these opposite forces produce?

Without trying to determine the precise direction of this compound effect, it may be just suggested that a kind of compromise between the opposing forces is frequently effected by means of lan-

guage. By this medium we may convey most minutely and accurately the fact of a feeling and define its nature, without bringing it forward as a vivid and naked reality. It is highly disagreeable to see a look of disgust in another's face, but we do not quite so strongly object to a man's telling us the cause of such a feeling and leaving us to imagine by inference the nature of the emotion itself. Language, while defining the precise variety of sentiment, contains also, in its ever-varying modulation of voice, its changes of pitch, intensity, and *timbre*, a large apparatus of proper emotional expression. Moreover, it seems fully allowable to accompany speech with a variety of other emotional signs which are looked on as silly and weak if presented independently. We rather expect conversation to be brightened by the many subtle changes of the facial muscles and the refined and subdued gestures peculiar to our nation. If a person habitually wears a half giggle, we are probably struck by the imbecility of this meaningless display. So too when a man meets us in the street looking evidently soured and retaliative, we rather wish he would reserve these unamiable exhibitions for his sympathetic friends. We have, in a word, grown intellectual much faster than we have become emotional, and we cannot suffer feeling to exhibit itself without some explanation of its nature and causes being offered at the same time. If a man will unbosom to us his sorrow or his joy fully and intelligibly, we profess ourselves willing, provided he is not too wearisome and exacting, to lend him a patient ear and to endeavor to enter into his peculiar experiences; but, without this explanatory recital, the evidences of feeling are apt to appear unmeaning, if not actually offensive.

We may just point to another influence which still further complicates this question of emotional expression—namely, the growing demands made by social refinement on the expression of kindly interest in other people's concerns. While a man is judged to be inconsiderate if he is frequently intruding his personal feelings in social intercourse, rigid politeness requires us for the most part to lend an appreciative ear to the tale of woe, however dull it may happen to prove. This law calls into existence a very curious group of half-artificial expressions. The degree to which polite persons have nowadays to assume feeling may well alarm any one who cares much for the honesty of social intercourse. We all know probably the drawing-room smile of some of our lady friends. It is something quite unique, never appearing in other places and at other times, but presenting itself at the right moment with all the certainty of an astronomical phenomenon. So too we know persons whose voices undergo a most curious change when called on to converse with a stranger, especially one of the opposite sex. No doubt some slight part of the display may be set down to an unavoidable excitement, but the main features of it would seem to be deliberately assumed. In this way it

appears that, owing to the requirements of modern society, our volitions are called upon now to check feeling, now to force it into play. The studied graces of smile, dilating eye, and mellifluous voice, make up a perfectly new order of *quasi* expressions, which might perhaps in a highly-artificial state of society gradually supplant many of the older and familiar forms of emotional utterance. Whether the agencies which tend to sustain genuine emotional expression will prove to have more vitality than those which go to suppress it, and how far, supposing spontaneous utterances of emotion to grow out of date, artificial imitations of them will continue in fashion, are points which we do not attempt to determine. Enough has been said, perhaps, to show how curiously complex are the conditions of the problem.—*Saturday Review*.



## GENESIS, GEOLOGY, AND EVOLUTION.<sup>1</sup>

BY REV. GEORGE HENSLOW F. L. S., F. G. S.

THE theory, or rather doctrine, of the Evolution of Living Things has not yet received that uniform acceptance to which it is undoubtedly entitled. That it will in time become generally received may be reasonably presumed; but at present, with many theologians at least, the creative hypothesis obstinately holds its ground. Two causes may be assigned to account for this fact. First, there is the preconceived but erroneous idea of the method of creation derived from a misconception of the first chapter of Genesis. Secondly, there is the unfortunate but very general want of any scientific training, not only among the clergy, but in the public generally; and, as a result, there is that absence of a due power of appreciation of the arguments of the scientific man, which is so conspicuous in their style of reasoning

In order, therefore, that the proof of the wisdom and beneficence of the Almighty, as shown in the processes of evolution, may not be considered as based on unsound premises, it will be desirable to point out the untenableness of the present theological position, as well as the grounds upon which evolution is founded; and which will, let us hope, be soon recognized as incontrovertible by all who seek the truth in earnest. Until comparatively recent times the book of Genesis was supposed to reveal in its first chapter an explicit account of the origin of living things, namely, by direct creative fiat of the Almighty. All the known animals and plants being far fewer than at the present day, their differences were more pronounced than their resemblances. Each animal and plant was observed to bring forth

<sup>1</sup> From his recently-published work, "Evolution and Religion."



its offspring "after his kind," generation after generation, without any noticeable change. Any other animals than those now living on the globe were never conceived. Fossil shells were supposed to be either deep-sea creatures thrown up upon the beach, or, if found on land and upon hills, easily accounted for by the Deluge.

Every living thing was believed to have been created at once by the word of the Lord: and all within the space of six literal days.

When geology came to be studied with some philosophic spirit, it was soon discovered that many fossils were not of living species; that six days was incontestably too short a period to account for geological phenomena; that a flood, even if conceded to have been universal, was unable to solve many a problem of disturbance and stratification. Moreover, it was perceived that the earth's structure was separable into several strata; and that each stratum contained a group of fossils unknown either in the stratum above or below it; and upon this discovery was based the principle that disconnected strata might be recognized by the identity of their organic remains. In addition to these facts, the phenomena now known as *dislocation, contortion, upheaval, unconformability*, and others, frequently occurred, and apparently often during periods intervening between the deposition of strata.

These latter appearances, taken into consideration with the daily phenomena of volcanic action, induced the geologist to conceive, and the theologian to adopt, the theory of successive creations after cataclysmic and predetermined destructions of all existing life by the Almighty: while, to meet the now well-established truth of almost infinite ages having elapsed, the theologian adopted the interpretation of *ages* for the Hebrew word *yōm* or *day*. If, however, the first chapter of Genesis be read without any reference to or thought of geological discoveries, and the first three verses of the second chapter be carefully compared with the fourth commandment, it will not appear how any notion of an indefinite time can be given to the word "day" at all. The writer of Genesis seems to signify a day in the ordinary sense, and apparently without any conception of indefinite periods at all.

Geology ceased not to pursue her avocations steadily and unpromisingly.

The study of the rocks soon brought to light a large increase of the number of strata: so that at the present day there are *thirteen* "formations," embracing *thirty-nine* principal "strata," the strata themselves being often subdivided into minor ones. If, therefore, the miraculous recreations be true, they must have been very numerous. But with the discovery of additional strata a larger insight was obtained into the distribution in time of animal and vegetal life. It was then discovered that these "created groups" were not so rigidly defined as at first supposed, and consequently the rule established by geologists themselves can only be applied cautiously in attempting to

parallel distant strata—though some species appear to characterize strata respectively, yet many range up and down through other than those in which they attain their maximum development, or of which they may be especially characteristic.

Two difficulties thus arose: the increase of miraculous interferences *seemed to increase proportionately their improbability*; especially as there was no corroboration this time from the Word of God; while the fact of species ranging through several *strata* threw another stumbling-block in the way of the cataclysmic theory; for either they must have been recreated two or three times, or else lived through the supposed cataclysms considered as designed methods of destruction.

Another class of phenomena now appeared, to show a still greater difficulty in the way of belief in the creative hypothesis. Zoology, botany, as well as paleontology, gradually increased the number of living and extinct forms almost indefinitely; and in proportion as fresh discoveries were made, so it was found that numbers of forms took up positions, when classified, *intermediate* to other forms hitherto well distinct—"osculant" or intercalary forms as they are called. These often increased so much, that even genera well marked at first became blended together by transitional or intermediate forms.

Hence it has come to pass, from the result of this discovery, that so far from forms or types of organisms being easy and of a precise character, in accordance with the idea of each being well defined *after his kind*, systematic zoology and botany are the most difficult tasks a naturalist can undertake. Here, then, an overwhelming difficulty, only to be fully appreciated by a really scientific person, rises against the conception of each kind having been specially created as we see them now. Indeed, it may be added that the very idea of *kind* or *species* has been resolved into an abstract conception, finding in Nature generally no more than a relative existence.

Fresh difficulties were still in store, which must be overcome if the former theory of creation is to obtain any longer—horticulture, floriculture, agriculture, and the breeding of animals, have rapidly risen to become important and flourishing occupations. From their pursuit it was soon discovered that kinds reproducing their like *never did so absolutely*, but that offspring appeared always to differ from their parents in some trifling if not considerable degree. This property of Nature, to which also the human race is invariably subject, man has seized upon, and by judicious treatment can almost mould his cattle to whatever form he pleases, or stock his fields and gardens with roots of any form or with flowers of any shade of color required. After many years of successful propagation, generation after generation, we have now arrived at the result that animals and plants can be produced by careful breeding and selection, which, had they been wild, our earlier naturalists would have undoubtedly regarded as having been respec-

tively created at the beginning of the world! Here, then, we have a practical basis of argument to account for the many transitional forms which geology reveals in the past history of the world, as well as among the plants and animals living at the present day.

Yet another fact may be mentioned. Geographical botany and zoology began to be studied as travellers stocked our museums and herbaria with an ever-increasing number of beings brought from all parts of the world; and the (so to say) capricious distribution of identical forms in far-distant places—now explicable on the theory of migration and subsequent isolation—as well as the appearance of representative forms of allied though different kinds in certain districts, explicable *only* on the theory of descent with modification, has a strong *prima-facie* appearance against the theory of individual creations, even if geology did not furnish undoubted evidence of very frequent interchanges between land and sea having taken place. Without at present giving more reasons, the above will be sufficient to show cause why Science has found herself compelled to secede from the cramping toils of the creative hypothesis, and to take up that of the evolution of living things as better explaining *all* the foregoing phenomena. In proportion as the probability of the former was seen to decrease, so in the same degree does that of evolution increase. Hence, at the present day the argument in favor of development of species by natural laws may be stated in the following terms, viz.: “It is infinitely more probable that all living and extinct beings have been developed or evolved by natural laws of generation from preëxisting forms, than that they with all their innumerable races and varieties should owe their existences severally to creative fiat.”

But, even now, asks the theologian, Does not this theory controvert the Bible, for we are distinctly told that God created every thing after its kind?

In reply, it may be confidently shown that the theologian cannot be sure of the value of his interpretation of the first chapter of Genesis, at least so far as he attempts to draw scientific deductions from it. Thus it may be observed to him that the words “create” and “make” are used indifferently; that no definition is given to insure accuracy as to their right interpretation. It is not stated whether God created out of nothing or out of eternally or at least preëxisting matter. Moreover, in addition to the statement that God created or made all things, there is the oft-repeated assertion embodied in the word *fiat*, but apparently overlooked, that He enjoined the earth and the waters to bring forth living forms. What does this expression imply?

The use of the imperative mood can only signify *an agent other than the speaker*. If, therefore, it be maintained that the sentence (ver. 21) “God created every living thing that moveth” signifies He made them by his direct Almighty fiat, it may be equally maintained that the sentence “Let the waters bring forth abundantly every mov-

ing creature" implies secondary agents to carry out the will of the Lord. Such might be said to witness to natural law, which, after all, is but a synonym for the will of God.

The real basis of the controversy between dogmatic theology and this deduction of Science is simply this: The former has established a creed based upon erroneous impressions derived from Scripture, and, from having had power in former days to enforce its opinions, they were credulously received without hesitation as long as no one dared to or even could controvert them. It is the reluctance to surrender this power to Science as much as the idea of her offering any opposition to theology that urges at least one body so obstinately to resist her advances. Nearer home the opposition rests more on the latter ground; and it will not be until the representatives of our theology can see and confess their false impressions of the meaning of the first chapter of Genesis, that the doctrine of evolution can be hoped to make any great progress among them.

Let us briefly review their false positions. They first clung to the "six days of creation;" they found they were compelled to surrender the idea, and immediately adopted the interpretation of *yôm* signifying an indefinite period. Again, notice their readiness in adopting the theory of cataclysms and recreations, a second time to the detriment of Genesis, which furnishes no warrant for the idea; for even if six days be presumed to represent six cataclysms, geology furnishes no corresponding evidence. It was a pure fiction altogether. And even now they steadily oppose the doctrine of evolution. But surely as each stronghold of theology has been quietly taken by Science—not so much by offensive attack as by undermining and leaving the edifice to crumble of itself—the tardy and ungracious capitulations hitherto offered only insure the ultimate surrender a matter of patient expectation. *A time will shortly come* when the creative theory must succumb altogether and the doctrine (not the theory) of evolution will be as much recognized as a fundamental truth of science and theology as the revolution of the earth itself.



## GROWTH AND DECAY OF MIND.

"And so from hour to hour we ripe and ripe,  
And then from hour to hour we rot and rot,  
And thereby hangs a tale."—*As You Like It*.

**F**EW subjects of scientific investigation are more interesting than the inquiry into the various circumstances on which mental power depends. By mental power I do not mean simply mental capacity, or the potential quality of the mind, but the actual power which is the resultant, so to speak, of mental capacity and mental

training. The growth and development of mental power in the individual, and the process by which, after attaining a maximum of power, the mind gradually becomes less active, until in the course of time it undergoes at least a partial decay, form the special subjects of which I propose now to treat; but, in order to form clear ideas on these subjects, it will be necessary to consider several associated matters. In particular, it will be desirable to trace the analogy which exists between bodily and mental power, not only as respects development and decay, but with regard to the physical processes involved in their exercise.

It is now a well-established physiological fact that mental action is a distinctly physical process, depending primarily on a chemical reaction between the blood and the brain, precisely as muscular action depends primarily on a chemical reaction between the blood and the muscular tissues. Without the free circulation of blood in the brain, there can be neither thought nor sensation, neither emotions nor ideas. It necessarily follows that thought, the only form of brain-action which we have here to consider, is a process not merely depending upon, but in its turn affecting, the physical condition of the brain, precisely as muscular exertion of any given kind depends on the quality of the muscles employed and affects the condition of those muscles, not at the moment only, but thereafter, conducing to their growth and development if wisely adjusted to their power, or causing waste and decay if excessive and too long continued. It is important to notice that this is not a mere analogy. The relation between thought and the condition of the brain is a reality. So far as this statement affects our ideas about actually existent mental power, it is of little importance; for it is not more useful to announce that a man with a good brain will possess good mental powers than to say that a muscular man will be capable of considerable exertion. But as it is of extreme importance to know of the relation which exists between muscular exercise and the growth or development of bodily strength, so it is highly important for us to remember that the development of mental power depends largely on the exercise of the mind. There is a "training" for the brain as well as for the body—a real physical training—depending, like bodily training, on rules as to nourishment, method of action, quantity of exercise, etc.

When we thus view the matter, we at once recognize the significance of relations formerly regarded as mere analogies between mental and bodily power. Instead of saying that, as the body fails of its fair growth and development if overtaxed in early youth, so the mind suffers by the attempt to force it into precocious activity, we should now say that the mind suffers in this case in the same actual manner—that is, by the physical deterioration of the material in and through which it acts. Again, the old adage, "*mens sana in corpore sano*," only needs to be changed into "*cerebrum sanum in corpore sano*," to

express an actual physical reality. The processes by which the brain and the body are nourished, as well as those which produce gradual exhaustion when either is employed for a long time or on arduous work, not only correspond with each other, but are in fact identical in their nature; so that Jeremy Taylor anticipated a comparatively recent scientific discovery when he associated mental and bodily action in the well-known apothegm, "Every meal is a rescue from one death and lays up for another; and while we think a thought we die." This is true, as Wendell Holmes well remarks, "of the brain as of other organs: the brain can only live by dying. We must all be born again, atom by atom, from hour to hour, or perish all at once beyond repair."

And here it is desirable to explain distinctly that the relations between mind and matter which we are considering are not necessarily connected with any views respecting the questions which have been at issue between materialism and its opponents. We are dealing here with the instrument of thought, not with *that*, whatever it may be, which sets the instrument in motion and regulates its operation. So far, indeed, as there is any connection between physical researches into the nature of the brain or its employment in thought, and our ideas respecting the individuality of the thinker, the evidence seems not of a nature to alarm even the most cautious. Thus, when Mr. Huxley maintains that thought is "the expression of molecular changes in that matter of life which is the source of our other vital phenomena," we are still as far as ever from knowing where resides the moving cause to which these changes are due. We have found that the instrument of thought is moved by certain material connecting links before unrecognized; but to conclude that therefore thought is a purely material process, is no more necessarily just than it would be to conclude that the action of a steam-engine depends solely on the eccentric which causes the alternation of the steam-supply. Again, we need find nothing very venturesome in Prof. Houghton's idea, that "our successors may even dare to speculate on the changes that converted a crust of bread, or a bottle of wine, in the brain of Swift, Molière, or Shakespeare, into the conception of the gentle Glumdalclitch, the rascally Sganarelle, or the immortal Falstaff," seeing that it would still remain unexplained how such varying results may arise from the same material processes, or how the selfsame fuel may produce no recognizable mental results. The brain does not show in its constitution why such differences should exist. "The lout who lies stretched on the tavern-bench," says Wendell Holmes, "with just mental activity enough to keep his pipe from going out, is the unconscious tenant of a laboratory where such combinations are being constantly made as never Wöhler or Berthelot could put together; where such fabrics are woven, such colors dyed, such problems of mechanism solved, such a commerce carried on with the elements and forces of the outer uni-



verse, that the industries of all the factories and trading establishments in the world are mere indolence, and awkwardness, and unproductiveness, compared to the miraculous activities of which his lazy bulk is the unheeding centre." Yet the conscious thought of the lout remains as unlike as possible to the conscious thought of the philosopher; nor will crusts of bread or bottles of wine educe aught from the lout's brain that men will think worth remembering in future ages.

Moreover, we must remember that we have to deal with facts, let the interpretation of these facts be what it may. The relations between mental activity and material processes affecting the substance of the brain are matters of observation and experiment. We may estimate the importance of such research with direct reference to the brain as the instrument of thought, without inquiring by what processes that instrument is called into action. "The piano which the master touches," to quote yet again from the philosophic pages of Holmes's "Mechanism in Thought and Morals," "must be as thoroughly understood as the musical box or clock which goes of itself by a spring or weight. A slight congestion or softening of the brain shows the least materialistic of philosophers that he must recognize the strict dependence of mind upon its organ in the only condition of life with which we are experimentally acquainted; and, what all recognize as soon as disease forces it upon their attention, all thinkers should recognize without waiting for such an irresistible demonstration. They should see that the study of the organ of thought, microscopically, chemically, experimentally, in the lower animals, in individuals and races, in health and in disease, in every aspect of external observation, as well as by internal consciousness, is just as necessary as if the mind were known to be nothing more than a function of the brain, in the same way as digestion is of the stomach."

In considering the growth of the mind, however, in these pages, it appears to me sufficient to call attention to the physical aspect of the subject, without entering into an account of what is known about the physical structure of the brain and the manner in which that structure is modified with advancing years. Moreover, I do not think it desirable, in the limited space available for such an essay as the present, to discuss the various forms of mental power; indeed, this is by no means essential where a general view of mental growth and decay is alone in question. Precisely as we can consider the development and decay of the bodily power without entering into a discussion of the various forms in which that power may be manifested, so we can discuss the growth of the mind without considering special forms of mental action.

Nevertheless, we cannot altogether avoid such considerations, simply because we must adopt some rule for determining what constitutes

mental power. Here, indeed, at the outset, a serious difficulty is encountered. Certain signs of mental decay are sufficiently obvious, but the signs which mark the progress of the mind to its maximum degree of power, as well as the earlier signs of gradually diminishing mental power, are far more difficult of recognition. This is manifest when we consider that they should be more obvious, one would suppose, to the person whose mind is in question, than to any other; whereas it is a known fact that men do not readily perceive (certainly are not ready to admit) any falling off in mental power, even when it has become very marked to others. "I, the Professor," says Wendell Holmes in the "Professor at the Breakfast-table," "am very much like other men. I shall not find out when I have used up my affinities. What a blessed thing it is that Nature, when she invented, manufactured, and patented her authors, contrived to make critics out of the chips that were left! Painful as the task is, they never fail to warn the author, in the most impressive manner, of the probabilities of failure in what he has undertaken. Sad as the necessity is to their delicate sensibilities, they never hesitate to advertise him of the decline of his powers, and to press upon him the propriety of retiring before he sinks into imbecility." Notwithstanding the irony, which is just enough so far as it relates to ordinary criticism, there can be no question that, when an author's powers are failing, his readers, and especially those who have been his most faithful followers, so to speak, devouring each of his works as it issues from his pen, begin to recognize the decrease of his powers before he is himself conscious that he is losing strength. The case of Scott may be cited as a sufficient illustration, its importance in this respect being derived from the fact that he had long been warmly admired and enthusiastically appreciated by those who at once recognized signs of deterioration in "Count Robert of Paris," and "Castle Dangerous."

Yet judgment is most difficult in such matters. We can readily see why no man should be skilled to detect the signs of change in his own mind, since the self-watching of the growth and decay of mind is an experiment which can be conducted but once, and which is completed only when the mind no longer has the power of grasping all the observed facts and forming a sound opinion upon them. But it is even more natural that those who follow the career of some great mind should often be misled in their judgment as to its varying power. For, it must be remembered that the conditions under which such minds are exercised nearly always vary greatly as time proceeds. This circumstance affects chiefly the correctness of ideas formed as to the decay of mental powers, but it has its bearing also on the supposed increase of these powers. For instance, the earlier works of a young author, diffident perhaps of his strength, or not quite conscious where his chief strength resides, will often be characterized by a weakness which is in no true sense indicative of want of mental power. A work by the

same author when he has made for himself a name, when he knows something of the feeling of the public as to his powers, and when also he has learned to distinguish the qualities he possesses—to see where he is strong and where weak—will have an air of strength and firmness not due, or only partially due, to any real growth of his mental powers. But, as I have said, and as experience has repeatedly shown, it is in opinions formed as to the diminution of mental power that the world is most apt to be deceived. How commonly the remark is heard that So-and-so has written himself out, or Such-a-one is not the man he was, when in reality, as those know who are intimate with the author so summarily dismissed, the deterioration, justly enough noted, is due to circumstances in no way connected with mental capacity! The author who has succeeded in establishing a reputation may not have (nay, very commonly has not) the same reason for exerting his powers to the full, as he had when he was making his reputation. He may have less leisure, more company, new sources of distraction, and so on. The earlier work, his *chef-d'œuvre*, let us say, may have been produced at one great effort, no other subject being allowed to occupy his attention until the masterpiece had been completed—the later and inferior work, hastily accepted as evidence that the author's mind no longer preserves its wonted powers, may have been written hurriedly and piecemeal, and subjected to no jealous revision before passing through the press.

Here I have taken literary work as affording typical instances. But similar misapprehensions are common in other departments of mental work. For example, it is related that Newton, long before he was an old man, said of himself that he could no longer follow the reasoning of his own "Principia," and this has commonly been accepted as evidence that his mind had lost power. The conclusion is an altogether unsafe one, as every mathematician knows. It would have been a truly wonderful circumstance if Newton had been able, even only ten or twelve years after his *magnum opus* was completed, to follow its reasoning with satisfaction to his own mind—that is, with the feeling that he still had that grasp of the subject which he had possessed when, after long concentration of his thoughts upon it, he was engaged in the task of exhibiting a summary of his reasoning (for the "Principia" is scarcely more).

I can give more than one instance, in my own experience, of this seeming loss of mastery over a mathematical subject, while in reality the mind has certainly not deteriorated in its power of dealing with subjects of that particular kind. I will content myself with one. It happened that in 1869 I had occasion to examine a mathematical subject of no very great difficulty, but involving many associated relations, and requiring therefore a considerable amount of close attention. At that time I had made myself master, I think I may say without conceit, of that particular subject in all its details. Recently, I had

occasion to resume the study of a part of the subject, in order to reply to some questions which had been asked me. Greatly to my annoyance, I found that I had apparently lost my grasp of it. The relations involved seemed more complex than they had before appeared to me; and I should there and then have dismissed the subject (not having leisure for mere mental experiments) with the feeling that my strength for mathematical inquiries had diminished. But the subject chanced to be one that I could not dismiss, for, though the questions directed to me might have been left unanswered, the time had come which I had assigned to myself (under certain eventualities then realized) for a complete restatement of my views, enforced and reiterated in every possible way, until a certain course depending upon them should have been adopted, or else the discussion of the matter rendered useless by lapse of time. I soon found, after resuming my study of the subject, that it was far more completely within my grasp than before—in fact, on reacquiring my knowledge of its details, the problems involved appeared to me as mere mathematical child's-play.

The great difficulty in judging of the growth and development of the mind consists in the want of any reliable measure of mental strength—any mental dynamometer, so to speak. Our competitive examinations are attempts in this direction, but very imperfect ones, as experience has long since shown. Neither acquired knowledge, nor the power of acquiring knowledge, is any true measure of mental strength. The power of solving mathematical problems is not necessarily indicative even of mathematical power, far less of general mental power. The ordinary tests of classical knowledge, again, have little real relation to mental strength. It may be urged that our most eminent men have, for the most part, been distinguished, at school or university, by either mathematical or classical knowledge, or both. This is doubtless true; but so it would be the case that they would have distinguished themselves above their fellows at public school or university if the heads of these establishments had in their wisdom set Chinese puzzling as the primary test of merit. The powerful mind will show its superiority (in general) in any task that may be assigned it; and, if the test of distinction is to be the skillful construction of Greek and Latin verse, or readiness in treating mathematical problems, a youth of good powers, unless he be wanting in ambition, will acquire the necessary qualifications even though he has no special taste for classical or mathematical learning, and is even perfectly assured that in after-life he will never pen a sapphic or set down an equation of motion.

In passing, I may note that nearly all our attempted measurements of mind depend too much on tests of memory. It is not recognized sufficiently that the part which memory plays in the workings of a powerful mind is subordinate. A good memory is a very useful servant; nothing more. In the really difficult mental processes, memory—

at least what is commonly understood by the term—plays a very unimportant part. Of course a weak memory is an almost fatal obstacle to effective thought; but I am not comparing the worth of a good memory and a bad one, but of an average memory and one exceptionally powerful. I conceive that quite a large proportion of the most profound thinkers are satisfied to exert their memory very moderately. It is, in fact, a distraction from close thought to exert the memory overmuch; and a man engaged in the study of an abstruse subject will commonly rather turn to his book-shelves for the information he requires than tax his memory to supply it. The case resembles somewhat that of the mathematician who from time to time, as his work proceeds, requires this or that calculation to be effected. He will not leave the more engrossing questions that he has in his thoughts, to go through processes of arithmetic, but will adopt any ready resource which leaves him free to follow without check the train of his reasoning.

It would be perhaps difficult to devise any means of readily measuring mental power in examination or otherwise. The memory test is assuredly unsafe; but it would not be easy to suggest a really reliable one. I may remark that only those experienced in the matter understand how much depends on memory in our competitive examinations. Many questions in the examination-papers apparently require the exercise of judgment rather than memory; but those who know the text-books on which the questions are based are aware that the judgment to be written down in answer is not to be formed but to be quoted. So with mathematical problems which appear to require original conceptions for their solution: in nine cases out of ten such problems are either to be found fully solved in mathematical works, or others so nearly resembling them are dealt with that no skill is required for their solution.

I must confess that I am somewhat surprised to find Wendell Holmes, whose opinions on such matters are usually altogether reliable, recommending a test of mental power depending on a quality of memory even inferior to that usually in question in competitive examinations. "The duration of associated impressions on the memory differs vastly," he says, "as we all know, in different individuals. But in uttering distinctly a series of unconnected numbers or letters before a succession of careful listeners, I have been surprised to find how generally they break down, in trying to repeat them, between seven and ten figures or letters; though here and there an individual may be depended on for a larger number. Pepys mentions a person who could repeat sixty unconnected words, forward or backward, and perform other wonderful feats of memory; but this was a prodigy.<sup>1</sup>

<sup>1</sup> "This is nothing to the story told by Seneca of himself, and still more of a friend of his, one Portius *Latro* (*Mendax* it might be suggested), or to that other relation of Muretus, about a certain young Corsican." The note is Holmes's; but there are authen-

I suspect we have in this and similar trials a very simple mental dynamometer which may find its place in education." It appears to me, on the contrary, that tests of the kind should be as little used as may be. Memory will always have an unfair predominance in competitive examinations; but tests which are purely mnemonic, the judgment being in no way whatever called upon, ought not to be introduced, and should be discarded as soon as possible where already in use.<sup>1</sup>

It is worthy of notice that the growth of the mind is often accompanied by an apparent loss of power in particular respects; and this fact is exceedingly important, especially to all who desire to estimate the condition of their own mind. The mental phenomenon called (not very correctly) absence of mind is often regarded by the person experiencing it, and still more by those who observe it in him, as a proof of failing powers. But it often, if not generally, accompanies the increase of mental power. Newton displayed absence of mind much more frequently and to a much more marked degree when his powers were at their highest than in his youth, and not only did instances become much less frequent when he was at an advanced age, but the opposite quality, sensitiveness to small annoyances, began then to be displayed. Even an apparent impairment of the memory is not necessarily indicative of failing mental powers, since it is often the result of an increased concentration of the attention on subjects specially calling for the exercise of the highest forms of mental power—as analysis, comparison, generalization, and judgment. I have already noted that profound thinkers often refrain from exercising the memory, simply to avoid the distraction of their thoughts from the main subject of their study. But this statement may be extended into the general remark that the most profound students, whether of physical science, mathematics, history, politics, or, in fine, of any difficult subject of research, are apt to give the memory less exercise than shallower thinkers. Of course, the memory is exerted to a considerable degree, even in the mere marshaling of thoughts before theories can be formed or weighed. But the greater part of the mental action

ticated instances fully as remarkable as those here referred to. For instance, there is a case of an American Indian who could repeat twenty or thirty lines of Homer which had been read once to him, though he knew nothing of the Greek language. The power of repeating *backward* a long passage after it has been but once read is somewhat similar to that of repeating unconnected numbers, letters, or words. This power has been possessed to a remarkable degree by persons in no way distinguished by general ability

<sup>1</sup> It may perhaps occur to the reader that I who write may object to mnemonic tests, because they would act unfavorably if they were applied to my own mental qualities. The reverse is, however, the case. I can recall competitive examinations in which I had an undue advantage over others because my memory chances to be very retentive in one particular respect: In its general nature my memory is about equal, I imagine, to the average, perhaps it is better than the average for facts, and rather below the average for what is commonly called learning "by heart:" but it is singularly retentive for the subject-matter of passages *read overnight*.



devoted to the formation or discussion of theories is only indirectly dependent upon the exercise of memory.

Subject to the considerations suggested above, we may fairly form our opinion as to the general laws of the development of mind, by examining the lives of distinguished men and taking the achievement of their best work, that by which they have made their mark in the world's history, as indicative of the epoch when the mind had attained its greatest development. Dr. Beard, of New York, has recently collected some statistical results, which throw light on the subject of mental growth, though we must note that a variety of collateral circumstances have to be taken into account before any sound opinion can be formed as to the justice of Dr. Beard's conclusions. He states that "from an analysis of the lives of a thousand representative men in all the great branches of human effort, he had made the discovery that the golden decade was between thirty and forty, the silver between forty and fifty, the brazen between twenty and thirty, the iron between fifty and sixty. The superiority of youth and middle life over old age in original work appears all the greater, when we consider the fact that nearly all the positions of honor and profit and prestige—professorships and public stations—are in the hands of the old. Reputation, like money and position, is mainly confined to the old. Men are not widely known until long after they have done the work that gives them their fame. Portraits of great men are a delusion; statues are lies. They are taken when men have become famous, which, on the average, is at least twenty-five years after they did the work which gave them their fame. Original work requires enthusiasm. If all the original work done by men under forty-five were annihilated, the world would be reduced to barbarism. Men are at their best at that time when enthusiasm and experience are most evenly balanced; this period on the average is from thirty-eight to forty. After this period the law is that experience increases but enthusiasm declines. In the life of almost every old man there comes a point, sooner or later, when experience ceases to have any educating power."

There is much that is true, but not a little that is, to say the least, doubtful, in the above remarks. The children of a man's mind, like those of his body, are commonly born while he is in the prime of life. But it must not be overlooked that it is precisely because of the original work done in earlier life that a man as he grows older is commonly prevented from accomplishing any great amount of original work. Nearly the whole of his time is necessarily occupied in maturing the work originated earlier. And again, the circumstance that (usually) a man finds that the work of his earlier years remains incomplete and unsatisfactory, unless the labors of many sequent years are devoted to it, acts as a check upon original investigation. This remark has no bearing, or but slight bearing, on certain forms of literary work; but in nearly every other department of human effort men

advanced in years find themselves indisposed to undertake original research, not from any want of power, but because they recognize the fact that sufficient time does not remain for them to bring such work to a satisfactory issue. They feel that they would have to leave to others the rearing of their mental offspring.

It cannot be questioned, however, that with old age there comes a real physical incapacity for original work, while the power of maturing past work remains comparatively but little impaired. Dr. Carpenter has shown how this may partly be explained by the physical changes which lead in old age to the weakening of the memory; or perhaps we should rather say that in the following passage his remarks respecting loss of memory serve to illustrate the loss of brain-power generally, and especially of the power of forming new ideas, in old age. "The impairment of the memory in old age," he says, "commonly shows itself in regard to new impressions; those of the earlier period of life not only remaining in full distinctness, but even it would seem increasing in vividness, from the fact that the eye is not distracted from attending to them by the continued influx of impressions produced by passing events. The extraordinary persistence of early impressions, when the mind seems almost to have ceased to register new ones, is in remarkable accordance with a law of nutrition I have formerly referred to. It is when the brain is growing that the direction of its structure can be most strongly and persistently" (query, lastingly) "given to it. Thus the habits of thought come to be formed, and those nerve-tracks laid down which (as the physiologist believes) constitute the mechanism of association, by the time that the brain has reached its maturity; and the nutrition of the organ continues to keep up the same mechanism in accordance with the demands upon its activity, so long as it is being called into use. Further, during the entire period of vigorous manhood, the brain, like the muscles, may be taking on some additional growth, either as a whole or in special parts; new tissue being developed and kept up by the nutritive process, in accordance with the modes of action to which the organ is trained. And in this manner a store of 'impressions' or 'traces' is accumulated, which may be brought within the 'sphere of consciousness' whenever the right suggesting strings are touched. But, as the nutritive activity diminishes, the 'waste' becomes more rapid than the renovation; and it would seem that, while (to use a commercial analogy) the 'old-established houses' keep their ground, those later firms, whose basis is less secure, are the first to crumble away—the nutritive activity which yet suffices to maintain the original structure not being capable of keeping the subsequent additions to it in working order. This earlier degeneration of later-formed structures is a general fact perfectly familiar to the physiologist."

One of the most remarkable features of mental development, characteristic, according to circumstances, of mental growth and of mental

decay, is the change of taste for mental food of various kinds. Every one must be conscious of the fact that books, and the subjects of thought, lose the interest they once had, making way for others of a different nature. The favorite author, whose words we read and re-read with continually fresh enjoyment in youth, appears dull and uninteresting as the mind grows, and becomes unendurable in advanced years. And this is not merely the effect of familiarity. I knew one who was never tired of reading the works of a famous modern novelist until the age of twenty-five or thereabouts, when it chanced that he was placed in circumstances which caused novel-reading to be an unfrequent occupation, and in point of fact certain works of this author were not opened by him for ten or twelve years. He supposed, when at the end of that time he took up one of these works, that he should find even more than the pleasure he formerly had in reading it, since the story would now have something of novelty for him, and he had once thoroughly enjoyed reading it even when he almost knew the work by heart. But he no longer found the work in the least interesting; the humor seemed forced, the pathos affected, the eloquence false; in short, he had lost his taste for it. In the mean time the works of another equally famous humorist had acquired a new value in his estimation.<sup>1</sup> They had formerly seemed rather heavy reading; now, every sentence gave enjoyment. They appeared now as books not to be merely tasted or swallowed, as Bacon hath it, but "to be chewed and digested." The change here described indicated (in accordance at least with the accepted estimates of the novelist and humorist in question) an increase of mental power. But a distaste for particular writings may imply the decay of mental power. And also, more generally, a tendency to disparagement is a very common indication of advancing mental age. "The old brain," says Wendell Holmes, "thinks the world grows worse, as the old retina thinks the eyes of needles and the fractions in the printed sales of stocks grow smaller."

Another singular effect of advancing years is shown by the tendency to repetition. It is worthy of notice that this peculiar mental phenomenon has been clearly associated with physical deterioration of the substance of the brain, because it may be brought about by a blow or by disease. Wendell Holmes, speaking of this peculiarity, remarks, "I have known an aged person repeat the same question five,

<sup>1</sup> Probably the best means of testing the development of one's own mind consists in comparing the estimate formed, at different times, of the value of some standard work. Of course different classes of writing should be employed to test different faculties of the mind. A good general test may be found in Shakespeare's plays, and perhaps still better in some of Shakespeare's sonnets. As the mind grows, its power of appreciating Shakespeare increases; and the great advantage of this particular test is, that the mind cannot overgrow it. It is like the standard by which the sergeant measures recruits, which will measure men of all heights, not failing even when giants are brought to be measured by it.

six, or seven times, during the same brief visit. Everybody knows the archbishop's flavor of apoplexy in the memory as in the other mental powers. I was once asked to see a woman who had just been injured in the street. On coming to herself, 'Where am I? What has happened?' she asked. 'Knocked down by a horse, ma'am; stunned a little; that is all.' A pause, 'while one, with moderate haste, might count a hundred;' and then again, 'Where am I? What has happened?' 'Knocked down by a horse, ma'am; stunned a little; that is all.'" (Mr. Holmes appears to have sympathized with the patient's mental condition.) "Another pause, and the same question again; and so on during the whole time I was by her. The same tendency to repeat a question indefinitely has been observed in returning members of those worshipping assemblies whose favorite hymn is 'We won't go home till morning.' Is memory then," he proceeds, "a material record? Is the brain, like the rock of the Sinaitic Valley, written all over with inscriptions left by the long caravans of thought, as they have passed year after year through its mysterious recesses? When we see a distant railway-train sliding by us in the same line, day after day, we infer the existence of a track which guides it. So, when some dear old friend begins that story we remember so well—switching off at the accustomed point of digression; coming to a dead stop at the puzzling question of chronology; off the track on the matter of its being first or second cousin of somebody's aunt; set on it again by the patient, listening wife, who knows it all as she knows her well-worn wedding-ring—how can we doubt that there is a track laid down for the story in some permanent disposition of the thinking-marrow?"

We seem to recognize here a process of change in the brain corresponding to that which takes place in the body with advancing years—the induration of its substance, so that it loses flexibility, and thus, while readily accomplishing accustomed work, is not readily adapted for new work. Our old proverb, "You can't teach an old dog new tricks," indicates, coarsely enough, but justly, the peculiarity, as well mental as bodily, to which I refer. There is not a loss of power, but a loss of elasticity. We see aged men working well in the routine work to which they have been accustomed, but failing where there is occasion for change either of method or of opinion. Again, one recognizes this peculiarity in the scientific worker, whence perhaps we may regard it as a fortunate circumstance that the tendency of the aged mind accords with its faculties, so that old men do not readily undertake new work. Perhaps no more remarkable instance could be cited of the combination I refer to—the possession of power on the one hand, and the want of elasticity on the other—than the remarkable papers on the universe, written by Sir W. Herschel, in the years 1817 and 1818, that is, in his seventy-ninth and eightieth years. We find the veteran astronomer proceeding in the path which, more than forty years before,

he had marked out for himself; but the very steadiness and strength of purpose with which he pursues it indicate the degree to which his mind had lost its wonted elasticity. In 1784 and 1785 he was traversing a portion of the same road. But then he was in the prime of his powers, and accordingly we recognize a versatility which enabled him to test and reject the methods of research which presented themselves to his mind. It was in those years that he invented his famous method of star-gauging, which our text-books of astronomy preposterously adopt as if it were an established and recognized method of scientific research. But Herschel himself, after trying it, and satisfying himself that it was unsound in principle, abandoned it altogether. In 1817 he adopted a method of research equally requiring to be tested, and, in my conviction, equally incapable of standing the test; but he now worked upon the plan he had devised, without subjecting it to any test. Nay, results which only a few years before he would certainly have rejected—for he did then actually reject results which were open to the same objection—passed muster in 1817 and 1818, and are recorded in his papers of those dates without comment. We may recognize another illustration of the loss of elasticity with advancing years, in the obstinacy, one may even say the perversity, with which Sir Isaac Newton, in the latter years of his life, adhered to opinions on certain points where, as has since been shown, he was unquestionably wrong, and where, had he possessed his former mental versatility, he must have perceived as much. Compare this with his conduct in earlier years, when for nineteen years he freely abandoned his theory of gravitation—though he had fully recognized its surpassing importance—simply because certain minute details were not satisfactorily accounted for. Many other instances might be cited, were it worth while, to show how the mind commonly changes when approaching an advanced age, in a manner corresponding to that bodily change—that stiffness and want of elasticity, without any marked loss of power—which comes on with advancing years. That old age does not necessarily involve any loss of power for routine work, has been clearly shown in the lives of many eminent men of our own era. The present Astronomer Royal for England affords a remarkable illustration of the fact, as also of the associated fact that new work is not easily achieved, nor an old mistake readily admitted or corrected at an advanced age.

It is well pointed out by Dr. Beard, in the lecture to which I have already referred, that “we must not expect to find at one age the mental qualifications due to another age—we must not look for experience and caution in youth, or for suppleness and versatility in age. We ought also to apportion to the various ages of a man the kind of work most suitable to them. Positions which require mainly enthusiasm and original work should be filled by the young and middle-aged; positions that require mainly experience and routine work, should be

filled by those in mature and advanced life, or (as in clerkships) by the young who have not yet reached the golden decade. The enormous stupidity, and backwardness, and red-tapeism, of all departments of governments everywhere, are partly due to the fact that they are too much controlled by age. The conservatism and inferiority of colleges are similarly explained. Some of those who control the policy of colleges—presidents and trustees—should be young and middle-aged. Journalism, on the other hand, has suffered from relative excess of youth and enthusiasm.”

Before passing from the lecture of Dr. Beard, I shall venture to quote the remarks which he makes on the evidence sometimes afforded of approaching mental decay by a decline in moral sensitiveness. “Moral decline in old age,” he says, “means—‘Take care; for the brain is giving way.’ It is very frequently accompanied or preceded by sleeplessness. Decline of the moral faculties, like the decline of other functions, may be relieved, retarded, and sometimes cured by proper medical treatment, and especially by hygiene. In youth, middle age, and even in advanced age, one may suffer for years from disorders of the nervous system that cause derangement of some one or many of the moral faculties, and perfectly recover. The symptoms should be taken early, and treated like any other physical disease. Our best asylums are now acting upon this principle, and with good success. Medical treatment is almost powerless without hygiene. Study the divine art of taking it easy. Men often die as trees die, slowly, and at the top first. As the moral and reasoning faculties are the highest, most complex, and most delicate development of human nature, they are the first to show signs of cerebral disease. When they begin to decay in advanced life, we are generally safe in predicting that, if these signs are neglected, other functions will sooner or later be impaired. When conscience is gone, the constitution is threatened. Everybody has observed that greediness, ill-temper, despondency, are often the first and only symptoms that disease is coming upon us. The moral nature is a delicate barometer, that foretells long beforehand the coming storm in the system. Moral decline, as a symptom of cerebral disease, is, to say the least, as reliable as are many of the symptoms by which physicians are accustomed to make a diagnosis of various diseases of the bodily organs. When moral is associated with mental decline in advanced life, it is almost safe to make a diagnosis of cerebral disease. . . . Let nothing deprive us of our sleep. Early to bed and late to rise make the modern toiler healthy and wise. The problem for the future is to work hard, and at the same time to take it easy. The more we have to do, the more we should sleep. Let it never be forgotten that death in the aged is more frequently a slow process than an event; a man may begin to die ten or fifteen years before he is buried.”

When mental decay is nearing the final stage, there is a tendency



to revert to the thoughts and impressions of former years, which is probably dependent on the processes by which the substance of the brain is undergoing decay. The more recent formations are the first, as we have seen, to crumble away, and the process not only brings to the surface, if we may so speak, the earlier formations—that is, the material records of earlier mental processes—but would appear to bring those parts of the cerebrum into renewed activity. Thus, as death draws near, men “babble of green fields,” as has been beautifully said, though not by Shakespeare, of old Jack Falstaff. Or less pleasant associations may be aroused, as we see in Mrs. Grandmother Smallweed, when “with such infantine graces as a total want of observation, memory, understanding, and intellect, and an eternal disposition to fall asleep over the fire and into it,” she “whiled away the rosy hours” with continual allusions to money.

The recollections aroused at the moment of death are sometimes singularly affecting. None can read without emotion the last scenes of the life of Colonel Newcome. I say the last scenes, not the last scene only, though that is the most beautiful of all. Every one knows those last pages by heart, yet I cannot forbear quoting a few sentences from them. “‘Father!’ cries Clive, ‘do you remember Orme’s “History of India?”’ ‘Orme’s History, of course I do; I could repeat whole pages of it when I was a boy,’ says the old man, and began forthwith: “‘The two battalions advanced against each other cannonading, until the French, coming to a hollow way, imagined the English would not venture to pass it. But Major Lawrence ordered the sepoy and artillery—the sepoy and artillery to halt, and defend the convoy against the Morattoes.’ Morattoes, Orme calls them. Ho! ho! I could repeat whole pages, sir.’” Later, “Thomas Newcome began to wander more and more. He talked louder; he gave the word of command, and spoke Hindoostanee, as if to his men. Then he spoke words in French rapidly, seizing a hand which was near him, and crying, ‘Toujours, toujours.’ But it was Ethel’s hand which he took. . . . Some time afterward, Ethel came in with a scared face to our pale group. ‘He is calling for you again, dear lady,’ she said, going up to Madame de Florac, who was still kneeling. ‘And just now he said he wanted Pendennis to take care of his boy. He will not know you.’ She hid her tears as she spoke. She went into the room, where Clive was at the bed’s foot; the old man within it talked on rapidly for awhile; then again he would sigh and be still: once more I heard him say hurriedly, ‘Take care of him when I’m in India,’ and then with a heart-rending voice he called out, ‘Léonore, Léonore!’ She was kneeling at his side now. The patient’s voice sank into faint murmurs; only a moan now and then announced that he was not asleep. At the usual evening hour the chapel-bell began to toll, and Thomas Newcome’s hands outside the bed feebly beat time. And, just as the last bell struck, a peculiar; sweet smile shone over his face, and he

lifted up his head a little, and quickly said, 'Adsum!' and fell back. It was the word we used at school when names were called, and lo, he, whose heart was as that of a little child, had answered to his name, and stood in the presence of The Master."

Sadder than death is it, however, when the brain perishes before the body. "How often, alas, we see," says Wendell Holmes, "the mighty satirist tamed into oblivious imbecility; the great scholar wandering without sense of time or place, among his alcoves, taking his books one by one from the shelves and fondly patting them: a child once more among his toys, but a child whose to-morrows come hungry, and not full-handed—come as birds of prey in the place of the sweet singers of morning. We must all become as little children if we live long enough; but how blank an existence the wrinkled infant must carry into the kingdom of heaven, if the Power that gave him memory does not repeat the miracle by restoring it!"—*Cornhill Magazine*.



### AN EPISODE ON RATS.

THE Norway rat, of which we wish to say a few words, is the *Lemming*, a species of the mouse-tribe, somewhat smaller than the Guinea-pig, to which in form it bears a considerable resemblance, only the head and body are flatter. Its length is about six inches, of which the short stump of a tail forms half an inch. It is black in color, mottled with tawny spots, which vary in their disposition in different individuals, and the belly is white, with a slight tinge of yellow. The fore-legs are short and strong, and the hind-legs are nearly one-half longer than the former, enabling it to run with considerable speed. The feet are armed with strong hooked claws, five in number, enabling it to burrow in the earth, and among the frozen snows of its native region. Its cheeks are blanched, and it sports a pair of long light whiskers, and its eyes, though small, are beautifully black and piercing. The lip is divided, and the ears are small and sharply pointed. As its home borders on the region of eternal snow, in the valleys of the Kolen Mountains, which separate Sweden from Nordland, its hair is both thick and soft, and becomes almost white during the long and cheerless winter of these inhospitable regions. The skin is much thinner than in any of its congeners. When enraged it gives utterance to a sharp yelp, similar to that of a month-old terrier-whelp.

It is a lively little fellow, when met with in its native haunts, during the short summer—now sitting on its haunches nibbling at a piece of lichen, or the catkins of the birch, which it conveys to its mouth with its fore-paws, after the manner of the squirrel, or engaging in a romp with its fellows, popping in and out of its burrow in the earth

where it sleeps and rears its young, of which the female has two or three litters annually, numbering from five to seven in each. It is a most audacious little fellow, and fears neither man nor beast, refusing to give way save on the compulsion of superior force. Travelers speak of having seen them frisking about in hundreds in their native forests, when they dispute the path even with man. From the vantage-ground of the mounds of earth at the entrance to their burrows, they sit on their beam-ends and scan the intruders with comical gravity. If the traveler has a dog with him, unhappily ignorant of the ways of this cool and impudent *varmint*, he will likely advance with the easy nonchalance of his tribe to smell the odd little animal—which betrays no fear at his approach—to be rewarded by a sharp and trenchant bite on the nose; a reception so sudden and unexpected that it is ten chances to one against his prosecuting his investigations further, for a dog is too well bred to attack any strange living object which awaits his approach.

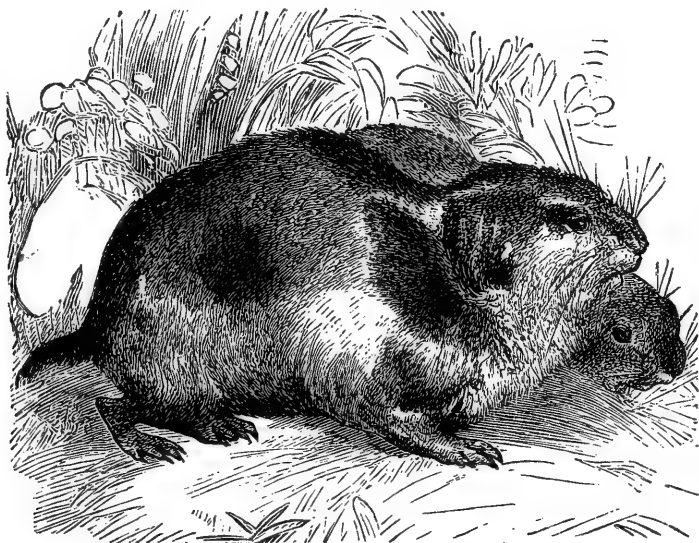

LEMMING, OR NORWAY RAT.

Unlike many of its congeners, the lemming does not provide a sufficient store of food to last it through the long winter, when the earth is covered with snow, and, as it does not hibernate, it is driven to many a hard shift in its struggle for a subsistence. It devours the bark of trees and small twigs, and drives tunnels through the snow, along the surface of the ground, eating every shred of vegetation it meets with. These food-burrows are all connected with a main burrow, leading to its home in the earth, which is ventilated by a hole driven obliquely through the snow to the surface. These air-shafts guide the arctic fox and the ermine to their whereabouts, and they devour many of them, while kites and other predaceous birds are ever on the watch to pick them up when they emerge upon the surface. The natives of these regions kill and eat them during summer, when they are in good condition; and a traveled friend of ours, who has

partaken of its flesh, speaks of it as a most valuable addition to their scanty *cuisine*. When captured young, it is easily tamed and becomes an interesting pet. We saw one once in the possession of a Montrose skipper, which allowed itself to be handled and fed out of the hand, but it had an awkward habit of fixing its incisors into the fingers of an incautious admirer on the smallest provocation. During summer they swarm with vermin to such an extent that, although when examined singly they can scarcely be discerned by the naked eye, they change the color of the animal to a dull red.

The lemming multiplies so rapidly that in the course of ten or twelve seasons food becomes scarce, and, on the approach of some winter when the food-question has become one of life or death, the overstocked market is relieved by an expedient unparalleled in its nature among four-footed animals. This singular little creature is so local in its habits, that, unless under the circumstances we are about to narrate, it never leaves the mountain-regions to establish itself on the plains, where food is more abundant.

The inhuman suggestion of a modern writer that our paupers should be packed into rotten ships, which should be sent out to sea and scuttled, is something like the method adopted by the lemmings themselves to avert the famine which threatens to annihilate the entire species. When the time for the settlement of the question of partial extermination for the benefit of the race, or total extermination by starvation, can no longer be delayed, they assemble in countless thousands in some of the mountain valleys leading into the plains, and, the vast army of martyrs being selected, they pour across the country in a straight line, a living stream, often exceeding a mile in length, and many yards in breadth, devouring every green thing in their line of march; the country over which they have passed looking as if it had been ploughed, or burned with fire. They march principally by night, and in the morning, resting during the day, but never seek to settle in any particular locality, however abundant food may be in it, for their final destination is the distant sea, and nothing animate or inanimate, if it can be surmounted, retards the straight onward tide of their advance.

When the reindeer gets enveloped in the living stream, they will not even go round its limbs, but bite its legs until, in its agony and terror, it plunges madly about, crushing them to death in hundreds, and even killing them with its teeth. If a man attempts to stem the living torrent, they leap upon his legs; and, if he lay about him with a stick, they seize it with their teeth, and hold on to it with such determined pertinacity that he may swing it rapidly round his head without compelling them to loosen their hold. If a corn or hay rick be in the way, they eat their way through it; and, on arriving at the smooth face of a rock, they pass round it, forming up in close column again on the other side. Lakes, however broad, are boldly entered, and the

passage attempted; and rivers, however deep and rapid, are forded, impediments in the water being as boldly faced as those on shore. They have been known to pass over a boat, and to climb on to the deck of a ship, passing, without stop or stay, into the water on the further side.

Their natural instincts are not in abeyance during this migration, as females are frequently seen accompanied by their young, and carrying in their teeth some one which had succumbed to the fatigues of the march, which might not be stayed until the helpless one was recruited.

Foxes, lynxes, weasels, kites, owls, etc., hover on their line of march and destroy them in hundreds. The fish in the rivers and lakes lay a heavy toll upon them, and vast numbers are drowned, and die by other accidents in "flood and field;" but the survivors, impelled by some irresistible instinct, press onward with no thought of stopping, until they lose themselves in the sea, sinking in its depths, as they become exhausted, in such numbers that for miles their bodies, thrown up by the tide, lie putrefying on the shore. Comparatively few ever return to their native haunts, but there can be no doubt that some do so, as they have been seen on the return, pursuing their backward journey in the same fearless and determined manner as their advance.

The peasants witness this dread incursion with terror. Until lately they believed that the vast horde was rained from heaven as a punishment for their sins, and during the time of their passage they used to assemble in the churches, the priests reciting prayers specially composed for such visitations. It was also believed that the reindeer ate them, and that they so poisoned the ground they passed over that they would not eat on it for a considerable time. As we have seen, the reindeer bites them with its teeth in its agony and terror, and the complete sweep they make of every blade of grass on their line of march satisfactorily accounts for its declining for a time to graze upon it.

A recent writer tells us that, in addition to this wholesale migration, which takes place about twice during a quarter of a century, smaller migrations occur, in which many are killed, while others live to return to their haunts; but as there are several species of lemmings spread over the northern regions of both the Old and the New World, he may allude to another variety than the one we have been dealing with, which is the *Mus lemmus* of Linnæus and Pallas.

The superstitious notions and wonderful reports once prevalent with regard to the lemming, as recorded by old writers, are not without interest. Olaus Magnus says:

"In the foresaid Helsingia, and provinces that are near to it, in the diocese of Upsal, small beasts with four feet, that they call Lemmar or Lemmus, as big as a rat, with a skin diverse-colored, fall out of the ayr in tempests and sudden storms; but no man knows from whence they come—whether from the re-

moter islands, and are brought hither by the wind, or else they breed of feculent matter in the clouds; yet this is proved, that so soon as they fall down there is found green grass in their bellies not yet digested. These, like locusts, falling in great swarms, destroy all green things, and all dyes they bite on, by the venome of them. This swarm lives so long as they feed on new grass. Also they come together in troops like swallows that are ready to fly away; but at the set time they either dye in heaps with a contagion of the earth (by the corruption of them the ayr grows pestilentiall and the people are troubled with vertigos or the jaundice); or they are devoured by beasts called commonly lekeirt or hermalins, and these Ermines grow fat thereby, and their skins grow larger."

Schoeffer, whom we next cite, believed that

"They sometimes make war, and divide themselves into two armies along the lakes and meadows. They seem likewise to commit suicide, for they are found suspended in the branches of trees; and they probably throw themselves in troops into waters, like the swallows."

Although prepared to believe that they hanged themselves, he did not believe that they were bred in the clouds. He says:

"Wormius thinks plainly that they are bred in the clouds; but the learned Isaac Rossius, in his notes to Pomponius Mela, corrects him and says, the reason why these animals are supposed to fall from the clouds is, because they used not to appear, but immediately after rain they creep out of their holes, either for that they are filled with water, or because this creature thrives much in rain, which opinion seems most probable to me."

Pontoppidan, writing at a later period, says:

"They multiply very fast by what we see of them, though, God be praised, but seldom, i. e., about once or twice in twenty years, when they come from their peculiar abodes. At these times they gather in great flocks together, consisting of many thousands, like the hosts of God, to execute his will—i. e., to punish the neighboring inhabitants by destroying the seed, corn, and grass; for when this flock advances they make a visible pathway on the earth or ground, cutting off all that is green, and this they have power and strength to do till they reach their appointed bounds, which is the sea, in which they swim a little about, and then sink and drown."

Pontoppidan, who had never seen the lemming alive, although he collected a large amount of interesting information, credible and incredible, regarding it, notes a holiday held in his time throughout Bergen, termed a mouse-festival, which had so far degenerated from its ancient purpose, that the peasants put on their holiday clothes and went to sleep. In former times the day was kept as a solemn fast, "to avert the plague of lemen and other mice, which some pretend have been used to fall down formerly from the clouds."

Wormius, in his treatise on the lemming, gives an exorcism used on such occasions, of which the following is a translation:

"I exorcise you, pestiferous worms, mice, birds, locusts, or other animals, by God the Father Almighty, and Jesus Christ his Son, and the Holy Ghost



proceeding from both, that you depart immediately from these fields, or vineyards, or waters, and dwell in them no longer, but go away to those places in which you can harm no person; and on the part of the Almighty God, and the whole heavenly choir, and the holy Church of God, cursing you whithersoever ye shall go, daily wasting away and decreasing until no remains of you are found in any place, unless necessary to the health and use of man, which may He vouchsafe to do who shall come to judge the living and the dead and the world by fire. Amen."

Traveling rapidly and by night, their sudden irruption into a locality, together with the complete destruction of the field and garden crops, tended to make the ignorant peasantry look upon them as a special visitation from Providence for their sins, and will readily account for the extraordinary notions held regarding them.

Many animals migrate from place to place, or take possession of new territory, when food becomes scarce; but we have only one other instance of a living creature migrating in vast numbers to certain destruction, and that is the locust. When their numbers increase beyond the food-producing powers of their natural habitat, they pour in countless millions into the colder regions beyond, smothering each other in their flight, until the ground is covered with their dead bodies to the depth of several inches, and water-courses are choked up by them, until the air is tainted with the smell of their putrid bodies for miles. None of them ever return whence they came. Their course is always onward, until those that escape death by accident are killed by the first cold weather they encounter. And in this way Nature compels, from time to time, a vast body of these creatures to an act of self-destruction in order that the species may not be annihilated. —*Abridged from Temple Bar.*

---

## THE PRIMARY CONCEPTS OF MODERN PHYSICAL SCIENCE.

BY J. B. STALLO.

### *IV.—Inertia and Force.*

**I**F we look for the speculative background of modern physical theories, we find something like this: Originally there was created, or somehow came to be, an indefinite number of absolutely hard and unchangeable particles of matter. There was also created, or somehow came to be, a number of forces, equally unchangeable—the force of attraction, the force of cohesion, heat, electric and magnetic forces, and so on. The forces began to act and continue to act upon the particles of matter, producing inorganic as well as organic forms. These particles and forces are ultimate facts of experience as well as of thought;

and the action of the forces upon the material particles is likewise an ultimate empirical datum, and therefore inexplicable. Force and matter, though presupposing each other in action, are fundamentally disparate; they are essentially distinct, and mutually irreducible entities. Matter, as such, is passive, dead; all motion or life is caused by force; and the only possible solution of the problems of physiology, no less than of physics and chemistry, consists in the enumeration of the forces acting upon the material particles, and in the exact quantitative determination of the effects produced by their action.

This statement of the tenets of the prevailing physical philosophy, to be exact, requires at most two qualifications. In the first place, the recent doctrine of the correlation and mutual convertibility of the physical forces, as a part of the theory of the conservation of energy, has shaken, if not destroyed, the conception of a multiplicity of independent original forces. And, in the second place, physiologists, like Du Bois-Reymond, recognize force as the invariable concomitant, if not the essential attribute of matter, and assume that to every constant primordial mass belongs a constant primordial quantity of force, so that the problem of physics, chemistry, and physiology, resolves itself into the quantitative determination of the mechanical interactions of material constants primarily endowed with forces acting equally in all directions, or, as they express it, constant central forces.

I have endeavored, thus far, to show that there are no absolute constants of mass; that both the hypothesis of corpuscular "atoms" and that of "centres of force" are growths of a confusion of the intellect which mistakes *conceptual* elements of matter for *real* elements; that these elements—force and mass, or force and inertia—are not only inseparable, as is conceded by the more thoughtful among modern physicists (or, as they usually, but inaccurately express it, that there is no force without matter, and no matter without force), but that neither of these elements has any reality as such, each of them being simply the conceptual correlate of the other, and thus the condition both of its realization in thought and of its objectivation to sense. The tendency to deal with these elements as separate and separately real entities is so irrepressible, however, that it is necessary to subject them to still further discussion, in order to clear up the prevalent confusion in regard to them.

Newton's original definition of inertia was in terms of force. According to him ("Principia," Definitio III.), "there is inherent in matter a force, a power of resistance, in virtue of which every body, as far as in it lies, perseveres in a state of rest, or of uniform rectilinear motion." In the definitions since Newton's time, the term "force" has usually been avoided. Thus Young ("Mechanics," p. 117) defines inertia as "the incapability of matter of altering the state into which it is put by any external cause, whether that state be rest or motion;" and similarly Whewell ("Mechanics," p. 245), as "the quantity of *matter*

considered as resisting the communication of motion." As is readily seen, all these definitions imply, nevertheless, that matter can be moved or changed only from without, by forces external to matter itself. Newton expressly ("Principia," Definitio IV.) speaks of force as "*impressed* upon a body, and as exerted upon it to change its state of rest or uniform motion in a straight line."

There is little difficulty in understanding how this language, in connection with the etymological import of the word "inertia," led to the assumption that matter is essentially passive, or, as it is commonly expressed, dead. There are other reasons for this assumption, connected with the evolution, not only of scientific concepts, properly so called, but of cosmological ideas, to which I shall have occasion, perhaps, to recur in the sequel; indeed, Newton's definitions which I have just cited are simply instances of the intellectual postulates of his time. And the mathematical treatment of mechanical problems, from the nature of its methods, necessitates the fiction that force and mass are separate and distinct terms. In general, it may be said that the assumption of the absolute passivity of matter is one of those errors which are inevitable in the progress of knowledge—one of the "clay moulds in which the bells of scientific truth are cast." But the perpetuation of this error is one of the most fatal impediments to real scientific progress in our day, and is fruitful of vagaries which are wholly incommensurable with the real state of modern scientific knowledge. Thus, Prof. Philip Spiller, the author of a very serviceable manual of physics, and a prolific writer on scientific subjects, has recently published a cosmological treatise,<sup>1</sup> whose theorems are founded upon the express proposition (*op. cit.*, p. 4) that "no material constituent of a body, no atom, is in itself originally endowed with force, but that every such atom is absolutely dead, and without any inherent power to act at a distance." It appears from the further contents of Spiller's treatise, that he not only denies force to the atoms taken singly, but that he also denies the possibility of their mutual action. He is driven, therefore, to the assertion of the independent substantiality of force; and, accordingly, he assumes force to be an all-pervading *quasi-material* presence—as he terms it, an "incorporeal matter" (*unkoerperlicher Stoff*). In utter disregard of the fundamental correlation of force and mass, Spiller identifies his force-substance with the ordinary luminiferous ether, so that this phantom, which, in the view of other physicists, is not only imponderable, but destitute of cohesive, chemical, thermal, electric, and magnetic forces (which, indeed, *must be* destitute of them if it is to serve as the mere substratum of these various modes of motion)—which therefore is, if possible, still more "dead" than ordinary ponderable matter—now suddenly, without changing its name, and without ceasing to be the substratum of luminar and other undulations, comes to be the very quintessence of all possible energy.

<sup>1</sup> "Der Weltaether als Kosmische Kraft," Berlin, Denicke's Verlag, 1873.

It may be said here, parenthetically, that all these recent attempts (to one of which, by Prof. Challis, I had occasion to refer in my second paper) to construe the apparent attractions of bodies as cases of ethereal pressure and propulsion are simply returns to the state of scientific anarchy which prevailed in celestial mechanics before Newton's time. Prof. Spiller is evidently unaware that his theory—according to which, force is an “incorporeal matter”—is nothing but a reproduction of Kepler's speculations (not to speak of the Cartesian and Leibnitian theories to which I have already alluded), in which the vortices supposed to carry the planets along with them were asserted to be an “immaterial species,” capable of overcoming the inertia of bodies. It is plain that this “immaterial species” is the same wooden iron which Spiller exhibits under the name of “incorporeal matter,” the only difference being that the absurdity of Kepler's chimera was less glaring in the hazy dawn of the mechanical notions of his time, than the extravagance of Spiller's conceit in the light of the scientific atmosphere of our day.

It is almost superfluous to say to the intelligent reader of these papers that Spiller's “dead matter” is a nonentity, inasmuch as we know nothing of material reality except through its action. And it is hardly worth while to point out in detail that the hypothesis of dead atoms is not only inadmissible, but wholly useless. Unchangeable particles destitute of gravity and all other force, even if the action of force upon them were conceivable, must be equally acted upon from all sides by the omnipresent ether, and could, therefore, in no wise help to establish differences of density, or other differences not contained in or evolvable from the ether itself. They could not even add to the extension of a body, much less to its hardness, being wholly without the power of resistance; but, waiving this, and granting for a moment that extension without resistance is possible, they would simply be bubbles of void space encysted in the universal ether, and to the differentiation of this ether alone all the phenomena of the material world would be due.

The truth is, that absolutely passive, dead matter is as unknown in experience as it is inconceivable in thought. Every particle of matter of which we have any knowledge attracts every other particle in conformity to the law of gravitation; and every material element exerts chemical, electrical, magnetic, thermic, and similar forces upon other elements which in respect to these forces are its correlates. The whole presence of matter to the senses consists in the manifestation of power, in the exhibition of force. All this has been very clearly seen and very explicitly stated by numerous physicists;<sup>1</sup> but, unfortunately, by most of them it has been speedily lost sight of in their ulterior speculations.

In what sense, then, can *inertia* be truly predicated of matter?

<sup>1</sup> Among those whose comprehension of this is clear, is M. Comte; his observations upon the subject (“*Philosophie Positive*,” tome i., p. 375, *et seq.*) merits attentive perusal.

The answer to this question will suggest itself at once to those who have properly apprehended the principle of the essential relativity of all material existence. A material object is, in every one of its aspects, but one term of a relation; its whole being is a presupposition of correlates without; all things are, figuratively speaking (if I may resort to such a figure without incurring the charge of illustrating *obscurum per obscurius*) shadows of each other. Every change of a body, therefore, presupposes a corresponding change in its correlates. If the state of any material object could be changed without a corresponding change of state in other objects without, this object would, to that extent, become absolute. But this is utterly unthinkable, and therefore utterly impossible, as we have already seen. At the same time it is also evident that, while every change of a body is thus conditioned by changes without, these latter changes are equally conditioned by it; that all material action, therefore, is mutual; that reaction is invariably equal to action. A corollary from, or rather an application of this is the well-known theorem that the forces within a body or conservative system can alter only the positions of its constituent parts, but cannot change the position of the body as a whole; and that, whenever such an internal change takes place, the momentum accruing in one direction has its counterpart in an equal momentum accruing in the opposite direction. If we apply this theorem to the universe as a whole, i. e., as a single dynamical system, and if we bear in mind that, mechanically speaking, all force properly so called, i. e., all potential energy, is energy of position, we see at once that whatever energy is spent in actual motion is gained in position—that the system, therefore, is absolutely conservative; and we are thus led, by a very simple approach, to the principle of the conservation of energy.<sup>1</sup>

After this summary discussion of the first conceptual element of matter, *inertia*, I proceed to the consideration of the other element, *force*. In the canonical text-books on physics, force is defined as the *cause* of motion. "Any cause," says Whewell ("Mechanics," p. 1), "which moves or tends to move a body, or which changes or tends to change its motion, is called force." Similarly Clerk Maxwell ("Theory of Heat," p. 83): "Force is whatever changes or tends to change the motion of a body by altering either its direction or its magnitude." Taking either of these definitions as correctly representing the re-

<sup>1</sup> If the term "force" is restricted, as it ought to be, to the designation of potential energy, or mere tension, the expression "persistence or conservation of force" becomes inaccurate; for the sum of the forces in the universe, in this sense, is by no means constant. The "persistence of *force*," or, more properly, the "conservation of energy," simply imports that the sum of actual or kinetic energy (energy in motion) and potential energy (energy of position or energy in tension) in the material universe is invariable. This, as is shown in the text, is but an amplification of the theorem that in any limited conservative system the sum of the potential and kinetic energies of its parts is never changed by their mutual actions.

ceived theories of physical science respecting the nature of force, it is manifest, irrespective of the considerations which I have presented in this and the preceding essays, that force is not an individual thing or distinct entity which presents itself directly either to observation or to thought, but that, so far as it is taken as a definite and unital term in the operations of thought, it is purely a fiction of the intellect. The cause of motion, or change of motion, in a body is simply the condition or group of conditions upon which this motion depends; and this condition, or group of conditions, as we have already seen, is always a corresponding motion, or change of motion, in the bodies, outside of the moving body, which are its correlates. Otherwise expressed, force is a mere inference from the motion itself under the universal conditions of reality, and its measure, therefore, is simply the effect for which it is postulated as a cause; it has no other existence. The only reality of force and of its action is the correspondence between physical phenomena in conformity to the principle of the essential relativity of all material existence.

That force has no independent reality is so plain and obvious that it has been proposed by some thinkers to abolish the term force, like the term cause, altogether. However desirable this might be in some respects, it is impossible, for the reason that the concept "force," when properly interpreted in terms of experience, is valid, and, if its name were abolished, it would instantly reappear under another name. There is hardly any concept which has not, in science as well as in metaphysics, given rise to the same confusion which prevails in regard to "force" and "cause;" and the blow leveled at these would demolish all concepts whatever. Nevertheless, it is of the greatest moment, in all speculations concerning the interdependence of physical phenomena, never to lose sight of the fact that the reality of force is purely conceptual, and that it is not a distinct and individual tangible or intangible entity.

How imperfectly all this is understood by the physicists of our time appears at once upon an examination of elementary treatises as well as original disquisitions on physical science. Thus the relation of force to mechanical motion is constantly spoken of as a "fact" ascertained by experience and verified experimentally beyond the possibility of question. In a learned article by J. Croll, published in the July number, 1872, of the *Philosophical Magazine* ("What determines Molecular Motion," etc., *Phil. Mag.*, fourth series, vol. xl., p. 37), it is said: "In regard to the first question (what produces motion) there is no diversity of opinion. All agree that what produces change or causes motion is force." The obvious meaning of this is that it might possibly admit of question whether material change or motion is produced by force or something else, and that physicists, on the whole, have come to the conclusion that it is produced by force. Such a question ought, indeed, to be solemnly pondered by grave



philosophers! It is like the question which Simon Sachs, in his despair, propounded to the gods: 'Who will assure us that the star, which the astronomers regard as Uranus, is Uranus in fact?'<sup>1</sup>

Physicists generally, however, are in still greater confusion as to the nature of force in another respect. Bodies are said to be *endowed* with a definite quantity of force, if not with a given number of forces; it is assumed that to every particular body or particle belongs, or in such body or particle in and by itself is inherent, an invariable measure of energy. This statement, besides involving the confusion just noted as to the reality of force, implies the assumption that force can be an attribute or concomitant of a single body or particle as such. This assumption ignores the fact, which is otherwise well known to physicists, that the very conception of force depends upon the relation between two terms at least. "Every force," says Clerk Maxwell ("Theory of Heat," p. 94), "acts between two bodies or parts of bodies." A "constant central force," therefore, as belonging to an individual atom in and by itself, is an impossibility.

We have now arrived at a point where it will be profitable to recur for a moment to the proposition of Du Bois-Reymond referred to at the beginning of my first paper, that the whole problem of physical science consists in "the resolution of all changes in the material world into motions of atoms caused by their constant central forces." The entire passage in Du Bois-Reymond's text, from which I extracted two sentences, reads as follows: "Natural science—more accurately expressed, scientific cognition of Nature, or cognition of the material world by the aid and in the sense of theoretical physical science—is a reduction of the changes in the material world to motions of atoms caused by central forces independent of time, or a resolution of the phenomena of Nature into atomic mechanics. It is a fact of psychological experience that, whenever such a reduction is successfully effected, our craving for causality is, for the nonce, wholly satisfied. The propositions of mechanics are mathematically representable, and carry in themselves the same apodictic certainty which belongs to the propositions of mathematics. When the changes in the material world have been reduced to a constant sum of potential and kinetic energy, *inhering in a constant mass of matter*, there is nothing left in these changes for explanation.

"The assertion of Kant in the preface to the 'Metaphysical Rudiments of Natural Science,' that 'in every department of physical science there is only so much science, properly so called, as there is mathematics,' is to be sharpened by substituting 'mechanics of atoms' for 'mathematics.' This was evidently his own meaning when he denied the name 'science' to chemistry. It is not a little remarkable that in our time chemistry, since it has been constrained, by the dis-

<sup>1</sup> "Das Sonnensystem, oder neue Theorie vom Bau der Welten, von Simon Sachs," p. 193, C. Fechner.

covery of substitution, to abandon the old electro-chemical dualism, has seemingly taken a retrograde step in its advance toward science in this sense. The resolution of all changes in the material world into motions of atoms caused by their constant central forces would be the completion of natural science."

How do these sentences of one of the foremost physicists of the day now present themselves to our view in the light of the preceding discussion? Atoms are absolute physical constants, or constants of mass; and I have shown that there are, and can be, no absolute constants of mass. And it is evident now, I trust, that there are similarly no constant central forces belonging to, or inherent in, constants of mass as such. Both the constants of mass and the constant forces assumed to belong to them are simply parts of the scaffolding of the intellect, when it seeks to subject the phenomena of the material world to exact mathematical determination. They are, as I have already intimated, instrumental fictions which are, for the moment, indispensable by reason of the inability of the intellect to deal with phenomena otherwise than singly and under a definite aspect. In order to effect a quantitative determination of material action, the mathematician is constrained to insulate the conceptual elements of matter and to treat them as separate and distinct terms. He is constrained to represent as discrete what is continuous, and as absolute what is relative. In this, as he knows, or ought to know, very well, he is doing violence to the fact. But this violence is harmless, provided he does not forget that what appears in abstract insulation in his formulæ exists in concrete and indissoluble union in Nature, and what he exhibits as unconditioned in thought is essentially conditioned in objective reality. The steps to all scientific knowledge consist in a series of representative fictions. When the old Greek sought to determine the properties of the circle, he began by constructing a polygon whose sides he subdivided until they were supposed to become infinitely small; and in his view every line of definite extent and form, i. e., every line which could become the subject of mathematical investigation, was composed of an infinite number of infinitely small straight lines. But he speedily found that, while this fiction enabled him to deduce a rule for calculating the area of the circle and otherwise to determine a number of its properties, nevertheless the circle and its rectilinear diameter were fundamentally incommensurable, and the quadrature of the circle was impossible. The modern analyst similarly determines the "locus" of a curve by the relation of small increments of coördinates arbitrarily established; but he is well aware that the curve itself has nothing to do with this arbitrary representation, and he very emphatically asserts the continuity of the curve by differentiating, or passing to the "limit" of, his increments—at the same time transforming his coördinates by changing their origin or their inclination, or even their system, from bilinears to polars, whenever he finds it convenient, with-

out ever dreaming that thereby he is in the least affecting the nature of the curve whose properties are under discussion. The astronomer, in calculating the attraction of a sphere upon a "material point," begins by assuming the atomic or molecular constitution of the attracting sphere, establishing a series of finite differences as one of the terms of his equation; but thereupon he takes the series to be infinite and the differences to be infinitely small, and very effectually dismantles the molecular scaffolding by integrating instead of effecting a summation of a series of finite differences. Observe: the astronomer begins with two fictions—the fiction of the "material point" (which is, in truth, a contradiction in terms), so as to insulate the attractive force and treat it as proceeding from the sphere alone, and the fiction of the finite differences representing the molecular constitution of the sphere; but the validity of his result depends upon the eventual rescission of these fictions and the rehabilitation of the fact. In like manner, the chemist represents the proportions of weight in which substances combine, as atoms of definite weight and figure, and the resulting compounds as definite groups of such atoms; and this mythical coinage has, no doubt, been serviceable in some ways. But, apart from the circumstance, avowed by thoughtful chemists themselves, that the symbols have become wholly inadequate to the proper representation of the facts, and that new representative fictions will have to be resorted to, it is important to bear in mind always that the symbol is not the fact, and that the fiction is very different from the reality. Newton derived many of the leading optical laws from his corpuscular theory of light and from the hypothesis of "fits of easy transmission and reflection." His theory for a time served a good purpose; but it proved, after all, to be but a convenient mode of symbolizing the phenomena with which he was familiar, and had to be discarded when the phenomenon of interference was observed. In 1824 Sady Carnot deduced the law of thermic action, which still bears his name, from an hypothesis respecting the nature of heat (supposed by him, as by nearly all the physicists of his time, to be imponderable matter), which is now known, or universally believed to be, erroneous. Since his time, Clausius, Rankine, Thomson, and Clerk Maxwell, have shown that thermic phenomena find a very convenient representation in the hypothesis that gaseous molecules are in a state of incessant motion; and Maxwell has even succeeded in predicting the phenomenon of the gradual cessation of the oscillatory movement of a disk, suspended between two other disks, in consequence of the friction of a gaseous medium, whatever be the degree of its tenuity, and this prediction has since been verified by experiment, just as Hamilton's prediction of conical refraction was verified by the experiments of Lloyd; but, of course, neither Clausius's and Rankine's formulæ, nor Maxwell's experiments, are conclusive as to the real nature of a gas. In all such cases science erects a scaffolding which is invariably kicked down as

soon as its work has been accomplished. And, if the scientific architects are so captivated with the scaffolding that they insist upon maintaining it intact, its eventual demolition is none the less sure in the progress of observation and experiment. Facts supply the *ictus calcis* which the theorist refuses to administer.

Du Bois-Reymond's proposition is nothing less than this, that natural science is constrained, by the law of all its methods, to exhibit the arbitrary scaffolding of the intellect as the real nature of the universe. He not only confounds the scaffolding of his intellect with its own structure, but he confounds this scaffolding with the structure of Nature. He mistakes the beams of his temporary platform for the rafters of the permanent edifice; the arbitrary masses of his mathematical calculations (the "atoms") for bricks of Nature's building; and the ropes of his scientific tackling (the "forces") for the ingenerate energy of the Universe. There are, it is true, passages in Du Bois-Reymond's lecture which may be construed as a virtual disclaimer of this, but his assumption that the limits of mathematical reasoning about atoms and their constant central forces are the irremovable bounds of all possible knowledge respecting physical phenomena, and the emphatic "*Ignoramus—Ignorabimus*," with which he concludes his lecture, utterly invalidate the disclaimer. He forgets that the framework on which he and his compeers have thus far been stationed is by no means the only scaffolding that can be devised. The spectroscope has convinced the chemist that a chemical analysis can be effected otherwise than by mixing substances in a testing-tube, and that he can react upon the gas of a distant comet as well as upon the hydrogen in the water which flows from a stop-cock in his laboratory. Modern analysis has shown that the limits of mathematical insight, which the synthetical geometrician supposed to be absolute, may be transcended indefinitely; and Gauss's and Hamilton's new conception which is now expanding into the calculus of operations, or calculus of quaternions, is opening theoretical vistas which, even to the analyst of modern times, seem next to illimitable. It is true that no mathematical wings will ever carry us into the regions of the "Absolute," and no spectroscopic vision will discern the indelible spectral bands of the "thing *per se*;" but, before we indulge in any lamentations over this fact, it may be well to examine the livery of the messenger who brings us the wonderful intelligence of the existence of these entities without all possible relation to the intellect, and to inquire of him how he became possessed of his message.

I must not be understood as asserting or intimating that our knowledge can ever be other than asymptotic to the endless and boundless fact of the universe. But there is a dogmatism of ignorance which is no less audacious than the dogmatism of sciolistic knowledge. The "*Ignoramus—Ignorabimus*" at the close of Du Bois-Reymond's lecture is at least as presumptuous as the pretended omnis-

science of a giddy metaphysician. One of the urgent needs of modern physical science is a thorough investigation of the nature, methods, and aids of scientific cognition, and thus of the nature of its real limits, chiefly in the light of the teachings of comparative philology and comparative psychology. Max Müller has happily designated the tendency to "reify" intellectual concepts (or, as Mill expresses it in nominalist phrase, to mistake names for things), as "modern mythology." But this mythology is not at all confined to ordinary language; it extends to all the formularies, including those employed in scientific research, which serve as the intellectual net-work for the delineation of physical phenomena and for the exact mathematical determination of the laws of their interdependence.

The most pressing need of modern physical science, however, is the disengagement of the facts of observation and induction from their present theoretical complications. Most of the scientific theories of our day have their root in the metaphysics of three centuries ago, and some of the materialistic speculations based upon them are redolent of the ancient culture of the Middle Kingdom. Both in physics and in chemistry (not to speak of the biological sciences), the facts have long since transcended the narrow bounds of the prevailing scientific hypotheses, and have thus been either ignored or misinterpreted. On the remaining pages of this paper I desire to direct attention to some of the facts connected with the main subject of my present inquiry—the concept *force*.

Physical forces are distributed by modern science into two classes, *molecular* and *molar* forces. Molecular forces are those which determine the internal changes of a body, while molar forces cause the motion of the entire mass. Molecular forces, therefore, are the agencies which determine the particular state of the body in its physical relations, considering it as an independent whole—or, as it is termed in modern mechanics, as an independent conservative system—while the molar forces determine the physical relations of the body to other bodies which, together with it, are integrant parts of a greater whole, i. e., of a more comprehensive conservative system.

Modern science teaches that all physical forces, molar as well as molecular, are mutually convertible. This fact is discussed and illustrated in scientific treatises without number, and its importance is duly appreciated. But there is another fact connected with it, equally well known, the significance of which is not, I think, at all realized: all force in its physical origin is molecular. The power which grinds the wheat in the mill on the stream, or which drives the steam-engines in a factory; the force which propels the cannon-ball on its path of destruction, or the vital juices in a vegetable or animal organism in their course of vital regeneration; the energy which causes the muscles of a man's arm or the vessels of his circulatory system to expand and contract—all are alike of helio-planetary origin,

and are ultimately traceable to the "molecular" movements of the conservative system of which our planet is a part. It would be a work of supererogation to attempt to prove this, or to illustrate it in detail; it is sufficient to refer the reader to the eloquent exposition in Tyndall's "Heat as a Mode of Motion," p. 447, *et seq.* (Appletons' edition).

I need not say that I use the term "molecular force" simply because it is a generally-received term, and because I am constrained to use it in order to be intelligible, but that I do not intend to commit myself by this use to the theory of the constitution of matter which it implies. In like manner I use the term "force" with the reservation that it rightfully denotes, not a substantive entity distinct from matter, but the relation of at least two particular states of matter at a given moment.

The molecular character of molar motion is evinced in numerous ways, which are almost wholly neglected and ignored by the modern physicist. To take the simplest instance: when two solids impinge, so that an exchange or distribution of their motions takes place, they contract and immediately expand again, according to the degree of their elasticity. It is unnecessary to inquire whether or not a communication of motion between two absolutely rigid bodies is possible; all bodies, of which we know any thing, are more or less elastic, and therefore contract and expand at the instant of impact. And their contraction is accompanied by the evolution of heat, by the conversion of molar into molecular motion, while in the expansion we have a reconversion of molecular into molar motion. No transfer of molar motion ever takes place without this momentary transition through the molecular phase.

Since the establishment of the doctrine of the conservation of energy and the correlation and mutual convertibility of forces, physicists have repeatedly called attention to the fact that the old interpretation of the phenomenon of an apparent destruction of force is inaccurate, and that the true interpretation of this phenomenon consists in the tracing of the evanescent molar motion into resulting molecular motion. But they fail to observe that the old notions respecting the *transfer* of molar motion, when there is no loss, are in similar need of rectification.

Now, what is this molecular motion, in the light of the insight which, as I hope, has been gained in the foregoing discussion? Simply an exhibition of the struggle involved in the formation or constitution of a body as a distinct conservative system. All molecular energy is in its nature constitutive, formative, or structural. All kinetic energy, or actual motion, represents the progress of morphological action in periodical alternations of advancing and retrograde metamorphosis. And the main problem of physical science is, not to calculate the play of atomic motions, under the sway of their constant



central forces, but to trace the differentiation and transformation of material forms as determined by the differentiation and transformation of the formative energy of the universe. In this connection, observation and experiment have brought to light a number of the most significant facts, to one of which I may be permitted to draw attention before the conclusion of this paper. Force, or, more correctly speaking, energy, is not only indestructible, like mass; it not only passes through a cycle of transformations corresponding to the metamorphic round of physical forms; it is not only specialized at even pace with the specialization of its corresponding material structures; but, just as the progressive specialization of these material structures is, on the whole, an advance in the direction of greater definiteness and more perfect concretion (in the case of inorganic bodies, generally accompanied by greater condensation): so, also, the specialization of formative energy is, on the whole, characterized by an ever-increasing intensification. Generally speaking, the more advanced the stage of material concretion, the greater the intensity of its constitutive force. Faraday has somewhere observed that the chemical force contained in a drop of water, if transformed into heat and light, would be sufficient to illuminate the heavens. Of course, this intensification of force, in proportion to the condensation, concretion, and differentiation of the forms produced by it, is not a thickening of a substantive entity, but is simply an increasing complication in the relations in the establishment of which all realization consists. The energy which forms and maintains the higher and more definite forms of material existence has to overcome and to hold its own against not only the inherent energy of the primary physical form, but against the specialized energy of the intermediate forms as well.

I ought, perhaps, to observe here that, whenever energy is seemingly destructive, it is in reality reconstitutive of a conservative system of a lower grade.

But I must not be led into discussions which belong to special science, and are in strictness foreign to my theme; and, so far as I am at liberty to enter upon these discussions, especially in the field of chemical science, they must be reserved for another article.

---

### SKETCH OF DR. J. W. DRAPER.

THE period from 1830 to 1870 is very strikingly marked in the history of science. It opens with great discoveries in electricity, and closes with very brilliant ones in light. Its middle portion is illustrated by the application of chemistry to physiology, which led to a revolution in the latter science, and indeed changed the face of

medicine. It is adorned with many great inventions, such as photography, the electric telegraph, the construction of railways, and ocean steam navigation. The great wars it has witnessed, the Franco-Italian, the Crimean, the Prusso-Austrian, the Prusso-French, and the American Civil War, have occasioned, as all great wars inevitably do, much intellectual activity and profound social changes. Among the latter are the emancipation of the vast serf population of Russia, and of four million slaves in America. But, perhaps, most important of all—partly through the increase and diffusion of knowledge, partly through more rapid and incessant national intercommunication—ideas liberal in politics and elevated in religion have asserted their sway.

The generation that lived in this period has therefore fairly performed its share in the promotion of modern civilization. There is no European nation which has not participated in this great movement—none that cannot offer a list of the names of its people who may lay claim to a part of the honor of the success. In this respect America is not behind others—she too has done her share, both as regards science and industrial inventions. Among those of her citizens who have devoted their lives to these objects, and who by their successful pursuit have done honor to the country, and won for themselves an eminent name in the world of science, is the subject of our present sketch, JOHN WILLIAM DRAPER.

He was born at St. Helen's, near Liverpool, in 1811, and received his education for the most part from private instructors. At eleven years of age he was sent to one of the public schools of the Wesleyan Methodists, of which denomination his father was a minister. He remained there, however, only two years, and was then returned to private instruction. When the University of London was opened, he was sent there to study chemistry under Dr. Turner, at that time the most celebrated of English chemists. At the instance of several of his American relatives, he came to America, and completed his medical education at the University of Pennsylvania, graduating in 1836 with so much distinction that his inaugural thesis received the unusual compliment of being published by the faculty of that university. Shortly afterward he was appointed Professor of Chemistry in Hampden Sidney College, Virginia, and in 1839 received an appointment to the same professorship in the University of New York, with which institution he has ever since been connected.

Dr. Draper's earliest scientific publications were on the chemical action of light, a subject at that time almost completely neglected. Eventually he published in American and foreign journals, or read before scientific societies, nearly forty memoirs in relation to it. It would be impossible in this short sketch to give an enumeration of the facts contained in these papers. We shall, therefore, select only a few of the more prominent ones for remark.

Of all the chemical actions of light, by far the most important

is that of the decomposition of carbonic acid by the leaves of plants, under the influence of sunshine. On this the whole vegetable world depends for its growth, and the whole animal world, directly or indirectly, for its food. The decomposition in question is essentially a deoxidation, and up to about 1840 it was generally supposed to be due to the violet rays of the spectrum, which, in accordance with the views held at that time, were regarded as producing deoxidizing actions, and were consequently known as deoxidizing rays. But this was altogether an assumption unsupported by experimental proof. Prof. Draper saw that there was but one method for the absolute solution of the problem, and that was by causing the decomposition to take place in the spectrum itself. In this delicate and beautiful experiment he succeeded, and found that the decomposition was brought about by the yellow rays, at a maximum by those in the vicinity of the Fraunhofer fixed line *D*, and that the violet rays might be considered as altogether inoperative. The memoir containing this result was first read before the American Philosophical Society, in Philadelphia, and immediately republished in London, Paris, and Berlin. It excited general interest among chemists. Even up to the present year it has furnished to the German experimenters the basis of a very interesting discussion in photo-chemistry.

In 1842 Dr. Draper discovered that not only might the Fraunhofer fixed lines in the spectrum be photographed, but that there exists a vast number of others beyond the violet, which up to that time had been unknown. He also found three great lines less refrangible than the red, in a region altogether invisible to the eye. Of these new lines, which more than doubled in number those of Fraunhofer, he published engravings. He also invented an instrument for measuring the chemical force of light—the chlor-hydrogen photometer. This was subsequently extensively used by Bunsen and Roscoe in their photo-chemical researches. In their paper, read before the Royal Society, in 1856, they say, “With this instrument Draper succeeded in establishing experimentally some of the most important relations of the chemical action of light.”

Most of the papers he had written up to 1844 were in that year collected and published together, in a book bearing the title of a treatise on “the Forces producing the Organization of Plants.” In this there are a great many experiments on capillary attraction, the flow of sap, endosmosis, the influence of yellow light on plants, etc.

His memoir “On the Production of Light by Heat,” published in 1847, was an important contribution to spectrum analysis; among other things it gave the means for determining the solid or gaseous condition of the sun, the stars, and the nebulæ. In this paper he established experimentally that all solid substances, and probably liquids, become incandescent at the same temperature; that the thermometric point at which such substances are red-hot is about 977° Fahr.; that the

spectrum of an incandescent solid is continuous, it contains neither bright nor dark fixed lines; that from common temperatures up to 977° Fahr. the rays emitted by a solid are invisible, but at that temperature they impress the eye with the sensation of red; that the heat of the incandescing body being made continuously to rise, other rays are added, increasing in refrangibility as the temperature ascends; and that, while the addition of rays so much the more refrangible as the temperature is higher is taking place, there is an augmentation in the intensity of those already existing.

This memoir was published in both American and European journals. An analysis of it was read in Italian before the Royal Academy at Naples, July, 1847, by Melloni, which was also translated into French and English.

But, thirteen years subsequently, M. Kirchhoff published, in a very celebrated memoir, considered by many as the origin of spectrum analysis, and of which an English translation may be found in the *London and Edinburgh Philosophical Magazine*, July, 1860, the same facts under the guise of mathematical deductions, with so meagre a reference to what Draper had done that he secured the entire credit of these discoveries. In an historical sketch of spectrum analysis subsequently published, Kirchhoff avoided all mention of his American predecessor.

Dr. Draper was the first person who succeeded in taking portraits of the human face by photography. This was in 1839. He published a minute account of the process at a time when in Europe it was regarded as altogether impracticable. He also was the first to take photographs of the moon, and presented specimens of them to the New York Lyceum of Natural History, in 1840.

In 1841 the University of New York established its medical college, Dr. Draper being appointed Professor of Chemistry in it. A very great change in medical studies and teaching was at that time impending. The application of chemistry to physiology was about to be made by Liebig and his school. In these new views Dr. Draper completely coincided, and therefore soon afterward physiology was added to his chair. He now resumed his early chemico-physiological researches, and eventually published the result of them in "A Treatise on Human Physiology, Statical and Dynamical." This work at once became a standard text-book in American colleges. It has passed through a great many editions, and was translated into several foreign languages. The Russian edition is used in the higher schools of that country.

It is impossible in our limited space to give an adequate account of the new facts and the important views, founded on extensive and expensive series of experiments, contained in this work. Among them, however, we may mention, an explanation of the selecting action of membranes; electrical theory of capillary attraction; cause

of the coagulation of the blood; theory of the circulation of the blood; explanation of the flow of sap in plants; endosmosis of gases through thin films; measure of the force of endosmosis; respiration of fishes; action of organic muscle-fibre of the lungs; allotropism of living systems; new facts respecting the action of the skin; functions of nerve-vesicles and their electrical analogues; function of the sympathetic nerve; explanation of the action of certain parts of the auditory apparatus, particularly the cochlea and semicircular canals; new facts respecting the theory of vision and theory of muscular contraction. The special object of the book was, to apply physical theories in the explanation of physiological facts, to the exclusion of the so-called vital principle of the old physicians.

Dr. Draper is a man of a philosophical cast of mind, by which he was drawn to the study of phenomena in their more comprehensive aspects and relations. The wide range of his scientific acquirements, and especially his mastery of physiology, formed an admirable preparation for studying the subjects of human development and the course of civilization from a scientific point of view. His "Physiology" was accordingly soon followed by a work of which the intention was to show that societies of men advance under the government of law. This was entitled "A History of the Intellectual Development of Europe." Few philosophical works have attained so quickly to celebrity. Many editions of it have been published in this country, and it has been translated into almost every European language. The *Westminster Review*, speaking of it says: "It is one of the not least remarkable achievements in the progress of positive philosophy that have yet been made in the English tongue. A noble and even magnificent attempt to frame an induction from all the recorded phenomena of European, Asiatic, and North African history."

Though in his earlier years Dr. Draper was a skillful mathematical analyst, he has published but few mathematical papers, the most important being an investigation of the electrical conducting power of wires. This was undertaken at the request of Prof. Morse, at the time he was inventing his telegraph. The use made by Morse of this investigation is related by him in *Silliman's American Journal of Science and Arts*, December, 1843. The paper shows that an electrical current may be transmitted through a wire, no matter what the length may be, and that, generally, the conducting effect of wires may be represented by a logarithmic curve. Among electrical memoirs there is one on the tidal motions exhibited by liquid conductors, and one on the electro-motive power of heat, explaining the construction of some new and improved forms of thermo-electric batteries. An abstract of these improvements is given in the last edition of the "Encyclopædia Britannica" (Art. Voltaic Electricity).

Dr. Draper was the first person to obtain photographs of the diffraction spectrum given by a grating, and to show the singular advan-

tages which that spectrum possesses over the prismatic investigations on radiations. In a memoir on the production of light by chemical action (1848), he gave the spectrum analyses of many different flames, and devised the arrangement of charts of their fixed lines in the manner now universally adopted. A memoir on phosphorescence contains the experimental determination of many important facts in relation to that property. Among purely chemical topics he has furnished a method for the qualitative determination of urea by nitrous acid.

In 1864, at the request of the New York Historical Society, Dr. Draper gave four lectures before that body, which were subsequently published under the title of "Thoughts on the Civil Policy of America." They were respectively on the influence of climate upon man; on the effects of emigration; on the political force of ideas; and on the natural course of national development. They contain discussions of several interesting points, which since that time have largely occupied public attention, such as the internal emigration from the Atlantic States to the West, the Asiatic emigration to the Pacific States, the political effects of polygamy in Utah, the tendency of democratic institutions to centralization, a comparison of the European with the American method of government.

No account of Dr. Draper's labor and influence for the promotion of science would be complete that did not mention the admirable series of Introductory Lectures with which he opened his chemical courses in New York from 1840 to 1850. Clear in statement, fresh and striking in their views, and lively, poetic, and witty, as well as instructive, they were well fitted to awaken the enthusiasm of students. Those on "Oxygen," "Atmospheric Air," "Water," and "Phosphorus," were especially brilliant. We have repeatedly tried to induce their author to have them collected and reprinted, but he says they were only fragments designed for a transient purpose, and are not worth preserving in a permanent form. Dr. Draper's manner as a lecturer is quiet and deliberate—too subdued and equal for stirring effect, but perfect for exposition. As a speaker, he has been rarely drawn out of the collegiate sphere, but such efforts as his Introductory Lectures and his felicitous address at the Tyndall banquet show that he has the elements of humor and an art of putting things that would have given him success in the popular field if he had cared to seek it.

From 1860 to 1870 Dr. Draper did but little in scientific research, devoting himself mostly to historical works. During this time he published his "History of the American Civil War," in three volumes. His opportunities for giving accuracy to this work were very great. Mr. Stanton, the Secretary of War, issued orders to the Adjutant-General of the Army of the United States to "furnish him with copies of all orders, reports, correspondence, telegraphic dispatches, or other documents on file in the War Department, as he might request, and to permit him to inspect and have copies of any maps, plans, and other pa-



pers necessary for the preparation of his work, and to furnish him with statistical information respecting the armies of the United States, their organization, and operations." This order included all the Confederate archives in possession of the War Department. Nor was the interest of the Secretary of War limited to this: he supplied also a large amount of personal information of the utmost value. Access was not unfrequently given him to documents and correspondence of the most confidential kind, with a view of guiding him to correct conclusions, and many of the most decisive military operations are detailed from private memoranda furnished by the commanding officers themselves. As was the case with Dr. Draper's other works, this also has been largely republished in Europe.

In the summer of 1870 Dr. Draper suffered a severe bereavement in the loss of his wife. Of Brazilian birth, she was connected with an ancient and noble Portuguese family. She had rendered his domestic life a course of unbroken happiness, and doubtless she was the exemplar before his eyes when he wrote that often-quoted passage in his "Physiology," in which, after depicting the physical and intellectual peculiarities of woman, he says: "But it is in the family and social relations that her beautiful qualities shine forth. At the close of a long life checkered with pleasures and misfortunes, how often does the aged man with emotion confess that, though all the ephemeral acquaintances and attachments of his career have ended in disappointment and alienation, the wife of his youth is still his friend. In a world from which every thing else seems to be passing away, her affection alone is unchanged, true to him in sickness as in health, in adversity as in prosperity, true to the hour of death."

Of their six children, one died in infancy; the survivors are three sons and two daughters. Of the former, the eldest is Professor of Natural History in the College of the City of New York; the second, Professor of Physiology in the University of New York; the third, Director of the Meteorological Observatory in the New York Central Park.

After the death of his wife, Dr. Draper spent the following winter in Europe, chiefly in Rome. Since his return he has published two short memoirs: one, on the "Distribution of Heat in the Spectrum," showing that the predominance of heat in the less refrangible regions is due to the action of the prism, and would not be observed in a normal spectrum, such as is formed by a grating; and that all the rays of light have intrinsically equal heating power. The second is an investigation of the distribution of chemical force in the spectrum. All these scientific researches, to which so many years of his life have been devoted, have been at his own expense; he has never received any extraneous aid, though many of them have been very costly. He has never taken out any patent, but has given the fruits of his investigations and inventions freely to the public.

## EDITOR'S TABLE.

*MILL, EDUCATION, AND SCIENCE.*

THE first part of Mr. Mill's autobiography gives an instructive account of his early education. He had before propounded his general views upon this subject in a celebrated address delivered at the University of St. Andrew's in 1867. Mr. Mill had won the enviable distinction of possessing "the most elaborated mind in Europe," and this, together with the confessed ability of his argument, gave it wide influence with the public. But there were many who thought that Mr. Mill, on that occasion, reasoned too much from his own exceptional experience, and that, as an argument addressed to the times, the performance was misleading and injurious. The record of Mr. Mill's mental history, now published, throws important light upon the view promulgated at St. Andrew's, and, as the question involved is of great practical importance, the present is a fitting occasion to offer some remark upon it.

There has grown up a grave conflict between ancient learning and modern science as means of educating the human mind. It originated in the rise of a new order of knowledge derived from the extensive study of Nature in recent times. The old system was, however, strongly entrenched in the field of education; it was interwoven with the world's literature, and all its venerated traditions; it appealed to the generations of the great that it had trained, and it was in possession of the old institutions of learning, fortified by rich endowments, and backed by state and church. But, as modern knowledge has grown in extent and influence, and institutions have been liberalized, and the idea of general education has

become a part of civilization, there has been a growing demand for the right of science to have a more decisive voice in education, and this demand has been partially yielded to by the modification of old methods and the establishment of new. Such changes have only resulted from long and earnest conflict between opposing views, and, whatever may be the merits of this controversy, one thing would seem to be certain, that it has been a natural and inevitable outgrowth of the progress of events.

At the outset of his address, Mr. Mill recognized this struggle as "the great controversy of the present day, with regard to the higher education, the difference which most broadly divides educational reformers; the vexed question between the ancient languages and the modern sciences and arts." But, from Mr. Mill's point of view, the antagonism is unreal, and the controversy futile and groundless. Between the two systems of culture he acknowledged no rivalry, but said, "Why not both?" To the obvious answer that average students have neither capacity nor time for such extensive mental conquests, he indignantly replied: "I am amazed at the limited conception which many educational reformers have formed to themselves of a human being's power of acquisition." Mr. Mill, accordingly, proceeded to outline a system of study more consonant, as he thought, with the powers and possibilities of the human mind. The limitations of capacity assigned by experience and embodied in practical plans of education he gave to the winds, and offered an ideal of scholarship and a range of acquisition of most majestic proportions. But it was so grandly

his own, and so out of all relation to the hard workaday facts of college and university life, that it practically served little other purpose than to confirm a bad state of things, and to put a new weapon into the hands of the educational obstructives. Let us see how this result was effected.

Mr. Mill began by enforcing the largest claims of ancient learning. He outstripped all contemporaries in the extent and rigor of his classical exactions. He refused a place to modern languages in the collegiate course, saying that these can be best studied in the countries where they are spoken, while three or four of them can be easily picked up after the classical tongues have been secured. With the modern languages modern literature was also ruled out. "The only languages, then, and the only literature," says he, "to which I would allow a place in the ordinary curriculum are those of the Greeks and Romans, and to these I would preserve the position in it which they at present occupy." The reasons which he offered for studying Greek and Latin were far from being the stock-reasons that we are accustomed to hear. These languages are to be acquired for the purpose of mastering their literary contents. Not for any such slight considerations as the bearings of the classical languages upon English, or to be able to understand current quotations, or for the mere discipline of lingual study, are they to be acquired, but that the student may enter into the spirit and breathe the atmosphere of ancient life. He is to be at home in Greek and Roman thought as he is in that of his native speech. "We must be able in a certain degree to think in Greek if we would represent to ourselves how a Greek thought; and this not only in the abstruse region of metaphysics, but about the political, religious, and even domestic concerns of life." Translations are not to be accepted. Though the profoundest schol-

ar, after life-long preparation, renders an ancient author into English, the student of the "ordinary curriculum" must be able to translate it better for himself. He must not trust to other person's impressions, but must have every thing at first hand, and go directly to the fountain-head. Greek and Latin must be studied, that the student may get at the original materials of history, so as to check and correct the historians. The modern classics, English, German, and French, are insufficient as models; those of Greece and Rome are more perfect, and therefore the student must use them to form his style and perfect his literary taste.

Mr. Mill then went on to argue the claims of the sciences, but his work was superfluous. Methuselah might have listened to him with interest, but practical men knew that the demands he had already made were far beyond the possibilities of realization by general students in the usual period of study. Already he had laid out a scheme of professional scholarship not attainable in its completeness by one in a hundred of those who give their lives to it. Mr. Mill's words, to be sure, were hot with scorn when he referred to the "shameful inefficiency," and "wretched methods," and "laborious idleness," of current classical teaching—the constant fruits of the system for centuries, as testified to by similar denunciations of the most eminent men. But he did not say, "Improve these methods or get them out of the way." On the contrary, he indorsed unqualifiedly Greek and Latin studies in "the position which they at present occupy;" and, to carry out his views, nothing remained but to give them a greatly-increased attention. The practical effect of his argument was, to lend renewed and powerful support to the classical system as it now exists, and this was the general interpretation given to the address. It was universally hailed as a triumph of the classical party, and thrown in

the face of the friends of scientific education as a final refutation of their case. It was a victory of the classicists simply because it gave them every thing they asked. If they could have classical studies assured on such a scale as Mr. Mill proposed, there was no longer any fear of scientific encroachment. Already in possession of the appliances of education in existing institutions, if his programme is accepted, they will always remain in possession. Mr. Mill said, "Why not both?" But his argument was a practical surrender to one side, because, on his scale of study there is not time for both, and the party that comes first gets all.

The question now arises, Was this exalted estimate of classical studies the result of an impartial survey of the field of knowledge and an equal appreciation of science, or of an overwhelming bias produced by a one-sided training, of which Mr. Mill had been the victim in his youth? The Autobiography here comes to our assistance, and we learn from it the following extraordinary facts:

Mr. Mill's father was a man of great intellectual vigor, and a disciplined scholar, and he determined to make his son an example of the most thorough and perfect form of education. Critical, vigilant, and exacting, he took entire charge of the boy's studies. Fortunately, the lad had great native capacity, and a fine, tenacious organization, and his proficiency equaled his father's efforts and expectations. At three years old he commenced the study of Greek, and only faintly remembers going through Esop's "Fables" in that language. He then read the "Anabasis," and, before he was eight years old, he had read all the nine books of Herodotus, the first six "Dialogues" of Plato, all Xenophon's "Cypædia," the "Memorabilia" of Socrates, and portions of Diogenes Laertius, Lucian, and Isocrates. During this

time he also learned arithmetic, and read the histories of Robertson, Hume, Gibbon, Watson, Hooke, Rollin, Burnet, Langhorne's Plutarch, Millar's "Historical View of the English Government," Mosheim's Ecclesiastical History, and various other ponderous books; nor were these merely cursory or desultory readings. His father required every day a full account of what he had read. Notes, abridgments, and synoptical statements, had to be made, and in their daily walks the father enforced the lessons, and gave him explanations and ideas on various questions of civilization, government, mental philosophy, and morality; and all this the son was required afterward to reproduce in his own words.

Amazing as was the work done up to his eighth year, it increased, in a most oppressive ratio, in the next four years. English and Greek being not sufficient, he now went into Latin, and, as he acquired it, taught it to his brothers and sisters. Between his eighth and twelfth year, he read Virgil, Horace, part of Livy, the whole of Salust, parts of Ovid, Terence, Lucretius, Cicero, the "Iliad" and "Odyssey," one or two Greek plays, the whole of Thucydides, Aristotle's "Rhetoric," Tacitus, Juvenal, Quintilian, and the principal "Dialogues" of Plato. From ten to eleven he wrote a "History of Rome" that would have filled an octavo volume. He also learned elementary geometry, algebra, the differential calculus, and other parts of the higher mathematics. Logic, and the "Organon" of Aristotle, had not been neglected; and, at thirteen, he corrected the proof-sheets of his father's "History of India," and went through with him a complete course of political economy, being required to correct "the more superficial views of Adam Smith by the superior lights of Ricardo." Of course, the boy was kept to the inexorable drill, upon subjects selected by his father; but, in his spontaneous reading,

he says that his strongest predilection was ancient history. "A book which, in spite of what is called the dryness of its style, I took great pleasure in, was the 'Ancient Universal History,' through the incessant reading of which, I had my head full of historical details concerning the obscurest ancient people; while, about modern history, except detached passages, such as the 'Dutch War of Independence,' I knew and cared comparatively little."

And so young Mill became a prodigy of Greek, Latin, and antiquated learning. The dead languages and their contents were fairly burned into his organization. On his classical acquisitions were superinduced history, mathematics, metaphysics, and political ideas—studies which he might have pursued if he had been the son of Plato instead of James Mill. But of the sciences of Nature there was nothing gained worth the name. At the mental stage in which all the foregoing acquirements had been made he had received not the slightest scientific instruction, and had only read a little in experimental books by way of amusement. He says: "During this part of my childhood, one of my greatest amusements was experimental science, in the theoretical, however, not the practical sense of the word; not trying experiments—a kind of discipline which I have often regretted—nor even seeing but merely reading about them." Mr. Mill subsequently paid more attention to science by reading; he heard lectures on zoology and chemistry, and did something with botany as an observer and collector. But of science in the educational sense of the classics, as an agency to mould the mind by its special discipline, he was utterly destitute. He neither pursued it in its objects, nor mastered it in its principles, nor cultivated the habit of original and independent research. The whole spirit of his education, indeed, was different; it was for polemics rather than for discov-

ery. The intellectual exercise in which he says he was most perseveringly exercised by his father was the old scholastic logic, which he thinks is "peculiarly adapted to an early stage in the education of philosophical students, since it does not presuppose the slow process of acquiring by experience and reflection valuable thoughts of their own." His training was fitted to make him shine in debating societies, of which he was a frequenter, and he organized one at the age of sixteen. And such was his proficiency that, it was said, "a university man, loaded with honors and preceded by a blazing reputation, having been induced, in an evil hour, to take the chair at a discussion, crumbled to dust in the presence of our Titan, and passed out of count utterly."

The effect of neglect of science in Mr. Mill's education is seen in his remarkable judgment of himself. In his Autobiography he makes the astounding statement that in "natural gifts I am rather below than above par; what I could do could assuredly be done by any boy or girl of average capacity," and he assumes to have had the start of his contemporaries for a quarter of a century, simply from the mode in which he was instructed. Mind is thus dealt with as if it were a disembodied agency capable of being manipulated into any state; while organic conditions and limitations, and the influence of heredity, are discredited at a stroke. No allowance is made for the fact that he derived his fine organization from a father of great intellectual capacity; yet, nothing is better established by science than that traits of character are transmissible, and that this circumstance bears powerfully upon the problem of human educability. Physiologists well know that the children of cultivated parents not only inherit superior mental aptitudes and capacities, but that they have greater power of psychical endurance, and can

stand far greater mental exertion without injury, than the children of uncultivated parentage. Such a discipline as young Mill underwent would have reduced most children to idiocy, or killed them outright. Mr. Mill was an eminent student of mind, but it is very clear that he dealt with it from the ancient point of view, and knew very little of or cared very little for what modern science has had to say about it.

And even he, with his tough and vigorous organization, barely escaped the consequences of such gross error reduced to practice. At twenty he passed into a cloud of gloom and despondency. He became indifferent to his pursuits, sleep brought no relief, and he had thoughts of suicide. He became painfully anxious, under the notion that, if all he had been striving to attain could be realized, there would be nothing left to live for. Brain-disturbance from overtaking was evinced by delusion, like that of Martyn, who, when he had come out Senior Wrangler, was taken with the crazy fancy that mathematics were an invention of Satan, and that he had been led into a net of destruction. Mr. Mill had evidently reached the verge of a cerebral break-down, when he changed the course of his mental action by going into emotional literature, and ascribed his escape to Wordsworth's poetry. Had he been as deep in physiology as he was in Greek, and made use of his knowledge, this dangerous state might not only have been better interpreted, but probably quite avoided.

When, therefore, Mr. Mill, some fifty years later, in chalking out a system of education for the students of St. Andrew's, said of ancient and modern knowledge, "Why not both?" he was himself a living refutation of its possibility. He had worked himself up to the very breaking-point in the enormous accumulation of classical and other acquisitions, while modern thought had not been correspondingly mastered.

The law of mental limitations, by which one thing can only be had at the expense of another, was in as full force in his case as in that of inferior minds; and his classical surcharging involved a correlative deficiency in science which has unquestionably been an element of weakness in his own career. We do not deny that Mr. Mill had a very considerable acquaintance with science, and only insist that it was neither up to his own standard of thoroughness in other departments, nor was it sufficient for his own requirements as a thinker ambitious of controlling the mind of his age. His book on "Logic," undoubtedly a great work, would have been a greater if a part of the effort spent upon classical history had been given to the history of science. But, while demanding that students shall learn dead languages, to get at the originals of political history, he was content, or rather he was compelled, to take scientific history at second-hand.

Such was the deficiency of the work in this respect that, although, as Mr. Mill states in the Autobiography, Prof. Bain "went carefully through the manuscript before it was sent to press, and enriched it with a great number of additional examples and illustrations from science," yet it was exposed to the telling criticisms of Dr. Whewell, the eminent historian of science, for the faulty and ill-chosen character of the instances of discovery selected to exemplify and confirm his methods.

Mr. Mill was at the head of a school of thinkers which maintained what is called the Experiential Psychology; that is, in Mr. Mill's language, "there is not any idea, feeling, or power, in the human mind, which, in order to account for it, requires that its origin should be referred to any other source than experience." The problem of mind, as thus conceived, is one of the grandest openings of modern thought. Be the doctrine true or false, it brings



the study of mental phenomena into more close and vital relations with the surrounding universe than had been possible with the older metaphysical views. James Mill was the author of the ablest exposition of this doctrine that had yet appeared; and his son, therefore, through his father's early and able teaching, had the rarest advantages for pursuing the inquiry and occupying the field. But another and a younger man came into that field, and took possession of it. At the age of thirty-five, Mr. Herbert Spencer published his "Principles of Psychology," of which Mr. Mill himself says, "it is one of the finest examples we possess of the psychological method in its full power." Subsequent criticism has strengthened this judgment, and assigned to that work an unrivaled position in the original psychological literature of its time. Mr. J. S. Mill's greatest work upon mind is undoubtedly his polemical criticism of Sir William Hamilton; but, after this was published, and the works of Spencer and Mill were left to their influence upon the British public, Prof. Masson, in a lecture before the Royal Institution, gave expression to the growing conviction concerning Spencer, that, "if any individual influence is visibly encroaching on Mill's in this country, it is his."

What, now, was the secret by which Mr. Spencer was enabled to beat Mr. Mill in the field where he was most at home, and had every apparent advantage? It was simply the difference in the education of the two men. Both were examples of great native power of mind; both were educated by their fathers, and neither went to the universities. But while Mill was sent back in childhood to the world of two thousand years ago, and spent his force in learning half a dozen languages, and in loading himself down with the erudition of antiquity, Mr. Spencer was content with his English, left antiquity

to itself, and entered in childhood into the sphere of modern thought. Mr. Mill had spent his energies on his splendid scholastic preparation, and could give only the remnant of his powers to the profounder intellectual movement of his own time. Mr. Spencer broke freshly into the study of Nature and science, unperverted by ancient ideas, and unincumbered by antiquated learning, and was thus enabled to make those extensive modern acquisitions by which he has attained such power over the thought of his own time. While Mr. Mill was drilling with the school logic, which calls for no original thought, Mr. Spencer was making discoveries in experimental science, and forming his own opinions on the basis of the most recent knowledge; and while, in the study of mind, Mr. Mill sunk into little better than a mere commentator on his father's ideas, Mr. Spencer took up the great question from his own independent point of view, and has given his contemporaries, perhaps, the most original contribution of the century to the science of mind. Wherever the two men are brought into comparison, the enormous advantage of Spencer, through his mastery of scientific thought, is confessedly apparent. Mr. Mill wrote a formal work upon the woman question, as he might have written it two thousand years ago, and as if science had contributed nothing that is valuable in its elucidation: Mr. Spencer has lately crossed the field, treating the psychology of the sexes incidentally, and, as a contemporary remarks, his brief sketch makes the "Subjection of Woman" appear "obsolete and antediluvian" in comparison with it.

The question that Mr. Mill put to the students, "Why not both?" finds thus a sufficient answer in his own career. "Both" are impossible; and Mr. Mill gave himself to the past, at the expense of the future.

## LITERARY NOTICES.

REPORT OF THE GEOLOGICAL SURVEY OF OHIO. Vol. I., GEOLOGY AND PALEONTOLOGY. Part I., GEOLOGY; Part II., PALEONTOLOGY. Published by authority of the Legislature of Ohio. Columbus, 1873.

THESE two octavo volumes, which together form the first volume of the final report on the survey of Ohio, mark an important advance in the scientific knowledge of the character, history, and resources of our country. Since the survey was undertaken in 1869, three preliminary reports have appeared, giving the progress of discovery and labor for each year, and containing much valuable and interesting information. But here we have the beginning of the end, the first installment of a series which is to comprise some six volumes, and which will be a model in many respects for similar works in years to come.

As long ago as 1836 an attempt was made to have a geological survey in Ohio, and two annual reports of progress were published under the direction of Prof. W. W. Mather and Dr. S. P. Hildreth, together with several other gentlemen since eminent in geological study. The panic of 1837, however, caused the abandonment of the work by the Legislature, a mistaken economy which much retarded and impaired the development of the resources of the State. It was not until 1869 that the enterprise was resumed, and placed in the hands of the very able corps of gentlemen who have so well performed their work.

At the head of the survey was placed Dr. John S. Newberry, whose ability has found full scope, and whose reputation has gathered new laurels in this honorable service to his own State. Associated with him are gentlemen of high standing and capacity, Profs. E. B. Andrews, Edward Orton, and J. H. Klippart, as assistant geologists, and Dr. T. G. Wormly as chemist; while the work of paleontology has been divided between Dr. Newberry and Prof. F. B. Meek, so well and widely known in this especial department.

The second volume, soon to appear, will be composed, like the first, of two separate parts, on geology and paleontology; the

third volume will treat of the economic geology of Ohio; and the fourth, of its agriculture, botany, and zoology. Part I. of the first volume has some of the mechanical defects that generally appear in public documents issued by State printers; but Part II. is a fine specimen of a book. A very large edition was voted by the Legislature, for the purpose of making the work familiar to the people of the State; and Dr. Newberry has been most successful in his endeavor to render the subjects treated of plain to all intelligent readers, so that these reports may be not only a treasure-house for students of science, but a means of information and instruction for the people at large.

The first part, on geology simply, forms an octavo of 680 pages. It opens with some general discussions, which properly introduce such a volume, and then passes on to the local details by counties. To any but specialists in geology, the general chapters in the First Section will possess the chief amount of interest; but there are doubtless many professional students of the science who could derive great benefit from these unpretending but masterly pages. After a brief sketch of the history of the survey, Dr. Newberry gives four chapters treating respectively of the physical geography of Ohio, of its geological relations to the rest of the country, and of its geological structure through the Silurian and Devonian formations.

Those who are acquainted with Dr. Newberry's cast of mind and method of treatment, will recognize these chapters as eminently characteristic, in the wide range and striking power of their generalizations, and the clearness of statement which pervades them. The second chapter, on the Physical Geography of Ohio, is in reality a brief but admirable summary of the physical geography of North America. Its discussion of the important question of the relation of forests to rainfall should be read by every intelligent man. With few exceptions, all students of science are agreed as to the destructive effects produced upon climate by the removal of woods from a country. This lesson cannot be too soon or too earnestly pressed upon the attention of our people and our

governments, both State and national. It has been held by some that the removal of forests causes an actual lessening of the annual rainfall; but this view is hardly borne out by recorded observations. The same injury, however, is equally accomplished in a somewhat different way. The removal of timber lays the ground open to rapid evaporation, and, worse still, causes the surface covering of earth, mould, etc., to be washed away from the unprotected sides of hills and mountains. The consequence is that the same yearly amount of moisture, instead of being slowly and gradually discharged by the brooks and streams, rushes away in destructive torrents and freshets, such as are all too familiar every spring, when the winter's snow is melting. The water-supply being thus lost all at once, the steady streams and rivers of a generation or two past dwindle in the summer to fitful and worthless rills. Such is the harvest of disaster from "our great lumbering interest."

Chapter III., on the "Geological Relations of Ohio," is yet more interesting in a purely scientific aspect. It begins with a brief outline of the characteristic features of the several great periods of geological history, as represented by the deposits in North America. Here Dr. Newberry gives, in a popular form, the gist of his discussion lately presented to the American Association of Science at Portland, and more recently to the National Academy of Arts and Sciences, at its session in this city in October last, on "Cycles of Deposition in Sedimentary Rocks," a generalization unsurpassed for its beauty, its simplicity, its wide-reaching grasp, and its lucid explanation of a multitude of details, previously insignificant and often wearisome.

Each of the great ages of palæozoic geology—the two Silurians, the Devonian, and the Carboniferous—represents, in this view, a grand invasion of the sea upon the land, slowly spreading itself over the continent, mainly from the west and south, and laying down a series of sediments in a fixed and regular order, depending on the increasing depth of the advancing waters. No one, it would seem, can look at the facts in a broad and philosophical view, excluding of course the thousand details which cause

partial modifications in every such great operation of Nature, without recognizing here a new light cast upon the hitherto unmeaning succession of varying kinds of deposits.

The remainder of this volume is occupied with the detailed description of the geology of twenty-one counties—nearly one-fourth of the State—by Profs. Andrews and Orton, Dr. Newberry, and Messrs. M. C. Read, G. K. Gilbert, and N. H. Winchell, assistants. While all these accounts are full of valuable matter, especial interest attaches to Prof. Orton's excellent account of the lower Silurian formation, known in Ohio as the Cincinnati Group, and to Mr. Gilbert's summary of the surface geology of the Maumee Valley, which is rich in remarkable illustrations of the effects of the great sheet of ice, and afterward of the broad expanse of water, which overspread so much of our northern country during the several parts of the great Glacial Epoch. Dr. Newberry's sketch of Cuyahoga County, the region around Cleveland, also treats of the same fascinating subject; and Prof. Andrews gives quite a chapter of "Conclusions, Theoretical and Practical," on the mode of formation of different varieties of coals.

It only remains to refer briefly to the second volume or second part of Volume I., which treats of the paleontology of Ohio. This work, somewhat larger than the first part, comprises three divisions, as follows: the "Invertebrate Fossils of the Silurian and Devonian Formations," by Prof. F. B. Meek; the "Fossil Fishes of the Devonian Group," by Dr. Newberry; and the "Fossil Plants of the Coal Period" (in part), also by Dr. Newberry. With the exception of these last, the present volume includes only the fossils below the carboniferous rocks.

In these chapters, a great and permanent work has been accomplished for science, in the accurate description and classification of a very large number of interesting fossils, heretofore either undescribed, or described so imperfectly as not to be reliable as a basis for study. The crinoids, mollusks, brachiopods, and trilobites, have been well intrusted to Mr. Meek; whose full and careful discussions are accompanied with an admirable series of plates.

The most remarkable part of this volume, however, is that relating to the fossil fish of the Devonian Age. This period, as is well known, has long been called the "Reign of Fishes," from the great variety of singular and grotesque forms of fish-life which then appeared and peopled the ancient seas. The greatest share in bringing to light this extraordinary series of by-gone types was borne by Hugh Miller, whose discoveries in the "Old Red Sandstone" of Scotland have won for him imperishable fame in the annals of science. The continuation, on this continent, of Miller's discoveries abroad, is here given to the world; and it is no less remarkable, perhaps indeed more so, than were his. The series of fish here described forms an extraordinary addition to our knowledge of the life of the past. The Devonian waters that spread over what is now the greater part of Ohio were inhabited by a strange race of literal sea-monsters, singular in form and gigantic in size, plated and mail-clad, and bearing all manner of elaborate weapons for offense and defense. Among them we may refer to the tribe of Chimæroids, allied to the sharks, now represented only by a few rare species, and which, though well known to have existed in later formations, has never before been discovered in palæozoic rocks. Dr. Newberry has described the new genus *Rhynchodus*, with several species belonging to this group. Still more singular, however, are several genera of ganoid fish, of which only one or two can be referred to here. One of these is *Onychodus*, which carried at the extremity of its lower jaws, where the two rami meet, a vertical set of long, radiating teeth, projecting like the piercing prow of an iron-clad ram. This form is wholly novel. Another is *Deinichthys*, the giant of the period, whose tremendous jaws, shaped like sled-runners, were a couple of feet in length; while the bony buckler that covered the back was from one to two inches in thickness!

But time would fail us to dwell on these interesting accounts; and we can only express our gratification that so much important discovery is now announced and recorded in a permanent form, and congratulate both the gentlemen of the survey and the people and government of Ohio on this

great work now so auspiciously approaching its close.

AUTOBIOGRAPHY OF JOHN STUART MILL.  
New York: Henry Holt & Co. 313 pp.,  
8vo. Price, \$2.25.

THIS is said to be the book of the season, and it is creditable to the season that it is so, for it is a volume of deep and varied interest, as well as of important instruction. Without any dramatic incident or external adventure, the earnest attention of the reader is sustained by a delineation of the quiet career of a man of thought. After all, there is nothing that so concerns us, with regard to a great man, as how his greatness was reached. Mr. Mill has conducted no campaigns, explored no new countries, guided no political administrations, but through his writings he has influenced the thought of his age, in directions where thought issues in action, and his influence may thus have been deeper than if he had wielded the more obtrusive and conspicuous agencies by which men are affected. Obviously, in writing his own life, Mr. Mill did not feel that he had any greatness to take care of, and so he gives a faithful account of his development, taking the reader completely into his confidence, relating his experiences, and offering his opinions and self-criticisms with a candor and unreserve that are quite remarkable. Those who have become interested in Mr. Mill's ideas, and through them in the man, will devour the book with eager curiosity; and those who have not, can hardly fail to be incited by its perusal to the study of his works. We by no means agree with all that Mr. Mill has promulgated, and have given, in another place, the reasons for dissenting from some of his doctrines; but, while holding him as not above criticism, and as having fallen into educational error from the very greatness of his attainments, we do not hesitate to acknowledge our indebtedness to him as a great leader of liberal thought in the present age. His autobiography is valuable as a record of his own mental unfolding; but, beyond this, it has great value as a history of the rise and progress of liberalized opinion in England within the last thirty years, in the promotion of which Mr. Mill had so eminent a

share. A democrat in instinct and feeling, and holding the most radical views on grave questions of social polity and political government, Mr. Mill lived under the most compact and consolidated monarchical, aristocratic, and ecclesiastical system that the world possesses; and the history of his warfare with the ideas in which that system is embedded, while attractive as a philosophical study, has an especial interest for us, who cut loose from that order of things a century ago. Mr. Mill was never an active politician, and only tried his hand at parliamentary work for a short period, late in life; but he was much occupied with political and contemporaneous public questions, and was a virtual leader of a considerable party of men who devoted themselves to active political work.

Mr. Mill's estimates and criticisms of the thinkers of his time, and his analysis of their influence upon himself, are by no means the least interesting portions of his volume. Especially what he says of his mental indebtedness to the influence of his wife will be eagerly perused. He had already given expression to it in terms that have been thought to savor of exaggeration, but all that he had said before is here reiterated with increasing emphasis. In speaking of Carlyle, he observes: "I never presumed to judge him with any definiteness until he was interpreted to me by one greatly the superior of us both—who was more a poet than he, and more a thinker than I—whose own mind and nature included his, and infinitely more." After such a eulogy from the author of the "Logic," the question irresistibly arises, What could have been the preparation of so wonderful a mind? Mr. Mill offers his autobiography confessedly as a study in education, of which he regards himself, as he certainly was, a remarkable exemplification. But why did he forbear to utter a word in relation to the cultivation and history of that extraordinary mind which spanned and included such intellects as his own and Thomas Carlyle's? The question, moreover, will be wonderingly asked, why Mr. Mill, with all his chivalric feeling toward the opposite sex, never once mentions his mother, in the full sketch of his childhood, although his father figures prominently throughout. Per-

haps she was not a woman of intellect, and took no part in his early culture; but she had a share in his being, and, whatever may have been the qualities or character of the mother of John Stuart Mill, they should not have been left out of consideration in an account by himself of his own life.

The autobiography is written in Mr. Mill's happiest style, and deserves to be, as it undoubtedly will be, very extensively read.

SEX IN EDUCATION; OR, A FAIR CHANCE FOR THE GIRLS. By EDWARD H. CLARKE, M. D. Boston: James R. Osgood & Co., 181 pp. Price, \$1.25.

THIS little volume breaks the monotony of the woman's rights discussion, and exposes one of its current fallacies—the co-education of the sexes.

Whether or not there be sex in mind, Dr. Clarke shows that there is a great deal of it in body, and that this cannot be ignored in the work of education without entailing grave and often fatal evils upon the weaker sex. One would think that there is sufficient physiological knowledge current in the community to prevent an educational system that does not recognize and conform to the radical differences of sex; but, under pressure of a so-called reform, which starts from abstract assumptions rather than physiological data, the strong tendency is to put students of both sexes upon the same footing, regardless of all consequences. Dr. Clarke points out what some of these consequences are. He shows that there is not only a difference in powers of endurance, by which the average feminine constitution is certain to break down when brought into prolonged competition with the average male constitution, but, what is of far more importance, he shows that the feminine constitution is liable under these circumstances to a whole train of derangements and perversions that are peculiar to itself. The fact that women are designed to be mothers, while men are not, is very far from being a mere incidental circumstance that may be left out of the account in their early training. Nor can women, by declining to become mothers, escape from the peculiarities of their nature, so as to assume the career and encounter the discipline of men. The female destiny, which is to give birth to the



race is no such mere incident of humanity. It is a great thing, and its greatness is conditioned upon and attested by the serious sacrifice of other things. Woman is organized throughout her whole nature to the end of maternity, and, if treated in her youth like the opposite sex, which has not this organization, evils are liable to arise that are often numerous, lasting, and fatal. And that which reason says *must* be the result, experience says *is* the result, as Dr. Clarke's book abundantly proves. In his second chapter he makes a very clear statement of the physiological facts and principles involved in the question, and, in his third and main chapter, entitled "Chiefly Clinical," he traces the morbid consequences that have followed a false system of female education. This part of his book is full of startling facts, given in detail, that should arrest the attention of some of our headlong reformers. The book is one that ought to have a wide circulation, and to be issued in a cheaper form.

**BRITISH MARINE ALGÆ:** being a Popular Account of the Sea-weeds of Great Britain, their Collection and Preservation. Illustrated. By W. H. Grattann. London: "The Bazaar" office, 32 Wellington Street, Strand, W. C.

WHILE the collecting of algæ at the sea-side has long been a graceful and favorite amusement, and many persons have very pretty collections of them, mounted on cards and papers, or arranged in fanciful designs, very few have attempted to learn their names or to study out their structure, fructification, and the principles of their classification. Thanks to the labors of the two Agardhs, Kützing, Thuret, Harvey, Greville, and other eminent phycologists, the scientific knowledge of these plants now rests on a satisfactory and logical basis, and while the study of algæ is difficult in the extreme, there are ample results to reward the patient and careful investigator. The purpose of the little book, the title of which is given above, is to afford to amateurs and to students an easy introduction to the knowledge of algæ, and, if one may judge from the first four parts of the work, all yet received, the author has succeeded admirably in his purpose. The wonder is, that Mr. Grattann has been able to convey

so much knowledge about the subject he treats of, and yet be so sparing in the use of technical expressions.

The fact that most of the sea-weeds of the Northern Atlantic coast of the United States occur also about the British Islands, renders this book nearly as available for use here as in Great Britain. The illustrations are very neatly-prepared woodcuts, mostly on a black ground, and are inserted in the body of the work. For advanced students in American phycology the only special treatise is the "*Nereis Boreali-Americana*" of the late Dr. Harvey, of Trinity College, Dublin, a quarto with fifty colored plates, published by the Smithsonian Institution.

---

## MISCELLANY.

### Physical Conditions of Inland Seas.—

In the August number of the *Contemporary Review* is a paper of great interest by Dr. Carpenter, in which that scientist explains some curious phenomena of inland seas. It is well known that in the open ocean the depths are uniformly colder than near the surface, so that, while the surface-water in some cases approaches 80° Fahr., the temperature is near the freezing-point at depths of one or two miles. This appears to occur where the movement of water is unobstructed by inequalities of the ocean's bed. Where these are present, however, the temperature is more uniform throughout, as in the Sulu Sea, where the water is at 50° at the greatest depths, but in the contiguous but more open China Sea it is at 37° in deep soundings.

From the cause assigned, the inland seas show a uniformity of temperature as compared with the open oceans. While the surface-waters may be of equal temperature, the depths present great contrast. The Straits of Gibraltar are quite shallow, and a free interchange of waters between the Atlantic and the Mediterranean is impossible. From local causes there is frequently no current, or but a very slight one, either one way or the other. As a consequence of this, the cold waters of the deep Atlantic are prevented from flowing in, and a comparatively uniform temperature prevails in the depths of the Mediterranean.



This being the case, there is little or no circulation—the water becomes to some extent stagnant, affecting in a marked manner the development of life in it.

Dr. Carpenter was astonished to find in the Mediterranean very few evidences of life at depths greater than eighteen hundred feet. "The dredge," he says, "brought up barren mud," and, however abundant life may be around its margins, its deeper portions are *azoic*. In the cold but freely-circulating waters of the Atlantic, animals are found at nearly the greatest depths—while the dredge is often filled from soundings of one to two miles. Whence the difference? "I found," says Dr. Carpenter, "the deep waters of the Mediterranean turbid, filled with fine particles of sediment which at last make the ooze of the bottom." The presence of this floating dust, even near the surface, is proved by the blueness of the water. Turbidity is known to be unfavorable to the development of many kinds of marine life. Prof. Dana has shown that a small quantity of sediment thrown upon a portion of a reef kills the polyps on that part, and the growth and distribution of coral-reefs are largely determined by this cause. But, another reason for the absence of life at the bottom of the Mediterranean is, the deficiency of oxygen in its waters in those depths.

Deep waters from the Atlantic and Mediterranean have been boiled off, and in the gases from the first there was twenty per cent. of oxygen, from the latter only five per cent. But of carbonic acid there was from the first only thirty to forty per cent., while the latter furnished sixty per cent. Here, then, in the abundance of carbonic acid, and deficiency of oxygen, is a possible cause for the paucity of life.

But whence arises the deficiency of oxygen. Chiefly, perhaps, from the slow decomposition of organic matters, carried in by rivers and other agencies, and which may add to the turbidity referred to.

This state of things in the Mediterranean, and possibly in other inland seas, evidently arises from absence of circulation of the waters. Winds disturb the surface only, and Dr. Carpenter says there is in the Mediterranean no *thermal* circulation—or circulation which arises from inequality of

temperature. It has been said that inequality of density caused by evaporation must produce some vertical circulation of the water, but density from lowering of temperature at the surface never exceeds the density of the deeper waters, and no circulation disturbs or mixes the superimposed masses.

The oxygen from the surface can only reach the deeper waters by diffusion, hence its deficiency at considerable depths. In the Atlantic, and doubtless in all open oceans, the waters are diffused, and mixed by a wonderful system of circulation, the dynamic agencies of which are not present, or only in a modified form, in the inland basins.

The well-known and often-criticised statement of Edward Forbes, that life ceases at a depth of three hundred fathoms, is confirmed by the researches of Dr. Carpenter, in so far as it relates to inland seas, the researches of Prof. Forbes being in the *Ægean*. The error consisted in applying the same rule to the open oceans, where a different one prevails, and this appears to have been the error of others rather than of Forbes.

**Unequal Power of the Eyes.**—Probably there are but few persons possessed of equal power of vision in both eyes. This circumstance, as is observed by a writer in *Science Gossip*, will doubtless account for some people being unable to appreciate the binocular microscope. The writer in *Science Gossip* has a friend who always found difficulty in studying with a binocular, in that he could never get the two glasses to blend. In 1851 he attended the Great Exhibition in London, and there his eyes were constantly ranging from short to long distances. After he had left the Crystal Palace he felt that his eyes were very much fatigued, and was at a loss to understand the meaning of it. By this and other circumstances he discovered that there was a *focal difference* in his eyes. One eye was *far-sighted*, while the other was *near-sighted*. For reading purposes he wears a pair of spectacles in which the one glass is made for the *far* sight, while the other is a plain glass, the left eye being *near-sighted*, and consequently requiring no aid from specta-

cles with which to read. Instances are cited of persons who, while employing both eyes for ordinary vision, usually employ only one in reading. If any difference of the kind exists between the visual powers of a pair of eyes, it may be readily detected. Hold up a piece of card before one eye, so as to cut off its field of view, and then look at some object before you with the other. Then gradually bring the card before the other eye, and view the same object. If the object is seen with the same distinctness in each case, then your eyes are perfect as regards the balance of their *foci*: if not, then there is focal difference more or less decided. It would no doubt be advisable to take account of this very frequent difference of focus, in selecting a pair of spectacles.

**Natural Grafting.**—A writer in the *Gardener's Monthly* for August gives some instances of anastomosis, or natural grafting of plants, which came under his own observation. In THE POPULAR SCIENCE MONTHLY for March, 1873, we gave Goeppert's theory, accounting for the continued life and growth, in some cases, of the stumps of pine and fir trees. Goeppert's explanation of the phenomenon is, that the roots of these stumps are nourished with sap derived from the roots of trees in their neighborhood, with which they are in contact. Such roots are found deeply embedded in one another, and so consolidated as to become practically continuous. The writer in the *Gardener's Monthly*, after briefly stating these facts, describes similar phenomena which he observed last spring among the branches of two apple-trees.

In one of these the limbs so crowded one another that it was resolved to cut one away. It was accordingly sawed off; but still it did not fall. It was then found that the dismembered branch was firmly united to a limb situated beneath it. With a hatchet the writer then cut it near the point of union; but the end of the branch still lives and thrives, bearing blossoms and fruit in season. Another tree was found, but a few yards distant from the first, which exhibited the same phenomenon of natural grafting. "I had never before," continues the writer, "seen or heard of such a case in

an apple-tree, but I do not think it so difficult to account for as the condition of the coniferous trees. It is natural to suppose that the motion of the wind may occasion abrasion of the bark on the limbs of apple-trees, and thus prepare them for this natural grafting; but, in the case of roots underground, such cause for union cannot operate. In both these instances, it is worthy of remark that the trees were of the kind called American Pippin, or Grindstone." But surely there is no difficulty in conceiving of two roots from different trees growing into contact, when compressed together into a narrow space owing to the refractory nature of the soil. Under such circumstances they might rub away each other's bark at the point of contact, and establish between themselves such an exchange of living force as would constitute a life in common.

**The Quinine-Supply.**—The cultivation of the cinchona-tree in India, which was commenced in 1860, is making satisfactory progress. Near Darjeeling are two large plantations, one owned by the government, and the other by an association. The three principal varieties of the cinchona, *officinalis*, *calisaya*, and *succirubra*, were all planted at Darjeeling, with a view to find which variety would thrive best there. The *officinalis*, or gray-bark variety, failed utterly; the *calisaya*, or yellow-bark, has fairly succeeded; but the *succirubra*, or red-bark, has prospered beyond all expectation. There are now 2,500 acres under *succirubra*. A moderate estimate gives the produce of these plantations for the next three years at 200,000 lbs., calculated to produce 6,000 lbs. of quinine, and an equal amount of other valuable alkaloids.

Some years since a quinine famine appeared to be inevitable, as the cinchona-trees were fast disappearing in South America. "The drug," writes Berthold Seemann, "is almost as indispensable to mankind as air itself, and, aided by this silent agent, Europeans have been able to establish happy homes, busy factories, and flourishing colonies, in districts which, without this invaluable aid, would have simply become their graveyards. Our only wonder is, how we could ever have done without it, and what would become of us if the supply

should ever fail. And the supply does begin to fail (1863), fail rapidly. It is known that 1,200,000 lbs. of Peruvian (or cinchona) bark are annually imported into England; and it is estimated that no less than 3,000,000 lbs., and probably a much greater quantity, are consumed every year throughout the world. The demand is daily increasing, and the drain upon the forests of New Granada, Ecuador, Peru, and Bolivia, has now been going on for two centuries.

"Thus, what with the excessive and unceasing demand for bark, and the reckless manner of collecting it, large tracts of country, formerly famous for their abundant yield, are now entirely denuded of almost every trace of cinchona-vegetation."

**The Caterpillar Nuisance in Philadelphia.**—For several years the measuring-worm preyed on the leaves of the trees in Philadelphia to such an extent that, early in the summer, scarcely any foliage would be left remaining. The English sparrow was introduced to counteract the destroyer, and performed its work so effectually that after a year or two no more measuring-worms were to be seen. But now, according to the *Medical Times*, another enemy of the trees has made its appearance, the caterpillar of the *Orgyia leucostigma* moth. As long as the measuring-worm was left unmolested, the caterpillar, which comes late in the season, found the struggle for existence a sharp one, its natural provision having been previously consumed by the worm. Now, however, it finds abundance of food, and is consequently prospering and rapidly multiplying. The sparrows will not attack it, protected as it is by its hairy coat. Perhaps some other feathered exterminator can be found to destroy the tribe; but, inasmuch as the sparrow is a very stubborn and pugnacious little fellow, it is a question whether he will allow any other bird to trespass on his domain. Meanwhile, the caterpillar pest is assuming formidable proportions, as witness the following passage from our medical contemporary: "At present, very many trees in this city have again put on the familiar, woe-begone look of old, hiding their misery with the merest tatters and shreds of leaves. 'But the new-comer doesn't drop on you!' Doesn't he though?"

If he does not drop he crawls, or gets on some way or other; and the man who has felt his long hairs tickling his neck, struck for a fly, and found in his hand a bare and *burst*ed carcass, on his shirt-collar a stain, and down his back a bunch of tickling hairs, will vote the 'survival of the fittest,' in its latest form, an unmitigated nuisance."

**Eating Alcohol.**—It has been generally supposed that the alcohol formed in the primary fermentation of bread was all expelled by the process of baking. Mr. Thomas Bolas, of London, has communicated to the *Chemical News* the result of some experiments on this point. He shows that when about two ounces of ordinary bread is mixed with water and distilled, and the distillate is afterward purified, a perceptible quantity of alcohol may be obtained. He made quantitative analyses of six samples of fresh bread, obtained in so many shops in London, which gave of alcohol an average of 0.314 per cent. So that, when a man has eaten 100 pounds of fresh bread, he has consumed with it a little more than five ounces of pure alcohol.

**The Grape-vine Blight.**—M. Planchon, of the French Academy, an eminent botanist and entomologist, visited this country last summer to study the habits of the *phylloxera*, an insect which is ravaging the vineyards of France. Prof. Planchon was the first to discover that the blight of the grape-vine is the work of the *Phylloxera vastatrix*; and then Prof. Riley, State entomologist of Missouri, proved the American origin of the redoubtable ravager.

M. Planchon's investigations in this country fully corroborate Prof. Riley's observations as to the identity of the European and American insect, and as to the comparative immunity of certain American grape-vines. The Missouri entomologist's discovery of a species of *acar*us, which is the deadly enemy of the *phylloxera*, has attracted much attention abroad, and M. Planchon takes a supply of *acari* back with him to France, hoping by their aid to check the career of the destroying insect.

For five years, every remedy that imagination could suggest, under the stimulus of a reward of 20,000 francs, has been tried

in France, but hitherto without success. The latest remedy, one from which great results were expected, is sulphuret of carbon. It was held that this substance is fatal to the *phylloxera*, but perfectly harmless to the vines. As to the first point, there appears to be no reason to question the beneficial effects of the sulphuret, but not so with regard to the second, if we may put any faith in the experiments of Lecoq de Boisbaudrant. According to him, sulphuret of carbon kills the vine as well as its parasite.

**Migrations of Insects.**—The following historical facts will give an idea of the enormous magnitude sometimes attained by migrating swarms of insects. After the defeat of Poltava, while retreating through Bessarabia, Charles XII.'s army was marching through a defile, when suddenly the men and horses were brought to a halt, being blinded by a living hail precipitated from a thick cloud which intercepted the light of the sun. The coming of the locusts was heralded by a whizzing sound like that which precedes a storm of wind, and the noise of their wings and of their bodies as they clashed together was greater than the roar of breakers on the sea-shore! General Levaillant saw, at Philippeville, Algeria, a cloud of locusts twenty to twenty-five miles in length, which, when it descended to the earth, formed a layer over an inch in thickness.

Toward the close of 1864 the cotton plantations of Senegal were destroyed, and a living cloud was seen to pass over the country from morning till night: the rate at which it moved showed that it was about fifty miles long; and this was only the vanguard, for when the sun went down a still denser cloud was moving on. The English traveller, Barrow, states that in Southern Africa, in the year 1797, these insects covered the ground to the extent of two square miles, and that having been driven by the wind toward the sea, they formed a drift near the coast nearly four feet in depth and fifty miles long! After the wind changed, the stench of their putrefying carcasses was recognized at the distance of a hundred and fifty miles.

The famines produced by the voracity of these acridians are not the only evils

they cause to men and animals; a pestilential epidemic is oftentimes the result of the foul emanations from their rotting bodies. The invasions of these insects are veritable national calamities. In 1835 China was ravaged by them, and the sun and moon were obscured. Wherever they alighted the finest and richest crops were instantly devoured and the fields left bare; even the contents of the barns were to a great extent consumed by them. The people fled in alarm to the mountains. In the submerged districts, where there were no crops to devour, the locusts penetrated into the houses and destroyed the people's clothing. These ravages, which began in April, continued without interruption till the season of frost and snow.

**Animal-like Functions of Plants.**—In the Biological Section of the late meeting of the British Association, Dr. Burdon Sanderson read a paper on the electrical phenomena which accompany the contractions of the leaf of Venus's-Flytrap. It was remarked that in those structures in the higher animals which are endowed with the property of contracting when stimulated, viz., nerve and muscle, this property is associated with the existence of voltaic currents which have definite directions in the tissue. It became suspected that such was similarly true of the Sundew (*Drosera*), and Venus's-Flytrap (*Dionæa muscipula*) and some other plants. Mr. Darwin furnished the plants necessary for experiment to Dr. Sanderson in the laboratory of University College, London. The result is, that the anticipations of the existence of voltaic currents in these parts have been confirmed, particularly in the leaf of *Dionæa*. The doctor has established the fact that these currents are subject, in all respects in which they have been investigated, to the same laws as those of muscle and nerve. This may be regarded as one of the most interesting of recent biological discoveries.

**Natural Varieties.**—Nature's best efforts in the vegetable kingdom sometimes seem to be reached *per saltum*, and without any aid from man. Recently in England a first-class certificate was given by the Royal Horticultural Society for a fine variety of gooseberry,

under the name "Kerson's Seedling Gooseberry." It turns out to be no garden seedling, but a wild one originally taken from a common hedge in the neighborhood of Peterborough. In like manner, the celebrated Bess Pool apple was originally discovered in a wood near Nottingham. It is noteworthy that the famous Lawton blackberry of this country was found wild at New Rochelle, in Westchester County, New York. It may be remarked of all these, and similar seedlings, that their specific excellence cannot be propagated by seeds but only by cuttings, stolons, or grafts.

**Malformations.**—Last winter one of our pupils at New Brunswick, N. J., communicated the fact that he had purchased, the previous autumn, of a huckster-woman in Newark, a pair of young ducks, each having four wings. The woman had twelve for sale, and said that the eggs were laid by a well-formed bird; that she hatched a brood of sixteen, every one of them having four wings. The youth said that his birds used both pairs of wings in flying, that is, in moving rapidly on the surface of the pond. They did not live long. Whether this was due to any defective vitality in the birds, or to any extraneous cause, could not be learned. But we turn from these traditional facts to a catastrophe, which our own eyes have inspected, as having befallen a family of cats.

About a mile and a half from Freehold, N. J., live an intelligent family who have had for several years an annual litter of malformed cats. Several years ago a young male cat was brought from Allentown, some twenty miles distant. This cat had a deformity in one front-foot, which had six toes. It coupled with a cat of normal form and parts, and a litter of four or five was the result, all with six-toed front-feet. The she-cat became troublesome, getting into the pantry, and so was sent off. The kittens were disposed of, except one. With this the paternal cat united, and the result was four kittens, each having six toes on each fore-foot, and five on each hind-foot. This intermixing, as I understand, by this Grimalkin Turk, has gone on for some four years, and to-day, July 29th, I examined one of his daughters, some three months

old, which has *six toes* on each of the hind-feet, and *seven toes* on each of the fore-feet. The fore-feet are bifurcated; that is, they have, as it were, each two paws to one foot, the outer paw of each foot being much the larger, and having four toes; and the inner, or smaller paw, on each foot, having three toes. This kitten was one of a litter of four, all malformed precisely alike. On some points I could not get the exact information desired. But I should think that the vitality of these cats is becoming less and less, as they do not become common. To me it seems astounding when I attempt to conceive of the physical equation which enters into this erratic conception—the minuteness of the abnormal material which, plus the normal substance as imparted by the spermatozoon, gives the initial impulse to a result so eccentric. If, as Goethe declared, "it is in her monstrosities that Nature reveals to us her secrets," one would like to know something of the mode and motive of such a distribution of the life-force. During our inspection of Miss Tabbie it was all very well so long as we stroked her back with one hand. She purred, as expressive of true feline luxuriousness; and, what is not common, she even licked the other hand as indicating affection. But, when we meddled with her extremities, she evidently regarded it as taking personal liberties with unpleasant peculiarities; and instantly rewarded our duplicity by investing in our hand the seven talons concealed in that duplex napkin.—SAMUEL LOCKWOOD, in *American Naturalist*.

---

## NOTES.

PROF. EATON, of Yale College, kindly calls attention to an inaccuracy in the sketch of Dr. J. D. Hooker published in *THE POPULAR SCIENCE MONTHLY* for December, 1873. It is there stated that Dr. Hooker was an only son. Prof. Eaton writes: "In 'Filices Exoticæ,' p. 36, Sir W. J. Hooker refers to the kindness formerly shown by Dr. McFadyen, of Kingston, Jamaica, 'to a beloved son who fell a sacrifice to yellow fever while under his hospitable roof.' The widow of this son, Mrs. William Hooker, is still living at Glasgow, and I saw her several times at Dr. Hooker's house in Kew, in 1866." Prof. Eaton adds the interesting fact that the grandfather of Dr. Hooker on his mother's side, Dawson Turner, Esq.,



was an excellent botanist, and the author of "Spicilegium Muscologiae Hibernicae," a treatise on Irish mosses, published at Yarmouth in 1804. The earliest botanical writings of the elder Hooker were, to a great extent, also upon mosses.

In the year ending April 1, 1873, there were bred in the Central Park Menagerie, 2 lions, 2 pumas, 1 leopard, 1 spotted hyena (the first born in America), 1 camel, and 1 Cape buffalo. The total number of animals in the menagerie is now: quadrupeds, 199; birds, 347; reptiles, 35. The additions during the year numbered 48, viz., 25 mammals, 21 birds, and 2 reptiles.

The Minnesota State Geologist is authority for the statement that there is enough iron-ore in the neighborhood of the Black River Falls, in that State, to supply the whole demand of the Union for the next ten centuries.

The following extract from a letter recently received in London, and sent by Dr. Beke to the *Times*, gives the latest information regarding the whereabouts and condition of Dr. Livingstone:

"BOENA, August 12, 1873.

"I am proceeding, to-day or to-morrow, to Munuco, Upper Congo. In a few days we expect there the Livingstone Expedition, which cannot proceed from St. Salvador. Livingstone himself is a prisoner in a town, twenty days from here, but is entirely without means to pay his ransom. Assistance has, however, been sent to him, and he may be here in a month or so."

In the department of the Vienna Exposition devoted to medical and surgical instruments and preparations, certain anatomical specimens exhibited by Dr. Marini, of Naples, have attracted special attention. He has invented processes for the preservation of bodies, both in the leathery or tanned state, and in the natural condition of the tissues. In the latter case, the tissues preserve their natural softness and even their transparency. Among the specimens exhibited, was a foot which had been prepared in 1864. On making an incision into this, the underlying tissues appeared to be as fresh as in a cadaver one day old. The tendons, ligaments, and fatty tissue, preserved all their usual characters, the muscles alone being in a slightly inferior state of preservation. The same solutions which are used for embalming bodies may be employed in the treatment of malignant ulcers. For this purpose they are largely diluted. Dr. Marini has made experiments in the Naples Hospital, with a view to determine the value of his solutions in such cases, and the report of the surgeons as to the efficacy of the treatment is very favorable.

Dr. F. GRACE-CALVERT, the eminent chemist, died, Friday, October 24th, aged fifty-nine. He received his early education in France, and received the appointment as assistant chemist at the Gobelin tapestry-works, under his master, Chevreul. In 1846 he was appointed Professor of Chemistry to the Manchester Royal Institution, a post which he held down to his death. As an analytical chemist his renown was worldwide.

DURING the past summer, two ship-loads of oysters were imported into England from Virginia for transplantation. If this venture proves a success, eight or ten steamers will be sent from England to Hampton Roads for oysters next season.

ACCORDING to statistics collected by Dr. T. Harrington Tuke, the number of lunatics in England increased during the ten years ending June, 1873, from 1.86 per thousand of the population to 2.58. Dr. Tuke is inclined to attribute this increase to the advance in wages, which allows the laboring class enlarged means of undue indulgence.

THE trials at Williamshaven with the new Hertz torpedo gave the most surprising results, the torpedoes disposing of the objects attached with the utmost punctuality and in a strikingly summary manner. Their construction is as yet a secret; but there is no doubt that the German navy is now in possession of a most powerful and destructive weapon which will not only effectually protect the coasts of the empire, but will also enable the government to employ all its resources in building ships for aggressive purposes.

THE Peruvian Amazons Exploring Commission lately issued a report, from which it appears that malarious fever prevails on both banks of the mighty river, causing a large mortality among the native population. Adults and children are given to the filthy habit of geophagy or clay-eating, a practice productive of innumerable physical evils. It is common to find on the Amazons children of three years of age smoking, and not averse to rum.

PROF. PALMIERI, director of the Observatory of Mount Vesuvius, has constructed for the Empress of Russia a metallic thermometer, which gives a signal at every appreciable change of temperature. The apparatus is so sensitive that the indicator is almost always moving. When the variations of temperature reach a certain degree, little bells begin to ring, and notice is thus given of the rising or falling of the mercury. The instrument also marks the highest and lowest degrees of temperature which have taken place during a certain period.







**RICHARD ANTHONY PROCTOR.**

THE  
POPULAR SCIENCE  
MONTHLY.

---

FEBRUARY, 1874.

---

THE CHROMOSPHERE AND SOLAR PROMINENCES.

BY C. A. YOUNG,

PROFESSOR OF ASTRONOMY IN DARTMOUTH COLLEGE.

WHAT we see of the sun under ordinary circumstances is but a fraction of his total bulk. While by far the greater portion of the solar mass is included within the photosphere, the blazing cloud-layer which seems to form the sun's true surface, and is the principal source of his light and heat, yet the larger portion of his volume lies without, and constitutes an atmosphere whose diameter is at least double, and its bulk therefore sevenfold that of the central globe.

Atmosphere, however, is hardly the proper term; for this outer envelope, though gaseous in the main, is not spherical, but has an outline exceedingly irregular and variable. It seems to be made up not of overlying strata of different density, but rather of flames, beams, and streamers, as transient and unstable as those of our own aurora borealis. It is divided into two portions, separated by a boundary as definite, though not so regular, as that which parts them both from the photosphere. The outer and far more extensive portion, which in texture and rarity seems to resemble the tails of comets, and may almost, without exaggeration, be likened to "the stuff that dreams are made of," is known as the "coronal atmosphere," since to it is chiefly due the "corona" or glory which surrounds the darkened sun during an eclipse, and constitutes the most impressive feature of the occasion.

At its base, and in contact with the photosphere, is what resembles a sheet of scarlet fire. The appearance, which probably indicates a fact, is as if countless jets of heated gas were issuing through vents and spiracles over the whole surface, thus clothing it with flame which heaves and tosses like the blaze of a conflagration.

This is the "chromosphere" (or chromatosphere, if one is fastidious as to the proper formation of a Greek derivative), a name first proposed by Frankland and Lockyer in 1869, and intended to signify

“color-sphere,” in allusion to the vivid redness of the stratum caused by the predominance of hydrogen in these flames and clouds.

Here and there masses of this hydrogen mixed with other substances rise to a great height, ascending far above the general level into the coronal regions, where they float like clouds, or are torn to pieces by contending currents. These cloud-masses are known as solar “prominences,” or “protuberances,” a non-committal sort of appellation applied in 1842, when they first attracted any considerable attention, and while it was a warmly-disputed question whether they were solar, lunar, phenomena of our own atmosphere, or even mere optical illusions. It is unfortunate that no more appropriate and graphic name has yet been found for objects of such wonderful beauty and interest.

Until recently, the solar atmosphere could be seen only when the sun itself was hidden by the moon, a few minutes in a century. Now, however, the spectroscope has brought the chromosphere and the prominences within the range of daily observation, so that they can be studied with nearly the same facility as the spots and faculæ, and a fresh field of great interest and importance is thus opened to science. But the corona as yet defies the new method, and can be seen only during the fleeting moments of a solar eclipse.

It seems hardly possible that the ancients should have failed to notice, even with the naked eye, in some one of the many eclipses on record, the presence of blazing star-like objects around the edge of the moon, but we find no mention of any thing of the kind, although the corona is described as we see it now. On this ground some have surmised that the sun has really undergone a change in modern times, and that the chromosphere and prominences are a new development in the solar history. But such mere negative evidence is altogether insufficient as a foundation for so important a conclusion.

The earliest recorded observation of the prominences is probably that of Vassenius, a Swedish astronomer, who, during the total eclipse of 1733, noticed three or four small pinkish clouds, entirely detached from the limb of the moon, and, as he supposed, floating in the lunar atmosphere. At that time this was the most natural interpretation of the appearance, since the fact that the moon is without atmosphere was not yet ascertained.

The Spanish admiral, Don Ulloa, in his account of the eclipse of 1778, describes a point of red light which made its appearance on the western limb of the moon about a minute and a quarter before the emergence of the sun. At first small and faint, it grew brighter and brighter until extinguished by the returning sunlight. He supposed that the phenomenon was caused by a hole or fissure in the body of the moon; but, with our present knowledge there can be no doubt that it was simply a prominence gradually uncovered by her motion.

The chromosphere seems to have been seen even earlier than the

prominences: thus Captain Stannyan, in a report on the eclipse of 1706, observed by him at Berne, noticed that the emersion of the sun was preceded by a blood-red streak of light, visible for six or seven seconds upon the western limb. Halley and Louville saw the same thing in 1715. Halley says that two or three seconds before the emersion a long and very narrow streak of a dusky but strong red light seemed to color the dark edge of the moon on the western edge where the sun was about to reappear. Louville's account agrees substantially, and he further describes the precautions he used to satisfy himself that the phenomenon was no mere optical illusion, nor due to any imperfection of his telescope.

In eclipses that followed that of 1733, the chromosphere and prominences seem to have attracted but little attention, even if they were observed at all. Something of the sort appears to have been noticed by Ferrers in 1806, but the main interest of his observation lay in a different direction.

In July, 1842, a great eclipse occurred, and the shadow of the moon described a wide belt running across Southern France, Northern Italy, and a portion of Austria. The eclipse was carefully observed by many of the most noted astronomers of the world, and so completely had previous observations of the kind been forgotten, that the prominences, which appeared then with great brilliance, were regarded with extreme surprise, and became objects of warm discussion, not only as to their cause and location, but even as to their very existence. Some thought them mountains upon the sun, some that they were solar flames, and others, clouds floating in the sun's atmosphere. Others referred them to the moon, and yet others claimed that they were mere optical illusions. At the eclipse of 1851 (in Sweden and Norway), similar observations were repeated, and, as a result of the discussions and comparison of observations which followed, astronomers generally became satisfied that the prominences are real phenomena of the solar atmosphere, in many respects analogous to our terrestrial clouds; and several came more or less confidently to the conclusion, now known to be true (*see* Grant's "History of Physical Astronomy"), that the sun is entirely surrounded with a continuous stratum of the same substance. Many, however, remained unconvinced: Faye, for instance, still asserted them to be mere optical illusions, or mirages.

In the eclipse of 1860, photography was for the first time employed on such an occasion with any thing like success. The results of Secchi and De La Rue removed all remaining doubts as to the real existence and solar character of the objects in question, by exhibiting them upon their plates gradually covered on one side and uncovered on the other side of the sun by the outward progress of the moon.

Secchi thus sums up his conclusions, which have been justified in almost all their details by later observations; they require few and slight corrections:

1. The prominences are not mere optical illusions; they are real phenomena pertaining to the sun. . . .

2. The prominences are collections of luminous matter of great brilliance, and possessing remarkable photographic activity. This activity is so great that many of them, which are visible in our photographs, could not be seen directly even with good instruments.

3. Some protuberances float entirely free in the solar atmosphere like clouds. If they are variable in form, their changes are so gradual as to be insensible in the space of ten minutes. (Generally, but by no means always, true.)

4. Besides the isolated and conspicuous protuberances there is also a layer of the same luminous substance which surrounds the whole sun, and out of which the protuberances rise above the general level of the solar surface. . . .

5. The number of the protuberances is indefinitely great. In direct observation through the telescope the sun appeared surrounded with flames too numerous to count. . . .

6. The height of the protuberances is very great, especially when we take account of the portion hidden by the moon. One of them had a height of at least three minutes, which indicates a real altitude of more than ten times the earth's diameter. . . .

But their nature still remained a mystery; and no one could well be blamed for thinking it must always remain so to some degree. At that time it could hardly be hoped that we should ever be able to ascertain their chemical constitution, and measure the velocities of their motions. And yet this has been done. Before the great Indian eclipse of August 18, 1868, the spectroscope had been invented (it was, indeed, already in its infancy in 1860), and applied to astronomical research with the most astonishing and important results.

Every one is more or less familiar with the story of this eclipse. Herschel, Tennant, Pogson, Rayet, and Janssen, all made substantially the same report. They found the spectrum of the prominences observed to consist of bright lines, and conspicuous among them were the lines of hydrogen. There were some serious discrepancies, indeed, among their observations, not only as to the number of the bright lines seen, which is not to be wondered at, but as to their position. Thus, Rayet (who saw more lines than any other) identified the red line observed with B instead of C; and all the observers mistook the yellow line they saw for that of sodium.

Still, their observations, taken together, completely demonstrated the fact that the prominences are enormous masses of highly-heated gaseous matter, and that hydrogen is a main constituent.

Janssen went further. The lines he saw during the eclipse were so brilliant that he felt sure he could see them again in the full sunlight. He was prevented by clouds from trying the experiment the same afternoon, after the close of the eclipse; but the next morning



the sun rose unobscured, and, as soon as he had completed the necessary adjustments, and directed his instrument to the portion of the sun's limb where the day before the most brilliant prominence appeared, the same lines came out again, clear and bright; and now, of course, there was no difficulty in determining at leisure, and with almost absolute accuracy, their position in the spectrum. He immediately confirmed his first conclusion, that hydrogen is the most conspicuous component of the prominences, but found that the yellow line must be referred to some different element than sodium, being somewhat more refrangible than the D lines.

He found also that, by slightly moving his telescope and causing the image of the sun's limb to take different positions with reference to the slit of his spectroscope, he could even trace out the form and measure the dimensions of the prominences; and he remained at his station for several days, engaged in these novel and exceedingly interesting observations.

Of course, he immediately sent home a report of his eclipse-work, and of his new discovery, but, as his station at Guntoor, in Eastern India, was farther from mail communication with Europe than those upon the western coast of the peninsula, his letter did not reach France until some week or two after the accounts of the other observers; when it did arrive, it came to Paris, in company with a communication from Mr. Lockyer, announcing the same discovery, made independently, and even more creditably, since with Mr. Lockyer it was not suggested by any thing he had seen, but was thought out from fundamental principles.

Nearly two years previously the idea had occurred to him (and, indeed, to others also, though he was the first to publish it), that if the protuberances are gaseous, so as to give a spectrum of bright lines, those lines ought to be visible in a spectroscope of sufficient power, even in broad daylight. The principle is simply this:

Under ordinary circumstances the protuberances are invisible, for the same reason as the stars, in the daytime: they are hidden by the intense light reflected from the particles of our own atmosphere near the sun's place in the sky, and, if we could only sufficiently weaken this aerial illumination, without at the same time weakening *their* light, the end would be gained. And the spectroscope accomplishes precisely this very thing. Since the air-light is reflected sunshine, it of course presents the same spectrum as sunlight, a continuous band of color crossed by dark lines. Now, this sort of spectrum is greatly weakened by every increase of dispersive power, because the light is spread out into a longer ribbon and made to cover a more extended area. On the other hand, a spectrum of bright lines undergoes no such weakening by an increase in the dispersive power of the spectroscope. The bright lines are only more widely separated—not in the least diffused or shorn of their brightness. If, then, the image of the sun, formed by

a telescope, be examined with a spectroscope, one might hope to see at the edge of the disk the bright lines belonging to the spectrum of the prominences, in case they are really gaseous.

Mr. Lockyer and Mr. Huggins both tried the experiment as early as 1867, but without success; partly because their instruments had not sufficient power to bring out the lines conspicuously, but more because they did not know whereabouts in the spectrum to look for them, and were not even sure of their existence. At any rate, as soon as the discovery was announced, Mr. Huggins immediately saw the lines without difficulty, with the same instrument which had failed to show them to him before. It is a fact, too often forgotten, that to perceive a thing known to exist does not require one-half the instrumental power or acuteness of sense as to discover it.

Mr. Lockyer, immediately after his suggestion was published, had set about procuring a suitable instrument, and was assisted by a grant from the treasury of the Royal Society. After a long delay, consequent in part upon the death of the optician who had first undertaken its construction, and partly due to other causes, he received the new spectroscope just as the report of Herschel's and Tennant's observations reached England. Hastily adjusting the instrument, not yet entirely completed, he at once applied it to his telescope, and without difficulty found the lines, and verified their position. He immediately also discovered them to be visible around the whole circumference of the sun, and consequently that the protuberances are mere extensions of a continuous solar envelope, to which, as mentioned above, was given the name of Chromosphere. (He does not seem to have been aware of the earlier and similar conclusions of Arago, Grant, Secchi, and others.) He at once communicated his results to the Royal Society, and also to the French Academy of Sciences, and, by one of the curious coincidences which so frequently occur, his letter and Janssen's were read at the same meeting, and within a few minutes of each other.

The discovery excited the greatest enthusiasm, and in 1872 the French Government struck a gold medal in honor of the two astronomers, bearing their united effigies.

It immediately occurred to several observers, Janssen, Lockyer, Zöllner, and others, that by giving a rapid motion of vibration or rotation to the slit of the spectroscope it would be possible to perceive the whole contour and detail of a protuberance at once, but it seems to have been reserved for Mr. Huggins to be the first to show practically that a still simpler device would answer the same purpose. With a spectroscope of sufficient dispersive power it is only necessary to widen the slit of the instrument by the proper adjusting screw. As the slit is widened, more and more of the protuberance becomes visible, and if not too large the whole can be seen at once: with the widening of the slit, however, the brightness of the background increases, so that the finer details of the object are less clearly seen, and a limit

is soon reached beyond which further widening is disadvantageous. The higher the dispersive power of the spectroscope the wider the slit that can be used, and the larger the protuberance that can be examined as a whole.

FIG. 1.

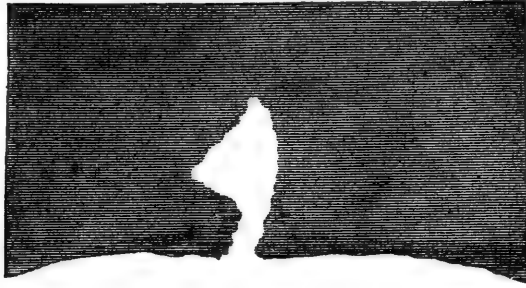

HUGGINS'S FIRST OBSERVATION OF A PROMINENCE IN FULL SUNSHINE.

Mr. Huggins's first successful observation of the form of a solar protuberance was made on February 13, 1869. Fig. 1, copied from the Proceedings of the Royal Society, presents his delineation of what he saw. As his instrument had only the dispersive power of two prisms, and included in its field of view a large portion of the spectrum at once, he found it necessary to supplement its powers by using a red glass to cut off stray light of other colors, and by inserting a diaphragm at the focus of the small telescope of the spectroscope to limit the field of view to the portion of the spectrum immediately adjoining the C line. With the instruments now in use, these precautions are seldom necessary.

FIG. 2.

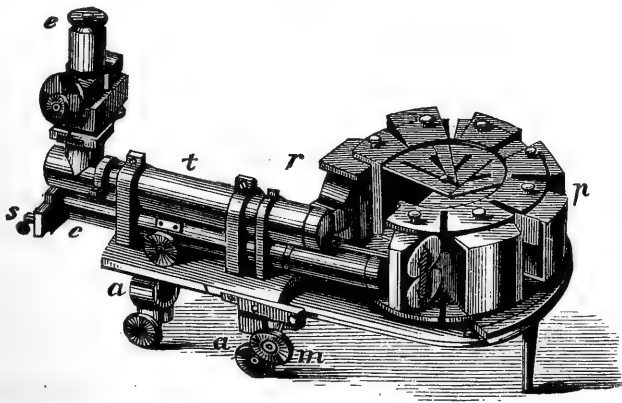

SPECTROSCOPE, WITH TRAIN OF PRISMS.

It may be noticed, in passing, that Mr. Huggins had previously (and has subsequently) made many experiments with different absorbing media, in hopes of finding some substance which, by cutting off all light of other color than that emitted by the prominences, should render them visible in the telescope; thus far, however, without success.

The spectroscopes used by different astronomers for observations of this sort differ greatly in form and power. Fig. 2 represents the

one employed at the Shattuck Observatory of Dartmouth College, and most of our American observatories are supplied with instruments similarly arranged. The light passes from the collimator *c*, through the train of prisms *p*, near their bases, and, by two reflections in a rectangular prism, *r*, is transferred to the upper story, so to speak, of the prism-train, and made to return to the telescope *t*, finally reaching the eye at *e*. It thus twice traverses a train of six prisms, and the dispersive power of the instrument is twelve times as great as it would be with only one prism. The diameter of the collimator is a little less than an inch, and its length 10 inches. The whole instrument, powerful as it is, only weighs about 14 pounds, and occupies a space of about 15 in.  $\times$  6 in.  $\times$  5 in. It is also *automatic*, i. e., the tangent screw *m* keeps the train of prisms adjusted to their position of minimum deviation by the same movement which brings the different portions of the spectrum to the centre of the field of view.

The spectroscope is attached to the equatorial telescope, to which it belongs, by means of the clamping rings *a*, *a*. These slide upon a stout metal rod, firmly fastened to the telescope in such a way that the slit *s*, of the instrument, can be placed exactly at the focus of the object-glass, where the image of the sun is formed.<sup>1</sup>

The telescope is directed so that the solar image shall fall with that portion of its limb which is to be examined just tangent to the opened slit, as in Fig. 3, which represents the slit-plate of the spectroscope of its actual size, with the image of the sun in position for observation just touching the rectangular opening formed on widening the slit by its adjusting screw.

FIG. 3.

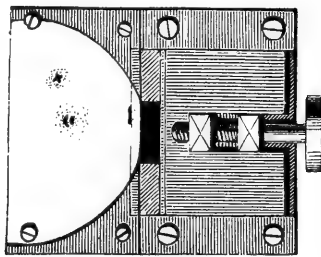

OPENED SLIT OF THE SPECTROSCOPE.

If, now, a prominence exists at this part of the sun's limb (as would probably be the case, considering the proximity of the spot shown in Fig. 3), and if the spectroscope itself is so adjusted that the C line falls in the centre of the field of view, then, on looking into the eye-piece, one will see something much like Fig. 4. The red portion of the

<sup>1</sup> The writer has recently found that a so-called diffraction-grating may take the place of the train of prisms in spectroscopes designed for simply viewing the prominences. With a grating ruled upon speculum metal, having 6,480 lines to the inch (for which he is indebted to the skill and kindness of Mr. Rutherford), he is able to observe the forms and motions of these objects nearly as well as with the spectroscope described in the text.

spectrum will stretch athwart the field of view like a scarlet ribbon, with a darkish band across it, and in that band will appear the prominences, like scarlet clouds; so like our own terrestrial clouds, indeed, in form and texture, that the resemblance is quite startling: one might almost think he was looking out through a partly-opened door upon a sunset sky, except that there is no variety or contrast of color; all the cloudlets are of the same pure scarlet hue. Along the edge of the opening is seen the chromosphere, more brilliant than the clouds which rise from it or float above it, and for the most part made up of minute tongues and filaments.

FIG. 4.

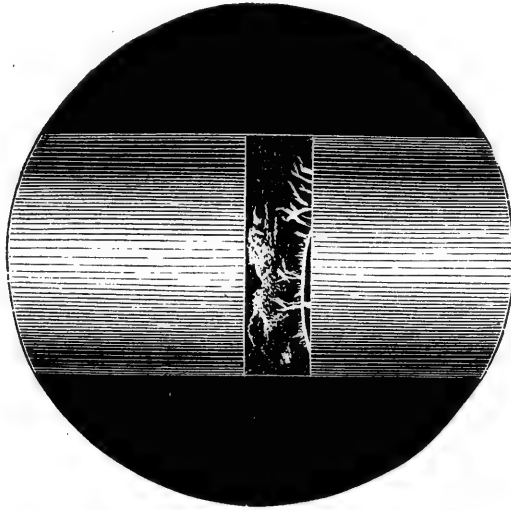

SPECTROSCOPIC ASPECT OF A PROMINENCE.

If the spectroscope is adjusted upon the F line, instead of C, then a similar image of the prominences and chromosphere is seen, only blue instead of scarlet; usually, however, this blue image is somewhat less perfect in its details and definition, and is therefore less used for observation. Similar effects are obtained by means of the yellow line near D, and the violet line near G. By setting the spectroscope upon this latter line and attaching a small camera to the eye-piece, it is even possible to photograph a bright protuberance; but the light is so feeble, the image so small, the time of exposure needed so long, and the requisite accuracy of motion in the clock-work which drives the telescope so difficult of attainment, that thus far no pictures of any real value have been obtained in this manner.

Prof. Winlock and Mr. Lockyer have attempted, by using, instead of the ordinary slit, an annular opening, to obtain a view of the whole circumference of the sun at once, and have partially succeeded. Undoubtedly, with a spectroscope of sufficient power, and adjustments delicate enough, the thing can be done; but as yet no very satisfactory results appear to have been reached. We are still obliged to examine the circumference of the sun piecemeal, so to speak, read-

justing the instrument at each point, to make the slit tangential to the limb.

The number of protuberances of considerable magnitude (exceeding 10,000 miles in altitude), visible at any one time on the circumference of the sun, is never very great, rarely reaching twenty-five or thirty; perhaps during the past few years it would most commonly lie between ten and twenty. At present, as the number of the spots decreases, the number of the prominences seems also to be diminishing, and within a few months there have been occasions when a careful search revealed only three or four.

Their distribution on the sun's surface is in some respects similar to that of the spots, but with important differences. The spots are confined within  $40^\circ$  of the sun's equator, being most numerous at a solar latitude of about  $20^\circ$  on each hemisphere. Now, the protuberances are most numerous precisely where the spots are most abundant, but they do not disappear at a latitude of  $40^\circ$ ; they are found even at the poles, and from the latitude of  $60^\circ$  actually increase in number to a latitude of about  $75^\circ$ .

FIG. 5.

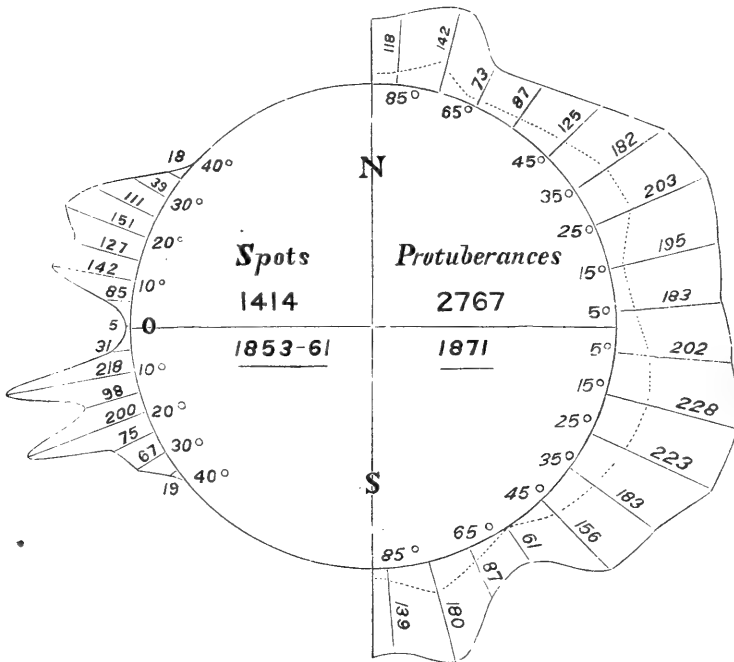

RELATIVE FREQUENCY OF PROTUBERANCES AND SUN-SPOTS.

The annexed diagram, Fig. 5, represents the relative frequency of the protuberances and spots on the different portions of the solar surface. On the left side is given the result of Carrington's observation of 1,414 spots between 1853 and 1861, and on the right the result of Secchi's observations of 2,767<sup>1</sup> protuberances in 1871. The length of

<sup>1</sup> The 2,767 prominences are not all different ones. If any of the prominences observed on one day remained visible the next, they were recorded afresh; and, as a promi-



each radial line represents the number of spots or protuberances observed at each particular latitude on a scale of a quarter of an inch to the hundred; for example, Secchi gives 228 protuberances as the number observed during the period of his work between  $10^\circ$  and  $20^\circ$  of south latitude, and the corresponding line drawn at  $15^\circ$  south, on the left-hand side of the figure, is therefore made  $\frac{228}{400}$  or .57 of an inch long. The other lines are laid off in the same way, and thus the irregular curve drawn through their extremities represents to the eye the relative frequency of these phenomena in the different solar latitudes. The dotted line on the right-hand side represents in the same manner and on the same scale the distribution of the larger protuberances, having an altitude of more than 1', or 27,000 miles.

A mere inspection of the diagram shows at once that, while the prominences may, and in fact often do, have a close connection with the spots, they are entirely independent phenomena.

A careful study of the subject shows that they are much more closely related to the faculæ. In many cases at least, faculæ, when followed to the limb of the sun, have been found to be surrounded by prominences, and there is reason to suppose that the fact is a general one. The spots, on the other hand, when they reach the border of the sun's image, are commonly *surrounded* by prominences more or less completely, but seldom overlaid by them. Indeed, Respighi asserts (and the most careful observations we have been able to make confirm his statement) that as a general rule the chromosphere is considerably depressed immediately over a spot. Secchi, however, denies this.

The protuberances differ greatly in magnitude. The average depth of the chromosphere is not far from  $10''$  or  $12''$ , or about 5,000 or 6,000 miles, and it is not, therefore, customary to note as a prominence any cloud with an elevation of less than  $15''$  or  $20''$ —7,000 to 9,000 miles. Of the 2,767 already quoted, 1,964 attained an altitude of  $40''$ , or 18,000 miles, and it is worthy of notice that the smaller ones are so few, only about one-third of the whole: 751, or nearly one-fourth of the whole, reached a height of over 1', or 28,000 miles; the precise number which reached greater elevations is not mentioned, but several exceeded 3', or 84,000 miles. There are numerous instances on record, by different observers, of protuberances exceeding 100,000 miles, and a single instance, observed by the writer, in which the enormous altitude of  $7' 49''$ , or 211,000 miles, was attained.

In their form and structure the protuberances differ as widely as in their magnitude. Two principal classes are recognized by all observers, the *quiescent, cloud-formed*, or hydrogenous, and the *eruptive* or metallic. By Secchi these are each further subdivided into several

nence near the pole would be carried but slowly out of sight by the sun's rotation, it is thus easy to see how the number of prominences recorded in the polar regions is so large, notwithstanding the smaller area of each zone of  $5^\circ$  width, as compared with a similar zone near the equator.

## ERUPTIVE PROMINENCES.

Three figures, of the same prominence,  
seen July 25, 1872.

FIG. 6.

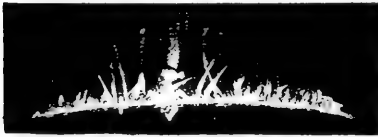

AS SEEN AT 2.15 P. M.

FIG. 9.



SPIKES.

FIG. 7.

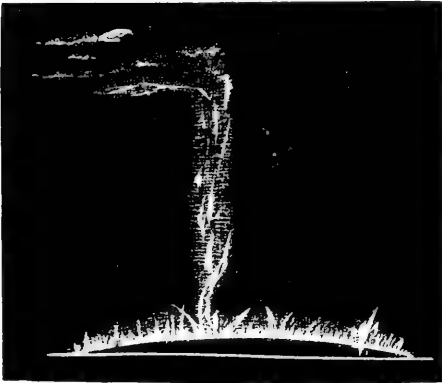

AS SEEN AT 2.45 P. M.

FIG. 10.



SHEAF AND VOLUTES.

FIG. 8.

AS SEEN AT 3.30 P. M.  
100,000 miles to the inch.

FIG. 11.

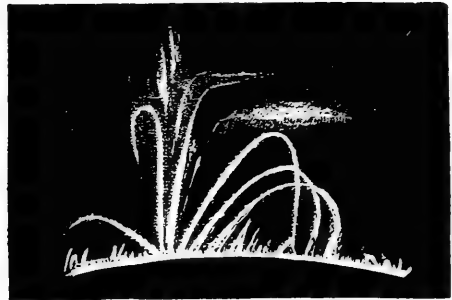

JETS.

sub-classes or varieties, between which, however, it is not always easy to maintain the distinctions.

The quiescent prominences in form and texture resemble, with almost perfect exactness, our terrestrial clouds, and differ among themselves as much and in the same manner. The familiar cirrus and stratus types are very common, the former especially, while the cumulus and cumulo-stratus are less frequent. The protuberances of this class are often of enormous magnitude, especially in their horizontal extent (but the highest elevations are attained by those of the eruptive order), and are comparatively permanent, remaining often for hours and days without serious change; near the poles they sometimes persist through a whole solar revolution of twenty-seven days.

Sometimes they appear to lie upon the limb of the sun like a bank of clouds in the horizon; probably because they are so far from the edge of the disk that only their upper portions are in sight. When seen in their full extent they are ordinarily connected to the underlying chromosphere by slender columns, which are usually smallest at the base, and appear often to be made up of separate filaments closely intertwined, and expanding upward. Sometimes the whole under surface is fringed with down-hanging filaments, which remind one of a summer shower falling from a heavy thunder-cloud. Sometimes they float entirely free from the chromosphere; indeed, as a general rule, the layer clouds are attended by detached cloudlets for the most part horizontal in their arrangement.

The figures give an idea of some of the general appearances of this class of prominences, but their delicate, filmy beauty can be adequately rendered only by a far more elaborate style of engraving.

Their spectrum is usually very simple, consisting of the four lines of hydrogen and the orange  $D^{\delta}$ —hence the appellation hydrogenous. Occasionally the sodium and magnesium lines also appear, and that even near the summit of the clouds; and this phenomenon was so much more frequently observed in the clear atmosphere of Sherman as to suggest that, if the power of our spectroscopes were sufficiently increased, it would cease to be unusual.

The genesis of this sort of prominence is problematical. They have been commonly looked upon as the *débris* and relics of eruptions, consisting of gases which have been ejected from beneath the solar surface, and then abandoned to the action of the currents of the sun's upper atmosphere. But near the poles of the sun distinctively eruptive prominences never appear, and there is no evidence of aërial currents which would transport to those regions matters ejected nearer the sun's equator. Indeed, the whole appearance of these objects indicates that they originate where we see them. Possibly, although in the polar regions there are no violent eruptions, there yet may be a quiet outpouring of heated hydrogen sufficient to account for their production—an outrush issuing through the smaller pores of the solar surface, which abound near the poles as well as elsewhere.

But Secchi reports an observation (not yet, however, confirmed by other spectroscopists, so far as we know) which, if correct, puts a very different face upon the matter. He has seen isolated cloudlets form and grow spontaneously without any perceptible connection with the chromosphere or other masses of hydrogen, just as in our own atmosphere clouds form from aqueous vapor, already present in the air, but invisible until some local cooling or change of pressure causes its condensation. Granting the correctness of the observation, these prominences are, therefore, formed by some local heating or other luminous excitement of hydrogen already present, and not by any transportation and aggregation of materials from a distance. The

## QUIESCENT PROMINENCES.

Scale, 75,000 miles to the inch.

FIG. 12.



CLOUDS.

FIG. 15.

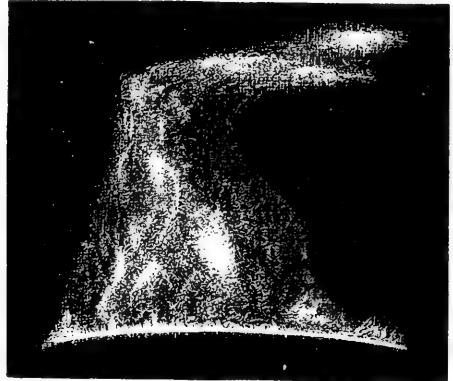

DIFFUSE.

FIG. 13.

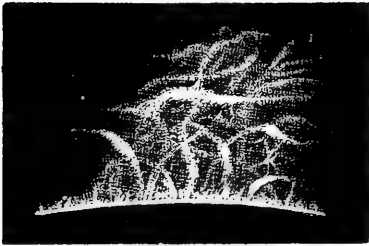

FILAMENTARY.

FIG. 16.

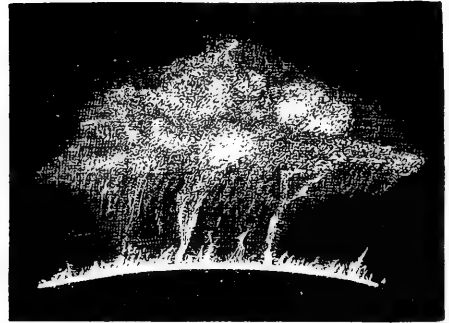

STEMMED.

FIG. 14.

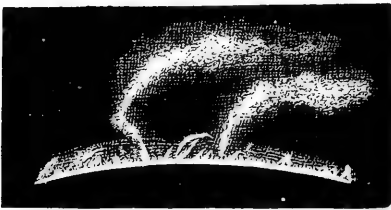

PLUMES.

FIG. 17.



HORNS.

precise nature of the action which produces this effect it would not be possible to assign at present; but it is worthy of note that the observations of the eclipse of 1871, by Lockyer and others, rather favor this view, by showing that hydrogen, in a feebly luminous condition, is found all around the sun, and—at a very great altitude—far above the ordinary range of prominences.

The eruptive prominences are very different, consisting usually of brilliant spikes or jets, which change their form and brightness very rapidly. For the most part they attain altitudes of not more than 20,000 or 30,000 miles, but occasionally they rise far higher than even

the largest of the clouds of the preceding class. Their spectrum is very complicated, especially near their base, and often filled with bright lines, those of sodium, magnesium, barium, iron, and titanium, being especially conspicuous, while calcium, chromium, manganese, and probably sulphur, are by no means rare, and for this reason Secchi calls them *metallic* prominences.

They usually appear in the immediate neighborhood of a spot, never occurring very near the solar poles. Their form and appearance change with great rapidity, so that the motion can almost be seen with the eye—an interval of fifteen or twenty minutes being often sufficient to transform, quite beyond recognition, a mass of these flames 50,000 miles high, and sometimes embracing the whole period of their complete development or disappearance. Sometimes they consist of pointed rays, diverging in all directions, like hedgehog spines. Sometimes they look like flames; sometimes like sheaves of grain; sometimes like whirling water-spouts, capped with a great cloud; occasionally they present most exactly the appearance of jets of liquid fire, rising and falling in graceful parabolas; frequently they carry on their edges spirals like the volutes of an Ionic column; and continually they detach filaments which rise to a great elevation, gradually expanding and growing fainter as they ascend, until the eye loses them. Our figures present some of the more common and typical forms, and illustrate their rapidity of change, but there is no end to the number of curious and interesting appearances which they exhibit under varying circumstances.

The velocity of the motions *often* exceeds 100 miles a second, and sometimes, though very rarely, reaches 200 miles. That we have to do with actual motions, and not with mere change of place of a luminous form, is rendered certain by the fact that the lines of the spectrum are often displaced and distorted in a manner to indicate that some of the cloud-masses are moving either toward or from the earth (and, of course, tangential to the solar surface) with similar swiftness.

When we come to inquire what forces impart such a velocity, the subject becomes difficult. If we could admit that the surface of the sun is solid, or even liquid, as Zöllner thinks, then it would be easy to understand the phenomena as eruptions, analogous to those of volcanoes on the earth, though on the solar scale. But it is next to certain that the sun is mainly gaseous, and that its luminous surface or photosphere is a sheet of incandescent clouds, like those of the earth, except that water-droplets are replaced by droplets of the metals; and it is difficult to see how such a shell could exert sufficient confining power upon the imprisoned gases to explain such tremendous velocity in the ejected matter.

Possibly the difficulty may be met by taking account of the enormous amount of condensation which must be going on within the photosphere. To supply the heat which the sun throws off (enough to melt

Scale, 75,000 miles to the inch.

FIG. 18.

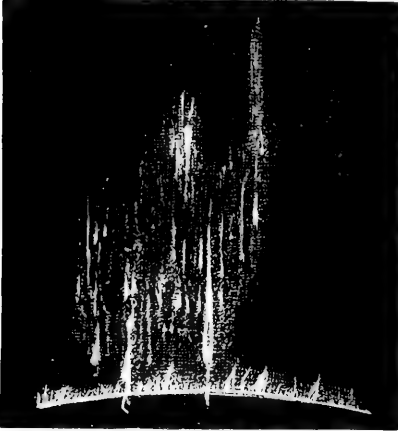

VERTICAL FILAMENTS.

FIG. 19.



CYCLONE.

FIG. 20.

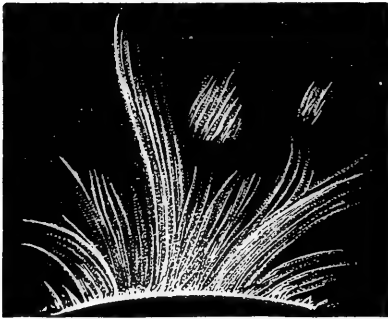

FLAMES.

FIG. 21.

PROMINENCE AS IT APPEARED AT HALF-PAST  
TWELVE O'CLOCK, SEPTEMBER 7, 1871.

FIG. 22.

AS THE ABOVE APPEARED HALF AN HOUR LATER,  
WHEN THE UPRUSHING HYDROGEN ATTAINED A  
HEIGHT OF MORE THAN 200,000 MILES.

FIG. 23.

SPOT NEAR THE SUN'S LIMB, WITH ACCOMPANYING  
JETS OF HYDROGEN, AS SEEN OCTOBER 5, 1871.

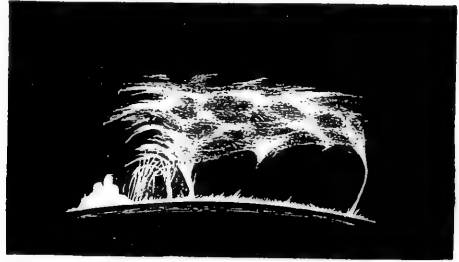
each minute a shell of ice nearly forty feet thick over his entire surface) would require the condensation of enough vapor to make a sheet of liquid five feet thick in the same time—supposing, that is, the latent heat of the solar vapors not greater than that of water vapors. This, of course, is uncertain, but, so far as we know, very few if any vapors contain more latent heat than that of water, and we may therefore consider it roughly correct to estimate the continuous production of



liquid as measured by the quantity named. Now, on the surface of the earth a rain-storm which deposits two inches in an hour is very uncommon—in such a storm the water falls in sheets. It is easy to see, then, that the quantity of liquid pouring from the solar clouds is so enormous that the drops could not be expected to remain separate, but must almost certainly unite into more or less continuous masses or sheets, between and through which the gases ascending from beneath must make their way. And since the weight of the vapors which ascend must continually equal that of the products of condensation which are falling, it is further evident that the upward currents, rushing through contracted channels, must move with enormous velocity, and therefore, of course, that the pressure and temperature must rapidly increase from the free surface downward. It would seem that thus we might explain how the upper surface of the hydrogen atmosphere is tormented by the up-rush from below, and how gaseous masses, thrown up from beneath, should, in the prominences, present the appearances which have been described. Nor would it be strange if veritable explosions should occur in the quasi pipes or channels through which the vapors rise, when, under the varying circumstances of pressure and temperature, the mingled gases reach their point of combination; explosions which would fairly account for such phenomena as those represented on page 400, when clouds of hydrogen were thrown to an elevation of more than 200,000 miles with a velocity which *must* have exceeded at first 200 miles per second, and very probably, taking into account the resistance of the solar atmosphere, may, as Mr. Proctor has shown, have exceeded 500; a velocity sufficient to hurl a dense material entirely clear of the power of the sun's attraction, and send it out into space, never to return.

But our limits forbid indulgence in such speculations; nor can we stop to discuss the interesting question concerning the relation between these solar eruptions and magnetic storms upon the earth. It must suffice to say that, while it is not probable that our greater magnetic disturbances are caused directly by solar influence, it is very nearly certain that every violent paroxysm upon the sun is distinctly and immediately responded to by our magnetometers.

Whether these solar storms produce any other effects upon the earth, has not been ascertained. Some are so sanguine as to expect that in the study of these phenomena will be found the key to many puzzling problems of terrestrial meteorology. We cannot say that we share the expectation; but the subject is certainly worthy of careful examination, and it is not possible to doubt that faithful labor in so new and fertile a field will be rewarded, if not with precisely the result anticipated, yet with some rich harvest.

## REPLIES TO CRITICISMS.

BY HERBERT SPENCER.

## II.

OBJECTIONS of another, though allied, class have been made in a review of the "Principles of Psychology," by Mr. H. Sidgwick—a critic whose remarks on questions of mental philosophy always deserve respectful consideration.

Mr. Sidgwick's chief aim is, to show what he calls "the mazy inconsistency of his [my] metaphysical results." More specifically he expresses thus the proposition he seeks to justify: "His view of the subject appears to have a fundamental incoherence, which shows itself in various ways on the surface of his exposition, but of which the root lies much deeper, in his inability to harmonize different lines of thought."

Before dealing with the reasons given for this judgment, let me say that, in addition to the value which candid criticisms have, as showing where more explanation is needed, they are almost indispensable as revealing to a writer incongruities he had not perceived. Especially where, as in this case, the subject-matter has many aspects, and where the words supplied by our language are so inadequate in number that, to avoid cumbrous circumlocution, they have to be used in senses that vary according to the context, it is extremely difficult to avoid imperfections of statement. But while I acknowledge sundry such imperfections and the resulting incongruities, I cannot see that these are, as Mr. Sidgwick says, fundamental. Contrariwise, their superficiality seems to me proved by the fact that they may be rectified without otherwise altering the expositions in which they occur. Here is an instance:

Mr. Sidgwick points out that, when treating of the "Data of Psychology," I have said (in § 56) that, though we reach inferentially "the belief that mind and nervous action are the subjective and objective faces of the same thing, we remain utterly incapable of seeing, and even of imagining, how the two are related" (I quote the passage more fully than he does). He then goes on to show that in the "Special Synthesis," where I have sketched the evolution of intelligence under its objective aspect, as displayed in the processes by which beings of various grades adjust themselves to surrounding actions, I "speak as if" we could see how consciousness "naturally arises at a particular stage" of nervous action. The chapter here referred to is one describing that "differentiation of the psychical from the physical life" which accompanies advancing organization, and more especially advancing development of the nervous system. In it I have aimed to show that, while the changes constituting physical life continue to be

characterized by the *simultaneity* with which all kinds of them go on throughout the organism, the changes constituting psychical life, arising as the nervous system develops, become more and more distinguished by their *seriality*: that with the advance of nervous integration "there must result an unbroken series of these changes—there must arise a consciousness." Now, I admit that here is an apparent inconsistency. I ought to have said that "there must result an unbroken series of these changes," which, taking place in the nervous system of a highly-organized creature, gives coherence to its conduct, and along with which we assume a consciousness, because consciousness goes along with coherent conduct in ourselves. If Mr. Sidgwick will substitute this statement for the statement as it stands, he will see that the arguments and conclusions remain intact. A survey of the chapter as a whole proves that its aim is not in the least to explain how nervous changes, considered as waves of molecular motion, become the feelings constituting consciousness; but that, contemplating the facts objectively in living creatures at large, it points out the cardinal distinction between vital actions in general, and those particular vital actions which, in a creature displaying them, lead us to speak of it as intelligent. It is shown that the rise of such actions becomes marked in proportion as the changes taking place in the part called the nervous system are made more and more distinctly serial, by union in a supreme centre of coördination. The introduction of the word consciousness arises in the effort to show what fundamental character there is in the physiological changes which is *parallel to* a fundamental character in the psychological changes.

Another instance of the way in which Mr. Sidgwick evolves an incongruity, which he considers fundamental, out of what I should have thought he would see is a defective expression, I will give in his own words. Speaking of a certain view of mine, he says:

"He tells us that 'logic . . . . contemplates in its propositions certain connections predicated, which are necessarily involved with certain other connections given: *regarding all these connections as existing in the non-ego*—not, it may be, under the form in which we know them, but in some form.' But in § 473, where Mr. Spencer illustrates by a diagram his 'Transfigured Realism,' the view seems to be this: although we cannot say that the real non-ego resembles our notion of it in 'its elements, relations, or laws,' we can say that 'a change in the objective reality causes in the subjective state a change exactly answering to it—so answering as to *constitute a cognition of it.*' Here the 'something beyond consciousness' is no longer said to be unknown, as its effect in consciousness 'constitutes a cognition of it.'"

This apparent inconsistency, marked by the italics, would not have existed, if, instead of "a cognition of it," I had said, as I ought to have done, "*what we call* a cognition of it"—that is, a relative cognition as distinguished from an absolute cognition. In ordinary language we speak of as cognitions those connections in thought which

so guide us in our dealings with things that actual experience verifies ideal anticipation. There is no direct resemblance whatever between the sizes, forms, colors, and arrangements, of the figures in an account-book, and the moneys or goods, debts or credits, represented by them; and yet the forms and arrangements of the written symbols are such as to answer in a perfectly exact way to stocks of various commodities and to various kinds of transactions. Hence we say, figuratively, that the account-book will "tell us" all about these stocks and transactions. Similarly, the diagram Mr. Sidgwick refers to illustrates the way in which symbols, registered in us by objects, may have forms and arrangements wholly unlike their objective causes and the *nexus* among those causes, while yet they are so related as to guide us correctly in our transactions with those objective causes, and *in that sense* constitute cognitions of them; though they no more constitute cognitions in the absolute sense than do the guiding symbols in the account-book constitute cognitions of the things to which they refer. So repeatedly is this view implied throughout the "Principles of Psychology," that I am surprised to find a laxity of expression raising the suspicion that I entertain any other.

To follow Mr. Sidgwick through sundry criticisms of like kind, which may be similarly met, would take more space than I can here afford. I must restrict myself now to that which he seems to regard as the "fundamental incoherence" of which these inconsistencies are signs. I refer to that reconciliation of Realism and Idealism considered by him as an impossible compromise. A difficulty is habitually felt in accepting a coalition after long conflict. Whoever has espoused one of two antagonist views, and, in defending it, has gained a certain comprehension of the opposite view, becomes accustomed to regard these as the only alternatives, and is puzzled by an hypothesis which is at once both and neither. Yet, since it turns out in nearly all cases, that of conflicting doctrines each contains an element of truth, and that controversy ends by combination of their respective half-truths, there is an *a priori* probability on the side of an hypothesis which qualifies Realism by Idealism.

Mr. Sidgwick expresses his astonishment, or rather bespeaks that of his readers, because, while I accept idealistic criticisms, I nevertheless defend the fundamental intuition of Common-Sense, and, as he puts it, "fires his [my] argument full in the face of Kant, Mill, and 'metaphysicians' generally."

"He tells us that 'metaphysicians' illegitimately assume that 'beliefs reached through complex intellectual processes' are more valid than 'beliefs reached through simple intellectual processes;' that the common language they use refuses to express their hypotheses, and thus their reasoning inevitably implies the common notions which they repudiate; that the belief of Realism has the advantage of 'priority,' 'simplicity,' 'distinctness.' But surely this prior, simple, distinctly affirmed belief is that of what Mr. Spencer terms 'crude Realism,'

the belief that the non-ego is *per se* extended, solid, even colored (if not resonant and odorous). This is what common language implies; and the argument by which Mr. Spencer proves the relativity of feelings and relations, still more the subtle and complicated analysis by which he resolves our notion of extension into an aggregate of feelings and transitions of feeling, leads us away from our original simple belief—that, e. g., the green grass we see exists out of consciousness as we see it—just as much as the reasonings of Idealism, Skepticism, or Kantism.”

On the face of it the anomaly seems great; but I should have thought that, after reading the chapter on “Transfigured Realism,” a critic of Mr. Sidgwick’s acuteness would have seen the solution of it. He has overlooked an essential distinction. All which my argument implies is that the direct intuition of Realism must be held of superior authority to the arguments of Anti-Realism, *where their deliverances cannot be reconciled*. The one point on which their deliverances cannot be reconciled is, the existence of an objective reality. But, while, against this intuition of Realism, I hold the arguments of Anti-Realism to be powerless, because they cannot be carried on without postulating that which they end by denying, yet, having admitted objective existence as a necessary postulate, it is possible to make valid criticisms upon all those judgments which Crude Realism joins with this primordial judgment: it is possible to show that a transfigured interpretation of properties and relations is more tenable than the original interpretation.

To elucidate the matter, let us take the most familiar case in which the indirect judgments of Reason correct the direct judgments of Common-Sense. The direct judgment of Common-Sense is that the Sun moves round the Earth. In course of time, Reason finds certain difficulties in accepting this *dictum* as true. Eventually, Reason hits upon an hypothesis which explains the anomalies, but which denies this apparently certain *dictum* of Common-Sense. What is the reconciliation? It consists in showing to Common-Sense a mode of interpretation which equally well corresponds with direct intuition, while it avoids all the difficulties. Common-Sense is reminded that the apparent motion of an object may be due either to its actual motion or to the motion of the observer; and that there are terrestrial experiences in which the observer thinks an object he looks at is moving, when the motion is in himself. Extending the conception thus given, Reason shows that, if the Earth revolves on its axis, there will result that apparent motion of the Sun which Common-Sense interpreted into an actual motion of the Sun; and the common-sense observer becomes thereupon able to think of sunrise and sunset as consequent on his position as a spectator on a vast revolving globe. Now, if the astronomer, setting out by recognizing these celestial appearances, and proceeding to evolve the various anomalies following from the common-sense interpretation of them, had drawn the conclusion that

there externally exist no Sun and no motion at all, he would have done what idealists do; and his arguments would have been equally powerless against the intuition of Common-Sense. But he does nothing of the kind. He accepts the intuition of Common-Sense respecting the reality of the Sun and the motion; but replaces the old interpretation of it by a new interpretation reconcilable with all the facts.

Just in the same way that, here, acceptance of the inexpugnable element in the Common-Sense judgment by no means involves acceptance of the accompanying judgments, so, in the case of Crude Realism, it does not follow that, while against the consciousness of an objective reality the arguments of Anti-Realism are utterly futile, they are therefore futile against the conceptions which Crude Realism forms of the objective reality. If Anti-Realism can show that, granting an objective reality, the interpretation of Crude Realism contains insuperable difficulties, the process is quite legitimate. And, its primordial intuition remaining unshaken, Realism may, on reconsideration, be enabled to frame a new conception which harmonizes with all the facts.

To show that there is not here the "mazy inconsistency" alleged, let us take the case of sound as interpreted by Crude Realism, and as reinterpreted by Transfigured Realism. Crude Realism assumes the sound present in consciousness to exist as such beyond consciousness. Anti-Realism proves the inadmissibility of this assumption in sundry ways (all of which, however, set out by talking of sounding bodies beyond consciousness, just as Realism talks of them); and then Anti-Realism concludes that we know of no existence save the sound as a mode of consciousness: which conclusion and all kindred conclusions, I contend, are vicious—first, because all the words used connote an objective activity; second, because the arguments are impossible without postulating at the outset an objective activity; and third, because no one of the intuitions, out of which the arguments are built, is of equal validity with the single intuition of Realism that an objective activity exists. But, now, the Transfigured Realism which Mr. Sidgwick thinks "has all the serious incongruity of an intense metaphysical dream" neither affirms the untenable conception of Crude Realism, nor, like Anti-Realism, draws unthinkable conclusions by suicidal arguments; but, accepting that which is essential in Crude Realism, and admitting the difficulties which Anti-Realism insists upon, reconciles matters by a reinterpretation analogous to that which an astronomer makes of the solar motion. Continuing all along to recognize an objective activity which Crude Realism calls sound, it shows that the sensation is produced by a succession of separate impacts which, if made slowly, may be separately identified, and which will, if progressively increased in rapidity, produce tones higher and higher in pitch. It shows by other experiments that sounding



bodies are in states of vibration, and that the vibration may be made visible. And it concludes that the objective activity is not what it subjectively seems, but is proximately interpretable as a succession of aërial waves. Thus Crude Realism is shown that while there unquestionably exists an objective activity corresponding to the sensation known as sound, yet the facts are not explicable on the original supposition that this is like the sensation; while they are explicable by conceiving it as a rhythmical mechanical action. Eventually this re-interpretation, joined with kindred reinterpretations of other sensations, comes to be itself further transfigured by analysis of its terms, and reëxpression of them in terms of molecular motion; but, however abstract the interpretation ultimately reached, the objective activity continues to be postulated: the primordial judgment of Crude Realism remains unchanged, though it has to change the rest of its judgments.

In another part of his argument, however, Mr. Sidgwick implies that I have no right to use those conceptions of objective existence by which this compromise is effected. Quoting sundry passages to show that, while I hold the criticisms of the Idealist to be impossible without "tacitly or avowedly postulating an unknown something beyond consciousness," I yet admit that "our states of consciousness are the only things we can know," he goes on to argue that I am radically inconsistent, because, in interpreting the phenomena of consciousness, I continually postulate not an unknown something, but a something of which I speak in ordinary terms, as though its ascribed physical characters really exist as such, instead of being, as I admit they are, synthetic states of my consciousness. His objection, if I understand it, is, that, for the purposes of Objective Psychology, I apparently profess to know Matter and Motion in the ordinary realistic way; while, as a result of subjective analysis, I reach the conclusion that it is impossible to have that knowledge of objective existence which Crude Realism supposes we have. Doubtless there seems here to be what he calls "a fundamental incoherence." But I think it exists, not between my two expositions, but between the two consciousnesses of subjective and objective existence, which we cannot suppress and yet cannot put into definite forms. The alleged incoherence I take to be but another name for the inscrutability of the relation between subjective feeling and its objective correlate which is not feeling—an inscrutability which meets us at the bottom of all our analyses. An exposition of this inscrutability I have elsewhere summed up thus:

"See, then, our predicament. We can think of Matter only in terms of Mind. We can think of Mind only in terms of Matter. When we have pushed our explorations of the first to the uttermost limit, we are referred to the second for a final answer; and, when we have got the final answer of the second, we are referred back to the first for an interpretation of it. We find the value of  $x$  in terms

of  $y$ ; then we find the value of  $y$  in terms of  $x$ ; and so on we may continue forever without coming nearer to a solution."—(*Principles of Psychology*, § 272.)

Carrying a little further this simile, will, I think, show where lies the insuperable difficulty felt by Mr. Sidgwick. Taking  $x$  and  $y$  as the subjective and objective activities, unknown in their natures and known only as phenomenally manifested, and recognizing the fact that every state of consciousness implies, immediately or remotely, the action of object on subject, or subject on object, or both, we may say that every state of consciousness will be symbolized by some modification of  $x y$ —the phenomenally-known product of the two unknown factors. In other words,  $xy'$ ,  $x'y$ ,  $x'y'$ ,  $x''y'$ ,  $x'y''$ , etc., etc., will represent all perceptions and thoughts. Suppose, now, that these are thoughts about the object; composing some hypothesis respecting its character as analyzed by physicists. Clearly, all such thoughts, be they about shapes, resistances, momenta, molecules, molecular motions, or what not, will contain some form of the subjective activity  $x$ . Now, let the thoughts be concerning mental processes. It must similarly happen that some mode of the unknown objective activity,  $y$ , will be in every case a component. Now, suppose that the problem is the genesis of mental phenomena, and that, in the course of the inquiry, bodily organization and the functions of the nervous system are brought into the explanation. It will happen, as before, that these, considered as objective, have to be described and thought about in modes of  $x y$ . And when by the actions of such a nervous system, conceived objectively in modes of  $x y$ , and acted upon by physical forces which are conceived in other modes of  $x y$ , we endeavor to explain the genesis of sensations, perceptions, and ideas, which we can think of only in other modes of  $x y$ , we find that all our factors, and therefore all our interpretations, contain the two unknown terms, and that no interpretation is imaginable that will not contain the two unknown terms.

What is the defense for this apparently circular process? Simply that it is a process of establishing *congruity* among our symbols. It is the finding a mode of so symbolizing the unknown activities subjective and objective, and so operating with our symbols, that all our acts may be rightly guided—guided, that is, in such ways that we can anticipate when, where, and in what quantity, one of our symbols will be found. Mr. Sidgwick's difficulty arises, I think, from having insufficiently borne in mind the statements made at the outset, in "The Data of Philosophy," that such conceptions as "are vital, or cannot be separated from the rest without mental dissolution, must be assumed true *provisionally*;" that "there is no mode of establishing the validity of any belief except that of showing its entire *congruity* with all other beliefs," and that "Philosophy, compelled to make those fundamental assumptions without which thought is impossible,

has to justify them by showing their *congruity* with all other dicta of consciousness." In pursuance of this distinctly-avowed mode of procedure, I assume as true, provisionally, certain modes of formulating the manifestations of the unknown objective activity, certain modes of formulating the manifestations of the unknown subjective activity, and certain resulting modes of conceiving the operations of the one on the other. These provisional assumptions having been carried out to all their consequences, and these consequences proved to be congruous with one another and with the original assumptions, these original assumptions are justified; and, if, finally, I assert, as I have repeatedly asserted, that the terms in which I express my assumptions and carry on my operations are but symbolic, and that all I have done is to show that, by certain ways of symbolizing, perfect harmony results—invariable agreement between the symbols in which I frame my expectations and the symbols which occur in experience—I cannot be blamed for incoherence. Lastly, should it be said that this regarding of every thing constituting experience and thought as symbolic has a very shadowy aspect, I reply that these which I speak of as symbols are real relatively to our consciousness, and are symbolic only in their relation to the Ultimate Reality.

That these explanations will make clear the coherence of views which before seemed "fundamentally incoherent," I feel by no means certain; since, as I did not perceive the difficulties presented by the exposition as at first made, I may similarly fail to perceive the difficulties in this explanation. Originally, I had intended to complete the "Principles of Psychology" by a division showing how the results reached in the preceding divisions, physiological and psychological, analytic and synthetic, subjective and objective, harmonized with one another, and were but different aspects of the same aggregate of phenomena. But the work was already bulky; and I concluded that this division might be dispensed with, because the congruities to be pointed out were sufficiently obvious. So little was I conscious of the alleged "inability to harmonize different lines of thought." Mr. Sidgwick's perplexities, however, show me that such an exposition of concords is needful.

I have reserved to the last one of the first objections made to the metaphysico-theological doctrine set forth in "First Principles," and implied in the several volumes that have succeeded it. I refer to one urged by an able metaphysician, the Rev. James Martineau, in an essay entitled "Science, Nescience, and Faith," and which, effective against my argument as it stands, shows the need for some further development of my argument. That Mr. Martineau's criticism may be understood, I must quote the passages it concerns. Continuing the reasoning employed against Hamilton and Mansel, to show that our consciousness of that which transcends knowledge is *positive*, and not, as they allege, *negative*, I have said:

“Still more manifest will this truth become when it is observed that our conception of the Relative itself disappears, if our conception of the Absolute is a pure negation. It is admitted, or rather it is contended, by the writers I have quoted above, that contradictories can be known only in relation to each other—that Equality, for instance, is unthinkable apart from its correlative Inequality; and that thus the Relative can itself be conceived only by opposition to the Non-relative. It is also admitted, or rather contended, that the consciousness of a relation implies a consciousness of both the related members. If we are required to conceive the relation between the Relative and Non-relative without being conscious of both, ‘we are in fact (to quote the words of Mr. Mansel differently applied) required to compare that of which we are conscious with that of which we are not conscious; the comparison itself being an act of consciousness, and only possible through the consciousness of both its objects.’ What, then, becomes of the assertion that ‘the Absolute is conceived merely by a negation of conceivability,’ or as ‘the mere absence of the conditions under which consciousness is possible?’ If the Non-relative or Absolute is present in thought only as a mere negation, then the relation between it and the Relative becomes unthinkable, because one of the terms of the relation is absent from consciousness. And if this relation is unthinkable, then is the Relative itself unthinkable, for want of its antithesis: whence results the disappearance of all thought whatever.”—(*First Principles*, § 26.)

On this argument Mr. Martineau comments as follows; first restating it in other words:

“Take away its antithetic term, and the relative, thrown into isolation, is set up as absolute, and disappears from thought. It is indispensable, therefore, to uphold the Absolute in existence, as condition of the relative sphere which constitutes our whole intellectual domain. Be it so; but, when saved on this plea—to preserve the balance and interdependence of two *co-relatives*—the ‘Absolute’ is absolute no more; it is reduced to a term of relation; it loses therefore its exile from thought; its disqualification is canceled; and the alleged nescience is discharged.

“So, the same law of thought which warrants the existence, dissolves the inscrutableness, of the Absolute.”—(*Essays, Philosophical and Theological*, pp. 186, 187.)

I admit this to be a telling rejoinder; and one which can be met only when the meanings of the words, as I have used them, are carefully discriminated, and the implications of the doctrine fully traced out. We will begin by clearing the ground of minor misconceptions.

First, let it be observed that, though I have used the word Absolute as the equivalent of Non-relative, because it is used in the passages quoted from the writers I am contending against, yet I have myself chosen for the purposes of my argument the name Non-relative, and I do not necessarily commit myself to any propositions respecting the Absolute, considered as that which includes both Subject and Object. The Non-relative, as spoken of by me, is to be understood rather as the totality of Being *minus* that which constitutes the individual consciousness, present to us under forms of Relation. Did I use the word in some Hegelian sense, as comprehensive of that which thinks

and that which is thought about, and did I propose to treat of the order of things, not as phenomenally manifested but as noumenally proceeding, the objection would be fatal. But, the aim being simply to formulate the order of things as present under relative forms, the antithetical Non-relative here named as implied by the conception of the Relative is that which, in any act of thought, is independent of and beyond it, rather than which is inclusive of it. Further, it should be observed that this Non-relative, spoken of as a necessary complement to the Relative, is not spoken of as a conception but as a *consciousness*; and I have in sundry passages distinguished between those modes of consciousness which, having limits, and constituting thought proper, are subject to the laws of thought, and the mode of consciousness which persists when the removal of limits is carried to the uttermost, and when distinct thought consequently ceases.

This opens the way to the reply here to be made to Mr. Martineau's criticism, namely: that while by the necessities of thought the Relative implies a Non-relative; and while, to think of this antithesis completely, requires that the Non-relative shall be made a conception proper; yet, for the vague thought which is alone in this case possible, it suffices that the Non-relative shall be present as a consciousness which though undefined is positive. Let us observe what necessarily happens when thought is employed on this ultimate question.

In a preceding part of the article criticised, I have, in various ways, aimed to show that, alike when we analyze the product of thought and when we analyze the process of thought, we are brought to the conclusion that invariably "a thought involves *relation, difference, likeness*;" and that, even from the very nature of Life itself, we may evolve the conclusion that, "thinking being relationing, no thought can ever express more than relations." What now must happen if thought, having this law, occupies itself with the final mystery? Always implying terms in relation, thought implies that both terms shall be more or less defined; and, as fast as one of them becomes indefinite, the relation also becomes indefinite, and thought becomes indistinct. Take the case of magnitudes. I think of an inch; I think of a foot; and, having tolerably definite ideas of the two, I have a tolerably definite idea of the relationship between them. I substitute for the foot a mile; and, being able to represent a mile much less definitely, I cannot so definitely think of the relation between an inch and a mile—cannot distinguish it in thought from the relation between an inch and two miles, as clearly as I can distinguish in thought the relation between an inch and one foot from the relation between an inch and two feet. And now if I endeavor to think of the relation between an inch and the 240,000 miles from here to the moon, and the relation between an inch and the 92,000,000 miles from here to the sun, I find that while these distances, practically inconceivable, have become little more than numbers to which I frame no answering ideas, so, too, have

the relations between an inch and either of them become practically inconceivable. Now, this partial failure in the process of forming thought-relations, which happens even with finite magnitudes when one of them becomes immense, becomes complete failure when one of the magnitudes cannot be brought within any limits. The relation itself becomes unrepresentable at the same time that one of its terms becomes unrepresentable. Nevertheless, in this case it is to be observed that the almost blank form of relation preserves a certain qualitative character. It is still distinguishable as belonging to the consciousness of extensions, not to the consciousnesses of forces or durations; and in so far remains a vaguely-identifiable relation. But now suppose we ask what happens when one term of the relation has not simply magnitude having no known limits, and duration of which neither beginning nor end is cognizable, but is also an existence not to be defined? In other words, what must happen if one term of the relation is not only quantitatively but also qualitatively unrepresentable? Clearly in this case the relation does not simply cease to be thinkable except as a relation of a certain class, but it lapses completely. When one of the terms becomes wholly unknowable, the law of thought can no longer be fulfilled; both because one term cannot be present, and because at the same time relation itself cannot be framed. That is to say, the law of thought, that contradictories can be known only in relation to each other, fails when thought attempts to transcend the Relative; and yet, when it attempts to transcend the Relative, it must make the attempt in conformity with its law—must in some dim mode of consciousness posit a Non-relative, and, in some similarly dim mode of consciousness, a relation between it and the Relative. In brief, then, to Mr. Martineau's objection I reply, that the insoluble difficulties he indicates arise here, as elsewhere, when thought is applied to that which transcends the sphere of thought; and that, just as, when we try to pass beyond phenomenal manifestations to the Ultimate Reality manifested, we have to symbolize it out of such materials as the phenomenal manifestations give us, so we have simultaneously to symbolize the connection between this Ultimate Reality and its manifestations as somehow allied to the connections among the phenomenal manifestations themselves. The truth Mr. Martineau's criticism adumbrates is, that the law of thought fails where the elements of thought fail; and this is a conclusion quite conformable to the general view I defend. Still holding the validity of my argument against Hamilton and Mansel, that in pursuance of their own principle the Relative is not at all thinkable as such, unless in contradistinction to some existence posited, however vaguely, as the other term of a relation conceived, however indefinitely, it is, I think, consistent on my part to hold that, in this effort which thought inevitably makes to pass beyond its sphere, not only does the product of thought become a dim symbol of a product, but the process of thought becomes a dim



symbol of a process; and hence any predicament inferable from the law of thought cannot be asserted.

I may fitly close this reply by a counter-criticism. To the direct defense of a proposition, there may be added the indirect defense that results from showing the untenability of an alternative proposition. This criticism on the doctrine of an unknowable existence, manifested to us in phenomena, Mr. Martineau makes in the interests of the doctrine held by him, that this existence is, to a considerable degree, knowable. We are quite at one in holding that there is an indestructible consciousness of Power behind Appearance; but, whereas I contend that this Power cannot be brought within the forms of thought, Mr. Martineau contends that there can be consistently ascribed certain attributes of personality—not, indeed, human characteristics so concrete as were ascribed in past times; but still, human characteristics of the more abstract and higher class. Regarding matter as independently existing; regarding, as also independently existing, those primary qualities of Body “which are inseparable from the very idea of Body, and may be evolved *a priori* from the consideration of it as solid extension or extended solidity;” and saying that to this class “belong Triple Dimension, Divisibility, and Incompressibility;” Mr. Martineau goes on to say that as these

“cannot absent themselves from Body, they have a reality coeval with it, and belong eternally to the material datum objective to God; and his mode of activity with regard to them must be similar to that which alone we can think of his directing upon the relations of space, viz., not Volitional, to cause them, but Intellectual, to think them out. The Secondary Qualities, on the other hand, having no logical tie to the Primary, but, being appended to them as contingent facts, cannot be referred to any deductive thought, but remain over as products of pure Inventive Reason and Determining Will. This sphere of cognition *a posteriori* to us—where we cannot move a step alone, but have submissively to wait upon experience—is precisely the realm of Divine originality: and we are most sequacious where He is most free. While on this Secondary field his Mind and ours are thus contrasted, they meet in resemblance again upon the Primary; for the evolutions of deductive Reason there is but one track possible to all intelligences; no *merum arbitrium* can interchange the false and true, or make more than one geometry, one scheme of pure Physics for all worlds; and the Omnipotent Architect himself, in realizing the Cosmical conception, in shaping the orbits out of immensity and determining seasons out of eternity, could but follow the laws of curvature, measure, and proportion.”—(*Essays, Philosophical and Theological*, pp. 163, 164.)

Before the major criticism which I propose to make on this hypothesis, let me make a minor one. Not only of space relations, but also of primary physical properties, Mr. Martineau asserts the necessity: not a necessity to our minds simply, but an ontological necessity. What is true for human thought, is, in respect of these, true absolutely: “the laws of curvature, measure, and proportion,” as we know them, are unchangeable even by Divine power; as are also the

Divisibility and Incompressibility of Matter. But, if, in these cases, Mr. Martineau holds that a necessity in thought implies an answering necessity in things, why does he refrain from saying the like in other cases? Why, if he tacitly asserts it in respect of space-relations and the statical attributes of Body, does he not also assert it in respect of the dynamical attributes of Body? The laws conformed to by that mode of force now distinguished as "energy" are as much necessary to our thought as are the laws of space-relations. The axioms of Mechanics lie on the same plane with the axioms of pure Mathematics. Now, if Mr. Martineau admits this, as he cannot but do—if he admits, as he must, the corollary that there can be no such manifestation of energy as that displayed in the motion of a planet, save at the expense of equivalent energy which preëxisted—if he draws the further necessary corollary that the direction of a motion cannot be changed by any action, without an equal reaction in an opposite direction on something acting—if he bears in mind that this holds not only of all visible motions, celestial and terrestrial, but that those activities of Body which affect us as secondary properties are also known only through other forms of energy which are equivalents of mechanical energy—and if, lastly, he infers that none of these derivative energies can have given to them their characters and directions, save by preëxisting forces, statical and dynamical, conditioned in special ways—what becomes of that "realm of a Divine originality" which Mr. Martineau describes as remaining within the realm of necessity? Consistently carried out, his argument implies a universally-inevitable order, in which volition can have no such place as that he alleges.

Not pushing Mr. Martineau's reasoning to this conclusion, so entirely at variance with the one he draws, but accepting his statement just as it stands, let us consider the solution it offers us. We are left by it without any explanation of Space and Time; we are not helped in conceiving the origin of Matter; and there is afforded us no idea how Matter came to have its primary attributes. All these are tacitly assumed to exist uncreated. Creative activity is represented as under the restrictions imposed by mathematical principles, and as having for datum (mark the word) a substance which, in respect of certain characters, defies modification. But surely this is not an interpretation of the mystery of things. The mystery is simply relegated to a remoter region, respecting which no inquiry is to be made. But the inquiry *must* be made. After every such solution there arises afresh the question, What are the origin and nature of that which imposes these limits on creative power? what is the primary God which dominates over this secondary God? For, clearly, if the "Omnipotent Architect himself" (to use Mr. Martineau's somewhat inconsistent name) is powerless to change the "material datum objective" to him, and powerless to change the conditions under which it exists, and under

which he works, there is obviously implied a power to which he is subject. So that, in Mr. Martineau's doctrine also, there is an Ultimate Unknowable; and it differs from the doctrine he opposes only by intercalating a partially Knowable between this and the wholly Knowable.

Finding, as explained above, that this interpretation is not consistent with itself, and finding, as just shown, that it leaves the essential mystery unsolved, I do not see that it has an advantage over the doctrine of the Unknowable in its unqualified shape. There cannot, I think, be more than temporary rest in a proximate solution which takes for its basis an ultimate insolubility. Just as thought cannot be prevented from passing beyond Appearance, and trying to conceive the Cause behind, so, following out the interpretation Mr. Martineau offers, thought cannot be prevented from asking what Cause it is which restricts the Cause he assigns. And if we must admit that the question under this eventual form cannot be answered, may we not as well confess that the question under its immediate form cannot be answered? Is it not better candidly to acknowledge the incompetence of our intelligence, rather than to persist in calling that an explanation which does but disguise the inexplicable? Whatever answer each may give to this question, he cannot rightly blame those who, finding in themselves an indestructible consciousness of an Ultimate Cause, whence proceed alike what we call the Material Universe and what we call Mind, refrain from affirming any thing respecting it, because they find it as inscrutable in nature as it is inconceivable in extent and duration.

---

## MODERN OPTICS AND PAINTING.<sup>1</sup>

By O. N. ROOD,

PROFESSOR OF PHYSICS IN COLUMBIA COLLEGE.

### LECTURE I.

MODERN science has taught us that the portion of the material universe with which we are acquainted is swept from end to end by vibrations, that we are immersed in a sea whose very substance is constantly pulsating under the influence of systems and counter-systems of waves, and that even our very sensations are largely dependent on the action of these undulations upon ourselves. Now, the laws which rule these waves, comparatively speaking, are few and simple; the waves, taken by themselves, are modes of motion which are moderately intelligible; they obey well-known mechanical laws, and can be subjected to ordinary methods of computation. But, when we come to consider their action on living beings, the case is quite

<sup>1</sup> Two lectures delivered before the National Academy of Design.

altered; the effects are strange, unexpected, and the method of their production involved in mystery.

Let me take some examples, and the first shall be a coarse, rough one, involving powerful effects and sensations. If, by the aid of properly-contrived machinery, we communicate merely to the hand fifty or sixty energetic vibrations in a second, a peculiar and powerful sensation is produced, resembling that of a prolonged electric shock, and at the same time the hand becomes clinched, and cannot be opened by an effort of the will. In this experiment the vibrations are communicated to the hand by direct contact with a solid piece of metal. Let us select a more refined case, and employ as the exciting cause twenty or twenty-five vibrations per second, not of metal, but of air. Helmholtz found that, when vibrations of this kind, or, what is the same thing, when aerial waves, forty or fifty feet in length, were presented to the ear, the result was not sound, but an unbearable tickling sensation; as he shortened the waves, the effect altered gradually, until at last, when their length had been reduced to about thirty feet, he perceived a low, deep, musical note. If we undertook to extend his experiment, we should find that shortening the length of the wave raised the pitch of the note; that waves, five or six inches in length, furnished quite shrill notes; and that, finally, upon diminishing the wave-length to three or four tenths of an inch, the sound would become inaudible. It is quite certain that vast multitudes of still shorter waves exist, but we are deaf and blind to them; in us they excite no sensation. At this point there begins for us a great blank, in which, as Prof. Peirce once remarked, there is room for the play of not less than a dozen new senses, each as extensive as that of sight. Crossing, in imagination, this vast, unknown chasm, let us still pursue the shortening waves, and endeavor to trace their presence in a new region. We began with the heavy vibrations, the hammer-like strokes of a rod of metal, and exchanged them for the gentler aerial pulses, but now the air itself has become too coarse to transmit the far more delicate and minute waves which we next encounter: this is a feat which can only be accomplished by the all-pervading ether. Our new waves are very short; an army of ten thousand, marching in single file, would find room in an inch; but, though small, they are swift in motion: they will travel seven times around the earth in a second, and then be prepared for an interstellar journey. When they impinge on us, compensating for small size by vast number, they still produce a powerful sensation—we call it heat. Their effect upon the ear or eye is about the same as upon any other portion of the body; our ears are deaf, our eyes blind to them. But the state of the case alters when their length has been reduced to about the thirty-thousandth of an inch; they now become capable of acting on the eye, and with its aid we begin to perceive a faint red-brown color. Always shortening our wave-length, we find that the tint brightens into a pure red hue, changes

gradually into an orange tint, and, gaining greatly in luminosity, becomes pure yellow; passing thence by gradations into green and blue, it gently fades out in a violet and faint violet-gray or lavender. Beyond this point are yet more minute waves, but, in pursuing them, we enter once more what is for us a region of silence and darkness, and we are compelled to feel our way with the help of photographic plates.

The series of tints just mentioned is now on the screen, and, were it worth while, the existence of systems of invisible waves upon either side could easily be demonstrated. The statements that I have made lead us, however, a little unexpectedly to a remarkable conclusion. They show that the beautiful colors now displayed have no existence outside of ourselves—that, outside of ourselves, there are merely waves, longer or shorter. Color is a sensation existing merely in ourselves. On the other hand, our eyes might have been made quite insensible to color while still preserving the power of vision, and it is not impossible for us to conceive the existence of beings to whom the luminous waves might only be what to us are the breakers on a sea-beach.

But, to resume: if we allow all these luminous waves to act simultaneously upon the eye, we obtain, not, as might perhaps be expected, a still richer and more gorgeous tint, but simply the sensation called white—brightness without color.

Now, it happens somewhat remarkably that all the color sensations I have mentioned, and all intermediate ones, can be approximately reproduced by the mixture in various proportions of merely three powders: when viewed by ordinary daylight one of the powders must be capable of reflecting red light, the others yellow and blue light respectively, that is to say, they must reflect abundantly the waves capable of producing these three sensations; the rest of the waves falling on them they must absorb and destroy, to a greater or less extent; or, finally, in common language, out of the mixture of red, yellow, and blue pigments, all the colors can be produced. This fact has been known for ages—it was old in the time of the Greeks, and probably dates back to that early period when the first serious attempts at painting were made by the human race. What could be more natural than that it should lead to the theory of the existence of only three *primary colors*, red, yellow, and blue, out of which all the others could be compounded: thus, orange out of a mixture of red and yellow, green by blue and yellow, and violet from red and blue. This theory was firmly established before Newton's time. During the present century it was the glory of one of England's greatest physicists that he had strengthened its foundations (it is found in most text-books on physics and art), and is to-day almost universally credited by painters. We have here upon the screen its well-known typical expression: three overlapping circles, the red one producing orange where it crosses

the yellow, and violet where it overlies the blue, the yellow and blue giving a bright green, while the central space, under the action of all the colors, is white (Fig. 1). As I said, the diagram now on the screen is the *typical* expression of the old theory, and is constructed so as to humor as much as possible the ideas of its supporters. If I had selected three pigments, and honestly worked the diagram out by their mixture, the result would have been much less brilliant and attractive.

FIG. 1.

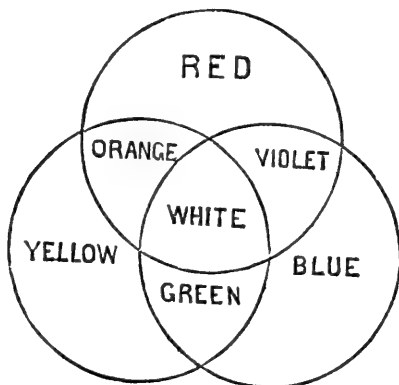

Let me make an actual experiment on this point: I throw upon the screen the image of three plates of stained glass; their colors are red, yellow, and blue; they are also rich and intense. These pieces are arranged so as to correspond to our three colored circles, and, in fact, where the blue crosses the yellow, a green hue is actually produced, but it is darker than either of its constituents; the violet is much darker than the red or blue, and, where all the plates cross at the centre, we have, instead of white light, complete darkness (Fig. 2). These peculiar strides in each case toward blackness would have been observed, if a corresponding experiment had been made with any three *pigments*, but this at present is a minor matter, and I leave it for the consideration of a vastly greater difficulty under which the old theory labors.

Let us inquire how the superimposed yellow and blue glasses came to produce green. The white light of the lantern contains all the different luminous waves, and it so happens that the yellow and blue glasses both agree mainly in transmitting only waves of a medium length, or, what is the same thing, green light. This can be proved by an examination with the spectroscope, which also reveals the fact that their agreement in this respect is by no means perfect, and that the green rays are also compelled to pay toll for their passage, though in a less proportion than the others. Exactly the same reasoning applies to blue and yellow pigments, and, from the effects produced by their mixture, it does not in the least follow that yellow and blue light make green light. This important point I now propose to test by what may be considered a fundamental experiment. For this pur-



pose, the superposition of the blue and yellow tints furnished by polarized light has lately sometimes been used, but, though the result obtained is quite correct, it may be objected that this experiment was perfectly well known to Sir David Brewster, the great modern defender of the old theory, as well as to all the physicists who were his followers; and this knowledge does not seem in the least, for more than a quarter of a century, to have weakened their confidence. Nor

FIG. 2.

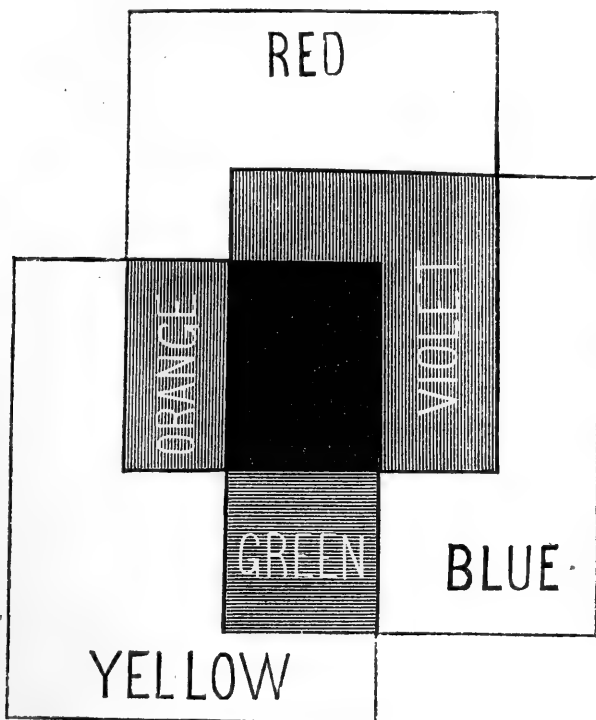

would it be perfectly satisfactory if I should bring about the union of blue and yellow light by the method of revolving colored disks, as is so often done; for, when we come to analyze this latter plan, we find that it consists, essentially, in presenting yellow and blue light to the eye, not simultaneously, but by a distinct succession of alternate acts. It is true that in this convenient mode of experimenting the results are the same as in that of simultaneous presentation, but just this point again would require proof, and, in a fundamental experiment like the present, ought not to be passed over in silence. To avoid these difficulties, I have contrived another plan, which will admit of our readily grasping the whole process, and inspecting its quite simple details. We have now upon the screen two large squares of blue light, and near them are two corresponding squares of yellow light (Fig. 3), and I can readily contrive matters so that the portion of the screen which is illuminated by one of the yellow squares shall also receive the light of a blue square. This we now have, and the result, as you see, is not the production of green light, or of light whose hue at all

approaches green; the light is *white*, with a slight tint of pink (Fig 4). Now, in this experiment, I have obtained our white light by the actual mixture on the screen of yellow and blue light, furnished by the *same* two glasses which, a little while ago, when superimposed,

FIG. 3.

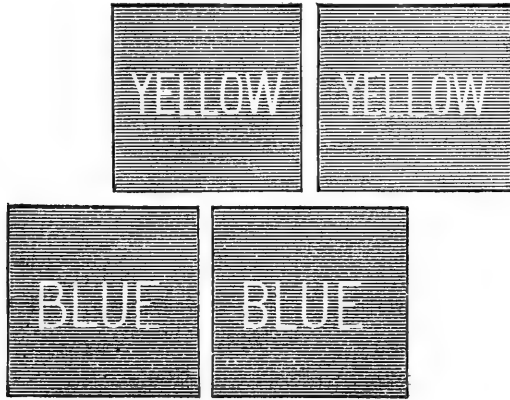

gave us green light. The apparatus is so contrived that the glasses send toward the screen yellow and blue beams of light, but, before traveling far from the lantern, these beams are caught by this large crystal of calc-spar, and each, as you see, is duplicated. Let us pursue this matter a little further, and, to facilitate our judgment of the tints, I throw on the screen, near the colored squares, a circle of unaltered white light, for comparison. Perhaps we have failed to produce green light from the circumstance that our yellow squares were too bright; with a simple contrivance I can diminish their luminosity without altering their tint, and the rate of diminution you can easily watch in

FIG. 4.



the uncombined yellow square. This apparatus is now acting, but though under its influence the tint of the central square changes, passing from white by a series of gradations into blue, you see that it manifests no tendency to become green. Restoring the yellow squares to their original brightness, in the same way I gradually cut down the brightness of the blue squares, and yet fail to generate any hue approaching green.

A result like this ought to shake, if not entirely destroy, our confidence in the old theory, but Helmholtz has pursued the investigation still further, and has proved, in addition, that the union of the pure yel-

low and blue light of the spectrum itself furnishes not green but white light. There are also other points of almost equal importance where the old theory is at variance with the facts of Nature; some of them will be noticed further on, but, for the present, in summing up this matter, we may say that, while the old theory answers tolerably—only indifferently well for mixture of pigments on the painter's palette—it quite fails when applied with any exactitude to the explanation or study of effects of color in Nature.



## SANITARY SCIENCE AND PUBLIC INSTRUCTION.<sup>1</sup>

BY ANDREW D. WHITE, LL. D.,

PRESIDENT OF CORNELL UNIVERSITY.

YOU are well aware that it is not by virtue of any special claims as an investigator in sanitary science, or as a student in it to any great extent, that I now address you. But, when I was invited to speak, it seemed a good opportunity to make one more point in behalf of certain great, manly studies in our system of public instruction, and especially in our institutions for advanced instruction, and therefore an opportunity not to be neglected.

The generations that come after us will doubtless wonder at what this age has done, but I think they will wonder far more at what it has not done. There will be wonder at discoveries, inventions, reforms—at all our conquests in the realms of mind and matter; but I think the wonder will grow when notice is taken of the utter neglect, in great systems of education, of the most important subjects which occupy us, either for material purposes or for mental and moral advancement. Look, first, at the neglect of political studies. Here is a great Republic, dependent, as all confess, upon the knowledge of those who live beneath its sway. And yet you may go from one end of the country to the other and hardly find the slightest provision for any real instruction in Political Science, whether it be in political economy or political history. If, during the war of our rebellion, any thoughtful American wished to find out what that history was in which the germs of that great struggle were planted and developed, he had to go for such knowledge to the public lecture-room of Laboulaye at Paris, or the private lecture-room of Neumann at Berlin.

The case is still worse in regard to that great class of studies comprehended under the designation of Social Science. Every year our national Legislature and some forty State and Territorial Legislatures, and a vast number of county and town boards, are brought face to face with the most vital social problems. They are called upon to

<sup>1</sup> Read at the recent meeting of the American Public Health Association.

make great expenditures for the prevention and cure of pauperism, for the repression and punishment of crime, for the treatment of lunatics of various sorts, for the care of idiots of various grades, for the special treatment of inebriates, for the cure of the sick in hospitals, for general measures of prevention, as regards epidemics, and yet no one will gainsay my assertion that on no subject are our Legislature, and all our various public bodies, so utterly blind as on this. If we look at the result of this as regards expenditure, the case is bad enough. The amount annually expended in all our States for this purpose is enormous. The only approach which we have to the palaces of the Old World are in the various hospitals and prisons and asylums of the New. I can speak of this want of knowledge from personal experience. I can stand in the confessional on this subject. It has been my lot more than once to vote on such appropriations in a legislative body. I remember especially one case where the Legislature of this State was called upon to establish a great asylum, at vast expense, for a certain class of lunatics. The case was very pressing. A careful report from a commission showed that some provision of this sort must be made. A bill was passed, the buildings were erected, and yet, when all was done, we were assured by an expert, who had no interest one way or the other in the matter, that all our well-meant benevolence had, perhaps, resulted in almost as much evil as good, and that the whole institution was a failure as regards the immediate purposes for which it was erected. The simple cause for this was that in that whole Legislature, in the lower House, in the upper House, in the Executive Department, there was not one person who had ever given any close attention to subjects of this kind, and we had been obliged to trust entirely to those who could give us scraps of information, no matter how crude. But, if the immediate results are unfortunate, the remote results are still more so.

If any one wishes to see what vicious methods of dealing with great social questions will produce, he has only to look at the great harvest of evil which England is now reaping from seed sown 300 years ago, especially as regards the treatment of her pauper and criminal classes. I have said that there is no provision for thorough instruction. The reason is twofold. The first is the reluctance of educators to take up new subjects of study, or, at least, to present them thoroughly. But the other and far more effective reason is the fact that we have so few institutions for advanced education which have the means to make provision for such teaching. The last report of the Commissioners of Education at Washington shows that we have in this country about 400 establishments calling themselves colleges or universities. You may count on your fingers all those which really have any claim to either title. In obedience to the demands of sect or of locality, we have gone on multiplying institutions insufficiently endowed, wretchedly wanting in every thing necessary to scientific

investigation, until we have now hardly three or four in possession of the means to present any new subject of study involving any outlay for investigation or for demonstration. The time has come when such provision should be made. Whether it is to be made by the munificence of private individuals, or by State endowments, is not here the question.

The proposition to which I shall speak especially is this: that provision should be made for instruction in Human Physiology, Hygiene, and Sanitary Science, in all departments of public instruction in our public schools, by providing fundamental instruction, especially in the simple principles of physiology and hygiene; in colleges and universities, by presenting this general instruction in a more extended way, and by promoting investigation; in medical colleges, by giving more special instruction in matters relating to public and international hygiene; and that, in our departments of engineering and polytechnic and technological schools, especial provision should be made for instruction in sanitary engineering.

In regard to the first of these provisions, that for popular instruction, few probably are aware of the need of them. Take, for example, the revelation made within the past year, at the outbreak of yellow fever in a Southern city. Two things in relation to that revealed very clearly the evils of which I speak: First, the cause assigned to the disease shows the utter want of sanitary knowledge in the people at large; and, secondly, the real cause, since revealed, shows the absolute blindness to the simplest principles of sanitary science on the part of those immediately concerned. When the yellow fever broke out at Shreveport, it was telegraphed all over the country that it was caused by the removal of the obstructions in the river above the city. That statement went all over the country unchallenged. So far as I know, no one thought of expressing doubt publicly as to the statement that the yellow fever was caused by a more plentiful supply of water at the wharves of that city—the fact being that this would conduce rather to the removal of the causes of the disease than to the prevention of them. At last came information as to the real cause, and it was found that in that hot climate men had been allowed to heap up the material in which disease-germs arise abundantly; that the simplest truths of sanitary science had been ignored, and that the consequence was perfectly simple and natural.

But it is not merely in such outstanding parts of the nation that such ignorance exists. It is spread throughout our own country districts, even the most enlightened districts, and you will find prevailing in many of our country towns traditions and superstitions in regard to this matter that are most surprising. You will find some of these things which are known to be absolutely deadly considered on the whole as healthful. Strange as it may seem, you may hear people who take the papers, who are supposed to be within reach of the great

sources of information—you may hear such people, I say, maintaining that, after all, the emanations of the cesspool are rather conducive to health than to disease; that their fathers lived and thrived in such an atmosphere, and that, therefore, it has a healthy influence. I can point you to an exceedingly pleasant village which I have sometimes to visit, where, with a plentiful supply of water, there is an absolute want of any system of sewerage. Typhoid and typhus go zigzag through that town every year or two, making victims, yet you can't induce the people of that village to believe that their unsewered condition has any thing to do with it.

But it is not merely in the country districts that this state of things has existed. Up to a very recent period at least this same ignorance was manifested in a very surprising degree in this metropolis. It is now about five years since, with two other members of our State Senate, I visited this city, and sat in the Commission for examining into certain branches of the city administration, and especially into the conduct of that branch which had the care of the public health. The state of things revealed was such as could only exist under a great and wide-spread ignorance on the part of citizens of the first principles of Sanitary Science. To give an idea of this ignorance, let me recall, as nearly as I can, a little episode in the investigation: It happened that the late Judge Whiting, who had charge of the investigation on the part of the Citizens' Association, put on the stand a young physician, who testified that the Health Officers, or Wardens, or Inspectors, were men utterly ignorant of the first principles relating to the public health which they were appointed to preserve. In order to refute this, the head of the Health Department at the time brought on the stand, in perfect good faith, several of these Health Officers. Toward the close of the examination of the first (one) of these gentlemen, Judge Whiting asked this question: "Did you have a case of small-pox in your ward?" and he answered, "Yes, sir." *Judge Whiting*: "Did you visit the patient?" *Witness*: "No, sir." *Judge Whiting*: "Why not?" *Witness*: "For the same reason that you would not; that I was afraid of taking it myself." *Judge Whiting*: "Did the family have any care?" *Witness*: "Yes, sir; they were 'highjinnicks' (hygienics); they doctored themselves." As the other witnesses came in, Judge Whiting used this as a sort of test question—as a sort of key to unlock the system, and show the utter ignorance that prevailed in every department of it. Every witness was asked: "Well, have you any 'highjinnicks' in your ward?" Some of the witnesses thought they had; some thought they had not; some thought they "had them pretty badly;" some thought they had them in some parts of the ward, some thought they had them in other parts of the ward. At last the Judge asked a witness, who had been answering his question in this way: "Do you know what the word 'highjinnicks' means?" and he replied: "Yes, sir, I do; it means a bad smell aris-



ing from dirty water." Of course the exhibition was vastly amusing, but, after all the guffaw was over, a sad after-thought necessarily came to every thinking man as to the condition of the great metropolis which allowed all its dearest material interests to be placed in such hands as this. It may be said that this was the result of a political system, but it was not. Had there been a tithe of the instruction which should have prevailed—of that simple knowledge that should have existed on this subject—such a thing would have been impossible, no matter what the political exigencies or arrangements were.

So much for the need of popular enlightenment on this subject. Look, now, at a higher range. It is only a few years since the country was startled by the outbreak of a malignant type of fever in one of the leading boarding-schools in New England. The result was, that several ladies from the most respectable families in the country lost their lives. The school had always been considered an admirable one. It was under the charge of a principal and instructors in every way worthy of their calling; but an investigation by competent persons showed that causes of zymotic disease lurked at every corner of the edifice, and that the only wonder was that the disease had not come earlier and spread even wider.

Look now at the want of special and technical instruction. It is little over ten years since the International Commission on Quarantine Matters sat in Paris. They did a great and noble work, but their labors have taken no such hold upon the policy of various States as they ought to have taken. What is the reason of this? There are admirable sanitarians in our own country and in others. We have several of whom the country may justly be proud; but the difficulty is, that our institutions have not given us enough of them to create and spread a healthy public opinion on this subject. One or two, or half a dozen, cannot, in so great a country as this, accomplish so great a work, and especially they cannot if they are burdened with the laborious duty of a metropolitan physician. There is a great want of special instruction in our medical colleges in public hygiene—hygiene in its relation to quarantine matters, in regard to the prevention of epidemics, in regard to sanitary provision for the wants of great cities and districts. Again, if you go into any of our interior States, you will find that any thing like a thorough or carefully-thought-out or wrought-out system of sewerage is a very rare exception to a very wide-spread rule. Nothing can be more inadequate than the system of sewerage of nine-tenths of our cities; and, indeed, until recently, the city of New York, with all its magnificent provision of water-supply, and in spite of its splendid position for drainage, was very improperly provided for in this respect. So much for the want of these different branches of instruction in this great science, and now as to the remedy which I would propose.

First, as regards Public Schools, I would make provision for simple

instruction in the elements of Physiology and Hygiene, either by the use of some short and plain text-book, or, what is still better, by lectures from some competent resident physician. I confess that I greatly prefer the latter method. Not only theory, but experience, leads me to prefer it. Were it not that we have made a very great mistake in our systems of public instruction, by severing our common-school instruction from advanced instruction, we should by this time have a body of teachers in our common schools abundantly able to lecture to the pupils without a text-book. I trust the time will come when provision will be made just as thoroughly for advanced instruction as for primary and common-school instruction, when all will be connected together; when the present illogical separation that exists, under which primary and common-school education is provided for by the State, and advanced education is left very inadequately provided by various religious denominations, will be done away with. But at present we have comparatively few teachers in our public schools who are competent, without text-books, to teach a subject of this kind; therefore it is that I would have provision made, in our larger schools especially, for lectures by resident physicians. That the interest of pupils can be roused in this way I know, for I have seen it fully tried. It is one of those subjects in which, with a little care, the great body of school-children can be greatly interested, and this without the slightest detriment to other subjects. The very change of method will make them come back to other subjects of study with renewed vigor.

Next, as to instruction in our Colleges and Universities. I would have instruction in physiology and hygiene more advanced, systematic, and thorough. Those who have read Herbert Spencer's work on "Education," no matter what they may think of some minor ideas, must have been greatly struck by that part in which he gives his estimate of the comparative value of different branches of knowledge. Among those which should be placed first he names Human Physiology. The reason is very simple. Human Physiology is simply the study of a machine which we are to run, nay, which is to run us for three-score years and ten. Certainly it is a study which falls very directly to us. The study of hygiene naturally comes in connection with it, and it was in obedience to this idea that, in framing the general course of instruction for the Cornell University, careful provision for physiology and hygiene was made. An extensive series of models was purchased, diagrams from Paris and London were obtained, and what was far better, a young professor, who had already begun to obtain a reputation not only as a close investigator, but as an impressive lecturer, was set at the work. The result has been most satisfactory. I am persuaded that study of this kind forms an admirable relief from other studies, pursued in a different way, and for a different purpose. In this case, the study of Physiology and Hygiene has been made very thorough. Frequent and close examinations have been demanded,

and it has been made not merely a study for information, but a study for discipline. And here let me say that, as a starting-point for scientific studies, the study of Hygiene and of Sanitary Science seems to me to have great value. It is not, perhaps, the best point theoretically from which to start, but practically it has been found to be as good as any other.

Next, as to instruction in our Medical Colleges, I speak here with great diffidence, for there are those about me more competent to discourse on this subject than I am. I am well aware that all the effective knowledge that is given to sanitary science in the country, so far as its advanced branches are concerned, is now given in the medical colleges. But it seems to me that not yet is sufficient place given for good instruction in Public Hygiene—sufficient study of that kind which gives to town authorities, county authorities, State authorities, the national authority, a body of experts who can be relied upon in various public emergencies, or, indeed, for ordinary care of public health.

Next, as to instruction in Departments of Engineering, and in our Scientific, Polytechnic, and Technological institutions. Within the past twenty-five years there has been created a science of Sanitary Engineering. I say within the past twenty-five years, although I know that engineering, even in ancient times, had frequent reference to sanitary considerations. Any one who has walked along the Tiber at Rome, as far as the mouth of the Cloaca Maxima, is well aware of that; but it is within the past twenty-five years that the science has been placed on solid foundations. Vital statistics have shown the effects of the introduction of sunlight, of pure water, and air, into our dwellings and cities, and engineering has shown us the best methods of introducing them. Any one who will take up the recent work on this subject by Mr. Baldwin Latham will see what great conquest has here been made. The statistics show that, of seven leading towns and districts in England, such as Croydon, Ely, Salisbury, and others, where careful and thorough modes of sewerage prevail, the percentage of deaths has been reduced from forty to twenty per cent. I also see, from calculations made on the basis of Dr. Allen's tables, that there is a saving to these districts pecuniarily. Taking into view the fact that, for every death prevented, about twenty cases of disease are prevented, I will say that, judged even from a cold financial point of view, the result has been magnificent. What the result would be by good modes of sanitary engineering may be judged from the statement in Dr. Lionel Beales's book on "Disease Germs," which is, that by a good system of sewerage 100,000 lives might be saved annually in England.

But I am aware of the opposition that will be made to any attempt to introduce these studies. First, it will be said that there is little material in this subject for advanced instruction, and that we know

very little regarding the causes or the nature of diseases. That is partly true and partly not true. Unquestionably, the true theory of disease is yet to be wrought out, although every thing leads us to suppose that science is at last upon the right track; but, unquestionably, in relation to the germ of disease, great conquests are yet to be made, and it is a matter of great satisfaction to me, and, I doubt not, to all of you, that one of the most careful of American investigators is to speak on that subject this evening.<sup>1</sup> So, too, the relations of ozone to various diseases is a matter in which conquests are still to be made. There are multitudes of questions yet to be solved, but still many have been solved already. And a very great conquest was made when it was found that zymotic diseases had relation to physical causes, and that the causes were ascertainable and removable. So, too, we have made conquests, as I have stated already, in sanitary engineering. There is material for study. We have made great advances in the study of vital statistics—there is another object of study. I think that this objection, feeble as it is at present, should rapidly become more feeble as science advances, and it can have but little weight among thoughtful men.

But there is another class of objections which are more constantly made—the same objections that have been made to every change in the curriculum of study, from the days of Erasmus until now, and to any liberty in the choice of studies. Those objections are on the score of Discipline and Culture. I remember once that, when this objection was made in the presence of the late Horace Greeley, he cried out, “Discipline! I hate the word.” Nor was this exclamation unnatural. Few words have done more harm to the progress of education than this. I am the last to say any thing against what is now known as the older system of education, or of classical education in general. I prize it; I love it; but, if there were no other argument to show that it is by no means the only mode of discipline or study, the return made by the Commissioners of the English Government, after their examination of the English public schools, is certainly proof on this point. It is there shown that seventy per cent. of the students under the old system, carried out as it is to its very highest point, failed to make any worthy use of their advantage.

What are disciplinary studies? I maintain simply that they are those which for any reason whatever a man takes hold of, and which take hold of him. It matters not whether the study be in obedience to natural tastes, or whether it be forced upon the student. This is the thing—that the study be taken hold of, and that it take hold of the mind of the person studying. Now, in our primary instruction, the studies which I here advocate take hold of great numbers of pupils; take hold of them by virtue of their being a relief from other

<sup>1</sup> President Barnard, of Columbia College, presented a paper on “The Germ Theory of Disease in its Relations to Hygiene.”

studies—by virtue of their appealing to natural objects. Any teacher will bear me out in saying that, as regards pupils of an early age, there is no difficulty in this respect. As regards colleges and universities, there are but two things on which we can rely to make studies take hold upon the minds of students, and to receive thorough attention. The first is, love for them on the part of the student. The other is, their value to the student as regards his direct aims and purposes in life. We cannot in colleges and universities do what was formerly done in England—take the student and whip him. We have to trust to one or the other of these two classes of incentives. Now, the number is considerable of those who, from one motive or the other, would take up this great subject of study. All would not do it; the majority, probably, would not do it; but, if an opportunity were offered, I am satisfied that from every college and every university would go out a body of men not only well instructed in the great principles which underlie sanitary matters, but well disciplined in the obtaining of such instruction.

And now, as to the other branch of the objection—the objection on the score of Culture.

I prize all literary study as highly as any person ought, but yet I maintain that there is, after all, a higher culture. The very ideal, the very god of literary culture, is Goethe; and yet, splendid as he was, there is a higher culture which he lacked, even from a purely earthly point of view. I maintain that, in the studies I now urge, there comes a culture of high purpose, a culture of thought for our fellow-men, a culture involving the idea of duty, which certainly is worth any other sort of culture.

And, if any one objects that these studies are based upon Physiology, which has led man into dangerous paths, that it is, in fact, an unsafe study, I would simply point to these words, uttered so long ago, and from which, certainly, these objectors will make no appeal: "The fear of the Lord is the beginning of wisdom." There is a great truth in these words. We all feel them. But what is that truth? what is that fear? Is it the mere selfish fear which the African native feels for the madness of his fetish? Is it the mere groveling fear which the Turkish slave feels for the tyranny of the satrap placed over him? Certainly not. The only wholesome fear is that fear based not on mystic dread of tyranny, but fear to violate those great laws by which the Divine power which maintains and regulates this universe governs all. That is the fear which lies at the beginning of wisdom, and among those studies, calculated to impress upon us the existence of laws, the violation of which is followed by penalties strictly imposed, stand foremost those to which this Association is now so worthily devoting its attention—studies sure to make the earth more beautiful; sure to make mankind more reverent and noble.

THE DISSIPATION OF ENERGY.<sup>1</sup>

BY H. F. WALLING.

THE dissipation of energy is a continuous process, quite familiar to mankind in its main features and results, since the days of the ancient philosophers. It was recognized by them that all mechanical motions, being dissipated by friction, gradually diminish, and must finally cease unless maintained by external power. In the language of modern science, the motion which thus disappears is converted from molar into molecular motion.

It may be added that molecular energy, existing mainly in the form called heat, tends to equalization of dynamic equilibrium, after the attainment of which it is powerless to produce molar or mechanical motion, a reconversion from the condition of equilibrium being impossible.

Accordingly, the power to produce mechanical motion, exerted by the heat of the sun, which is being lavished with such prodigious prodigality, can only last while the sun continues to be hotter than the other bodies in space. At present it is well understood that all terrestrial motive power is derived from this source with the single unimportant exception of that obtained from the tides, at the expense of the earth's energy of rotation. Among the more obvious processes of conversion of the sun's molecular into terrestrial molar motion, are the expansion and contraction of the atmosphere, the evaporation and condensation of water, and the less direct method by restoration of potential chemical energy accomplished in vegetation, whence are produced food and fuel.

But it is supposed that the sun will finally grow cold, and that the resistance of the ethereal medium, the evidence of whose existence is found in the demonstration of the undulatory theory of light, will cause satellites to fall into planets, planets into suns, and suns into one common centre, after which, unless by special interposition of divine power, darkness, silence, and death, will forever prevail.

This gloomy prediction is of course inconsistent with the theory of continuous evolution, which obviously excludes from cosmical economy catastrophes or extensive destructive effects.

A careful consideration, however, of the circumstances which will be likely to accompany the falling of a satellite into its planet may lead to the conclusion that this occurrence will not necessarily be catastrophic. The process must certainly be an exceedingly *slow* one, no progress in it having been detected throughout all the recorded observations of the moon's motion extending over thousands of years.

<sup>1</sup> The Relation of the Dissipation of Energy to Cosmical Evolution. Read at the Portland meeting of the American Association for the Advancement of Science.



The only practical evidence which has been adduced to prove the resistance of a medium, namely, a very slight diminution in the period of that nearly evanescent body, Encke's Comet, is very far from being definite and satisfactory. The mass of the moon being enormously greater, it is probable that many millions of years will pass before a diminution of her orbital period from this cause will be perceptible. The immense periods of time attributed to the past processes of geological evolution, and to the supposed metamorphoses of organic life, are therefore very brief when compared with those required for the returns of satellites to their parent orbs, admitting, as theoretical considerations seem to require, that such returns are ultimately inevitable.

The eccentricity being diminished by the resistance of a medium, the moon's orbit would eventually become, and afterward continue, circular, so that final contact would be unaccompanied by violent collision. But, before the time of actual contact, changes of form would be induced both in planet and satellite by mutual attractions, exemplified in the production of daily terrestrial *tides*. The investigations of Hopkins, Thomson, and recently of Barnard, in regard to tidal and precessional influences, indicate that, even at the present distance of the moon, they must cause elongations and contractions of the solid materials of the earth, which are quite appreciable. A considerable diminution of the distance between the earth and moon would give rise to changes in the form of the earth, and hence to bendings to and fro of its external shell even if the earth were solid throughout. This would be accompanied by earthquakes and kindred disturbances far exceeding in magnitude and destructiveness any thing of the kind now known to man. The frequency of these occurrences would be the same as that of the moon's meridian passage.

Resistances to this tidal action, however, would be developed, in consequence of which the molar motion of rotation would be converted into molecular motion, so long as the angular motion of rotation in either body was different from that of the moon's revolution, until the rotations became synchronous with the revolution, a condition already arrived at in the case of the moon. Synchronism once attained would be permanent, acceleration both of revolution and rotation occurring as the distance diminished, and both at the expense of the potential energy of gravity between the two bodies. Each body presenting the same face to the other, no meridian passage could take place, and hence no tidal action.

But there yet remains to be considered a continually increasing tendency to distortion of form consequent upon approach. This effect would be produced very gradually, being spread over such enormous durations of time. The curious and complicated foldings of the rocks in the Appalachian regions indicate that the solid materials of the earth are sufficiently plastic to allow it to take on any form toward which forces of sufficient magnitude direct it, provided the times be

very greatly extended. Hence, considering the extreme slowness of the process, it may be reasonable to conclude that the forms ultimately developed would be identical with those which would be assumed by liquid masses having the same relative positions and velocities.

The determination of these forms is a problem for the mathematicians. In the absence of analysis, no reason is manifest for supposing that the forms of equilibrium would be materially different just before and just after contact. May it not be that the order of change would be a partial reversal of certain supposed processes of the nebular hypothesis? Thus the moon may be gradually elongated into a closed ring which will slowly contract upon the earth as the energy of angular velocity is gradually dissipated by the friction of the medium. In any event there seems to be no good reason to suppose that there will be such a sudden leap in the final osculation or embrace as would result in a catastrophe.

The same considerations apply to the gravitational relations between planets and suns. Other very important relations between these bodies, however, with which organic life is more especially concerned, require attention. One fundamental requisite to all known terrestrial organic life is the conversion, within living bodies, of molecular energy, either into molar motions, or into potential energy which may afterward be thus converted. All living animals and plants, therefore, depend for their existence upon the passage through their bodies, in the movement toward distribution and equalization, of heat, light, and other molecular forces originating in the sun.

The integrity of cosmical evolution in relation to organic life, accordingly, seems to require the maintenance of great central laboratories where molecular disturbances of sufficient intensity and quantity can be continually generated, and their effects distributed throughout the universe. Notwithstanding the enormous expenditure of heat by the sun, its temperature is supposed to have been maintained about the same as at present for a very long period of time in the past, and no reason is manifest why this fixed temperature will not continue for a very long time in the future. Doubtless, operations are going on in the sun which it would be impossible to imitate in terrestrial laboratories. May it not be that the conditions of materials and the circumstances of pressure, chemical affinity, etc., are such, that substances more elementary than our so-called chemical elements are uniting with an energy far exceeding that of any chemical combination we can effect, and so prodigious as to maintain, at comparatively small expenditure of material, the sun's temperature at that enormous degree which marks the *dissociation* point of the tremendously energetic combination? The duration of the combination or combustion would thus be prolonged to an enormously remote period. At last, when all the potential energy due to this particular reaction became exhausted by the combination of all

the special materials required for it, new materials, whose dissociation point had a lower temperature, and which had consequently been prevented from combining previously, would commence upon a similar process of combustion. And so we may suppose combination to follow combination, until, finally, perhaps at a time when the planets, freighted with their living inhabitants, have begun to arrive at the sun's surface, long after the fires of the last combustion have expired, it has itself become a habitable globe, lighted and heated or served by other molecular forces from distant orbs where new conditions cause new chemical combinations, and conversions of newly-developed potential energies.

Finally, giving play to the imagination, may we not suppose further, that, in a universe extended throughout infinite space, processes of concentration similar to those supposed in the nebular hypothesis and supplemented by processes like those here indicated will go on forever, evolving worlds of continually-increasing magnificence, perhaps inhabited by living occupants of inconceivably transcendent and ever-expanding faculties?

---

## NEWS FROM JUPITER.

BY RICHARD A. PROCTOR, B. A.

THE planet Jupiter has passed during the last year through a singular process of change. The planet has not, indeed, assumed a new appearance, but has gradually resumed its normal aspect after three or four years, during which the mid zone of Jupiter has been aglow with a peculiar ruddy light. The zone is now of a creamy-white color, its ordinary hue. We have, in fact, reached the close of a period of disturbance, and have received a definite answer to questions which had arisen as to the reality of the change described by observers. Many astronomers of repute were disposed to believe that the peculiarities recently observed were merely due to the instruments with which the planet has been observed—not, indeed, to any fault in those instruments, but, in fact, to their good qualities in showing color. A considerable number of the earlier accounts of Jupiter's change of aspect came from observers who used the comparatively modern form of telescope known as the silvered-glass reflectors, and it is well known that these instruments are particularly well suited for the study of color-changes. Nevertheless, observations made with the ordinary refracting telescope were not wanting; and it had begun to be recognized that Jupiter really had altered remarkably in appearance, even before that gradual process of change which, by restoring his usual aspect, enabled every telescopist to assure himself that there had been no illusion in the earlier observations.

I propose now to discuss certain considerations which appear to me to indicate the nature and probable meaning of the phenomena which have recently been observed in Jupiter. It seems to me that these phenomena are full of interest, whether considered in themselves or in connection with those circumstances on which I had been led to base the theory that Jupiter is a planet altogether unlike our earth in condition, and certainly unfit to be the abode of living creatures.

I would first direct special attention to the facts which have been ascertained respecting the atmosphere of Jupiter.

It does not appear to have been noticed as a remarkable circumstance, that Jupiter should have an atmosphere recognizable from our distant station. Yet, in reality, this circumstance is not only most remarkable, but is positively inexplicable on any theory by which Jupiter is regarded as a world resembling our own. It is certain that, except by the effects produced when clouds form and dissipate, our terrestrial atmosphere could not be recognized at Jupiter's distance with any telescopic power yet applied. But no one who has studied Jupiter with adequate means can for a moment fail to recognize the fact that the signs of an atmosphere indicate much more than the mere formation and dissipation of clouds. I speak here after a careful study of the planet during the late opposition, with a very fine reflecting telescope by Browning, very generously placed at my disposal by Lord Lindsay; and I feel satisfied that no one can study Jupiter for many hours (on a single night) without becoming convinced that the cloud-masses seen on his disk have a *depth* comparable with their length and breadth. Now, the depth of terrestrial cloud-masses would at Jupiter's distance be an absolutely evanescent quantity. The span of his disk represents about 84,000 miles, and his satellites, which look little more than points in ordinary telescopes, are all more than 2,000 miles in diameter. I am satisfied that any one who has carefully studied the behavior of Jupiter's cloud-belts will find it difficult to believe that their depth is less than the twentieth part of the diameter of the least satellite. Conceive, however, what the depth of an atmosphere would be in which cloud-masses a hundred miles deep were floating!

It may be asked, however, in what sense such an atmosphere would be inexplicable, or, at least irreconcilable with the theory that Jupiter is a world like our earth. Such an atmosphere would be in strict proportion, it might be urged, to the giant bulk of the planet, and such relative agreement seems more natural than would be a perfect correspondence between the depth of the atmosphere on Jupiter and the depth of our earth's atmosphere.

But it must not be forgotten that the atmosphere of Jupiter is attracted by the mass of the planet; and some rather remarkable consequences follow when we pay attention to this consideration. Of course a great deal must be assumed in an inquiry of the sort. Since, however, we are discussing the question whether there can be any re-

semblance between Jupiter and our earth, we may safely (so far as our inquiry is concerned) proceed on the assumption that the atmosphere of Jupiter does not differ greatly in constitution from that of our earth. We may further assume that, at the upper part of the cloud-layers we see, the atmospheric pressure is not inferior to that of our atmosphere at a height of seven miles above the sea-level, or one-fourth of the pressure at our sea-level. Combining these assumptions with the conclusion just mentioned, that the cloud-layers are at least 100 miles in depth, we are led to the following singular result as to the pressure of the Jovian atmosphere at the bottom of the cloud-layer: The atmosphere of any planet doubles in pressure with descent through equal distances, these distances depending on the power of gravity at the planet's surface. In the case of our earth, the pressure is doubled with descent through about  $3\frac{1}{2}$  miles; but gravity on Jupiter is more than  $2\frac{1}{2}$  times as great as gravity on our earth, and descent through  $1\frac{2}{5}$  mile would double the pressure in the case of a Jovian atmosphere. Now, 100 miles contain this distance ( $1\frac{2}{5}$  mile) more than seventy-one times; and we must therefore double the pressure at the upper part of the cloud-layer seventy-one successive times to obtain the pressure at the lower part. Two doublings raise the pressure to that at our sea-level; and the remaining sixty-nine doublings would result in a pressure exceeding that at our sea-level so many times that the number representing the proportion contains twenty-one figures.<sup>1</sup> I say *would* result in such a pressure, because in reality there are limits beyond which atmospheric pressure cannot be increased without changing the compressed air into the liquid form. What those limits are we do not know, for no pressure yet applied has changed common air, or either of its chief constituent gases, into the liquid form, or even produced any trace of a tendency to assume that form. But it is easily shown that there must be a limit to the increase of pressure which air will sustain without liquefying. For the density of any gas changes proportionately to the increase of pressure until the gas is approaching the state when it is about to turn liquid. Now, air at the sea-level has a density equal to less than the 900th part of the density of water; so that, if the pressure at the sea-level were increased 900 times, either the density would not increase proportionally, which would show that the gas was approaching the density of liquefaction, *or else* the gas would be denser than water, which must be regarded as utterly impos-

<sup>1</sup> The problem is like the well-known one relating to the price of a horse, where one farthing was to be paid for the first nail of 24 in the shoes, a half-penny for the next, a penny for the third, two pence for the fourth, and so on. It may be interesting to some of my readers to learn, that if we want to know roughly the proportion in which the first number is increased by any given number of doublings, we have only to multiply the number of doublings by  $\frac{1}{10}$ ths, and add 1 to the integral part of the result, to give the number of digits in the number representing the required proportions. Thus multiplying 24 by  $\frac{1}{10}$ ths gives 7 (neglecting fractions); and therefore the number of farthings in the horse problem is represented by an array of 8 digits.

sible. Or, if any one is disposed, for the sake of argument, to assume that a gas (*at ordinary temperatures*) may be as dense as water, then we need proceed but a few steps further, increasing the pressure about 18,000 times instead of 900 times, to have the density of *platinum* instead of that of water, and no one is likely to maintain that our air could exist in the gaseous form with a density equaling that of the densest of the elements. We are still an enormous way behind the number of twenty-one figures mentioned above; and, in fact, if we supposed the pressure and density to increase continually to the extent implied by the number of twenty-one figures, we should have a density exceeding that of platinum more than ten thousand millions of millions of times!

Of course this supposition is utterly monstrous, and I have merely indicated it to show how difficulties crowd around us in any attempt to show that a resemblance exists between the condition of Jupiter and that of our earth. The assumptions I made were sufficiently moderate, be it noticed, since I simply regarded (1) the air of Jupiter as composed like our own; (2) the pressure at the upper part of his cloud-layer as not less than the pressure far above the highest of our terrestrial cumulus clouds (with which alone the clouds of Jupiter are comparable); and (3) the depth of his cloud-layer as about one hundred miles. The first two assumptions cannot fairly be departed from to any considerable extent, without adopting the conclusion that the atmosphere of Jupiter is quite unlike that of our earth, which is precisely what I desire to maintain. The third is, of course, open to attack, though I apprehend that no one who has observed Jupiter with a good telescope will question its justice. But it is not at all essential to the argument that the assumed depth of the Jovian atmosphere should be even nearly so great. We do not need a third of our array of twenty-one figures, or even a seventh part, since no one who has studied the experimental researches made into the condition of gases and vapors can for a moment suppose that an atmosphere like ours could remain gaseous, *except at an enormously high temperature*, at a pressure of two or three hundred atmospheres. Such a pressure would be attained, retaining our first two assumptions, at a depth of about fourteen miles below the upper part of the cloud-layer. This is about the six-thousandth part of the diameter of Jupiter; and, if any student of astronomy can believe that that wonderfully complex and changeable cloud-envelope which surrounds Jupiter has a thickness of less than the six-thousandth part of the planet's diameter, I would recommend as a corrective the careful study of the planet for an hour or two with a powerful telescope, combined with the consideration that the thickness of a spider's web across the telescopic field of view would suffice to hide a breadth of twenty miles on Jupiter's disk.

But we are not by any means limited to the reasoning here indicated, convincing as that reasoning should be to all who have studied



the aspect of Jupiter with adequate telescopic power. We have in Jupiter's mean density an argument of irresistible force against the only view which enables us even hypothetically to escape from the conclusions just indicated. Let it be granted, for the sake of argument, that Jupiter's cloud-layer is *less* than fourteen miles in depth, so that we are freed for the moment from the inference that at the lower part of the atmosphere there is either an intense heat or else a density and pressure incompatible with the gaseous condition. We cannot, in this case, strike off more than twenty-eight miles from the planet's apparent diameter to obtain the real diameter of his solid globe—solid, at least, if we are to maintain the theory of his resemblance to our earth. This leaves his real diameter appreciably the same as his apparent diameter, and as a result we have the mean density of his solid globe equal to a fourth of the earth's mean density, precisely as when we leave his atmosphere out of the question. Now, I apprehend that the time has long since passed when we can seriously proceed at this stage to say, as it was the fashion to say in text-books of astronomy, "Therefore the substance of which Jupiter is composed must be of less specific gravity than oak and other heavy woods." We know that Brewster gravely reasoned that the solid materials of Jupiter might be of the nature of pumice-stone, so that, with oceans resembling ours, a certain latitude was allowed for increase of density in Jupiter's interior. But, in the presence of the teachings of spectroscopic analysis, few would now care to maintain, as probable, so preposterous a theory as this. Every thing that has hitherto been learned, respecting the constitution of the heavenly bodies, renders it quite unlikely that the elementary constitution of Jupiter differs from that of our earth. Again, it was formerly customary to speak of the possibility that Jupiter and Saturn might be hollow globes, mere shells, composed of materials as heavy as terrestrial elements. But, whatever opinion we may form as to the possibility that a great intensity of heat may vaporize a portion of Jupiter's interior, we know quite certainly that there must be enormous pressure throughout the whole of the planet's globe, and that even a vaporous nucleus would be of great density. For it is to be remembered that all that I have said above respecting the possibility of gases existing at great pressures applies only to ordinary temperatures—such temperatures, for example, as living creatures can endure. At exceedingly high temperatures much greater pressure, and therefore much greater density, can be attained without liquefaction or solidification. And, in considering the effect of pressure on the materials of a solid globe, we must not fall into the mistake of supposing that the strength of such solid materials can protect the material from compression and its effects. We must extend our conceptions beyond what is familiar to us. We know that any ordinary mass of some strong, heavy solid—as iron, copper, or gold—is not affected by its own weight so as to change in structure to

an appreciable extent. The substance of a mass of iron forty or fifty feet high, would be the same in structure at the bottom as at the top of the mass; for the strength of the metal would resist any change which the weight of the mass would (otherwise) tend to produce. But if there were a cubical mountain of iron twenty miles high, the lower part would be absolutely plastic under the pressure to which it would be subjected. It would behave in all respects as a fluid, inasmuch that if (for convenience of illustration) we suppose it inclosed within walls made of some imaginary (and impossible) substance which would yield to no pressure, then, if a portion of the wall were removed near the base of the iron mountain, the iron would flow out like water<sup>1</sup> from a hole near the bottom of a cask. The iron would continue to run out in this way, until the mass was reduced several miles in height. In Jupiter's case a mountain of iron of much less height would be similarly plastic in its lower parts, simply because of the much greater attractive power of Jupiter's mass. Thus we see that the conception of a hollow interior, or of any hollow spaces throughout the planet's globe, is altogether inconsistent with what is known of the constitution of even the strongest materials.

How, then, are we to explain the relatively small mean density of Jupiter's globe? On the supposition that his atmosphere is less than fourteen miles deep, we cannot do so; for there is nothing hypothetical in the above considerations respecting a solid globe as large as Jupiter's, excepting always the assumption that the globe is not formed of substances unlike any with which we are familiar. Even this assumption, though it is one which few would care to maintain in the present position of our knowledge, amounts after all to an admission of the chief point which I am endeavoring to maintain: it is one way—but a very fanciful way—of inferring that Jupiter is utterly dissimilar to the earth. Rejecting it, as we safely may, we find the small density of Jupiter not merely unexplained, but manifestly inexplicable.

All our reasoning has been based on the assumption that the atmosphere of Jupiter exists at a temperature not greatly differing from that of our own atmosphere. If we assume instead an exceedingly high temperature, abandoning of course the supposition that Jupiter is an inhabited world, we no longer find any circumstances which are self-contradictory or incredible.

To begin with, we may on such an assumption find at once a parallel to Jupiter's case in that of the sun. For the sun is an orb attracting his atmospheric envelope and the material of his own solid or liquid surface (if he has any) far more mightily than Jupiter has been known to do. All the difficulties considered in the case of Jupiter would be enormously enhanced in the case of the sun, if we forgot the fact that the sun's globe is at an intense heat from surface to cen-

<sup>1</sup> The effect of pressure in rendering iron and other metals plastic has been experimentally determined. Cast-steel has been made to flow almost like water, under pressure.

tre. Now, we know that the sun is intensely hot because we feel the heat that he emits, and recognize the intense lustre of his photosphere; so that we are not in danger of overlooking this important circumstance in his condition. Jupiter gives out no heat that we can feel, and assuredly Jupiter does not emit an intense light of his own. But, when we find that difficulties, precisely corresponding in kind, though not in degree, to those which we should encounter if we discussed the sun's condition in forgetfulness of his intense heat, exist also in the case of Jupiter, it appears manifest that we may safely adopt the conclusion that Jupiter is intensely heated, though not nearly to the same degree as the sun.

We have thus been led by a perfectly distinct and independent line of reasoning to the very conclusion which I have advocated elsewhere on other grounds, viz., that Jupiter is in fact a miniature sun as respects heat, though emitting but a relatively small proportion of light. I would invite special attention to the circumstance that the evidence on which this conclusion had been based was already cumulative. And now a fresh line of evidence, in itself demonstrative I conceive, has been adduced. Moreover, I have not availed myself of the argument, very weighty in my opinion, on which Mr. Mattieu Williams has based similar conclusions respecting the temperature of Jupiter, in his interesting and valuable work called "The Fuel of the Sun." I fully agree with him in regarding it as a reasonable assumption, though I cannot go so far as to regard it as certain, that every planet has an atmosphere whose mass corresponds with, or is even perhaps actually proportional to, the mass of the planet it surrounds. If we make such an assumption in the case of Jupiter, we arrive at conclusions closely resembling those to which I have been led by the above process of reasoning.

Thus many lines of evidence, and some of them absolutely demonstrative, in my opinion, point to the conclusion that Jupiter is an orb instinct with fiery energy, aglow it may well be with an intense light which is only prevented from manifesting itself by the cloudy envelope which enshrouds the planet.

But, so soon as we regard the actual phenomena presented by Jupiter in the light of this hypothesis, we find the means of readily interpreting what otherwise would appear most perplexing. Chief among the phenomena thus accounted for, I would place the recent color-changes in the equatorial zone of Jupiter.

What, at a first view, could appear more surprising than a change affecting the color of a zone-shaped region whose surface is many times greater than the whole surface of our earth. It is true that a brief change might be readily explained as due to such changes as occur in our own air. Large regions of the earth are at one time cloud-covered, and at another free from clouds. Such regions, seen from Venus or Mercury, would at one time appear white, and at the other would

show whatever color the actual surface of the ground might possess when viewed as a whole. But it seems altogether impossible to explain in this way a change or series of changes occupying many years, as in the case of the recent color-changes of Jupiter's belt. Let me not be misunderstood. I am not urging that the changes in Jupiter are *not* due to the formation and dissipation of clouds in his atmosphere. On the contrary, I believe that they are. What seems to me incredible is, the supposition that we have here to deal with such changes as occur in our own air in consequence of solar action.

I do not lose sight of the fact that the Jovian year is of long duration, and that whatever changes take place in the atmosphere of Jupiter through solar action might be expected to be exceedingly slow. Nay, it is one of the strongest arguments against the theory that solar action is chiefly in question, that any solar changes would be so slight as to be in effect scarcely perceptible. It is not commonly insisted upon in our text-books of astronomy—in fact, I have never seen the point properly noticed anywhere—that the seasonal changes in Jupiter correspond to no greater *relative* change than occurs in our daily supply of solar heat from about eight days before to about eight days after the spring or autumn equinox. It is incredible that so slight an effect as this should produce those amazing changes in the condition of the Jovian atmosphere which have unquestionably been indicated by the varying aspect of the equatorial zone. It is manifest that, on the one hand, the seasonal changes should be slow and slight so far as they depend on the sun, and, on the other, that the sun cannot rule so absolutely over the Jovian atmosphere as to cause any particular atmospheric condition to prevail unchanged for years.

If, however, Jupiter's whole mass is in a state of intense heat—if the heat is in fact sufficient, as it must be, to maintain an effective resistance against the tremendous force of Jovian gravitation—we can understand any changes, however amazing. We can see how enormous quantities of vapor must continually be generated in the lower regions to be condensed in the upper regions, either directly above the zone in which they were generated, or north or south of it, according to the prevailing motions in the Jovian atmosphere. And, although we may not be able to indicate the precise reason why at one time the mid zone or any other belt of Jupiter's surface should exhibit that whiteness which indicates the presence of clouds, and at another should show a coloring which appears to indicate that the glowing mass below is partly disclosed, we remember that the difficulty corresponds in character to that which is presented by the phenomena of solar spots. We cannot tell why sun-spots should wax and wane in frequency during a period of about eleven years; but this does not prevent us from adopting such opinions as to the condition of the sun's glowing photosphere as are suggested by the behavior of the spots.

It may be asked whether I regard the ruddy glow of Jupiter's equatorial zone, during the period of disturbance lately passed through, as due to the inherent light of glowing matter underneath his deep and cloud-laden atmosphere. This appears to me on the whole the most probable hypothesis, though it is by no means certain that the ruddy color may not be due to the actual constitution of the planet's vaporous atmosphere. In either case, be it noted, we should perceive in this ruddy light the inherent lustre of Jupiter's glowing mass, only in one case we assume that that lustre is itself ruddy, in the other we suppose that light, originally white, shines through ruddy vapor-masses. It is to be remembered, however, that, whichever view we adopt, we must assume that a considerable portion of the light received, even from these portions of the planet's disk, must have been reflected sunlight. In fact, from what we know about the actual quantity of light received from Jupiter, we may be quite certain that no very large portion of that light is inherent. Jupiter shines about as brightly as if he were a giant cumulus-cloud, and therefore almost as white as driven snow. Thus he sends us much more light than a globe of equal size of sandstone, or granite, or any known kind of earth. We get from him about three times as much light as a globe like our moon in substance, but as large as Jupiter, and placed where Jupiter is, would reflect toward the earth; but not quite so much as we should receive from a globe of pure snow of the same size and similarly placed. It is only because large parts of the surface of Jupiter are manifestly *not* white, that we seem compelled to assume that some portion of his light is inherent. But the theory that Jupiter is intensely hot by no means requires, as some mistakenly imagine, that he should give out a large proportion of light. His real solid or liquid globe (if he have any) might, for instance, be at a white heat, and yet so completely cloud-enwrapped that none of its light could reach us. Or, again, his real surface might be like red-hot iron, giving out much heat but very little light.

I shall close the present statement of evidence in favor of what I begin to regard as in effect a demonstrated theory, with the account of certain appearances which have been presented by Jupiter's fourth satellite during recent transits across the face of the planet. The appearances referred to have been observed by several telescopists, but I will select an account given in the monthly notices of the Astronomical Society, by Mr. Roberts, F. R. A. S., who observed the planet with a fine telescope by Wray, eight inches in aperture. "On March 26, 1873," he says, "I observed Jupiter about 8 p. m., and found the fourth satellite on the disk. I thought at first it must be a shadow; but, on referring to the *Nautical Almanac*, found that it was the fourth satellite itself. A friend was observing with me, and we both agreed that it was a very intense black, and also was not quite round. We each made independent drawings, which agreed perfectly, and consider that the observation was a perfectly reliable one. We could

not imagine that such an intensely black object would be visible when off the disk, and waited with some impatience to see the emersion, but were disappointed by fog, which came on just at the critical time." Another observer, using a telescope only two inches in aperture, saw the satellite when off the disk, so that manifestly the blackness was merely an effect of contrast.

In considering this remarkable phenomenon, we must not forget that the other satellites do not look black (though some of them look dark) when crossing Jupiter's disk, so that we have to deal with a circumstance peculiar to the fourth or outermost satellite. Nevertheless, we seem precluded from supposing that any other difference exists between this satellite and the others than a certain inferiority of light-reflecting power. I might indeed find an argument for the view which I have suggested as not improbable, that Jupiter is a heat-sun to his satellites, since the three innermost would be in that case much better warmed than the outermost, and therefore would be much more likely to be cloud-encompassed, and so would reflect more light. But I place no great reliance on reasoning so ingenious, which stands much as a pyramid would stand (theoretically) on its apex. The broad fact that a body like the fourth satellite, probably comparable to our moon in light-reflecting power, looks perfectly black when on the middle of Jupiter's disk, is that on which I place reliance. This manifestly indicates a remarkable difference between the brightness of Jupiter and the satellite; and it is clear that the excess of Jupiter's brightness is in accordance with the theory that he shines in part with native light, or, in other words, is intensely heated.

This completes the statement of the evidence obtained during the recent opposition of Jupiter in favor of a theory which already had the great advantage of according with all known facts, and accounting for some which had hitherto seemed inexplicable. If this theory removes Jupiter from the position assigned to him by Brewster as the noblest of inhabited worlds, it indicates for him a higher position as a subordinate sun, nourishing with his heat, as he sways by his attractive energy, the scheme of worlds which circles round him. The theory removes also the difficulty suggested by the apparent uselessness of the Jovian satellites in the scheme of creation. When, instead of considering their small power of supplying Jupiter with light, we consider the power which, owing to his great size and proximity, he must possess of illuminating them with reflected light, and warming them with his native heat, we find a harmony and beauty in the Jovian system which before had been wanting; nor, when we consider the office which the sun subserves toward the members of his family, need we reject this view on account of the supposition—

"That bodies bright and greater should not serve  
The less not bright."

—*Popular Science Review.*



## THE SPANG COLLECTION OF MINERALS.

BY ALBERT R. LEEDS,

PROFESSOR OF CHEMISTRY IN THE STEVENS POLYTECHNIC INSTITUTE.

THE increasing taste for the pursuit of natural science in this country is strikingly exhibited by the rapid increase in the number of gem and mineral collections. The taste is not confined to men of any one profession, but is cultivated by lawyers, physicians, artists, engineers, iron-masters and persons in every rank and walk of life. Some of the collections thus formed are valuable in a scientific point of view, on account of their being receptacles for specimens obtained in the prosecution of mining enterprises, or from local discoveries arising in the opening of quarries, the development of farm-lands, or cutting of canals and road-ways; thus preserving material which otherwise would be lost, and which ultimately must be handed over to the skilled mineralogist for accurate description and analysis. Other private collections are of deep interest on account of containing specimens of such exceeding rarity and costliness as to surpass aught that our colleges with their hitherto meagre endowments can display. This is especially true of the magnificent cabinet, some few of whose wonders I desire cursorily to describe in the present sketch, and which, by very general consent, is regarded as one of the finest collections in existence at the present time. This result has been achieved by an unsparing expenditure of money, time, and energy, not only in this country and Europe, but in every part of the world; extending to the sending out of paid collectors, the blasting of rocks in remote mountain-districts, the outbidding of all rivals when cabinets were offered for sale, and an unceasing watch over the fate of every unique specimen known to mineralogists. In some instances entire collections were purchased in order to secure a few remarkable specimens. To the man of science the collection affords the gratification of examining fine specimens of bodies so extremely rare that few persons have ever beheld them. The resources of the cabinet are most generously placed at the disposal of those engaged in any special mineral research; and, finally, the munificent owner proposes eventually to endow some institution of learning in this country with the perfected cabinet.

It is difficult to begin where so many objects worthy of study present themselves, and I shall not attempt a systematic description of this accumulation of minerals, which, though crowded together, can barely find room in eleven cases of drawers, a fire-proof safe and six glass show-cases. In the inclosed cases are more than 300 drawers, averaging about 25 specimens to the drawer.

But in the first place the tourmalines attract our attention. Of

these, a variety found near Gouverneur, in the State of New York, is distinguished by its peculiar brown color and internal structure. There is a suite of at least one hundred specimens of this variety alone, each one having been selected on account of some characteristic difference, and presenting together all the known and probably some yet undescribed crystalline faces. Some of the specimens are aggregates of crystals, one mass displaying fifty distinct terminations; others are individual crystals, frequently doubly terminated and showing the different arrangement of the planes upon the analogous and antilogous poles. The dimensions of one of these single crystals, reputed to be the largest ever found at Gouverneur, deserve a permanent record. It is four inches in height and four and a half inches through, with the rhombohedral faces of one termination almost perfectly developed, and with one rhombohedral face of the other termination four inches in width, the two other corresponding planes having been points of attachment to the rock. It is bounded by eighteen prismatic faces, all of which are perfect in form and polish.

Of the black tourmalines, there is one from Springfield, New Hampshire, which has a termination remarkable for the extreme development of the basal plane. It is  $4\frac{1}{2} \times 3\frac{3}{4}$  inches across, and almost extinguishes the primary rhombohedron. Among entirely unique specimens from Greenland, Bovey Tracey, in Devonshire, England, Haddam, Connecticut, Norway and Sweden, we might mention a group from *Greenland*, of fifty or sixty crystals, mostly doubly terminated, and from four to six inches in length, forming a rosette with divergent crystals.

To the finely colored red tourmalines, which are frequently cut and polished as gems, the name of rubellite is given; those from Siberia being mostly violet red, the Brazilian rose-red; the specimens from Chesterfield and Goshen, Massachusetts, are pale rose-red and opaque; those from Paris, Maine, fine ruby-red. Among these rubellites there are six from Elba, of exquisitely delicate pink-color. They are hexagonal prisms, one of which is one and a quarter inch in height and three quarters of an inch in diameter, all implanted on a base that is itself very beautiful from the contrasted groups of rock-crystal, adular, and rosettes of mica, of which it is made up. Of rubellites from Elba there are more than fifty specimens, some of them reposing upon the native rock; others are terminated detached crystals of various shades of pink—also crystals on the gangue and fine detached rubellites from Siberia. When it is remembered that the slightest imperfection in the sharpness of an edge or angle, the scratching of a single face, excludes a specimen from this cabinet, and that none are admitted which are not at the same time remarkable for size, beauty, and perfection of crystalline form, the brilliant effect of a drawer filled with these natural gems can be imagined.

More than usual interest attaches to the mineral of which I am

now about to speak, the Columbite, on account of the derivation of its name and the history of its discovery. The rare metallic element columbium, or niobium as it has subsequently been called, was first discovered in 1802, by Hatchett, in a specimen of this mineral sent out by Governor Winthrop, of Connecticut, to Sir Hans Sloane, then president of the Royal Society, and the original analysis was made by Wollaston, with an accuracy truly surprising, upon only four grains of the specimen, so long ago as the year 1809. It is highly probable that Governor Winthrop's mineral came from Middletown, Connecticut, at which locality some very large crystals have since been found; among many such in the Spang collection, there is one composed of twenty-five crystals compounded together, and showing the terminal planes at the summit of each crystal. Two of the prismatic faces of one of these crystals are three inches in length.

There is a genus of minerals termed zeolites, from a Greek word signifying *to boil*, for the reason that when heated the large percentage of water which they contain escapes with intumescence, and of these one of the most remarkable species is scolecite, so called because, on touching it with the tip of a blow-pipe flame, it curls up like a worm. I find elsewhere the record of some crystals, which were found in the Beruford, Iceland; and which exceeded two inches in length and were a quarter of an inch thick. There is a radiated mass of scolecite crystals in this collection, brought from Poonah, Hindostan, the largest being three inches in length, and compounded of two twins, each of which is one-quarter of an inch in diameter. The beauty of this group is still further enhanced by clusters of transparent tabular apophyllites attached to the sides of the crystals.

There is another species of zeolite, which, on account of its brilliant, pearly lustre, has received the name of stilbite. Usually its color is white; in this collection there is a specimen of stilbite from Poonah, that is compounded of a great number of individual crystals, the terminations of which together make up an octahedral summit with planes two inches wide. The color is a deep, rich salmon.

Of the apophyllites from the same locality, one of the most beautiful is a tabular square prism with the angles replaced by octahedral planes, all of which are perfect in lustre and surface polish. The crystal measures two and a quarter inches across, and is one and a quarter inch in height. There are remarkable suites of pink apophyllites from the Hartz, transparent green crystals, highly modified, from Nova Scotia, and some of the finest of those crystals which made the Erie tunnel through the trap-rock of Bergen Hill, New Jersey, at one time so famous among mineralogists. It is from such wonderful works as these that we are enabled justly to appreciate the transcendent skill with which Nature performs her task when she tries her hand at the plastic arts; for example, what piece of statuary could be so faultless, in grouping and finish, as one of these specimens,

which consists of thousands of apophyllite crystals, many of them an inch and averaging half an inch in size, festooned about a cluster of pendant stalactites?

Two uncut diamonds of great brilliancy are remarkable for the perfection of their forms; one is an octahedron with dodecahedral planes, the other is an elliptic twin, in shape closely resembling a heart. Each stone is of one carat weight, and entirely limpid and without a flaw—fit, in fact, for setting, though never touched by the lapidary. Less costly, but hardly less beautiful than these, are some Aragonites from Sicily, which are strikingly thrown into relief by the pedestal of lemon-yellow crystals of sulphur upon which they are mounted. They are six-sided prisms, measuring two and a quarter inches along the vertical, and two and a half inches along the lateral axis. Their bases and summits are perfectly plane.

At the time of its purchase and incorporation into the museum of Harvard University, I had the pleasure of critically examining the collection of minerals which had been accumulated by Herr Liebner, a mining-captain in the Tyrol. The finest specimens were a suite of Tyrolese epidotes, and I imagined that Nature could not surpass them, until I saw those in the possession of Mr. Spang. Among others of still larger dimensions, there is one prism of epidote which is eight inches in length, and three-quarters by one half an inch in thickness. It is perfectly straight, and all its sides and terminal planes are of a smoothness and lustre indescribable. The light transmitted through the crystal in one direction is a magnificent ruby-red, almost identical in tint with that exhibited by light-red silver-ore. Another crystal might fairly be entitled a gem of immense size; it is three inches in length, and exhibits thirteen terminal planes. On revolving it into different positions, the light passing through it changes in color from a delicate hair-brown to cherry and then to deep ruby-red.

Before concluding this sketch, some bodies of extreme rarity should be mentioned, among them the chloro-carbonate of lead, termed phosgenite. Most mineralogists are rejoiced to obtain minute crystals of this mineral, the large crystals from Crawford, near Matlock, in Derbyshire, having sold for from fifteen to twenty pounds sterling each. This cabinet contains a perfect prism, of strong adamantine lustre on all its faces, which is one and a half inch in height, one and a quarter broad, and one and an eighth in thickness. Still more rare is a mineral, of which singularly enough we possess as yet no satisfactory analysis, known as Turnerite, from the Tavetsch Valley in the Alps. In this collection there is a number of perfect crystals, five if I remember correctly, each of which displays many highly-lustrous facets, and occurring both isolated and embedded in a rock made up of quartz and albite. The largest crystal is three-quarters of an inch long and five-eighths of an inch thick. It is a doubly-terminated hexagonal prism, the basal edges being regularly replaced by twelve small planes. The

color is a translucent *green*—in most other recorded cases it is yellow or brown.

One of the most curious specimens is a natural amalgam of silver. It is a dodecahedral crystal, one-half an inch by three-eighths in size, which communicates, by a solid rod of the same material passing through the interior of the rock and nearly concealed from view, with a similar crystal of amalgam. When placed in such a position that one crystal is vertically above its mate, and allowed to stand for a short time, the mercury finds its way downward and distends the lower crystal until its faces are quite obliterated. In fact, it is converted into a pear-shaped drop, and looks as if it were about to fall from the crystal. When the specimen is inverted and allowed to remain so for half an hour, the mercury percolates through the solid mass of amalgam, the distended crystal acquiring its former definite outlines, and settles into a drop depending from the apex of crystal No. 1. This *lusus naturæ*, an hour-glass of metallic crystals, is, I believe, without parallel.

Then there is a resplendent crystal of axinite from Switzerland, among multitudes of others, which is three inches upon one of the faces and four inches measured along its greatest dimension; and a cluster of stibnite crystals from Hungary, weighing perhaps five pounds, of which the largest crystal is a prism three inches long and three-eighths of an inch thick, perfectly terminated.

In conclusion, the emeralds deserve our admiration, as they would that of persons least sensible of natural beauty. Of these, there is a number of large crystals, some mounted upon the rock in which they occur, others detached. Some of the latter from Bogotá have highly-modified terminations. Although not so large as the others, being but one-half an inch in length and three-eighths of an inch in thickness, by far the finest emerald is one which is implanted, along with smaller crystals, upon a piece of rock from the Ural Mountains. It has a perfect termination, presenting very many rhombohedral and pyramidal planes. Without a flaw, absolutely limpid, and of wonderful purity and depth of color, it is a natural gem, in the eyes of a mineralogist incomparably more beautiful than any cut and polished jewel could be. Its history might suggest to the writer of fictions some features of a romance, it having been given by a Czar of Russia to Taglioni, and subsequently placed by her in pawn with a wealthy gentleman in Paris.

## A FREAK OF NATURE.

THERE were recently exhibited in Berlin and Paris two individuals who attracted much attention among scientific men, owing to a very singular development of hair upon the face and neck. In Paris they received the appellation of *hommes-chiens* (dog-men), from the resemblance of the adult's face to that of a Skye terrier. The portrait here given of Andrian Jeftichjew hardly does justice to this striking resemblance, though in other respects it is a faithful representation of the man's curiously hirsute countenance. Andrian is about fifty-five years of age, and is said to be the son of a Russian soldier. In order to escape the derision and the unkind usage of his fellow-villagers, Andrian in early life fled to the woods, where, for some time, he lived

FIG. 1.



ANDRIAN JEFTICHJEW.

in a cave. During this period of seclusion he was much given to drunkenness, and even yet he is said to live chiefly on *sauer-kraut* and *schnapps*. His mental condition, however, observes a medical journal, does not seem to have suffered, and he is, on the whole, of a kindly and affectionate disposition to his son and those about him. It may be of interest to state that Andrian is an orthodox member of the Russo-Greek Church, and that, degraded as he is intellectually, he has very definite notions about heaven and the hereafter. He hopes to



introduce his frightful countenance into the court of heaven, and his present tour may be regarded as a sort of preparation for death, as he devotes all the money he makes, over and above his outlay for creature comforts, to purchasing the prayers of a devout community of monks in his native village, Kostroma, after his mortal career is ended.

Andrian is of medium stature, but very strongly built. His excessive capillary development is not true hair, being simply an abnormal growth of the *down* or fine hairs which usually cover nearly the entire surface of the human body. Strictly speaking, he has neither head-hair, beard, mustache, eyebrows, nor eyelashes, their place being taken by this singular growth of long, silky down. In color this is of a dirty yellow; it is about three inches in length, all over the face, and feels like the hair of a Newfoundland dog. The very eyelids are covered with this long hair, while flowing locks come out of his nostrils and ears. On his body are isolated patches, strewed, but not thickly, with hairs one and a half to two inches long. Dr. Bertillon, of Paris, compared a hair from Andrian's chin with a very fine hair from a man's beard, and found that the latter was three times as thick as the former; and a hair from Andrian's head is only one-half as thick as an average human hair.

FIG. 2.



FEDOR JEFTICHJEW.

When these strange beings were exhibited in Berlin, Prof. Virchow was much interested in them, and gathered all accessible information about their life and ancestry. He states that Andrian is, so far as known, the first of his line to present this wonderful hirsuteness. Neither his reputed father nor his mother presented any peculiarity of

this kind, and a brother and sister of his who are still living are in no wise remarkable for capillary development. Andrian married and had two children, who died young; one of these was a girl, who resembled her father; but of the other, a boy, nothing can be ascertained.

Fedor, whose portrait we give, is Andrian's illegitimate son, and is about three years of age. He is a sprightly child, and apparently more intelligent than his father. The growth of the down on his face is not yet so heavy as to conceal his features, but there is no doubt that when the child comes to full maturity he will be at least as hirsute as his parent. The hairs are as white and as soft as the fur of the Angora cat, and are longest at the outer angles of the eyes; there is a thick tuft between the eyes, and the nose is well covered. The mustache joins the whisker on each side, after the English fashion, and this circumstance gives to accurate portraits of the child a ludicrous resemblance to a well-fed Englishman of about fifty. As in the father's case, the inside of Fedor's nostrils and ears has a thick crop of hair.

It is remarkable that both Andrian and Fedor are almost toothless, the former possessing only five teeth, one in the upper jaw and four in the lower, while the child has but four teeth, all in the lower jaw. These four teeth are, in both cases, the incisors. To the right of Andrian's one upper tooth there still remains the mark of another which has disappeared. That beyond these six teeth the man never had any others is evident to any one who feels the gums with the finger.

Buffon, in the supplement to his "Natural History" (1774) mentions a native of Russia, whom he had seen, and whose entire face was covered with hair. But a more exact counterpart of Andrian is found in a Burmese family living at Ava, and first described by Crawford, an English traveler, in 1829. At the time of Crawford's visit to Ava, Shwe-Maong, the head of this family, was about thirty years of age. His whole body, except the hands and feet, were covered with silky hairs, which, on the shoulders and along the spine, attained the length of five inches. Shwe-Maong arrived at puberty at the age of twenty years, and it was only then that he lost his milk-teeth, which were replaced by five teeth in the upper jaw, one canine and four incisors, and four incisors in the lower jaw. He had four daughters, one only of whom resembled her father. She was found living at Ava by a British officer in 1855, who states that her son was hairy like his grandfather, Shwe-Maong.

In "Animals and Plants under Domestication," Darwin mentions Julia Pastrana, a Spanish dancer, or opera-singer; she was "a remarkably fine woman, but she had a thick, masculine beard, and a hairy forehead; she was photographed, and her stuffed skin was exhibited for a show. . . . From the redundancy of her teeth, her mouth projected, and her face had a gorilla-like appearance." A writer in the French journal *l'Illustration* gives us a fuller account of this woman.

“She was of very dark complexion,” says he, “short of stature and well proportioned; her hands and feet were small, her nails yellow; she had a beautiful breast. Her tresses were very long, deep black, and coarse as horse-hair, and she had a strong beard. Her forehead was overgrown with hair, down to the bushy eyebrows, which overshadowed her soft, humid eyes within their border of black lashes.

FIG. 3.



JULIA PASTRANA.

Her face was made specially hideous by the excessive development of the half-open lips; she spoke with difficulty, and sang mezzo-soprano in Spanish. The parts having the heaviest covering of hair were the shoulders and the hips, the breast and the spinal column. On the limbs the hairiness was greatest on the inner side.”

Mr. Darwin recognizes the existence of a constant relation between the hair and the teeth, and cites the deficiency of teeth in hairless dogs. He says that in those exceptional cases in which the hair has been renewed in old age, this has “usually been accompanied by a renewal of the teeth.” According to him, the great reduction in the size of the tusks in domestic boars probably stands in close relation with their diminished bristles. Then, after referring to the Burmese family and Julia Pastrana, Mr. Darwin says: “These cases forcibly call to mind the fact that the two orders of mammals—namely, the Edentata and Cetacea—which are the most abnormal in their dermal covering, are likewise the most abnormal by deficiency or redundancy of teeth.”

## CORUNDUM.

WITHIN the past two years, the attention of the scientific world, especially, has been directed to the above mineral, from the fact of its discovery, in place, in this country. A number of communications on the subject have been published by prominent men, the most important of which are those from Profs. Genth and Lesley, of the University of Pennsylvania; Prof. Charles U. Shepard, of Amherst College; Dr. A. C. Hamlin, of Bangor; and Dr. J. Lawrence Smith, of Kentucky. These papers are mostly of value to men of scientific pursuits. Our readers will be interested in more detailed information as to this mineral, and the locality where first in the history of the world it is legitimately mined.

Although corundum has been in use, as an abrasive, from an early age, and under various names, it was not until near the commencement of the present century that its localities were found and examined by scholars, and its true place in mineralogy determined. For thousands of years the Chinese had used it, under the name of adamantine spar; the Persians, as Armenian whetsone; the Hindoos, as corundum; and the Egyptians, as the iron-stone of the Red Sea. The natives of these countries had gathered it from the beds of mountain-torrents, or in the alluvium of the valleys, after the annual rains had washed it down, freeing it, in the transit, from its associate minerals and impurities; but no attempt at its legitimate mining had ever been made until within the past two years, in the United States, in the State of North Carolina. The mineral, from whatever locality it comes, is now known in science and commerce as corundum—the name given it by the Hindoos, and meaning cinnamon-stone, from the resemblance in color to that article, of the variety found in their country. It is pure crystallized clay or alumina, and is the next hardest substance in Nature to the diamond, reducing to powder all substances save that gem.

Until the researches of Haüy, the distinguished French *savant*, about the commencement of this century, the three forms of alumina, known as sapphire, corundum, and emery, were supposed to be distinct species. His analysis made them three varieties of one species; a decision confirmed by chemists since, and now universally accepted. The earliest extended reference to corundum, of any value to science or trade, appears in a joint paper by Count Bournon, of Paris, and Sir Charles Greville, of London, prepared for the Royal Historical Society of London, in 1798; which was soon followed by a more careful mineralogical treatise, by the first-named scientist, prepared by him for the same society. Sir Charles Greville's observations were

based on data collected by him at a point in the alluvium in India where the natives had for ages gathered the mineral. Those by Count Bournon were the results of his studies of the mineral at Paris, from specimens brought him from several points, especially in India and Ceylon. At a later date, we have interesting information from Sir Alexander Burnes as to the celebrated ruby locality of ancient Bactria; and from Sir James Tennent and Sir Samuel Baker, as to the famed sapphire districts of Ceylon, which were carefully examined by them during a protracted residence there. A most interesting account of these localities was also published in the *Ceylon Observer* for June, 1855, by Mr. William Stewart, of Colombo. In the *American Journal of Science* for the years 1850, 1851, and 1866, are three papers on granular corundum, or emery, by Dr. J. Lawrence Smith, of Kentucky; the first two descriptive of the emeries of Asia Minor, and localities on the islands of the Ægean Sea; the third, on the mine in Western Massachusetts, known as the Chester mine. These papers are of the first importance in all questions concerning the commercial emeries of our own or foreign countries, and cover the ground of investigation to the date of the North Carolina discovery, and the communications thereon, enumerated in the opening paragraph of this article.

Up to the date of 1871, corundum, or its gems, had never been found *in situ*. Both were looked for in mountain-torrents, or beds of gravel at their base. Emery had for many years been mined in the islands of the Ægean Sea, but had not been scientifically studied in position, until the researches of Dr. Smith, alluded to; since which date, however, it has been found in place at various points in our own and other lands. About the year 1800 it became known that corundum existed, in small quantities, all along the mountain-line of sea-coast, from Maine to Georgia; and, twenty-five years since, it was found in bowlders, in considerable quantities, in Southeastern Pennsylvania. Near the same time a large fragment of massive sapphire was picked up in Western North Carolina, and elicited much attention from mineralogists; but, careful further search in the locality for it being fruitless, there has been since but little effort to find it at any point in the Appalachian range. Whatever effort was made, however, settled the point that corundum existed, in considerable quantity and different degrees of purity, at twenty-five or more localities scattered from New York to Northern Alabama.

In the spring of 1871 Colonel C. W. Jenks, of St. Louis, being in want of an abrasive more powerful than Naxos emery, started out into the mountains of Tennessee and North Carolina in search of corundum, in sufficient quantity to mine profitably. From many localities where the mineral showed itself, he selected one near the head-waters of the Tennessee, in Southwestern North Carolina, nine miles east from Franklin, the county-seat of Macon, and commenced his work. A

large price was paid for mountain-land, at a site where the mineral had been found on the surface in considerable quantities. A canal was cut from a mountain near, that furnished hydraulic power; a gang of a dozen mountaineers were engaged as miners, and ground was first broken in the search for corundum in position. There being no precedent or guide in mining for corundum, experience was the teacher, and a dear one, for nearly a year of energetic and toilsome exploration. The question to be solved was, whether the mineral in any quantity lay beneath the surface, upon which, all former supplies had been gathered; and, if so, whether it would show itself in bowlders, segregated masses, pockets, or true veins. The country rock is granite and gneiss; the spur or ridge, where the mineral showed itself, a trap of chromiferous serpentine, or chrysolite formation. The strata developed is chrysolite rock, mixed with anthophyllite—a layer of micaceous rock—a seam of chalcedony—a stratum of chlorite, of the variety ripidolite, and a gangue of the same, which proves to be the usual matrix of the corundum. Eight months of hard labor settled the question that corundum was there in immense quantity, and that it would be found in veins varying, as is usual in other minerals, from a few inches to several feet in width. These should be termed, what they are, embedded veins, between hanging and foot walls of chrysolite, the gangue being of various minerals—generally, however, of ripidolite, as stated; but sometimes that mineral running into mica schist, talc, spinel, jefferesite, and feldspar. In one of these veins, in a pocket of jefferesite—a golden-yellow mica—there was found much the largest and finest crystal of corundum known, of a fine sapphire and ruby color, weighing 312 pounds, and now the property of Prof. Shepard, of Amherst College. This unique specimen would undoubtedly command one thousand dollars, were it for sale, various collectors of Europe being anxious for its possession. Corundum from this mine proves to be of excellent quality. Taking sapphire as the standard at 100, the product of the mine has a power of from 90 to 97 as an abrasive, while that of the best emery, the Naxos, numbers from 40 to 57. The veins, five of which have been opened, run northeast and southwest, dip under at an angle of  $45^{\circ}$ , and are, at the deepest point reached, seven to ten feet wide. There is also remarkable association of other interesting minerals of tourmaline, spinel, zerkon, etc., while the corundum itself shows almost every shade of color from white to black. It is also remarkable that the mine contains all the varieties in color, texture, and crystallization, found in the aggregate corundum localities of the globe. Association of two colors in the same crystal is spoken of by the best writers as a somewhat rare matter, even in Ceylon. One crystal was shown us from this mine, weighing two pounds, with blue, ruby, pink, yellow, and green colors of great brilliancy and transparency; and a small hand-collection, which contained a variety in form, perfection, and purity of color, not equaled



by any collection of corundum in the known cabinets of Europe—for from no other locality have such specimens been found, excepting in the perfect gems from Ceylon and Burmah.

We now come to the most interesting feature of the mine. It was natural that, with so much of purity in the amorphous mineral, and perfection and beauty in the crystals found with it, Colonel Jenks should conclude that there might be gems in the mine. But from no quarter but his own observations did he get any encouragement in this direction. The best English authority on gems and their localities, Prof. King, of Trinity College, Cambridge, says: "The corundum gems have never been found in place, but always in the alluvial or sands of the rivers." After eight years of residence in Ceylon, the source from which the best sapphires of the world have come from an early period, and much acquaintance with the best gem-localities of the island, Sir Samuel Baker remarks: "The sapphires were created in the peculiar secondary formation, where they are always found, which is composed of water-worn pebbles, in a conglomerate of blue and white clay, buried ten to twenty feet beneath the surface of the valleys," etc. This was the opinion of Buffon, and other eminent scholars. The ruby localities of Bactria, visited by Sir Alexander Burnes, are said by him to be of similar character. Sir James Tennent, in his elaborate work upon Ceylon, expresses similar views, yet ventures the opinion, from a survey of the whole subject, that gems might be found in place in the island. He says, in confirmation of this view, that he saw in one of the mountain-ranges "a stratum of gray granite, with iron pyrites and molybdena, which contained great quantities of very small rubies." Whether he ascertained the nature of the gems he calls rubies by analysis, or only from casual observation, he does not say; but garnets of great beauty so often occur in such a matrix that it would not be safe to rely on those stones he saw—unless analyzed—as the ruby corundum. Seeking information from a later, and perhaps we are justified in saying, on this matter, the most eminent authority, that of Dr. J. Lawrence Smith, of Kentucky, he says, in substance: "The gems of corundum cannot be expected to appear where the amorphous masses of the mineral abound, and, *vice versa*, that corundum, for commerce, will not be found with the precious gems," etc., his conclusion being based upon "the diverse composition of the two forms of the mineral, shown by analysis, and which would require for their formation different geological and mineralogical conditions," etc.

Not dismayed by this array of scientific opinion and experience, however, Colonel Jenks made careful examination of the material as it came from the miners' hands, and the results led him to give them special instructions as to the nature of their operations. As the geodes in the formation of silica have been found to contain the finest quartz crystals, he hoped to find in the mine something of the same character, of alumina. He was rewarded by one or more large pockets of geodes

of dark-green chlorite, from the size of a walnut to that of a fifty-pound shot, within which were one or more crystals of corundum, sometimes blue and white, and, in few instances, of ruby color. None of them were entirely transparent; none of the geodes had cavities, as is the case in those of quartz formation; yet the prospect in this direction is most promising. The result thus far, however, is most encouraging in the rock-strata itself, which is the proper gangue of the corundum. With the hundred tons the mine has yielded for abrasive purposes, the workmen have taken from the place of their birth—a solid, undisturbed matrix of ripidolite—beautiful specimens of the nine corundum gems known by lapidaries by the prefix “Oriental,” because of their superior hardness and brilliancy; and also because those of this character, in lustre and composition, were first brought from the East. These are known by name as Oriental sapphire, ruby, emerald, topaz, asteria, amethyst, chatoyant, girasol, and white or colorless sapphire, this last often used in place of the diamond. The general characteristics of these stones, such as color, lustre, hardness, etc., are, by the first lapidaries of this country and Europe, pronounced as not inferior to those of the best localities of the Old World. One of them was sold to a lapidary of Amsterdam, Holland, for \$4,000. Others of much beauty have been cut, and are owned in this country and Europe. In this connection it is of value to note that Count Bournon, during his investigations, made a list and analysis of the associate minerals found, *in transitu*, with the sapphires of Ceylon. Colonel Jenks has had a similar list and examination made of those found *in situ* with the gems of his mine. All the minerals found in the Ceylon gem-deposits are found in the North Carolina locality.

There can be no doubt, therefore, that Colonel Jenks has made the discovery, in America, of the most precious gems next to the diamond, where they have been sought for in vain elsewhere, *in a matrix of solid rock-formation*. We look for further interesting developments at this unique and thus far unparalleled alumina deposit.

---

## ATMOSPHERIC ELECTRICITY AND OZONE: THEIR RELATION TO HEALTH AND DISEASE.<sup>1</sup>

By GEORGE M. BEARD, M. D.

**A**MONG the published list of questions at the civil service examination of the Board of Health of New York last summer I observed this: “What is the composition of pure air?”

<sup>1</sup> Read before the American Public Health Association, in New York, November 13, 1873. It was voted by the Society to publish this paper in their “Transactions,” but, through the courtesy of the Secretary, the author is allowed to publish it independently.

As I laid down the paper I asked myself this question, or, rather, I put to myself the same question in another form: "Is there among the sons of men any one who really knows the composition of pure air?"

Still further I queried with myself what answer I should have given to the question had I been one of the applicants for a position on the Board of Health, and it seemed to me that, after stating what almost every school-girl knows about the relative proportions of oxygen and nitrogen, I should have added this codicil: "The question of the composition of pure air is one that is too complicated to admit of an answer." What I have to say this morning on atmospheric electricity and ozone will serve, so far as it goes, to enforce this view.

*How the Subject of Atmospheric Electricity and Ozone has been investigated.*—During the past quarter of a century regular daily observations of atmospheric electricity have been made in Brussels, Munich, and for the past ten or fifteen years in St. Louis. The difficulties in the study of the subject are very great, but, from the accumulated observations of the different investigators, some few interesting and important general facts have been secured.

*Apparatus for studying Atmospheric Electricity; Measuring Apparatus.*—Prof. Dellman, of Kreuznach on the Rhine, for several years made three regular observations each day of the atmospheric electricity. The electrometer that he used in these observations is a torsion balance. A small thread of glass going vertically through a glass tube has on its lower extremity a small needle of brass fastened to it. This light brass needle, when influenced by any force, can move over a metallic disk with a graduated scale. Below this light brass needle is another light brass needle, which is fixed and isolated from the metallic disk, and connected with a metallic wire which receives the electrical charge from outside. By means of a micrometer screw the upper needle can be lowered and raised so as to touch the lower needle, or be kept above it.

The whole instrument rests on three iron legs, which can be screwed up and down so as to give it the level required. When the wire outside receives a charge of electricity, it communicates this charge to the lower needle. If, now, the upper needle be lowered and brought in contact with the lower one, it also receives a charge of electricity. But, as like electricities repel each other, the other needle will be at once driven off over the graduated scale. The number of degrees that it is driven will depend on the strength of the charge. To determine whether the electricity is positive or negative, subsequently charge the wire with electricity of known quality. If they are alike—that is, if the first charge be of the same quality as the second—the needle will be repelled still farther; if unlike, the needle will return toward the fixed needle.

*Collecting Apparatus.*—Dellman's apparatus for collecting atmospheric electricity is a hollow brass or copper ball about six inches in diameter, with a stem of metal. The metallic stem rests in a metallic tube, but is isolated from the tube by shellac. This apparatus is attached to a pole almost thirty feet long. This pole is drawn by a windlass up the walls of a house to the top of the roof. The operator then touches the stem of the ball with a piece of brass in the shape of a half-moon. This charges the ball with electricity. The pole is now let down at once, and the collecting apparatus is brought in control with the measuring apparatus. The electricity which is thus collected in the ball is developed in it by induction. The natural electricity of the ball is separated by the surrounding atmospheric electricity into positive and negative electricity. One of these goes to the lower part of the ball, the other remains in the upper part. Atmospheric electricity is usually positive. The natural electricity of the ball being decomposed, the negative is attracted to the upper and the positive to the lower part. When the operator touches the stem of the ball with the piece of brass, the positive electricity is conducted through his body to the ground, and the negative remains in the ball.

*When, therefore, the electrometer shows negative electricity, it indicates positive electricity in the atmosphere, and vice versa.*

It has been shown that there are two daily tides of positive atmospheric electricity—the high tides between 9 and 12 A. M. and between 6 and 9 P. M.; the low tides between 2 and 5 P. M. and 1 and 5 A. M. The annual variations are fully as marked as the diurnal; the quantity of positive atmospheric electricity being greatest in the winter, least in the summer. Dr. Wislizenus found that, in 2,124 observations made at regular hours, the atmospheric electricity was 2,046 times positive and but 78 times negative. Of the 78 times, 30 were connected with thunder or hail storms, or by thunder and lightning, 23 by common rains, and 20 by high winds and gales without rain, thunder, or lightning, 4 by snow, and 1 by fog.<sup>1</sup>

According to Herschel, out of 10,500 observations at the Royal Observatory, only 364 showed negative electricity. The remainder, 10,176, all showed positive electricity. Negative electricity was usually attended with rain.

It seems, therefore, that the chief cause of a condition of negative atmospheric electricity is storm, and especially thunder-storms, and that at all other times positive atmospheric electricity prevails. In very many cases this change to negative electricity takes place shortly before the storm approaches; during its progress there may be—especially in thunder-storms—rapidly-repeated alternations of positive and negative conditions, followed by an equilibrium, or by positive electricity.

Dr. Wislizenus, of St. Louis, also found that snow-storms and fog

<sup>1</sup> Dr. A. Wislizenus, in Transactions of St. Louis Academy of Medicine.

were usually accompanied by an increase of positive electricity; this observation is of interest, because it accords with the fact that the approach of snow-storms and the presence of simple fog do not cause the exacerbations of rheumatic and neuralgic pains that are experienced on the approach of storms of rain, or thunder and lightning.

*Ozone-History.*—From the earliest recorded ages a peculiar odor has been observed during thunder-storms and other electrical disturbances, and especially in connection with flashes of lightning. The peculiar odor of thunder-bolts has been referred to by Homer, both in the “Iliad” and the “Odyssey.” Jupiter is said to strike a ship with a thunder-bolt, “ἐν δὲ θείου πλῆτο,” full of sulphurous odor, and to hurl a bolt into the ground “with the flame of burning sulphur.” This peculiar sulphurous odor has been observed not only during thunder-storms, but also, it is said, during displays of northern and southern auroræ.

So long ago as 1785, Van Marum, of Holland, observed that electric sparks passed through oxygen gas (that had been discovered by Priestley only eleven years before) gave rise to a peculiar sulphurous or electrical odor; and, at the beginning of the present century, Cavallo, a prominent name in the history of electricity, called attention to the fact that this “electrified air,” as it was termed, had an antiseptic effect on decomposing matter, and was a salutary application for fetid ulcers. In 1826 Dr. John Davy, in a measure anticipating Schönbein, recognized this peculiarity of the atmosphere, and devised tests for detecting it.

The real scientific history of ozone dates from 1839, when Prof. Schönbein, of Basle, the renowned inventor of gun-cotton, observed that the electrolytic decomposition of water was attended by a peculiar odor resembling that evolved during the working of a frictional electric machine. In 1840 Schönbein called the attention of the scientific world to the newly-discovered substance, to which he gave the name of *ozone*, from the Greek ὄζω, to emit an odor. He showed that this odor appeared at the positive pole during the electrolysis of water. He furthermore pointed out that ozone may be produced by the slow oxidation of phosphorus in moist air or oxygen, and that the odor was similar to that which is observed during flashes of lightning. Schönbein studied hard on the subject for many years, and arrived at the conclusion that oxygen is capable of division into a negatively polar state, ozone, and a positively polar state, which he called *antozone*. During the past quarter of a century the subject of ozone has been studied by some of the most eminent scientists of the age, among whom we may mention the names of Berzelius, De la Rive, Marignac, Becquerel, Faraday, Fremy, Meissner, Houzeau, Scouteten, Odling, Andrews, Tait, Fox, Fischer, Boeckel, Zeuger, Moffat, Nasse, Engler, Erdmann, Angus Smith, Poey, A. Mitchell, Soret, Baumert, Williamson, and very many others.

*The Nature of Ozone and Antozone.*—The result of this quarter of a century of research is the present conclusion that ozone is *condensed allotropic oxygen*.<sup>1</sup> In regard to antozone there is much difference of opinion among scientists. There are those who declare that it is a myth. The original hypothesis has recently been losing its hold on the scientific mind, and further researches are necessary to determine what it is and what it is not. The present opinion of the German philosophers is, that antozone is the *peroxide of hydrogen diffused through the air*.

*Preparation of Ozone.*—Ozone is prepared in various ways—by passing electric sparks, or electricity without sparks, through oxygen or air, by the electrolysis of acidulated water, by oxidizing phosphorus in moist air, by the action of strong sulphuric acid (three parts) on permanganate of potash (two parts), by sending water in the form of spray through air, by introducing hot glass rods into vessels filled with the vapor of ether, and by the slow oxidation of ethers and oils, etc., when exposed to light.

*Properties of Ozone.*—Ozone is a colorless gas, with a powerful and peculiar odor. Like oxygen, it is an oxidizing agent of great power. It changes indigo into *isatin*, the black sulphate of lead into the white sulphate of lead. It oxidizes antimony, manganese, arsenic, iron, zinc, tin, silver, lead, bismuth, and mercury. Many of the lower oxides it transforms into peroxides. It corrodes India-rubber and decolorizes blue litmus-paper. It acts with great rapidity on iodide of potassium, liberating the iodine. It quickly consumes ammonia, changing it into nitrate. It decomposes *hydrochloric acid*, liberating the chlorine. It is insoluble in acids, alkalies, alcohol, ether, the essential oils, and water. The odor of ozone is very penetrating; air containing but one millionth of it is said to be perceptible to the olfactories. The peculiar odor of sea-air is in part the result of ozone. All air, even the purest, has more or less ozone; but so accustomed do we become to it that it is only by sudden change into it that we perceive it. Visitors at the Mammoth Cave, Kentucky, report that, on emerging, the air has a peculiar and vivid odor such as they never before realized. That we can in a half-hour become so used to the foul air of a closed room that we do not perceive its odor until we leave it for a few moments and then return to it, is the experience of every one. The peculiar odor of ozone can be obtained very easily indeed by touching a metallic electrode of a galvanic battery of a number of cells against one of the plates of the batteries so as to make a connection of the current, or by touching the metallic ends of the poles for a moment with the spark thus produced.

*Ozone in the Atmosphere.*—Ozone, like electricity, exists normally in the atmosphere, but varies in amount in different localities at differ-

<sup>1</sup> "Ozone and Antozone: their History and Nature." By Cornelius B. Fox, M. D. London, 1873.



ent seasons and in different hours of the day, and is considerably dependent on various meteorological conditions.

*It varies with the Locality.*—It is more abundant in the country than in the city; by the sea-side than inland; among mountains than in valleys; in well-drained neighborhoods than in those where such sanitary provisions are disregarded. The opposite results of different observations in different localities are accounted for in part by the fact that the amount of ozone is not everywhere constant. Ozone is not often found in closed rooms or chambers. Those who stay in-doors are deprived both of atmospheric electricity and ozone. Like electricity, it increases with the altitude; hence we may in part explain the beneficial effects of mountain-air. The air of the sea is richer in ozone than the air of the land, because evaporation is attended with the simultaneous development of oxygen and ozone. Hence it is that tests applied over the surface of the sea or of lakes, ponds or rivers, show a deeper tint than tests applied over the land. An excess of sea-air will blight vegetation in the vicinity of the ocean; delicate fruits, as the peach and the plum, are cultivated only with difficulty. It has been observed that a prolonged storm coming from the sea will blight vegetation. Possibly the excess of ozone may be a factor in this destruction.

*It varies with the Season.*—Ozone, like electricity, is more abundant in the winter than in the summer. Atmospheric ozone is not measured with the same accuracy as atmospheric electricity, and therefore the regular gradations during the spring and autumn have not been established as in the case of the latter agent. For the same reason there is much discrepancy among different observers. It is believed that the relatively small amount of ozone in the summer and early fall is due partly to the fact that it is consumed in oxidizing the impurities of the air, and partly to the fact that there is less atmospheric electricity at that time.

*It varies with the Hour of the Day.*—There is considerable difference in the conclusion of different observations, but the average results seem to show rather more ozone in the atmosphere during the night than during the day. Like atmospheric electricity, ozone rises and falls in pretty regular tides twice during the twenty-four hours. The maximum periods are between 4 and 9 A. M. and 7 to 9 P. M. The minimum periods are between 10 A. M. and 1 P. M. and between 10 P. M. and midnight. It will be seen that ozone is at its minimum when the sun is at the zenith, and its maximum about sunrise and sunset. It varies with atmospheric conditions, as electricity, rain, fog, thunder-storms, snow, wind, clouds, halos, and auroras, eclipses, etc. There is a certain correspondence between the tides of electricity and of ozone; they seem to rise and fall together. This will be apparent on comparing the statements made above. A comparison between atmospheric ozone and electricity has been made by Quetelet, who has given the subject special attention. His obser-

vations, which were made with Peltier's electrometer in August, 1842, are represented in the following table :

Hours.	Electricity.	Ozone.
6 A. M.	+17	4.10
7 "	27	4.60
8 "	36	4.88
9 "	27	4.45
10 "	20	.31
11 "	14	.41
12 M.	12	.80
1 P. M.	10	.96
2 "	5	1.17
3 "	3	1.31
4 "	5	1.40
5 "	11	1.33
6 "	18	1.33
7 "	24	1.41
8 "	30	1.56
9 "	32	1.70
10 "	30	1.00
11 "	19	1.15

Ozone, like electricity, seems to depend in a measure on the humidity of the air. The relation of fog to atmospheric ozone is not yet determined, but it seems to be agreed that during snow-storms it is increased. Thus, Wolf gives the following comparison :

Amount of atmospheric ozone in fine days, 4.186.

Amount of atmospheric ozone in rainy days, 11.40.

Amount of atmospheric ozone in snowy days, 14.15.

It will be remarked that snow-storms also favor atmospheric electricity. The direction of the wind has a certain influence, as is well recognized, on ozone. According to Lowe, ozone is most abundant during a southwest or south-southwest wind, and least abundant when the wind is north or northeast. There is a maximum when the barometer is low, and a minimum when it is high. Other inland observers agree with Mr. Lowe. At the sea-side, winds blowing from the sea bring with them abundant ozone.

When the sky is darkened with clouds, there is more ozone than when it is clear. Before thunder-storms, or while they are at a distance, ozone, like electricity, increases, and various changes and fluctuations may occur during the progress of the storm.

Summing up in a few words, we may say that atmospheric ozone is more abundant during the winter and spring, because in those seasons there is much rain, snow, hail, and wind, a low temperature, and a maximum of electricity. During these seasons, also, there is little decomposition going on in the vegetable world. In the summer and autumn, atmospheric ozone is least abundant, because, during these seasons, there is no snow, or hail, less wind, rain, high temperature, a minimum of electricity, and a great amount of decomposition of animal and vegetable matter, by which the air becomes polluted, and is neutralizing and purifying while the ozone is consumed.

*Average Quantity of Ozone in the Atmosphere.*—The quantity of ozone in the atmosphere is exceedingly minute. The proportion varies with the locality, the season, the hour, etc., as we have already seen, and it also varies with the altitude, for it is with this agent as with electricity—it increases as we rise above the earth. According to Houzeau, air of the country, about six feet above the earth, contains about  $\frac{1}{450000}$  of its weight of ozone, or  $\frac{1}{700000}$  of its volume. The quantity is so minute that it may probably be increased several fold without perceptible injury to man or animals.

*Origin of Atmospheric Electricity and Ozone.*—The sources of ozone in the atmosphere are almost innumerable. Like atmospheric electricity, it results from a wide variety of countless and ever-changing influences; it is one of the grand resultants of the ceaseless chemistry of the earth and sky. The evidence is now pretty clear that one prominent source of atmospheric ozone is in vegetable life. The oxygen that plants evolve from their leaves is more or less ozonized. It is claimed that ozone is developed with the perfume of flowers. The most odorous flowers, as the heliotrope, hyacinth, and mignonette, are the most prolific generators of ozone. This ozonic property of flowers is most manifest under the direct influence of sunlight. Lavender, fennel, mint, clove, and cherry-laurel, evolve ozone with special abundance when exposed to the solar rays. It is believed that the oxidation of essential oils, as anise-seed, bergamot, etc., under exposure to the light and air, develops ozone, and that in all flowers the source of the ozone is the essence; hence it is that the most odorous are the most ozoniferous.

If we accept these conclusions, we must also concede that the custom, now almost forgotten, among physicians, of providing the handles of their canes with vinaigrettes, with the fancy that the fumes would protect them against infectious disease, has a certain scientific basis. The aroma of snuff is said to develop ozone, and for years snuff has been regarded as a disinfectant.

Electricity, as is well understood, is generated by any kind of chemical change or action. Even friction and pressure cause electricity to be evolved, as was shown by Armstrong's experiments with jets of condensed air, liberated under high pressure. It was shown by Faraday that the friction of water dropping against bodies gives rise to electricity, and it is probable that the same effect follows the friction of water against air.

Volta showed, nearly a century ago, that the spray of a fountain furnishes negative electricity. Trolles, and afterward Humboldt, observed that a cascade or water-fall filled the air for some distance with negative electricity, and Bell thinks he has proved that a cascade is negative at the top, and positive at the bottom; that the positive electricity passes into the earth, leaving the negative in the spray.

We are then to look for the sources of ozone, as of electricity, in all

the infinite play of the terrestrial powers: in the falling away of the rocks, and the springing forth of plants; in the oxidation of metals, and the emission of the perfume of flowers; in the deposition of dew, in the falling rain, the rattling hail, and the drifting snow; in the rushing of the wind, and the conflict of the storm; in the friction of the clouds as they pass in the sky, or rest on the summits of the mountains; in the ceaseless evaporation on sea and on land; in the rushing torrents of the hills and the dashing breakers on the shore.<sup>1</sup>

*Ozone a Disinfectant.*—The disinfecting powers of ozone have long been noted. It is one of Nature's great purifiers. It is sometimes generated artificially in hospitals and public buildings. It acts both on animal and vegetable matter. According to Schönbein, air containing but  $\frac{1}{3240000}$  of ozone is capable of disinfecting its own volume of air filled with the effluvia, evolved in one minute, from four ounces of highly-putrid flesh.

Ozone, in disinfecting and purifying decaying and putrid matter, is itself destroyed. It dies, that others may live. Hence it is that there is so little of ozone in the air of towns and cities and villages, and in hospitals. The ozone is consumed in the process of oxidizing the products of combustion and decay.

Dr. Richardson has noticed that oxygen, that has been repeatedly passed over decomposing animal matter, loses its power of oxidation.

*Physiological Effects of Ozone.*—The physiological effects of ozone have been studied both on man and on animals. It is believed that the bracing and inspiring effect of a clear, crisp, and sparkling morning, is due in part to the great amount of ozone in the atmosphere. When it is held in combination with oxygen or common air, it acts much like oxygen, but more powerfully. It affects the pulse, the respiration, and the circulation, in various ways, according to the quantity taken, and the temperament of the individual. In this respect, it behaves like electricity. It has been thought that ozone is formed in the body from the contact of oxygen gas with the blood, and there are those who believe that it is absorbed with the ozone in the air, and is carried into the blood, where it takes part in the process of oxidation.

There is a possibility, if not indeed a probability, that electricity, in its passage through the body, generates ozone in very minute quantities, through the electrolytic and other changes that it produces, and the theory, that the beneficial effects of electrization are in part due to the ozone thus generated, has some plausibility. But on all these subjects very little is known. Experiments made in the laboratory with ozone, artificially prepared, are highly suggestive. Catarrhal symptoms and attacks, much resembling epidemic influenza, are produced by long breathing air laden with ozone. It is stated that it would be difficult to distinguish between the symp-

<sup>1</sup> *Vide* Fox, above quoted.

toms of influenza and the symptoms of an over-dose of ozone. Experiments on animals have shown that irritation of the mucous lining of the throat and nostrils, with febrile symptoms and congestion of the lungs, may be quickly excited by breathing air containing a large percentage of ozone. If animals are, for a long time, subjected to ozone, they perish. In their susceptibility to it, however, they vary widely. A rabbit, breathing air mingled with  $\frac{1}{2000}$  of its weight in ozone, has died in two hours. Mice, breathing air about  $\frac{1}{6000}$  of ozone, have died immediately. Rats are more susceptible than Guinea-pigs, and Guinea-pigs are more susceptible than rabbits. Pigeons are quite tolerant of ozone, and frogs are proof against it, provided they have abundance of water. Birds are specially tolerant of this agent, as might naturally be inferred, since, in the higher strata of the air, where they fly, ozone is more abundant than near the earth.

It has been stated that there is a relation between ozone and intermittent and remittent fevers; that rheumatism is prevalent when ozone is deficient; that, when ozone is in excess, diphtheria, quinsy, small-pox, herpes, measles, scarlatina, and other cutaneous affections, prevail; and that, during the visitation of the cattle-plague in England, ozone was below the usual standard.

There is considerable more of evidence to show that visitations of cholera are accompanied with a diminution in the atmospheric ozone.

Experiments have shown that germs, sporules, bacteria, vibriones, and small monads, with other low forms of life, are destroyed by ozone. On the accepted view that epidemic and infectious diseases are caused by spores, bacteria, etc., we can understand how a deficiency of ozone in the air may invite disease.

The only conclusions on this subject of the relation of atmospheric ozone to disease, that at present seem justifiable, are these:

1. A deficiency of ozone in the air probably has a certain relation to epidemic and chronic disease.
2. Deficiency of ozone invites disease, by debilitating the system, and thus making it less capable of contending with morbid influences.

*Tests for Ozone.*—Of the various tests for ozone, those which are most used are starch and *iodide of potassium*. Fox prefers the *iodized litmus* and the simple *iodide of potassium* test. The litmus-paper and the iodide of potassium must both be pure. The Swedish filtering-paper is the best. Blue litmus is purified by boiling, etc., until it is of a vinous red color. The strips of filter-paper are plunged for *one-third* of their length into a solution of neutral iodide of potassium, made by dissolving  $15\frac{1}{2}$  grains in 321 grains of distilled water.

These tests are exposed to the air for twelve or twenty-four hours beneath a plate. If ozone be present in the air, the iodized part becomes blue, and the non-iodized part is unchanged. Sometimes the test-paper is placed in ozone-boxes, so constructed that a current of air passes through them.

The practical bearings of atmospheric electricity and ozone are manifold:

1. Many nervous and other diseases and very many nervous sensations are perceptibly affected by changes in the quantity of electricity and ozone. Making the necessary concession that the subject of the relation of atmosphere to health is one of many complications, still we are now in a position to claim with considerable positiveness that a part of the benefit or injury that is derived from change of climate, or from the various atmospheric changes, is the result of variations in the amount of ozone and electricity. After eliminating the factors of heat and cold, which are the most obvious and best understood of all atmospheric qualities; of moisture and dryness, the potency of which is everywhere recognized; of carbonic and nitric acid; of oxygen pure and simple, there remains much that only ozone and electricity can well account for.

2. Not a few sensitive and impressible organizations experience variations of strength and debility, of vigor and *malaise*, that very well correspond to the variations in atmospheric electricity, or ozone, or both. There are thousands of people who are at their maximum of strength in the cold months of winter, who begin to decline in the spring, who, in the summer, are at their minimum, and who regularly rally during the autumn. There are those who, almost every day, pass through tides of feeling, which, if they do not mathematically correspond to the daily tides of ozone and electricity in the air, do certainly follow so closely as to make us suspect, to say the least, a certain relation between the variable states of the system and the variable states of the air. From 8 to 12 A. M. is the golden time for brain-work, as all students know; from 1 to 4 P. M. there are frequently a dullness and lassitude that make hard toil a task. Many—even those who take but a lunch in the middle of the day—are sleepy at this time, and, unless they are kept awake by business, are disposed to take a nap. The latter part of the afternoon the spirits revive, and between four and eight or nine o'clock is what might be called the silver period of the day for all mental labor. The night is given to sleep, but those who rise very early do not usually labor to so great advantage as those who defer their severest exertions until the forenoon. In these statements we but give the experience of the majority of brain-workers whose temperament is of the susceptible order, and who therefore appreciate the varying moods of the system.

The chief complication that enters into these calculations is the fact that there is least ozone and least electricity in the air when there is most heat, and that heat is of itself debilitating.

3. Irregular disturbances in the electrical condition of the atmosphere, in storms, and especially in thunder-storms, and, in our climate, northeast storms, unquestionably affect the nervous system of impressible temperaments unpleasantly, and bring on or aggravate neuralgic,



rheumatic and other pains, as well as incite mental distress and discouragement.

This fact, concerning which some have been skeptical, is as demonstrable as any general fact of the kind can be, and the opportunities for testing it among the nervous patients in this country are exceptionally abundant. Sensitive patients are oftentimes prophets of the weather; without error they can predict, even twenty-four hours beforehand, an approaching northeast storm, and, before a rising thunder-squall, they are sometimes excessively miserable. There are those who are utterly prostrated before and during a thunder-storm, thrown into vomiting and convulsions; and these spasmodic disruptions are followed by hours or days of exhaustion.<sup>1</sup>

Now, it is just before thunder-storms that the atmospheric electricity is so apt to be negative, and during a thunder-storm the changes in the electrical condition are very rapid.

At the Sussex County Insane Asylum, in England, the chaplain of the institution made for several years a series of experiments which showed very clearly that attacks of epilepsy and mania correspond, in a very large number of instances, to changes in electrical and other conditions of the air, and he believes that electricity is the main factor.

There is nothing strange in all this, for all naturalists know that many plants predict storms with wonderful precision hours before they appear. Man, with his exalted and complex nervous system, and especially civilized man, is far more impressible than any animal or flower.

It is not wise nor scientific nor humane to despise these subtle, storm-anticipating pains from which our patients suffer. If these are not real, nothing is real, and all existence is a delusion and a sham. They are as truly realities as small-pox, or typhoid fever, or a broken leg, and should be considered accordingly. When, therefore, the *Danbury News* man dedicates his almanac to that distinguished collaborator and weather predictor, the inflammatory rheumatism, he is as scientific as he is funny.

4. The beneficial effects of sea and mountain air on invalids may be explained in part, if not largely, by the fact that there is more ozone in the sea-air than in the land-air, and more ozone and more electricity in high than in low altitudes.

In elevated regions the air is, of course, rarer than in low-lying regions, and the quantity of oxygen inhaled must, of necessity, be less

<sup>1</sup> These nervous perturbations, in their various degrees, have seemed to me to be sufficiently frequent and distinctive to entitle them to be regarded as a separate disease. To this disease I have given the name *Astraphobia*. A brief description of this disease, with cases and remarks, can be found in Beard & Rockwell's "Medical and Surgical Electricity," p. 604. Strictly speaking, it comes in the category of affections allied to hysteria, like *agoraphobia* that Westphal has described. *Astraphobia* is more common in women than in men, though I have seen it in both sexes. The tendency to the disease appears to run in families.

than when the air is dense; but ozone and electricity both increase as we rise, and very likely this fact will explain the exhilaration and invigoration which not only consumptives but nervously exhausted patients experience on removing to the mountains. The benefit that consumptives find, by residence in elevated districts, is almost entirely of a general, stimulating tonic character, that could very well be explained by the ozone and electricity which they inhale far more abundantly than in the lowlands. The benefit derived from a change of residence from the city to the country may be, in part, similarly explained.

The influence of atmospheric electricity and ozone must always be taken into consideration in estimating the effects of medical treatment. Exacerbations of neuralgia, or rheumatic pain, or general *malaise*, or attacks of melancholia, or mania, may be excited by low atmospheric conditions, when, perchance, we suppose that the treatment we employ is working badly; and, conversely, the exhilaration that patients feel at various times should sometimes redound to the credit, not of the physician, but of the electricity or ozone in the air. There are days when all our patients seem to be depressed—all appear to be going down—and there are days when all appear to be doing well. We cannot be too cautious in attributing these changes to other factors besides the treatment we employ. We are justified in encouraging disheartened patients, who are ready to perish, with the hope that, not unlikely, they may be suffering from low atmospheric conditions that will in time correct themselves.

In order to settle some of the questions raised in this paper, I would offer these four suggestions:

I. Let daily observations in atmospheric electricity and ozone be undertaken under the patronage of the governments of different countries at all meteorological and astronomical stations. These observations, carried on for a number of years, would help to answer many important queries, and, among others, whether there is more or less of atmospheric ozone in America than in Europe. The data derived from such comparative researches would help, perhaps, to explain the peculiar and unparalleled nervousness of the people of the United States. They might help to explain the extraordinarily stimulating character of the climate of California. They might help to explain the fact that, on the Pacific coast, sunstroke is not apt to occur, even under very high temperature; while, in the East, prostration from exposure to heat not very excessive is, almost every summer, a common affection.

II. Let comparative observations be made of the atmospheric electricity and ozone of low and elevated regions. The data derived from such observations might help to explain the great benefit that consumptives and nervous patients so often find by a residence among the mountains. They might help to explain the absolute relief or cure

of autumnal catarrh or hay-fever that is found in regions lying all the way from five hundred to twenty-five hundred feet elevation above the level of the sea.<sup>1</sup> It has already been shown by the experiments of Becquerel on the plateau of St. Bernard, and by other observers, that there is more of atmospheric electricity as we rise above the earth, and the same has been proved also of ozone. If these results shall be confirmed by a larger induction, by observations among the Catskill and White Mountains, then we should have a potent and suggestive explanation, so far as it would go, of the powerful hygienic effect of mountain residence.

III. In times when certain epidemics are abroad, such as cholera, throat-distemper, scarlatina, etc., let observations made of the atmospheric ozone be compared with observations made at the same season and same place in other years. Of course, whatever the facts may be, we cannot rush to conclusions in this matter. If ozone be absent, may not its absence be due to the fact that it has all been consumed in deodorizing the impurities of the air, which impurities may be the cause of the epidemic?

IV. Let the physiological and therapeutic effects of ozone on the human system be studied by a large and copious induction from a wide variety of temperaments and diseases.

The criticisms that you will make on this paper I can easily foresee. You will say—and not unjustly—that in all these researches, and especially in those that relate to ozone, there is much of vagueness, little of precision—that an enormous margin yet remains wherein we may study or conjecture.

All this I admit freely and fully, but is it not so with the incipience of every science and of all forms of knowledge whatsoever? Shall we wait until our knowledge becomes absolute before we reveal it? Does it not rather become those of us who are seeking truth, as often as may be, to take account of stock of our discoveries? Is it not well, now and then, to take an inventory of our ignorance, and see how little we know? In this grand and long campaign against the kingdom of darkness we must forage on the enemy's country, and sustain ourselves for the toils of the future by the best we can get as we go along. I would be inspired by the words of Confucius: "What we know, to know that we know it; what we do not know, to know that we do not know it, that is knowledge." I would be inspired by the example of Lessing, who preferred to seek after truth, than to find it.

<sup>1</sup> Blakeley, in his work on "Hay Fever," has shown by experiments that more spores and pollen, by far, are found a thousand feet or so above the earth than at the ordinary breathing level. These experiments would indicate that the cure of this disease, by removal to elevated regions, must at least be explained in some other way than by the theory that the mountain air contains less irritating substances. This subject I hope to be able to investigate at the White Mountains during the coming summer.

## THE GREAT CEMETERY IN COLORADO.

BY REV. SAMUEL LOCKWOOD, PH. D.

IN the composition of his ecclesiastical history, an erudite historian chaptered the narrative into centuries. Perhaps for his subject these divisions were sufficiently generous. Still, as measurements of time they were but puny epochs; and yet they were vast enough for the treatment of that ephemeral worker, man. But He, "who worketh hitherto"—who, as the true Earth's Biographer, wrote on the stony rocks—made his divisions THE AGES! Indeed, *can* those epochs be reduced to years? What a scope must the record of his doings have with whom a thousand years are as a day! Accepting these life-cycles with a significance so grand, we reverently look into this great volume. Its opening chapter is the Cambrian age. But—amazing!—the stony laminæ that make up its leaves are scarcely less than *one hundred thousand feet in thickness!* It was a time of dreary wildness, and its primeval life-forms were few, and huge rock-masses were tilted up from that sea, and worn down for the bed of the waters. Next came the Silurian age, singing the weird music of its one world-encircling sea. Its forms of life were innumerable. Then flourished the Brachiopods, or shell-bearing worms, and Mollusca, Crustacea, corals, and a few fishes. Then comes the Devonian age. Now it is that what seemed a monotonous, watery waste becomes as a weary Sahara, with many a green-fringed oasis cheered. The late universal sea is dotted with low-lying islands. Very beautiful, though lowly in rank, and not over-luxuriant in numbers, were the plant-forms that fringed those shores. Then the fishes composed the nobility of life. Their patterns were grotesque; and they were clad in mighty plate-armor, massive osseous tiles, of quaintly sculpture. It was an armature that spoke unmistakably of crimson conflicts; for, in sooth, these were not "piping times of peace." Next came the Carboniferous age. The area of land is greatly increased; and it is beautified with a new and amazingly luxuriant vegetation. In this plant *régime* the queenliest being is the arborescent fern. And this luxuriant vegetation stores up the solar force, a rich legacy for the far-off but "coming man." At this time a few air-breathers occupy the land. With frog-like affinities, they are of very low reptilian rank.

Passing the Permian and the Jurassic, next comes the Cretaceous age, with the culmination of that reptilian race of monsters of amazing size and most singular aspects. It was, indeed, the companionship of "Beauty and the Beast;" for at this time, also, the nautilus, and the ammonite, those peerless structures of the molluscan life, reveled in beauty and vastness of numbers. But a sad change came, and the gay nautilus tribe was reduced to the merest representation

in the animate scale; while the star of the resplendent ammonite went down in utter death. And there must have been peculiar conditions of both land and sea, in that Cretaceous day, or those strange reptiles of Brobdingnagian altitude could not walk on the land; nor could their aquatic congeners of cetacean bulk, the huge sea-reptiles, move in their briny homes; so with the Ammonites, and the great selachian fishes. But these—the beauties and the monsters—all died, for there came in new conditions of the land, the sea, and the air.

And with these new conditions came the Eocene age, or dawn of the Tertiary epoch of Earth's lifetime. So decided was this physical change, that all things were ready for its reception of a new race of living creatures. The very surface was newly and lavishly garnished, like a table awaiting the expected guests. And the atmosphere had a balmier vigor, a sort of climatal ripeness, like the aroma of an autumnal orchard whose fruit has matured. Now came the true grasses, and the grains; and the Rosaceæ plants with the strawberry, blackberry, apple, cherry, and plum, etc. And Nature's guests arrived, and entered upon the enjoyment of an unrestrained existence in her grand domain. And they were welcome guests; for leading the train came the (as yet) noblest of her begettings, beings of true mammalian rank. They were of new forms and new appetencies. Some were *petite* in size, and some were of more than leviathan proportions, and many were *bizarre* in form; and all were diverse from every thing that had lived before, or that should ever come after. And so each in its own way, as disposition or convenience prompted, enjoyed life. Some preferred the banks of the great rivers, others the grassy meads of the green valleys, and others the sides of the densely-wooded hills. And the timid rodents hid themselves in their burrows at the roar of the carnivores, while both were startled by the beastly bellowing of the great terrestrial behemoths. And these beings, at least some of them, have left their relics in the far West, in places where, until lately, only the red-man had trod.

The geological age just mentioned is called the Tertiary. It was for the first time with true significance sectioned off by Sir Charles Lyell. This learned geologist noticed that this age opened with animal life more like that of the present than any thing that had been before, and that in respect to the molluscs there were many forms identical with existing shells; and he noticed that, as we ascended in this age, the percentage of forms thus similar very rapidly increased. He, therefore, named the bottom section the Eocene, meaning the dawn; and the middle section the Miocene, meaning less of its dawn, that is, farther on in the day; and the highest section he called the Pliocene, meaning still more advanced. To these has been added another, namely, the Pleistocene.

There are three American names which, in respect to the most recent results in vertebrate paleontology, deservedly stand as its

great lights—Prof. Joseph Leidy, Prof. E. D. Cope, and Prof. O. C. Marsh. The last two, with an enthusiasm that has triumphed over great difficulties, have especially produced startling results in their individual explorations of the great graveyards of the ancient dead in our Western Territories. Of the labors of Prof. Cope, as conducted under government auspices, it is proposed here to offer a few results. We shall simply give some details of his work done last summer, as the vertebrate paleontologist in behalf of Prof. F. V. Haydon's "Seventh Annual Report of the United States Geological Survey of the Territories." Prof. Cope found himself literally in a crowded cemetery of a quadrupedal race long extinct.

The list which now immediately follows is limited almost exclusively to the Miocene fossils of "the Bad Lands" of Colorado. It tells a marvelous story of rich and formidable fauna that existed on our virgin continent in that Middle-Tertiary age. The Rodents, or gnawing animals, were well represented. Five genera seem to be established, embracing eighteen species. The predecessors of the squirrels were there. One, named *Paramys*, was a little larger than our chickaree. One little creature, called *Heliscomys*, had four teat-like cusps on the crown of each molar in the lower jaw. This was the tiniest thing of them all, and stood, probably, among the Miocene rodents, as the common mouse does among the gnawers of to-day. If, indeed, *Heliscomys* be the ancestral mouse, our *Mus musculus* has a very ancient pedigree. The rabbits were represented by the genus *Palæologus*.

There are eleven species of Insectivora, arranged under five genera, with the names *Domnina*, *Embasis*, *Miothen*, *Herpetotherium*, and *Isacis*. Except the last one, all these are allied to the mole. They had doubtless the same burrowing habits and food appetencies as the *Talpa* tribe that to-day follows and annoys the gardener at his work. It is an item gained of real knowledge as respects animal habits, to learn that the earthworms and the subterranean larval insects were kept in check in the same manner then as now. And, if these are the predecessors of the *Talpa* race, we would like to know if the primitive stock were as clever engineers at constructing subterranean earthworks, for the mole to-day is a genius in that line. There are six species in the list, and they differ quite a good deal in size; and would seem also to differ in some more important aspects, as the name of the *Herpetotherium* signifies the "crawling beast." It is worthy of remark that these ancient moles, like the modern, were very small animals. Necessarily, then, the fossil bones must have been very minute. They are, however, preserved with wonderful perfection.

As to that other insect-eater, *Isacis*, it represented the existing hedgehog, as shown by its anatomical structure. And as snakes abounded then, probably, like its congeners now, it made many a meal of them, utterly regardless even of those poison fangs, if such they



had. But the great carnivores had a covetous eye on *Isacis*, when it probably rolled itself up in its bristling armature, and, in full consciousness of a *noli me tangere* security, invited its enemy "to kick against the pricks"—in fact, to do his worst. And, doubtless, many a hungry feline, after recklessly accepting the invitation, got very badly worsted. As we shall see, there were little keen-toothed tigers then; but their acquaintance with *Isacis* always ended in disgust, as futile must have been each effort to get a dinner of hedgehog raw. Similar is the experience of our Adirondack catamounts in their attempts on the Canada porcupine. These fierce cats sometimes perish terribly from inflammation caused by the spines of the porcupine, which they are unable to extract.

The carnivorous animals were largely represented. Prof. Cope gives at least ten species. There are five genera of felines, or cats. One of these is quite small, being only half as large as the domestic species; another one, called *Stibarus*, for a cat, seems to have been a rather stout animal. Of these felidæ there are three genera which possessed remarkable saw-edged teeth, painfully suggestive of the carcharodont sharks. Accordingly, one of these is named *Daptophilus squalidens*, which, in plain though somewhat clumsy English, means the "shark-like-devouring lover." We are not from this to think of the grand Mogul, who loved his wives so well that he carved them up; but in metaphysical parlance the phrase must be taken subjectively, as of that absorbing passion where the subject loves to take his victim in—that is to say—one who is as voracious as a shark.

Another of these sabre-toothed tigers had its teeth very strong as well as sharp. "The incisors are very stout, and exhibit slightly curved conic crowns, with a serrulate edge on the inner face." These teeth are more suggestive of the trenchant cutlass than the fine sabre. Though not larger than the existing Canada lynx found in the Adirondack Mountains, this terrible tiger well deserves its fearful name—*Machirodus oreodontis*—the "mountain-like sword-toothed." Another of these carnivores, a new genus, is called *Tomarctus*. It had some relationship to the canines, but, if a dog, it was of very large size, as it probably equaled in this respect our native black bear. There were, however, true dogs then; and some of their remains were secured in the expedition. Their bones, associated with those of the rodents and insectivora, are quite numerous. One species, called Lippincott's *Canis*, was about the size of the coyote, or wolf of the plains. Other species obtained were larger than this; and others again were smaller. A Pliocene mastodon is mentioned, which carries the true Proboscidea far back in time. It is named *Mastodon proavus*, the specific name meaning "before one's grandfather."

Among these Colorado fossils, the ungulates, or hoofed animals, are very prominent. In the advanced classifications of the mammals, the ungulates are divided into the *Perissodactyles*, or those ungulates which

have an uneven number of toes—as the horse with one toe, and the rhinoceros with three—and the *Artiodactyles*, or the ungulates with an even number of toes—as the hippopotamus with four toes, and the hog with its two functional toes. Now, of these fossil ungulates it is remarkable that the expedition has brought home from the Miocene twenty Perissodactyles, and the same number of Artiodactyles; and from the Pliocene nine Perissodactyles, of which four are new, and six Artiodactyles, of which three are new; thus making fifty-three ungulates. Of these there are several horses, and all of them, including *Anchitherium* and *Protohippus*, have three toes to each foot. These cloven-footed beasts were some of them strange, comprehensive types, possessing in the same individual structural resemblances to both swine and deer; “like the latter, these had no horns; they were about as large as sheep. Others were about the size of gray squirrels, being the smallest of this class of animals ever discovered” (*American Naturalist*). Indeed, an important paleontological result has been Prof. Cope’s determination of the correct relationship of five species (three new, and one new genus, *Hypertragulus*) to the musk family. The general reader should perhaps be told that the order *Ungulata*, or hoofed quadrupeds, really absorbs three of the orders in the older classifications, namely, the *Pachydermata*, the *Solidungula*, and the *Ruminantia*. This mentioned, we would say, with no irreverence, that in the Colorado fauna of Tertiary times Nature seemed to indulge, as respects the animals of this order, in the most eccentric extremes of structure, both as to form and size; for some of these hoof-footed ones are scarcely larger than a squirrel, while some are as large as the elephant; and there is a seeming oddity of structure. Though a fact before every one’s eyes, yet many are not aware of its existence, viz., that the ox and cow have no teeth in the front part of the upper jaw. When this animal grazes, the tongue makes a curl, or twist, and pulls in the grass, then the lower front teeth are made to meet the firm pad of the front part of the upper jaw, and the grass is then severed. Such is the mode common to the ruminating animals, that is, those which chew the cud. Now, in the natural group Ruminantia, comes a sub-group, the *Camelidæ*, which includes the camels and the llamas. The dentition of these animals is very aberrant. The upper incisors are not entirely wanting, “there being two canine-like upper incisors, and upper canines as well.” In the Pliocene strata of Colorado are found the remains of two species of camels, of enormous size, and which, strange to say, are furnished with *complete upper incisors*, or front-teeth. These ancient camels, then, did not graze like the ox, but like the horse.

And, among these hoofed creatures, the *Rhinocerotidæ* are represented by three genera. Two of them belong to the Miocene, and the third, the last discovered, to the Pliocene. This is the new genus *Aphelops*, a monster of immense proportions. The other two genera

are *Hyracodon*, and *Aceratherium*. It is remarkable that Prof. Cope has made out seven species of these fossil *Rhinocerotidæ*, which, until the recent discovery of the living hairy-eared rhinoceros (*R. casiotis*) at Chittagong, the northern extremity of the Bay of Bengal, was the precise number of the living species known. It amounts to a certainty, then, that our great Western Tertiary was much richer in species, and immensely richer in individuals of these enormous beasts, than is the whole living fauna of the entire world to-day. And what singular relationships did these *Rhinocerotidæ* hold in those Tertiary times! For there were other animals that held structural alliances with them. One of these the professor has named *Miobasileus*, the Miocene King. This the learned man doubtless did in respectful deference to a notable personage that had died some time before. It was in fact in the Eocene reign that this individual flourished. So the professor refers to him as *Eobasileus*; while another *savant*, deep in the lore of those times, contends that it belongs to a different family. That its place is in the new order *Dinocerata* seems undisputed. What the true dynasty was is not for "the likes of us to say." Besides, we would shudder at any personal attempt to wade this paleontological marsh; and would frankly confess a lack of strength where-withal to cope with a subject so grave as the one which has grown out of these exhumed remains. But, whatever ground there may be as to specific identity or distinction, on these words of Prof. Cope, in his diagnosis of the genus *Eobasileus*, there is full accord: It "indicates a remarkable combination of structure not before known to naturalists. The gigantic size of the typical species (*E. cornutus*) adds to its interest, and shows it to have been the monarch of the remarkable fauna disclosed by recent researches in Wyoming." The genus is "established on remains of five individuals of the average size of the *Mastodon Ohioticus*. . . . From the manner of the occurrence of the relics, this animal probably went in families, or herds," as do the existing elephants.

But it is time to return to his Miocene majesty. It was even with *Eobasileus* much as it has been with other ancient monarchs. He had a wicked way of lifting up his horn. Nay, he lifted them twain; for, owing to an ophthalmic difficulty which seems to have been constitutional—like some modern patriarch, who, when he wants to look upon his household with aspect of authority, doth push his spectacles high up on his head—so this king of the beasts! when he wished to feel,

"I am monarch of all I survey;  
My right (who shall dare) to dispute?"—

that is, when he desired to look up and around, like a king, with brow austere—he tossed those spectacular horns on high, and backward. The fact was, his supremacy lay in his horns. And herein were some disadvantages. "Uneasy is the head that wears a crown." Each

horn was a magnificent affair. But, as sometimes happens with the leading ornament, it was a little awkward in the setting. It was fixed right over the eye! Still, queer as this was, it had its uses. Hereby was achieved a huge bony arch, or cavern, for the protection of the kingly orb beneath—an important provision in case some sturdy old recalcitrant should stand in the way when his majesty went out on a regulation inspection of the royal domain; for, unlike some of his post-relations in Africa and Asia, who are content to take one horn at a time with their compeers, he never took less than two at a bout. In fact, the *Rhinocerotidæ* of the Tertiary age had their horns in pairs; and without doubt they were used in many a pell-mell fight—contests that likely had but little thinking as to the method of the conflict. From this arrangement of the horns in pairs on these creatures, so nearly related to the rhinoceros, the professor with a keen sagacity claims to disprove the statement that horns in pairs show relationship to the ruminants. His own words are: "They present no special marks of affinity to the artiodactyles, and show that the paired horns of the *Eobasileidæ* have no significance in the same direction."

A luminous body, if unobstructed, strews its rays in all directions. And a scientific fact or principle, could our eyes follow the emanations, would be found illuming many if not all other facts in science. It was but lately that the above generalization was reached, when it came forth full-blown from the working out of the new genus *Symborodon*. Of these very remarkable animals the professor gives us six or seven species. And strange beings, even among their contemporaries, must the *Symborodontes* have been. There was *Symborodon bucco*—the last word meaning "the cheeky"—and the fellow had "plenty of cheek." It was certainly so anatomically, and "we" are not speaking metaphorically now. The cheek-bones were enormously developed, so much so that they formed immense osseous masses on each side of his head. Indeed, a blow on the side of his caput would have been simply a capital joke; for how could so unimpressible a skull ever have seen the point? And this same individual comported himself with a ludicrously lofty air, for his eyes were set almost vertically in his head. Perhaps it was the Miocene fashion in the upper ranks to look for something to come down, unlike our Micawber mode of waiting for something to turn up. And this being was nearly as large as an adult elephant. As to what, and how much was his intellectual endowment, we know not. We don't think he was very sharp. But we had forgotten to add this attribute—he had two horns, and they were flat.

Perhaps the Caliban of those strange creatures was *Symborodon altirostris*; not that he was a dwarf among his compeers, for, though not the largest, he was an individual of great weight in his own day. Nor was it that he had a "forehead villainously low;" but because,

on the contrary, he carried a forehead most rascally high, and surmounted by a pair of horns that were murderously straight and sharp. Prof. Cope speaks of this species as the most formidably armed, and as presenting a most *outré* appearance in life. It can be scarcely doubted that his eminence was held in great consideration by the *Symborodon* people, and that they gave him a wide berth when he went out to take a constitutional.

Another of these beasts enjoys the name of *Symborodon trigonocerus*. His horns were three-sided, like a bayonet. To be sure, they were short, and rolled outward, which made them harmless in comparison with the former. This was a large beast, but not so large as *Symborodon bucco*.

The smallest of these creatures was *Symborodon acer*. Poor little fellow! How they must have looked down upon him! He was not as big as the Indian rhinoceros. But he had his own revenge for this condition of sub-mediocrity. His horns were very long and round. Indeed, he could boast of this accomplishment. And it was notable that he always kept the fact plainly before his eyes. He had the longest horns of them all, and carried them one on each side of his nasal extremity; and it was generally understood that, when *Symborodon acer* turned up his nose, he meant mischief.

Speaking of the above group, says Prof. Cope: "Thus it is evident that *Symborodon* is a true perissodactyle, allied to the *Rhinoceri*." To have discovered and worked out this one group alone should give a man glory enough for one lifetime. And yet we are far from having exhausted the list of ungulates. There are *Oreodon*, two species; *Poëbrotherium*, two species; *Septomeryx*, and many others, all cloven-footed beasts; and about these we have said nothing.

But there is still one mammal to be mentioned; and thereby hangs a tail, for it is a monkey. It is a little fellow, but with a big name you may depend, as witness—*Menotherium lemuringum*. Unless his name mislead, he was a nimble beast, and, with the lemur instinct, a night-prowler at that; for his anatomy connects him with the Lemurs, the lowest of the monkeys, and, if we mistake not, there were Nasuan relations also,<sup>1</sup> as with those fossil monkeys obtained by Cope, in the Eocene strata in the Bridger beds on Black's Fork, Wyoming.

Thus much for these new mammals, so remarkable in numbers and character. But the reptiles were largely represented also; for there were serpents, lizards, and turtles, found in those Colorado beds. Of the snakes, one, a *Neurodromicus*, was as large as the black snake;

<sup>1</sup> Both Profs. Marsh and Cope have collected fossil quadrumana from these great Western graveyards. For a remarkable confirmation thus afforded of a generalization made by the present writer, see article "Coati-Mundi," *POPULAR SCIENCE MONTHLY*, December, 1872, page 136, in connection with "Fossil Monkeys," in *idem* for August, 1873, page 519. It is worthy of remark, also, that recent anatomical studies of the Lemurs, by the younger Milne Edwards, afford additional confirmation.

another, a *Calamagras*, was the size of our water-snake; while another, of the same genus, was about as large as a garter-snake. Of these ophidians, all the species and three of the genera are new to science. One thing is observable in Nature—the provision made for sustaining the proper balance, by keeping in check that which might become in excess. It is plain that the moles were very numerous. But these and their congeners were not relished by the mammalian carnivores. The bad smell of the shrew prevents the cat from eating it. Probably the snakes were less dainty, and herein, perhaps, lay their utility in the animal economy. It might seem that Prof. Cope had assigned to the ophidia a similar task, as he names one species *Aphelopsis talpivorus*, which simply means the mole-eating *Aphelopsis*.

The Lacertilia, or lizards, furnish some interesting traits. Prof. Cope gives six characteristically separated genera, and all are new. *Exostinus* and *Peltosaurus* were lizards with bony shields, and symmetrical bony tubercles on the head. Here comes in an interesting fact for science, namely, that this is the first time that the ophidia and lizards have been found in the Miocene strata of America.

The turtles are represented by several species, which, although new, present no features of popular interest.

We will now give some facts pertaining to this work of the Geologists in the Territories.

There were really three expeditions made last summer, one to the "Bad Lands" of Colorado, one to the "Bad Lands" of Wyoming, and the third to the Cretaceous formation of Kansas.

As respects the "Bad Lands" of Colorado: three distinct geological formations were found superimposed, or lying in sequence. First, at the base was a series of strata containing fossil wood. This was Cretaceous, and was known as the "Lignite Division." Next came strata known as the "White River Division." This was Miocene. The next was the "Loup Fork Division," and this was Pliocene. Of course, speaking geologically, this was top of all.

In the Pliocene the fossils found were twenty-four species, of which ten were new to science. They embraced four carnivora, one proboscidian, a mammoth, seventeen ungulates, of which two were great camels. With these ungulates were a number of Pliocene horses. Two interesting facts were obtained: one, that all the horses had three toes to one foot, and the other that the camels had full sets of incisor teeth in both jaws. In this formation was found the large rhinoceros, *Aphelops*.

From the Miocene were obtained: rodents, eighteen species; insectivora, eleven; carnivora, ten; perissodactyles, twenty; artiodactyles, twenty—thus making forty ungulates; quadrumana, one; lacertilia, or lizards, seven; ophidia, five; turtles, five. Probably the following may be set down as the chief results growing out of the



Miocene harvest: The first is the discovery of monkey remains; the discovery of snakes and lizards in American Miocene, and related to the corresponding genera of the Eocene of Wyoming Territory; the settlement of the correct relations of five species, of which three species and one genus, *Hypertragulus*, were new, the relation being to *Moschidæ*, or the musk-deer family; the determination of the genus *Symborodon*, as allied to the rhinoceros on the one side, and to *Eobasilus* on the other; the discovery of numerous insectivora, allied to the mole. Such is an epitome of the results of the summer's work in Colorado.

In Wyoming Territory occurred the fact so highly important to stratigraphical geology—the discovery of the Bridger strata of fossils just above the coal at Evanston. This fixed the age of the deposit geologically, a fact of primary importance to the geologist; the discovery of the new genus, *Anchænodon*, an animal near to the swine animals of the genus *Elotherium*, also allied to *Anthracotherium* of Europe; the discovery of the large animal *A. insolens*; also of long canine tusks of *Bathmodon*.

In Kansas numerous fishes and reptiles were discovered. One of these was the saurodont (lizard-toothed) fish, *Portheus gladius*. This creature was terrible. He had a pectoral spine which he could elevate at pleasure, and it was four feet long.

Thus we have for a summer's work, by Prof. Cope, not less than 150 species of vertebrate animals alone, of which 100 are new. This makes no account of the collections of the invertebrates. "There is a view generally entertained by naturalists and geologists, that genera and species of animals and plants are greatly more numerous at the present age of the world than in any previous geological period. This seems to me an entire misconception of the character and diversity of the fossils which have been discovered in the different geological formations." So wrote the lamented Agassiz just twenty years ago. Surely there can be no uncertain opinion on that subject now. "Prof. Cope has obtained from the ancient sea and lake deposits of Kansas, Colorado, Wyoming, Idaho, etc., about 350 species of vertebrated animals, of which he has made known to science for the first time more than 200 species!"

Profoundly and alike wonderful, then, to philosopher and naturalist is this story of the irrevocable extinction of entire races of animals. And the same earth-area of that wellnigh fabulous land has seen even greater things than these; for, both before and since the historic age began, it has beheld the passing away, into the darkest dimness of tradition, whole tribes and languages of men.

SCIENCE, EDUCATION, AND ARISTOCRACY.<sup>1</sup>

THERE could be no doubt that, in the age in which it was their lot to live, the tendency of education ran toward science and abstract science, and every man who was interested in the fortunes of his generation would naturally ask himself the question what the effect of such scientific teaching was likely to be, what it would be still more likely to produce, if it rose to absolute predominance, and whether it would raise or lower, soften or harden, those upon whom it was brought to bear. As he said before, no reasonable man could doubt that the tendency of the age was to make scientific teaching the predominant study. The greatest of philosophical writers would admit that was so. That which followed the main teaching of former times—the great arts of sculpture, painting, writing, oratory, and the like—all comparatively sank before the abstract science of the present day. Compare for one moment the range of teaching in the middle ages with the present circles of learning. In the tenth century Pope Gebert was said to embrace within himself all the knowledge of the time; but let any one contrast his attainments, great as they were, with the correlation of arts now practised, and the enlarged field over which modern science ranged. There was undoubtedly a vast difference between the two states of things. When they looked at the present state of scientific education they might fairly distinguish three different classes of persons to whom it might be applied. First, there were those like the late Mr. Brassey, great captains of labor, who led men not only over Europe, but over every quarter of the globe, and changed the whole face of the earth by their vast engineering power and skill. Secondly, there were those among them at the present day who saw only through the eyes of material philosophy, who accepted that material philosophy and scientific teaching as their surest and safest standard and guide, who reduced most things to it and judged most things by it, but whose minds were nevertheless open to other considerations, and who did not feel that it was the sole and exclusive standard of their lives. To both those classes what he was about to say did not apply. There was, however, a third class who were tempted to reduce every thing to the one standard of science—who knew no other law and applied no other rule, not only to science itself, but to all the other conditions of life and action. To such a class, though he alluded to no one in particular, his observations would, he thought, apply. When science was pushed to that extreme its professors would not be the best rulers for mankind, and he, for one, should regret to see the affairs of men regulated solely by such a

<sup>1</sup> Extract from an address of Lord Carnarvon before the London Birkbeck Institution, with comments thereupon by "J. H. L.," of the *London Examiner*.

standard as they would apply. If such views as they held were pushed to an extreme, he could scarcely imagine a Pharisee more arrogant, a Sadducee more self-opinioned, a fanatical monk of the middle ages more intolerant than they who practised them were likely to be.

He might be asked the reason for all this. Some might say it was a reaction from the extreme dogmatism of past times; and it was undoubtedly true, as every careful student of history would admit, that there had been an excess of dogmatism in former days. Theology, for instance, had encroached upon the fair and reasonable domain of science, had sometimes thrown obstacles in its way, and had subordinated science to most mistaken and unreasonable interpretations of Scripture. On the other hand, there was now a risk that science might possibly encroach a little on the domain of theology. At all events, it seemed to him there were reasons why what he had just now said should be the case. In the first place, unlike other studies, it must always be remembered that the conclusions of abstract science were demonstrable. Those who dealt in them were so satisfied of their certainty that they could not accept any conjecture or doubt on the point. There were branches of science in which that was perfectly true, as in the case of mathematics, where in certain propositions no reasonable man, applying the ordinary laws of thought, could doubt certain results—such, for instance, as that two and two were four. There were other branches to which that did not equally apply, but one thing was certain—that those who would carry that frame of mind into the complex relations of human life, into political and social philosophy, and into all the relations which affect men one toward another, were applying a standard which was wholly impracticable, and which would ultimately lead to mere confusion.

In the next place, he would again say that, unlike other studies, mere hard, abstract science did divorce itself from literature, and almost repudiated religion; and he thought no man who looked back over the varied course not only of the middle age history, but of the whole history of the world and of mankind, could doubt that, whatever might have been their shortcomings, defects, and excesses, men owed to the influence of literature and religion far more than they could express, far more than they were likely to admit, and far more than he could attempt to describe on that occasion. At all events, they had exercised the softest and most refining influence upon mankind. Undesirable as it was for men that any one intellectual power, so to speak, should exert an exclusive rule over them, or enjoy a monopoly of authority, he freely admitted that he would prefer the authority of literature and the arts to that of mere pure, hard, abstract science. Art had been well termed “the handmaid of religion,” and literature had formed a republic of letters; and their rule, though variable, unjust, and even unequal, would not be the grinding, rigid

despotism, and would not impose that yoke, which hard, abstract science would.

He might be asked why he entertained that great dread of scientific men as the ultimate rulers of a community. He was not blind to their great merits, or to the vast intellectual power which they wielded daily more and more, and he was neither out of sympathy with them nor were their subjects uncongenial; but, as he dreaded a monopoly of power by any one class, so he especially dreaded it in their hands. He believed that abstract science, so to speak, was very often devoid of the milk of human kindness and sympathy, and he would quote an illustration of what he meant from one of the most remarkable and touching books he had ever read—"The Autobiography of John Stuart Mill." He should be sorry to take Mr. Mill as a representative of hard, abstract science, for throughout his nature there ran veins of feeling softer and more tender than he was willing himself to allow. But he quoted that book for the moment as one of the fairest illustrations of the action of the philosophical mind in these matters. Those who had read it would remember how carefully Mr. Mill, partly under the influence of his father and partly through his self-education, endeavored not merely to suppress but to trample down and to crush out every thing approaching to feeling in his nature. In that respect he was utterly unlike Bishop Butler, who held that the feelings were of the best and most indispensable parts of the human system. He remembered that so far did Mr. Mill carry his theory into practice that he took the opportunity of stating that in his opinion it would be indefensible for an educated man to enter the same room as an uneducated man except he were the apostle of some creed that he was about to propagate. He could conceive nothing more selfish or more subversive of all the principles on which all society existed than that doctrine. He remembered the story of a conversation related by Southey between Sir Humphrey Davy and Faraday, in which the latter, then a young man, told Davy that he was anxious to join in the pursuits of science because its professors were more likely than others to be of a liberal cast of mind. Davy smiled mournfully, and replied that, whatever science might be, it did not of itself convey that liberality of mind which Faraday so fondly imagined for it. Lord Carnarvon objected to the application of those rules, which naturally and rightly governed abstract science, to legislation, morals, social life—in fact, to every thing which concerned the existence of man. Some would remember that in the years 1848 and 1849, when all the Continent was disturbed, when thrones were laid in the dust and kingdoms shaken, a group of all the most eminent philosophers of the time met in Frankfort to review the condition of affairs, and they would recollect the very unsatisfactory conclusions at which they arrived.

Auguste Comte, whose name was so great abroad, founded a philosophy which contemplated the transfer of all those powers hitherto

exercised by priests and sacerdotal parties to the philosophical class, but he was obliged, in constructing his theory, to form a sort of corporate hierarchy and invest them with the very powers taken from those whom he had so strongly denounced. In so doing, as Mill in an early book had said, he had furnished "a monumental warning" to those who dealt with such matters. Science itself, however speculative a range it might take, could not naturally be pregnant with the tender and softer feelings unless it was coupled with altogether different principles, which would enable it to be applied to the affairs of mankind. Look back for a moment on the different forms which science had sometimes taken. In the middle ages "Italian cruelty" was a proverb. Italy, which could then count more men of science than the rest of Europe, was not hindered on that account from also claiming a monopoly of cruelty. Chaucer threw out the same sneer at scientific men of his day, and during that time there arose that curious and mysterious combination of poisoners in Europe who united science with no tenderness of heart. Science, therefore, he thought, was no safeguard or guarantee of itself for tenderness and affection, but when joined with something higher in the human system it would call into play all the highest qualities of the mind, and assert an intellectual and moral domain in which the greatest of men could serve.

---

THE speech delivered on December 6, 1873, by the Earl of Carnarvon, at the Birkbeck Institution, is a very significant indication of the progress of public opinion, at all events in one direction, during the last half-century. Fifty years have passed away since the late Dr. Birkbeck, aided by a small band of the ultra-Radicals of his day, founded the Mechanics' Institute in Southampton Buildings. The work was begun and carried on amid the howls, and execrations, and sinister prophecies of those "upper" classes whose lordly representative came down, a week ago, to smile his approval upon its success, and to hallow it with a patrician benediction. No words were too hard for the revolutionist and heretic whose profanity had reached such a pitch that he dared to encourage working-men to learn something besides the Church Catechism. Here was a man—and, strange to say, a gentleman—acting on the assumption that the horny-handed and ill-smelling laborer had a mind which ought to be cultivated, had a life which ought to be lived for some other purpose than that of making his "betters" comfortable. Worse still, he did not hold it as a theory to be dilated upon on Sundays from a pulpit, and to be realized on the other side of the grave; but, to the horror of the Newdegates and Tomnoddies of 1823, he actually went and set up an institution in which science—"hard, abstract science"—might be taught to the "great unwashed." No wonder that a noble-minded aristocracy held

their faces half averted and their eyes half closed at the contemplation of such enormity. No wonder that our established clergy raised their smoothly-shaven chins in meek abhorrence of such impiety, and displayed their white neckcloths, the emblems of the pure sentiments which surged beneath. Perhaps the strangest thing in the whole of this history—and it shows that there must be something radically wrong in the constitution of the universe—is that this wicked enterprise weathered the storm, and that the parent institution is by far the most important educational establishment for adults in the metropolis, while its progeny may be found thriving in almost every provincial town of any size throughout Great Britain. Tell it not in Gath, publish it not in the streets of Askelon. Here is an educational institution which, without any help from nobleman or priest—save that which they conferred by staying away—is not only succeeding, but getting over the “religious” difficulty by leaving theology to be taught elsewhere, and solving the problem of female education by simply opening its doors on equal terms to men and women. This “godless” college is now educating 2,712 students of both sexes; its curriculum is as wide and its teaching as thorough as that of any institution with which we are acquainted; and so completely have the bogies which frighten the outside educational world been exorcised, that even a thought of them never seems to cross the minds of the students who, after their day’s toil, come down to instruct themselves in literature, science, and art, and to take part in the management of their *alma mater*.

How was it that Lord Carnarvon cast his benignant smile on such an institution? Times, it is said, change; and we change with them. Has the leopard of obscurantism, then, changed his spots? His lordship’s speech furnishes a complete answer to this. It shows that the Tory oligarchs are as thoroughly opposed as ever they were to the work of education. They are acting over again the old fable of the sun and the wind. Force has failed, and they are trying to gain the same end by persuasion. The difference is purely one of engineering. They have tried the granite wall of direct resistance only to find it shattered by the heavy artillery of the democracy, and their hope is now in the yielding earthwork of patronage. Lord Carnarvon and his compeers love popular education as the Duc de Broglie loves parliamentary government. They will resist giving it at all as long as possible; and, when this cannot be done, they will push themselves to the front and undertake the supply of the article, taking care to do as fraudulent tradesmen do with their milk, skimming as much of the cream off, and adding as much water, as they can without being detected.

The whole gist of Lord Carnarvon’s address was an attack on scientific education. Not that he objects to science if kept within proper bounds. He does not find fault with “those like the late Mr.



Brassey, great captains of labor, who led men not only over Europe, but over every quarter of the globe, and changed the whole face of the earth by their vast engineering power and skill." Not being a "materialist," this is the kind of science his lordship likes best. Next, there is a class of scientific men who accept "material philosophy and scientific teaching as their surest and safest standard and guide . . . . but whose minds were nevertheless open to other considerations, and who did not feel it was the sole and exclusive standard of their lives." As science tempered by "other considerations" would be acceptable to Pope Pius himself, we need not be surprised that to this Lord Carnarvon has no objection. It is for a third class of scientific men he reserves his denunciation. There is, it appears, a class—if, indeed, so small a body of men can be called a class—who carry the scientific frame of mind "into the complex relations of human life, into politics and social philosophy, and into all the relations which affect men toward one another." The influence of this little class is growing, Lord Carnarvon tells us; and we are convinced that he is right. Now, at this he is very much terrified. If only those naughty scientific men would keep to engineering and physics, his lordship would not care; but what he objects to is "the application of those rules, which naturally and rightly govern abstract science, to legislation, morals, social life." In other words, scientific men may settle the distance of the sun from the earth at what figure they like, and they may build bridges and construct railroads; but, if they apply the same logical processes which they have found serve them so well in the material world to the solution of social and political problems, this is really too much for patrician nerves. There is a hardness about the scientific method which Lord Carnarvon does not like. If it were not for this diabolical device, we might come to any conclusions on social matters which fit in with our predilections or interests; but, with the "grinding, rigid despotism" of logic, this is impossible. All that manly independence of our premisses which occasionally characterizes our conclusions on political matters would be gone forever, and "one intellectual power" would "exert an exclusive rule over" us.

Lord Carnarvon did not content himself with a mere depreciation of social and political science, but attempted to point out its shortcomings. It is, he thinks, "devoid of the milk of human kindness." This is quite true, and a much wider truth than stated. It is as true of the multiplication-table as of scientific politics. But, when Lord Carnarvon, showing a little of that individual freedom which he despairs of keeping, argues that, because science is "no safeguard or guarantee of itself for tenderness and affection," therefore, those who are thoroughly imbued with the scientific spirit trample on and despise affection and tenderness for their fellow-creatures, he is appealing to one of the most foolish of prejudices in support of one of the most disingenuous of arguments. The love of truth, for its own sake,

which is popularly confounded with "hardness," is in no way bound up with want of sympathy or kindness; but people are so used to carry their sentiments into the decision of questions of fact, that when they find any one does not do so, they conclude that he is without feeling. Nothing could be a clearer proof of this than the instance brought forward by Lord Carnarvon. Mr. Mill, he says, "endeavored not merely to suppress but to trample down and to crush out every thing approaching to feeling in his nature." That this should be said of the most tender of husbands, the kindest of friends, the man whose sympathies were as wide as the animal creation, whose depth of feeling was such that there was not a noble or a beautiful thing in Nature but it mirrored itself on his heart—is convincing evidence of the utter blindness of Lord Carnarvon in the discernment of sentiment in others which takes a different direction from his own. What Mr. Mill did with unequalled success was that which we have already indicated. He endeavored, when engaged in the investigation of truth, to avoid the bias of sentiment; but it needs no prophet to tell us that in this he was impelled by a loyalty to truth springing out of his conviction of its importance to the interests of his kind. Indeed, if thoroughly scientific men were as devoid of feeling as Lord Carnarvon represented them, his fear of them would be ludicrous. They are a mere handful of men. They have arrayed against them the prejudices of mankind, the interests of the ruling classes all over Europe, and a powerful and well-paid ecclesiastical organization. What reason is there to be in "great dread" that a few men without feeling or devotion will triumph over such great odds? The truth is, that what is making the wearers of coronets and mitres tremble is, not the absence of religious feeling from social philosophy, but the union of the two. Mr. Mill has done more than any one in modern times to effect that union. It shines through his works on even the most abstract of subjects as a halo, and deep in the hearts of the most powerful intellects of our country are to be found the sentiments which he did so much to rouse and to direct. Hence these tears.

---

#### SKETCH OF R. A. PROCTOR.

IN making use of the sciences for purposes of intellectual cultivation, a distinction has been drawn between those that are fixed, or established, and those that are progressive, and it has been maintained that the former alone are to be admitted for the purposes of mental training. Foremost among these are Mathematics, Astronomy, and Molar Physics, or the laws of the motion of masses. These may be introduced as means of scientific education, while Molecular Physics, Chemistry, and Biology, from their unsettled character, are alleged

to be unfit for such employment. There are no doubt reasons for this distinction, whether conclusive or not, but the classification is by no means above criticism, for within our own time Astronomy has been taken out of the category of the established or perfect sciences, and may be now cited as one of the best illustrations of a progressive science. Of course, there are established truths in Astronomy, and so there are in Chemistry and Physics, but Astronomy has now assumed a new character of progressiveness, and within the present generation it has surpassed all the other sciences in the rapidity and splendor of its advancement.

Not so many years ago it seemed as though astronomy were approaching, if it had not already reached, its final stage. The Sun and his family had been measured and weighed, the Moon tracked in all her motions, and the paths of comets determined. The younger Herschel had completed the survey of the heavens, which his father commenced, and, to all seeming, little remained to be ascertained about the universe. And yet, in the presence of the astronomy of our day, that of a few years ago looks crude and elementary. Newton made an epoch by bringing the movements of the planetary bodies under the demonstrated laws of terrestrial force; Kirchhoff and the spectroscopists have made a new era by subordinating stars, comets, and nebulae, to the laws of terrestrial chemistry. The recent physical explorations of the sun constitute one of the most thrilling chapters in all science. Nor have astronomers been content with the unquestioned acceptance of the older views respecting the planetary scheme. Not Ptolemy alone, or Hipparchus, Galileo, Kepler, and Newton, but even the elder and younger Herschel, would stand aghast at the change of opinion that has been wrought regarding the members of the solar system. Jupiter and Saturn, so long considered as merely large specimens of habitable worlds, have taken their place in a higher order of orbs, while satellites, formerly thought to be set as lights to illumine their primaries, have been raised almost to the dignity of planets. Even more surprising have been the discoveries made respecting comets and meteors, while modern inquiries have not stopped short of the domain of the so-called fixed stars, so that the whole scheme of the stellar universe begins to present a new aspect.

Astronomical science, in short, has been enlarged and reshaped in the nature and scope of its problems, and has entered into a new epoch in our own time which opens to us even a grander future than was disclosed either to Copernicus or to Newton.

As was quite unavoidable, this recent revolution or extension of the science has left behind the old teachers, and created a demand for new men, who can deal with the subject in its more novel and extended aspects. And, as supply follows demand in the intellectual as well as the commercial world, the expounders of the new dispensation

are forthcoming as required. Eminent among these is the subject of the present sketch, who has come over from England to lecture upon astronomical subjects. Ten years ago he was unknown, but within that time he has won a prominent position both as an investigator of celestial phenomena, and as an eloquent and instructive writer upon the most modern phases of the science. Of his wonderful industry and remarkable versatility the following sketch will furnish abundant evidence, but we were hardly prepared to expect that Mr. Proctor would sustain his eminent reputation in the new field of popular lecturing, yet such is the fact. He is an easy and fluent extemporaneous speaker, enthusiastic over his themes, and wielding his large resources of knowledge with the utmost facility and readiness. Dealing with the sublimest of all subjects in its latest and most novel aspects, he carries his audience with him, and occupies their attention so completely that they lose the sense of time, and reach the close of a long lecture under the impression that it is but fairly begun.

RICHARD ANTHONY PROCTOR was born at Chelsea, March 23, 1837, and is consequently not yet thirty-seven years of age. He was educated in his boyhood chiefly at home, being delicate in health. He was a diligent reader, his tastes inclining to history, literature, and theology, more than to mathematics or the sciences. He showed a great liking for the construction of maps, and still regards charting not only as an important aid in scientific investigation, but as a very instructive mental exercise. At the age of twelve he began to read Euclid in school, and at once took to geometrical study. At thirteen his father died, and the boy soon after left school. He was now a ward in chancery; and it affords a good illustration of the system attacked by Dickens in "Bleak House" that, although there was not any "suit" properly so called, Mrs. Proctor was engaged for three or four years in an expensive series of legal processes, the sole object of which was to assign to her formally on behalf of her children the proceeds of a certain estate of which they were heirs.

In 1854 young Proctor obtained a clerkship in a bank to aid him in getting the means of going to the university, as he was designed for a clergyman in the English Church. But little time was allowed for study; but when, in 1855, he went to King's College, London, he succeeded in taking first place in seven subjects—classics, mathematics, history, literature, divinity, French, and German. In 1856 he entered St. John's College, Cambridge, where he distinguished himself in mathematics. In 1857 he lost his mother, for whose sake alone he had valued college successes; and he no longer pursued his mathematical studies, though he remained at Cambridge, and took the degree of B. A. in 1860.

Although he went into the Cambridge Senate House for examination, after two years of mathematical idleness, and without any acquaintance with the higher and more important branches of mathemati-

cal reading, Mr. Proctor is reported as standing high in the university among the "wranglers." We have wranglers in this country, and keep a whole Congress of them for public exhibition, as gladiators were exhibited at the Roman shows. But in the English universities this term is applied to a limited group of first-class students or honor-men who go in on the final scramble for the highest places in a numerical gradation. He who beats all the rest is called "senior wrangler." This is the highest position of university honor, and the struggle to reach it is so long and severe that it is said to "use up" the successful candidate, so that the "senior wrangler" is rarely heard of in after-life. Then come second, third, and fourth wrangler, and so on, and even tenth wrangler is regarded as a highly-honorable rank, as in fact it is to be a wrangler at all. Fortunately for astronomy and American lecturing, Proctor did not win the headship in the wrangle of his year, but he is quoted as being close on the heels of the leaders.

Mr. Proctor's first literary effort, a nine-page article on "Double Stars," appeared in the *Cornhill Magazine* for December, 1863, ten years ago. His next attempt was an "Essay on the Rings of Saturn," which was declined, as not sufficiently popular for the readers of the *Cornhill Magazine*. This led to the writing of his first book, "Saturn and its System," a work chiefly remarkable for the fullness of the relations presented by a single planet, which are discussed in almost every conceivable aspect. The construction of maps to illustrate Saturn led Mr. Proctor to form his "Gnomonic Star Atlas," planned on an altogether original system. The sphere is supposed to be inclosed in a dodecahedron, on whose twelve pentagonal faces the stars are projected. A third work, called "The Handbook of the Stars," was also ready for the press in 1866. In this year an event occurred which rendered literary and scientific labor, hitherto pursued as an amusement, a necessity of existence. The bank in which he had all his fortune broke and left him worse than bankrupt, for he was liable for many thousand pounds, and from this liability he has but very recently obtained release. The three years following were marked with struggles, difficulties, and severe domestic bereavements, which interrupted literary work. In 1867 "Constellation-Seasons" (now out of print), and "Sun Views of the Earth," were produced, as well as charts of the planetary orbits, projections of Mars, and other maps. In 1868 appeared "Half-Hours with the Telescope," and in 1869 "Half-Hours with the Stars." But the chief occupation of Mr. Proctor's time for the three years consisted in essay-writing for the magazines, and in the preparation of works which publishers rejected at the time, but which have since met with a success altogether unusual in scientific literature.

In 1868 Mr. Proctor commenced writing popular science essays for the London *Daily News*, and has continued to do so until the present time. In 1870 appeared "Other Worlds than Ours," which had a

prompt and remarkable success, and in the same year his large "Star Atlas" was published. Early in 1871 "The Sun" was printed, and was also well received. In the same year appeared "Elementary Lessons in Astronomy," and the first series of "Light Science for Leisure Hours;" in 1872 the "School Atlas of Astronomy," "Essays on Astronomy," "Orbs around Us," and "Elementary Lessons in Physical Geography." Much of his time this year was devoted to the construction of a chart, showing all the stars visible in the northern heavens with the telescopes  $2\frac{3}{4}$  inches in aperture—in all, 324,198 stars. This chart exhibits relations having an important bearing on our ideas respecting the constitution of the heavens. During the past year Mr. Proctor has published the second series of "Light Science," "The Moon," "The Border-land of Science," "The Expanse of Heaven;" and a new work, entitled "The Universe and the Coming Transits," is now passing through the press.

Such a rapid multiplication of books cannot of course be otherwise than unfavorable to the promotion of science by original research. This Mr. Proctor recognizes, and he has described it as one of the principal hardships occasioned by the loss of his property, that he was compelled to give but a limited portion of his time to original investigations. But, although driven to write about science for a livelihood, or to forsake it altogether for more remunerative employment, he is very far from having neglected the more serious work of research. Few know what can be accomplished by industry and perseverance. It is only necessary to look over the index of the Proceedings of the Royal Astronomical Society to see that Mr. Proctor has been a large contributor to its work. Indeed, although its pages are limited to the record of such work, from 1868 to 1873 Mr. Proctor contributed to these proceedings more freely than any fellow of the Astronomical Society. His papers have related chiefly to the stellar system, the laws of distribution of stars, their motions, the relations between stars and nebulæ, and the general constitution of the heavens. But the subject of the solar corona has occupied a considerable space among Mr. Proctor's papers, while even a larger amount of labor has been given to the investigation of the opportunities which will be presented during the transits of Venus, on December 9, 1874, and December 6, 1882.

The subject of that mysterious connection between meteors and comets which forms one of the most surprising of the results of modern observation has also been largely dealt with by Mr. Proctor. His investigation of the rotation-period of the planet Mars, resulting in a value certainly within one-tenth of a second of the true period, may also be mentioned among his original researches.

It is but just to say that Mr. Proctor has been singularly fortunate in enunciating theories which have been subsequently confirmed, and in some cases demonstrated by new observations. His confident tone



respecting the solar theory of the corona in 1870 and 1871 was blamed by some and misunderstood by many, who failed to perceive his reason for urging arguments so strongly on a matter seemingly theoretical. That reason was stated by Mr. Proctor in the preface to the first edition of the "Other Worlds," where he expresses his anxiety lest doubt and confusion, prevailing as to a matter really demonstrated, might cause the opportunities presented by the great solar eclipses of 1870 and 1871 to be frittered away. Mr. Proctor's confidence on the one hand and his anxiety on the other were fully justified by the event. Every astronomer now accepts the solar theory of the corona, and few are ignorant how, at the eclipse of 1871, two-thirds of the observers were set by the chief believer in the terrestrial theory to make observations which proved nothing, and which, but for faith in that exploded theory, would never have been thought of.

The controversy respecting the transits of Venus, begun in 1869, and brought to a close quite recently, led to unpleasant relations between Mr. Proctor and the Astronomer Royal. Indeed, it must be admitted that in conducting this controversy after February, 1873, Mr. Proctor exhibited a zeal which at times seemed uncalled for. But some explanation may be found in the fact that, having remained quiescent, at the Astronomer Royal's special request, for a long time, his renewal of the discussion led immediately to the statement that it was now too late for any change of plan. Fortunately, the results of the inquiries of American, Russian, and German astronomers, as well as the nature of the schemes proposed by them, fortified Mr. Proctor's position; and, even while the Astronomer Royal was proclaiming his conviction that no other nation would adopt the same opinions as Mr. Proctor, news reached England that America, Russia, and Germany, were in accord in these matters. It cannot be wondered at that, at the Greenwich Board of Visitation, Prof. Adams proposed, and the Board unanimously voted, the point which Mr. Proctor had urged in 1869, viz., that it was desirable to apply Halley's method (respecting which Airy had said, in December, 1868, that it "failed totally"). In this matter, as in the controversy respecting the sun's corona—the only controversies in which Mr. Proctor has engaged—there was this obvious reason for pressing the discussion, that eclipses and transits will wait for no man. In his main subject of original investigation—the constitution of the heavens—Mr. Proctor has wisely avoided controversy, contenting himself with advancing and advocating his views, collecting evidence, weighing objections, and endeavoring to progress toward the solution of the difficult but interesting problems associated with the subject.

## CORRESPONDENCE.

MR. GLADSTONE CORRECTS MR. SPENCER.

IN reply to Herbert Spencer's last paper on the "Study of Sociology" (in POPULAR SCIENCE MONTHLY for December, 1873, p. 134), Mr. Gladstone sent the following letter to the editor of the *Contemporary Review*:

10 DOWNING STREET, WHITEHALL, }  
November 3, 1873. }

MY DEAR SIR: I observe in the *Contemporary Review* for October, p. 670, that the following words are quoted from an address of mine at Liverpool:

"Upon the ground of what is termed evolution, God is relieved of the labor of creation: in the name of unchangeable laws, He is discharged from governing the world."

The distinguished writer in the *Review* says that by these words I have made myself so conspicuously the champion (or exponent) of the anti-scientific view, that the words may be regarded as typical.

To go as directly as may be to my point, I consider this judgment upon my declaration to be founded on an assumption or belief that it contains a condemnation of evolution, and of the doctrine of unchangeable laws. I submit that it contains no such thing. Let me illustrate by saying, What if I wrote as follows:

"Upon the ground of what is termed liberty, flagrant crimes have been committed: and (likewise) in the name of law and order, human rights have been trodden under foot."

I should not by thus writing condemn liberty, or condemn law and order; but condemn only the inferences that men draw, or say they draw, from them. Up to that point the parallel is exact: and I hope it will be seen that Mr. Spencer has inadvertently put upon my words a meaning they do not bear.

Using the parallel thus far for the sake of clearness, I carry it no farther. For while I am ready to give in my adhesion to liberty, and likewise to law and order, on

evolution and on unchangeable laws I had rather be excused.

The words with which I think Madame de Staël ends "Corinne," are the best for me: "*Je ne veux ni la blâmer, ni l'absoudre.*" Before I could presume to give an opinion on evolution, or on unchangeable laws, I should wish to know, more clearly and more fully than I yet know, the meaning attached to those phrases by the chief apostles of the doctrines: and very likely, even after accomplishing this preliminary stage, I might find myself insufficiently supplied with the knowledge required to draw the line between true and false.

I have, then, no repugnance to any conclusions whatever, legitimately arising upon well-ascertained facts or well-tested reasonings: and my complaint is that the functions of the Almighty as Creator and Governor of the world are denied upon grounds, which, whatever be the extension given to the phrases I have quoted, appear to me to be utterly and manifestly insufficient to warrant such denial.

I am desirous to liberate myself from a supposition alien, I think, to my whole habit of mind and life. But I do not desire to effect this by the method of controversy; and if Mr. Spencer does not see, or does not think, that he has mistaken the meaning of my words, I have no more darts to throw; and will do myself, indeed, the pleasure of concluding with a frank avowal that his manner of handling what he must naturally consider to be a gross piece of folly is as far as possible from being offensive.

Believe me, most faithfully yours,

W. E. GLADSTONE.

MR. SPENCER ON THE CORRECTION.

To the second edition of Mr. Spencer's "Study of Sociology," he appends the foregoing letter, and remarks as follows (page 425):

Mr. Gladstone's explanation of his own meaning must, of course, be accepted; and,

inserting a special reference to it in the stereotype-plate, I here append his letter, that the reader may not be misled by my comments. Paying due respect to Mr. Gladstone's wish to avoid controversy, I will say no more here than seems needful to excuse myself for having misconstrued his words. "Evolution," as I understand it, and "creation," as usually understood, are mutually exclusive: if there has been that special formation and adjustment commonly meant by creation, there has not been evolution; if there has been evolution, there has not been special creation. Similarly, unchangeable laws, as conceived by a man of science, negative the current conception of divine government, which implies interferences or special providences: if the laws are unchangeable, they are never traversed by divine volitions suspending them: if God alters the predetermined course of things from time to time, the laws are not unchangeable. I assumed that Mr. Gladstone used the terms in these mutually-exclusive senses; but my assumption appears to have been a wrong one. This is manifest to me on reading what he instances as parallel antitheses; seeing that the terms of his parallel antitheses are not mutually exclusive. That which excludes "liberty," and is excluded by it, is despotism; and that which excludes "law and order," and is excluded by them, is anarchy. Were these mutually-exclusive conceptions used, Mr. Gladstone's parallel would be transformed thus:

"Upon the ground of what is termed liberty, there has been rebellion against despotism: and (likewise) in the name of law and order, anarchy has been striven against."

As this is the parallel Mr. Gladstone would have drawn had the words of his statement been used in the senses I supposed, it is clear that I misconceived the meanings he gave to them; and I must, therefore, ask the reader to be on his guard against a kindred misconception.

I have not, however, thought it needful to change the description given of Mr. Gladstone's position, or to suppress the comments made upon it; because the substantial truth of this description is shown by the other passage quoted, the manifest meaning of which he does not disclaim.

By characterizing Science as having "gone to war with Providence"—by displaying an unhesitating belief that great men are providentially raised up at the needful times, and by speaking with alarm and reprobation of the belief that their rise is due solely to natural causes, Mr. Gladstone does, I think, give me adequate warrant for taking his view as typical of the anti-scientific view in general—at any rate, in so far as the Social Science is concerned. Though this view may not be incongruous with the conception he entertains of Science, yet it is certainly incongruous with the conception entertained by scientific men; who daily add to the evidence, already overwhelming, that the Power manifested to us throughout the Universe, from the movements of stars to the unfolding of individual men and the formation of public opinions, is a Power which, amid infinite multiformities and complexities, works in ways that are absolutely uniform.

---

#### NOTE ON THE PHYSICAL CONSTITUTION OF MATTER.

*To the Editor of the Popular Science Monthly:*

I HAVE read, with much interest, the elaborate articles, by Judge Stallo, on "The Primary Concepts of Modern Physical Science," hoping, from the scholarly manner in which the author discusses the subject, that he would conduct us to some more acceptable conclusion than has hitherto been arrived at. I was disappointed, however, to find him surmounting the difficulties of the subject by assuming that the "typical and primary state of matter is a gas," which "is not a group of absolute solids, but is elastic to the core."

I do not propose to review nor criticize these learned articles of Judge Stallo, though there are various portions that I think quite vulnerable to criticism; but I must confess that the idea of an unparticled elastic body is to me an utter impossibility.

The subject presents very grave difficulties under any view of the case. For, if we assume the existence of an ultimate solid particle, universal *force* cannot be conserved, because the interference of solid particles must *destroy* motion, and therefore force. Hence, in that view of the case, we must have a continual destruction,

and therefore a continual creation of force. This conclusion I am not willing to accept, as I fully believe in the indestructibility of both matter and force.

The least objectionable view that I have been able to arrive at is, that all *ideas* are sensations excited primarily by material impressions, and hence that we can have absolutely no idea of space independent of matter.

And, as a stellar system in the universe of matter consists of millions of aggregated masses which are individually very small in proportion to the inter-spaces, so I believe that the chemical molecule is very small in proportion to the space between the molecules. And as each *sun* has (probably) various attendants (the planets), so each chemical molecule consists in general of several different bodies that may be easily separated (in consequence of the space between them being of the same *order* as the spaces between the molecules). But, like the different bodies of the solar system, or of a stellar system, each of these bodies is a compound mass consisting of millions of units of a different *order*, holding probably the same relation to the chemical molecule that the chemical molecule does to the matter of the solar system; and so on, both upward and downward, to infinity.

There is, therefore, as I conceive, absolutely no limit to the division of matter, physically as well as mathematically; but our organization is such that, of the infinite series of terms in which it manifests itself, we can know, experimentally, only two: viz., the stellar universe, constituting the first *order*, of which the stars and the planets are the units; and, secondly, the chemical molecule, which constitutes the second *order*.

According to this view, the material universe might be represented, in *orders*, by the following series:  $d^{-m}x, \dots d^{-2}x, d^{-2}x, d^{-1}x, d^0x, dx, d^2x, d^3x, \dots d^{n-1}x, d^n x$ , in which  $x$  is the unknown quantity, which we call matter, and  $m$  and  $n$  are both infinitely great.

In this series,  $d^0x$ , or simply  $x$ , would represent all tangible matter; and  $dx$ , which is the next term *descending*, would represent chemical molecules and their con-

stituents, the atoms of all known and unknown elementary bodies.

As in the analogous expression used in mathematical investigations,  $d^2x$  is infinitely small in respect to  $dx$ , which in its turn is infinitely small in respect to  $d^0x$ , and so on; yet each represents the elements of which the next preceding *order* is constituted. So in the physical world, as represented by the above series: the units in  $x$ , which are represented by the visible worlds in space, are infinitely large when compared with the units in  $dx$ , which are represented by the chemical molecules; the units in each preceding order, *in both series*, being aggregations of the units in the next succeeding *order*.

This view of the constitution of matter, though it necessitates the assumption of its actual infinite *division*, yet, to my mind, involves much less absurdity than to suppose it imparticled, and yet "elastic to the core," or to suppose that the chemical molecule, or even the chemical atom, is an absolute solid.

J. E. HENDRICKS.

DES MOINES, IOWA, November 21, 1873.

#### MATTER, FORCE, AND INERTIA.

To the Editor of the Popular Science Monthly:

JUDGE STALLO'S valuable contributions to the POPULAR SCIENCE MONTHLY, on the "Primary Concepts of Modern Science," can scarcely fail to give the reader a clearer conception of elementary being. But it seems to me that his criticism of Mr. Faraday's "complex forces," and Baine's assertion that "matter, force, and inertia, are substantially three names for the same fact," is clearly illogical.

On the ground that the existence of all reality lies in relation and contrast, the author assumes that inertia and force are ever coexisting contrasts. He says: "We know nothing of force except by its contrast with mass, or (what is the same thing) inertia; and, conversely, as I have already pointed out in my first article, we know nothing of mass, except by its relation to force. Mass, inertia (or, as it is sometimes though inaccurately called, matter *per se*) is indistinguishable from absolute nothingness; for matter reveals its presence, or evinces its reality, only in its action, its

force, its tension or motion. . . . It is impossible, therefore, to construct matter by a mere synthesis of forces."

Now, as all conceptions result from motion in the brain, it is self-evident that motion is the primordial reality whence all concepts arise, and that different conceptions of realities are solely different modes of motion, each distinct attribute being a distinct mode, and modified attributes are modified modes. Therefore a conception of matter, mass, inertia, or momentum, being solely a product of motion in the brain, and a conception of color being solely a product of motion in the brain, it is again self-evident that the only possible difference, between the primordial realities we call inertia and color, is difference in modes of motion.

Hence it is seen that the idea—almost

universal—that inertia, or momentum, necessarily coexists with motion, may have no foundation in fact; its error being further evidenced by our non-perception of their coexistence in the invisible, or molecular motions. In fact, inertia or momentum is only perceived in that single mode of motion which produces the sensation of touch; and which we designate as mechanical or mass-motion.

But whether or not momentum necessarily accompanies motion, it was shown above that the same reason for conceiving color to be solely a mode of motion equally obtains in our conception of matter, mass, or inertia, as a mode of motion; and that "all the reality we know" exists, primarily, in changing, but ever-existing, relations and contrasts of modes of motion.

A. ARNOLD.

## EDITOR'S TABLE.

### AGASSIZ.

OUR great naturalist has finished his work and passed away. His loss will be felt throughout the scientific world, and will be deeply lamented beyond the circles of science in all parts of our own country. Although he had accomplished much during a long and active life, he entertained no thought of rest, but was still full of hope, ambition, and large plans of labor, such as belong to the prime of manhood. But his physical powers at last gave way, and his career terminated, we might almost say prematurely, at the age of sixty-six. Of Prof. Agassiz's more strictly scientific labors we shall take an early opportunity to speak; we can here only briefly refer to some of the leading features of his career and character.

Prof. AGASSIZ was by descent a Frenchman, his family being among the Huguenots who were driven from France by the revocation of the Edict of Nantes, in the year 1685, and took refuge in Switzerland. He came of a

theological stock, being derived from six lineal generations of clergymen. He was born in 1807, the year that the first steamboat started on the Hudson, and when Humboldt, Cuvier, and Napoleon, were thirty-eight years of age.

It has been Prof. Agassiz's fortune to take a very conspicuous part in the scientific work of the present time. The Old World gave him his education, and the New World the best opportunity of using it. He was early and powerfully attracted to the study of Nature, while his mind was moulded and matured through intimate intercourse with the most illustrious men of science in Europe. He did his chief original work, and developed the views with which his name will be mainly associated, in his youth and middle life, and at the age of thirty-nine he left the continent, where scientific men abounded, and took up his residence in a new country where they were wanted, and where the opportunities, both of entering unexplored fields of investigation and of drawing men and institutions

into the work, were alike unparalleled; while the course he pursued has turned out as wise for his own fame as it has proved favorable to the interests of advancing knowledge.

It is well known that Prof. Agassiz was a man of strong personality. He had great enthusiasm and impulsiveness, and the whole fervor and intensity of his nature was spent in the single-minded pursuit of science. Not content with what he could himself know, and do, and enjoy, he was powerfully impelled to make others the sharers of his knowledge, his activity, and his pleasures. He not only won them to him by his geniality, and his cordial and unaffected manners, but he inspired them with his own purposes, and moved them to his own ends. Sympathetic with all who were interested in science, he especially fascinated young men, and the ranks of our naturalists are full of those who were recruited to the work by his agency, among whom may be mentioned Verrill, Stimson, Clark, Hyatt, Putnam, Packard, Scudder, Hartt, Tenney, Morse, Niles, and Bickmore. One of his students writes of him as follows:

"Agassiz's enthusiasm did not consist merely in scientific investigation and in earnest words, but also in earnest deeds in relation to others, and especially in relation to young men. Wherever he saw a student who would study Nature, he opened the way for him, took him into his laboratory, spread his treasures before him and directed his studies, and this too without any expectation or thought of a pecuniary reward as a return. Indeed, I do not know of a single student who ever paid him a dollar as tuition for his instruction in natural history studies. Young men came and staid and studied as long as they would, and, as far as tuition was concerned, without money and without price. To the present writer he said, twenty years ago: 'Whenever you get ready to study natural history, come to Cambridge, and remember it will not cost you a cent of money.'"

But Prof. Agassiz's influence was far from being confined to a small class

of congenial students; it was very powerful upon the general public. A republican by nativity, and a republican by adoption, he was also a republican in sympathy and in principle, by association and habit. Although coming to this country as a great man from Europe, he had no factitious dignity to sustain, and no scruples to overcome, in plunging at once into the work of popular teaching. Entering early and fully into the spirit of our institutions, he went among the people at large, gave courses of lectures upon zoology in all the chief towns of the country, and was indefatigable in the diffusion of knowledge, and in awakening a higher appreciation of science among the people. In this he was wise and sagacious to the specific ends he had in view, for he well understood that in this country the prosperity of science is ultimately bound up with its public appreciation. In this field of effort too he was preëminently successful. As Mr. Beecher remarks, in the *Christian Union*:

"Agassiz stepped upon the lecture platform in Boston, and day after day fascinated a great audience with the fairy tales of science and the long result of time. That appreciation might have been predicted of Boston culture, perhaps. But when the master took his black-board and his problems to the smaller cities, drawing his queer diagrams, and unfolding their vast meaning before lyceum associations, normal schools, colleges, high-schools, those benches, too, were crowded with eager and intelligent listeners. It was Agassiz who made straight the path of Tyndall last winter, created the demand for Huxley's lectures, and made THE POPULAR SCIENCE MONTHLY as much a necessity as *Harper* or the *Atlantic*. It was Agassiz whose large intent laid the cornerstone of our institutes of technology, and scientific schools in colleges."

But no estimate of Prof. Agassiz's real work among the American people will be just that stops here. True, he gave his best powers to the instruction of teachers, farmers, mechanics, and artisans, but it was not merely as a



scatterer of his own stores of knowledge. He had a profound interest in popular education, but the soul of that interest was for improvement in its methods. In the matter of public instruction he was a revolutionist and a propagandist. He warred with current ideas and consecrated practices. He condemned in the most emphatic way the wretched lesson-learning routine that prevails in the schools. He denounced our wordy and bookish education as baseless and unreal, and demanded such a change in our systems of instruction as shall bring the pupils face to face with Nature herself, and call out the mind by direct exercise upon phenomena—the facts, laws, relations, and realities of the world of experience. He was at times inclined to take discouraging views of the educational future, from this enslavement of the schools to vicious methods of study, but he never wearied in the endeavor to propagate more rational opinions, and we cannot doubt that the seed thus sown will yet ripen into most valuable fruit. It is questionable, indeed, if his earnest exertions in this direction will not tell in the final promotion of science even more powerfully than all his attempts to attain immediate results.

Another feature of Prof. Agassiz's scientific character remains to be noticed. Science was to him not merely the knowledge of animals, rocks, and glaciers, but it was a method of thought, rising into the proportions of a philosophy, and embracing the interests of humanity. By the vulgar-minded he was looked upon as a very wonderful man, whose genius spent itself upon crabs and their kindred, and who would give the world for a new fish. This was regarded as an amiable and an admirable eccentricity, and everybody was pleased when he had got a new donation to buy more curious things for his museum. And it was freely said, "If men of science would only imitate Agassiz, and be content with their dis-

sections and collections, and keep in their sphere, and not encroach upon departments of thought which belong to politicians, theologians, historians, and philanthropists, the world might get on in peace." But this is a very mistaken conception of Agassiz's views of science. He saw in it not only a disclosure of the laws of physical nature, and an interpretation of the principles of life, but a revelation of correlated truths of all orders indispensable to the progress of man. This he ever maintained, and this he affirmed in the last essay perhaps that he ever wrote, and which was published in the *Atlantic Monthly* but a few days after his death. In that article there occurs the following passage, which our readers will attest might have been a fit motto for THE POPULAR SCIENCE MONTHLY:

"It cannot be too soon understood that science is one, and that whether we investigate philosophy, theology, history, or physics, we are dealing with the same problem, culminating in the knowledge of ourselves. Speech is known only in connection with the organs of man, thought in connection with his brain, religion as the expression of his aspirations, history as the record of his deeds, and physical sciences as the laws under which he lives. Philosophers and theologians have yet to learn that a physical fact is as sacred as a moral principle. Our own nature demands from us this double allegiance."

WE had intended to say nothing at the present time about Agassiz and Evolution, thinking it most suitable to forget all differences in the heart-felt acknowledgment of what we owe to his noble and disinterested life. But the occasion of his death has been so widely used in the interest of prejudice and error that a few words upon this subject become unavoidable.

Prof. Agassiz was an opponent of Darwinism, but his opposition gave no excuse for the amount of stupid rant upon the question which has been late-

ly poured forth. The following passage from an elaborate article on Prof. Agassiz, in one of our leading morning papers, is a fair example of a good deal of the talk that has been latterly indulged in by the press: "His views of the development of animal species, opposed entirely to the gloomy theory of Darwin, which has fallen so oppressively upon the world, while they neglect no fact and break no link in the chain of progress, are marked by a recognition of a distinct humanity and a high creative purpose in the Divine origin of all things which elevate and cheer and relieve us of the sickening consciousness that man, 'the paragon of animals,' is merely a growth from some shapeless, loathsome jelly."

We have here a moral estimate of "jelly," and a vehement denial of its fitness to be the material from which the "paragon of animals" originates; the bare idea being declared sufficient to shroud the universe in gloom, and fairly to make one sick. But perplexing questions here arise. *Omnes vivum ex ovo*, and the substance of all eggs is jelly; but, if this substance was not fit to use at the primal start of life, why is it so extensively employed now? If not fit for the elaboration of the lowest creatures, how came it to be employed in unfolding the "paragon?" and, if not always used, pray when and why was it introduced? One would think, from the writer's horror of "jelly," that he regarded it as a diabolical invention of Darwin; threatening a kind of gelatinous "fall of man," from which Prof. Agassiz has had the happiness of rescuing the world, and restoring it to cheerfulness. But really Mr. Darwin is responsible for neither the existence nor the office nor the extent of "jelly" in Nature; and of all men Prof. Agassiz is the last to lead a crusade against it. As an eminent embryologist, he might properly be called the high-priest of "jelly." He was never weary of explaining that all liv-

ing things—each man, as well as every inferior animal—is actually evolved from a little mass of "jelly;" and, while he would probably have agreed as to its shapelessness, he would certainly have protested against its "loathsomeness." He who said that "our philosophers and theologians" (and, he might have added, our editors) require to be taught that "a physical fact is as sacred as a moral principle," would hardly have sickened over the "loathsomeness" of that plastic material which we know to be the starting-point of all organic development.

Agassiz held that Nature is to be regarded as the material embodiment of divine ideas, and, after dwelling with delight upon the curious forms and constitutions of creatures composed almost wholly of "jelly," he would say, "These are the thoughts of the Almighty." On his view, "jelly" was the chosen and specially honored material for the expression of the divine conceptions. Prof. Agassiz would certainly have considered the little protoplasmic speck, which, in the course of natural operations, can evolve in a few years into a Newton, a Shakespeare, or even a President of the United States, as an exceedingly interesting portion of the divine order. If the germ contains potentially the future being, and if a highly-developed race transmits its aptitudes and capacities from generation to generation, then is "jelly" an institution of God for the conservation of perfected man, and the civilization that he carries with him.

With such evidences as this of the prevailing state of mind, no wonder that the great naturalist was vehement almost to fanaticism in his advocacy of scientific education. In old prescientific times, Nature was held accursed; and that such stuff as we have here quoted could find entrance into a widely-circulated organ of public opinion, is proof to how great an extent we are still dominated by middle-age ideas.

Since his death, Prof. Agassiz has been much and ardently lauded as a Christian scientist, and a champion of the faith against scientific skepticism. It is gratifying to be assured that he was neither a Mohammedan, nor a Buddhist, nor a Sun-worshiper, but a good Christian, as he ought to have been; and here, perhaps, it would be as well to let the matter rest. But, when we are told that Agassiz was a Christian *because of his opposition to Darwinism*, we decidedly object. Prof. Agassiz was a Theist, who ascribed the universe to a Divine Mind; Darwinians do the same. That Prof. Agassiz has attempted to show the incompatibility of the Christian system of doctrine with Darwinian ideas, we are not aware; but, on the other hand, there are many Christian theologians who take the opposite view. As we show in another place, a literature of reconciliation is springing up, and we are beginning to hear of Christian evolutionists, as we have long heard of Christian astronomers and Christian geologists. But because Agassiz was a Theist, it by no means follows that his theories of Natural History were specially religious, and the attempt to make them so, so far as influential at all, will be doubly mischievous. It will prejudice scientific inquiry by favoring the idea that the results of investigation may be irreligious; and it will injure Christianity by identifying it with physical doctrines and interpretations of Nature, which it is the business of science to investigate, and which investigation is liable to change. He who insists upon linking religion to any view of natural phenomena, puts it in grave peril. The attempt, long ago made, to identify it with the belief in the flatness and fixity of the earth was a serious error; and the subsequent attempt to identify it with the doctrine of the recent creation of the earth was another mischievous mistake. To try the experiment a

third time, in the domain of Biology, cannot fail to be still more injurious. It is believed by great numbers of the most intelligent students of the subject that the old opinions regarding the origin of living things upon earth are certainly doomed to pass away. At all events, the subject is unsettled, and it is therefore unwise to make Christianity a partisan to any of its theories.

It is well also to bear in mind that, if Agassiz fights Darwinism, he accepts Evolution. Forty years ago he wrote of the life upon the globe, "An invisible thread in all ages runs through its immense diversity, exhibiting as a general result the fact that there is a constant progress and development ending in man;" and, in his very last article, to the question, "Is there any such process as evolution in Nature?" he answers, "Unquestionably, yes." He was of opinion that little as yet has been contributed toward the scientific solution of this great problem; but, however that may be, evolution in Nature he conceded as a fact which belongs to the future of science. If, therefore, Agassiz was a Christian, belief in evolution is not inconsistent with Christianity. This is the ground now taken by many eminent theologians, who, like Dr. McCosh, maintain that Christianity has no interest in holding by the question one way or the other. Dr. Peabody, in his sermon at the funeral of Agassiz, took a similar position, and is reported to have said: "His repugnance to Darwinism grew in great part from his apprehension of its atheistical tendency, an apprehension which, I confess, I cannot share; for I forget not that these theories, now on the ascendant, are maintained by not a few devout Christian men, and while they seem to me unproved and incapable of démonstration, I could admit them without parting with one iota of my faith in God and Christ."

## LITERARY NOTICES.

## INTERNATIONAL SCIENTIFIC SERIES.

**THE NEW CHEMISTRY.** By J. P. COOKE, Professor of Chemistry in Harvard University. 326 pages. D. Appleton & Co. Price, \$2.00.

It is well known that chemical science has been recently undergoing a great change in its theory of the constitution of bodies. The Lavoisierian chemistry, or the dual chemistry, by which all compounds were supposed to be simply paired, as metal with metalloid, acid with base, may be fairly said to have passed away. New ideas have been introduced which were but partially and reluctantly received at first, and were indeed sharply resisted by the masters of the old method, but which have at length forced their way and grown into a definite system. With the breaking up of the old method the old nomenclature has been shattered, and a new nomenclature has taken its place. In chemistry, therefore, the present is a time of transition and discomfort. What was long settled, and upon which we reposed in the confidence that it would never be disturbed, has proved an insecure result of imperfect knowledge, but which has served the important office of bringing us up to higher and more perfect views. There is a sadness in parting with old familiar ideas, as with old friends, but changes must come. In chemistry, the facts had outgrown the theories that expressed them. New facts were discovered for which the old system could find no place, and these accumulated until at length a new method of interpretation was attained, by which chemical philosophy has been placed upon a broader and it is hoped a more enduring basis. But, whatever may be its permanence, it is now fairly established, and so marked is its contrast with past theories, and so distinct are its features, that it has become fully recognized as "The New Chemistry."

The new chemistry has been fully adopted by various authors in their text-books, and partially adopted by others; but only with subdued satisfaction, as in the first cases students have been frightened by the formidable array of strange terms, definitions, and ideas, and in the latter case they

have been confused by the intermixture of different systems. The great need, therefore, was for a new and compendious work that should be simply devoted to an explanation of the new system. Prof. Cooke, of Cambridge, has undertaken this task in the book before us, and most successfully and admirably has he accomplished it. He had already published a large collegiate text-book of "Chemical Philosophy," on the new method, which he has taught for years to the classes of Harvard University. But the demand was so urgent for a separate volume, that should present in a clear and popular manner the new aspects in which chemical facts and principles are now regarded, that he was induced to undertake it, in the interest of general education. He prepared his views first as a course of lectures, which were delivered at the Lowell Institute, in Boston. It was there shown that "The New Chemistry" may be made attractive to a general audience, as these lectures excited much interest, and were listened to with earnest attention throughout. After being thus tested, they were thoroughly revised by their author, and are now published, with illustrations, in a neat and convenient form. No book in the whole range of science was so greatly needed as this, and it is fortunate for the public that the want was supplied by such an able hand. Not only the chemical student, but all who are interested in this fascinating science, and all who are concerned with the advancement of scientific ideas, will find that this volume bridges over the gap between the old and the new, and will prove a most valuable introduction to the larger treatises which represent the present state of the science.

This is the first American volume contributed to the International Scientific Series, and, as it is unquestionably the best book in any language upon the subject, it will be sure to increase the already high reputation of these publications.

**THE INTERNATIONAL REVIEW.** Six Times a Year. January, 1874. 144 pages. Price, \$5.00 a Year. A. S. Barnes & Co.

THE first number of this periodical contains six articles, as follows: I. Our Late Panic. II. Fires in American Cities, by

Prof. A. P. PEABODY, D. D., Cambridge, Mass. III. Deep-Sea Exploration, by Prof. WM. B. CARPENTER, M. D., LL. D., F. R. S., London. IV. Universal Education, by RAY PALMER, D. D., New York. V. The Prussian Church Law, by Baron FRANZ VON HOLTZENDORFF, LL. D., Munich. VI. International Arbitration, by THEODORE D. WOOLSEY, D. D., LL. D., New Haven.

It is always unfair to judge a periodical enterprise like this by its first number; for, although, in the present case, there has been long preparation, nothing can compensate for want of experience and the advantages of public criticism. The present number contains much good reading, although it is rather the opposite of lively. Half its articles are by D. D.'s, which gives promise that it is to be safely and conservatively conducted. This is important, as we must have ratchet-gear to hold what the driving impulses of advancing thought have gained. Yet it is very easy to pass from conservation to obstruction; and the somewhat spiteful kick given to Prof. Bain for his little book on "Mind and Body," while it seems to indicate the whereabouts of the *International*, suggests also that its editor may be in danger of overlooking the above distinction. The position taken being important as a symptom of the future course of the *Review*, it is worthy of some remark.

The school of mental philosophy, of which Bain is a leading representative, differs from the old metaphysical school in considering mind and body together, in their connections, interactions, and dependencies; and in maintaining that there can be no true mental *philosophy* without taking both factors into account. The old metaphysicians attended to the one and neglected the other; and what was worse, they magnified the one and decried the other, drawing perpetual contrasts between spiritual mind and "mere brute matter." An undoubted and very important step forward has been made in the scientific study of both orders of phenomena, as we find them related in Nature and in fact. Modern psychology, indeed, differs from the old metaphysics simply in conquering its prejudices, in taking into account all the elements of the problem, and treating them by the sci-

entific method. Very naturally, the special work to be done has been to bring forward and assign its proper place to the neglected element, matter; whereupon the partisans of the old view make an endless ado about the encroachments of Materialism. When Prof. Bain refers to the structure of the brain, in the albuminous tissues and corpuscles of which all our natural and acquired aptitudes are stored up, the writer in the *International* is offended at such a "gross form of expression," and sighs for the good old times of Reid and Stewart, who "seem like intellectual giants when compared with the Professor of Aberdeen."

The writer observes that "nothing is more certain than our ability to separate mental and physical phenomena," and he might have added that bullets, strychnine, and lightning, are the most effectual means of doing it. But, when the separation is effected, mental phenomena disappear, and there is, therefore, an end to the study of mind. Of mental phenomena dissociated from physical phenomena we know absolutely nothing. If the writer means that "nothing is more certain than our ability to separate mental and physical phenomena" for the purpose of inquiring into their nature and laws, then we say that nothing is more false than the statement. We know nothing of mind, except as limited and conditioned by association with matter. The mode of union is a mystery, but the fact of union and of unity is undeniable. The very essence of the mystery is the oneness of that which exhibits such widely-different effects. The animate organism manifests at the same time psychical and material properties. We may confine our attention to either, or to parts of either, but we cannot separate them. Theory after theory has been offered for thousands of years to explain the relation. Science takes things as it finds them, and occupies itself in tracing the relations and dependencies among the phenomenal effects. This is Prof. Bain's method, and he has made it his great task to bring forward the long-neglected corporeal side of the inquiry, and to include the body in the study of the mind. Metaphysics does not require this, but science does require it, and the later

psychology recognizes it. It is futile to talk of going back to Reid and Stewart, or to look for the coming genius who is to restore them; their period is gone by.

**RELIGION AND SCIENCE.** A Series of Sunday Lectures, on the Relation of Natural and Revealed Religion; or, the Truths revealed in Nature and Scripture. By JOSEPH LE CONTE, Professor of Geology and Natural History in the University of California. 324 pages. D. Appleton & Co.

THE rapid multiplication of works at the present time which aim to bring the views of modern science into harmony with religious doctrines, is at once an attestation of the increasing interest generally taken in scientific subjects, and of the growth of a catholic and more tolerant spirit in regard to scientific and theological diversities of opinion resulting in more earnest efforts to harmonize them. The necessity for such reconciliations has arisen from time to time from the fact that theology has lent its sanction to given interpretations of natural things, while it has been the general work of science to revise and often to set aside such interpretations in the course of its progress. The main difficulty in this work of reconciliation has been the want of minds great enough to grasp and to master both spheres of inquiry. The efforts at harmonization have generally come from partisans of opposing views, who aimed at agreement by demanding great concessions from the opposite side. The scientists often ask theologians to renounce the main pretensions of theology for the sake of peace, and the theologians request the scientists to eschew three-fourths of what they believe as mere pseudo-science, that concord of opinion may be reached. And so they have alternated between treating and fighting, until at last a peace is conquered. Mean time, as the battle subsides in one field, it breaks out in another. In the field of Astronomy, where once the conflict raged with the greatest fury, all is now serene, and the Geological struggle has also become a memory. In the field of Evolution, there is still a kind of warfare, much din and smoke, and some bruises, if little slaughter. But the conflict is now undoubtedly more mild and restrained, as it will probably be

more brief. In reviewing the past epochs of the conflict, it would be unwise to forget that both parties to the strife have often cared more for the combat than the cause, and, as in street-brawls, have often turned upon the peace-maker, for human nature is pugnacious, and dislikes to be interrupted in a good fight. But it is one of the grand offices of science to substitute truth for victory in the mental conflicts of men, and therefore to reduce the virulence of polemics. This is one of the ways in which science exerts a liberalizing influence, and, as the acerbities of controversy abate, and the passions are less enlisted, the harsher points of disagreement may be expected gradually to drop away.

Prof. Le Conte's admirable little book is born of the best spirit of conciliation, and goes over the whole ground of conflict, in its latest aspects, between Religion and Science. In his preface he says: "The series of lectures contained in this little volume is the result of an earnest attempt to reconcile the truths revealed in Scripture with those revealed in Nature, by one who has, all his active life, been a reverent student of both;" and he adds: "I may not entirely please either the mere scientist on the one hand, or the mere theologian on the other, but I have no apology to make for this. Perhaps my views may be all the more rational on that very account."

Prof. Le Conte's book has the rare advantage of having been produced by a man not only of profoundly earnest convictions, but of thorough intellectual preparation. His high position in the world of science has been long assured through his original contributions to some of its highest questions. He was one of the pioneer expositors of the doctrine of the correlation of forces in its application to life and its organization, and shows a wide and clear understanding of the various bearings of recent scientific inquiry. On the other hand, he holds to the great fundamental tenets of orthodox Christianity, and is therefore thoroughly prepared to consider the mutual relations of these systems of thought. Holding that all truth is one, and ever consistent with itself, he points out the past grounds of misapprehension, and shows how they may be removed, and reconciliation attained.



Of the success of his attempt there will be various estimates, but there can be but one opinion upon the point that he has greatly enriched the discussion by new and ingenious arguments for the removal of past antagonisms. We may add that, on its scientific side, the book abounds in clear and instructive statements of facts and laws that are now established, while the accompanying philosophical discussion brings them out in clearer light and more impressive aspects.

**THE THEORY OF EVOLUTION OF LIVING THINGS, AND THE APPLICATION OF THE PRINCIPLES OF EVOLUTION TO RELIGION.** Considered as Illustrative of the "Wisdom and Beneficence of the Almighty." By the Rev. GEORGE HENSLOW, F. L. S. Macmillan & Co.

WE noticed, last November, a book called the "Philosophy of Evolution," by B. Thompson Lowne, which we explained to be an Actonian Prize Essay. It was stated that Hannah Acton had left a lot of money to the Royal Institution, the income of which was to be spent as prizes for scientific essays, illustrating the wisdom and goodness of God. We stated that seven years ago the Solar Radiations were proposed for a prize, but that, no volume appearing to claim it, the money was left to accumulate, so that this year there were two prizes. But we were mistaken: the Solar Radiation man furnished his essay, and got his money. Nevertheless, such has been the good management of Widow Acton's funds, that there were two prizes this year; Lowne got one, and Henslow the other, for the book now before us. It is a volume of most excellent intentions, and not without some merit. It is, however, mainly significant from the evidence it affords that theologians are beginning to regard the situation calmly, and to adjust themselves to the new circumstances. Professor Henslow is not only a clergyman, but a man of science, a cultivated botanist, and son of the late eminent Professor of Botany in Cambridge. His opinions will, therefore, be entitled to weight from those of his own class. We published an interesting chapter from his book last month, under the title of "Genesis, Geology, and Evolution."

**THE BIBLE AND THE DOCTRINE OF EVOLUTION.** Being a Complete Synthesis of their Truth, and giving a sure Scientific Basis for the Doctrine of Scripture. By WILLIAM WOODS SMYTHE. 390 pages. London: H. K. Lewis.

WE have here another volume of the same scope as Prof. Henslow's, but a far abler book. The author's argument is close and searching, and the case he makes out is very strong. The point of view from which it is written is illustrated by the following passage from the Dean of Canterbury: "Possibly to our views of the nature of Christianity, and in our exegesis of Scripture, we have arrived only at partial truth; and do not distinguish with sufficient accuracy between what is certainly revealed and what is nothing more than a possible explanation of the divine word." The book exemplifies not only a thorough acquaintance with the doctrine of Evolution, and the extent and grounds of its proofs, but it exemplifies an equal mastery of biblical erudition. Nor is it offered as a mere ingenious attempt to ascertain the points of correspondence between Scripture statement and recent scientific speculations. The author is a profound believer in the principle of Evolution, which he maintains to be the fundamental law alike of Nature and Christianity, and he holds that "the plain and obvious interpretation of Scripture is the most congruous with the principles of Evolution." He recognizes his work as but the opening outline of an inquiry which must be carefully filled up, "the intention being to place stepping-stones, however unhewn, across a troublesome and heretofore impassable stream, which in the future may grow into a highway that the fool cannot err therein." The author acknowledges indebtedness for assistance and advice to a large number of clergymen whom he has consulted in the preparation of his work.

It is gratifying to observe that the author, who has thus far gone most thoroughly into the investigation he undertakes, shows also the most intelligent appreciation of the minds that have contributed to the working out of the great doctrine with which he is dealing. He says: "It does not seem to be sufficiently understood that Evolution owes much more to Mr. Spencer than to Mr. Darwin. The latter only de-

veloped part of the doctrine; never perceived its relation to the whole, nor its purely scientific interpretation. The works of the former are, therefore, most referred to here."

"The doctrine of Evolution, as developed by Mr. Herbert Spencer, is not an empty hypothesis excogitated as a plausible account of the phenomena of the universe, but a great philosophic system, founded solidly on carefully-corrected experience of the things and forces of the universe. And it becomes a subject of the deepest interest to compare the *priori* theory of the universe, contained in Scripture, with the *posteriori* doctrine formulated from the facts of our uniform experience."

We cordially recommend this volume to all who are interested in that aspect of the question to which it is devoted.

DESCRIPTIVE SOCIOLOGY. Part I. THE SOCIOLOGICAL HISTORY OF ENGLAND. By HERBERT SPENCER, assisted by James Collier. Price, \$5. D. Appleton & Co.

It has been repeatedly explained in the columns of the MONTHLY that Herbert Spencer has been engaged for some years in the formidable undertaking of collecting and classifying the data required of the scientific study of human society. For this purpose he divided the races of mankind into three great groups, or divisions: I. The Savage Races; II. The Extinct, or Decayed Civilizations; and III. The Existing Civilized Races. The part now published belongs to the third division, and in it Mr. Spencer applies his method to the Social History of England. If it be asked why he did not begin with Division I., presenting the simpler phenomena of uncultivated societies first, the reply is, that, while the publication of the whole series is by no means certain, and will be contingent upon the reception of the earlier parts, it was desirable to begin with a branch of the subject on which there cannot fail to be the most general interest, while it, moreover, subjects Mr. Spencer's method to the severest test. Besides, it is quite immaterial at what point the exposition is commenced, as it is perfectly simple and complete in each case.

The present work is free from all hy-

pothesis and speculative views. Only the facts are given, and the authorities for the facts. Mr. Spencer expresses no opinion, and draws no inferences; he only classifies his materials in such a way that at one view we can take in all the great social facts of any epoch, and compare them with the phenomena that precede them, and out of which they grew, and those which follow them, and to which they give rise. In the "Principles of Sociology," upon which Mr. Spencer has now entered, he will work out the inductions and generalizations from this vast body of social facts in his own way; but, meantime, they have an independent value for all students who choose to draw their own conclusions.

The work is in a folio form, which was made necessary by the structure of the tables, the very first condition of which is, to bring into convenient comparison many series of facts. For all his statements made in the tables the authorities are given in a corresponding classification, the text consisting of quotations and extracts, which constitute the chief portion of the work. The material here published would form a large octavo volume of eight or nine hundred pages.

We consider this work one of very great public importance, as it is undoubtedly a large step forward in the direction of that knowledge which is more needed than any other. The question, What are the natural laws by which human societies have originated, been developed to their present state, and must still further advance?—the laws, therefore, by which their destiny is governed—is supreme at the present time. Our ideas upon the subject have hitherto been chaotic, and, for want of any fixed principle, the social field has been given over to quacks, dreamers, and swindlers of every quality. If science has any light to shed upon this matter that can help in the practical guidance of affairs, the world is in deplorable want of it. The work before us is only preliminary, but we think no candid mind can examine it without being convinced that it opens a new dispensation of social study, and paves the way to a more scientific consideration of social phenomena than we have ever before had. If in this it may be thought that we are writing under

a "bias," let us see what others say about it. The *British Quarterly Review* observes: "No words are needed to indicate the immense labor here bestowed, or the great sociological benefit which such a mass of tabulated matter, done under such competent direction, will confer. The work will constitute an epoch in the science of comparative sociology."

The able London correspondent of the *Tribune* says of the work: "The arrangement of the whole is so clear that the least scientific student in search of a fact will have no difficulty in putting his finger on what he wants. . . . The work is a gigantic one; its value, when complete, will be immeasurable; and its actual influence on the study of sociology, and help to that study, greater perhaps than any book yet published. It is a cyclopædia of Social Science, but a cyclopædia edited by the greatest of sociologists."

Mr. E. B. Tylor, author of "Primitive Culture," and one of the highest English authorities upon the study of the early development of society, writes, in *Nature* of October 30th: "So much information encumbered with so little rubbish, has never before been brought to bear on the development of English institutions. There is hardly a living student but will gain something by looking through the compilation which relates to his own special subject, whether this be law or morals, education or theology, the division of labor, or the rise of modern scientific ideas."

We can give no better general account of Spencer's work than to quote more fully from this review of it by Mr. Tylor:

"This first section is a methodical summary of the development of England, intellectual and moral, from the beginning of its history in Cæsar's time, to about A. D. 1850. At the first glance, it suggests a question which may disconcert not a few of the lecturers and tutors engaged in training students in history at our universities. This question is, whether the ethnological record of national life ought any longer to be treated as subordinate to the political record of the succession of rulers and the struggles for supremacy of ruling families, or whether the condition of society at its successive periods is for the future to be considered as the

main subject, only marked out chronologically by reigns, battles, and treaties. This question has, it is true, been already raised. It is, in fact, the issue between historical chronicle and the philosophy of history as rival subjects of study. But Mr. Spencer's work brings it more clearly and practically into view than any previous one, as will be seen from the following outline of his scheme. It consists of two parts.

"The first part is a series of tables, arranged in thirty to thirty-five columns, each with a heading of some department of social life or history, which again are combined into groups. Thus the group of columns relating to the structure of society takes in political, ecclesiastical, and ceremonial departments, under which again we find separately given the laws of marriage and inheritance, the regulation of tribes and castes, the military and ecclesiastical organization, and the ceremonies and customs of daily life. Next, the group of columns devoted to the functions of society, regulative and operative, contains particulars of the morals, religion, and knowledge of each age, the state of language, and the details of industry, commerce, habitations, food, clothing, and artistic products. Three special columns at the beginning, middle, and end of this long colonnade, contain the skeleton of ordinary history: namely, the principal dates, names of rulers, and political events. Thus, by glancing across any one of the huge double pages, we see the whole condition of England at any selected period. Thus, in the century after the Norman Conquest, the influence of the invaders is observed in the growth of architecture, painting, music, poetry, the introduction of new food and more luxurious living, the importation of canonical law and of mathematics from the East, and so on through all the manifold elements which made up the life of noble and villain in our land. If the page be turned to the sixteenth century, the picture of English life is not less distinct. The scholastic philosophy is dying out, men's minds are newly set to work by the classical revival, by voyages into new regions, the growth of mercantile adventure and political speculation; chivalry ceases, archery declines; judicial torture is introduced, the 'Italian' crime of poisoning becomes fre-

quent; the ancient belief in witchcraft and pervading demons holds its ground, as do the miracle-plays and local festivals; but a highway act is passed, new roads are being made, the new houses have chimneys, their furniture and fare become more luxurious; the power of the old feudal families is destroyed, the Star-Chamber is new-modeled; church-fasts are still observed under pain of imprisonment, and high offices of state are still in the hands of churchmen, but among the signs of momentous change come the dissolution of monasteries, and the distinct appearance of a sect of Protestants. Thus the tabulated record goes on till it ends near the present day, among such items as Trades-Unions, Divorce Courts, the Manchester School, County Courts, Free Thought, Railways, Rifled Cannon, Pre-Raphaeltism, Chartism, Papal Aggression, and the crowding events of modern manufacture and science.

"It is by following the several columns downward, that the principle of Evolution, the real key to Mr. Spencer's scheme, is brought out into the broadest light. It seems most strange, however, that he should not have placed in its proper niche the evidence of prehistoric archæology. Mr. Spencer can hardly doubt that the stone implements found in England prove the existence of one, or probably two, stone-age populations before the Celts, who, under the name of Ancient Britons, begin his series. If he acknowledges this, why should a first link so important in his chain of evolution have been dropped? Otherwise the chain is carefully stretched out so as to display it from end to end. In many matters, simple and direct progress is the rule. From the ancient Briton's bow with its bronze-tipped arrows, to the cross-bow, the matchlock-gun, and thence through successive stages to the rifled breech-loader; from the rude arithmetic before the introduction of the 'Arabic' numerals, through the long series of importations and discoveries which led to the infinitesimal calculus in its highest modern development; from the early English astronomy, where there was still a solid firmament studded with stars, and revolving on the poles about the central earth, to the period when the perturbations of planets are calculated on the theory of gravitation, and the

constitution of the fixed stars examined by the spectroscope—these are among the multitude of cases illustrating the development of culture in its straightforward course. Harder problems come before us, where we see some institution arise, flourish, and decline within a limited period, as though resulting from a temporary combination of social forces, or answering only a temporary purpose in civilization.

"To take an instance from Mr. Spencer's table, English history has seen the judicial duel brought in at the Conquest, flourishing for centuries, declining for centuries more, till its last formal relic was abolished in 1820. Again, in the Old English period, marriage appears as a purely civil contract, on the basis of purchase of the wife; then with Christianity comes in the religious sanction, which by 1076 had become so absolute that secular marriages were prohibited: with a strong turn of the tide of public opinion, the English Marriage Act of 1653 treated marriage as a civil contract, to be solemnized before a justice of the peace; till, after a series of actions and reactions, in our own day the civil and ecclesiastical solemnization stand on an equal footing before the law. Closely similar has been the course of English society on the larger question of a National Church, which, soon after the introduction of Christianity, claimed an all but absolute conformity throughout the nation, practically maintained the claim for ages, and then was forced back to toleration, which has at last left it with a supremacy little more than nominal. This is not the place to discuss these subjects for themselves, but to show how the table before us; by its mere statement of classified events in chronological order, must force even the unwilling student to recognize processes of evolution in every department of social life. The writer of the present notice once asked an eminent English historian, a scholar to whom the records of mediæval politics are as familiar as our daily newspaper is to us, whether he believed in the existence of what is called the philosophy of history. The historian avowed his profound distrust of, and almost disbelief in, any such philosophy. Now, it may seem a simple matter to have tabulated the main phenomena of English social and political

history in parallel columns, as Mr. Collier has here done under Mr. Spencer's direction, but his tables are a sufficient answer to all disbelievers in the possibility of a science of history. Where the chronicle of individual lives often perplexes and mystifies the scholar, the generalization of social principles from the chronicler's materials shows an order of human affairs where cause and effect take their inevitable course, as in *Physics* or *Biology*."

## MISCELLANY.

**New Material for Dental Plates.**—Among the novelties exhibited at the American Institute Fair is a new base for artificial teeth, the invention of a New York dentist. It consists mainly of fish-scales, which, dissolved and combined with certain fibrous and adhesive substances, form a compound that is said to be well adapted for use as dental plates. Greater strength, durability, and lightness, and freedom from all taste, are the advantages claimed for it over the materials in common use. It is capable of receiving a fine polish, and may also be readily colored to any desired tint, qualities which adapt it to a great variety of purposes outside of dentistry. It is also said to be an excellent material for waterproofing cloth.

**Meteorological.**—In his report for 1872, Mr. Daniel Draper, Director of the Meteorological Observatory in Central Park, considers the following points :

1. "Has the summer temperature of the Atlantic States undergone any modifications?"
2. "What is the direction in which atmospheric fluctuations cross the United States?"
3. "Is it possible to trace the passage of American storms across the Atlantic, and predict the time of their arrival on the European coast?"

By carefully-arranged tables, he shows that no change has taken place in summer temperature, and concludes that "the mean heat of summer and the mean cold of winter are the same now as they were more than a century ago."

These conclusions are from observations made in Boston, New Haven, New York,

Philadelphia, and Charleston. It may be added that, in his former reports, it was shown that over the same areas the annual rainfall has neither increased nor diminished.

The movement of atmospheric fluctuations is illustrated by diagrams founded on observations at the Observatory, and the daily maps published at Washington. It appears that these movements are not all cyclonic—many are like waves of the ocean, long and straight, and have a forward motion. This motion over the United States is eastward. The velocity of this motion has been determined in a great number of instances for the years 1869, 1870, 1871, and 1872. During the last year the highest forward velocity was 569 miles in twenty-four hours; the lowest velocity, 82 miles in twenty-four hours. The highest velocity recorded was about 29 miles an hour, or 690 miles in twenty-four hours; this occurred on the 28th of March, 1870. The time required to cross the Atlantic varied from ten to twenty days. It sometimes happens that storms which leave our coast three and four days apart arrive on the coast of Europe together, and, in such cases, the storm is usually severe. The observations made show that, out of eighty-six storms expected to cross the Atlantic, only three seem to have failed. Moreover, it is shown that the direction of the movement is maintained, so that it may be known several days in advance what part of the coast of Europe will be covered by the advancing storm.

The great practical value of these observations and reports will be at once recognized, and the conclusions they suggest and confirm are among the most interesting of the results of modern scientific research.

**Sewage Fertilization.**—The following, from the report of the committee of the British Association on the "Purification and Utilization of Sewage," effectually disposes of some of the more important objections that have been urged against the use of sewage for fertilizing purposes :

"By properly-conducted sewage irrigation a solution is afforded to the question of sewage utilization. It has already been stated that a precipitation process, or some clarifying process, may be found useful: in

all instances it is essential that the land should be well underdrained, and that the sewage should all pass through the soil, and not merely over it; otherwise, as has been shown, it will only occasionally be satisfactorily purified. The catch-water, or, as the committee has termed it, the "super-saturation" principle, is not defensible either on agricultural, chemical, or sanitary principles. An irrigation farm should therefore carry out intermittent downward filtration on a large scale, so that the sewage may be always thoroughly purified, while at the same time the maximum of utilization is obtained.

"It is certain that all kinds of crops may be grown with sewage, so that the farmer can grow such as he can best sell. Nevertheless, the staple crops must be cattle-food, with occasional crops of corn; and it is also certain, from the analysis of the soil, that it has become very much richer, and that the manurial constituents of the sewage accumulate in it. Cattle should be fed on the farm, which leads to a vast increase in the production of meat and milk, the great desiderata of the population producing the sewage. Thus the system of farming must be specialized and capital concentrated, the absence of which conditions has proved a great barrier to the satisfactory practical solution of the sewage question.

"The committee has not been able to trace any ill effects to the health of the persons living around sewage farms, even when badly conducted; nor is there any proof whatever that vegetables grown thereon are in any way inferior to those grown with other manure. On the contrary, there is plenty of evidence that such vegetables are perfectly suited for the food of man and beast, and that the milk given by cows fed on sewaged grass is perfectly wholesome; thus Mr. Dyke, Medical Officer of Health of Merthyr Tydfil, states that, since the abundant supply of milk from the cows fed on irrigated grass, the children's mortality has decreased from 48, 50, and 52 per cent. of the total deaths, to only 39 per cent., and that so far from diarrhoea having been made more prevalent by the use of sewaged cabbages, 'last year the Registrar-General called attention to the fact that diarrhoea

was less prevalent in Merthyr than in any place in England and Wales;' and he expressed his belief in 'the perfect salubrity of the vegetable food so grown.'

"With regard to the assumption which has been made that entozoic diseases would be propagated by irrigation, all the evidence that the country has been able to collect, and more especially the positive facts obtained by experiments, are against such an idea; and the committee is of opinion that such disease will certainly not be more readily propagated by sewage irrigation than by the use of human refuse as manure in any other way, and probably less if the precaution be taken of not allowing the animals to graze, but always having the grass cut and carried to them."

#### **Length of Thread of the Silk-worm.—**

Prof. Riley, of St. Louis, informs us that the calculation, on page 663 of the last volume, as to length of thread and weight of cocoon spun by the mulberry silk-worm, is altogether exaggerated. Instead of the thread being 11 miles in length, it averages not much more than half a mile, and seldom exceeds 1,000 yards; while a single mile, instead of 28 miles of it, would weigh about  $15\frac{1}{2}$  grains.

#### **The Constitution of Carboniferous Strata.**

—At a general meeting of the British Association, Prof. W. C. Williamson delivered an interesting discourse on "Coal and Coal Plants." The speaker said that most men are now agreed as to the vegetable origin of coal, and the drift theory of its accumulation. It was once a vegetable soil, which accumulated under the shade of primeval forests, growing on areas of depression. In time the land sank beneath the sea, and the vegetable elements were buried under layers of sand and mud, accumulations of which again restored the area to the sea-level, when spores of plants once more germinated in a blue mud, and the succession of phenomena which had previously occurred was again renewed. The frequent repetition of these changes, finally, resulted in the accumulation of the thousands of feet composing the vertical series of rocks which are termed the carboniferous strata. Attention had been called by Prof. Huxley to some



minute coin-like bodies which are very abundant in some coals, and which had been previously noticed by Witham, Dawson, and others. The larger of these bodies Huxley regarded as spore-cases, and the smaller as spores, while he considered that their disintegration had led in most cases to the formation of the bulk of what we call coal.

Prof. Williamson showed in detail that these were not spore-cases, but two kinds of spores—microspores and macrospores—such as severally occur in the upper and lower portions of the fruits of many living club-mosses. Their sizes and structure demonstrate the truth of this conclusion, which is further sustained by the fact that spore-cases are not deciduous, but spores are; and these objects, having fallen in such vast myriads from gigantic club-mosses, can only have been deciduous organs. The lecturer then gave reasons for concluding that these spores had played a much more limited part in the origin of coal than Huxley had assigned to them. According to Huxley, coal is composed of mineral charcoal and coal proper—the latter term being equivalent to spores altered or unaltered. Prof. Williamson, on the other hand, recognized three such elements: mineral charcoal, that is, fragments of fossil wood retaining its structure; coal proper, that is, mineral charcoal disorganized; and spores in various states.

We now distinguish in coal three groups of fossil plants: 1. Those of which we have the form but not the organization: 2. Those of which we have both form and organization; 3. Those of which we know the structure, but are ignorant of the outward form. What has yet to be done is the correlation of the first and last of these three groups. Brogniart long ago showed that most of the coal-plants were cryptogamic—chiefly calamites (allied to living horse-tails); lepidodendra (represented by the club-mosses); ferns, and plants supposed to represent pines and firs of the group known as gymnospermous exogens.

**Leached Ashes as a Fertilizer.**—In a report to the Connecticut State Board of Agriculture, Prof. S. W. Johnson gives the results of some analyses made by himself of specimens of leached ashes used for fertil-

izing purposes. By these analyses leached ashes are found to contain: less than one per cent. of *potash*; a large proportion of *water* (not less than 35 per cent.); considerable *sand* or *soil*, and *unburned coal*, amounting to from 6 to 15 per cent., when not intentionally or largely adulterated; about 45 per cent. *carbonate of lime*, which is the chief fertilizing element in leached ashes; a little more than 1 per cent. of *phosphoric acid*, and 3 to 4 per cent. of *magnesia*. They contain no *nitrates*, but the carbonate of lime in them favors the development of nitrates when they are incorporated with the soil, especially in conjunction with animal manures.

Prof. Johnson states that the price of this material is 35 cents per 100 lbs., or \$7.00 per ton. Its fertilizing value lies exclusively in the 20 or 30 lbs. of lime,  $3\frac{1}{2}$  of magnesia,  $1\frac{1}{2}$  of phosphoric acid, and 1 or 2 lbs. of potash in each 100 lbs. But these materials may be procured in other forms, as follows: 35 lbs. of fresh-burned oyster-shell, or stone-lime, will furnish the lime; 15 lbs. of any good superphosphate will supply the phosphoric acid; the magnesia and potash together may be obtained in 40 lbs. of German potash salts, and there will then be 4 or 5 lbs. of potash and 6 lbs. of sulphuric acid extra.

If the lime be slaked with water in which the superphosphate and potash salts have been soaked and partially dissolved, the resulting mass will contain not only all the fertilizing elements of 100 lbs. of leached ashes and more, but these elements will be in such a state of fine division as to render the mixture in all respects equal to the ashes themselves.

From these data any one can readily calculate the cost in his own locality of a substitute for leached ashes. "It must not be forgotten," adds Prof. Johnson, "that a mixture made of fresh-burned lime should be allowed to become mild by exposure to the air, or its peculiar effects on the soil should be anticipated and provided for."

**Age of Metamorphic Rocks.**—"The Metamorphism of Rocks" is the title of a paper read at the Association meeting, by Prof. T. Sterry Hunt. The author briefly noticed the changes produced in rocks by

the action of water, air, and various gases. While some geologists had supposed that many of these, such as gneiss, greenstone, serpentine, talcose, and chloritic rocks, were igneous products, more or less modified by subsequent chemical action, others maintained that they were the result of aqueous sedimentation, and subsequently crystallized. This was the teaching of Hutton; and when early in the present century the crystalline rocks of the Alps were shown to rest on uncrystalline fossiliferous strata, it was suggested that the overlying crystalline strata were newer rocks which had undergone a metamorphism, to which those just beneath had not been subjected. This view spread until the great crystalline centre of the Alps was considered to be in part of secondary and even of tertiary age.

The author detailed the course of study by which he was led to question this view, and showed that there is no evidence in the Alps to support it; that Sedgwick and Nicoll had discredited the palæozoic age of the crystalline schists regarded by Murchison as Cambrian and Silurian; and, finally, gave the observations by which he had satisfied himself that the crystalline rocks of the Green and White Mountains, and their representatives in Quebec, New Brunswick, and on the Blue Ridge, were more ancient than the oldest Cambrian or primordial fossiliferous strata.

**Tests for Glycerine.**—The so-called pure glycerine of commerce, according to the *Journal of Applied Chemistry*, is often contaminated with metallic chlorides. Traces of ammonia are also sometimes present; and it not unfrequently contains oxalic acid or soda. The first-named impurity may be detected by diluting the glycerine with twice its volume of water and adding nitrate of silver. If the glycerine only becomes opalescent, the quantity of chlorides is not great enough to be injurious, but, if a flaky precipitate is produced, it indicates that the glycerine is unfit for medicinal use. To detect ammonia, mix the glycerine with its own volume of caustic potash, and bring a glass rod previously dipped in dilute muriatic acid over the mixture. If ammonia is present in injurious quantity, whitish vapors of chloride of ammonium will be formed. Oxalic acid

may be detected, by adding lime-water, acetate of lime, or a mixture of chloride of calcium and acetate of soda. If the glycerine becomes turbid within five minutes after the reagent is added, it should be rejected. Traces of soda can only be revealed by evaporating the glycerine to dryness, and testing the residue.

**American Origin of the Garden Raspberry.**—Although the garden raspberry (*Rubus Ideus*) was imported from Europe, yet Dr. Asa Gray has lately made known some facts that would seem to make it certain that this plant, which is not indigenous to Europe, is a native of Japan and North America. Wild specimens from British America and the Rocky Mountains, it seems, must be referred by the botanist to the cultivated species, *Rubus Ideus*. Prof. Areschoug, who has devoted special study to the *Rubi* of Europe, concludes that this species did not originally have its home in Europe, but that its origin is to be found in the east of Asia, namely, Japan and the adjacent countries, and perhaps in North America. He also thinks that "the Asiatic and North American floras have reciprocally mixed with each other by passing Behring Straits and the islands which in its neighborhood form a bridge between the two continents."

**Rapidity of Vegetable Growth.**—A writer in the *Gardener's Chronicle* gives some illustrations of the prodigious activity manifested in the growth of plants during a few weeks. The process of growth, being gradual and noiseless, and moreover of everyday occurrence, is generally disregarded. And yet, what a quantity of water must be absorbed and exhaled, how much air inhaled and exhaled, how much carbon fixed during the process! The writer gives some measurements of an ordinary plant, the *Abies nordmanniana*, a species of silver-fir, which will give a good idea of the rapidity of growth.

The shrub was only two feet six inches in height, and the number of young shoots of this year's growth on it 585. These shoots vary in length from half an inch to six inches, and their aggregate length is 1,171 inches, or nearly 98 feet. Dividing the aggregate of the shoots (1,171 inches)

by their number (585), we find the mean length of the shoots to be about two inches. The average number of leaves on each inch of a number of shoots, taken at random, was 34, so that the total number of leaves on these 585 shoots may be set down at 39,814. Assuming each leaf to be only one inch in length—which is considerably under the mark, even when all the small, undeveloped leaves are taken into consideration—we should have for the leaves a length of about 3,501 feet, so that, in round numbers, we may say that, including the shoots and leaves, the growth in length alone of this very moderate-sized young tree, during this season, has amounted to the prodigious number of 3,600 feet; and, if the shoots and the leaves could all be placed end to end in a continuous line, they would extend considerably more than half a mile.

**Action of the Sand-blast.**—At a recent meeting of the British Microscopical Society, Mr. Wenham exhibited a piece of glass “ground” by the sand-blast process, which, under the microscope, presented a very different appearance from common ground glass. It is found that the glass or other material, worn away by the sand-blast, is not ground away at all, but broken up by a battering action, similar to that of leaden bullets against a block of granite. Hence it is that, although, by the usual grinding process, ordinary sea-sand can make no impression on corundum, a blast with a pressure of 300 pounds to the square inch will perforate it in a short time. Nay, even the diamond itself may thus be speedily worn away.

A polished glass surface, exposed for an instant to the sand-blast, shows an aggregation of points of impact, from which scales of fractured glass have broken away in an irregular radial direction. It appears as if a pellet of glass had been driven in by the collision of the sand, and the wedge-like action thus set up had driven away the surrounding glass. All these spots, or indentations, when tested by the polariscope, show a colored halo round each, proving that the glass surface is under strain and ready to yield to further fracture. The action, therefore, is not so much due to the hardness of the striking particles as to the

force and velocity of impact. This is sufficiently great to destroy the cohesion of the material operated upon. The external layer is carried against the under stratum, and the material is crushed and disintegrated by a portion of its own body.

---

## NOTES.

DR. CHARLES P. RUSSELL gives a tabulated statement of the mortality of the various States of the Union, from which we borrow the following regarding the death-rates of various cities: The highest death-rate in 1872 was exhibited by Memphis, where the deaths were 46.6 in each 1,000 inhabitants. Other cities followed in this order: Savannah, 39.2; Vicksburg, 36.5; Troy, 34; Hoboken, 32.9; New York, 32.7; Newark, 31.6; New Orleans, 30.6; Boston, 30.5. The rate for Philadelphia was only 26.1; Brooklyn, 28.1; St. Louis, 20.1; Chicago, 27.6; Baltimore, 25.1; Cincinnati, 20.5; San Francisco, 17.2. This compares not unfavorably with the mortuary statistics of British cities, where the lowest rate was 21.4; that of London, Bombay, and Calcutta, show only 29.2 and 25, respectively. The highest known death-rate prevailed in Valparaiso, Chili, 66.9.

INOCULATING the vine with pure essence of *Eucalyptus globulus* is said to be an effectual remedy for the phylloxera or grape-vine disease. The mode of applying the remedy is this: a broad incision is made through the bark at the neck of the vine, in which a few drops of the essence are deposited by means of a small camel's-hair brush. In about three days the phylloxera insect entirely disappears, while the vine is not in the least injured by the operation.

THE practice of ringing and tolling bells by swinging the clapper or tongue violently against the side of the bell while the latter is stationary, is said to be a very frequent cause of fracture. The bell itself should always be in motion when struck by the object that is intended to set it vibrating.

PINE-LEAVES, says the *Mining and Scientific Press*, are largely utilized in Europe. They are converted into a kind of wool or wadding, which is used for upholstery instead of hair. A kind of flannel is also made from this fibre, which is said to be very superior for many hygienic uses, as for rheumatism and skin-diseases. Vests, drawers, loose shirts, etc., are also made of this material. In the process of manufacture an ethereal oil is obtained, very useful as a solvent, and as a curative agent. Gas is made from the refuse, and used for lighting the manufactories; or the entire refuse may be

pressed into the form of bricks, when it becomes an excellent fuel.

THE material used for capping champagne, beer, and mineral-water bottles, supposed to be simply tin-foil, turns out on examination to consist almost entirely of lead. Dr. Wittstein, after analyzing a great many of these capsules, states that the proportion of tin in their composition varies from one to ten per cent., all the rest being lead; and that the prevalent habit of closing the top of the bottle with the cap after the cork has once been drawn is a dangerous one, as the acid contents of the bottles even in minute quantities, in contact with the cap at the mouth of the bottle will rapidly dissolve the lead, and thus give rise to a poisonous solution.

ONE of the most distressing, because rarely remedial forms of chronic mania, says the London *Lancet*, is that produced by the mental shock of fire. The patient wears a peculiar aspect, in which suspicion is one element, and a settled look of panic another. Photographs of such inmates of asylums are remarkably uniform in their representation of this expression. The great fire at Chicago has produced a large number of lunatics, no fewer than 250 sufferers from it having been adjudged insane by the courts of Illinois. Considering the privations, however, to which the houseless victims of that conflagration were in many cases exposed, other causes than fire-panic may be credited with a share of the result.

ACCORDING to Van Beneden, as quoted in the *American Naturalist*, an excellent method of preparing for preservation and study such jelly-like and perishable organisms as medusæ, ctenophora, noctilucae, etc., is to immerse them for from fifteen to twenty-five minutes, when fresh, in a weak solution of osmic acid, when, after washing several times in water, they may be kept, for weeks or months without impairment, in alcohol. The acid colors a portion of the tissues brown, but this rather facilitates than hinders study, as it brings into view certain structures that are otherwise less clearly visible. The agent also hardens the substance of the animal, so that it may be handled without danger of disorganization, and readily cut into sections if desired.

FEVER is the most prolific cause of death in India, and, in ordinary years, carries off many more victims than all other diseases together. The returns, exclusive of Bengal and the northwest provinces and Burmah, give upward of 900,000 deaths from fever in 1871, and the total number in all India cannot be far short of 1,500,000. At least half of these lives might be saved by putting quinine in every native druggist's shop at one rupee per ounce.

THE United States Light-house Board have under charge 179 sea and lake coast lights, 394 river and harbor lights, 22 light-ships, and 33 fog-signals, that are operated by steam or hot-air engines.

THE *Gazette des Campagnes* recommends dipping the end of plant-slips in collodion before setting them out. The collodion should contain twice as much cotton as the ordinary material used in photography. Let the first coat dry, and then dip again. After planting the slip, the development of the roots will take place very promptly. The method is said to be particularly efficacious with woody slips, geraniums, fuchsias, and similar plants.

CHLORIDE of cobalt, sometimes used as the basis of a sympathetic ink, is, according to Siegen, a powerful poison. A grain killed a frog in half an hour. Four and a half grains killed a strong rabbit in three hours. The poison acts directly upon the muscles of the heart. Nitrate of cobalt is equally poisonous, and acts in a similar way.

CAMPBOR-WOOD promises to become, at no distant day, an important article of commerce. It grows freely in tropical countries, without cultivation. The tree attains large proportions, being sometimes found fifteen feet and upward in diameter, and of proportionate height. It is very valuable for carpenter's work, being light, durable, and not liable to injury from insects. Its aromatic perfume is well known. The wood is strong and very durable, and is especially serviceable in ship-building. Camphor-wood piles have been known to remain in a good state of preservation over a hundred years.

IXTLE-FIBRE, which grows abundantly on the southern shores of the Gulf of Mexico, is remarkable for its lustre, strength, and flexibility. Within the thin envelope which forms the leaf, there is a perfect skein of thread of extraordinary tenacity, length, and fineness. The outer covering can be easily removed by a chemical process, and the whole fibre made available without further expense. The plant, it is said, can be brought to New York for less than fifty dollars per ton.

IN a French industrial establishment, employing 630 men, chiefly vegetarians, the sick fund was constantly in debt. The director of the establishment took measures for the introduction of butcher's meat into the food of the men, and the effect was such that the average loss of time per man, on account of illness or fatigue, was reduced from fifteen to three days per annum. Thus the animal food saved twelve days' work a year per man.

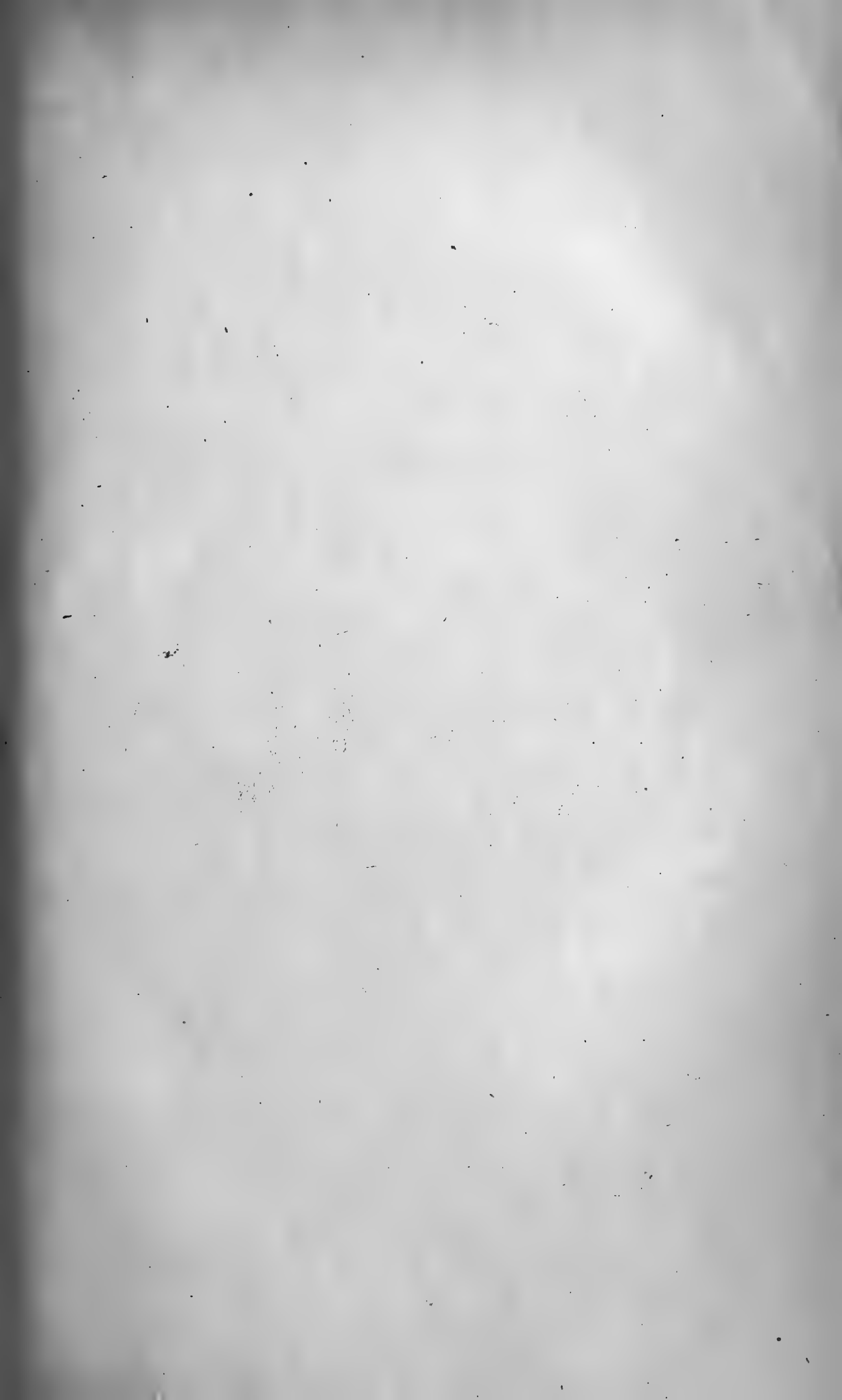



LOUIS JEAN RUDOLPH AGASSIZ.



THE  
POPULAR SCIENCE  
MONTHLY.

---

MARCH, 1874.

---

THE WORLD BEFORE THE INTRODUCTION OF LIFE.

BY CHARLES H. HITCHCOCK, A. M., PH. D.,  
PROFESSOR OF GEOLOGY IN DARTMOUTH COLLEGE.

THE few hints afforded by geology respecting the earliest stages of the earth's history, when compared with studies into the nature of nebulæ, comets, and suns, suggest the existence of a series of mutations through which worlds destined for the occupation of intelligent beings must pass, in order to be properly fitted for the residence of mind. There is, first, existence as a nebula, or comet; second, the condition of a burning sun; third, a stage of refrigeration; fourth, a period of habitation by the brute creation; fifth, a time of occupancy by reasoning, moral beings; and, perhaps, sixth, a stage of frigidity, impoverishment, and extinction of life. Our planet seems to have passed through four of these stages of growth, with the fifth well advanced toward its meridian.

The history of the world might be correlated with a certain species of organic cycle, the growth of grain. There is presented to us a kernel of corn containing within itself the elements of vital action. So long as it is stored in a granary it is quiescent, but when planted in the soil it germinates, producing first the tender blade, then the tasseled tops, the silky ears, and, finally, rows of mature kernels upon the spike, inclosed by a sheathy covering. As soon as the seed is properly situated for development, an inward impulse urges onward the growth till the process is completed.

Alike fraught with instinct has been the serial progress of the earth. It first presents itself to view simply as a mass of inorganic material, a heterogeneous mixture of elements, inert and motionless, the "chaos" of theological writers. But this material is endowed with activity; the atoms possess affinities for one another, and the mass cannot remain motionless in space, surrounded by worlds and systems. Gravitation causes the mass to rotate upon its axis and to

revolve about other bodies, and chemical affinity unites the atoms into compounds. Henceforth there will be no cessation of activity till the mature condition, it may be of eternal desolation, has been attained.

FIG. 1.

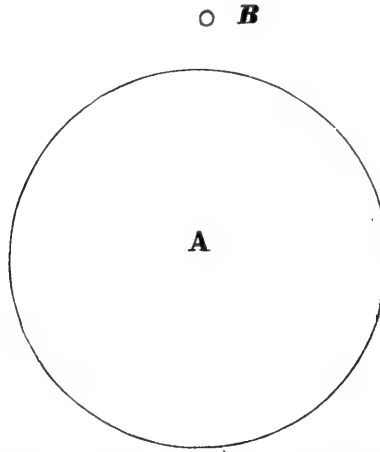

A—SIZE OF EARTH WHEN IN THE NEBULOUS PERIOD, COMPARED WITH ITS PRESENT DIAMETER, AS SHOWN BY B.

Bernard von Cotta styles these successive phases of development *stadia*, and reduces their number to seven. He conceives that during the first stadium only one agency—gravitation—acted upon matter, the results being a spherical aggregation of the particles and the production of an intense degree of heat. The second stadium adds to gravitation the agency of heat and other physical forces. In the third, chemical affinities are developed, and a cooling globe is the sphere of their action. The fourth stadium brings to view water, with its ability to accumulate formations by deposition of detritus. In the fifth, life and the power of organization are introduced. In the sixth, ice first appears. Last of all comes Mind, the other activities being present also with it.

This theory is beautifully elaborated in his interesting memoir; but its consistency with the following statement is not readily perceived: “Since the history of the development of matter is for us absolutely an infinite series, it is impossible to recognize, or even to conceive, a real beginning of things. We must enter arbitrarily into the infinite series of events, and follow it from that point down to the present time.” The organic cycle commencing with the kernel of corn may repeat itself endlessly; but we demand, eventually, whence came the first seed? So we can follow back the grand cosmical series of mutations to a point antecedent to which there is nothing rational but the presence of the Infinite Mind, the same that sustains all Nature in its present activity. Progress implies a beginning. Following out the argument to its legitimate extent, we are forced to the conclusion that the Almighty actually created the material of the solar system out of nothing. Matter could not have existed from eternity, else the

phases of growth had all been completed, and we should have passed beyond the period of organic activity. The New-Zealander would have leaped over the ruins of London, and the "last man" of Hogarth would have finished gazing upon the ruins of intellectual activity.

FIG. 2.

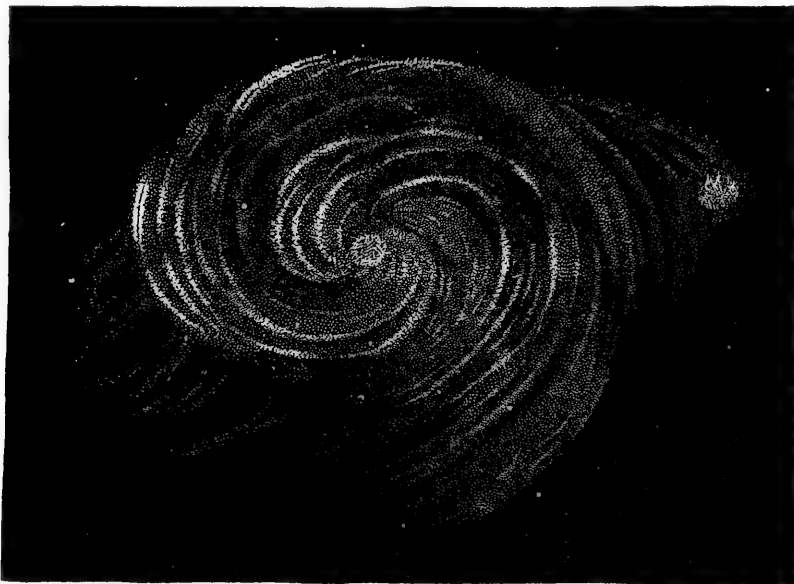

SPIRAL NEBULA IN CANES VENATICI (H., 1622).

COSMICAL ANALOGIES.—Space is full of bodies resembling our earth in all stages of its growth. The earlier stages are displayed in nebulae, comets, and suns. The former, by the improved methods of modern investigation, are clearly shown to be in a gaseous condition, intensely heated, though not so hot as the sun, and so tenuous that the brightness of the stars behind is hardly dimmed.

There has been great progress in the study of the nebulae. Many had been resolved into clusters of small stars by the more powerful instruments of recent manufacture, so that astronomers doubted the existence of any unresolvable forms. But, in 1866, Mr. William Huggins showed that nineteen out of the sixty nebulae seen through the great reflecting telescope of the Earl of Rosse presented spectra exhibiting the bright bands indicative of heated luminous gas. Hence the world could no longer doubt the settlement of the question whether any of the nebulae are composed of vapors. Prof. Young says that the majority of the nearly 8,000 known nebulae are luminous clouds of heated gas, with minute solid and liquid particles scattered through them. In a recent number of *THE POPULAR SCIENCE MONTHLY*, Mr. F. W. Clarke has classified these bodies, suggesting that there may be a law of development among them. The most distinct are composed of nitrogen and hydrogen, possessing a temperature beneath that of the sun. He propounds the hypothesis whether nebulae may not pass by degrees into suns, the sixteen elements known to exist in

the latter class having been evolved by degrees from the original simple gases of the nebulæ. This is a problem well worthy the study of chemists.

The comets differ from nebulæ by possessing a bright, star-like nucleus, apparently more solid than the surrounding coma or brush trailing behind. The spectroscope indicates that the entire material of comets is similar to the gaseous nebulæ. Possibly their nuclei are centres of attraction around which the heavier atoms are gradually falling, "granulating into star-dust," in the process of transition from nebulæ to suns.

Foremost among the worlds comparable with our planet, when in the condition of igneous fluidity, is the centre of our own solar system. Though fourteen hundred million times larger than the earth, the sun possesses only one-fourth the density of our world, being a trifle heavier than water. The hourly radiation of heat from each square foot of his surface is equal to the combustion of 130,000 pounds of bituminous coal. This is abundantly adequate to heat and illuminate all bodies in space within hundreds of millions of miles from his surface. Suns like this are to be enumerated by the thousand in the heavens, all of them doubtless the centres of other star-systems, imparting light and heat to numberless planets.

It is less easy to determine the character of worlds in the former condition of ours, just incrustated after igneous fluidity, no longer a sun, but shining by borrowed light reflected from some greater sphere, because they are wrapped in an opaque envelope. The moon, whose proximity enables us to inspect her hills, craters, and valleys, appears to have been thoroughly cooled from fusion. She is solid to the core, and has approximated to that final period of barren desolation not yet attained by the earth. Most of the outer planets, Jupiter, Saturn,

FIG. 3.

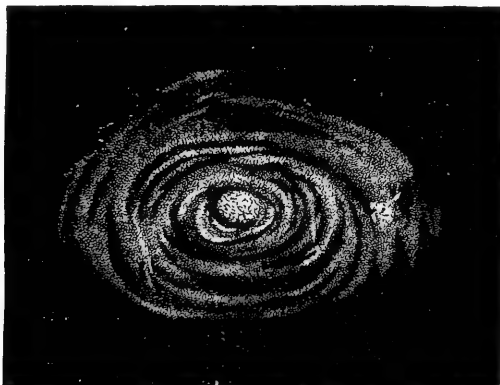

TRANSITION FROM THE SPIRAL TO THE ANNULAR FORM.

Uranus, and Neptune, have a small specific gravity; but we cannot tell whether they have advanced beyond us in the cycle of progress, or whether they are yet immature. The adjacent planets, Venus and

Mars, may be more like the earth, and fitted to support animal and vegetable life. If not inhabited by human beings, they may be passing through their preliminary Paleozoic, Mesozoic, or Cenozoic stages. And there are, probably, though their names are unknown to us, in the distant regions of space, deriving light and heat from suns seeming mere points to us, worlds where the early Eozoön rears its calcareous reefs, the gigantic Labyrinthodon croaks amid the primeval quagmires, and the Connecticut birds are leaving upon the marine mud the imprints of their tridactyle feet. Nor is it unlikely that other species of men inhabit some of these scattering orbs, and are as curious about us and our institutions as we are about them.

**THE NEBULOUS PERIOD.**—The usual geological argument for nebulousness is derived from the attempt to understand the origin of the condition of igneous fluidity. If the earth has been cooling from fusion, perhaps this is a cooler condition than the still earlier hotter state of fiery gas. Solids expand into liquids when heated, and liquids may become gases for the same reason. This gas, however, may not necessarily have been hotter than when condensed. The particles of matter must be the same when volatilized, as in both the liquid and solid states. Every substance now existing beneath the atmosphere must have been present—the compact ledges of the firmly-seated hills—the stone-walls of ancient cities—the water of the ocean—the oily fluid spouting from the bore-holes of Western Pennsylvania—the very particles of the paper containing this sentence printed upon it—and even the elemental constituents of our bodies, so fearfully and wonderfully made—all these and every thing material may have been commingled with the atmosphere, hovering about in a vaporous form, the components of a nebula, or comet.

In the attempt to surmise the actual condition of the elements at the beginning of the nebulous period, two views may be held, according as we prefer to adopt a chemical or mechanical theory of their origin. If one does not care to imagine the atoms called into existence in a heated condition, he may suppose that matter first appeared with the common frigid temperature of space, or about one hundred degrees Fahrenheit below the freezing-point of water, and that the elements were uncombined. Newly born, these particles would immediately commence to display their affinities, and the result would be explosive combinations, giving off intense light and heat. The latter force permeating the elements, would soon reduce them, first to igneous fluidity, and then into heated vapors. Every atom flying away from every other one, on the principle of “dissociation,” would give rise to a nebula of enormous dimensions in a comparatively short time from these cosmic materials. After the formation of the nebula, the series of changes about to be described would commence its rounds.

A mechanical theory is presented by the distinguished philosopher, Dr. J. R. Mayer, author of a treatise upon “Celestial Dynamics.”

He assumes that our globe was once very much smaller than it is at present, and that independent masses of matter, perhaps other planets, have fallen upon it, the shock of collision generating an enormous degree of heat. This is an effect of the "crush of worlds" not commonly apprehended. If two bodies, conjointly equal to the bulk of the earth, were rapidly traveling through space, and should violently come together, their collision would evolve enough heat to convert the united mass into lava, or heated vapor. An asteroid falling upon the sun would generate from 4,600 to 9,200 times as much heat as would come from the combustion of an equal mass of bituminous coal, the force of velocity changing into caloric. This view, though adequate to explain the origin of the nebula, does not account for the existence of the colliding bodies. It might be consistent with the doctrine of the eternity of matter, in which case the colliding planets may have been coursing about the sun for myriads of ages as aggregations of matter corresponding to the last term of the great cosmic cycle—inorganic sterility. Could we understand how all the planets might eventually fall into the sun, we might suppose the present series of changes is only one of several cycles, in agreement with the speculations of certain writers.

Dr. Mayer carries his theory much farther. He does not confine these cataclysmic unions to the ante-nebulous periods. It is suggested that there may have been similar accretions to the surface of our planet after the introduction of life. A luxuriant vegetation, or a thickly-peopled continent, may have been often buried beneath the fiery *débris* resulting from the conflict. There are frequent occurrences of a similar character at the present day, but of trifling influence upon the general temperature. Every solid meteor that falls from the sky develops heat; and it cannot be denied that, were these bodies of large size, the calamitous occurrences depicted by Dr. Mayer would be experienced. Each one of these cataclysms would interrupt the cycle of progress as set forth above, and carry the order of the mutations back to the beginning.

When we study the scheme of worlds revolving around the sun, we discover that they all rotate on their axes in the same direction; that they all proceed from west to east, their orbits being nearly circular, and in almost the same plane, which is nearly coincident with that of the sun; that the sun moves on his axis in less time than any of the planets, and each planet rotates more quickly than its satellite. These and other facts point out a community of origin and development inexplicable by chance or the law of gravitation. We suppose, then, that the sun and all the planets and their satellites composed originally a single mass of luminous fog, with a diameter exceeding that of the orbit of Neptune, the remotest planet, or not less than three thousand million miles. This would correspond well with the supposed dimensions of the smaller nebulæ now seen in the skies. The



history of the earth at this early period was, therefore, merged in that of the solar system.

The centrifugal force produced by rotation would cause rings of gaseous matter to separate themselves one after another from the central mass, the latter turning on its axis more rapidly after the removal of the exterior. The separated ring would then have been an annular nebula. As many as six rings must have been cooled before the earth-mass separated itself from the interior sphere carrying the substance of the sun, and the inferior planets.

The next stage of growth would naturally consist in the breaking up of each ring by itself, perhaps in consequence of inequalities in different parts, and condensation into a sphere of greater specific gravity. The falling of the particles would add heat, and perhaps quickly induce the fluidity of the mass. While still gaseous, other rings may fly off, to become satellites. All the nebulae, by constant rotation, may have given freedom to the contained particles to arrange themselves according to their relative densities, the heaviest atoms falling to the centre, and the lightest remaining at the surface. The process of separation into zones must have been analogous to the cooling of liquids. As fast as their superior density caused particles to descend, the lighter atoms would be displaced and sent to the surface, either to be cooled, or to remain permanently in a higher stratum. But, at the close of this period, there must have been, outside of the fluid, an enormous thickness of gases which did not liquefy till after the crust had formed to a considerable amount.

PERIOD OF IGNEOUS FLUIDITY.—At the commencement of this period the earth seems to have been a flattened sphere, composed of melted matter like lava, encircled by steam and easily-volatilized liquids and solids, but girdled externally by an atmosphere; rotating upon its axis and revolving round the central sun. It was a sun of itself, emitting light and heat, thus forbidding the distinction of day and night, though the planetary movements inducing the alternations of position were as well marked as now. The several compounds constituting the material of the earth were probably arranged in concentric zones according to their relative gravities, just as we now observe the settlings in a copper or iron furnace. A general mixture of rich and poor ores, fluxes and fuel, is put into the receiving-vault; when ignited, the solids mix together, melt into a fluid, the heavier metals sinking to the bottom, and the slags rising to the surface to be skimmed off. So the metals would naturally gravitate to the centre of the fluid earth, and around them might be several zones of successively lighter compounds, the exterior being the least heavy of all, and answering to the slags of the furnace. The specific gravity of the whole earth is now 5.65, when compared with water, as determined from astronomical sources; but that of the surface-rocks is less than half this amount: hence we have abundant reason to believe that the

same general relation of light and heavy zones still exists, and that the deeper we descend the more abundant the proportion of the denser metals. The germ of this arrangement was undoubtedly induced in the nebulous age. The compression of the surface-elements into a quarter or half their known bulk cannot explain the great weight of the interior, for experiments indicate that a limit to the capacity of reduction of volume is soon reached. So far as we know, the reduction of bulk by pressure becomes less and less in proportion to the pressure exerted.

FIG. 4.

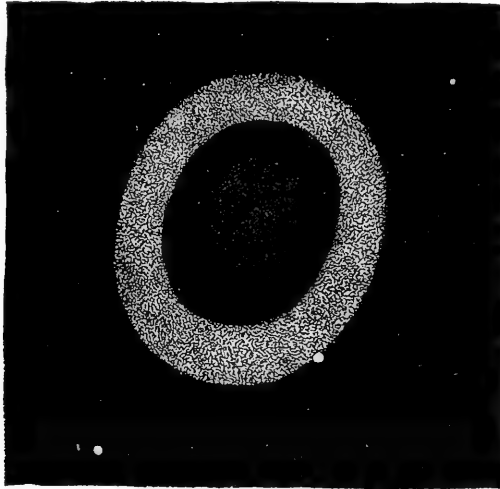

ANNULAR NEBULA IN LYRA.

Some interesting observations have recently been made by Prof. Daubrée, of Paris, upon the analogy between certain terrestrial rocks and the heavy meteoric stones which occasionally fall from the sky. Some of the meteorites are nearly pure iron; others either contain grains of minerals like olivine, or consist chiefly of the olivine, with only occasional particles of iron. This latter class are silicates of magnesia and the protoxide of iron, allied to the minerals olivine or peridot, and a granular compound of anorthite and pyroxene. Patrin, so long ago as 1809, called the attention of observers to the identity between the composition of certain meteors and substances ejected from volcanoes; and, in 1858, Von Reichenbach sketched theoretically some of the conclusions just arrived at experimentally by Daubrée. Reichenbach showed that most of the mineral species found in meteors existed also in the trap called dolerite; hence he inferred that masses of material allied to the stony meteors are located deep down under the volcanoes whence the lava was derived. Daubrée has manufactured in the furnace masses apparently identical, both with the metallic and stony meteors. The latter were most successfully imitated by melting down the mineral compounds peridot, Chertolite, hypersthene, basalt, and melaphyre. Allied to them is the dumite of New Zealand, an aggregate of olivine and chromite.

The Chertzolite, a volcanic aggregate of peridot, enstatite, and pyroxene, from the Pyrenees, in Spain, presented, after fusion, specimens the most like the meteorites. These experiments suggest that the meteors had once been fused, as is commonly believed, and that the slight differences existing between them and the peridotie rocks may be explained by supposing the latter to have cooled in the presence of oxygen (or air), while the former may have solidified where the supply of oxygen was limited. When melted, the two mixtures are precisely alike, and we may conceive of the existence beneath us, in the great caldron whence the volcanoes derive their lava, of a zone of meteor-like mixtures, both the peridoties which are now melted and occasionally brought to the surface, and the heavier metallic masses, too deeply seated to be ejected by any convulsive throb of our planet. For aught we can say, the heavier meteors may indicate the exact character of the interior nucleus, just as those black stones falling from the sky have revealed the composition of other worlds. Their weight would correspond well with that of the interior mass. The specific gravity of granite is from 2.64 to 2.76; of basalt, 2.9 to 3.1; the peridoties, 3.3 to 3.44; and the heavy meteors from 7 to 8. Hence, while the granitic

FIG. 5.

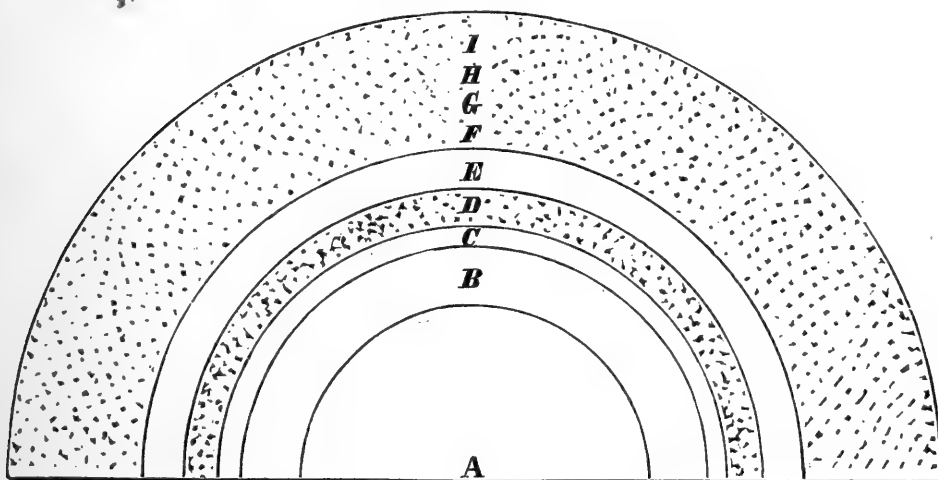

ZONES IN THE EARTH AND ATMOSPHERE.

A. Solid Nucleus of Heavy Metals or Meteors; B. Region of Stony Meteors; C. Region of Lava; D. Region of Basalt and Pophyry; E. Region of Granite, and Surface of the Solid Crust; F. Region of Acid Gases; G. Region of Carbonic Acid; H. Region of Nitrogen and Oxygen; I. Steam.

materials may have cooled near the surface, and the basalts lower down, the stony meteors would form a zone beneath the second, and the metallic masses, if present, may constitute the central nucleus. We must not forget the trachytes, and most modern lavas, which would underlie the basalts. It would be easy to calculate the thickness required for these different zones, whose general average should be the density of the earth. When water is added to the peridoties and stone-meteorites, the rock is analogous to serpentine. We may

remark that the crust abounds most in the oxides of those metals which have the strongest affinity for oxygen, as the alkalis and alkaline earths; while in the peridotite and lower zones the proportion of these elements is much less, and that of the earths and metals is much greater. The minerals composing the superficial crystalline rocks, as well as water, are generally absent from the meteorites. This is especially noticed in respect to the mineral quartz or silica, so common at the surface. According to these views, the granites must once have been in a melted condition, and the excess of silica present in them have assumed the amorphous form. Many geologists have supposed the silica ought to have crystallized first, if the rock cooled from fusion. It may be that our ideas of the intense heat have been exaggerated; yet the Labrador granites of New Hampshire have recently been shown by us to be situated in sheets over a plain, precisely like the erupted lava of the present day.

We have dwelt upon the present concentric structure of the earth, because it was probably the same with that existing in the igneous period, at that time fused, but now largely solid. The order of the alternations has always been the same. It corresponds also with that observed in furnaces, where the metal sinks to the bottom, and is overlaid by one or more successive layers of slag.

This complex sphere, when molten, with its fiery billows and igneous currents, being situated in a fearfully cold region, could not fail to radiate heat; and, like other melted bodies, become covered with a congealed crust. A pot of melted iron taken out of the fire loses heat, and a crust speedily forms over it, shrinking as it cools; and, if the exterior be broken, the red liquid may be poured out. The same thing may be seen on the dumping-heaps connected with melting-works. Masses of slag, with their entire surface congealed, are placed upon the car and wheeled to the end of the pile; but, when thrown down the slope, they are fractured, and the liquid interior flows out like water. When a stream of lava flows down a slope, the surface and sides of the molten river are soon covered by a thick crust, the result of cooling. This will become so firm that men may walk upon it, as upon ice over lakes in the winter. During one of the eruptions from Vesuvius, when lava covered the town of Resina—the old Herculaneum—some of the inhabitants, driven to the tops of the houses, escaped by walking over the stiffened crust, before the flow had ceased. Whenever the lateral walls of the stream are broken, the lava will flow out and change its course. In this way, a current threatening to engulf a village may be averted and directed elsewhere. This is a practical matter, and has been turned to account in Sicily, in warding off from Catania the threatened calamity rolling down the slopes of Etna.

Our entire experience, therefore, of analogous phenomena, leads us to believe that a crust will be formed, and that the several zones will cool in natural order in later periods. Not till the last melted layer

between the crust and solid nucleus has solidified, will eruptions of lava cease to flow from volcanoes.

As time progressed this congealed crust would increase in thickness. Being unyielding, there would be stamped upon it, as plainly as the form of a pitcher by the moulder, the peculiar flattening of the earth, as determined by the rate of rotation. As soon as the internal fires were concealed, the rotation of the earth would give rise to the alternation of day and night—not, certainly, of the same length as now, since the bulk of the sphere was greater, and with a reduction of size the tendency is to an increase in the rate of rotation. But, with the thick atmosphere, the days must have been dark and gloomy.

At the present day the attraction of the sun and moon produces the phenomena of the tides. As the crust is rigid, only the water upon it can now be moulded into different shapes. But, when the whole earth was pliable, its form must have varied daily, much more symmetrically than at present. As the outer envelope stiffened by cooling, tidal waves would form with great difficulty, and eventually the crust would become too rigid to be affected. Perfect rigidity was not attained during the whole inorganic period. While thin, the crust may have been broken by the attraction, and the liquid oozed out through the crevices, overflowing the surface, and returning at low tide. So great is the power of tidal attraction that a rigid envelope, hundreds of miles in thickness, would be fractured by it. The rents formed were like the faults observed in the strata of the organic periods. More or less fracture probably attended every tidal attraction, until the ocean covered the surface, and presented a material easily modulated.

**AGE OF CHEMICAL CHANGES.**—Following the age of igneous fluidity there succeeded another of great interest. It opens with the surface dry, rough, and slaggy; the interior in intense fusion, and the atmosphere containing all the water of the ocean with numerous volatile compounds. Before its close an ocean is formed, most of the gases have left the atmosphere, and chemical agencies acted with great intensity, and so universally as to characterize the period. The falling of the primeval rain dissolved acids in the air, and poured upon the elements never exposed to moisture streams of acidulous waters, well fitted to dissolve out large portions of the original crust.

In order to ascertain the character of this primitive rock, we must adopt the method suggested by Sterry Hunt, in his lecture before the Royal Institution of Great Britain, and consider what changes would result if intense heat should now act upon the crust. The water everywhere would be evaporated, leaving behind its saline impurities. All the carbon in living plants, and the immense supplies of coal stored up in the earth, would become converted into carbonic acid; the siliceous parts, fused with limestones and other rocks, would make silicates of lime, magnesia, etc., and expel the carbonic acid. The sulphur would form sulphurous acid with oxygen, changing eventually

into sulphuric acid as the temperature moderated. Inasmuch as sea-salt, water and silica, when heated together in a confined space, form hydrochloric acid and sodium silicate, it is probable that in these early times the saline residues were decomposed, and the chlorine set free to combine with the hydrogen, and thus manufacture hydrochloric acid on a large scale. The solid bases, therefore—lime, magnesia, soda, potash, and the metals—would be combined into a great slag, and various minerals would crystallize out from it while cooling. By loss of heat the slag would contract irregularly, and there would be inequalities upon the surface, hills and valleys without system or order.

Some authors think the salt would be volatilized, and form a zone at the base of the atmosphere. The papers of Hunt, Forbes, Wurtz, Winchell, and others, show that authors cannot yet agree upon the details of those wonderful changes. The sources of our information are meagre, and the opportunity for diverse views is easy, where such immense periods of time are concerned, so that this discordance is not strange. We cannot regard Dr. Hunt's illustration as perfect, since the earth may never have been a fused mass of equal density throughout, the concentric zones having been essentially segregated in the nebulous period.

The atmosphere may possibly have been arranged in zones. Containing the present gases encircling the crust, the carbonic acid derived from coal and the carbonates, the sulphurous and hydrochloric acids, water converted into steam, and possibly volatilizable compounds, it would constitute an atmosphere of extraordinary density and insalubrity, perhaps six or seven times heavier than at present. We may suppose that the law of diffusion of gases is subordinate to that of gravitation; whence there would result four zones, viz., sulphuric and hydrochloric acids at the base, surmounted first by carbonic acid, and then by a mixture of nitrogen and oxygen; and, lastly, by steam. This dense gaseous covering would prevent much of the radiation of heat from the earth, and produce a universal tropical climate.

As the steam lies nearest the cooling influences of space, it would be the first to be affected by radiation. Drops of water would aggregate and descend, which would be vaporized again explosively, when brought in contact with hot surfaces. The cooling influence increasing its power, the number of falling drops increases, but they continuously return to the outer envelope, till the crust is sufficiently thick and cool to retain them. Thus, at the beginning of this age, there was a terrible conflict between the clouds and the earth, the former pouring down streams of water, which the latter refuse to receive; but the clouds eventually gain the mastery, and the earth sullenly evolves simmering masses of vapor from a hot-water bath.

Imagine, now, the earth capable of holding the falling drops. The water will descend in torrents, for there is to be a transference of the entire ocean from the upper atmospheric zone to the solid earth, where it



properly belongs; the waters above are to be separated by the "firmament" from the seas beneath. Next, we may observe chemical reactions. The condensed steam, in falling through the lower zones, would dissolve the sulphuric and hydrochloric gases, and convert the rain into powerful acids. When these fall upon the slaggy crust, the excrescences will not only be removed, to be deposited as sediment in the hollows, but a large percentage of the surface will enter into solution, giving rise, not to an acid ocean, but one containing sulphates and chlorides. The more soluble silicates would be converted into chlorides, leaving upon the slaggy floor piles of silica. The sulphates may have been largely of the heavier metals, not excluding the others.

FIG. 6.



PRIMEVAL RAIN.

Prof. Wurtz thinks the first ocean would be characterized by the predominance of sulphates. Granting this, we can understand the conversion of the sulphates into sulphurets in subsequent periods, as well as into gypsum. Aqueous deposits of sulphurets of copper, iron, lead, antimony, etc., are common in Eozoic and Paleozoic strata. The action of carbonic acid must not be overlooked. The liquid acids may have disintegrated the silicates of the alkalies and alkaline earths; but the compounds of silica, with alumina and iron, are not so easily decomposed. As soon as the carbonic acid could act upon feldspar compounds, we should have the potash and soda dissolved out as carbon-

ates, leaving behind heaps of kaolin clays, such as now form, for the same reason, from the decomposition of granite. This reaction is one peculiar to dry land, and would therefore be subsequent in time to the changes already mentioned. Now, the potassium and sodium carbonates, when brought into contact with calcium chlorides, change their composition, and there result calcium carbonates and sodium and potassium chlorides. These carbonates, being insoluble, will be precipitated to the bottom, and thus will be formed the primitive travertines and limestones, while the sodium chlorides remain in solution to this day, save what has been converted into beds of rock-salt.

With the removal of the bulk of the acids and possible volatile compounds from the atmosphere, only carbonic acid would remain to render it impure at the close of the era of chemical changes. In later periods this part of the atmosphere has also been removed. The world is not yet ready for life, as there must be further chemical and mechanical changes.

**THE FORMATION OF SEDIMENTS.**—The next era brings into play a phase of action destined to be the chief agent of change in the world—the erosion of existing ledges to form new rocks. The era opens with a continuation of the atmospheric decompositions, whereby we find silica and alumina remaining in irregular heaps of sand and clay, and the accumulation of calcareous deposits beneath the ocean.

The formation of thick deposits of inorganic limestone is extremely interesting. Scientists have been wont to ignore altogether the existence of any deposit of this character, since microscopic researches into the structure of many of the calcareous masses exposed at the surface indicate an organic origin. So many shells and coral fragments aid in building up fossiliferous limestone that its mode of growth is very clear. But, after one has spent months in searching vainly for traces of organisms among the marble layers of Western Vermont, or the auroral limestones of Eastern Pennsylvania, he is tempted to suspect that some of the Silurian limestones even were chemical deposits, though wanting the concentric structure of stalagmite and travertine. But, barring these, and the calcareous dikes in the Laurentian of Northern New York, and in the Silurian beds of Northern Vermont, all the phenomena are best explained by the presence of an inorganic limestone before the origin of life. Whence came the materials for the stony habitations of marine animals? There must have existed great masses of the crude material, stored up in the rocks and in the waters of the sea, to provide with coverings all the testacea of every age, and to furnish the thousands of feet thickness of the Eozoic, Paleozoic, and Mesozoic limestones. This primitive source of supply is now concealed, but much of its material has been used over and over again.

We have suggested how three of the principal rock-materials have been formed—the quartz, clay, and limestone. We have them yet as rude piles of rubbish, neither arranged in layers nor possessing any

determinate form. Next comes the history of the processes by which system is induced. There were hollows and valleys in those early times, most probably vast and deep, but not irregular. The constant fall of rain must originate brooks and streams, coursing their downward way toward the lowest levels. Animated with this descending impulse, they remove barriers at the outlets of lakes and pools, excavate gorges through ridges of impediment, and wear off numerous fragments from every projecting point. This eroded material would be urged forward by the current till the lowest possible level was reached, probably the bottom of an arm of the sea or bay, and remain there while the basin was filling up. Thus we should have a *formation*, composed of layers of the sand, clay, and limestone, originally a chemical precipitate, but now altered into sedimentary deposits. When the first accessible hollows had been filled up, a great interval of time had elapsed, and the external envelope of the earth would shrink, on account of its refrigeration, and fall upon the collapsed nucleus. Hence new valleys would be formed, and the streams would carry the detritus into them, and another set of strata lying upon the edges of the first formation would be deposited. This process has been going on uninterruptedly from that day to the present, and the face of the earth has been changed a hundred times. How long this process went on before the introduction of life it is impossible to say, for the oldest strata known to exist contain the remains of the Eozoic reef-building colonies, in the formations known as the Laurentian.

As some of the older Laurentian beds are composed of pebbles, it is obvious that earlier formations exist, from which the sedimentary material has been derived. Possibly we may be able ultimately to separate from the various systems of the age under consideration those characterized by the presence of the first existing plants—since in the order of Nature there must have been plants before animals. If we follow the analogy of the duration of the earlier periods, we may believe that this *Eophytic* age exceeded the Eozoic in length; and, furthermore, that the time before the introduction of life was far greater than what has lapsed subsequently. If the law admits of universal application, that the simpler the organism the longer it has lived, then we may perhaps claim that the earlier the period the greater has been its duration. The extent of work performed in these early ages has certainly far exceeded any thing yet known of the operations in the Zoic periods.

The series of changes prior to the introduction of life may therefore be registered as distinct ages, as well marked by special features and a natural order of succession as the periods defined by Paleontology. The minute details of the history are wanting, but, with such substantial bases of probability as have been set forth, human thought will construct theoretical systems that will command universal acceptance.

As now understood, the following titles may express the characteristic features of all the great ages of the world, from the birth of matter to the advent of man :

MATTER CONVERTED INTO VAPORS.

NEBULA COMPOSED OF THE ENTIRE SOLAR SYSTEM.

THE EARTH-NEBULA.

PERIOD OF IGNEOUS FLUIDITY.

AGE OF CHEMICAL CHANGES.

BEGINNING OF THE SEDIMENTARY PERIOD.

INTRODUCTION OF VEGETATION ; or, Eophytic Period.

INTRODUCTION OF ANIMAL LIFE ; or, Eozoic Period.

PALEOZOIC ERA.

MESOZOIC ERA.

CENOZOIC ERA, COMPLETED BY THE ADVENT OF MAN.

---

## WALKING, SWIMMING, AND FLYING.

BY E. LEWIS, JR.

THROUGHOUT the realms of Nature motion is indispensable to physical stability and organic existence. It is everywhere present, and equally among molecules and masses the mind searches in vain for evidence of absolute rest. It has been declared that "organic life is a result of motion ;" certain it is that motion is a condition of life. It appears in the endless manifestations of beauty and utility, in the world of living creatures of which ourselves are a part. The heavens are more beautiful when clouds are drifting, and the motions of animals give a charm to a landscape which disappears in the solitude of a desert. Stillness to the eye, like silence to the ear, becomes at last painfully oppressive. We scarcely realize, perhaps we seldom consider, how much of the joy and value of existence depends upon the movement of beings, and the marvelous perfection of the means by which it is effected. Walking, swimming, and flying, are the means by which we traverse the three great highways of Nature—the land, the water, and the air. If we change our position, it is in one or other of these. There is no more fascinating chapter of science than this. The mere fact of animal locomotion is felt to be an expression of beneficence, and of adaptation of means to ends which surpasses human ingenuity.

What laws of motion are revealed, what principles of mechanics are brought into action, when animals walk, swim, or fly, has been discussed by many writers, but by none in a more able or interesting manner than by Dr. Pettigrew, who, in a volume soon to appear in

the International Series, has given the results of a long course of observations and study upon the subject.<sup>1</sup>

The three modes of progression, apparently so unlike, are nevertheless essentially the same. The limbs of the quadruped, the wings of the bird, and the fins of the fish, are built upon the same general plan of structure, and are applied fundamentally to the same uses. They are traveling surfaces, and their wide range of modification is in direct relation to the media in which they are used. The one treads the solid ground, another the water, and another the yielding and elastic air. "But walking merges into swimming, and swimming into flying, by insensible gradations; and these modifications result from the fact that the earth affords a greater amount of support than the water, and the water than the air."

Most terrestrial quadrupeds can swim as well as walk, and some can fly. Many marine animals both walk and swim, and birds and insects walk, fly, and swim, indiscriminately. It is not surprising, therefore, that, between the typical foot, wing, and fin, innumerable modifications in structure and form occur; indeed, so graduated are they that it may be difficult to determine where one form ends and another begins.

In Fig. 1 we have several illustrations of the traveling surfaces of

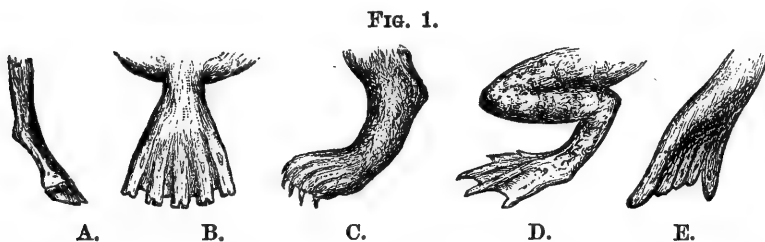

- A—Extreme form of compressed foot, as seen in the deer, ox, etc., adapted specially for land transit.  
 B—Extreme form of expanded foot, as seen in the ornithorhynchus, etc., adapted more particularly for swimming.  
 C—Intermediate form of foot, as seen in the otter.  
 D—Foot of frog. Here the foot is equally serviceable in and out of the water.  
 E—Foot of the seal, which opens and closes in the act of natation.

animals. The small feet of the quadruped, the webbed feet of the ornithorhynchus, the otter, the walrus, and the triton, indicate with certainty the media to which they are adapted, and perhaps in nothing is modification of structure and form to habits more apparent than in the locomotive appendages of animals. The webbed structure between the toes of animals which live partially on the land, and of some terrestrial animals, as the water-dog, is wonderfully significant.

The wing of the penguin, Fig. 2, is scarcely more than a flipper, and the same is true of the auk.

Sir John Lubbock describes a species of insect whose wings are

<sup>1</sup> "Animal Locomotion; or, Walking, Swimming, and Flying." By J. Bell Pettigrew, F. R. S. International Scientific Series. New York: D. Appleton & Co.

used as fins only. "Every variety of motion peculiar to land, air, and water-navigating animals, as such, is imitated by others which take to the elements in question, secondarily or at intervals." It is probably true, however, that no animal which lives indiscriminately in two media attains the highest development for traveling in or upon either. In such cases the maximum speed is not attained. Those animals, says the author, which swim the best, walk, as a rule, with difficulty, and *vice versa*, as the movements of the auk and the seal, in and out of water, amply testify. It is evident that all the supposed gaps between typical forms for locomotion are bridged by forms intermediate, and the author's position is fully sustained, that walking, swimming, and flying, are essentially the same.

FIG. 2.

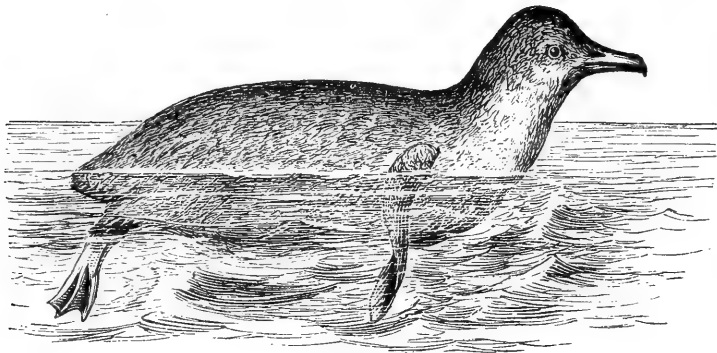

THE LITTLE PENGUIN, adapted exclusively for swimming and diving. In this quaint bird the wing forms a perfect screw, and is employed as such in swimming and diving.

Before entering upon the question of the movement and functions of specialized organs for locomotion, attention is invited to the interesting statement that, however wonderful and beautiful, in its way, the bony skeleton may be, it is after all only an adjunct to locomotion, and of motion in general—that all the really essential movements of an animal occur in the soft parts. "The osseous system is therefore to be regarded as secondary in importance to the muscular, of which it may be considered a differentiation. Instead of regarding the muscles as adapted to the bones, the bones ought to be regarded as adapted to the muscles. Bones have no power either of originating or perpetuating motion. This begins and terminates in the muscles."

The bones are the passive organs of locomotion, in the movement of which muscular force is expended. In land animals, as a rule, the bones are harder and more elastic than in aquatic species. The cartilaginous and spongy bones of many fishes would be ill suited to bear the strains and shocks of terrestrial progression.

The velocity with which a limb may be moved will depend upon the acuteness of the angles of its several bones. Hence the fleetness of many animals, in which the angles formed by the bones are acute. This is well shown in the skeleton of a deer, of which Fig. 3 is an ex-



cellent illustration. Here we have not only the sharp angles, but lever-like adjustment of the several bones.

From these arises the power possessed by many animals to bound or leap enormous distances. The kangaroo has been known to leap twenty feet. The jerboa, when pursued, will pass over nine feet at a bound, and repeats so rapidly that a swift horse can scarcely overtake it. The greyhound and the hare will pass over sixteen feet at a stride. Animals of great weight and moderate speed have nearly straight limbs. Those of the deer are more angular than those of a horse, and those in the wing of a bird more angular than those of the fleetest quadruped.

FIG. 3.

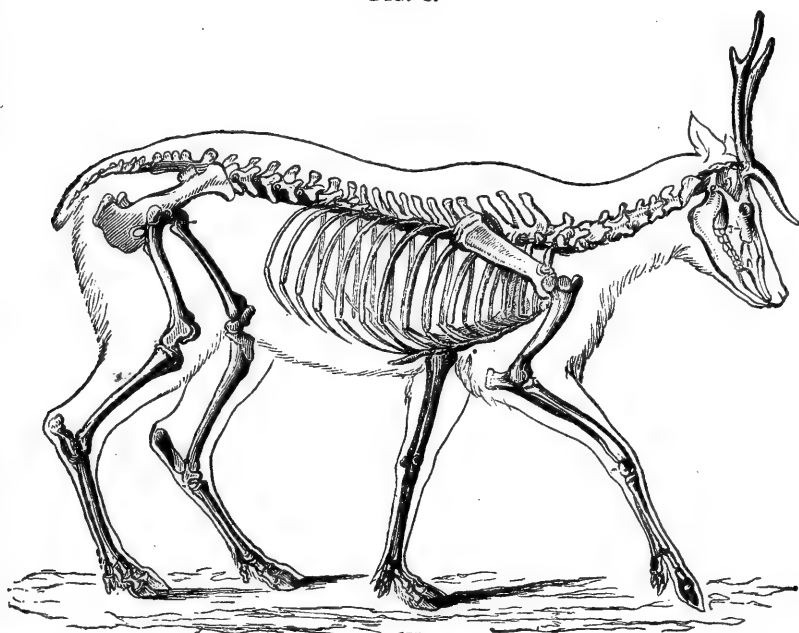

**SKELETON OF THE DEER** (after Pander and d'Alton). The bones in the extremities of this, the fleetest of quadrupeds, are inclined very obliquely toward each other, and toward the scapular and iliac bones. This arrangement increases the leverage of the muscular system, and confers great rapidity on the moving parts. It augments elasticity, diminishes shock, and indirectly begets continuity of movement.

The forms of joints which predominate in the animal kingdom are the hinge and the ball and socket. The latter gives to the extremities their extraordinary range of motion, and a power of rotation so indispensable, as we will see, to the effectiveness of all the organs of locomotion.

It has been shown that a spiral configuration occurs in the bones and joints of the wing of the bat and the bird, and in the extremities of most quadrupeds. "The bones of animals are, as a rule, twisted levers, and act after the manner of screws." Thus it is that their traveling surfaces in progression may be turned at almost any angle, getting from the resisting media in which they move as much propelling power as possible, with a minimum of slip or waste.

It is because the traveling surfaces of animals "are screws struct-

urally and functionally" that they can seize and let go the fulcra on which they act; particularly is this the case in the water and in the air, the form and movement being such that the greatest results are secured with the least expenditure of force. The muscles cover the bones, in layers or strata, and run longitudinally with them, and with each other, but also at every degree of obliquity. The spiral structure and movement of bones of animals have been carefully analyzed by Dr. Pettigrew, and some of his conclusions are illustrated in Fig. 4.

FIG. 4.

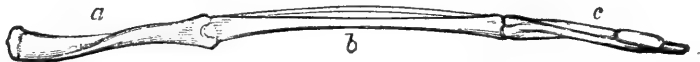

WING OF BIRD.—Shows how the bones of the arm (a), forearm (b), and hand (c), are twisted, and form a conical screw.

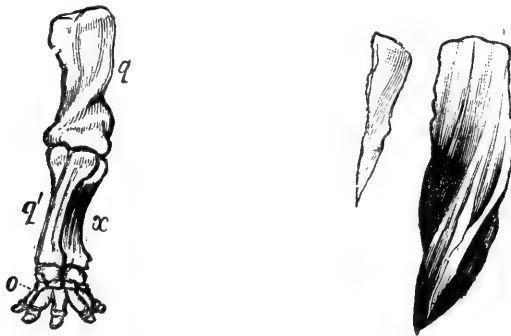

ANTERIOR EXTREMITY OF ELEPHANT.—Shows how the bones of the arm (q), forearm (q'x), and (o), are twisted to form an osseous screw. Cast or mould of the interior of the left ventricle of the heart of a deer. Shows that the left ventricular cavity is conical and spiral in its nature.

The *voluntary* muscles of the wing, he finds, are upon the same pattern as are those of the *involuntary* muscles of the heart. He compared the bones removed from the forelimb of a quadruped or bird, with a cast obtained from the cavity of a hollow muscle, the left ventricle of the heart of a mammal, and found that the bones and the cast are twisted upon themselves, and form elegant screws, the threads of which run in the same direction.

FIG. 5.



Diagram, showing the figure-of-8 or double-waved track produced by the alternating of the extremities in man in walking and running.

The movement of the limbs of a quadruped is in curves, which, continued, form a figure-of-8, or a series of them; a fact in progression first pointed out by Dr. Pettigrew. Quadrupeds, says the author, walk; fishes swim; insects, bats, and birds, fly by figure-of-8 move-

ments; and, in human locomotion, the same phenomenon is observed. The diagram, Fig. 5, shows the curved track made by man walking. The accuracy of this is easily verified by observation. As the limbs swing forward, they move in the arc of an ellipse; that is, in a slight curve outward, and with the arms form the double curves, as shown in the figure. In the movement of the horse, walking or trotting, the same phenomenon appears, as the figure shows.

FIG. 6.

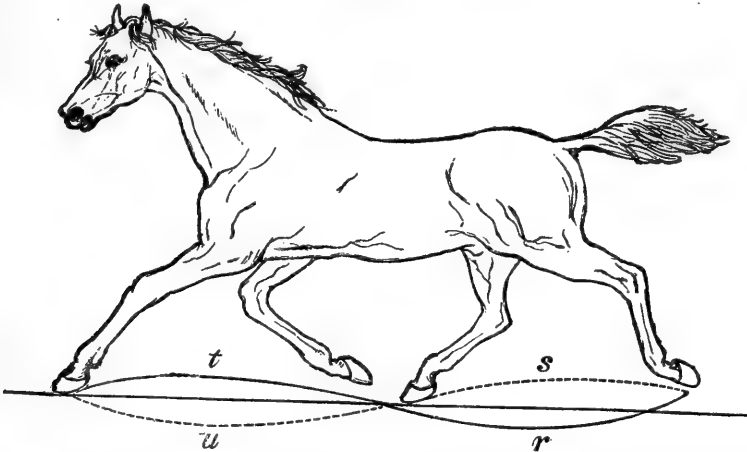

**HORSE IN THE ACT OF TROTING.**—In this, as in all the other paces, the body of the horse is levered forward by a diagonal twisting of the trunk and extremities, the extremities describing a figure-of-8 track (*s, u, r, t*).

The wings of birds, bats, and insects, describe similar curves. They are produced by the rotation of the wing, as it rises and falls, so that it twists, screw-like, on its long axis, one-half of the figure being formed in the ascent, the other in the descent of the wing.

FIG. 7.

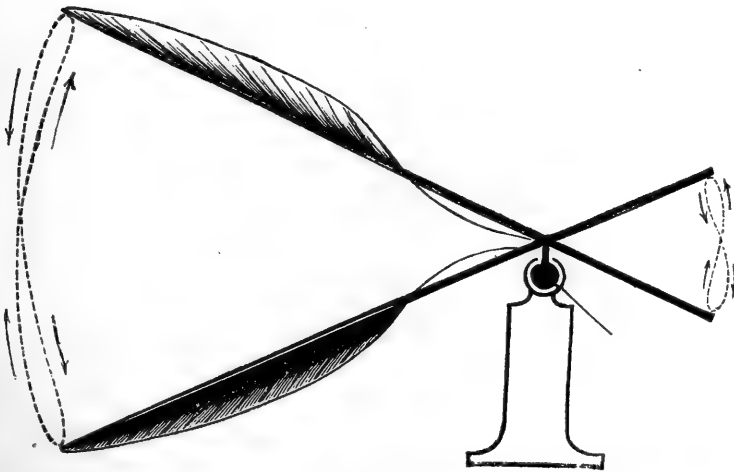

**IMITATION OF WING MOVEMENT BY A REED WITH FLEXIBLE SAIL MOVING ON A BALL-AND-SOCKET JOINT, SHOWING THE DOUBLE CURVES.**

The double curves or figure-of-8 lines which thus occur are not mere coincidences, nor in any sense accidental, but the expression of a

law of movement of vertebrated animals, and, from a most extended series of observations, Dr. Pettigrew concludes :

“That quadrupeds walk, and fishes swim, and insects, bats, and birds fly, by figure-of-8 movements.

“That the flipper of the sea-bear, the swimming wing of the penguin, and the wing of the insect, bat, and bird, are screws *structurally*, and resemble the blade of an ordinary screw-propeller.

“That those organs are screws *functionally*, from their twisting and untwisting, and from their rotating in the direction of their length, when they are made to oscillate.

“That they have a reciprocating action, and reverse their planes more or less completely at every stroke.

“That the wing describes a *figure-of-8 track* in space when the flying animal is artificially fixed.

“That the wing, when the flying animal is progressing at a high rate of speed in an horizontal direction, describes a *looped* and then a *wave track*, from the fact that the figure-of-8 is gradually *opened out and unraveled as the animal advances.*”

He constructed artificial fish-tails, fins, flippers, and wings—flexible and elastic—slightly twisted upon themselves, and applied them respectively to the water and air by a sculling or figure-of-8 motion. The curved surfaces and movements peculiar to the living organs were reproduced. The purely mechanical movement shown in this application of traveling structures to their environment scarcely admits of doubt.

Man is enabled to travel in two of the three great highways of Nature. He can progress upon the land, swim in the water, but fly he cannot; nor has he yet invented a means by which flying is possible. By his applications of natural laws he has “outraced the quadruped on the land and the fish in the sea,” and the conclusion from the analogy and nature of things is, that the “tramways of the air will yet be traversed by man’s ingenuity.”

A balloon floats, it does not fly. It floats because it is *lighter* than the air; a bird is enabled to fly because it is *heavier* than the air, and weight is an important element in all, but especially in aërial and land locomotion. It is that by which the extremities of animals seize and hold their position in the media in which they move. If a man were no heavier than the air, the movement of his limbs would avail him nothing. The earth is his fulcrum, as the air is that of the bird, and water that of the fish. Progression, therefore, implies gravity and the power of resistance, which gravity affords. A body which floats is carried along with the media in which it is; having lost its weight, it has lost its power of self-control. A man who cannot swim is at the mercy of the slightest current or wave, if in depth at which the lifting power of the water makes his foothold insecure.

A man standing still commences to progress by throwing his body

slightly forward. Some momentum is thus obtained, the limb being simultaneously advanced. "The throwing forward of the body may be said to inaugurate the movement of walking." The same occurs with a horse, but, if attached to a load, great impetus is attained by the body before either of the limbs is lifted. Momentum thus relieves muscular strain in the limbs and economizes force. How completely this principle is applied in swimming and flying will be presently noticed.

In ordinary walking of man or quadruped, the limbs swing forward without muscular effort. According to Prof. Weber, they swing by the force of gravity as a pendulum, and obey the same laws. If suspended they oscillate freely, and gravity brings them to a position of rest. How much the muscles are saved from exhaustion in ordinary locomotion, by gravity, becomes obvious when we attempt to overcome it by climbing or leaping. The foot being upon the ground, the limb rotates upon it as an axis, carrying the body forward and slightly elevating it, but the elevation is in the arc of a circle, and when the other foot reaches the ground the body is slightly lowered. Thus in progression the trunk continually rises and falls; it really undulates along a given line.

But other motions than those referred to are developed in the act of walking. The movements of the arms and feet are complementary; the right foot and left arm advance together, and *vice versa*. This begets a diagonal movement which produces oscillation or twisting of the trunk, which is excessive in awkward walkers. To repress this oscillatory swing is indispensable, if great velocity is to be attained. Trained runners flex their arms and hold them steadily at their greatest speed, and every school-boy does the same instinctively, without considering why the act is important. The swiftest-running birds have small wings; those of the ostrich are scarcely more than rudimental.

FIG. 8.

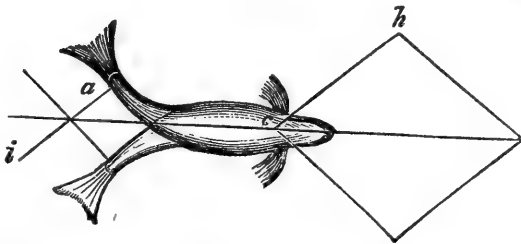

SWIMMING OF THE FISH—(After Borelli.)

The diagonal twist or movement referred to is expressed in a spiral wave of motion which traverses the trunk in the direction of its length. This motion is obvious in fishes in the act of swimming. It is a resultant of motions, which are in all vertebrates essentially the same. In the walking of a cat or panther, this wave of curvature is continuous along the spine. It is really a lateral undulation. We will

follow this curved motion in the swimming of aquatic animals. The illustration of Borelli (Fig. 8), shows only a single curve of the body.

Prof. Owen, commenting on this figure, says the tail of the animal moving from *a* to *i* causes the centre of gravity to move forward, and turns the head of the fish in the direction *c* to *h*. This implies but a single curve of the body, whereas there are two, the one complementary of the other, as is shown to be the case by Dr. Pettigrew. He says: "Observation and experiment have convinced me that when a fish swims it never throws its body into a single curve, as represented in Borelli's figure, but always in a double or figure-of-8 curve, as shown in Fig. 9.

FIG. 9.

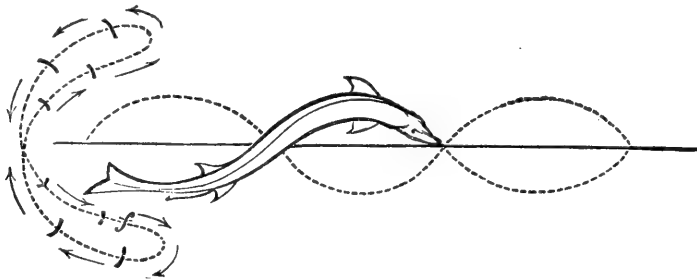

SWIMMING OF THE STURGEON.

In swimming, the body of the fish describes a waved track along a medial line. The two curves of the body act as fulcra for each other, as occurs in the movement of a snake, by its usual lateral undulations when swimming. In fishes and swimming reptiles of great length, there may occur more than two curves, as four, but never three, each curve having its complementary one. "The fish lashes its tail from side to side, and a figure-of-8 track is formed by the movement," both strokes propelling, but with unequal power during the course of the stroke. There is a feature in this movement which is equally obvious in the movement of the wings of birds in the air, that is, a current is formed, as the tail is carried to one side, against which the return-stroke is given; thus, as the author observes, "the tail may be said to work without slip, and to produce the precise kind of currents which afford it the greatest leverage."

And this is true, whether the swing of the tail in swimming is sideways, as with the salmon, or vertically, as occurs with the whale or the porpoise. The fins act as balancers of the body, but the equipoise is impaired if they are injured; and the removal of the tail, as Owen observes, destroys the power of locomotion.

The specific gravity of aquatic animals is nearly that of the water they inhabit, or is made so in many cases by the gaseous contents of their air-bladders. Nevertheless, momentum is an important element in swimming. It originates in the movement of the fins and tail, and not from throwing the body forward, as occurs in the initial movement of walking. The momentum and velocity attained by some



fishes are astonishingly great. A blow from the head of a sperm-whale may endanger a strong ship, and the sword of a sword-fish has been driven through the oak-planks of a vessel more than twelve inches in thickness.

FIG. 10.

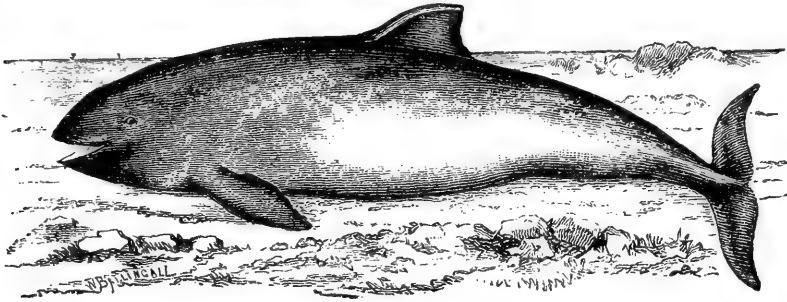

THE PORPOISE.—Here the tail is principally engaged in swimming, the anterior extremities being rudimentary, and resembling the pectoral fins of fishes.

When the flying-fish rises in the air, it is by the momentum it attains in the water by the lashing of its fins and tail. Fairly in the air, its wings give it support, and, in the opinion of Dr. Pettigrew, act as true pinions within certain limits, but are too small to sustain the creature indefinitely.

The transition from swimming to progression in the air is natural and easy. The method by which the flying-fish rises from the water is similar to that of the albatross, that prince of flying-birds, and, indeed, to perhaps all other birds, when in the act of taking flight upon the water. Momentum is obtained by rushing forward with both feet and wings. The albatross frequently goes in this way many rods before it is fairly launched upon the air. Then, with powerful strokes, it rises above the waves. Its expenditure of force is chiefly in rising, when, without further effort, except to screw and unscrew its pinions upon the wind, it floats facing the gale. For more than an hour it will sail with wings apparently motionless, and it seems most at rest when the winds are highest. In this case it is sustained by the momentum it attained, and the wonderful kite-like position and adjustment of its wings. But, it manifestly could not maintain its position in this way, if moving before the wind, or in a perfectly calm atmosphere. The wings must then be called into play to afford lifting as well as propelling power. The momentum must be supplied.

Birds rise from the ground most readily facing the wind, but usually run or leap, and the wings, by vigorous strokes, continue the impulse secured. With the first down-stroke of the wings the body is lifted, and some velocity attained; when the wings rise, the body falls somewhat, but is at the same time advancing. This rise and fall of the body in flying continue, and the body, in progressing, undulates above and below a given line. In the flight of birds with large wings and slow stroke, it is easily observed. The illustration, Fig. 11, shows

the positions of the wings of the gull in the course of a complete oscillation :

FIG. 11.

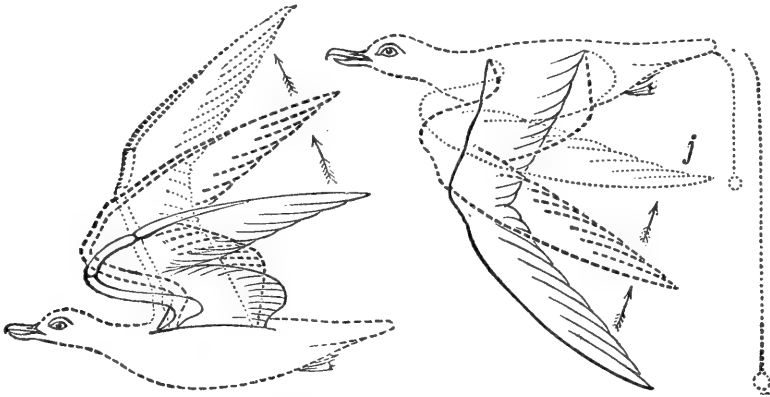

SHOWING THE MORE OR LESS PERPENDICULAR DIRECTION OF THE STROKE OF THE WING IN THE FLIGHT OF THE GULL.

When the down-stroke is completed the bird has been raised, but is lowered again when the wings have attained their maximum elevation. Thus it is seen how directly gravity aids in flight. The body is the weight ; the wings are long levers attached to it at one end ; the air is the fulcrum. Fig. 12 shows the undulatory track of a flying-bird :

FIG. 12.

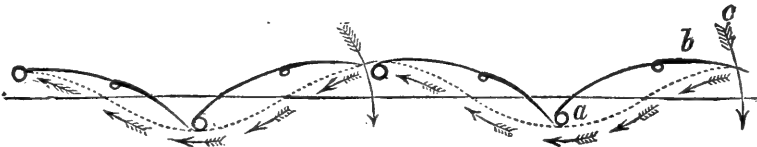

BIRD at *a* ; down-stroke of the wing, *b*, lifts the bird to *c*—the track of the bird being in direction of the arrows.

The instant the descent of the wing begins, the body moves upward and forward ; but it is shown by the author that some forward motion results also from the up-stroke. Certain it is that the upward movement must not counteract the other. There is no provision for

FIG. 13.

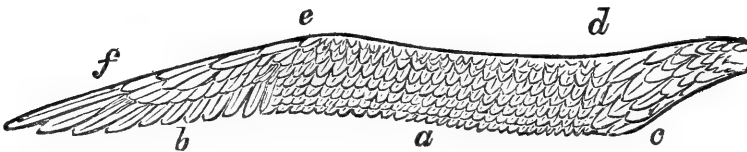

LEFT WING OF THE ALBATROSS.—*d, e, f*, Anterior or thick margin of pinion ; *b, a, c*, Posterior or thin margin, composed of the primary (*b*), secondary (*a*), and tertiary (*c*) feathers.

waste of energy. The form of the upper surface of the wing is convex, the under surface being concave. The value of this will be apparent, as the Duke of Argyle suggests, if we attempt to move the

concave or convex side of an umbrella against the wind; one side holds the air, the other discharges it. The wing of the albatross shows how completely the feathers are adjusted, on the upper side, to avoid any hold upon the air.

This arrangement, with the flexibility and screw-like motion of the wings of the gull, shown in Fig. 14, explains the exceedingly small resistance experienced in the upward movement, and also the forward impetus which it communicates.

FIG. 14.

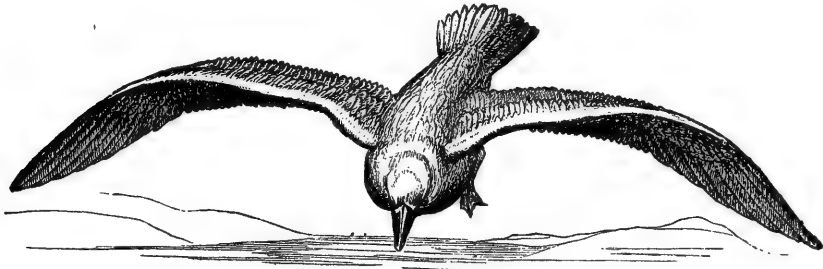

SHOWS THE TWISTED LEVERS OR SCREWS FORMED BY THE WINGS OF THE GULL.

It is in the down-stroke, or, as Dr. Pettigrew insists, in the beginning of the down-stroke, that force is chiefly expended. This movement is essentially a muscular act, and by this force alone no bird could sustain long-continued flight. The lark, whose flight is upward, soon descends to the earth. It lifts itself against gravity, simply by expenditure of vital force. But, the moment forward motion is attained, other forces relieve the strain upon the pinions, and their inclined surfaces convert gravity into a propelling power. It is obvious, however, that flight is attended with considerable muscular exertion. Migrating birds alight in unsuitable positions for rest, but the swallow will fly 1,000 miles in a single journey, and the condor attains an altitude of six miles.

The heron will strike the air 60 times in a minute, which, with 60 up-strokes, gives 120 movements, and this is continued through long

FIG. 15.



THE GRAY HERON IN FULL FLIGHT.

flights; and the same is true of many ducks and land-birds which strike the air with extreme and apparently exhausting rapidity. So swift are the motions of the wings of the humming-bird that they produce only a blurred spot before the eye.

That wings act as true kites, when in motion, is a familiar obser-

vation, but they are kites which continually change their surfaces and position in respect to the air, which artificial kites do not. An important difference between them is the rigidity of the one and the wonderful flexibility of the other. The kite rises as its oblique surface is pressed against the elastic air; the same is true of the wing. But the wing rotates, so that the proper obliquity of its parts is continually maintained; it rolls on and off the wind; it rotates not only throughout its length, but in each of its parts. The quills, which are convex, rotate, and present closed or oblique surfaces, which hold or discharge the air.

We have space for but one more of the numerous diagrams and figures which Dr. Pettigrew has prepared, illustrating the phenomena of flight. Fig. 16 is of the extended wing of a partridge, seen from beneath and from behind.

FIG. 16.



CURVES IN THE WING OF A PARTRIDGE IN FLIGHT.

The wings, when flexed and extended in flight, assume curved surfaces, which change at each instant and carve the air, as does the tail of the fish the water, into complex wave-lines; and such is the structure of the wing that these results are inevitable when it is put in motion. "The muscles, bones, ligaments, and feathers, are so adjusted with reference to each other that, if the wing is moved at all, it must move in the proper direction." The bird no more thinks of its motions in flying than we do of ours in walking; the actions are mechanical and instinctive. An opinion long prevailed that heated air in the hollow bones of the bird gave it buoyancy and power of flight. This is shown to be a fallacy.

Three principal forces are expressed in flight: muscular and elastic force of the wing, weight of the body, and recoil of the air. By the mechanical structure of the wing, these forces act, react, and combine. Thus birds traverse the aerial ocean; the wild-goose drives his train along invisible tracks; the albatross and petrel are at home in the gale, undisturbed by its clamor; and the condor, with easy motion, treads with his pinions the elastic floors of the upper air.

The more rapid the strokes of the wing the greater the achievement. Not so with one of the most ingenious of human contrivances for progression. The screw, if urged beyond a certain velocity, holds and carries with it the water, and its propelling power is lost. It wants the flexibility of the wing and the fin—the adaptation is not complete.

## REPLIES TO THE QUARTERLY REVIEWERS.

BY HERBERT SPENCER.

WITH the concluding paragraph of the previous article replying to criticisms I had hoped to end, for a long time, all controversial writing. But, while it was in the printer's hands, two criticisms, more elaborate than those dealt with above, made their appearance; and, now that the postponed publication of this latter half of the article affords the opportunity, I cannot, without risking misinterpretations, leave these criticisms unnoticed.

Especially do I feel called upon by courtesy to make some response to one who, in the *Quarterly Review*, for October, has dealt with me in a spirit which, though largely antagonistic, is not wholly unsympathetic, and who manifestly aims to estimate justly the views he opposes. In the space at my disposal, I cannot of course follow him through all the objections he has urged. I must content myself with brief comments on the two propositions he undertakes to establish. His enunciation of these runs as follows:

"We would especially direct attention to two points, to both of which we are confident objections may be made; and, although Mr. Spencer has himself doubtless considered such objections (and they may well have struck many of his readers also), we nevertheless do not observe that he has anywhere noticed or provided for them.

"The two points we select are:

"1. *That his system involves the denial of all truth.*

"2. *That it is radically and necessarily opposed to all sound principles of morals.*"

On this passage, ending in these two startling assertions, let me first remark that I am wholly without this consciousness the reviewer ascribes to me. Remembering that I have expended some little labor in developing what I conceive to be a system of truths, I am somewhat surprised by the supposition that "the denial of all truth" is an implication which I am "doubtless" aware may be alleged against this system. Remembering, too, that by its programme this system is shown to close with two volumes on "The Principles of Morality," the statement that it is "necessarily opposed to all sound principles of morals" naturally astonishes me, and still more the statement that I am doubtless conscious it may be so regarded. Saying thus much by way of repudiating that latent skepticism attributed to me by the reviewer, I proceed to consider what he says in proof of these propositions.

On those seeming incongruities of Transfigured Realism commented on by him, I need say no more than I have already said in reply to Mr. Sidgwick, by whom also they have been alleged. I

will limit myself to the corollary he draws from the doctrine of the Relativity of Knowledge, as held by me. Rightly pointing out that I hold this in common with "Messrs. Mill, Lewes, Bain, and Huxley," but not adding, as he should have done, that I hold it in common with Hamilton, Mansel, and the long list of predecessors through whom Hamilton traced it, the reviewer proceeds to infer from this doctrine of relativity that no absolute truth of any kind can be asserted—not even the absolute truth of the doctrine of relativity itself. And then he leaves it to be supposed by his reader that this inference tells especially against the system he is criticising. If, however, the reviewer's inference is valid, this "denial of all truth" must be charged against the doctrines of thinkers called orthodox, as well as against the doctrines of those many philosophers, from Aristotle down to Kant, who have said the same thing. But now I go further, and reply that, against that form of the doctrine of relativity held by me, this allegation cannot be made with the same effect as it can against preceding forms of the doctrine. For I diverge from other relativists in asserting that the existence of a non-relative is not only a positive deliverance of consciousness, but a deliverance transcending in certainty all others whatever, and is one without which the doctrine of relativity cannot be framed in thought. I have urged that, "unless a real Non-relative or Absolute be postulated, the Relative itself becomes absolute, and so brings the argument to a contradiction;"<sup>1</sup> and elsewhere I have described this consciousness of a Non-relative manifested to us through the Relative as "deeper than demonstration—deeper even than definite cognition—deep as the very nature of mind;"<sup>2</sup> which seems to me to be saying as emphatically as possible that, while all other truths may be held as relative, this truth must be held as absolute. Yet, strangely enough, though contending thus against the pure relativists, and holding with the reviewer, that "every asserter of such a (purely-relative) philosophy must be in the position of a man who saws across the branch of a tree on which he actually sits, at a point between himself and the trunk,"<sup>3</sup> I am singled out by him as though this were my own predicament. So far, then, from admitting that the view I hold "involves the denial of all truth," I assert that, having at the outset posited the coexistence of subject and object as a deliverance of consciousness which precedes all reasoning<sup>4</sup>—having subsequently shown, analytically, that this postulate is in every way verified,<sup>5</sup> and that in its absence the proof of relativity is impossible—my view is distinguished by an exactly-opposite trait.

The justification of his second proposition the reviewer commences by saying that "in the first place the process of Evolution, as understood by Mr. Spencer, compels him to be at one with Mr. Darwin in

<sup>1</sup> "First Principles," § 26.

<sup>2</sup> *Ibid.*, § 62.

<sup>3</sup> Compare "Principles of Psychology," §§ 88, 95, 391, 401, 406.

<sup>4</sup> "First Principles," §§ 39, 45.

<sup>5</sup> "Principles of Psychology," part vii.



his denial of the existence of any fundamental and essential distinction between Duty and Pleasure." Following this by a statement respecting the genesis of moral sentiments as understood by me (which is extremely unlike the one I have given in the "Principles of Psychology" (§ 215, §§ 503-512, and §§ 524-532), the reviewer goes on to say that "we yield with much reluctance to the necessity of affirming that Mr. Spencer gives no evidence of ever having acquired a knowledge of the meaning of the term 'morality,' according to the true sense of the word."

Just noting that, as shown by the context, the assertion thus made is made against all those who hold the Doctrine of Evolution in its unqualified form, I reply that, in so far as it concerns me, it is one the reviewer would scarcely have made had he more carefully examined the evidence—not limiting himself to those works of mine named at the head of his article. And I cannot but think that, had the spirit of fairness, which he evidently strives to maintain, been fully awake when these passages were written, he would have seen that, before making so serious an allegation, wider inquiry was needful. If he had simply said that, given the doctrine of mental evolution as held by me, he failed to see how moral principles were to be established, I should not have objected; provided he had also said that I believe they can be established, and had pointed out what I hold to be their bases. As it is, however, he has so presented his own inference from my premises as to make it seem an inference which I also must draw from my premises. Quite a different and much more secure foundation for moral principles is alleged by me than that afforded by moral sentiments and conceptions, which he refers to as though they formed the sole basis of the ethical conclusions I hold. While the reviewer contends that "Mr. Spencer's moral system is even yet more profoundly defective, as it denies any objective distinction between right and wrong in any being, whether men are or are not responsible for their actions," I contend, contrariwise, that it is distinguished from other moral systems by asserting the objectivity of the distinction, and by endeavoring to show that the subjective distinction is derived from the objective distinction. In my first work, "Social Statics," published twenty-three years ago, the essential thesis is that, apart from their warrant as alleged Divine injunctions, and apart from their authority as moral intuitions, the principles of justice are primarily deducible from the laws of life, as carried on under social conditions. I argued throughout that these principles so derived have a supreme authority, to which considerations of immediate expediency must yield, and I was for this reason classed by Mr. Mill as an anti-utilitarian. More recently, in a letter drawn from me by this misapprehension of Mr. Mill, and afterward published by Prof. Bain in his "Mental and Moral Science," I have restated this position. Already, in an explanatory article entitled "Morals and Moral Sentiments,"

published in this *Review* for April, 1871, I have quoted passages from that letter; and here, considering the gravity of the assertions made by the *Quarterly* reviewer, I hope to be excused for re quoting them:

“Morality, properly so called—the science of right conduct—has for its object to determine *how* and *why* certain modes of conduct are detrimental, and certain other modes beneficial. These good and bad results cannot be accidental, but must be necessary consequences of the constitution of things; and I conceive it to be the business of Moral Science to deduce, from the laws of life and the conditions of existence, what kinds of action necessarily tend to produce happiness, and what kinds to produce unhappiness. Having done this, its deductions are to be recognized as laws of conduct, and are to be conformed to irrespective of a direct estimation of happiness or misery.”

“If it is true that pure rectitude prescribes a system of things far too good for men as they are, it is not less true that mere expediency does not of itself tend to establish a system of things any better than that which exists. While absolute morality owes to expediency the checks which prevent it from rushing into Utopian absurdities, expediency is indebted to absolute morality for all stimulus to improvement. Granted that we are chiefly interested in ascertaining what is *relatively right*, it still follows that we must first consider what is *absolutely right*; since the one conception presupposes the other.”

And the comment I then made on these passages I may make now, that “I do not see how there could well be a more emphatic assertion that there exists a primary basis of morals independent of, and in a sense antecedent to, that which is furnished by experiences of utility, and consequently independent of, and in a sense antecedent to, those moral sentiments which I conceive to be generated by such experiences.” I will only add that, had my beliefs been directly opposite to those I have enunciated, the reviewer might, I think, have found good reasons for his assertion. If, instead of demurring to the doctrine that “greatest happiness should be the *immediate* aim of man,”<sup>1</sup> I had indorsed that doctrine—if, instead of explaining and justifying “a belief in the special sacredness of these highest principles, and a sense of the supreme authority of the altruistic sentiments answering to them,”<sup>2</sup> I had denied the sacredness and the supreme authority—if, instead of saying of the wise man that “the highest truth he sees he will fearlessly utter, knowing that, let what may come of it, he is thus playing his right part in the world,”<sup>3</sup> I had said that the wise man will *not* do this—the reviewer might with some truth have described me as not understanding “the term ‘morality’ according to the true sense of the word.” And he might then have inferred that the Doctrine of Evolution, as I hold it, implies denial of the “distinction between Duty and Pleasure.” But, as it is, I think the evidence will not generally be held to warrant his assertion.

I quite agree with the reviewer that the prevalence of a philosophy

<sup>1</sup> “Social Statics,” chapter iii.

<sup>2</sup> “Principles of Psychology,” § 531.

<sup>3</sup> “First Principles,” § 34.

“is no mere question of speculative interest, but is one of the highest practical importance.” I join him, too, in the belief that “calamitous social and political changes” may be the outcome of a mistaken philosophy. Moreover, writing as he does under the conviction that there can be no standard of right and wrong save one derived from a Revelation interpreted by an Infallible Authority, I can conceive the alarm with which he regards so radically-opposed a system. Though I could have wished that the sense of justice he generally displays had prevented him from ignoring the evidence I have above given, I can understand how, from his point of view, the Doctrine of Evolution, as I understand it, “seems absolutely fatal to every germ of morality,” and “entirely negatives every form of religion.” But I am unable to understand that modified doctrine of Evolution which the reviewer proposes as an alternative. For, little as the reader would anticipate it after these expressions of profound dissent, the reviewer displays such an amount of agreement as to suggest that the system he is criticising might be converted, “rapidly and without violence, into an ‘allotropic state,’ in which its conspicuous characters would be startlingly diverse from those that it exhibits at present.” May I, using a different figure, suggest a different transformation, having a subjective instead of an objective character? As, in a stereoscope, the two views, representing diverse aspects, often yield at first a jumble of conflicting impressions, but after a time suddenly combine into a single whole which stands out quite clearly, so, may it not be that the seemingly-inconsistent Idealism and Realism dwelt on by the reviewer, as well as the other seemingly-fundamental incongruities he is struck by, will, under more persistent contemplation, unite as complementary sides of the same thing?

My excuse, for devoting so much space to a criticism of so entirely different a kind as that contained in the *British Quarterly Review* for October, must be that, under the circumstances, I cannot let it pass unnoticed without seeming to admit its validity.

Saying that my books should be dealt with by specialists, and tacitly announcing himself as an expert in Physics, the reviewer takes me to task both for errors in the statement of physical principles and for erroneous reasoning in physics. That he discovers no mistakes I do not say. It would be marvelous if, in such a multitude of propositions, averaging a dozen per page, I had made all criticism-proof. Several are inadvertencies which I should have been obliged to the reviewer for pointing out as such, but which he prefers to instance as proving my ignorance. In other cases, taking advantage of an imperfection of statement, he proceeds to instruct me about matters which either the context, or passages in the same volume, show to be quite familiar to me. Here is a sample of his criticisms belonging to this class:

“Nor should we counsel a man to venture upon physical speculations who converts the proposition ‘*heat is insensible motion*’ into ‘*insensible motion is heat*,’ and hence concludes that when a force is applied to a mass so large that no motion is seen to result from it, or when, as in the case of sound, motion gets so dispersed that it becomes insensible, it turns to heat.”

Respecting the first of the two statements contained in this sentence, I will observe that the reader, if not misled by the quotation-marks into the supposition that I have made, in so many words, the assertion that “insensible motion is heat,” will at any rate infer that this assertion is distinctly involved in the passage named. And he will infer that the reviewer would never have charged me with such an absurd belief, if there was before him evidence proving that I have no such belief. What will the reader say, then, when he learns, not simply that there is no such statement, and not simply that on the page referred to, which I have ascertained to be the one intended, there is no such implication visible, even to an expert (and I have put the question to one), but when he further learns that, in other passages, the fact that heat is the one only of modes of insensible motion is distinctly stated (see “First Principles,” §§ 66, 68, 171), and when he learns that elsewhere I have specified the several forms of insensible motion? If the reviewer, who looks so diligently for flaws as to search an essay in a volume he is not reviewing to find one term of an incongruity, had sought with equal diligence to learn what I thought about insensible motion, he would have found in the “Classification of the Sciences,” Table II., that insensible motion is described by me as having the forms of heat, light, electricity, magnetism. Even had there been, in the place he names, an unquestionable implication of the belief which he ascribes to me, fairness might have led him to regard it as an oversight, when he found it at variance with statements I have elsewhere made. What, then, is to be thought of him when, in the place named, no such belief is manifest, either to an ordinary reader or a specially-instructed reader?

No less significant is the state of mind betrayed in the second clause of the reviewer’s sentence. By representing me as saying that, when the motion constituting sound “gets so dispersed that it becomes insensible, it turns to heat,” does he intend to represent me as thinking that, when sound-undulations become too weak to be audible, they become heat-undulations? If so, I reply that the passage he refers to has no such meaning. Does he then allege that some part of the force diffused in sound-waves is expended in generating electricity, by the friction of heterogeneous substances (which, however, eventually lapses from this special form of molecular motion in that general form constituting heat), and that I ought to have thus qualified my statement? If so, he would have had me commit a piece of scientific pedantry hindering the argument. If he does not mean either of these things, what does he mean? Does he contest the truth of the

hypothesis which enabled Laplace to correct Newton's estimate of the velocity of sound—the hypothesis that heat is evolved by the compression each sound-wave produces in the air? Does he deny that the heat so generated is at the expense of so much wave-motion lost? Does he question the inference that some of the motion embodied in each wave is from instant to instant dissipated, partly in this way and partly in the heat evolved by fluid friction? Can he show any reason for doubting that, when the sound-waves have become too feeble to affect our senses, their motion still continues to undergo this transformation and diminution until it is all lost? If not, why does he implicitly deny that the molar motion constituting sound eventually disappears in producing the molecular motion constituting heat?<sup>1</sup>

I will dwell no longer on the exclusively-personal questions raised by the reviewer's statements, but, leaving the reader to judge of the rest of my "stupendous mistakes" by the one I have dealt with, I will turn to a question worthy to occupy some space, as having an impersonal interest—the question, namely, respecting the nature of the warrant we have for asserting ultimate physical truths. The contempt which, as a physicist, the reviewer expresses for the metaphysical exploration of physical ideas, I will pass over with the remark that every physical question, probed to the bottom, ends in a metaphysical one, and that I should have thought the controversy now going on among chemists, respecting the legitimacy of the atomic hypothesis, might have shown him as much. On his erroneous statement that I use the phrase "Persistence of Force" as an equivalent for the now-generally-accepted phrase "Conservation of Energy," I will observe only that, had he not been in so great a hurry to find inconsistencies, he would have seen why, for the purposes of my argument, I intentionally use the word Force: Force being the generic word, including both that species known as Energy, and that species by which Matter occupies space and maintains its integrity—a species which, whatever may be its relation to Energy, and however clearly recognized as a

<sup>1</sup> Only after the foregoing paragraphs were written, did the remark of a distinguished friend show me how certain words were misconstrued by the reviewer in a way that had never occurred to me as possible. In the passage referred to, I have said that sound-waves "finally die away in generating thermal undulations that radiate into space;" meaning, of course, that the force embodied in the sound-waves is finally *exhausted* in generating thermal undulations. In common speech, the dying away of a prolonged sound, as that of a church-bell, includes its gradual diminution as well as its final cessation. But, rather than suppose I gave to the words this ordinary meaning, the reviewer supposes me to believe, not simply that the *longitudinal* waves of air can pass, *without discontinuity*, into the *transverse* waves of ether, but he also debits me with the belief that the one order of waves, having lengths measurable in feet, and rates expressed in hundreds per second, can *by mere enfeeblement* pass into the other order of waves, having lengths of some fifty thousand to the inch, and rates expressed in many billions per second! Why he preferred so to interpret my words, and that, too, in the face of contrary implications elsewhere (instance § 100), will, however, be manifest to every one who reads his criticisms.

necessary *datum* by the theory of Energy, is not otherwise considered in that theory. I will confine myself to the proposition, disputed at great length by the reviewer, that our cognition of the Persistence of Force is *a priori*. He relies much on the authority of Prof. Tait, whom he twice quotes to the effect that—

“ Natural philosophy is an experimental, and not an intuitive science. No *a priori* reasoning can conduct us demonstratively to a single physical truth.”

Were I to take an hypercritical attitude, I might dwell on the fact that Prof. Tait leaves the extent of his proposition somewhat doubtful, by speaking of “ Natural philosophy ” as *one* science. Were I to follow further the reviewer’s example, I might point out that “ Natural philosophy,” in that Newtonian acceptance adopted by Prof. Tait, includes Astronomy; and, going on to ask what astronomical “ experiments ” those are which conduct us to astronomical truths, I might then “ counsel ” the reviewer not to depend on the authority of one who (to use the reviewer’s polite language) “ blunders ” by confounding experiment and observation. I will not, however, thus infer from Prof. Tait’s imperfection of statement that he is unaware of the difference between the two; and shall rate his authority as of no less value than I should had he been more accurate in his expression. Respecting that authority I shall simply remark that, if the question had to be settled by the authority of any physicist, the authority of one who is diametrically opposed to Prof. Tait on this point, and who has been specially honored, both by the Royal Society and by the French Institute, might well counterweigh his, if not outweigh it. I am not aware, however, that the question is one in Physics. It seems to me a question respecting the nature of proof. And, without doubting Prof. Tait’s competence in Logic and Psychology, I should decline to abide by his judgment on such a question, even were there no opposite judgment given by a physicist, certainly of not less eminence.

Authority aside, however, let us discuss the matter on its merits. In the “ Treatise on Natural Philosophy,” by Profs. Thomson and Tait, § 243, I read that, “ as we shall show in our chapter on ‘ Experience,’ physical axioms are axiomatic to those only who have sufficient knowledge of the action of physical causes to enable them to see at once their necessary truth.” In this I agree entirely. It is in Physics, as it is in Mathematics, that, before necessary truths can be grasped, there must be gained, by individual experience, such familiarity with the elements of the thoughts to be framed that propositions about those elements may be mentally represented with distinctness. Tell a child that things which are equal to the same thing are equal to one another, and the child, lacking a sufficiently abstract notion of equality, and lacking, too, the needful practice in comparing relations, will fail to grasp the axiom. Similarly, a rustic, never having thought much about forces and their results, cannot form a definite conception



answering to the axiom that action and reaction are equal and opposite. In the last case, as in the first, ideas of the terms and their relations require to be made, by practice in thinking, so vivid that the involved truths may be mentally seen. But when the individual experiences have been multiplied enough to produce distinctness in the representations of the elements dealt with, then, in the one case, as in the other, those mental forms, generated by ancestral experiences, cannot be occupied by the elements of one of these ultimate truths without perception of its necessity. If Prof. Tait does not admit this, what does he mean by speaking of "physical *axioms*," and by saying that the cultured are enabled "to see *at once* their *necessary* truth?"

Again, if there are no physical truths which must be classed as *a priori*, I ask why Prof. Tait joins Sir W. Thomson in accepting, as bases for Physics, Newton's Laws of Motion? Though Newton gives illustrations of prolonged motion in bodies that are little resisted, he gives no *proof* that a body in motion will continue moving, if uninterfered with, in the same direction at the same velocity; nor, on turning to the enunciation of this law, quoted in the above-named work, do I find that Prof. Tait does more than exemplify it by facts which can themselves be asserted only by taking the law for granted. Does Prof. Tait deny that the first law of motion is a physical truth? If so, what does he call it? Does he admit it to be a physical truth, and, denying that it is *a priori*, assert that it is established *a posteriori*—that is, by conscious induction from observation and experiment? If so, what is the inductive reasoning which can establish it? Let us glance at the several conceivable arguments which we must suppose him to rely on.

A body set in motion soon ceases to move if it encounters much friction, or much resistance from other bodies struck. If less of its energy is expended in moving, or otherwise affecting, other bodies, or in overcoming friction, its motion continues longer. And it continues longest when, as over smooth ice, it meets with the smallest amount of obstruction from other matter. May we then, proceeding by the method of concomitant variations, infer that were it wholly unobstructed its motion would continue undiminished? If so, we assume that the diminution of its motion observed in experience is proportionate to the amount of energy abstracted from it in producing other motion, either molar or molecular. We assume that no variation has taken place in its rate, save that caused by deductions in giving motion to other matter; for, if its motion be supposed to have otherwise varied, the conclusion, that the differences in the distances traveled result from differences in the obstructions met with, is vitiated. Thus the truth to be established is already taken for granted in the premises. Nor is the question begged in this way only. In every case where it is remarked that a body stops the sooner, the more it is obstructed by other bodies or media, the law of inertia is assumed to hold in the obstructing bodies or media. The very conception of greater or less

retardation so caused, implies the belief that there can be no retardations without proportionate retarding causes; which is itself the assumption otherwise expressed in the first law of motion.

Again, let us suppose that, instead of inexact observations made on the movements that occur in daily experience, we make exact experiments on movements specially arranged to yield measured results; what is the postulate underlying every experiment? Uniform velocity is defined as motion through equal spaces in equal times. How do we measure equal times? By an instrument which can be inferred to mark equal times only if the oscillations of the pendulum are isochronous; which they can be proved to be only if the first and second laws of motion are granted. That is to say, the proposed experimental proof of the first law assumes not only the truth of the first law, but of that which Prof. Tait agrees with Newton in regarding as a second law. Is it said that the ultimate time-measure referred to is the motion of the Earth round its axis, through equal angles in equal times? Then, the obvious rejoinder is, that the assertion of this similarly involves an assertion of the truth to be proved; since the undiminished rotatory movement of the Earth is itself a corollary upon the first law of motion. Is it alleged that this axial movement of the Earth through equal angles in equal times is ascertainable by reference to the stars? I answer, that a developed system of Astronomy, leading through complex reasonings to the conclusion that the Earth rotates, is, in that case, supposed to be needful before there can be established a law of motion which this system of Astronomy itself postulates. For, even should it be said that the Newtonian theory of the Solar System is not necessarily presupposed, but only the Copernican, still the proof of this assumes that a body at rest (a star being taken as such) will continue at rest; which is a part of the first law of motion, regarded by Newton as not more self-evident than the remaining part.

Not a little remarkable, indeed, is the oversight made by Prof. Tait, in asserting that "no *a priori* reasoning can conduct us demonstratively to a single physical truth," when he has before him the fact that the system of physical truths constituting Newton's "Principia," which he has joined Sir William Thomson in editing, is established by *a priori* reasoning. That there can be no change without a cause, or, in the words of Mayer, that "a force cannot become nothing, and just as little can a force be produced from nothing," is that ultimate dictum of consciousness on which all physical science rests. It is involved alike in the assertion that a body at rest will continue at rest, in the assertion that a body in motion must continue to move at the same velocity in the same line if no force acts upon it, and in the assertion that any divergent motion given to it must be proportionate to the deflecting force; and it is also involved in the axiom that action and reaction are equal and opposite.

The reviewer's doctrine, in support of which he cites against me

the authority of Prof. Tait, illustrates in Physics that same error of the inductive philosophy which, in Metaphysics, I have pointed out elsewhere ("Principles of Psychology," Part VII.). It is a doctrine implying that we can go on forever asking the proof of the proof, without finally coming to any deepest cognition which is unproved and unprovable. That this is an untenable doctrine I need not say more to show. Nor, indeed, would saying more to show it be likely to have any effect, in so far at least as the reviewer is concerned; seeing that he thinks I am "ignorant of the very nature of the principles" of which I am speaking, and seeing that my notions of scientific reasoning "remind" him "of the Ptolemists," who argued that the heavenly bodies must move in circles because the circle is the most perfect figure.<sup>1</sup>

Not to try the reader's patience further, I will end by pointing out that, even were the reviewer's criticisms all valid, they would leave unshaken the system he contends against. Though one of his sentences (page 480) raises the expectation that he is about to assault, and greatly to damage, the fabric of propositions contained in the second part of "First Principles," yet all those propositions which constitute the fabric he leaves not only uninjured but even untouched, contenting himself with trying to show (with what success we have seen) that the fundamental one is an *a posteriori* truth, and not an *a priori* truth. Against the general Doctrine of Evolution, considered as an induction from all concrete phenomena, he utters not a word; nor does he utter a word to disprove any one of those laws of the redistribution of matter and motion by which the process of Evolution is deductively interpreted. Respecting the law of the Instability of the Homogeneous, he says no more than to quarrel with one of the illustrations. He makes no criticism on the law of the Multiplication of Effects. The law of Segregation he does not even mention. Nor does he mention the law of Equilibration. Further, he urges nothing against the statement that these general laws are severally deducible from the ultimate law of the Persistence of Force. Lastly, he does not deny the Persistence of Force, but only differs respecting the na-

<sup>1</sup> Other examples of these amenities of controversy, in which I decline to imitate my reviewer, have already been given. What occasions he supplies me for imitation, were I minded to take advantage of them, an instance will show. Pointing out an implication of certain reasonings of mine, he suggests that it is too absurd even for me to avow explicitly, saying: "We scarcely think that even Mr. Spencer will venture to claim as a datum of consciousness the Second Law of Motion, with its attendant complexities of component velocities," etc. Now, any one who turns to Newton's "Principia" will find that to the enunciation of the Second Law of Motion nothing whatever is appended but an amplified restatement—there is not even an illustration, much less a proof. And from this law, this axiom, this immediate intuition or "datum of consciousness," Newton proceeds forthwith to draw those corollaries respecting the composition of forces which underlie all dynamics. What, then, must be thought of Newton, who explicitly assumes that which the reviewer thinks it absurd to assume implicitly?

ture of our warrant for asserting it. Beyond pointing out here a cracked brick, and there a coin set askew, he merely makes a futile attempt to show that the foundation is not natural rock, but concrete.

From his objections I may, indeed, derive much satisfaction. That a competent critic, obviously anxious to do all the mischief he can, and not over-scrupulous about the means he uses, has done so little, may be taken as evidence that the fabric of conclusions attacked will not be readily overthrown.



## PHYSIOLOGY OF THE PASSIONS.

By FERNAND PAPILLON.

TRANSLATED FROM THE FRENCH, BY J. FITZGERALD, A. M.

IF there is to-day a fact demonstrated by reason reflexly contemplating itself no less than by attentive observation of the entire development of human knowledge, it is the close interdependence of all natural forces and operations—a solidarity so firmly knit that it is impossible to study any one point of detail without reference to the sum total of the phenomena. The sciences, long kept apart from one another, now all tend to come together, to fuse into one another, for the explication of facts. It is the exigencies of the science of man that, above all, have determined this irresistible attraction, this systematic confluence of branches of knowledge the most diverse toward one centre, where they attain their full value and their full significance. Man brings together within himself, as Buffon says, all the powers of Nature: he is the centre to which all things are referred—a world in miniature; no amount of analysis can come amiss, if we are to resolve the endless complexity of this so multiple being; and we need all the light we can get, in order to illumine the darkness that surrounds this mysterious creature. If, as Leibnitz thinks, one single monad—an imperceptible atom—is a mirror of the total beauty of the universe, how much more truly may this be said of that singular and diversified assemblage of monads, man! Surely it would ill become us to disparage the psychologist, whose study has been to get at a knowledge of man solely by observation of the phenomena of consciousness; or the physiologist, who has attempted to find an explication solely in organic phenomena. Both of these have, with much toil, broken the ground and prepared a field where investigation may henceforth bear fruit; but, precisely because the soil is now ready, it is to be hoped that the controversies and antagonisms of the past will give way to a good understanding, more conducive to a true knowledge of man's nature; and that inquiry, instead of diverging

and so losing itself, shall be regulated and coördinated to the attainment of one end.

These reflections are addressed neither to those who imagine that psychology has done all its work already, nor to those who think that work never can be done; we submit them to those who, following attentively the double movement of physiology and of psychology, find that, at least, the progress made by each of these sciences is correlative with that made by the other, and inseparable from it. Philosophers, whose position and whose previous inquiries seemed very unlikely to invite them to the study of physical man, now devote themselves to this study with enlightened ardor. Experimenters, whose reputation and whose habits might appear very unapt to incline them toward the study of moral man, now pursue that study with conscientious diligence. The result is, a profounder and more precise science of the relations between the physical and the moral—a science that is full of revelations and surprises.

## I.

The ancients had a theory with regard to the passions which, at bottom, differs not much from that countenanced in these later times, by experimental physiology and pathology. They erred with regard to the rôle of the humors and the physiological mechanism in the production of passional phenomena; but they had closely observed, and, with rare precision, defined the influence exerted by these on the viscera of the abdominal region. Their poetry and their medical writings are full of expressions which show how ancient is the knowledge of this relation between the soul's sentiments and the movements of heart, lungs, stomach, and liver.<sup>1</sup> The ancients even went so far as to localize the passions in the viscera; and their theory on this subject is expressed in the aphorism, "*Splene rident, felle irascunt, jecore amant, pulmone jactantur,*" where the *spleen*, the *gall-bladder*, the *liver*, and the *lungs*, are represented as the seat respectively of mirth, anger, love, and vainglory. The physiology of the passions, so far as it could be and was studied by the authors of ancient times, was, from the stand-point of description, a science of such exactitude that there is now little to be added to it. Still, they mistook the real seats of those states of the soul; and Descartes, in his famous work on the passions, was the first to hold that their seat is in the brain. He localized all passional states in that organ. "The soul," he says, "can suffer directly only through the brain;" and, in another place, "The

<sup>1</sup> "Reason sits arbitress within the breast;  
For there it is our conscious being dwells;  
There fear and dread anxiety creep chill,  
And soothing joys play flattering round the heart,  
Which shows the soul is there that joys and fears."

LUCRETIUS, C. F. JOHNSON'S TRANSLATION.

soul does not receive impressions from all parts of the body, but only from the brain." This truth, which now seems so elementary, was nevertheless demonstrated only by the physiology of recent times. The greatest physiological theorist of the passions, Bichat, did not accept it, as we shall see from an exposition of his doctrine.

The first physiological character recognized in the passions, by Bichat, is intermittency. Whereas our thoughts may be continued—prolonged over a considerable period of time—and whereas a habit of making the same reflections and judgments strengthens and perfects them, the passions, on the other hand, have no persistence. With the exception of that pleasure and pain which we might denominate absolute, and which depend on direct nerve-excitation, it may be asserted that a habit of the same sentiments will soon blunt and weaken them. A prolonged sensation, be it pleasant or painful, at last gives neither pleasure nor pain. The perfumer, who is ever surrounded by an odorous atmosphere, does not enjoy the sweet scents. All that delights the eye or charms the ear becomes indifferent when the impression has lasted for some time. The same holds good for disagreeable sensations. "Happiness, therefore," says Bichat, "consists only in discontinuousness. Pleasure is but a comparative sentiment, that ceases to exist where you have uniformity between present and past sensations. Were the forms of all women cast in one mould, that mould were the grave of love."

This profound difference between thought and passion Bichat explains by the theory that the former is dependent on that side of our being which we call *animal life*, while the latter proceeds from the *organic life*. Every thing that has to do with intellectual operations, properly so called, has its seat in the brain, which is the centre of animal life. Every thing that has to do with the passional states has its seat in the viscera. The effect of passion of every kind is to produce some change, some alteration in the organic life, that is to say, in the organs of circulation, of respiration, and of nutrition. This fundamental difference between intelligence and passion, as regards the organs which seem to be their respective seats, has long been remarked by popular sagacity and incorporated into language. Such expressions as "a good head," "a fine-shaped head," have always been employed to express perfection of understanding; and "a good heart," "a tender heart," to express the perfection of sentiment. It has also been a current phrase to say that the blood "boils" with anger, or that indignation "moves" the bile, or that the heart "leaps" with joy. Our gestures accord with our words: thus, when we would in dumb show indicate some state having to do with memory, imagination, perception, or judgment, we bring the hand up to the head. But, when we would express love, joy, hate, disgust, we bring the hand up to the region of the heart or of the stomach.

A close observation of facts proves the correctness of the instincts



that have given rise to these phrases and gestures. It is evident that anger accelerates the circulatory movement, and that joy has the same effect, while grief and fear produce the opposite results. Extreme emotions are sometimes followed by fatal syncope. Profound grief causes a difficulty of respiration. Sudden fright checks the secretion of bile. Independently of these palpable phenomena, the passions modify profoundly the nutritive processes, and give rise to disordered conditions, of a more or less grave nature. Here, again, language accords with physiology. *To pine away with envy, or with remorse, to waste away with grief,* are expressions that attest the influence of the passions on the organic life. Again, Bichat ingeniously notes the relation subsisting between the passions and the temperament. The individual whose lungs are highly developed, and whose circulatory system is specially vigorous, will naturally be of very impetuous disposition, choleric, passionate, and courageous. Where the biliary system predominates, enviousness and hate seem to be more habitual. The lymphatic temperament gives to the passions a quiet and indolent character. Thus every thing, according to Bichat, goes to show that the organic life is the terminus to which the passions tend, and the centre from which they start, and that the animal life only suffers from the rebound consecutively. If the focus of the animal life is the brain, then what is the focus of the organic life? What is the apparatus specially concerned in producing emotions and passional manifestations? Bichat holds that there is no one organ on which this office devolves exclusively, and he localizes the passions in what he calls the epigastric centre; that is to say, in the heart, the lungs, the liver, the gall-bladder, and the ganglionic nerve-system, distributed throughout these organs. Each of these is, according to him, the seat of a distinct passion, and the movements that are determined by this passion are perfectly involuntary.

Such is Bichat's doctrine of the passions; it is the ancient doctrine, only developed and elucidated, reasoned out with greater precision, and fortified with fresh proofs. It is correct in its analysis of the visceral disturbances produced by the passions, but erroneous in that it regards the viscera as their main-spring and origin. To Gall belongs the honor of having proved that the passions primarily affect the brain, and not the viscera. It was the experiments made by that great man which showed that the brain is the organ of sentiments no less than of ideas. His argument against Bichat's theory may be reduced to these fundamental observations: The heart and the diaphragm are only muscles, the stomach and the liver only secretory apparatus, the kidneys only an excretory apparatus, and the spleen only a sanguineous gland. Several of these organs may suffer lesion or be removed and still the passions remain; hence we cannot localize the passions in them. Gall, in the next place, examines all the parts of the nervous system outside of the brain, viz., the plexuses, the ganglia, the nerves, and the sensory

apparatus, and shows that here too it is impossible to find the source of our propensities, instincts, affections, or passions. Finally, he examines the brain itself, and in it discovers the exclusive seat of all these activities. That the passions depend essentially on the brain is proved from the fact that any impairment of that viscus determines a perturbation of the passional no less than of the intellectual phenomena. When we see physicians of half a century ago, who were profoundly versed in the study of insanity—a Pinel or an Esquirol, for instance—hesitate about locating in the brain the immediate cause of dementia and the various forms of mania, we can appreciate the importance of the service done by Gall to the science of man, when he rigorously demonstrated the ill-understood functions of the brain, and proved the correctness of Descartes's doctrine of the passions.

The experiments of modern physiologists, those of Claude Bernard in particular, show that all sensations act primarily on the nerve-centres, through the nerves reaching from the periphery of the body to those centres. The excitation thus determined in the brain, or in the spinal cord, is then transferred to the nerve-filaments which extend to the viscera and members, and hence the latter are affected only secondarily. Of all the organs, the heart is the one which earliest and most profoundly experiences the influence of the sensitive excitations produced in the nerve-centres. So soon as any modification whatsoever is produced in the central nerve-substance, the nerves transmit this vibration to the heart, and at once the movements of the latter suffer a perturbation which is expressed in various ways. At one time the nervous action is sufficiently energetic to at once stop the working of the heart; and, as the blood is no longer discharged into the vessels, syncope (fainting) is the result, the skin assuming the pallor and lividness of death. Again, the reverse effect takes place, the beating of the heart being accelerated, instead of being stopped; in this case the blood is forced through the distended vessels to the brain, and there is over-excitation of that organ's activity. The heart is no more the seat of the sentiments than the hand is the seat of the will, but it is a *reactive* which is modified by the sentiments, with the utmost nicety and with infallible certainty. Not only does the heart betray, by the very disturbance of its normal rhythm, the nature of the initial brain-excitation, but it also produces throughout the whole organism disordered actions, the sum of which constitutes, as it were, the physical image, the palpable externals of passion. But it produces this disordered action only by reacting on the brain, which is the organ of all the demonstrations and of all the movements of the nerves, and consequently of the muscles. Thus it is that the heart and the brain, the blood-system and the nerve-system, conspire in the production of passional phenomena, by a series of alternate actions and reactions.

Such, are at least, the chief points of Claude Bernard's doctrine, as set forth at a famous Sorbonne *conférence*, in 1864. At that period the

nature of the nerve-connections of the heart with the brain were as yet unknown, and a Russian physiologist, E. Cyon, has, for some years past, labored successfully to fill up this gap. The heart is provided with a number of little self-acting nerve-ganglia, without relations to the brain, from which spring, under the influence of the blood, a certain number of motor impulsions. These ganglia govern the usual normal action of the cardiac apparatus; but the rhythm and the force of the beatings are every instant modified by excitations having their origin in the brain. The latter organ sends out to the ganglia of the heart two sets of nerves—the pneumogastric, or retardator, and the accelerator nerves. Excitation of the former diminishes the frequency and augments the force of the heart's movements. The accelerator nerves produce the opposite result, increasing the number and lessening the force of the heart's contractions. These two sets of nerves accommodate the activity of the heart to that of the rest of the organism, and hold it in equilibrium with the continual oscillations of the various functions of body and soul. Besides these filaments, extending from the brain to the heart, there are others from the heart to the brain, which M. Cyon calls *depressors*. The office of these nerves is to notify the brain, and consequently the soul, of the changes occurring in the rhythm and energy of the cardiac contractions. Thus, in virtue of the pneumogastric and the accelerator nerves, the heart is an organ whereon is reflected, immediately and with precision, every pas-sional state, with its nicest shades of distinction. And, on the other hand, in virtue of the depressor-nerves, our consciousness notes the infinitely-diverse oscillations of the heart's beatings attendant on pas-sional states. The mechanism of the heart's motions under passion depends on these two inverse nerve-currents.

Every agreeable or joyous emotion of the soul excites the accelerator nerves of the heart, and causes that organ to beat with great rapidity, lessening at the same time the force of its contractions. The phrases, *the heart leaps with joy*, or *flutters with joy*, admirably characterize this action of the accelerator nerves. The facility with which the heart drives the blood into the arteries, under such circumstances, produces that feeling of comfort and pleasure which is expressed by the words, *a light heart*. On the other hand, all sad or painful feelings act chiefly on the retardator fibres of the pneumogastric nerves. Emotions of this description diminish the rapidity of the heart's beatings, and so increase the amount of blood discharged from that organ at each diastole; hence the contractions by which it drives the blood into the vessels are laborious and protracted. These contractions, attended as they are with pain, give rise to an *ensemble* of sensations, expressed in common language by such phrases as *oppression of the heart*, *the heart is agonized*, etc. That other phrase, *the heart is ready to burst*, expresses, with great exactitude, the sensation of stricture one feels when suffering from pent-up anguish. The news of some

painful loss, when suddenly conveyed, oftentimes produces wild, irregular contractions, owing to a paralysis of the retardator nerves, and it is not rare to find this disordered excitation followed by a total stoppage of the heart's action, and syncope. Hence, says Claude Bernard, when we have to communicate to a person some *heart-breaking* piece of intelligence, we must use great precaution. The intensity of the effects produced on the heart by the soul's emotions depends, above all, on the excitability of the nerves connecting heart and brain. The greater the excitability of these nerves, the more pronounced are the heart's motions, and the finer, too, and the more delicate are the consecutive impressions. It is because the nerves of women and children are more excitable than those of men, that their hearts also are more profoundly affected by the emotions; or, in common language, their hearts are more tender, more sensitive.

While the heart seems to be more directly under the influence of the feelings, the lungs appear to have some connection with thought. When absorbed in some profound meditation, or when listening to some orator whose discourse rivets our attention, we suspend the respiratory movements. Darwin offers an ingenious explanation of this phenomenon, attributing it to the habit we have contracted of not breathing when we are listening attentively, so as not to disturb by the sound of the breath the silence necessary for catching every syllable.

From the fact that the real affections of the soul, and consequently of the brain, are always accompanied by disturbance of the respiratory and circulatory functions, we may conclude that the heart and the arterial tension are the true index of the passional states. Hence it is that the actor, when he would prove that some perilous situation inspires him with no fears, seizes the hand of the one he seeks to reassure or to convince, and places it over his own heart, in order to show that the beatings of that organ keep up their usual rhythm. Hence, too, it is that we must not regard outcries and gestures as positive indices of passion. When you see a woman weeping and agitated on hearing some painful news, you have only to feel her pulse; if that is normal, you may pronounce the emotion simulated. On the other hand, if you see a woman whose distress is manifested by no outward signs, but whose heart beats with unwonted irregularity, you may be sure that she feigns a calm that is not in her soul. There is yet another mode of ascertaining, and even of measuring accurately, the strength of emotions. This we may do by applying either to the pulse or to the heart one of those delicate apparatus invented by M. Marey, which trace on a sheet of blackened paper curves of greater or less sinuosity, representing the number, the force, and the form of the beats of the pulse, or the contractions of the heart. Just as these apparatus give us tracings which at once indicate the nature of the heart's motions in various diseases, for instance, fever, typhus, or pneu-

monia, they might in like manner give us graphic representations of its motions under the influence of the various passions, such as love, fear, grief, joy, anger, etc. Indeed, each of these states of the soul produces, in the order of the heart's beatings, a modification so peculiar and characteristic that we may regard each of the passions as having a curve of its own. M. Cyon, who has recently suggested this ingenious idea of applying graphic apparatus to the physiology of the passions, gives some illustrations of the bearings such experiments might have. Among the heirs gathered round the bed of a dying man there is one whose grief causes his heart to beat slowly but violently. In some of the others, who impatiently await the end, the heart beats quickly but feebly. The graphic apparatus, which describes, with marvelous precision, the rhythm of cardiac contractions, and which is called the *cardiograph*, could in this case exhibit the real feelings of the heirs. This is not at all an exaggeration, and we have no doubt that an instrument of great sensibility could be got to note the differences here referred to. Perhaps the case would be different under circumstances of greater complexity. The modifications of the heart's beating intervene in a twofold manner, in the determination of our inclinations and in the acts which proceed from them, either by producing sudden changes in the quantity of blood diffused through the nerve-centres, or by giving us agreeable or painful sensations through the depressor nerves. Now, a sudden afflux of blood to the brain, and extremely painful sensations, may produce, in a man not suffering from any mental disease, the craziest notions, and may betray him into the commission of the most serious offenses. Suppose a man commits a crime under circumstances but ill understood; the question arises, Was he moved to the act unconsciously and by physiological causes, or did he do it designedly and after calm reflection? M. Cyon thinks he can resolve this problem as follows: The soul possesses the faculty of experiencing, on the recollection of a past act, emotions of a like kind with those it experienced at the moment of its commission. The detailed history of a crime must produce in the accused who listens to it—supposing that he had committed the crime knowingly—emotions of this kind, as also the cardiac motions necessarily correlative to them. Hence the judge may, by means of the cardiograph, inform himself as to the presence or absence of these motions, and so decide whether the accused has or has not a recollection of the crime, i. e., has committed the crime whether with or without consciousness. This instance is rather ingenious than plausible, rather theoretic than practical. Of course, an individual who has committed a crime in a state of delirium cannot, on hearing the history of that crime, experience the same emotions, nor consequently the same modifications of the heart's movement, as he would if he had committed it with a full knowledge of what he was doing; still, it would be as hard for him in the one case as in the other, to maintain an absolute *sang-froid*. A man who is

accused of having committed a crime, and who knows that he has committed it, is alarmed at the sight of the judge who questions him, and at the thought of the accusation which stands against him, even though the crime was committed in a moment of delirium. On the other hand, it may easily happen that a hardened malefactor, who has committed a crime with full deliberation, will be so far master of himself as to feel but insignificant emotion when the circumstances of his crime are brought up before him. Yet this idea of M. Cyon's merits the attention of psychological physiologists, and we may venture to hope that the day will come when treatises on psychology will conclude their descriptions of passional states with graphic tracings showing the rhythm of heart-contractions which answers to each passion. These tracings will be trustworthy and precise, for, if the will be mistress of movements and demonstrations that appear at the surface, it has but very little power over viscera that are concealed, like the heart, and these are truthful witnesses, ever at hand to rectify lying testimony.

## II.

But we must bear in mind that muscles which are subject to the will are not always employed to dissemble passion, but that very often, by their almost automatic attitude, they betray the real state of the feelings. In vain would a man in a furious passion strive to stand still. All his members are agitated with violent movements. Astonishment produces a relaxation of the muscles, and hence the French phrase, *les bras tombent* (the arms fall), to denote the effects of this emotion. Fear causes one's legs to fail him; one is said to be *petrified* by fear. But there are none of the muscles that are so influenced, so modified by the passions, as those of the face. The physiognomy is indeed a betrayer of the soul's inner states. "When the soul is agitated," says Buffon, "the face becomes a living picture, wherein the passions are given with equal delicacy and force; where every movement of the soul is expressed by a dash of the pencil, and each act by a character, the rapid, living impress of which outstrips the will, thus unveiling and manifesting, by passionate signs, our most secret emotions."

It seems impossible to subject to physiological analysis appearances so complex, so varied, and so fickle. And yet an accomplished experimenter has recently succeeded in partially ordering this chaos, and in precisely determining the muscular mechanism of the human physiognomy as related to the various passions. Having first ascertained, by minute dissections, the position and separate function of the numerous muscles situate between the skin and the facial bones, and having learned how the nerve-filaments of the *seventh pair* (the facial nerves) are distributed through these muscles and animate them, M. Duchenne, of Boulogne, has determined, by means of the electric current, or of



various excitants, the contraction of each particular one of these little muscles. Again, by observing those ready-made experiments which we call diseases, he learned what takes place when some of these muscles contract while others are inactive. In this way he has been enabled to see, most clearly, that the contraction of each muscle of the face determines a certain invariable expression; that is to say, that each passion seems to have at its command a facial muscle which contracts so soon as the soul is moved by this passion. M. Duchenne discourses as follows about the *muscle of suffering* (*souffrance*), as he calls the muscle whose contraction indicates pain. "From the very outset I had observed that the partial movement of one of the motor muscles of the eyebrow always produced a complete expression in the human face. For instance, there is one muscle which expresses pain—the superciliary muscle. On causing this to contract by electricity, not only did the eyebrow assume the form expressive of pain, but the other parts and features of the countenance, particularly the mouth and the naso-labial line, seemed also to undergo a profound modification, so as to harmonize with the eyebrow, and, like it, to give expression to this painful state of the soul." So, then, other muscles appear to share with the superciliary in the expression of suffering. M. Duchenne, however, believes that he is authorized by his experiments in holding that the muscular region of the face directly modified by a single passion is very circumscribed. But this modified region acts by a sort of sympathy on the adjacent regions precisely as one color modifies the tint of the colors all around it; and, just as, in the latter case, there is caused an optical illusion, the result of what Chevreul calls the simultaneous contrast of colors, so with the muscular movements of the face there is produced a kind of mirage which modifies, complicates, and seems to dilate a movement whose real sphere is very restricted. However this may be, M. Duchenne has succeeded in reproducing, by contractions called forth in a certain number of the facial muscles, nearly all those expressions which answer to the inner states of the soul, and he has thus been enabled to assign to each muscle a psychological in addition to its physiological name. Thus, the frontal muscle is the muscle of attention, surprise, wonder, and alarm, and each of these emotions excites it in a different way. The great zygomatic and the inferior orbicular muscles are the muscles of joy, while the pyramidal muscle of the nose is the muscle of aggression, and so on. In general, the muscles of the eye are adapted to expressions of the higher order, and those of the mouth to expressions of a more gross and material kind. The purely self-satisfied and sensual smile calls into play only the zygomatic muscle. It is the contraction of the inferior orbicular that gives to the expression of contentment and pleasure a character of goodness and benevolence. Besides the primary expressions resulting directly from the play of one muscle, M. Duchenne finds that several

passional states of the physiognomy may be resolved into a number of simple movements.

And, just as he produces simple passional expressions by artificial means, so, too, he effects the synthesis of the complex expressions. *Attention*, which is produced by the contraction of the frontal muscle, and *joy*, which is due to the conjoint activity of the great zygomatic and the inferior orbicular, are primary expressions. Whenever we determine simultaneously on one face the contraction of these two muscles, we get the physiognomy of a person who has a lively impression of some pleasing and unexpected news. If, together with these muscles, we excite that which serves to express lechery—i. e., the transverse nasal muscle—we get the type of *attention directed toward some lascivious object*. If we associate the lines indicating pleasure with those denoting pain, we recognize at once the melancholy smile. When we combine the smile (by contracting the great zygomatic) with gentle grief (by contracting the minor zygomatic), or, better still, with a slight contraction of the muscle of suffering—the superciliary—we have an admirable and touching expression of pity and compassion.

These fine physiological dissections, and the masterly syntheses they suggested to M. Duchenne, are nearly in full accord, as concerns their results, with the most ancient observations of empiricism, with the intuitions of painters and sculptors, as also with the teaching of psychologists and moralists. Results of this kind add nothing to our knowledge of the body or of the mind, but they will, perhaps, be of service to artists who desire to be exact in the anatomical reproduction of the passional movements of the physiognomy. No doubt the genius of superior artists is a sure and potent instinct, which leads them to follow rules they know not; and it is probable that neither Raffaele, nor Correggio, nor Titian, would have been a greater painter, had he known, as modern physicists do, the laws of harmony and the simultaneous contrast of colors. Nevertheless, this sure and potent instinct, the germ of which exists in the *élite* of the artist-world, may be to some extent acquired by laborious study, and hence the conscientious artist will understand all the advantage to be derived from a science which, by giving him precise and certain directions, will save him much preliminary labor and much fruitless experiment.

Why is one special muscle of the face affected by pain, another by fear, and a third by anger? In short, why is every passion interpreted in the physiognomy by regular, determinate movements, just as the rhythm of the heart is modified? To give the question a more general form, is there a logical relation between gesture and emotion? This is a difficult question, recently put by Mr. Darwin, and which he strives to answer in accordance with his usual doctrines. For him, instincts are habits originally acquired purposely, voluntarily, and afterward fixed in the race by heredity. The instinctive movements of the physiognomy, considered as passional ex-

pressions, have the same origin. Thus, the habit of praying with the hands joined palm to palm comes, according to him, from the fact that in past times captives testified their entire submission by holding up their hands to be bound by the victor. The captive assumed the kneeling posture, in order to make this operation easier. Thus, the gesture and the attitude, which are now the instinctive expression of adoration, of devotion, would be merely vestiges of the savage usages of primitive man. When we are angry with a person, we involuntarily close our fists, so that they may be ready for use, even when we have no intention of striking the one who has angered us. If, under the action of similar feelings, the lips contract so as to show the teeth, as though we were preparing to bite, the reason is, says Darwin, that we are descended from animals who used their teeth as weapons of offense. Why do the eyebrows assume an oblique position when a person is suffering pain? For this reason: when children cry from hunger or from pain, the act of crying profoundly modifies the circulation; the blood flows to the head, and particularly to the eyes, and this produces an unpleasant sensation. The muscles around the eyes then contract so as to protect them, and this action has become, under the influence of selection and heredity, an instinctive habit.

Most of Mr. Darwin's ingenious explanations thus tend to refer movements of the physiognomy, that are now involuntary and instinctive, to movements that once were voluntary and intentional. Many of these explanations seem plausible, but it is nevertheless true that the physiognomy betrays the emotions and passions by means of signs entirely independent of the will. That some of the muscular movements of the face arose in the manner described by Darwin we might admit, but still we cannot see how that accomplished naturalist can reduce under his fundamental hypothesis those complex movements which are expressed by laughter, lachrymal secretion, blushing, pallor, turgescence or flaccidity of the flesh, and the flashing and dimming of the eyes. All these phenomena are entirely independent of the will, nor can they be explained on the theory put forward by Darwin to account for the eyebrow contracting under the influence of painful emotions, or for the lips contracting in anger. Therefore, we are forced to the conclusion that the agitation of the cephalic centres, produced by the passions, calls forth, in virtue of the anatomical relations of those centres with the facial nerves and muscles, reflex phenomena that never were under the control of the will. The habit of seeing such and such an expression associated with such and such a passion leads us to judge of the one by the other; but yet the habit is not the efficient cause of the expression.

There still remains to be considered one more series of physiological phenomena which bear the impress of passion, viz., vocal phenomena. The inflections of the voice, as related to the passions, are as varied as the expressions of the physiognomy. Each passion has its

own language, its own tones, its own note, just as it has its own nerve and its own muscle. Physiological analysis, however, is far more difficult here than in the case of the physiognomy. How shall we analyze the complex mechanisms that cause the lungs and the larynx to produce the various sounds of moaning, crying, groaning, sobbing, and sighing? We are acquainted with the *ensemble* of muscular functions which give rise to these different expressions of the soul's states, but why does laughter express gayety, and sighing express sadness? We cannot tell.

To sum up: a profound disturbance of the circulatory and respiratory acts; a more or less violent agitation of the members; changes of the attitude of the body; diversified movements in the physiognomy; infinitely-varied inflections and modulations of the voice—all these phenomena are the consequence of what takes place in the brain when that organ receives impressions of such a nature as to agitate it.

Hence we see that the main-spring of passion is the sense-impression. But what is this impression? In order to answer this question, let us analyze some passional state. We shall there find four principal elements: a more or less distinct initial sensation of pleasure or pain; voluntary or involuntary movements, more or less pronounced; and, finally, a recurrent sensation consecutive to these movements. It is clear that if there were no sensation there would be no passion. On the other hand, if the sensation were but a motion, we might say that passion consists of a series of motions originating in the agitation of the sensorium produced by the internal or external causes of emotion; but, then, we never could understand why this agitation, being purely vibratory, should affect us at one time agreeably, at another painfully, or why it should act in so many different modes. Hence the power of discerning, immediately, in the sensorial perception, differences that have no mechanical equivalent, cannot be explained on mechanical grounds, and it is absolutely necessary to recognize here a psychic faculty, whose function it is to ascertain and to conceive the causes of emotions, and to regulate, according to a certain harmony, the consecutive physiological movements. Passion, therefore, resides in a something that is neither the brain, nor the nerves, nor the muscles; a something which perceives, and joys, and suffers, and which moves the entire body in unison with its own feelings. Now, this conscious faculty, this faculty of perceiving causes in no wise mechanical, is the soul. The more deeply we study the physiology of the passions, the more are we convinced that the agitation of the nervous and motor energies is but the external manifestation of deeper causes, which we denominate psychic. So, too, the more we study into matter, the better we see that it is only an external form, a vesture that clothes the activity of an invisible principle. Thus does Science ever lead us back to that eternal and mysterious thing, force, and, beyond force, to spirit.—*Revue des Deux Mondes.*

## OUR ANCESTORS ON THE GOOSE QUESTION.

LET us consider the views entertained by our ancestors for centuries on the goose question: we may gather lessons from it that will be very applicable to-day. They believed for five hundred years that a certain kind of goose was of vegetable origin, and grew on trees. The story is ancient and obscure, and much ingenuity has been spent in explaining it. Without attempting to reconcile its contradictions, or account for its origin, we will only here give a brief outline of the tradition.

Belonging to that division of the animal kingdom known as articulates or jointed animals, there is a class called crustaceans, from the crust-like shell with which the body and legs are covered, and of which lobsters, crabs, and shrimps, are examples. Among these is a group known as "Cirripedia," from the *cirri*, or curls of hair, in which their long and slender feet terminate. They are inclosed in a more or less conical shell, and some of them are pedunculated; that is, their main body hangs from a stalk, pedicle, or peduncle, of varying length, which permits of some degree of motion. They attach themselves to floating objects, as plank, worm-eaten fragments of wreck, ships' sides, and sometimes to the cuticle of the whale. These creatures are more familiarly known as barnacles, and Fig. 1 represents a pendent group of common ship-barnacles, which are described as having "a flesh-colored, translucent, wrinkled stem, possibly more than a foot long, and from this stem there dangles a triangular, pearly-shelled fish, the valves of which, bordered with the most lovely orange, from time to time open and disclose several pairs of curling feelers." The soft part within this shell, in old times, used to be mistaken for a little bird.

There is in England a well-known species of goose called the barnacle-goose. "It is a winter migrant on the east coast; its summer home, where it breeds, being the high latitudes of Northern Europe. It is a very handsome species, a vegetable-feeder, and excellent eating." Now, it would seem to be a very simple matter to end the story by saying that it was long believed that barnacle-geese had their origin in the barnacle-shells we have just referred to, but the case is more complex; the shells bearing the geese were believed to grow on trees. This belief, that the barnacle-shell is transformed into the barnacle-goose, was well established, as early as the twelfth and thirteenth centuries, and was referred to and contradicted by both Albertus Magnus and by Roger Bacon. That the opinion was held as a firm reality is sufficiently proved by the fact that barnacle-geese were allowed to be eaten during Lent, under the idea that they were not fowl, but fish—an elastic zoology that served to widen ecclesiastical dietetics, although to the scandal of the more strict, as the practice

was inveighed against with great unktion by Sir Giraldus Cambrensis, who treated the subject, in the twelfth century, in his "Topographia Hiberniæ." Michel Drayton refers to it, in his "Polyolbion:"

"The barnacles with them, which, wheresoe'er they breed—  
On trees or rotten ships—yet to my fens for feed  
Continually they come, and chief abode do make,  
And very hardly forced my plenty to forsake."

FIG. 1.

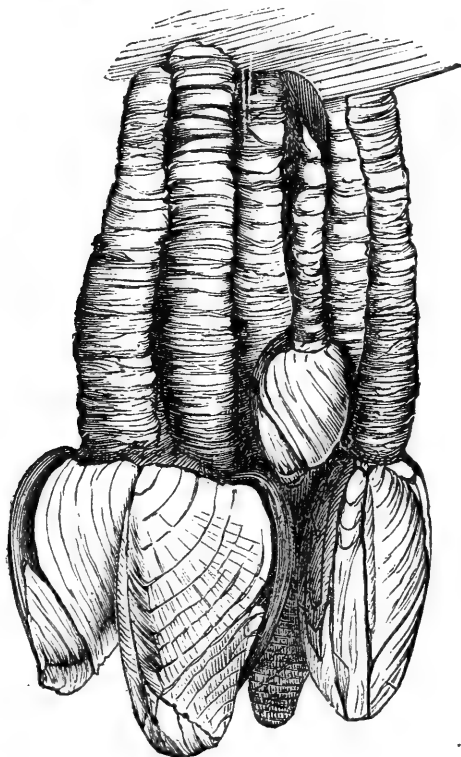

LEPAS ANATIFERA—COMMON SHIP-BARNACLES.

Baptista Porta refers to it, about the year 1500, and Count Meyer devoted a volume to it—"Volucris Arborea." The earliest published statement, *by an eye-witness*, is contained in the "Cosmograph and Description of Albion," of Hector Boëce, while the earliest pictorial illustration of the goose-tree, and its animal fruiting, is contained in the "Cosmographia Universalis" of Sebastian Munster, printed at Basel, 1572.

In the middle of the sixteenth century, Turner, the English ornithologist, wrote as follows: "Nobody has ever seen the nest or egg of the barnacle; nor is this marvelous, inasmuch as it is without parents, and is spontaneously generated in the following manner: When, at a certain time, an old ship, a plank, or a pine mast rots in the sea, something like fungus at first breaks out thereupon, which at length puts on the manifest form of birds. Afterward, these are clothed with feathers, and at last become living and flying fowl. Should this ap-



pear to any one to be fabulous, we might adduce the testimony not only of the whole people who dwell on the coasts of England, Ireland, and Scotland, but also that of the illustrious historiographer Gyraldus, who has written so eloquently of the history of Ireland, that the barnacles are produced in no other way. But since it is not very safe to trust to popular reports, and as I was, considering the singularity of

FIG. 2.

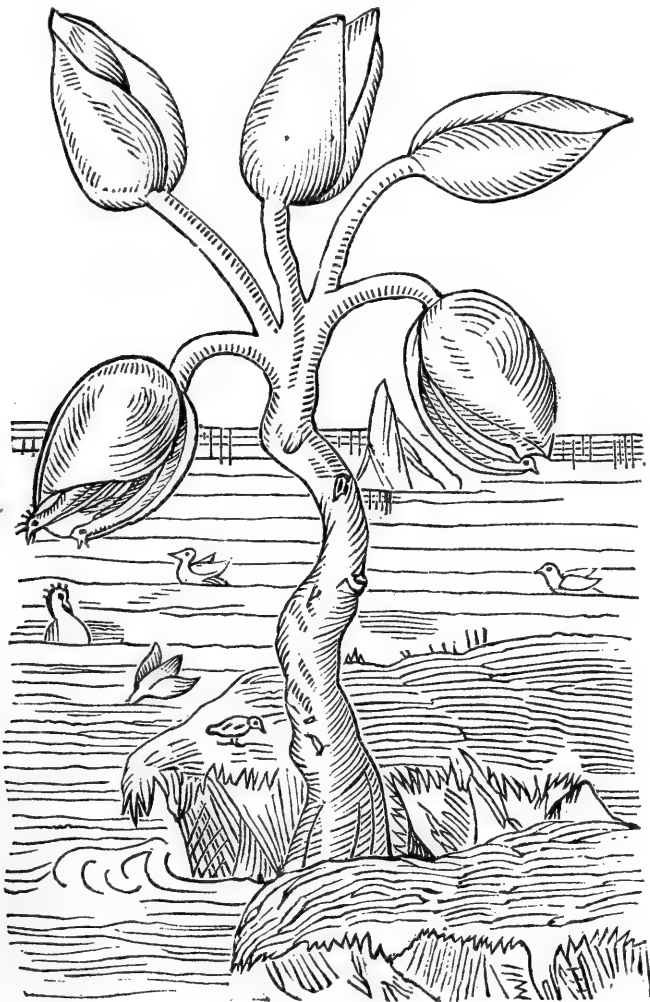

THE GOOSE-TREE.

"They spawne, as it were, in March and Aprill; the Geese are found in Maie and June, and come to fulnesse of feathers in the moneth after. And thus hauing, through God's assistance, discoursed somewhat at large of Grasses, Herbes, Shrubs, Trees, Mosses, and certaine excrescences of the earth, with other things moe incident to the Historie thereof, we conclude and ende our present volume, with this woonder of England. For which God's name be euer honoured and praised."—(GERARDE, "Herball," 1633.)

the thing, rather skeptical even with respect to the testimony of Gyraldus—while I was thinking over the subject—I consulted Octavian, an Irish clergyman, whose strict integrity gave me the utmost confidence in him, as to whether he considered Gyraldus worthy to be trusted in what he had written. This clergyman then professed himself ready to take his oath upon the Gospels, that what Gyraldus had

recorded of the generation of this bird was most true; for he himself had seen with his eyes, and also handled those half-formed birds; and he said further that, if I remained a couple of months longer in London, he would have some sent to me."—(TURNER'S "Avium Præcip. Hist.," art. "Ansr.")

But the writer to whom we are most indebted for authentic information upon this interesting subject is Gerarde, the father of English botany, and author of the "Herbal," a ponderous work of 1,500 pages, from which the cut Fig. 2 is taken. He says: "What our eyes have seen, and hands have touched, we shall declare. There is a small island in Lancashire, called the Pile of Flounders, wherein are found broken pieces of old and bruised ships, some whereof have been cast thither by shipwreck, and also the trunks and bodies, with the branches, of old and rotten trees, cast up there likewise; whereon is found a certain spume, or froth, that in time breedeth unto certain shells, in shape like those of the mussel, but sharper pointed, and of a whitish color, wherein is contained a thing in form like a lace of silk finely woven, as it were, together, of a whitish color; one end whereof is fastened unto the inside of the shell, even as the fish of oysters and mussels are; the other end is made fast unto the belly of a rude mass or lump, which in time cometh to the shape and form of a bird. When it is perfectly formed the shell gapeth wide open, and the first thing that appeareth is the aforesaid lace or string; next come the legs of the bird hanging out, and as it groweth greater it openeth the shell by degrees, till at length it has all come forth, and hangeth only by the bill. In short space after it cometh to full maturity, and falleth into the sea, where it gathereth feathers, and groweth to a fowl bigger than a mallard and lesser than a goose, having black legs, and bill or beak, and feathers black and white, spotted in such manner as our magpie, called in some places pie-annet, which the people of Lancashire call by no other name than tree-goose; which place aforesaid, and of all those places adjoining, do so much abound therewith, that one of the best is bought for threepence. For the truth thereof, if any doubt, may it please them to repair to me, and I shall satisfy them by the testimony of good witnesses."

Again says Gerarde: "The historie whereof to set fourth according to the woorthiness and raritie thereof, woulde not onely require a large and peculiar volume, but also a deeper search into the bowels of Nature than my intended purpose wil suffer me to wade into, my insufficiencie also considered, leaving the historie thereof rough-hewen unto some excellent men, learned in the secrets of Nature, to be both fined and refined; in the mean space take it as it falleth out, the naked and bare truth, though unpolished."

When the Royal Society of England had been established fifteen years, this fable was accepted, and described in the philosophic transactions, in 1677, by Sir Robert Murray, who says: "Being on the

island of Uist (East) I saw lying upon the shore a cut of a large fir-tree, about two and half feet in diameter, and nine or ten feet long, which had lain so long out of the water that it was very dry, and most of the shells that had formerly covered it were worn or rubbed off. Only on the parts that lay next the ground there still hung multitudes of little shells. This barnacle-shell is thin about the edges, and about half as thick as broad. Every one of the shells has some cross-seams or sections, which, as I remember, divide it into five parts. These parts are fastened one to another with such a film as mussel-shells have. These shells are hung at the tree by a neck, longer than the shell, of a kind of filmy substance, round and hollow, and curved not unlike the windpipe of a chicken, spreading out broader to where it is fastened to the tree, from which it seems to draw and convey the matter which serves for the growth and vegetation of the shell and little bird within it. In every shell that I opened I found a perfect sea-fowl: the little bill, like that of a goose, the eyes marked, the head, neck, breast, wings, tail, and feet formed; the feathers everywhere perfectly shaped, and blackish-colored; and the feet like those of other water-fowl, to my best remembrance."

Many conjectures have been offered as to the origin of this strange myth, and Max Müller suggests the hypothesis that it came from the early misapplication of terms. He remarks: "No man would have suspected Linnæus of having shared the vulgar error, nevertheless he retained the name *Anatifera*, or duck-bearing, as given to the shell, and that of *Bernicula*, as given to the goose."



## ALTERNATIONS IN THE INTENSITY OF DISEASES.

FROM THE FRENCH OF ALPHONSE DE CANDOLLE.

TRANSLATED BY H. H. W.

THE diminution of the efficacy of vaccination, as a preservative from the small-pox, has been the subject, at first of incredulity, and afterward of surprise, to the medical world, and even to the non-professional public. The causes of this change have been sought in the nature of the vaccine matter. But it has not been demonstrated that taking the matter anew from the cow is to restore the primitive efficacy of the remedy.

Without wishing to call in question with the profession the chances of discovering an explanation, drawn from the domain of medical and physiological facts which they occupy, I desire to point out a consequence of the fundamental law of heredity, as applied to the phenomenon in question. In order to understand the subject in its true

aspects, it will be well, in the first place, to recall a fact in relation to epidemics.

Medical history proves, on the subject of epidemic and contagious maladies, a marked fatality at the time of their first appearance, followed by slowly-decreasing violence from generation to generation. In our own memory the epidemic visits of cholera have diminished in frequency and intensity within a short period of time. Previously to our day, syphilis and varioloid, two infective diseases, differing in their nature, and in their modes of transmission, had presented the same phenomenon—Extreme intensity at the beginning, diminution from period to period.

If this diminution belonged to the nature of the maladies, populations infected for the first time in the nineteenth century should have suffered less than those infected in previous centuries. But this is not what has occurred. When a savage population has recently been visited, for the first time, by the infection of small-pox, it has suffered as much as the Europeans at the beginning of the malady in Europe. It is the fact of invading a new field which renders epidemics destructive. Upon a little reflection, the reason of this is easy to comprehend.

When an epidemic falls upon a population for the first time, the greater part of the individuals disposed to receive the disease are attacked. They die in great numbers. Subsequent births are the offspring of persons who did not contract the disease, or, at the least, who contracted, yet survived it; that is to say, of persons better constituted than others to resist the disease. By virtue of the ordinary resemblance of children to their parents, the new generation will be less disposed to suffer from the epidemic. There will be then a diminution of the violence of the disease, or a temporary disappearance. For the most part I presume a *diminution*, because that the resemblance of children to their grandparents (which is called atavism) is not very rare, and tends to reproduce certain forms or physiological conditions in families. At the end of two or three generations, that special cause for the return of the epidemic is less felt, the resemblance to a great-grandfather, or ancestor still more removed, being more rare than the resemblance to a grandfather. But then the bulk of the population will no more have been exposed, by itself, or by its fathers and mothers, to the malady in question, or will have been but slightly exposed. Thus is constituted anew, by the very purity of the disease, a proportion of individuals who have not been submitted to the proof of the infection, or of whom the parents have not been submitted to the test; a proportion on whom the malady will be severe, and among whom the law of selection will recommence to operate.

The law of events (*force des choses*) introduces then a variation in the intensity of every disease, except that it does not act upon diseases of which people rarely die, or which fall principally upon the

aged. The more fatal a disease among youth, the quicker is the work of the law of selection, and the more prompt the diminution of the malady. If a first invasion, for instance, destroys a moiety of the population below marriageable age, the survivors should be very little liable, in their physical or physiological conditions, to the disease, and the children born to them will profit by their immunity. If the disease is less fatal, the purification will be less. We thus discover, I do not say *the* cause, but a cause why pestilences and other very serious maladies attack populations at intervals, and are, as it is said, epidemic; while certain diseases less serious, even among maladies which attack youth, rule from year to year in a mode more continuous.

Such are the clear laws—one might add the rigid laws—which rule in diseases, to produce aggravation or diminution, independently of all these natural circumstances. Without doubt there may be other circumstances, physical or physiological, and physicians may discover preventive or curative means which exert influence upon them. But the incessant effect of heredity, and of the law of selection, exists, notwithstanding; and, when other influences cannot be demonstrated, we may be assured that heredity and selection perform their part.

We now see that the efficacy of preventive means, such as vaccination, should also vary. When Jenner discovered the utility of vaccination, the small-pox had in a slight degree lost, in Europe, its primitive intensity. The people who then existed proceeded from many generations which could, thanks to the process of selection, passably resist the epidemic. Individuals were not so readily affected as at the origin of the disease, or, if they had the disease, they succumbed to it in a smaller proportion; or, yet again, those who survived rarely contracted the disease a second time. It was supposed that those who had the disease by inoculation were sheltered from a repetition, and the dangerous practice of inoculation would not have continued, but for this opinion. Vaccination, then, came at an epoch when the European population found itself in ameliorated conditions with regard to epidemic small-pox. Practised with ardor, it had the effect to render small-pox very rare. But, precisely because it had become rare in the generation which immediately succeeded Jenner, in the generation which issued from that was found a majority composed of persons who had not been exposed to the epidemic. Among them must have been some persons who naturally, or by atavism, were disposed to take the infection. From that cause arose a certain renewed sensitiveness (*recrudescence*), which vaccination could less easily control.

In other words, after two or three vaccinated generations, the European population having been slightly exposed to the small-pox, found itself approximating to the conditions of a population in which the disease appears for the first time. The attack is not altogether so

violent, but the return is evident. All means of resisting it, which would have sufficed fifty years since, have become less efficacious.

To sum all in general terms: heredity and selection must produce an alternation of intensity and relief in diseases. That variation must be more marked, when the disease in which it takes place is more fatal, and especially when it attacks youth. Curative or preventive means, which are sufficient in periods of light visitation, lose a portion of their efficacy at the aggravated periods. And this rule applies particularly to the use of vaccine as a preventive of small-pox.

The works of Darwin being now familiar to physicians, it is probable that many among them have considered the effect of the law of selection upon the variation of intensity in maladies. I doubt, however, whether they have given attention to the consequences relative to vaccination. It is this which has led me to bring within the range of medical investigation an application (perhaps novel) of the ideas of the celebrated English naturalist.

---

## MODERN OPTICS AND PAINTING.

By O. N. ROOD,

PROFESSOR OF PHYSICS IN COLUMBIA COLLEGE.

### II.

LET us now pass to the examination of a theory which was proposed in 1807 by the now justly-celebrated Thomas Young who seems to have been gifted with a scientific insight much too keen for the age in which he lived. His views being opposed to the common notions of the day, commanded but little attention, and it was reserved for Helmholtz, almost half a century later, to call attention to this nearly-forgotten theory, and to show that it accounted for all the ascertained facts in a most satisfactory manner. In this work he has been ably seconded by Maxwell, and more lately by the German physicist J. J. Müller, who with improved apparatus carefully repeated Helmholtz's original experiments, and corrected them in some minor details.

According to our new theory, then, there are in the retina of the eye, where the pictures of external objects fall, *three* sets of nerves, adapted for the production of three separate, distinct sensations, which we call red, green, and violet. When, owing to any cause whatever, one of these sets of nerves is excited into action, the result is the corresponding sensation; if, for example, we act upon the last set by electricity, pressure, or by the luminous waves, the result will be the sensation of seeing violet light, even though not a ray of light of any



kind has actually reached the eye. I think you will admit that the theory is modest in demanding only three sets of nerves, for in the ear, as it seems, there are three thousand nerve-fibrils for the perception of the separate notes. In the eye it would not have been practicable to have employed a separate nerve-fibril for each different tint, for a reason which a moment's thought will render manifest.

But to resume: according to our theory, the first set of nerves responds powerfully to the action of the longer waves, or to that kind of light which we call red; the second set is arranged for waves of medium length, it is strongly set in action by what we call green light; and, finally, the third set is stimulated into action by the shortest waves, or by violet light. Let us for the present call them the red, green, and violet nerves. This diagram shows their relation to the colors of the spectrum (*see* Fig. 1). As I have just intimated,

FIG. 1.

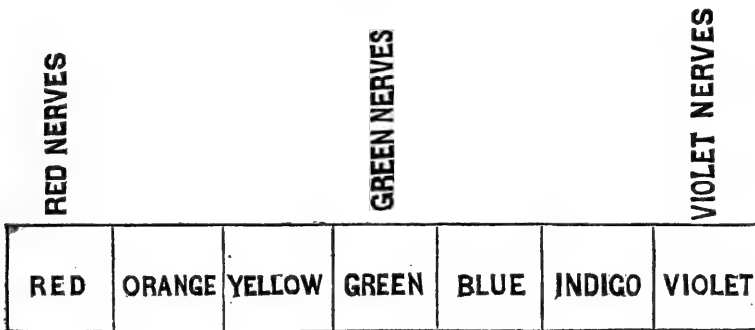

these nerves can be set into action by electricity or pressure, and other causes besides light. Taking this into consideration, the next point in the theory will not seem so singular to you: it is, that each set of nerves is capable of being acted on, to a lesser extent, by waves of light not properly belonging to it; so, for example, the set adapted for green light can, to some extent, be stimulated by red light. In a case like this, the sensation will still remain that which we call green, though actually produced by red light. The theory demands this, and the results of experiments on persons who are color-blind to red light are in accordance with it, and presently I hope to give some experimental illustrations of it. The red and violet nerves also have this property, and can be partially set into action by light which does not belong to them, but in each case the sensation remains the one that properly appertains to them.

The last point of the theory is, that, when by any cause all three sets of nerves are excited into action with about the same intensity, the resulting sensation is that which we call white.

We are now in a condition to take up the explanation of the sensations which we call yellow, orange, and blue. Let us suppose for a moment that the eye is acted upon by waves of light shorter

than those that produce the sensation of red, but longer than those that give us that of green; referring to Fig. 1, we see that no especial set of nerves has been provided for this case, but a moment's reflection will suggest that these intermediate waves, according to our theory, ought to set into moderate action both the red and green nerves, that the stimulation of the former should predominate as the length of our intermediate waves is made longer; the green set, on the other hand, coming more into play as it is shortened. This accounts, then, for the mode in which waves of a certain length, or light of a certain kind, gives us the sensation of yellow or orange. The light may be simple, and of only one kind, but it produces a compound sensation, made up of the two simple sensations, red and green. From all this it follows that, on the other hand, if we actually present to the same eye mixtures of red and green light, the sensations of yellow or orange ought, according to our theory, to be produced. This is a matter that we can easily test by experiment. With the same apparatus used a moment ago for combining blue and yellow light, I throw upon the screen a large square of red light, and superimpose on it one of green, and, as you see, the result is a fair yellow; on reducing the brightness of the green component, the yellow passes into orange (Fig. 2). I call your attention, in passing, to the circumstance

FIG. 2.

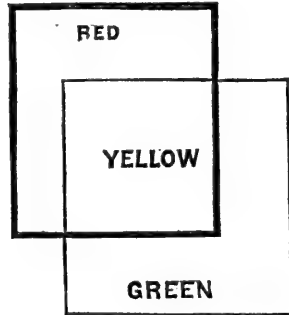

that, according to the old theory, the result ought not to have been yellow, but rather an approach to white, all the colors, according to its doctrines, being present. Restoring the green squares to their original brightness, and reducing the intensity of the red light, we easily obtain a greenish yellow, completing thus this series of tints.

And now to account for the blue: pure blue light has a wavelength intermediate between that of green and violet light, and hence sets both the green and violet nerves into action, and, though the light itself may be simple, it produces a compound sensation which we call blue. Corresponding to this, I ought to be able to reproduce on the screen blue light by mixing together green and violet light. The experiment is now arranged, and, as you see, we actually do obtain a quite good blue in this way, and can cause it to run through all

the changes from greenish blue to violet blue, by altering the intensity of the original components (Fig. 3).

It is easy for us now to understand why, in what I some time ago called our fundamental experiment, yellow and blue light, when mingled, gave not green, but white light; the yellow light stimulated into action the red and green nerves, the blue light the green and violet ones; thus, all three sets of nerves being called into play, the result was of course the sensation of white.

FIG. 3.

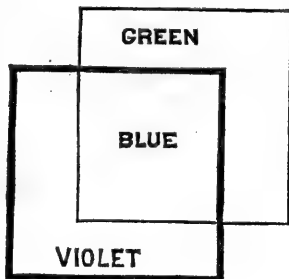

As it will be desirable hereafter to mingle light by the method of revolving disks, it may be well at this point to repeat our fundamental experiment after this fashion, so as to be assured of the correctness of this mode of experimenting. I have placed in front of the lantern a small circular card-board disk, provided with openings over which are fastened pieces of yellow and blue glass (Fig. 4); its

FIG. 4.

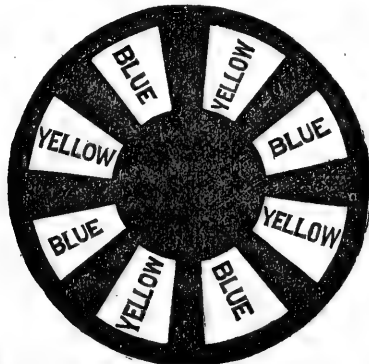

magnified image now covers pretty much the whole screen, and, on causing it to revolve, the colors as you see vanish, and we have in their place a broad circular band of white light (Fig. 5). With a concave mirror, I throw beside it on the screen a direct beam of white light from the lantern, and, if there is any difference, it is in the light from the disk being a little whiter than that of the lantern. The method with revolving disks gives, then, the same result with the more direct one formerly applied, and we can now very conveniently use it for a final test of the new and old theories. Here is

a disk cut like the last with open spaces, and armed with red, yellow, and blue glasses. You can predict the result beforehand: it must be white light with added red light—and, as you see, we actually do obtain a broad circular band of red light. Replacing this disk by one provided with glasses capable of transmitting red, green,

FIG. 5.



and violet light, we find that their mixture actually gives us white light. In all these experiments we have been content with the colored light furnished by stained glasses, but Helmholtz has pushed the investigation much further, and has obtained corresponding results by the use of the pure colored rays of the spectrum.

I called your attention some time ago to the typical mode of expressing the old theory by three intersecting circles of red, yellow, and blue; we have now again on the screen three intersecting circles; the colors are red, green, and violet, with white at the centre

FIG. 6.

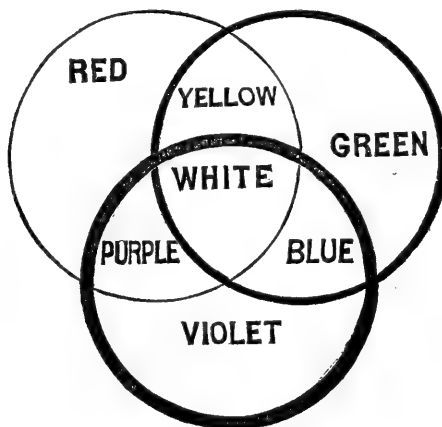

(Fig. 6). It expresses in a condensed form some of the main points of the theory of Young and Helmholtz, and gives us at the same time some of the chief laws of Nature's palette, showing, in a kind of short-hand way, the changes which the tints of surfaces undergo

when exposed to a double illumination, or when illuminated by light having a hue different from that of the surface itself. Applications of it will be given at a later stage.

Before leaving this part of the subject, I wish to show a very simple apparatus, with which you can easily repeat for yourselves many of the experiments made to-night, as well as add greatly to their number. It consists merely of a plate of window-glass, of good quality, set up on edge, and fastened on a blackened board (Fig. 7). If the

FIG. 7.

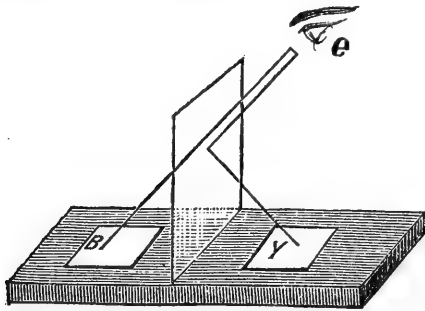

eye is placed at *e*, light will come to it directly from the blue square of paper, *B*, but also at the same time light will reach it from the yellow square of paper, *Y*; and these two masses of colored light, being mingled on the retina of the eye, will produce the same effects which I have just exhibited to you with much more costly apparatus. You will also find that you can vary the brightness of either of your squares by adjusting them at a greater or less distance from the plate of glass. When they are near to it, the yellow will predominate; the blue, when they are farther from it. Great use was made by Helmholtz of this contrivance in his experiments on this subject, and you will easily be able to prove for yourselves that the red light from paper painted with vermilion, when combined with the green light from the water-colored pigment known as "emerald-green," gives a yellowish or orange tint, according as the apparatus is arranged. Chrome-yellow (the pale variety) and ultramarine-blue give an excellent white. It is somewhat difficult to obtain a good representative of violet from among the colors in use by artists. I find that some samples of the dyeing material known as "Hoffmann's violet BB" answer better than any of the ordinary pigments. If a deep tint of its alcoholic solution be spread over paper, and combined in the instrument with emerald-green, a blue, greenish-blue, or violet-blue, can be readily produced. It is evident that a multitude of experiments of this character can be made, the number of colors united at one time being limited to two. For certain purposes I have modified the apparatus so that three tints can be combined. A second plate of glass is added at *P*, Fig. 8; this allows the compound beam of light from the first

plate to pass, but in addition it reflects to the eye a beam of light from a third slip of colored paper at *V*; and, by revolving the second glass plate slightly, the intensity of the third beam is easily regulated. This arrangement can be used to produce white light, by the mixture of three colors, for example, vermilion, emerald-green, and the violet just mentioned.

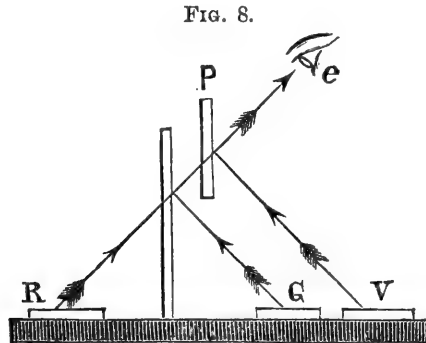

Let us pass, in the next place, to the consideration of another class of facts, which have an important bearing on our subject. If you illuminate some such object as a sheet of paper with a very moderate light, then, upon doubling the amount of light falling on it, it is possible that the paper, in the second case, may appear to you twice as bright as it did at first. But, if this process be for some time continued, you will soon come to a point where doubling the actual illumination produces very little effect, and finally a stage will be reached where a very great increase of actual illumination produces no additional effect on the eye at all, your paper looking no brighter than in a much feebler light. Let me make an experiment, to at least partially illustrate this: We have now upon the screen four large squares of white light, and they are, as you see, all of equal brightness. But, by turning this Iceland-spar prism, I superimpose one of the squares upon its neighbor; the central square now seems rather brighter than its companions, but I think no one in this room would suspect that its actual illumination was *twice* as great as that of the others. To take a still more striking example out of your own experience: you have often noticed the reflection of the gas-flames in the streets against the four panes of glass used to protect them, and have seen that the real flame looks brighter than the reflected one; but who would suppose that its actual luminosity was more than eleven times greater than that of its companion? In point of fact, sensation does not, for the most part, increase as rapidly as the actual intensity of the light exciting it, and a point can finally be reached where sensation does not increase at all, even though the actual brightness of the light is greatly multiplied. Our nervous organization is, in this direction, limited and finite, just as it is in all others.

The next matter to which your attention is called is really allied



to the preceding, though, at first sight, the connection is not very evident. Any color, if very luminous, seems paler than it really is. This simple piece of apparatus, where a bat-wing gas-flame is placed between a sheet of card-board and a plate of stained glass, will serve for experimental demonstration. The glass is red, and the paper seen through it appears of a deep-red hue, but the gas-flame itself, being much more luminous than the paper, does not look red at all; its tint is orange (Fig. 9). Replacing the red glass by green,

FIG. 9.

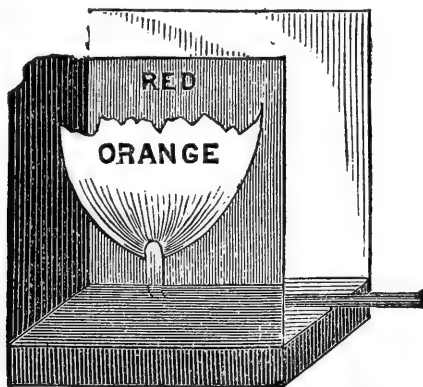

we have the paper appearing with a deep-green hue, while the flame seems greenish-yellow. Let us see if we can explain these curious changes of tint by Young's theory. The red glass used in the first experiment transmits to the eye only red light, or light capable of stimulating mainly the red nerves; but, if we increase its intensity beyond a certain point, its action on the red nerves begins to flag, and we soon have a state of things where a further increase of the red light produces no effect at all on the red nerves, they being already stimulated up to the maximum point. But, according to our theory, this red light has all along been acting, to some extent, on the green, and to a less extent on the violet nerves; and, as we add to its intensity, it acts still more powerfully on them, so that especially the green nerves come more and more into play, and a green is added to the original red sensations; the result, of course, is the sensation of orange.

The explanation of the tint obtained in the other experiment is quite similar. The green nerves are first stimulated up to their maximum point by green light of a certain strength, a further increase of its intensity brings into play the other two sets of nerves, particularly the red, and the tint quite naturally becomes greenish-yellow. You remember that, in a previous experiment, we found that a mixture of much green with a little red light gave a greenish-yellow. The nerves for violet light always lag behind the others, as will afterward be shown by a particular experiment.

The general effect, then, of a very bright illumination on natural objects is to cause their colors to appear paler than they otherwise

would. This is, indeed, to the painter, a precious resource, for representing, in his pictures, high degrees of luminosity, and is often employed with most happy effect. According to the careful experiments by Aubert, white paper is only fifty-seven times lighter than black paper, and the painter is in the predicament of being obliged to represent the vast range of natural illumination within these very narrow limits; hence the desirability of employing an artifice of this kind to overcome a difficulty which, if fairly met, would prove insuperable.

The considerations that I have just presented explain to us, quite readily, the curious circumstance that light of any color, if very bright, is at last accepted by the eye for white, all three sets of nerves finally reaching, in the order indicated, their point of maximum stimulation. You can repeat for yourselves a simple experiment of Helmholtz's, in this connection: hold before the eyes, for some little time, a plate of stained glass; the color may be red, yellow, blue, or green; after a while you will come to consider the brightest objects in your field of view white; as, for example, a gas-flame, the sky, or white paper. In point of fact, to be quite frank, white is only a relative sensation, and, if any thing like equality of stimulation is produced in the three sets of nerves, we finally accept the tint for white. I have especially arranged an experiment to illustrate this point: We have now upon the screen two large squares of light; one is deep red, the other green: I remove from the lantern a large plate of green glass; the red square has retained its color, and is now brighter, but the other square has become white or almost white. On removing the red glass, the red square on the screen is replaced by a white one, and we now for the first time see that its companion, which a moment ago we were ready to take for white, has a decidedly green hue; in fact, all the while the light producing it has been passing through a plate of pale-green glass, which was behind the others. Let me take away this plate, and now at last we have both our squares illuminated with pure white light. Is this light really white? Not at all; it has been tinged decidedly yellow, by passing through a pale-yellow glass, which has been concealed in the apparatus all the time as a reserve, and, on removing this glass, we find that the light we were ready to accept for white looks yellow, when compared with the purer light of the lantern. Finally, if we could throw a sample of daylight on the screen, we should again see that the light of the lantern itself is not white, but yellowish. White is evidently only a relative sensation.

In some of the preceding experiments it has been seen that, as we increase the actual brightness of any colored light, red for example, so does the sensation produced also increase, but usually at a slower rate. Now, it happens that some of the sensations increase more rapidly than others; for example, the sensation for red or yellow increases

more rapidly than that for blue or violet. In fact, as I said some time ago, the violet nerves always lag behind. From this it happens that, if we place side by side a quantity of blue and red light, arranging matters meanwhile so that they appear to the eye to be of equal brightness, then, upon adding considerably but equally to their actual luminosity, it will turn out that the red light will quite outstrip in apparent brilliancy its rival. We have now two such squares of red and blue, side by side on the screen, and it is difficult to say which is the brighter; but, when I greatly increase their illumination, it becomes evident that the blue one has been beaten; or, better still, when I reverse the experiment, starting with red and blue squares, of equal and considerable brilliancy, then, upon turning down the light of the lantern, and rendering them both dark, the blue square remains visible after its red companion has vanished. As another example, I may mention the blue color of the sky, which still continues plainly perceptible at night, when the illumination is so feeble that other colors have disappeared. Dove has pointed out that, in picture-galleries, as the light of day fades out, the blue colors in draperies and skies retain their power longer than the reds and yellows.

It is owing to this circumstance that, in actual landscapes, seen under the comparatively feeble light of the moon, there is a prevailing tendency to blueness. This also explains the circumstance that a landscape, illuminated by bright white clouds, appears more yellow in general hue than when the clouds are not bright, though still retaining their whiteness, the strong white light stimulating more powerfully the sets of nerves concerned in the production of yellow. I think we all know that, on dark, dull days, there seems to be a tendency to blueness in the coloring, even though we may not have paid much attention to the reverse phenomenon. All this is prettily illustrated by a very simple experiment of Helmholtz's, who noticed that the impression of a bright day was produced by merely holding a pale-yellow glass before his eyes, the tint of the glass being so faint as hardly to disturb the natural colors of the objects; the use of a very pale-blue glass seemed, on the other hand, to darken up the landscape, as though a cloud were passing over the scene.



## ELECTRIC SIGNALING ON ENGLISH RAILROADS.

By C. E. PASCOE.

**I** TAKE it for granted that most Americans who have traveled in England know of, if they don't actually know, Clapham Junction. It is a marvelous place is that Clapham Junction—a half-dozen or more naked-looking graveled platforms, destitute of almost every con-

venience in the shape of waiting and refreshment rooms, forming altogether one of the most important, not to say intricate, railway-depots in the United Kingdom. One arrives at a platform by a train belonging to one company going in one direction, and by turning right about, or walking three yards on the same platform, one may secure a seat in another train belonging to an entirely different company going no one knows whither. Once give way, or lose your head at this particular junction, and you may find yourself, should you happen to be wanting to go to the west of England, suddenly whirled away to the south, and *vice versa*. Even your traveling Londoner has an instinctive dread of "*the Junction*," as he familiarly terms it. Should you ever take up that indispensable requisite of English traveling, a Bradshaw, and stumble upon Clapham Junction in the list of stations your train is timed to stop at, go no farther. Don't tempt Fate. Rather court resignation. Throw yourself upon the cushions of your carriage, pitch Bradshaw out of the window, and in a moment of leisure work out this sum: If upon the average eight hundred trains (to say nothing of specials, excursions, and stray locomotives) pass through Clapham Junction in the course of twenty-four hours, allowing just about two minutes' interval of time between train A going out and train B coming in, what should be the chances of train B dashing into the tail of train A?

So remote as scarcely to be thought of, the reason being that the "block" system is in full force. What is this "block" system? To endeavor to answer that inquiry is the very object of this article.

To understand thoroughly what railway traveling in England really means, one should bear in mind a few facts now given for the purposes of this article, in the order of their importance.

At the beginning of last year there were in the United Kingdom about 15,500 miles of railway, distributed as follows: England and Wales, 11,000 miles; Scotland, 2,500 miles; Ireland, 2,000 miles; and 290 companies shared these miles of railroad between them. The total number of depots, or stations, as they are termed in England, including junctions and sidings, is about 10,000 for the whole kingdom; of these 6,000 are passenger-stations, giving approximately one station to about every two miles of railway, but not in reality, because there are no less than 150 stations in London and the suburbs alone. As a matter of course the great centre of the railway system of the United Kingdom is London. Every company which can by any possible means find a way to the capital does so, and strives to provide the route which will be most attractive to the public. To do this the majority of the companies must, of necessity, make use of the lines of the great companies having their termini in London. Only imagine the number of branch lines, junctions, and sidings, this must involve; what "shunting" of trains and adjusting of points there must be; what an efficient system of signaling must be required; what care,

steadiness, and application to work must be demanded of the men who look after the signals and points at the branch lines, junctions, and sidings. Take the Great Western line of England, for instance, with its 1,387 miles of road. Besides its own system, it falls in with the principal systems of the Bristol and Exeter, South Devon, North Wales, and ever so many more minor systems for the traffic of which it has in a measure, of course, to provide as well as for its own. Over all these lines trains are traveling daily at express speed, their ultimate destination being London. Now, express speed in England means an average rate of  $47\frac{3}{4}$  miles an hour, a pace which is probably greater by ten miles than that attained on any other railroads in the world. Indeed, on the Great Western and Great Northern lines even this rate of traveling is exceeded. On the first-mentioned system a train runs  $77\frac{1}{4}$  miles (from London to Swindon) without stopping, in 87 minutes, giving a uniform pace of  $53\frac{1}{4}$  miles an hour: on the Great Northern a train completes the journey from London to Peterborough ( $76\frac{1}{4}$  miles) in 90 minutes. Just one little error on the part of the signal man, one omission to adjust the points on the part of his mate, and down swoops the express on to the wrong line, and the result is an appalling catastrophe such as happened at Wigan the other day.

In the above little sum, which I suggested to be worked out, I mentioned that about 800 trains passed through Clapham Junction regularly every day. You take your stand upon the platform. Whish-h-h—Bang—Rattle—a train has passed you. Take out your watch, mark the second-hand going round, and before it gets to 60—Whish-h-h—Bang—Plunge—a second train has rushed out into the open, to catch the first one up. But it can't. The line is blocked by the sharp-sighted man in the signal-box yonder, who has no fear even if a train per minute were to work through. He has nothing to do with time. His duties are to maintain a certain and invariable interval of space between two trains, and he does it. How does he do it? If the reader will be good enough to follow me into the signal-box, he shall see.

Not much of a place certainly. On the whole rather like a second-rate sea-shore shanty, stuck upon four posts, so placed it seems that every train going into the station, and every train coming out from it, shall rush full tilt against the box and smash it and its occupants to atoms. In reality, the signal-box is so situated to command for a certain distance a full view of one line just where it joins to another. Interiorly our box is not unlike an unfurnished private box at a theatre, into which some of the machinist's properties have been put by mistake. Regarding a printed notice on the wall that strangers are particularly requested not to distract the attention of the signal-man from his duties, we take a look round, and the general impression to be got from a cursory glance is that it must be rather jolly to be a signal-man. Every thing looks so clean and neat; there is plenty of excitement to be had in watching the trains from the win-

dow ; the work does not appear to be very laborious, and what there is of it (which, truth to tell, is a great deal) would seem to be especially interesting and not unconnected with the gaining a full and accurate knowledge of the working of the electric telegraph. On the left-hand wall of the box as you enter, and on a level with the eye, are a number of little ebony handles, technically known as "keys," but variously termed in English railroad parlance "piston-keys" or "plungers." They are on the principle of the little "pea" bell fitted to the bedrooms of most large American hotels, and communicate telegraphically between the stations—"up" and "down." Over each of these "plungers" is an electric bell, which rings to give notice of the approach and departure of a train, its nature—that is, whether it is a passenger or goods, express or special—and to which company it belongs, when two or more companies have running powers over the same line. The custom universally adopted by English railroad companies to distinguish trains, and I believe it is the case with our own, too, in addition to the particular disks and lights carried upon the buffer-plank of the locomotive, is to blow the whistle a certain number of times when approaching a junction or station. The same system is adopted with the electric signals in the signal-box, only, in place of blowing the whistle, a bell is sounded. Every depression of the "plunger" transmits a current of electricity to the other station "up" or "down," as the case may be, which there sounds a bell or gong, and by varying the number of currents sent a code of signals is formed. For instance :

1	Depression of the "key" .....	Acknowledgment.
2	Depressions.....	Passenger-train.
3	" .....	Goods.
4	" .....	Special.
5	" .....	Obstruction-signal,

and so on. This code may, of course, be varied at pleasure ; and it is possible to give fifteen distinct and unmistakable signals upon a bell by varying the number of beats and repetitions. By means of these bells, then, a perfect means of communication is kept up between two stations, signal-boxes, or gate-houses, on a railroad.

The fundamental principle of the "block" system which we are now endeavoring to explain is, that no train traveling in the same direction shall ever approach nearer to another than the distances which the signal-men's boxes are apart. These distances vary on English roads according to circumstances, but, so long as the signals are properly made by the signal-man, and attended to by the driver of the locomotive, it becomes simply impossible for one train to run into another. For sake of illustration, let us take three signal-boxes, which we shall call B, and C, and D, on a line of railroad between B and E. We will suppose that the express from a station A has arrived at B,



and is about to proceed on its journey to E, and that an ordinary train has preceded it a quarter of an hour, which would allow about time enough for it to "shunt" or go off into the siding at D. When the train has passed the signal-box at C, the signal-man there telegraphs to the one at B that the line is clear, which means that there is no train on the "up" line between stations B and C. Directly the express referred to arrives at B, the signal-man there, if he has received the signal "all clear," allows the train to pass him, and at once telegraphs to C that there is a train on the "up" line. The C signal-man, if he has received a signal from D of line clear, allows the express to pass him also, but, if not, he exhibits his signal accordingly. We will now suppose that the express is yet between B and C, and that another train, approaching in the same direction, whistles to the man at B for leave to go on. This is refused until the C signal-man telegraphs that the line is clear. The same plan is carried out at every signal-box the train has to pass, of whatever nature it may be, whether "express," running at the rate of fifty-five miles an hour, or "goods," steaming along easily at a pace of twenty-five. It will thus be seen that, however great the traffic, it can be conducted with almost absolute safety, the only difference being that, with a very large number of trains per hour, the signal-boxes are placed nearer together, as on the Metropolitan or Underground Railroad of London, which has as near as possible one thousand trains passing over its system in the course of every twenty-four hours. No accident of any importance has ever occurred on this line.

But there are other objects in our signal-box besides plungers and little bells to attract attention. Four very noticeable toys—I use the term advisedly, for they struck me at once as being particularly suggestive of liliputian railroads, and dolls' houses, and toy signal-men—are the miniature electric semaphores used for instructing the signal-man as to setting the semaphore-signals on the line for the guidance of drivers of locomotives. Having stated the principle of the "block" system to be that no two following trains are to be allowed to proceed in the same direction upon the same section of line at the same time, it follows that a danger-signal must be exhibited and maintained at the station or depot from which a train has departed until it has been cleared out of the section of the line over which it is traveling. To do this effectually necessitates that this signal should be under the control of the signal-man toward whom the train is approaching; and no accident, mechanical or electrical, should be allowed to remove this signal until the train has arrived. The signals used on most of the English lines of railroad to guide the driver are, the raising and lowering of a semaphore arm to denote "danger" and "all clear." If it were possible to work these huge out-door signals by electricity, the system would be perfect; but, inasmuch as the power of electricity is circumscribed, the production of force sufficient

to actuate, with any degree of certainty, these exposed signals, has not yet been attained. It has become necessary, therefore, to rely upon small electrical instruments, miniatures of the out-door semaphores, which direct the signal-man in the box how to exhibit his out-door signals by displaying the signals which they themselves ought to give. The same principle which produces a blow upon the bell-signal lowers the semaphore arm on the miniature to "all clear." A current of electricity, flowing through the wire of an electro-magnet, converts the iron core into a magnet, and exerts precisely the same action upon a rocking lever that a pull or strain of a signal-wire does upon the large rocking lever of a signal-post. A counter-weight, when the current ceases, restores the arm to "danger," as it does in ordinary railroad-signals. So that the miniature semaphore will remain at "all clear" so long as a current flows, but, the moment the current ceases, the arm by the action of gravity flies up to "danger." It is impossible to lower the signal at one station except by the action of an electric current, and to maintain that signal at "all clear" except by the persistent effect of the battery at the other station. The signal, therefore, is under the sole control of the signal-man toward whom the train is approaching. The instrument employed to raise and lower this miniature signal is called a "switch," from the similarity of its appearance and construction to the switch-handles or levers employed to raise and lower the larger signals on the line. Its electrical construction is precisely similar to that of the "plunger." By removing the handle over from one side to the other, it places the battery in connection with the line wire, and thereby causes a current of electricity to flow which lowers the signal.

There were four of these miniature "switches" in our signal-box, and this was the way they appeared to us to work: When the switch-handle was placed so as to be nearest us, or On, no current was transmitted, and the little signal stood at "*danger*;" when, however, it was pushed over farthest from us to Off, a current flowed, and the little arm was lowered to "all clear." As the arm could only be lowered when a current was flowing, it was only when the switch-handle was pushed over to Off that the "all-clear" signal could be given. Similarly, when the switch-handle was at On, the flow of electricity at once ceased, and the signal flew to "danger." The signal "all clear" could therefore only be given when the little switch was intentionally placed over to Off, and there was no other means of accomplishing this object by willfulness or accident. No accident, mechanical or electrical, could alter the miniature danger-signal. The man at our signal-box had the sole and complete control over the signal at the next box, and it was simply impossible for him to interfere with or alter the signal in his own box. This in effect is the "block" system, which answers so admirably on the principal lines of English railroad. The instructions given to signal-men who work the signals

we have been describing are as follows, and we give them that the reader, when next traveling upon an English line of railroad and passing a signal-box, may give a passing thought of thanks to the inventor of the "block" system, and the gentleman who framed these rules, Mr. William Henry Preece, of the Institute of Civil Engineers, and to the individual, let us hope, who follows them closely—the signal-man :

INSTRUCTIONS.

1. No train or engine is to be allowed to pass your box unless the electric signal for the section into which it is about to proceed stands at ALL CLEAR.

2. When a train has entered the section of line which you have protected (under Rule 4), you will signal to the next station, two beats on the bell *twice*, to signify "Train coming; be ready."

3. On the approach or arrival of the train or engine at your box, you will, provided the electric signal stands at ALL CLEAR, at once signal it on the bell to the next station in advance, thus :

If a passenger-train . . by 2 beats.  
 " goods-train . . . . . " 3 "  
 " special or engine. " 4 "

4. This signal will be acknowledged by the corresponding station, by throwing his switch-handle over to "on," thereby placing the electric signal at your station at DANGER, and protecting the line from any train following that already in the section.

5. You will acknowledge this signal by returning one beat of the bell.

6. On the arrival of the  $\left\{ \begin{array}{c} \text{Down} \\ \text{Up} \end{array} \right\}$  train at  $\left\{ \begin{array}{c} \text{ } \\ \text{ } \end{array} \right\}$ , the signal-man at that station will pull his switch-handle over to OFF, thereby removing your danger-signal, intimating the arrival of the train and clearing the line.

7. This you will acknowledge by one beat on the bell.

8. In case any obstruction exists upon the line to necessitate its being blocked, give five sharp beats on the bell (which must be repeated), and raise the electric signal to *Danger*, which must be maintained as long as the obstruction lasts.

9. No signal is to be considered complete until it has been acknowledged.

I beg leave to state that this article is written without being at all acquainted with the system of signaling on American lines of railroad, so that I am unable to say how far our own bears comparison with the English system.



THE FACIAL ANGLE.

BY RANSOM DEXTER, A. M., M. D.,

PROFESSOR OF ZOOLOGY AND PHYSIOLOGY IN THE UNIVERSITY OF CHICAGO.

THE methods of estimating the facial angle hitherto adopted by naturalists are all mere modifications of that proposed by Peter Camper, and consist in describing an angle with one line passing along the base of the skull, intersected by another which passes from the anterior portion of the upper jaw over the forehead.

Prof. Owen's definition is : "If a line be drawn from the occipital condyle along the floor of the nostrils, and be intersected by a second,

touching the most prominent parts of the forehead and upper jaw, the intersected angle is called the facial angle" (vol. ii., p. 572, "Anatomy of Vertebrates").

The relation of the face is not to the base of the skull, or the plane from the floor of the nostrils to its articulation to the backbone, but to the axis of the body; for the face, in the lowest class of animals that have a backbone, the fish, is in line with the base of the skull, the axis of the body, and the dorsal surface of the animal; and in man, the highest class, the face is in line with the abdominal surface, and axis of the body. But the base of the skull does not keep in harmony, but varies irregularly. Then, there are numerous *other* elements than the bones at the base of the skull, that are factors in the aspect of the face, as, the modified development of other bones of the skull, peculiar development of bones of the face, and relation of the bones of the face that are *not* attached to the *skull*, but to other *facial bones*.

To make the subject more clearly comprehensible, it will be necessary to trace more in detail the development of the division of animals to be considered.

The subject of the facial angle has occupied the attention of philosophers from the earliest antiquity. Their theories, though vague, unsatisfactory, and uninteresting in themselves, yet tend conclusively to show that some patent general principle underlies the whole domain of the subject. Confined, as they were, to the narrow limits of the varieties of the human race, they would get only a part of the evidence that is so beautifully illustrated, when we include the whole sub-kingdom of animals to which we belong.

At the beginning of the present century, Cuvier, Von Baer, and others, discovered and established the great laws of evolution. The laws thus elucidated were: 1. That the entire animal kingdom originates from an ancestral egg; eggs, too, though differing in physical appearance, that are quite similar in structure. 2. That every animal, in its evolution, had to pass through the several stages of ovulation, fertilization, germination, and development, before it could maintain an independent existence. 3. That in their development they assumed but few primary structural patterns or types.

After the promulgation of the above doctrines, a series of investigations ensued, which brought naturalists to approximate a general agreement that there are only five general morphological or form-types of animals. Every animal, then, of the entire animal kingdom, must be classed in one or the other of these five sub-kingdoms, and each division thus classed has one fundamental plan of structure. The only way in which the animals of each sub-kingdom can differ is in the manner of executing their physiological functions.

In considering, then, any of the great physiological and philosophical questions that are based upon a uniformity of primitive type-development, we find that many useful lessons may be learned by including

in our considerations every class of animals in which the specialization to be considered appears. For example, every animal belonging to the vertebrate sub-kingdom of animals agrees with every other animal of the same sub-kingdom in the following distinctive characteristics—characteristics, too, that we shall find involved in our considerations of the subject of the facial angle: In all, the head and vertebral column are composed of a number of definite segments, arranged along a longi-

FIG. 1.

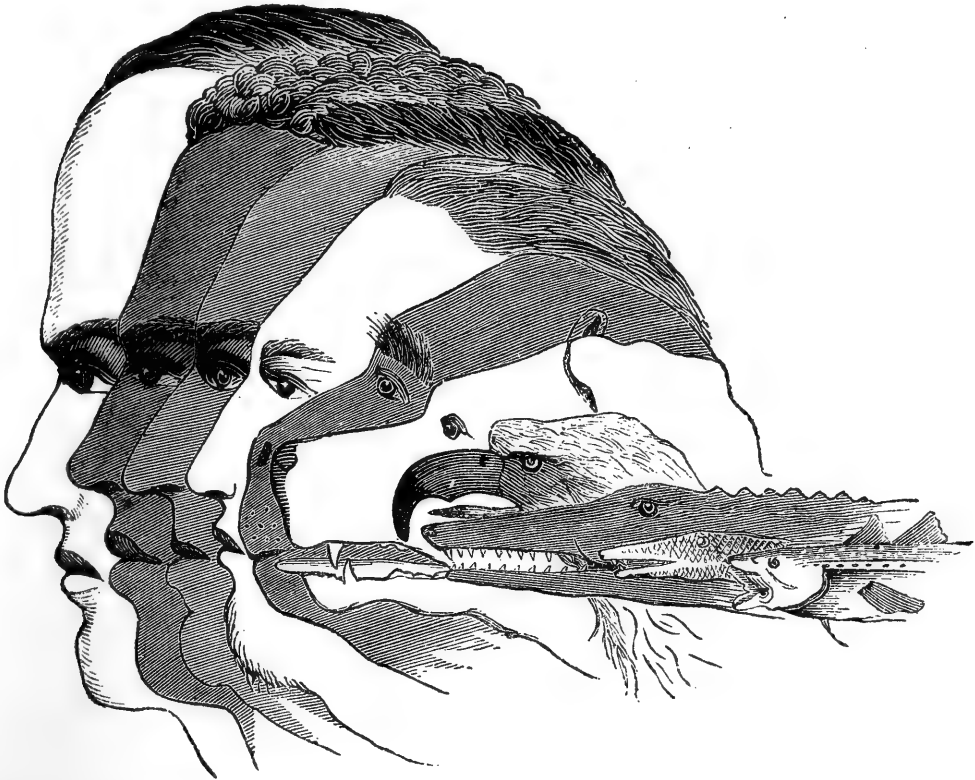

tudinal axis; each segment of this framework is normally composed of a body and two diverging, ring-like formations; the dorsal containing the brain and spinal cord, the ventral, or abdominal, containing the organs of nutrition, as the alimentary canal, circulating and eliminating organs. Every vertebrate animal, then, is possessed of two tubes of framework: the one, to protect the brain and spinal cord; the other, the organs of nutrition. These tubes are subject to very great variation, and are modified, as by a master's hand, to meet the necessities that their various specializations of function may demand. The great modification in the calibre of the dorsal tube in different classes of the vertebrates, as well as the great variation in shape of the elements which compose that arch, is apparent to every one. In the region of the spine, the elements that compose the segments of the arch are rounded, and at some distance apart, while in the *cranial* (skull) region they are flattened, spread out, so as to unite and form sutures, thus making a solid brain-case, for the protection of the softer and more massive nerve-matter.

The elements composing the nutritive case are the jaws, ribs, and pelvic girdle. These, like the spinal elements, are subject to great modification, owing to the immense range of variation to which their specializations are subjected. The difference in the facial develop-

FIG. 2.

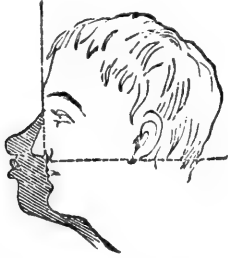
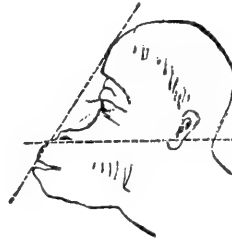

FIG. 3.



ments can well be imagined by calling to mind the various countenances of animals, from the fish to man. The angle of the face is simply and properly, I think, indicated by the relation expressed by two lines: the first, or base line, corresponding to the axis of the body; the other, diverging, or face line, drawn from the anterior margin of the upper jaw, over the centre of the forehead. The relation and angles formed by these two lines, and their intersections thus indicated, express the relation and comparative development at the union of the two primitive tubes, the *neural*, or skull, and *hemal* (face), at the anterior extremity or head of a vertebrate animal.

As before stated, authors have hitherto established the base-line from the floor of the nostrils, to the articulation of the occipital bone to the vertebræ. This is a grave error, and one, no doubt, that has contributed its share to depreciate the subject as an index to the mental caste of a vertebrate animal. For, by adopting this method, we are subject to the enormous error of ninety degrees in passing through the sub-kingdom, all of which we lose, little by little, as we ascend the scale of animals of this type, or form of structure. And yet they make this application through the entire vertebrate series. Yet, by referring to the cut, we find the face of the lowest class of the type, the fish, to be in direct line with the dorsal surface of the animal, and hence the base and diverging lines are parallel; while, in the highest of the type, that of man, the face is in line with the ventral or abdominal surface. Again, after effecting a grand variation of one hundred and eighty degrees, or the half of a circle, the two lines are once more parallel.

What, then, are the factors in the phenomena of the great change of the aspect of the face, with such a modification of its constituents, from a line of the dorsal to that of the abdominal surface, all of which is effected by almost imperceptible gradations, as we ascend the series from the fish to man? It is by the modification of the anterior extremities of these cranio-vertebral canals in the development and increase of the cerebral hemispheres, which is that part of the brain that is recognized as the seat of thought, and their influence upon other



structures, that the whole change is wrought from a complete dominant power of the physical over the mental, to the reverse, viz., an entire dominant ascension, in some instances, of the *moral and intellectual* over the physical. *In every vertebrate animal, then, there are two factors, the physical and mental; the facial angle is the typical expression or exponent of the relative strength or condition of each.*

It may be observed that, with the ascension of these animals, the relative size of the brain-case, or skull, increases with a proportionate diminution of the bones of the face, and of the projection of the jaws in front of the orbits.

In the cold-blooded fish, the serpent, and the crocodile, the cavity for the brain is small, but little more than a prolongation of the canal for the spinal cord, with a disproportionate development of the organs of mastication, thus enabling them to execute the strongest instinct of the lower animals, namely, to slay and devour. In the bird class, the brain is somewhat larger, but is contained in the posterior part of the cranium, they manifesting but a slight mental superiority over the reptile. In the dog, over whom man is lord, and the noble horse, the brain is much larger; the facial line intersects at about a right angle with the base line, or vertebral axis. In these animals we begin to discover the rudiments of some of those more noble motives which are so abundantly lavished upon *some* of the higher animals.

The monkey and the anthropoid, or man-like apes, express in a very characteristic manner many of the mental attributes of the lower varieties of the human species. Nor is this to be wondered at, when we consider the close anatomical relation which subsists between the two, and the enormous development of the cerebral hemispheres as compared with the lower classes of the same type.

The profile of the idiot is the next introduced in the cut, to illustrate the influence upon the size and shape of the *cranium*, or skull, that an arrest of brain-development has wrought, and which corresponds to the mental manifestations of its subject.

The other three profile views represent the savage, the half-civilized, and the *cultivated* races of man. The first of the three, the one next to the view of the idiot, is a drawing from a correct engraving of the celebrated North American Indian chief Black Hawk, and corresponds in brain capacity, facial angle, and mental powers, very nearly to the other savage races, viz., the Malayan and Ethiopian. The next that is represented in the cut is the half-civilized Mongolian race, illustrating very nicely the ratio of the two factors, physical and mental. The last is a representation of the highly-cultivated Caucasian race, and is a correct profile view of one of the most illustrious statesmen that this or any other nation ever possessed—that of Daniel Webster.

In the lowest of the type, the fish, we find the brain least developed, and the cerebral hemispheres, or instrument of thought, bearing

the smallest proportion, either to its own concomitant structures, or to the rest of the body. The actual weight of a common codfish was 14,875 grains; the brain weighed only  $9\frac{1}{2}$  grains; thus making the ratio of 1 to 1,565. In man, the average weight of the brain is about 3 pounds, the medium weight of the body 150 pounds, making a ratio of 1 to 50. The above is a correct statement of the relative weight of the brain to the body of the lowest of the type, the fish, and the highest, man; showing the ratio of the weight of the brain in man, to that of the body, to be over 31 times greater than the same ratio in the fish. But, if we estimate the proportionate weight of merely the *cerebral hemispheres*, or the instruments of thought, to that of the body in the fish and man, we obtain a difference of 124, which expresses the number of times the cerebral hemispheres of man are greater than those of the fish; in other words, if the body of a fish and that of man were of equal weight, the cerebral hemispheres of the latter would weigh 124 times more than those of the former. Further, the relative weight of the cerebral hemispheres, as we ascend from the fish through the vertebrate sub-kingdom of animals, will be found to correspond to the variation of the face-line from a parallel with the dorsal surface.

To recapitulate: 1. The size and weight of the brain will be found to increase with the angle of the face to the axis of the body. 2. The expansion of the brain-case, with a proportionate diminution of the facial bones, is an invariable accompaniment of an increased facial angle throughout the vertebrate sub-kingdom of animals. 3. The mental manifestation and power have a direct relation to the angle above indicated. 4. The position assumed by the body of the animal in its change from the horizontal to the perpendicular attitude, also very generally agrees with the facial angle of its subject. 5. The projection of the jaws, in front of the ocular orbits, is also a correlative index to the above data. 6. The relative ascendancy of the two factors, the physical and mental, with their numerous phenomena, is an index to all of the above relations, and shows very conclusively the gradual turning from the lowest instincts of the brute to the most complex mental powers of man.



## DISPOSAL OF THE DEAD.

BY SIR HENRY THOMPSON,

PROFESSOR OF CLINICAL SURGERY IN UNIVERSITY COLLEGE, LONDON.

**A**FTER Death! The last faint breath had been noted, and another watched for so long, but in vain. The body lies there, pale and motionless, except only that the jaw sinks slowly but perceptibly. The pallor visibly increases, becomes more leaden in hue,

and the profound, tranquil sleep of Death reigns where just now were life and movement. Here, then, begins the eternal rest.

Rest! no, not for an instant. Never was there greater activity than at this moment exists in that still corpse. Activity, but of a different kind to that which was before. Already a thousand changes have commenced. Forces innumerable have attacked the dead. The rapidity of the vulture, with its keen scent for animal decay, is nothing to that of Nature's ceaseless agents now at full work before us. That marvelously complex machine, but this moment the theatre of phenomena too subtle and too recondite to be comprehended; denotable only by phraseology which stands for the unknown and incomputable—vital, because more than physical, more than chemical—is now consigned to the action of physical and chemical agencies alone. And these all operating in a direction the reverse of that which they held before death. A synthesis, then, developing the animal being. The stages of that synthesis, now, retraced, with another end, still formative, in view. Stages of decomposition, of decay, with its attendant putrescence; process abhorrent to the living, who therefore desire its removal. "Bury the dead out of my sight," is the wholly natural sentiment of the survivor.

But Nature does nothing without ample meaning; nothing without an object desirable in the interest of the body politic. It may, then, be useful to inquire what must of necessity happen if, instead of burying or attempting to preserve the dead, Nature follows an unimpeded course, and the lifeless animal is left to the action of laws in such case provided.

It is necessary first to state more exactly the conditions supposed to exist. Thus, the body must be exposed to air; and must not be consumed as prey by some living animal. If it is closely covered with earth or left in water, the same result is attained as in the condition first named, although the steps of the process may be dissimilar.

The problem which Nature sets herself to work in disposing of dead animal matter is always one and the same. The order of the universe requires its performance; no other end is possible. The problem may be slowly worked, or quickly worked; the end is always one.

It may be thus stated: The animal must be resolved into—

*a.* Carbonic acid ( $\text{CO}_2$ ), water ( $\text{HO}$ ), and ammonia ( $\text{NH}_3$ ).

*b.* Mineral constituents, more or less oxidized, elements of the earth's structure: lime, phosphorus, iron, sulphur, magnesia, etc.

The first group, gaseous in form, go into the atmosphere.

The second group, ponderous and solid, remain where the body lies, until dissolved and washed into the earth by rain.

Nature's object remains still unstated: the constant result of her work is before us; but wherefore are these changes? In her wonderful economy she must form and bountifully nourish her vegetable

progeny ; twin-brother life, to her, with that of animals. The perfect balance between plant existences and animal existences must always be maintained, while "matter" courses through the eternal circle, becoming each in turn.

To state this more intelligibly by illustration : If an animal be resolved into its ultimate constituents in a period according to the surrounding circumstances, say, of four hours, of four months, of four years, or even of four thousand years—for it is impossible to deny that there may be instances of all these periods during which the process has continued—those elements which assume the gaseous form mingle at once with the atmosphere, and are taken up from it without delay by the ever-open mouths of vegetable life. By a thousand pores in every leaf the carbonic acid which renders the atmosphere unfit for animal life is absorbed, the carbon being separated and assimilated to form the vegetable fibre, which, as wood, makes and furnishes our houses and ships, is burned for our warmth, or is stored up under pressure for coal. All this carbon has played its part, "and many parts," in its time, as animal existences from monad up to man. Our mahogany of to-day has been many negroes in its turn, and before the African existed was integral portions of many a generation of extinct species. And, when the table, which has borne so well some twenty thousand dinners, shall be broken up from pure debility and consigned to the fire, thence it will issue into the atmosphere once more as carbonic acid, again to be devoured by the nearest troop of hungry vegetables—green peas or cabbages in a London market-garden, say—to be daintily served on the table which now stands in that other table's place, and where they will speedily go to the making of "lords of the creation." And so on, again and again, as long as the world lasts.

Thus it is that an even balance is kept—demonstrable to the very last grain if we could only collect the data — between the total amounts of animal and of vegetable life existing together at any instant on our globe. There *must* be an unvarying relation between the decay of animal life and the food produced by that process for the elder twin, the vegetable world. Vegetables first, consumed by animals either directly or indirectly, as when they eat the flesh of animals who live on vegetables. Secondly, these animals daily casting off effete matters, and by decay after death providing the staple food for vegetation of every description. One the necessary complement of the other. The atmosphere, polluted by every animal whose breath is poison to every other animal, being every instant purified by plants, which, taking out the deadly carbonic acid and assimilating carbon, restore to the air its oxygen, first necessary of animal existence.

I suppose that these facts are known to most readers, but I require a clear statement of them here as preliminary to my next subject ; and in any case it can do no harm to reproduce a brief history of this mar-

velous and beautiful example of intimate relation between the two kingdoms.

I return to consider man's interference with the process in question just hinted at in the quotation, "Bury the dead out of my sight."

The process of decomposition affecting an animal body is one that has a disagreeable, injurious, often fatal influence on the living man if sufficiently exposed to it. Thousands of human lives have been cut short by the poison of slowly-decaying and often diseased animal matter. Even the putrefaction of some of the most insignificant animals has sufficed to destroy the noblest. To give an illustration which comes nearly home to some of us—the graveyard pollution of air and water alone has probably found a victim in some social circle known to more than one who may chance to read this paper. And I need hardly add that in times of pestilence its continuance has been often due mainly to the poisonous influence of the buried victims.

Man, then, throughout all historic periods, has got rid of his dead kin after some fashion. He has either hidden the body in a cave and closed the opening to protect its tenant from wild beasts, for the instinct of affection follows most naturally even the sadly-changed remains of our dearest relative; or, the same instinct has led him to embalm and preserve as much as may be so preservable—a delay only of Nature's certain work—or the body is buried beneath the earth's surface, in soil, in wood, in stone, or metal—each mode another contrivance to delay, but never to prevent, the inevitable change. Or, the body is burned, and so restored at once to its original elements, in which case Nature's work is hastened, her design anticipated, that is all. And, after burning, the ashes may be wholly or in part preserved in some receptacle in obedience to the instinct of the survivor, referred to above. All forms of sepulture come more or less under one of these heads.<sup>1</sup>

One of the many social questions waiting to be solved, and which must be solved at no very remote period, is, Which of these various forms of treatment of the dead is the best for survivors?

This question may be regarded from two points of view, both possessing importance, not equally perhaps; but neither can be ignored.

A. From the point of view of Utility; as to what is best for the entire community.

B. From the point of view of Sentiment; the sentiment of affectionate memory for the deceased, which is cherished by the survivor.

I assume that there is no point of view to be regarded as belonging to the deceased person, and that no one believes that the dead has any interest in the matter. We who live may anxiously hope—as I should hope at least—to do no evil to survivors after death, whatever

<sup>1</sup> "Burial at sea" is a form of exposure, the body being rapidly devoured by marine animals.

we may have done of harm to others during life. But, being deceased, I take it we can have no wishes or feelings touching this subject. What is best to be done with the dead is then mainly a question for the living, and to them it is one of extreme importance. When the globe was thinly-peopled, and when there were no large bodies of men living in close neighborhood, the subject was an inconsiderable one and could afford to wait, and might indeed be left for its solution to sentiment of any kind. But the rapid increase of population forces it into notice, and especially man's tendency to live in crowded cities. There is no necessity to prove, as the fact is too patent, that our present mode of treating the dead, namely, that by burial beneath the soil, is full of danger to the living. Hence intramural interment has been recently forbidden, first step in a series of reforms which must follow. At present we who dwell in towns are able to escape much evil by selecting a portion of ground distant—in this year of grace 1873—some five or ten miles from any very populous neighborhood, and by sending our dead to be buried there—laying by poison nevertheless, it is certain, for our children's children, who will find our remains polluting their water-sources, when that now distant plot is covered, as it will be, more or less closely by human dwellings. For it can be a question of time only when every now waste spot will be utilized for food-production or for shelter, and when some other mode of disposing of the dead than that of burial must be adopted. If, therefore, burial in the soil be certainly injurious either now or in the future, has not the time already come to discuss the possibility of replacing it by a better process? We cannot too soon cease to do evil and learn to do well. Is it not indeed a social sin of no small magnitude to sow the seeds of disease and death broadcast, caring only to be certain that they cannot do much harm to our own generation? It may be granted, to anticipate objection, that it is quite possible that the bodies now buried may have lost most, if not all, their power of doing mischief by the time that the particular soil they inhabit is turned up again to the sun's rays, although this is by no means certain; but it is beyond dispute that the margin of safety as to time grows narrower year by year, and that pollution of wells and streams which supply the living must ere long arise wherever we bury our dead in this country. Well, then, since every buried dead body enters sooner or later into the vegetable kingdom, why should we permit it, as it does in many cases, to cause an infinity of mischief during the long process?

Let us at this point glance at the economic view of the subject, for it is not so unimportant as, unconsidered, it may appear. For it is an economic subject whether we will it or not. No doubt a sentiment repugnant to any such view must arise in many minds, a sentiment altogether to be held in respect and sympathy. Be it so; the question remains strictly a question of prime necessity in the economic



system of a crowded country. Nature will have it so, whether we like it or not. She destines the material elements of my body to enter the vegetable world on purpose to supply another animal organism which takes my place. She wants me, and I *must* go. There is no help for it. When shall I follow—with quick obedience, or unwillingly, truant-like, traitor-like, to her and her grand design? Her capital is intended to bear good interest and to yield quick return; all her ways prove it—"increase and multiply" is her first and constant law. Shall her riches be hid in earth to corrupt and bear no present fruit, or be utilized, without loss of time, value, and interest, for the benefit of starving survivors? Nature hides no talent in a napkin; we, her unprofitable servants only, thwart her ways and delay the consummation of her will.

Is a practical illustration required? Nothing is easier. London was computed, by the census of 1871, to contain 3,254,260 persons, of whom 80,430 died within the year. I have come to the conclusion, after a very carefully-made estimate, that the amount of ashes and bone-earth—such as is derived by perfect combustion—belonging to and buried with those persons, is by weight about 206,820 pounds. The pecuniary value of this highly-concentrated form of animal solids is very considerable. For this bone-earth may be regarded as equivalent to at least six or seven times its weight of dried but unburned bones, as they ordinarily exist in commerce. The amount of other solid matters resolvable by burning into the gaseous food of plants, but rendered unavailable by burial for, say fifty or a hundred years or more, is about 5,584,000 pounds, the value of which is quite incalculable, but it is certainly enormous as compared with the preceding.

This is for the population of the metropolis only; that of the United Kingdom for the same year amounted to 31,483,700 persons, or nearly ten times the population of London. Taking into consideration a somewhat lower death-rate for the imperial average, it will at all events be quite within the limit of truthful statement to multiply the above quantities by nine in order to obtain the amount of valuable economic material annually diverted in the United Kingdom, for a long term of years, from its ultimate destiny by our present method of interment.

The necessary complement of this ceaseless waste of commodity most precious to organic life, and which must be replaced, or the population could not exist, is the purchase by this country of that same material from other countries less populous than our own, and which can, therefore, at present spare it. This we do to the amount of much more than half a million pounds sterling per annum.<sup>1</sup>

Few persons, I believe, have any notion that these importations

<sup>1</sup> Value of bones imported into the United Kingdom, of which by far the larger part is employed for manure, has been in 1866, £409,590; 1869, £600,029; 1872, £753,185.—*Statistical Abstract*, No. 20.—Spottiswoode, 1873.

of foreign bones are rendered absolutely necessary by the hoarding of our own some six feet below the surface. The former we acquire at a large cost for the original purchase and for freight. The latter we place, not in the upper soil where they would be utilized, but in the lower soil, where they are not merely useless, but where they often mingle with and pollute the streams which furnish our tables. And, in order to effect this absurd, if not wicked result, we incur a lavish expenditure! I refer, of course, to the enormous sums which are wasted in effecting burial according to our present custom, a part of the question which can by no means be passed over. For the funeral rites of the 80,000 in London last year, let a mean cost of ten pounds per head be accepted as an estimate which certainly does not err on the side of excess.<sup>1</sup> Eight hundred thousand pounds must therefore be added as absolute loss, to the costs already incurred in the maintenance of the system. Thus we pay every way and doubly for our folly.

What, then, is it proposed to substitute for this custom of burial? The answer is easy and simple. Do that which is done in all good work of every kind—follow Nature's indication, and do the work she does, but do it better and more rapidly. For example, in the human body she sometimes throws off a diseased portion in order to save life, by slow and clumsy efforts, it is true, and productive of much suffering; the surgeon performs the same task more rapidly and better, follows her lead, and improves on it. Nature's many agents, laden with power, the overaction of which is harmful, we cannot stop, but we tame, guide, and make them our most profitable servants. So here, also, let us follow her. The naturally slow and disagreeable process of decomposition which we have made by one mode of treatment infinitely more slow and not less repulsive, we can, by another mode of treatment, greatly shorten, and accomplish without offense to the living. What in this particular matter is naturally the work of weeks or months, can be perfectly done in an hour or two.

The problem to be worked is: Given a dead body, to resolve it into carbonic acid, water, and ammonia, and the mineral elements, rapidly, safely, and not unpleasantly.

The answer may be practically supplied in a properly-constructed furnace. The gases can be driven off without offensive odor—the

<sup>1</sup> Items comprised in the calculation :

1. Cost of shroud, coffin, labor of digging a grave—essential now in all burials.
2. Cost of funeral-carriages, horses, trappings, and accoutrements.

Ornamental coffins in wood and metal.

Vaults and monumental art—more or less employed in all funerals above the rank of pauper.

The cost of simple modes of transit is not included in the calculation, because necessary in any case, whatever the destination of the body. The above-named items are only necessary in the case of interment in a grave; and not one would be required, for example, in the case of cremation, or burning of the body.

mineral constituents will remain in a crucible. The gases will, ere night, be consumed by plants and trees. The ashes or any portion of them may be preserved in a funeral-urn, or may be scattered on the fields, which latter is their righteous destination. No scents or balsams are needed, as on Greek and Roman piles, to overcome the noxious effluvia of a corpse burned in open air. Modern science is equal to the task of thus removing the dead of a great city without instituting any form of nuisance; none such as those we tolerate everywhere from many factories, both to air and streams. Plans for the accomplishment of this have been considered; but discussion of the subject alone is aimed at here. To treat our dead after this fashion would return millions of capital without delay to the bosom of Mother Earth, who would give us back large returns at compound interest for the deposit.

Who can doubt now that the question is one of vital economy to the people of this country? This is still no reason why it should not be considered from the point of view of sentiment. And what has sentiment to urge on behalf of the present process? Let us see what the process is.

So far as I dare! for, could I paint, in its true colors, the ghastly picture of that which happens to the mortal remains of the dearest we have lost, the page would be too deeply stained for publication. I forbear, therefore, to trace the steps of the process which begins so soon and so painfully to manifest itself after that brief hour has passed, when "she lay beautiful in death." Such loveliness as that, I agree, it might be treason to destroy, could its existence be perpetuated, and did not Nature so ruthlessly and so rapidly blight her own handy-work, in furtherance of her own grand purpose. The sentiment of the survivor on behalf of preserving the beauty of form and expression, were it possible to do so, would, I confess, go far to neutralize the argument based on utility, powerful as it is. But a glimpse of the reality which we achieve by burial would annihilate, in an instant, every sentiment for continuing that process. Nay, more, it would arouse a powerful repugnance to the horrible notion that we too must some day become so vile and offensive, and, it may be, so dangerous; a repugnance surmountable only through the firm belief that after death the condition of the body is a matter of utter indifference to its dead life-tenant. Surely if we, the living, are to have sentiments, or to exercise any choice about the condition of our bodies after death, those sentiments and that choice must be in favor of a physical condition which cannot be thought of either as repulsive in itself or as injurious to others.

There is a source of very painful dread, as I have reason to know, little talked of, it is true, but keenly felt by many persons, at some time or another, the horror of which to some is inexpressible. It is the dread of premature burial; the fear lest some deep trance should be mistaken for death, and that the awakening should take place too

late. Happily, such occurrences must be exceedingly rare, especially in this country, where the interval between death and burial is considerable, and the fear is almost a groundless one. Still, the conviction that such a fate is possible, which cannot be altogether denied, will always be a source of severe trial to some. With cremation, no such catastrophe could ever occur; and the completeness of a properly conducted process would render death instantaneous and painless, if by an unhappy chance any individual so circumstanced were submitted to it. But the guarantee against this danger would be doubled, since inspection of the entire body must of necessity immediately precede the act of cremation, no such inspection being possible under the present system.

In order to meet a possible objection to the substitution of cremation for burial, let me observe that the former is equally susceptible with the latter of association with religious funereal rites, if not more so. Never could the solemn and touching words, "ashes to ashes, dust to dust," be more appropriately uttered than over a body about to be consigned to the furnace; while, with a view to metaphor, the dissipation of almost the whole body in the atmosphere, in the ethereal form of gaseous matter, is far more suggestive as a type of another and a brighter life, than the consignment of the body to the abhorred prison of the tomb.

I do not propose to describe here the processes which have been employed, or any improved system which might be adopted for the purpose of insuring rapid and perfect combustion of the body, although much might be said in reference to these matters. There is no doubt that further experiments and research are wanting for the practical improvement of the process, especially if required to be conducted on a large scale. Something has been already accomplished, and with excellent results. I refer to recent examples of the process as practised by Dr. L. Brunetti, Professor of Pathological Anatomy in the University of Padua. These were exhibited at the Exposition of Vienna, where I had the opportunity of examining them with care. Prof. Brunetti exposed the residue from bodies and parts of bodies on which he had practised cremation by different methods, and the results of his latest experience may be summarized as follows: The whole process of incineration of a human adult body occupied three and a half hours. The ashes and bone-earth weighed 1.70 kilogramme, about three pounds and three-quarters avoirdupois. They were of a delicate white, and were contained in a glass box about twelve inches long, by eight inches wide, and eight deep. The quantity of wood used to effect absolute and complete incineration may be estimated from its weight, about 150 pounds. He adds that "its cost was one florin and twenty kreuzers," about two shillings and fourpence English. The box was that marked No. IX. in the case, which was No. 4,149 in the catalogue: Italian.

In an adjacent case was an example of mummification, by the latest and most successful method. By a series of chemical processes it has been attempted to preserve in the corpse the appearance natural to life, as regards color and form. Admirable as the result appears to be, in preserving anatomical and pathological specimens of the body, it is, in my opinion, very far from successful when applied to the face and hand. At best, a condition is produced which resembles a badly-colored and not well-formed waxen image. And the consciousness that this imperfect achievement is the real person and not a likeness, so far from being calculated to enhance its value to the survivor, produces the very painful impression, as it were, of a debased original; while, moreover, it is impossible not to be aware that the substitution of such an image for the reality must in time replace the mental picture which exists, of the once living face lighted by emotion and intelligence, of which the preserved face is wholly destitute.

To return to the process of cremation. There are still numerous considerations in its favor which might be adduced, of which I shall mention only one; namely, the opportunity it offers of escape from the ghastly but costly ceremonial which mostly awaits our remains after death. How often have the slender shares of the widow and orphan been diminished in order to testify, and so unnecessarily, their loving memory of the deceased, by display of plumes and silken scarfs about the unconscious clay! And, again, how prolific of mischief to the living is the attendance at the burial-ground, with uncovered head, and damp-struck feet, in pitiless weather, at that chilling rite of sepulture! Not a few deaths have been clearly traceable to the act of offering that "last tribute of respect."

Perhaps no great change can be expected at present in the public opinions current, or rather in the conventional views which obtain, on the subject of burial, so ancient is the practice, and so closely associated is it with sentiments of affection and reverence for the deceased. To many persons, any kind of change in our treatment of the dead will be suggestive of sacrilegious interference, however remote, either in fact or by resemblance to it, such change may be. Millions still cherish deep emotions, connected both with the past and the future, in relation to the "Campo Santo," and the annual "Jour des Morts." And many of these might be slow to learn that, if the preservation of concrete remains, and the ability to offer the tribute of devotion at a shrine be desired, cremation equally, if not better than burial, secures those ends. On the other hand, I know how many there are, both in this country and abroad, who only require the assurance that cremation is practically attainable to declare their strong preference for it, and to substitute it for what they conceive to be the present defective and repulsive procedure. A few such might, by combination for the purpose, easily examine the subject still further by experiment, and would ultimately secure the power, if they desired, to put it in practice for

themselves. And the consideration of the subject which such examples would afford, could not fail to hasten the adoption of what I am fairly entitled to call, the Natural, in place of the present Artificial Treatment of the body after death.—*Contemporary Review*.

---

## THE FUTURE OF ALCHEMY.

BY CHARLES FROEBEL.

THERE are few ideas more fatal to the exercise of that prophetic sight, by which we hope to penetrate the uncertainty of the what-is-to be, and distinguish the dark forms of the future, than the two notions: that history repeats itself, and that any form of feeling, of thought, or of motive, when once extinguished, must forever remain so. Though widely accepted, these two notions evidently contradict each other, and this contradiction is in itself a sufficient proof of their necessary mutual limitation. Yet, when limited by comparison, the two ideas find a joint expression in the moral law, that while infallibility is not of the human mind, and while all our views and forms of mental activity enshrine but a spirit of verity in a clay of illusion, it is only this body of error which the scythe of Time consigns to the grave, while the immortal soul of truth lives on.

Some centuries ago, the system of ideas known to history as Alchemy held universal sway over the minds of men; now there are none, among the cultivated at least, who dare to defend its assertions. And yet we may inquire what there was in these ideas that so commended them to men's minds, that at a time their authority was almost beyond dispute. What, we may ask, was the soul of truth, the immortal part, in the day-dreams of wealth, of power and of beauty, of magic and mystery, which formed the erroneous body of alchemistic belief?

The opinion most widely and popularly entertained at the present time ascribes to the alchemical pursuits of the middle ages a mixed character: it holds the aim of alchemy to have mainly consisted in the transmutation of the baser metals into gold; it regards the alchemist as a man who, intensely selfish in his purpose, bore either the character of the unreasoning, visionary dreamer, of the magician moving among the phantoms of superstition, or of the charlatan and cheat living upon the credulity of the avaricious, and who sought, in the application of an exceedingly limited stock of scientific knowledge, the means for the accomplishment of his ends.

But, to the thoughtful student of history—not the history of political events, it is true, nor the history of science, or of any other isolated and abstract phase of human activity, but of history in its highest conception; a history which seeks and finds, in each of the



phases of life, the determining influences of all the others—the face of alchemy wears a different aspect.

At the time when alchemistic views were most widely disseminated and accepted, and alchemistic pursuits most widely, frequently followed, alchemy had one chief central object—the production of the philosopher's stone, a substance of marvelous properties and power. By those who claimed to possess it, it was generally described as a red, glass-like powder. When it was projected, that is to say, inclosed in wax, and thrown upon any base metal in a state of fusion, it instantly ennobled it, converting it into gold. When it was taken as a medicine, it was not only productive of perfect health, but even effaced the effects of time, bestowing all but eternal youth. And, even more than this, it was held to purge its fortunate possessor of all sin and moral evil. The transcendent value of such a substance is readily understood, and it is not to be wondered at that philosophical voyages, undertaken in its search, formed at a time the favorite enterprise of the alchemistic adventurer. But these attempts at its preparation were fraught with innumerable difficulties, beset by untold obstacles. The philosopher's stone was not held to be obtainable from any and every substance, but only from the peculiar material known in those days as primeval matter. Where this material was to be found no one could clearly state; the alchemists refer to its origin in dark, mysterious, unintelligible language. Hence it was sought far and near; in all countries; in the mineral, the vegetal, and the animal world; in the earth, the air, and the waters. According to the statement of the alchemist, he converted this peculiar material into another—the philosophical mercury or pure spirit of metallicity. Joining this with philosophical gold—that is to say, the pure spirit of goldenness—he placed the strange mixture in a certain vessel, the philosopher's egg, heated it in the philosopher's furnace, and hatched the philosopher's stone. It is scarcely necessary to say that the substances named do not exist. The process of making the stone was expressed in dark, enigmatical language. The open communication of the secret was held to be sinful, and liable to be punished by the instantaneous annihilation of the offender. These were the means and purposes of alchemy in the most exalted stage of its development, which it had attained toward the middle of the fourteenth century. Before the thirteenth it was immature; after the fifteenth it fell into decay.

The current of alchemistic opinions and pursuits issued from the dark ground of the Egyptian temple. Gathering the influences of Oriental Christianity, and taking in those of the Mohammedan torrent, it flowed away to the bleak shores of culture in the Christianized North. Egypt endowed it with its veil of mystery and its sacred character. The philosophy of antiquity bestowed upon it its fatal birth-gift of theoretical error. In Egypt it had been combined with astronomy and astrology, and, when that country passed under the sway of the Moham-

medan conquerors, the alliance of these pursuits was further strengthened by the fatalism of the Arabian. Seeking for the philosopher's stone an ideal of material perfection, and uniting with this pursuit that of the physician, the alchemist was led to regard the imperfection of the baser metals as a disease, the supposed operation of the stone as a process of healing, and to ascribe to it the properties of a universal medicine. Transferred to northern soil, at the time when mediæval Christianity attained its most exalted development, alchemy became thoroughly infused with the religious spirit of the period and its tendency to regard things material as analogous to and symbolical of things spiritual. Passing into the shadow of the cloud and mist-born Northern deities, still hovering over the thrones from which they had been hurled by the Christian angelic host, alchemistic pursuits became involved with the belief in magic and witchcraft. And then the great spiritual revolution which struck at the power of Catholic Rome also weakening the authority of ancient alchemistic views, they became the adroitly-wielded weapons of swindler and charlatan, who were only disarmed when the calm criticism of chemical science disproved the assertions of fraud.

But, at the time when the belief in the reality of the philosopher's stone was general among the cultivated as well as the ignorant, alchemistic hypocrisy was not common. More frequently, then, the alchemist was either an excited enthusiast, led astray by the mirage of his hope, or the cautious commentator who lent the weight of his name merely to give currency to the reports of older authorities. Nor was covetousness always the leading motive of the alchemists. Some of the most illustrious of them apparently persevered in their search for the philosopher's stone without a single sordid thought; many sought to make their pursuit tributary to the healing art; many also regarded their labor as one of the duties of a life of religious devotion.

Alchemy is often represented as immature chemical science, but even this view is only partially correct. The essence of science consists in experimental investigation; but, though many of the alchemists made discoveries, and some of them were investigators, the greater number, and some of the most illustrious, were rather men who, born to the habit of religious enthusiasm, and led by a beacon-light from the ideal world across the threshold of reality, only now and then stumbled over a new fact. Closer by far is the relationship subsisting between the alchemy of the past and the chemical technics of today. Most generally, the aim of the alchemist was not to discover, but to create. Indeed, alchemy had a constant purpose—the production of a perfect agent of chemical change—the philosopher's stone. It was a purpose which was never accomplished, an aim which could not possibly be attained—at least, not in the way and time dreamt of by the alchemistic enthusiast, nor by the means at his command.

Most of the arts reward the laborer, who engages in their pursuit,

with the attainment of his aim. But, though most of the arts do so, all do not. For, among that vast group of human activities to which the name of "arts" is applied, there are certain forms, the very essence of which consists in the seemingly unattainable character of their ends. And these activities, constantly striving for the absolute—for ideals of the many forms of beauty and of strength—are those known as the "Fine Arts."

But all the forms of the ideal world are a part of the religious system of a time, and for this reason all the fine arts have ever been in such close relation with religious belief. And, consequently, when we consider the essential and persistent characteristics of alchemy, such as its intimate connection with religion, and its endeavors to realize chemical ideals, we are compelled to regard alchemy as a primitive fine art, which fell into decay on account of the extreme inadequacy of its means, and the despondency of the artist. The true artist-hero, when he perceives that the absolute perfection he aims at is unattainable, save by the moral, intellectual, and technical education of successive generations, undismayed persists in creating, though not the ideal, yet at least beautiful forms, adumbrations of its image. The alchemist, when he saw that the prize was not to be attained in his day, ignominiously abandoned the field of action.

These facts point to a probability of the revival of alchemy in the future. But the conception of the perfectibility of matter is closely united to that of its transmutability. And when we inquire, "Has the chemical science of our time, by the unceasing toil of the last two centuries, not already developed the means which might enable us to successfully resume the great work of alchemistic art?" we receive not a favorable answer. Chemistry has taught us to resolve compounds into elements and to unite elements to compounds, but it knows naught of transmutation; all its inductions seem to disprove the existence of any reality corresponding to the idea. Year by year the belief that definite, specific forms of matter, such as water or iron, though resolvable or combinable, are yet in themselves absolutely fixed and invariable, has become more firmly rooted. And, if we would therefore hope to see the transmutation of imperfect forms of matter into others more perfect realized, it is not on the inductions and theories of chemistry that our hopes may be founded. It is among chemical conditions, and with the aid of chemical knowledge, that the future alchemist must resume his pursuit; but, before he may do so with any promise of success, these conditions and that knowledge must undergo a change, and chemical science, unleavened as yet by the thought which shall work it, must receive it from without.

The source whence this thought may be derived is the current of organic science, now distributing far and wide the fertilizing influence of the theory of evolution, a view of creation which, though not new,

was not victorious until, within the last decades, Charles Darwin led upon the hard-fought logic-field an array of facts glittering in their strength. Before a victory had been conquered by the Darwinistic school, the specific forms of vegetal and animal life were held to be immutable. While it was known that among the individuals of any one species certain differences, justifying their being classed as distinct varieties, might arise in the course of successive generations, all such variations were held to be bounded by certain more or less narrow limits of possibility. The facts adduced by the new school of biologists have led to different conclusions, culminating in the assertion that all organic forms are changeable without limit—transmutable without end—capable of a physical, intellectual, and moral elevation, which knows no boundaries.

According to the theory of evolution, the modifications of structure and capability which organic forms are liable to undergo, in the course of generations, may be traced back to three principal causes. The first of these is the influence of physical forces, as, when the strength of the muscles is enhanced by exercise, the mind invigorated by thought, or, inversely, their function impaired by long-continued disuse. The second cause consists in the transmission of these results of individual life to a line of descendants, the effects being compounded, as they pass, with others of the same order. The third cause is to be found in the competition of the forms so produced under circumstances not equally well adapted to their capacities nor sufficient for their co-existence, leading necessarily to the preservation of those races which are best, and the extinction of those which are least, fitted to endure adversity. To this last cause, constantly active in the organic world, the term "natural selection" has been applied, to distinguish it from the artificial selection of the stock-breeder and gardener. The changes wrought in organic forms by the influence of inorganic forces are generally spoken of as variation. But this variation is in reality merely an extension of the principle of competition. Organized beings are brought face to face with the forces of Nature, with the earthquake, the flood, the lightning, and the storm. Often they meet in mortal conflict. The living form sinks to the earth before the power of the thunder-bolt, or the thunder-bolt is conquered by the invention of genius. Death is but a victorious alliance of inorganic forces triumphing over the organic form laid low on the battle-field; life is but the victory of the organic forces over the inorganic hosts. But, do we not also behold a competition taking place between, a struggle for existence and a natural selection occurring among, inorganic forms? Cast water upon fire; either the water disappears as vapor or the fire is extinguished. A mixture of salt and gravel is brought in contact with water; the salt is dissolved, the gravel remains unaltered. Heat a mixture of salt and sal-ammoniac; the salt persists, while the sal-ammoniac is vaporized.

And here we may ask: "Is the distinction between that which is living and that which is not—between the organic and the inorganic worlds around us—properly drawn?" If the changes undergone by the forms of both are due to the same causes, wherein lies their difference? Both forms are capable of assimilating material from without; the organic by nourishment, the inorganic directly, as when a crystal grows by the assimilation of material from a solution in which it is placed. Both also are capable of producing offspring—at least by division if not by sexual genesis. Are we then justified in assuming the gap of distinction between these two orders of existence to be as wide and deep as it is generally considered? Life is the gradual modification of material forms by the action of physical forces; the continuity in time of the changes thus wrought; the competition of the forms thus evolved. It is the projection of the past into the future. It is the persistence of history.

And we may well question whether it were not better to extend our idea of life. Even if that wide gap which we imagine to open between the organic and the inorganic does exist, we may still ask: "Is the organic form the only living one, and the inorganic form so absolutely dead; or do they not rather both constitute forms of life radically and polarly opposed—vast alternate generations of existence, majestic in their mystery?" The power which fashioned this earth wrote not only upon the bark of the tree and the brow of man, but also upon the cold and passionless rock and the wide expanse of the deep, blue sea, their history. That which is seemingly so inanimate, as well as that which throbs with a warm consciousness of being, obeys the commanding influences of the past, and transmits them to the future. The biologist and the geologist have read the story; where they have not—the letters await but the riper wisdom of the yet unborn sage.

But the chemist has not yet acquired a knowledge of his historic alphabet. To him specific forms of matter are still immutable, unvarying, constant. He knows naught of differences wrought by the influences of the past, or of their transmission to the future. He is not aware of a competition or struggle for existence taking place between individual and specific forms of matter. The idea that substances, as we find them, are the result of a process of natural selection has been expressed, but it is as yet unsupported by experiment or interpretation of facts observed.

But, where a natural selection takes place, artificial selection is also possible; and, when chemistry shall develop before us the spectrum of the law of inorganic creation, the artistic spirit will seize upon the individual colors of truth, and once more endeavor to paint the image of the chemical ideal. The recognition of the law of evolution compels the acceptance of the inexorable conclusion that the competition of races must, in the course of infinite ages, inevitably lead to the ab-

solite perfection of the enduring forms. Natural selection this hope has been called, because the hand of Nature bestows the warrant of nobility. But man is himself only a part of that great, that bountiful, that all-generous Nature, and it is wrong to speak of the selections he has made among the flowers which embower his dwelling, and the half-mute companions of his home, as artificial. In making these he is but executing the commands of Nature, as the most skilled workman in her earthly palace of labor, and the approximations to perfection which she initiates by the intellectual and moral lever of his mind distance all others known to us.

The chemistry of to-day is, in part a science searching for forms of truth; in part an art pursuing the objects of the useful. The scientific chemist seeks and discovers realities of fact; the technical chemist produces realities of matter; neither of them endeavors to give existence to material ideals. But though man may thus unconsciously serve the inscrutable power through which all is that is, and all is what it is, yet of nobler mood is he who, feeling his heart swell in sympathy with her purpose—the creation of ultimate universal perfection—persists in constant faith to work her ends. Of such noble mood, and of such conscious purpose, must be the future alchemist. His work—the reformation of the crude earth, and air, and waters, that surround us, in the image of his chemical ideals, the production of untold varieties of the philosopher's stone—is not to be accomplished in a lifetime, or a century, but demands the continued labor of infinite generations. We shall never behold it, but—

“On the day when, drawn on paths of duty,  
The last worlds—eternity-begun—  
Rest, embraced in ever-glorious beauty,  
On the heart of the All-Central Sun”—

shall most surely be witnessed its completion!

---

## PROFESSOR LOUIS AGASSIZ.

BY RICHARD BLISS, JR.,  
OF THE CAMBRIDGE MUSEUM OF COMPARATIVE ZOOLOGY.

**L**OUIS JEAN RODOLPHE AGASSIZ, whose death occurred the 14th of last December, was born May 28, 1807, in Mottier, Switzerland. From his earliest childhood he evinced a remarkable fondness for the study of natural science, and before he had left school began to collect and study into the habits of fishes. Having finished his course at the Gymnasium of Bienne, he chose for his profession that of medicine, and commenced to study at the Academy of Zurich. Thence he went to Heidelberg, where he made a special study of



anatomy. He next entered the University of Munich, where, in company with Martius, Oken, Döllinger, and Schelling, he devoted himself eagerly to the pursuit of natural history. At that time Martius was publishing his great work on the "Natural History of Brazil," and, upon the death of Spix, who was editing the zoological portion, Martius intrusted to Agassiz the description of the fishes. In this work, which was admirably well done, Agassiz characterized nine genera, embracing forty-two species new to science.

For some time Agassiz had contemplated a monograph on the "Fresh-water Fishes of Central Europe," but pecuniary embarrassment rendered this impossible, till a bookseller by the name of Cotta, to whom Agassiz showed the material he had collected, furnished him the means necessary for its completion. Meanwhile he studied and obtained the degree of Doctor of Medicine at Munich, and of Doctor of Philosophy at Erlangen. After his examination, Agassiz went to Vienna, and applied himself closely to the study of actual and fossil ichthyology. From Vienna he went to Paris, where he made the acquaintance of Cuvier and Humboldt, both of whom warmly welcomed this expert young naturalist. Here he lived on the most intimate terms with Cuvier till the death of that naturalist, in 1832, when he returned to Switzerland and established himself at Neuchâtel, where he was appointed Professor of Natural History, a position he held till his departure for America.

Through the influence of Humboldt, between whom and Agassiz there existed the warmest friendship, he was enabled to begin the publication of his "Poissons Fossiles," a work evincing such careful and profound research, and such a wonderful power of generalization, as to obtain for him a place among the very first naturalists of the day. This work, which appeared in parts, between the years 1833 and 1845, comprises five volumes, of about 1,700 quarto pages, with an atlas of 400 folio plates, and contains descriptions of nearly a thousand species of fossil fishes. Aside from the great number of species, genera, and families established, Agassiz adopted an entirely new system of classification. In the classification proposed by Cuvier, fishes were divided into two orders, according to the nature of the skeleton, viz., cartilaginous and osseous. Agassiz—looking upon the external covering of the animal as a reflex of the connection existing between the being and its surroundings, bearing the imprint of all the peculiarities of its existence, and consequently of its organization—deemed that the true principle of the classification of fishes was to be found in the scales. In view of this he proposed a division of the families of fishes into four orders, viz., *Placoids*, in which the scales are represented by plates of enamel, as in the sharks; *Ganoids*, in which the scales consist of angular bony plates covered with a thick layer of enamel, as in the gar-pikes; *Otenoids*, or fishes with true scales, in which the posterior edges of the laminæ are toothed; and *Cycloids*, in which the scales are com-

posed of simple laminae with smooth posterior edges. This last order Agassiz subdivided into Acanthopterygian and Malacopterygian Cycloids, or fishes having two dorsal fins, one spiny and the other soft, and those having one soft dorsal fin. Agassiz found that the study of fossil fishes exhibits a remarkable parallelism between the development of the individual and that of the class in geologic time. During part of the embryonic life of fishes, and even in some adult forms, the dorsal cord exists as a simple gelatinous cylinder, surrounded by a fibrous sheath, in which, after a time, there is found a cartilaginous and then an osseous deposit, which goes to form the vertebræ, the ossification taking place first in the apophyses. This embryonic character Agassiz found to be peculiar to the fossil fishes of the earlier geologic ages. There is no trace of a vertebra, but the apophyses, usually ossified, rest directly on the spinal cord.

Regarding the permanence of type, the author found the species of one formation specifically distinct from those of another, and, while it is impossible to say that the species pass from one into another, as they appear and disappear suddenly without direct connection with their predecessors, yet, as a whole, they present a continual progress of development, from the lowest to the highest, and demonstrate most palpably the existence of an ever-present directive intelligence.

Up to the end of the Jura epoch there exists among fishes a uniformity of type as well as a uniformity in the different parts of the animals themselves. The Placoids and Ganoids were the only fishes then inhabiting the seas; but, as we approach the Jurassic period which became preëminently the age of reptiles, we find a remarkable abundance of Sauroids, which, in their osteological character, the organization of their soft parts, and their dermal integuments, approach so nearly the reptile Saurians. At the end of the Jura period we find the Ganoids and Placoids giving way to the Ctenoids and Cycloids, which at present constitute the majority of our fishes. In the chalk-group, two-thirds of the species belong to extinct genera; in the inferior tertiary, one-third. In the Norfolk clay and Molasse formations the genera, for the most part, approach those of the tropical seas of the present day; and in the Geodian clay of Greenland there is found a species identical with one now living. In addition to the description of the species, which occupies the bulk of the work, a chapter is devoted to a critical review of the fishes of Monte Bolca, and another to those of collections in England and Scotland.

Agassiz next turned his attention to the study of Mollusca and Echinoderms, and in 1836 published a prodromus of the Echinoderms, and in 1837 a treatise on the fossil Echinoderms of Switzerland. In 1839 he began a more elaborate work, entitled "Monographies d'Échinoderms vivant et fossile," a most important contribution to modern zoology. This work comprises five parts: the first and second, on the *Salenies* and *Scutellæ*, by Agassiz; the third and fourth, on the *Galerites*

and *Dysaster*, by Desor; and the fifth, on the *Anatomy of Echinus*, by Valentin. Among the Scutellæ Agassiz found well-marked differences between the living and fossil species, and that all the species of the genera *Mellita*, *Rotula*, and *Encope*, belong to the existing epoch. He found, moreover, that the species increase in size as they approach the present period. While he was publishing his work on the Echinoderms, this indefatigable naturalist also described and figured a large collection of fossil shells from the Oölite and Cretaceous formations, in a work entitled "Études critique sur les Mollusques de Jura et de la Craie," besides an annotated German translation of Buckland's "Geology," and French and German translations of Sowerby's "Mineral Conchology."

Notwithstanding the immense amount of work on his hands, Agassiz found time to prosecute his investigation upon the fresh-water fishes of Europe. The first part of this work, issued in 1839, is devoted to the genera *Salmo* and *Thymallus*. It appears as a folio of twenty-seven excellent plates, with descriptions illustrating six species of *Salmo* and one of *Thymallus*, one plate of each species being colored according to life, the others representing differences of age, sex, and locality. The second part, which did not appear till 1842, consists of a folio of plates and a volume of text on the "Embryology of the Salmon," by Carl Vogt, whom Agassiz had associated with him in his work. M. Vogt has given the most detailed descriptions and figures of the different organs, and the changes they undergo from the formation of the cellules, out of which the organs are developed, to the adult state. In regard to cell-formation, M. Vogt differs from Schwann in affirming that the germinative vesicle is formed prior to the nuclei and nucleoli. The volume closes with a history of the daily development of the embryo, from the exclusion of the egg to the birth of the young. This excellent work was never completed; Agassiz's departure for the United States shortly after, and his increasing responsibilities, prevented the perfection of his original plan.

In 1842 Agassiz began the publication of his "Nomenclator Zoologicus," an alphabetical list of every genus, with the name of the author, the work in which it originally appeared, the derivation of the name, and the family to which the genus belongs; the list embracing upward of seventeen thousand names. In the introduction the author examines the rules proposed by the British Association and those of the British Committee. He agrees with the rules proposing that the name given by a founder of a group, or the first describer of a species, should be retained, and that priority is to be conceded only to a name published in some universally accessible work. On the other hand, he objects to the restriction of priority to Linnæus and to the rule that would change a name previously in use in connection with some other genus in zoology or botany, as this would result in the sacrifice of half the names of recent times. He does not think it wise

to discard *barbarous* names, and, when a species becomes the type of a new genus, he would retain the former specific name as the generic appellation. He objects to the use of small initial letters for substantives borrowed from persons or places, to the uniform restriction of family and sub-family terminations to *idæ* and *inæ*, and strongly condemns the proposition that the name of the original propounder of a species should be retained when the species is transferred to a different genus. He likewise condemns those who would change the authority for a genus when the name is changed through faulty orthography, and censures the use of vernacular names in scientific works to the exclusion of the systematic ones.

The "Fossil Fishes" was now approaching completion, but, in consequence of additional material, Agassiz determined to publish a supplement; and accordingly there appeared, in 1844, the "Fossil Fishes of the Old Red Sandstone." It was accompanied by an atlas of thirty-nine folio plates illustrative of the seventy-six species described. The author, after discussing the relative rank of the members of the various classes of the animal kingdom, and showing how closely the time of their appearance on the earth corresponds to their relative standing in their respective classes, announces the conclusions to which a study of the fishes of the Devonian system had led him. These fishes actually represent the embryonic age of the Reign of Fishes, undergoing "phases of development analogous to those of the embryo, and similar to the gradations which the present creation shows us in the ascending series it presents when viewed as a whole." The members of the five families whose species he describes, are characterized by the absence of distinct vertebræ, the apophyses resting on the spinal cord, and by the absence of ossification in the internal case of the cranium. In these characters, as well as in the peculiar development of the vertical fins, the heterocercal tail, the flattened form of the head, and inferior or sub-inferior mouth, we see peculiarities of structure common to the embryo and the lower forms of existing as well as paleozoic fishes. This affords us a key to the relative rank of these fishes, for we find the *Cephalaspides*, which recede most from the existing forms, confined to the Devonian. The *Sauroids*, which are represented only by a particular group—the Dipterians—are likewise confined to the Devonian. The *Acanthodians* become extinct at the end of the Chalk, while the *Cestraciontes* persist to the present epoch. The same year Agassiz also read before the British Association a "Report on the Fossil Fishes of the London Clay."

Of all Agassiz's investigations, perhaps none made his name more popularly known than his studies on glaciers—studies which were pursued through a long course of years, and conducted with the same painstaking care that had heretofore characterized all his labors.

About the year 1834, M. Charpentier advanced the theory that the erratic blocks, and certain dikes of peculiar shape found in the

Alpine regions, were the result of the action of former glaciers descending from the Alps and reaching even the upper portions of the Jura. This theory Agassiz deemed improbable, till, having visited Charpentier and investigated the phenomena, he not only became convinced of the correctness of Charpentier's views, but deduced from these and other phenomena a theory which, at the time (1837), was startlingly novel. It was that, previous to the elevation of the Alps, the globe experienced a very great reduction of temperature, and that the appearance of those mountains found the surface of the globe, from the north-pole to the Mediterranean Sea, covered with an immense sheet of ice. An elevation of temperature, consequent upon the upheaval of the Alps, caused this ice slowly to disappear, remaining longest in the valleys, where it gradually retreated to its present limits, leaving behind it, as a record, the peculiar phenomena which have attracted the attention of so many observers.

Of course a theory so novel at once raised a storm of opposition, and it became necessary for Agassiz, if he would prove the correctness of his views, to make the most careful and thorough investigations on living glaciers. For this purpose Agassiz, in company with Desor and several others, made visits in 1838 and 1839 to the glaciers of Mont Blanc and the Bernese Oberland, and in 1840 established himself for the summer on the glacier of the Aar. That year he published his "Études sur les Glaciers," giving the results of his investigations up to that time. He also visited England, Scotland, and Ireland, and studied the evidences of ice-action in those countries.

But his labors were not finished. Doubting the sufficiency of the theory of De Saussure—that the cause of the motion of the glacier depends upon gravity—and inclined to accept the dilatation theory of Schenchzer, it became necessary for him to examine with care the structure, form, distribution, and rate of motion of the glacier. Thus it was that, in 1841, he began a second series of observations for the purpose of determining these points. He chose, for the theatre of his investigations, the glacier of the Aar, which, by its extent and accessibility, promised the most favorable results. In 1845 he had completed his work, and in 1847 appeared his "Système Glaciaire," which embodied the final results of his researches upon the structure of glaciers, and their effects upon the soil. The results at which he arrived may be summarized as follows: The glacier is a mass of ice reclining on the side of a mountain-ridge, or inclosed in a mountain-valley; it is always descending, and, while wasting away from heat at its lower extremity, is continually augmented at its source. The primary material of glacier-ice is the snow which falls in the high regions of the mountain. The yearly addition of snow in the higher cold regions gradually forces the snow down the valley; here, subject to alternate thawing and freezing, it undergoes a second crystallization into what is called *névé snow*, and still farther down, under increased pressure, be-

comes transformed into a granular, opaque, bulbous ice, called *névé ice*, which at last changes into the compact blue ice of the glacier proper.

During the summer, when the snow-fall is at its minimum, the surface of the snow in the high regions becomes covered with dirt and sand, which the next winter covers with another snow-sheet. In summer these layers of snow, from a partial melting and subsequent freezing, become changed to ice on their surfaces, so that we have three kinds of deposits—beds of snow, sheets of dust, and layers of ice. As the whole is pushed down into the valley, these layers tend to assume a vertical position from the bottom of the mass, moving faster than the top; and, the snow in summer melting from the surface as far as the snow-line, the edges of the layers are found passing transversely across the glacier. The middle of the glacier being deeper, moves faster than the sides, and, the lower layers advancing more rapidly than the upper ones, the strata become curved forward, the lower layers being more sharply arched. The arch thus becomes the measure of the rate of movement in the different parts of the glacier. From this it will be seen that Agassiz dissents from the theory of Tyndall, which represents the stratified lines as due to *ice-cascades*, or breakages of the glacier in passing over sharp angles.

All glaciers exhibit numerous blue bands, which are parallel to the planes of stratification, and are formed by thawing and freezing, and by the vertical pressure of snow in the *névé*. Moreover, there are found certain veined structures of the ice which appear to be bands of infiltration, and intersect the planes of stratification at every possible angle. As they are most numerous at the sides of the glacier, it is probable that Tyndall's theory of internal liquefaction of ice by pressure may account for them.

In the progress of the glacier, its rate of movement is not uniform, the differences between the centre and the sides being about as ten to one. Neither is the motion uniform along the axis; the advance being greatest about half-way down the region of the *névé*, and diminishing in rapidity both above and below. Agassiz found that it was from 20 to 50 feet per year in the higher portions, about 250 feet in the *névé*, and diminishing again lower down.

The causes of the movement of the glacier are several. The weight of the glacier alone is not sufficient to propel it, as in this case the greatest movement would be in the winter, which is not the case. The principal agent is the infiltration of water, which is greatest when the winter snows are melting. The granular snow of the *névé* incloses numerous particles of air, which, when the snow is compressed into ice, form a net-work of capillary fissures that serve as canals of infiltration, the water in which, freezing, aids in propelling the glacier. Added to this may be such other causes as the weight of the mass, the pressure of accumulated snow above, the weight of infiltrated water, and the softening of the ice by water, and a consequent sliding along the surface.



The sides as well as the bottom of the glacier are studded with bowlders, pebbles, and sand, forming a gigantic rasp. As the glacier moves forward, this rasp grinds, furrows, and polishes the rocks over which it moves, the furrows trending in the direction in which the glacier moves. These furrows and polished surfaces, which are often observed on rocks remote from any living glaciers, are the record of the former existence of glaciers in such places. When the ground is uneven, the eminences being small, and the hollows too deep and wide to be bridged over by the glacier, the ice-rasp rounds and polishes these knolls, forming those rounded elevations which have received the name of *roches moutonnées*. In consequence of the rocky walls above the sides of the glacier becoming warmed by the sun, the ice is melted near them, and hence the glacier becomes convex. Into these troughs the *débris* from the walls fall and form long lines of bowlders, pebbles, and sand, which are called *lateral moraines*. When two glaciers flow together, the two lateral moraines on the adjoining sides of each unite and form what is called a *medial moraine*. A third form, the *terminal moraine*, is the accumulation of sand and rocks which the glacier pushes before in its progress down the valley. In consequence of the increased rate of progression of the centre of the glacier, these terminal moraines assume a semicircular form, which, when the glacier retreats, consequent upon an excess of liquefaction over the snow-supply, leaves a crescentic wall across the valley, usually cut in two by the river flowing from the glacier. The erratic blocks which are found over most of the globe, accompanying scratched and polished rock-surfaces, are simply the bowlders of the surface of the glacier left on or near the spot where they stood when the glacier disappears.

In the fall of 1846 Agassiz sailed for the United States, on a mission from the Prussian Government. The warm reception which greeted him here, and especially the rare field for scientific research which this country afforded, determined him, the next year, to make America permanently his home. The professorship of Natural History in the Lawrence Scientific School at Harvard College being offered him that same year, he accepted it, and held the position till his death, with the exception of two years when he occupied the chair of Natural History in the University of South Carolina, at Charleston. In 1848, in connection with H. E. Strickland, he began the publication of a "Bibliographia Zoologiæ et Geologiæ." This work, which comprises a list of all the periodicals devoted to zoology and geology, and an alphabetical list of authors and their works in the same departments, was completed in four volumes, the fourth being published in 1854.

Agassiz's studies on the glaciers of Switzerland led him to expect to find in the United States many traces of former ice-action. Nor was he disappointed. He explored the country from the Atlantic to the Rocky Mountains, from the great lakes to the Gulf of Mexico, and everywhere, north of the thirty-fifth parallel of latitude, found evi-

dences of glacial action, in erratic blocks, polished and striated rock-surfaces, and terminal moraines. Naturally this served to confirm him in his belief in the universality of the ice-period; and, upon his departure for Brazil, in 1865, he announced his confident expectation of finding records of the former existence of glaciers in that country; for, according to his belief, not only most of the Northern, but also most of the Southern Hemisphere was, during the glacial epoch, encased in ice. The evidences of glacial action in the United States are fully discussed by Agassiz in his "Lake Superior," a work on the physical character, vegetation, and animals, of Lake Superior, compared with those of other and similar regions.

Agassiz was a firm believer in the diversity of origin of the human race, and his views on this point are ably presented in the *Christian Examiner* for July, 1850, and in an introduction to Nott and Gliddon's "Types of Mankind." While denying the unity of origin of the races of mankind, he by no means denies their essential unity as one brotherhood. He regards all races of men as possessing in common the moral and intellectual attributes of humanity which raise them above the brutes. But intellectual relationship does not imply community of origin. The geographical distribution of animals shows that distinct zoological provinces are each characterized by peculiar fauna, and that therefore animals did not originate from a common centre nor from a single pair. The races of men, in their natural distribution, cover the same ground as the zoological provinces, and he believes there is every reason to suppose that these races originally appeared as nations in the regions they now occupy. That the differences at present observed between various races are primitive, and have not been the result of modification from one common ancestral type, he believed is evidenced by the monuments of Egypt, which show that, for 5,000 years, there has been no physical change in the negro and Caucasian.

In 1850 there appeared in the Transactions of the American Academy of Arts and Sciences an article on the naked-eyed Medusæ, being Part I. of Agassiz's "Contributions to the Natural History of the Acalephæ of North America." He includes all the naked-eyed Medusæ in one family, and shows that the number of tentacles and the position of the ovaries alone cannot be considered as family characters. The true characters consist in a gelatinous disk, with a re-entering margin, along which passes a submarginal tube connecting with the circulatory tubes proceeding from a central digestive cavity. Upon the margin are the tentacles and eye-specks. The reproductive organs are situated along the circulatory tubes. The generation is alternate, one form being polyp-like, the other medusoid. The nervous cord follows the circular submarginal tube, and consists of several rows of nucleated cells, alternating one with another. It passes into the bulbs at the base of the marginal tentacles, in which are situated the eye-specks. A branch of nerve-thread passes also along each of the

radiating circulatory tubes to the digestive cavity. The circulatory fluid is chyme, and not chyle, as it is in the Articulata and Mollusca. The author describes four species, and distinguishes a new genus—*Nemopsis*.

Ever since his arrival in America, Agassiz had been collecting material for a series of "Contributions to the Natural History of the United States." In 1857 appeared two volumes of these contributions; the first containing an "Essay on Classification" and the history of the North American Testudinata; the second on "the Embryology of the Turtle."

In the essay on Classification, Agassiz affirms that Nature is but the expression of the thought of the Creator, and that a true classification will be found to be but an unfolding of the plan of creation, as expressed in living realities; that these realities do not exist in consequence of the continued agency of physical causes, but appear successively by the immediate intervention of the Creator. We find in Nature a progressive series, from lower to higher forms; but it is not a uniform progress for the animal kingdom as a whole; neither is it a linear progress for the branches or classes, but a progress in which each type has usually been introduced by the creation of species belonging to one of its higher groups, for the earliest representatives of a class do not always seem to be the lowest. Yet, notwithstanding these downward steps, the progress has continually tended toward the production of higher and higher types, culminating at last in Man.

We find a parallelism between the geological succession of animals and the embryonic growth of their living representatives, as well as a parallelism between the geological succession of animals and their relative rank. The earlier types of animals were synthetic or prophetic, foreshadowing a future group. Types likewise culminated and disappeared in past ages—a feature parallel with the fact that in embryological development parts fulfill their end and then disappear.

Regarding Nature as the embodiment of a certain divine plan, Agassiz sought for a classification that should be the expression of this plan. Accordingly he based his classification on the following divisions, which he deemed covered all the categories of relationship, as far as their structure is concerned: *Branches*, or types characterized by their plan of structure; of these, he admitted four, Vertebrates, Articulates, Molluscs, and Radiates. *Classes*, which are characterized by the mode of execution of the plan. *Orders*, by the degree of complication of structure. *Families*, by the form as determined by structure. *Genera*, by the details of execution; and *Species*, by the relation of the individuals to one another, and to the world in which they live.

In Part II., Agassiz believes that the Testudinata constitute an order among the class of reptiles; that their essential character lies not so much in the shield as in the special development of different regions of the body, thus giving them the highest rank in the class.

The shield is partly a portion of the skeleton, and partly an ossification of the skin or of the walls of the body.

The second volume treats entirely of the embryology of the turtle, and is illustrated with thirty-four plates. The egg originates from between the cells of the stroma, and is in itself the animal in the first stages of development. The eggs are laid once a year, and grow a long time before they are fecundated. From the first copulation to the laying, four years elapse, during which time eight copulations take place. The segmentation of the yolk takes place during the passage of the egg through the oviduct. From the segmentation of the yolk to the period of hatching, the egg passes through thirty-one stages of development.

The third volume of the "Contributions" appeared in 1860, and was devoted to the class of Acalephæ, the author treating specially of the order *Ctenophoræ*. The *Ctenophoræ* Agassiz divided into three suborders: the *Eurystomæ*, embracing three families, the *Saccatæ*, with three families, and the *Lobatæ*, with five families. The fourth volume of the "Contributions," in 1862, concluded the Acalephæ, treating of the *Discophoræ*, *Hydroidæ*, and the *Homologies* of the Radiata.

Of the more recent labors of Agassiz in connection with the Museum of Comparative Zoology at Cambridge—of which he was the director, and to which, in later years, he devoted his whole attention—it is not necessary to speak. With his journey to Brazil in 1865, and his later expedition from Boston to San Francisco on the United States Coast Survey steamer Hassler in 1872, the public is already sufficiently familiar. His last days were devoted to the cause of education, in the establishment of a school of natural history at Penikese Island.

Of the man himself but a word is necessary. As a naturalist, Prof. Agassiz was unwearied in his devotion to his favorite pursuits. He worked early and late, often denying to himself the most necessary rest and recreation; and his remarkably strong constitution sustained him under a strain that would quickly have proved fatal to a man of less vigor. His mind was preëminently great; gifted with a wonderfully retentive memory, he combined with it a power of generalization and quick perception that places him next to Cuvier, whose disciple he was, and whom he seemed to imitate. In his methods of investigation he was perfectly honest, and, though many might differ from him in his conclusions, none could deny the absolute integrity of his convictions. In his intercourse with his fellow-men he was extremely affable and genial, and especially so toward the young. With inexperience he was most patient and painstaking, never wearying in his efforts to aid. Tolerant of ignorance where associated with modesty, he had but little patience with arrogance and ignorance combined. His students will all bear witness to the unvarying cheerfulness and ready sympathy in him they had learned to look up to as their master.

## EDITOR'S TABLE.

*INFLUENCE OF SCIENCE UPON PHILOSOPHY.*

IN his thoughtful little work on "Recent British Philosophy," Prof. Masson, of the University of Edinburgh, has the following suggestive passages upon the subject indicated in the present title :

"However earnestly we may contend for such a notion of Philosophy as shall keep up the tradition of it as something more than Science, yet the perpetual liability of Philosophy to modifications, at the hands of Science, is a fact obvious to all. Not a new scientific discovery can be made, not a new scientific conception can get abroad, but it exercises a disturbing influence on the previous system of thought, antiquating something, disintegrating something, compelling some readjustment of the parts to each other, some trepidation of the axis of the whole. Sometimes the action is almost revolutionary. What a derangement in men's ideas about every thing whatsoever, what a compulsion to new modes of thinking, and to new habits of speech, must have been caused by the propagation of the Copernican Astronomy! What a wrench to all one's habits of thought, to be taught that the little ball which carries us rotates on itself, and is one of a small company of celestial bodies that perform their periodical wanderings round the sun, in lieu of the older astronomical faith, according to which the earth was fixed in the centre, and the limitless azure with its fires was one vast spectacular sphere, composed of ten successive and independent spherical transparencies, made to wheel round the earth diurnally for her solitary pleasure! Man's thoughts, even about himself and his destinies, could not but be changed in some respects by this compulsion of his imagination to a totally new way of fancying physical immensity and our earth's share in its proceedings. . . .

"It is not every day, indeed nor every century, that there occurs such a vast compulsory shifting of the very axis of men's conceptions of the physical universe as that which our ancestors had so reluctantly to submit to only a century or two ago. But

every generation, every year brings with it a quantum of new scientific conceptions, new scientific truths. They creep in upon us on all sides. Is Philosophy to stand in the midst of them haughtily and superciliously, taking no notice? She cannot do so and live. Whether she knows it or not, these are her appointed food. She must eat them up or perish. They do not constitute her vitality, any more than the food that men eat constitutes the life that is in them; but, just as men, in order merely to continue alive, must refresh themselves continually with food, so Philosophy, that she may not fall down emaciated and dead by the wayside, must not only not hold aloof from Science, but must regard what Science brings as her daily and delicious nutriment. Whatever definition of Philosophy we adopt—whether we call it simply and beautifully, with Plato in one passage, 'a meditation of death,' or adopt some of the more labored definitions that have been given expressly to indicate its relations to Science—it is equally certain that a philosophy that should be out of accord with any ascertained scientific truth or tendency to truth, or that should not in some efficient manner harmonize for the reason all the conceptions and informations of contemporary science, would be of no use for educated intelligences, and would exist as a refuge for others only by sufferance. Shall Philosophy pretend to regulate the human spirit, and not know what is passing within it—to supervise and direct man's thinkings, and not know what they are?

"In no age so conspicuously as in our own has there been a crowding in of new scientific conceptions of all kinds to exercise a perturbing influence on Speculative Philosophy. They have come in almost too fast for Philosophy's powers of reception. She has visibly reeled amid their shocks, and has not yet recovered her equilibrium. Within those years alone which we are engaged in surveying there have been developments of native British science, not to speak of influxes of scientific ideas, hints, and probabilities from without, in the midst of which British Philosophy has looked about her scared and bewildered, and has felt that some of her oldest statements about herself, and some of the most important terms in her vocabulary, require reëxplication."

The truths here enunciated cannot be too carefully pondered. In its modern progress Science has been constantly warned off from the field of Philosophy, as having no concern whatever with its issues or interests. But Science has no more choice or responsibility in regard to the results of its work than it has with regard to the phenomena which it investigates. If it is to be suffered to exist at all, it must proceed with its labor of investigating facts and establishing principles; to what conclusions these will lead depends upon nobody's preference, but upon the constitution of the universe itself. If the scheme of being around us is a harmonized and unified order, where all the parts are in reciprocal sympathy, then he who strikes an impulse is not to be called to account for the sweep and compass of the undulations which follow. Science may be occupied in her legitimate duty with simple laboratory experiments, and establish results that will thrill through all spheres of thought, and reach to the very core of philosophy.

Such a step was taken in the last century in establishing the indestructibility of matter. The problem that had baffled philosophy, for thousands of years, was settled by the experimenters. The truth which was inaccessible to speculation was arrived at by the physicists and chemists. It had been believed, for centuries, that in the changes of form—the appearances and disappearances of Nature—existence itself was implicated, and matter, the substratum of being, was continually created and destroyed. The poetic divination—

“The eternal Pan,  
Bideth never in one shape,  
But forever doth escape  
Into new forms”—

only became a demonstrated truth when the mechanics had perfected the chemical balance and made it possible to pursue the course of material

transformations. It was then found that the old belief in the destructibility of matter was without foundation, and that the persistence of material elements through all changes of form was demonstrated by every particle of evidence that bore upon the case. Philosophy, which aims at the deepest explanation of the order of things around us, if it has any aim worth pursuing, thus derived a new datum from the workshop; but how foolish to assume that, in elaborating it, the chemists were inspired with any purpose to trench upon the domain of Philosophy!

But this research, which ended in the establishment of the law that matter is indestructible, was but an apprenticeship for deeper and more delicate investigations of the same kind. The use of the balance led to the discovery of quantitative chemistry, the highest phase of the science, and strengthened the mental habit of regarding phenomena in their quantitative relations. Matter is not only associated with forces, but it is manifested and known through its essential and inseparable activities. It is not only determined by its forces, but it is measured by them. The very instrument by which matter was proved to be indestructible, was but a device for showing the constant relation of material bodies to the force of gravity. Cohesion, affinity, heat, light, and magnetism, are but dynamic affections of matter, which are involved in all its changes, and it was simply inevitable that when one element of things was proved to be essentially indestructible, through every mutation of form, the same inquiry should be pressed in regard to this character of the other forces. Naturally, and quite necessarily, the disciplined scientific thinkers of different countries, with no knowledge of each other's purposes, and proceeding from different points of view, were led to engage with the experimental problem of the quantitative interactions of



the molecular forces. The consequence of this was another step forward, of the greatest possible importance. It was shown that the physical forces are as obedient to quantitative laws as matter itself had been proved to be, and that, while they are mutually convertible into each other, force, like matter, is indestructible in its nature. The various forms of energy by which effects are produced in the surrounding world, although changing incessantly, were discovered to be never created and never annihilated. With the evidence that every form of force is derived from some preëxisting form of it, the hope of a mechanism generating its own power perpetually, passed away among impossibilities, and the science of forces became limited to problems of transformation. It was much to have exploded the fallacy of the perpetual motion, upon which the ingenuity and wealth of generations had been wasted, but it was far more to have seized upon a principle of Nature which Dr. Faraday could pronounce to be the highest law in physical science which our faculties permit us to perceive. And are the discoverers of this principle to be held accountable for the reach and play of its applications? No doubt a law of Nature's activities, thus supreme and far-extending, cannot be limited to the field of physical phenomena. The probabilities are strong that, wherever effects are produced in degrees of more or less, they are strictly conformable to quantitative conditions, although the proof of it may be indirect and difficult, and exact results quite unattainable. But with this point we have here no concern, and only say that it is no business of Science if the law be found to pervade domains of thought which Philosophy has hitherto claimed to be exclusively her own. Nor is there any just ground for arraigning men of science as transgressing the proper limits of their inquiries by pursuing the principle of the conservation of energy into

the spheres of life, mind, and social activity. Science could not evade the necessity of entering upon the earlier steps of the investigation, any more than it can now evade the necessity of pursuing it; and it would be a worthier proceeding on the part of philosophers, gratefully to accept what she contributes for their use, rather than to raise an outcry against the scientists for interfering with matters which, it is assumed, do not belong to them.

---

ANOTHER "SPENCER-CRUSHER."

THE work of putting down Herbert Spencer, which has been going on these dozen years, still flourishes and threatens to become a regular occupation. Obscure men are making reputations right and left, and famous men are adding to their laurels by taking down the great philosopher on all sides. If they do not succeed in getting him out of the way, this branch of criticism may grow into a thrifty business. Who shall be greatest in this little but increasing kingdom of criticism, it is as yet premature to say, although symptoms of gradation in the honors of the work are beginning to be disclosed. We explained, some time since, in the MONTHLY, that our friend Liefchild had brought forth a big book, which was evidently designed to interrupt Mr. Spencer's philosophical career. He did not, however, himself aspire to the distinction of wiping him out, but assigned that high function to President Porter, of Yale, whom he ranked as the great "Spencer-crusher." Mr. Liefchild would probably accord to others the minor grades of extinguishers, upsetters, depressers, etc. Meantime the work may be expected to proceed vigorously. Although we often hear that Mr. Spencer has at last been quite demolished and put an end to, he seems to be still alive and in a very vigorous condition, as the article replying to the *Quarterly* Reviewers in our present number will

attest. The last aspirant for glory, in the Spencer-crushing line, is one Alexander Gibson, hitherto guiltless of fame, whose onslaught is contained in a late number of the *London Academy*. This periodical, it may be remarked, was started a few years ago, with an Oxford parentage, as an organ of old rubbishy scholarship and useless lore generally, and, having been knocked about among different publishers as a bad speculation, now turns up in new hands, and the transition is signalized by the present essay at the use of the critical scalping-knife.

Conscious, perhaps, of the trouble he has been causing to the critical fraternity, Mr. Spencer has lately changed his tactics. In his former works he expressed his own opinions very freely on various subjects, and it is these that have been the objects of attack by the increasing crowd of his assailants. They have shown, in a manner perfectly conclusive to themselves, that his views are weak, foolish, erroneous, false, absurd, dangerous, and wicked. And so he has now made a book containing no opinions of his own at all. It is a work simply of facts and authorities, and, as if scrupulously to avoid rousing the ire of his enemies, he hired a man to write out the facts and copy the authorities. His own agency was limited barely to drawing up a plan of presentation, which his assistant was to follow, and he indulges in not a word of comment upon the statements that are made. But all in vain. Alexander Gibson hunts him out, even in this city of refuge, and is bound to crush him all the same. Let us gather up the fragments, and see what remains after this last assault.

In reviewing the "Descriptive Sociology" in the *Academy*, Mr. Gibson makes two points, which are—*first*, that the compilation of facts by Spencer's assistant, Mr. Collier, is badly done; and, *second*, that, if it had been well done, the work would still be good for nothing.

Mr. Gibson begins by a representation that is quite misleading. He says: "It is clear at a glance that the work thus undertaken is one of great magnitude and difficulty; and, when one considers the high reputation Mr. Spencer has acquired by his sociological theories, it acquires a peculiar interest, as it will serve to show the nature and value of the material which he has used for constructing or testing his speculations." The implication here is, that Mr. Spencer has first theorized and speculated upon social questions, and then sought for facts to support his views. But Mr. Spencer's social philosophy has never yet been developed, and the collection of sociological data which was commenced five years ago is designed as the foundation for general principles yet to be derived from them. The relation of these materials to the uses for which Mr. Spencer himself proposes to employ them cannot therefore be judged until his principles of sociology are worked out. Mr. Gibson inverts the truth of the case, for Mr. Spencer's extensive collection and classification of facts were not made to sustain past speculations but as a guide to future theories.

In judging of his undertaking, it is important to remember that Mr. Spencer published first that division of it which is most open to criticism; that is, he deals first with the social elements of his own country, the history of which is generally familiar. It is also not to be forgotten that his aim was to bring forward just that order of facts for which historians have cared the least, and concerning which their statements have been most loose, careless, and conflicting. Added to this, the work of collection and arrangement had never before been attempted, and Mr. Spencer had to work as a pioneer in the field. It is also noteworthy that the plan of the work precluded all explanatory comment. That such a work—a work of "great magnitude and

difficulty," as Mr. Gibson allows—cannot be free from errors is obvious, and from all the foregoing causes it is peculiarly exposed to unscrupulous criticism. When these considerations are taken into account, Mr. Gibson's case of alleged errors in the tabular statements on the part of Mr. Collier is simply pitiful. His six-column search for flaws and defects yields the following outcome.

Mr. Collier enters his numerous and varied facts in their proper relations in the tables in the most condensed language possible, as he was compelled to do by the nature of the presentation; but this, of course, affords Mr. Gibson an opportunity, which he duly improves, to complain of the want of explanations. For the classified facts Mr. Collier gives in the accompanying text the exact words of the authorities which he has followed, and Mr. Gibson has no admiration for disjointed "scraps." Mr. Collier has made quotations from about one hundred and seventy works, which were of course sought as the best, and which the intelligent reader will see comprehend the great mass of authentic English history, Mr. Gibson impeaches none of these authorities, but sublimely discredits the whole, declaring that they "are not, in the historical sense of the word, authorities at all." This, of course, is mere assertion. The "historical sense" can be nothing else than common-sense applied to history, and that can only require the compiler to seek the best possible sources of information. If the regular historians have failed to furnish it, it must be gathered from other and scattered sources. Mr. Spencer's tables give strong evidence of being a faithful reflex of the social state. They are full of gaps where information could not be supplied; and the best authorities extant have been diligently searched for the statements, names and pages being carefully given; what more

can be reasonably asked? Although he does not attempt to show wherein the authorities are untrustworthy, he tries to make out three or four instances in which the quotations are insufficient to justify the statements based upon them in the tables. Again, he says there is no clear trace that he (Mr. Collier) has any perception of the relative value of the different facts he has come across in the one hundred and seventy volumes which he has consulted. It is but just to Mr. Collier to say that, while he has *quoted* one hundred and seventy volumes, he has *consulted* a far larger number, and it is a sufficient reply to Mr. Gibson's insinuation regarding Collier's defective "perception" of the relative values of his facts, that their valuation was not his business, and if some are more valuable than others he could not very well help it. Mr. Spencer has pointed out in his preface the difficulty of reducing such multifarious details to a tabular statement in parallel columns, while the advance of society constantly gives rise to new elements. The exigencies of the classification required that, to a certain extent, diverse though kindred facts should be grouped together. But this does not protect him from the hypercritical Gibson, who carps at the distributions, and thinks that "most of the information under the head 'Morals' ought to be transferred to the heading of 'Law and Politics;'" while the diversity of objects that Mr. Collier has included under the head of "Tools and Implements" is gravely pointed out in the array of objections. Of Mr. Collier's omissions this keen-eyed critic has discovered one which he duly chronicles: it is the failure to mention "dramatic poetry." Mr. Gibson is captious over the deficiency of the statements, and thinks that more facts are wanted. He says: "It would be the merest impertinence for Mr. Spencer's sociological student to draw conclusions from such miserable data

as, for example, are afforded, in the case of English religious ideas and superstitions from the Druids to the Gorham controversy, within the limits of seven columns an inch wide." Yet, in these seven long columns of compressed statements, with the copious authenticating extracts, there is a vast amount of valuable (though we suspect to Mr. Gibson), of unpalatable information, as he returns to them again and again with unhappy comments. But it is to be remembered that Mr. Spencer is far from proposing to formulate a sociological science on the basis of English experience alone. The plan of his work embraces all types and grades of the social state, and is so comprehensive that its complete publication is still a matter of question. Mr. Gibson's complaints at the paucity of the materials are, therefore, quite gratuitous.

Such is the quality of Mr. Gibson's critical work. It is approached in an ugly temper, and, a few petty inaccuracies and defects being found, the most absurd charges are made and the whole work declared unworthy of confidence. The complete break-down of his case, so far as Mr. Collier is concerned, affords excellent evidence of the judgment and fidelity with which the task has been executed.

Mr. Gibson's second point is that, "even supposing that Mr. Spencer had got them (the tables) done with as great accuracy and intelligence as possible, they would still be useless." But why expend so much vicious ingenuity in finding defects in an intrinsically worthless thing? One would naturally suppose that this second point would have been taken up first, because, if established, the former inquiry would be superfluous. But, if we ask for the reasons of this position, Mr. Gibson wisely declines to give them; only remarking that "we have had too much already of the tendency, on the part of framers of social and other sciences, to deal superficially with history." By

the framers of sciences, we suppose that Mr. Gibson can only mean those cultivators of science who originate and organize this kind of knowledge, and the upshot of his charge, therefore, is that the scientific method of studying history is superficial. This raises the question, "What are the depths, and what the shallows, of history?" Of the descriptive sociology, one of the most eminent authorities in England, Mr. E. B. Tylor, writes in *Nature*: "So much information, encumbered with so little rubbish, has never before been brought to bear on the development of English institutions." Is it the information concerning the "development of English institutions" that is the superficial element? and is it the "rubbish" that constitutes the profound element wanting in Mr. Spencer's plan? There are two methods of dealing with history: the old method of chronicle, narration, and story-telling, which was in vogue before science arose; and the later or scientific method, which aims at the discovery of natural laws among historic phenomena. The old method occupied itself with the registration of surface effects, and whatever happened to be uppermost and obtrusive in any place or period. It was a biography of the conspicuous figures that chanced to emerge and occupy passing public attention. It was full of the doings and sayings of sovereigns, generals, diplomatists, and politicians; full of their gossip, rivalries, and crimes; the details of war, the quarrels of factions, and the intrigues of ambitious families; and it has consisted of so chaotic and incoherent and interminable a mass of details of this sort, that its cultivators scout the idea that there is or ever can be any thing like a science of history. This, we suppose, is to be taken as the deep part of the subject—its profundity being due to the fact that it cannot be reduced to order? On the other hand, science, which has disclosed the opera-

tion of law throughout all the workings of Nature, has entered with its new method upon the study of society. In what does the social structure consist? what are the nature and laws of its activities? what are the conditions of its development? These are its problems. Science always begins with the observation, determination, and classification, of facts. This is its first solicitude. To get at the facts with the highest certainty and the greatest exactness and fullness that are possible, is the primary and inexorable duty of the true scientific inquirer. To put these facts in their proper relations, so as to draw from them the principles and laws by which they are governed, is the essence of scientific method, and to this Mr. Spencer has rigorously conformed by devoting a separate and extensive work to the systematized data that are necessary for valid reasoning upon social subjects. All this, says Mr. Gibson, is of no use, because, if it is "done with as great accuracy and intelligence as possible," it is still worthless from its superficiality. And so, court frivolities and the trumperies and trivialities of personal incident are the deep things for which the "historical sense" must make research, while the investigation of principles and laws is the worthless work of shallow scientists! That will do for Mr. Gibson. Let him return to his dust-holes and rubbish-bins, and enjoy their obscurities and confusions as the profundities of history. We should not have meddled with him on his own account, but Mr. Spencer's work is a challenge to his party, and we were interested in seeing what they would do about it. Their champion has done the best and the only thing that he could, and that is to merge his attack upon Spencer into a final assault upon science itself.

---

We reproduce on another page the brief but suggestive address of Mr.

George Ripley, upon laying the cornerstone of the new *Tribune* building. It was fitting that the paper which was founded by Mr. Greeley, and devoted to progressive ideas, and which has had so wide an influence in educating the American people, now that its founder and master-spirit has passed away, should be solemnly rededicated to the continued advance and diffusion of liberal thought and growing knowledge. A political partisan press we must, undoubtedly, continue to have, just as we must have war, pestilence, crime, corruption, and other evils; but it is coincident and will be coterminous with public ignorance, shortsightedness, and the general reign of demagogism. We accordingly hail with pleasure every indication of revolt against party domination, and the increasing recognition of those wider and deeper interests with which the permanent prosperity of society is involved. In the diffusion of science in cheap popular forms, the *Tribune* has always taken a leading part; and its recent efforts in this way add strength to the pledge now offered, that the same policy will be pursued in the future. In a few compressed sentences Mr. Ripley happily sketches the recent movements of philosophic thought, and discerns the full significance of that latest and largest synthesis of ideas to which scientific inquiry has brought the foremost minds of the age. Nothing is more significant of positive intellectual advance than to see a great newspaper, immersed as it must be in the practical concerns of daily life, yet holding its course in the world of thought by the higher lights of science and philosophy. The career and character of this journal have undoubtedly been, in a large measure, determined by the active mind of Mr. Greeley; but no estimate of its public influence would be just that should omit the prolonged and distinctive labors of its able literary editor, now president of



the *Tribune* Association. For twenty-five years Mr. Ripley has interpreted the intellectual work of the age through its columns to millions of his countrymen; and this has not only been done with conscientious fidelity and rare discrimination, but with a broad and courageous liberality and a catholic sympathy with all that seemed true and excellent, whatever its source. May the paper, in the new epoch upon which it has entered, have all the success that shall be commensurate with its nobleness of aim, and its honorable and high-toned management!

---

DEATH OF DR. LIVINGSTONE.

TI DINGS of the death of Dr. David Livingstone, the celebrated African explorer, have been received, and are generally credited. The particulars are meagre and uncertain, but it is said he died of dysentery after severe exposure, returning from Ujiji to Unyanyembe. The expedition of the British Government, under Lieutenant Cameron, is supposed to have met him in an encampment where he breathed his last, and embalmed his body to be taken to Zanzibar.

He was born in 1817, of poor Scottish parents, and, having a taste for books, his father helped him to attend the Glasgow University in the winter, while he helped himself by working in the cotton-mills in vacation. He studied medicine, and was admitted to general practice in surgery and physic in 1838. He desired to go to China as a missionary, but, hearing that a medical agent was wanted for the African missions, he applied, was accepted, ordained to preach, and in 1839 left for Natal. He here met the missionary, Rev. Mr. Moffatt, and married his daughter, by whom he had two sons born in Africa. His first effort at exploration was in the great Kalahari Desert in 1849, when he discovered the

Zonga River, and floated down its current into Lake Ngami, the most southerly of that great chain of lakes which occupies the centre of Africa. The next year he returned to this lake with wife and children, who suffered greatly. He afterward discovered the great Zambezi River, the chief stream of Southern Africa. He now formed the scheme of opening up the Zambezi by means of light steamers, and of evangelizing the inhabitants of the region. His family were sent to Europe, and he undertook a formidable search of this country in 1852. His wanderings, adventures, and discoveries, were continued until the latter part of 1856, when he returned to Europe, and was received with the greatest honors. In 1857 he published a narrative of his travels, and in 1858 returned to Africa to explore the Zambezi with steam-launches. During this expedition he discovered Lakes Nyassa and Shirvan, lost his wife, and the expedition was recalled by the Government in 1863, and he again reached England in 1864. In 1865 he left his native country for the last time, and his object was thus stated in the preface to his book on the Zambezi and its tributaries: "I propose," he wrote, "to go inland north of the territory which the Portuguese in Europe claim, and endeavor to commence that system in the East which has been so eminently successful on the west coast—a system combining the repressive effects of her Majesty's cruisers with lawful trade and Christian missions—the moral and material results of which have been so gratifying. I hope to ascend the Rovuma, or some other river north of Cape Delgado, and, in addition to my other work, shall strive, by passing along the northern end of Lake Nyassa, and round the southern end of Lake Tanganyika, to ascertain the watershed of that part of Africa. In so doing I have no wish to unsettle what, with so much toil and danger, was accomplished by Speke and Grant, but



rather to confirm their illustrious discoveries."

Of his travels, explorations, sufferings, and adventures, during the last nine years, not much is yet known, but it is hoped that records will be found giving additional information concerning the geography of interior Africa.

#### DEATH OF FERNAND PAPILLON.

THE readers of the MONTHLY will be pained to learn of the recent and sudden death of this brilliant young writer, with several of whose masterly papers they have become acquainted in the pages of this periodical. He died January 2d, at the age of twenty-six, of an attack of acute peritonitis, the result of a cold contracted by attending the funeral of a friend. The son of a distinguished physician, he was born at Belfort, in 1847. He studied at the Colmar Lycée, and there acquired a taste for chemistry. He attended the chemical lectures of Würtz at the Collège de France; and, at the age of sixteen, he made full abstracts of the course, which were so well done, that Würtz sent the copy to the printer with scarcely any alteration. He was recommended by Prof. Würtz to the editor of the *Moniteur Scientifique*, and had been employed upon that journal since 1864. He pursued original work in chemical physiology, and discovered the possibility of substituting, in the bones of animals, phosphate of magnesia and of strontia for phosphate of lime. He has published several important papers besides those that have been reproduced in the MONTHLY, the most interesting of which will continue to appear in our pages. He was of very amiable disposition, strongly attached to his friends and teachers, and much beloved by all who knew him. His short career was in a remarkable degree successful, as he had attained a reputation and influence in France which is usually reached only by men

in the riper years of life. His papers are being prepared for the press in Paris, and will be also separately republished in this country.

## LITERARY NOTICES.

INTERNATIONAL SCIENTIFIC SERIES, NO. VII.

THE CONSERVATION OF ENERGY. By Dr. BALFOUR STEWART. With an Appendix on the Vital and Mental Applications of the Doctrine. 236 pages. Price, \$1.50. D. Appleton & Co.

WE speak, in another place, of the importance of the great principle of the conservation of energy as a fundamental truth of modern science. The literature of this subject has hitherto been copious, but, as it has been mainly the product of minds engaged with the original research, it has often been so technical and complicated as to be difficult to popular apprehension. The writers have generally been too busy with the investigation to give the needed attention to the art of familiar statement. No subject was in greater need of thorough simplification and careful elementary treatment. Dr. Balfour Stewart, the distinguished physicist of Kew Observatory, and Professor of Owens College, was solicited to undertake this task for the "International Scientific Series." This he consented to do, and, although master of the philosophy, and entitled to a place among its original investigators, he has shown that he can enter into the spirit and do the indispensable work of the pure teacher. His book has been written in the simplest language, with abundant and familiar illustrations, so that the ordinary reader, by its perusal, can get a complete understanding of the elements of the subject. His volume is quite remarkable for its clearness and the success with which it explains many of the hitherto difficult parts of the subject.

Dr. Stewart, as we have said, is a physicist, and he has wisely limited himself to the operations of the law, as disclosed in physical phenomena. But, to give completeness to the volume, an appendix has been added incorporating two able essays, by distinguished men who have studied the question in its vital and mental relations. Prof. Le

Conte has revised the essay, which appeared in the November MONTHLY, on the "Correlation of the Vital with the Physical and Chemical Forces," which is here reproduced; and an able lecture by Prof. Bain, on the "Correlation of the Nervous and Mental Forces," gives an instructive view of this branch of the subject. This little volume will therefore afford a fresh and complete exposition of the elements of the subject for the use of general readers.

ON THE ORIGIN AND METAMORPHOSES OF INSECTS. By Sir JOHN LUBBOCK, M. P., F. R. S. Illustrated. New York: Macmillan & Co. 1874. 108 pp., crown 8vo. Price, \$1.50.

SIR JOHN LUBBOCK is well known to the world as an archæologist and anthropologist, and perhaps less well as an entomologist. Yet he has contributed no less than *thirty-five* papers to the Royal Society, and to various magazines, on entomology, during the last twenty years; and, as he is not yet forty, we perceive that he must have studied the subject at a very early age. His first paper, "On Labidocera," appeared in the *Annals and Magazine of Natural History* for 1853.

The little work before us embodies, in a popular form, many of the more interesting results of his observations, condensed from the above-mentioned memoirs. The articles have already appeared in *Nature*, and the work forms the second volume of the "Nature Series" of books, which Messrs. Macmillan are now publishing.

The main subjects discussed are the classification, origin, and the nature of the different metamorphoses of insects; various views are traced, from the old standard "Entomology" of Kirby and Spence, one of the Bridgewater Treatises, to the more recent memoirs of Müller, Agassiz, and Packard. The intelligence of insects comes out in a remarkable light. Many of our readers will remember Sir John's tame wasp at a recent meeting of the British Association. He remarks: "We are accustomed to class the anthropoid apes next to man in the scale of creation, but, if we were to judge animals by their works, the chimpanzee and the gorilla must certainly give place to the bee and the ant." For example (page 2), the larvæ of certain insects require animal

food as soon as they are hatched, and the mother-insect consequently provides them with caterpillars and beetles, by burying them in a cell, side by side with the unhatched larva. But here a difficulty arises: "If the *Cerceris* were to kill the beetle before placing it in the cell, it would decay, and the young larva, when hatched, would only find a mass of corruption. On the other hand, if the beetle were buried uninjured, in its struggles to escape it would be almost certain to destroy the egg." Look, then, at the wonderful, but diabolical, instinct of the creature. "The wasp has the instinct of stinging its prey in the centre of the nervous system, thus depriving it of motion, and let us hope of suffering, but not of life; consequently, when the young larva leaves the egg, it finds ready a sufficient store of wholesome food." A certain species of ants keeps *Aphides* in bondage, just as we do cows, for the sake of the honey-dew which they collect; a certain kind of red ant is indolent, and keeps black ants to do work for it. Once more, there is a kind of beetle which is blind and helpless, usually found in ants' nests; the ants care for all their wants and nurse them tenderly. These things, and much more, of the lives of insects, are told us in popular language in Sir John's book, which we recommend, not alone to the entomologist, but to the general reader.—*Quarterly Journal of Science*.

HENSLOW'S BOTANICAL CHARTS. Revised and adapted for Use in the United States. By ELIZA A. YOUMANS. Mounted on Rollers. Six in Number. Price, \$18.00.

THE botanical diagrams of the late Prof. J. S. Henslow, of Cambridge University, have long had a high reputation in England for their scientific accuracy, their completeness of illustration, and their skillful arrangement for educational purposes. They consisted of nine large sheets, and were published by the Science and Art Department of the English Educational Council. After bringing out her method of elementary botany in the First and Second Books, Miss Youmans felt the need of large colored illustrations of the subject; and, as Henslow's series was the most valuable yet prepared in any country, and too expensive to

import, her publishers were induced to bring out a revised edition of them here. The English edition was defective from excessive compression, the figures often overlapping so as to produce a confused effect. In the American edition they are spread over twice the original surface, giving them much greater clearness for class-room use. Several American specimens have been substituted for English species which do not occur in this country, and the whole arrangement has been much improved.

These charts illustrate the principles of the whole science of botany. They represent twenty-four orders, and more than forty species of typical plants with all their details of structure, in such a way as to exemplify the complete organization of the science. Each specimen is first shown of its natural size and colors, then a magnified section of one of its flowers is given, showing the relations of the parts to each other. Separate magnified views of the different floral organs, exhibiting all the *botanical characters* that belong to the group of which it is a type, are also represented. All varieties of botanical structure, in leaf, stem, root, inflorescence, flower, fruit, and seed, are thus exhibited. The charts contain nearly 500 figures, colored to the life, and their purpose is not to supersede the study of living plants, but only to facilitate it. Minute parts which are often difficult to find are represented upon an enlarged scale, and thus become a guide to the study of the plant.

In her Second Book, Miss Youmans says: "Besides this special assistance in object-study, the charts will be of chief value in bringing into a narrow compass a complete view of the structures and relations of the leading types of the vegetable kingdom. In fact, they are designed to present, fully and clearly, those groupings of characters upon which orders depend in classification, while, in several cases of large and diversified orders, the characters of leading genera are also given by typical specimens. The charts will thus be found equally valuable to the beginner, the intermediate pupil, and the advanced student." A key accompanies the charts, and they can be used with any botanical text-books; and, during the season of plants, they

should be upon the walls of every school-room where botany is studied.

ON INTELLIGENCE. By H. TAINÉ, D. C. L., Oxon. Translated from the French by T. D. Haye, and revised with Additions by the author. New York: H. Holt & Co. Pp. 553. Price, \$5.

THE writings of M. Taine on art, literature, and science, have taken a high rank in Europe and in this country. Though his genius may, in strictness, be said to be artistic rather than purely scientific or philosophical, yet, in the work before us, he has shown not only a varied knowledge of the details and specialties of the sciences, but an admirable aptitude in collocating and generalizing their doctrines.

All speculation, to have any permanent value, must be based upon the natural order of things: it must be interwoven with matter, motion, and force. When the intelligence becomes a faithful mirror, and reflects the universe as it is, weighing and measuring it, real progress in thought is inevitable. Well-observed and well-digested facts, thorough and patient experiments, drawn along the varied lines of Nature, generate new and recast old ideas which open out a fresh intellectual life between the two great factors of science, man and the cosmos.

We do not claim for M. Taine any noticeable discoveries in the realm of natural facts, through either observation or experiment; but we claim that he has enriched us with many new ideas and a wealth of expression very rarely equaled. His recondite thoughts are clothed in beauty by a most exquisite imagination.

M. Taine has divided his labor into two parts, containing eight books and eighteen chapters. The first two books, on "Signs and Images," are relieved of much of their necessary subtilty by the picturesque and realistic manner of their treatment. His words are never void of the kernel of the concrete, which is never overshadowed by abstractions. The various objects of the external world and their permanent relationships are physiologically gathered up by the five senses, and require to be properly named or labeled before entering into the laboratory of thought. For this purpose signs are deftly woven together and become indispensable as servants of the mind. This

may be called the art of naming. The accumulated materials of the senses are, through a certain chemistry of the nerves and brain, photographed as *images* on the mind, and these enable us, through the means of *signs*, to dissect and put into logical sequence the whole order of Nature. What we have in our minds, says M. Taine, when we conceive general qualities and characters of things, are signs and signs only. Signs or words, therefore, branch out of sensations, and, to be of real value in the organization of knowledge, these must originate from healthy and well-regulated senses and sound cerebral functions. The immutability of the external order of things in Nature is the only sure corrective of all the aberrations and errors to which the internal condition of man, as a reflecting medium, is subject.

Books III. and IV., concluding the first part, treat of sensations and of the physical conditions of mental events. In the discussion of these topics M. Taine is fortified by the leading writers of France, England, and Germany, to whose important authority he adds much original thought, and unties many a perplexing knot by his well-directed and practised ingenuity. In the second part of his work, M. Taine treats, in the first book, of the general mechanism of knowledge; in the second, of the knowledge of bodies; in the third, of the knowledge of mind; and in the fourth book, of the knowledge of general things.

**MEN AND APES**; an Exposition of Structural Resemblances and Differences, bearing upon Questions of Affinity and Origin. By ST. GEORGE MIVART. New York: D. Appleton & Co., 1874. Price, \$1.50.

MR. ST. GEORGE MIVART, best known as an opponent of Darwinism, strictly so called (but not of evolution), has in this work examined into the relations of man and the apes as well as other primates. In a first chapter, he gives a summary of the "external forms, habits, geographical distribution, and classification," of the primates; in a second, the "external skeleton (skin and hair) and internal skeleton (the bones)" are examined; and the last or third chapter is devoted to the consideration of the "nervous system, visceral anatomy, summary of characters, and questions of affinity and origin." He admits, with all competent

naturalists, that man is most nearly allied to the apes, that is, the group composed of the gorilla, chimpanzee, orang-outang, and gibbons: the difference, then, between Mr. Mivart and others is as to the special form of apes that man is most allied to. In order to solve this question, he successively recapitulates the characters common to man and the several forms referred to, as well as the main points of difference. His results are rather negative than positive: he entirely rejects the claim made on behalf of the gorilla to nearest kinship, but does not positively claim such rank for any of the other forms, although evidently disposed to regard the affinity at least as great between the gibbons and man as with any of the other forms; he is more reserved, however, in this respect than on a former occasion. Adopting the general theory of evolution, he applies it, so far as the *body* is concerned, to man, but he claims that in his case a specific *creation* has been manifested by the endowment of that body with a *soul*.

**A DICTIONARY OF MEDICAL SCIENCE, WITH THE ACCENTUATION AND ETYMOLOGY OF THE TERMS, AND THE FRENCH AND OTHER SYNONYMS.** By ROBLEY DUNGLISON, M. D., LL. D. Enlarged and thoroughly revised edition, by Richard J. Dunglison, M. D. Philadelphia: Henry C. Lea, 1874.

FOR forty years this work has been an accepted authority in the hands of the profession, both here and in England. It was originally made in obedience to the demand created by the rapid advance of medical science, and how well it fulfilled its intended purpose is attested by its long and steady popularity. The present edition—the preparation of which was begun by the author, but, owing to his death, was finished by his son—is much enlarged, including more than six thousand subjects and terms not embraced in the last, and making altogether over a hundred pages of new matter. The book is something more than a dictionary. Besides the derivation, pronunciation, synonymy, and technical definitions of medical terms, it gives, under the appropriate heads, a large amount of valuable practical information which, from its conciseness and ready accessibility, cannot fail to be of great service to the physician. The typographical arrangement has also

been somewhat changed, heavy type being employed for the leading terms, while synonyms and subordinate words are put in small capitals—a modification which affords greater facility of reference. Taken as a whole, the work is much superior to any other of the kind we know of in the language, and no medical library can be considered complete without it.

**SCHEM'S STATISTICS OF THE WORLD.** Edited by Prof. ALEXANDER J. SCHEM. New York: G. J. Moulton, 1873.

THIS is a semi-annual publication, giving the facts and figures of the world's affairs, boiled down even to the point of desiccation. The matter is arranged in the form of tables, giving, for each country, its area, the name of its present ruler, population, debt, army and navy, imports and exports, products, coin values, weights and measures, capitals, and principal cities, together with railway, educational, and religious statistics. The facts, we are told, are collated from the latest reports, and the method of presentation, so far as convenience is concerned, appears to be a good one. With all its concentration, however, we notice some apparently needless repetitions. For example, after giving a list of the successful presidential candidates in the United States, from the foundation of the government, with the vote cast for each, their names are given over again on another page, with the State they were from, and the time of service of each, information which might more properly have gone into a single table. An excellent feature is the comparison of the weights and measures of each country with the French and English standards; their coin-values are also given in dollars and cents.

#### PUBLICATIONS RECEIVED.

On the Early Stages of *Terebratulina Septentrionalis*. By Edward S. Morse, Ph. D. 10 pages, with Illustrations.

Transactions of the American Society of Civil Engineers. November, 1873. 48 pages.

A Description of New Instruments for making Examinations and Applications to Cavities of the Nose, Throat, and Ear. By

Thomas F. Rumbold, M. D. St. Louis, 1873. 16 pages, with Illustrations.

Bulletin of the Buffalo Society of Natural Sciences, vol. i., No. 3, pages 129-184. Illustrated.

The Function of the Eustachian Tube. By Thomas F. Rumbold, M. D. St. Louis, 1873. 40 pages.

Second Biennial Report of the San Francisco Park Commissioners for 1872-'73. San Francisco, 1874. 94 pages. Illustrated.

On the Structure and Affinities of the Brontotheridæ. By Prof. C. C. Marsh. 8 pages. Illustrated.

Johnston's Dental Miscellany. A Monthly Journal of American and Foreign Dental, Surgical, Chemical, and Mechanical Literature. New York, January, 1874, vol. i., No. 1, 38 pages.

On the Geology of Western Wyoming. By Theo. B. Comstock, B. S. 8 pages.

Transactions of the Michigan State Medical Society. Lansing, 1873. 170 pages.

The Larynx the Source of the Vowel Sounds. By Thomas Brian Gunning. New York, 1874. 29 pages.

---

## MISCELLANY.

**England and America.**—Prof. Tyndall writes as follows to the editor of the *Daily Telegraph*: Sir—You have given me a challenge, to which I willingly respond. In a speech, to which I had the honor of listening just before my departure from America, Hon. William M. Evarts used these words: "There is a generous and perfect sympathy between the educated men of England and the educated men of the United States. The small matters of difference and political interests which divide these two great countries are nothing to the immense area of uniform and common objects and interests which unite their people."

On the same occasion, Dr. John W. Draper, celebrated alike as an historian and scientific discoverer, concluded a speech in these words: "Nowhere in the world are to be found more imposing political problems than those to be settled here—nowhere a greater need of scientific knowledge. I am



not speaking of ourselves alone, but of our Canadian friends on the other side of the St. Lawrence. We must join together in generous emulation of the best that is done in Europe. In her Majesty's representative, Lord Dufferin, they will find an eager appreciation of all that they may do. Together we must try to refute what De Tocqueville has said about us, that communities such as ours can never have a love of pure science. But, whatever may be the glory of our future intellectual life, let us both never forget what we owe to England. Hers is the language which we speak, hers are all our ideas of liberty and law. To her literature, as to a fountain of light, we repair. The torch of science that is shining here was kindled at her midnight lamp."

The President of Cornell University, to which Mr. Goldwin Smith belongs, used, on the same evening, these remarkable words: "We are greatly stirred, at times, as this fraud or that scoundrel is dragged to light, and there rise cries and moans over the corruption of the times; but, my friends, these frauds and these scoundrels are not the corruption of the times. They are the mere pustules which the body politic throws to the surface. Thank God that there is vitality enough left to throw them to the surface. The disease is below all this, infinitely more wide-spread. What is that disease? I believe that it is, first of all, indifference; indifference to truth as truth; next, skepticism, by which I do not mean inability to believe this or that dogma, but the skepticism which refuses to believe that there is any power in the universe strong enough, large enough, good enough, to make the thorough search for the truth safe in every line of investigation; next, infidelity, by which I do not mean want of fidelity to this or that dominant creed, but want of fidelity to that which underlies all creeds, the idea that the true and the good are one; and, finally, materialism, by which I do not mean this or that scientific theory of the universe, but that devotion to the mere husks and rinds of good, that struggle for place and pelf, that faith in mere material comfort and wealth, which eats out of human hearts all patriotism, and which is the very opposite to the spirit which gives energy to scientific achievement. . . . I believe that the little

army of scientific men furnish a very precious germ, from which better ideas may spring; . . . and I trust that love, admiration, and gratitude, between men of science on both sides of the Atlantic, may add new cords and give strength to old cords which unite the hearts of the two great English-speaking nations."

On the same occasion, in reference to the question of international amity, I ventured to say this much: "Among the motives which prompted me, at the time of accepting your invitation, was this: I thought, and friends of mine here thought, that a man withdrawn from the arena of politics, who had been fortunate enough to gain a measure of the good-will of the American people, might do something toward softening political asperities. I referred to this point in Boston, but my references to it have grown more and more scanty, until, in the three cities last visited, they disappeared altogether. And this not because I had the subject less at heart, but because, as your great countryman, Emerson, might express it, any reference of the kind would be like the sound of a scythe in December, entirely out of place. During my four months' residence in the United States I have not heard a single whisper hostile to England."

This, sir, will sufficiently indicate to you my experience of the feeling of the people of the United States toward this country. Either they do not hate us, as alleged; or, if they do, the manner in which they suppressed this feeling, out of consideration for a guest, proves them to be the most courteous of nations.

I am, sir, your obedient servant,

JOHN TYNDALL.

ATHENÆUM CLUB, *Saturday, Jan. 17th.*

**Population of New Guinea.**—Captain C. J. Moresby, of the British Navy, who visited New Guinea during the past year, to complete the unfinished survey of the late Captain Owen Stanley, reports that the whole coast country of the eastern half of that island is well peopled with a copper-colored race, quite distinct from the black Papuans of the western portion. This lighter-colored race are a friendly and intelligent people. They gladly received their strange visitors at their villages, and the crew of Captain



Moresby's vessel mixed freely with them. They practise several useful arts, such as pottery, and possess extensive well-fenced plantations.

Several attempts were made to reach the mountainous interior, by ascending the rivers emptying into Redscar Bay, but the boats were in every case brought to a stand by the increasing velocity of the current, after the first thirteen or fourteen miles. Farther east a fine port and inner harbor were discovered, and named Port Moresby and Fairfax Harbor. The southeastern extremity of New Guinea was found to have the form of a fork, off the lower tine of which lies a group of islands, but leaving a deep navigable channel between them and the main-land. Captain Moresby doubled the northern extremity of the fork, and found the northern coast of New Guinea washed by a grand, clear, reefless sea. The natives here were of the same Malayan or Polynesian race as those of Redscar Bay, and the hill-slopes near their villages were terraced and cultivated to a great height, in a manner that even a Chinaman might envy. With these people the intercourse of Captain Moresby's men was of a most satisfactory, pleasant nature. Pieces of hoop-iron were the medium of exchange, with which the crew purchased food and curiosities, including specimens of their handsome stone hatchets.

*Prof. E. L. Youmans—*

MY DEAR SIR: Be so kind as to allow me room for a word in relation to the article "The Great Cemetery in Colorado," in the last number of this magazine. It was already in print when my attention was called to Prof. O. C. Marsh's article in the *American Journal of Science and the Arts*, "On the Structure and Affinities of the Brontotheridæ," in which the professor says of *Symborodon* and *Miobasileus*: "Both names should be regarded as synonyms of *Brontotherium*." While I would avoid as sheer officiousness the intrusion of one word as arbiter, yet I cannot permit the apparent discourtesy to rest upon me of even so much as seeming to ignore the professor's statement. I suppose that Prof. Marsh is entitled to be regarded as the discoverer, in 1870—and pioneer explorer then and in 1872—of that wonderful burial-place, whose dry

bones you did me the honor to assign the task of imbuing with enough of life to make them presentable to your many readers. Hence any thing from Prof. Marsh on that theme is worthy of far more than ordinary consideration.

Let me here correct a typographical error. In my article, on page 475, the first word in line twelve from the bottom of the page, "Eobasileus" should read "Miobasileus."

Very respectfully yours,

SAMUEL LOCKWOOD.

January 24, 1874.

**Autopsy of Agassiz.**—Autopsy by Drs. R. H. Fitz and J. J. Putnam; present, Drs. J. B. S. Jackson, J. Wyman, C. Ellis, M. Wyman, S. G. Webber.

Frame large. Fatty tissue abundant. Cranium, brachycephalic, falling off abruptly from the middle of the sagittal suture. Greatest antero-posterior diameter, 197 millimetres; greatest lateral diameter, 163 millimetres—these measurements made before the removal of the skin. Depth of frontal bone, measured externally at the median line,  $5\frac{1}{2}$  inches = 135 millimetres; length of sagittal suture, 5 inches = 128 millimetres. The walls of the skull were thick and heavy; the dura mater exceedingly adherent to the bone and remarkably thick. The pia mater moderately transparent. Along the arachnoid veins were white lines indicating chronic thickening; the veins themselves rather more injected than usual. The cerebral sulci were deep and wide. On each side of the median line, near the anterior ascending convolution on the left, and the posterior ascending convolution on the right, was a depression which might have held a prune-stone or a little more. The brain-tissue around was diminished without evidence of disease. The arteries at the base of the brain showed evidence of extensive chronic disease of their lining membrane, with narrowing of the calibre of the carotids. The basilar artery was apparently a continuation of the left vertebral alone, the right vertebral being represented by an exceedingly small vessel which united the basilar with the inferior cerebellar, the latter being merely the prolongation of the exceedingly small right vertebral. The left vertebral was larger

than usual—larger even than the basilar. In these unusually-arranged arteries were very important changes. Commencing at an inch below the anterior edge of the pons Varolii and extending downward, the walls of the left vertebral artery were stiff, in part calcified, and its linings loose. At half an inch from the point just mentioned, immediately over the left olivary body, was a reddish - yellow, opaque, friable plug (thrombus), completely obstructing the vessel; still lower was another more recent, but probably *ante-mortem* plug. The first was one quarter of an inch long, the second four inches long. A third plug, an inch long, was above the first, and touching it. Opposite the middle of the pons there was atheromatous degeneration of the basilar artery. The walls of the internal carotids were also in part calcified. The posterior part of the right cerebellar lobe (the side on which the vertebral artery was exceedingly small) was softer than usual, the corresponding foliations swollen and indistinctly defined, indicating disease of this part, probably consequences of the changes in the arteries.

The weight of the entire brain was 53.4 avoirdupois ounces = 1,495 grammes; allowing a diminution in the weight of the brain, from the age of thirty-five or forty years, at the rate of one ounce avoirdupois for each ten years elapsed, the greatest weight of the brain may be estimated at 56.5 avoirdupois ounces.

Weight of right anterior lobe (separated with the fissure of Rolando for a guide), 234 grammes; weight of left anterior lobe, 233 grammes. Heart large, muscular fibre firm and of good color. The attached portion of the aortic valves rigid, the mitral opening large. In the left ventricle, at the lower third, a firm, organized clot of the size of a peach-stone, attached to the wall at the anterior portion near the septum; around this clot a more recent one had formed, its centre softened and granular. From this, probably, some small portions had been carried by the blood to the arteries in the base of the brain, doing their part in obstructing them and causing the fatal changes above described. The lining membrane of the heart, where the clot was attached, was much thickened, and the

muscular layer at the same part very thin, near the apex not visible to the naked eye.

The lungs were adherent to the ribs on both sides of the chest—the evidence of old inflammations. The other organs were healthy.—*New York Tribune, December 16, 1873.*

**A Good Hedge-Plant.**—The *Gardener's Monthly* thinks that the white-thorn (*Elaeagnus parvifolius*) complies with all the conditions of a good hedge-plant, much better than the Osage orange or any of the other plants employed for that purpose in this country. This plant does not grow more than a few inches high the first year from seed, and is then thornless; but there are large numbers of short branches from a quarter of an inch to two inches in length, and these become sharp spines the next year. The older the plants the spinier they become—an excellent feature in a hedge-plant. The second and third years branches are produced from three to five feet long, thus soon reaching a good height for a hedge. When the plants are massed together, they rarely show any disposition to exceed the height of six or eight feet. When they reach that height, they grow by sending strong shoots out from the stems near the ground; and thus the hedge is ever growing thicker—another excellent feature. If pruned, they make a first-class hedge; if totally neglected, they are still protective. Plants three or four years old seed, so that in a few years, with moderate encouragement, plants in abundance could be obtained.

Besides its protective value, the plant has a very beautiful appearance. The under side of the leaf, as well as the young growing branches, are silvery; and hence its common name. South of the Potomac it would probably be an evergreen. In Pennsylvania it holds its leaves to Christmas. The flowers are greenish white, not showy, but resemble in fragrance the English hawthorn. The berries which succeed are of a mottled red. The writer in the *Gardener's Monthly* is unable to determine what is the extreme degree of cold to which the plant may be exposed without injury. He states, however, that it has remained entirely uninjured in one situation when

the last year's shoots of the Osage orange and the honey locust were destroyed, the thermometer being 14° below zero. The *Elæagnus* is a native of the Himalaya Mountains.

**Technical Education.**—Dr. Lyon Playfair, in his "Lecture on Technical Education," dwells upon the success which has attended the technical institutions of Switzerland and Holland. He says: "What has enabled this little nation (Switzerland), so remote from the pathways of commerce, and so poor in the mineral resources of industry, to carry on manufacturing production by the aid of a prosperous and contented people, while England, washed by the ocean and abounding in mineral wealth, is burdened with an ever-increasing proportion of the unproductive poor? There is only one answer: that Switzerland has a highly-educated people." And of Holland he adds: "Despite her natural poverty in the raw materials of industry, Holland sends to this country alone exports of food to the annual value of £5,000,000, and manufactured products worth £6,000,000 more. The law compels every town of 10,000 inhabitants to erect technical schools." Among Dr. Playfair's conclusions, he states that "a higher education, in relation to the industries of the country, is an essential condition for the continued prosperity of the people; for intelligence and skill—as factors in productive industry—are constantly becoming of greater value than the possession of native raw material or local advantages." —*Iron.*

**Science and the Press.**—Remarks of George Ripley at the laying of the cornerstone of the new *Tribune* building:

"FRIENDS AND FELLOW-LABORERS: We have assembled to-day in commemoration of the past, and for consecration of the future. The original foundation of the *Tribune* was laid in sentiment and ideas. Horace Greeley was a man of no less profound convictions than of lofty aspirations. The tenderness of his emotional nature was matched by the strength of his intellect. He was a believer in the progress of thought and the development of science, in the progress of society and the development of hu-

manity. Under the influence of this inspiration, the *Tribune* was established more than thirty years ago. At that time its basis was spiritual, and not material, strong in ideas, but not powerful in brick and mortar, in granite or marble, in machinery or in money. We have come to-day, not to remove this foundation, but to combine it with other elements, and thus to give it renewed strength and consistency. It is our purpose to clothe the spiritual germ with a material body, to incorporate the invisible forces which inspired the heart of our founder in a visible form, in the shape of a goodly temple, massive in its foundation, fair in its proportions, and sacred in its purposes. The new *Tribune* of to-day, like the old *Tribune* of the past, is to be consecrated to the development of ideas, the exposition of principles, and the promulgation of truth. The ceremony which is now about to be performed typifies the union of spiritual agencies with material conditions, and thus possesses a significance and beauty which anticipate the character of the coming age. The future which lies before us, it is perhaps not presumptuous to affirm, will be marked by a magnificent synthesis of the forces of material Nature and the power of spiritual ideas.

"Allow me one word in illustration of this prophecy, and I will yield the place to the fair hands and the fair spirit whose presence on this occasion crowns the scene with a tender grace.

"About ten years before the establishment of the *Tribune*, dating from the death of Hegel, in 1831, and of Goethe in the following year, the tendency of thought on the continent of Europe, which had been of an intensely ideal, or spiritual character, began to assume an opposite direction. Physical researches rapidly took precedence of metaphysical speculation. Positive science was inaugurated in the place of abstract philosophy. The spiritual order was wellnigh eclipsed by the wonderful achievements of the material order. A new dynasty arose which knew not Joseph, and the ancient names of Plato, and Descartes, and Leibnitz, were dethroned by the stalwart host that took possession of the domain of physical science. I need not rehearse the splendid discoveries which have

signalized this period. Such acquisitions to the treasury of positive human knowledge have never been made in an equal time in the history of thought. More light has been thrown on the material conditions of our existence on earth than has been enjoyed before since the morning stars first sang together. But the signs of the times indicate the commencement of a reaction. The age accepts the results of physical research, but refuses to regard them as the limit of rational belief. In resolving matter into molecules, and molecules into atoms, the most illustrious cultivators of physical science cheerfully confess that they arrive at invisible forces which no crucible can analyze, no microscope detect, no arithmetic explain. The alleged materialism of Tyndall and Huxley thus affords an unexpected support to the idealism of Berkeley.

"The *Tribune*, it may be predicted, will continue to represent the intellectual spirit of the age. Faithful to its past history, it will welcome every new discovery of truth. Free from the limitations of party in philosophy or religion, in politics or science, it will embrace a wider range of thought, and pursue a higher aim in the interests of humanity. Watching with its hundred eyes the events of the passing time, it will wait for the blush of the morning twilight which harbingers the dawn of a brighter day. As we now place the votive tablet on its rocky bed, let it symbolize the radiant scroll of human knowledge reposing on the foundation of eternal truth."

**A Swarm of Locusts.**—Dr. B. A. Gould, in a letter published in the December number of the *American Journal of Science*, describes a swarm of locusts at Cordova (in the north of the Argentine Republic), which, for extent, rivals those which have been sometimes witnessed in Eastern countries. He says: "I saw to the eastward what was apparently a long trail of dense black smoke extending over 160° of the horizon, from which it extended to an altitude of about 5°. The appearance differed in no respect from that of a black smoke drifting from a large conflagration. The insects were evidently transported by the wind, and passed within about three or four miles of us. Certainly twenty miles of its length

were visible over the far-stretching pampas. They were seen before ten o'clock in the morning, and continued to pass with apparently undiminished numbers until daylight failed."

In about eighteen days the phenomenon was repeated. They again appeared to move before the wind, and passed through the space between the traveler and the mountains, which were twelve miles distant, during many hours. The height of the dense nucleus seemed to be not less than 2,000 feet, its width about six or seven miles. "Since I began this page," says Dr. Gould, "they have come upon us in full force, literally darkening the sun, and there is probably not a square inch of our grounds unoccupied by them."

**Asphaltum Deposit in West Virginia.**—Prof. W. M. Fontaine published, in the December number of the *American Journal of Science*, an interesting account of a deposit of asphalt in Ritchie County, W. Va., which is extensively mined, and is valuable as an addition to the coal used in producing gas.

It occurs in an enormous fissure in the rocks, apparently filling it, and has been worked vertically through a depth of 300 feet, and horizontally through a distance of 3,315 feet. The fissure is seldom more than four feet wide, in many places much less, and narrows, in one direction, so much as to be unworkable. In another direction it ends abruptly at the valley of McFarland's Run,

The geological position of this fissure and deposit is in the "Upper Barren Measures," above the Pittsburg Bed, which contains no coal. These barren measures are of sandstones and shales, and are horizontal. They show no break except at the mines.

About seven miles in the direction of the crevice is the line of upheaval in which occur the oil-wells of West Virginia. And, as Prof. Fontaine observes, the bituminous deposits, which lie far beneath the surface, are doubtless the source of both the oil and the asphaltum.

In the cleft the mineral closely resembles ordinary bituminous coal, but at the sides adjoining the walls it is jet black, and has a brilliant lustre. The walls of the

crevice are seldom discolored more than an inch in depth, and the mineral adheres but slightly.

The dry dust of the mine is very inflammable, and two accidents from explosion have occurred. The asphalt contains about 76 per cent. of carbon, and yields about 100 gallons of oil per ton.

**Agassiz's Successor.**—It is rare that the mantle of the father sits worthily on the son. Especially is this true when the father has been signally eminent in pure science. Happily, indeed, is it for America, and for biological science, that the vast plans of the late Agassiz are to be continued, as far as possible, on the grand scale upon which his great mind projected them. The worthy successor of Prof. Agassiz is his son Alexander, whose name, in zoological investigation, is already acknowledged as a bright light in the Old World and the New. One of the most thoroughly worked-out monographs, so far as it is carried, and the most sumptuously gotten up, is the one recently published by Mr. Alexander Agassiz, containing his researches and memoirs on the Echinoderms, and which won for him the first award of the Walker prize of \$1,000, by the Boston Society of Natural History. Mr. Alexander Agassiz is to succeed his father in the conduct of the Penikese Normal School of Natural History. That great institution, the pride of Massachusetts, and the envy of the *savants* of the Old World, "The Museum of Comparative Zoology," at Cambridge, Mass., has been placed under the direction of Alexander Agassiz and Mr. Cary, "both of whom are thoroughly conversant with Prof. Agassiz's plans with regard to the museum, and familiar with the collections." Thus, while all must lament, as a great loss, the demise of that wonderful man, yet a deep solicitude has been removed from many minds as to the fate of the professor's plans.

**Lime-Soils and the Potato-Rot.**—A writer in the *Chemical News* is led, by analysis of diseased and sound potato-tubers, to ascribe the potato-rot to a deficiency of lime and magnesia in the soil. Different observers state the percentage of magnesia in the ash of sound tubers at from five to ten per

cent.; in the diseased tubers analyzed by the author it was only 3.94 per cent. Analysis of sound tubers shows over five per cent. of lime, but in the ash of diseased tubers the author found only 1.77 per cent. A similar observation was made some years ago by Prof. Thorpe with regard to diseased and healthy orange-trees; in the former there was a deficiency of lime and magnesia.

It was shown, by the late Dr. Crace Calvert, that lime is one of the few known substances that are capable of altogether preventing the development of fungi in organic solutions. He does not give any experiments relating to the action of caustic magnesia on fungi; but doubtless that action will be found to be similar.

"Here, then," observes the author, "is a curious and significant fact. Diseased potatoes are deficient in lime-salts, and lime prevents the development of fungi. May not the development of fungi in the vessels of plants be furthered by this deficiency? The circumstances are such as scarcely to leave room for doubt. So far, then, theory and practice agree: lime has been found by experience to be useful in preventing the disease, and it is likely that magnesia will be found to have a similar effect."

**Clay Wasp-Nests.**—All the American species belonging to the genus *Polistes* (wasps) have been considered paper-nest builders; but P. R. Uhler, at the Portland meeting of the American Association, described a species which build nests of clay. This wasp is of dark-brown color, with yellow bands across the abdomen, and with yellow feet. The insect builds a nest of cylindrical shape; and a number of these cylinders were found in the stump of a decayed tree, in Charles County, Md. The central cavity of the stump—which was about five inches in diameter—contained thirty-three of these peculiar structures. They were of yellow clay, generally about half an inch in diameter, and varying from two to five inches in length.

The nest, or more properly the receptacle for the egg and young, is constructed in the following manner: The adult wasp works some wet clay into an oval pellet, and carries it to the place where the nest is



to be made. The pellet is then laid obliquely and pressed down by the fore-feet and head of the insect, so as to cause it to adhere firmly to the surface on which it is building. As it proceeds, it smoothes the inside of the cylinder by working with its jaws and pushing the front of its flat head against the plastic clay. The first section being thus finished to its satisfaction, it flies off to secure small spiders. It seizes a spider with its fore-feet, stings it in just such a way as to paralyze, without destroying its life, and then deposits it in the bottom of the cylinder.

An egg is then laid beside the spider, and the wasp flies off to secure other spiders. This is continued until the cavity, which holds from twelve to fifteen of the smaller kinds, is full. The wasp then covers the open end with a cap of the same material as before, after which it adds other sections to the number of three or four, filling each with spiders and depositing one egg in each. The young larva feeds on these paralyzed spiders, and, as it seems, requires from twelve to fifteen of them to nourish it until it is ready to become a pupa. Unlike some other clay-nest builders, this wasp does not nurse its young, but they are securely sealed up in the sections, and feed themselves. When ready to come forth, the wasp gnaws a round hole in the wall of its cell, and issues forth as a perfect insect.

**The Uses of Baryta.**—Baryta is an alkaline earth of a gray color, not easily fusible, and poisonous. Its various salts are extensively used in the arts, as will be seen from a paper read by Dr. Lewis Feuchtwanger, before the Polytechnic Club, of which we present a synopsis. The sulphate of baryta, 66 per cent. of baryta and 34 of sulphuric acid, is the only baryta-salt that is not poisonous. It is abundant in England, France, Germany, and the United States, where it usually occurs in connection with beds or veins of metallic ores, as gangue, or vein-stone. Sometimes, however, it forms distinct veins, in company with the secondary limestone, and very often in fine crystals, along with calcite and celestine. Connecticut and Missouri have long furnished abundant material for the arts. Next come

Virginia, New York, New Hampshire, Massachusetts, Pennsylvania, Kentucky, and Tennessee. The variety known as "Bologna spar" is an ornamental stone, of a brown color, and concentric rings, originally found in a bed of clay near Bologna. The sulphate of baryta also often occurs associated with lime, and some silica and alum, and is then called calcareobaryte; when associated with strontia it is called baryto-celestine.

*Witherite* is a carbonate of baryta, consisting of 78 per cent. baryta and 22 carbonic acid. It is found, in considerable quantities, in England, Silesia, Hungary, Sicily, and Chili, but not much in the United States. It is largely used in plate-glass manufacture in France, as also in the manufacture of beet-root sugar, and *permanent white*. Latterly, it has come into use for paint, in combination with soluble glass and white oxide of zinc. The metallic base of these salts is barium. It is a white, malleable, and fusible metal, readily oxidizing in air, and decomposing water at common temperature. The pure baryta, oxide of barium, is used for the production of peroxide of hydrogen, which is much recommended as a medicinal reagent, and employed in the arts for bleaching animal tissue, and converting brown into blond hair. The oxide, or caustic baryta, rivals, in caustic properties, potash, soda, and ammonia.

The chloride of barium is got by fusing the sulphate of baryta with chloride of calcium, in a reverberatory furnace, and then extracting with hot water, leaving the sulphate of lime undissolved. Chlorate of baryta, used in pyrotechny, and which burns with a green flame, is prepared by dissolving artificial carbonate of baryta in chloric acid solution. Nitrate of baryta, likewise used in pyrotechny, may be got by dissolving the native carbonate in nitric acid and evaporating the solution, octahedral crystals being deposited. The native sulphate of baryta is used to adulterate white lead, often to the extent of 25 to 50 per cent.

The artificial sulphate, permanent white, is much used in the manufacture of a paper of the purest white, for collars, cards, etc. In copper metallurgical operations, the sulphide of barium has latterly been employed for the purpose of precipitating from an ammoniacal copper solution the copper as a



sulphide. The artificial carbonate of baryta, produced by passing carbonic acid through a sulphide of barium, is much used in Europe in the manufacture of achromatic glass.

**Subterranean Fish.**—For the purpose of supplying water to a new wharf at Point Hueneme, southeast of San Buenaventura, Cal., an artesian well was sunk not five feet from high-water mark. At the depth of 143 feet a strong flow of water was obtained, which spouted 30 feet high. A goose-neck was fitted on the bore so as to reverse the flow. One day while the agent was absent, the men noticed fish in the waste-water. On his return attention was given to the fact, and the well was found to be filled with young trout, thousands of them being thrown out at every jet. These trout were all the same size (about two inches long), and perfectly developed. *They had perfect eyes.* There is no stream nearer than the Santa Clara River, several miles distant. There are no trout in the lower portions of the river. The temperature of the water is the same as that of the wells of this country (64° Fahr.), too warm, of course, for trout to live long in.—*American Journal of Science.*

**New Refrigerating Machine.**—A refrigerating apparatus, invented by Captain Frederick Warren, British Navy, is described as follows: It consists of a small steam-engine, to which is attached a second cylinder for condensing ether-vapor. The cold produced by the expansion of this condensed ether is utilized by being communicated to brine contained in pipes, around which the ether circulates. The brine thus cooled is used in its turn either to freeze water or to cool air, the water being contained in reservoirs immersed in a vessel of cold brine, and the air being conveyed in pipes which wind backward and forward in the brine. The ether employed, being contained entirely in closed apparatus, is scarcely at all wasted, and little more than its first cost need be taken into account.

In the experiments made with the machine, the moisture on the outside of the pipes leading to the refrigerator was rapidly frozen, and the air of the room, after being withdrawn at a temperature of 62°

Fahr., was almost immediately returned to it at 45°. As this process continued, the temperature of the room was rapidly reduced, and might easily have been brought to the freezing-point and so maintained. Captain Warren claims that the temperature of any limited space can be thus kept down to almost any required degree, and he proposes to apply the method to the construction of cold chambers on board ships, to be used for storing fresh provisions, or, in the case of merchant-ships, for the conveyance of perishable freight. He does not, however, think it possible to freeze a whole cargo of meat, so as to resist putrefaction in a long voyage, as from Australia to England. He proposes to cool railway-carriages, to provide cool vases for the conveyance of meat and other provisions in India, to cool the air admitted into hospital wards, and to provide an unlimited supply of pure ice at almost nominal cost.

---

## NOTES.

THE latest application of the sand-blast is for cleaning the fronts of buildings, by removing the soot, dust, and other substances therefrom. The impact of the sand on the surface removes the dirt from all the crevices and indentations, without perceptibly affecting the sharpness of the architectural ornamentation.

IN the course of a lecture on mercury recently delivered at Vienna, the leg-bone of a man was exhibited, whose death had undoubtedly been hastened by mercury. On striking the bone heavily on the table, out fell thousands of little glittering globules, which rolled about on the black surface before the lecturer, collecting here and there into drops. This mercury had been absorbed during life, and proved the death of the absorbent.

IN 1871 the census of Ceylon was taken, it being the first attempt of the kind in that island. When this measure was first talked of, a belief prevailed in the minds of the Cinghalese that it was but a preparation for the levying of a new tax. In many districts the natives said that the object was to discover the number of unmarried youths, with a view to their being deported to Europe, whose male population, they said, had been destroyed by a great war. This led to an unusual number of marriages being celebrated. The population of the islands is 2,500,000. Their religion is looked after by 5,345 Buddhist priests, 1,078 Sivite

priests, 449 Mohammedan priests, 862 devil dancers, 217 Protestant missionaries, and 87 Catholic priests. Over 1,500,000 of the people are Buddhists, nearly 500,000 Sivites, and about 183,000 Catholics, while 35,406 are parceled out between four varieties of Protestantism.

IN the January POPULAR SCIENCE MONTHLY we gave the State Geologist of Minnesota as authority for the statement that iron-ore exists in vast quantities in the neighborhood of Black River Falls in that State. Prof. N. H. Winchell, the State Geologist referred to, has since written us that he never made the statement, and is not aware that iron-ore, in any quantity, is found in that locality. The item and the authority for it were taken from the *Journal of the Society of Arts*, an esteemed contemporary, which had evidently been misled like ourselves.

THE yield of gold in New Zealand up to the end of the year 1872 was 6,718,218 ounces, valued at £25,814,260, of which the north island furnished 734,269 ounces, worth £2,563,307. This gold is obtained by lode-mining in igneous rocks of the Neozoic epoch. The south island furnished 5,983,979 ounces, value £23,250,953, chiefly obtained from the metamorphic rocks by alluvial washing.

IN the competition last October for the \$100,000 prize offered by the State of New York for a satisfactory application of steam-power to canal navigation, one of the competing boats, the Baxter, carrying 200 tons of cargo, and drawing 5 feet 8½ inches water, traveled about 55 miles in a little over 18 hours, consuming only 830 pounds of hard coal. None of the performances, however, were deemed satisfactory by the commissioners, and the prize was again withheld.

A CORRESPONDENT of the London *Times* communicates to that journal some interesting notes on the *Eucalyptus* as a house-plant. He says that he has several of the young trees, grown from seeds, in his house; that they grow remarkably well, are very pretty, and emit a very pleasant odor, much resembling that of the black currant. They retain their green leaves through the winter. The only objection to them as house-plants is that they become too large; but it is easy to have a succession of them by sowing seeds again. There are several varieties of the *Eucalyptus*, three of which—wattle gum, blue gum, and scented gum—the correspondent has growing, and he says that they are very much alike in all respects.

At the recent meeting of Italian men of science at Rome, the *alienist* physicians—that is, those who make a specialty of men-

tal disorders—held sessions of their own, under the presidency of Prof. Girolami. After a long and interesting discussion, protracted through several sessions, they founded a *Societa Freniatrica Italiana*, or Association of Alienists. This body is to assemble every third year, each time in a different city of Italy, the first meeting to take place at Imola next year. Among the subjects for discussion we notice the two following, viz.: "Uniform Classification of Mental Disorders," and "The Founding of Insane Asylums for Criminals."

BENJAMIN DISRAELI, in a late speech at Glasgow, made the significant admission that the revolutions of science within the last fifty years have had "much more effect" in moulding the world than any political causes; and that they "have changed the position and prospects of mankind more than all the conquests, and all the codes, and all the legislators that ever lived!"

BEFORE Bessemer's invention, the yearly production of steel in England was 51,000 tons; it is now 481,000 tons, or nearly ten times as much. The production of Bessemer steel in the United States for the year 1873 is estimated at 140,000 tons.

THE great work of the De Candolles, father and son—namely, the "Prodromus Systematis Naturalis Vegetabilium," which contains a description of every known species of dicotyledonous flowering plant—has been just completed. The publication of the work was commenced in 1824 by the elder De Candolle. To commemorate the completion of the "Prodromus," the Horticultural Society of Belgium has awarded M. de Candolle a special medal.

PROF. ANSTEAD thus estimates the coal-supply of the world: In the British Islands there are 12,800 square miles; in France, 2,000; in Belgium, 520; Spain, 4,000; in Prussia, 12,000; in Bohemia, 1,000; in the United States, 113,000; in British North America, 18,000, making a total of 152,520 square miles, nearly six-sevenths of which is found in America, and over five-sevenths in the United States. This does not include the 250,000 square miles said to exist in the Rocky Mountain district through which the North Pacific Railroad passes.

THE Silber light is simply an improvement in lamps and burners, which secures the most perfect combustion of the lighting materials yet attained. Air-currents are admitted both into the centre and around the circumference of the flame, and by this means the same amount of oil or gas is made to yield a much stronger and steadier light than that afforded by the appliances in common use.





THOMAS HENRY HUXLEY.

THE  
POPULAR SCIENCE  
MONTHLY.

---

APRIL, 1874.

---

THE AGE OF ICE.<sup>1</sup>

TILL within a comparatively recent time, geologists regarded the climate of the prehistoric periods as tropical or warm temperate. Those who first sought to explain the presence of certain scratches upon ledges, by the action of moving ice in continental masses scouring the surface, were met by ridicule and skepticism. The writer has now before him a caricature devised to illustrate the notions of the literary world upon this subject thirty years since in England. The excellent Dr. Buckland appears clad in furs, such as are required in Greenland, with a map of ancient glaciers under his arm, showing markings made on the rocks 33,333 years ago. On one side is represented a bridge with a scratched paving-stone at the entrance, and an inscription like this: "Scratches made day before yesterday by a cart-wheel passing over Waterloo Bridge." It is said that the learned doctor was greatly amused by the sketch, and sent copies of it to all his scientific friends. The one before us bears his autograph.

But within the last three decades numerous observers have carried out the suggestions of the earlier geologists to a very extensive application. Forbes and Agassiz explored the glaciers of Switzerland in order to learn the laws of ice-motion; Lyell, Murchison, Ramsay, and others, have ransacked the fields of Great Britain in search of facts from which to generalize; and, in our country, Hitchcock, Mather, Whittlesey, Newberry, Dana, and a score of younger men, have made the investigation of the drift period a matter of enthusiasm. The existence of an immense era when all of Northern America and Europe was enveloped by enormous thicknesses of solid ice, crunching fragments of rocks beneath its massive tread, and transporting square miles of moraine rubbish upon its back, is now universally accepted. Some have gone so far as to believe that the entire globe was encircled

<sup>1</sup> The Great Ice Age, and its Relation to the Antiquity of Man. By James Geikie, F. R. S. E., F. G. S. 575 pages. D. Appleton & Co.

in these arctic fetters—as illustrated by the Brazilian researches of the lamented Agassiz.

One of the latest and most extensive works relating to the Ice period is given to the world by James Geikie, of the Royal Geological Survey of Scotland. The subject is treated of with special reference to the phenomena exhibited in the north of Europe. He subdivides the Ice age as follows:

1. *Preglacial Period*.—This is seen best in the “Norwich crag,” where remains of the elephant and mastodon are found in peat-beds, and these are indications of approaching cold.

2. *First Cycle of Cold*.—This exhibits intense glacial conditions, with great confluent glaciers; intermediate mild and warm periods; arctic and southern mammalia visit Britain alternately, according as climatal conditions become suited to their needs. This is followed by an arctic climate with the mountains covered by snow and ice, the glaciers ceasing to be confluent. The era terminates with local glaciers. The deposits laid down are chiefly the “till” and “boulder-clay,” with a few stratified sands.

3. *Last Interglacial Period*.—In this Britain is at first insular, with cold climate; next continental, with climate changing from cold to temperate and genial, and again to temperate. In early stages of the continental condition, the arctic mammalia invade Britain. Subsequently these disappear, and are succeeded by the hippopotamus, etc.; afterward submergence ensues, and the islands are again insulated, perhaps before the climate became again suited to arctic mammalia. At the close of this period the land sinks, reaching the depth of 2,000 feet below its present level in Wales. The deposits of this era are cave-accumulations, river-gravels, and high level beaches. The human implements found with the extinct mammalia are of stone, and of the rudest construction.

4. *Last Glacial Period*.—This was a time of floating ice, comparable with the conditions imagined by the earlier writers for the whole drift period. The climate was arctic, icebergs floated over most of the land, enormous blocks of stone got stranded upon the hill-tops, moraines clogged up valleys, and toward the termination of the period local glaciers manifested the final effort of the ice to gain the mastery. Remains of boreal shells and the mammoth occur for the last time in the frozen sands and ancient beaches.

5. *Preglacial Period*.—The land has regained its present level, terraces are formed by immense rivers, arctic forms of life have disappeared, and the era of bronze and iron implements shows what progress man has made in the arts.

*Till*.—Throughout the length and breadth of Scotland occur scattered heaps and ragged sheets of sand, gravel, and coarse *débris*, together with wide-spread deposits of clay largely obscuring the solid ledges. In the Highland and upland districts these deposits seem to be

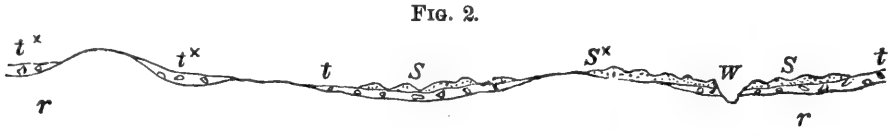

FIG. 1.



GREENLAND GLACIER.—The Ice breaks off in immense Masses.

largely restricted to the valleys, while in the Lowlands they spread in broad sheets, continuous over wide tracts. The very bottom earth is a strong clay or till, much like our hard-pan, which is therefore older than any of the overlying deposits. Their relations are shown in the accompanying figure.



DIAGRAMMATIC SECTION, SHOWING RELATIVE POSITION OF TILL  $tt^x$  AND OVERLYING SAND AND GRAVEL SERIES  $SS^x$ .  $W$ . = RIVER VALLEY.

This till is so tough that engineers would much rather excavate the most obdurate rocks than attempt to remove it from their path. Hard rocks are more or less easily assailable with gunpowder, and the numerous joints and fissures by which they are traversed enable the workmen to wedge them out often in considerable lumps. But till has neither crack nor joint; it will not blast, and to pick it to pieces is a

FIG. 3.

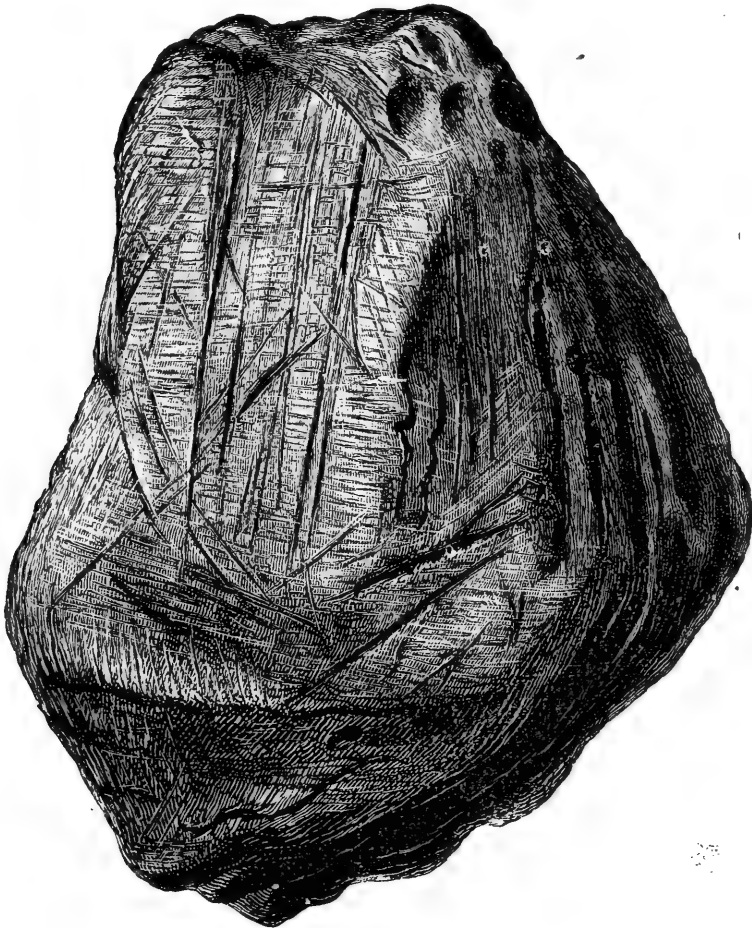

SCRATCHED STONE (Black Shale), FROM THE TILL.

very slow and laborious process. Should streaks of sand penetrate it, water will readily soak through, and large masses will then run or collapse, as soon as an opening is made into it.

The percentage of stones present is variable. They are most common in the hilly districts, while in the lowland region the clay may predominate. Most of them show markings all over. They vary in size from grains to blocks several feet or even yards in diameter. Their shape is peculiar. They are neither round nor oval like the pebbles in river-gravel, or the shingle of the sea-shore; nor are they sharply angular like newly-fallen *débris* at the base of a cliff; but seem to be like the latter in general shape with the sharp corners and edges smoothed away. They are to the geologist what hieroglyphics are to the Egyptologist—the silent but impressive records of an age long passed away.

In narrow valleys the till often accumulates in such amount as to cover the solid floor many yards in depth. In such cases, the surface may be level, and, in the subsequent periods, the streams have made excavations in the mass, leaving the till in the terrace-form. Its unstratified character will be determined by examining the earth along

FIG. 4.

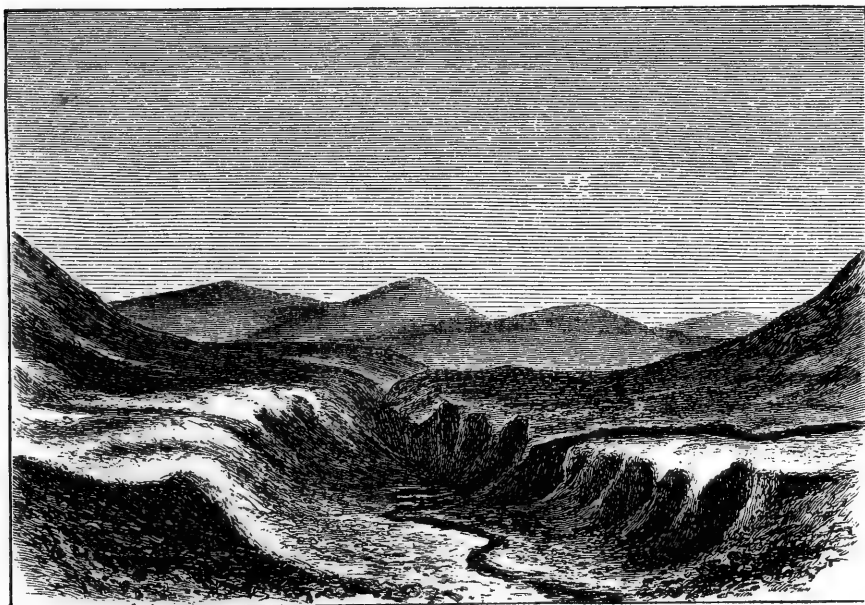

GRESKIN BURN, DUMFRIESSHIRE.—STREAM CUTTING THROUGH TERRACE OF TILL.

the sides of the escarpment, as, superficially, it is difficult to distinguish the material from the terraces of later age.

When the till is removed from the underlying rocks, their upper surface almost invariably shows a smoothed and often highly-polished appearance, and the whole pavement is marked with those peculiar scratches or striæ that form so characteristic a feature of the embedded stones. The extent to which the polishing is carried depends very much upon the nature of the rock. As the best-preserved stones of the boulder-clay consist of close-grained limestone and clay iron-stone, so the same materials in the ledge-condition preserve most perfectly

the fine lines of striation. The soft sandstones and highly-jointed rocks are much less finely marked, and often show a broken and shattered surface.

GREENLAND.—To understand the appearance of Northern Europe in the Ice period, we may consider the features presented by a similar ice-covered country in modern times, and no country will better illustrate this phase of geological condition than Greenland. This island is almost continental in its dimensions, containing not less than 750,000 square miles, and is all a bleak wilderness of ice and snow, save a little strip extending to  $74^{\circ}$  north latitude along the western shore.

The coasts are deeply indented with numerous bays and fiords or firths, which, when traced inland, are almost invariably found to terminate against glaciers. Thick ice frequently appears, too, crowning the exposed sea-cliffs, from the edges of which it droops in thick, tongue-like, and stalactitic projections, until its own weight forces it to break away and topple down the precipices into the sea. The whole interior seems to be buried beneath a great depth of snow and ice, which loads up the valleys and wraps over the hills. The scene opening to view in the interior is desolate in the extreme—nothing but one dead, dreary expanse of white, so far as the eye can reach—no living creature frequents this wilderness—neither bird, beast, nor insect. The silence, deep as death, is broken only when the roaring storm arises to sweep before it the pitiless, blinding snow.

This represents perfectly the state of the northern part of our continent in the Ice age. We have a slight inkling of what it must have been universally, from the heroic messages sent down in the winter from the meteorological observatory stationed upon the summit of Mount Washington.

Some of the Greenland glaciers attain a vast size. Dr. Kane reports the great Humboldt glacier (*see* Fig. 1) as sixty miles wide at its termination. Its seaward face rises abruptly from the level of the crater to a height of 300 feet, but it is not known how deep it may extend under the sea. Another important ice-stream is the Glacier of Eisblink, on the northwest part of the island. It projects seaward so as to form a promontory thirteen miles in length. It comes from an unknown distance in the interior, and plunges deeply into the sea.

Since ice is lighter than water, whenever a glacier enters the sea the dense salt-water tends to buoy it up. The great tenacity of the frozen mass enables it to resist the pressure for a time. By-and-by, however, as the ice reaches deeper water, its cohesion is overcome, and large segments are forced from its terminal part, and floated up from the bed of the sea, to sail away as icebergs. The glacier evidently crops under the water to considerable depths, or, so long as the force of cohesion is able to resist the tendency of the salt-water to press it upward. The annexed diagram will show how the ice pushes down into the sea, carrying morainic materials at its base, which accumu-

late at *m*; *tb* may show the origin of the block *i*, which is now going to sea as a buoy. In many cases the icebergs must carry with them stones frozen on the under side, as well as blocks perched on their backs. Dr. Kane speaks of ice-rafts, floating many miles out to sea—tables 200 feet long covered with large angular blocks and boulders.

FIG. 5.

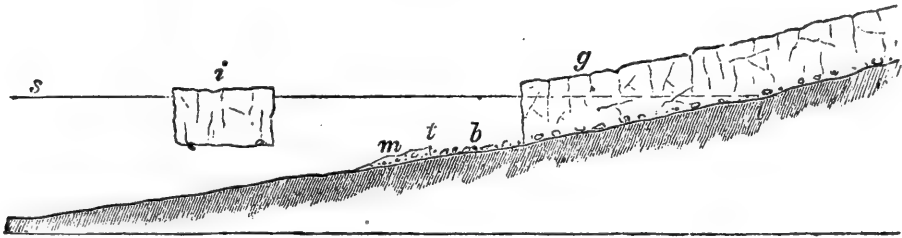

GREENLAND GLACIER SHEDDING AN ICEBERG.

Though Greenland is said to be inhabited only upon the south and west coast, there is a record of an early settlement upon the side toward Iceland, with which there has been no communication for 400 years. The colony was planted about 1000 A. D., which flourished, and maintained intercourse with its mother-country till the beginning of the fifteenth century. Since that time, owing to the setting in of the arctic current, and the consequent gradual increase of ice upon the coast, the colony became inaccessible, and the records of it disappear from history. At various intervals between, 1579, 1751, etc., down to our own time, the intrepid Danes have striven in vain to reopen communication with their lost colony. This emerald coast, with valleys well stocked with reindeer and verdant glades, is now shut in by the pitiless ice-pack, and the fate of its inhabitants ought to excite the interest of the world. It would be very interesting to be informed of the condition of this colony: whether the increasing cold has enlarged the glaciers so as to push the dwellings out to sea, or whether the habitations are still standing; and a population has sprung up who know of the outside world only by tradition.<sup>1</sup>

*Lake-Basins.*—A strong argument for the former existence of glaciers over the northern regions comes from the excavation of basins from the solid rock for the reception of lakes. The country most traversed by the ice agency abounds in these rock-hollows. It is very evident that the glacier is the only agency which can well be called upon to explain these phenomena. Running water excavates only on a descending plane. Sea-water acts upon its level, while the glacier requires only a pressure from behind to enable it to ascend mountains. The upward movement of the ice is shown by the striæ to have been exceedingly common.

The glacier grinds hardest where the steeper slope is exchanged for a less inclination of its rocky bed; the tendency of this action is to

<sup>1</sup> *Geological Magazine*, vol. x., p. 541.



FIG. 6.

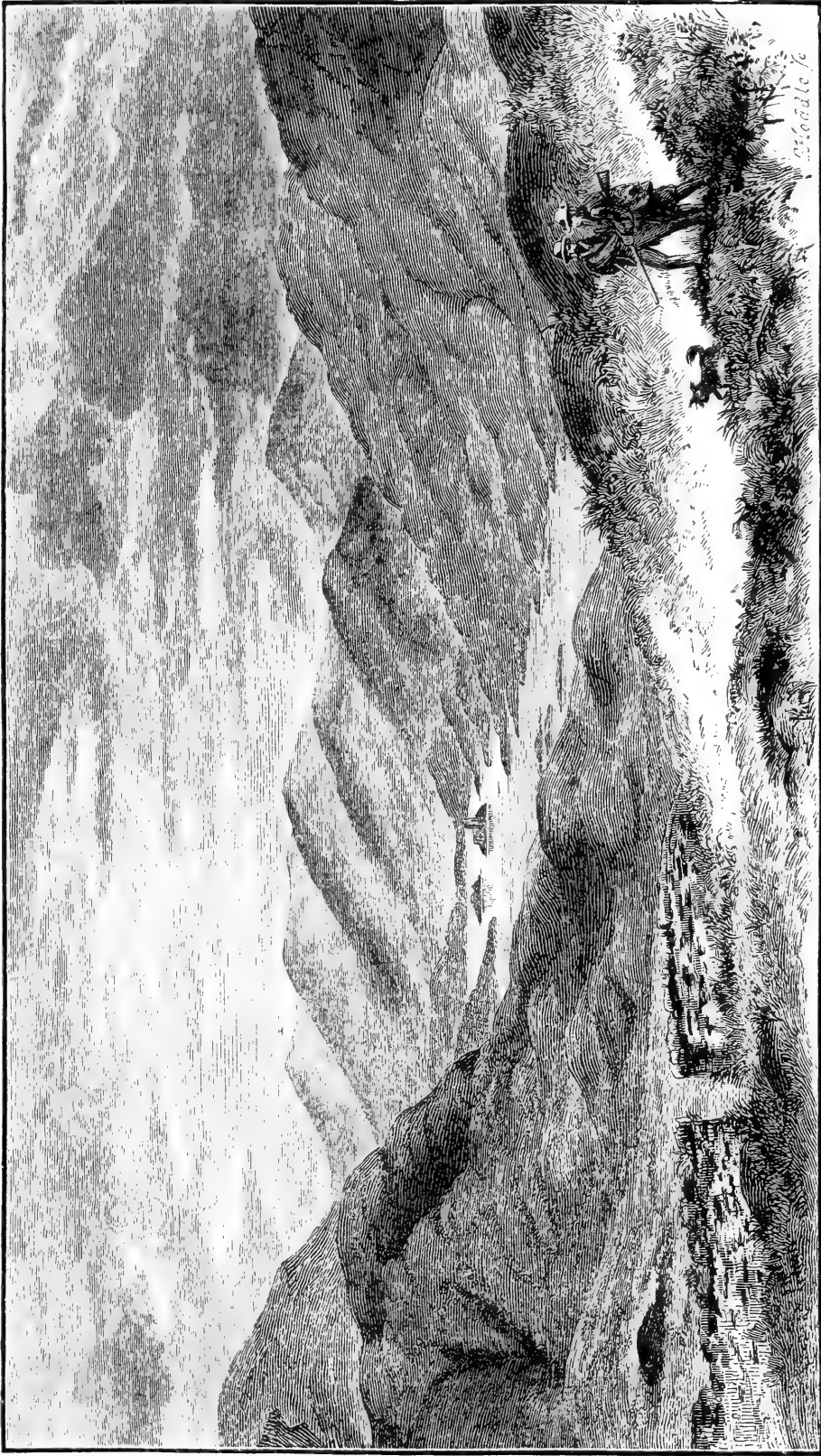

Loch Doon (upper reach).—A Rock Basin, supposed to be excavated by Glacial Action.



increase the length of the greater in elevation, or, in other words, to scoop out material from the ledges, in a part of the course, and, after the strength of the graver has exhausted itself, the ice will move up a slope with little energy. This process will excavate hollows that may be filled with water in later times. Such are the basins of the great American lakes. The dimensions of the lakes are areally proportionate to the extent of the drainage-system in which they occur.

FIG. 7.

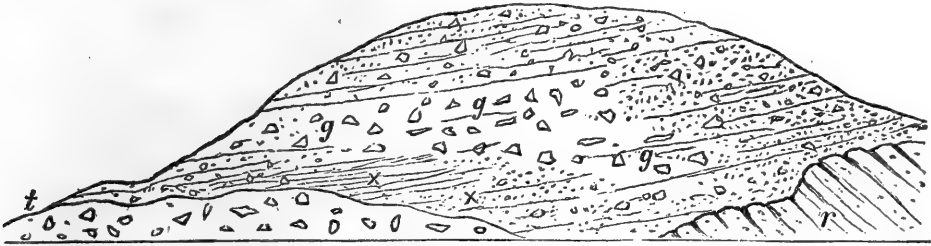

TILL OVERLAID WITH BOWLDER-CLAY, RIVER STINCHAR. *r*, Rock; *t*, Till; *g*, Boulder-clay. *x*, Fine Gravel, etc.

*Boulder-Clay.*—There is a distinction to be drawn, in Scotland, between the “till” and “boulder-clay.” The two deposits pass into each other on the Highlands, and Mr. Geikie proposes to limit the latter to the maritime districts. The boulders of the clay are more rough and angular than those found in the till. The annexed section shows where the two deposits come into juxtaposition. This clay has not been met with more than 260 feet in vertical height above the sea. It contains an abundance of shells of *Arctic mollusca*. Possibly it is the “Champlain clay” of America.

*Antarctic Ice-Sheet.*—From a study of the ice of the Antarctic Continent, it is possible to understand the origin of icebergs, and the transportation of large blocks of stone, in “erratics.” The water is deep, and thus buoys, of enormous size, may float northerly for hundreds of miles.

Sir J. C. Ross attained the highest southern latitude on record, but found all his attempts to penetrate farther frustrated by a precipitous wall of ice, frequently 180 feet in height. For 450 miles he found this cliff unbroken by a single inlet. While coasting along this barrier his ships were often in danger from stupendous icebergs and thick pack-ice, extending in masses too compact to be penetrated. At one point the ice descended sufficiently low to allow Ross to look down upon it from the mast-head. The upper surface appeared to be a smooth plain, shining like frosted silver, and stretching away as far as eye could reach into the illimitable distance. In principle, the sheet is the same with that figured in the north, but more extensive. Like this must have been some portions of the glacial sheet in Scotland, when the land was mantled in ice-covering, filling up the intervening straits and channels of the sea, and terminating far out in the Atlantic Ocean, in a flat-topped vertical cliff of blue ice.

FIG. 8.

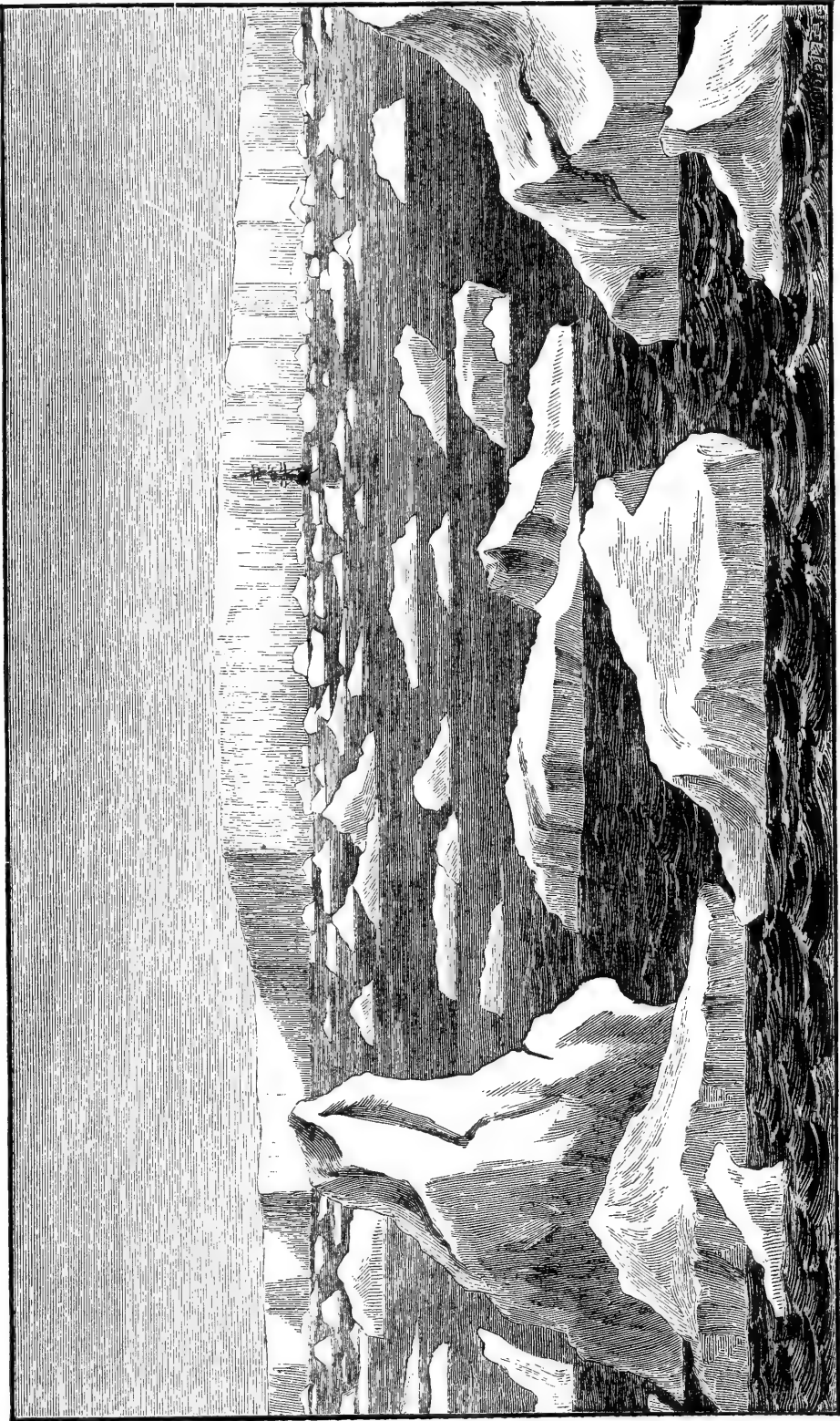

ANTARCTIC ICE-SHEET.—A precipitous Wall of Ice, 180 feet high, along the Base of which Sir J. C. Ross sailed 450 Miles.

*Erratics.*—These are of all shapes and sizes, occasionally reaching colossal proportions, and containing many hundred feet. Some are rounded, others are angular, and not a few exhibit marks of scarification. They may rest on base-rock, and, if carefully poised, may be made to oscillate by the form of the land, or these large blocks may appear on the till, angular *débris*, and hills of gravel. As a general rule, they prove to have been carried from higher to lower levels in Scotland, though many exceptions are recorded. There is one at the height of 1,020 feet on the Pentland Hills, which may have traveled westerly as much as eighty miles. It probably passed from one mountain across a wide valley before attaining its final resting-place. This is not so striking as the blocks lying nearly over the recently-completed Hoosic Tunnel, in Western Massachusetts, one of which weighs 510 tons, and has been transported from Oak Hill across a valley 1,300 feet deep. It has hundreds of lusty comrades, scattered in a southeasterly course for thirty miles.

Sometimes a large block is revealed by the washing away of the till around it. Those on the surface of gravel may have been carried by floating ice. To such blocks it is not easy to assign limits of the distance traveled, since icebergs may float for thousands of miles without melting.

ORIGIN OF THE COLD CLIMATE.—The question of the cause of the glacial cold has been discussed warmly for a long time. The opinion seems to be gaining ground that purely geological causes are not sufficient to account for the magnitude of the glacial distribution. The precession of the equinoxes, changing the times of the seasons, and the eccentricity of the earth's path around the sun, lengthening the winters and increasing precipitation of moisture, when combined with certain changes in the courses of ocean-currents, and some elevation of land in the north, may have together been instrumental in bringing around a period of intense cold. If it be possible to use the orbital changes as a guide to a chronological date for this term of cold, we can say it began about 240,000 years since, and continued for 160,000 years, terminating 80,000 years before A. D. 1260. The cold would have culminated about 30,000 years after its beginning.

Granting such figures, we can understand that the glacial must have been the dark age in the earth's history—a terrible blight upon the flourishing faunas and floras existing in tertiary times in northern latitudes. The presence of warm temperate plants in Greenland has always excited interest, even to the proposal of very wild theories to account for the genial climate there of preglacial days. It may be that the American *Sequoia* traveled across the bridge anciently connecting Greenland with Iceland and Scotland, and that the renowned cedars of Lebanon are the cousins of their famed relations in California; but the connection has been severed by the ruthless ice-flow, and is not likely to be reëstablished, unless our sun shall carry his sys-

FIG. 9.

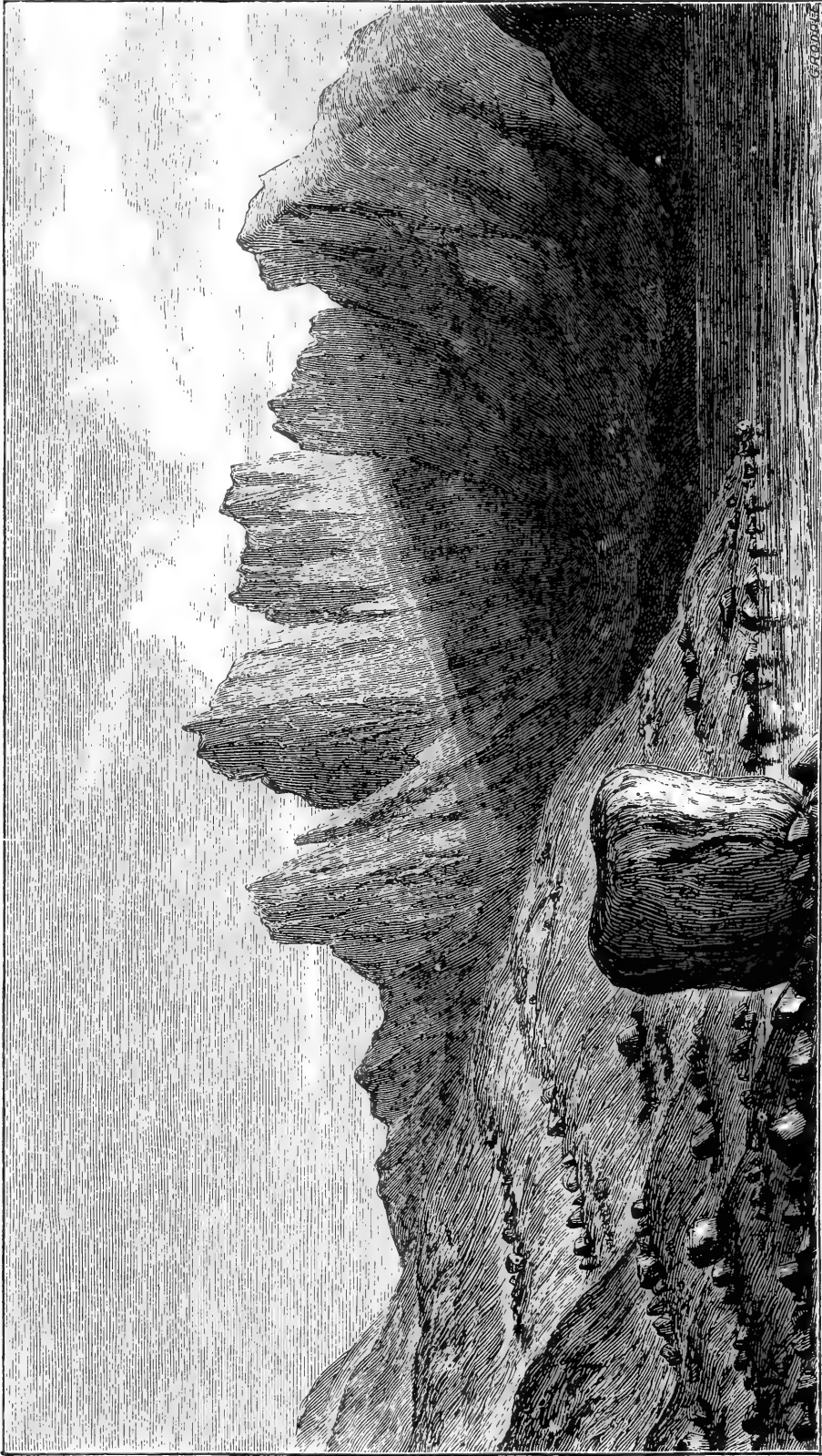

ERRATIC BLOCKS OR BOWLERS RESTING ON GLACIATED ROCKS IN FOREGROUND, COOLIN MOUNTAINS, SKYE.



tem of planets through a much warmer region than the space now encircling us.

*Centres of Dispersion.*—All existing glaciers flow from higher to lower levels as a rule—the only exception being that already stated, when the ice may be forced up-hill for a short distance. This may be well exemplified in the Alpine glaciers of the present day. These streams of ice all flow from the summits and axes of particular mountains along the valleys, and spread over the neighboring plains. The action is radial—proceeding from a central point or line outward.

FIG. 10.



ALPINE GLACIER.—(H. M. Skae.)

The geologists have concluded that most of the ancient ice-movements in Northern Europe have been from centres of dispersion, like those in Switzerland. Examples are numerous. One of the most interesting is exhibited in Switzerland. The traveler finds there two prominent centres of glacial radiation—the Bernese and the Mont Blanc regions. Glaciers now flow westerly into the great valley of Switzerland and toward the Rhone from the former, and in the latter group the streams discharge upon the Italian plains on the south, and toward the vale of Chamouni on the north. A careful study of the vale of Chamouni shows that ice once filled it to the brim, for the embossed rocks carry striæ even to the height of 5,000 feet.

Search for the sources of bowlders proves that large blocks on the southern flanks of the Jura Mountains must have been derived from Mont Blanc, sixty or eighty miles distant. Instead of passing down the Arne at Chamouni, the blocks proceeded northerly toward the Rhone, and thus across the great valley of Switzerland to the Jura. The magnitude of this ancient action equals much of the wonderful glacial phenomena of other districts in Europe, though hardly equal to what may be seen on this continent. But, being satisfied of the former enormous extension of the Alpine glaciers from examination of the striations and the dispersion of blocks, it is easy to generalize and refer similar phenomena in other countries, whose glaciers are extinct, to the same mighty cause.

In Scotland there may have been a centre of dispersion for glaciers from Ben Nevis, another in the south part of the province. In England, one in the Cumberland region; in Wales, one from Mount Snowdon. It is easy to discover the evidence of radial dispersion.

A combination of the glacial and iceberg agencies may be discerned in a map in Mr. Geikie's work, showing the courses of the striæ marked upon the rocks of Scandinavia. They diverge from the central water-shed between Norway and Sweden—part pushing toward Iceland and Scotland, and part directed toward Lapland and the Baltic Sea. The distribution of the bowlders corresponds with these marks. Furthermore, these ice-masses seem to have come in contact with the water of the Baltic, and part have floated over Germany till high land obstructed farther movement, and a part may have been caught by the outflowing Baltic current, carried over the North Sea to the south part of England, and perhaps Iceland. At least, bowlders of Scandinavian origin are common in these regions, and have probably migrated in the way described. On the east shore of Scotland they are plenty; but, between these and those south of the Thames, none have been found, which fact has given rise to the theory of dispersion by means of icebergs through the Baltic.

In years past the prominent topic of discussion in scientific associations has been the character of the ice-movements in the Glacier period. One school has stoutly defended icebergs as the active agent, the other has vigorously insisted upon land glaciation. The example before us seems to require both these agents to account for all the phenomena of this period. Both classes seem to be right, though neither can explain all the facts. Nature's domain is so vast that human intellects do not seem to be capable of grasping the whole truth at once. We are like the mariners who seek to penetrate to the north-pole. They have penetrated a little way beyond Spitzbergen—they have gone nearer the goal through the straits west of Greenland, and have made great exertions in some other quarters. Each party has its theory of the character of the unknown region, as derived from a partial survey. By-and-by the whole of this area will be known, and it



FIG. 11.

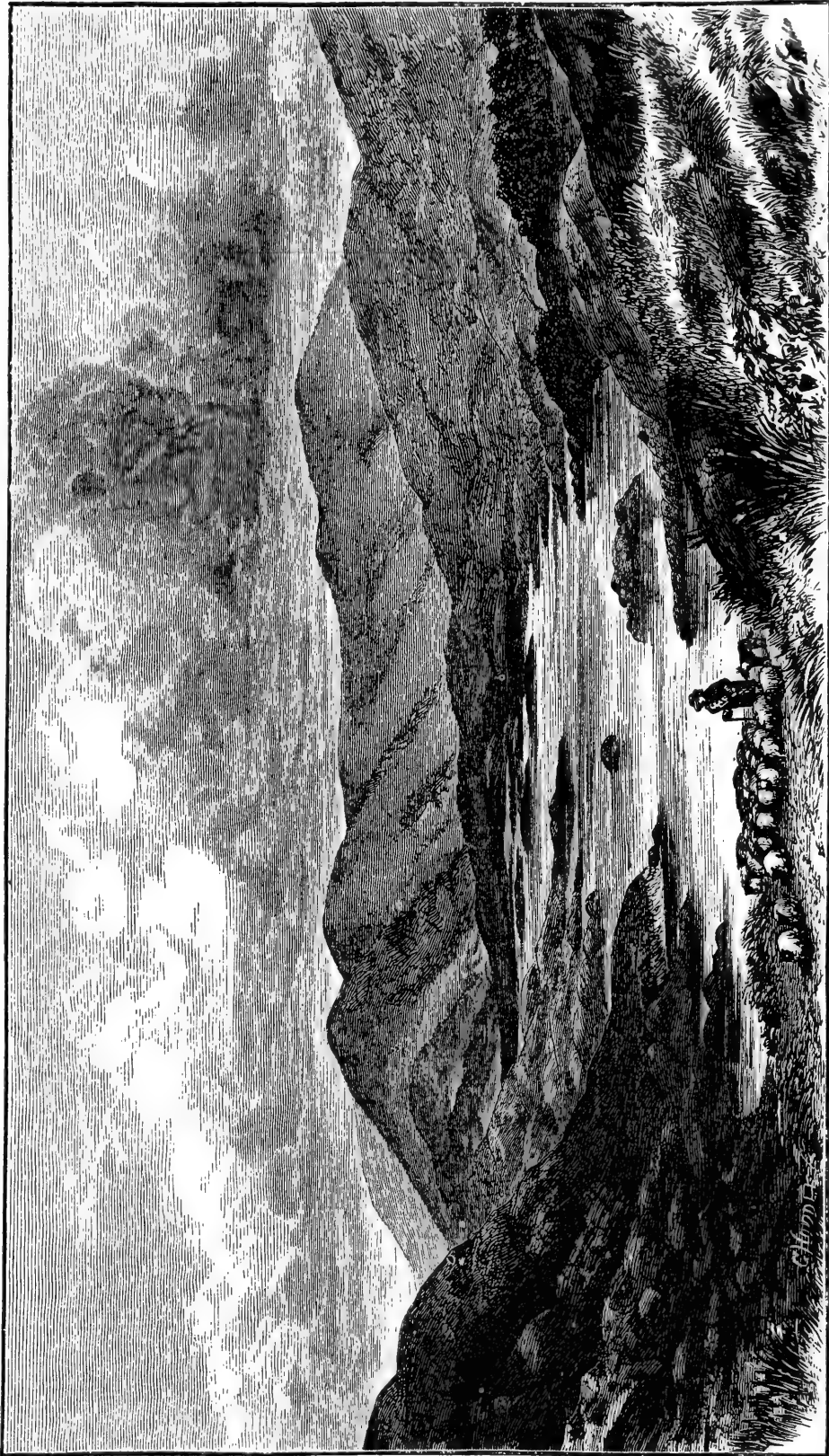

Loch Doon (lower reach), illustrating Rounded Outline of Hills and Slopes produced by Action of Ice. The effect is most marked in certain directions which indicate the course of the ice-masses.

will then appear that each theory had its element of truth. In like manner we are endeavoring to attain to the proper conception of the condition of the earth in the Age of Ice. The whole truth has not yet been discovered. When fully revealed, it will appear far more magnificent and glorious than has now been surmised.



## THE PATHOLOGY OF THE PASSIONS.

BY FERNAND PAPILLON.

TRANSLATED FROM THE FRENCH, BY J. FITZGERALD, A. M.

### III.

IN the former part of this essay we considered the general physiology of the passions: their pathology is no less interesting, and to that we now ask attention. When we reflect that the nervous system of the animal life and the system of the great sympathetic govern all the vital operations, and that the regularity of these latter is absolutely dependent on the orderly performance of their functions by the centres wherein are found the prime springs and the fundamental activities of the animal economy, we conceive at once how countless diseases may arise out of disturbances produced by an abuse or an excess of the passions. Physicians have in all ages reckoned the passions among the predisposing, determining, or aggravating causes of the majority of diseases—especially chronic diseases; for it is a peculiarity of the nerve-substance that it is impaired, and that it spreads abroad the consequences of its impairment, only little by little, and by imperceptible degrees. The work of the passions might be compared to the operations by which an army approaches a beleaguered city: they set about overmastering health and life circumspectly and slowly, but their advance is always sure. A few observations concerning the psychological and physiological disturbances produced by the passions of the moral order, which are the most disastrous in their effects, viz., love, melancholy, hate, anger, etc., will give some idea of the material working of these poisons of the soul.

We may regard love as a neurosis of the organs of memory and imagination, in so far as these two faculties are related to the object of love. The memory in particular seems here to acquire an intensity that is truly extraordinary. In illustration of this point, Alibert states a fact which he observed at Fahlun. As some laborers were one day at work making a connection between two shafts in a mine, they found the remains of a young man in a complete state of preservation, and impregnated with bituminous substances. The man's features were not recognized by any of the workmen. Nothing further was known

than that the accident by which he had been buried alive had occurred upward of fifty years before. The people had ceased to make inquiries as to the identity of the body, when a decrepit old woman came up supported on crutches. She approached the mummified corpse, and in it recognized the body of the man to whom she had been betrothed more than fifty years previously. She threw herself upon the rigid corpse—which was like a bronze statue—wept over it, and manifested intense joy at seeing again the object of her early affection.

As for the imagination, it transcends all bounds, and loses all character of exactitude. The will is no longer mistress of the vital acts. Says Romeo at the tomb of Juliet :

“Here, here will I remain  
With worms that are thy chambermaids.  
Oh, my love! my wife!  
Death, that hath sucked the honey of thy breath,  
Hath had no power yet upon thy beauty ;  
    . . . . beauty’s ensign yet  
Is crimson in thy lips and in thy cheeks,  
And Death’s pale flag is not advanced there.”

“I am drawn toward you,” writes Mdlle. de Lespinasse to M. de Guibert, “by an attraction—by a feeling which I abhor, but which has all the power of malediction and fatality.” The English poet Keats, when dying of consumption, writes thus to a friend: “I am in that state wherein a woman—as woman—has no more power over me than a stock or a stone, and yet the thought of leaving N. is something horrible to me. I am ever seeing her form, which is ever disappearing.” This latter fact pertains to the history of hallucinations, and this in turn borders on the history of ecstasies, which are so frequent in religious life; so true is it that love, even mystical and divine, if not confined within the bounds of reason, turns to a kind of mania, which, as we shall see, is full of danger for the general functions of the mind.

Thought draws the sketch of life, but passion adds the coloring of the picture. When this passion is a happy one, the coloring is brilliant and cheerful, and then life is a bright vernal season. But oftener the passion is a painful one, and the color given by it to life is darksome. Melancholy is one of those passions which throw a gloom over a man’s life. There is one form of melancholy which is plainly a variety of dementia, and which often comes under the notice of the physician. It is characterized by an incurable sadness, an irresistible love of solitude, absolute inaction, and a belief in a host of imaginary evils that are ever haunting the patient. “My body is a burning fire,” wrote a melancholic subject to his medical man; “my nerves are glowing coals, my blood is boiling oil. Sleep is impossible. I endure martyrdom.”—“I am bereft of mind and sensibility,” writes another; “my senses are gone—I can neither see nor hear any thing ;

I have no ideas—I feel neither pain nor pleasure; all acts, all sensations, are alike to me; I am an automaton, incapable of thinking, or feeling, or recollecting—of will and of motion.” This form of melancholia is a disease, and not a passion. It is a species of dementia akin to those strange aberrations which go by the name of lycanthropy, lypemania, etc.

The true passional melancholy is that reflex, profound, painful feeling of the imperfections of our nature, and of the nothingness of human life, which seizes on certain minds, torturing them, disheartening them, and making their life one long sigh. This feeling is expressed by the gentle poet Virgil, when he says, “Sunt lacrimæ rerum” (everywhere tears). This is the gloomy thought that haunts the mind of Hamlet, the hallucinatory despair of Pascal, the sadness which broods over Oberman and René, the bitter, heart-rending cry of Childe Harold, the grand desolation of Manfred, the inquietude and the agony represented by Albert Dürer’s graver and by Feti’s pencil. Melancholy so defined has a place in the depths of the heart of every man that philosophically contemplates Destiny, nor need we seek elsewhere an explanation of the sombre humor which distinguishes men of this kind, and which is witnessed to by those books wherein they convey to us the history of their souls’ troubles. If such a humor as this had its source in the common ills of life—in its sufferings, its miseries, and its deceptions—we might understand it perhaps in the case of such men as Swift, Rousseau, Shelley, and Leopardi; but, when we meet with it in such favored geniuses as Byron, Goethe, Lamartine, and Alfred de Vigny, we are forced to acknowledge that, in men of the higher stamp, its cause must be the pain they feel on seeing that they cannot slake their ideal thirst.<sup>1</sup> \* Such is the melancholy which we may call the *philosophic*.

Besides this, there is another form of melancholy which proceeds from better-defined causes, i. e., from the common griefs and vexations of life. Reverses of fortune, balked ambitions, and disappointments in love, are usually the causes of this kind of sadness, which, being far more active than purely philosophic sadness, often gives rise to organic disorders of the most serious kind. Albert Dürer succumbed to the vexations caused him by his wife. Kepler died the victim of the afflictions heaped upon him by Fate. Disappointment in love is one of the most frequent causes of melancholy. This it is which harassed and tortured Mdlle. de Lespinasse—which troubled and worried the chaste soul of Pamela: it was the death of the beautiful Genoese, Tommasina Spinola, when she heard of Louis XII.’s illness, and of Lady Caroline Lamb, when she went home after the fu-

<sup>1</sup> “What from this barren being do we reap?

Our senses narrow and our reason frail,

Life short, and truth a gem which loves the deep.”

—“Childe Harold,” iv., 93.

neral of Byron. These two women had lived years and years, the one preserving in the depths of her heart the calm despair of an impossible love, the other the bitter recollection of a love that was spurned; but neither of them could outlive the affliction of seeing the object of her affection taken away by death. There are some cases in which the resistance is not of so long duration, and where the ravages of passion are such that the organism becomes dislocated with fearful rapidity. Indeed, it is no rare thing for a physician to be summoned to a patient who is wasting away with sadness and dejection. No organic cause can be discovered to account for the malady; the usual remedies are of no avail; the patient does not mend, and usually keeps the secret of his griefs to himself. In such cases the physician should always strive to discover whether there is any passion of the soul which produces this disorder of the functions, and makes his remedies of no effect. Usually such a passion exists. Thus it was that the physician Erasistratus discovered that Antiochus loved his step-mother, Stratonice. Boccaccio likewise tells of a physician who by chance detected the true cause, previously unknown, of the complaint with which a certain young man was suffering; whenever a young female cousin of the patient entered his room, his pulse beat quicker. It often happens that the melancholic becomes incapable of bearing his afflictions, or of waiting for death to relieve him. This is the origin of suicide. The history of medicine and literature is full of narratives, real or fictitious, of suicide determined by an unfortunate passion. While we admire what is touching and dramatic in such narratives, we cannot fail to see that suicide is *in se* a fact of the morbid kind. Its cause is a total aberration of the instinct of self-preservation; and, as the latter has its seat in a certain part of the brain, we are authorized in locating the cause of suicide in a cerebral disorganization, brought about more or less rapidly by certain more general changes in the economy.

Similar changes are produced sooner or later under the influence of resentment, hate, and anger. Resentment is a secret passion which draws its plans in silence. Hate is taciturn, or finds utterance only in imprecations. Anger has its crises. Whereas resentment is disquieting, hate painful, and anger distressing, revenge is a kind of pleasure. It has been compared to the feel of silk, to indicate at once its imperious nature and our gratification in appeasing it. When anger and the desire of revenge distend the veins, flush the face, stiffen the arms, brighten the eyes,<sup>1</sup> bewilder the mind, and lead it to the commission often of criminal acts, the soul feels a sort of delight, but it is of short duration; and the momentary excitement is followed by a pro-

<sup>1</sup> In his admirable studies on the "Expression of the Emotions," Mr. Darwin notes a characteristic expression of fear, rage, and anger, not found in man, though it appears in all animals—viz., the erection of the hair and feathers. This phenomenon, which is analogous to that of *goose-skin* in man, is produced not only by passional influences, but

found depression whose effects, if oftentimes repeated, differ not from those of concentrated resentment or pent-up hate. The man who is given to outbursts of anger is sure to experience a rapid change of the organs, in case he does not die in a fit of rage.

Death under such circumstances is of frequent occurrence. Sylla, Valentinian, Nerva, Wenceslas, and Isabeau of Bavaria, all died in consequence of an access of passion. The medical annals of our own time recount many instances of fatal effects following the violent brain-disturbance caused by anger. The symptoms usually are pulmonary and cerebral congestions. Still such fatal accidents as these are exceptional: as a rule, the passions of hate and anger deteriorate the constitution by slow degrees, but surely.

How, then, do we explain those morbid phenomena which have their origin in misplaced affection, in disappointed ambition, in hatred, or in anger, and which culminate either in serious chronic maladies, or in death or suicide? They all seem to start from an impairment of the cerebro-spinal centres. The continual excitation of these by ever-present emotions determines a paralysis of the central nerve-substance, and thus affects its connections with the nerves extending out to the various organs. These nerves next degenerate by degrees, and soon the great functions are compromised. The heart and the lungs cease to act with their normal rhythm, the circulation grows irregular and languishing. Appetite disappears, the amount of carbonic acid exhaled decreases, and the hair grows white, owing to the interruption of the pigmentary secretion. This general disturbance in nutrition and secretion is attended with a fall of the body's temperature and anæmia. The flesh dries up and the organism becomes less and less capable of resisting morbid influences. At the same time, in consequence of the reaction of all these disturbances on the brain, the psychic faculties become dull or perverted, and the patient falls into a decline more or less complicated and aggravated by grave symptoms. Under these conditions he dies or makes away with himself.

Two organs, the stomach and the liver, are often affected in a peculiar and characteristic way in the course of this pathological evolution. The modifications produced in the innervation, under the influence of cephalic excitement, cause a disturbance of the blood-circulation in the liver. This disturbance is of such a nature that the bile, now secreted in larger quantity, is resorbed into the blood instead of passing into the biliary vesicle. Then appears what we call jaundice or icterus. The skin becomes pale, then yellow, owing to the

also by cold. Darwin explains this *horripilation*—as it is called—by the action of the nervous system on certain minute involuntary muscles called *arrectores pili*, recently discovered by Kölliker, in connection with the capsules at the base of the separate hairs and feathers. The excitation of these little muscles, which are very numerous over the entire body, determines, by reflex contraction, the erection of which we speak, and affords one of the most characteristic signs of fright, rage, and anger, in animals.



presence in the blood of the coloring matter of the bile. This change in the liver is usually developed slowly: sometimes, however, jaundice makes its appearance suddenly. Villeneuve mentions the case of two youths who brought a discussion to an end by grasping their swords; suddenly one of them turned yellow, and the other, alarmed at this transformation, dropped his weapon. The same author speaks of a priest who became icterical (jaundiced) on seeing a mad dog jump at him. Whatever may be said of these cases, we must reckon painful affections of the soul among the efficient causes of chronic diseases of the liver.

The digestion, says the author of a work published some years ago, is completely subjected to the influence of the moral and intellectual state. When the brain is wearied by the passions, appetite and digestion are almost gone. Whatever causes grief or fright affects the stomach more or less. In times of epidemic, or of civil war, and in all social conjunctures when any extraordinary peril threatens the masses, dyspepsia becomes more frequent, and assumes a more serious aspect. This affection commonly prevails amid the various symptoms of depression and decline produced by moral suffering. The direct pathological consequences of disordered nutrition, whose chief symptom is dyspepsia, are of the most serious nature, and there is no doubt that among them we must reckon cancer. Hence it is that Antoine Dubois located the cause of cancer in the brain.

#### IV.

As a vibrating chord determines vibration in a neighboring chord, so a passion produces in those who are the witnesses of it a passion or a tendency to a passion of the same kind. The infant by a smile responds instinctively to its mother's smile, and it is difficult to contemplate attentively the portrait of a smiling person, especially if we observe that the face wears a smile, without our own faces assuming a like expression. "We cannot," says Leon Dumont, "reflect on any mode of expression, but our countenances will have a certain tendency to conform itself to it." *A fortiori* it will so conform itself when, instead of merely reflecting on the expression, we see it. Yawning, hiccoughing, and sighing, are as contagious as laughter.

All passions, whether good or bad, are contagious. Esquirol seems to have been the first to discern and characterize moral contagion, which he defines to be that property of our passions whereby they excite like passions in others who are more or less predisposed to them. The contagion of good example is manifest, and it is certain that the worship of the saints is one of the wisest and most powerful instrumentalities devised by the Catholic religion. Unfortunately, depraved passions too have their imitators, and in this case the imitation is so prompt, so thorough, and in some sort so automatic, as often to appear irresistible. An able psychological physician, M. Prosper

Despine, who has bestowed profound study on this subject, shows, from a very large number of instances, that when a crime surrounded with dramatic circumstances is published abroad, and made matter of general comment, a certain number of similar crimes will be committed soon afterward. Minds that are not fortified, by a strict morality and a good education, against the allurements of such examples, and whose slumbering passions only await the occasion that will stir them up, are spurred on and decided to act by the bustle and the parade made about the hero of a criminal trial. M. Despine's statistics on this painful subject are exceedingly curious and conclusive. Now it is some peculiar form of murder, again a new process of poisoning, anon, some original way of disposing of a corpse, that gives occasion to grim plagiarisms with all the circumstances identical. In a word, all criminal acts proceeding from hate, revenge, and cupidity, always summon forth in certain individuals a spirit of emulation. Hence it were advisable absolutely to forbid the publication, in popular prints, of criminal trials whether real or imaginary, and to interdict the performance of plays wherein wickedness and crime are portrayed for the gratification of the spectator's morbid curiosity. M. Despine's suggestion with regard to this matter will be approved by physicians and hygienists, who are all agreed that writings and plays of a certain class are to be reckoned among the causes which conduct so many wretches to the galleys, the morgue, and the mad-house. When we disseminate examples of outrage and disorder, we must not be surprised if we find a harvest of crime and insanity. Let us then heartily second the suggestion we speak of, and which M. Bouchut authoritatively formulates when he says that, instead of feasting the public with recitals and plays so dangerous to the common weal, we should rather found a moral pest-house to which should be committed, so soon as they make their appearance, those rascalities whose contagiousness is now beyond question.

Besides the contagion of those passions which end in crime, there is also the contagion of those passionate states which terminate in suicide. Epidemics of suicide are frequent in history. The instance of the young women of Miletus, as told by Plutarch, is familiar. One of them hung herself, and immediately several of her companions made away with themselves in the same manner. To stay the progress of this redoubtable frenzy, the order was given to expose the naked bodies of the suicides in the market-place of the city. An ancient historian of Marseilles records an epidemic of suicide which raged among the young women of that place. In 1793 the city of Versailles alone offered the spectacle of 1,300 voluntary deaths. In the beginning of the present century a suicidal epidemic destroyed large numbers of people in England, France, and Germany, the victims being young persons who had conceived a disgust for life, from the reading of melancholy romances, coupled with precocious over-in-

dulgence in pleasures. A still stranger epidemic is that of infanticide, which prevailed in Paris at the beginning of this century, after the newspapers had published the history of the Cornier case. Madame Cornier, under the influence of infanticidal monomania, had murdered her child under circumstances of such a kind as to make an impression on a certain number of mothers, so that, though excellent women and sincerely attached to their children, they were seized with a desire to get rid of them. They did not yield to the temptation, but the circumstance of their being attacked with such a mania excited much surprise among medical men.

It will not be uninteresting, if to these curious phenomena we append the facts of nervous contagion to which M. Bouchut called the attention of physicians some years ago. It had long been known, especially since the time of the famous *convulsionnaires* of the St.-Médard Cemetery, that some neuropathic states are multiplied by instinctive imitation; but M. Bouchut shows that facts of this kind are far more common than has been supposed, and the work wherein he describes them adds a new and a dramatic chapter to the strange history of nervous aberrations. One of the first cases given by M. Bouchut is as follows—it was observed at Paris in 1848, in a shop where 400 work-women were employed: One day one of these work-women turned pale, lost consciousness, and fell to the floor, her limbs convulsed, and her jaws set. Within the space of two hours 30 of the women were seized in the same way. On the fourth day 115 were affected, the symptoms in all cases being the same, viz., suffocation, prickling sensation in the limbs, vertigo, dread of sudden death, followed by loss of consciousness in the convulsions. A similar epidemic was observed in 1861 among the young girls of the parish of Montmartre, who were preparing for the first communion. On the morning of the first day of the *retraite*—or preparatory season of religious seclusion—while at church, three of them became unconscious, and were seized with general convulsions. The following day the same symptoms appeared in three other girls. Still others were attacked on the third day. On the fourth, the communion-day, 32 were seized in the same way. On the fifth, confirmation-day, as the archbishop approached, 15 girls were seized with convulsions, uttered a shriek, and fell to the floor unconscious, when the prelate was about to confirm them. Thus, in the space of 75 days, 40 girls out of 150 manifested identical nervous disorders.

The various hallucinational, ecstatic, and spasmodic states, transmitted and multiplied by example, play an important rôle in mediæval history, particularly among the religious orders. There is the closest analogy between the accounts handed down to us by the writers of those times and the observations of physicians published in our own day. As concerns the question of treatment, we possess hardly any save moral remedies; and the success attending the employment of

these shows well the purely nervous character of these singular affections. We read of Boerhaave staying an epidemic of hysterical convulsions in a boarding-school by threatening to burn, with a red-hot iron, any of the girls who should be attacked. Practitioners in our own time adopt analogous processes and artifices to conquer those passions which degenerate into morbid states. They strive to inspire the patient with a passion different from that which possesses him, and to fix his attention on subjects disconnected with those which occupy his mind.

This style of physic—this moral therapy—requires infinitely more tact and discernment than the application of the usual remedies of the pharmacopœia. Nor is it in our medical schools that young men, who intend to practise the healing-art, can learn to diagnose and to treat those maladies wherein the soul wrecks the body. This is a vocation which requires profound personal study and observation, and wherein the student would do well to draw on a source too much overlooked in our times, viz., those old authors who treat questions of this kind. The young physician will find equal profit and delight in studying those profound connoisseurs of the human mind, La Chambre, Stahl, Pinel, Hoffmann, Bichat, Tissot, Richerand, Alibert, Georget. From them the student will not only learn how to judge wisely of the passions of others and of the best means of treating them, but will also get sage counsels for the government of his own. There he will see that there is nowhere perfect health, save when the passions are well regulated, harmonized, and equipoised, and that moral temperance is as indispensable to a calm and tranquil life as physiological temperance. He will see that, without going the lengths of stoicism—in which there is more pride than wisdom, more ostentation than virtue—the noblest and the most desirable state for the mind and body alike is equidistant from all extreme passions, i. e., situated in the golden mean. And this conviction that regular living and moderation in material as in emotional life are the secret, not, indeed, of happiness—which is nowhere in this world—but of serenity and security, he will strive to spread abroad as being the most useful precept of the medical art. If it is your desire that your circulatory, respiratory, and digestive functions, should be discharged properly, normally, if you want your appetite to be good, your sleep sound, your humor equable, avoid all emotions that are over-strong, all pleasures that are too intense, and meet the inevitable sorrows and the cruel agonies of life with a resigned and firm soul. Ever have some occupation to employ and divert your mind, and to make it proof against the temptations of want or of desire. Thus will you attain the term of life without overmuch disquiet and affliction.—*Revue des Deux Mondes.*

## IMAGES AND SHADOWS.

BY W. J. YOUMANS, M. D.

SO much has been said lately of the wonders of spectrum analysis, that we are very apt to forget the other and equally marvelous properties of the agent by which it is produced. Spectrum analysis is a rare and curious experiment, but the more familiar effects of light which we daily experience are really just as wonderful, if we will but pause to reflect upon them. Science means knowledge, and the science of optics embodies our knowledge of light; but how much, after all, do we know of it? A great deal, undoubtedly, of its modes of action, but very little, if any thing, of its nature. We have an hypothesis or supposition about it, and work out ingenious conclusions, logically and experimentally, and say that they are proved; but how far are we from comprehending them.

That light moves at an amazing velocity, is shown in several ways; and all the methods bring us to about the same results which are expressed in numbers and are demonstrably true; but what finite mind can enter into the meaning of the statement that the luminous ray moves forward at the rate of 185,000 miles in a second of time? Between the two ticks of a second's pendulum, we are told that light

FIG. 1.

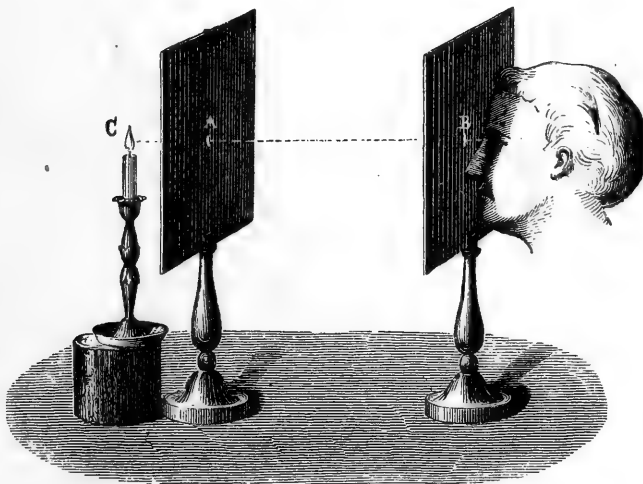

RECTILINEAR PROPAGATION OF LIGHT.

would pass round our globe seven and a half times. But who has a notion even of the dimensions of our globe? The number of thousands of miles through it and around it have been calculated, and the calculations harmonize with the whole body of astronomical knowledge; but we can form no adequate conception of such magnitudes. We patch together different shreds of our mental experience of large

things, and construct a symbolic idea which represents our planet, but we never grasp the reality in the immensity of its proportions.

Light is a force, and science holds that it is made up of impulses. Nature has been shown to conform all kinds of dynamical effects to rhythmical pulsing, or wave-like action and the impulses of light are held to be of the same kind. There are, at any rate, measurable effects which are unequal in the different colored lights, and the scale has been determined. In an inch of violet light it is shown that there are no less than 57,000 waves, a statement in which there is nothing extraordinary or impossible, as Nobert, the German optician, is in the habit of ruling his microscopical test-glasses at rates all the way from 100,000 to 200,000 per inch. But, when we are told that the ray enters the eye at the rate of 185,000 miles per second, and—as each inch contains 57,000 waves—that when we are looking at a violet object there are 699,000,000,000,000 beats upon the retina each second, the statement baffles all imagination: we may accept, but cannot understand it. In the attempt to penetrate the nature of light we are lost in the mysteries of the infinite. Yet the modes of its action have been determined, and they furnish the most splendid example we know of the inflexibility and exactitude of what are called the laws of Nature.

FIG. 2.

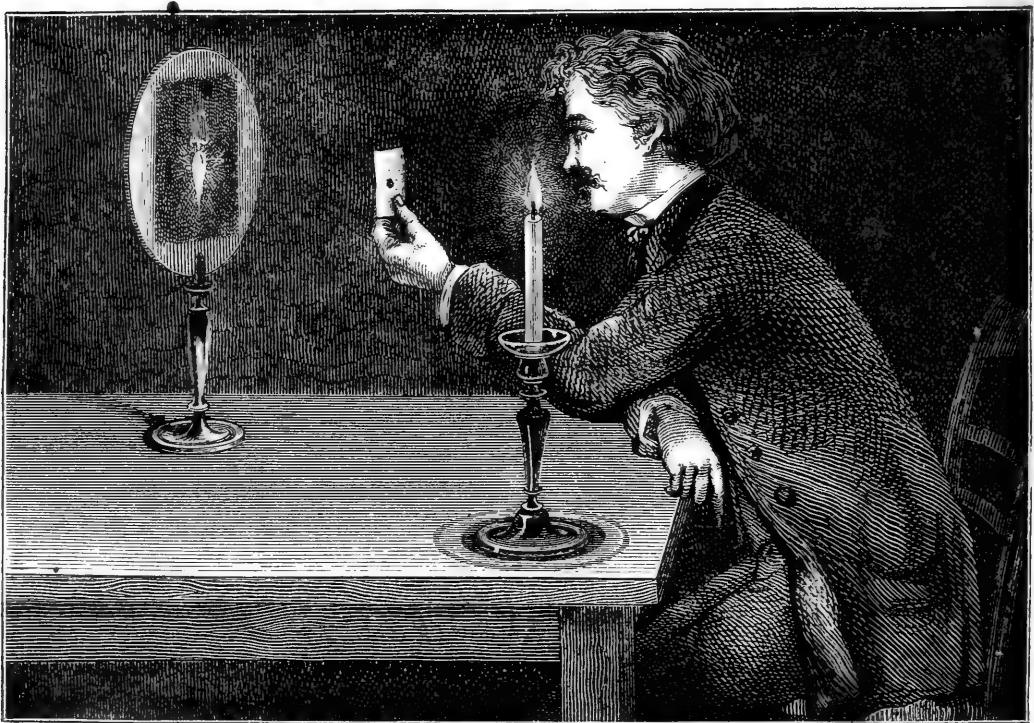

IMAGE FORMED BY A HOLE IN A CARD.

Man is placed in the midst of the universe, and is designed to have knowledge of it. He is impressible to outward agencies, and possesses a grand cerebral treasury-house for storing up these external impres-



sions. Touch, taste, smell, and hearing, are the senses by which he becomes acquainted with many properties of things immediately around him; but the universe is reported to him through the sense of vision and by the agency of light. Somehow, in their mysterious nature, the luminous rays from all sources, distant and remote, effect a change in the nerve-structure of the eye by which impressions are transmitted to the brain. Into that mode of action we cannot now enter, but will confine our attention at present to the property of light by which luminous images are produced. For it is, after all, the images of things we have to deal with. We know the external world in its distances, forms, and colors, because its visible objects are all duplicated in the eye. The cloud, the landscape, the cathedral, that excites our thought and kindles our feeling, is, in each case, but a picture recreated from the external object by the agency of light.

FIG. 8.

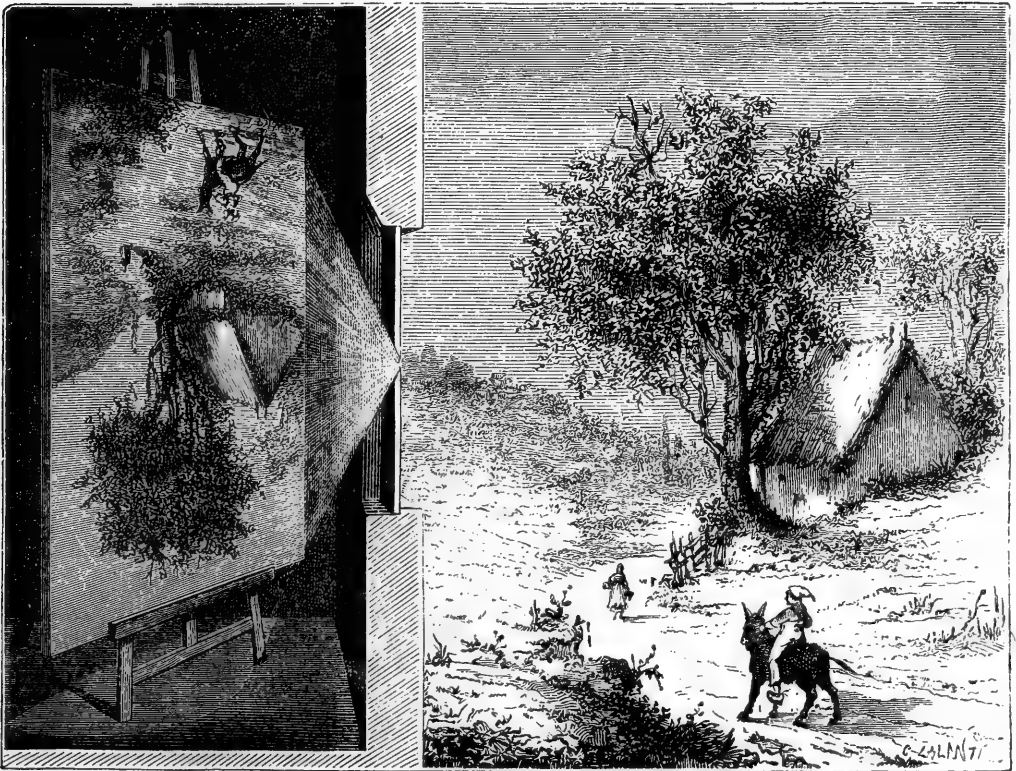

INVERTED IMAGE OF LANDSCAPE.

The first property, or law, of light, upon which the production of images depends, is simply that it moves in straight lines through any uniform medium that it can traverse. We are all familiar with the general fact that the path of light is rectilinear, but it may be accurately proved by a very simple experiment.

Two screens, A, B (Fig. 1), each pierced with a minute hole, are so arranged that the apertures are in a line with the flame of a candle, C. An eye, placed in this line behind the screens, is then able to see

the flame; but, if the eye, the candle, or either screen, be slightly displaced to the right or left, the ray is interrupted, and the flame becomes invisible.

This propagation of light in straight lines, though the first condition of the production of images, is not the only condition; for, in that case, the images of illuminated objects would be repeated everywhere, and, when the blinds were opened, a picture of the landscape might be thrown, through the window, upon the opposite wall of a room. For the formation of an image, the rays of an object must be collected and passed through an aperture. This is shown by a simple experiment illustrated in Fig. 2. A card is pierced with a large pin-hole and held between a candle and screen, when an image of the candle will be formed upon the screen in an inverted position. That the image must be upside-down is evident, if the rays take a straight course. A line from the top of the candle-flame through the puncture is prolonged to the bottom of the image, and another, from the bottom of the flame, crosses the first at the aperture, and strikes the top of the

FIG. 4.

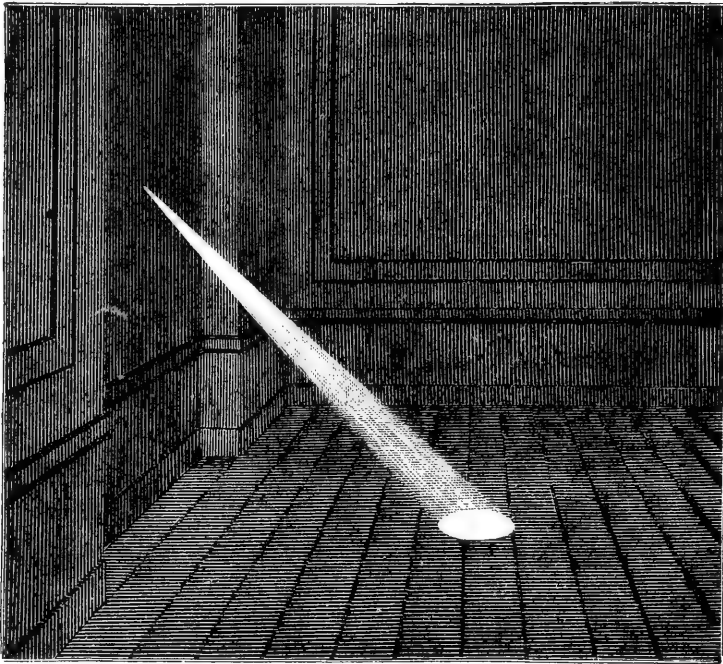

IMAGE OF SUN UPON THE FLOOR.

image. A line from the centre of the candle passes straight through and strikes the centre of the image, while lines from the two sides of the flame cross again, and are prolonged to the opposite sides of the image. Thus, as each point upon the screen receives only the light from a corresponding point of the flame, the image repeats the object in outline, color, and brightness, though in a reversed position.

This principle may be applied on a larger scale. Let a room be made quite dark, and a white screen be placed opposite a small hole

in the shutter. There will then be formed upon the white surface an inverted picture of the external objects, as shown in Fig. 3. They will appear of the natural colors, and the outlines will be sharper in proportion as the hole is smaller.

When the sun shines through a small orifice into a darkened room, a cone of rays is produced, as everybody has observed, by lighting up the particles of dust which are scattered in its course; for, if the air were quite clear, the track of the rays would be invisible. In this case an image of the sun is formed upon the floor or opposite wall by

FIG. 5.



IMAGES OF SUN FORMED BY FOLIAGE.

the crossing of the rays through the aperture, exactly in the manner of the production of the candle-image and the landscape-picture just described. The best condition for the formation of such an image is when the sun is low, and there is a white wall opposite to receive it; the image is then perfectly circular. But if the light falls upon the floor, as represented in Fig. 4, the cone of rays produces an oblong or elliptical image; the deviation from an exact circle depends upon the angle which the cone of rays makes with the floor. Such an image

may often be made instructive in observing solar phenomena. By closely examining it, it is sometimes possible to detect the presence of spots on the solar surface. Solar eclipses may be watched in the same way. As the moon gradually encroaches upon the sun's disk its progress can be traced by a corresponding change in the form of the image, which resembles that of the uneclipsed portion of the solar surface. In such observations, however, it will be remembered that the course of the movement is always reversed. It was in this way that the transit of Venus was first observed by Jeremiah Horrocks, November 24, 1639. He had calculated the time, which fell upon Sunday morning. He arranged his room for the observation, and then went to church, as he did not wish any secular interests to interfere with religious devotion. It is very probable, however, that Venus was mixed up with his devout meditations, for he hurried back from service, and was delighted to find that his calculations were verified, as the planet was already far advanced in its passage across the sun's face.

We are all familiar with similar images of the sun, of a round or oval outline, formed upon the ground where his rays shine through small openings in the foliage of trees, as illustrated in Fig. 5.

FIG. 6.

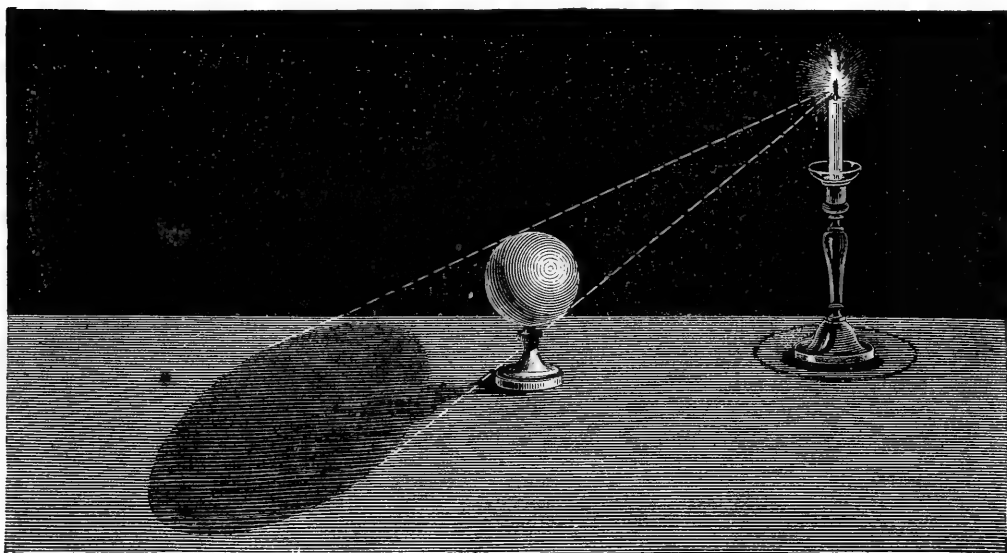

FORMATION OF A SHADOW.

The same property, that is, the rectilinear propagation of light, gives rise to a reverse effect, or a sort of dark image or shadow, although a shadow depending upon the absence of light is of course not properly an image. "Let the source of light be a luminous point, and let an opaque body be placed so as to intercept a portion of its rays (Fig. 6). If we construct a conical surface touching the body all round, and having its vertex at the luminous point, it is evident that all the space within this surface on the farther side of the opaque

body is completely screened from the rays. The cone thus constructed is called the shadow-cone, and its intersection with any surface behind the opaque body defines the shadow cast upon that surface. In the case which we have been supposing—that of a luminous point—the shadow-cone and the shadow itself will be sharply defined.”

Actual sources of light are not, however, mere points; they have finite and variable dimensions, and this complicates the effect in the geometry of shadows. These effects are well illustrated by the diagram (Fig. 7). Let the central sphere represent a source of light placed between two opaque spheres, one larger and the other smaller than itself. We shall then have two kinds of shadow, the total shadow or *umbra*, and the partial shadow or *penumbra*. If the opaque sphere, seen at the right in the diagram, be smaller than the luminous body, the umbra terminates at a finite distance depending upon the relative magnitudes and the proximity of the two bodies. If the opaque body is larger than the source of illumination, as illustrated in the left portion of the diagram, the cone of the umbra is projected to an infinite distance. The penumbral cones represented

FIG. 7.

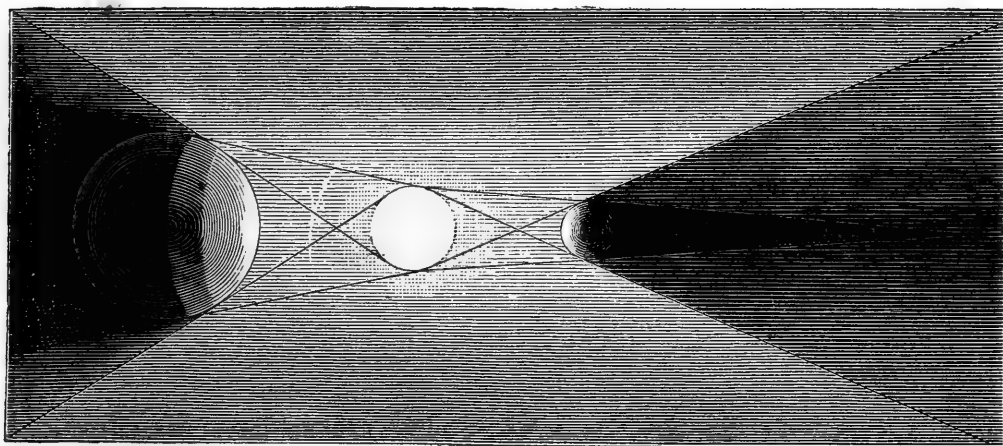

UMBRA AND PENUMBRA.

by a lighter shading, it is seen, are wider than the cones of total shadow, and include them. It will be noticed that all points lying within the penumbral cones are excluded from the view of *some portion* of the luminous body, and are thus partially shaded by the opaque bodies. Points that are very near the outer boundaries are very slightly darkened, if near the total shadow they are almost completely shaded. The penumbra is, therefore, not a uniform shadow, but gradually fades into darkness from its outer limit to the total obscuration of the umbra. It follows from this that the shadow of an opaque body falling upon a screen will not have a sharply-defined edge, but will show a transition from total shadow to the complete absence of shadow. To have the shadow clean and sharp at its edge,



it would be necessary to have the source of illumination a mere point. Of course the effect of such abrupt transitions from perfect illumination to total darkness, if it were the plan of Nature, would be most inconvenient and painful, if not destructive to the eyes. We are protected from this by the phenomena of double shadows, and the gradual passage from darkness to light, although each luminous ray moves undeviatingly in its straight line. Light cannot turn corners like sound. This is explained by the excessive shortness of the luminous as compared with sonorous waves. Sound-waves are so large that they flow around objects in the air, and consequently cast but feeble shadows, although Deschanel (from whose admirable work on "Natural Philosophy" our cuts are borrowed) states that Collodon, in his experiments on the transmission of sound through the water of the Lake of Geneva, established the presence of a very sharply-defined sound-shadow in the water behind the end of a projecting wall.

It is necessary to say, however, that the foregoing statement that light cannot turn corners is only true in the common and general experience of it. If we carry our experiments with light down to so fine a point that we reach the dimensions of its waves, it is then found that they are capable of bending round obstacles. If sunlight be allowed to pass through an exceedingly fine slit, and then to fall on a screen of white paper, colored bands appear, called diffraction fringes; that is, the white light, in its passage through the minute opening, has been interfered with and broken up into its component colors. We have here, however, a new order of effects which will require to be separately considered.

---

## VIVISECTION.

BY MICHAEL FOSTER, M. D., F. R. S.

PROFESSOR OF PHYSIOLOGY IN THE UNIVERSITY OF CAMBRIDGE.

IN the following pages I propose to inquire whether it is desirable that physiologists should continue the practice of what is commonly called vivisection, to which they have hitherto been accustomed. By vivisection I understand the operating with cutting instruments or by other means on the still living bodies of animals. The word "living" requires, perhaps, some further definition. In the long series of changes through which the body of a living animal passes, from full functional activity to complete decomposition, there are three chief stages, each of which may be arbitrarily taken as the end of life. There is the time at which consciousness is lost, the time at which the breath stops and the heart ceases to beat, and the time at which the muscles become rigid with the death-stiffening. The succession of the three events is always in the same order, but the interval of time be-



tween any two of them varies within very wide limits. For our purposes it will perhaps be best to take the second as marking the end of life, to say that an animal is still alive so long as the heart is beating, and air enters into and issues from the chest.

It is very desirable that a discussion, the decision upon which must be of the utmost importance to physiology at least, should not be turned aside to any false issues. The question whether vivisection is a bad thing is in no wise settled by asserting that there are many things equally bad. Thus, to say that the evil wrought upon animals in the name of science is but a flea-bite compared to that done in the name of sport, is simply to bring forward a *tu quoque* argument of no real worth, except to stop the mouths of particular opponents. When an ardent sportsman, or when one, no sportsman himself, but having a theoretical admiration of the pleasures of the field, declaims against vivisection, it may be worth while to remind such a one of some of the agonies of sport—of the scenes which accompany a *battue* or a pigeon-match; of wounded birds dragging their maimed bodies to some hidden covert, there to die a lingering death; of the piercing squeals of the hunted hare; of the last moments of the brave fox, when, after a fruitless struggle, the time comes for his living body to be torn by the pursuing hounds; to ask him how often a living object of sport is by some purposeful, sudden blow, humanely killed “to put it out of its misery;” to suggest to him, as a matter of reflection, that, had we any satisfactory measure of pain, it would be found that all the pain which physiologists have caused, since their science began, is less than that which the animal creation has suffered in the field from the hands of the members of the two Houses of Parliament since the last general election. It may be of use to say this to a sportsman; but vivisection is not thereby justified. It is no use saying it at all to those who are now agitating this question. They are equally opposed to cruelty in sport as to cruelty in science; but they are also wise in their generation. They see that there is far more hope of putting down the one than the other. Biologists and physiologists are at the present moment clearly in disrepute. To call them atheists, is to show one’s self a man of spirit and intelligence. Following out their own science, along the path Nature has pointed out to them, they have run counter to many established opinions and cherished views. Divorced by the divergence of their respective methods in large measure from the mathematicians and physicists, to whom orthodoxy is easy, accused of materialism, active in the support of Darwinism and evolution theories, believed by the many to have no faith—their position not a little resembles that of the Jews in the middle ages; they are just in the condition in which the accusation of cruelty is most tellingly made and most readily credited against them by a vulgar public. This the opponents of vivisection know full well; and therefore it is against the physiologists and not against the pigeon-

shooters that they make their complaint. They are even willing, at the present, to use the latter against the former. By-and-by, if they are successful in this, they will move against sport, on the ground that it is far more cruel and has far less justification than the vivisection which has been done away with.

Nor is it any use to tell a far larger class, the eaters of meat, that the pain which physiology has caused since the time of Galen is far less than that which in any one week is caused in butchers' shambles in providing flesh to fill the mouths of the people of London.

Nor is it, on the other hand, any use to say that because many physiologists are kindly, humane men in private life, therefore the accusation of cruelty brought against them must be false. I know a physiologist who, after a day spent in experimental work, may be seen sitting in the evening with a favorite cat on his lap, an old dog by his side, and a new one at his feet; but I would not therefore guarantee that he had not been cruel in the morning. He might be an angel in the bosom of his family, but a demon in the laboratory. I know a physiologist, of whom his friends have said that, had he not been so amiable, he might have made a noise in the world, and yet who at the present moment is being accused of brutal cruelties. I feel that the accusation might be true.

Nor is it of any use to say, though it may be said with perfect truth, that a great deal of the present agitation against vivisection is one of the many fruits of a mawkish sentimentalism which is stealing over the present generation, and by a lessening of manliness is curtailing the good effects of increased enlightenment. The foolish of this world are often used to correct the wise; and actions brought about by a wrong sentimentalism may be in themselves right and good.

The question whether it is desirable that man should continue to inflict the pains of death, or pains without death, on other animals, and, if so, within what limits, is one which must be argued out on its own merits alone, and the discussion of it will not be advanced by irrelevant considerations such as these on which we have dwelt.

There are two aspects of the inquiry—one from the side of man, the other from the side of the animal. Let us first consider the question from the point of view of the animal.

We have to determine the principles which govern or should govern the conduct of man toward animals. One broad principle may be briefly stated: Unless man destroys animals, animals would soon destroy man. Mr. Tennyson has told us—

“Nature is one with rapine, a harm no preacher can heal;”

and Mr. Darwin has shown that the lives of all living beings are shaped by “the struggle for existence.” Man's life is a struggle for existence with his fellow-men, with living animals and plants, and with

the lifeless forces of the universe. The very conditions of his existence lay upon him the burden, and in so doing give him the right, to use the world around him, the lives of animals included, to aid him in his strife. Imagine the results of forbidding man to take away the lives of animals. Suppose, for instance, the whole human race were to form itself into a Society for the Prevention of the Destruction of Tigers. How many generations would pass before "the last man" provided a tumultuous crowd of tigers with the last human meal?—possibly the indefatigable secretary of the Society sealing with his death his loyalty to the cause. Or, since tigers, like man, are carnivorous, and might therefore be supposed more worthy of death than herbivorous creatures, let us suppose the efforts of the Society to be directed toward the preservation of sheep. How many generations would pass before the face of the earth were covered with woolly flocks, and man were driven to lead a laborious, frugivorous, arboreal life on the tree-tops, or to earn a scanty subsistence on resuscitated *Pfahlbauten*, as being the only places where the necessities of the sheep would permit him to dwell? Did the reader ever by chance descend, at early dawn, into the kitchen and watch the convulsive agonies of a writhing heap of cockroaches drowning in the watery trap set for them by the cook overnight? What a scene of unutterable woe is that when judged from the stand-point of the cockroach! But, if man were to deny himself the right of vivisection or vivipression over the vermin which infest his home and bed, what would come of it?

To be serious: man, if he is to live and prosper, *must* kill other animals. It is a duty laid upon him by the nature of things; a duty, and therefore a right. Self-preservation demands it. But what do we mean by self-preservation? Can we draw a line and say that he is justified in slaying an animal for this purpose and not for that? We can only do so by applying the test of whether the death of the animal is useful to him or not. Whenever or wherever the death of an animal is of advantage either to himself or to the human society of which he is a unit, he is justified in slaying that animal.

The success of the human race in the struggle for existence depends on man's being well fed; man is therefore justified in slaying and eating a sheep. The success of the human race in the struggle for existence is dependent on knowledge being increased; man is therefore justified in slaying a frog or a rabbit, if it can be shown that human knowledge is thereby enlarged.

Death is in itself painful. It is only by special means that the pangs amid which the ties of life are loosened can be done away with. The slaughter of an animal is therefore of necessity painful, except in the special cases where means have been taken to do away with pain. In ninety-nine cases out of a hundred, when an animal is slaughtered by man, it is the death of the animal which benefits man, the pain itself which accompanies the death does him no good at all. While

justified, therefore, in killing the animal, he is not justified in causing it pain. He is bound, in fact, to kill the animal in such a way as to cause as little pain as is consistent with his own interest. The death of a sheep in a butcher's slaughter-house is painful; but men cannot therefore be said to do wrong in killing a sheep for food. They kill it with as little pain as is under the circumstances possible. They could not make the pain less, except by the introduction of elaborate and costly methods which would probably ruin the butcher or spoil the meat, or at least, in the present state of our knowledge and of the market, do damage to the interests of mankind. The death of an ox, again, is more painful than that of a sheep; but men do not therefore feel bound to live on mutton alone. They consider that the advantages of a mixed diet of beef and mutton justify them in inflicting that additional quantity of pain which is suffered whenever an ox is felled.

In short, this, under one aspect, is a selfish world. The struggle for existence is its guiding principle. If we believe that man is to govern the world, and he must either govern or succumb, then we must be prepared to use animals selfishly, if you please to call it so—to use animals for our advantage—to kill them when we have need of their deaths—to kill them with pain when the pain is for our benefit; and, inasmuch as the greater includes the less, to inflict pain without death where their pain does us good.<sup>1</sup> Our good is, in fact, the rule of our conduct toward animals. Whenever an animal is killed by man, or suffers pain at the hand of man, without benefit to man, or where the same benefit could be gained without the death or without the pain, then the death or the pain can be no longer justified. The man who inflicts them is a cruel man; he no longer does good, but harm, to humanity, and humanity ought to stop his hand.

I feel that I ought almost to apologize to the reader for having spent so much of his time over what are almost truisms; but so many absurd statements are continually being made, and so many whimsical ideas broached, that it seemed desirable to have a clear understanding concerning the principles which should guide our general conduct toward animals before discussing the special subject of vivisection.

We have now to inquire whether the deaths and pains which the word vivisection implies are, or have been, wrought for the benefit of mankind, inasmuch as they have led to knowledge and power which could not otherwise have been gained; or whether they had not been wrought for the benefit of mankind, inasmuch as they have not led to knowledge and power, or the power and knowledge might have been gained in some other way, or, being gained by many deaths and much pain, have been so small that mankind could well have done without

<sup>1</sup> Some writers have urged that while man is perfectly justified in *killing* any number of animals, he is not justified in causing *pain*. From the point of view of the animal this is simply a grotesque absurdity; from the point of view of man we shall have to speak of it later on.

them. I introduce the word death as well as pain, because, in spite of the etymology of the word, and the fact that vivisection suggests to the public mind pain only, and not death at all, the truth is, that in at least the great majority of cases vivisection does or ought to mean death only, and not pain at all. In the minds of those ignorant of physiology—and they are foremost, if not alone, in blaming vivisection—much confusion has arisen from the different meanings attached to the words “life” and “living.” I alluded to these in the beginning of this paper. To many such it is perhaps a revelation to learn that an animal may be kept alive—that is, with its heart in full working order, and its respiratory movements continuing with perfect regularity—for hours and hours after all signs of consciousness have disappeared. All operations performed on such an animal would come under the term vivisection; but, in the total absence of all signs of consciousness, it would be absurd to speak of pain. It would perhaps be a still greater revelation to such to learn that a frog, at a later stage in the series of events which we class together as death—when its brain and spinal cord have been instantaneously destroyed by an operation the pain of which may be said to be infinitesimal, and its heart removed at a time when feeling is impossible—may yet be made by proper means to kick and jump and move its body about in almost all possible ways. Any operation performed on the body of such a frog would by many be still called vivisection; but, to speak of such a mere mass of muscle and nerve as suffering pain, is about as truthful and rational as to say that it is cruel to cut down a tree, though a silly, ignorant looker-on might shriek when the leg moved, for about the same cause and with the same reason that the African grovels before his fetich.

Did the reader ever see a rabbit completely under the influence of chloral? Lying prostrate, with flaccid limbs, with head sunk back on the limp neck, motionless and still, at first sight, it seems quite dead and gone. But a gentle heaving of the body, a rise and a fall every few seconds, tells you that it still breathes; and a finger placed on the chest may feel the quick throb of the still beating heart. You pull it and pinch it; it does not move. You prick with a needle the exquisitely-sensitive cornea of its eye; it makes no sign, save only perhaps a wink. You make a great cut through its skin with a sharp knife; it does not wince. You handle, and divide, and pinch nerves which, in ourselves, are full of feeling; it gives no sign of pain. Yet it is full of action. To the physiologist, its body, though poor in what the vulgar call life, is still the stage of manifold events, and each event a problem, with a crowd of still harder problems at its back. He therefore brings to bear on this breathing, pulsating, but otherwise quiescent frame, the instruments which are the tools of his research. He takes deft tracings of the ebb and flow of blood in the widening and narrowing vessels; he measures the time and the force

of each throb of the heart, while by light galvanic touches he stirs this part or quiets that; he takes note of the rise and fall of the chest-walls, as they quicken or grow slow, as they wax or wane, under this influence or that; he gathers the juice which pours from one or another gland; he divides this nerve, he stimulates that, and marks the result of each; he brings subtile poisons to bear on the whole frame, or on parts; and, having done what he wished to do, having obtained, in the shape of careful notes or delicate tracings, answers to the questions he wished to put, he finishes a painless death by the removal of all the blood from the body, or by any other means that best suit him at the time. I am not exaggerating when I say that this is at the present day one of the commonest forms of vivisectional experiment; this is what newspaper writers speak of as "torture," and, on the strength of it, accuse cultivated physiologists of barbaric cruelty.

A dog under chloroform or morphia may be brought to very nearly the same condition as a rabbit under chloral; but, as far as my experience goes, the same long duration of complete quiescence is maintained with greater difficulty. Dogs sometimes howl under chloroform or morphia when nothing is being done to them, and under circumstances in which they can be suffering no pain. At the moment when the chloroform begins to take effect upon them, when probably confused carnivorous visions chase through their brains, the howling is often excessive. Any one who knows any thing about the administration of chloroform to human beings, is well aware how frequent cries and noises are in the stage of excitement, and how little dependence can be placed on them as signs of pain.

In a large number of cases, then, where anæsthetics of one kind or another are used, vivisectional experiments cause no pain at all; and, as far as I know, in this country, at least, physiologists always use anæsthetics where they can. They do so not only for the sake of the animal, but also for the sake of the experiment itself. Unless they are studying actual manifestations of feeling, pain, with all its consequences, is a disturbing element which must by all possible means be eliminated, if the experiment is to have its due value. The apparent lifelessness of the animal is the physiologist's opportunity; struggling limbs would utterly defeat his aims, and a sudden start might wreck his whole experiment. Chloroform and other anæsthetics have immensely lessened human suffering, not only by simply diminishing pain, but even still more by putting it in the power of the surgeon to perform operations which he otherwise would not dare to attempt. In the same way they have powerfully aided the progress of physiology, by rendering possible new experiments, and by allowing the investigator to analyze securely phenomena which otherwise would, perhaps forever, have remained confused through the disturbances caused by pain.

There are some experiments, however, requiring vivisection, in



which the use of chloral or other anæsthetics is, for various reasons, inadmissible or undesirable. These form two classes. In the first and most numerous, the experiment is generally a short one, and quickly carried out, and the pain slight and transient. It is, of course, impossible for any one to judge truly of the pain felt by any other body, and we may err in two ways in estimating the pain felt by animals. We may over-estimate or under-estimate it. Perhaps a rough but tolerably safe test of great pain or distress may be gained by noting whether the animal is willing to eat or not. When a rabbit, for instance, not previously starved, begins to munch carrots immediately after an operation, or even continues to munch during the greater part of the time the operation is being performed, it is only fair to conclude that the operation cannot be very painful. I may add that, in the experience of experimental physiologists, the skin of the dog and the rabbit—allowance being made for individual peculiarities—is not nearly so sensitive as the human skin.

The second class of experiments carried on without anæsthetics—those entailing a considerable amount of pain—are not only by far the least numerous, *but must of necessity become less and less numerous as physiology advances*. The end which the physiologist has in view is to analyze the life of any being into its constituent factors. As his science advances, he becomes more and more able to disengage any one of these factors from the rest, and so to study it by itself. He can already, as we have seen, study the complicated phenomena of the circulation of the blood, of respiration, of various kinds of movement, quite apart from and independent of the presence of consciousness. As his knowledge widens and his means of research multiply, this power of analysis will grow more and more; and by-and-by, if physiology be allowed free scope for its development, there will come a day when the physiologist, in his experimental inquiries, will cause pain then, and then only, when pain is the actual object of his study. And that he will probably study best upon himself.

At the present day, the greatest amount of pain to animals is probably caused in experiments which perhaps hardly come under the title of vivisection—experiments in which the effects of starvation or of insufficient food, or the actions of poisons, are being studied. These, however, lead to valuable results. The pain which is the greatest in amount, and the least worthy in object, is the pain which comes to animals whose bodies have been used as tests to ascertain the poisonous nature of some suspected material; but this is a matter of the witness-box, not of physiology.

We may conclude, then, that physiologists are the cause to animals of much death, of a good deal of slight pain, and of some amount of severe pain. A very active physiologist will, for instance, in a year, be the means of bringing about, for the sake of science, as much death as a small village will, in a week, for the sake of its mouths and its

fun, and will give rise to about as much pain as a not too enthusiastic sportsman in a short sporting-season.

We have now to ask: What justification does he plead for this death and this pain? What good to mankind is thereby wrought which could not otherwise be gained?

His answer is, that the science of physiology is thereby advanced; that our knowledge of the laws of life has, in the main, been won by experiments on living animals. He, of course, cannot, and no one can, tell the "might have been." Without any such experiments, physics and chemistry, aided by mathematics, might have synthetically resolved the problems of life (though even then it might be said that both physics and chemistry sprang from the older biologic lore, and not so long ago a common physiological preparation, the muscle and nerve of a frog, started a new epoch in physics); but, as a matter of history, experiments on living animals have been the stepping-stones of physiological progress.

The great Vesalius, the founder of modern anatomy, turning his thoughts to the uses of the structures he had so well described, saw clearly that the problems opening up before him could be settled only by vivisection. In his great work, "*De Corporis Humani Fabrica*," may be read the evidence, not only that he performed experiments on living animals, but that, had he not in so inscrutable a way forsaken the arduous pleasures of learning for the gossip of a court, those experiments would have led him up to and probably beyond the discovery which years afterward marked an epoch in physiology, and made the name of Harvey immortal. He, indeed, sowed the seed whose fruit Harvey reaped. The corner-stone of physiology, the doctrine of the circulation of the blood, was not built up without death and pain to animals. To-day, it is true, much of the evidence touching the flow of blood may be shown on a dead body, yet the full proof cannot be given even now without an experiment on a living creature; and certainly Harvey's thoughts were guided by his study of the living, palpitating heart, and the motions of the living arteries, quite as much as by the suggestions coming from dead valves and veins.

After Harvey came Haller, whose keen intellect dispersed the misty notions of the spiritualists, and by the establishment of the doctrine of "irritability" laid the foundations of the true physiology of the nervous system: he too, in his work, wrought death and suffering on animals.

Another great step onward was made when Charles Bell and Magendie, by experiments on animals more painful than any of the present day, traced out the distinction between motor and sensory nerves; and yet another, when Marshall Hall and others demonstrated by vivisections the wide-spread occurrence and vast importance of reflex actions.

What was begun with death and pain has been carried forward by the same means. I assert deliberately that all our real knowledge of

the physiology of the nervous system—compared with which all the rest of physiology, judged either from a practical or from a theoretical point of view, is a mere appendage—has been gained by experiment, that its fundamental truths have come to us through inquiries entailing more or less vivisection. By meditating over the differences in structure visible in the nervous systems of different animals, a shrewd observer might guess at the use of some particular part; but till verified by experiment, the guess would remain a guess; and experiment shows that such guesses may be entirely wrong. Where experiment has given a clew, careful observations have frequently thrown light on physiological problems. Without the experimental clew, the phenomena would ever have remained a hopeless puzzle, or have served to bolster up some baseless fancy. What disease, or what structure in what animal, could ever have made us acquainted with that “inhibitory” function of the pneumogastric nerve which the vivisectional experiment of Weber first detected? What a light that one experiment has thrown on the working of the nervous system! What disease could have told us that which we have learned from the experiments of Du Bois-Reymond and of Pflüger? Where would physiological science be now if the labors of Flourens, Brown-Séguard, Schiff, Vulpian, Goltz, Waller, and others, were suddenly wiped away from the records of the past? Yet each of these names recalls long series of experiments, some of them painful in character, on living animals.

I repeat, take away from the physiology of the nervous system the backbone of experimental knowledge, and it would fall into a shapeless, huddled mass.

The chemistry of living beings, one would imagine at first thoughts, might be investigated without distressing the organisms which formed the subjects of research. The labors of Lavoisier and Priestley, who first made clear the chemistry of respiration, if they entailed no use of the knife, caused at times a no less painful suffocation; while the great advances which have been made in this branch of the study during the last quarter of a century, and are still being made, necessitate almost daily vivisection, in order that the gases of the blood may be studied in exactly the same condition as they are in the living body. Even still more bloody has been the path by following which we have gained the knowledge we now possess of the chemistry of digestion and nutrition. I have only to mention the names of Bidder, and Schmidt, and Bernard, to call to the mind of the physiological student important results, nearly all reached through vivisection. The shifts and changes of the elements within our body are too subtle and complex to be divined from the results of the chemical laboratory; the physiologist has to search for them within the body, and to mark the compounds changing in the very spot where they change; otherwise all is guess-work.

Among the labors of the present generation, none perhaps have already more far-reaching results, none hold out more promise of fruit in the future, than those which bear on the influence of the nervous system over the circulation of the blood and over nutrition. The knowledge we are gradually acquiring of the subtile nervous bonds which bind together the unconscious members of the animal commonwealth, which make each part or organ at once the slave and guardian of every other, and which with cords of nervous sympathy draw each moiety of the body to work for the good of all, is putting a new aspect on physiology, and throwing many a gleam of light into the very darkest regions of the science. The words "inflammation" and "fever," bandied about of old as mystery-words, sounding much but signifying little—shuttlecocks tossed to and fro from one school of *doctrinaire* pathologists to another—now at last, through the labors of modern physiology, seem in a fair way of being understood. That understanding, when it is complete, will have been gained step by step through experiments on living animals, one of the first of which was Claude Bernard's research on vaso-motor nerves.<sup>1</sup>

There still remains the question, What good does physiology bring to mankind? Of the value of physiology as a not insignificant segment of the circle of universal knowledge, nothing need be said; where saying aught is necessary, it would be useless. Nor need much be said concerning the practical value of physiology as a basis for the conduct of life. So long as men refuse to learn or to listen to physiology in order that they may the better use their bodies, it would be hopeless and useless to talk of the day when they may come to it for instruction how to form their minds and mould their natures. It will be enough for my present purpose to point out briefly the relations of physiology to the practical art of medicine.

These are twofold. In the first place, the medical profession is largely indebted to physiology on account of special discoveries and particular experimental researches. If we regard the profession simply as a body of men who possess or should possess a remedy for every disease, this may seem an exaggerated statement. Many of the remedies in use or in vogue at the present day have been discovered by chance, borrowed from ignorant savages, or lighted on by blind trials. Physiology can lay no claim to the introduction of opium or quinine. Where specific remedies have been suggested by physiologi-

<sup>1</sup> The great importance of the vaso-motor system justly led Mr. Huxley to introduce into his "Elementary Lessons in Physiology" Bernard's fundamental experiment with some such words as "a rabbit may be made to blush artificially by dividing the sympathetic nerve." A writer, apparently biased by the memories of his own boyhood, has accused Mr. Huxley of thereby dangerously inciting boys and girls to cruelty, as if the division of the sympathetic nerve were the sort of thing a school-boy might do with a pocket-knife and a bit of string. Is it any use to enlighten the malevolent ignorance of such minds by telling them that many physiological experiments require such skill and care as make ordinary surgical operations seem rough and easy proceedings?

cal results or theories, it has not seldom happened that the remedies, though useful, have been given for a wrong reason, or have done good in a way which was not expected.

But if we look upon the medical profession as a body of men, cunning to detect the nature and to forecast the issues of the bodily ills under which we suffer, skillful in the use of means to avoid or to lessen those ills, rich in resources whereby pain is diminished and dangerous maladies artfully guided to a happy end, then we owe physiology many and great debts. Did the reader ever suffer, or witness others suffer, with subsequent relief, a severe surgical operation? If so, let him revere the name of John Hunter, the father of modern surgery. But Hunter was emphatically a physiologist; his surgery was but the carrying into practice of physiological ideas, many of which were got by experiments on living animals. Does the reader know that in all great surgical operations there are moments of imminent danger lest life steal away in gushes of blood from the divided vessels, danger now securely met by ligatures scientifically and deftly tied? Does he know that there was a time when the danger was imperfectly met by hot searing-irons and other rude means, and that the introduction of ligatures, with their proper application, is due to experiments, cruel experiments, if you like, on dogs and other dumb animals, experiments eminently physiological in their nature, about which much may be read in the book of "Jones on Hæmorrhage?" Even now, year by year, the scientific surgeon, by experiments on animals, is at once adding to physiological knowledge and bettering his treatment of wounded or diseased arteries. Has the reader seen any one once stricken by paralysis, or bowed down by some nervous malady, yet afterward made whole and brought back to fair, if not vigorous, health? The advice which turned such a one toward recovery was based on knowledge originally drawn from the vivisectional experiments of physiologists, and made safe by matured experience. Or has he watched any dear friend fading away in that terrible malady diabetes, after rejoicing that for a season he seemed to be gathering strength and ceasing to fail, even if not regaining health? The only gleam of light into that mysterious disease which we possess, came from the vivisectional researches of Claude Bernard on the formation of glycogen in the liver; and by judiciously acting upon the results of those researches the skillful physician can sometimes stay its ravages. He cannot cure it even now; and unless some empiric remedy be found by chance, will never cure it, until, by the death of many animals in the physiological laboratory, the mystery of the glycogenic function of the liver be cleared up.

But why need I go on adding one special benefit to another? They may all be summed up in one sentence, which embodies the whole relation of physiology to the medical profession.

The art of medicine is the science of physiology applied to detailed

vital phenomena by the help of a wisdom which comes of enlightened experience, and an ingenuity which is born of practice. Were there not a single case on record in which physiology had given special and direct help to the cure of the sick, there would still remain the great truth that the ideas of physiology are the mother-ideas of medicine. The physiologist, unincumbered by the care of the sick, not weighted by the burden of desiring some immediate practical result, is the pioneer into the dark places of vital actions. The truths which he discovers in his laboratory pass over at once to the practitioner, busy in a constant struggle with the puzzling complexity of corporeal events: in his hands they are sifted, extended, and multiplied. The property of the physiologist alone, they might perhaps lie barren; used by the physician or surgeon, they soon bear fruit. The hint given by a physiologist of the past generation becomes a household word with the doctors of the present, and their records in turn offer rich stores of suggestive and corrective facts for the physiologists of the generation to come. Take away from the practical art of medicine the theoretical truths of physiology, and you would have left a crowd of busy idlers in full strife over fantastic ideas. The reader has laughed with Molière over the follies of the *doctrinaire* physicians of times gone by. He has to thank experimental physiology that he has not the same follies to laugh over and to suffer from now. The so-called practical man is ever prone to entangle himself in and guide his conduct by baseless speculations. Such has been the case with medicine. The history of medicine in past centuries is largely occupied with the conflicts of contending schools of pathology—schools which arose from this or that master putting forward a fancy, or a fragment of truth, as the basis of all medical judgment. These have given place in the present century to a rational pathology, which knows no school and swears to the words of no master, but is slowly and surely unraveling, bit by bit, the many separate tangled knots of disease. They have given place because men have come to see that maladies can only be mastered through a scientific comprehension of the nature of disease; that pathology, the science of disease, being a part of, is inseparable from, physiology, the science of life; that the methods of both are the same, for in each a sagacious observation starts an inquiry, which a well-directed series of experiments brings to a successful end.

Many, if not most, of these experiments must be made on living beings. Hence it is that animals are killed and suffer pain, in order that physiological knowledge may be increased, and disease made less.

Take away from the art of medicine all that with which physiology has enriched it, and the surgeon or the physician of to-day would be little better than a mystery-man, or a quack vender of chance-gotten drugs. Take out of the present system of physiology all that has been gained by experiments on living animals, and the whole structure



would collapse, leaving nothing but a few isolated facts of human experience.

As far as we can see, what has been will be. The physiology of the future, if not hampered by any ignorant restraint, will, out of the death of animals, continue to press further and further into the mystery of—and year by year bring the physician, and not the physician only, but every one, power to prolong, to strengthen, and to purify—the life of man. By no other way can man hope to gain this end. He is thereby justified for the death he causes and the pain he gives.

We have yet to consider this question in its other aspect; we have to examine not only the effects of vivisection as far as animals are concerned, but also its influence on man himself. Little, however, need be said. Necessary vivisection, we have shown, cannot be called cruel. The question of the necessity of any particular case can only be judged by the investigator himself. I content myself with asserting that any attempt to draw up, for the guidance of others, a general definition of necessary and unnecessary vivisection, must prove utterly futile. Only he who is making an inquiry knows his own needs. If he experiments recklessly and needlessly, he becomes cruel, and, being cruel, will thereby be the worse. But, if he experiments carefully and heedfully, never causing pain where it could be avoided, never sacrificing a life without having in view some object, to attain which there seemed no other way, remembering that whoever “tortures” either dead or living nature carelessly will get no true response, there is no reason why his moral nature should suffer even ever so little tarnish. On the contrary, experience teaches us that earnest physiologists, who have killed animals in the single hope of gaining new truths or of making old ones plain, have grown more gentle and more careful the longer they worked and the more experiments they made.

The effects of vivisection on the moral nature of man may fairly be tested by experience. There are in this country several physiologists—myself among the number—who have for several years performed experiments on living animals. We have done repeatedly the things which a distinguished lady has seen fit to say “are best spoken of as nameless.” I can confidently appeal to all who know us, whether they have seen any deterioration in our moral nature, as the result of our work; whether we are to-day less careful of giving pain than we were when we began to experiment; whether they can trace in us any lessening of that sympathy with dumb animals, which all men should feel even in the very thickest of the struggle for existence.—*Macmillan's Magazine.*

## A FEATHER.

BY W. K. BROOKS,  
OF THE AGASSIZ MUSEUM.

ALTHOUGH not by a balloon, yet the Atlantic has been crossed in the air, and "what has been can be." There are enough well-authenticated cases of the occurrence of American wild birds on the west coast of Europe to prove that the trip can be made by birds, and it is probable that successful navigation of the air will be the fruit of careful study of that natural flying-machine, a bird's wing.

Every person who has not given more than a passing thought to the mechanism of flight is confident that he understands the whole subject, and tells you, if you ask, that the bird rows through the air with its wings, and that our lack of available force and of a sufficiently strong and light material is the only difficulty in the way of a successful flying-machine.

A very little study of a bird's wing and its action will show that it is not by any means simple, and that every part and every curve and angle has a use, and helps in the performance of the function of the whole, which function is not yet perfectly understood, but does not in the least resemble the action of a paddle or oar. We shall also learn that all attempts to construct flying-machines have been made with an utter disregard of every thing that a wing might have taught. To this sweeping assertion I know of only two exceptions; a boy's kite, and the little circle of card-board which runs up the kite-string in such a mysterious way, bear a very slight resemblance to a wing, in their mode of action, and may contain the germ of a successful flying-machine.

To point out some of the facts already known about flying is one of the objects of this paper; another is to show how much there is to be learned about any natural object, and the way to set about it; for he who knows all that is to be learned *about* a wing has a good store of useful information, but he who knows all that may be learned *from* a wing is a wise man.

Let us examine a feather. When I say "examine a feather," I mean, let "every one take the trouble to pull a quill-feather from an old duster, or find an old quill-pen, or in some way get possession of an actual feather, to see for himself what I wish to show; for, if what I have to say is not worth this trouble, it is not worth reading at all.

Having found your feather, notice, first, the great strength of the shaft, compared with its lightness, and how secured by placing almost all the material on the outer wall of the quill. Notice, too, that the quill, where strength is most necessary, is tubular, while the rest of the shaft has a groove on its lower surface, and tapers toward the tip,

so that it may be bent downward very easily by pressure near the tip, but does not bend so easily the other way. Notice, too, that the shaft is not straight, but bent so that the upper surface of the feather is convex, and the lower concave. We shall soon find a meaning in all these properties.

Passing now from the shaft to the vane, we see that the two sides are not alike: one edge, or vane—the one on the right-hand side of every feather in the right wing, that is, the side nearest the tip of the spread wing—is short and stiff, while the vane on the other side of the shaft is broad and flexible; and, by examining the feathers in their places in the wing, we see that the broad inside edge of the first or outside feather passes under the stiff, narrow outside edge of the next feather, which has its own inner edge supported in the same way by the third feather, and so on through the wing. When the wing is flapped downward through the air, the broad edge of each feather is pressed against the inflexible narrow edge of the feather next it, and the whole wing is thus made air-tight; but, when the wing is moved the other way, the broad edges have nothing to support them, and are pressed downward, so that the air can pass between the feathers.

The vane is also made up of separate pieces. If it is carefully examined, separate pieces, or “barbs,” will be seen running off from each side of the shaft at a slight angle, and parallel to each other, united in such a way as to form two flat plates, the vanes. These barbs are fastened to each other quite firmly, but, if part of the vane is pulled down toward the quill, the barbs will separate at last with a tearing sound, and if this is repeated in a few places it will give the feather a very draggled appearance, and it will seem torn beyond possibility of restoration; but, if it be drawn gently between the fingers two or three times from base to tip, the broken places will unite so perfectly that it may be quite impossible to find them again. The working of the mechanism by which the attachment is made is so perfect that it need only be noticed to be admired, and careful examination will reveal the simple means by which it is accomplished.

Each barb, when examined with a lens, is seen to bear some resemblance to the whole feather; like the feather, it has a shaft running longitudinally, and a vane on each side of it. These vanes are unequal, as in the whole feather, and they are composed of separate pieces running off from the shaft, and called “barblets,” because they are to the barb what the barbs are to the whole feather. On the side of the barb toward the tip of the feather the barblets run out from the shaft of the barb nearly at right angles, and send off from their lower surfaces little hooks at regular intervals, all pointing downward; on the other side of the barb the barblets have no hooks, and, instead of being set at a large angle with the shaft, they are almost parallel with it, so that where they meet and run under the hooked

barblets from the other side of the next barb they cross at right angles, and each hook falls directly over one of the straight barblets and fastens to it.

FIG. 1.

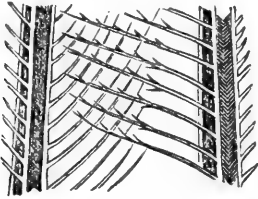

PART OF TWO BARBS FROM FEATHER OF BIRD-OF-PARADISE, showing Barblets and the Hooks which fasten them (magnified).—(From *Hardwick's Science Gossip*.)

FIG. 2.

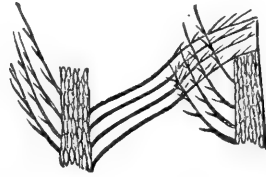

BARBS, BARBLETS, AND HOOKS, FROM FEATHER OF GOOSE (magnified).

This is a very beautiful adaptation, but what is the use of it? Why could not the whole vane be made in one piece? It is commonly said that its purpose is the same as that accomplished by the overlapping of the feathers, to form valves which shall allow the air to pass in one direction but to resist its passage in the other. Unfortunately, the hooks are arranged in just the wrong way for this, for pressure from above tightens them, while pressure from below tends to loosen them, although they are too firmly fastened to be easily unfastened. The true use of the separate pieces seems to be to secure that all-important property, the greatest strength, by the least use of material; and it is done in precisely the way that men have employed for securing the same end.

A scantling of wood placed on its edge will support a much greater weight than one placed on its side; so, in laying a floor, instead of laying all the boards on their sides, which would not be strong enough, or placing them all on their edges, which would use too much wood, the plan is to place on edge a sufficient number, and on these to lay the floor of boards on their sides.

The method employed in the feather is still better than this: the shaft of each barb is flattened vertically, but, instead of a separate floor laid on these, the top of each rafter, or barb, is split, and these split portions are bent down and bound to each other by the hooks already spoken of, arching over the spaces between the barbs, in exactly the way that the arches of masonry span the spaces between the iron girders of a fire-proof floor.

Before we shall be prepared to understand the way the feathers act in flight, we must examine the way in which they are placed in the wing. The anterior edge of the wing is a firm rim of bone, and the quills are fastened to this rim, with the flexible end of each feather projecting backward with nothing but adjacent feathers to support it, so that the posterior border of the wing bends very easily. The feathers are of such a shape that the wing is convex on its upper surface, and concave below.

When the wing is moved downward through the air, the feathers are pressed together; the air is confined in the concave surface of the wing, and the bird is raised up; but, when the wing is moved up to repeat the stroke, the air rushes down between the feathers. This is the paddling motion popularly supposed to be flight, but really only a small part of it. The air, being gaseous, does not remain passive under the descending wing, but tends to slide out, and as the front is unyielding, while the back is flexible, the air finds this exit, bending up the tips of the feathers, and sliding out backward and upward, while the feathers, and with them the bird, slide forward and downward. The bird can rotate its wings as well as flap them, and, by fixing them at such an angle that the fall occasioned by sliding shall just balance the lift given by the downward flap, it is able to move forward without rising or falling, although the motion of its wings is up and down; and, by changing the inclination of the wings a little, it can go up or down at the same time that it moves forward.

This is only an outline of what is known of the mechanism of flight—and many parts of the process are not yet understood—but we know enough to be able to appreciate the wonderful way in which every part, and every curve and outline, is adapted to its use; and the attention of thoughtful men has long been attracted by these and the countless similar adaptations in Nature, and many of the greatest thinkers have occupied themselves in attempts to understand the way in which they have been produced. Some have decided that adaptation implies design; and hence these adaptations must be the direct work of a personal designer and creator; but adaptation alone does not always imply design. I may go into the woods and find a young tree adapted for a cane, but no one will say that it was designed for a cane; and I once knew a very unskillful amateur carpenter, who was asked, at the close of a very industrious day's work, what he had made. He answered, "Well, I designed it to be a rustic chair, but I think it will answer nicely as a saw-buck." In this case the adaptation was certainly not the fruit of design.

But, even if design can be shown, it does not follow that the adaptation is the fruit of direct creative interposition; and the fact that it is not always perfect—that, perfect as the wing is in most birds, more than one species has become extinct in recent times, on account of the rudimentary and useless state of the wings—has been held by many to be sufficient proof that the adaptation was not produced in this way.

We shall be able to take a more fair view of this question after we have examined the ultimate nature—the homology, as it is called—of the organs of flight.

Feathers evidently take the place occupied by hair in mammals; and, in some birds which do not fly—such as the ostrich—they are very like hair; and examination of the microscopic structure and mode of growth of a feather shows that it is formed in the same way

with hair, claws, or finger-nails, and is only modified skin. When a section through a piece of skin is examined with the aid of a moderately-powerful microscope, the lower or internal surface is seen to be made up of little, irregularly-rounded cells, or bags, with soft semi-fluid contents; and, while the animal is alive, new cells are constantly forming under the old ones, which are pushed outward and crowded together, and gradually lose their soft contents, and are flattened out into very small scales. The outer layer of the skin is made up of

FIG. 3.

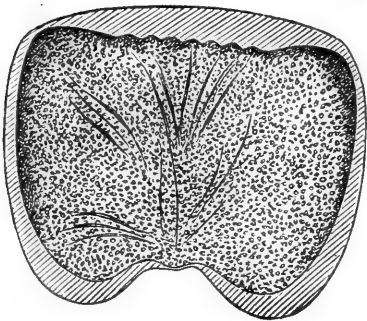

TRANSVERSE SECTION OF SHAFT OF PRIMARY WING-FEATHER OF A GOOSE, magnified to show the cellular structure.

FIG. 4.

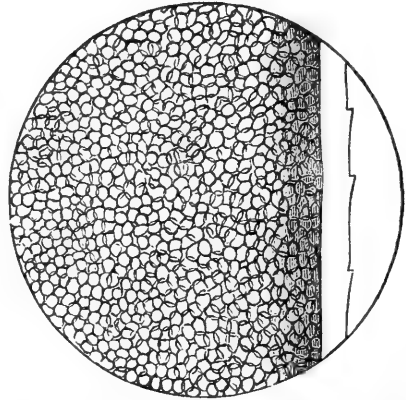

LONGITUDINAL SECTION OF SAME, more magnified.

these scales, which are fastened to each other firmly enough to be separated from the living layer below in a thin sheet, as happens when a blister is raised on the hand by unusual work, but in most parts of the body they are slowly rubbed off as new ones grow; but at the tips of the fingers they are so firmly united that they form horny plates, or "nails," which are pushed forward as new cells form at the root.

In the skin of a bird where a new feather is to grow there is a little pit, and, at the bottom of this, an elevation or pyramid; extending up one side of this pyramid is a groove, or furrow, deepest at the base, and gradually growing shallower until it disappears near the top; from each side of this furrow a great many smaller grooves extend around to the other side of the pyramid, and these also decrease in depth, and at last disappear just as they are about to meet on the side opposite the large furrow. The whole pyramid is covered with skin, and the surface is made of the same scales, or flattened cells, that are found over the rest of the surface of the body; but, instead of falling off when they are pushed out by the new ones below them, they become united or welded to each other, so as to form a horny coat over the surface of the pyramid, with ridges on its lower or inner surface, corresponding to the grooves on the pyramid; and, as new cells grow at the base, this coat or cast of the surface is pushed upward till it breaks at its thinnest part, which is, of course, the smooth part without ridges opposite the large furrow; and then, as it is



pushed outward and flattened, it assumes the form of a feather, the ridge formed in the main furrow being the shaft, while the casts of the side grooves form the separate barbs of the vane. When all of the vane has been formed and pushed forward, the pyramid loses its grooves and becomes smooth, and the wall now formed on its surface, being of the same thickness in all parts, does not break, but remains tubular and forms the quill, which is attached to what is left of the pyramid. A finger-nail or a hair is formed from the same kind of scales in the same way, the process differing only in those features which give to each organ its special character. Feathers, scales, hair, claws, and nails, all are made alike from the dead, flattened cells crowded to the surface by the process of growth.

If, passing from the feather to the wing, we study that in the same way, we shall find that it is made, part for part, on the same plan as the arm of a man, the fore-leg of a horse, the fore-foot of a turtle or frog, and the fin of a fish; and, when these organs are compared in their earlier stages of growth, the resemblance is very perfect; and it is only as one becomes fitted for swimming, another for flying, another for running, and another for handling and feeling, that the differences between them begin to appear. Studying now the whole body of the bird in the same way, and comparing it with a mammal, as the horse; a reptile, as the turtle; a batrachian, as the frog and a fish—we find that all these animals are constructed on the same general plan, and here, also, the resemblance is stronger in the earlier life of the animals. We find, however, that they do not all resemble each other in the same degree, for the bird is more like the turtle than like any of the others, and, when full grown, it preserves some resemblance to reptiles; and there is an animal, found only in the fossil state, called the archiopteryx, which unites in itself many of the characteristics of birds, such as the possession of feathers, with other characteristics as unmistakably reptilian.

Such are the principal facts to be learned about the wing, and any explanation of its origin must account for them all; and the same or similar facts may be learned by studying almost any organ or animal.

To recapitulate: they are, first, the wonderful adaptation of all parts for their uses, rendered still more wonderful by the second fact, that the parts so adapted are modified forms of what are called homologous organs, that is, organs having the same plan, but adapted to quite different uses, and having very little superficial resemblance; third, the fact that, when the growth of these homologous parts is compared, it is found that in their earlier stages they are very much alike, and differ so far as and at the same time that they acquire those characteristics that fit them for their special uses; fourth, is the fact that there are or have been animals whose structure has been so little modified that they seem to connect animals of very different but homologous structure.

Now, what is the meaning of these relations between organs and between animals? For that they have a meaning must be clear to all, and it is fair to presume that it is one that can be discovered by investigation.

The fact that two or many different animals are constructed on the same plan seems to indicate some kind of connection between the animals themselves, and it is the work of the zoologist to find what it is that thus connects them.

FIG. 5.

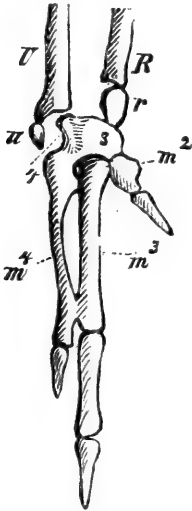

FORE-FOOT, OR "WING," OF EMBRYO YELLOW WARBLER.—(From Morse.) The hand in a Reptile and Embryo Bird compared. *U*, ulna; *R*, radius; *u*, ulnare, or cuneiform bone; *r*, radiale, or scaphoid bone; *c*, centrale. 1, 2, 3, 4, 5, first, second, third, fourth, and fifth carpals, *m*<sup>1</sup>, *m*<sup>2</sup>, *m*<sup>3</sup>, *m*<sup>4</sup>, *m*<sup>5</sup>, corresponding metacarpals.

FIG. 6.

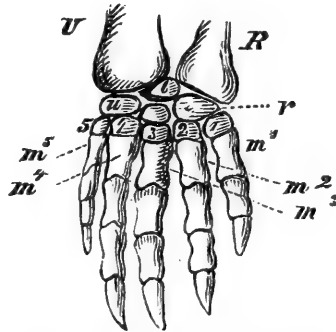

FORE-FOOT, OR "PADDLE," OF SNAPPING-TURTLE.—(From Gegenbauer.)

Two theories have been proposed, each of which seems to meet most of the points to be explained, but each seems to fail in some respects. One of these is, that the connection between different groups of animals is to be found only in the mind of their Creator; the other is, that there is a direct genetic connection or relationship between them.

Each of these theories is conceivable and worthy of consideration, for we can find examples of the building up of systems somewhat resembling the animal kingdom in each of these ways. The various kinds of steam-engines, for instance, are adapted each to its special work, with an accuracy rivaling that of Nature, yet all of them can be shown to be constructed on substantially the same plan.

If we trace the history of any form, such as the steep-grade locomotive, we find, as we go backward, that it loses, one by one, all of its special adaptations, until at last it is only a common locomotive at up-hill work. Tracing the history of the locomotive in the same way, we find that its special adaptations disappear, until it is nothing

but a power-engine placed on wheels—not the improved power-engine of the present day, but an unimproved and rudimentary form. We might trace the history of other forms in the same way, until we had found the one source for them all.

In this case there can be no genetic connection; each engine is an independent thing, and the only connection is an ideal one in the minds of the inventors; that is, the idea of the steam-engine has gone through a process of evolution, expansion, and perfection, and most of the steps in the process have been embodied in real engines, so that together they form a manifestation or record of the changes that the idea has undergone.

According to the theory of which Agassiz is the most celebrated advocate, the phenomena of life are to be explained in a somewhat similar way. Recognizing all the facts which seem to indicate the evolution of the animal kingdom, and being himself the discoverer of very many of them, he says that the evolution is simply the evolution of an idea in the mind of the Creator, which idea has been embodied in material form in such a way that it can be traced by the study of the animals that form its expression.

The other theory may also be illustrated by an example: When we compare languages which philologists tell us have descended from one parent tongue, we are attracted by their differences only, and it needs careful study and comparison to understand the similarity of plan which underlies them all; but when their history is traced it is seen that they were originally the same, and have become different as the races using them have become more widely separated, and, coming under new and widely different physical conditions, have diverged in their habits, feelings, thoughts, and associations, and have required different forms of speech to supply their need. Here, unlike the case of the steam-engines, the language has been the same all the time, and, although men have been the means by which the change has been effected, they have not been the intelligent cause, but have been unconsciously acted upon by agencies around them.

According to the theory with which Darwin is identified, although he is not by any means the author, but has simply removed some of the most serious objections, all the different forms of life have been evolved from one source in substantially the same way that languages have originated; as animals become exposed to new conditions, new varieties adapted to these conditions arise, and, as animals thus grow different, the parent unimproved forms are unable to struggle with their more perfect descendants and become extinct, so that the animals which would connect dissimilar forms are no longer in existence.

The evidence necessary for the perfect establishment of either of these theories does not seem to have been obtained as yet, and we can only decide provisionally, according to probabilities; but the discus-

sion of the evidence already collected, or even a bare outline of it, would lead us far beyond the limits of this article, which is simply designed to show how much food for study even a feather will supply, and what broad questions it will lead us into.



## WHAT THE CHEMISTRY OF THE ROCKS TEACHES.

BY C. C. MERRIMAN.

IT is a general rule that substances can crystallize only while solidifying from the liquid state of either fusion or solution. The only exceptions are, that some few substances crystallize directly from their vapors without passing through the intermediate liquid form. Now, the older unstratified rocks of the geological formations, as the granites, are unquestionably fusible, are crystalline in their structure, and are practically insoluble. Therefore the evidence is conclusive that they were all at one time in a molten, fluid state.

Thus far, it would appear, geologists are agreed, since they have named these formations the igneous rocks. But, whether the melted minerals were ever heated to a higher degree than fusion—that is, to the condition of vaporized elements—is an inquiry either carefully avoided by the authorities in geology, or merely mentioned as pertaining to an ingenious hypothesis which, it is claimed, is unsustained by any sufficient proof. It remains to be seen, however, if this theory of the original gaseous form of the material elements does not follow as a necessary consequence from the chemical constitution of the rocks themselves; and if it does not explain and bear testimony in geological and cosmical sciences to such an extent as to make it absolutely essential to them.

The question here presented resolves itself into two alternatives: Either the materials of the earth's crust were formed, according to chemical laws, out of the simple elements preëxisting in liquid or gaseous form, or they were created in the condition of melted and oxidized masses ready to cool into granite and limestone. The latter supposition will hardly be seriously entertained in these days of free inquiry into the natural causes of things. It is now not only conceded, but expected, that science shall have sole jurisdiction in every case where compound bodies are the subject of investigation. To follow them back to the primal laws and elements of their being—to reveal the cause and manner of their birth among the atoms—is now the highest aim of inductive research. On this border-line of inquiry, where the known shades off into the unknown, and the finite into the infinite, science has of late gained its most signal triumphs. And it scarcely requires a prophetic sense to discern that the groundwork of

all systems of scientific knowledge will soon be laid in molecular physics.

In the constituents of the solid earth we have forms and conditions of matter of remarkable composition and complexity. The original materials of the ground, of the rocks, and of the mines, are found to be, in every case, fully saturated chemical compounds. Many of them, as the silicates, are adamantine acids neutralized by alkaline bases harder than the flint. They could not be made more stable, inert, and solid. They are materials that have apparently gone through stupendous changes, activities, and combustions, and at last have settled down to a rest that knows no waking. Science has no duty more legitimate or more imperative than to inquire how these rock-masses came to be where they are, and in the condition they are.

In pursuing this inquiry—since we find one of the alternatives to be inadmissible—it is necessary, therefore, to accept the other, namely, that the matter which composes the geological formations preëxisted as simple elements, either in liquid or gaseous form. Oxygen, which makes up fully one-half the weight of the solid parts of the earth, is and always was a gas in its free state. In regard to the remaining elements that enter into their composition, such as silicon, aluminum, calcium, and sodium, they could not all have existed on the earth at the same time as melted liquids; for the same heat which held one in fusion would have evaporated others. Some, therefore, must have been contained in the atmosphere as simple gaseous elements. Inasmuch as granite is the base and substratum of all the other formations, if we show that this must originally have been in a gaseous state, we show that every other material must have been at the same time in like condition.

The granitic rocks are by far the most abundant terrestrial substance that we know of. Geologists assign to them a depth of not less than thirty miles. And still below them there is the same or nearly the same chemical substance in fusion, as the fact and analysis of volcanic products sufficiently prove. The compound which is in excess in all granite rocks is silica, the oxide of the element silicon. The varieties are formed chiefly by small percentages, more or less, of the oxides, alumina, and magnesia. This silica, or quartz, as well as the other components of the igneous rocks, is what has been termed "burnt material." It is the product of a most complete and tremendous conflagration; for the oxidation of silicon is as much and as powerful a combustion as the oxidation or burning of coal. To accomplish this burning, every particle of the silicon must have been brought into contact with oxygen gas. This would have been simply impossible if the mineral element had always been in a melted mass of miles in depth; for this, if for no other reason, that the oxygen could not get at it—certainly not, if it was covered by other solid or liquid substances. Or, if it were conceded that silicon ever formed the sur-

face of the earth, then all other materials of what is now the crust must have been gases above it; and, as nine-tenths of the elements in vapor are heavier than oxygen—many of them more than ten times as heavy—this gas could never have even touched this imaginary sea of silicon. The oxidation, then, was only possible in the regions of the atmosphere where oxygen existed and abounded. There only among the free-moving gases could the incalculable amount of heat evolved in the combination be carried off.

We confidently assume, therefore, that the whole of this most abundant mineral element once existed in the atmosphere in the form of a high-heated gas; and that some time and somewhere, on the confines of the enormously-extended sphere of vapors, there was found a current sufficiently cool to condense a portion of it. If the vapor of silicon follows the general rule—that the density of gases is in proportion to their atomic weights—then it was but a fraction heavier than oxygen, and therefore not far below it in the atmospheric strata. The unceasing commotion of the elements would soon have brought this first cloud-mist of silicon into contact with oxygen, to which it has a strong affinity under high heat. Oxidized, and in molten drops of silica, or crystals of quartz, this new-formed material commenced its descent toward the centre of gravity—the first creation from the primordial elements. As it fell into the more heated regions below, it was probably soon evaporated, and, the vapor rising, carried up with it the heat taken up in the evaporation. It was again condensed, its heat given up, and it descended for another charge of the internal fires. This, in all probability, is the epitome of the process of world-cooling.

At last, the showers of melted silex reached the liquid surface of the nucleus, which the force of gravity and compression must have formed, at an early period of the nebulous globe, of less or greater extent about its centre. From this period the increasing torrents of silica, intermingled with the silicates which were forming at the same time, poured down through the heavy vapors, and filled up the furlongs-deep of granite ocean. On this vast deposit, and at about this stage of the gradual cooling of the earth, began, we must suppose, the first hardening and crusting over of the surface, since at this point, near the close of the granite age, first commences the division of the earth's crust into varieties and layers more or less distinct, as also the upbearing of the heavy metals which, without this surface-hardening, could never have floated on any molten sea of minerals. The slow cooling of the granite masses beneath this crust and under the enormous atmospheric or other superincumbent pressure, conformed them to all the acknowledged conditions of the formation of the igneous rocks.

There is found in the different beds of the granitic rocks every proportion of the admixture of silica with the silicates of alumina.



It is as if chances as variable as winds and storms had regulated the production and mixture. There is every gradation in the texture of granite, from the fine-grained blocks of the quarry to the coarse, compacted breccia so common among boulders. It is as if the deeper beds had slowly cooled under great compression and consequent immobility of the particles, while the superficial layers had been worked up and conglomerated at the surface. There are specimens of granite composed of massive angular crystals, that seem as if they had been thrown together and cemented. It is, again, as if they were the congealed *débris* of some terrific hail-storm of quartz, mica, and feldspar.

After the greater part of the silicious minerals had been deposited, and the cooler exterior gases had thus been let down to a nearer vicinity with the heavier vapors, we find that the metals proper began gradually to condense and fall. Those which have no active affinities for the other elements were deposited in their native purity. Others took on the forms of oxides or sulphurets, according to their first exposures or strongest attractions. Among the first of these cloud-productions, the rock records tell us, were the scanty rainfalls of gold and platinum, and the more plentiful showers of silver and copper. Rivulets of native ores ran along the hardening crust, filling the veins and crevices, or mingling with the liquid quartz that was seaming the granite and gneiss.

Then from clouds of condensing iron vapor, that must have burned and scintillated with indescribable magnificence, fell the thick heavy storms of the black lodestone, the blood-red hematite, or the dark-yellow pyrites. Possibly storm-centres were established, over which the cyclones were held concentrated, and often repeated by force of intense magnetic attractions which have left their traces in almost every iron-mine.

Following these, at times and places, came on the great snow-storms of the waxy flakes of zinc-blende, and the pearly calamine, the red oxide or the white carbonate of lead, and the gray galena, the beautiful crystals of the tin-stone, the gray plumes of antimony, and all the tinted and varied forms of the less abundant ores and alloys. Meanwhile, through all the long ages of these metallic precipitations, there was continually falling over all the earth the white, impalpable powder of lime—the element calcium condensed into cloud-mist, and oxidized in the upper regions of the air.

These were the great chemical periods of our world; when the cooling vapors of the swollen sphere were struggling to unite and hold fast the embrace against the antagonist force of heat; when the conjoined elements were pouring down their fiery torrents, and the air was laden with the falling cinders and ashes of aerial conflagrations; when the vast workshop of Nature was forming and sorting its raw materials.

We do not, however, wish to be understood as insisting that all

these minerals and metals came down in just the form and order that we have indicated, or that they were regularly deposited, and left the orderly traces that perhaps our hasty sketch would seem to imply. There were unquestionably constant and profound commotions in the atmosphere, and the commingling of the most diverse elements. There were doubtless repeated meltings and chemical recombinations at the surface, and the rending and comminuting of the newly-formed crust by internal forces. The history of the earth's irregularities and disorders forms the greater part of geology. But what we do claim as certain is, that all the constituents of the outer shell of our globe existed at one time as elemental gases above a sea of matter that was held in condensation by superincumbent pressure; that, as the earth gradually cooled, these gases condensed somewhat in the order, inversely of their volatility, and directly of their nearness to the outer bounds of the atmosphere, and fell to the surface like rain and snow from water-clouds; that they formed chemical combinations at the instant of their condensation, or subsequently according to the power of their affinities or the elements that were present; and that, excepting the more recent displacements by mechanical forces, they now lie in the earth as they fell from the heavens.

The silica and silicates, which form the base, and by far the greater part of the earth's crust, became oxides of their several elements because oxygen was the superabundant gas in its composition. There have been worlds made up apparently without oxygen; for the meteorites, which must be regarded as sample specimens from some stranger world, however they may have been dispatched to us, are mostly composed of pure crystalline and malleable iron, which could have cooled into that condition only where there was no oxygen nor carbonic gases. If chlorine had been our superabundant gas, the silicon would perhaps quite as readily have united with it, and formed as stable a compound as with oxygen. But the product, instead of being the hardest of rocks, would have been a liquid very much resembling water, a little heavier, and nearly as volatile, as the common ethers. In this case there could have been no dry land, and no living beings that we can conceive of. Eternal clouds and storms would have covered the face of a surging boundless ocean.

Hitherto, in our accounts of terrestrial phenomena, water has played no part. It is probable that it was early formed, and in the condition of vapor or steam diffused through the upper air. In this state it bears the highest degree of heat that we can produce, without decomposition. Hydrogen is the lightest of all the gases, and unquestionably took its place on the outer limits of the atmosphere. There it was brought into contact with oxygen by the commotion of the elements, and converted into steam as fast as its lowering temperature allowed of the combination. As we might expect from the respective positions of the gases, all the hydrogen which fell to the

portion of the earth in the making up of its constituents was transformed into water-vapor. Hydrogen is found in no other combination that cannot be traced directly or indirectly to the decomposition of water.

The aqueous vapor being thus formed, and lying in the upper and cooler regions of the air, it began after a time to condense and fall toward the earth. Meeting with warmer strata as it descended, it was soon evaporated and sent up with a load of heat that was set free again by a recondensation. Then another and perhaps lower descent for another charge of heat. Thus, on the outskirts of the air, water-vapor was coöperating in the work of the heavier vapors of the interior. It was the great fire-carrier of the globe during all the time of the contraction and consolidation of the lower elements. When every thing else that was condensable had turned to dust and ashes, and fallen to the earth, at last the waters reached the parched and scorious surface, and commenced that grand series of aqueous transformations which made a new earth for the indwelling of life.

In the first place, it was necessary that the upper crust should be hydrated, precisely as lime is slaked by pouring water on it. The material which had been last deposited was in reality this same caustic lime. In its lower deposits it was gradually intermixed with the silicious compounds, until these formed the masses which are now the unstratified granitic rocks. As every one knows, the slaking of quick-lime absorbs a large quantity of water, which is incorporated into the solid, and great heat is evolved with enlargement of bulk. The pure silicious rocks do not take up water in this way, being what is termed anhydrous. All the rock-materials, then, that lie above the granite must, at some time, have undergone this hydrating, reheating, and swelling process. We accordingly find that all those strata which have remained in their original position, such as the gneiss, the mica schists, the clay-slates, and the primary limestones, have the appearance of having been subjected to great heat and pressure, after having been acted upon by water and steam. In some instances they have been partially melted, in others strangely contorted, and in others partly dissolved. Under certain circumstances, hot water and steam will dissolve small portions of silica, and, if charged with carbonic-acid gas, will dissolve lime quite freely.

The rainfalls of the primeval ages must have been fully saturated with this oxide of carbon, which has played such an important part in the making up of the strata. In this form it carbonated all the limestones, carried all the building-materials to the shell and coral land-makers, and furnished the supplies for the immense magazines of the hydro-carbons. And, after all this, there was enough carbonic-acid gas left in the air for the enormous vegetation of the coal-beds. But it was necessary that the carbon of this gas should be laid away in the earth in some form, either burnt or unburnt, before air-breathing

life could come to any perfection. The solidifying of the carbonic oxide was the latest and the slowest of the atmospheric changes.

It appears that during the epoch of the hydration of the lime-rocks there occurred periods when the waters were gathered into seas, and were sufficiently cooled for the existence of marine infusoria, mollusks, and corals. Life, in some form, has ever been ready to spring into being the moment that conditions and surroundings were suitable for it. After the deposition, in those temporary oceans, of considerable thicknesses of Cambrian or Silurian strata, mixed with organic remains, some rent or upheaval has let the waters down to new beds of unslaked material, which have heated, and, as it is termed, metamorphosed those first fossiliferous deposits.

The subsequent changes which the earth's crust has undergone—aqueous, volcanic, and organic—the working up of the conglomerates and sandstones, the depositing of the deep-sea beds, the overflowing of the traps and lavas, the storing away of the carboniferous treasures, are all the story of every hand-book of geology, and pertain no more to one theory than another of the origin of the rocks. When the quarries were once made and opened, the after-work was merely mechanics and masonry.

We have heretofore assumed that the gases which originally composed the aërial envelope of the earth took up separate positions therein, according to their specific gravities. This might seem to be controverted by experiments on the diffusion of gases, in which those of very different weights, as chlorine and hydrogen, will intimately commingle, even against gravity, when brought into contact. This may be true in the narrow compass of a laboratory experiment, and yet not apply to any considerable thicknesses of the gases. Such a diffusion, of one mile in depth of chlorine, would be equal to lifting up to the hydrogen a shell of solid iron two feet thick. Whether we explain the distinguishing principle of the constitution of gases as a mutual repulsion of their molecules, or, according to a late theory, as an incessant motion and clashing of atoms, there is nothing in either to warrant the supposition of the lifting or overcoming any considerable weight in the diffusion of gases. Under the first theory, diffusion, to a limited extent, would be accounted for by the small residuum of chemical or cohesive attraction that would remain between the atoms when separated as they are in gases; and, under the last theory, by the mechanical impulsion of the molecules, through their hitting against each other. Evidently, it is a principle which operates only within narrow limits, and in the lower temperatures of the gases. The sun gives no indications of such a commingling of its gaseous elements. Spectrum analysis, when applied to its outer edges, shows first hydrogen, then the vapors of sodium and magnesium, and, lastly, those of calcium and iron. The same fact and order of position are found to exist in the more condensed layers of the sun-spots.

We have also further assumed that the elements, in their gaseous states, have specific gravities corresponding to their atomic weights. It is well known that all gases, whether simple or compound, at the same temperature and pressure, and not near to a condensing point or other change of state, contain precisely the same number of molecules in the same volume. Therefore, it necessarily results that the same measures of the different gases should have weights corresponding to the weights of the molecules of which they are composed. Thus the atom of oxygen is sixteen times as heavy as that of hydrogen; therefore a cubic foot of oxygen gas will weigh sixteen times as much as a cubic foot of hydrogen gas. This is found to be experimentally true of all the gases that can be measured and weighed. The apparent but not real exceptions are that in arsenic and phosphorus two atoms of the element unite to form one molecule of the gas, thus making it twice as heavy as it would be, according to the general rule; while, in the case of mercury and cadmium, the atom divides into two in forming their vapors. Hence we are not absolutely sure in regard to the vapor-molecule, and therefore vapor-density, of such elements as carbon, silicon, and calcium, which chemists have not been able to volatilize. But there is every probability, both from analogy and the position in which some of them are found in the photosphere of the sun, that the vapors of nearly all of them correspond strictly to their combining numbers. The following table, therefore, will show the relative positions, in the atmospheric strata, of some of the most important elements, with the weights of their atoms in hydrogen units, their vapor-densities, compared with air, and the solid specific gravities of some of them as compared with water :

GASES.	Atomic Weights. H = 1.	Sp. gr. of Gas. H = 1.	Sp. gr. of Solid. Water = 1.
Hydrogen.....	1	.069	....
Carbon.....	12	.828	2.09
Nitrogen.....	14	.972	....
Oxygen.....	16	1.105	....
Sodium.....	23	1.59	.98
Magnesium.....	24	1.66	1.74
Aluminum.....	27.5	1.90	2.60
Silicon.....	28.5	1.97	2.40
Sulphur.....	32	2.22	2.
Chlorine.....	35.5	2.44	1.33
Potassium.....	39	2.69	.86
Calcium.....	40	2.76	1.58
Iron.....	56	3.86	7.80
Copper.....	63.5	4.39	8.96
Mercury.....	200÷2	6.97	13.60
Silver.....	108	7.47	10.53
Gold.....	196.5	13.57	19.34
Platinum.....	198	13.66	21.50

It will be noticed from this table that the elements were arranged in positions most suitable for their combination and deposition, both in the geological order, and in the probable order of their condensa-

tion from vapors. Oxygen and silicon, which doubtless composed more than four-fifths of the entire bulk of the gases, were separated from each other only by the elements that were needed to make up the silicates. Their compound, silica, is involatile, and even infusible by itself, under any degree of heat that we can command. The same is true of lime and the earlier-formed silicates. Therefore it is impossible to decide from their volatility which of these substances would have first condensed and reached the surface. But, as the vapor of silica, when formed, would still be of nearly the same specific gravity with silicon (2.07), and would still separate by its immense volume the oxygen from the calcium below, we may suppose that in any case silica would have to be condensed and deposited, in greater part at least, before lime, the oxide of calcium, could be formed.

Along with silica were formed and deposited the silicates of alumina—mica and feldspar; then the partially fusible silicates of magnesia, lime, and iron—hornblende, augite, and talc. There followed a numerous order of complex silicates, in which the above-named ingredients are varied by small proportions of manganese, soda, strontia, zirconia, and many other mineral bases. With, and after these, was produced the lime-deposit, the last of the minerals. The metallic vapors, which were all heavier than the mineral, were condensed and deposited chiefly during the later silicate period, and somewhat in the inverse order of their volatility, but locally and irregularly as results of great perturbations, or storms in the air.

It will further be seen, from the last column of the table, that in no respect are the materials of the earth deposited according to their specific gravities as solids or liquids. There is, in the superincumbent rock and ore masses, no order of position that would indicate in the least the floating or buoyancy of the lighter substances. Therefore, their arrangement cannot be referred to any origin from liquid conditions; and the only other theory is that of their gaseous origin.

There are many apparent anomalies in the deposition of the metallic and mineral compounds, which may require much study, and perhaps further knowledge and experiment for their explanation. Thus there is in one place a carbonate of lime—marble—and in another a sulphate of lime—gypsum. There are in certain localities sulphuret-ores of iron or copper, and in others oxide-ores; while the metals of greatest vapor-density, as mercury, lead, bismuth, and antimony, are found almost exclusively in sulphuret-ores. It will perhaps eventually be established that sulphur was combined wholly into sulphuric-acid gas, as carbon was formed entirely into carbonic-acid gas; that both were brought to the surface of the earth in solution with rain-water; and that sulphur in this form united with the metals which had failed to be oxidized upon their condensation in the air, and sulphated the quick-lime in the earth, which had not been carbonated by the carbonic solution. Then there is the exceptional production in Nature



of the chloride of sodium—common salt. Apparently in this one instance the oxide is the less stable compound.

But if, as we have endeavored to prove, there is a necessity of accounting, in accordance with this theory, for the various compounds and phenomena with which geology makes us familiar, then it is in the highest degree essential that experiment and research be prosecuted in this new field. And there must be no hesitation in accepting the conclusions to which they lead. Should the nebulous origin of one planet be thus established by internal and inductive evidence, then the nebular theory of the formation of worlds, which has heretofore been received as only a provisional hypothesis, must be accepted as having a scientific basis. If the earth has once been a self-luminous body, in all respects excepting size, like the sun of to-day, it follows from analogy that the other planets have likewise been minor suns which have become extinguished by the burning out of their materials. To an observer on any unseen world among the stars, our sun should have appeared in those times as a brilliant double, or multiple star, around which nine lesser companions have shone out for a season, and then one after the other folded themselves up in darkness.

Furthermore, the study of this subject may throw light on many cosmical problems—may tell us in earth-periods, if not in years, how old the sun is when his glowing vapors begin to condense into dark clouds; and perhaps, too, something of his future prospects as a luminary. It is remarkable that the spectrum has never shown any indications of free oxygen in the atmosphere of the sun. Is not the absence of this element further corroborated by the fact that the solar spots, which there is evidence to believe are condensing clouds of iron and calcium, do not glow with fierce burning, as they would if oxygen were present? Does not the enormous volume of the sun's uncombined hydrogen indicate that it has not found, then, the element of its strongest affinity? And is there not reason to believe that the heat and light supplies of our great luminary will last all the longer for the absence of this most extravagant fire-generator?

Again, the four outer planets of our system have specific gravities varying but little from that of water. Considering central condensation from pressure, it is probable that they are not so dense as they would be if composed of the lightest compound substance that we know of. If oxygen had been there in excess, it would long ago have burned and condensed their elements, whatever they might be, into most stable and solid forms. This gas, therefore, cannot have formed any considerable part of their constitution. Is it not, then, a probable supposition that these distant planets are composed of some non-combining and inactive elements like nitrogen, and that, undisturbed by combustions or elemental agitations, they have quietly stratified into gaseous worlds, retaining in great part their original heat? So far

as the spectroscope gives any indications of their constitution, it shows them to be composed of gases unknown in the earth.

As we have stated, the four outer planets are very nearly of the specific gravity of water; then come the innumerable asteroids, filling the place of a missing planet, and of which we know but little; then three planets that are five and a half times as dense as water; and lastly, Mercury, over eight times as dense. Does not this increasing density of the planets, from the outer to the inner, imply that they have become successively formed on the exterior of one great parent globe, and received each its portion, in the main, of denser elements, as it was later born? That this effect should appear somewhat in groups of the planets, is owing, probably, to the absence or excess of oxygen among their components.

But, if this is so, what shall we say of hydrogen, the lightest of all the gases, which seems to be most abundant the nearer to the centre of the system? To explain this notable exception, might we conjecture that hydrogen is a more recent production than the worlds themselves? It has been observed time and again to burst up from the nethermost regions of the sun with inconceivable force, as if it were the pent-up product of a volcano, and to throw up columns of its flaming gas, in one case 200,000 miles high. And these great outbursts of hydrogen are always the precursors of the dark, sunken spots in the photosphere. How came this almost imponderable ether to be imprisoned in the deep craters of the sun, if it is not a product that is constantly forming in the solar caldron?

But it is easier to ask questions than to answer them. And I will close, in the fear of having been already thought too free with the scientific imagination.



## THE UNITED STATES NAVAL OBSERVATORY.

BY EMMA M. CONVERSE.

THE importance of establishing a first meridian for the United States at the seat of government, in connection with a National Observatory for the purpose of systematic scientific observation, attracted the attention of Congress as early as 1810. In 1813 the report of the committee, to whom the matter had been intrusted, was read before the House by one of its prominent members. But such were the disturbed condition of the country, and the absorbing interest in its military affairs during the war with Great Britain, that the subject was not again revived till 1815, when the original memorial with the several reports, hitherto presented, and the letter of the Secretary of State, read before the House in 1813, were referred to a select committee. This committee strongly advocated in its report the erection

of a National Observatory, furnished with suitable instruments and apparatus for astronomical observation, and that the President should cause such observations to be made as would determine the longitude of the Capitol with the greatest practicable degree of exactness.

But no steps were taken at that time to carry out the resolution, and the subject was not again referred to till 1818. A third memorial was then presented, soliciting not the erection of an observatory, but simply that additional observations be made to test the accuracy of results already obtained, in order to insure a correct determination of our longitude from Greenwich. Nearly three years of tedious delay were required before the requisite resolution was passed which insured the modest commencement of what is destined to become one of the great scientific institutions of the country, and, we trust, of the civilized world.

In 1821 Mr. Lambert, the original memorialist, was appointed by the President "to make astronomical observations by lunar occultations of fixed stars, solar eclipses, or any approved method adapted to ascertain the longitude of the Capitol from Greenwich." In 1823, President Monroe submitted to Congress Mr. Lambert's final report, in which he stated that by the diligent use of such instruments for his work, as the country afforded, by the employment of different methods, and by the assistance of competent persons in various sections of the United States to test the accuracy of his work, he had endeavored to fulfill his commission to the extent of his ability. He gave, as the mean result, the longitude of the Capitol  $76^{\circ} 55' 30'' 54$  west from Greenwich. Thus the first step in the establishment of an observatory was taken in determining the longitude of the Capitol; for, without such an institution furnished with suitable instruments and apparatus, no accurate measurements of the positions of the heavenly bodies could be made, and the computation of a nautical almanac or astronomical ephemeris would be impossible.

The next movement that was made toward the accomplishment of the object was in 1825, when President Adams, in his first message, urged upon Congress the establishment of a National University. Connected with this, he earnestly recommended the erection of an astronomical observatory, to watch the phenomena of the heavens, and to give periodical publications of observations. The matter was referred to a select committee, who presented an elaborate report in 1826, accompanied by a bill to establish an observatory in the District of Columbia. Although the location, cost of the edifice, and the expense of carrying it on, were freely discussed, no action was taken in the matter; and Mr. Adams's recommendation, though associated with the progress of the nation, and independent of party or personal interest, was allowed to lie unnoticed.

But, after years of neglect and indifference on the part of Congress, a few officers of the navy had the honor of taking the first direct ac-

tion in the creation of the institution. In 1830 the Depot of Charts and Instruments for the Navy was established in Washington. This was accomplished under the orders of the Navy Commissioners, and with the sanction of the Secretary of the Navy. Lieutenant Goldsborough, through whose influence principally the bureau was created, was intrusted with the charge of it. He collected from New York and other places the chronometers, sextants, theodolites, and other instruments and charts of the navy, and located them in a building opposite the residence of the Attorney-General, Hon. William Wirt. A transit instrument was afterward added, and the naval Depot of Charts and Instruments was in working order. One duty of the officers was the careful rating of all chronometers belonging to the navy, which was at first effected by sextant and circle observations; but afterward with a thirty-inch transit instrument. This transit was mounted within a small circular building upon a brick pier having a base twenty feet below the surface, and is noteworthy as the first astronomical instrument erected for the navy at Washington.

In 1833 Lieutenant Wilkes succeeded to the charge of the depot, and obtained permission to remove the office to Capitol Hill, where it remained until 1842. He erected here at his own expense an observatory sixteen feet square, and mounted a five-foot transit. But no regular observations were made till 1838, on the departure of the exploring expedition, the principal use made of the transit being the determination of time. In 1837 Lieutenant Gilliss was left in charge of the depot, and, during the absence of the exploring expedition, and in connection with it, made invaluable observations on moon culminations, occultations, and eclipses. There was not a visible culmination of the moon, occurring when the sun was an hour above the horizon, from 1838 to 1842, nor an occultation after the 15th of June, 1839, with one exception, which he did not personally observe. He also completed an important series of magnetic and meteorological observations.

As the work took on larger proportions under such devoted leadership, and valuable and expensive instruments were added, the unsuitableness of the building, the defects of the transit-instrument, and the want of space to erect a permanent circle, became more evident. Earnest solicitations were made for an appropriation for a permanent establishment, and the subject was brought before Congress by the Secretary of the Navy in 1841. Tedious and disheartening delay occurred before Congress was roused to an appreciation of the importance of the enterprise. But, after persistent effort on the part of its supporters, at the last hour of the session of 1841-'42 a bill passed both Houses without discussion, authorizing the Navy authorities to contract for the building of a suitable institution, and that it should be located on any unappropriated land in the District of Columbia which the President deemed suitable. Thus was the future observatory officially recognized.

All obstacles to further progress being happily overcome, plans for erecting a Naval Observatory under the best available conditions were speedily made matter for diligent study. Visits were made to the Northern cities to obtain assistance, distinguished astronomers were consulted, and an accomplished architect secured to draught plans, the whole care being intrusted to Lieutenant Gilliss. The locality chosen for the observatory possesses an historic interest. The site assigned to it was known as "Reservation No. 4," on the original plan of the city. It lies on the north bank of the Potomac, in the southwestern part of the city. When General Braddock marched against Fort Duquesne in the colonial wars, his troops landed and encamped on this hill. Washington's letters show that he crossed at this point from Alexandria to join Braddock at Frederick. A large rock within the grounds of the observatory is pointed out as the spot on which these landings were made. It was here that the first President proposed to locate a national university, and at a later date it was suggested by President John Quincy Adams for the site of an observatory. The base of the observatory is the second highest eminence within the city limits, and is on a level with the floor of the Congressional Library.

In 1843 Lieutenant Gilliss reported to the Navy Department the adoption of a plan for an observatory, and also the progress of the erection of a building in accordance with the plan. In 1844 the new building was ready for occupancy, and the instruments adjusted for the commencement of active work. The central building is about fifty feet square, raised on a firm foundation, and built of brick in the most thorough manner. It is two stories and a basement high, with a parapet and balustrade of wood around the top, and is surmounted by a revolving dome resting on a circular wall. The roof is nearly flat, and so arranged as to form a level promenade for gazing observations. On the east and west sides of the building are wings, and also on the south. In 1870, an observing-room for the transit-circle was added, forming an extension of the west wing. A tower and dome, to accommodate the superb new equatorial telescope recently completed, was finished in October. The equipment of the observatory in astronomical, magnetic, and meteorological instruments is now in a fair way to become worthy of the institution and the country it represents, and the library is increasing rapidly in the number of volumes and their scientific value.

Among the influences that helped to bring about this auspicious result were, in the first place, the unswerving interest and indefatigable zeal of Mr. John Quincy Adams. Although his suggestions concerning the establishment of a national observatory were treated with neglect during the term of his presidency, he did not lessen his efforts in the cause dear to his heart. In 1838 he presented its claims before President Van Buren, and in 1842 in his place in the House of

Representatives. The report of the committee, presented at this session by Mr. Adams, should be read by every student of astronomy, for the fervor of its eloquence and the nobility of the truths it enunciates. Lieutenant Gilliss was equally unwearied in the cause. It was by his diligent and successful observations that he secured the essential confidence and coöperation of the Navy Department, and of the naval committees. He was the first person, in the United States, who gave his whole time to practical astronomical work. He first published a volume of observations, prepared a catalogue of the stars, and planned and carried into effect the construction of a working observatory, in contrast with one intended simply to teach. For this arduous work he was specially gifted, possessing a wondrous acuteness of the perceptive powers of eye and ear. Prof. Peirce, after examining his observations from 1838 to 1842, gives him the second place in the long list of observers, living and dead, whose results were critically and searchingly tested by the so-called personal scale. Profs. Bartlett, Kendall, and Walker, contributed largely by their labors to the establishment of the institution. Their series of astronomical observations, their publications, and the able report on European observatories, by Prof. Bartlett, in 1840, had a powerful influence in rousing public interest in the subject, and, combining with other influences, produced the desired result.

In 1844 Commander Maury was appointed superintendent of the new observatory, assisted by the same officers who had been attached to the Depot of Charts. Under the instruction of the Secretary of the Navy, the most extensive astronomical work was proposed in cataloguing the stars. The task set before the infant observatory, said a critic in the *North American Review*, was "nothing less than assigning color, position, and magnitude, to every star in the heavens, which could be seen with the instruments." With the resources at the command of the officers at that time, it would have required a century to complete it. The work was, however, commenced of making a catalogue of the stars down to the ninth and tenth magnitude. In 1846 the first volume of observations was issued from the press. In 1847 the observatory was first brought into prominence by the identification of the newly-discovered planet Neptune, with a star of Lalande's catalogue of 1795. Astronomers thus obtained an observation of Neptune made fifty years before, which afforded the means of an accurate determination of its orbit; and the superintendent of the "American Nautical Almanac" was enabled to publish an ephemeris of the new planet two years in advance of all other parts of his almanac. In 1848 the institution first bore the name of "United States Naval Observatory" instead of "National," an honor justly due to the Navy Department which controlled it, and to the navy officers who had charge of its interests. But the preparation and publication of Wind and Current Charts absorbed the attention of the superintend-



ent. With the exception of the equatorial and mural circle-observations, zone-observations, and several years' unpublished work of other observers, regular astronomical work did not receive the prominent attention demanded for the best interests of the observatory. In 1861 Lieutenant Maury left his position to join the cause of the Confederate States of the South.

Captain Gilliss succeeded to the office in 1861. His heart and hand were in the work. He published the volume of observations for 1861 promptly in 1862. He gave detailed statements of the volumes of observations he found unprepared for the press, took measures for their publication, for the regular and prompt issue of annual volumes from the observatory, and arranged that meteorological observations should form a part of each volume. The volume of observations for 1862 contained a discussion concerning the longitude of Washington; a paper on Comet II., 1862, with drawings of the comet during the period of greatest brilliancy; and a plate illustrating the appearance of Mars, near the opposition in that year. The special work for 1863 was an investigation of the solar parallax from observations on the planet Mars. Nearly 11,000 observations were made with four instruments during this year. A transit-circle was also contracted for to improve the defective equipment of the observatory. But, while the field was widening before him, and when neither of his three favorite aims had come to a successful issue, Captain Gilliss was suddenly removed by death, in 1865, from the scene of his labors.

Rear-Admiral Davis was placed in charge of the observatory in 1865. During the same year the great transit-circle was completed, and placed in position in the then west wing of the observatory. This constituted an era in its history, and raised it to a more fitting rank among institutions of its class. The volumes of observations for 1863 and 1864 were published in 1865 and 1866. The meteorological observations from 1842 to 1867 were fully discussed, a report was made on interoceanic canals and railroads, and the regular routine work was diligently kept up. In 1867 Rear-Admiral Davis was ordered to take command of the South-Atlantic Squadron.

In 1867 Rear-Admiral Sands became the fourth superintendent, and is the present incumbent of the office. Since that time the work has so greatly increased in all directions, and the progress of science demands such an amount of labor, that the limits of this article will permit only a brief mention of a few of the most important portions of the work accomplished. One of the recent publications of the observatory is a "Manual of its Founding and Progress," prepared by Prof. Nourse. We refer readers, who desire more extended information, to this able and exhaustive paper, to which we are indebted for our facts and suggestive information. Under the present superintendent, and his efficient and coöperative assistants, the observatory has gone steadily forward, enlarging its boundaries, and widening its field

of vision. The current years have been rich in results in the regular work of the institution, as the published volumes of observations bear testimony. A new observing-room for the transit-circle was erected in the west wing, and the mounting of the circle was completed in 1870. The library was removed to the room previously occupied by it, and now numbers more than 5,000 bound volumes. The total solar eclipses of August 7, 1869, in America, and December 22, 1870, in Europe, were closely observed by parties from the observatory, and full reports of their observations were published.

But the greatest achievement toward raising the observatory to a higher rank among its peers was the successful completion and mounting, in the new tower and dome prepared for it, of the Great Equatorial, in the month of October of the past year. This auspicious event is largely owing to the persevering effort of the superintendent. After repeated representations concerning the necessity of the instrument, Congress made an appropriation of \$50,000 for the purpose. The contract was made in August, 1870, with Messrs. Alvan Clark & Sons, of Cambridgeport, Mass. They agreed to construct a refracting telescope, of good definition, and of 26 inches clear aperture, mounted equatorially on the German plan, and supplied with all the appliances that modern science has developed. They required four years to complete it. But the opticians were ahead of their contract, and the observatory is now rejoicing in the absolute possession of the talismanic instrument which has been the object of its ambition.

The future work of the institution will demand all its resources. It is already in the full tide of preparation for the observation of the coming transit of Venus in 1874, for which it has received an appropriation of \$150,000. It is looking forward to still more satisfactory results from the transit of 1882, which will be specially favorable for observation on American ground, while an opposition of Mars, in 1877, will test the power of its new possession.

With this grand telescope and its equipment, with a *personnel* made up of officers who honor their profession, with Congress ready to grant all needful aid, there is every reason to anticipate a future for the United States Naval Observatory, honorable to itself, and honorable to the country it represents.



## THE MANTIS, OR PRAYING INSECT.

**S**PECIES of insects known as Mantids belong to the order Orthoptera, which includes crickets, grasshoppers, cockroaches, locusts, etc. The following figure illustrates the appearance of one of these. They are of bright, variegated colors, and are sometimes quite large, even three or four inches in length. The mantis lays its eggs at the

end of summer, in rounded, fragile shells, which it attaches to the branches of trees, and which do not hatch till the following summer. It differs in locomotion from its orthopterous relatives, which travel by jumps, while the mantis crawls so slowly that its progress can only be appreciated by careful and prolonged watching. This trait is connected with another character by which the mantis differs from the foregoing groups, for, while they are vegetarians, this insect is carnivorous, and its insidious movements are part of the policy by which it

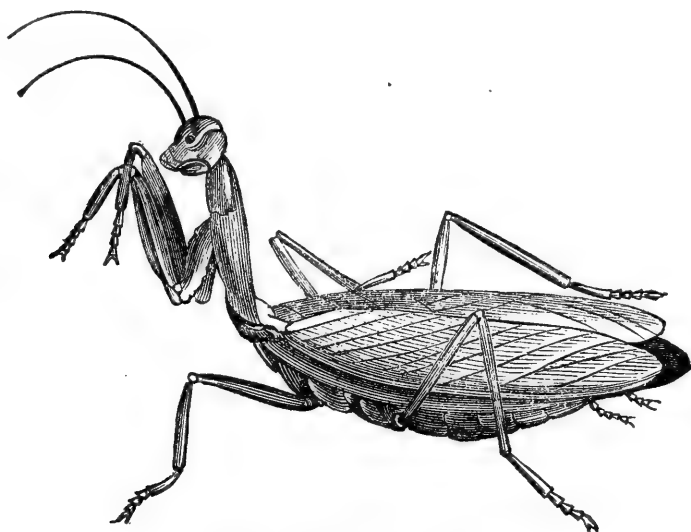

MANTIS RELIGIOSA (MALE).

captures the various creatures upon which it feeds. But the mantis is not only a carnivore which lives by killing and devouring other insects, it is also a creature of the most quarrelsome disposition; in fact, it is a ferocious cannibal. If two of these insects be shut up together, they engage in a desperate combat; they deal each other blows with their front legs, and do not leave off fighting until the stronger has succeeded in eating off the other's head. From their very birth the larvæ attack each other. In their contests, the male, being smaller than the female, is often the victim. This pugnacity of the mantis is the source of amusement to children in China. Two mantids are shut up together in a bamboo cage, and the young heathen view with delight the inevitable battle, and the resulting cannibal feast.

And yet, while its inoffensive orthopterous brethren have got but little credit for their virtues, and are generally reviled as nuisances, this atrocious little savage has had the fortune to acquire a peculiar reputation for wisdom and saintliness. For thousands of years, and in all parts of the world, it has borne this character. The cause has been that it habitually assumes an attitude that appears devotional, and it was supposed to spend a large portion of its life in prayer. Settled on the ground, it raises its head and thorax, clasps together the joints of its front legs (see cut), and raises them as if in supplication, and remains in this posture for hours together. To our illogical and superstitious

forefathers what could the upraised and crossed arms indicate but an attitude of devotion?

The name *mantis* (diviner) was given to this insect, it is said, by the Greeks, in accordance with the notion that, when the creature assumes its peculiar attitude of meditation, it is engaged in the contemplation of futurity. Naturalists have encouraged the superstition by giving names to the different species which imply some kind of sanctity; thus, we have *Mantis oratoria*, *Mantis religiosa*, *Mantis superstitiosa*, etc. With the French it is the *Prega-Dieu* (that prays to God), *Le Prêcheur* (the preacher); with the Germans it is *Gottesanbeterin* (worshiper of God), while the English-speaking nations have dubbed it the *Praying Insect*. The names familiarly given to it in Southern Europe are sufficiently expressive of the veneration with which it is regarded—nun, saint, suppliant, mendicant, etc. “In the eyes of the Languedoc peasants,” says Figuier, “the *Mantis religiosa* is held sacred, and they firmly believe that it performs its devotions.” Mr. Spicer, writing in *Science Gossip*, remarks: “Nor was this feeling of veneration confined to the nations of Europe. At the present day (and doubtless it was the same in old times also) a *Mantis* is an object of worship with certain tribes of North Africa.” Sparmann also tells us (“*Travels in Africa*”) that “in the southern part of the same continent it is venerated by the Hottentots; and that, should one of these insects chance to settle on an individual, he is looked upon in the light of a saint, and as specially favored by Heaven.”

That the superstition should have gone to greater lengths than mere inference was natural: somebody was certain to make the mantis open his mouth and give audible expression to his devout sentiments. Of course we should expect this in the middle ages, when credulity was unbounded, and there was a universal belief in the semi-divine nature of this wicked bug. “The great Saint Francis Xavier is said to have held a conversation with one which he came across in a forest, and to have induced it to chant a hymn!”

Dr. James Mann, author of the “*Guide to the Knowledge of Life*,” and who was for some years superintendent of education in the province of Natal, South Africa, has written a very interesting account of the insects of that region, which was published in the *Intellectual Observer*, and from that article we quote the following passage regarding the mantis, from which it will be seen that the insect still contrives to keep up its theological reputation: “Of orthopterous Natal insects, the large green mantis is certainly a distinguished chief. He is a very remarkable fellow, powerful alike upon wing and leg, but much given to fits of lethargy and brown study. His traditional religious exercise, indeed, is simply a lying in wait for what the gods may send in the way of food. He fixes himself, as if in rapt contemplation, upon some convenient stalk or leaf, and then bends up his chest and shoulders into an almost erect position, pressing together his arms in front,

and looking well out before him, with the palpi of his lips slightly vibrating. In this expectant mood he allows himself to be coaxed with the finger, merely staggering back a pace or two, and fixing his goggle-eyes upon the biped who vouchsafes this personal attention. If he lights upon a perpendicular window or wall when in this vein of 'religious' ecstasy, he seems to remain for hours together without motion, but all the while he mounts imperceptibly up and up until he reaches the ceiling or roof which limits the chamber in the upward direction. The closest watching does not show how this most gradual of all climbings is accomplished. Not a limb can be seen to move, yet up, minute after minute, he glides. It is while he is in these fits of expectant ecstasy that he seizes his prey. He is essentially a carnivorous feeder, and pounces stealthily upon any unwary insect that settles within convenient reach, seizing the victim between his upraised legs, and fixing it there between the row of spikelets with which these prehensile limbs are fringed. After a deliberate inspection of the morsel held in this position, he goes to work with his jaws. . . .

"It was the author's fate upon one auspicious occasion," writes Dr. Mann, "to watch one of these 'religious' insects engaged in a remarkably appropriate occupation. A dignitary of the Natal Church, who has since made some noise in the world (Bishop Colenso), was, one warm summer evening, with all the windows and doors of his chapel open to the refreshing breeze, preaching by candle-light, when a huge green mantis whizzed into the assembly and perched himself upon the preacher's white neckerchief; and, first folding his arms into the prayerful attitude, he raised his chest and shoulders into rapt attention, turning his goggles from side to side, and following responsively each motion of the spectacles, that glanced, now on this hand and now on that, from above. He remained fixed in this convenient position until properly dismissed with the rest of the congregation at the close of the sermon, and he did not even then depart at once, being puzzled and staggered, in all probability, by some of the novel doctrines he had been listening to."



## EVOLUTION AND THE ORIGIN OF LIFE.

By H. CHARLTON BASTIAN, M. D., F. R. S.

YEAR by year the word "Evolution" becomes diffused more widely through our literature, and the central idea which it implies grows familiar to an ever-increasing multitude of readers. We have witnessed within the last few years a marvelous awakening of interest in the minds of the public generally to questions of science, and it so happens that a discussion of the doctrine of Evolution has

been more or less directly involved in those departments of Science and Philosophy which have during this period received the largest share of popular attention.

Perhaps the greatest impetus was given to the spread of the doctrine about fourteen years ago, by the publication of Mr. Darwin's now celebrated "Origin of Species." This volume has been followed by quite a library of works and memoirs on the same subject—partly scientific and partly popular. From about the same date also, Mr. Herbert Spencer has been engaged in systematically elaborating the principles of an all-comprehensive Evolution Philosophy, and the results of his genius and labor are now undoubtedly influencing the thoughts of a rapidly-widening circle of readers. Both in this country and abroad, the doctrine of Evolution is gradually but surely gaining ground among the most reflective; and, although many other writers have been more or less influential in determining this result, it has been in the main brought about by the two above mentioned.

Evolution implies continuity and uniformity. It teaches us to look upon events of all kinds as the products of continuously-operating causes—it recognizes no sudden breaks or causeless stoppages in the sequence of natural phenomena. It equally implies that natural events do not vary spontaneously. It is a philosophy which deals with natural phenomena in their widest sense; it embraces both the present and the far distant past. It seeks to assure us that the properties and tendencies now manifest in our surrounding world of things are in all respects similar to those which have existed in the past. Without a basis of this kind, the Evolution hypothesis would be a mere idle dream. Uniformity is for it an all-pervading necessity. Starting from facts of daily observation and from scientific experiments, the properties and tendencies of things are noted and grouped; while philosophers, using the knowledge thus gained, seek to trace back the progress of events and show how this complex world has gradually been derived from a world of more and more simple composition. We are taken back in imagination even much farther. We are referred to a primal haze or nebula—as the gigantic germ of a future Universe. This was the conception of Laplace.

But whether we follow the philosopher in his bold speculations concerning the past, or listen to the biologist making his predictions concerning the future stages which the germ of a given animal will pass through in the progress of its evolution—in each case the "uniformity of Nature" is tacitly assumed. This assumption underlies almost all our thoughts and actions, even in every-day life. And, without such a belief in the Uniformity of Nature, science would be impossible—the very idea of it, in fact, could never have arisen. In its absence we could neither fathom the past nor illumine the future. As Mr. Mill said<sup>1</sup>—"Were we to suppose (what it is perfectly possi-

<sup>1</sup> "System of Logic," sixth edition, vol. ii., p. 98.



ble to imagine) that the present order of the universe were brought to an end, and that a chaos succeeded in which there was no fixed succession of events, and the past gave no assurance of the future, if a human being were miraculously kept alive to witness this change, he surely would soon cease to believe in any uniformity, the uniformity itself no longer existing."

It is true that in earlier times no absolute belief in the uniformity of Nature existed, even among the select few. The Greek philosophers, including Aristotle, recognized "chance" and "spontaneity" as finding a definite place in Nature, and to this extent they were not sure that the future would resemble the past. But as we have become more familiar with a wider range of natural phenomena, and with their mutual relations or order of appearance, so has the conception of chance or spontaneity disappeared from the scientific horizon—driven out of the field by the steady advance of Law and Order. Those who embrace the Evolution philosophy are foremost in this opinion—they believe that no effects of whatsoever kind can occur without adequate causes, and, the conditions being similar, that the same results will always follow the action of any given cause. Their whole creed is, in fact, preëminently based upon this assumed uniformity of Nature.

The present is essentially a time of transition in matters of opinion. Men who have been educated in one system of beliefs are gradually being converted to another, because the new system is thought to be more harmonious with the observed order of natural phenomena. This has been the case even with the chief exponents of Evolution. They have themselves had to unlearn much which they had previously learned. The doctrine of Evolution has thus been developed only by the sacrifice of many previous early beliefs and modes of thought. But it often happens that an old belief will—unknown, perhaps, to the person himself—leave decided traces of its previous influence, and thus prevent for a time the full realization of all the logical consequences of new views. This vestige of the old state of opinion or habit of thought is, more especially, apt to remain in directions where unexplained facts, or strong prepossessions and prejudices, bar the way. Some modes of this inconsistency may become obvious to one worker or thinker, and some to another, according to the particular direction which his investigations or thoughts may have taken; and such inconsistencies should be pointed out as they present themselves. So that, with the view of strengthening an hypothesis which I, in common with so many other workers in science, believe to be true, I now venture to allude to certain apparent anomalies in the declared opinions of the most prominent upholders of the doctrine of Evolution in this country. It seems all the more desirable that this should be done, since the inconsistencies may be easily shown to be wholly uncalled for, and to involve sundry unscientific conceptions.

Yet the modifications of opinion which appear to be demanded, on the ground of fact as well as on the ground of reason, will necessitate very considerable and almost revolutionary changes in the accepted code of biological doctrines.

An examination of the facts of science generally and of various every-day phenomena teaches us, according to the Evolutionist, that matter of different kinds, situated as it is and has been, gradually tends within certain limits to become more and more complex in its internal and external constitution. Coupling this conclusion with various astronomical data, with geological data, and with facts derived from the study of the past forms of Life upon our globe, the Evolutionist essays to penetrate through the long vista of by-gone ages, till he may rest his speculative gaze upon a vast rotating nebular mass of gaseous matter, of comparatively simple though unknown constitution, from which he supposes our Universe to have been slowly evolved. Without futile questionings as to the explanation or cause of the existence of the nebula, without speculation as to what simpler or more complex matter may have immediately preceded it, it is obvious that we may for our own convenience take up its imaginary existence at any stage. Though we must be free to admit that in concentrating our attention upon this nebular stage, or upon any other, we arbitrarily break into a mysterious cycle of existence whose Cause is to us unfathomable. It is needless for my purpose, however, to attempt to concentrate the reader's attention upon a period so remote in the history of our Universe. The primordial nebula, as it cooled and condensed, acquired a more rapid axial rotation: masses were gradually thrown off from its circumference, and these in their turn condensed into rotating spheroids, which continued to circulate round the parent mass in elliptical orbits. Assuming, then, with the Evolutionist, that our own planet had a past history of this kind, we must also assume that it gradually changed from a gaseous to a fluid state before beginning to solidify by the formation of a superficial crust—a crust which gradually thickened as the fervent heat of it and of the fluid nucleus abated by heat-radiations into space. Until this stage of the Earth's history had been far advanced, no Living Things could have existed upon its surface. "Hence," as Sir William Thomson said,<sup>1</sup> "when the Earth was first fit for life there were no living things on it. There were rocks, solid and disintegrated, water, air all round, warmed and illuminated by a brilliant sun, ready to become a garden." Living things must, however, have appeared upon its surface at some very remote epoch, since their remains are to be found far down in the rocks which at present constitute its crust. But how, it must be asked, is the first appearance of living matter upon the earth to be accounted for?

We should not needlessly invoke an abnormal act of Creative

<sup>1</sup> Inaugural Address at Meeting of British Association, *Nature*, August 3, 1871, p. 269.

Power, we must not even resort to a "moss-grown fragment from the ruins of another world," unless it is really necessary to invent some such hypothesis. Now, the Evolutionist repudiates the notion of Creation in its ordinary sense; he believes that the operation of natural causes, working in their accustomed manner, was alone quite adequate to bring into existence a kind of matter presenting a new order of complexity, and displaying the phenomena which we have generalized under the word "Life." Living matter is thus supposed to have come into being by the further operation, under new conditions, of the same agencies as had previously led to the formation of the various inorganic constituents of the earth's crust—such mineral and saline substances as we see around us at the present day. What we call "Life," then, is regarded as one of the natural results of the growing complexity of our primal nebula. So that, in accordance with this view, we have no more reason to postulate a miraculous interference or exercise of Creative Power to account for the evolution of living matter in any suitable portion of the Universe (whether it be on this earth or elsewhere), than to explain the appearance of any other kind of matter—the magnetic oxide of iron, for instance. So far, all thorough Evolutionists are quite agreed. This is the view of Spencer, Lewes, Huxley, and others—possibly of Darwin. I say possibly of Darwin, because on this subject it so happens that the language of this most distinguished exponent of Evolution is more than usually tinged with a previous point of view. Speaking of the probable commencement of Life upon our globe, Mr. Darwin says<sup>1</sup>: "I believe that animals have descended from at most only four or five progenitors, and plants from an equal or lesser number. Analogy would lead me one step farther, namely, to the belief that all animals and plants have descended from some one prototype. . . . There is grandeur in this view of life, with its several powers, having been originally breathed by the Creator into a few forms, or into one; and that while this planet has gone cycling on according to the fixed law of gravity, from so simple a beginning endless forms, most beautiful and most wonderful, have been and are being evolved." Taking into account the phraseology made use of in the above quotation, we have little difficulty in recognizing the views of an Evolutionist, dwarfed and modified though they are by an ultimate appeal to a Creative act only a little less miraculous and singular than the mythical origin of our reputed ancestors—Adam and Eve. Some existing naturalists may perhaps contend that Mr. Darwin ought to have kept more closely to the Mosaic record—replacing his one primordial form by a dual birth of male and female, without whose mutual influence no "biological individuals" can in their opinion come into existence. Such a supposition, it is true, would be as antiquated and unnecessary from the Evolutionist's point of view as

<sup>1</sup> "Origin of Species," sixth edition, 1872, pp. 424, 429.

is the whole notion of life having been originally "breathed" into one or more organic forms. Mr. Spencer's language is happily free from both these defects: he neither uses the phraseology of the Creative hypothesis, nor does he adopt a definition of biological "individuality," at variance with the Evolution philosophy. He distinctly teaches that living matter must have been at first formless, and that multiplication would have taken place, as among the lowest forms of the present day, exclusively by agamic methods — nay, more, he teaches that living matter must have been the gradual product or outcome of antecedent material combinations. "Construed in terms of evolution," he says,<sup>1</sup> "every kind of being is conceived as a product of modifications wrought by insensible gradations on a pre-existing kind of being, and this holds fully of the supposed 'commencements of organic life,' as of all subsequent developments of organic life." But on the question whether the process of Archebiosis (life-evolution) is likely to have occurred once only, as Mr. Darwin seems to hint, or in multitudinous centres scattered over the earth's surface, Mr. Spencer makes no definite statement. The latter belief would, however, be entirely in accordance with his general doctrine; and we seem all the more entitled to infer that Mr. Spencer inclines to the notion of a multiple occurrence of Archebiosis, both in space and in time, since he does not reject the possibility of its occurrence in our own day. Granting "that the formation of organic matter and the evolution of life in its lowest forms may go on under existing cosmical conditions," he believes it "more likely that the formation of such matter and of such forms took place at a time when the heat of the earth's surface was falling through those ranges of temperature at which the higher organic compounds are unstable." But conclusions which we are only able to infer from the writings of Mr. Spencer have been distinctly enunciated by Mr. G. H. Lewes. In a criticism of the "Darwinian Hypothesis," he very forcibly pointed out that it is quite compatible with the hypothesis of evolution to admit a variety of starting-points for the formation of living matter, and he consequently laid down in principle a very important extension of the Darwinian doctrine, in its application to higher organisms. He says:<sup>2</sup> "Although observation reveals that the bond of kinship does really unite many divergent forms, and the principle of Descent with Natural Selection will account for many of the resemblances and differences, there is at present no warrant for assuming that all resemblances and differences are due to this one cause, but, on the contrary, we are justified in assuming a deeper principle which may be thus formulated: All the complex organisms are evolved from organisms less complex, as these were evolved from simpler forms: the link which unites all organisms is not always the common bond of heritage, but the *uniformity of organic laws acting under uniform condi-*

<sup>1</sup> "Principles of Biology," vol. ii., Appendix, p. 482.

<sup>2</sup> *Fortnightly Review*, 1868.

tions. . . . It is therefore consistent with the hypothesis of Evolution to admit a variety of origins or starting-points." In this paper Mr. Lewes distinctly postulates the probability of a repetition of the process of Archebiosis, wherever the conditions were favorable, and though he says nothing against the continuance of such a process in the present day, neither does he dwell upon it as a probability.

Prof. Huxley's<sup>1</sup> opinions on the subject of Archebiosis are very similar to those of Mr. Spencer, with the exception that he seems more strongly opposed to the notion of its occurrence at the present day, and it is to this aspect of the question that I would now direct the reader's attention. Why should men of such acknowledged eminence in matters of Philosophy and Science as Mr. Herbert Spencer and Prof. Huxley promulgate a notion which seems to involve an arbitrary infringement of the uniformity of Nature?

They would both have us believe that living matter came into being by the operation of natural causes—that is, by the unhindered play of natural affinities operating in and upon matter which had already acquired a certain degree of molecular complexity. They believe that the simpler kinds of mineral and crystalline matter continue to come into being now as they have ever done; nay, more, they believe that the higher kind of matter, originally initiated by the operation of natural causes, continues to grow both in animal and in vegetal forms, solely under similar influences, and yet they consider themselves justified in supposing that natural causes are now no longer able independently to initiate this higher kind of matter (protoplasm). We find Prof. Tyndall<sup>2</sup> also affirming, in the most unhesitating language, the ultimate similarity between crystalline and living matter: affirming that all the various structures by which the two kinds of matter may be represented are equally the "results of the free play of the forces of the atoms and molecules" entering into their composition. And he, too, would have us believe that, while differences in degree of molecular complexity alone separate living from not-living matter, the physical agencies which promote the growth of living matter are now incapable of causing its origination.

Why, we may fairly ask, should a supposed difference be erected by Evolutionists between Origination and Growth in the case of living matter, while no one dreams of making any such distinction in reference to crystalline matter? Is it true that the process of growth differs from the process of origination, and if so in what respects? Philosophically speaking there is little difference. Take the case of the formation of the "silver tree," cited by Prof. Tyndall. A weak galvanic current is passed through a solution of nitrate of silver, and simultaneously, in a first increment of time, a number of molecules of

<sup>1</sup> "Inaugural Address at Meeting of British Association," *Nature*, September 15, 1870, p. 404.

<sup>2</sup> "Fragments of Science," fourth edition (1872), pp. 85-87, and 113-119.

oxygen and of silver begin to aggregate independently into crystals of oxide of silver; in a second increment of time the operation of the same causes produces similar results, only now part of the new crystalline matter forms in connection with the preëxisting germs of crystals, though part of it may still aggregate independently. During a third, a fourth, and in all succeeding increments of time, in which the same causes operate amid similar conditions, similar results must ensue. But, taking the process of origination which occurs in the first increment of time, would Prof. Tyndall have us believe that it is in any way different from that of growth which takes place in a second, third, or fourth increment of time? Does not the very fact that origination and growth so often occur simultaneously in the case of crystalline matter, and under the influence of the same causes, show us that the two processes are intrinsically similar, and that conditions favorable for growth are also likely to be favorable for origination? And if this be true for crystalline matter, may we not infer that it would also be true for living matter? These are questions neither asked nor answered in any definite manner by those whose opinions I have already cited. They are, however, questions by no means unworthy of an attentive consideration.

Although, as a general rule, conditions favorable for the growth of any particular kind of crystalline matter are likely to be favorable for its origination, still it must be acknowledged that the presence of a crystal will occasionally lead to its growth in a medium in which similar crystalline matter had previously shown no tendency to form independently—even in cases where the introduction of a non-crystalline nucleus would not be able to determine a similar formation of crystalline matter. In spite of the general law, therefore, that conditions favorable for the growth are also favorable for the origination of crystalline matter, we are compelled to admit that growth may be determined under certain conditions where origination does not occur, and that the presence of preëxisting crystalline matter favors the process. Now, a distinction of the same kind undoubtedly obtains in the case of living matter. We know, quite positively, that, although Bacteria will not originate in a previously-boiled ammoniac tartrate solution, or "Pasteur's solution," the addition of a few of these organisms (all other conditions remaining the same) will soon occasion a very considerable growth of the living matter of which they are composed.<sup>1</sup> We are thus reduced to ask whether the influence of the preëxisting nucleus is relatively more potent in the case of living matter than it is in the case of crystalline matter? This is a question which unfortunately we are unable definitely to answer. But, so long as we have no positive knowledge on this subject, we surely have little right to infer that processes both of origination and of growth continue in the case of crystalline matter, while the process of growth alone survives in the

<sup>1</sup> "The Beginnings of Life," vol. i., p. 325.



case of living matter. There are no facts easily discoverable upon which such an assumption can be legitimately based.

The probabilities would seem altogether in favor of the continuance of a natural process like Archebiosis after it had been once initiated, more especially when this natural process is so closely allied to another which manifests itself with the utmost readiness on all parts of the earth's surface. So that, unless very cogent reasons could be adduced against the occurrence of Archebiosis at the present day, looked at from an *a priori* point of view, there seems scarcely room for doubt upon the subject. The properties and chemical tendencies of material bodies seem to be quite constant through both time and space. Speaking upon this subject in a recent discourse on "Molecules," Prof. Clarke Maxwell says:<sup>1</sup> "We can procure specimens of oxygen from very different sources, from the air, from water, from rocks of every geological epoch. The history of these specimens has been very different, and, if, during thousands of years, difference of circumstances could produce difference of properties, these specimens of oxygen would show it. . . . In like manner, we may procure hydrogen from water, from coal, or, as Graham did, from meteoric iron. Take two litres of any specimen of hydrogen, it will combine with exactly one litre of any specimen of oxygen, and will form exactly two litres of the vapor of water. . . . Now, if, during the whole previous history of either specimen, whether imprisoned in the rocks, flowing in the sea, or careering through unknown regions with the meteorites, any modification of the molecules had taken place, these relations would no longer be preserved. . . . But we have another and an entirely different method of comparing the properties of molecules. The molecule, though indestructible, is not a hard, rigid body, but is capable of internal movements, and, when these are excited, it emits rays, the wave-length of which is a measure of the time of vibration of the molecule. . . . By means of the spectroscope the wave-lengths of different kinds of light may be compared to within one ten-thousandth part. In this way it has been ascertained, not only that molecules taken from every specimen of hydrogen in our laboratories have the same set of periods of vibration, but that light having the same set of periods of vibration is emitted from the sun and from the fixed stars. . . . We are thus assured that molecules of the same nature as those of our hydrogen exist in those distant regions, or at least did exist when the light by which we see them was emitted." With evidence such as this before us, which could be multiplied to an enormous extent, we should hesitate before needlessly postulating any infringement of the uniformity of natural phenomena.

What, then, are the reasons assigned for the non-occurrence, at the present day, of the process of Archebiosis? All that Mr. Spencer says upon the subject is, that such a process seems to him more likely

<sup>1</sup> *Nature*, September 25, 1873, p. 440.

to have occurred at "a time when the heat of the earth's surface was falling through those ranges of temperature at which the higher organic compounds are unstable," than at the present day. Why such conditions would be more favorable than those now existing Mr. Spencer does not say; and that such an alteration should suffice to put a stop to Archebiosis, although we see living matter still growing freely all over the earth under the most diverse conditions as regards temperature, seems very difficult to believe. Yet no other suggestion is offered in explanation of an assumption which seems essentially unscientific. For the assumption that Archebiosis took place only in the remote past puts this process on a *quasi* miraculous level, and tends to assimilate it to an act of special creation, the very notion of which Mr. Spencer, in other cases, resolutely rejects.

Again, what reason does Prof. Huxley give, in explanation of his supposition as to the present non-occurrence of Archebiosis? He says<sup>1</sup> if it were given to him "to look beyond the abyss of geologically-recorded time," to a still more remote period of the earth's history, he would expect "to be a witness to the evolution of living protoplasm from non-living matter." And the only reason distinctly implied why a similar process should not occur at the present day is, because the physical and chemical conditions of the earth's surface were different in the past from what they are now. And yet, concerning the exact nature of these differences, and the degree in which the different sets of conditions would respectively favor the occurrence or arrest of an evolution of living matter, Prof. Huxley cannot possess even the vaguest knowledge. He chooses to assume that the unknown conditions existing in the past were more favorable to Archebiosis than those now in operation. This, however, is a mere assumption which may be entirely opposed to the facts. It is useless, of course, to argue upon such a subject, but still it might fairly be said, in opposition to his assumption of the impotency of present telluric conditions, that the abundance of *dead organic matter* now existing in a state of solution would seem to afford a much more easy starting-point for life-evolution than could have existed in that remote past, when no living matter had previously been formed, and consequently when no dead organic matter, thence derived, could have been diffused over the earth's surface.<sup>2</sup>

Prof. Huxley is, however, very inconsistent, since, in spite of his declared expectation of witnessing the evolution of living from lifeless matter, if it were given him "to look beyond the abyss of geologically-recorded time," he had said, scarcely five minutes before, in reference to experimental evidence bearing upon the present occurrence of a

<sup>1</sup> *Nature*, September 15, 1870, p. 404.

<sup>2</sup> This is a consideration of great importance, since those who believe that Archebiosis occurs in organic solutions at the present day have not yet professed to show that it can occur in saline solutions free from all traces of organic matter.

similar process, that, "if, in the present state of science, the alternative is offered us—either germs can stand a greater heat than has been supposed, or the molecules of dead matter, *for no valid or intelligible reason that is assigned*, are able to rearrange themselves into living bodies, exactly such as can be demonstrated to be frequently produced in another way—I cannot understand how choice can be, even for a moment, doubtful." Having thus expressed himself, it was a little strange that Prof. Huxley forgot to inform his audience, five minutes afterward, what "valid or intelligible reason" he was able to assign for the occurrence of that evolution of non-living matter into living protoplasm in the remote past to which he alluded. A supernatural interposition of Creative Power would explain the presence of living things upon our earth, just as easily as a supernatural preservation of living matter from the destructive effects of heat would account for the presence of living organisms within certain experimental flasks. But Prof. Huxley most inconsistently says that, even in the face of scientific evidence concerning the destructive powers of heat upon living matter, he would rather explain the presence of organisms in certain flasks on the hypothesis of a (supernatural) preservation of germs, than believe in the otherwise proved occurrence of a present life-evolution, similar to that which he assumes to have taken place in the past. He is willing to accept the supernatural in the present, though he declines to interpret the past by its aid. He assumes this attitude because no "valid or intelligible reason" is assigned in explanation of life-evolution, a belief in which would render unnecessary any appeal to the supernatural in the present; though he himself postulates the occurrence of the same unexplained process in the past, solely in order to avoid recourse to the supernatural. Prof. Huxley's position in reference to this question is very puzzling, and one cannot help wondering through what monochromatic glass he had been taking his observations (from his "watch-tower"), in order to come to the conclusion that "the present state of science" gives any sanction to such vacillations, or entitles him to appeal to a supernatural preservation of germs, instead of trusting to the known uniformity of natural phenomena.

Sir William Thomson was certainly much more consistent. He, too, seemed inclined to explain the experiments of our own day by resorting to the hypothesis of a supernatural preservation of germs, and similarly, he seems not unwilling to explain the original advent of Life upon this globe, by another assumed process of "Contagion." He has resort neither to a creative hypothesis nor to the hypothesis of a natural becoming of living matter, but, shelving the question of "origin" altogether, he suggests that our earth may have become peopled with organic forms, owing to the advent upon it, in the remote past, of a "moss-grown fragment from the ruins of another world." Sir William Thomson's hypothesis seems strangely improb-

able in itself, though it has, in comparison with the views of others, the somewhat rare merit of being not inconsistent with his notions concerning the experiments of to-day. He does not reject the supernatural in the past, while resorting to it for the present—he resorts to it in the present and in the past alike, and curiously evades the problem of origin altogether.

Since so little—or, rather, nothing—is said by Prof. Huxley in support of his supposition that living matter does not originate in the present day, even though the process of origination is so closely akin to that of growth; and, though the process of growth is taking place at every moment of our lives, in every region of the globe, and under the most varied conditions—amid tropical heat and icy coldness, on mountain-tops and deep down in almost unfathomable ocean-beds—it seems only reasonable to suppose that he must have been influenced by some prepossessions. And, so far as one can gather from his presidential address before the British Association—from which I have already quoted—he does not appear to have been powerfully biased by theoretical considerations. One of these we shall now consider.

Much stress is laid by certain writers upon the fact that “the doctrine of spontaneous or equivocal generation has been chased successively to lower and lower stations in the world of organized beings, as our means of investigation have improved.”<sup>1</sup> So that, as another very eminent writer says, “if some apparent exceptions still exist, they are of the lowest and simplest forms.”<sup>2</sup> And it is usually inferred from this fact that further knowledge and improved means of observation will prove these apparent exceptions to be no exceptions to the supposed general rule—*omne vivum ex vivo*. A consideration of this kind seems to have powerfully influenced Prof. Huxley. But much confusion exists in reference to the point, which needs to be removed. In the first place, it must be freely admitted that many ancient notions, dating from the time of Aristotle, on the subject of “Equivocal or Spontaneous Generation,” were altogether crude and absurd. Secondly, it is necessary to distinguish (and Prof. Huxley did so) between two meanings of the phrase, which have often been confounded with one another—viz., between Heterogenesis, or the mere allotropic modification of already existing living matter, and Archebiosis, or the independent origination of living matter. Thirdly, it should be distinctly understood that those who strictly adhere to the Evolution hypothesis could never believe in the origination of any but the “lowest and simplest” organic forms by a process of Archebiosis. So that, as Prof. Huxley professes himself an Evolutionist, the objection above indicated should have been quite pointless for him. Molecular combinations, giving rise to units of protoplasm far below the *minimum*

<sup>1</sup> Prof. Lister, “Introductory Lecture” (University of Edinburgh), 1869, p. 12.

<sup>2</sup> Mr. Justice Grove (“Presidential Address”), Report of British Association for the Advancement of Science, 1866, p. 71.

*visible* stage of our most powerful microscope, would represent those initial collocations by which alone living matter could come into being—though the “germs” thus initiated may afterward appear as minutest visible specks growing into Bacteria, Vibriones, or Torulæ. We may, therefore, be permitted to remark that, even if it were given to Prof. Huxley to “look beyond the abyss of geologically-recorded time,” he would be extremely unlikely to witness an “evolution of living protoplasm from not-living matter.” At the most, he might see (that is, if equipped with a powerful microscope) only what he may equally well see now—viz., a gradual emergence into the sphere of the visible of minute specks of living protoplasm. But though *he* might, when looking back to this remote age, be inclined to consider such appearances as testifying to the evolution of living protoplasm from not-living matter, he would perchance find it just as difficult to convince others of the absence of invisible Salamandrine germs (derived, perhaps, from the “moss-grown fragment of another world”) as he is himself difficult to be convinced by similar appearances at the present day. Prof. Huxley seems, for the time, to have lost sight of a consideration justly deemed by Prof. Tyndall to be one of great importance in the interpretation of evolutionary phenomena—viz., the enormous difference in point of size between the first constituent molecules of protoplasm and the minutest visible organisms. As Prof. Tyndall puts it, compared with their constituent elements, “the smallest vibrios and bacteria of the microscopic field are as behemoth and leviathan,” even though the latter are often less than  $\frac{1}{30000}$  of an inch in diameter.

Thus it would appear that a consistent belief in the Evolution hypothesis necessarily carries with it a belief in the continuance of the process of Archebiosis from the remote epoch when living matter first appeared upon this earth down to the present time. The Evolutionist teaches us that living matter is not in its essence different from other kinds of matter, and that it originally came into being, like the various forms of mineral and crystalline matter, by the operation of mere natural causes. As Prof. Huxley says:<sup>1</sup> “Carbon, hydrogen, oxygen, and nitrogen, are all lifeless bodies. Of these carbon and oxygen unite in certain proportions and under certain conditions to give rise to carbonic acid; hydrogen and oxygen produce water; nitrogen and hydrogen give rise to ammonia. These new compounds, like the elementary bodies of which they are composed, are lifeless. But, when they are brought together under certain conditions, they give rise to the still more complex body, protoplasm; and this protoplasm exhibits the phenomena of life.” So that, if living matter has once arisen naturally and independently, the laws of uniformity alone, upon which all science is based, should lead us to expect

<sup>1</sup> “Fragments of Science,” fourth edition, 1872, p. 151.

<sup>2</sup> *Fortnightly Review*, February, 1869.

that it would continue to have a similar "origin" so long as such matter continued to "grow" under the most varied conditions upon and beneath the earth's surface. And, these conditions being fulfilled, we have a good *a priori* warrant for the belief that living matter is continually coming into being by virtue of the operation of the same "laws" or molecular properties as suffice to regulate its growth.

Let the Evolutionist attempt to deny it, and see what other difficulties he plunges into, in addition to that lack of consistency which I have already pointed out.

If an evolution of living matter occurred only far back beyond the depths of geologically-recorded time, and if, as Mr. Darwin<sup>1</sup> would have us believe, "all the living forms of life are the lineal descendants of those which lived long before the Cambrian epoch," how is the Evolutionist to explain the existence of the multitudinous myriads of lowest and almost structureless organisms which exist at the present day? He starts, in his argument in favor of Evolution, from the fact that the condition of homogeneity is one of necessarily unstable equilibrium. All homogeneous matter inevitably tends to become heterogeneous, and, of the different kinds of matter, none unites within itself the various qualities tending to favor this passage from the homogeneous to the heterogeneous in the same degree as living matter. These tendencies are daily exemplified to us by the phases of embryonic development passed through by the more or less homogeneous germs of multitudinous complex organisms from which they proceed. The embryonic development of one of the higher animals—of man himself, for instance—is a kind of highly-condensed epitome of animal evolution in general. And the varied forms of life of higher organization, both animal and vegetal, which have existed and still exist upon the surface of our earth, are all supposed by the Evolutionist to have arisen by dint of insensible modifications wrought through the long lapse of ages upon successive generations of organic forms. But if living matter contains within itself the potentiality of undergoing such mighty changes and of ever growing in complexity—if from originally structureless protoplasm (that is, structureless, to our senses) all the varied forms of life have been derived, how is it that some of this very same matter should have remained through the long lapse of ages almost in its primitive structureless condition?<sup>2</sup> Why should one portion of the living matter which came into being in pre-Cambrian epochs have passed through such marvelous changes, while another portion has continued to grow, through all the inconceivably numerous generations which must have occurred between that time and the present, without undergoing change?

In other words, what is the meaning of the existence of Bacteria,

<sup>1</sup> "Origin of Species," sixth edition, p. 428.

<sup>2</sup> The multiplication of the lowest forms of life takes place so simply that, as Prof. Huxley has pointed out, it is nothing more than a process of "discontinuous growth."



Torulæ, Amœbæ, and such simplest organisms at the present day?<sup>1</sup> Mr. Spencer saw this difficulty, but apparently did not fully realize its force. He attempts, as it appears to me, very inconsistently to evade it by supposing that living matter may escape increasing organization so long as it can escape the influence of gross changes in external conditions; and, just as inconsistently, he assumes that living matter could escape these changes in external conditions through that long lapse of ages which the lowest estimate regards as a period of no less than 100,000,000 years. Speaking of what he presumes to be ancient though almost structureless organisms, and endeavoring to account for their stationary condition as regards structure, by supposing that they have succeeded through long ages in "dodging" all changes in their environment, Mr. Spencer says: "New influences are escaped by the survival of species in the unchanged parts of their habitats, or by their spread into neighboring habitats which the change has rendered like their original habitats, or by both."

Now, in opposition to these views of Mr. Spencer, many very cogent objections may be alleged. In the first place, in supposing that the organization of living matter would not increase even through ages of time unless it were subject to marked variations in external conditions, Mr. Spencer makes a supposition which seems notably at variance with his own doctrines of Evolution. Does he not for a time ignore those internal causes of change which must ever be in operation within living matter as within all other kinds of matter—and which, even in combination with approximately fixed external conditions, should suffice to produce a continually-increasing differentiation (organization) in living matter? Mr. Spencer himself says: "All finite forms of the homogeneous—all forms of it which we can know or conceive—must inevitably lapse into heterogeneity. In three several ways does the persistence of force necessitate this. Setting external agencies aside, each unit of a homogeneous whole must be differently affected from any of the rest by the aggregate action of the rest upon it. The resultant forces exercised by the aggregate on each unit, being in no case alike both in amount and direction, cannot produce like effects on the units. And the various positions of the parts in relation to any incident force preventing them from receiving it in uniform amounts and directions, a further difference in the effect wrought on them is inevitably produced." Even this is not all; Mr. Spencer also points out that "every differentiated part is not simply a seat of further differentiations, but also a parent of further differentiations; since, in growing unlike other parts, it becomes a centre of unlike reactions on incident forces, and, by so adding to the diversity

<sup>1</sup> Especially when Mr. Darwin says: "Judging from the past, we may safely infer that not one living species will transmit its unaltered likeness to a distant futurity."—*Origin of Species* (1872), sixth edition, p. 428.

<sup>2</sup> "First Principles," second edition, pp. 429, 548.

of forces at work, adds to the diversity of effects produced. This multiplication of effects is proved to be similarly traceable throughout Nature." Now, if causes like these are inevitably at work upon and within the simplest forms of life, no change in external conditions would be needed in order to insure an increasing complexity of structure, through months or years, to say nothing about long ages of time. But, as a matter of fact, granting that the liability of organisms to increase in complexity of structure "arises from the actions and reactions between organisms and their fluctuating environments," and seeing that these changes in the environment are enumerated by Mr. Spencer as being due to "astronomic, geologic, meteorologic, and organic agencies," organisms never could by any possibility shelter themselves through long ages of time even from the influence of these external inciters of change. Mr. Spencer's explanation of the cause of the existence of multitudinous almost structureless organisms at the present day, therefore, entirely falls to the ground. The lowest organisms can neither escape the incidence of new external conditions (such as we know from actual observation do powerfully modify them), neither, if they could, should the progress of organization thereby cease—since the internal causes of change would still remain active and still continue to give rise to a "multiplication of effects," as Mr. Spencer has himself explained.

Thus, the existence of such lowest and simplest organisms as the microscope everywhere reveals at the present day, is quite irreconcilable with the position that life-evolution has not occurred since an epoch inconceivably remote in Time. Admit the present occurrence of Archebiosis and Heterogenesis, and both the existence and protean variability of the lowest organisms are at once readily explained. We may suppose them continually seething into existence afresh, endowed with enormous plasticity; so that new recruits are constantly appearing, ever ready to fill up the gaps which would otherwise be occasioned by promotion and death. The opposite doctrine, concerning such organisms as the structureless *Amœba* and the insignificant *Mucor* now daily appearing on decaying substances, seems opposed to all reason from the point of view of the Evolution Philosophy. As I have elsewhere asked:<sup>1</sup> "Would the Evolutionist really have us believe that such forms are direct continuations of an equally structureless matter which has existed for millions and millions of years without having undergone any differentiation? Would he have us believe that the simplest and most structureless *Amœba* of the present day can boast of a line of ancestors stretching back to such far remote periods that in comparison with them the primeval men were but as things of yesterday? The notion surely is preposterously absurd; or, if true, the fact would be sufficient to overthrow the very first principles of their own Evolution philosophy."—*Author's Advance Sheets.*

<sup>1</sup> "The Beginnings of Life," 1872, vol. i., p. 12.

## ON THE ÆSTHETIC SENSE IN ANIMALS.

TRANSLATED FROM THE FRENCH OF LOUIS VIARDOT.

By A. R. MACDONOUGH.

THE mind of animals is a very old subject of discussion. Descartes and his school regarded an animal as a mere piece of machinery, like a clock or a turnspit. For man alone they reserved intelligence, meaning by that, memory, feeling, will, and reason. The story of Malebranche is well known: As he was going into his convent at the Oratory with a friend, a little bitch ran up and fawned on him; he gave her a kick which sent the poor beast yelping off, and when his friend expressed surprise that so gentle, kindly, and Christian a person returned kicks for caresses, he exclaimed, "What! do you really suppose that that animal had any feeling?" Thus Malebranche not merely believed he had not wounded or grieved her; he even thought he had caused her no physical pain. This was denying clear proof, and pushing faith in his master's doctrine to absurdity.

On the other hand, Montaigne, Leibnitz, La Fontaine, Bayle, Condillac, Madame de Sévigné, agreeing with all antiquity, from Pythagoras to Galen, assert that animals have all the organs of sensation and of feeling; that they possess will, desires, memory, ideas, combinations of ideas, and even the power of performing some moral acts, such as entertaining attachment like that a dog feels for his master, or a hen for her chicks; or, like "that very just equality which they practise in dividing food or other good things among their young," as Montaigne says; and that therefore the intelligence of animals, if not equal to man's, is at least like it, and that the differences between the oyster anchored to its rock and the *homo sapiens* of Linnæus are merely differences between more and less, degrees of succession that make up what is called the scale of being. It is the latter opinion that has been declared triumphant by the researches of natural history and those of comparative anatomy alike. On this point science has reached certainty, and every one, reading the story of "the two Rats, the Fox and the Egg," says now with La Fontaine:

"After that tale, where's the pretense  
That animals are lacking sense?"

But another dispute has just been opened on this question: "Have animals the sense of beauty, the æsthetic sense?" The famous Charles Darwin, and his numerous followers agreeing with him, displaying even greater generosity than Montaigne, Leibnitz, and La Fontaine, answer unhesitatingly in the affirmative. In their view, just as animals are endowed with intelligence as well as man, though in a lower degree, so in the same way and in the same proportion they

are endowed with the sense of beauty. They find the proof of this rather bold assertion, not in natural selection, which is a result of that struggle for life in which the weakest individuals among species, and the weakest species among genera, must disappear, but in sexual selection, which is a result of the struggle for reproduction, leading straight to the same consequences, namely, to the improvement of species and genera, which reaches, by slow elaboration through ages, even to their transformation. Among all animals, they say, among insects, fish, birds, mammals, the male chooses his female, and the female chooses her mate. If strength often determines the choice, so beauty often does too. The charm of graceful shapes, pleasing colors, fine notes, has great weight in settling the preference. Now, this charm which the male possesses habitually in a far higher degree than the female, he could have no occasion for whatever in the struggle for existence; he can benefit by it only in the struggle for reproduction. Hence all those displays of genuine coquetry which may easily be observed, in pairing-time, among all animals; hence those attractions prevailing through vigor of form, brilliant hues, and impassioned song. This general fact, well established under differences of appearance among all species and all genera, gives the Darwinian school ground for asserting that animals, having the perception of beauty, have consequently the æsthetic sense.

The opposing school, including of course all who prefer metaphysics to physiology, is by no means wanting in excellent answers. It says, by the pen of Charles Lévêque (in the *Revue des Deux Mondes* of September 1st), "the doctrine of Darwin rests, in its last analysis, on the capital fact that the animal, the male sometimes, the female sometimes, often both at once, is susceptible to the beauty of its kind. That the animal is struck with it, we admit; but does it feel really this beauty of color, form, and song, in so far as it is beauty, or is it not rather the fact that those brilliant tints, that vigor, that sweetness of voice, form for the animal an indication, very expressive, yet merely brute-like, of a physiological condition which its instinct expects, which itself stimulates and answers to?" And this question, which must involve in its solution that of the former one too, the anti-Darwinians answer in the affirmative, which is the negative of the first question. They point out that this process of choice, in which beauty wins the prize, takes place only at the season of pairing, and ceases through all the rest of the year; that if we concede to the animal a sense of the beautiful, within those limits, still the sense has but one special object, finds its range within the species merely, never reaches to a less concrete conception, does not widen, does not perfect itself by tradition and culture, remains unchangeably set on the same object, the same time, the same point; that admiration which grows from the expansion of this sense of beauty can only spring from very varied and delicate comparisons; in one word, that the animal, being

unable to attain general and abstract ideas, cannot rise to the æsthetic sense. To conclude: that sense is the exclusive endowment of man.

This is a concise statement—for neither our subject nor our powers allow us to take a side in this discussion—of the interesting controversy raised by Mr. Darwin's last book. We only say that, notwithstanding the deep respect and the frank support that we give to his general doctrine, we here adopt the opinion of his opponents. We, too, believe that the æsthetic sense, in the high and perfect acceptance of the phrase, belongs to man alone. But we must here suggest a correction of the highest importance, which will at once define our opinion, and lead us to a fundamental reflection upon the arts.

“Complete the experiment,” M. Charles Lévêque says. “Place your animal before a work of art representing its male or its female with a precision that deceives the eye; some of these works that seemed to live existed in the studios of ancient painters; they are more frequent in modern museums and exhibition-rooms. It was said that mares would neigh when going before horses painted by Apelles. A dog would perhaps stop a moment in front of Oudry's hunting-pieces, if their frames were put on the floor, within reach of his look. He would come up, examine them, ask the canvas a single question with his infallible scent—and that would be all. And yet, what is there in the picture? There is exactly the element worthy of admiration, that is to say, the expression of life by means of the most attractive colors and the most perfect forms. What does the quadruped care for these as he looks at this wonder? It is not the expression of life in general that he wants; it is life itself, individual life, life which speaks to his senses, and to that of smell much more strongly than to his eyes and ears. He has no concern with the general, the ideal, the admirable; he understands nothing about them.”

This is all strictly and absolutely true. We have never put much faith in the stories invented by the Greeks and collected by Pliny; we have never remarked, in our long experience as a sportsman, that the most intelligent of man's companions ever gave the least attention to any object represented by painting or sculpture, even to his master's portrait, or that he looked with any feeling of satisfaction at one of those charming landscapes set before us at every step by Nature, enchanting as their view is to us. That seems to us one settled fact. But is M. Lévêque quite certain that *all* men have any greater faculty for that notice and that knowledge which are wanting in the dog? Have savages got above the level of animals in this respect? A traveler, who has studied Australia thoroughly, relates that at a gathering of some native inhabitants of that country he brought out portraits of Queen Victoria and Prince Albert, to see what they would think of them. Almost all kept silence, seeing nothing in the pictures at all within their range, or that touched their

memory. But two of them, and the most intelligent ones among the tribe, such as can count as far as four, ventured on a remark. One said, "It is a boat"—the other, "It is a kangaroo."

All savages would answer in the same way, yet they are men. But, although they too love beauty after their fashion, though they have a strong liking for ornament, a great disposition for coquetry, savages do not go further than the special and individual object; they do not rise to a general, abstract idea; they know no more than the dog knows about seeing life in the representation of a living being. Therefore we need to correct the formula of Darwin's opponents, and may possibly thus succeed in bringing friends and enemies into agreement; their phrase must read, "The æsthetic sense belongs to civilized man alone."

In truth, it is not an innate faculty; it is a faculty acquired by tradition, by personal study, by the development of all the other faculties. The Australians must first learn to count as far as the number of fingers on the hand, and something more than that, before they can be able afterward to understand that pictures of a man and a woman, even if disfigured with a cap or crown, are neither boats nor kangaroos.

This assertion, that the æsthetic sense belongs only to civilized man, may be proved by both philosophic methods and by arguments which I take the liberty of stating concisely, as I have set them out at length in a treatise on the question "How should art be encouraged?" The subject is worth the risk of incurring ridicule for copying one's self. We may call it, if you choose, a second edition.

*A priori*, were we to assert that equality before the law means equality in intelligences, and that every man who has the right to be a citizen has the power to be an artist, we should commit a fundamental mistake. This would be confounding the feeling of the good in our nature with the feeling of the beautiful. The former is the instinctive knowledge of good and evil, of the just and the unjust; it is born with us, it is conscience itself, and, as such, it is necessary for all. The latter is a certain delicacy of sensation and of judgment which is formed very gradually in the course of life; it is called taste, and is useful only to a few. The feeling of the good, which marks the grand superiority of man over the animals, and forms the common basis of all societies, is an essential element in our nature, a gift we are forced to accept from the creative power. Without it, man would not be man. On the contrary, the feeling of the beautiful, which is less necessary, and may well be rare because it is superfluous, is an acquisition won by intelligence, slowly, painfully, uncertainly, and is often denied to the most honest efforts. One, like rank, costs nothing but the trouble of being born: the other demands, as all acquired knowledge does, a previous fitness, a kind of revelation, in which chance must often lend Nature its aid, besides time, reflection, mental labor in bodily leisure.



*A posteriori*: it is plain that a man's first movement, as regards the good, is almost always right; as regards the beautiful, almost always wrong. Listen to the crowd, judging by its moral estimate of an event that has taken place under its eyes, when no interest nor passion misleads it: what good sense, what fairness, what insight, what right intentions, what generous sympathies! Then hear it discoursing on the merit of works of art: what wretched taste, what glaring mistakes, what ridiculous enthusiasm, what sad and utter going astray! "The people," writes Diderot to Grimm, "looks at every thing, and gets at the meaning of nothing." But do you ask for still more decisive and clear practical proofs of the immense distance that separates knowledge of the good from that of the beautiful in the human mind? A petit jury, though it decides on the liberty, life, and honor of an accused person, is drawn merely by lot, because each citizen can judge as well as every other, upon evidence and discussion, of the truth and morality of an alleged fact. But do we choose the jury which has to award the prize of a competition from the same list and in the same way? No! in that case we must choose among the most skilled and the best qualified specialists.

But what need of demonstrating what his own experience tells every one? Among these skilled and special jurors where is the one who will not confess that he at first was, and long continued to be, the dupe of his ignorance? Which of them is not aware that taste for the arts, and, still more, taste in the arts, came to him only after a long time, after lucky and often casual experiences, after protracted studies, repeated comparisons, a constant exertion of the powers of seeing, understanding, feeling, judging? And who does not know, by having learned it in himself, that in the arts—except perhaps in music, which filters in unconsciously to those who hear it—emotions come in the train of reasonings, and that the first condition of positive admiration is knowledge? "I am fully persuaded," says Sir Joshua Reynolds, in one of his "Fifteen Discourses," "that the pleasure yielded us by the perfections of art is a taste which we acquire only by long study and with much labor."

Those who choose to attribute too liberally to all men the sense of the beautiful as well as that of the good, attempt to support their opinion by a fact. They cite the instance of Athens, where, they say, competition in the arts was open to all in the public arena, where the whole people formed the tribunal. The instance is misleading, and I take it the other way, to sustain my proposition. Without insisting on the special genius of ancient Greece among the other nations of the world, and that of the Athenian people among the other peoples of Greece, I will merely point out that this people of Athens, so small in its territory and population, so great in its deeds and renown, consisted of about forty thousand free citizens, served by four hundred thousand slaves. Now, the slaves, charged with all manual

tasks, and practising all the trades, relieved their masters from bodily labor, made them men of leisure, and consecrated them to the exclusive cultivation of the intellect, like the head of a body of which they were themselves the acting and subject limbs. That Athenian democracy, how jealous soever it might be of equality between citizens, was thus a real aristocracy; and we can very well understand how the decision on matters of art might be trusted to the multitude, when that multitude consisted entirely of men so enlightened, by education and experience, that all public functions and all magistracies might be distributed among them by lot, without any great danger to the state. The empire of the arts, though it refuses to accept any boundaries as haughtily as that of science does, though speaking as well a universal language it spreads over the whole world, can be ruled only by a strict oligarchy. Indeed, as has been justly said, good taste is the quintessence of good sense. Therefore, whatever may be our devotion to equality before the law, we can never admit equality before genius, or even before that talent which the cultivation of art requires.

Among mankind art has been, and always will be, the exclusive share of a small minority; in fact, a very choice and very limited aristocracy. It is assuredly not that of birth, for there is nothing more personal than genius or talent. It is aristocracy in its true and genuine sense—the privilege of the best. Art belongs only to certain exceptional natures, very rare because they are highly endowed, whose possessors must combine with the choicest moral faculties, imagination with judgment, feeling with taste, other precious physical faculties, clearness of view, and precision of touch. All men may be artisans; only the best, the *aristoi*, can be artists.

To conclude, and still taking the phrase “æsthetic sense” in its highest and perfect meaning, we first deny it to animals; and next, holding this delicate sense to be one of the noblest attributes of mankind, we restrict it to civilized man; then last, even among nations whom continued and general cultivation places in the front rank of humanity, we allow this æsthetic sense only to some groups of select men, on whom the nature of their minds and their taste formed by long study confers this rare and precious privilege. Has not Stendhal declared that all literary reputations are made by a choice circle of five hundred readers? And it is a certain truth that the number of bachelors of arts is still smaller than the number of bachelors of letters.

However, not to overstep the very modest part suited to mere writers and professional critics, let us hasten to add that, if in art the public voice is that of a very small number, but acute, practised, and disinterestedly enthusiastic; if this voice alone decrees to the living the rewards of celebrity, to the dead the immortality of fame; if, moreover, this choice circle of connoisseurs has the sole right of

criticism, it by no means follows thence that every one of its members has the gift of infallibility. Far from that; it is like that aristocratic democracy of Athens, in which each citizen had his personal vote only, and could prevail only on condition of convincing. As in the domain of the good there is but one authority—conscience, so there is but one authority in the domain of the beautiful—taste. Only, conscience speaks the same language to all the men of one community; while taste, on the contrary, even acquired and formed taste, is as manifold as temperaments, ideas, and passions are. It varies from country to country in every age, and from age to age in every country. Still further, it varies between man and man, and in each man, at different periods of life. The bear in the fable very sensibly says:

“Who tells you this shape’s awkward, that one fine?  
Has yours the right to judge or censure mine?”

Therefore it is in vain, as if in strict pursuance of a duty, to read all books, listen to all counsels, ask advice from people supposed to be cleverer than one’s self, and prop up one’s judgment by more sure and authoritative judgments. In the criticism of art, where positive canons are wanting, no one is suffered to deem himself an authority; no one is any thing more than an opinion.—*Gazette des Beaux Arts.*



## A YEAR OF GEOGRAPHICAL WORK.

**A**T the annual meeting of the American Geographical Society, held on the 13th of January, 1874, the address was delivered by the President of the Society, Chief-Justice Daly, who gave to a large and intelligent audience an admirable digest of geographical work and progress during the past year. In his elaborate and most instructive remarks, after dilating on the object and use of geographical societies, and making special allusion to the great results of what might be called the geographical society formed by Prince Henry and his associates upon the promontory of Sagres, in Southern Portugal, viz., the discovery of the passage to the East Indies by the Cape of Good Hope, the president went on to state that there is yet one-seventeenth part of the globe of which we know nothing, except by conjecture, especially in the north and south polar regions, in Central Africa, in the interior or northern parts of Australia, and some of the great East Indian islands, e. g., Borneo and New Guinea. Many regions in South America, in Asia, and even a considerable portion of our own Western country, are not yet fully explored. These may yet be outlets for the surplus population of longer-settled and overstocked countries. Geographical research aids the progress of physical geography, especially our knowl-

edge of the wind and ocean currents of the globe, and the mysterious laws of terrestrial magnetism.

It was with the object of stimulating geographical inquiry that the first geographical society was formed in Great Britain forty-three years ago. There are now thirty-three similar societies over the globe, viz., in England, France, Holland, Belgium, Italy, Spain, Germany, Hungary, Russia, India, United States, Mexico, Brazil, and Buenos Ayres. These more or less influence public opinion, governments, and wealthy individuals, willing to aid exploration, and the expeditions of the year have been unusually numerous. Never has there been such zeal as during the last quarter of a century, from their associated efforts. It is only very large and wealthy societies, like those of London and St. Petersburg, however, which can engage in distant and expensive explorations, but all can aid in pointing out suitable fields for exploration, and impressing on the age the necessity and value of it.

In reviewing the geographical work of the world during the year, President Daly commenced with the Coast Survey, which Humboldt in 1851 said would hereafter be our great scientific monument. The valuable practical land operations of the Engineer Corps, U. S. A.; the labors of the Hydrographic Office at Washington; the United States Geological and Geographical Survey of the Western Territories; the Yellowstone Expedition under General Stanley, and the less military one under Captain Jones, with their valuable scientific results—were in turn treated in detail; after which the president reviewed Lieutenant Wheeler's exploration of the White Mountains of Arizona. The Yale College Expedition, instituted by Prof. Marsh, to explore between Salt Lake City and the Colorado River, gave us five tons of fossil and other collections. The explorers received great attention from the Mormons, owing to the discovery of fossil remains of various species of horses. Certain events are related in the Book of Mormon as occurring in the prehistoric period of America, in which horses are mentioned. According to the Spanish historians, horses did not exist in America till introduced by their countrymen, and this statement has been taken as evidence that the Book of Mormon is a fabrication. The Mormons, therefore, regard Prof. Marsh's discovery of fossil horses in Oregon as a proof of the inspiration of the Book of Mormon. The expedition and researches of Dall, in the Aleutian Islands and North Pacific, are also interesting.

The archæological discoveries of the year were next briefly reviewed, and more fully the voyage of the *Polaris* by way of Smith's Sound to within little more than 400 miles of the north pole. A Swedish expedition was sent out, under Prof. Nordenskiöld, to Parry Island; a Norwegian to the east of Spitzbergen, and an Austrian to the east of Nova Zembla. The practicability of a ship-canal across the Isthmus of Darien, by way of the Atrato, has been tested by an expedition under Commander Selfridge, and, by Commander Lull, of an-

other route from Greytown, by San Juan River and Lake. Prof. James Orton, of Vassar College, just returned from South America, has added a great deal of valuable knowledge of the geography and zoology of Amazonia. Hurlbut has crossed the Cordilleras from Lima to Lake Titicaca, while Captain Musters has journeyed through Patagonia. A narrative of the valuable explorations of Señor Raimondi in the little-known portions of Peru, to the west of the Andes, is to be published by the Peruvian Government.

The main geographical work of Europe has been the carrying out of those valuable national topographical surveys on which, as the recent Franco-Prussian War shows, the fate of nations may depend. The agreement of the Meteorological Congress, held at Vienna, was unanimous as to the great importance of synchronous meteorological observations all over the world. The scientific results of the Challenger's voyage, and of Prof. Mohn's deep-sea investigations to the north of Europe, were next alluded to.

Asia has been the scene of considerable activity in geographical exploration. Elias has traveled, almost alone, from Peking to St. Petersburg, across Chinese Tartary. The Russian capture of Khiva will produce important geographical and political results. Among the most important of recent geographical expeditions is that of Mr. Jacob Halevy, through Yemen, in the Arabian Peninsula.

Both the English and the American societies have been surveying and exploring in Palestine, the labors of the former being nearly ended, those of the latter only entered upon. The English expedition, under Captain Warren, employed chiefly in exploring Jerusalem, with branch expeditions to the plain of Philistia, and the comparatively unknown regions east of the Jordan and Mount Lebanon, has settled disputed questions, determined astronomically the position of many places, aided in elucidating ancient history, and also added much to our knowledge of local topography. The British Ordnance Survey of the Peninsula of Sinai has, among other things, remarkably corroborated the truthfulness and accuracy of Biblical history, as did also the examination of the desert of the Exodus by Prof. Palmer and Mr. Drake. By arrangement with the English society, the country lying to the east of the Jordan and Dead Sea has been undertaken by the American Palestine Exploring Society, under Lieutenant Steever, U. S. A. This embraces the lands of Moab and Edom, where the celebrated Moabite Stone was found, which illustrated so fully the origin and history of our alphabet, and the art of writing. The surveys for the various railroad routes between London and India were then briefly alluded to.

The geographical intelligence from Africa is varied, but not so interesting as during the previous year. It embraces Nachtigall's journey in the Wadai country; that of Rohlf's from North Africa to Lagos; the Livingstone relief expedition of Cameron; Sir S. Baker's efforts to suppress the slave-trade in the Upper Nile region; Miani's travels

along the White Nile to the Monbutta country, where he lost his life. A difficult journey was made by Prof. Blyden to Falaba, a little-known country to the northeast of Sierra Leone. Marche and Compeigne are now penetrating Equatorial Africa in the vicinity of the Gaboon. Besides these, it should be remembered that hundreds of residents, living on the coast or having trading outposts in the interior, annually contribute a rich fund to geographical knowledge by correspondence or publications. Among these are Bushnell of the Gaboon, who supplies valuable letters, Hansell of Khartoum, and Munzinger Bey, one of the ablest geographers and most experienced travelers, and corresponding member at Masswah of the American Geographical Society. The effect of the Anglo-Ashantee War on our geographical knowledge cannot yet be fairly estimated.

In Australasia the eastern shore of New Guinea has been explored by Captain Moresby, of the British Navy, in H. M. S. Basilisk, who dispels many false impressions prevalent regarding that hitherto little-known but highly-interesting island and its inhabitants. The island has been crossed from Geelvinks Bay to McClure Gulf by Dr. Meyer, who, like Moresby, but unlike Beccari, who has been exploring there, gives a favorable account of the island and its people. Formosa has been traversed from north to south by Thompson and Maxwell, who found coal. It would be premature to speak of the geographical results of the Dutch Acheen expedition.

Mr. Ernest Giles and Baron von Müller have been exploring Central Australia, and gathering much accurate geographical information. The telegraphic event of the year has been the construction of a line across Australia, from Adelaide in the south to Port Darwin on the north coast, a distance of 2,012 miles, which gives a continuous line from Adelaide to Gibraltar, a distance of 12,462 miles, of which 9,146 are submarine, by which Australia has three weeks' earlier news than by the mail-steamers. The last geographical intelligence from Australia is the discovery of thousands of acres of the richest sugar-growing land near Cardwell, in Northern Queensland, by a government exploring expedition. Judge Daly's instructive address, of which we have only given an outline, is well worth careful perusal, nor can its fresh and valuable details fail to awaken a fresh and wider interest in geographical science, or to give a renewed impetus to geographical discovery, while showing that America and Americans are not behind the age in geographical zeal and enterprise.

In an appendix we also find some valuable information regarding the United States Geological Survey of the Territories (Montana, Idaho, Wyoming, and Utah), in 1872, extracted from the report of the Government geologist, J. V. Hayden.



SKETCH OF PROFESSOR HUXLEY.<sup>1</sup>

BY ERNST HAECKEL,

OF THE UNIVERSITY OF JENA.

THOMAS HENRY HUXLEY was born at Ealing, on May 4, 1825. With the exception of two and a half years spent at the semi-public school at Ealing, of which his father was one of the masters, his education was carried on at home, and in his later boyhood was chiefly the result of his own efforts. In 1842 he entered the medical school attached to Charing Cross Hospital, where, at that time, Mr. Wharton Jones, distinguished alike as a physiologist and oculist, was lecturing on physiology. In 1845 Mr. Huxley passed the first M. B. examination at the University of London, and was placed second in the list of honors for Anatomy and Physiology, the first place being given to Dr. Ransome, now of Nottingham. After some experience of the duties of his profession among the poor of London, in 1846 he joined the medical service of the Royal Navy, and proceeded to Haslar Hospital. Thence he was selected, through the influence of the distinguished arctic traveler and naturalist, Sir John Richardson, to occupy the post of assistant-surgeon to H. M. S. Rattlesnake, then about to proceed on a surveying voyage in the Southern Seas. The Rattlesnake, commanded by Captain Owen Stanley, with Mr. MacGillivray as naturalist, sailed from England in the winter of 1846. She surveyed the Inner Route between the Barrier Reef and the East Coast of Australia and New Guinea, and, after making a voyage of circumnavigation, returned to England in November, 1850. During this period Mr. Huxley investigated, with a success known to all naturalists, the fauna of the seas which he traversed, and sent home several communications, some of which were published in the "Philosophical Transactions" of the Royal Society. The first which so appeared, presented by the late Bishop of Norwich, and read June 21, 1849, bears the title "On the Anatomy and Affinities of the Family of the Medusæ." This was, however, not Mr. Huxley's first scientific effort. While yet a student at Charing Cross Hospital, he had sent a brief notice to the *Medical Times and Gazette*, of that layer in the root-sheath of hair which has since borne the name of Huxley's Layer. Shortly after his return he was (June, 1851) elected a Fellow of the Royal Society.

In 1853 Mr. Huxley, after vainly endeavoring to obtain the publication by the Government of a part of the work done during his voyage, left the naval service, and in 1854, on the removal of Edward Forbes from the Government School of Mines to the chair of Natural

<sup>1</sup> From *Nature*. The first part of this sketch has been supplied by its editor.

History at Edinburgh, succeeded his distinguished friend as Professor of Natural History in that institution, a post which he has continued to hold up to the present day. Since that time Mr. Huxley has lived in London a life of continued and brilliant labor. From 1863 to 1869 he held the post of Hunterian Professor at the Royal College of Surgeons. He was twice chosen Fullerian Professor of Physiology at the Royal Institution of Great Britain. In 1869 and 1870 he was President of the Geological Society, having previously served as secretary. During the same period he was President of the Ethnological Society. In 1870 he filled the office of President of the British Association for the Advancement of Science, and in 1872 was elected secretary to the Royal Society. He has been elected a corresponding member of the Academies of Berlin, Munich, St. Petersburg, and of other foreign scientific societies, has received honorary degrees from the Universities of Breslau and Edinburgh, and last year was presented with the Order of the Northern Star by the King of Sweden. Since 1870 he has been one of the members of the Royal Commission on Scientific Instruction and the Advancement of Science. From 1870 to 1872 he served on the London School Board as one of the members for Marylebone, and during that time was chairman of the Education Committee which arranged the scheme of education adopted in the Board Schools. In 1872 he was elected Lord Rector of the University of Aberdeen.

In this skeleton narrative of the career of this distinguished naturalist we have purposely omitted any list or any critical estimate of his writings; but we have great pleasure in laying before our readers, as a token of what is thought of him by those who are laboring in the same field of science, the following communication from one who ranks, in his own country as well as among ourselves, as one of the very first of German naturalists.

---

The more general, year by year, the interest taken by all educated people in the progress of natural science, and the wider, day by day, the field of science, the more difficult is it for the man of science himself to keep pace with all the advances made—the smaller becomes the number of those who are able to take a bird's-eye view of the whole field of science, and in whose minds the higher interest of the philosophical importance of the whole is not lost amid a crowd of fascinating particulars. Indeed, if at the present moment we run over the names distinguished in the several sciences into which Natural Knowledge may be divided—in Physics, in Chemistry, in Botany, in Zoology—we find but few investigators who can be said to have thoroughly mastered the whole range of any one of them. Among these few we must place Thomas Henry Huxley, the distinguished British investigator, who at the present time justly ranks as the first zoologist

among his countrymen. When we say the first zoologist, we give the widest and fullest signification to the word "zoology" which the latest developments of this science demand. Zoology is, in this sense, the entire biology of animals; and we accordingly consider as essential parts of it the whole field of Animal Morphology and Physiology, including not only Comparative Anatomy and Embryology, but also Systematic Zoology, Paleontology, and Zoological Philosophy. We look upon it as a special merit in Prof. Huxley that he has a thoroughly broad conception of the science in which he labors, and that, with a most careful empirical acquaintance with individual phenomena, he combines a clear philosophical appreciation of general relations.

When we consider the long series of distinguished memoirs with which, during the last quarter of a century, Prof. Huxley has enriched zoological literature, we find that in each of the larger divisions of the animal kingdom we are indebted to him for important discoveries.

From the lowest animals, he has gradually extended his investigations up to the highest, and even to man. His earlier labors were, for the most part, occupied with the lower marine animals, especially with the pelagic organisms swimming at the surface of the open sea. He availed himself of an excellent opportunity for the study of these, when on board H. M. S. Rattlesnake on a voyage of circumnavigation, which took him to many most interesting parts of tropical oceans little investigated, previously, by the zoologist; especially the coasts of Australia. Here he was able to observe, in their living state, a host of lower pelagic animals, some of which had not at all been studied, others but imperfectly. In the Protozoa, he was the first to lead us to satisfactory conclusions concerning the nature of the puzzling *Thalassicollidæ* and *Sphærozoida*. Our knowledge of Zoophytes has been greatly extended by his splendid work on "Oceanic Hydrozoa," in which, chiefly, the remarkable Siphonophora, with their largely-developed polymorphism and the instructive division of labor in their individual organs, are described with very great accuracy.

Already in his first work "On the Anatomy and Affinities of the Medusæ," 1849, he directed attention to the very important point, that the body of these animals is constructed of two cell-layers—of the Ectoderm and the Endoderm—and that these, physiologically and morphologically, may be compared to the two germinal layers of the higher animals. He has made us better acquainted with several interesting members of the class Vermes, *Sagitta*, *Lacinularia*, some lower *Annulosa*, etc. He was the first to point out the affinities of Echinodermata with Vermes. In opposition to the old view, that the Echinodermata belong to the Radiata, and, on account of their radial type, are to be classed with corals, medusæ, etc., Huxley showed that the whole organization of the former is essentially different from that of the latter, and that the Echinoderms are more nearly related, morpho-

logically, to worms. Further he has essentially enlarged our knowledge of the important group of Tunicata by his researches on the Ascidians, Appendicularia, Pyrosoma, Doliolum, Salpa, etc.

Many important advances in the morphology of the Mollusca and Arthropoda are also due to him. Thus, e. g., he has greatly elucidated the controverted subject of the homology of regions of the body in the various classes of Mollusca. He has considered the generation of vine-fretters from quite a new point of view, based on his "genealogical conception of animal Individuality." But it is the comparative anatomy and classification of the Vertebrata which, during the last ten years, he has especially studied and advanced. His excellent "Lectures on the Elements of Comparative Anatomy" afford abundant proof of this, to say nothing of his numerous important monographs, especially those on living and extinct fish, amphibians, reptiles, birds, and mammals.

Huxley's works on the comparative anatomy of the Vertebrata are the only ones which can be compared with the otherwise incomparable investigations of Carl Gegenbaur. These two inquirers exhibit, particularly in their peculiar scientific development, many points of relationship. They both belong to that small circle of morphologists which is marked by the names of Caspar Friedrich Wolff, George Cuvier, Wolfgang Goethe, Johannes Müller, and Carl Ernst von Baer.

More important than any of the individual discoveries which are contained in Huxley's numerous less and greater researches on the most widely different animals, are the profound and truly philosophical conceptions which have guided him in his inquiries, have always enabled him to distinguish the essential from the unessential, and to value special empirical facts chiefly as a means of arriving at general ideas. Those views of the two germinal layers of animals which were published as early as 1849 belong to the most important generalizations of comparative anatomy; they already contain in germ the idea of the "perfect homology of the two primary germinal layers through the whole series of animals (except protozoa)," which first found its complete expression, a short time since, in the "Gastræa theory;" also his researches on animal individuality, his treatment of the celebrated vertebral theory of the skull, in which he first opened out the right track, following which Carl Gegenbaur has solved in so brilliant a manner this important problem, and, above all, his exposition of the Theory of Descent and its consequences belong to this class. After Charles Darwin had, in 1859, reconstructed this most important biological theory, and, by his epoch-making theory of Natural Selection, placed it on an entirely new foundation, Huxley was the first who extended it to man; and, in 1863, in his celebrated three lectures on "Man's Place in Nature," admirably worked out its most important developments. With luminous clearness and convincing certainty, he has

here established the fundamental law that, in every respect, the anatomical differences between man and the highest apes are of less value than those between the highest and the lowest apes. Especially weighty is the evidence adduced, for this law, in the most important of all organs—the brain; and by this the objections of Prof. Richard Owen are, at the same time, thoroughly refuted. Not only has the Evolution Theory received from Prof. Huxley a complete demonstration of its immense importance, not only has it been largely advanced by his valuable comparative researches, but its spread among the general public has been largely due to his well-known popular writings. In these he has accomplished the difficult task of rendering most fully and clearly intelligible, to an educated public of very various ranks, the highest problems of philosophical biology. From the lowest to the highest organisms, from Bathybius up to man, he has elucidated the connecting law of development.

In these several ways he has, in the struggle for truth, rendered Science a service which must ever rank as one of the highest of his many and great scientific merits.

No statement of the character and work of Prof. Huxley would be complete that did not recognize his remarkable attainments as a writer. All who have read the masterly papers contained in "Lay Sermons," or the "Critiques and Addresses," will acknowledge his fine and vigorous command of English, and the literary richness of his style. He has a keen enjoyment of literary excellence, and "keeps up" with poetry, fiction, and the progress of critical thought, notwithstanding his indefatigable scientific investigations. Owing to these traits, Prof. Huxley has a high reputation as a popular scientific teacher; and even his "Lectures to Working-men" are models of what such discourses should be—clear, simple, and attractive, yet carefully accurate and strictly scientific. As a public speaker he is quiet, deliberate, fluent, and, we might almost say, colloquial; while socially he is genial, witty, and brilliant. He is, moreover, a man of enlarged sympathies, in this respect contrasting markedly with many scientific men, who are swallowed up in their specialties, and never give a thought to any thing beyond them. Prof. Huxley has, however, overworked himself, and damaged his health. We hope he will regain his power, and be able to give this country a season of lecturing, as he has long hoped to do. He is perhaps the only scientific man in England who could revive for us the pleasant experience we had with Prof. Tyndall last year.

## CORRESPONDENCE.

NOTE ON THE BREEDING HABITS OF  
THE MUD-MINNOW.

OUR very common "mud-minnow" (*Melanura limi*, Agassiz — *Silliman's American Journal of Science*, 1853, vol. xvi., p. 135), which is found over a wide extent of territory in America, and which, according to Dr. Albert Günther ("Catalogue of Fishes," in the British Museum, vol. vi., p. 231), is generically the same as the *Umbra crameri* of Europe, presents some features in its breeding habits which we have thought of particular interest, and would be greatly pleased to know if the European *Umbra crameri*, which Dr. Günther states inhabits the "stagnant waters of Austria and Hungary—neighborhood of Odessa," has identical habits; or, if the difference of climate, and character of the surroundings generally, have caused a more or less noticeable variation in its habits, especially during the spawning-season. We have not access to any work, on the fishes of Central Europe, that gives any details of their habits.

As we have already described it (*American Naturalist*, vol. iv., pp. 107, 388, Fig. 86), this little umbra is, "pure and simple," a mud-loving fish, and more strictly so than any other, unless we may except the eel (*Anguilla acutirostris*). During the present winter we have had unusually favorable opportunities for studying the fish during this part of the year. In December, while the weather was cool rather than cold, with but little ice, we found that hundreds of these fish were being thrown out with the mud then being scooped from the ditches of the tract of meadow on the writer's farm. On learning this, we had the mud carefully taken out by shovelfuls and examined, to learn the exact condition and position of these fish. They were, when taken from the mud, motionless, stiff, and apparently frozen; they were not brittle, and an attempt to bend or break them resulted in a very prompt but partial restoration of vitality (or consciousness?). Specimens thus roughly handled were permanently injured by being bent, even if not in excess of a de-

gree of curvature that they can and do readily assume when in their normal condition. On placing specimens freed from mud in water of a temperature of 60° Fahr., which is pretty nearly or quite that of the ditch-water in summer, they only fully revived after lying on their sides, at the bottom of the vessel, for from twenty-five to forty minutes, and seemed to be injured permanently by the sudden change; but, if placed, with the mud still adhering to them, in water at a temperature of 40° Fahr., which became gradually warmer, by the vessel containing the fish being removed to a warm room, the minnows would become wholly themselves again, in from ten to fifteen minutes, and swim off in full vigor, as the mud slowly loosened from them and settled to the bottom of the vessel. As taken from the bottom of the ditch, the mud in which these minnows were hibernating was of about the consistency of cheese. As far as we were able to determine, these fish had burrowed tail-foremost, to a depth of from four to nine inches, and, in every instance, we believe the tail was deeper than the head, the position varying from almost horizontal to nearly or quite perpendicular.

Pursuing the investigation somewhat further, we found that, where these fishes had gone into winter-quarters in deep water, i. e., from three to five feet deep, the hibernating slumber was not as profound; and, when they were placed in clear water, at a temperature of 46° Fahr., they almost immediately swam about; slowly at first, but with steadily-increasing activity, and, in from three to five minutes, were in full possession of all their powers, and assumed the statue-like positions common to them, when seen in summer, when, for many minutes together, they will remain immovable, and only move when the near approach of an insect larva offers them a sure chance for a meal, or portion of one. It should be here mentioned that the water in the ditches from which we first gathered specimens varied from nine to fifteen inches in depth, and was coated with ice one inch thick.



During the past month (February), the weather being most of the time mild and spring-like—the smaller frogs singing throughout the day—we watched for the first appearance of these mud-minnows, and saw them in scanty numbers, first, on Sunday, the 15th. A week later (Monday, 23d), we found but few specimens in the muddy ditches, but a vast number of females, with distended abdomens, heavy with orange-colored masses of ripe (?) ova, in the swift, clear, ice-cold waters of the hill-side brooks.

On the 25th there was a violent snow-storm, with cold northeast winds, but this did not deter the "onward" movement of the minnows. Of the specimens taken from the rivulets, at this time, none were males, and it seems probable, although we could not positively ascertain the truth, that the male fish follow the females, and either seek out the deposited ova and fertilize it (does this ever happen?), or that the females wait until the arrival of the males before depositing their eggs.

We would refer, in conclusion, to one feature of their habits again. These fish, at the commencement of winter, by burrowing deeply in the mud of the waters they frequent, avoid the decided lowering of the temperature, which they, at this season, seem unable to withstand; but, at the approach of spring, they arrive, synchronously with the maturing of the ova in the females, and milt in the males, and, after thus recovering their wonted activity—say in February—no amount of severe weather deters them from seeking out exceptionally cold waters for their spawning-beds. This was shown by the late snow-storm above referred to, after which the female minnows were still found passing up the brooks, forcing their way up miniature cascades, with all the agility of a salmon, leaping from eddy to eddy, seeking out the most distant points from their muddy summer haunts that they could reach; and here, where but little water flowed, and with the dry grass and twigs projecting from it, thickly coated with crystal ice and glistening frost, we found the plainly-colored, diminutive mud-minnows hidden among the pebbles and sandy ridges of the brook-bed.

CHARLES C. ABBOTT, M. D.

TRENTON, N. J., March 2, 1874.

## ANIMAL MIGRATIONS.

To the Editor of the *Popular Science Monthly*:

I BELIEVE that grasshoppers (locusts) migrate solely on account of an enemy—a dipterous insect much resembling the house-fly, but larger, quicker, and grayish in color, owing to the white hairs at the edges of the articulations. This insect deposits its eggs in the upper part of the locust's abdomen, when the latter is resting on the ground, as it cannot do so when flying. Its favorite moment of attack is just as the locust alights from a flight or a hop. In a few days the larva or maggot is about a quarter of an inch in length. Soon the locust dies, when the larva eats its way out and burrows in the ground for transformation. Sometimes four of these larvæ will be found in one locust. I first noticed this in the summer of 1871. In 1872, when a flight of locusts began to arrive, the fly destroyed nearly all that came during the first two weeks, or until cool nights seemed to stop its multiplication. In 1873 I had an unusually fine opportunity to observe the locusts, as they hatched in incredible numbers upon my farm, and devoured my crops. During the whole summer the fly left the locusts no quiet, but drove them to most desperate straits to avoid the attacks; so that, as soon as the locusts acquired wings, they flew away—that is, what were left of them, for I estimate that not one in fifty escaped death. In places where the irrigating ditches prevented them from crawling forward, they were piled two and three inches deep. The ground during the cool of the day would be dotted with white maggots crawling off to find burrows. The locusts did not leave on account of famine, for there were ample fields of grain and other crops untouched; and they would sometimes abandon a field when only slightly eaten. Besides, I have seen the swarm floating all day in the air when still, and constantly alighting and arising, as hunger impelled from above, or the fly from below. I do not find this fly mentioned in Tenney's work on "Entomology." If comparatively new, there is hope that it will work the destruction of the locusts. I also believe the latter can be readily destroyed by the combined efforts of man, as they hatch in exceedingly small areas.

The prairie-dog (*Cynomys ludovicianus*) is migratory, although it moves slowly, accomplishing hardly more than half a mile a year. Apparently, their object is to obtain fresh food, for they eat root and branch as they go. The leaders are, invariably, the young, who are constantly driven out by their more mature and powerful brethren. Their vacated holes are occupied by owls and rattle-snakes, but whether these prove enemies or not I do not know.

I strongly suspect that the cause of migration in the lemmings is the parasites which infest their bodies. These, after a few years, increase to such numbers as to be unendurable; then the lemmings set out and are never *known* to return until they have overcome their enemies in the flood.

S. E. WILBER.

GREELEY, COLORADO, Feb. 28, 1874.

---

#### MR. SPENCER AND THE WOMEN.

SIR: Two papers have already appeared in your columns relating to Mr. Herbert Spencer's "Study of Sociology:"—a direct review of the work, January 10th, to which Viscount Amberley has given the credit of fairly appending to it his own name, thus placing his comments on the author's view of women on the true class-footing of their being the judgment of a man; and a letter, December 20th, confined to this point, to which, through its being signed only with the initial "L," class-weight of this sort is entirely wanting, notwithstanding the actual force of its remarks—thus forming, as I wish to argue, a notable instance of the undesirableness of that practice of signing by mere initials which is contended for in another article of the first-mentioned number, on the ground of its being a protection to the modest, retiring, sensitive nature of some writers who yet feel that they have something to say which would be well said. My object, then, is now the twofold one, of on the one hand repeating (with some difference) the main arguments of "L," under the avowed character of a woman; and on the other of pressing upon my fellow-women the present necessity, as especially called forth by Mr. Spencer's recent work, of women *not* indulging on this occasion in the

moral timidity which the hiding of their real names is the effect of. It is the peculiarity of the case that, as all writers have hitherto been taken for granted to be men, there has sprung a natural desire among actual women-writers to play a trick on the public, which has thence caused them as much as possible to force the matter of their own thoughts into the mould of those of men. And although, perhaps, there may be little harm in this where it is fiction alone that is concerned, I contend that it is really a deep injury in relation to those practical questions with which specially all the literature of journals must be occupied.

I share strongly with "L." the disappointment which he or she expresses on the turn which to me also appears indicated in Mr. Spencer's design *against* the present desire arisen in women to take their part in the social regulating of their country. I mean, chiefly, as to those appended statements of his, cast as if casually into the foot-notes at the end of his volume, which, however, contain in this peculiar instance what must be taken by his readers as a sort of *a priori* basis to his whole intended reasoning on the subject to come; the whole statements, crowded into almost a single page, regard matters on which it is the very claim of women that no settled opinion is yet possible. Mr. Spencer signifies that whatever fruits of the higher kind of intellect women possibly may produce are, nevertheless, by a certain degree of "normal limitation," to be accounted of as mere mental monstrosities—mere aberrations from the true course of development which is the only profitable course. He obviously thinks it nothing against such course that some of the number of *men* should exclude themselves from the ordinary duties of domestic and social life, in order that, by strained efforts at intellectual illumination, they may guide those self-efforts of commoner men, which, in the case of men, he asserts are the only true means of real culture; but with *women* he implies that all such seclusion can inevitably produce nothing of any value so long as *men* are at hand to afford the required lights. Nothing but an absolute dearth of men present to do that for women which normally they cannot do for themselves—the case referred to being

specially that of ascertaining their own social status—can justify the alleged wasting of their real powers! Surely this is a reversal of his plan for men, threatening a philosophic tyranny in his future scheme over the true instincts of women, which the latter cannot possibly feel to be justice to them.

Most needfully, then, in the face of such threatened injury on the part of a writer who is daily becoming more and more of deserved weight in social topics, must women look to one another; that is, for the openly-expressed class-feeling which manifestly is the thing that is now called for. The best thing that has been said for us by Mr. Mill, and that for which I think, for one, we owe him a debt of gratitude never to be extinguished, is that, after all, *women must speak for themselves*. Unless they will do so, this most generous of our advocates has said, it must remain "impossible that any man, or all men taken together, should have knowledge which can qualify them to lay down the law to women as to what is, or is not, their vocation" ("Subjection of Women,"

p. 48). Let me, however, add, on the other side, that in my own view this demand of self-expression from women by no means includes any equal need of immediate political action. Until the subject has been well *thought* out between men and women, with much more of careful study than is compatible with popular agitation, I am convinced that any too eager pressing forward toward practical arrangement of it must be dangerously premature. And for this end I believe truly that we need, not only all the instruction that Mr. Spencer can give us, both philosophic and scientific, but all the strenuous mental effort on the part of at least those who must take lead among us, which he seems to condemn. I recognize fully that we can in no way do better than to take him as our teacher—however little he may perhaps himself approve of this—provided always that in learning from him we remain true to ourselves.

I am, etc., SARA S. HENNELL.

COVENTRY, January 20, 1874.

—*Examiner*.

## EDITOR'S TABLE.

### THE WORK AND INFLUENCE OF THE MONTHLY.

THE present number closes the second year and the fourth volume of THE POPULAR SCIENCE MONTHLY. That it met a demand is shown by the fact that it has been better sustained than any other scientific magazine of its class that has been started in any country. That it has fulfilled its early promise in the estimation of the public, is shown also by the fact that it has been increasingly commended with each succeeding issue. We wish to make it still better, but our power to do so will depend upon the liberality of its patronage; and we therefore solicit all who would increase its strength and extend its usefulness, to do what they can to make it more widely known in their respective circles of inquiring and intelligent readers. The

MONTHLY is as yet known to but very few of those who would appreciate and prize it, and our friends can do much, as many of them have already done, by lending their copies to thoughtful neighbors, and inducing them to form clubs.

In regard to the character of THE POPULAR SCIENCE MONTHLY, we have preferred to let it speak for itself, and have made no parade of the numerous and flattering commendations of it which we have received from eminent sources. But there come a few words regarding the importance of our work from a distant country, which we may be excused for giving to our readers.

From a letter of Mr. Bancroft, American minister at the court of Berlin, to the publishers in New York, we select the following passage: "I receive from time to time your POPULAR

SCIENCE MONTHLY, which I think excellent in itself and perfectly adapted to its purpose of diffusing knowledge and a right way of thinking more widely among the people. I have done what I could to spread the knowledge of the periodical, and it is here very highly esteemed. Prof. Helmholtz and Prof. Dubois-Reymond have both spoken to me their opinions very much in its favor, and higher authority could not be found. I should not do justice to my own opinions if I did not add how well I think you deserve of the country for the persistent and judicious manner in which you employ your great influence through your business to spread through the country the important works of science as fast as they appear. In this way you give very material aid toward educating the coming generation to the love of truth and a knowledge of the world in which they live."

In the same letter Mr. Bancroft adds: "I send you to-day a copy of a masterly address of Prof. Dubois-Reymond, who, you know, stands among the highest in his branch of science: I hope you will have it translated and published in THE POPULAR SCIENCE MONTHLY. No essay of the kind since I have been in Germany has attracted so much attention, and, as you see, it has already arrived at its third edition." The address here spoken of is on "The Limits of our Knowledge of Nature." It is certainly a masterly discussion, and will appear in our next issue.

---

#### THE HIGHER EDUCATION OF WOMAN.

OF the great movement of modern culture, one of the most important phases is that now recognized as the "higher education of woman." That woman requires a better education than she has hitherto had, and that it should also be of a higher grade, are undeniable, although the prac-

tical questions that arise in the attempt to define and attain it are serious and formidable. The prevalent short-cut solution of the problem—women crave a higher education, therefore open to them the higher institutions—is as far as possible from being an adequate or satisfactory disposition of the case.

It is a constant complaint among the leaders of the woman's movement, that, in consequence of the long subjection of the sex to the domination of men, women have not been allowed or incited to think for themselves. They complain that women's ideas have been moulded by men, in conformity to the state of subordination in which the weaker sex has been held, and that the first thing women have to do is to assert themselves mentally, to develop their own powers in their own way, to form their own opinions, and not be forever dependent upon those who by the radical bias of an opposite constitution are incapable of comprehending woman or of doing justice to her capacities. On this ground it is of course impossible for woman to accept a masculine education. For the existing colleges and universities have not only been originated and developed through centuries exclusively by men, but they have been pervaded by the thoughts and animated by the feelings and tastes, and moulded by the aims and necessities, of men. If women are to free themselves from male control in the matter of one-sided mental influence, it would seem that their first care should be not to *subject* themselves to the action of those institutions the very object of which is to assimilate and determine the intellectual character of students into harmony with their own policy.

We yield to no others in the earnestness of our belief in the higher education of women; but we want to see them take the matter in their own hands, and work out a system of mental

cultivation adapted to their own natures and needs. The higher education as embodied in existing institutions cannot meet this requirement. It is, in fact, under indictment for non-adaptation to the present wants of men; and one of the most profound and important of the reforms of our age is that thorough modification of collegiate methods of study that shall bring them up to the demands of modern life. That they now answer to these demands, but very few will maintain. There are many, and the number is increasing, who do not go to college because the education there obtained is thought to be of little use to the possessor, if not indeed a hindrance to him in his future experience with the world. Thousands ignore all considerations of the usefulness of what is to be learned, and go or are sent to college because it is the proper thing, a fashion of society, and has its social benefits; and many undoubtedly go because they have been made to believe that the old education is the perfection of human wisdom for mental discipline, and is, after all, the best thing even for practical life. Yet the distrust of the system is deep, and has already made itself so powerfully felt, that the colleges have been compelled to yield to it, and in many cases to modify their methods of instruction and create supplemental schools devoted to modern knowledge. The higher education of men is thus in a state of conflict and transition; the old education is giving way, and a New Education is rising in its place.

It seems to us that this is the first fact for women to consider in their efforts to attain a higher education. The question that is forced upon men, What shall the higher education be? has even a graver concern for women, for it is not only an open one, but it is an experiment which must be submitted to the test of time, and if mismanaged may be full of peril. It behooves wom-

en not to be so carried away by the current clamor about the advantages of education, that they are willing to accept any thing under that name that is dispensed from the schools. Education, like every thing else, may be good or bad, worthless or valuable; but it differs from most other things in this, that, if bad and worthless, it cannot be got rid of. We have yet to realize the important fact that much so-called education is worse than none at all; and that it is better to leave the mind to its spontaneous forces and its self-development under the action of the surrounding influences of Nature and life, rather than to meddle with it inconsiderately, to burden it with worthless knowledge, or to violate its proportions by an extravagant over-culture of some faculties and a total neglect of others. Were the doors of all the colleges of the country to be opened to-morrow to woman, in good faith, and in obedience to a public sentiment that would lead her to avail herself of the opportunity as men do, we believe that the result could not be otherwise than in a high degree disastrous to woman and to society; and this because the education which she would get would be not what she requires, would be put in the place of what she requires, and would indefinitely postpone the attainment of what she requires.

It is well for woman that, in awakening to the necessity of a higher cultivation of her faculties, she is free in the choice of means; but it remains to be seen what she will do with her chance. There is superabounding knowledge, the ripening of all the past—wheat and chaff; there is the world's long experience with education for help or for warning; what, then, will woman do toward constructing a higher education for herself? Will she follow blindly the old traditions, content with any thing, and accept the culture that man has outgrown and is rejecting; or will she be equal to the occasion, and form



for herself a curriculum of studies suited to the requirements of her own nature?

That woman has a sphere marked out by her organization, however the notion may be scouted by the reformers, is as true as that the bird and the fish have spheres which are determined by their organic natures. Birds often plunge into the watery deep, and fishes sometimes rise into the air, but one is nevertheless formed for swimming and the other for flight. So women may make transient diversions from the sphere of activity for which they are constituted, but they are nevertheless formed and designed for maternity, the care of children, and the affairs of domestic life. They are the mothers of humankind, the natural educators of childhood, the guardians of the household, and by the deepest ordinance of things they are this, in a sense, and to a degree, that man is not. For woman in these relations, education has hitherto done but little, and humanity has suffered as a consequence. To the mothers of the race, especially, belongs the question of its preservation and improvement. The problem is transcendent, and woman's interest in it more immediate and vital than man's can be. Science has furnished the knowledge that is required, a vast mass of truth that is waiting to be applied for the conduct and ennobling of the domestic sphere. Man has originated it; is it not for woman to use it? And now, when there is so much agitation to give woman larger mental opportunities, and she is pressing for the advantages of a higher education, we have a right to expect that she will consider the subject from her own point of view, and supply the great educational need that has been so long recognized and deplored. The new departure of higher female education should unquestionably be from the results of the medical profession. We believe that physicians have by no means yet taken

the share in general education that the interests of society require; but, when the mental cultivation of women is to become systematic and they have their own higher institutions, the agency of physicians will be indispensable. It is not that all women are to be doctors, but that they are to be instructed and become intelligent first of all in the sciences of life, with which also the physician has to deal. If, to get the A. M. of Yale or Harvard, would be worth the struggle for women, as qualifying them for the intelligent fulfillment of their destiny, let the doors be battered down if necessary for their entrance; but, if it would not conduce to this end, and would rather be fatal to it, let the doors remain double-locked. If the present aspiration is to be utilized, the movement must not take a false direction. New institutions are called for, that shall supply a new education on the feminine side. The system of studies may be broad and liberal in the best sense, but what we insist on is that it should be shaped with fundamental reference to the life-needs of female students. From this point of view our existing female colleges are liable to criticism; in so far as they are imitations of the old masculine establishments, they do not meet the wants of the sex, and rather obstruct than aid the true course of feminine cultivation.

---

#### EXPERIMENTS UPON LIVING ANIMALS.

THERE is no element of human nature more noble than that sympathy with inferior creatures which leads to a kindly regard for their welfare, and protects them from wanton or careless suffering; and it is gratifying to observe that this feeling is becoming so definite, so strong, and so extended, as to have embodied itself in organizations for the systematic prevention of cruelty to animals. With all our boasted civ-



ilization and enlightenment, men are yet very much barbarians, and the cruel instincts of the savage still animate many a nominal Christian. The humaner feelings are beginning to assert their influence; but they encounter fearful odds in the struggle with hereditary impulses to violence, and that artistic refinement of brutality which seeks enjoyment in the suffering of inferior creatures.

Yet, like every thing else, the kindly sentiments toward animals may be carried to extremes and run into absurdity. We live in a world, or at least in a stage of it, in which suffering is not to be escaped. By the constitution of things, it must be inflicted. Older than the Decalogue, older than man, as old as the earliest life, is the divine ordinance of Nature to kill or be killed. The necessity of mutual destruction was instituted in the nature and with the first appearance of living things. Not only was death the doom of all, but death by violence and mutual ruthless slaughter was the necessary and normal result of the arrangement. The world has advanced through agony, and, in its unfolding, the price of higher enjoyment has ever been intenser pain. As the nervous system of the animal series has become more voluminous, delicate, and complex, the capacity of suffering as well as pleasure is increased; and, in the most perfected being, the very flowering of genius opens new susceptibilities for painful emotion of which natures with lower gifts know nothing. Pain, therefore, is not to be escaped. Each sentient creature by the law of its being strives to avoid it, and it is incumbent upon all to lessen it as far as possible, but it is wrought into the inexorable economy of things, and not to recognize and deal with it as any other fact is irrational.

It hurts insects to be killed, but we must kill them in self-defense. We destroy the lower animals for our food, but there is a deeper reason for

being rid of them, because, if suffered to multiply unchecked, they would put an end to us. It will therefore not do to yield in this matter to the pure dictates of sentiment. There is an infliction of pain that is reasonable and necessary, and one of the cases of it is afforded by the physiologist who makes painful experiments upon the lower animals to extend the knowledge of his science. As the exigencies of diet may require us to slay an ox, so the demands of scientific truth may require us to sacrifice a rabbit or a dog. In both cases the pain produced should be the least possible, but in both the ends are reasonably held to justify the infliction. Yet there have been many and earnest protests against vivisection, or experiments upon living animals, as an inexcusable cruelty; and physiologists have recently been the subjects of a fresh assault by sentimental writers in the London literary press. The arguments in favor of the practice are so convincingly stated, and the objections to it so well refuted, in a paper by Dr. Foster, of Cambridge, that we reproduce it in the present number of the MONTHLY. It will well repay perusal.

---

## LITERARY NOTICES.

ENGLISH PSYCHOLOGY. Translated from the French of Théodore Ribot,<sup>1</sup> Professor of Philosophy in the Lycée at Laval. New York: D. Appleton & Co. 328 pp. Price, \$1.50.

THE study of the human mind is beyond all doubt one of the most sublime and important, as it is certainly one of the most difficult, of all studies. So great is its interest that it has fascinated philosophers for thousands of years, and so great is its difficulty that of all branches of inquiry it has proved least amenable to investigation, and has led to the most discordant conclusions. From the beginning of speculation it has been pursued by a method that has failed to

---

<sup>1</sup> Pronounced Rebo.

yield agreement or results that have compelled the general acceptance of thinkers. Its problems were too complex, subtle, and exalted, to be effectually dealt with before men had been trained to the work of investigation on the subordinate planes of natural phenomena. The lower before the higher, the simple before the complex, must be the law of movement where not only truths of the highest order are to be reached, but the methods by which they are to be arrived at have also to be discovered. There was needed a long and severe apprenticeship of science in the work of unraveling phenomena before the realm of mind could be entered with any confidence of its conquest. And it was not only necessary to learn by scientific practice the difficult art of investigation, but the solution of mental problems was vitally dependent upon a species of knowledge which ordinary science alone could disclose. Of mind, as a phenomenon to be investigated, we know nothing whatever, except as a manifestation of organic life. It is conditioned by organic laws, and there can be no competent mental science that does not recognize this truth. Mind, moreover, is exhibited, with a thousand modifications, through all the grades of animate being, and these diversities must be regarded by any true science of the subject. The psychical natures of the quadruped, the bird, the fish, the insect, may not be so dignified as that of man, and may afford less inspiring themes for declamation, but, in a scientific point of view, they are of equal interest, and their investigation is imperative. It could not be otherwise, therefore, than that mental philosophy should be profoundly affected both by that drill in research and that extension of knowledge which have resulted from the last three centuries of scientific progress. The new phase which the subject has consequently assumed is known as the Modern Psychology or the New Psychology, and this has given rise to a school of thought, the most eminent representatives of which are Englishmen. With a few exceptions, and those of hardly the highest mark, Germany clings to the old methods. France is behind the age in every thing, our own country is crippling along after European traditions, and it is left to England to pioneer

the world in the work of psychological development.

Prof. Ribot's book is the tribute of a candid and unprejudiced foreigner to the greatness of the English school of scientific psychology, and it is an admirable analysis of the contributions of the representative English writers upon this subject. An enthusiastic student of philosophy himself, and thoroughly imbued with the scientific spirit, Prof. Ribot brings eminent qualifications to his task, and grasps the subject with the power of a master, while his work has a judicial fairness in the estimate of men that is favored by his foreign point of view. He writes, moreover, with a point and clearness that are quite unusual in treating this class of subjects. Prof. Ribot gives us in this volume a lucid account of the systems of Hartley, James Mill, Herbert Spencer, Alexander Bain, George H. Lewes, Samuel Bailey, and John Stuart Mill, and his work altogether affords the best delineation we have of the positions and grounds of the New Psychological School that has come forward into such prominence in the present generation.

Prof. Ribot prefixes to his volume an admirable and instructive introductory chapter on the relations of philosophy, science, and metaphysics, and the gradual growth and present position of scientific psychology. In his section considering the several definitions of it, he remarks as follows concerning one of them:

"We are told that psychology is the science of the *human* soul. That is a very narrow and incomplete idea of it. Is biology ever defined as the science of *human* life? Has physiology ever believed, even in its infancy, that its only object was man? Have they not considered, on the contrary, that every thing which has organized and manifested life belongs to them—the infusoria, as well as man? Now, unless we admit the Cartesian opinion of animal machines—which has no longer, to my knowledge, an adherent—we must acknowledge that animals have their sensations, their sentiments, their desires, their pleasures, their pains, their character, just like ourselves; that there is a collection of psychological facts which one has no right to subtract from the science. Who has studied

those facts? The naturalists, and not the psychologists. If we were to go further, we might show that ordinary psychology, in restricting itself to man, has not even included the whole of mankind; that it has taken no heed of the inferior races (black and yellow); that it has contented itself with affirming that the human faculties are identical in nature and various only in degree, as if the difference of degree might not sometimes be such as to be equivalent to a difference of nature; that in man it has taken the faculties already constituted, and rarely occupied itself with their mode of development; so that, finally, psychology, instead of being the science of psychical phenomena, has simply made man, adult, civilized, and white, its object.

"We have seen how psychology understands its object, let us now see how it understands its method. This consists entirely in reflection, or interior observation. Assuredly, no one believes more firmly than we do in the necessity of this mode of observation; it is the point of departure, the indispensable condition of all psychology, and those who have denied it, like Broussais and Auguste Comte, have so completely gone against evidence, and given the game to their adversaries, that their most faithful disciples have not gone so far with them. It is certain that the anatomist and the physiologist might pass centuries in studying the brain and the nerves, without ever suspecting what a pleasure or a pain is, if they have not felt both.

"No testimony is so valuable on this point as that of consciousness, and we are always brought back to that saying of an anatomist—'In the presence of the fibres of the brain, we are like hackney-coachmen, who know the streets and the houses, but know nothing of what takes place inside them.' It is also certain that the objections made to this method of observation have been very well discussed. But is it true that interior observation is the *unique* method of psychology? that it reveals every thing, that it suffices for every thing? Taken in its rigorous meaning, this doctrine would lead to the impossibility of the science. For, if my reflection apprises me of that which passes in me, it is absolutely incapable of enabling me to penetrate into

the mind of another. A more complicated process is necessary for that. We are talking; a man present at our conversation joins in it with an absent manner, says a few words with evident effort, and forces a smile; I *conclude* from all this that he is a prey to some hidden trouble. I may soon divine its causes if I have a penetrating mind, and if I am acquainted with this man and his antecedents. But this psychological discovery is a very complex operation, of which the following are the stages: perception of signs and gestures, interpretation of those signs, induction from effects to causes, inference, reasoning by analogy. It has nothing in common with interior observation except that aptitude for knowing others better which comes from knowing one's self better. Thus, one of two things is the case: either psychology is limited to interior observations, and, these being completely individual, it has no longer any scientific character; or else it is extended to other men, it searches out laws, it practises induction, it reasons, and then it is susceptible of progress; but its method is to a great extent objective. Interior observation alone is not sufficient for the weakest psychology."

INTERNATIONAL SCIENTIFIC SERIES,  
NO. VIII.

ANIMAL LOCOMOTION; OR, WALKING, SWIMMING, AND FLYING. With a Dissertation on Aëronautics. By J. BELL PETTIGREW, M. D., F. R. S. New York: D. Appleton & Co. 264 pp. Illustrated. Price, \$1.75.

LOCOMOTION by steam began but a few years since; its principles are simple, and the machines by which it is accomplished are all of one general construction; yet we have already whole libraries of literature—folios, quartos, and octavos, cyclopædias, essays, and catechisms, technical and popular—expounding and explaining it. Much also has been written in elucidation of the principles and mechanisms of progression that are illustrated in the animal kingdom; but the present volume of Dr. Pettigrew is the first popular monograph on the subject that we have seen, and, although not large, it contains much curious and interesting information upon all aspects of it. But the

chief interest of Dr. Pettigrew's book for thoughtful readers will consist in the skillful way he strikes through those diversities of movement and medium which are involved in the three forms of progression, and brings out the principles that are common to all. "We are apt," he says, "to consider walking as distinct from swimming, and walking and swimming as distinct from flying, than which there can be no greater mistake. Walking, swimming, and flying are, in reality, only modifications of each other. Walking merges into swimming, and swimming into flying, by insensible gradations. The modifications which result in walking, swimming, and flying, are necessitated by the fact that the earth affords a greater amount of support than the water, and the water than the air. That walking, swimming, and flying, represent integral parts of the same problem, is proved by the fact that most quadrupeds swim as well as walk, and some even fly, while many marine animals walk as well as swim, and birds and insects walk, swim, and fly, indiscriminately."

The problem thus becomes interesting from the unity of its fundamental laws, but for the author it has more than a speculative interest; it has a scientific importance as furnishing conditions for solving the problems of artificial progression.

Upon this point he remarks: "The history of artificial progression is essentially that of natural progression. The same laws regulate and determine both. The wheel of the locomotive and the screw of the steamship apparently greatly differ from the limb of the quadruped, the fin of the fish, and the wing of the bird; but, as I shall show in the sequel, the curves which go to form the wheel and the screw are found in the traveling surfaces of all animals, whether they be limbs (furnished with feet), or fins, or wings.

"It is a remarkable circumstance that the undulation or wave made by the wing of an insect, bat, or bird, when those animals are hovering before an object, and when they are flying, corresponds in a marked manner with the track described by the stationary and progressive waves in fluids, and likewise with the waves of sound.

"Of all animal movements, flight is in-

disputably the finest. It may be regarded as the poetry of motion. The fact that a creature as heavy, bulk for bulk, as are many solid substances can, by the unaided movements of its wings, urge itself through the air with a speed little short of that of a cannonball, fills the mind with wonder. Flight (if I may be allowed the expression) is a more unstable movement than that of walking and swimming, the instability increasing as the medium to be traversed becomes less dense. It, however, does not essentially differ from the other two, and I shall be able to show, in the following pages, that the materials and forces employed in flight are literally the same as those employed in walking and swimming."

These passages, foreshadow the character of Dr. Pettigrew's book. He works out the principles of animal locomotion as a further step in the progress of artificial locomotion, by which the theoretical issues in the practical. After an elaborate analysis of the anatomical and dynamical conditions of flight, he goes into the question of its imitation by art, and points out the conditions on which he thinks the problem may be ultimately solved. Here, of course, he launches into an untried field, abounding with difficulty, and open to a diversity of opinions. Already a brisk controversy has sprung up in the London journals over his theory of flight, and the question of precedence in its elucidation between the French and the English; but, whatever may be its merits, the interest of Dr. Pettigrew's contributions to the question in the present volume will remain unaffected. We should not omit to state that the volume is profusely and beautifully illustrated with original cuts and plates.

PRANG'S NATURAL HISTORY SERIES OF COLORED CHROMOS. For Schools and Families. Classified by N. A. CALKINS; 14 large Plates; 192 Cards. Price of full set, \$10. J. W. Schermerhorn & Co., Agents, 14 Bond Street, New York.

MR. PRANG, having achieved fortune and fame in the cultivation of the chromo-lithographic art in the department of fancy pictures, has at length turned his attention to education, and applied it to the illustration of objects of natural history. A large num-

ber of specimens of plants and animals, selected by Mr. Calkins to represent the more interesting groups of organic forms, are printed in colors upon cards for convenience of handling in the class-room. It needs not to be said that these illustrations are beautifully executed, and cannot fail to prove in a high degree attractive to children. That they have been executed with care and correctness, under the vigilant direction of Mr. Calkins, there can be no doubt. As to their utility in education, that will depend entirely upon the teacher and the policy of the school. If employed as guides to the study of real objects, they cannot fail to be helpful; but, if subordinated to the usual system of study, and accepted in place of the things they represent, they will have simply the value of excellent pictures, and will add to the already immense mass of hindrances and stumbling-blocks which the schools interpose between the minds of children and the objects of Nature.

**THE STONE AGE, PAST AND PRESENT**, by E. B. TYLOR; and **THEORY OF NERVOUS ETHER**, by Dr. RICHARDSON, F. R. S. Boston: Estes & Lauriat. Price, 25 cents.

THIS is No. 9 of "Half-Hour Recreations in Popular Science." The first paper is a popular account of the stone age, or, as the author puts it, "of that period in the history of mankind during which stone was habitually used as a material for weapons and tools." This period he divides into two parts, the first of which he calls the Underground Stone Age, when the implements employed were merely chipped out, and used in a comparatively rough and imperfect shape. Such implements are found in greatest abundance in the Drift or Quaternary Deposits, and in the early bone-caves, and consist largely of chipped flints, apparently designed for spear-heads, arrow-heads, scrapers, knives, etc. The second or later division of the period above referred to—the Ground Stone Age—is characterized by the employment of ground and often polished instruments of stone, much more perfect than the chipped forms, and therefore denoting a higher stage of human progress. Stone implements are found in nearly every part of the world, and, what-

ever their source, show a remarkable uniformity of pattern. This latter feature the author accounts for partly on the principle that man does the same thing under the same circumstances, and partly on the belief that the art was derived by one race from another. The evidences of the stone age, brought to light in the countries hitherto explored, take up the remainder of the paper. Any one wishing a general idea of what is at present known on this interesting subject, will be well repaid by a perusal of this essay.

The theory of a nervous ether we will give in the author's own words: "The idea attempted to be conveyed by the theory is, that between the molecules of the matter, solid or fluid, of which the nervous organism, and indeed of which all the organic parts of the body are composed, there exists a refined, subtile medium, vaporous or gaseous, which holds the molecules in a condition for motion upon each other, and for arrangement and rearrangement of form; a medium by and through which all motion is conveyed; by and through which the one organ or part of the body is held in communion with the other parts, and by and through which the outer living world communicates with the living man—a medium which, being present, enables the phenomena of life to be demonstrated, and which, being universally absent, leaves the body actually dead; in such condition, i. e., that it cannot, by any phenomenon of motion, prove itself to be alive." The paper is devoted to an elucidation of this theory.

**INSECTS OF THE GARDEN: Their Habits, etc.** By A. S. PACKARD, Jr. Boston: Estes & Lauriat. Price, 25 cents.

THIS is the first part of a volume from the pen of Prof. Packard, entitled "Half-Hours with Insects," to be issued in twelve parts, of about 36 pages each, by the above house. Beginning with some general considerations on the relations of living objects to one another, the author passes thence to the subject of agriculture, and the manner in which its interests are affected by the incursions of insects. Numerous instances are given of their terrible destructiveness to crops, which, though apparently insignificant when estimated, say, for



a single township, amounts to something almost incredible when an entire State or country is included in the calculation. According to the reports of Dr. Fitch, \$12,000,000 worth of wheat has been destroyed in the State of New York, in a single year, by the wheat-midge and Hessian-fly. An interesting account is next given of the reproduction, growth, and metamorphosis, of insects, with some remarks on their psychology, their relations to each other, and their relations to other animals. The last twelve pages are devoted to the insects of the garden, some of the more noxious of which are described, their habits sketched, and the means of combating them indicated. A beautiful chromo-lithograph, showing the different stages of insect metamorphosis, heads the issue, and the succeeding pages abound with well-executed illustrations. For clearness and vigor of style, the name of the author is sufficient guarantee.

**MANUAL OF PHYSICAL GEOGRAPHY AND INSTITUTIONS OF THE STATE OF IOWA.** By C. A. WHITE, Professor of Geology in the State University. Davenport: Day, Egbert & Fidler. 1873.

THIS book was made for use in the schools of Iowa, being limited to the physical geography and institutions of that State. This has enabled the author to give a large amount of information, locally valuable, that would be obviously out of place in a more general work. For convenience, the book is divided into two parts. Part I. gives an account of the leading natural features of the State—its physical geography, geology, climate, soil, minerals, and natural history. Part II. deals with the history of the State, and includes an account of its educational, charitable, and penal institutions. The few who may desire to carry the study into a wider field, will find the mastery of this work an excellent preparation.

**THE THEORY AND PRACTICE OF LINEAR PERSPECTIVE.** Translated from the French of V. Pellegrin. New York: Putnam's Sons. 51 pp., with colored chart.

THE author claims that books of this kind are generally too theoretical, and that he has aimed to make this especially practical. It was adopted by the educational authorities of Paris, and commended by

them as a "little book which, under a modest form, contains ideas of which the popularization would be of great use—'The Practical Theory of Perspective,' a study for the use of artists, etc., by Monsieur V. Pellegrin, late Professor of Topography at the Military School of St. Cyr. The author, himself a painter, and accustomed to the manipulation of geometrical methods, was particularly qualified for writing this treatise; and he has been able, by dint of research and ability, to condense into a small number of pages the laws of perspective; and to extract, from a confused mass, rules which are very simple and easily applicable to every possible case; thus placing a sure and clear guide within the reach of all students, artists, and amateurs. Monsieur Pellegrin's excellent treatise will become a standard work."

**SUBMERGED AND DIFFERENT FORMS OF RETAINING WALLS.** By JAMES S. TATE, C. E. New York: D. Van Nostrand. 1874. Price, 50 cents.

THIS is No. 7 of the publisher's "Science Series." The simple statement of what the author has proposed to himself to accomplish will be the best evidence of the value of this little manual. His object was to furnish to engineers a certain and ready means of ascertaining the pressures of embankments, submerged or otherwise, composed of different materials; also the moments of retaining walls, of different forms of cross-section, to successfully withstand those pressures. By having this little book at hand, the engineer will be saved the trouble of many a long calculation.

**HOW TO BECOME A SUCCESSFUL ENGINEER.** By BERNARD STUART. New York: D. Van Nostrand. 127 pp., 18mo. Price, 50 cents.

THIS little work, which is designed particularly for the mechanical engineer, but, in a more general way, also for the civil engineer, is more indicative than instructive. That is, it points out the studies to be pursued without explaining their nature, and it tells the apprentice what work he will find in the machine-shop, without detailing the method in which it is done. It contains some practical suggestions on the im-



portance of good habits, self-reliance, and dexterity of hand.

**LEGAL RESPONSIBILITY IN OLD AGE.** By GEORGE M. BEARD, A. M., M. D. New York: Printed by Russell's American Steam Printing-House; 42 pp., 8vo.

THIS is an address delivered before the Medico - Legal Society of New York, in March, 1873. It discusses the effects of age on the mental faculties, as evidenced in the works of the greatest men of all times. The author states that his method was to study the biographies of such men, and observe the average age at which their best works were produced. The conclusion reached is, that the best work is done between thirty and forty, the worst between seventy and eighty, and that the growth, maturity, and decay, of the mind, are coeval with the corresponding stages of the body. As a corollary, it is held that the moral faculties also decay with the downward curve of life. The fact is pointed out that one or more of the moral faculties may decay, while the rest remain sound. The address concludes with an earnest protest against the prevailing mode of testing moral responsibility in courts of law, and recommends, as an improvement, the appointment by the States of an examining commission, composed of from three to five psychological experts. It is both interesting and instructive.

**PHYSICAL GEOGRAPHY.** By JOHN YOUNG, M. D., L. R. C. S., etc. New York: G. P. Putnam's Sons. 368 pp. Price, \$1.50.

THIS book is a condensed statement of the principal geological and biological truths and such astronomical facts as relate to the earth. In the introductory chapter, the author thus describes the sphere of his subject: "Physical geography takes up the results achieved in all these departments—geology, biology, and astronomy—and proceeds to higher generalizations. It shows how the behavior of the earth, as a body in space, and its relations to other bodies, determine the atmospheric currents, and, through them, the movements of the ocean; it points out how the ocean-currents modify and are affected by the tides; it determines the extent to which the character and variation of the

climate are dependent on secular changes. The changes of sea and land, as ascertained by the geologists, are used to explain the movements of organized forms, and the biologist finds, in atmospheric, topographical, and climatal influences, the key to the presence or absence, the abundance or scarcity, of particular groups in any locality."

In connection with the composition of the earth's crust, are described the classification, formation, and chemical constitution of rocks; also the production and geological importance of fossils. The configuration of the earth's surface, or the distribution of land and water, with the changes it has undergone; the formation of islands and continents; ocean and atmospheric currents; forms of water in the atmosphere, as snow, rain, mist, etc.; climate and weather, are briefly though clearly set forth. Apparently the only fault of the book is that less space has been devoted to describing the distribution of plants and animals than the importance of the subject demands. As may be inferred from its nature, the book contains no new truths, but its value suffers no impairment therefrom. It has the merit of being free from the influence of particular theories, and, where unsettled questions are discussed, the author conscientiously endeavors to give the reader the drift of scientific opinion.

**THE BIRTH OF CHEMISTRY.** By G. F. RODWELL, F. R. S., F. C. S. London: Macmillan & Co. 135 pp., 12mo. Price, \$1.50.

THE origin of chemistry is herein traced through the grotesque alchemic vagaries of the middle ages to the natural philosophy of the ancient Greeks and their contemporaries. The quaint admixture of truth and error, constituting their so-called natural philosophy, is first shown. The ideas of primary elements and their transmutations; the metals known to the ancients and the manner in which they were worked; ancient colors and chemical compounds, are all described in a manner calculated to please the general reader. The origin of alchemy is traced to Arabia about the fourth century A. D. The mysteries of alchemy are likewise detailed, as well as the theories of combustion and phlogiston, out

of which legitimate chemistry was developed about 150 years ago, by the efforts of Boerhaave, Lavoisier, and others.

ESSAYS ON EDUCATIONAL REFORMERS. By R. H. QUICK, M. A. Cincinnati: Robert Clarke & Co. 326 pp., 12mo. Price, \$2.00.

THIS is a review of the principal educational doctrines, beginning with the once famous schools of the Jesuits, and ending with Herbert Spencer. The main features of each doctrine are given and commented on in a liberal tone. The author differs from Mr. Spencer in some important points, such as the worthlessness of ordinary history, the value of the sciences, and the position fine arts and belles-lettres should occupy in education. In the two concluding chapters he gives his own views on secular education and moral and religious training. Outlines of the lives of the earlier Reformers are given in connection with the discussion of their doctrines. The work possesses value as a history of modern education.

#### PUBLICATIONS RECEIVED.

The Border-Land of Science. By Richard A. Proctor, B. A. J. B. Lippincott & Co. 1874.

The Structure of Animal Life. By Louis Agassiz. New York: Scribner, Armstrong & Co. 1874.

A Manual of Inorganic Chemistry—the Non-Metals. By T. E. Thorpe, Ph. D. New York: G. P. Putnam's Sons.

Animal Physiology, and the Structure and Functions of the Human Body. By John Cleland, M. D. Putnam.

Politics and Mysteries of Life Insurance. By Elizur Wright. Lee & Shepard. 1873.

Inorganic Chemistry. By W. B. Kemshead. Putnam.

Addresses and Proceedings of the National Educational Association. Published by the Association. 1873.

An Elementary Treatise on Steam. By John Perry, B. E. Macmillan. 1874.

The Galvanometer and its Uses. By C. H. Haskins. Van Nostrand. 1873.

Building Construction. Putnam.

Elements of Zoology. By M. Harbison. New York: Putnam.

Bulletin of the Bussey Institution. Boston. Pp. 80.

The Progressive Ship-Builder. By John W. Griffiths. Illustrated. New York: The Nautical Gazette Print. 1874. Pp. 32.

Notice of New Equine Mammals from the Tertiary Formation. By O. C. Marsh. Pp. 12.

Twenty-second Annual Report of the Detroit Water Commissioners. 1873.

Report of the Committee on the Yellow-Fever Epidemic. Shreveport Medical Society.

Uncivilized Man. A Lecture by Bishop Cotterill, of Edinburgh. Edinburgh: R. Grant & Son. 1874. Pp. 30.

Bulletin of the United States Geological and Geographical Survey of the Territories. No. 1. Washington: Government Printing-Office. 1874. Pp. 28.

A Short Treatise on the Compound Steam-Engine. By John Turnbull, Jr. New York: Van Nostrand. 1874. Pp. 43.

#### MISCELLANY.

**Rumford's Discoveries in Thermodynamics.**—In his sketch of the growth of the science of thermodynamics, Prof. P. G. Tait, of the University of Edinburgh, rates the services of Count Rumford second in importance to those of Davy, and does not apparently consider them comparable to those of Joule. Prof. R. H. Thurston, of the Stevens Institute of Technology, in a note relating to Rumford's determination of the mechanical equivalent of heat, points out the injustice of this proceeding, on the part of Prof. Tait, and says that "we may claim for Rumford: 1. That he was the first to prove the immateriality of heat, and to indicate that it is a form of energy, publishing his conclusions a year before Davy; 2. That he first, and nearly a half-century before Joule, determined, with almost perfect accuracy, the mechanical equivalent of

heat; 3. That he is entitled to the sole credit of the experimental discovery of the true nature of heat. BENJAMIN THOMPSON, of Concord, New Hampshire, commonly known as Count Rumford, should be accorded a nobler position and a higher distinction than he has yet been given by writers on thermodynamics."

**Antiquity of Man.**—R. H. Tiddeman publishes in *Nature* an interesting paper on the "Relation of Man to the Ice-sheet in the North of England," in which he describes, with some detail, the fossils found in Victoria Cave, in Yorkshire, now being explored by a committee, aided by the British Association. In this cave discoveries of a most interesting character have been made. In a bone-bed, beneath other deposits, were found bones, teeth, and other remains of extinct species of animals. Prof. Burke identified remains of the *Elephas primigenius*, rhinoceros, cave-bear, hyena, bison, and others, and among these remains was a human bone, a somewhat clumsy fibula (small bone of the leg). Of this Mr. Busk says: "The relic is human; there is no room for the slightest doubt on the subject." And this opinion is fully confirmed by Prof. James Flower, of the College of Surgeons.

The position of the locality in which this bone was found makes its discovery of great importance. It seems to carry back the period when man existed to glacial if not to preglacial times.

**Trout from an Artesian Well.**—In the *Journal of Science and Art* we find a note from Mr. A. W. Chase, giving the following curious information, which the author received from Mr. Bard, agent of the California Petroleum Company at San Buenaventura: Mr. Bard, wanting water to supply a newly-constructed wharf at Point Hueneme, southeast of San Buenaventura, commenced sinking an artesian well on the sea-beach, not five feet from high-water mark. At the depth of 143 feet a strong flow of water was obtained, which spouted forth to a height of 30 feet. It was controlled with a "goose-neck," and utilized. One day while the agent was absent, the men around the well noticed fish in the waste water. On his return, they called his attention to the fact,

and, on examination, the well was found to be filled with young trout, thousands of them being thrown out at every jet. These trout were all of the same size (about two inches long), and perfectly developed. The first examination was made to see whether they had eyes. These were found perfect. Now, there is no stream nearer than the Santa Clara River, several miles distant. Could these fish, then, have come from its head-waters by some subterranean outlet? There are no trout in the lower portions of the stream. The temperature of the water is the same as that of the wells all around, viz., 64° Fahr., too warm, of course, for trout to live in it long.

**Atkins Charcoal Filters.**—The Atkins system of filtering water is spoken of in terms of high commendation in *Iron*, from which journal we take the following description of the system: The best and purest animal charcoal is ground and pulverized until it is brought into the finest possible state of comminution, and, thus prepared, it is mixed up with a definite proportion of Norway tar, and a compound of other combustible ingredients. The combined materials are then thoroughly amalgamated with liquid pitch, and the whole kneaded up into a homogeneous plastic mass, which admits of being moulded into slabs or blocks of any required dimensions and shape. These blocks having been allowed to dry and harden, are subsequently carbonized by being subjected to a process of incineration by heat; and, in this manner, all the combustible ingredients are burnt out of the block, leaving nothing behind but the animal charcoal in the form of a block of charcoal, permeated throughout by innumerable pores, admirably adapted for the mechanical infiltration of fluids, while subjecting them, in a minutely subdivided state, to the chemical absorptive and purifying action of the carbon itself.

These carbon-blocks are chiefly cast in cylindrical forms, so arranged that the percolation is from the external periphery inward, and the centre of the block is hollow, forming a tube whence the filtered water flows. In this way the bulk of the impurities is deposited on the outside of the block, whence it may be removed by washing with

hot water, or by scraping. Such filters, singly or in numbers, are placed in the bottom of a cistern, the central pipes of efflux being all connected together, and with one outlet. Where a large filtering capacity is required, a different principle is adopted, viz., a series of carbon-plates. In this case the water, in its passage from the inlet to the outlet, is caused to pass through a number of frames, variously constructed, according to circumstances. Thus there may be, firstly, a frame, covered with fine wire gauze; then separate frames, paneled with carbon-plates, with or without the intervention of a bed of pure loose animal charcoal, filling up the spaces between them; and there may be also a double frame, containing a sheet of felt compressed between two perforated plates, made respectively of sheet-copper and zinc, which would exert a certain electrical action, and aid in the chemical action of precipitating impurities. The system may be used for filtering the water-supply of a town.

Apart from this hygienic use, these carbon-blocks may be employed for many industrial purposes. Experiments have shown them to be efficacious in removing deleterious gases, and other soluble substances held in solution in fluids. They are applied as filters for wines, oils, and syrups; and, above all, they merit attention as an adjunct to the feed-water apparatus of steam-boilers, inasmuch as efficient filtration affords the best, cheapest, and surest method for preventing incrustation in boilers.

**Cremation.**—An eccentric will, wherein the testator requested that his body might be consumed in a gas-retort, and thus made to contribute to the enlightenment instead of the poisoning of the world, has survived the long-forgotten subject of cremation. Without doubt, Mr. Trelawney's hideously-graphic description of the burning of the body of Shelley has greatly contributed to prejudice the public mind against the cleanest and best method of getting rid of the "mortal coil." But the ceremony at Spezia was conducted in the most bungling fashion, and a want of scientific appliances contributed to the incompleteness, and, therefore, to the horror of a simple operation. A retort gets rid of the entire diffi-

culty, and, both from a utilitarian, a scientific, a sanitary, and a poetic point of view, the mausoleum, decked with cinerary urns, possesses immense advantages over the damp and unwholesome graveyard, exhaling pestiferous odors, to which modern nations, for some inscrutable reason, are preposterously wedded.—*Iron*

**Death of Dr. Forbes Winslow.**—Dr. Winslow was born in London in 1810. He began his medical studies in New York; took the degree of M. D. at King's College, Aberdeen, and became a member of the Royal College of Surgeons, London, in 1835. His first published works appeared in 1831, since which time he has made numerous important contributions to the literature of medicine, chiefly in the department of nervous and mental diseases. His most valuable work in this line, "The Obscure Diseases of the Brain, and Disorders of the Mind," was published in 1860, and has since passed through several editions. He died in London, on March 4, 1874.

**The Economy of Beer.**—Prof. Max von Pettenkofer, the eminent Munich chemist, states that, to make a quart of good beer, there is required, at least, a pint of good barley, besides hops, etc. The product contains not a single trace of albumen, and only a very small percentage of alimentary principles: in short, it is only a *condiment*, not a food-stuff properly so called. The question now arises, Would it not be better to send this barley to the mill, and make of it a bread-stuff, instead of brewing from it a costly beverage, which contributes little or nothing to the system? Or, better still, Would it not be advisable to grow, in place of barley and hops, wheat and rye, either of which would give better bread than barley?

Prof. Pettenkofer holds that the need of mere condiments is no less imperative than the need of food-stuffs, properly so called. "Butter and cheese," says he, "are neither as good nor as complete food-stuffs as milk, and yet butter and cheese are made, and will continue to be made, even though it were possible to transport milk in good condition to considerable distances." The same is to be said of barley and beer. Prof. Pettenkofer observes that

the consumption of beer is steadily increasing in spite of the advance in prices, and he is convinced that this state of things will continue, no matter what weight of argument may be brought against it. "Condiments of this kind," says he, "are often, no doubt, the occasion of real waste, but yet the majority of mankind can always, to their great profit, find, by observation and self-control, the proper amount of them to consume."

**Sensation and Motion in Plants.**—Treating of the vital phenomena which are common to plants and animals, the eminent French physiologist, Claude Bernard, observes that Linnæus's criterion of animality, viz., sensibility and mobility, is not in accord with facts. There are many plant-forms on the boundary between the animal and the vegetable worlds, for instance, the zoospores of the algæ, which have the power of motion. Then the antherozoids, particularly the œdogonium, studied by Pringsheim, manifest the faculty not only of motion in general, but even of motion toward a definite object—in other words, show all the appearances of voluntary movement. As instances of mobility in plants, the author further cites the movements of the stamina of the *Berberis* (barberry), the *Drosera*, the *Dionœa muscipula* (fly-catcher), and the oscillating sainfoin (*Hedysarum gyrans*).

Sensibility too is found in several plants. The *Mimosa pudica* (sensitive-plant) is the most prominent instance of this. This plant reacts against any irritation by folding up its leaves, which again are spread out soon after the exciting cause is removed. It is a curious circumstance that most of the agents which excite sensibility in animals have a like effect on the mimosa: thus it is affected by sudden shock, by burning, by the action of caustic, by electrical discharges, etc. Nay, the same agents, such as chloroform and ether, which deaden sensibility, or assuage pain in animals, destroy the mimosa's power of reaction. Vegetal anæsthesia is produced by the same means as animal anæsthesia.

There are other plants besides the *Mimosa pudica* which manifest this curious property of reacting against irritation, for instance, the leguminosæ of the genera

*Smithia*, *æschynomene*, *desmanthus*, *Robinia pseudacacia*, and the *Oscalis sensitiva* of India. From all this it follows that the power of movement and sensibility are functional properties which cannot strictly serve as a distinction between the vegetable and animal worlds.

**Is Sex determined by Nutrition?**—Mr. Thomas Meehan exhibited to the Philadelphia Academy of Natural Sciences specimens of the *Juglans nigra* (black walnut), with a view to showing that sex in plants is the result of the grade of nutrition, the highest grades of nutrition or vitality producing the female sex, and the lower grades the male. Examining a black-walnut tree at the flowering season, even the superficial observer will perceive three grades of growing buds. The largest buds make the most vigorous shoots. These seem to be wholly devoted to the increase of the woody system of the tree. Lower down the strong last-year shoots are buds not quite so large. These make shoots less vigorous than the other class, and bear female flowers on their apices. Below these are seen numerous small, weak buds, which either do not push into growth at all, or, when they do, bear simply the male catkins. As some naturalists hold that the feeble condition of these lower shoots is the result of their bearing male flowers, Mr. Meehan invited attention to the specimens themselves as conclusively proving the contrary. He was fully satisfied that any one, who would go out into the woods and fields for facts fresh from Nature, would see that there is not so great expenditure of vital force in the production of male flowers as there is in that of female flowers, and thus all he had advanced on this subject was fully sustained.

It will be remembered that, in our June number, we recounted the observations of Mrs. Mary Treat on the subject of controlling sex in butterflies, from which it appeared that butterfly-larvæ developed into male or female butterflies according as they were stinted in food, or liberally supplied with it. Besides the very interesting observations of Mr. Meehan, we have now further confirmation of Mrs. Treat's results in a paper communicated to the Philadelphia Academy by Mr. Gentry. The latter author, in the sum-



mer of 1871, had confined the larvæ of various species of moths, and neglected to supply them with food for four or five days. These larvæ had advanced toward their final change, possibly within a week or ten days. When the box was opened, the greater number were found in cocoons, while the remainder wandered about, as if in quest of food. The latter the author removed to another box, where they were provided with abundance of food. After three or four days they began to assume the chrysalis form. The first batch proved to be males without exception, while the last batch proved, with but two exceptions, to be females. (The whole number in the two batches was about sixty.)

Mr. Gentry then details further experiments made by him to decide this question, and states that the result was always the same. He adds the following facts, which came under his notice in the course of his observations and experiments: 1. That males are the invariable result when the larvæ are fed on diseased or innutritious food; 2. That in the fall, when the leaves have not their usual amount of sap, males are generally produced; 3. That more males are produced late in the season than females; 4. That the sexes, in early life, cannot be distinguished, the change being brought about, late in life, by the conditions of nutrition.

**Intensity and Patience required in Scientific Work.**—Whether in original work or in elaborating work already done, scientific labor, when conscientiously performed, is necessarily slow and exhausting. M. de Candolle, the great French botanist, has recently brought to a conclusion, with the seventeenth volume, his great "Prodrome of Plants," stopping at the completion simply of the *Dicotyledones*. It was begun by his illustrious father, Augustin Pyramus de Candolle, about 1816, who worked at it until his decease, in 1841. It was continued by his son Alphonse, who called to his aid other famous botanists, his son Casimir among them. With true *naïveté* the author pleads necessity of stopping at the point now reached—" *ne tertiam botanicorum generationem occideret!*"—lest the undertaking should kill off a third generation of

botanists. In a supplemental pamphlet he gives his opinion that the Phanerogams, estimated at 110,000 species, might, by distributing the task among twenty-five botanists, be worked up in about fifteen or sixteen years. He says that in his father's time one could elaborate at the rate of ten species a day, but that now a faithful monographer (or specialist), under the modern requirements, can seldom exceed 300 or 400 species per annum—that is, about one species a day!

**Rationale of Double Flowers.**—That the tendency in plants to produce double flowers is a natural one, and not exclusively evoked by the florist, is shown by Mr. Thomas Meehan, in a communication to the Philadelphia Academy of Natural Sciences. Many of the commonest wild flowers, which no one would think of cultivating, have double flowers in cultivation, which were no doubt originally found wild; for instance, various species of *ranunculus*. The author had himself placed on record the discovery, wild on the Wissahickon, of a double *Saxifraga Virginica*, and Dr. James Darrach had found in the same location a double-trailing arbutus. There are in plants two methods by which double flowers are produced. The axis of a flower is simply a branch very much retarded in its development, and generally there are, on this arrested branch, many nodes between the series forming the calyx, or corolla, and the regular stamens and carpels, which nodes are entirely suppressed. But, when a double flower is produced, sometimes these usually suppressed nodes become developed, in which case there is a great increase in the number of petals, without any disturbance in the staminal characters. But, at other times, there is no disturbance of the normal character of the axis. This was the case with the trailing arbutus discovered by Dr. Darrach.

**Land-Plants in Lower Silurian.**—It has hitherto been supposed that the Silurian age was one in which an absolutely unbroken ocean enveloped the earth. Dr. Dawson made it probable that land-plants existed in the Upper Silurian, or latter Silurian age. Leo Lesquereux, in *American*



*Journal of Science and the Arts*, has well-nigh demonstrated that dry land existed in the Lower Silurian age. He communicates the discovery of two small specimens representing branches or small stems of a species referable to *Sigillaria*, and found on Longstreet Creek, near Lebanon, Ohio, in clay-beds positively referable to the Cincinnati group of the Lower Silurian. With the exception of these Lebanon specimens, the geological formations of the United States have not afforded as yet any records of plants earlier than those of the Lower Devonian.

**The Uses of Bees' Wings.**—At the late Convention of Bee-Keepers at Louisville, D. L. Adair read an essay on the various uses of the bee's wings, in which he holds that, besides flying, the wing of the bee serves two or three other important ends. The horny frame, upon which the fine membrane of the wings is stretched, is composed of hollow tubes of a hard substance called *chitine*. These tubes are double, being one tube inside of another. The inner ones are extensions of the *tracheæ*, through which the air circulates in breathing; between this and the other tube is a space through which the blood circulates. The blood is brought in contact with the air through the thin walls of the air-tubes, just as the air and blood are brought together in the human lungs, and with the same effect.

The nervous filaments in like manner pass to the wings; they follow the respiratory tubes and all the fine venations of the wing, terminating in every part of its surface in papillæ, which in all animals are the vehicles through which sensations are perceived. Hence we may infer that the wings are the organs of some sensation. Are these nerve-filaments intended merely for noting tactile sensations? Mr. Adair is of the opinion that by means of them the bee is made conscious of odors. "Some naturalists have suggested the antennæ as the organs of smell; but, as they appear to be poorly adapted to perform such an office, it is just about as likely that they smell with them as that they see with them. Invisible particles emanating from odorous bodies, coming in contact with the olfactory nerves, produce the sense of smell.

These atoms are mixed with and floating in the air, and, in order to collect them, a considerable volume of air must be made to pass over their surfaces—a thing which the wings certainly accomplish in an eminent degree."

The sense of hearing in bees has never been localized by naturalists, though some have supposed that the antennæ are the organs of this sense also. "What appendage of the bee," asks Mr. Adair, "would be better suited to receive sound-vibrations than the thin, stiff membranes composing the wings?"

**The Lignite-Beds of the Rocky Mountains.**—The opinion having been advanced that the so-called lignite-beds of the Rocky Mountains have been formed by the heaping of drifted materials, and not by growth *in situ*, Mr. L. Lesquereux replies as follows, in *Silliman's Journal*, to one of the arguments urged in favor of the opinion—viz., that the *under-clays* of the lignite-beds have no roots: "I can say," he writes, "from repeated and personal observations, that most of the lignite-beds of the West, which have passed under my examination, have the under-clays full of rootlets or of roots of the floating plants, which were the first, generally at least, to contribute to the formation of the bed of combustible material by their *débris*. At the Raton Mountains, at Cañon City, at Gehrung's, near Colorado, at Golden, Marshall, Black Butte, etc., the coal is everywhere underlaid by chocolate-colored shale, often a compound of these roots or rootlets, so compact, indeed, that they cannot be determined, nor their forms distinctly recognized. Of course, the under-shales do not contain any roots (true roots of trees); the coal of the carboniferous, too, never has any, for the good reason that trees do not grow in water, and that they only invade peat-bogs when the ground is solid enough to support them. And even then the roots grow horizontally, and do not descend deep into the matter which, generally impregnated by water, is to a degree inaccessible to atmospheric influence.

The so-called roots of the clay-beds of the carboniferous measures, or the *Stigmæria*, are not roots, but floating leaves. And even their cylindrical stems are rarely

found in clay-beds; only their leaves fill them just as the radicles of water-plants fill the clay of the Tertiary lignite. It is, however, a fact that some of the lignite clay-beds, and those of the coal-measures, too, are clean or without admixture of vegetable remains, even of rootlets. But when the peat is beginning its growth at the surface of a somewhat deep basin of water, whose bottom has been rendered impermeable by the deposit of clay (which always precedes the deposit of woody materials), this surface-peat is often thick and compact before it is forced down and comes in contact with the clay; and, in that case, therefore, the clay is pure, or is not penetrated by roots or rootlets. There are, of course, some beds of impure lignite, whose origin is due to drifted wood, especially along large rivers. One is known at the mouth of the Rhone, in France. I have seen some deposits of the kind in Southeastern Arkansas, near the Wachita River. The great Red-River obstructions may become in time lignite-deposits. But all formations of this kind show their origin by their composition, viz., sand mixed with carbonized matter, sandy bottom, perforated, too, in various directions by drifted stems, etc. Nothing of this kind has been observed in the beds of lignite of the West, at least not in those which have come under my examination."

**Geology of the Land of Moab.**—Late explorations in the land of Moab by Dr. Tristram have disclosed some interesting geological features in that region. The doctor's observations were mainly confined to the highlands, which are in reality a set of terraces, or table-lands, rising to the eastward from the shores of the Dead Sea—attaining, in a distance of 35 miles, a height of between 4,000 and 5,000 feet. These table-lands are cut at right angles into deep gorges or ravines, by streams which now flow, or at some former time have flowed, westward into the Dead Sea. Some of the gorges are 1,800 feet deep, with perpendicular walls, from which a good idea of the geological structure of the region may be obtained. The surface of these highlands is composed of chalk, which rests upon a limestone formation, regarded by some as nummulitic and by

others as Jurassic. The chalk and limestone together are from 1,200 to 1,500 feet thick. The limestone is supported by new red sandstone, the line where they join being well defined. It is from this line of junction that the hot springs, so celebrated in Roman times, gush forth. The water of these springs has a temperature varying from 100° to 143° Fahr. The salt-hills at the south of the Dead Sea, like the table-lands just spoken of, have been gouged out by the action of water, and present along their face numerous columns and pinnacles of salt, that are being rapidly worn down by the action of the weather.

**Etiology of Typhoid Fever.**—Prof. I. Buckman writes to the *Gardener's Chronicle* concerning the discovery of a microscopic fungus in water, the drinking of which was suspected of developing cases of typhoid fever. We give the main points of this communication. Some years ago Prof. Buckman examined the spout of a pump which had supplied water to a family attacked by typhoid. It was found to be lined with gelatinous matter. Under the microscope this substance was seen to contain some elegant branched confervoid or fungoid growths, intermixed with which were minute ovoid cells. As these fungoids require nitrogen for their nourishment, the author inferred that the supply came from some neighboring cess-pool. He next went to the exit-drain of the town sewerage, and there found bits of sticks, leaves of water-plants, and the like, more or less covered with this same gelatinous matter.

The author next detected this fungus in water used by his own family, some of whose members were severely attacked with typhoid fever. A defective drain in the neighborhood of the dwelling having been set to rights, and the whole of the water pumped out, the water has since been of excellent purity. Having cited two other analogous cases, Prof. Buckman speculates as follows on the mode in which this fungus acts after having been admitted into the animal economy: "How it acts it would be difficult to determine, but it is at least conceivable that the spores of the fungus may get into the circulation, and bring about changes in the fluids, after the manner of

yeast in beer; and, if so, the seeds of the fungus would be likely to develop rapidly, if they came in contact with milk, or water containing nitrogenous matter. 'A little leaven would leaven the whole lump,' and, as it appears to me, in this way much disease may be accounted for. The microscope, then, will enable us to make out the presence or absence of this fungoid or confervoid matter in foul water, and my own observations confirm me in the view that, being present, it is highly dangerous, and, if its cause can be removed, and the water made pure, all danger from this source at once ceases, while if it cannot it should be at once disused, and pure water be sought for elsewhere."

**A Sun-driven Engine.**—G. A. Bergh, writing in Poggendorff's *Annalen*, on the application of solar heat as a motive power, says that the engine which is to serve for this purpose must employ some liquid with a very low boiling-point. There are several such liquids—sulphurous acid, methylic chloride, methylic ether, etc. Of all of these, sulphurous acid best deserves attention, as it has several useful properties for the end in view. It is not too difficult to condense, and it can be got at a moderate price. Now we have got the principle on which we must construct our solar engine. Conceive a vessel, filled with sulphurous acid, exposed to the sun's rays; the tension of the sulphurous-acid vapor, if the temperature of this vessel *A* exceeds that of the surrounding air by at least 10° to 20°, must be from one to three atmospheres higher than that of the sulphurous-acid vapor in another vessel, *B*, similarly filled with sulphurous acid, but which has only the temperature of the surrounding air. We can thus arrange an engine which agrees in principle with the steam-engine, with merely this difference, that the water is replaced by sulphurous acid, and the fuel by the solar heat; while the vessel exposed to the sun's rays represents the steam-boiler, the vessel kept at ordinary temperature may represent the condenser. The sulphurous acid condensed, after doing work in the vessel *B*, could easily be driven back, by a force-pump, into the vessel *A*. The capability of work of such a machine must naturally increase with the

amount of heat communicated to vessel *A* or be proportional to the surface exposed to the solar rays.

An establishment, furnished with a machine like this, might carry on its work while there was sunshine, but, in default of this, would be brought to a stand-still. True, the solar heat might be replaced by the heat of the air, if the temperature of the air were pretty high, and one had at hand a refrigerating substance like ice. But, as this is not always the case, the establishment should have, besides the sun-machine, an apparatus which might "store up" some of the work done by this. As such, Natterer's apparatus for condensing carbonic acid might be used. If a supply of carbonic acid were kept in a large gasometer, the Natterer apparatus might be fed from this. In a wrought-iron vessel, thus filled with liquid carbonic acid, we should thus have an enormous store of mechanical force, which might be made to replace the action of solar heat in the sun-machine, partially or wholly. After work done, the carbonic acid, become gaseous again, might be collected in the gasometer. Or, again, the sun-machine, while in action, might drive an ice-machine, and might, in default of sunshine, profit by the ice it had produced, for maintenance of its working.

**The Movements of Drosera.**—Prof. Asa Gray, commenting in the *American Journal of Science* on a paper by A. W. Bennett, on the movements of the glands of *Drosera* (*sundew*), remarks that the author's description of these movements does not do justice to the facts, as observed by Dr. Gray himself. Mr. Bennett observed not only the bending in of the glands upon the body of the insect which lights on its leaf, but that "the sides of the leaf had also slightly curved forward, so as to render the leaf more concave." With us, says Dr. Gray, the leaves do much more than that. As well in *Drosera rotundifolia* as in *D. longifolia*, the end of the leaf folds over upon the base, or nearly like a shut hand, thus fairly inclosing the captive insect.

He adds that, when Mrs. Treat's account of this infolding of the leaf was published, in 1871, the discovery was thought to be new. But he has since found that the in-

folding of the leaf, as well as the intrusion of the glands, was discovered by Roth in 1779. The only real addition to our knowledge—this old knowledge, recently reproduced—is that contained in the latter part of Mr. Bennett's communication, which is to the effect that *Drosera* acts upon bits of raw meat just as upon a living insect, but is motionless toward inorganic bodies, and, in his experiments, to bits of wood and of worsted. In the published report of the communication no allusion is made to the history and record of all these discoveries, but Prof. Gray claims for Mr. Darwin the credit of having been the first to discover this difference of behavior of the drosera-leaf to different substances. He says that there are other still more curious observations and experiments of Darwin's upon *Drosera* and *Dionæa*, which it is hoped will soon be published.

**Ocean-Steamships.**—A writer in the *Evening Post* notes some of the principal shortcomings of the ocean-steamship of the period, and offers some practical suggestions as to the proper construction of a passenger-steamer. The ocean-steamer of to-day is simply a huge freight-boat. She is somewhat larger, and perhaps a trifle swifter, but certainly not any safer, than when she first crossed the Atlantic some thirty years ago. It would seem absurd if our railroads had no passenger-cars, and we had to travel about the country strapped on to the roof of a freight-car. Ocean-travel is quite as absurd, and even more dangerous, for our tier of state-rooms is strapped to the top of a heavy iron box, loaded with heavy freight, which, in the event of a sudden blow, goes to the bottom as if it were made of glass. According to the writer in the *Post*, the passenger-steamship should be of about the same length as at present, but broader and shallower, with lines adapted, not to carrying capacity, but to speed; the chief novelty, however, being that the entire hull, excepting the spaces required for engines and coal, would be filled up with very small air- and water-tight compartments or cells—enough to make the ship a gigantic life-preserver. All the state-rooms and quarters would be on the main-deck. The cellular construction of the vessel would add great-

ly to her strength, while her lightness would admit, at least in ordinary weather, of great speed, and her model would greatly diminish the rolling so provocative of sea-sickness.

As regards the question of expense, while the first cost and daily outlay would not exceed those of the present style of steamer, the passenger-steamer could make twice as many trips in the year, for she would not only be actually faster, but would save much time between voyages which is now spent in discharging and receiving cargo; for the same reason, after landing her passengers, she could start again in a day or two on another trip. Such a vessel might be disabled by collision, but it is hardly possible that she could be sunk by any form of accident that we are familiar with.

**Tarantism.**—Tarantism is the title given by physicians to an epidemic nervous disorder which prevailed in Italy, and more particularly in Apulia, during the middle ages. It was supposed to be caused by the bite of the tarantula, a species of spider found in Southern Europe, and very plentiful in the vicinity of the city of Taranto, whence it derives its name. The disorder, whether caused in the first instance by the bite of this spider or not, was capable of passing from subject to subject by a sort of sympathy, and thus the affection would spread to hundreds and thousands of the population, without distinction of sex or age. Analogous nervous diseases, known as St. Vitus's dance, or St. Guy's dance, prevailed in Germany, France, and England. A recent writer on "Mental Disease," W. A. F. Browne, gives the following account of these singular affections:

"In all these affections," says he, "which spread over great masses of the population, Teutonic and Celtic, children and octogenarians alike, there were observed wild and exuberant excitement, delusion, and antipathies, with uncontrollable impulses to run or leap, all such movements ultimately passing into dancing, which was generally aggravated, though sometimes mitigated, by music. These dancers were impelled sometimes by imitation, sometimes by fanatical exaltation, sometimes by terror and the fear

of being poisoned, and it was when under the latter emotion that harmony seems to have been most powerful and curative. *Airs (tarantelle)* have been preserved which were employed in arresting or moderating the frenzied rotations and leaps of those urged on by dread of the bite of the tarantula, and by other causes; and that some interference was required is evident, for, although large numbers of those affected recovered, many resisted all coercion, and danced themselves to death."

The tunes which were regarded as remedial are said to have been of peculiar character, and to have contained transitions from a quick to a slow measure, and to have passed gradually from a high to a low key. The sensibility to music was so great that, at the very first tones of their favorite melodies, the affected sprang up, shouting for joy, and danced on without intermission until they sank to the ground exhausted and almost lifeless. Although thus excitable, no external or audible music was requisite to suggest or sustain such movements. Apparently stimulated by some internal rhythm, the performers danced, sometimes with infuriated, but always with measured steps, wheeling hand-in-hand in circles, not merely from street to street, but from town to town, dropping down when exhausted, but having their places supplied by fresh recruits. When under this inspiration, the rudest of the victims exhibited gracefulness in dancing, and manifested displeasure when false notes were introduced into the music.

**Utilization of Sewage.**—The following facts, with regard to the utilization of the sewage of the city of Paris, are taken from the official returns: At Clichy, a bend of the Seine forms a sandy, level peninsula, of some 5,000 acres. The barrenness of this peninsula is proverbial, and hence it was on this land that a portion of the city sewage was first directed, with a view to put the utility of this kind of fertilization to the severest possible test. The preliminary works were begun in 1868, and completed in May, 1869. From that time between 5,000 and 6,000 cubic yards of the sewage have been raised daily by engines of 40-horse power and centrifugal pumps, and of this two-thirds were received into tanks for

chemical manipulation, the remainder being applied to a piece of land 12 or 15 acres in extent. At the end of several months the results of this experiment upon a naturally poor soil were such that the neighboring farmers asked to be included in the benefits derived from the sewage. Owing to the extreme permeability of the soil, 20,000 cubic yards of sewage could be annually absorbed per acre, and the farmers obtained crops of 70,000 lbs. of cabbages, 60,000 lbs. of carrots, and 150,000 lbs. of turnips. All land suitable for irrigation rose in value. No evil effects on the health of the inhabitants could be detected, and a village sprang up around the works. A Parisian perfumer established his manufactory on the outskirts of the irrigated land, and obtained a supply of the sewage-water for his gardens of aromatic herbs, more especially of peppermint. It is worthy of note, in this place, that the finest mignonette of Covent-Garden Market, London, has long been grown from sewage-irrigated soil.

---

## NOTES.

**AN HONOR TO PROF. HENRY.**—Prof. Joseph Henry, secretary of the Smithsonian Institution, has received from the French Government a superb porcelain vase, as a testimonial of his services as the United States representative of the commission on the international standard metre.—*Journal of the Telegraph.*

**NEW FOSSIL MAN.**—In the *Revue Scientifique* for December, it is stated that a third skeleton of a troglodyte has been discovered by M. Rivière, in the caves of Mentone. This new skeleton, judging from the various and numerous implements by which it was surrounded, lived at an epoch far more remote than that assigned to the skeleton now in the Museum of Paris. The instruments of warfare and other objects found with it, though composed of flint and bone, are not polished. They are only sharpened, and, by their coarse execution, appear to belong to the palæolithic age. On the upper part of the skeleton was a large number of small shells, each pierced with a hole, which appeared to have formed a collar or bracelets. No pottery nor any bronze object was found.—*Lancet.*

In an article on "Furs and their Wearers," published in the December *POPULAR SCIENCE MONTHLY*, the fur-seal of Alaska and the sea-otter were inadvertently confounded. In a letter kindly calling atten-



tion to the error, Mr. F. M. King, of White-stone, L. I., who has been on the spot and knows the two animals, points out a few of their characteristic differences. The sea-otter is rarely seen on land, but eats, sleeps, and is said even to bring forth its young in the water. It is provided with a tail, has legs with webbed feet, and handles its food with its fore-paws, and is in fact an *otter*. The fur-seal breeds on shore, and is captured mostly out of the water. It has neither legs nor paws, but flippers like all the other *seals*.

THE death of the great German anatomist, Max Schultze, is announced. He was in the prime of life, and had just experienced the satisfaction of seeing his laboratory at Bonn—the amplest and most elegantly-constructed in Europe—finished, under his direct supervision. His death is a great loss to biological science.

A WRITER in the *American Naturalist* suggests that one of the most important uses to which the Yellowstone National Park can be put is, “the preservation from extinction of at least the characteristic mammals and birds of the West, as far as they can be domiciled in this section.”

A GERMAN engineer proposes to combine hard ingots, or blocks of steel, in the process of casting, with laminae of soft steel or wrought-iron, in such a manner that the latter, in undergoing the rolling process, may assume an internal position, thus combining a certain amount of elasticity, ductility, and toughness, in the interior, with a hard exterior to withstand wear and abrasion.

A CEMETERY is now being searched at Luzarches, in the vicinity of Paris, where articles of the times of polished stone have been found. Hatchets, knives, scissors, arrow-points, and delicately-worked blades, made of flint, have been discovered; also awls of bone from various animals; and, on the remains of a female skeleton, a kind of medallion with two holes was seen, which probably formed part of a necklace. Several skulls have been examined by Dr. Broca, who will communicate the results of his investigations to the Anthropological Society of Paris.

It is stated that, at the recent Scientific Congress at Rome, two Neapolitan physicians submitted to the meeting a liquid preparation for stopping instantaneously the flow of blood from wounds of every description. A commission of physicians have performed experiments with it in one of the Roman hospitals, and have reported on it as one of the happiest of recent discoveries, and as particularly serviceable on the field of battle.

A CURIOUS addition was lately made to the aquarium of the Paris Jardin d'Acclimatation, viz., a polyp of the Medusa kind. The day after its admission to the compartment assigned to it, all the other animals in the same tank were found to be dead. An analysis of the water showed the reason of this strange mortality—the polyp had changed the water to vinegar. The so-called vinegar-polyp has the power of producing in itself alcohol, which is soon transformed into vinegar; this, however grateful it may be to the polyp that produces it, is fatal to other aquatic creatures. The poisonous Medusa was at once removed from the basin and put in a tank by itself, where it will be permitted to carry on its cheap vinegar-manufacture as long as it pleases.

AN exhibition of appliances adapted to economize fuel is to be held in Manchester, England. The exhibition will comprise: 1. Appliances which may be adapted to existing furnaces, etc., whereby an actual saving is effected in the consumption of fuel. 2. Appliances which may be adapted to existing furnaces, etc., whereby waste heat is utilized. 3. New steam-generators and furnaces, boilers and engines, specially adapted for saving fuel, and appliances whereby waste products are utilized, the radiation of heat prevented, etc. A variety of similar apparatus for manufacturing, agricultural, and domestic purposes, will also be exhibited. The exhibition promises to be interesting and instructive.

AN institution of novel character was recently founded in France. The Villa Emilia, at Meudon, half-way between Paris and Versailles, was thrown open on January 1st, to explorers of any nationality, to young men who propose making scientific voyages, and to all who wish and are able to encourage them. The expenses of the institution are to be defrayed by an association. The property already embraces instruments and laboratories, scientific books, etc. Free courses and lessons will be given, and travelers may leave their collections there, to be kept till their return. Gifts of money will be made to those who may serve the society in certain specified ways. The association, “Cercle des Explorateurs,” as it is called, will have its Gazette, giving news of explorers, and there will be two meetings, in spring and fall. Those wishing to join the society are desired to communicate with its originator, M. Méhédin, Meudon, Seine-et-Oise.

DR. FERRIER has received a grant from the Royal Society, for the purpose of enabling him to pursue his investigations on the brains of monkeys, etc. The results of his researches will, in due time, be embodied in a paper which will be read before that society.



# INDEX.

	PAGE
ÆSTHETIC Sense in Animals.....	729
Agassiz, Prof. Louis R., his Death.....	495
“ “ “ Autopsy of.....	633
“ “ “ Biographical Notice. (Portrait).....	608
“ “ “ His Successor.....	637
Age, The, of Ice. (Illustrated).....	641
Alchemy, its Future.....	602
Alcohol.....	381
Alternations in the Intensity of Diseases.....	569
Ancient Well in Illinois.....	252
Animal-like Functions of Plants.....	382
Animals, The Æsthetic Sense in.....	729
Antioch, Rebuilding of.....	126
Ashes, Leached, as a Fertilizer.....	509
Asphaltum in West Virginia.....	636
Atmospheric Electricity and Ozone.....	456
Baryta, Uses of.....	638
Beer, Economy of.....	760
Bees' Wings, Uses of.....	763
Body and Mind, Relations of.....	111
Books noticed :	
“ Civilization considered as a Science ” (by Harris).....	118
“ Chronos: Mother Earth's Biography ” (by Wood).....	249
“ Conservation of Energy ” (by Balfour Stewart).....	627
“ Elements of Physical Manipulation ” (by Pickering).....	117
“ Philosophy of Evolution ” (by Lowne).....	116
“ Workshop Appliances ” (by Shelley).....	122
“ Logic of Accounts ” (by Folsom).....	118
“ Antiquities of the Southern Indians ” (by Jones).....	119
“ Man and Apes ” (by Mivart).....	630
“ Dictionary of Medical Science ” (by Dunglison).....	630
“ Theory of Evolution of Living Things ” (by Henslow).....	503
“ The New Chemistry ” (by Cooke).....	500
“ International Review.”.....	500
“ The Bible and the Doctrine of Evolution ” (by Smythe).....	503
“ Sex in Education ” (by Clarke).....	377
“ Religion and Science ” (by Le Conte).....	502
“ Our Common Insects ” (by Packard).....	247
“ Descriptive Sociology ” (by Spencer).....	504
“ Autobiography of John Stuart Mill.”.....	376
“ British Marine Algæ ” (by Grattann).....	378
“ Proportions of Pins used in Bridges ” (by Bender).....	248
“ Comparative Anatomy of the Domesticated Animals ” (by Chauveau).....	246

Books noticed :	PAGE
“Statistics of the World” (by Schem).....	631
“Geological Survey of Ohio.”.....	374
“Origin and Metamorphoses of Insects” (by Lubbock).....	628
“Henslow’s Botanical Charts” (by Youmans).....	628
“On Intelligence” (by Taine).....	629
“The Atmosphere” (by Flammarion).....	245
“English Psychology” (by Ribot).....	751
“Animal Locomotion” (by Pettigrew).....	753
“Prang’s Natural History Series of Colored Chromos”.....	754
“The Stone Age” (by Tylor).....	755
“Insects of the Garden” (by Packard).....	755
“Manual of Physical Geography” (by White).....	756
“Retaining Walls” (by Tate).....	756
“Legal Responsibility in Old Age” (by Beard).....	757
“Physical Geography” (by Young).....	757
“The Birth of Chemistry” (by Rodwell).....	757
“Essays on Educational Reformers” (by Quick).....	758
Botany, Tennyson and.....	193
Brain and Mind.....	253
Brain, A New Method with the.....	183
British Association.....	114
Carboniferous Strata, their Constitution.....	508
Caterpillars.....	381
Chemistry of the Rocks, what it teaches.....	694
Chromosphere, The, and Solar Prominences. (Illustrated).....	385
Coal-Fields of China.....	250
Colorado, The Great Cemetery in.....	470
Concerning Serpents. (Illustrated).....	257
Constellation, Past and Future of a. (Illustrated).....	291
Constitution of Carboniferous Strata.....	508
Cooling and Contraction of the Earth’s Crust.....	255
Correlation of Vital with Chemical and Physical Forces.....	156
Correspondence.....	633, 744
Corundum.....	452
Cremation.....	760
Cryptograph.....	125
Czermak, Professor.....	115
Dead, Disposal of the.....	592
De Candolle’s Great Work.....	762
Dental Plates, New Material for.....	507
Descent of Man.....	251
Disposal of the Dead.....	592
Dissipation of Energy.....	430
Draper, Dr. J. W., Sketch of. (Portrait).....	361
Drosera, Movements of.....	765
Education, Liberal, in the Nineteenth Century.....	1
Education, Scientific, Requirements of.....	208
Education, Higher, of Women.....	748

	PAGE
Electric Signaling .....	581
Emotional Language of the Future .....	319
Energy, Dissipation of .....	430
England and America .....	631
Evolution and the Origin of Life .....	713
Evolution, Genesis, and Geology .....	324
Explosion of a Powder-Mill .....	231
Experiments on Living Animals .....	750
Eyes, Unequal Power of the .....	379
Facial Angle. (Illustrated) .....	587
Feather, A (Illustrated) .....	686
Fish, Subterranean .....	639
Flowers, Double, Rationale of .....	762
Forces, Correlation of Vital, with Chemical and Physical .....	156
Freak of Nature. (Illustrated) .....	448
French Association for the Advancement of Science .....	125
Furs and their Wearers. (Illustrated) .....	143
Future of Alchemy .....	602
Genesis, Geology, and Evolution .....	324
Geographical Work, A Year of .....	735
Gladstone and Spencer .....	492
Glycerine, Tests for .....	510
Grafting, Natural .....	380
Grape-vine Blight .....	381
Great Cemetery in Colorado .....	470
Growth and Decay of Mind .....	328
Growth of Salmon. (Illustrated) .....	27
Haeckel's Moners. (Illustrated) .....	181
Health and Comfort in House-building .....	69
Hedge-Plant, A Good .....	635
Heredity, Phenomena of .....	55
Heredity and Race-Improvement .....	170
Hooker, Dr. J. D., Sketch of. (Portrait) .....	237
House-building, Health and Comfort in .....	69
Huxley, Prof., Sketch of. (Portrait) .....	739
Hypnotism in Animals .....	75
Ice, The Age of. (Illustrated) .....	641
Images and Shadows. (Illustrated) .....	665
Improved Deep-Sea Sounding Apparatus .....	255
Improvements in Street-Sprinkling .....	124
Inertia and Force .....	349
Inland Seas, their Physical Conditions .....	378
Insects, their Migrations .....	382
Instincts, Survival of .....	88
Intelligence of the Toad .....	126
Jupiter, News from .....	433
Land-Plants in Lower Silurian .....	762

	PAGE
Language, Emotional, of the Future.....	319
Leached Ashes as a Fertilizer.....	509
Lectures, Scientific.....	242
Liberal Education in the Nineteenth Century.....	1
Lignite-Beds of the Rocky Mountains.....	763
Lime-Soils and Potato-Rot.....	637
Livingstone's Death.....	627
Localization of the Faculty of Speech.....	125
Lockyer, J. N., Sketch of. (Portrait).....	109
Locusts, A Swarm of.....	636
Malformations.....	383
Man, The Descent of.....	251
Man, Antiquity of.....	759
Man in the Miocene, Relics of.....	254
Mantis, or Praying Insect. (Illustrated).....	710
Mars by the Latest Observations. (Illustrated).....	187
Matter, Force, and Inertia.....	494
Matter, its Physical Constitution.....	493
Metamorphic Rocks, Age of.....	509
Meteorological Notes.....	507
Migrations of Insects.....	382
Mill, Education and Science.....	368
Mind, Brain and.....	253
Mind, Growth and Decay of.....	328
Minerals, Spang Collection of.....	433
Modern Optics and Painting. (Illustrated).....	415, 572
Moab, Land of, its Geology.....	764
Molecules, Theory of.....	276
Moners, Haeckel's. (Illustrated).....	181
Mud-Minnow, its Breeding Habits.....	744
Natural Grafting.....	380
Natural Varieties.....	382
New Method with the Brain.....	183
New Guinea, its Population.....	632
News from Jupiter.....	433
Notes.....	-127, 256, 383, 511, 639, 767
Observatory, United States Naval.....	704
Ocean Steamships.....	766
Octopus, The, and its Prey.....	254
Optics, Modern, and Painting. (Illustrated).....	415, 572
Origin of Life, The, and Evolution.....	713
Origin of the Potato-Disease.....	123
Our Ancestors on the Goose-Question. (Illustrated).....	565
Ozone and Atmospheric Electricity.....	456
Painting and Modern Optics. (Illustrated).....	415, 572
Papillon, Fernand, his Death.....	627
Papyrus, An Ancient.....	251
Parchment, Substitute for.....	123

	PAGE
Passions, Physiology of the.....	552
Past and Future of a Constellation. (Illustrated).....	291
Pathology of the Passions.....	656
Phenomena of Heredity.....	55
<i>Phylloxera Vastatrix</i> .....	381
Physical Conditions of Inland Seas.....	378
Physical Constitution of Matter.....	493
Planet, the Ringed. (Illustrated).....	39
Plants, Animal-like Functions of.....	382
Population of New Guinea.....	632
Potato-Disease, Origin of.....	123
Potato-Rot, Lime-Soils and.....	637
Powder-Mill Explosion.....	231
Praying Insect, or Mantis. (Illustrated).....	710
Prediction, A Scientific, verified.....	253
Preparations for the Coming Transit of Venus.....	212
Primary Concepts of Modern Physical Science.....	92, 219, 349
Proctor's Lectures.....	116
Proctor, R. A., Sketch of. (Portrait).....	486
Psychology of the Sexes.....	30
Public Instruction and Sanitary Science.....	421
Quicker than Lightning. (Illustrated).....	309
Quinine.....	380
Race-Improvement, Heredity and.....	170
Radicalism, Conservatism, and the Transition of Institutions.....	129
Raspberry, Garden, its American Origin.....	510
Rats, an Episode on. (Illustrated).....	344
Rebuilding of Antioch.....	126
Refrigerating Machine.....	639
Relations of Body and Mind.....	111
Relics of Man in the Miocene.....	254
Replies to Criticisms.....	295, 402, 541
Requirements of Scientific Education.....	208
Ringed Planet, The. (Illustrated).....	39
Rumford's Discoveries in Thermodynamics.....	758
Salmon, Growth of. (Illustrated).....	27
Sand-Blast.....	511
Sanitary Science and Public Instruction.....	421
Science, its Influence on Philosophy.....	619
Science, Education, and Aristocracy.....	480
Science and the Press.....	635
Science, Physical, Primary Concepts of.....	92, 219, 349
Scientific Education, Requirements of.....	208
Scientific Lectures.....	242
Scientific Prediction verified.....	253
Scientific School, A New.....	241
Sensation and Motion in Plants.....	761
Sericulture in Brazil.....	250
Serpents. (Illustrated).....	257

	PAGE
Sewage Fertilization.....	507
Sewage, Utilization of.....	767
Sex, is it determined by Nutrition.....	761
Sexes, Psychology of the.....	30
Shadows, Images and. (Illustrated).....	665
Shark, The Shovel-nosed. (Illustrated).....	65
Signaling, Electric.....	581
Silk-worm's Thread, its Length.....	508
Solar Prominences, The Chromosphere and. (Illustrated).....	385
Sounding Apparatus, Improved.....	255
Spang Collection of Minerals.....	433
Speech, Localization of the Faculty of.....	125
Spencer and the Women.....	746
"Spencer-Crusher," Another.....	621
Street-Sprinkling, Improvements in.....	124
Study of Sociology..... 129, 242, 295, 402, 492,	541
Substitute for Parchment.....	123
Subterranean Fish.....	639
Sun's Envelope.....	127
Sun-driven Engine.....	765
Survival of Instincts.....	88
Tarantism.....	766
Tennyson and Botany.....	193
Tests for Glycerine.....	510
Theory of Molecules.....	276
Toad, Intelligence of.....	126
Transit of Venus, Preparations for the Coming.....	212
Trout from an Artesian Well.....	759
Typhoid Fever, Etiology of.....	764
Unequal Power of the Eyes.....	379
United States Naval Observatory.....	704
Varieties, Natural.....	382
Vegetable Growth, Rapidity of.....	510
Vivisection.....	672
Walking, Swimming, and Flying. (Illustrated).....	528
Wasps' Nests of Clay.....	637
Water-Filters.....	759
"Water turned to Blood." (Illustrated).....	202
Weeping-Willow, The.....	252
Well, An Ancient, in Illinois.....	252
What the Chemistry of the Rocks teaches.....	694
Work and Influence of THE MONTHLY.....	747
Winslow, Forbes.....	760
World, The, before the Introduction of Life. (Illustrated).....	513
Year, A, of Geographical Work.....	735
Yosemite Valley of Glacial Origin.....	122



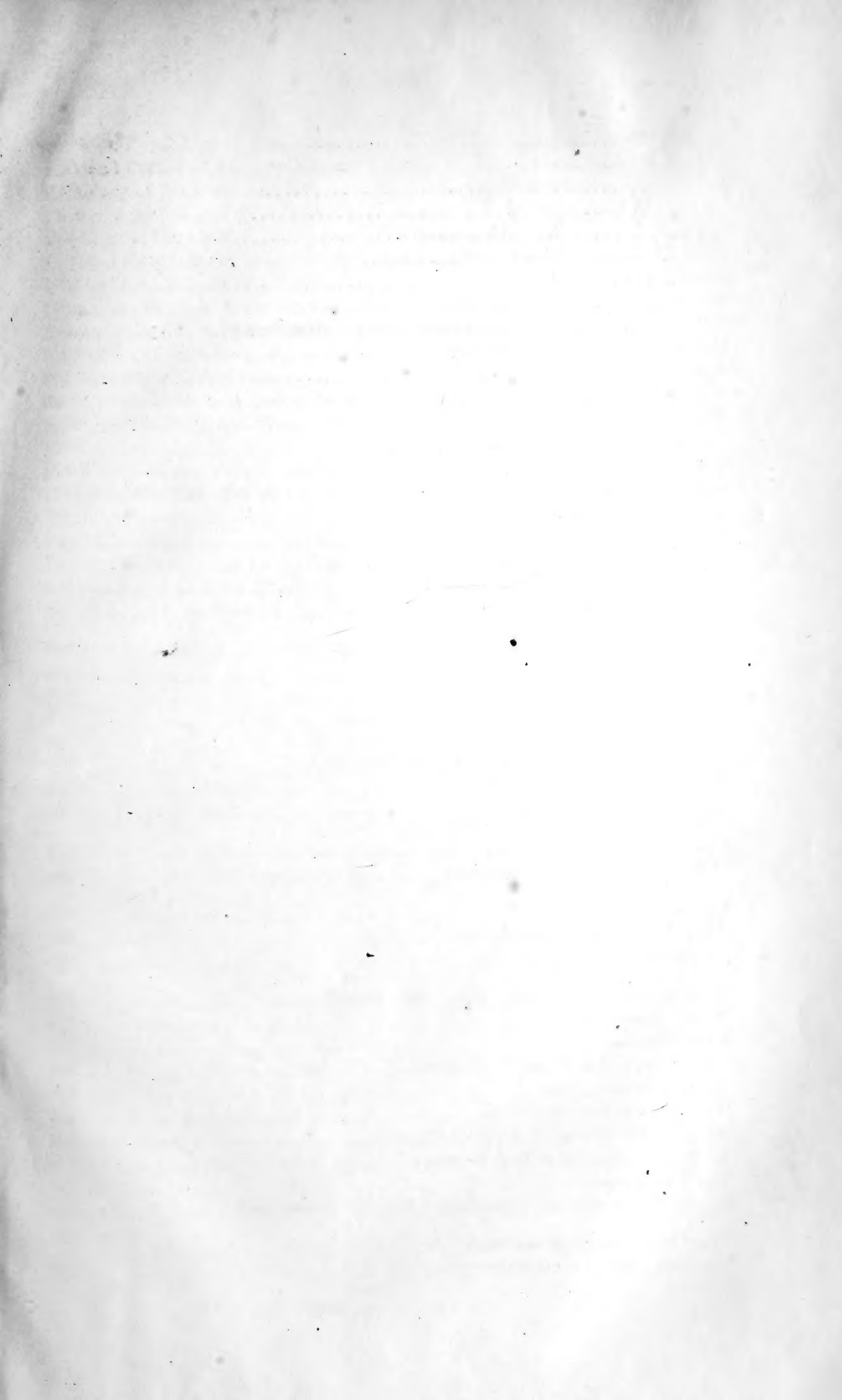





3 2044 106 273 808

