

DEC. 67

NUWC TP 25
COPY



nuwc

A PORTABLE, GENERAL-PURPOSE UNDERWATER SOUND MEASURING SYSTEM

By M. A. Calderon and G. M. Wenz

Listening Division

December, 1967

San Diego, California

QC
242.4
.C3
1967

DISTRIBUTION STATEMENT
THIS DOCUMENT HAS BEEN APPROVED FOR PUBLIC RELEASE AND SALE;
ITS DISTRIBUTION IS UNLIMITED.

NAVAL UNDERSEA WARFARE CENTER

An activity of the Naval Material Command

G. H. Lowe, Capt., USN
Commander

Wm. B. McLean, Ph.D.
Technical Director

The work described in this report was performed under SF 101 03 15, Task 8119 (NEL L20471) by members of the Listening Division. The report covers work from January 1965 to July 1966 and was approved for publication 22 December 1967.

The authors are indebted to R. Cruse for the design of the pressure measuring system; to H. Carmichael for much of its construction; to J. Leonard for the design and construction of the calibrate boxes; and to G. Beilke for his suggestions and assistance in field tests.

Under authority of
Curtis R. Haupt, Head
Sensor Development Dept.

purpose underwater n. G. M. Wenz e Center 25)	RETURNED
	(Det.) 22 May 69 from 3 Jan 69

PROBLEM

Specify and procure a portable, general-purpose, underwater-sound measuring system, primarily, but not exclusively, for the investigation of ambient noise in the ocean.

RESULTS

1. A portable underwater sound-pressure measuring system has been developed, and in a variety of situations has demonstrated the capability of measuring very low ambient-noise levels.

2. High self-noise levels at frequencies less than 50 to 63 Hz are quite likely to be present if measurements are made from a drifting ship and the cable is towed at the drift velocity. These high self-noise levels are believed to be due to a combination of flow noise and noise arising from cable vibrations.

3. These high self-noise levels can be satisfactorily eliminated by using a slack cable system as described in this report.

RECOMMENDATIONS

1. Use a slack cable system if a tethered system is used; and use an all-buoyant in preference to a nonbuoyant cable for a simple system to be used for measurements from a ship on the open ocean.



2. Perform calibration of the system with the random noise during the slack period; otherwise the high noise levels during towing may mask the random-noise calibrate signal at the lower frequencies.

3. Use a "pink" random noise (-3 dB/octave slope) for calibration, when noise with a negative spectrum slope is to be measured. With the same broadband level a pink random noise has a higher spectrum level at low frequencies than a flat random noise.

4. Use an untethered system, if it is available, to obtain ambient-noise measurements from a ship platform in the open ocean. This system should have the capability of obtaining data at any selected depth.

CONTENTS

INTRODUCTION...	<i>page 5</i>
SYSTEM DESCRIPTION...	6
Hydrophone and Preamplifier...	7
Cable...	11
Calibrate Boxes...	14
Sound-Level Meter and Analyzer...	17
Tape Recorders...	18
SELF-NOISE SOURCES...	19
FIELD TESTS...	20
Hydrophone Suspensions...	20
Cable Systems...	24
RESULTS OF FIELD TESTS...	30
Self-Noise...	30
Suspension and Cable Systems...	33
CONCLUSIONS...	33
RECOMMENDATIONS...	34
REFERENCES...	35
APPENDIX A: HYDROPHONE-DEPTH MEASURING SYSTEM...	37
APPENDIX B: HYDROPHONE-PREAMPLIFIER ASSEMBLY...	39
APPENDIX C: CABLE SPECIFICATIONS...	45

TABLES

1	Electrical Properties of the Cable...	<i>page 12</i>
2	Lower and Upper Cutoff Frequencies and Midpoint Frequencies for the Octave Bands of the Sound Level Meter...	17

ILLUSTRATIONS

- 1 Block diagram of the Basic Underwater Sound-Measuring System... *page 6*
- 2 Basic Sound-Measuring System shown with portable tape recorder... *7*
- 3 System noise of the hydrophone-preamplifier... *8*
- 4, 5 Receiving responses of hydrophone M-H90-A, Serial Nos. 1 and 6... *9*
- 6 Block diagram of M-H90-A hydrophone with cable and connections... *10*
- 7 Diagram of hookup of cable conductors to cable connectors... *11*
- 8 Cross talk between calibrate pair and signal pair... *13*
- 9 Block diagram of calibrate box... *14*
- 10 Equivalent sound-pressure spectrum level of random-noise calibrate signal... *16*
- 11 Frequency-response curves of the portable tape recorder... *19*
- 12 Diagram of two hydrophone suspension systems... *22*
- 13 Spar-buoy type suspension system... *23*
- 14 All-buoyant cable system with shock-cord suspension... *25*
- 15 All-nonbuoyant cable system with a simple float suspension... *25*
- 16 Combination buoyant and nonbuoyant cable system with shock-cord suspension... *27*
- 17 Simplified all-buoyant cable system... *28*
- 18 Nonbuoyant cable system using spar-buoy suspension... *29*
- 19 Comparison of noise-spectrum levels for a towed system and a slack system... *31*
- 20 Strip-chart records of the one-third octave band levels centered at 10, 50, and 1000 Hz, and of the broadband... *32*
- A1 Block diagram of pressure module and associated ship equipment... *38*
- A2 External view of pressure module... *38*

INTRODUCTION

In many cases when underwater sound measurements have been needed, it has been the practice to assemble available hydrophones, cables, amplifiers, recorders, voltmeters, etc., making such provisions for calibration as permitted by the available equipment. This practice was often time-consuming and sometimes resulted in a less than effective system.

The need for an underwater sound measuring system has long been recognized and several such systems have been designed and built, for example, the "Suitcase" system¹ and the Noise Measuring Set AN/PQM-1A.² Such systems have proved to be very useful tools, but for some applications the size, weight, and power requirements have been a problem, and the procedures for accomplishing comprehensive calibrations have been tedious and time-consuming.

Included in the objectives for the system described herein was the minimization of size, weight, and power requirements. Other special objectives were:

1. Frequency range from 10 Hz to 10 kHz.
2. Minimum self-noise and maximum sensitivity for the measurement of low background noise levels.
3. Flexibility: capability for use from a rowboat on the one hand, or from a relatively large ocean-going research ship on the other.
4. "Off-the-shelf" components: catalog items or items of standard manufacture.
5. Simplicity in both operation and calibration.

Since system self-noise of an underwater measuring system involves not only the equipment used but also the way in which it is used, the definition of the system must necessarily include a discussion of the techniques and procedures of its use.

¹Superscript numbers identify references listed at end of report.

SYSTEM DESCRIPTION

The basic underwater sound measuring system is shown in the block diagram of figure 1, and figure 2 is a photograph of the system. Each of the elements will be described in detail. Some auxiliary equipment to determine the depth of the hydrophone can be used and such a system is discussed in Appendix A.

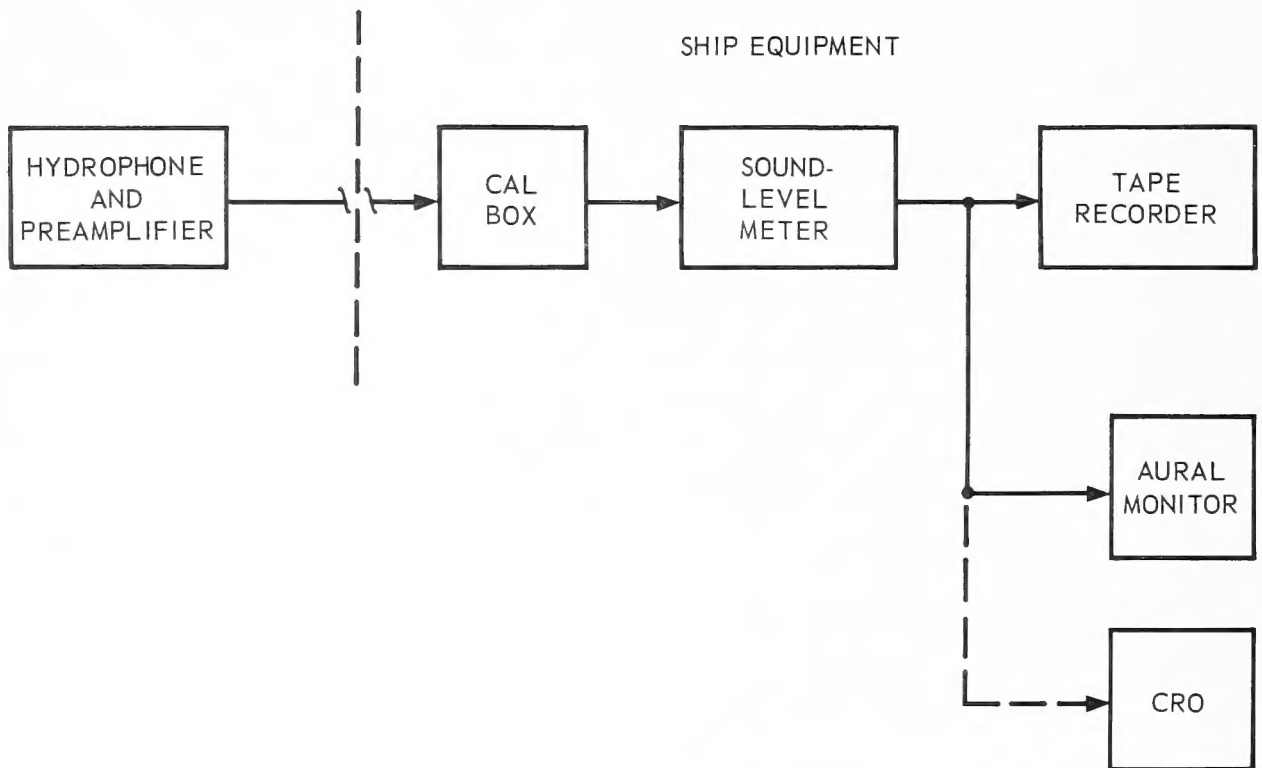

Figure 1. Block diagram of the Basic Underwater Sound-Measuring System.

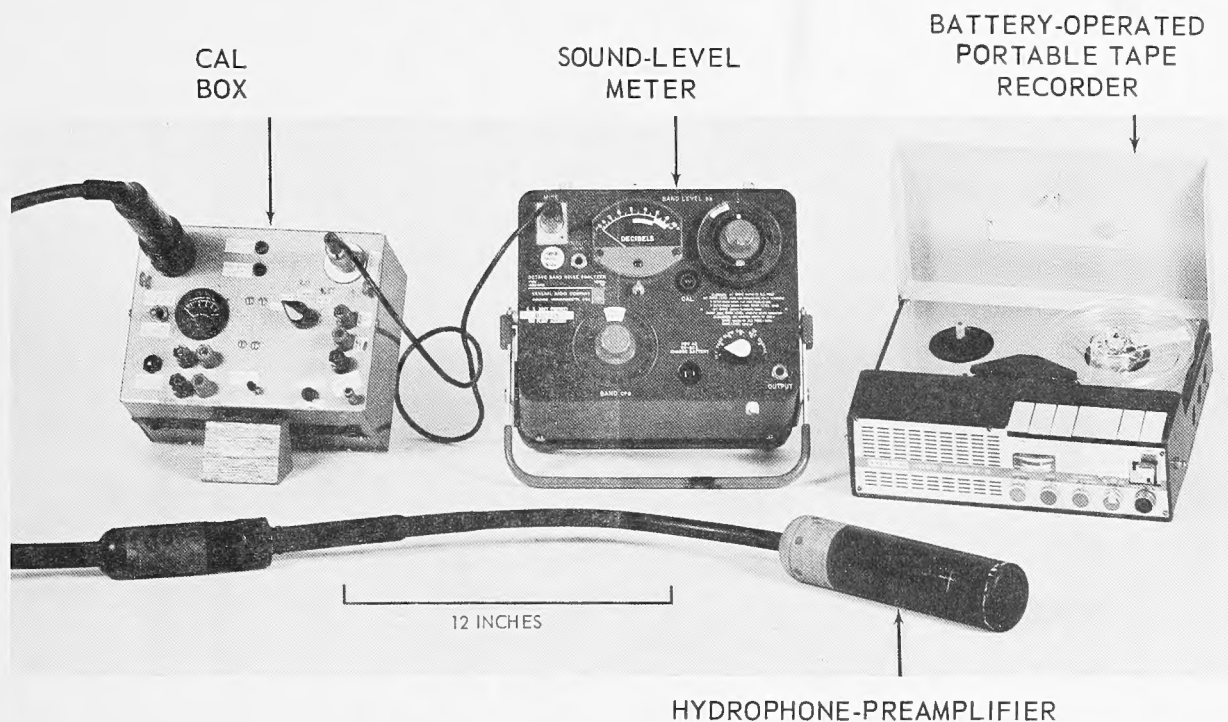

Figure 2. The Sound-Measuring System shown with a portable tape recorder.

Hydrophone and Preamplifier

The hydrophone-preamplifier assemblies (M-H90-A) were manufactured by Wilcoxon Research Co., Bethesda, Md., according to the specifications which are included in Appendix B. The crystal material used in PZT4 and the construction of the hydrophone is such that the acceleration sensitivity is reduced to a minimum. The acceleration sensitivity is given as less than $+60 \text{ dB}/\mu\text{bar/g}$. The source capacitance, sensitivity, and input impedance can be specified to obtain a hydrophone with a low input noise level and sufficient sensitivity to measure the lowest ambient noise levels in the frequency range of interest. The crystal was specified with a source capacitance of not less than 1000 pF with a sensitivity of not less than $-90 \text{ dBV re } 1 \text{ dyn-cm}^{-2}$. The input impedance of the preamplifier was specified to be

not less than 100 megohms with less than 30 pF of capacitance. The high input impedance is necessary to have good low-frequency response. This combination of source capacitance, sensitivity, and input impedance resulted in system input noise as shown by the curve of figure 3, at the preamplifier input referred to an equivalent SPL in water. The empirical ambient-noise minimum³ and the sea state 0 curve⁴ are given for comparison.

The actual receiving responses of two hydrophones as determined at an acoustic calibration facility (NUWC: SDL-TRANSDEC) are shown in figures 4 and 5.

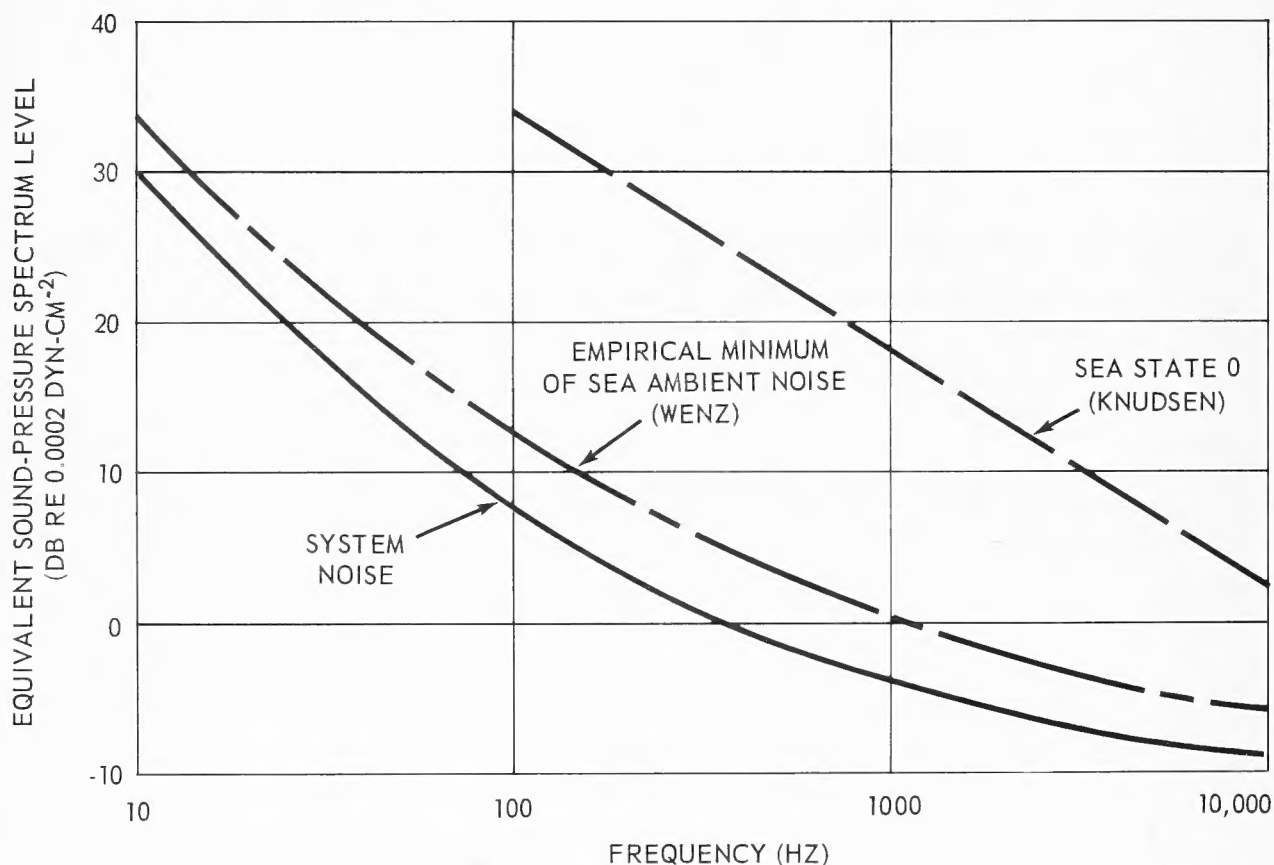

Figure 3. Comparison of system noise at hydrophone-preamplifier input to the sea state 0 curve (Knudsen) and to the empirical ambient noise minimum (Wenz).

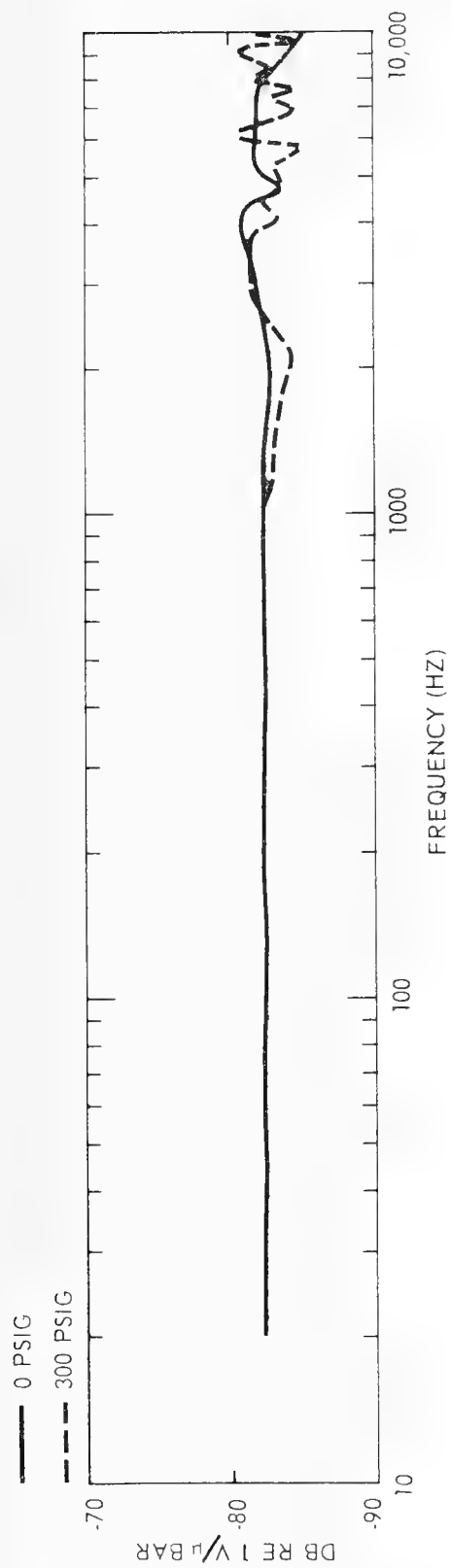

Figure 4. Receiving response of Wilcoxon Research Co. hydrophone M-H90-A, Serial No. 1.

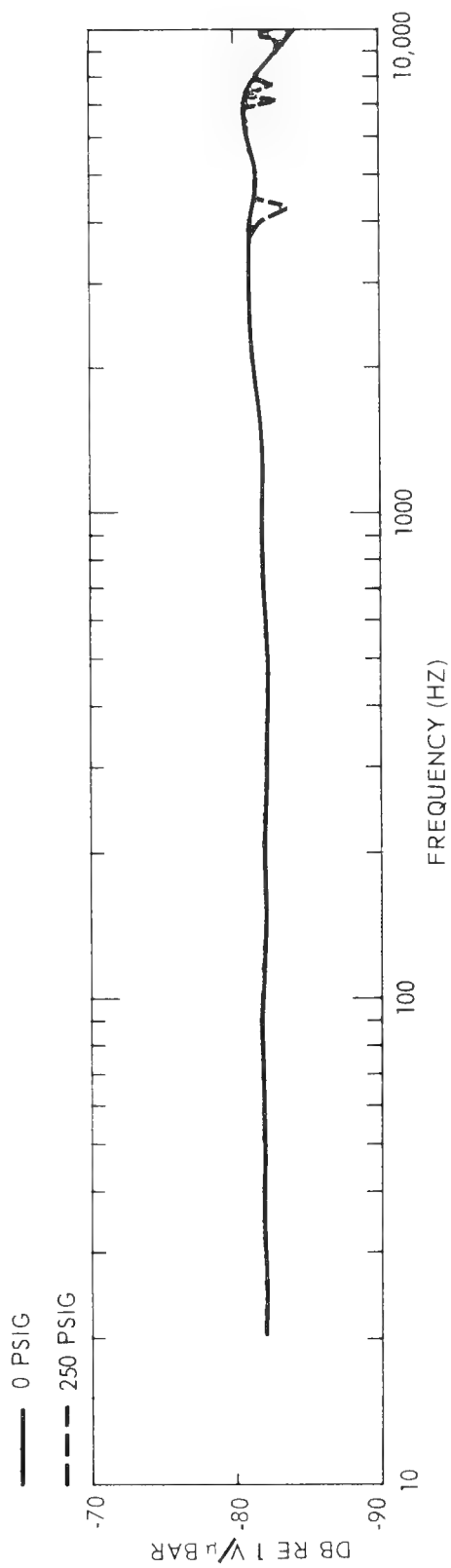

Figure 5. Receiving response of Wilcoxon Research Co. hydrophone M-H90-A, Serial No. 6.

The amount of voltage gain required for the hydrophone preamplifier is determined by the gain necessary to insure that the voltage levels corresponding to the lowest expected ambient noise levels would be above the input noise level of the remainder of the system. The desirability of maintaining as large a dynamic range as possible for the hydrophone-preamplifier requires that the minimum amount of gain necessary to accomplish the above purpose be specified. In this case the specified voltage gain is a nominal $30 \text{ dB} \pm 1 \text{ dB}$ (28 dB as measured).

The output stage of the preamplifier was especially designed to prevent high frequency oscillation when used with long cables. This required the addition of two output transistors to the basic preamplifier and necessitated at least 12 mA of current at about 12 volts . The output impedance is less than 50 ohms , with a maximum output voltage not less than 2 volts rms .

The hydrophone and preamplifier unit with connections to the Marsh and Marine connector is shown in the simplified schematic of figure 6.

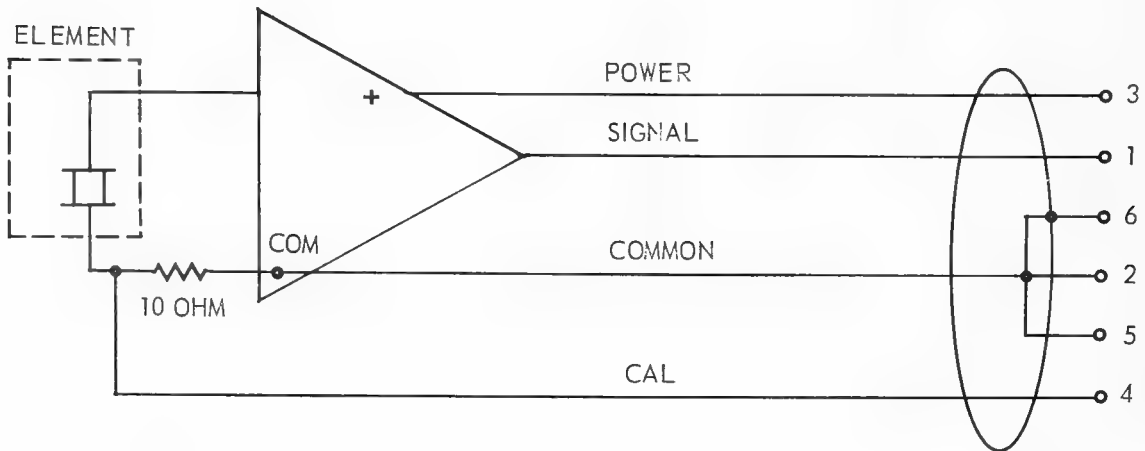

Figure 6. Block diagram of Wilcoxon Research Co. hydrophone M-H90-A with 18-inch cable and connections to a Marsh and Marine cable connector.

Cable

The underwater cable consists of three twisted pairs, one pair covered with a shield, and the group of three pairs covered with an overall shield. The two shields are tied to each other at only one end of the cable. The cables were procured in lengths of 50, 500, and 1000 feet. Two types of cable, nonbuoyant and buoyant, were available. Their electrical characteristics are identical. The nonbuoyant cable has a neoprene jacket with an OD of 0.440 inch. The cable connectors used are Marsh and Marine's XSL-6-CCR and XSL-6-CCP, one at either end, connected as shown in figure 7. A separate return lead was used for the calibration circuit to minimize common-mode voltages when long cables are used. The buoyant cable is similar but with a thinner neoprene jacket and an added flotation jacket of foamed polyethylene for a slight positive buoyancy in seawater.

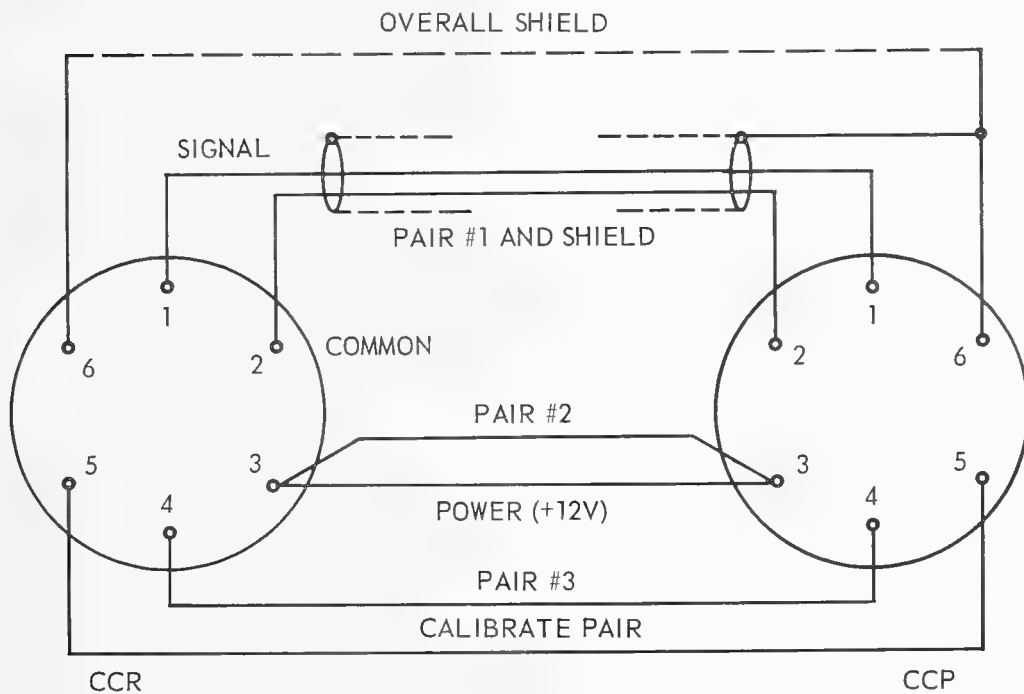

Figure 7. Diagram of hookup of cable conductors and shields to Marsh and Marine connectors XSL-6-CCR and XSL-6-CCP.

The two types of cable were obtained in different lengths to provide some degree of diversification in the kind of system that can be put together, depending on the desired use. Variations of cable systems actually used will be covered in the section, "Field Tests." The specification sheet for the cable is presented in Appendix C. The measured electrical properties are given in table 1. The cross-talk output of the signal pair when a signal is placed across the calibrate pair was measured and is shown in figure 8. About 1000 feet of cable were used for the cross-talk measurements.

TABLE 1. ELECTRICAL PROPERTIES OF THE CABLE*

Pin	Resistance (ohms/ft)
1	0.062
2	0.056
3	0.029
4	0.061
5	0.058

Pins	Capacitance (pF/ft)
1 & 2	25
2 & 3	26
3 & 4	28
4 & 5	25
1 & 6	38
2 & 6	43
3 & 6	68
5 & 6	38

*Values are the averaged measurements of three 1000-foot cables. Measurements were made with a GR type 1650A Impedance Bridge.

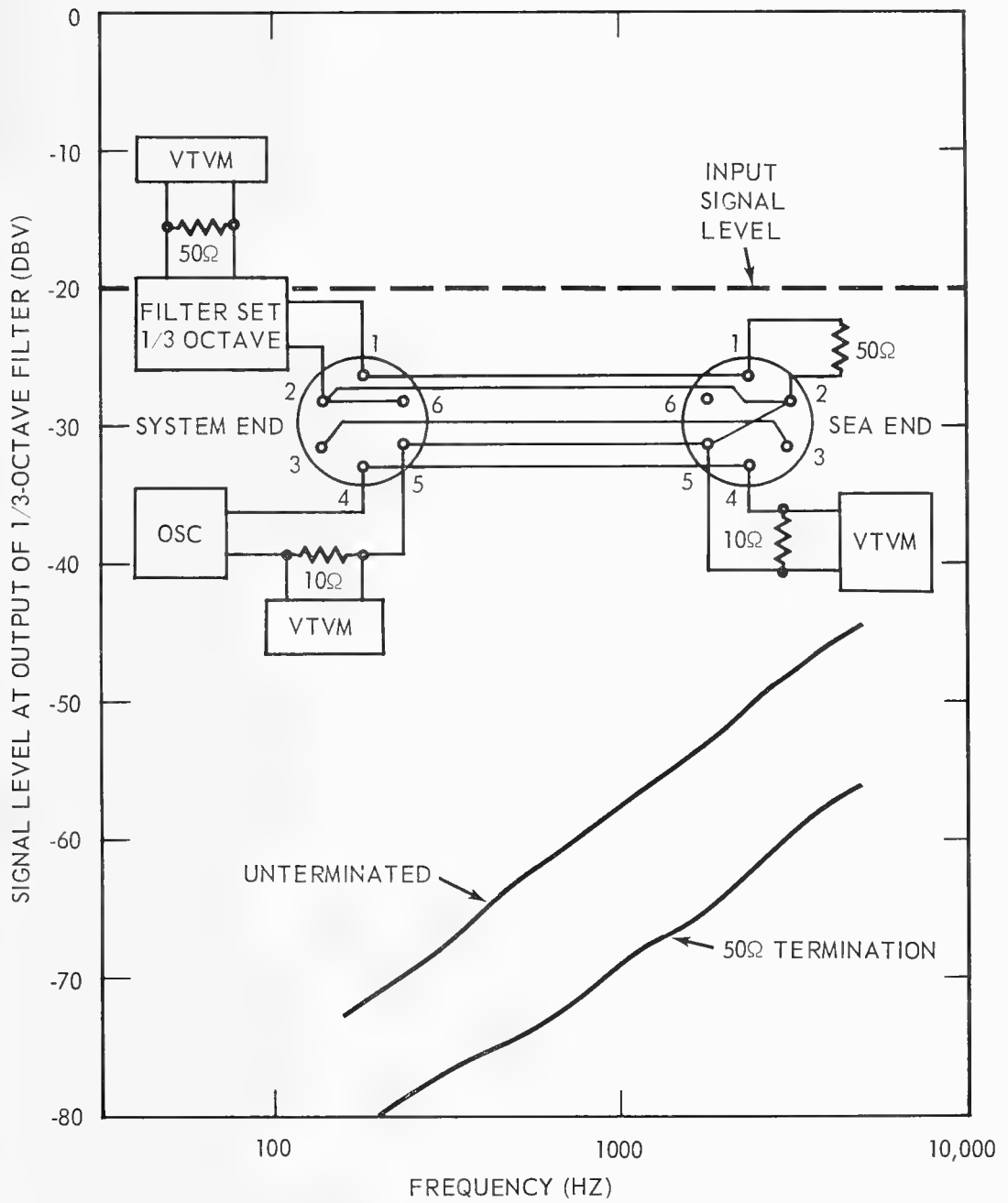

Figure 8. Cross talk between calibrate pairs and signal pair using arrangement shown.

Calibrate Boxes

The purpose of the calibrate boxes is to provide calibration signals to the hydrophone-preamplifier input using the insert resistor method. The calibrate boxes (fig. 9) contain a 1000-Hz sine-wave generator and a broad-band, flat-spectrum, random-noise generator. It also contains a monitoring circuit for measuring the current in the calibrate pair leads and a meter provides a visual indication of the amount of current. Provision for inserting external calibrate signals is included.

The calibration signals are applied through cable leads 4 and 5 to the 10-ohm resistor at the input of the hydrophone-preamplifier. The calibration signal thus appears in series with the hydrophone signal. This method

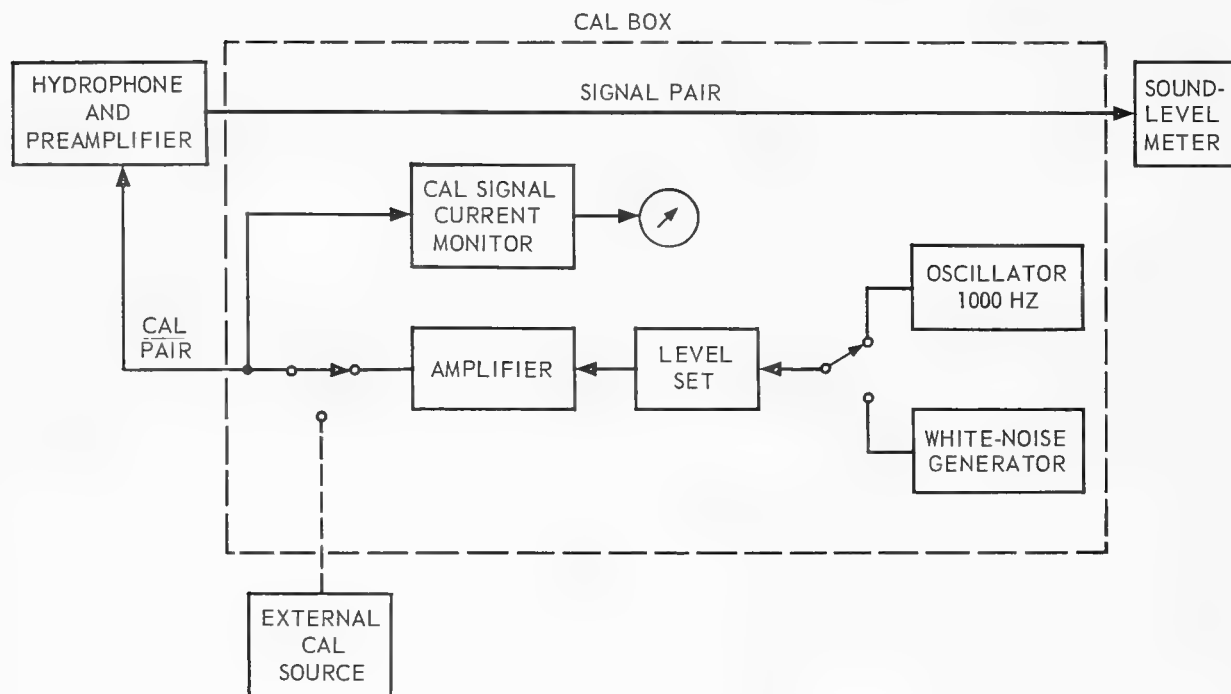

Figure 9. Simplified block diagram of the calibrate box and connections to the hydrophone and sound-level meter.

of calibration, using two easily inserted calibration signals, allows the entire electrical system to be calibrated very simply and as often as desired. The calibrate signals are recorded on tape along with the ambient-noise signal, and so also serve to calibrate any subsequent analysis equipment as well.

In practice the calibration signals are recorded just prior to the ambient-noise measurement. The level of the tone is adjusted precisely to the same known level each time by monitoring the current in the calibration circuit. Since the ambient-noise signal is present when the calibrate signals are applied, it is necessary to apply the calibrate signals at a much higher level than the ambient-noise voltage level.

To use this method of calibration it is only necessary to know the sensitivity of the hydrophone as a function of frequency, the insert level of the tone (as monitored) and the relative spectrum shape of the random noise as applied at the 10-ohm resistor. The sensitivity, $S(f)$, of the hydrophone is measured periodically at an acoustic calibration facility. The spectrum shape of the random noise is measured periodically using a one-third octave band analysis, and the relative spectrum level, $N'(f)$, is obtained by subtracting $10 \log_{10}$ (bandwidth) from the band level. The spectrum level of the random noise is determined by the difference, D , between the known tone level, T , and the one-third octave band level centered at the tone frequency.

$$N(1000) = T - D - 10 \log (\text{bandwidth})$$

where $N(1000)$ is the absolute spectrum level of the random noise at 1000 Hz. The absolute spectrum level at other frequencies is determined by

$$N(f) = N(1000) - [N'(1000) - N'(f)]$$

Conversion to an equivalent SPSL is made using the appropriate hydrophone sensitivity curve (fig. 4 or 5) as measured at an acoustic calibration facility.

$$\text{Equivalent SPSL} = N(f) - S(f) + 74$$

where the 74 is a conversion factor to a reference pressure of $0.0002 \text{ dyn-cm}^{-2}$. Figure 10 shows the equivalent SPSL of the tone and random noise of the two calibrate boxes as normally used. If the broadband level of the random noise should change, this will show up as a change in the difference,

D , and an adjustment in the equivalent SPSL $N(f)$ would be made. (It is assumed that while the random-noise level may change somewhat, the spectrum shape of the random noise signal does not.) Ambient-noise spectrum levels are then determined by a direct comparison with the random-noise calibrate signal at each frequency.

The use of this tone and random-noise calibration method eliminates the need for time-consuming calibration using many different frequencies to measure the frequency response of the system, although such calibrations can be made from time to time for comparison, using the external calibrate signal input.

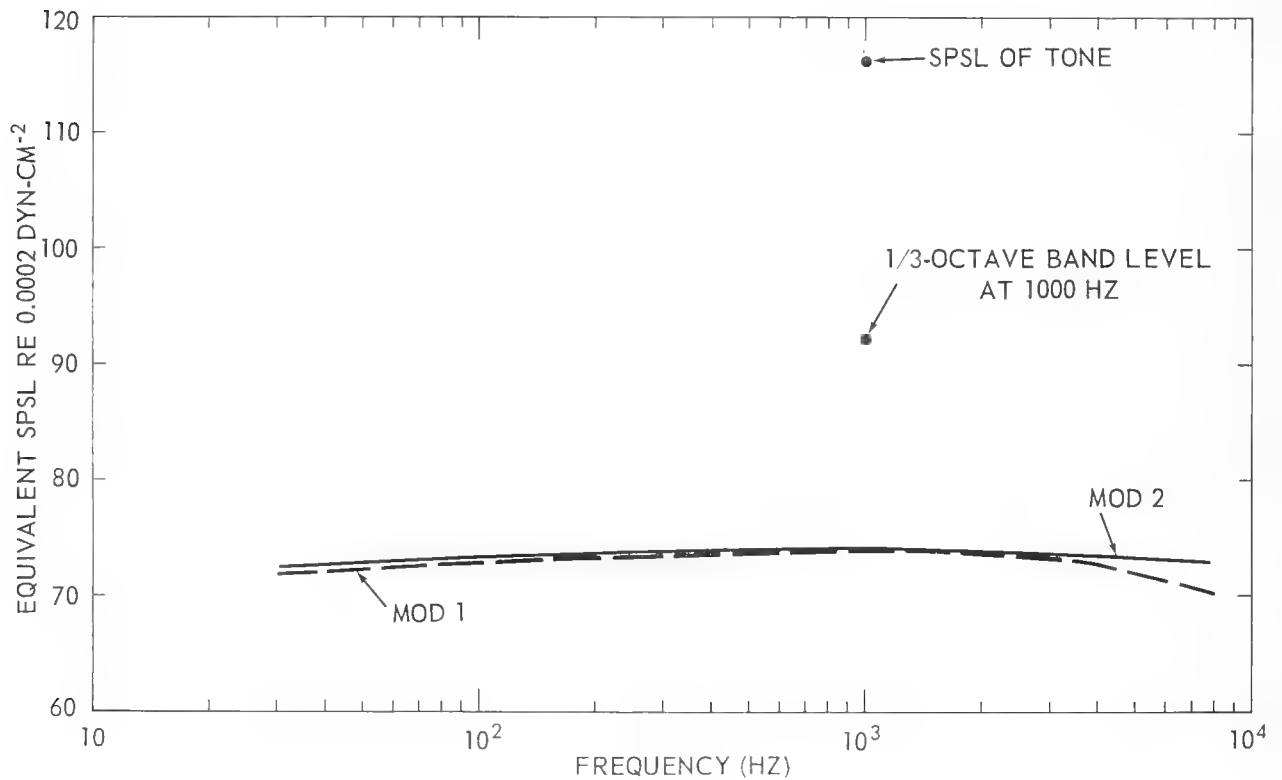

Figure 10. Equivalent sound-pressure spectrum level of random-noise calibrate signal.

Sound-Level Meter and Analyzer

The sound-level meter, General Radio Type 1558-AP Octave Band Noise Analyzer, is a portable, battery-operated audio-frequency spectrum analyzer. The analyzer contains a high-impedance microphone preamplifier, selectable one-octave bandwidth filters, an output amplifier, and an indicating meter. The gain of the analyzer can be set (depending on the sensitivity of the receiving transducer) so that the meter directly indicates the sound pressure level in any of its bands. The frequency response of the analyzer is flat ± 1 dB from about 20 Hz to 15,000 Hz in the ALL PASS position. The output of the analyzer is normally used in the ALL PASS position to provide an input signal to the tape recorder. Table 2 lists the lower and upper cutoff frequencies at the 3-dB down points and center frequency for all the octave bands of the analyzer.

TABLE 2. LOWER AND UPPER CUTOFF FREQUENCIES AND MIDBAND FREQUENCIES FOR THE ONE-OCTAVE BANDS OF SOUND LEVEL METER

LOWER CUTOFF FREQUENCY (Hz) 3-dB Down point	UPPER CUTOFF FREQUENCY (Hz) 3-dB Down point	CENTER FREQUENCY (Hz) (Geometric Mean)
22.3	44.6	31.5
44.6	89.2	63
89.2	177	125
177	354	250
354	707	500
707	1414	1000
1414	2828	2000
2828	5656	4000
5656	11,310	8000
11,310	22,620	16,000
ALL PASS		
A		

A portable battery-operated analyzer was chosen because it can be used in a variety of situations. It can be used in a semipermanent installation where data are taken at periodic intervals. It can also be used for a system requiring a completely portable system, such as would be needed in a small boat where no ac power is available, and will operate for about 30 hours on its battery. The battery can be recharged using the built-in charger. The octave band filters of the analyzer provide the means of doing an on-the-spot frequency analysis of the noise. The "A" weighting position is useful for pre-equalization when recording noise with predominant low frequency content.

Tape Recorders

The kind of tape recorder to be used depends on where and how the noise-measuring system is to be used. When the measurements are being taken from a relatively large ocean-going research ship a good quality ac-operated tape recorder can be used. For use on a small boat, where portability is essential and ac power is not available, a battery-operated tape recorder is necessary. The tape recorders described below are the ones used in this system and serve as examples of the two types.

The Ampex model 350-2P is a two-channel recorder which uses 10-1/2-inch reels of tape. Two tape speeds of 3-3/4 and 7-1/2 ips are available. The frequency response extends from about 15 Hz to 8000 Hz at the slower speed, and from about 10 Hz to 15,000 Hz at the higher speed.

The Uher 4000 Report-S is a portable battery-operated tape recorder which uses 5-inch reels of tape. Four speeds are available, 15/16, 1-7/8, 3-3/4, 7-1/2 ips. The measured frequency response for one of these tape recorders is shown in figure 11. These curves may be found to vary from the manufacturer's specifications depending on the condition and maintenance of the recorders.

The effective response can be extended below the low-frequency limit by using a high playback-to-record ratio for the analysis of the data.

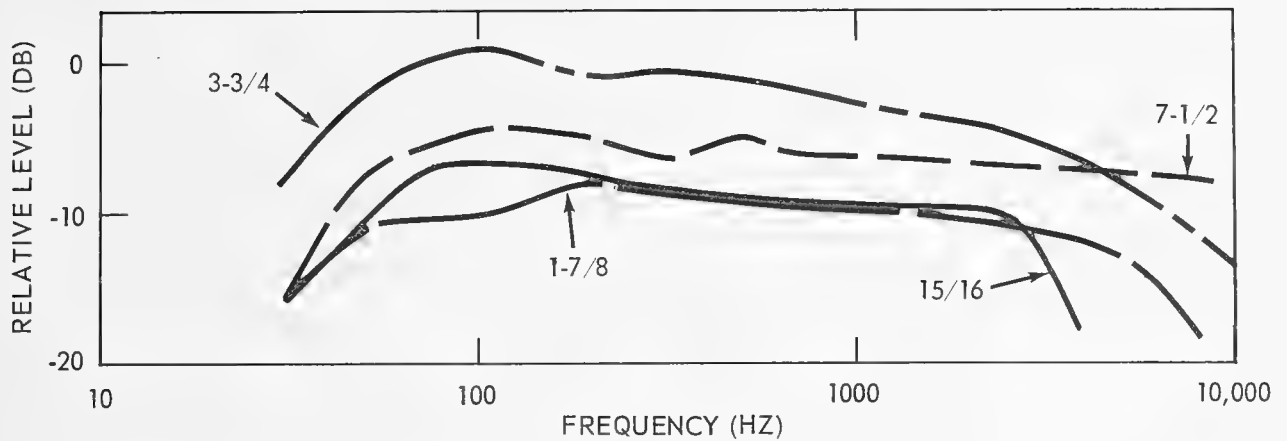

Figure 11. Frequency-response curves of the portable tape recorder.

SELF-NOISE SOURCES

The electronic system noise was discussed in the section on the hydrophone-preamplifier. This source of system noise was shown to be considerably below the noise levels to be expected from the lowest ambient-noise level likely to be encountered.

Another source of self-noise is due to the motions of the cable and suspension system. In particular, self-noise arises from flow noise, cable vibrations caused by towing the cable, and accelerations and static pressure changes which are caused by vertical motions of the hydrophone due to the action of surface waves on the system. In the cable systems which are described below the self-noise is reduced by isolating the hydrophone from the motion of the ocean and the motion of the ship. This is done through the use of shock cord in the suspension system and by maintaining slack in the cable during measurements. The acceleration sensitivity of the hydrophone, as mentioned previously, is minimized by design. The sensitivity of the system decreases below 10 Hz, so that it is relatively insensitive at the very low frequencies associated with major wave motion.

Another source of self-noise is radiated noise from machinery on board the platform. This noise must be reduced in order to obtain valid ambient-noise measurements. It is also desirable to place the hydrophone as far from the platform as possible when making these measurements.

FIELD TESTS

Various hydrophone suspension systems and cable systems were tested at sea to attempt to devise a system or systems which have low self-noise, are simple to use, and which are adaptable for measurements in deep or shallow water. Tests were run using various cable combinations of buoyant and nonbuoyant cable and suspension systems to attempt to determine the self-noise of the cable systems for a taut and for a slack cable, and also to determine which system of those tested was most suitable. Descriptions of the suspension systems and of the cable systems follow.

Hydrophone Suspensions

The purpose of a hydrophone suspension is to isolate the hydrophone from vertical motions which are induced by surface waves and swells. The isolation should be sufficient to prevent "blocking" of the system which is caused when excessively high noise voltages are applied to the preamplifier input.

As a starting point for the development of a suspension system, a system based on one developed by General Dynamics/Electric Boat was used³ (fig. 12A). It consists of a hydrophone-preamplifier unit, a 50-foot cable, a buoy (a flexible inflated plastic hose), a 50-foot shock cord

between the buoy and the 50-foot cable, and a 100-foot line, also between the buoy and the 50-foot cable. The shock cord is meant to isolate the hydrophone from the motion of the surface waves and the line is to prevent the shock cord from being extended beyond its elastic limit and possibly breaking and the float being lost. The inflated buoy was weighted so that most of the float was underwater, the purpose being to reduce the effect of waves on it. The weight in water of the 50-foot cable and hydrophone was adjusted to about 2 or 3 pounds, so as to provide the right amount of weight on the shock cord for proper operation.

Another suspension system which was tested is shown in figure 12B. It consists simply of floats attached to a line which is connected at the other end to the junction of a 50-foot cable and a 1000-foot length of nonbuoyant cable. No shock cord was used in this system for isolation.

A suspension used during part of an extended cruise of USNS Charles H. Davis (AGOR-5) consisted simply of an inflated plastic hose, which was tied with about a 10-foot line about 300 feet from the sea end of the buoyant cable when operating in deep water. No shock cord was used in this suspension. The float can be attached at any place on the cable, thus regulating the depth of the hydrophone. The plastic hose was weighted so that most of it would be underwater, but with enough buoyancy remaining so that it could support the system.

A spar buoy was used as a suspension for a system to be used on a small boat for taking data several miles from the mother ship. The spar buoy (see fig. 13) was a hollow plastic tube about 3 inches in diameter and about 20 feet long. One end was sealed airtight. In the operating position the lower end of the tube was left open and the tube was allowed to partially fill with water. The upper part of the tube contained some trapped air which provided the buoyancy.* The buoy was very stable and did not appear to be much affected by the wave action. It had enough buoyancy to support the hydrophone and cable which were attached to the bottom end.

* The open-end spar buoy was suggested by J.J. Blanchard.

A. SYSTEM INCORPORATING SHOCK CORD AND BUOYANT CABLE TO SHIP.

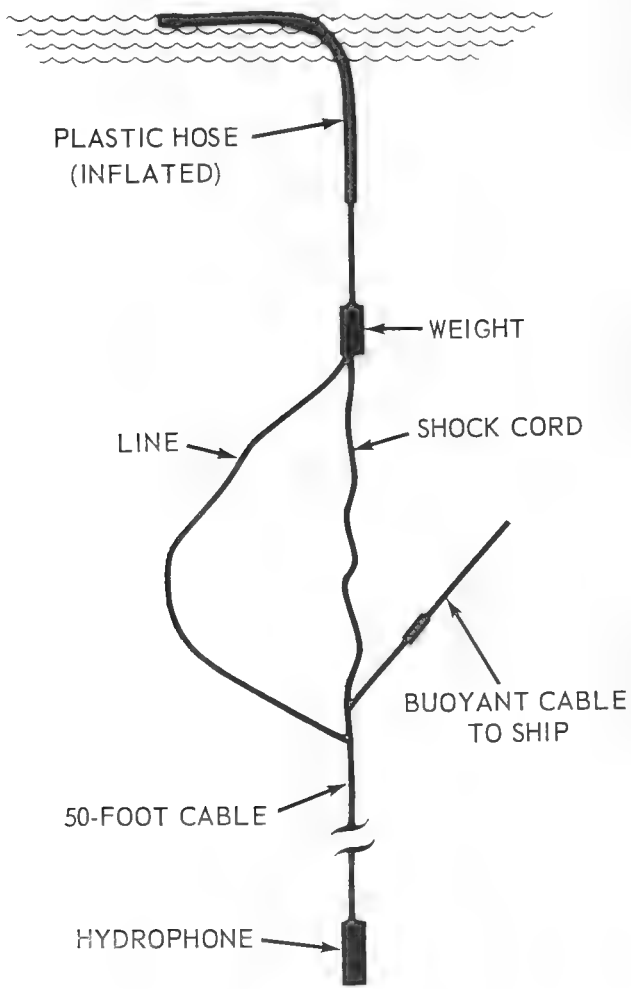

B. SYSTEM UTILIZING NONBUOYANT CABLE AND NO SHOCK CORD.

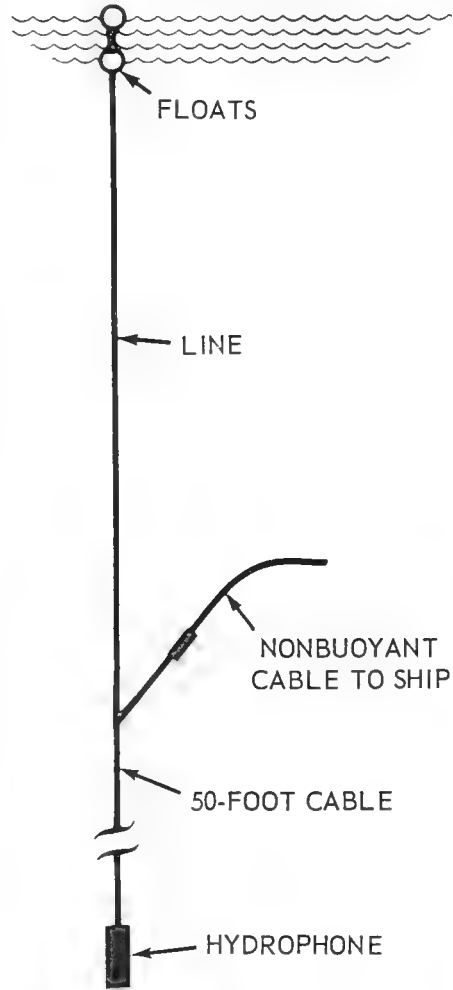

Figure 12. Diagram of two hydrophone suspension systems.

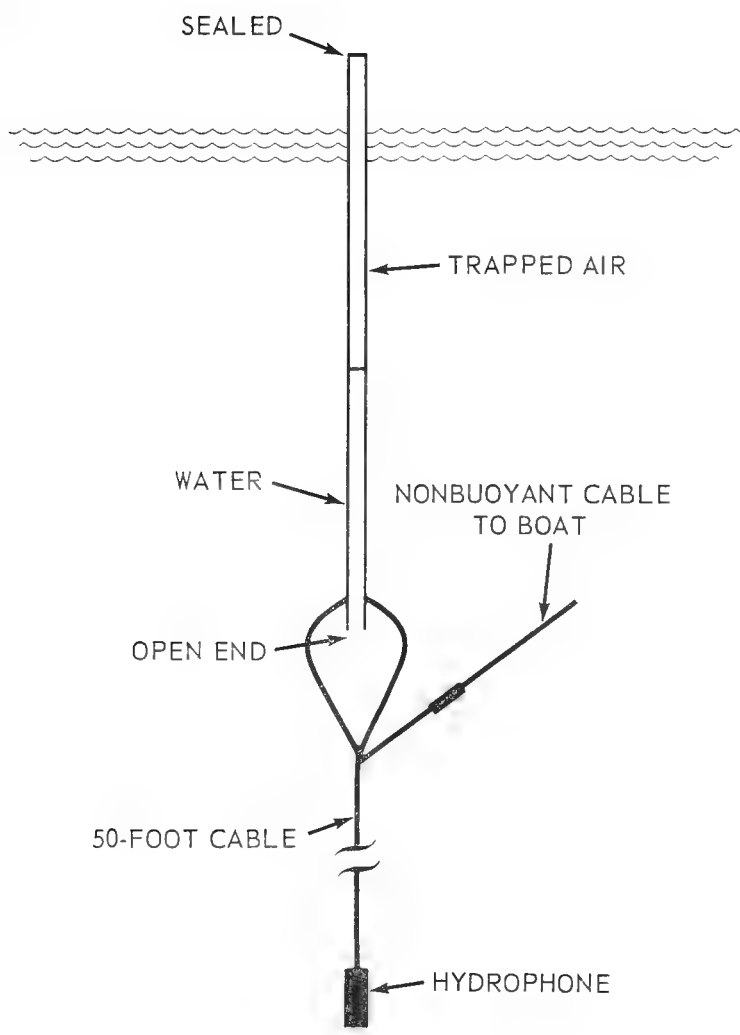

Figure 13. Spar-buoy type of suspension system as used from a small boat.

Cable Systems

Figure 14 illustrates a cable system using all-buoyant cable with the shock-cord suspension system. The procedure used in this system was to let the suspension and part of the buoyant cable drift out from the ship a predetermined distance, and hold the remainder of the cable on the deck coiled in a figure-8. The figure-8 was used so that there would be no twist in the cable as it was let out. At the start of a run the cable would be payed out fast enough to keep it slack but not so fast that it would tend to coil up as it floated on the surface. This system stabilized very quickly and there was little or no overloading of the signal from the hydrophone when the cable was slack. The recording time was limited to about 10 minutes with this system, since at a typical ship-drift rate of 1 knot a 1000-foot length of cable would drift out in about 12 minutes.

A system using all nonbuoyant cable with the float and line suspension is illustrated in figure 15. The float provides enough buoyancy that the hydrophone would not be pulled under by the weight of the nonbuoyant cable. In this method of operation the floats and hydrophone would be placed overboard with a nylon line attached to the floats. About 300 feet of nylon line would be payed out, and also all the cable, so that initially the system would be as shown in figure 15. When ready for the test more nylon line would be payed out and the system would slowly drift apart until all slack in the cable would be taken up and the hydrophone would start being towed. To repeat a run the nylon line would be pulled in to about 300 feet as before. This system took more time to stabilize than did the previous cable system. "Blocking" of the hydrophone-preamplifier occurred for some time after the release of the nylon line at the start of the run because of excessively high voltage levels probably caused by accelerations of the hydrophone; however the system settled down and thereafter was quiet. It was also noted that the combined weight of the cable and the drag made it necessary to use quite a large force to pull the cable back on board. It was feared that the cable might not stand up to repeated use in this way.

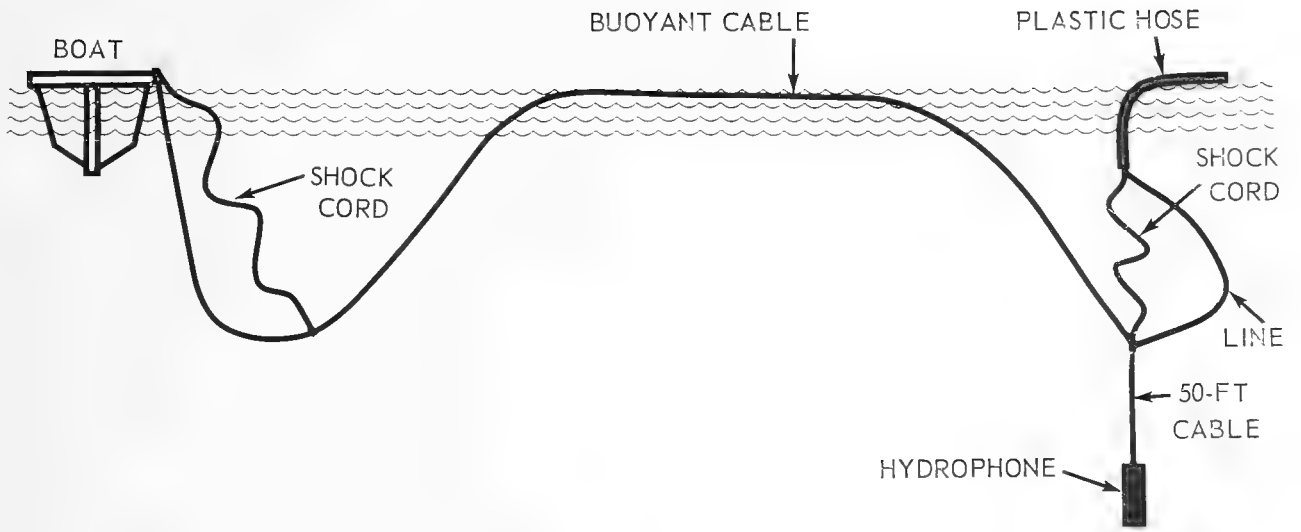

Figure 14. All-buoyant cable system using the shock-cord hydrophone suspension.

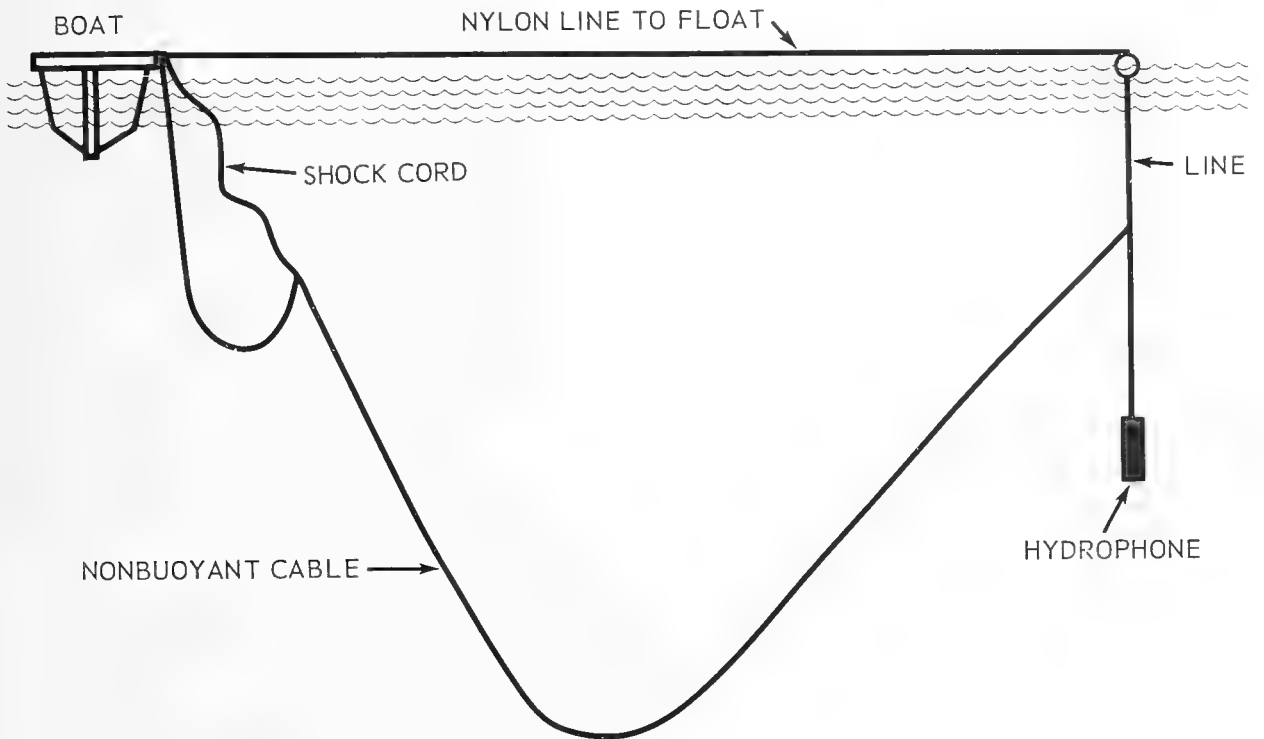

Figure 15. All-nonbuoyant cable system using a simple float suspension.

A third system used a combination of a buoyant and a nonbuoyant cable with the shock-cord suspension system (fig. 16). The buoyant cable was used to place the hydrophone farther away from the ship, to minimize the interference from the radiated noise of the ship. A nylon line was also used for this system and was attached to the float. The float had enough buoyancy to prevent the weight of the nonbuoyant cable from pulling the buoyant cable under the surface. The procedure used for this system is the same as that for the all-nonbuoyant cable system. The results obtained are similar to those of the previous system and, as before, the weights involved produced quite a large stress on the cable.

A cable system that was used on the Charles H. Davis (AGOR-5) (fig. 17) employed the simple float system described earlier. The system consisted of a total of 1500 feet of buoyant cable to which was attached a 50-foot length of nonbuoyant cable with the hydrophone. A 7-pound weight was attached to the nonbuoyant cable about 5 feet from the hydrophone, to sink the system to the desired depth. The depth was selected by attaching the inflated hose at the proper distance from the hydrophone. The 7-pound weight also presents a greater inertia to accelerating forces on the system. The procedure involved releasing 500 feet of cable over the side and letting it drift away while keeping the remainder on the deck in a figure-8. During the run the cable was payed out just fast enough to keep it slack throughout the run. After the run the cable was brought back in and placed in a figure-8 in preparation for the next run, leaving 500 feet of cable out.

Also used during the cruise of the Davis was a small-boat system consisting of nonbuoyant cable with the spar-buoy suspension system described earlier (fig. 18). About 500 feet was sufficient to provide a long enough slack period for an ambient-noise sample. A slack condition was obtained by paying out the nonbuoyant cable slowly while the spar buoy and the small boat drifted apart.

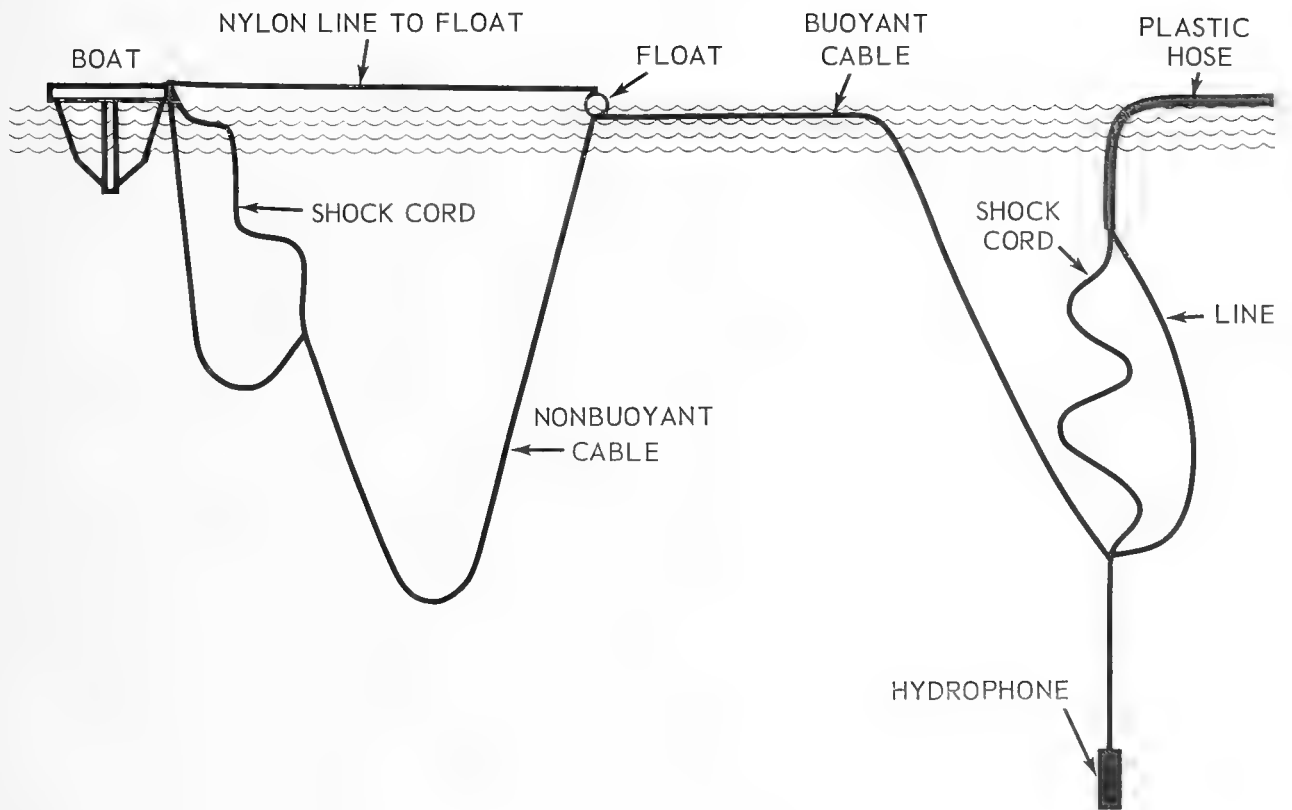

Figure 16. Combination buoyant and nonbuoyant cable system with the shock-cord suspension.

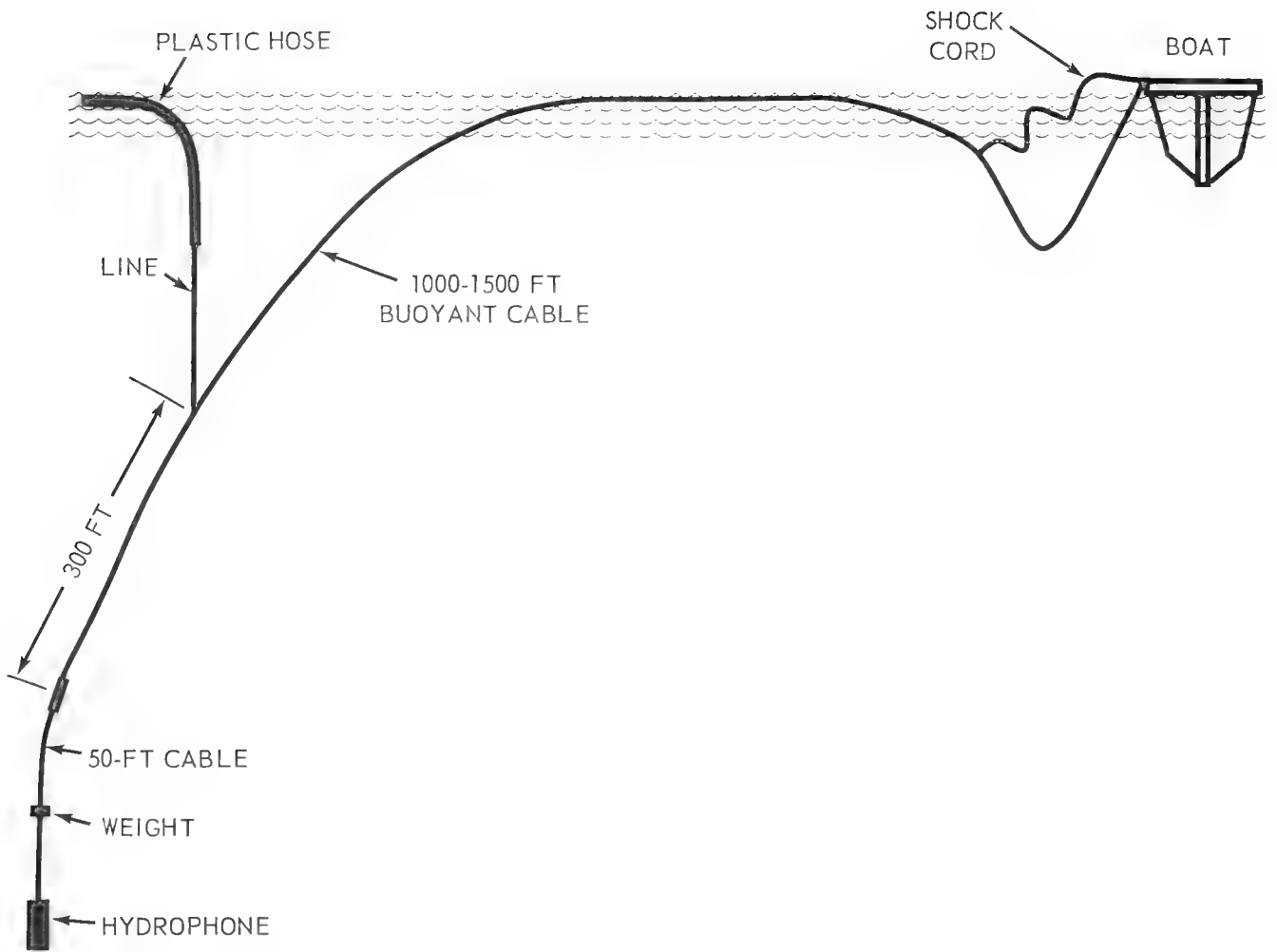

Figure 17. Simplified all-buoyant cable system.

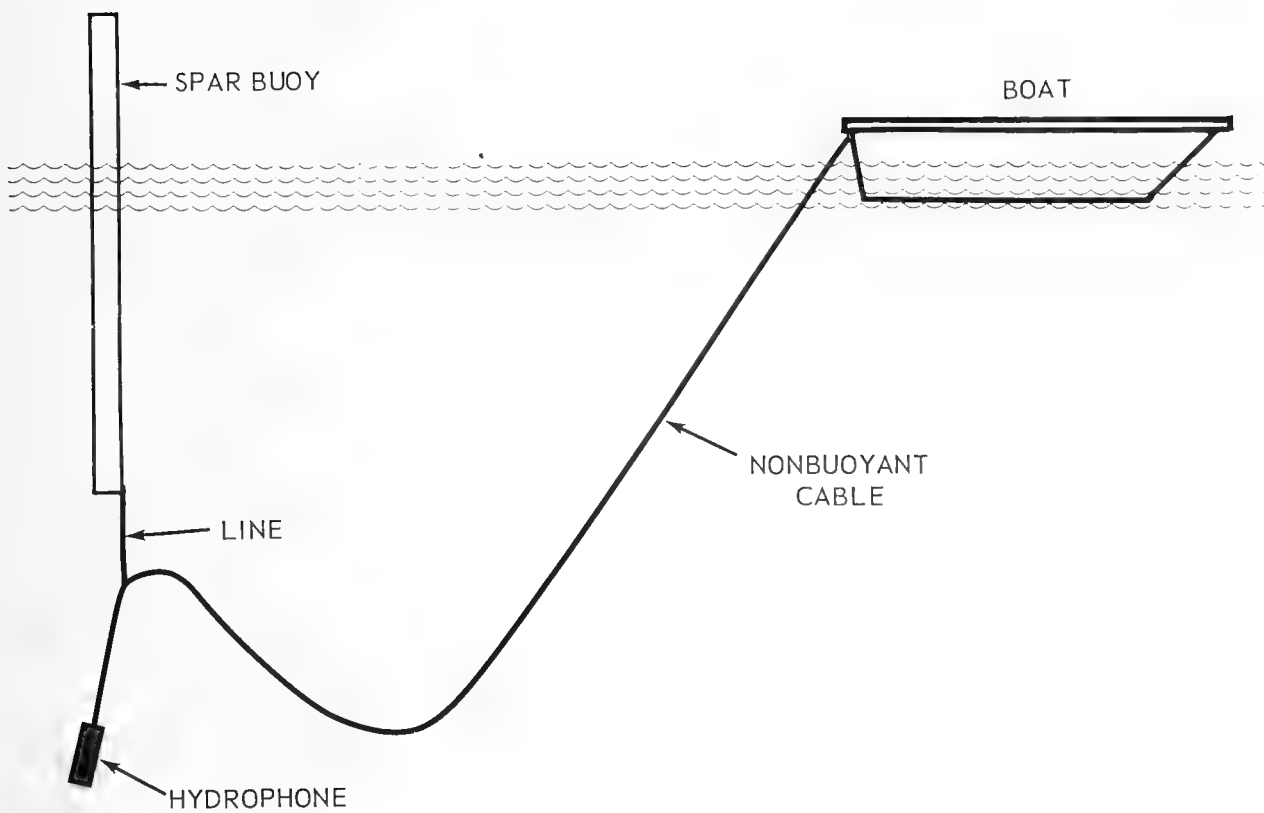

Figure 18. Nonbuoyant cable system using spar-buoy suspension for use from a small boat.

RESULTS OF FIELD TESTS

Self-Noise

The magnitude of the self-noise of the various suspension and cable systems is illustrated in figure 19. These results were obtained by a one-third octave band analysis of the recorded noise from the simplified cable system used on the Davis (fig. 17). The figure shows the sound-pressure spectrum level of the noise at frequencies from 10 to 1000 Hz at three different times during the same run. One sample was taken before the run had started and shows the measured level while the cable was taut and the hydrophone was being towed at a speed of about 1 knot. The next sample was taken a few minutes later with the cable in a slack condition. The difference in the two samples is about 30 dB at 10 Hz and decreases with increasing frequency until at about 40 to 50 Hz there is practically no difference in the measured level. The third sample was taken when the cable was again taut. This high low-frequency noise level during towing was also observed in all of the other cable systems tested and is believed to be due to flow noise and cable vibration.

Figure 20 shows four strip-chart records of the noise sample. Three of them are one-third octave band levels which are centered at 10, 50, and 1000 Hz. The fourth is a broadband record of the measured ambient noise. At 10 Hz the noise level is high at the start and begins to drop as soon as the cable becomes slack and then rises again as the cable becomes taut toward the end of the run. Note that the character of the noise in the 50-Hz and the 1000-Hz bands during the taut condition is different from that in the slack-cable condition; however the level remains about the same.

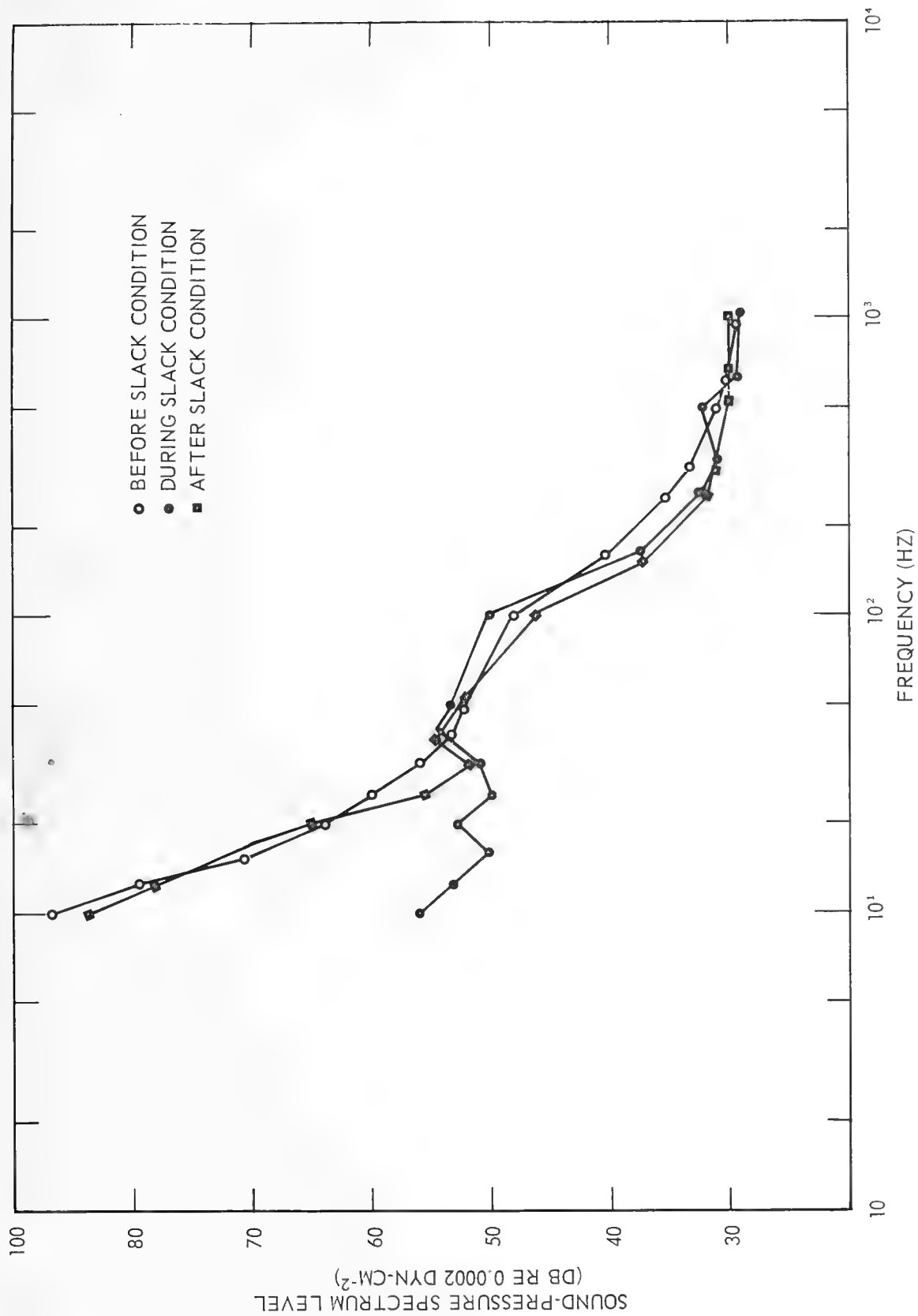

Figure 19. Comparison of the noise -spectrum levels for a towed system and a slack system.

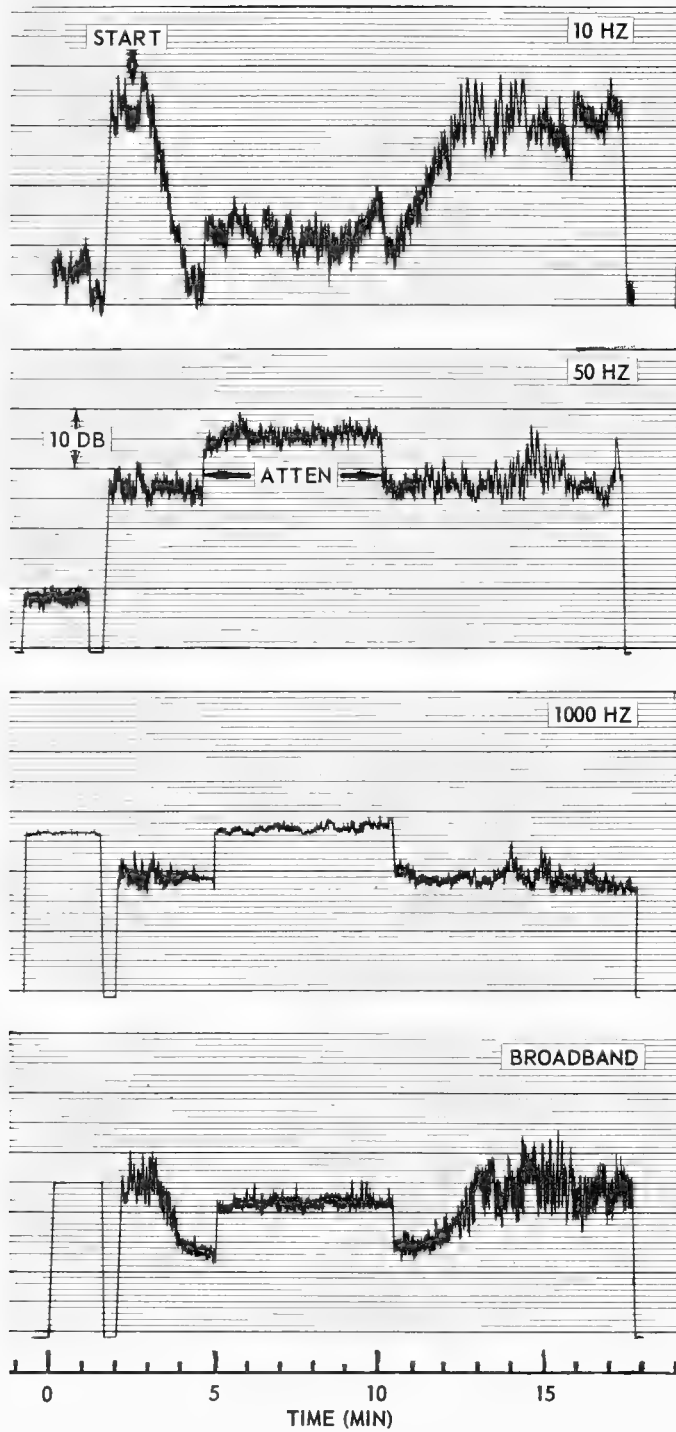

Figure 20. Strip-chart records of the one-third octave band levels centered at 10, 50, and 1000 Hz and of the broadband.

Suspension and Cable Systems

The all-nonbuoyant cable system and the system using both buoyant and nonbuoyant cable will be discussed together, since in many respects they are quite similar. These two systems overloaded more during the initial part of a run and took longer to stabilize than did the other systems. This effectively reduced the amount of slack time. Also, the two systems were not suitable for use in very shallow water, since the nonbuoyant cable would drag on the bottom. The stresses on the cable were also greater for the nonbuoyant systems.

The two remaining cable systems both use all-buoyant cable. One of them uses the shock-cord suspension and the other uses simply the inflated hose with no shock cord. Both of these systems are very quiet and both reach stability very quickly. The system without the shock cord has the advantages of not needing careful adjustment of the suspension system, and of permitting change in the hydrophone depth by simply changing the location of the suspension. In view of these features, the all-buoyant cable system without the shock-cord suspension was selected for general use.

CONCLUSIONS

A portable sound-pressure measuring system has been developed and used in a variety of situations, with the capability of measuring very low ambient-noise levels.

High self-noise levels at frequencies less than 50 to 63 Hz are quite likely to be present if measurements are made from a drifting ship and the cable is towed at the drift velocity. These high levels are believed to be due to a combination of flow noise and noise arising from cable vibrations which impart accelerations to the hydrophone.

These high self-noise levels can be satisfactorily eliminated by using the slack-cable system described in this report.

RECOMMENDATIONS

If a tethered system is used, the cable system should be slack, and for a simple system an all-buoyant cable system should be used in preference to the non-buoyant type for measurements from a ship on the open ocean.

Calibration of the system with the random noise should be done during the slack period; otherwise the high noise levels during towing may mask the random-noise calibrate signal at the lower frequencies.

Use a "pink" random noise (-3 dB/octave slope) for calibration, when noise with a negative spectrum slope is to be measured. With the same broadband level a pink random noise has a higher spectrum level at low frequencies than does a flat random noise.

If available, an untethered system should be used to obtain ambient-noise measurements from a platform in the open ocean. This system should have the capability of obtaining data at any selected depth.

REFERENCES

1. Woods Hole Oceanographic Institution Reference 52-10, An Experimental Portable Listening Device for Detection, Measurement and Recording of Underwater Sound, by W. Dow, March 1952
2. Bureau of Ships NavShips 92277, Instruction Book for Noise Measuring Set AN/PQM-1A, 21 July 1954
3. Wenz, G.M., "Acoustic Ambient Noise in the Ocean: Spectra and Sources," Acoustical Society of America Journal, v. 34, p. 1936-1956, December 1962
4. National Defense Research Committee. Division 6 Report No. 6.1-NDRC-1848, Survey of Underwater Sound: Report No. 3; Ambient Noise, by V. Knudsen and R. Alford, 26 September 1944
5. Chapman, F.E. and Rothenberg, E.B., "A Hydrophone Suspension System for Deep Water Noise Measurement," p. 199-209 in International Buoy Technology Symposium, Washington, 1964, Buoy Technology; an Aspect of Observational Data Acquisition in Oceanography and Meteorology; Transactions [Held] 24, 25 March 1964, Marine Technology Society, 1964

APPENDIX A: HYDROPHONE-DEPTH MEASURING SYSTEM

A block diagram of the pressure module with associated equipment is shown in figure A1. The pressure module is a waterproof stainless-steel cylinder designed to withstand pressures at least as great as any to which the hydrophone will be subjected (see fig. A2). The module contains a strain-gage pressure transducer, a differential amplifier, a VCO, and its own battery supply. The pressure transducer is calibrated by a resistor which is connected in parallel across one of the legs of the bridge. This lowers the resistance of the leg and corresponds to a known pressure change.

The cylinder was designed to be inserted between the 50-foot cable and the longer sea cable. With the pressure module in the system, the hydrophone-preamplifier obtained its power from the internal battery supply of the module. This was done so that the output of the VCO could be placed on the leads which are normally used to bring power to the hydrophone preamplifier.

The frequency of the VCO (12.5 to 14.5 kHz) was then measured with an HP model 521E frequency counter and recorded by a digital recorder model HP 561B. The digital clock is a model HP 571B.

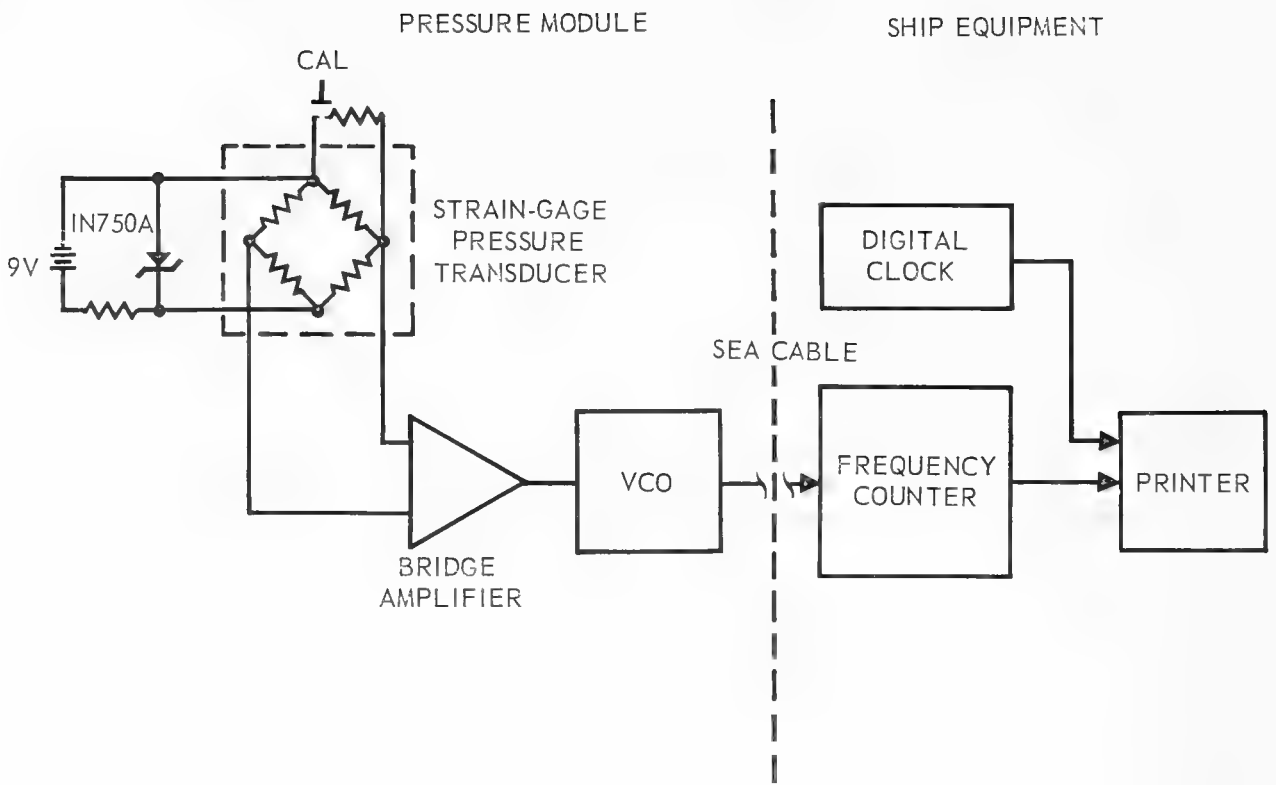

Figure A1. Block diagram of pressure module and associated ship equipment.

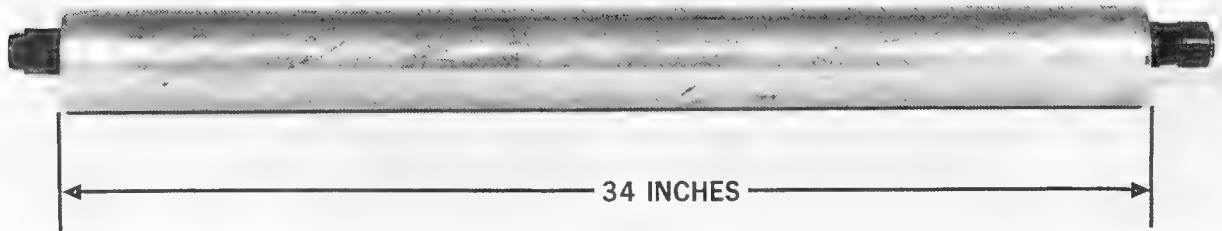

Figure A2. External view of the pressure module.

APPENDIX B: TECHNICAL SPECIFICATIONS, HYDROPHONE-PREAMPLIFIER ASSEMBLY

U.S. Navy Electronics Laboratory,
San Diego, California

19 October 1965

1.0 SCOPE

These technical requirements cover a hydrophone-preamplifier assembly to be used as part of an underwater sound-pressure-level measuring set which includes connecting cables up to 1000 feet in length. An important feature of this transducer is the capability of measuring very low sound-pressure levels. The assembly shall include a hydrophone, preamplifier with calibrate resistor, case, cable, and connector.

2.0 REQUIREMENTS

2.1 General. The construction shall be modern and of good commercial practice. The assembly shall have sufficient strength and ruggedness to withstand normal handling aboard ship at sea without suffering damage.

2.2 Hydrophone.

2.2.1 Voltage Response. Not less than -90 dBV for 1 dyn-cm⁻² sound pressure. Preference will be given to that design which minimizes the dependence of voltage response on static pressure and temperature. The variation of voltage response with pressure and temperature shall be stated by the supplier.

2.2.2 Capacitance. Not less than 0.001 microfarad.

2.2.3 Performance Goal. The characteristics are not specified exactly herein since the supplier should select that combination which, when used with his preamplifier,

will minimize the equivalent sound-pressure spectrum levels of the maximum system noise of the hydrophone-preamplifier combination (see section 2.6.3). The selected characteristics shall be stated by the supplier.

2.3 Preamplifier.

2.3.1 Input Resistance. Not less than 100 megohms.

2.3.2 Input Capacitance. Not more than 30 picofarads.

2.3.3 Voltage Gain. 30 dB \pm 1 dB.

2.3.4 Output Impedance. Not more than 50 ohms.

2.3.5 Open-circuit Output Voltage, Maximum. Not less than 2 V rms, 5 V peak-to-peak.

2.3.6 Power Supply. Not more than 5 mA. @ 10 - 14 Vdc. [Changed to 12 mA to accommodate added output stage.]

2.3.7 Calibrate Resistor. 10 ohms \pm 0.1 ohm.

2.4 Case.

The case for housing the hydrophone and preamplifier shall be cylindrical in shape with rounded ends approximating a hemisphere (see also section 3.0). The design shall allow convenient access to the preamplifier and calibrate resistor using only simple tools such as a screwdriver and small wrench. Remolding or revulcanizing is unacceptable.

2.5 Cable and Connector.

The assembly shall be supplied with 18 inches of water-proof low-noise cable and connector attached.

2.5.1 Cable. Five conductors (six conductors acceptable), cable strength sufficiently adequate to support the hydrophone assembly.

2.5.2 Connector. Six-pin, female, Marsh and Marine type XSL-6-CCP or equivalent for mating with Marsh and Marine XSL-6-CCR and XSL-6-BCR.

2.5.3 Connections. The cable and connector shall be wired as shown in figure 1.

2.6 Hydrophone-Preamplifier Assembly.

2.6.1 Frequency Response. 9.0 Hz to 11,200 Hz ± 1 dB.

2.6.2 Directionality. Omnidirectional, ± 1 dB about Z-axis, ± 1 dB about X- and Y-axis to 5 kHz, ± 3 dB about X and Y axis 5 to 11.2 kHz. The Z-axis is the axis of the cylindrical case (see also section 30).

2.6.3 System Noise. The equivalent sound-pressure levels of the maximum system noise of the hydrophone-preamplifier combination at 25°C shall not exceed the levels shown in figure 3 [in the main text]. Preference will be given to that design which minimizes system noise. Information as to the spectrum levels of the limiting noise shall be furnished by the supplier.

2.6.4 Shielding. The hydrophone and preamplifier shall be electrostatically shielded with the shield insulated from the water.

2.6.5 Acceleration Sensitivity. Preference will be given to that design which minimizes acceleration sensitivity. The acceleration sensitivity of the unit shall be stated by the supplier.

2.6.6 Size. Not more than 2.5-inch diameter by not more than 8-inch length, exclusive of the cable and connector. The minimum size consistent with good performance and economy of construction is desired.

2.6.7 Weight. Not more than 5 pounds. The minimum weight consistent with good performance and economy of construction is desired.

2.7 Environmental Requirements.

2.7.1 Operational Pressure. The assembly shall operate as specified at any static pressure up to 250 psi.

2.7.2 Operational Temperature. The assembly shall operate as specified at temperatures between 0° and 30° centigrade.

2.7.3 Stowage Temperatures. No permanent change in performance shall result from long periods of exposure to temperatures between -30° and 50° centigrade.

2.7.4 Handling. The assembly shall withstand normal handling aboard ship at sea without suffering damage.

2.7.5 Corrosion. Materials shall be chosen to resist corrosion in a saltwater environment.

3.0 NOTE

An overall spherical shape will also be acceptable if not more than 4 inches in diameter and provided all other requirements are met. The Z-axis for the spherical case is that diameter of the sphere which includes the point at which the cable is attached.

4.0 INFORMATION MATERIAL

The supplier shall furnish informational material in the form of sheets and graphs including, but not necessarily limited to, the following:

a. Schematic wiring diagram of complete assembly, including that of the preamplifier, showing all components and clearly identifying each component.

b. Complete parts list including sufficient information for procurement of each item, and keyed to the schematic diagram.

c. Graphs and/or tabulations showing spectrum levels of the voltage response, equivalent system noise, acceleration sensitivity.

d. Characteristics of the hydrophone and of the preamplifier.

5.0 QUALITY ASSURANCE PROVISIONS

The manufacturer shall be responsible for initial inspection and testing for compliance with the requirements. Final inspection and testing will be made by the Navy Electronics Laboratory after delivery.

APPENDIX C: CABLE SPECIFICATIONS

- CONDUCTOR: #24 AWG: 19/0.005" soft tinned copper wires, concentric stranded. (1/ 46#/M') OD 0.0025 in.
- Insulation: Copolymer (ethylene-propylene) color coded, nominal wall thickness 0.010 in. (0.45#/M') OD 0.045 in.
- Color Code: Solid color insulation. Four different colors.
- ASSEMBLY "A": Twist: Two CP24U conductors together with a right lay. (3.9#/ M') OD 0.090 in.
- Color Code: Each pair to have one common and one different color.
- ASSEMBLY "B": One CP24CP, assembly "A."
- Shield: Braid #36 AWG soft tinned copper wires, 6 ends, 16 carriers, 13.2 ppi, 30° angle, 90% nominal coverage. Bind with adhesive mylar tape, 1-layer, 50% lap. Nominal OD 0.120 in.
- CABLE ASSEMBLY: Core: Plastic monofilament. Nominal OD 0.020 in.
- 1st Layer: Cable, two CP24GP (assembly "A") and one SP24TPS (assembly "B") around the core with a left lay. Fill voids with rubber compound filler. Bind with adhesive mylar tape, 1-layer, 50% lap. Nominal OD 0.210 in.

SHIELD: Braid: #30 AWG soft tinned copper wires, 4 ends, 16 carriers, 8 ppi, 32° angle, 82% nominal coverage. Bind with #113 tape, 1-layer, butt lap. Nominal OD 0.280 in. (22#/M').

JACKET: Nonflotation Cable: Neoprene #480B, black, nominal wall thickness 0.080 in. Nominal OD 0.440 in. (51#/M').

Flotation Cable: Neoprene #480B, black, nominal wall thickness 0.040 in. Nominal OD 0.360 in. (23#/M').

FLOTATION JACKET: Cellular polyethylene, brown, nominal wall thickness 0.120 in. OD approximately 0.600 in. (37#/M').

PROPERTIES: Cable Weight ±10% per 1000 ft:

<u>Nonflotation Cable</u>	<u>Flotation Cable</u>
In air: 112#	In air: 140#
In water: 50#	In water: 12#

UNCLASSIFIED

Security Classification

DOCUMENT CONTROL DATA - R & D		
<i>(Security classification of title, body of abstract and indexing annotation must be entered when the overall report is classified)</i>		
1. ORIGINATING ACTIVITY <i>(Corporate author)</i> Naval Undersea Warfare Center San Diego, California 92152		2a. REPORT SECURITY CLASSIFICATION UNCLASSIFIED
		2b. GROUP
3. REPORT TITLE A PORTABLE, GENERAL-PURPOSE UNDERWATER SOUND MEASURING SYSTEM		
4. DESCRIPTIVE NOTES <i>(Type of report and inclusive dates)</i> Research and Development Report, January 1965 - July 1966		
5. AUTHOR(S) <i>(First name, middle initial, last name)</i> M.A. Calderon and G.M. Wenz		
6. REPORT DATE	7a. TOTAL NO. OF PAGES 46	7b. NO. OF REFS 5
8a. CONTRACT OR GRANT NO.	9a. ORIGINATOR'S REPORT NUMBER(S) TP 25	
b. PROJECT NO. SF 101 03 15 Task 8119 c. (NEL L20471) d.	9b. OTHER REPORT NO(S) <i>(Any other numbers that may be assigned this report)</i>	
10. DISTRIBUTION STATEMENT This document has been approved for public release and sale; its distribution is unlimited.		
11. SUPPLEMENTARY NOTES	12. SPONSORING MILITARY ACTIVITY Naval Ship Systems Command Department of the Navy	
13. ABSTRACT A portable underwater sound-pressure measuring system was developed and tested. The system was shown to be capable of measuring very low ambient-noise levels. High self-noise levels at frequencies less than 50 to 63 Hz are likely to be present if measurements are made from a drifting ship, and the cable is towed at drift velocity, probably because of a combination of flow noise and noise arising from cable vibrations. These high self-noise levels can be satisfactorily eliminated by using a slack cable system as described in the report.		

UNCLASSIFIED

Security Classification

14 KEY WORDS	LINK A		LINK B		LINK C	
	ROLE	WT	ROLE	WT	ROLE	WT
Underwater Ambient Noise - Measurement Underwater Sound - Measurement						

UNCLASSIFIED

Security Classification

Naval Undersea Warfare Center, San Diego, Calif.
TP 25

A PORTABLE, GENERAL-PURPOSE UNDERWATER SOUND MEASURING SYSTEM, by M. A. Calderon and G. M. Wenz, 46 p., 22 Dec 67.

UNCLASSIFIED

A portable underwater sound-pressure measuring system was developed and tested. The system was shown to be capable of measuring very low ambient-noise levels. High self-noise levels at frequencies less than 50 to 63 Hz are likely to be present if measurements are made from a drifting ship and the cable is towed at drift velocity, probably because of a combination of flow noise and noise arising from cable vibrations. These high self-noise levels can be satisfactorily eliminated by using a slack cable system as described in the report.

1. Underwater Ambient Noise - Measurement
2. Underwater Sound - Measurement

I. Calderon, M. A.
II. Wenz, G. M.

SF 101 03 15, Task 8119
(NEL L20471)

This card is UNCLASSIFIED

Naval Undersea Warfare Center, San Diego, Calif.
TP 25

A PORTABLE, GENERAL-PURPOSE UNDERWATER SOUND MEASURING SYSTEM, by M. A. Calderon and G. M. Wenz, 46 p., 22 Dec 67.

UNCLASSIFIED

A portable underwater sound-pressure measuring system was developed and tested. The system was shown to be capable of measuring very low ambient-noise levels. High self-noise levels at frequencies less than 50 to 63 Hz are likely to be present if measurements are made from a drifting ship and the cable is towed at drift velocity, probably because of a combination of flow noise and noise arising from cable vibrations. These high self-noise levels can be satisfactorily eliminated by using a slack cable system as described in the report.

1. Underwater Ambient Noise - Measurement
2. Underwater Sound - Measurement

I. Calderon, M. A.
II. Wenz, G. M.

SF 101 03 15, Task 8119
(NEL L20471)

This card is UNCLASSIFIED

Naval Undersea Warfare Center, San Diego, Calif.
TP 25

A PORTABLE, GENERAL-PURPOSE UNDERWATER SOUND MEASURING SYSTEM, by M. A. Calderon and G. M. Wenz, 46 p., 22 Dec 67.

UNCLASSIFIED

A portable underwater sound-pressure measuring system was developed and tested. The system was shown to be capable of measuring very low ambient-noise levels. High self-noise levels at frequencies less than 50 to 63 Hz are likely to be present if measurements are made from a drifting ship and the cable is towed at drift velocity, probably because of a combination of flow noise and noise arising from cable vibrations. These high self-noise levels can be satisfactorily eliminated by using a slack cable system as described in the report.

1. Underwater Ambient Noise - Measurement
2. Underwater Sound - Measurement

I. Calderon, M. A.
II. Wenz, G. M.

SF 101 03 15, Task 8119
(NEL L20471)

This card is UNCLASSIFIED

Naval Undersea Warfare Center, San Diego, Calif.
TP 25

A PORTABLE, GENERAL-PURPOSE UNDERWATER SOUND MEASURING SYSTEM, by M. A. Calderon and G. M. Wenz, 46 p., 22 Dec 67.

UNCLASSIFIED

A portable underwater sound-pressure measuring system was developed and tested. The system was shown to be capable of measuring very low ambient-noise levels. High self-noise levels at frequencies less than 50 to 63 Hz are likely to be present if measurements are made from a drifting ship and the cable is towed at drift velocity, probably because of a combination of flow noise and noise arising from cable vibrations. These high self-noise levels can be satisfactorily eliminated by using a slack cable system as described in the report.

1. Underwater Ambient Noise - Measurement
2. Underwater Sound - Measurement

I. Calderon, M. A.
II. Wenz, G. M.

SF 101 03 15, Task 8119
(NEL L20471)

This card is UNCLASSIFIED

1871