





THE LIBRARY  
OF  
THE UNIVERSITY  
OF CALIFORNIA

BEQUEST OF

Alice R. Hilgard

Digitized by the Internet Archive  
in 2007 with funding from  
Microsoft Corporation

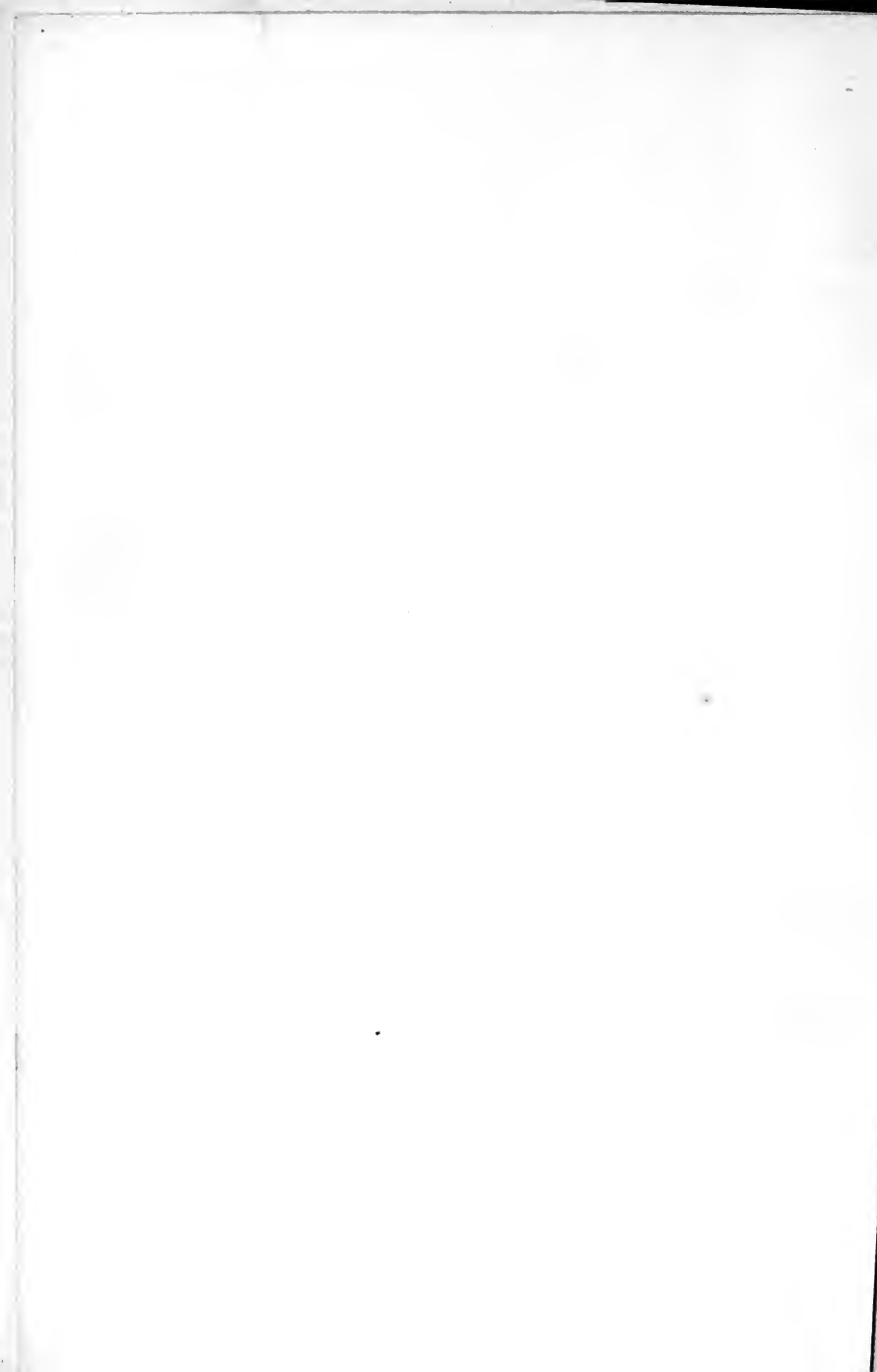

## POWER AND THE PLOW

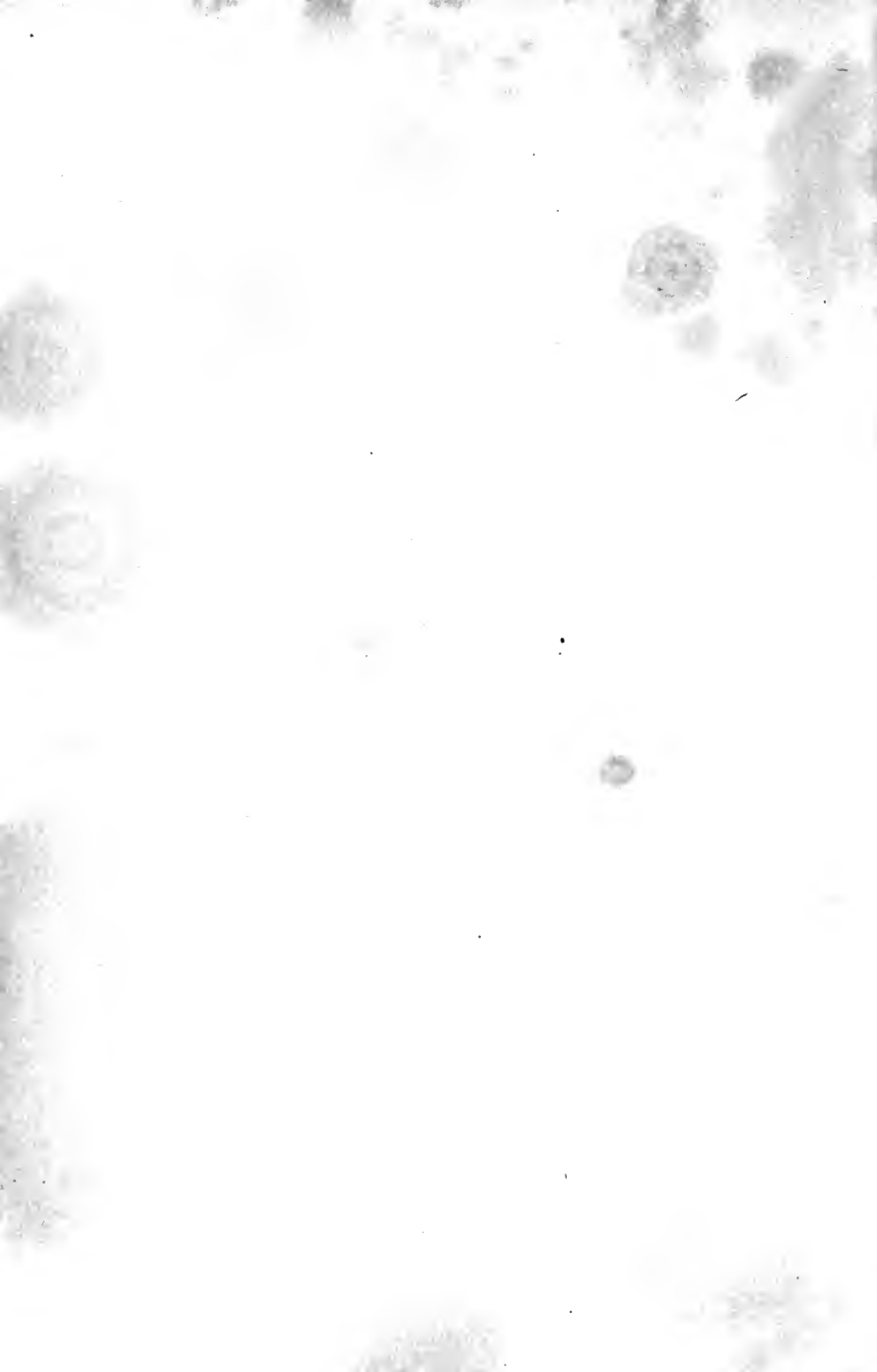



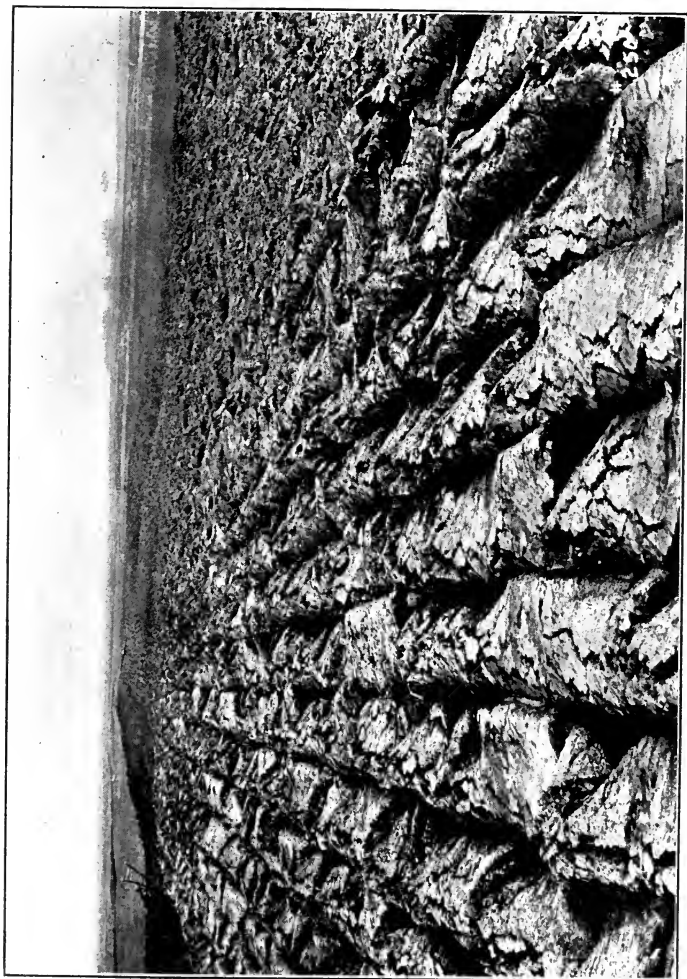

**THE WORK OF THE PLOW — THE GREATEST LABOR OF MANKIND**

Which consumes more power than all the factories of the world



# POWER AND THE PLOW

BY

L. W. ELLIS AND EDWARD A. RUMELY

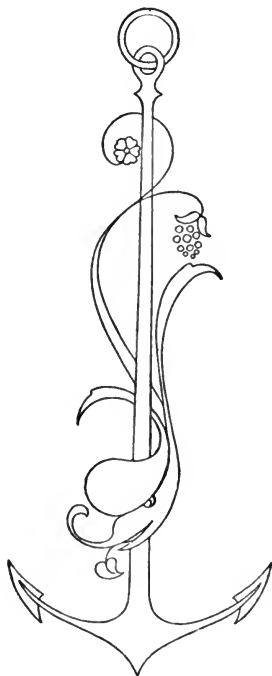

ILLUSTRATED

GARDEN CITY    NEW YORK  
DOUBLEDAY, PAGE & COMPANY  
1911

ALL RIGHTS RESERVED, INCLUDING THAT OF TRANSLATION  
INTO FOREIGN LANGUAGES, INCLUDING THE SCANDINAVIAN

COPYRIGHT, 1911, BY DOUBLEDAY, PAGE & COMPANY

GIFT

5683

E5

## NOTE

We are pleased to acknowledge our indebtedness for the illustrations in this publication to the International Harvester Co., Hart-Parr Co., Avery Co., Buffalo-Pitts. Co., Gas Traction Co., M. Rumely Co., C. L. Best Co., Holt Manufacturing Co., Thompson-Breese Co., Reeves & Co., J. I. Case Plow Works, Oliver Chilled Plow Works, Parlin & Orendorff Co., Moline Plow Co., Emerson-Brantingham Co., Deere & Co., La Crosse Plow Co., The American Thresherman, Modern Power.

M857972



## CONTENTS

CHAPTER	PAGE
I. The Motor Contest . . . . .	3
II. Sources of Power for Plowing . . . . .	12
III. The Measurement of Power . . . . .	15
IV. The Horse as a Motor for Plowing . . . . .	24
V. The Efficiency of the Horse . . . . .	32
VI. Essentials of the Draft Horse . . . . .	39
VII. The Steam Tractor as a Motor Power for Plowing . . . . .	41
VIII. Performance of Steam Tractors . . . . .	64
IX. Fuel for Steam Tractors . . . . .	71
X. The Internal-Combustion Tractor . . . . .	74
XI. Efficiency of Gas Tractors . . . . .	106
XII. Fuel for Gas Tractors . . . . .	112
XIII. Early History of the Plow . . . . .	130
XIV. The Plow in Great Britain . . . . .	134
XV. The Plow in America . . . . .	144
XVI. Plows for Animal Power . . . . .	159
XVII. Plows for Mechanical Power . . . . .	167
XVIII. Conditions Affecting the Choice of Plows . . . . .	183
XIX. Mechanical Principles of the Plow . . . . .	195
XX. When to Plow, and How Deep . . . . .	199
XXI. Draft of Plows . . . . .	206
XXII. Draft of Other Implements . . . . .	216
XXIII. The Genesis of Power Plowing . . . . .	222

## CONTENTS

CHAPTER		PAGE
XXIV.	Substitutes for the Tractor . . . .	226
XXV.	Animal-Mechanical Tillage . . . .	233
XXVI.	The General Purpose Motor . . . .	237
XXVII.	Business Management of Traction Plowing	243
XXVIII.	The Traction Engine in Dry-Farming . .	253
XXIX.	Traction Farming in Corn Belt . . . .	267
XXX.	Power and the Food Supply . . . .	274
XXXI.	The Choice of Power . . . .	289
XXXII.	The Future of the Traction Engine . . .	298
	Specifications of Leading Gas Tractors . .	309
	List of Authorities Consulted . . . .	317

## ILLUSTRATIONS

The Work of the Plow — The Greatest Labor of Mankind . . . . .	<i>Frontispiece</i>
	PAGE
At Motor Contests . . . . .	4
Sources of Power for Plowing . . . . .	12
Testing Tractors . . . . .	16
Steam Tractors . . . . .	42
Engine Power from Cultivating to Threshing . . . . .	44
Details of Steam Tractors . . . . .	46
Details of Steam Tractors . . . . .	48
Tractor Mishaps . . . . .	50
Gas Tractors . . . . .	76
Details of Gas Tractors . . . . .	78
Types of Gas Tractors . . . . .	80
Types of Gas Tractors . . . . .	82
Engine Gang Plows . . . . .	170
Engine Drawn Plows on Prairie Sod . . . . .	172
Hand Lift Engine Plows Working in Stubble . . . . .	176
Tractor Accomplishes All at Once . . . . .	184
Tractor Accomplishes All at Once . . . . .	186
The General Utility of Tractors . . . . .	216
Pioneers in Steam Plowing . . . . .	222
Saving Time by Good Management . . . . .	224
The Various Uses of the Traction Engine . . . . .	298





## POWER AND THE PLOW



# POWER AND THE PLOW

## I

### THE MOTOR CONTEST

**C**LOUDS of smoke and hissing steam; a broad prairie stretching for miles without a break, save for the distant mirage; here and there a tiny prairie fire held in leash by bands of blackened earth; dust and heat; throngs of eager spectators; the song of vibrant steel and the cracking roots of age-old sod — imagine all this, add to it the sight of a score of monster engines pulling leviathan plows, and you have a faint picture of the Winnipeg plowing contest. Shining prows of steel, cleaving the waves of a sea of prairie grass; long furrows lost in a haze; lines of fluttering flags to guide the engineer on a straight course; huge twenty-ton engines mere dots on the landscape, and you have the impression of distance. Refreshment tents, excursion trains, busy autos running errands for the slow-moving tractors, or whisking the manufacturer's crew back and forth, and you feel the spirit of a modern festival. Then, in the twilight, mild-eyed cattle meandering slowly over the upturned field, wondering, Rip Van Winkle-like, at the transformation, and you sense a tragedy, for the pasture of the ox and buffalo from time immemorial is lost forever to advancing civilization. In the night, when the camps have vanished, one might even fancy Indian spirits floating miserably over the desolate waste of a one-time happy hunting ground.

What is this affair? It is an annual contest, a feature of the Winnipeg Industrial Exhibition, open to the world for either steam or internal-combustion tractors of any size or weight. The contest of 1908, first of its kind on the American continent, was received with skepticism, admixed with wonder, but the world-wide interest in the results proved the timeliness of such a demonstration of the utility of mechanical power on the farm. With succeeding competitions this interest has in nowise abated, and the present scene is the crowning event of them all.

Invitations have been sent to every manufacturer, regulations drawn and published, testing apparatus put in readiness, and all preparations made to determine, from at least one standpoint, the best agricultural motor for Western Canada. For weeks before the trials engines have been arriving in Winnipeg, and many a neighboring farmer has had a sizable field plowed gratis while these modern farm horses tried out their paces. For ten long days before the engines appear on the plowing field they have been tested for their stationary power on a friction brake, in a hot unromantic corner of the exhibition grounds. Now they have made their way over ten miles of winding prairie trail to where a section of virgin gumbo sod lies waiting for the breaking plow. Here at last ensues the real struggle, the climax of a year's effort.

All one day there is the eagerness of preparation. Tents are pitched, fuel and water arranged for, plows assembled and carefully adjusted. On a quarter section set apart, the competitors are given a chance to test their plows and power. Courses are marked by flag and stake, and all made ready for the start at daybreak. In the night a steam tractioneer steals away with his engine to caulk a flue. Yonder a dim light shows where a torn gasket is being replaced on a gas tractor, or possibly a sheared stud in a fuel pump is being replaced by a nail from the tool-box. In the stillness, the sound of a stealthy file betrays the purpose of a plowman to get an edge on his rival as well as his plow. Camp food, tents, cots, blankets, hasty lunches

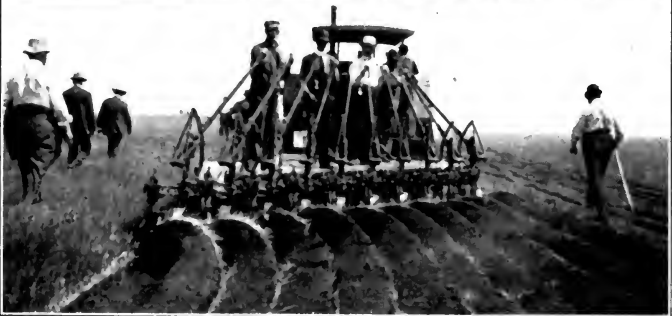

### AT MOTOR CONTESTS

The first in America held at Winnipeg, Can., in 1908

The gasoline midget

Making smooth, mile-long furrows ten at a time



during the long busy hours, the lack of opportunity for restful sleep and clean washing, all emphasize the bustle and confusion, and give some hint of the hardships borne without a murmur by the loyal mechanics. Their iron steeds have been put in the final pink of condition. The night before the supreme test the men sleep in their clothes on the field, one eye open for prowlers from rival camps.

Out on the fields at dawn we find the officials, business-like college professors, clad in wide-brimmed hats and overalls. Harassed and buffeted by contending ranks, they discharge their duties with all the more zest. Fuel and water are carefully dispensed, and one by one the puffing, purring steamers and the pattering gas tractors are sent into the fray. Down the field, headed straight for each flag in the line, the steersman strikes his furrow. Circling quickly at the other end, he returns carefully upon the edge of the first. Back and forth the engines puff and groan, while plowshares that have been sharpened to a razor edge at the factory cut the tough, dry sod as a knife cuts cheese. Two acres of virgin prairie grow dark with every mile of travel, four acres in an hour. Once in a former contest an acre of stubble ground was plowed in eight minutes, a world's record. Tons of coal and carloads of water are sent into the thin air, and between sunrise of one day and nightfall of the next three hundred and twenty acres of virgin land are doubled in value by breaking.

Here is a mammoth steam engine of the double-cylinder type; there a single cylinder. Yonder is an engine which has been used until bearings are worn to a glassy smoothness and every joint is limber. Next to it is one losing hopelessly through lack of preliminary tuning up. Alongside a steam mogul is a gasoline midget. On the next course is the hope of an inventor who has staked his all on a crude combination of plows, harrows, and packers. A fussy little single-cylinder engine is coughing, "I can't, I can't, I *can*, I *can*, I *can*, I can't, I can't." Yonder can be seen a gas tractor with opposed engine, here a four-

cylinder vertical, and over there a two-cylinder horizontal. This engine cools its cylinder with water, and that with oil. This one has a hit-and-miss governor, while that one throttles its charge. Here is an owner ready at the last moment to risk the race on some new notion. A new cleat or a new cork insert in the friction clutch fails at the critical time and a good machine is discredited. The student of design saves here ten thousand miles of travel, and sees construction put to its most strenuous test in yielding data of incomparable value.

Each hour the steamers must take water, but time is too precious to allow a stop. The tank wagon keeps pace alongside, and a hose-crane and steam jet do the rest. Once in two hours the coal supply must be replenished, but the engineer finds sacked fuel and a dozen helping hands to avoid delay. The bare prairie affords no natural watering place. The alkali water from a distant farm well is not only insufficient, but bad for both man and machine. The railway falters in its task of bringing water in tank cars from the city, and early in the day six steamers must stop plowing while gas engines on all sides go popping merrily on. When water comes at last, two versatile gas tractors fall to and assist the weary teams in keeping their steam cousins in motion.

The foremost experts on the continent are in charge of rival plows. Here is a game within a game, Yankee plowmaker against Yankee, and Canadian against both. The craftiest general of them all adjusts his plows to show a sharp furrow handsome on top, regardless of what lies underneath, and so wins popular favor for the engine which tows him. Had the plowmaker not provided these superb implements, products of the last decade, a contest on such scale would be impossible. The cattle wandering over their former pasture field would still have found rich pickings, and the memory of smooth mile-long furrows would not have lingered with many a farmer to create in his mind the thought of ownership.

In immediate charge for the competing companies are the tall



diplomatic manager of an experimental department, trained as a salesman; the untechnical publicity man; the mechanical engineer and the chief inspector of one concern; the shop superintendent of another, and the Canadian sales-manager in another case. An intensely interested gallery follows every move. The head of a great company meets fifty subordinates on the field. In one short day he progresses from vast ignorance of even the commonest terms to a masterly grasp of the stupendous opportunity pictured by this brief contest. A veteran builder proclaims his impatience with a contest that pays him nothing for the expense and worry, yet down in his heart he knows he could not be kept out. A bluff man, risen from the rank of salesman to the leadership of an immense concern, is deep in conversation with an eager young officer who has brought an old company in the states a new lease of life. At some lull an eavesdropper finds them betting a hat on the result of the contest. The next moment they plunge into a discussion of what manufacturers can do to prevent the impending shortage of skilled labor, which must cripple us as a manufacturing nation. Astride a water tank, and losing no detail of the proceedings, is the dapper, rosy-faced man who rules one of the largest thresher companies with an iron hand. In a buggy that seems strangely out of place follows an elderly, mild-mannered man who has brought his new engine to the motor contest to give it a tryout such as he is unable to give it at the factory.

The professor of mechanical engineering rubs elbows with professors of agricultural engineering. The superintendent of motive power in a great railway system exchanges views on traction dynamometers with the inventor of the ones used in the contest. In a sociable group are government representatives from Russia, Canada, and the United States, and a half dozen non-competing manufacturers from the world-at-large. There are scores of men building steam and gas tractors; stationary gas engine builders whose mouths water at the dream of

a profitable tractor trade; men building plows; and, besetting all these, dozens of inventors who are there to gather ideas and present their claims for the attention of capital.

By machine, trap, and excursion train come the crowds. Sharply through it all runs the commercial spirit. On every hand is the wily salesman bidding for the favor of a fascinated prospect. Here is the farmer who comes with open mind, and there is the partisan who backs his favorite, win or lose. Yonder is he who came to scoff and remains to investigate. Well-groomed city men and smartly dressed women come, in uncomprehending wonderment, to join the throng that trudges after these roaring, pulsating heralds of a new order of things on the farm. From far and near the Canadian farmer, and even his neighbor from across the line, flock to Winnipeg to see the tractors of the English-speaking world pitted in equal competition. Representatives of the press are everywhere at elbow to note the smallest item of interest. On every side there is the indefatigable photographer, and even the cartoonist, gathering pictures of the engines, the plows, and the living actors for the eyes of a waiting world.

What does the public comprehend of the immense spectacle staged for its benefit? What does it know of the game, the intense rivalry, the tricks, and the prize that is sought? In the eyes of the farm boy you see only the look of envy cast on the greasy mechanic at the throttle or steering wheel. You fathom the longing of a weary farmer to own a machine which banishes drudgery. But the participants themselves, intent only on their own and some rival's performance, have neither eyes to see nor lips to explain. No actors were ever more careless of their audience, at least until the contest is over, and the advertising managers of the successful firms get busy.

Influential men from the largest oil corporation in the world are present, keenly interested in the question of mechanical power on the farm as affecting the market for liquid fuels. The largest independent maker of automobiles, prepared to spend

untold amounts in developing his ideas of a light farm tractor, is here to study and criticise. He finds a kindred spirit in the old patent expert who illustrates his conception of the light tractor by the story of a cat chased up a tree by a dog. "The cat," he says, "didn't have weight, but she had traction." An unsympathetic bystander suggests that if a brick had been tied to the cat's tail, corresponding to the plows behind a tractor, the dog would have put the cat out of business.

No other annual exposition held on the American continent brings together such a galaxy of big men in the farm power industry as the Winnipeg exhibition with its motor contest. No other one thing has done more to crystallize the thought of the world upon the adaptation of mechanical power to plowing. The capital and brains of a continent are concentrated at one point, all intent on the one problem. Capitalists, engineers, designers, salesmen, journalists, land men, oil men, farmers, and teachers are all on the scene, striving to forecast the future of mechanical power on the farm. Through this one annual event the name of Winnipeg has become so linked with the thought of traction engines and traction plowing that, when the last great history of mechanical power on the farm shall have been written, the name will stand out on the pages like that of Chicago in the romance of the reaper, and South Bend and Malone in the history of the plow.

What is there behind all this? Are we watching a mere parade of machines, or is it a race, with huge, slow-moving iron Percherons in place of thoroughbreds? As ages of racing have put fire and steel into structures of muscle and bone, as auto races have toughened the metal of machines, so does the contest bring out the temper of the contesting motors. It is a race where twenty-ton engines are the entries, where the skill of the designer, the craft of the workman, the cunning of the general on the field, and the coolness, bravery, and resourcefulness of the tractioneer are all pitted against those of rival houses.

Let no one liken the motor contest merely to an old-time Scottish plowing match, where slow, careful work, a steady team, and a skilful hand were the winning factors. The Scotchman aspired to leave behind him smooth furrows, straight as an arrow, with the crest of each standing up sharp and unbroken from one end of the field to the other. Here at Winnipeg, where all is speed, distance, and bustle, we might more easily liken the scene to a hunt. We might call it a sport of kings, where men spend thousands to win a golden bauble. A bauble, did we say? Yes, and no, for the medal carries with it a claim on the lion's share of trade in a new farm empire richer than Ind.

Fifty important firms on this continent are building tractors. A million-dollar addition in Indiana, a new million-dollar plant in Chicago, a two-million-dollar factory in Iowa, have been erected to construct gas tractors in the brief interval since they have been recognized as a possibility. New companies are appearing, old firms expanding, to take care of the business that rewards aggressive methods. The Northwest is the battle ground. Machine power is on the ascendant. You hear it, see it everywhere. Farmers and business men talk it. Salesmen breathe it. A single issue of a Canadian magazine contains 16,000 agate lines of reading matter and 20,000 of advertising devoted to power plowing. In Western Canada two hundred million acres of tillable land lie in a virgin state, waiting for power and the plow, and trainload after trainload of tractors, bedecked and bannered, are pouring from the East and the South, through the Winnipeg gateway, and on to the wide aces of Alberta and Saskatchewan to answer the call.

Here is the fascination of the Winnipeg motor contest. We are witnessing in miniature the conquest of the last great West, a fit occupation for the strong. Broad, free stretches of virgin land, so large as to dishearten the lone settler, offer a problem to test the mettle of the keenest and the most powerful. Mechanical power has added tens of millions of bushels

yearly to the yield of prairie wheat and put hundreds of prosperous towns on the map. Prairies are now settled in months where it took years before the coming of the traction engine. The Man with the Hoe is passing, and, in his wake, man's faithful friend the horse.

Wheat is the noblest of all foodstuffs, containing in its kernel the thirteen essential elements of animal nutrition in almost the exact proportions found in the human body. Once a race has tasted wheat it begins to rise in the scale of civilization. The civilizing influence of commerce has created an appetite among the people of all lands, and drawn with increasing force upon the surplus of exporting nations. The world is pressing on the limits of wheat production, and actual shortage is imminent unless we can push rapidly into virgin fields in search of a larger wheat-raising area. Canada, Russia, and the Argentine are wresting from the older nations the right to supply the world with bread. Broad, level tracts, unhampered by petty farm lines and traditions, together with unlimited mechanical power, offer the opportunity for organizing wheat production on a broad and effective basis. Every horse displaced by mechanical power adds five to eight acres to the area devoted to human maintenance. Back of the motor contest, then, and giving it force, is the call for the taming of the prairies, and, deeper than that, the cry of increasing millions for an abundance of their daily bread.

## II

### SOURCES OF POWER FOR PLOWING

**M**AN has risen in the scale of civilization in exact proportion to the extent to which his brain has devised means of lessening physical work. From the time that practical necessity pulled the Sacred Bull off his high pedestal, and lashed to his horns the long branch of a forked sapling, man has accomplished the world's work with less and less drudgery. First the weaker human beings, then the more powerful though less cunning animals, and finally, one by one, the great forces of nature, have been brought under man's control, harnessed, and made to do work. Man has attained wondrous mental power and a capacity for work that is impossible to the unaided hand. The brain has accomplished what the arm and hand never attempted, converting the power of the sunshine into blessings for the human race.

The sun is the original source of all energy used on this earth. The steam engine, the gas engine, the windmill, the water-wheel, the draft horse, and man himself are all prime movers to make use of the sun-power which comes to us in widely different natural forms. Steam and hot-air engines burn coal or oil, which contains the energy stored from sunshine in prehistoric vegetation, or wood and straw of more recent growth. The gas engine burns alcohol, which was stored up in the plants of this year's growing, or else products of coal and crude petroleum, which contain the power of the sun of past ages. The sun heats different portions of the earth's sur-

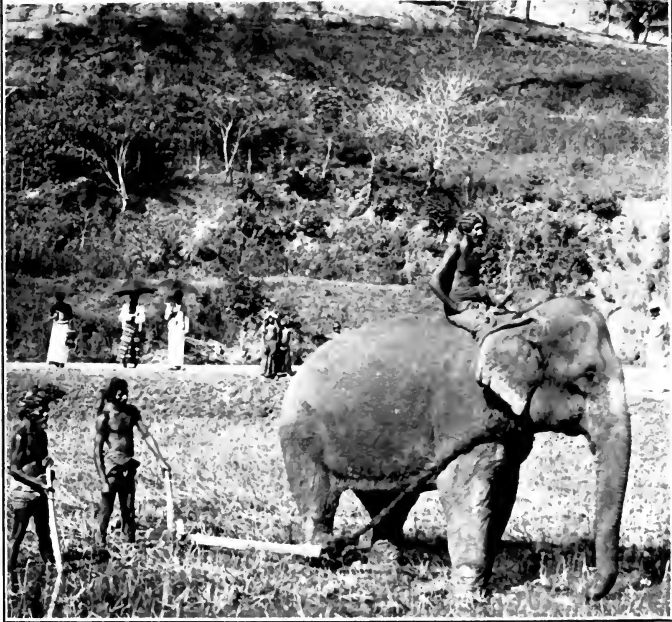

Photograph by Underwood and Underwood

## SOURCES OF POWER FOR PLOWING

Doukhobor women in Canada

The Elephant in Ceylon





face unevenly, and sets up air currents, which drive our wind-mills. It lifts water from the sea and drops it on the mountain tops. On its course back to the ocean the stream drives the water-wheel. The newly invented solar motor derives its power from the sun's rays, which it intercepts directly. Man and the draft horse obtain their power through assimilating the energy which the sun stores up each year in plants. Even the feeble wave motors are agitated by forces of which the sun is the centre.

In the ordinary classification the electric motor is included, but it is not, strictly speaking, a prime mover, since it merely transforms into mechanical energy the electric current which has been derived from another source. The windmill, the water-wheel, and the wave motor intercept the motion of air or water in the mass and may be called *gravity*, or *kinetic* motors. The heat engines, by supplying the conditions for the oxidation of fuel, convert it into heat, thence into work. They derive power from the chemical changes that are produced and have been called *chemical* motors. These are by far the most important with which we have to deal. Possibly the most stupendous discovery in the history of the world was that the heat from burning materials could be made to do the work of men and animals.

It is our intention to devote space only to those motors used for plowing, hence we shall pass over wind, wave, water, solar, and hot air motors with a mere mention and discuss the electric motor briefly, in its proper order. The world over, the animal is most common motor for plowing. Human labor is still put to this wasteful use in a few countries, including even Japan and modern Switzerland. In all countries, however, which are not so densely populated as to make live stock raising practically out of the question, the inhabitants have substituted brute labor for human muscle. The picturesque water buffalo is the common beast of burden in the Phillipines, both for agriculture and transportation. In the land of the Pharaohs

and in Asia Minor, the "Ship of the Desert" is made to turn the inland soil.

The ox is the major source of power in Mexico, Central and South America, and in many of the rough and stony portions of the coast countries. We find him often on the Western plains, relieving the shortage of power. The ox is still better adapted to some conditions of work than the horse. He is deservedly popular among the rocky hills of New England, where docility, slow but powerful movement, and a sure foot are valuable characteristics. On the other hand, the steer at work moves at about two thirds the speed of the ordinary farm horse, and pulls only an equal load. He is not adapted to a faster pace for quick transportation, and was long ago dethroned by the swifter horse. South of Mason and Dixon's line the mule and the ox probably equal the horse in numbers. However, in the United States as a whole, the horse far outnumbered all other beasts of burden and may be considered as the standard draft animal.

After a struggle of forty years the traction engine has found a permanent place in the plowing field. We now find American traction engines plowing large areas in our own West, in Canada, Russia, and the Argentine. English steam tractors have long been in use in all parts of the world. Steam engines in use for plowing undoubtedly outnumber gas tractors, even in North America, where the latter have been increasing most rapidly in numbers. But the internal combustion, or gas, tractor is coming rapidly into favor, and possibly this year, for the first time, its sale will surpass that of the steam tractor in the plowing field. The majority of gas tractors built are now used for plowing, whereas many small steam tractors are built simply for threshing in the Central and Eastern states. The use of the electric motor for plowing is as yet confined to a few isolated localities in Europe, notably in Germany and Italy.

### III

## THE MEASUREMENT OF POWER

**I**N DISCUSSING motors and power it is convenient to use engineering terms which are not in general use in ordinary literature. That portion of the subject of dynamics which treats of the measurement of power is therefore touched upon briefly in the definitions included in this chapter.

*Force* is any cause which tends to produce a change in the motion of one body with respect to another, either in rate or direction. All bodies above the earth tend to approach it in obedience to the force of gravity. To lift a body, an outside force must be applied to overcome the gravitational force. The resistance offered by the action of gravity may be measured by noting the ability of various amounts of any substance to compress or extend springs of a given size and material, or in other ways. The unit of measurement of gravitational force, or weight for English-speaking countries, is the *pound weight avoirdupois*, which is the weight, or resistance to a lifting force, of a certain mass of platinum, preserved in the office of the exchequer in London.

*Work* is produced when a force acts to move a body through some distance in opposition to resistance: The resistance, for example, may be that of gravity; of friction, as when a body is dragged over the ground or a mass of machinery is made to move in spite of the adhesion between the metals in contact; inertia, as when a body is first put in motion or its rate or

motion changed; or of tension, as when a spring is compressed or extended beyond its normal state.

In English-speaking countries the standard measure of distance is the British standard yard, which is the distance at a temperature of 62° F. between two marks on a certain bar of bronze, deposited in the British office of the exchequer. The usual measure of distance is one third of the yard or one *foot*.

If a force of one pound is exerted, either in lifting a pound weight or in overcoming an equal resistance in a lateral direction and this force be exerted through a distance of one foot, the work done is the product of force times distance, or one *foot-pound*. This is the common unit for the measurement of work, though in the same way we might have other units such as "inch-pounds" or "foot-tons." The common term "ton-mile" is not to be confused with these. The ton-mile is simply the moving of a weight of one ton over the distance of one mile on the surface, or the equivalent of this result, regardless of the fact that more work will be required at one time to produce a ton-mile than another, owing to the varying resistance offered by different vehicles and road surfaces.

*Energy* is the ability to do work. In compressing a spring a certain force acts through a certain distance, the product being a definite quantity of work. The spring becomes endowed with energy, which has been stored up at the expense of the force which compressed it, and is then able to do work on another body. The crankshaft of an engine can be made to revolve by means of the energy transmitted through the piston, and in turn will give off work to other masses. Work will be required to lift water to a given height, but work can be recovered from it as it flows to a lower level. Energy is the equivalent of work in a potential state. Any form of energy can be transformed into any other form. Thus, a fuel which contains a chemical energy can be burned under a boiler to produce heat energy. This heat may be transformed by a

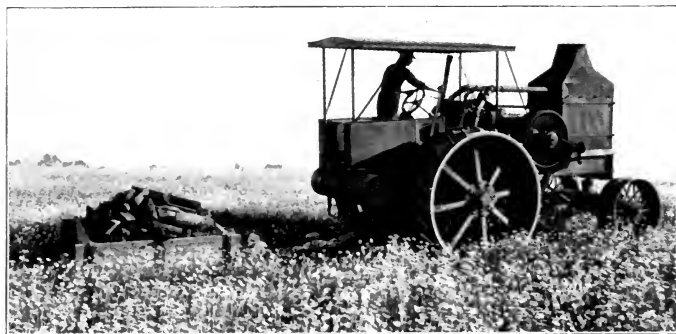
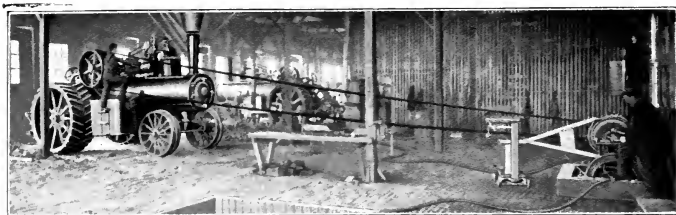

## TESTING TRACTORS

Brake test

Dynamometer test

Hill-climbing



piston and cylinder into mechanical energy for turning the generator. The generator will produce heat, which will return into the air, whence it originally came. Energy is never lost nor destroyed, but at each step in the foregoing cycle, some may be transformed into heat and escape without doing useful work. When energy is expended by a certain agent, some other material inevitably receives energy in the shape of work or otherwise, the total being exactly equal to the energy stored in the original source.

The toy engine may in time produce many millions of foot-pounds of work. The large engine in a central power plant may do an equal amount with a few strokes of the piston. In order to make a comparison of engines we must bring in the element of time — *i. e.*, the unit of *power* must take into account not only the amount of work done but the rate of doing it. The unit of power accepted in English-speaking countries is the *horsepower* (h. p.), which represents a power output of 550 foot-pounds of work per second, or 33,000 foot-pounds of work per minute. This might be done by lifting a weight of 1100 pounds one foot in two seconds, or 275 pounds two feet in one second, or some such equivalent. The product of force times distance, divided by time, will always equal 550 foot-pounds per second, for each horsepower. One horsepower exerted for the period of one hour gives rise to another unit of work known as the *horsepower hour* (h. p.-hr.) is frequently used in determining the fuel efficiency of a motor.

Every engine will waste a certain amount of energy in overcoming friction within itself, besides the waste involved in transforming energy from the chemical to the mechanical state. Of the power generated in an engine cylinder, from 2 to 25 per cent. may be lost as compared with the work which will be done at the flywheel. Of the latter amount still another portion will be lost in a traction engine in overcoming the friction in the transmission system, and in moving

the weight of the tractor itself over various grades and surfaces. In order to compare these various losses a number of tests have been adopted to determine the efficiency of the engine in various particulars.

The work done in the engine cylinder is known as the *indicated* horsepower (i. h. p.). It is always less than the energy which is supplied to the engine in the shape of fuel. In the steam engine the first losses occur in unburned gases and bits of carbon that pass out of the chimney; in unconsumed fuel in the ashes; and in radiation from the boiler, steam pipes, and the cylinder itself. The indicated power is calculated by the aid of an apparatus known as the *indicator*. This consists of a small cylinder containing a piston and spring; a larger cylinder or drum for holding a sheet upon which a record may be traced; and mechanisms for controlling the movements of the recording pencil and the drum. The piston of the indicator, which is usually one inch in area, is exposed directly to the pressure within the cylinder by means of a pipe connection. The pressure on the piston compresses a spring, the resistance of which has been calibrated by determining the number of pounds neces-

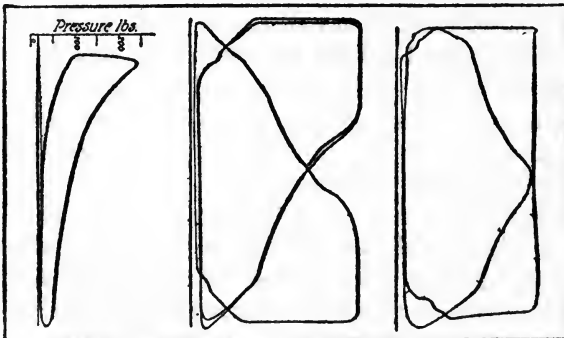

Indicator cards from actual charts of steam and gas engines

sary to compress it one inch in length. A reducing movement connected to some reciprocating part of the engine, such as



the cross-head, rotates the drum on which the record sheet is placed in exact accord with, and in proportion to, the movement of the piston of the engine. The pencil is raised and lowered vertically by the movement of the indicator piston. The resulting diagram on the recording sheet is what is known as an *indicator card*, the area of which in inches, divided by the length, and multiplied by the resistance of the spring, gives the average pressure per square inch during the working stroke.

Since the pressure is known and the area of the piston can be calculated from the diameter, it is necessary only to know the length of the piston stroke in feet to get the foot-pounds of work produced at each stroke. By applying a revolution counter or speed indicator to the flywheel of the engine we may determine the number of revolutions per minute. In the steam engine two power strokes are made to each revolution of the flywheel. In the ordinary four-cycle, throttling-governed, single-acting type of gas engine, there is but one power stroke to two revolutions of the flywheel. In some types, the number of explosions is still less, and must be counted in some manner, in order to determine the number per minute. The foot-pounds of work at each stroke, multiplied by the number of power strokes per minute, gives us accurately the amount of power developed in the cylinder. The formula for i.h.p. is:

$$\text{i. h. p.} = \frac{2P \times L \times A \times N}{33,000}$$

in the case of the steam engine, and

$$\frac{P \times L \times A \times N}{(33,000 \times 2)}$$

in the case of the four-cycle, single-acting, throttling-governed gas engine, in which  $P$  = mean effective pressure, (m.e.p.) in pounds per square inch during the working stroke;  $L$  = length of piston stroke, in feet;  $A$  = area of piston in square inches, and  $N$  = number of revolutions of flywheel per minute.

In determining the power at the flywheel of an engine,

what is known as a brake test is made. To the flywheel is clamped a *friction brake*, from which extends a long arm, which is usually supported by a column resting on a platform scale. This arm has the effect of increasing the diameter of the flywheel. The flywheel must revolve against the resistance offered by the brake. The brake arm also tends to revolve and is prevented from doing so, the force required to support it being expressed in pounds upon the beam of the scale. The result produced is that of a certain resistance in pounds, moving at a rate equivalent to the speed of the flywheel, times the circumference of a circle which has as a radius the length of the arm from the centre of the flywheel to the point of support at the outer end.

By formula, the *brake horsepower* (b.h.p.) equals:

$$\text{Circumference } \frac{(2 \times L \times 3.1416) \times N \times F}{33,000}$$

in which  $L$  = distance in feet from the centre of the crankshaft to the point of support for the outer end of the brake arm;  $N$  = number of revolutions of the flywheel per minute; and  $F$  = weight shown on the scale beam.

The b.h.p. must always be less than the i.h.p., due to the friction of the valves, piston, bearings, etc. The best engine is naturally the one which wastes the least power in developing work. For comparison, engineers use a term, *mechanical efficiency*, which indicates the percentage of the indicated horsepower delivered by the flywheel in a brake test such as just described. In the highest type of steam engines this is sometimes 98 per cent. More often it is 85 to 93 per cent., and frequently as low as 75 per cent. In the gas engines of smaller type the mechanical efficiency is somewhat lower, ranging from 75 to 85 per cent., with occasional records of 90 to 93 per cent. in large stationary plants.

In plowing with ordinary equipment, the best tractor is one which will deliver the largest percentage of its brake h.p. at the drawbar, all other things being equal. In other

words, a plowing tractor should have the highest possible tractive efficiency consistent with other vital features. Tractive efficiency is properly estimated on the basis of the ratio between the drawbar, or tractive horsepower and the brake h.p.

Tractive horsepower is ascertained by noting the speed of travel and determining the resistance of the load by means of a *traction dynamometer*. This instrument consists fundamentally of a calibrated spring which may be attached between the engine and its load. The tension on the spring causes it to move a pointer upon a dial that is graduated to show the resistance in pounds. There may also be a mechanism operated by clockwork for driving a graduated tape at a speed proportioned to the duration of the test. A recording pencil attached to the pointer traces an irregular autograph, the average distance of which above the base line gives the average draft during the tests. The distance traveled in a given time, together with the resistance, gives the tractive h.p. For example: A tractor moving at the rate of two miles per hour, travels in one hour 10,560 feet, or 176 feet per minute. If the average resistance or draft is 7,500 pounds, then in one minute the tractor does 1,320,000 foot-pounds of work. This divided by 33,000 gives 40 h. p. as a result. By cancellation of constant factors we arrive at a much shorter formula, which is: Speed in miles per hour  $\times$  drawbar pull  $\div$  375 = tractive h.p.

The object of a heat engine is to convert the chemical energy of the fuel into mechanical energy. All other things being equal, the most efficient motor is the one which will deliver the largest amount of this energy as useful work. In order to compare engines in this respect it is necessary to reduce the energy supplied in the fuel and in the work recovered to the same basis and thus determine the *thermal efficiency* of the motor. In order to determine the heat value of different fuels, engineers have adopted units of comparison. For English-speaking countries the standard is the *British thermal unit* (B.t.u.), which is the amount of heat necessary to raise the temperature

of one pound of pure water from  $62^{\circ}$  to  $63^{\circ}$  F. The amount of heat units in fuel or food can be determined by exploding a given quantity in a bomb-like vessel known as the calorimeter, and noting the rise in temperature of a measured quality of water surrounding the vessel. The calorimeter derives its name from the French heat unit, the *calorie*. This represents the amount of heat to raise one kilogram of water (2.2.pounds) one degree on the Centigrade scale, or 1.8 degrees Fahrenheit.

By careful experiments, it has been found that one B.t.u. is equivalent to 778 foot-pounds of work. In other words, the energy required to raise one pound of water one degree Fahrenheit in temperature is equivalent to the energy required to lift a weight of 778 pounds one foot vertically. One calorie, then, is equivalent to 3.97 B.t.u., or 3090 foot-pounds of work. Since the energy delivered by an engine and the energy in the fuel may thus be reduced to a common basis, it is possible to determine the proportion of the heat that has been recovered in work.

For example: Let us assume that an internal-combustion engine delivers 1 h.p. at the flywheel for the period of one hour for every pint of kerosene consumed. By previous calculations we have found that a pound of this fuel contains 20,000 B.t.u. and that the fuel weighs 6.7 pounds per gallon or .8375 pound per pint. Then for each h.p.-hr. of work recovered we will supply to the engine  $.8375 \times 20,000$ , or 16,750 B.t.u., equivalent to 13,031,500 foot-pounds of energy. In one h.p.-hr. there are  $33,000 \times 60 = 1,980,000$  foot-pounds of work. The ratio of foot-pounds of fuel energy supplied to foot-pounds of work recovered is, therefore, 1:0.152, which is equivalent to a thermal efficiency of 15.2 per cent. The thermal efficiency of an internal-combustion engine usually ranges from 12 to 25 per cent., though an efficiency of 37 per cent. has been realized. Steam engines in large central plants, even of a compound condensing type, seldom reach a thermal efficiency higher than 12 per cent. A steam traction engine under the best conditions

will seldom show a thermal efficiency higher than from 4 to 6 per cent.

In the case of the steam engine there is still another efficiency which is frequently cited — *i. e.*, *boiler efficiency*. Under ordinary conditions the traction engine boiler, which usually works in an exposed place with none too perfect insulation, has an efficiency of 50 to 55 per cent. In stationary engine practice the boiler efficiency often ranges from 65 to 75 per cent. This means that of the heat which is supposed to be generated by burning fuel in the fire box, from 50 to 75 per cent, is absorbed by the water. The efficiency, of course, will vary widely with the type of boiler, the protection, the quality of water used, and whether or not salts from the water have been allowed to form a scale upon the flues and other surfaces exposed to the heat of the fire.

## IV

### THE HORSE AS A MOTOR FOR PLOWING

**I**F WE look backward we will find the first horse a five-toed animal, no larger than a dog, paddling about in the marshes. With the drying up of the swamps he became a land animal, losing a part of his toes. In the wild state he was obliged to procure his own food and protect himself from his enemies. The weakest were eliminated by natural selection, and gradually the race increased in size and swiftness. Many habits, instincts, and characteristics developed during ages of the survival of the fittest are not essential in the domesticated horse, but still endure to affect the efficiency of the animal in its present field.

The present-day farm horse is largely a man-made product. Starting with the wild horse, man has molded the animal to suit his various needs. He has taken it out of its wild environment, given it food and shelter, protected it from its natural enemies, lengthened its life by breeding from the hardiest stock, and by studying how to conserve its health and strength. He has studied its possibilities, made use of its natural characteristics, has produced widely divergent forms each fitted for a special purpose. However in nature, selection was slow, often accidental. Under man's influence the process has been only a little faster. Defects could be recognized and eliminated, but only by the slow process of mating and waiting for results. A fortunate breeder, starting with the best of stock, could not take over a dozen steps in advance in the course of a lifetime. The death of the best individuals

might wipe out the work of years, and so could a seemingly capricious reversion to an abnormal or inferior type. Nevertheless, the accumulated improvement of ages of natural selection, thousands of years of selection by man, and two and a half centuries of scientific breeding, has resulted in a class of animal motors suitable for all farm work, great in numbers and value, and understood, almost by instinct, by every farmer in civilized countries.

The earliest record of man's use of the horse occurs in the Bible. Apparently the horse was domesticated in Egypt, about 1740 B. C., and first used for the purposes of war. Three hundred years later, horse races were among the sports at the Olympian games, in Athens. Troops of wild horses in Tartary and in South America were first used for food, and then saddled. Although the prehistoric horse existed in North America, the modern type in its wild state undoubtedly springs from horses which were loosed by the earliest Spanish explorers. History shows that the business of war and conquest have done more to distribute the horse over the earth than commerce. Horses were fit chattels only for kings in the palmy days of Egypt, and even as late as the tenth century, farmers in England were forbidden, by law, to harness the horse to the plow. The ancient Anglo-Saxon and Welsh records contain no reference to the plow horse, and the first notice of his use in field labor is given by a piece of tapestry, woven at Bayonne in the time of William the Conqueror. Even then he was attached to a light-running harrow. Now, and ever since the early decades of the nineteenth century, the horse has shouldered the burden of plowing, which fell upon the ox and the ass long before the Christian Era.

The greatest and most lasting improvement of the horse came from deliberate crossing and selection. Robert Bakewell, in England, rendered enduring service by his improvement of the English cart horse, and founded on his work, we now have wonderful draft breeds, each revealing a certain ideal.

The Percheron, Clydesdale, Belgian, Shire, and Suffolk are the most prominent in England and America, the Percheron being by far the most popular.

The heavy horse of Flanders was crossed with beautiful Arabs, taken from the Saracens at Tours, in 732 A. D., after the world's greatest battle. To this mating we owe the modern Percheron, whose fire, beauty, action, and massive utility have carried him to the front. Along the Clyde, we think of the bagpipe and the Scottish Lowlands, where his strong, lanky frame, his rapid, easy action, and his endurance on long hauls have made him popular. The Shire is descended from the low-built English war horse, which even the Romans were forced to admire when they landed in Great Britain under Cæsar. He is now best adapted for slow, heavy work. The Belgian is a direct descendant of the old horse of Flanders. He, too, is heavy, massive, stocky, and adapted to slow, heavy work in a congested city thoroughfare. The Suffolk is muscular, active, durable, of lighter weight, and especially adapted for rather diversified farm purposes. These breeds have all been widely used for crossing with grade stock to produce more efficient motors. In America the bulk of the improvement of the native horse has been effected since the importation in 1851 of Louis Napoleon, the first great Percheron stallion imported.

It is obviously impossible to consider the horse simply as a machine, since in nature he is self-feeding, self-controlling, self-repairing unless seriously injured, and self-reproducing — functions of which the ordinary traction engine is incapable. Certain disadvantages, however, tend to offset these good qualities, such as the necessity for education prior to usefulness; frequent attention if confined; shelter from heat and cold, as well as from rain and snow; variety of foods; frequent rest; protection from disease and other enemies; and use in comparatively small power-units. Theoretically, according to Thurston, the animal is not a heat engine.



Practically, we are concerned with the recovery in the shape of useful work of the largest possible percentage of heat units supplied to any motor, and on this basis, at least, the horse and the machine may be brought into direct comparison.

#### THE MECHANISM OF THE HORSE

The animal mechanism is composed of (1) bones, which constitute a connected system of levers, with automatically lubricated joints; (2) muscles attached in pairs to these levers so as to resemble a series of independent motors capable of producing an alternating or reciprocating movement, like that of an engine piston; (3) organs of digestion, respiration and excretion for supplying fuel and removing waste, perhaps analogous to the automatic mechanical stoker and ash conveyor; (4) a brain and nervous system for regulating the action of the muscle motors, much as a battleship is governed by electric signals to and from the conning-tower; (5) a covering of skin and hair, like a dust-proof crank case, protecting all working parts from outside influences, and conserving and radiating heat.

The muscles, with which we are most concerned, are made up of bundles of fibers. Under the stimulus that come from the nervous system, these fibers have the power of contracting, but only through a short distance. For this reason they must work on the short ends of the bony levers in order to move them rapidly through space. In the human biceps, as measured by Professor King, the ratio of the long and short lever arms is as great as 6 to 1, hence to lift a weight of 50 pounds the muscle must exert a pull of 300 pounds on the shot end of the lever. Unlike the human body, which is best adapted to lifting and carrying weights, the



Muscling of a horse's leg

horse's frame and weight are better disposed to dragging loads over the surface of the ground.

The fuel of the animal motor is in the shape of hay and grains. These contain various heat-producing constituents which, in order to become available as energy, must be transformed in the animal body into muscular tissue. Of the various grains, the horse can digest from 70 to 80 per cent. of the total nutrients. However, of the coarser feeds — such as hay and straw — he can recover only from 40 to 50 per cent., the remainder being discarded without benefit to the animal, much as the cinders, ashes, and unburned gases pass out of the steam engine without being converted into heat.

The food which is taken into the body of the animal is first chewed fine and softened by mixing with from one to four times its weight in saliva, to prepare it for the digestive juices of the stomach. These juices, aided by ferments in the saliva and in the food itself, start the work of reducing the nutrients in the food to the soluble form in which they are taken into circulation. The horse's stomach has a capacity of but twelve to fifteen quarts, hence must be emptied several times during a meal. The liver and the intestines, therefore, perform a large part of the work of digestion. This process of assimilation plays no small part in the total work of the animal body. A horse's jaws, moving eighty times per minute, will require from two and one half to three hours to chew the hay ration. From five to six hours for oats and six to eight hours for hay are required for the digestive organs to complete their work. Frequently, as is the case of straw, the energy required to chew and digest the food is greater than the energy recovered from it.

The various foodstuffs are composed of classes of compounds known as proteids, fats, carbo-hydrates, ash and water. The ash contains a small amount of mineral matter required in the bony framework of the body, and the water is necessary for the free action of the various bodily functions. Otherwise,

these two classes have little energy value. Of the other three classes, the fats are usually unimportant in feeds for horses, being present in relatively small amounts. They are, however, rich in heat-producing value, being about two and one quarter times as valuable in this respect as the proteids or carbohydrates. The fats consist of true vegetable fats and oils, such as cottonseed and corn oil, waxes, and various coloring matters in plants.

The muscular tissue of the body is largely composed of proteids or nitrogen-bearing compounds. A certain amount of these compounds must, of course, be present in the feed, in order to maintain the body at its normal state. In the absence of fats or carbo-hydrates, the proteids may be used for energy. However, since they are usually much more expensive than the carbo-hydrates, the most economical rations contain only sufficient amounts of various proteids to maintain the body. The bulk of the energy supplied to the work horse should come from the carbo-hydrates. This class includes the various sugars and starches, also the crude fiber or cellulose which give strength to the structure of the plant.

The crude fiber is less digestible than the sugars and starches, but is equal to them in total heat value. Thus the animal, in a sense, is less efficient than a steam engine, which can make use of the entire plant, as, for instance, when straw is burned underneath a steam boiler. The horse at hard work has less opportunity properly to chew and digest the rough, coarse hay and fodder supplied, consequently wastes a much larger proportion than when at rest. On this account it is probable that the average farm horse receives much larger amounts of hay than he can economically use. Even at rest the horse is much less efficient than cattle or sheep in making use of the coarse material, such as hay and straw. The latter animals have greater capacity in the alimentary canal, consequently retain the food from 50 to 100 per cent. longer than the horse. This allows extensive fermentation to occur, consequently

utilizing a larger proportion of the total heat value of the food. In comparing the horse and the mechanical motor, we encounter different standards of estimating efficiency. The engineer compares the *total heat units* in fuel supplied with the equivalent of heat units delivered by the motor as useful work, calling the ratio *thermal efficiency*. The physiologist determines a *fuel value* for a given feed by ascertaining the percentage of *digestible nutrients*, and on this basis, or one even more favorable, the animal's efficiency is frequently calculated.

Of the fuel value, or digestible nutrients of the food, about 30 per cent. is lost in the energy required to chew and digest the food; consequently there is a further value of the food, which is termed by students the *maintenance value*. This is the proportion of the food which can be utilized by the horse in maintaining his body weight while performing no work, and from this value can be calculated the ration which must be fed an animal in order to sustain it at a given weight during idleness. If less digestible food is supplied to the animal during such idle period than is necessary for its maintenance, the animal may draw on its store of muscular tissue or fat and continue to live at the expense of weight.

If work is required of the animal in addition to keeping the body at its normal size and condition, an excess of digestible food must be supplied, and experiments go to show that only about one third of this excess is actually recovered in the shape of external motion. This leaves, then, a value for the food which is known as the *production value*. In other words, out of the total heat value of the original food, we have now a value representing the amount of external work that can be recovered from a given amount of feed. But even of the external work performed by the horse, a certain amount is used in moving his own body forward, since he is able to deliver work only when moving, and under the best conditions his efficiency is low. Instead of a thermal efficiency (or ratio of work delivered to food consumed) of 35 to 40 per cent., that has been proclaimed by

various writers, including authorities of the United States Department of Agriculture, the real thermal efficiency of an average horse, even at heavy, continuous work, is probably not more than 6 to 10 per cent. Many internal combustion tractors have done as well as this in draft tests, and some much better.

Under laboratory conditions, with scientifically fed animals doing maximum work, a thermodynamic efficiency of 20 per cent. has been obtained, that is, one pound of food has been turned into work for every four wasted. Farm conditions, however, and even teaming conditions in cities, are vastly different from those of the laboratory.

## V

### THE EFFICIENCY OF THE HORSE

**T**HE classic experiments of James Watt placed the working power of a 1500-pound cart horse at the ability to lift 33,000 pounds to a height of one foot each minute, whence came the term "horsepower."

More recent experiments, however, indicate that the energy delivered by the average horse is nearer 22,000 foot-pounds per minute, or two thirds horsepower. General Morin, a French investigator, puts the horse's capacity at .79 h.p. Trautwine puts the net useful work of the average horse working in a circular sweep at 10,000,000 foot-pounds per day of eight hours. Assuming 85 per cent. mechanical efficiency for the sweep, this would be equivalent to practically  $\frac{3}{4}$  h.p. Langworthy, in Bulletin 125, Office of Experiment Stations, puts the total daily work of the average horse at 10,560,000 foot-pounds. Conclusions of experimenters vary considerably, doubtless because they have worked under different conditions with horses of different size and individual merit.

Numerous authorities unite in putting the working draft or pulling power of a horse at one tenth his weight when working at the rate of two and one half miles per hour continuously for ten hours per day. Under these circumstances a 1200-pound horse will develop .8 h.p., and a 1500-pound horse 1 h.p. Trautwine and King both state that if the hours of work be shortened toward a limit of five hours per day, the draft of the horse may be increased accordingly. They state also that between the speeds of three fourths of a mile and four miles per hour the working draft of the horse will be

increased or decreased in inverse proportion to the rate of travel. The maximum draft of a horse at any time is about one half his weight, and can be exerted only for a short time without injury; however, there are numerous instances to show that for an instant a horse may actually exert a momentary pull more than equal to his weight.

The proprietor of a very systematically managed ranch of 25,000 acres, in Kansas, with records covering the work of large numbers of mules for thirteen years, puts the net furrow travel of a plow team, spending nine hours per day in the field, at from 1.5 to 1.75 miles per hour, depending upon the severity of the work. In other words, the plow will actually turn a furrow 1.5 to 1.75 miles long in an hour, after deducting for all stops, turns, etc. Assuming Trautwine and King to be correct as to the possible increase in draft during a shorter day, a 1000-pound mule on this ranch should be able to overcome a continuous resistance of  $1000 \div 10 \times 10 \div 9 \times 2.5 \div 1.75 = 159$  pounds. This accords closely with what may be concluded from a knowledge of the draft of plows. We may, therefore, assume Sanborn to be correct in his statement that 150 pounds may be regarded as the pulling power of the average plow horse.

According to the investigations in Minnesota, the farm horse works from five to six and one half hours per day, as an average for the most active season. During this short day, he will be able to exert much more pull than his normal capacity. Investigations in the Central states by one of the writers showed that the work animals on farms visited, averaged about 1300 pounds, but more than usual use was made of machinery and animal power. Placing the average farm horse in the West at 1200 pounds in weight, it is probable that for the short day he works at the plow, he is capable of developing under pressure one horsepower, which is equal to a draft of 187.5 pounds at the rate of two miles per hour.

The Bureau of Statistics, United States Department of Agriculture, has for about nine years conducted careful investiga-

tions as to the cost of producing farm products on a group of farms at Halstad, Minn., in the Red River Valley. Small grains are the principal crop on these farms, which average 379 acres in size, and conditions are quite similar to those where traction engines are more extensively used. The results of six years of investigation are published in Bulletin 73 of the above bureau.

From data given therein we find that during the eight months from April to November, inclusive, 135 horses worked an average of 4.33 hours per week day, or a total of 906 hours. For 104 working days, during the four inactive months, the average was .77 hour per day. It is quite possible that these horses, which averaged about 1200 pounds in weight, exerted a full horsepower during every hour of work in the plowing season. On the other hand, during other seasons there was much time while the horses were in harness that they were exerting very little or no power, since the hours reported included the entire time they were in the field.

As a yearly average, from 1905 to 1907, each horse at Halstad consumed 3.64 pounds of grain, and 6.55 pounds of hay for each hour of work. The grain ration was made up largely of corn, oats and barley, and the hay ration of timothy, wild grasses, mixed hays, etc. Some pasturage and straw were received in addition to the foregoing ration.

According to Prof. H. P. Armsby, of Pennsylvania State College, who is recognized as the foremost authority on animal nutrition in America, the total heat values per pound of common feeding stuffs are as follows, the value in B.t.u. being computed by the writer from the value in calories:

## TOTAL HEAT VALUE OF FEEDSTUFFS

	<i>Calories</i>	<i>B. t. u.</i>
Timothy hay . . . . .	2045	8119
Oat straw . . . . .	2012	7988
Clover hay . . . . .	2025	8039
Corn meal . . . . .	2010	7980
Oats . . . . .	2125	8436
Wheat bran . . . . .	2065	8198
Linseed meal . . . . .	2314	9187



Feeds containing much fat or protein, or both, tend to run higher than the average, but ordinarily the total heat value does not vary widely as between the different feeding stuffs. If we assume the ration at Halstad to have been composed of mixed timothy and clover hay, and equal parts of corn and oats, a total of 82,795 B.t.u. was supplied for each hour of work. This corresponds to a thermal efficiency of 3.07 per cent., on the basis of an average of .8 h.p. for the year. Langworthy, Rose, Chase, and others place the working power of the average horse at  $\frac{2}{3}$  h.p. during the time at work, which would reduce the efficiency to about 2 per cent. in pulling. For stationary work through a tread mill, or circular sweep, it would be at least one tenth less, due to the loss of efficiency in transmission. If the many hours of light work and the heat units provided in straw and pastured grass were also taken into consideration, it might safely be said that under the given conditions the average farm horse returns in work only from 1 to  $1\frac{1}{2}$  per cent. of the energy supplied in foodstuffs.

Contrary to popular opinion, the horse is even less efficient under conditions of diversified farming. On a group of smaller farms studied in the same manner, at Northfield, in southwestern Minnesota, more diversification of crops and live stock is found. Yet at Northfield each hour of work required 7.46 lbs. of hay and 5.5 lbs. of grain. From various sources it has been determined that the horse requires at least 2 lbs. of water at rest, and at least  $3\frac{1}{2}$  lbs. at work, for each lb. of dry matter, or from 70 to 100 lbs. per day, according to the weight of the animal, the ration, and the amount of work.

The great tax put upon the farmer by the necessity for maintaining horses throughout the winter months is shown by the fact that at Halstad, in addition to its care, the average horse received 9.8 lbs. of hay, 9.2 lbs. of grain, and an unrecorded amount of straw for each hour of work from November to March inclusive. Roughly, this would furnish 155,000

B.t.u. for hay and grain alone. The winter work being usually of very light nature, it is probable that out of 100 pounds of energy fed, less than one pound is recovered as work. Obviously, these figures can be regarded as only approximate, since no tests have been made of the efficiency of the animal under the above conditions. They furnish, however, striking exceptions to the general idea as to the efficiency of the animal as a machine.

If the energy which passes unchanged through the animal body; the energy required to chew and digest food; the energy required to maintain vital processes and body heat; the energy required for moving the animal body — if all this be subtracted from the original heat value of the food, and only the energy liberated in the animal muscle during work be taken as a basis, an efficiency of 25 to 40 per cent. may be computed. This has been the foundation for the statement that the animal is a much more efficient machine, viewed solely from the standpoint of transforming fuel into energy, than any made by man. This is not always the case. Under farm conditions, where animals are worked only a few hours per day, on the average; where feeding is usually unscientific and wasteful; and where, according to T. H. Brigg, an English scientist, the horse often labors under conditions where 50 per cent. of his energy is lost, the horse becomes a very inefficient motor, at least as regards the conversion of chemical energy into useful work.

Neither animals nor engines are worked to their full capacity on the ordinary farm, but there is this difference: the fuel consumption of the engine is measured by the amount of work done, plus only the energy required to overcome friction within the engine itself during the time at work, with nothing for maintenance during long periods of idleness. Speaking of the horse at rest, Professor Armsby says: "The case is like that of an engine run with no load, which still requires a certain amount of fuel to keep it running." Only rarely does

the farmer understand and meet the food needs of the horse as accurately as the engineer meets the fuel needs of his engine.

The thermal efficiency of a motor is, however, not a true test of its value to the farmer. The economy or commercial efficiency is of more practical moment. From the investigations at Halstad, Minn., we find the average farm value of food alone to be 4.3 cents for each hour of horse labor throughout the year. On the basis of 4.5 h.p. developed, the cost of fuel per horsepower-hour is 5.4 cents, and at  $\frac{2}{3}$  h.p., 6.5 cents. During the motor contests held in Canada in 1909 the cost of fuel per actual horsepower-hour was  $1\frac{1}{2}$  cents for steam, and 2 cents for gasoline engines, at stationary work, and approximately double these figures in plowing. The higher fuel cost in Canada would tend to effect the difference between farm and contest efficiency.

The data just quoted for the cost of horse feed were averages of the period from 1905 to 1907. In 1910, according to the *United States Crop Reporter*, the price of grain is about 25 per cent. above the average of those three years, and that of hay approximately equal. The costs shown for fuel were taken at Winnipeg, in July, 1909, and would be no higher at present prices. In Montana, grain is about 50 per cent., and hay 100 per cent., higher than in Minnesota, while the cost of liquid fuel is also considerably advanced. Varying character and prices of both fuel and food affect the relative commercial efficiency of animal and mechanical motors in different sections, but in general farm practice the horse is less economical in the production of work from latent energy than the tractor, on either the technical or commercial basis.

## VI

### ESSENTIALS OF THE DRAFT HORSE

**W**ITH the necessity for greater power, horse buyers have placed a premium on weight in advance of all other considerations. During the panic of 1893, when the average price of horses was falling nearly 100 per cent., the sales by a leading firm of horse dealers in Chicago showed unmistakably the value of powerful animals. From 11.1 cents per pound for horses weighing 1400 pounds, the average price per pound on all horses sold that year constantly increased with added weight to 14.4 cents per pound for 1800-pound animals. While many of these horses were bought for the city trade, the figures signify an awakening to the value of larger power units.

The essentials of a heavy draft horse, such as will most economically develop power for plowing, are best set forth in some of the score cards in use at the leading agricultural colleges. In the one given herewith, weight, action, and the conformation of soundness of feet and legs are given their proper emphasis:

#### DRAFT HORSE SCORE CARD

CLASS, GELDING

*General Characters*

Form — Broad, massive, blocky, low-down, compact, and symmetrical. Scale large for the age.

Quality — General refinement of clean-cut and symmetrical features; bone clean, large, and strong; skin and hair fine, tendons clean, sharply defined, and prominent.

Constitution — Generous and symmetrical development; lively carriage; ample heart girth, capacity of barrel and depth of flanks; eyes full, bright and clear; nostrils large and flexible; absence of grossness or undue refinement.

SCALE OF POINTS	PERFECT SCORE
1. Height, estimated . . . . hands; corrected . . . . hands	
2. Weight, estimated . . . . lbs. corrected . . . . lbs.;	
score according to age and condition . . . . .	10
3. Action, walk: rapid, springy, regular, straight; trot: free,	
balanced, straight . . . . .	15
4. Temperament, energetic, tractable . . . . .	3
5. Head, proper, proportionate size; well carried; profile straight	1
6. Muzzle, neat; nostrils large, flexible; lips thin, even, firm	1
7. Eyes, bright, clear, full, both the same color . . . . .	1
8. Forehead, broad, full . . . . .	1
9. Ears, medium sized, well carried . . . . .	1
10. Lower jaw, angles wide, well muscled . . . . .	1
11. Neck, well muscled, arched; throat-latch fine; windpipe large	2
12. Shoulder, moderately sloping, smooth, snug, extending into	
the back . . . . .	3
13. Arm, short, strongly muscled, thrown back . . . . .	1
14. Forearm, long, wide, clean, heavily muscled . . . . .	2
15. Knees, straight, wide, deep, strong, clean . . . . .	2
16. Fore cannons, short, wide, clean; tendons clean, well defined,	
prominent . . . . .	2
17. Fetlocks, wide, straight, strong, clean . . . . .	1
18. Pasterns, moderately sloping, strong, clean . . . . .	3
19. Forefeet, large, even size; sound; horn dense, waxy, soles	
concave; bars strong, full; frogs large, elastic; heels wide,	
one half length of toe, vertical to ground . . . . .	8
20. Chest, deep, wide; breastbone low; girth large . . . . .	2
21. Ribs, deep, well sprung; closely ribbed to hip . . . . .	2
22. Back, broad, short, strong, muscular . . . . .	2
23. Loins, short, wide, thickly muscled . . . . .	2
24. Barrel, deep, flanks full . . . . .	2
25. Hips, broad, smooth, level, well muscled . . . . .	2
26. Croup, wide, heavily muscled, not too drooping . . . . .	2
27. Thighs, deep, broad, muscular . . . . .	3
28. Quarters, plump with muscle deep . . . . .	2
29. Stifles, large, strong, muscular, clean . . . . .	2
30. Gaskins, long, wide, clean, heavily muscled . . . . .	2
31. Hocks, large, strong, wide, deep, clean, well set . . . . .	8
32. Hind cannons, short, wide, clean; tendons clean, well	
defined . . . . .	2
33. Fetlocks, wide, straight, strong, clean . . . . .	1
34. Pasterns, moderately sloping, strong, clean . . . . .	2
35. Hind feet, large, even size; sound; horn dense, waxy; soles	
concave; bars strong, full; frogs large, elastic; heels wide,	
one half length of toe, vertical to ground . . . . .	6
<b>Total . . . . .</b>	<b>100</b>

Youatt in his "Treatise on the Horse" quotes an old English description which embodies most of the foregoing points in more imaginative style:

"A good horse should have three qualities of a woman — a broad breast, round hips, and a long mane; three of a lion — countenance, courage, and fire; three of a bullock — the eye, the nostril, and joints; three of a sheep — the nose, gentleness, and patience; three of a mule — strength, constancy, and foot; three of a deer — head, legs, and short hair; three of a wolf — throat, neck, and hearing; three of a fox — ear, tail, and trot; three of a serpent — memory, sight, and turning; and three of a hare or cat — running, walking, and suppleness."

## VII

# THE STEAM TRACTOR AS A MOTOR FOR PLOWING

### HISTORY

**T**HE early history of attempts to apply the power of steam to the world's great work of transportation is of intense interest. The idea of the traction engine goes back to James Watt, the discoverer of steam. As early as 1759, his attention was called to the possibility of building a carriage to be driven by steam. His partner, Mathew Boulton, was later urged to construct such a "fiery chariot," but the first self-moving steam carriage was apparently built by a French army officer, named Cugnot, whose second engine, built in 1770, is still preserved in Paris. Sixteen years later an American, Oliver Evans, asked the Pennsylvania Legislature for a monopoly on his method of applying steam to the propelling of wagons. From this time on, until Stephenson's railway locomotive of 1825, inventors of steam carriages were numerous in both Europe and America. However, the prevailing idea up to the time of Stephenson's invention and even later was the development of steam carriages for the transportation of passengers and freight over ordinary roads.

The first recorded steam plowing engine in the United States was that of J. W. Fawkes, who built in 1858 a plowing "drag," which he operated in Pennsylvania. A two-cylinder engine, with 9- by 15-inch cylinders, was geared to a drum six feet

wide, which took the place of the drive-wheels. Steam was supplied by an upright tubular boiler, with 300 feet of heating surface. The driving drum was bulged in the middle like a barrel to permit of easy turning, the modern compensating gear not having been invented. This engine drew eight plows at the rate of three miles per hour over original prairie sod, hence steam plowing on a large scale is by no means a modern idea. Several other men in Connecticut, New York, and New Jersey were at the same time busy on traction engines for plowing. In 1871 the Royal Agricultural Society of England held trials extending over several months, in which the adaptability of all plowing and cultivating engines up to that time were thoroughly tested. Steam had been applied to the plow through cables by John Fowler & Sons, of Leeds, in much the same manner as their outfits are built to-day, and their tackle won high honors. In the meantime, the steam carriage as a factor in road transportation seems to have been lost sight of, largely because of rough roads, hostile public opinion, and the rapid development of steam railways.

A device for allowing the drive-wheels to travel at different speeds is mentioned in the early 30's, but the differential gear which has made the modern power vehicle so adaptable was not perfected until about 1870, when Prof. R. H. Thurston described it as "new and very neat." The friction clutch soon followed, still further adding to the easy manipulation of the tractor. From 1875 to the close of the century, development in American steam tractors was very rapid. Their utilization in plowing began almost as soon as they became self-propelling. Their serious use for this purpose, however, is not recorded until in the years just preceding 1890, when scattered operators began to use the most powerful threshing engines of that day for plowing, with only moderate success. The steam engine is a century and a half old, but



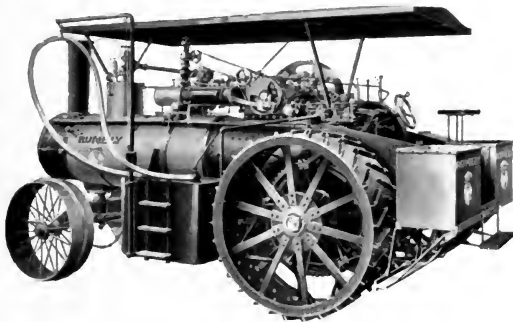

STEAM TRACTORS  
Transmission gear  
Complete steam plowing engine



the steam plowing engine of to-day is a creation of the twentieth century.

#### ESSENTIALS OF THE TRACTOR

The steam tractor consists essentially of a boiler, engine, traction gearing, and wheels, with all the necessary fittings for carrying fuel and water, supplying these to the fire box and boiler, respectively, controlling lubricating the engine, and steering. Steam is generated in a boiler by the heat produced in the fire box and admitted to a closed cylinder, where it moves a piston. The piston rod drives a connecting rod which in turn causes a crankshaft to revolve. The power thus produced is transmitted by a belt to a machine requiring rotary motion to operate it, or is transformed into linear pull by a train of gears and the wheels which grip the ground. In discussing the steam engine, only those principles and devices employed on the leading plowing tractors will be included. This eliminates much that might be said of stationary engines and of many traction engines which have been designed primarily for threshing and only partially adapted to the severe work of plowing. Some topics common to both types of tractor are discussed more fully in the chapters devoted to the gas tractor.

#### GENERATOR OF POWER

Steam is generated in a boiler to which heat is applied on one side of a metal surface, on the other side of which is water. The expansion of water decreases its density and colder water displaces it. The resulting circulation gives the entire mass a uniform temperature. On reaching a certain temperature, determined by the pressure upon the surface, the water boils and steam is formed. This takes place at  $212^{\circ}$  F. under the ordinary atmospheric pressure of 14.7 pounds per square inch. At higher altitudes the boiling point will be reached

earlier, and in a steam boiler under considerable pressure, the boiling point will be higher. We have seen that it requires one B.t.u. to raise the temperature of one pound of water one degree F. However, to overcome the cohesion of the water particles and turn one pound of water into steam, requires the application of approximately 967 B.t.u. In evaporating water under pressure, not only this internal resistance, or latent heat, of the water itself must be overcome, but also the outside pressure upon it. With 100 pounds of pressure it requires a temperature of  $337^{\circ}$  F. to convert water into steam.

During the evaporation of water into steam, the temperature of the steam will not rise above that of the water, but if heat be applied to the steam away from the water, it will rise in temperature and become a superheated, invisible gas. So long as it remains in contact with water, steam will carry some water in suspension, hence to produce absolutely dry steam, without superheating, is next to impossible under the conditions surrounding the ordinary boiler. The amount thus carried is seldom less than 2 per cent., but anything over 3 per cent. is regarded as objectionable.

#### COMBUSTION

Fuels used in the steam engine contain a high percentage of carbon, varying with the material, and amounts of hydrogen, sulphur, nitrogen, oxygen, moisture, and the mineral elements which make up the ash. Air is a fairly constant mixture, composed of about four parts of nitrogen, one of oxygen, and traces of carbonic acid gas, (or carbon dioxide), water, nitric acid and ammonia. At a given temperature, depending on a number of factors, the free oxygen of the air will unite with the free carbon and other combustible elements to form the gases of combustion. Heat is thrown off as the union takes place, and the more perfect the combustion, the greater the heat produced. In an insufficient supply of air, for instance, a pound of carbon burns to carbon monoxide (CO) instead of



**ENGINE POWER FROM CULTIVATING TO THRESHING**

**A 40 horse-power tractor and its load in California**

**The engine that plowed the field hauling the harvesters**

**A steam tractor furnishing power for a threshing machine**



to carbon dioxide ( $\text{CO}^2$ ), and produces only 4480 B.t.u. instead of the 14,647 which should be secured. The hydrogen burns to form water ( $\text{H}^2\text{O}$ ), giving off 62,100 B.t.u. per pound. The sulphur forms sulphur dioxide ( $\text{SO}^2$ ), which in the presence of water, finally becomes sulphuric acid and accounts for the corroding effect of coal smoke on steel, for example, on wire fences along railways.

#### THE TRACTION ENGINE BOILER

##### *Types of Boiler*

Three classes of boiler are used on steam tractors — namely, the locomotive or direct flue, the return flue, and the vertical. In the first, which is practically universal on plowing engines, the gases pass from a fire box at the rear to the smoke box in front through tubes, or flues, two or three inches in diameter,

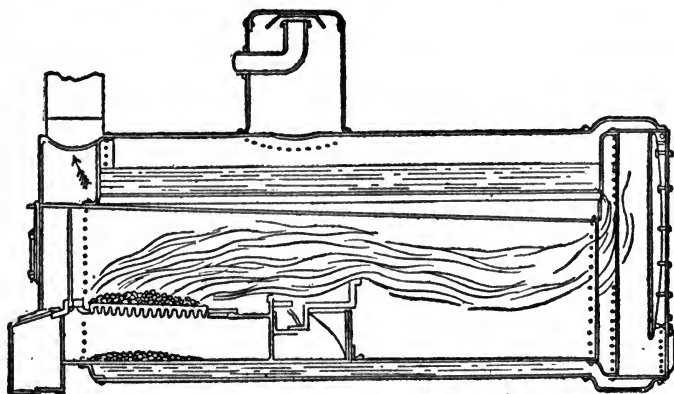

Return flue boiler

and thence to the stack. The boiler proper is separated from the fire box and smoke box by a boiler head or tube sheet, which is perforated to support the tubes. The fire box is practically a part of the boiler itself, being built into the boiler shell and

partially or wholly surrounded by a water space connected with that of the boiler. In the vertical boiler the upright tubes are surrounded by water to a part of their height, the gases passing directly upward. This is not an economical type and is little used. The greatest fuel economy is secured by the return flue boiler, which takes the gases from the fire box to the front of the boiler and returns them through smaller flues to the rear. This type is less convenient to handle or repair than the locomotive type, and cannot so easily be adapted to the use of wood or straw.

### *Boiler Construction*

Stringent laws in some states and provinces now practically force the use on plowing tractors of a boiler shell composed of a cylindrical sheet with a single longitudinal seam. The seam may be lapped or the edges of the plate may be brought together and double riveted to reinforcing steel straps inside and out. Steel bolts and cap screws may be and sometimes are used, provided a reinforcing plate is riveted on the boiler. In most late types practically no bolts are used, either in the construction of the boiler or the mounting of the engine and shafting upon it. Steel wing sheets are riveted to the boiler for the support of these features, in place of the cast iron which was formerly used for brackets and various other parts not exposed to sudden change in temperature. The boiler on a modern plowing engine can safely be run at 200 pounds pressure, though 175 pounds is usually set by law as the maximum. The extreme severity of the work to which the traction engine is subjected, and the neglect which it suffers, are nowhere more emphasized than in the extraordinary precautions which engine manufacturers are required to take in constructing their boilers.

Ordinary coal-burning locomotive boilers may be adapted for burning wood, corncobs, straw, etc. The wood-burning boiler requires simply larger grate openings, if any change is



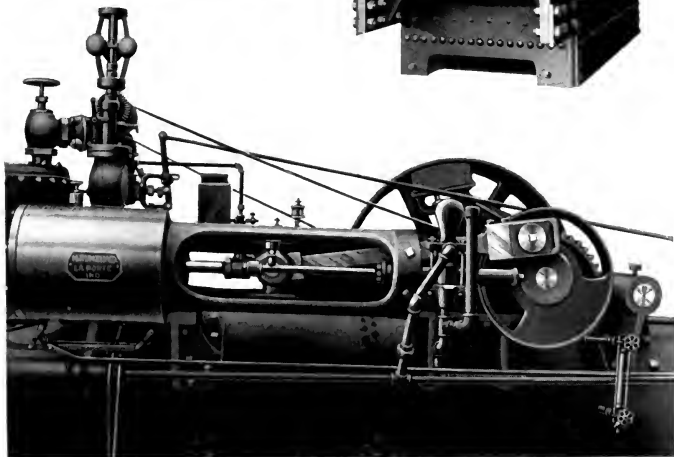
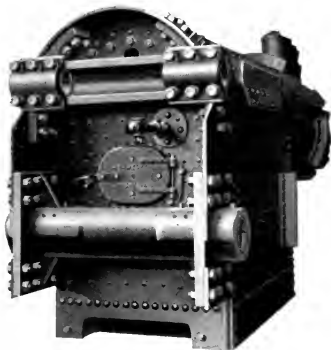
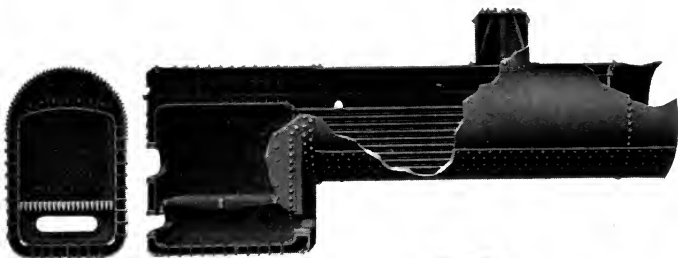

**DETAILS OF STEAM TRACTOR**

Sectional view of locomotive boiler

Cleaning the boiler

Rear mounted construction

Single cylinder engine



made. The straw-burning attachment consists of a rather long feeding chute with a trap door, a dead plate upon which the straw drops, short grates, and a brick arch which deflects the draft toward the incoming straw. The draft is considerably reduced, all the straw is consumed in the fire box, and the gases are fully heated before entering the flues.

The boiler jacket, which may be composed of wood, asbestos, air spaces, or other non-conducting media, encased in a galvanized steel covering, renders the boiler from 6 to 10 per cent. more efficient. Considering the exposed nature of the work, every plowing engine should be thus protected.

The crown sheet — *i.e.*, the top of the fire box — is arched in the best plowing engines in order to resist the pressure of the water and steam above it. The bottom of the fire box is either open or closed. If closed, the fire box is usually surrounded entirely by water. This gives additional heating surface and better circulation, provided the space at the bottom is kept free of sediment. In the open-bottom fire box the water legs, which extend down on all sides, are closed at the bottom. This allows the grates to be set lower, and the combustion chamber thus enlarged. It also allows easy removal of the ash pan and grates, for cleaning or relining the fire box. The draft may be admitted from either front or rear without reducing the heating surface. The fire box walls proper are held in place by tight-fitting threaded stay bolts, screwed through the plates of the boiler shell and the fire box. A set of rocker grates is usually installed, so that the fire may be kept clean without poking from the top, which invariably causes a loss of heat in unburned carbon.

Owing to the small grate area which can be profitably provided in a traction engine, it is necessary to have some means of increasing the draft. Engines are usually provided with a blower through which live steam can be passed into the smoke stack, a vacuum being created by its velocity and condensation. This method is used in getting up steam, the blower being

turned on when sufficient steam pressure to operate it has been secured by ordinary draft. When the engine is running, the exhaust steam is usually turned into the stack through an exhaust nozzle. The intensity of the draft created by this means can, of course, be controlled.

The water space in a boiler extends around the fire box and to some distance above the highest flues. Above this is the steam space, including a bell-shaped projection known as a steam dome, into which the driest steam rises. From the top of the steam dome extends the pipe for taking steam to the cylinder, this usually being protected by a wire gauze strainer in order to minimize the percentage of water carried over into the cylinder with the steam.

### *The Water Supply*

For supplying water to the engine the plowing outfit necessarily includes one or more portable tanks, which are usually made of steel with riveted seams. They have a capacity of from ten to sixteen barrels and are provided with a hand pump for filling and emptying. A box on top affords space for carrying a considerable quantity of coal or odds and ends. On the engine, in addition to the water contained in the boiler, there must be tank capacity sufficient for at least an hour's run. Engines therefore carry from one to three tanks with a capacity of from fifteen to twenty barrels. These are usually placed to secure the most advantageous distribution of weight upon the drivers. It is now possible, by the aid of a hose-crane and steam jet, to economize labor and time by filling the engine supply tanks from the wagon tank without stopping the outfit.

The traction engine boiler is supplied with water from the supply tanks either by a pump or an injector, and sometimes both. The pump may be attached to the cross-head of the engine, in which case it can operate only when the engine is running. A more convenient type is an independent steam

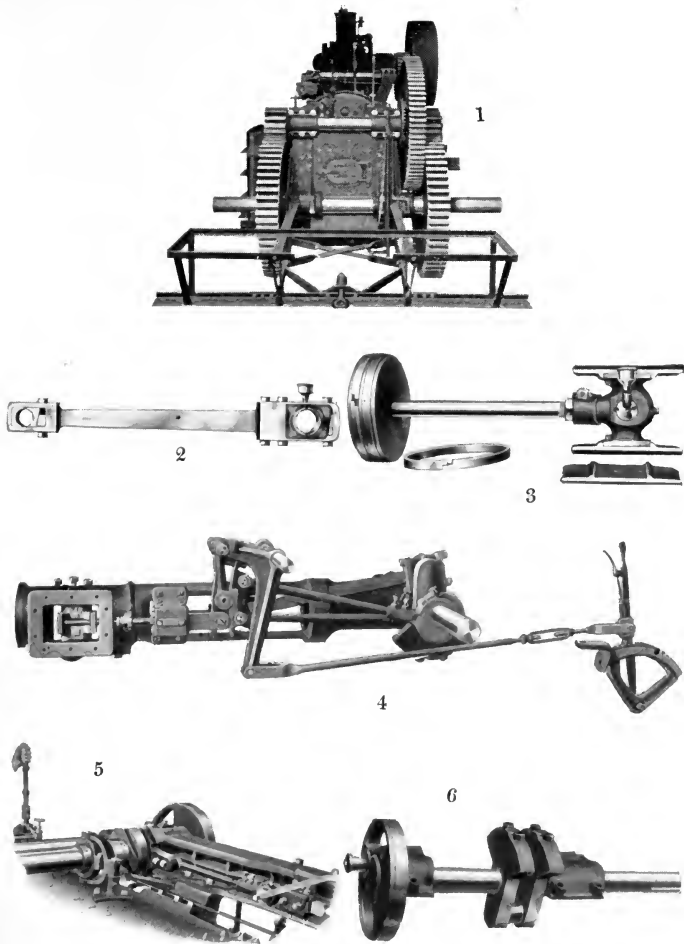

**DETAILS OF THE STEAM TRACTOR**

1. Transmission gear
2. Connecting rod
3. Piston and cross-head
4. Double eccentric reverse gear
5. Single eccentric reverse gear
6. Crankshaft of two cylinder engine



pump, which is really a small steam engine working a plunger which is connected directly to the piston rod of the pump. The injector draws steam from the upper part of the boiler and feeds cold water into the lower part by the combined effect of the velocity and condensation of the steam. The injector is simple and satisfactory, provided it is properly chosen with reference to the conditions of its work.

In order to protect the boiler from sudden changes in temperature due to the incoming of cold water, the latter is usually passed through a heater located between the pump and the boiler. The pipes are usually surrounded by the exhaust steam, though occasionally live steam is introduced directly into the water to raise its temperature.

#### *Safety Devices*

To prevent the water from being carried too high or too low, a glass water gauge and several try-cocks are connected to the boiler near the level of the crown sheet. A steam gauge is also provided for indicating the boiler pressure. The essential feature of the steam gauge is a metal tube bent in semi-circular form. One end is attached to the boiler by a siphon, which keeps air in the tube and protects it from the heat of the live steam by a cylinder of water. The pressure of the steam upon the outside circumference of the tube tends to straighten it as water straightens a hose. The pressure is indicated upon a dial by means of a suitable link and needle.

The steam engine boiler must be equipped with a safety valve for releasing the pressure when it rises to a certain point. Plowing engines usually have what is known as a spring or lock pop valve in which the valve is kept in position by a powerful spring which may be adjusted for action at different pressures.

A soft metal plug, usually of Banca tin, which fuses at a lower temperature than iron or brass, is placed in the top of the crown sheet. Should the water become low, the plug will melt and the steam, pouring through, will put out the fire.

Otherwise the sudden conversion into steam of the thin layer of water above the crown sheet might result in an explosion. The crown sheet must be kept covered under all circumstances. The difficulty of doing this on a descending grade has led to the adoption of special devices in some boilers to maintain water at a higher level over the crown sheet at such times than in the rest of the boiler.

The boiler requires frequent cleaning unless very pure, soft water is used. This is especially true in the alkali districts of the West, where boilers become incrustated with a heavy scale in a week's time. This scale prevents the rapid conduction of heat to the water. It also increases the danger of overheating the metal, and it is thought that boiler explosions are frequently caused when a large mass of scale drops away from some overheated part, and a large quantity of steam is suddenly produced. Convenient hand holes are placed at various points around the boiler and fire box, especially in the lower portion of the water legs, as the sediment naturally drops to the lowest points. In order to facilitate frequent cleaning of the water legs, blow-off cocks are placed so that the sediment may be blown out by steam. A large door on the front end of the smoke box enables the operator to get at the flues for cleaning them of soot and cinders. A spark arrester in the top of the stack, or else a sharp angle in the smoke box through which the smoke must pass, will collect the cinders. Some such provision is necessary for safety to surrounding objects.

### *Boiler Power*

Boilers are rated as to horse power according to the amount of water which they will evaporate. The standard of the American Society of Mechanical Engineers requires the evaporation on one hour of thirty pounds of water from 100° F. under a pressure of seventy pounds, which is considered equivalent to evaporating thirty-four and one half from and





## TRACTOR MISHAPS

A wreck in Missouri  
A broken bridge in Oregon



at 212° F. The amount thus evaporated, compared with the heat units supplied in the fuel, determines the boiler efficiency. Another method of rating is by the area of heating surface. The heating surface includes all parts exposed to heat on one side and water on the other. It includes the crown sheet, the insides of all flues, the water legs, and the part of the tube sheet exposed to heat. It is customary to allow one horsepower for from 11.5 to 14 square feet of heating surface. This, however, gives a rating too low for the majority of traction engine boilers, on account of the forced draft commonly employed.

#### THE TRACTOR ENGINE

##### *Types of Engines*

The majority of engines are of the simple, non-condensing type. In other words, the steam is expanded but once, and the exhaust steam is not condensed so as to retain its heat. They are not economical, therefore, as compared with those found in large stationary plants. In the compound engine the steam is usually superheated by passing it back through pipes in the steam space and fire box. It is admitted first to a small cylinder and again expanded in a larger one. Both cylinders work through a shorter range of temperature; less radiating surface is exposed to the high pressure steam, and much less material is required to make the small cylinder sufficiently strong for safety. There are very few compound engines on plowing tractors, though both tandem and cross-compound engines are used with good results. In the former the high and low pressure cylinders are placed end to end, while in the latter they are side by side. Some cross-compound engines may be converted at will into double simple engines for starting a heavy load or moving it at a slow speed.

The larger and more powerful simple engines are usually equipped with two cylinders for plowing purposes. For

light work, the double engine is hardly necessary. Prof. L. W. Chase says, in "Farm Machinery and Farm Motors": "Although a double engine is more easily handled than a single one, there are only a few instances, such as plowing and heavy traction work, where its use is recommended for farm work." The single cylinder engine is the more economical of fuel and has fewer parts to get out of order. The double engine with cranks  $90^\circ$  apart can never be stopped on dead centre so as to require turning over by hand. (An engine is said to be on dead centre when a straight line will pass through the centres of the cross-head, the crankpin, and the crankshaft, so the thrust of the piston operates directly against solid metal instead of turning the shaft.) At least one crank is always in position to be acted upon by the connecting rod, and the two cylinders working together are able to start a heavy load easily and without damage to any part. The division of work between two cylinders naturally gives better balance and greater durability.

As compared with the two-cylinder gas engine the double-cylinder steam engine gives four impulses to the crankshaft at every revolution of the flywheel, where the gas engine gives but one. On this account the crankshaft is not exposed to the same shock and vibration, hence is made much smaller.

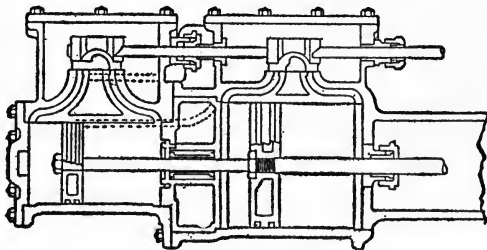

Tandem compound steam engine

By way of illustration it may be said that the crankshaft on a well designed two-cylinder gas tractor developing 70 b.h.p.

is four and one half inches in diameter, as compared with three and one half inches on a steam tractor developing 140 b.h.p. A cross-section of the two shows the gas engine shaft to be nearly two thirds larger than the corresponding part on a steam engine of the same number of cylinders and double the power.

### *The Governor*

One of the most vital points of the engine is the governor, which may be likened to the human heart in its importance and action, regulating as it does the energy delivered in accordance with the need. The farm tractor never enjoys absolutely uniform working conditions. In fact, in plowing the variation in soil in single field, to say nothing of grades and other obstructions, creates enormous differences in the power required. In order to prevent the outfit from stalling on the one hand, or from running at an abnormal and dangerous speed on the other, a sensitive governor must be employed.

The speed regulation is effected by means of a flywheel attached to the crankshaft, and a governor, usually of the throttling type, which regulates the admission of steam according to the needs of the load. The governor consists of two or more weights which are free to swing outward by centrifugal force, and in doing so pull down upon a spindle which operates the throttle valve, controlling the opening in the steam admission pipe. The governor may be set to maintain various speeds. If the governor permits considerable fluctuation of speed under a constant load, it is either of poor design, poorly lubricated, or driven by a slipping belt.

### *Valves*

The steam passes through the throttle valve to the steam chest and thence through a valve to the cylinder. The ordinary type of valve on traction engines used in America is the slide valve. However, remarkably economical engines using

poppet valves, such as are used in gas engines, are used on tractors abroad in connection with a system of superheating, and will undoubtedly be introduced into this country. The American plowing engines are all double acting — *i.e.*, steam is admitted alternately at either end of the cylinder. The valve must admit the steam, shut off the supply at the proper time, and hold the pressure while the piston moves to the other end of the cylinder, whereupon it must release the exhaust steam. The valve is often double ported so as to take steam from both ends of the steam chest at the same time. The valve is sometimes provided with a friction ring which fits tightly against the cover of the steam chest so as to prevent steam from getting on top of the valve and increasing the friction. On some tractors what is known as a balanced valve is used in order to minimize the valve friction. The valve usually opens the inlet port before the end of the stroke so that full pressure may be exerted the instant the piston starts on its return trip. On practically all engines the exhaust port is closed before the steam has entirely escaped, to form a cushion and bring the piston to rest gently at the end of its stroke.

### *Cylinder and Piston*

The cylinder is usually of cast iron, with one head cast on and one bolted. The piston is usually a hollow cast iron disk, fitted with two or three expanding rings for preventing the passage of steam between it and the cylinder wall. Since the engine is double acting, and both ends of the cylinder are closed, the piston rod moves back and forth through a stuffing box in the cast-on cylinder head, remaining parallel to the engine frame. The connecting rod necessarily assumes various angles during the revolution of the crankshaft. The wrist-pin joining the piston rod and connecting rod is carried by the cross-head, the shoes of which move back and forth between curved guides, which are usually cast with the cylinder as

part of the engine frame. A removable cover usually excludes dust and grit from the cross-head and guide.

### *Control of the Engine*

If steam were fed at boiler pressure during the entire stroke it would convert only about 8 per cent. of its energy into work. For the sake of economy it is therefore necessary to admit steam during only a part of the stroke and allow it to expand during the remainder. An engine working at its greatest economy will cut off the admission of steam at from two fifths to one half its stroke. The throw of the valve which accomplishes the variation in cut-off is under easy control of the operator. Where greater power is needed, the steam can be fed at practically boiler pressure the whole length of the stroke, and an enormous increase in power may be had, provided the boiler will continue to generate sufficient steam. This accounts for the great elasticity of steam for plowing and traction purposes as compared to the internal combustion engine, which will be discussed later.

The motion of the valve must be controlled in order to reverse or stop the engine and to vary the point of cut-off. The means employed to reverse the valve motion can be used in intermediate positions to control the throw, and in neutral position to stop the action of the valve entirely. Since a separate crank for operating the valve is out of the question, an eccentric takes its place. This is simply a sort of crank formed by setting a disk off centre upon the crankshaft. The throw, or eccentricity, of the disk is twice the distance from the centre of the crankshaft to the centre of the disk. The valve push rod is driven by a strap which fits around the eccentric. It is evident that if the disk could be rotated about the shaft it would give the valve more or less throw, and eventually cause it to move in the opposite direction. However, the setting of a valve is rather a delicate operation, and since the average operator is none too well qualified, a great many

manufacturers key the eccentric immovably to the shaft. For convenience, a quicker method of shifting is required anyhow.

### *Reverse Gear*

The two systems of reverse in common use are the single and double eccentric. The latter has two opposed eccentrics connected by suitable straps and push rods to a vertical curved link. Sliding in this link and connected directly to the valve is the link block. By lifting the link, or lowering it, the link block and valve will be actuated by first one and then the other of the eccentrics. This system contains a few more parts, but if provided with removable bushings it proves durable, and its simplicity and economy of steam make it very popular. In the single eccentric reverse the eccentric strap carries an extension, at the end of which is carried a pivoted block or roller. This is free to slide in a pivoted guide which drives the push rod. The angle of this guide may be shifted by the reverse lever so as to control the throw of the valve and reverse the engine.

### *Crankshaft*

On a single cylinder engine the crankshaft is usually provided at one end with a disk which carries a crankpin at a point near the rim. This is also known as a side crank. A double engine has also a centre crank, similar to that on gas engines—*i.e.*, practically a bend, drop-forged in the shaft. The crankshaft should be supported by ample bearings, set as closely as possible to the crank. The proper diameter of the crankpin, upon which the force of the connecting rod comes, is given by good authority as at least one fourth of the cylinder bore, and the length as one third that of the cylinder.

### *Flywheel and Clutch*

The flywheel is commonly attached to the crankshaft so that it revolves whenever the engine is in motion. It is usually



wide enough to support an eight to twelve inch belt for driving stationary machines. It is evident that a friction clutch must be used which will allow the power to be applied gradually to the traction gearing, otherwise the starting of a heavy load of plows would require great care and considerable time. This clutch is usually made up of two or more shoes, and the necessary collar and toggle levers for holding them against the inside face of the pulley or flywheel. The blocks or shoes are usually of wood and frequently faced with some special friction material. When the clutch is thrown in it locks itself in position without strain on the clutch lever. Some clutches are fitted with counter weights, which lift the shoes from the face of the pulley by centrifugal force as soon as the clutch is thrown out. Means are provided for taking up the wear on the shoes so as to keep the clutch effective at all times.

#### TRANSMISSION

The power is usually transmitted to the traction wheels by a simple train of spur gears — *i.e.*, cylinders with teeth cut on the circumference parallel to the axis. A driving pinion is attached to the friction clutch. This engages an intermediate gear, and this in turn a large compensating gear on the countershaft. Pinions on either end of the countershaft drive the large master gears, which are fastened to the traction wheels by either rigid or spring connections. On a few engines the power is taken from both ends of the crankshaft and transmitted by two complete sets of gears, making what is properly known as a double-geared engine. The intermediate shaft on late types is attached to the same wing sheets as the engine frame.

#### *Differential Gear*

At some point in the transmission there must be a differential, or compensating, gear to allow one drive-wheel to revolve

faster than the other at times, and both to receive power equally when moving straight ahead. This is necessary because of the unequal slippage of the two wheels in soft ground and the unequal travel in turning. The differential consists (1) of a large spur gear mounted loose on the countershaft or axle; (2) a series of small bevel or spur pinions mounted between the spokes of the main gear; (3) two gears standing in a vertical plane in mesh with the small pinions between and mounted on the shaft or axle. One of the two latter gears is keyed to the shaft, and the other to a sleeve revolving upon the shaft. Each is connected directly or by gears with the drive-wheel on that side. When both drivers move at the same rate, the small pinions do not revolve. When one wheel lags, the two compensating halves revolve in opposite directions to equalize the travel, and the main gear continues to transmit power to both sides. The differential, or counter, shaft is usually continuous, and the compensating halves and pinions beveled. When spur pinions are used, one compensating half is internal and one external — *i.e.*, the teeth of the one extend toward the main shaft and the other outward, the spur pinions being arranged in pairs between. One small pinion in each pair meshes with each gear, the two pinions being side by side on a stud parallel with the countershaft.

### *Mounting*

The majority of plowing engines now sold have the countershaft and rear axle mounted at the rear of the boiler. The bearings for these shafts are commonly supported either by large cast iron brackets on the corners of the fire box or by a continuous wing sheet riveted at close intervals around the top and sides of the fire box. The rear mounted engines are sometimes hung on springs and links, which relieve the jar upon the boiler and engine without allowing the gears to become unmeshed. The wheels sometimes revolve on short axles which are mounted on brackets attached to the side of the fire box.

This effects a better distribution of weight for tractive efficiency on level ground than the rear mounting, unless the front wheels of the latter type tractor are set as far forward as possible. However, the side-mounted construction is more apt to lift the front wheels from the ground on a grade, and the fire box may be dangerously weakened in the comparatively small area supporting the bracket. It is difficult to keep the stub axles rigid, and the drive-wheels tend to become closer together at the top, when, of course, the axle bearings wear unevenly and the gears are thrown out of proper alignment. Truss axles extending underneath the fire box to each stub axle relieve the strain on the fire box, but do not prevent the unequal wear on the gears. On return-flue engines the wheels are often mounted on a continuous axle ahead of the fire box. On some very successful plowing engines a separate steel frame is made to carry the engine and gearing, so as to place no strain from these sources upon the boiler. This is known as the under-mounted or frame-mounted type. It accomplishes its purpose and makes the engine accessible at the expense of greater exposure of the working parts to dust and grit.

### *Traction Wheels*

The patent expert of one of the great machinery companies once said that in building a tractor he would first build the wheel and then the remainder. The traction wheel is a fundamental point, for no matter how much power the engine may develop, or how efficient the traction gearing may be, the tractor will not be successful if the wheel fails properly to grip the ground. The effectiveness of the drive-wheel depends not only on its character, but upon the distribution of the tractor's weight. Nor will the same wheel with the same weight upon it prove equally efficient in all conditions. It has been claimed by advocates of special caterpillar and walking wheels that the slippage of the round-wheeled tractor is

never less than 6 per cent., and may reach 15 per cent. in ordinary footing; hence some have adopted extreme measures in order to produce an efficient traction wheel. For general purpose tractors, however, the problem narrows itself considerably. There are the alternatives of high or low wheels, and wide or narrow wheels, which, with the type of grouser or cleat, determine the gripping power of the wheel upon the soil.

The increasing weight of tractors which has accompanied the great increase in power has necessitated careful consideration of the weight per unit of bearing surface upon the ground. In standard tractors from two thirds to three fourths of the total weight is thrown upon the drivers when the engine is stationary, and the hitch may be so arranged as to lift considerable weight off the front wheels and place it upon the rear ones when plowing. At rest the weight per square inch of bearing surface is usually from one fourth to one third below the pressure exerted by horses at rest. In plowing, however, the bearing surface is mostly forward of the centre line of the axle, and it is probable that this weight equals, or even exceeds, the figure for a horse's hoof, which is about twenty to twenty-three pounds per square inch. In order to increase this bearing surface and, incidentally, the friction of the wheel upon the ground, wheels have been increased in diameter in order to present a longer arc in contact with the ground, and in width further to increase the area.

In extremely high wheels there is the difficulty of securing sufficient rigidity and strength without unduly increasing the weight. The low, wide wheel produces greater strains upon the axle, and is at a further disadvantage in comparison with the high wheel, in that as the tire sinks slightly into the earth the tractor must constantly propel itself and its load up a slight grade. The percentage of the radius which sinks beneath the surface represents

the grade, and the higher the wheel the less it will be affected in passing over soft ground or rough roads. In order to compromise, designers have had to sacrifice something of both advantages.

The drive wheels on steam plowing tractors are not so extreme in variation as on gas tractors, since the engines are more nearly uniform in size and weight. The wheels are usually from 24 to 36 inches wide and 6 to 8 feet in diameter, with extension rims 10 or 12 inches wide. The built-up type of wheel is most common, with steel tires, to which are attached either round or flat steel spokes, which in turn are fastened to a cast iron hub.

### *Steering Wheels*

The front wheels are usually of the built-up type, but are more often made with cast iron rims than the rear wheels. A flange or collar around the middle of the wheel prevents it from lateral slippage. Steering is done by guiding the front wheels, which are rotated with the axle by means of a chain winding shaft, worm gear, and hand wheel. At some additional cost a steam steering apparatus may be attached to certain engines whereby the heavy work of steering is performed by power and the wheels can be kept more rigidly in line.

### *Lubrication*

It is evident that different parts of the steam engine will require different methods of lubrication. Steam cylinder oil is a rather heavy liquid with a considerable percentage of animal or vegetable fat mixed with mineral oil in order to make it capable of emulsifying or mixing with the steam. It is commonly fed into the steam pipe outside of the throttle valve, and sometimes between the throttle and the cylinder as well. It may be delivered by a mechanically driven oil

pump, or by a lubricator which feeds the oil by displacing it with water. The former is preferable, as it eliminates danger from freezing and is more economical and positive in its action. On the cross-head, crankpin, and similar places a sight-feed oil cup, feeding a rather thin oil by gravity, may be employed. For lubrication of bearings, however, the tendency is to now use grease cups and hard oil or greese, which is converted into a fluid by the heat of friction. In the compression grease cup the grease is forced on to the bearing by a plate and spring, or by screwing down the cover of the cup. For lubrication of the heavy gears axle grease is frequently employed, but since this is apt to form a grinding paste with the dirt and sand which are thrown up, means of washing the gears by a drip of thin cheap oil are frequently employed.

#### *Modification of the Steam Plowing Tractor*

In some cases the traction wheels are made with removable cleats, and an attachment provided whereby a drum can be substituted for the front wheels, thus converting the engine into a road roller. Some tractors may be equipped with an attachment for running an elevator grader by the power of the engine. A level gear on the countershaft drives through a universal joint and telescopic shaft, doing away with loss occasioned by the failure of the light grader wheels to provide sufficient traction. English tractors equipped with cables for pulling plows have already been mentioned. Some American tractors have a drum and short cable for pulling stumps or lifting the engine out of difficulty. Others may be provided with a derrick and cable to fit them for pulling stumps or for steam-shovel work. Very interesting modifications of the ordinary steam tractor are used in California in the soft reclaimed tule lands. Some of these have drive-wheels and extensions up to eighteen feet in width, and front wheels up to eighteen feet wide, the entire tractor being forty to forty-five

feet wide. In other cases a type of caterpillar, or walking, wheel is made to carry the weight over ground which is so soft that horses can bring fuel and water to the outfit only over permanent roads, to which the tractor must go for its supplies.

## VIII

### PERFORMANCE OF STEAM TRACTORS

**S**TEAM-PLOWING tractors range in size from 50 to 120 rated brake horsepower, and a general ratio of brake horsepower to nominal rating is about three to one. In other words, steam tractors of the sizes used for plowing are rated at from 20 to 40 nominal horsepower. Practically every steam engine will carry at least 10 per cent. more load than is called for by the rating. Three classes of 20, 25, and 30 to 35 nominal horsepower are manufactured by most engine companies. These will handle, roughly speaking, about seven, ten, and twelve or fourteen plows, respectively. Ordinary steam-plowing engines, fully equipped and ready for work, range in weight from ten to twenty-five tons. They cost from \$1800 to \$3000 in the United States, and possibly 30 per cent. more in Canada, owing to freight and duty. Many smaller tractors are made for lighter work, but since the steam engine is not so economical in small units for plowing, the larger engines are practically the only ones which have been constructed especially for this purpose.

Some tractors are given only the brake rating, but it is customary to use the term "nominal" in rating engines for sale. This has no definite meaning, being simply the designation adopted by the manufacturer in listing his various tractors. Some tractors are rated on their actual drawbar horsepower under what may be assumed as average conditions. Naturally the matter of a tractive rating is very complex, since the conditions over which the tractor must run are widely variable.



A standard basis for tractive rating, however, would be of great assistance to purchasers, since the differences in design will enable one tractor to deliver a greater percentage of the brake horsepower at the drawbar than another. This is a matter which has been the subject of considerable discussion by agricultural engineers, but as yet no solution has been reached.

Unfortunately, no scientific tests of tractive efficiency have been conducted in this country, at least, not for the benefit of the public. The pulling power of the tractor depends on a great many different factors, such as the total weight, the weight in relation to the area of the supporting wheels, the type of transmission, and the distribution of weight upon the front and rear wheels. The tractive efficiency has usually been estimated by comparing the brake horsepower developed in one test with the tractive horsepower developed in another. However, this gives no check on the comparative amounts of power developed at the crankshaft, and is apt to be very misleading. After holding down the power of any tractor on a brake test it can be made to show a high proportion of this power at the drawbar simply by increasing the brake horsepower developed during the tractive test. This automatically increases the fuel consumption in a given length of time, hence the increased drawbar horsepower will be at the expense of fuel consumption. A more accurate but still imperfect method has been to base the tractive efficiency on the relative fuel consumption in the brake and tractive tests.

In July, 1909, during tests at Winnipeg, four steam engines had a total weight of 585 pounds per inch in width of drivers, and 456 pounds for each brake horsepower developed on economy tests. Over a firm plowing course they were able to show 56.6 per cent. as much power at the drawbar as at the belt in the economy tests. Over a hauling course, which presented nearly every possible condition of ground from pavement to sand patch, the limitation of the load by the bad spots reduced the drawbar horsepower to 29.3 per cent. of the economy

load. The ratio of fuel per brake horsepower-hour to fuel per drawbar horsepower-hour was 59.9 per cent. in plowing and 34.4 per cent. in hauling. During the two-hour hauling tests the steam tractors, traveling at from 2.04 to 2.34 miles per hour, developed individual averages of 25 to 34 actual drawbar horsepower in moving the dead weight of other steam tractors rated at from 25 to 36 h.p., one engine being used as a load in each case. In plowing tests conducted in 1910, six steam tractors plowing on firm sod ground showed a tractive efficiency, based on comparative fuel consumption, of practically 48 per cent. These figures quite effectively illustrate the tractive efficiency which may be expected of the average steam tractor in conditions where the footing is neither the very best nor the very worst that might be found.

A mean of percentages indicates that the weight borne by the drive-wheels of the steam tractors at Winnipeg in 1910 was about 73.5 per cent. of the total. In plowing, the steam tractors showed an average drawbar pull of 26 per cent. of the total weight and 36 per cent. of the weight on the drivers. In plowing, the preceding year, the drawbar pull was approximately 11 per cent. of the total weight in hauling and 22 per cent. in plowing. Averaging the plowing and hauling tests for 1909, the steam tractors have credit for one tractive horsepower for each 1033 pounds of total weight.

Steam tractors are as a rule geared to run somewhat higher than gas tractors, but owing to the many delays incident to starting and taking on supplies, they actually net only about 15 miles of furrow travel in ten hours as compared to 17.5 for the latter. In the various motor contests, however, where the start has been made with steam up, and every facility provided for keeping outfits in motion, the steam outfits as a whole have shown higher net speeds than the gas tractors.

The indicated horsepower of steam tractors is sometimes specified, and in general practice the indicated horsepower will be from 20 to 25 per cent. above the manufacturer's brake

rating. The mechanical efficiency will range from 85 to 93 per cent. In the Winnipeg motor contest of 1910 the steam engines carried an average of 97 per cent. of their rated brake horsepower in an economy test and 132 per cent. in a maximum test. The drawbar horsepower was 95 per cent. higher than the nominal rating. Steam tractors are not as a rule over-rated. However, their power for steady work is much less than could be maintained on a short run, unless a much larger boiler is provided than usual for a given size and speed of engine.

Steam tractors have competed in three motor contests held in Canada during the last several years. The following table shows the average coal and water consumption of all engines in the economy tests in these competitions. It is not to be supposed that the load in every case was exactly at or even near the point of greatest economy, though this condition was usually aimed at. There was but one test of a compound engine on the brake, against six single and eleven double cylinder engines. In plowing there were four single and six double; and in hauling, one single and three double. To these figures there should be added a certain percentage of coal and water used in actual practice in getting up steam, and for waste after the close of the day's work.

POUNDS OF COAL AND WATER USED PER DELIVERED HORSEPOWER PER HOUR

Test	Single Cylinder		Double Cylinder		Compound	
	Coal	Water	Coal	Water	Coal	Water
Brake.....	3.72	30.11	4.43	32.43	4.96	34.94
Plowing.....	7.46	52.8	8.87	69.0	—	—
Hauling.....	14.18	114.6	12.84	91.1	—	—

Steam tractors as a rule use from seven pounds to eight pounds of water per pound of coal. Reports from 333 plowing engines of all types in the United States and Canada indicate

an average of 7.67 lbs. Twenty-four public brake tests show a mean of 7.78 lbs.; sixteen plowing tests 7.08 lbs., and four hauling tests 7.4 lbs.; or a mean of 7.42 lbs. for the forty-four tests. Single-cylinder engines show a range of from 5.78 lbs. to 9.97 lbs.; and double-cylinder from 3.3 to 10.3, according to official reports. Conditions were such however, as to arouse doubts as to the accuracy of such extreme figures. By making enough assumptions one can compare these data with those furnished by operators of eleven oil-burning steam engines in California. These men report the use of 9.4 gallons of water per gallon of oil. Assuming the oil to be of 20° Baumé and to contain 20,000 B.t.u. per pound, they used 1990 B.t.u., in evaporating one pound of water. The ordinary run of coal used contains not over 13,000 B.t.u. per pound; hence 1700 to 1740 B.t.u. would be furnished per one pound of water.

The cost of operating a steam tractor varies even more widely than that of operating the gas tractor. The various conditions are fully covered in Bulletin 170, United States Bureau of Plant Industry, from which the average performance of steam tractors as shown in 1907 and 1908 can be ascertained. The following quotation gives quite accurately what may be expected of steam tractors taken as a class, except that the great improvement in both engines and plows, even in the short interval, has added greatly to the efficiency of outfits. In addition, the rapid education of operators, the improvement in other equipment for use with engines, and the tendency to use the tractors for a longer period of time each year, would all help to increase the performance and reduce overhead charges.

#### AVERAGE RESULTS WITH STEAM-PLOWING OUTFITS

In view of the extreme variation in conditions encountered by individual operators, any averages of results must be taken with due regard for local conditions. The following table presents a summary of the data taken from reports complete enough to give the desired information. These include results

for a part of the season of 1908. For the purpose of comparison, two columns are shown for Canada. The first is from direct reports from operators. In the second column averages are taken from the annual traction-plowing numbers of the *Canadian Thresherman and Farmer*, from 1905 to 1909, inclusive, and represent 214 letters of steam plowmen in answer to that journal's annual circular letters on this subject. A small percentage of the letters are duplicated — that is, they are from the same operator in different years — and several correspondents reporting under column 1 are also found under column 2. The average of coal used given in column 2 is from 150 operators, many using either wood or straw or not reporting at all. Those using wood report about two cords a day as an average. The average number of barrels of water used by Canadian operators apparently varies greatly. However, a difference in standards may explain the variation. If the 72.8 barrels in column 1 were of 31.5 imperial gallons of 10 pounds each, and the 57.1 barrels in column 2 were of 42 imperial gallons, the water used per pound of coal would be 7.21 and 7.82 pounds, respectively. It is difficult otherwise to account for such a wide variation.

## COST OF PLOWING WITH STEAM ENGINES

*Data in reference to steam-plowing outfits operated in California, in the Southwestern and the Northwestern sections of the United States, and in Canada.*

WORK ACCOMPLISHED, ETC.	CALIFORNIA	SOUTHWEST	NORTHWEST	CANADA	
				1	2
Number reporting.....	11	100	60	23	214
Acres plowed annually for self.....	2,800	475	310	379	.....
Acres plowed annually for others.....	689	580	348	628	.....
Acres plowed annually, total	3,489	1,055	658	1,007	.....
Percentage of custom plowing	20	55	53	61	.....
Size of engine (horsepower) <sup>1</sup>	110	26.46	27.5	29	27.28
Cost of engine.....	\$5,500	\$2,680	\$2,505	\$3,420	.....
Number of plows.....	23.3	.....	9.85	11	8.6
Width of furrow cut (feet) <sup>2</sup> ..	20.45	12.8	11.18	12.83	10.03
Cost of plows <sup>1</sup> .....	\$506	\$451	\$657	\$860	.....
Hours of work each day....	10.6	11	11.44	12.31	.....
Miles covered each day <sup>3</sup> .....	20.4	16.4	16.9	13.8	16.75

<sup>1</sup> Brake horsepower. Nominal or tractive rating about 60 horsepower.

<sup>2</sup> Less than one-fifth of the outfits reported in the Southwest use moldboard plows. These average 9.18 bottoms, cutting 10.7 feet, and cost \$561 each. From 10 to 20 disk plows would be used to cut the average of 13.2 feet reported. These sets average \$428 in price. The figures in the table are for the average of both types.

<sup>3</sup> "Miles a day" is miles traveled with plows in the ground, as figured from the daily acreage and the average width of the furrow. The distance traveled in turning, etc., is not included.

## POWER AND THE PLOW

WORK ACCOMPLISHED, ETC.	CALI-FORNIA	SOUTH-WEST	NORTH-WEST	CANADA	
				1	2
Acres covered each day . . . . .	50.6	25.7	22.9	21.4	20.37
Days of plowing for the year . . . . .	69	41	29	47	.....
Men employed . . . . .	6	3.43	4.24	4.11	4.64
Horses used . . . . .	5.5	3.1	4.5	3.9	3.36
Labor and board (by day) . . . . .	\$16.50	\$11	\$14	\$14	.....
Quantity of fuel used each day <sup>1</sup> . . . . .	7.16	2,508	2,735	3,151	3,064
Quantity of fuel used for each acre <sup>2</sup> . . . . .	0.14	98.4	126.6	147.4	150.4
Cost of fuel for each day . . . . .	\$7.28	\$6.91	\$8.71	\$8.34	.....
Cost of fuel for each acre . . . . .	\$0.144	\$0.273	\$0.38	\$0.39	.....
Quantity of water used each day . . . . .	3,367	74.1	77.75	72.8	57.1
Cost of oil, etc., for each day . . . . .	\$1.00	\$0.57	\$0.59	\$0.87	.....

<sup>1</sup> For California expressed in barrels of crude oil; elsewhere in pounds of coal.

<sup>2</sup> For California expressed in gallons; elsewhere in the United States in barrels of 31.5 gallons.

The data for 1907 and 1908 under column 2 are much nearer the figures contained in first-hand reports from the Northwest and Canada, as is to be expected in view of the time covered by the latter. For these two years the averages of data contained in 118 letters show the size of the engine to be 27.7 horsepower; number of plows, 9.09; width of furrow, 10.6 feet; miles a day, 16.75; acres a day, 21.52; number of men, 4.53; number of horses, 3.57; quantity of coal a day, 3245 lbs.; quantity of coal for each acre, 150.8 lbs.

It will be noted that from three to six men are needed in operating a steam plowing outfit. A full crew would consist of an engineer, fireman, plowman, cook, and two or more men with teams to haul coal and water. Wages range from \$1.75 for ordinary help to \$4 or \$5 a day for the engineer, though many receive more than that. Horses cost about \$1.00 a day each, and board costs from 50 cents to 75 cents for each man. The Bulletin just quoted estimates the cost of steam plowing in 1907 and 1908 at 85.3 cents per acre in California, \$1.14 in the Southwest, and \$1.73 in the Northwest, averaging the entire season's run of both sod breaking and stubble plowing, and figuring all overhead charges on the basis of about seven years' life of equipment. With gas tractors of smaller size, under the same conditions, the cost was estimated at \$1.12 for the Southwest and \$1.46 for the Northwest, the differences being due largely to the more rapid work accomplished with disk plows and a lower cost per unit of fuel.

## IX

### FUELS FOR STEAM TRACTORS

**T**HE fuels for steam tractors which are in common use include coal, straw, wood, and crude oil. Anthracite coal is seldom used, the ordinary grades ranging from lignite, which is a very soft, peaty product, to the highest grades of bituminous steam coal. The cost of coal naturally varies widely in different sections, as well as the grade which is commonly used. In some sections of Montana and the two Dakotas cheap coal, both lignite and a better grade, are to be found underlying large areas. The quality is not such as to encourage extensive shipping, consequently local mines supply coal at from \$2.00 to \$3.00 per ton. Coal which is shipped in from the Eastern mines costs as high as \$8.00 or \$9.00 per ton at the railroad station, but will usually produce as much power as one and one half to two tons of the local product. In the Southwestern States of the Great Plains area the coal is usually brought from Missouri or Oklahoma fields and costs in the neighborhood of \$6.00 per ton, plus the cost of hauling. In Iowa and Missouri, where a fair grade of bituminous coal is obtainable, the price is usually around \$4.50 to \$5.00 in carload lots. It is the custom of many steam engine operators to have the coal delivered in carload lots and stored in a dealer's warehouse, whence it is hauled as needed. Coal may be had from \$3.50 to \$4.00 per ton in carload lots in Illinois, Indiana, and Iowa, although little steam-traction plowing is done in this section.

Bituminous coals, such as are ordinarily used in plowing

contain from 12,000 to 14,500 B.t.u. per pound. The best coal contains from 80 to 90 per cent. of carbon and hydrogen.

Crude oil and its products are nearly pure carbon and hydrogen in varying proportions. Wood and straw contain only about 50 per cent. of carbon. A large part of the possible oxidation has already taken place in the latter, hence their heating value is low. Alcohol, as it will be seen later, comes from vegetable materials and has also a lower thermal value than coal and oil. Were it possible for all engines to utilize all fuels with equal efficiency, the steam engine would have a tremendous advantage on account of the cheapness of its fuel. If its energy could all be utilized, one pound of coal, costing two fifths of a cent and having 14,000 B.t.u., would produce about eleven million foot-pounds of work, or approximately the useful work of one horse for one day.

Straw is used only where it has no value for feeding or bedding purposes, consequently straw-burning engines are commonly found only on the Great Plains. If we disregard the fertilizing value of the straw, the use of it in engines is a source of economy, as the first cost of coal is saved. The labor of keeping the engine supplied with straw is practically the same as the average for hauling coal from the railway station. The use of straw in plowing is not convenient, as a large tender must be carried for rounds of any length. For threshing, however, it is convenient and cheap. Straw contains about 8000 B.t.u. per pound, or a little more than half the heat value of the best grades of coal. It requires somewhat more skill in firing than does coal, owing to the rapidity with which it generates heat.

Wood is used to a very limited extent in plowing, owing to the scarcity of timber on most of the Great Plains area. Where abundant, however, it can be used at the rate of about two and one fourth pounds of wood for one pound of coal. Air-dried wood will net about 5000 to 6000 B.t.u. per pound. Fresh wood contains from 30 to 50 per cent. of moisture, according to species, and seldom dries in the air to less than 20



per cent. The heat required to evaporate this must be deducted from the 8000 to 8500 B.t.u. which will be contained in a pound of good air-dried wood. A cord of 128 cubic feet of ordinary wood contains 60 to 80 cubic feet of solid wood. When thoroughly air dried, hickory or hard maple weighs about 4500 lbs.; white oak, 3850 lbs.; birch, red oak, or black oak, 3250 lbs.; poplar, chestnut, or elm, 2350 lbs.; and average pine, 2000 lbs.

Crude oil makes an excellent fuel, being cheap, highly concentrated, and easily handled. The usual cost is from two to three cents per gallon, which will usually weigh about seven and one half pounds and contain about one and one half times as many heat units per pound as the best steam coal. Many builders of steam tractors furnish attachments for converting coal-burning engines into oil burners. The usual method is to mix oil and steam by forcing them through a jet located in the fire box, the vapor burning readily and producing an abundance of heat. Oil is used almost entirely by steam plowing tractors on the Pacific coast, but not extensively elsewhere.

## X

### THE INTERNAL-COMBUSTION TRACTOR

**T**HE third great source of power for direct traction plowing is the internal-combustion tractor, which differs from the steam tractor in the kind of fuel used and the method of transforming the chemical energy in that fuel into mechanical energy for useful work. We have seen that in the steam engine the heat is applied externally to a vessel containing some liquid medium, ordinarily water. The temperature of the water is thus raised above the vaporizing point. The resulting gas is admitted to the cylinder under pressure and performs work by its expansion and cooling. The internal-combustion engine admits the fuel directly to the working cylinder, where it is vaporized. It is compressed to a density of four or more atmospheres and ignited. The combustion is practically instantaneous; hence the pressure rises with the force of an explosion behind the piston. The action may be compared to that of a gun, the piston taking the place of the bullet, but constantly returning to be acted upon again. The gases work directly upon the piston; hence there is little chance for loss of heat by radiation, as is the case at every step in the steam engine cycle, and much greater efficiency is the result.

The essential parts of the internal-combustion engine consist of a cylinder and movable piston, with means for vaporizing the fuel and delivering it to the cylinder; for regulating the power of the engine; for igniting the charge; for allowing the charge to enter and the burned gases to escape; for cleaning

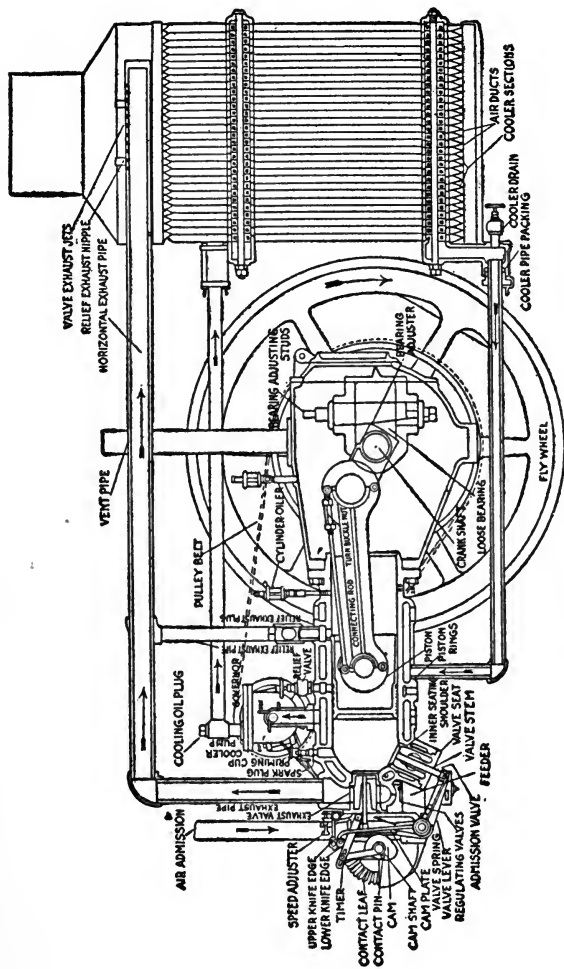

Sectional view of engine

the cylinder after the explosion; for transforming the movement of the piston into rotary motion suitable for driving machines, and for lubricating the engine to reduce friction. In other words, we must have a cylinder, cylinder head, piston, fuel supply, carbureter, governor, ignition system, valves, cooling system, wristpin, connecting rod, crankshaft, flywheel, and lubricating devices, with a base for the support of all these parts.

In the early nineties, or shortly after the gasoline engine was first successfully used for stationary purposes, a tractor equipped with such an engine for power was offered for sale. This proved unsuitable in many respects, and, since at that time there was much competition from steam threshing engines and little demand for a plowing tractor, the venture did not survive. At least ten years elapsed before the gas tractor proved at all successful commercially. The year 1903 really marks the beginning of the great development of gas tractors, which has been one of the marvels in the history of agriculture. By the spring of 1908 the builders of the first successful tractor had about 300 machines in the field, and the sales that year equalled those of the five years preceding. The following year the number in the field was again doubled, and by the close of the year 1910 over 2000 of these tractors were said to be in active service. Another company began to produce a small tractor in 1907 and by the close of the decade was selling several thousand yearly. Dozens of gas tractor factories sprang up, and practically every manufacturer of steam traction engines either went out of business or added an internal-combustion engine to his line. At present over sixty firms are offering gas tractors to the public and the number is being added to almost weekly. For plowing purposes there is little question that this type of prime motor has taken a permanent lead over the steam engine. On that account, and because of the comparative newness of the field, the mechanical features of the gas tractor will be dealt with in greater detail.

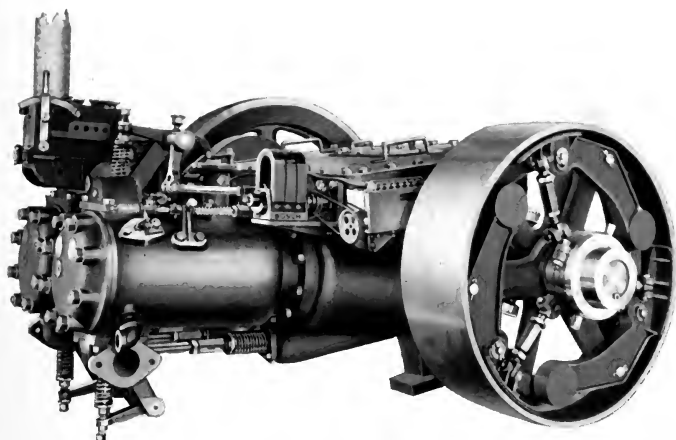
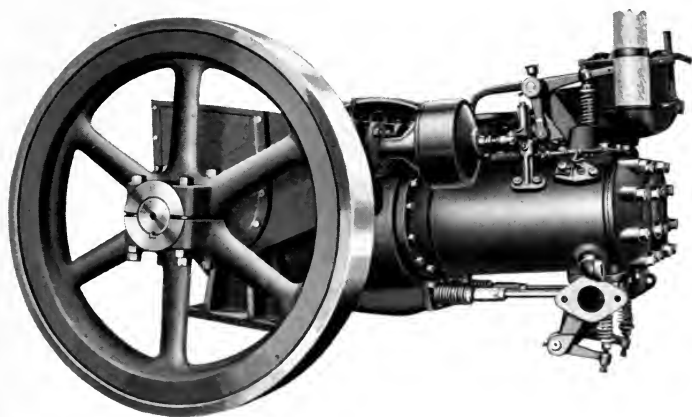

### GAS TRACTORS

Left-hand side of motor plant  
Right-hand side of motor plant



The fundamental principles of the internal-combustion engine are the same, no matter what fuel is used, and for convenience we may speak of it as the gas engine. The class may first be divided into the two-cycle and the four-cycle types. By a cycle we mean a complete series of events in which one working stroke occurs. In the two-cycle engine the charge is drawn into a separate chamber, usually the crank case, and there partially compressed by the outward movement of the piston. At the end of its working stroke the piston uncovers a port in the cylinder which is connected by a side passage with the crank case, and forces a charge into the combustion chamber. At the same time it opens a port on the opposite side of the cylinder, out of which the exhaust gases rush while the incoming charge is filling up the combustion chamber. A projection on the end of the piston deflects the new charge toward the head end of the cylinder, with the result that the cylinder is more effectively scavenged of the burned gases, which would tend to dilute the fresh mixture. As the piston is carried back through the force of the flywheel, the charge is compressed in the cylinder and ignited at the proper time. Thus a working stroke occurs to each revolution of the flywheel, or to each two strokes of the piston.

The two-cycle principle is used largely on marine engines, where lightness and compactness are the prime essentials. It is used on tractors to a very limited extent. Having twice the number of power strokes at a given speed, the two-cycle engine will naturally deliver more power than the four-cycle. However, owing to the difficulty in combining the suction, power and exhaust strokes in one, the power developed is only from one third to three fourths more than would be obtained from a four-cycle engine of the same dimensions and speed. This type is also less economical of fuel.

In the four-cycle engine, which is practically universal on tractors, the piston moves outward on what is known as the suction stroke, during which a charge is drawn into the cylinder.

On its return trip it compresses the charge into a small clearance space at the head of the cylinder. At a point usually previous to the end of the compression stroke, the charge is ignited. By the time the piston starts outward on the third, or power, stroke, the full force of the explosion is exerted against the piston head. As the flywheel again carries the piston backward, the exhaust valve opens and the burned gases are expelled from the cylinder, thus completing the cycle. There is but one power stroke to four strokes of the piston; hence the name. It will be seen that on the suction stroke the exhaust valve is closed and the inlet valve open. On the exhaust stroke the inlet valve is closed and the exhaust open. One automobile manufacturer has aptly compared the four-stroke cycle to the operations involved in firing an old muzzle-loading rifle. First, the charge is admitted, and next it is rammed home. The third step is the firing and the fourth consists of swabbing out the gun barrel.

#### DESIGN OF GAS TRACTORS

The gas tractor consists essentially of power plant and traction mechanism. The former consists of the same essential parts as a stationary gas engine, while the latter includes the supporting frame, wheels, shafting and gearing for transmitting power to the traction wheels. At the present time there are probably one hundred distinct types and sizes of gas tractor. Variations in design are so great that a strict classification would be extremely complicated, and for general purposes they are roughly divided into low, medium, and high speed types, with a further class for those of special nature. For tractors of standard types the above classes correspond quite closely to the single, double, and four cylinder classes, and to a less extent represent the power developed, the single-cylinder engines as a class being the smallest and the four-cylinder the largest.

The engines on single-cylinder tractors usually run at from 220 to 300 revolutions of the crankshaft per minute. The two-



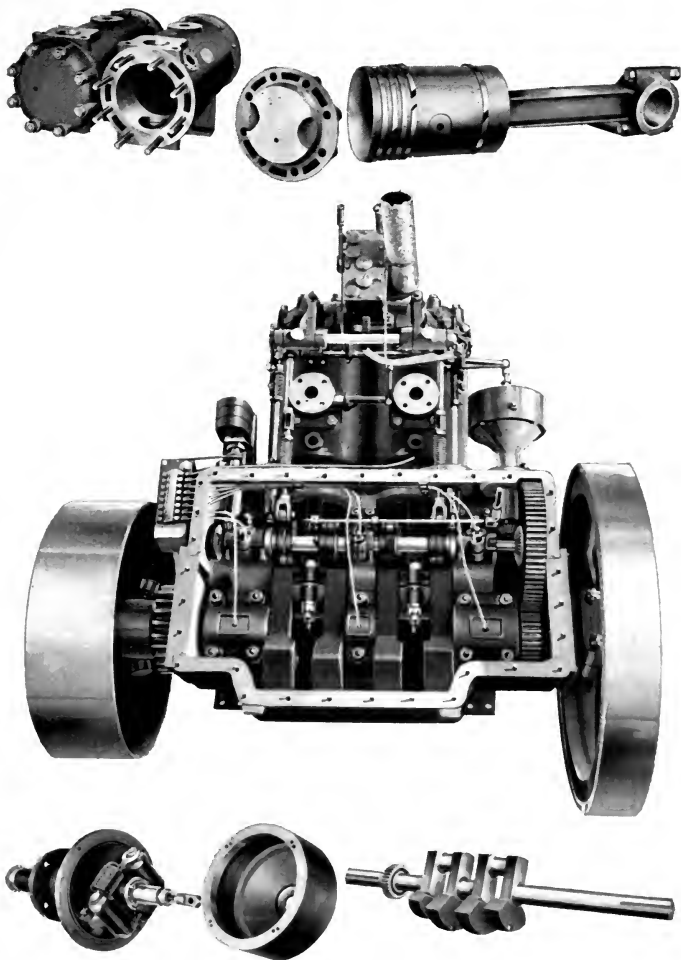

DETAILS OF THE GAS TRACTOR

Twin cylinders

Piston and connecting rod

Top view of twin cylinder-engine  
showing method of lubrication

Governor

Crankshaft



cylinder engines range from about 300 to 400 r.p.m., the three-cylinder a trifle higher, and the four-cylinder from 450 to 600 r.p.m., though these limits are by no means absolute. The speed is based largely upon the piston travel, which ranges from about 600 to 750 feet per minute. The multiple-cylinder engines are usually smaller in diameter and stroke; hence require a higher speed to accomplish the desired piston travel.

The cylinder, even on a low or medium speed tractor, is seldom over twelve inches in diameter, owing to the difficulty of cooling larger sizes through the cylinder wall. The stroke of the piston is usually longer in proportion to the diameter in the lower speed engines, the ratio ranging from an average of about 1.65 for the low speed single-cylinder tractors to 1.5 for the medium speed, and 1.15 for the four-cylinder high-speed engines.

#### GOVERNOR

Excellent regulation is especially necessary on a gas engine, where perfect combustion, clean cylinders, and economy of fuel depend upon a good mixture at all times. Only two systems of governing are in common use on tractors. In one of these a fuel charge is taken for each cycle until the speed of the engine runs above a certain limit. Thereupon the explosions are automatically cut out until the speed drops below normal. This sequence of power cycles and idle cycles gives rise to the name of "hit-and-miss" governing. This system is economical of fuel, especially on small engines, but naturally is not adapted for work requiring close regulation. It is better adapted to plowing than to threshing, sawing, and other stationary work, where a constant speed must be kept in spite of great variation in the load. An ordinary fly-ball governor, driven in some way by the flywheel or crankshaft, is commonly used. The governor weights act through suitable push rods, which in turn may lock the fuel valve so as to choke off the supply or else will prevent a spark while retaining an unexploded charge in the cylinder.

The other method of governing is that of taking and exploding a charge at each cycle, the amount taken in varying with the requirements of the load as in the throttle-governed steam engine. This method is used on practically all of the high-speed engines and some of the low and medium speed types. It is capable of very close regulation and is more sensitive than the hit-and-miss to the requirements of irregular loads. Many tractors are equipped with devices for changing the speed of the engine while in motion by controlling the governor.

#### CARBURETER

The object of the carbureter is to mix fuel and air in the proper proportions to form an explosive mixture. If the gover-

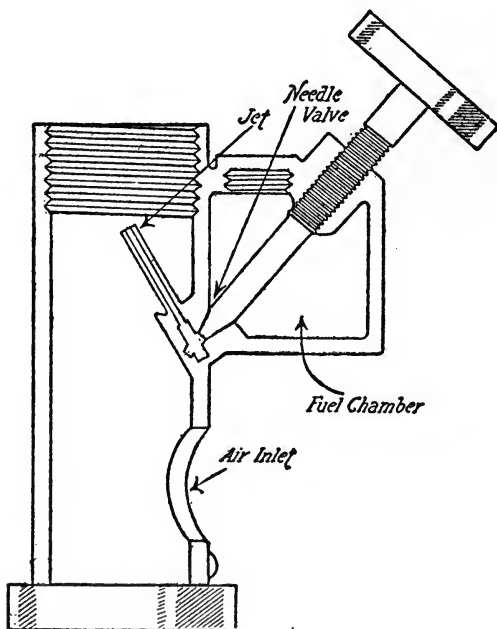

Principle of the carbureter



### TYPES OF GAS TRACTORS

Four cylinder vertical motor

A self-contained motor plow

Bevel gear and chain driven tractor with three cylinder motor



nor is the heart of the engine, then the carbureter may be said to be the lungs, which bring the life-blood and oxygen into the necessary contact. Of the three general classes of carbureter, only one is used to any extent upon tractors. This is the spray type, which divides the fuel into a fine mist rather than a true gas. The carbureter must deliver the fuel to the cylinder in proper proportions, at any speed or load, regardless of variations in the temperature of fuel and air, the difference in density in the air at different times and altitudes, and the wide extremes in the volatility of fuels secured from different sources. In order to meet all the varying requirements, many carbureters are so complicated and delicate that they are not suitable for the rough work which a tractor is called upon to do.

In brief, the spray carbureter delivers the fuel through a small opening or needle valve, situated in a passage through which air rushes, in obedience to the difference in pressure between the outside air and the contents of the cylinder on the suction stroke. The fuel is atomized by the air current and turned into gas by the heat of the cylinder. Gasoline is sufficiently volatile to give an explosive mixture in a cold cylinder. Kerosene requires more heat for its evaporation; hence it is usually necessary to start on gasoline or alcohol and switch to kerosene after a half minute's run. Sometimes two carbureters are provided for starting, but a simpler way is to add a gasoline compartment to the kerosene carbureter.

The majority of carbureters are designed to overcome the fluctuation in outside conditions by keeping the air and fuel at a constant temperature, through heat from the water jacket or exhaust pipe. All are provided with a wide range of adjustment, and some meet the many different conditions automatically. Most carbureters provide for a constant quality of mixture — *i. e.*, a fixed proportion of fuel and air. However, on a throttling governed engine, running at high speed and taking full charges, the compression is considerably increased

To prevent preignition, and at the same time make the fuel do the increased work of which it is capable at the higher compression, the tendency is now to adopt a form of carbureter which will automatically vary the quality as well as the quantity of the mixture under different loads. This type of carbureter, intimately connected with a positively driven governor, has given excellent regulation, approached only by first-class steam engines in large stationary plants. The numerous adjustments are being dispensed with and the simple expedient of controlling the vacuum in the carbureter has been adopted. This is accomplished by varying the relative proportions of the passages from the atmosphere to the carbureter, thence to the cylinder. Substantial sliding plates directly connected with the governor displace many of the delicate parts which formerly handicapped the tractor in rough work. The uniform conditions in the cylinder, which are thus obtained, allow the use of gasoline, kerosene, or even heavier oils under a wide range of conditions.

It has been stated by eminent authority that some heating apparatus is necessary in order to vaporize kerosene successfully. However, at the present time, thousands of tractors are working in the field on gasoline, kerosene, or distillate without changing the carbureter and without requiring heat for the action of the latter. Both "hit-and-miss" and throttling governors are employed on kerosene engines, in spite of other high authority to the effect that a change must be taken at every cycle to prevent cooling and loss of efficiency.

#### FUEL SUPPLY

In some tractors the fuel is delivered to the carbureter by gravity, the carbureter being required to control the supply to the cylinder against the pressure of the liquid in the tank. This method does away with fuel pumps and additional piping, but is not positive in its action, as the pressure varies with the





### TYPES OF GASOLINE TRACTGR

Single-cylinder tractor  
 Motor plow  
 Twin cylinder tractor with open  
 radiator  
 Farm truck

Tractor with opposed cylinder  
 High speed tractor with closed  
 radiator  
 Tractor with self-steering device  
 Auto-pulverizer



height of the oil in the tank. Plunger, centrifugal, and rotary gear pumps are used successfully to deliver fuel. Owing to the rapid deterioration of leather when exposed to gasoline, the pumps are usually without leather valves.

#### IGNITION

Having secured a proper proportion of fuel and air in the cylinder, the next problem is to ignite it at such a point during the compression stroke as to allow the charge to be fully ignited as soon as the piston starts upon its third, or working, stroke. This point, in a high-speed engine, or one using a slow-burning mixture, may be as much as one eighth of a revolution of the flywheel before the end of the compression stroke; or, as more often stated, 45 degrees before dead centre. Kerosene engines and those using a "lean" mixture (one with a low proportion of gasoline to air) are ignited early.

Of the many types of ignition only two, both electric, are used to any extent on tractors. These are the jump spark and the make-and-break systems. In the former a high tension current is employed. A spark coil and condenser are used to increase the tension and a vibrator rapidly opens and closes the circuit, causing the electric current to leap across the gap between the ignited points, thus forming a spark which explodes the mixture. This system is free from the difficulty of using delicate moving parts on an engine which is exposed to very severe conditions. On the other hand it involves more complicated wiring and greater danger of short circuit, besides being less easily comprehended by the average farmer.

The make-and-break system commonly uses a low tension current which passes through a pair of electrodes fitted to a plug inserted in the cylinder. One

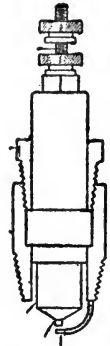

Ignition plug

of these is fixed and the other movable. At the proper point in the cycle the points of these electrodes are separated by a violent blow and the current leaps across in an arc hot enough to fire the charge.

The current is commonly produced by either a wet or dry battery, a magneto, or a small dynamo, which is sometimes termed an auto-sparker. On small stationary engines batteries are often used alone, but as these deteriorate rapidly, they are used on larger engines simply for starting, current afterward being supplied by mechanical means. The dynamo is less frequently used than the magneto. Both are usually gear-driven, as it is of the utmost importance that they be kept in exact time with the events in the cycle.

#### CYLINDER

In single-cylinder engines it is customary to place the cylinder horizontal. Double-cylinder engines have cylinders arranged in pairs and set either vertically or horizontally. Some are set on a slight incline from the horizontal. In what is known as the opposed type, the cylinders are placed horizontally on opposite sides of the crankshaft. All of the three cylinder tractors now on the market empty the cylinders vertically. In some cases they are set lengthwise and in other cases crosswise of the frame. The following arrangements are found in four-cylinder engines:

(1) Cylinders vertical with crankshaft lengthwise of the frame.

(2) Cylinders vertical and set crosswise.

(3) Cylinders horizontal with crankshaft crosswise to the frame.

(4) Cylinders horizontal with one pair opposed to the other, the crankshaft being crosswise to the frame. The first class is by far the more numerous.

The cylinder is commonly made of cast iron and provided

with a water jacket through which a liquid cooling medium circulates. The cylinder may be provided with a removable head or the head and cylinder may be cast in one piece. The removable head permits easy inspection of the interior of the cylinder, while the cast-on head obviates difficulty from imperfect joints between the cylinder and the head. Owing to the inaccessibility of the one-piece cylinder and the higher manufacturing cost, the great majority of tractor cylinders are provided with the removable heads. One tractor has a separate liner for the cylinder so that in case it becomes badly worn or warped it may be removed without substituting an entire new cylinder. Cylinders are usually cast separately and bolted to the base or crankcase, though in four-cylinder engines they are frequently cast in pairs.

#### VALVES

The valves of gas tractors are of the poppet, or mushroom, type. They may be set in the cylinder head, in the cylinder walls, or in a vertical engine, in a chamber projecting to one side of the cylinder. They are set to act vertically, wherever other features of design will permit, in order to avoid unequal wear on the valve stem guide, followed by imperfect seating of the valve. By having the valves in the cylinder head they may be removed with the head for examination. Where the valves are placed opposite each other on the sides of the cylinder they are usually provided with removable seats or cages, so that a valve may be examined without taking off the cylinder head. The valve cage contains a seat for the valve and a guide for the valve stem, which, especially in case of the exhaust valve, is usually surrounded by a water jacket. The intense heat of the exhaust is otherwise apt to cause the valve stem to warp and stick in its guide. The inlet valve is also frequently jacketed to prevent too early expansion of the incoming charge and consequent decrease in the heating value

of a cylinder full of gas. The inlet valve is frequently automatic — *i. e.*, opened by the suction of the piston — but in the majority of higher priced tractors both inlet and exhaust valves are mechanically operated. The controlling mechanism usually consists of a rocker arm and push rod, driven by an eccentric or cam. The camshaft is driven by gears from the crankshaft, but at a lower speed than the latter. In case of valves set in an offset chamber, the rocker arms are dispensed with and the push rods act directly upon the valves.

Some engines are provided with an auxiliary or relief exhaust. This consists simply of a port, which, at the will of the operator, is uncovered at the end of the outward stroke of the piston, thus allowing part of the products of combustion to pass out immediately into the exhaust pipes. The hottest gases are thus removed from the vicinity of the exhaust valve, and danger of corroding and sticking the valve stem is thus lessened. The use of this feature is advisable at heavy, continuous loads, and in very hot weather.

#### PISTON

The piston is of the trunk type commonly used on single-acting engines. The explosion acts on one end of the piston, the other being open to receive the connecting rod. The piston is of cast iron turned to size. In order to allow free movement it is made slightly smaller than the bore of the cylinder, usually one thousandth of an inch less for each inch in diameter of the latter. In order to retain the compression the piston is encircled by expanding rings set in grooves machined out of the piston. There are usually three or four rings at the head of the piston and sometimes one ring near the open end. This latter ring is sometimes used for the purpose of distributing the lubricating oil and sometimes its main purpose is to assist in preventing the loss of compression. In other cases it is to prevent the wearing of the cylinder wall

to form a shoulder at the end of the piston stroke. In the latter case both this ring and the one at the other end of the piston are allowed to travel half their width beyond a counterbore, or enlargement of the cylinder diameter. In the absence of some such provision the end of the piston wears the cylinder until a shoulder is formed, and if at any time the length of the connecting rod is even slightly increased, knocking in the cylinder will result. Where splash lubrication is used, this ring wipes the excess oil back into the crankcase. The cylinder rings are of cast iron and machined to size. After being ground to a size larger than the cylinder, a segment is cut out. The ring is then compressed into place so that its tension causes it to fit snugly against the cylinder wall.

#### CONNECTING ROD

About midway of the piston there are interior enlargements or bosses for supporting the wristpin, to which the connecting rod is attached. The wristpin itself is usually hollow and provided with holes for lubricating its bearing with the oil collected from the cylinder wall. The connecting rod, which transmits the power from the piston to the crankshaft, is usually of I-section, drop-forged steel, as on the best locomotive and marine steam engines. There are numerous devices for attaching the connecting rod to the crankpin, it being frequently necessary to withdraw the piston and connecting rod to examine the former. The same devices serve to provide adjustment for wear. The most common and probably the most satisfactory method is a removable cap attached to the connecting rod by bolts on either side of the crankpin. Both ends of the connecting rod are commonly lined with an anti-friction material, most of which goes under the name of Babbitt-metal.

#### CRANKSHAFT

The crankshaft must be proportioned to meet the strain which is placed upon it, and must be well supported by wide

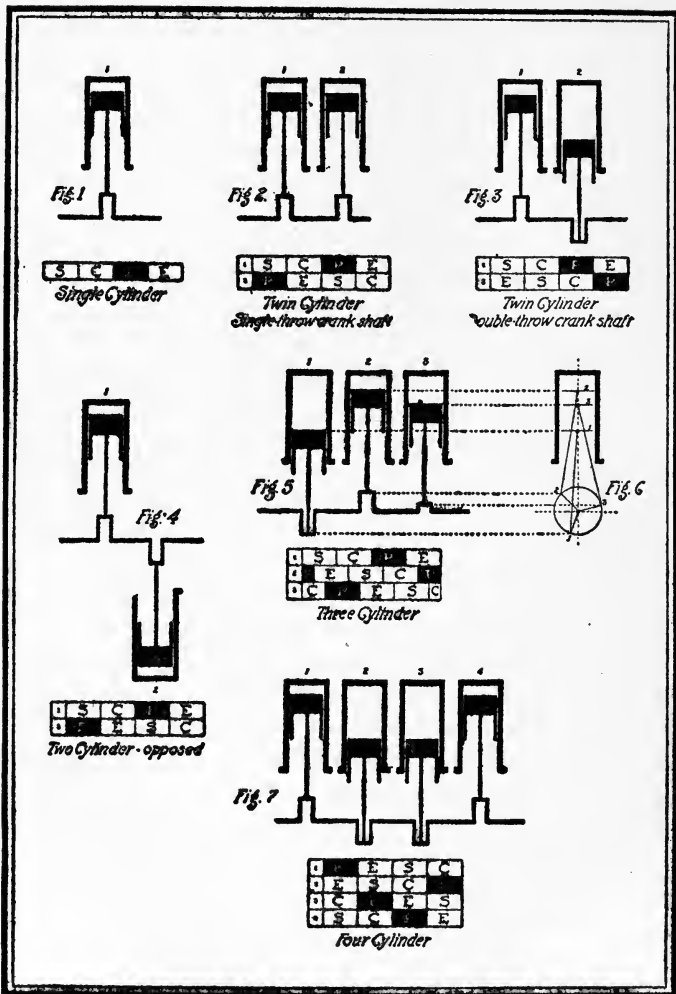

Types of crankshaft



bearings. The variation in number and arrangement of cylinders requires material differences in the crankshaft. The arrangement of the crankpins with respect to one another has an important influence upon the sequence of the strokes of the engine, as shown by the accompanying diagrams. It will be noted that the power strokes of the four-cylinder engine are the most evenly balanced, and those of the three-cylinder next. In the two-cylinder engines the explosion balance may be obtained by the opposed type, or else the twin-cylinder type in which the pistons move together, both crankpins being on one side of the crankshaft. The opposed engine with pistons working opposite each other gives also a rotative balance, which in the twin-cylinder engine can be had only by adding counter weights to the crankshaft or flywheel. In the twin-cylinder engines which have the cranks on opposite sides of the centre of the shaft, the pistons travel opposite each other, thus obtaining rotative balance at the expense of explosion balance. In the single-cylinder engine there can be no explosion balance, and rotative balance is secured by counter weights, which should be as close to the centre of the crankshaft as possible in order to balance properly at all speeds. The four-cylinder engine, which gives the most continuous succession of power strokes, is, of course, much more complicated than one with fewer cylinders. In the opposed engine the necessity of operating the valves at such a distance from each other is one disadvantage, and the distance of the intake valves from the carbureter is another, which makes for higher fuel consumption. The opposed engine is used on only a few tractors.

#### FLYWHEEL

The flywheel of the gas engine is for the purpose of storing up part of the power developed by one stroke of the piston in order to insure the other three events of the cycle. In many tractors a single flywheel is used, the belt pulley being mounted

upon the opposite end of the shaft. In a few cases the two flywheels are used, the pulley being attached to one of these. The permissible rim speed of a cast-iron flywheel is between 5000 and 6000 feet per minute, hence small flywheels are the practice on high speed engines. With the power strokes coming closer together as in a four-cylinder, high speed engine, a large flywheel is not so essential. The weight of the flywheel should be as near as possible in order to give the greatest possible momentum. As the flywheel is heavy, sometimes weighing 1300 pounds, it is necessary that it be put on the shaft in such a way as to remain there indefinitely, and yet be easily removable. For this reason, and for ease in casting, it is now customary to split the hub of the flywheel. It is locked by means of a key seated in both the shaft and hub, after which it is tightened on by two bolts through the hub on either side of the shaft.

#### CRANKCASE

In stationary engines it is customary to provide a heavy base, either cast or bolted to the crankcase. In tractors this base is discarded, and the frame takes its place. The crankcase, however, is retained to provide a foundation for the crankshaft, camshaft, and cylinders. The protection of the moving parts inside the crankcase requires not only the exclusion of dust but that some form of lubrication be provided. The splash lubrication commonly used necessitates a tight crankcase, which in turn is frequently difficult of access. To combine the two extremes of accessibility and protection is a difficult problem for the designer, yet in some cases it is possible to expose the entire internal mechanism of the tractor by the removal of a tight-fitting cover.

#### LUBRICATION

For the lubrication of the gas engine any one or all of three systems may be used — namely, gravity, force-feed, or splash.

In the gravity system small sight-feed oil cups are placed at convenient points, and the amount of oil delivered is governed by the size of the opening from the cups. On a small horizontal engine this method is quite satisfactory, more so than on upright engines unless oil cups are placed on either side of the vertical cylinder. Owing to the severe conditions which the tractor must meet, a more positive system is necessitated. The force-feed system consists of a mechanically operated lubricator with a number of separate pumps capable of delivering oil against considerable pressure. This is commonly used to supply oil to the cylinder and to the camshaft and crankshaft bearings. The drip from these sources is usually collected in the crankcase where a considerable quantity is allowed to accumulate. At a certain level this oil will be dipped by the rapidly revolving crankshaft, and a spray will be sent into the cylinder and every part of the crankcase. This is called the splash system, and on some engines it is depended entirely upon for lubricating the cylinder. However, the heat will evaporate some of the lighter parts of the oil and in the course of time it becomes heavy and dirty. The splash, therefore, is used most successfully in connection with a force-feed lubricator, which is constantly bringing fresh oil, while an overflow drains off a certain quantity from the crankcase to the gears below.

The lubrication of bearings on gas tractors presents no new problems, but the lubrication of the cylinder is vastly different from that of the steam cylinder. In the latter the effort is made to procure an oil which will emulsify and cling as a thin film to the cylinder wall, resisting the high temperature for a considerable length of time. In the gas engine the oil must do its work in the face of so high a temperature as to make it impossible for the oil not to be broken up. As a result, part of any oil will be burned, and the best gas engine oil is one that, after performing its duty, will mix with the charge and be burned completely.

In both the steam and the gas engine cylinder, there is danger of feeding too much oil and creating a heavy deposit. This will act as a collector of the scale-forming material which comes over in the priming of the steam boiler, and the grit which comes through the air intake pipe on the gas engine. The paste thus formed is ideally adapted to cutting and scoring the cylinder, just as emery paste will remain longer between two metal surfaces than dry emery powder. As one of the leading lubrication experts, Mr. F. M. Williamson, put it: "You see the danger of assuming that if a little oil is good, more is better." A number of special gas engine oils of excellent quality are put out by the oil companies, and in justice to the tractor a good brand should be used, and used judiciously.

#### COOLING SYSTEMS

The exhaust will carry from 35 to 40 per cent. of the total heat generated in the gas engine. Since only from four to five per cent. will be consumed in friction of the piston and bearings, and, as a rule, not more than 20 to 25 per cent. will be delivered as useful work, it follows that the cooling system must remove at least one third of the heat. The cylinder is cooled in order to make it possible for the operator to work in comfort; to prevent damage to the cylinder and valves, since cast iron melts at a lower temperature than is frequently realized at the moment of explosion; to prevent burning the lubricating oil before it completes its work; to avoid igniting the incoming charge by the heat of the cylinder walls; and in order to allow a higher compression pressure, which in turn gives a greater amount of power for a given size of cylinder and a given quantity of fuel.

A number of systems which are feasible in stationary work are unsuitable for tractors. In the case of the self-contained portable motor, the quantity of cooling medium which can be transported is necessarily limited and the unusually rough,

dirty nature of the work prohibits the use of open water tanks. Owing to the size of the motors employed, the air-cooled traction engine is practically out of the question, and the cooling medium is usually either water or oil. The water should be as pure as possible, owing to the fact that mineral salts in solution may be precipitated by heat at temperatures even below the boiling point. The scale thus formed tends to impede the circulation, and if deposited on the cylinder wall of the water jacket will decrease its conducting capacity and tend to produce overheating in the cylinder. The oil used for cooling is of rather heavy mixture with a high fire test. Its boiling point is considerably higher than that of water, hence it does not evaporate and require frequent replacement. It is not so rapid a conductor of heat, yet on the other hand it has the advantage of not freezing or depositing scale. One manufacturer recommends a mixture of kerosene and water to prevent corrosion and scale. Others suggest the use in severe weather of some anti-freezing compound, such as a solution of calcium chloride (specific gravity 1.2) or of equal parts of glycerine and water, or a mixture of alcohol and water.

In engines of ordinary design the cooling medium should not be heated above the boiling point, nor cooled so low as to absorb heat from the gases before they have had time to act. In practice the temperature ranges from 160 to 180 degrees F., varying considerably with the movement of the tractor with or against the wind.

The medium is commonly circulated by either a centrifugal or a plunger pump, though, in rare instances, it circulates entirely by the difference in specific gravity between the liquid in the tank and the hotter liquid in the cylinder jacket. One simple, popular and effective system of removing surplus heat from the water, which is used in this case, is that of an open evaporating radiator. The water is sprayed over a screen, along which it passes back to the tank, the partial evaporation absorbing enough heat to cool the remainder rapidly. One

great objection to this system is the large quantity of water used and the necessity for frequent re-filling of the tank. Another arises from the fact that in alkali districts the rapid evaporation leaves behind a solution of increasing density from which scale-forming material will be deposited. Unless the screen is protected, dust from the atmosphere will add further difficulties. In some enclosed coolers the spray of water, or oil, is met by a current of air, generated by a fan. The liquid being finely divided, a large area is exposed to the air, hence cooling occurs quickly.

In the closed type of radiator the air is separated from the liquid medium by metal walls. On some small tractors are found tubular or honeycomb radiators in connection with fans, similar to the system used on most automobiles. Ordinarily, however, the radiating sections are not so delicate, and a larger quantity of liquid is necessary in order to expose sufficient area to the draft. In several cases the fan is dispensed with, and the process simplified. The cooling of the exhaust produces a partial vacuum and thus induces a strong draft upward, which cools the liquid satisfactorily. In one case the cooling arrangement is simply a huge tank, the water being circulated by a pump, and the cooling being effected by the evaporation of the water from the surface.

A very effective method of cooling which may be used in connection with some of the foregoing is that of using water vapor with the mixture of the fuel and air to cool the cylinder. In one tractor the steam which is formed in the radiator is piped to the carbureter and inhaled with the fuel. In other cases water is taken with the fuel through the carbureter and vaporized in the cylinder. The amount of water is, of course, slight, increasing automatically with the increase of heat generated at the higher loads, or being cut out entirely at the will of the operator. The latent heat of water is so high that the evaporation of a very small quantity will prevent preignition and the steam will have in addition a cleansing effect upon

the cylinder. By this method the water cools the hottest projecting points first, the exact reverse being true when cooling is done from the outside. This means is particularly advantageous with engines using the heavier fuels, as it allows the use of higher compression, and thus materially increases the power of the oil engine. It also produces a smoother and quieter running engine, by retarding the spread of the flame cap throughout the mixture. Instead of a sharp initial blow, followed by a rapid decline in pressure as the gases expand and the cooling medium takes effect, the explosion pressure is not only less violent but the piston receives a sustained push after the manner of a steam engine. The water is usually injected only at half load or above.

#### FRAME

No part of the traction mechanism or foundation can be neglected without impairing the efficiency of the tractor. The frame must be strong enough and large enough to support the weight of the engine, radiator, and operator's platform, and rigid enough to furnish a stable bed for the engine. The work is necessarily rough, and if in addition there is constant vibration of the tractor frame, a smooth-running, durable motor cannot be expected. For this reason the frames are usually of heavy, continuous, steel I-beams or channels, extending from front to rear. These are usually tied together crosswise with other members of ample dimension. Since the frame, if heavy enough, will never need replacing, many builders are riveting it throughout into one solid block. The frame should support the brackets for the important shafts, including the rear axle. In order to provide for all this without excessive weight in castings a sub-frame, also of steel, is added often to the main frame. In some cases the two are combined in one trussed frame of bridge construction.

## TRANSMISSION

In transmitting power from the crankshaft to the drive-wheel, we find almost our widest variation among tractors, and the comparative efficiency of the various types of transmission has never been even partially determined by accurate competitive tests. This is unfortunate, for tractive efficiency is one of the prime essentials of a plowing tractor. It is by no means the only essential, for great tractive efficiency can be obtained by any designer who is willing to sacrifice other features of equal importance. All other things being equal, however, it is obvious that the most desirable tractor is one which will consume the least power in moving its own weight and overcoming the friction of its transmission. The crankshaft makes many more revolutions than could be allowed for the drive-wheel, consequently the speed of rotation must be reduced and the power at the same time delivered to the drive-wheel at some little distance from the engine. The transmission systems may be divided into friction, chain and gear drive, and the latter again into systems employing all spur gear, or part bevel and part spur gear. Combinations of all systems are found. The size and strength of the various parts of the transmission must gradually increase as their speed is reduced, owing to the greater strain upon each link or tooth.

## FRICTION CLUTCH

It is evident that there must be a friction device which will allow the load to be applied gradually. Otherwise, especially in plowing, the initial effort of starting the load would require much greater power and strength than ordinary requirements would justify. The friction clutches which are used represent practically every type found on automobiles and steam engines. Probably the most common is the internal expanding clutch, commonly found on steam tractors. This is equipped with two or more friction shoes, which when thrown in are locked,



thus avoiding any tension upon the clutch lever. The external type, gripping the outside circumference of a wheel, is also used, as well as planes gripping both sides of a revolving disk. In place of an internal shoe, an expanding ring is employed by some, also a cone, which is forced into a similarly shaped ring. Several disks tightly pressed together, as in the multiple disk clutch of an automobile, are also employed.

#### BAND-WHEEL

Without notable exception, all tractors are provided with a band-wheel, or belt-pulley for transmitting power in stationary work. This is most often placed upon one end of the crankshaft, where it acts as a second flywheel, but in a number of high-speed engines it is placed upon a countershaft which revolves at a lower speed. As in steam engines, the band-wheel is frequently made part of the transmission system, a single clutch driving the band-wheel, which may drive either the belt or traction gearing. Suitable provision is made to throw the traction parts out of gear when work is to be done by the belt.

#### GEAR DRIVE

Where the crankshaft lies crosswise of the frame, the power is usually taken directly to the drive-wheels by a train of spur gears — *i. e.*, cylinders with parallel teeth cut or cast on the circumference. Chains or friction wheels may replace part of these gears. A large gear on the countershaft receives power from the crankshaft and transmits it through a smaller gear on the same shaft to the master gear, which drives the traction wheel. When cylinders are mounted lengthwise of the frame, it is necessary to change the direction of rotation to one which will drive the tractor forward. This is accomplished by means of bevel gears in addition to the ordinary set.

The gears may be either of steel or semi-steel, the latter being a mixture of steel and cast iron. The crankshaft pinion and the gear it engages are usually of cast steel with machine-

cut teeth. The shafting must be made of the highest quality of steel and carefully machined to size. If a sliding gear transmission is used it is the practice of the leading designers to cut from two to four keys out of the solid steel shaft for the gears to slide upon. This is an extremely expensive construction, but, since the keys are a part of the shaft itself, it overcomes stripping or damage to gears from loose keys. The sliding gear and those which it engages, usually have the teeth beveled on the sides so as to slide into mesh more easily.

#### CHAIN DRIVE

The chain drive has the advantage of flexibility and may be combined to good advantage with the spring-mounted frame. A well-designed chain and sprocket form an efficient transmission, but the number of joints renders it subject to greater wear than gears, and only a few tractors employ this method. A pinion and master gear are sometimes used in place of the final chain for driving the wheel or axle. In one three-cylinder tractor both bevel and spur gears are used in connection with a chain drive from countershaft to master sprocket.

#### FRICTION DRIVE

Few friction-drive constructions have been attempted, and few of these survive, except on tractors designed for lighter work than plowing. In one of the most successful, fibre-covered disks take the power from the inside rims of both flywheels for the forward speed and from the hub for the reverse. This construction is simple and easily managed, and it eliminates the use of a clutch, but it is doubtful if the disks can be made durable enough for heavy plowing service. The experience of automobile manufacturers has been that the best friction material is too short-lived, even for such light work.

#### REVERSE

Easy manœuvring requires some provision for reversing the direction of movement. In the steam engine this is accomplished

simply by reversing the engine itself. The gas engine, with very few exceptions, is made to run only in one direction, hence the reversing must be done by other means. The reversing mechanism which may be used is limited to some extent by the arrangement of the cylinder.

On tractors which have the crankshaft crosswise to the frame, reversing may be accomplished by the use of a sliding gear and a separate idler shaft carrying two pinions. When the sliding gear is in mesh with the differential gear the tractor moves forward. When it engages the larger of the two pinions on the idler shaft, the other of which constantly engages the differential, the tractor is reversed. Some tractors are equipped with two or more forward speeds, and one on the reverse. One speed-changing system involves a combination of gears and sliding clutches. This is known as the selective type of transmission, since any speed or the reverse may be selected without the use of a separate idler shaft. Many tractors are provided, however, with two large gears on the countershaft, three on an idler shaft, and two on the sliding-gear shaft. This gives two forward speeds and the reverse. Separate trains of gears on opposite sides of the tractor are used in certain cases to obtain the forward and reverse motions, clutches being provided for gripping the two sets independently. In some small tractors the friction pulley is retained for the reverse motion. An eccentric shaft brings the pulley into contact with a similar pulley on the crankshaft, a toothed gear attached to the driven pulley driving the large gear on the countershaft.

The planetary reverse resembles somewhat a spur gear differential. A "sun" gear, moving with the crankshaft, is in mesh with small pinions, and these in turn with an internal gear which is part of the belt pulley. The pinions are held on a spider connected to a large disk by a long hub which is loose on the crankshaft. The reversing process consists in holding the disk stationary by a pair of clutch-blocks. This holds the axles of the small pinions stationary, and since the

sun gear is in rotation forward, the internal gear is driven backward through these pinions. For the forward motion the entire system moves as a unit. In this system a single lever controls the entire mechanism for forward and reverse travel. The pinion which drives the traction gears fits loosely on the long hub of the reversing disk, and is attached to the belt pulley by a key. This key moves radially on the back of the pulley and enters a slot in a flange cast on the "sun" gear. This pin is operated by a small lever extending through to the outer face of the pulley, so that the pulley can be disengaged from the spur flange pinion at the will of the operator and used for belt driving.

#### DIFFERENTIAL

The differential may be mounted on either the countershaft or the real axle. In the former case, which is the rule on the most powerful tractors, power is applied to either wheel by means of a master gear, which is braced to the rim. The spokes then serve only to support the weight of the tractor. The axle often remains stationary, or "dead," both wheels turning upon it. In gas tractors the axle is usually continuous, though short, or stub, axles are occasionally employed. When the differential is located on the real axle, power is applied through the axle, hub, and spokes, which adds a twisting strain to the load upon the latter. The wheels are necessarily independent, hence a sleeve revolving upon the axle is used to drive the wheel which is loose on the axle. In many cases the differential may be locked, so that if one wheel gets into soft ground the other may propel the tractor out of the difficulty.

#### BRAKE

Control of the tractor on sharp inclines and in other emergencies requires the installation of a powerful, quick-acting brake. Where a band-wheel clutch is used in the transmission, a simple form of brake is a shoe on the face of the band-wheel.

This stops the traction gearing when the clutch is thrown off, the two actions being performed in concert. A band-brake, operating on a drum on the differential shaft or the rear axle, is another successful device.

#### TRACTION WHEELS

The high and fairly narrow wheel, 18 to 30 inches wide and 70 to 96 inches in diameter, and of sufficient strength to endure ordinary service, is apparently the most popular for gas tractors, judging from recent design. Extension rims of 10 or 12 inches are provided in most cases for use in soft ground. The wheels are usually of the built-up construction. This consists of a steel tire plate to which the cleats are attached; round or flat steel spokes; and a cast-iron hub into which the spokes are either riveted, cast or screwed. The spokes are most often arranged radially, are occasionally on a tangent, and even rarely are continuous, extending star-fashion, clear across the wheel on opposite sides of the hub. The spokes may be staggered — *i. e.*, from the outside of the spokes are frequently upset to "T" shape so that two rivets may pass through the head of the spoke and the tire. Flat spokes are sometimes bent to fit the tire and then riveted, this being a weaker construction. In some cases the end of the spoke is flattened out like a paddle, and this riveted to the vertical flange of an angle or channel iron which has been put on to reinforce the tire. The round spokes sometimes extend through the tire from the outside and are screwed into the hub. This holds the tire to, instead of away from the hub, making what is known as a tension spoke in contrast to the compression spoke usually employed.

The best type of grouser is a very unsettled problem. The most common form is a V-section made of cast or malleable iron. These may be attached parallel with the axle, or at an angle in order to facilitate self-cleaning. Grouters set at an

angle are usually placed so that the rear end of one comes opposite the front of another to make the circumference more continuous and reduce jolting. Some firms use pressed steel plates which, when attached, form a continuous succession of corrugations clear around the wheel. This is claimed to pass over soft ground without tearing up the surface and still prove efficient in gripping hard roads and wild sod. One firm has a peculiar crow's-foot grouter, while several use sharp spikes, either conical or pyramidal in shape. The English tractors sold in this country and Canada are not ordinarily provided with such sharp cleats, using instead flat strips of steel put on at an angle with narrow spaces between. They prove efficient on good roads rather than in field work, and separate mud lugs are provided for emergencies.

#### STEERING WHEELS

The majority of tractors have two steering wheels in front, though there is a respectable number of three-wheeled types. The three-wheeled tractor will turn in a somewhat shorter radius, but the four-wheeler with the weight carried on a ball and socket joint has practically a three-point support and is less affected by minor irregularities in the ground surface. The front wheels are usually built up, with a raised collar shrunk on the tire to prevent lateral slippage. A few wheels are made, however, with steel spokes cast into an iron hub and rim.

#### STEERING MECHANISM

The steering mechanism usually operates on the front wheels, though some attempt has been made to guide through the drivers, and on one light traction cultivator a single steering wheel is placed in the rear. In the majority of tractors a chain is attached near either end of the front axle, after being wrapped several times around a horizontal shaft, which is rotated by a worm gear and steering wheel. The entire axle

is rotated about a pedestal which supports the frame. In another type the axle remains stationary. The wheels turn about short axes, being mounted on independent knuckles, as in an automobile. A single wheel in front is sometimes directed by means of a spur pinion and a segment of spur gear. The upright shaft carrying this pinion may be operated from the platform through a steering wheel and cable, or a line shaft with a bevel or spiral gear may take the place of the cable. In one friction-drive tractor a pair of friction disks are connected by a horizontal shaft and bevel pinions to an upright shaft which in turn acts upon the ordinary chain and drum. By bringing one or the other disk in contact with the rim of the adjacent flywheel, the power of the engine can be used for steering. In another case the steering is done almost automatically in plowing by a long triangular frame which extends forward of the front axle, carrying at the end of the frame a wheel which hugs the wall of the previous furrow. Cables extending from the hand steering wheel to the wheel on the triangular frame enable one to steer by hand for turning and for other kinds of work.

#### HITCH

The drawbar to which the plows are attached is usually supported by a strong truss riveted to the tractor frame. On most plowing tractors a plow beam, made of two pieces of angle or flat steel, extends across the rear, being punched at intervals to allow the insertion of a pin and clevis. In some tractors this crossbar is merely to hold in place a swinging drawbar which is attached at a point near or in advance of the rear axle. This places the load nearer the center of the engine, and makes turning much easier. Frequently the tractor is equipped with an eyebolt and spring to absorb the jar on starting. Since a variation in the point of hitch may either increase or decrease the draft, it has been found advisable on some tractors to provide some means of adjusting the height

of hitch. This is done either by a vertically swinging rod or a series of holes in an upright beam.

#### SPECIAL TYPES

For overcoming the disadvantage of the tractor in extremely soft ground, no device appears to be more successful than the substitution of a caterpillar tread for the ordinary round traction wheel. Although the idea is several generations old, a tractor with this type of transmission has only recently been put on the market in large numbers. The weight of the tractor is supported on steel rollers, which run upon the inside of a continuous belt made of pressed steel plates. The belt is driven by a sprocket and chain, so that the tractor virtually lays its own track and picks it up again. A single wheel in front supports part of the weight of the tractor at rest. Under working conditions, practically all the weight of the tractor is borne on the rear, where it is distributed over such an area as to reduce it to seven or eight pounds per square inch. Steering is done by driving the caterpillar webs independently of each other, a slight amount of flexibility in the joints allowing them to turn sidewise. The power is transmitted by a line shaft connected to the crankshaft by a multiple disk clutch. The connection is semi-flexible so that the bevel pinion on the end of the shaft may be shifted to engage a smaller driving gear for a change of speed. Two bevel driving gears are connected to the countershaft by independent friction clutches in order to accomplish the forward and reverse motions. This tractor will work in many sections where the round-wheeled tractor is impracticable, but the natural wear on the many joints and the difficulty in turning the outfit are disadvantages which accompany high tractive efficiency. Power in this tractor is supplied by a high-speed four-cylinder four-cycle verticle engine set lengthwise of the frame.

A light tractor on the order of a motor truck, but adapted



especially to farm work, has been well received by many farmers having a greater variety of work than those in the grain belt. The tractor is equipped with a pulley for driving stationary machinery, and a drawbar for pulling plows. It has also a hauling body which will carry a load of three or four tons. The weight of the tractor is quite evenly distributed over the four wheels, hence for plowing it is more efficient when carrying some load over the drivers. The tractor is spring-mounted and adapted to speeds of from two to fifteen miles per hour. Wooden plugs, set in round sockets on the circumference of the wheels, take the place of rubber tires in adapting the tractor to hard roads. An extension rim is provided with mud lugs which automatically grip the soil when the wheels sink to a certain depth, and by a hand lever on each driver a series of sharp spikes may be thrust out beyond the periphery of the wheel and locked in position.

The field of cultivating intertilled crops, which has long been regarded as the exclusive province of the farm horse, has been invaded by a tractor designed essentially for cultivating. This is a light outfit with large drivers carrying the weight of the engine and frame, and a small steering wheel in the rear. The cultivator is built in sizes for taking care of one and two rows respectively, but has been sold as yet in a very limited way.

Gas tractors have been adapted to nearly as many different purposes as steam tractors. One type is built low for orchard cultivation. Others may be converted into road rollers. Mention has been made in a previous chapter of the long list of gas-propelled farm machines, out of which may come some universal type. Perhaps the latest adaptation is the use of a six-cylinder tractor for pulling a combined harvester. A belt extends from the flywheel of the engine to an electric generator mounted on the harvester, to furnish power for driving the cutting, threshing, cleaning, and elevating mechanisms of which the harvester is composed.

## XI

### EFFICIENCY OF GAS TRACTORS

**G**AS tractors range in size from 12 to 110 b.h.p., and from two and one half to fifteen tons in weight. The brake horsepower ratings are usually placed closer to the maximum load than for steam engines. This is logical, since the engines should be rated at the load which they will carry safely and economically. It is customary to provide 10 to 20 per cent. of power over the rating in order to protect the machine from overloading and the customer from disappointment. The gas tractors are fairly well divided by manufacturers into three classes. The first consists of tractors of from 18 to 30 b.h.p., capable of handling three or four plows in ordinary sod-breaking. The second is provided with from 40 to 50 b.h.p., handling from five to seven plows in heavy work. The largest class ranges from 60 to 75 b.h.p., with the ability to pull from eight to ten plows under the same conditions. A few have been made even larger than these, but are not as yet sold so extensively as either the smaller gas tractors or steam engines of large size. They will pull ten or twelve breaking plows, comparing in power with steam engines of 30 to 32 h. p., nominal rating. Recently there have also been put on the market a number of small outfits weighing from two to four tons, and having as low as 12 b.h.p.

The indicated horsepower of gas tractors is seldom given among the manufacturer's specifications. The brake horsepower at full load is usually from 75 to 85 per cent. of the

indicated horsepower, though often lower. In the Winnipeg motor contests few gas tractors have equalled their rated power in brake tests. In 1910 the class as a whole averaged 86.5 per cent. of the brake rating on a maximum test, and 80.9 per cent. on an economy test. The actual drawbar or tractive power of tractors cannot so easily be compared on account of lack of uniformity in rating. The sales rating is sometimes based on brake and sometimes on tractive horsepower, while in many cases it bears little relation to either. As a general rule the tractive ratings are about one half the brake rating.

The tractive efficiency of the average round-wheel gas tractor on good footing ranges from 50 to 60 per cent., dropping sometimes to as low as 30 per cent. and occasionally reaching 70 per cent. In the trials at Winnipeg in 1909 seven single-cylinder gasoline tractors, using comparatively low, wide wheels, weighed 299 pounds per inch in width of driver and 535 pounds per brake-horsepower developed in an economy test. In plowing, they delivered 61.4 per cent. of the brake-horsepower at the drawbar and in hauling, 50.8 per cent. assuming, of course, that a comparison of separate brake and traction tests is reliable. Basing the tractive efficiency on the fuel consumed per unit of work in the various tests, it fell to 44.1 per cent. in plowing and 35.5 per cent. in hauling. Ordinarily, of course, the tractive efficiency in hauling would be the greater, as road surfaces would be more solid than that of plowing fields. The hauling course for the tests afforded poor footing, as has been stated already.

In the same tests, several multiple-cylinder gas tractors, equipped with high, rather narrow wheels, weighed 407 pounds gross per inch in width of driver, and 416 pounds per economy brake-horsepower. They were less affected by the adverse conditions in the hauling tests, both horsepower and fuel consumption indicating a tractive efficiency of a trifle over 50 per cent. The actual figures were 53.1 per cent. in

plowing and 49.9 per cent. in hauling, when based on a comparison of horsepower developed; and 53.8 per cent. and 53.3 per cent., respectively, when based on a comparison of fuel consumption. With high wheels, tractors are able to negotiate extreme ground conditions with less loss in efficiency than the low-wheel types, especially if accompanied by light weight.

In the motor contest of 1910, with an average of 70 per cent. of the total weight resting upon the drivers, seven gas tractors exerted in plowing an average drawbar pull of 25 per cent. of their total weight or 35 per cent. of the weight on the drivers. In 1909 the gas tractors at Winnipeg averaged about 17 per cent. of their total weight in drawbar pull in two-hour hauling tests over a very uneven course, and about 24 per cent. in plowing firm level sod ground. As a mean of the two traction tests they developed one drawbar-horsepower for 922 pounds of total weight, or much more than could be reasonably expected of horses.

In private tests made on a good stone road, one large gas tractor, drawn at its own rated speed of travel, required one sixth its rated brake-horsepower to move it. At the rate of two and one half miles an hour on an earth road, approximately 25 per cent. of its maximum brake-horsepower was consumed in moving. This shows clearly the loss due to moving the weight of the tractor with merely its traction gearing in mesh and motor plant idle. Data on the loss in tractive efficiency due to grades, will be found elsewhere in this book.

The gas tractor has small overload capacity, if it is run ordinarily at its most economical load. In the last motor contest, eight tractors out of eleven were able to show less than 7 per cent. increase in power between the economy and maximum brake test. The engines were not necessarily run at the most economical or the maximum points in either case, and in fact, two showed a decrease in fuel consumption on developing a

greater horsepower in the maximum test. Even with a slight increase in load, the majority of tractors consumed from 13 to 35 per cent. more fuel per unit of work. The present types of tractor are considerably less flexible than the steam engine, and infinitely less so than the horse.

From the various motor contests, we obtain the following table, which shows the amount of fuel consumed by gasoline engines in various classes of work. The fuel consumption in the brake tests increases with the number of cylinders, as is to be expected.

GASOLINE CONSUMED PER DELIVERED HORSEPOWER PER HOUR

1 CYLINDER			2 CYLINDERS		3 & 4 CYLINDERS	
Test	No. Tests	Lb. Fuel	No. Tests	Lb. Fuel	No. Tests	Lb. Fuel
Brake.....	11	0.567	4	0.836	12	0.965
Plowing.....	6	1.273	4	2.076	9	1.778
Hauling.....	5	1.536	1	3.97	6	1.88

The gasoline used was of 70 specific, 64 Baumé gravity. The average consumption for 27 brake tests was 0.747 pounds, or a trifle over a pint per horsepower hour. Nineteen brake tests averaged 1.67 lbs. and 12 hauling tests 1.91 lbs. per drawbar-horsepower hour. These averages are not strictly comparable with each other, owing to the fact that some tractors did not complete all of the tests and the data represent results in two succeeding years. No kerosene tractor has as yet achieved the thermal efficiency of the best gasoline tractors, but in all but the most remote districts the wide and growing disparity in fuel costs gives the former a marked commercial advantage.

Gas tractors have a wide range in speed, but for plowing few travel over 1.75 to 2.25 miles per hour, and the majority

have plowing speeds of about 2 miles per hour. Owing to the fact that the majority carry fuel and water for a continuous run of ten or twelve hours, they are able to deliver from 85 to 90 per cent. of their rated plowing speed in net furrow travel. For hilly country, tractors are geared for speeds of from 1 to 3 miles per hour. For Western conditions, even the high speeds are seldom above the latter figure.

The cost of operating a tractor hinges on so many varying factors that dependable averages are scarcely to be had. Two men will handle almost any gas tractor and its load of plows. These two men and their board will cost from \$6.00 to \$7.00 per day of actual work. A well designed and well built tractor should give 1000 days of service, working 10 hours per day. Interest rates range from 6 to 8 per cent. in the Northwest. Repairs should not exceed 10 cents per acre at the outside, and a reasonable figure is 2 per cent. annually of the first cost. Gasoline costs from 10 to 25 cents per United States gallon in different localities, and from 15 to 30 cents per imperial gallon in Canada. Kerosene costs from 3 to 18 cents in United States and from 11 to 25 cents in Canada. Distillate can be had at from 1 to 4 cents below the cost of kerosene in various localities. The consumption of kerosene or distillate, taking the leading kerosene and gasoline engines as a whole, will probably be slightly in excess of the consumption of gasoline, both in volume and weight, but the fuel costs per acre will be much less, ranging from 10 to 100 per cent. or even more in districts close to refineries. Lubricating oil will cost from 50 cents to \$1.00 per day in plowing, depending upon the size of the tractor and severity of the work.

The following estimates of the comparative cost of production of wheat on old ground in eastern North Dakota are comparable for that section. However, the character of the soil, the distance over which supplies and products must be hauled, the type of machine and the personality of the operator are all influential factors.

## COST OF WHEAT PRODUCTION PER ACRE

	WITH HORSES	WITH TRACTORS
Land rental,	\$2.00	\$2.00
Plowing,	1.35	.76
Seed,	1.13	1.13
Pulverizing and seeding,	.63	.17
Twine and cutting,	.75	.39
Shocking,	.22	.22
Threshing,	.65	.65
Machinery costs,	.62	.67
Hauling,	1.00	.26
Incidentals,	.30	.30
	<u>\$8.65</u>	<u>\$6.55</u>

In the above summary of costs the overhead charges on the prime mover are included in the various costs of operation. Machinery costs for the tractor are a trifle higher, because of the added investment in suitable plows.

The manager of a noted Dakota bonanza farm puts his cost of raising wheat with horses at \$8.45, a figure which is lower than the average recently reported for that section by the *United States Crop Reporter*. A traction farmer only recently produced a 2000-acre crop of flax in the same section for \$6.56 per acre, allowing for all overhead charges on engine, machinery and land. Roughly speaking, the gas tractor cuts 10 cents per bushel from the cost of producing an acre of twenty-bushel wheat.

## XII

### FUEL FOR GAS TRACTORS

**T**HE internal-combustion, or gas, tractor is of the greatest importance in the future development of power plowing. We need, therefore, to give considerable attention to the question of fuel for this type of motor, since the ultimate success of mechanical power on the farm will depend upon the certainty of an adequate supply of suitable fuel. It is obvious that certain fuels, which are so well adapted to stationary practice, that in some localities they predetermine the type of gas engine, may be utterly impracticable for use in the gas tractor. We shall discuss in detail, then, only those which may be used economically in plowing.

By their very nature and source, natural, blast furnace, and city coal and water gases are not suitable for use in portable motors. However, Ocock suggests that the farm tractor's fuel will ultimately come from gas, which will be made directly from waste materials and compressed in tanks. This would allow the temperate zones to use the power of tropical vegetation, saving the loss of energy encountered in converting raw vegetable materials into alcohol, and alcohol again into gas, but would entail the danger and expense of handling high-pressure tanks. Suction gas producers, making gas directly by drawing steam and air over an incandescent bed of anthracite coal, have been mounted on wheels with great economy of fuel as a result, but have proved too large and heavy to be considered seriously for traction work. Benzol, a volatile



distillate of coal used extensively in Europe, has not yet been produced in America on a large scale. Up to the present time engines capable of burning heavy crude petroleum successfully have also been too heavy to mount in tractors. Our discussion then will be limited to alcohol and the petroleum distillates, since these are at present the most promising from all standpoints.

Alcohol is the fuel of the distant future. While tests have shown that this fuel has many advantages over gasoline, such as safety, freedom from carbonization, less offensive exhaust, ease in mixing, and greater power from the same size of engine, the cost at the present time puts it out of the question for general use. Alcohol costs from three to five times as much as gasoline. Ordinarily it contains only from 10,200 to 12,900 B.t.u. per pound, according to its purity, as compared with about 20,000 for gasoline or kerosene. According to prolonged scientific tests of an engine designed for gasoline, reported in *Farmers' Bulletin 277*, it required 1.8 times as much alcohol as gasoline for the same amount of power, with the engine at its best adjustment, while it was found possible by poor adjustment to double the consumption of alcohol. Engines designed for using alcohol, however, have shown a much higher thermal efficiency running on alcohol than the best gasoline engines running on gasoline. Since the burning of alcohol produces no smoke to reveal an improper mixture, the ordinary operator is very apt to use fuel wastefully. However, much attention is being given to the production of alcohol from cheaper materials by cheaper processes, and it is logical to expect that denatured alcohol will eventually be sold as cheaply as gasoline. This is especially true, since the price of gasoline is steadily advancing and much of the present high price of alcohol is due to the federal regulations imposed upon its manufacture. We may also expect even a greater degree of improvement in efficiency in alcohol engines than in gasoline engines, which are already in a high state of perfection.

Alcohol is derived from vegetable products by distilling a fermented mixture, a large per cent. of the heat value of the original material being lost in the process. Practically all vegetable products contain sufficient cellulose, starches and sugars to yield a considerable amount of alcohol. However, the cost of most raw material is so great as to make its use out of the question. Either it is too valuable for other purposes or the cost of bringing it to the still is prohibitive.

The sun is hottest at the equator, and since plants can store up only about one fifteen-hundredth part of the heat which streams down upon a given area, we may expect some day to derive the greater part of our alcohol from tropical plants. Aside from this source the need seems most likely to be met by the fermentation and distillation of wood waste, sugar-beet molasses, or potatoes and on the crops bred especially for the purpose. A bushel of such potatoes will produce from two thirds to one and one half gallons of 90 per cent. alcohol. The average production of ordinary table potatoes, even for the state of Maine, is about 275 bushels to the acre, while an acre of German alcohol potatoes often yields as high as 400 or 500 bushels. From two to three gallons of alcohol, used in the engine of the future, will suffice to plow an acre, hence one acre may furnish power enough to plow 200.

To put it another way, the sun stores up power enough in an acre of plants, in a single season, to plow, sow, and harvest that acre for a century, since, for most crops, plowing takes more power than all other operations put together. So long as the sun shines and rains fall, alcohol represents an inexhaustible and universal source of fuel, hence, even with the inevitable exhaustion of our stock of petroleum and coal, there is no cause for alarm. The immense deposits of the latter fuels seem to have been given to the world merely to sustain it until men could learn to use the power of the sun more directly.

Steel and gasoline made the gas engine a success. All our gasoline comes from petroleum. Neglecting alcohol

for the present, we usually think of some petroleum product when we discuss fuel for internal-combustion engines. Crude oil or petroleum is now generally thought to have been formed from vegetable or animal matter deposited in sedimentary rocks at the time of their formation. Oil and gas seem to have been produced by some sort of distillation, natural gas being a secondary product formed from the vaporization of petroleum. Petroleum is usually found at depths of from 300 to 2000 feet, or even more, under great pressure. The most profitable reservoirs or pools are found in inclined but unbroken strata of sand or porous rocks, covered with an impervious cap layer of shale rock or fine-grained limestone. The basins in which the oil accumulates are not underground caverns, but masses of coarse-grained rock. Oil, gas, and salt water are found together in nearly all oil fields. In fact, along our Pacific coast, and elsewhere, oil wells are sunk in the sands of the beach and sometimes in the ocean itself. The gas and water separate from the oil in layers according to density. In consequence the same field may have wells which tap the reservoirs at different points and produce natural gas, pure oil, and a mixture of oil and water, according to the layer tapped.

Crude oil, as it flows or is pumped from wells, is usually rather thick, of medium weight, and ranges from a light yellow or green to black in colour. Some oil, practically free from color, has been obtained from older geological formations. Some California oils are so heavy that they cannot be piped, hence are transported in V-shaped troughs. Coal as it comes from the mines is practically the same, except as to size, as when it gets to the consumer, though it varies in quality and composition according to the source from which it comes. Crude oil likewise varies a great deal in its original character, but it is different from coal in that the quality of its products can be further varied to an enormous degree by the method of refining.

If crude oil is left standing at ordinary temperatures a part of it will be given off as vapor. On a warm day more vapor will be given off before evaporation stops than on a cold one. Likewise, if the oil is placed on a stove more gas is given off and the remaining liquid grows denser. At each rise in temperature more of the oil is vaporized, until nothing is left but a solid residuum. This behavior shows that petroleum is not a uniform substance, but a mixture composed of large numbers of different compounds. In order to separate the oil into liquids which are uniform in quality a process similar to the one just described is used, this being known as *fractional distillation*. It consists of applying successively higher temperatures to the crude oil to vaporize the various compounds, which are again condensed, provided, of course, they are liquid at ordinary temperatures. Each time evaporation stops, the temperature of the liquid is raised and another portion is distilled over, until finally the volatile matter is all driven off.

From the foregoing it will be seen that petroleum contains: (1) some compounds which are gases at ordinary temperatures; (2) some which are normally liquid when confined, though evaporating quickly when exposed; (3) some which are liquid and require considerable heat to vaporize; (4) some which are normally liquid, vaporizing only with difficulty and at very high temperatures; and (5) some which for practical purposes are not volatile at all. The first group, roughly speaking, contains the natural gases. The second comprises the grades variously known as gasoline, benzine, naphtha, petroleum spirit, petrol, etc., and a few rare products not of commercial importance such as rhigolene and cymogene. The third group is made up of illuminating oils, kerosene, paraffin oil, etc. "Middlings," or "distillate," comes under this head, though as a matter of fact all the foregoing products are distillates of crude oil. The fourth group contains the heavy fuel, gas, and lubricating oils, while the fifth comprises the solid lubricants, paraffin wax, petroleum coke, pitch, asphalt, etc.

The weight of a given volume of these successive groups increases in a ratio roughly corresponding to their chemical composition. To obtain liquids which should each contain but a single chemical compound, hence be homogeneous in composition, the temperature of distillation for each fraction of the oil would have to be based on the boiling point of one compound. Even then it would be possible to obtain a pure chemical product only after several further refining processes, which would make the cost prohibitive. The very best commercial oils then, from the standpoint of uniformity, are the mixtures of several substances very nearly alike in composition and evaporating at nearly the same temperatures.

All petroleum distillates are composed of varying proportions of carbon and hydrogen and on that account are known as *hydrocarbons*. In the process of combustion they unite readily with oxygen, usually forming water and carbon dioxide, or carbonic acid gas. The lowest unit in which the two elements are chemically combined is known as the *molecule*, and the lightest molecule found in the Pennsylvania oils is that of marsh gas, or methane. It contains one atom of carbon and four of hydrogen, represented by the formula  $\text{CH}_4$ . The bulk of the more complex compounds occur in a practically regular series known as the paraffin series. Each contains one more atom of carbon and two of hydrogen than the one next below. Thus we have  $\text{C}_2\text{H}_6$ ,  $\text{C}_3\text{H}_8$ , etc., as formulas for higher compounds. The latter is the lowest which is normally liquid, being one of the lightest constituents of gasoline. The carbon atom is heavier than the hydrogen atom in the ratio of 12 to 1. The marsh gas molecule, therefore, is three fourths carbon.

Every reader knows that hot air will sustain a greater weight of vapor than cold air. A given volume of gas contains exactly the same number of molecules, no matter what kind it is; hence a cylinderful of kerosene vapor will weigh more than an equal volume of vapor from gasoline. From this fact arises the necessity for a higher temperature within the cylinder to

vaporize and burn kerosene than to handle gasoline, also the practice of running kerosene engines on gasoline for a moment on starting.

The only commercial standard of quality for liquid fuels ordinarily considered, aside from their color, is the Baumé

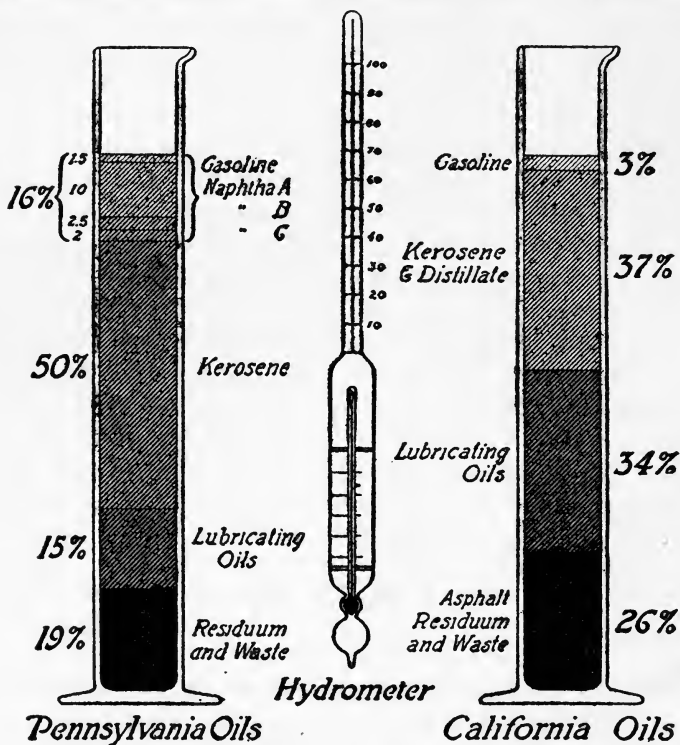

Composition of crude oils

gravity, in which the weight is compared with that of water. Water, which weighs eight and one third pounds per gallon at 60° F., is placed at 10° on the Baumé scale. Liquids heavier than water have a lower value and lighter liquids a higher value. The Baumé gravity may be calculated by the following formula

if the weight in pounds per gallon is known at a temperature of 60° F.:

$$\begin{aligned} (\text{Weight in lbs. per gal.} \times 12) \div 100 &= \text{specific gravity} \\ (140 \div \text{specific gravity}) - 130 &= \text{degrees Baumé} \end{aligned}$$

For example: Common engine kerosene weighs about 6.7 lbs. per United States gallon. Applying the first formula is equivalent to dividing by the weight of water, and gives a specific gravity of .804.  $140^\circ \div .804 = 174^\circ \div 130^\circ = 44^\circ$ , the Baumé gravity.

The crude oils from different districts vary widely in their weight and composition. Those from the Appalachian district have a paraffin base, while those from the Southwest and California have largely an asphalt base. The two latter yield a much lower percentage of the lighter oils, such as commercial gasoline or naphtha, and a larger quantity of the heavy fuel oils, lubricants, wax, and solid waste. The difference in weight of crude oils is shown in the following table of Baumé gravities:

DISTRICT	DEGREES - BAUMÉ
Pennsylvania . . . . .	42 to 50
West Virginia, Kentucky . . . . .	40 to 46
Ohio, Indiana . . . . .	37 to 40
Illinois . . . . .	30 to 34
Kansas, Oklahoma, Louisiana . . . . .	22 to 32
Texas . . . . .	16 to 26
California . . . . .	12 to 28

Though crude oil and its products vary in weight per gallon, they are remarkably uniform in heat value for a given weight. American crude oils range from 18,000 to 22,000 B.t.u. per pound, an analysis of fifteen from various sources averaging 20,400. A conservative estimate will place commercial gasoline and kerosene at 20,000 B.t.u. per pound.

The world's first systematic boring for oil occurred when the Pennsylvania field was opened in 1859, and, until the rapid introduction of the gasoline engine made greater produc-

tion necessary, this and the adjoining states supplied the great bulk of the petroleum refined in America. A work published prior to 1899 gives the following results from fractional distillation of a Pennsylvania petroleum having .80 specific (45 B.) gravity. The Baumé gravity is added by the formula quoted. It represents roughly the classification of petroleum products at that time:

TEMP. OF DISTILLAT'N. DEG. FAHR.	DISTILLATE	PERCENT- AGES	SPECIFIC GRAVITY	BAUME GRAVITY
113°	Rhigolene } petroleum	Traces	.590-.625	108-94
113°-140°	Cymogene } ether			
140°-158°	Gasoline (petroleum spirit)	1.5	.636-.657	90-83
158°-248°	Benzine, Naptha C, Benzolene	10.	.680-.700	76-70
248°-347°	Benzine, Naptha B	2.5	.714-.718	66-65
	“ “ A	2.5	.725-.737	63-60
	Polishing Oils	—	—	—
338° and upward	Kerosene (Lamp Oil)	50.	.802-.820	45-41
482°	Lubricating Oil	15.	.850-.915	35-23
—	Paraffin Wax	2.	— —	— —
—	Residue & Loss	16.	— —	— —

The products lighter than lamp oil comprised only about 16 per cent. of the total and showed a much wider range in gravity than kerosene.

The mid-continent and Western oil fields were opened at a much later date. They are now producing oil in abundance, but yield even a lower proportion of the lighter oils. The following recently compiled percentage analysis of a typical California crude illustrates the difference in character of supply:

Naphtha, gasoline, benzine, etc., 2.8; commercial “distillate,” 23.1; kerosene, 14.4; lubricants, 34.1; wax or asphalt, 21.4; residue and waste, 4.2.

Many of the former grades have now been abandoned and



the naphthas from 52° to 80° Baumé are commonly grouped together to form a yield of about 10 per cent. of commercial gasoline. The gasoline of to-day is the "Naphtha A" of ten years ago, while true gasoline is rare and issued almost solely for aeroplanes, racing automobiles and other extreme purposes. Distillates of 52° to 58° Baumé, which are now sold as benzine to the paint trade, become naphtha to the owner of a motor boat.

There are two ways in which fuel of a certain specific gravity can be obtained. One way is to distil into it only that fraction of crude oil which approximates the desired density, thus gaining a very uniform product. The other is to mix together distillates of high and low gravity so as to obtain a mean somewhere near what is required. It is obvious that at any given temperature a portion of the latter oil will evaporate at a much more rapid rate than the remainder, so that the oil left in the reservoir will continue to grow heavier. The ideal fuel is the one which is uniform in composition, as it is equally obvious that a carbureter adjusted to handle the lighter constituents will be unable to handle the heavier parts without readjustment. Uniform fuel would require but one adjustment of the mixture for any given condition of work. The weight or Baumé gravity of a liquid fuel is not a reliable indication of its composition — *i. e.*, its vaporizing qualities. Nothing but fractional distillation will disclose whether or not heavy and light products have been mixed.

If commercial fuel oils were pure chemical compounds it would be a much simpler process than at present to supply the proper conditions of temperature and mixture to insure perfect combustion. But we have seen that Pennsylvania crude oil, which weighs about the same per gallon as ordinary engine kerosene, is composed of substances varying from solid residues to liquids which vaporize at low temperatures. From this it is evident that the amount of uniform fuel of high Baumé gravity which could be supplied was always limited.

A long period of use and waste has exhausted many of the valuable wells. Not only that, but oil from the older fields has lost much of its volatile matter in the form of gas, and is heavier than formerly. Crude oil from other and newer sources has seldom duplicated the high percentage of light gravity distillates, hence has yielded even less of the high grade fuels. Heavy-producing foreign fields, also, generally yield oils of much greater density, and crude oil engines have been more in demand abroad than in this country.

High gravity fuel is constantly changing in quality and advancing in price. Makers of gasoline carbureters are constantly being forced to meet a new situation. In order to obtain fuel enough to supply the growing trade, and at the same time avoid mixing distillates of a wide range in weight, it will be necessary to use oil of comparatively low gravity on the Baumé scale. By using gasoline of 56° B. we can obtain a sufficient quantity from Texas and Oklahoma oils without straining the natural constitution of the oil. This in turn presents greater difficulty in carburetion and involves the changing of the design of most of the present carbureters. Once they are adjusted to heavier fuels, they should be able to handle them without difficulty, except on starting. To do so, however, will require automatic means for taking care of the constant variation in conditions presented by the changing loads. By adopting the lower gravity products the situation will become settled for many years. The heavier standard fuels can already be supplied in abundance, and permanent standards of quality can be set up for the benefit of refiner, user, and designer.

Great changes took place in the oil situation in the last few decades. Forty years ago kerosene was refined for use in lamps, while gasoline was a by-product. Gasoline of 76° to 85° B. was disposed of in enormous quantities by burning in the open air. The change in quality of crude oil brought a decrease in the percentage of gasoline and an increase in the

percentage of kerosene. Where Pennsylvania oils formerly yielded as high as 16 per cent. of gasoline, benzine, and naphtha, they now yield less than 10 per cent., and the Appalachian district, which includes the surrounding states, yields now only about 15 per cent. of the total supply of crude oil. The Illinois, the mid-continent fields, Texas and California, now yield from nine to thirteen gallons of kerosene and so-called engine distillate to each one of gasoline where distillation is complete. Furthermore, the commercial gasoline is much less volatile, having been lowered from 76° to 60° B., in about fifteen years. The percentage of gasoline of the former quality from the present heavy-producing districts would be practically negligible.

The shift of the centre of production has been no less rapid than the invention of apparatus for using the more volatile hydrocarbons. The gasoline stove taught the people the use of gasoline, and during the last two decades the development of the gas engine for automobile, stationary, traction, marine, and commercial purposes has increased the demand by leaps and bounds. The domestic consumption of gasoline has increased from 14,000,000 gallons in 1905 to 50,000,000 gallons in 1910. A surplus of kerosene is being refined simply to furnish an adequate supply of gasoline, even though much of the crude oil at the present time is merely skimmed — *i.e.*, the gasoline is taken out to supply the present demand, and the rest, including the kerosene, either stored or used for fuel under steam boilers.

The use of the kerosene lamp is now all but confined to rural districts. In many large sections of the country the consumption of kerosene for all purposes is less than that of gasoline. The tail wags the dog. Gasoline, formerly a by-product of illuminating-oil refining, is now the only petroleum product which taxes the capacity of the refineries. Refiners have stored kerosene to the limit of their tank capacity, and from every source comes the information that unusual methods

are being adopted to create a demand for it. Oil companies are pushing the kerosene stove instead of the gasoline stove. They are handling oil heaters, lanterns, lamps and every device for increasing kerosene consumption. Refiners are stipulating the purchase of a carload of kerosene with every carload of gasoline.

In the ten years previous to 1909 the export value per gallon of naphthas rose 56 per cent. as against 19 per cent. for kerosene and practically nothing for crude oil. The exports of kerosene increased twenty-three and one half times

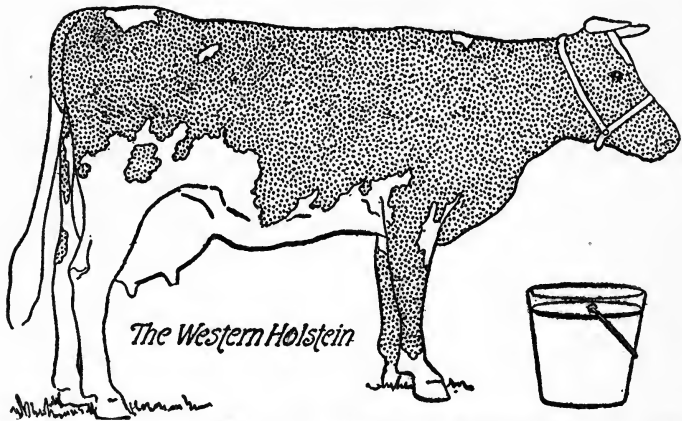

*The Western Holstein*

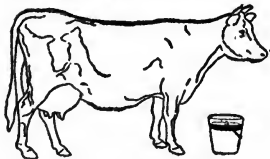

*The Pennsylvania Jersey*

The bigger the cow the thinner the cream faster than those of gasoline. Even in far-off China 400 million people are being taught the use of our discarded kerosene lamp, to provide a market for the by-product.

It is difficult now to secure the lightest crude oil products in the open market, since they assist the refiner to dispose of some of the heavier compounds in mixtures sold as commercial gasoline. A prominent oil man says that the proposition is like that of a dairy farmer. His Jersey cows can produce

only a certain amount of milk to supply a certain town. Some of his cows go dry, Jerseys are scarce, and he has to replace them with Holsteins which give more milk but less cream. At the same time new-fangled breakfast foods have increased the demand for cream. The dairy man at first has his choice of two courses: first, to advance the price of cream and throw away the skim milk entirely; and second, to dilute the cream with as much skim milk as he dares, sell the rest of the milk for what he can get, and make up the profits by advancing the price on the lower grade of cream. In order to meet the demand for cream he is finally forced to the latter course. In this comparison the Jersey cows may be likened to the Pennsylvania oil wells, which produced a higher percentage of gasoline than any other oil field ever opened. The Holsteins which replace these are the oil wells of Oklahoma, Texas, and California, which yield even more oil, but of lower quality from the vaporizing standpoint. The breakfast foods are the hundreds of thousands of gasoline engines used for every conceivable purpose. It is not a question now of the price of kerosene or gasoline.

The problem is to supply the demand for the latter and dispose of the former on any basis whatever. The scarcity is not of whole milk but of the cream in that milk. In consequence of the changes there has been a natural shift in prices. Gasoline has increased threefold in price in fifteen years and is steadily advancing. Engine kerosene, on the other hand, is about one seventh the price received for illuminating oil twenty-five years ago, and in the last two years has declined 40 per cent. in price at the refinery. It costs now from one third to two thirds as much as gasoline, according to the amount of freight which is added after it leaves the refinery. The cost of the lighter oils such as gasoline and benzine, is even higher in Europe than in America owing to the scarcity of the lighter constituents in Russian and Roumanian oils. The question naturally arises as to the future of fuel for gas engines, as

there is abundant petroleum for many generations, provided ways are found to make economical use of it all. The present rate of expansion of the supply is due to the fact that most common internal combustion engines have been capable of using only the slight percentage of oil which is refined into gasoline, while a large part has been wastefully burned under steam boilers. There is no cause for alarm as carburetors can be made to handle the heavier fuels if the latter are at all uniform, and they are more apt to be so than is gasoline at present. It is simply necessary for manufacturers to reconcile themselves to the situation and develop carburetors for handling fuel which can be supplied in adequate quantities without leaving an enormous surplus of unsalable by-products. In any event, there is no use in complaining, as gasoline cannot even now be furnished in sufficient quantities. The world has plenty of crude oil that will yield the heavier distillates. The principal producing fields are in Russia and America, which together, yield about 90 per cent. of the supply. Galicia, Roumania, and India yield about 4 per cent., and the remainder comes from Canada, Sumatra, Java, Borneo, Burmah, Japan, Germany, Austria, Italy, and newer fields. It is being found in new places each year. Nearly every South and Central American country has been found in the last few years to contain paying deposits.

Oil has been found in paying quantities in Pennsylvania, West Virginia, Kentucky, Ohio, and Indiana, which form what is known as the Appalachian group. Illinois, Kansas, Oklahoma, Louisiana and Texas produce abundantly and California constitutes still another important area. The real development of Texas and Oklahoma as important fields did not begin until about 1902. From 1902 to 1908 Texas produced 122,500,000 barrels and an immense area of costal plain has not yet been tapped. In 1907 Oklahoma produced over 44,000,000 barrels and it was estimated that only one per cent. of the state's oil and gas has been developed. It

has recently been estimated that in California it will take oil companies one hundred years at the present rate simply to open up the field, and new fields have just been discovered in the Northwest.

Canada produces about one fifth of the petroleum fuels consumed in the Dominion. At the present time all grades of gasoline, benzine, and naphtha are brought in free of duty, provided they are lighter than .730 specific gravity. This fuel corresponds to about  $63\frac{1}{2}^{\circ}$  B. All grades of crude oil heavier than .8235, corresponding to about  $40^{\circ}$  B, enter free. Kerosene and light-coloured engine distillate must pay a duty of  $2\frac{1}{2}$  cents per imperial gallon, which brings the price relatively much nearer the price on gasoline than in the United States. The imperial gallon used in Canada is one fifth larger than the standard gallon of the United States.

Petroleum fuels are commonly shipped to distributing points in tank cars holding from 6000 to 8000 gallons. From these points they may be distributed by means of tank wagons holding about 500 gallons, or in steel or wooden barrels of 42 gallons each. In many localities wonderful tank wagon service brings fuel to the farmer's door at, or very slightly above, the wholesale price. Most operators find it convenient and even necessary to own tank wagons of their own, either for hauling from the distributing point or for service while the engine is at work in the field. The storage of gasoline or kerosene on the farm previous to the opening of the season's work has many advantages. A better price may often be obtained and the work can be done more cheaply at odd times.

In storing gasoline it must be remembered that the vapor is given off very readily and is extremely difficult to confine. Being heavier than air, it will spread out and flow along the ground. In consequence, a light even at some distance may ignite the gas and cause a flame to travel back to the place of storage. Before this was understood and the necessary precautions taken this caused many accidents in the oil districts.

A cubic foot of gasoline vapor will form a violently explosive mixture with a large quantity of air, at ordinary temperatures, hence we can readily understand the cause of many explosions where volatile oils are kept in enclosed rooms. Absolute freedom from leakage is therefore an important essential. Steel tanks are to be preferred to wood receptacles, and welded to riveted seams.

It frequently happens that the evaporation from the surface of gasoline is sufficient to reduce the temperature to the point at which moisture from the adjacent air will condense upon the surface. Being heavier, the water will find its way to the bottom of the tank. As the pump to the carbureter is usually connected with the lowest point in the storage tank, water is thus very apt to get into the carbureter and stop the engine. There are many patent filters for removing water, the common chamois skin being employed in a great many. The gasoline passes readily through this fabric, leaving the dirt and water behind.

Dirt finds its way into the storage tank through careless handling of the fuel, through rusting of some of the parts and through the chipping off of small pieces of solder. These are naturally pumped into the carbureter, where they clog the small needle-valve openings and stop the engine for lack of fuel. Great care should be taken to keep the storage tanks clean and to prevent the introduction of water and dirt in fuel.

The water required by gas tractors varies with several factors, such as the load, the atmospheric temperature, and the type of cooling system used. In brake tests during tractor competitions, where steam engines used from 28 to 36 lbs., gas tractors used from practically nothing up to 2.9 lbs. of water per brake-horsepower hour, averaging about  $1\frac{1}{3}$  pints. The non-evaporating cooler required the least, and the simple evaporating cooler, the most. Some kerosene tractors which do not use water for cooling, use it in connection with the fuel in the cylinder, at from half to full load. In this case



the ratio of water to fuel increases with the load until at full load it is practically 1.1. Roughly, it may be said that few gas tractors use a barrel of water per day in the heaviest work during the hottest weather.

### THE PLOW

Will H. Ogilvie, in the *London Spectator*

From Egypt behind my oxen, with their stately step and slow,  
Northward and east and west I went to the desert sand and the snow;  
Down through the centuries, one by one, turning the clod to the shower,  
Till there's never a land beneath the sun but has blossomed behind the power.

I slide through the sodden rice-fields with my grunting, hump-backed steers,  
I turned the turf of the Tiber plain in Rome's imperial years;  
I was left in the half-drawn furrow when Cincinnatus came,  
Giving his farm for the Forum's stir to save his nation's name.

Over the seas to the north I went; white cliffs and a seaboard blue;  
And my path was glad in the English grass as my stout, red Devons drew;  
My path was glad in the English grass, for behind me rippled and curled  
The corn that was life to the sailormen that sailed the ships of the world.

And later I went to the north again, and day by day drew down  
A little more of the purple hills to join my kingdom brown;  
And the whaups wheeled out to the moorland, but the gay gulls stayed with me  
Where the Clydesdales drummed a marching song with their feathered feet  
on the lea.

Then the new lands called me westward; I found on the prairies wide  
A toil to my stoutest daring and a foe to test my pride;  
But I stooped my strength to the stiff, black loam, and I found my labor sweet  
As I loosened the soil that was trampled firm by a million buffaloes' feet.

Then farther away to the northward; outward and outward still,  
(But idle I crossed the Rockies, for there no plow may till!)  
Till I won to the plains unending, and there on the edge of the snow  
I ribbed them the fenceless wheat fields, and taught them to reap and sow.

The sun of the Southland called me; I turned her the rich brown lines  
Where the paramatta peach trees grow and her green Mildura vines;  
I drove her cattle before me, her dust and her dying sheep,  
I painted her rich plains golden, and taught her to sow and reap.

From Egypt behind my oxen, with stately step and slow,  
I have carried your weightiest burdens, ye toilers that reap and sow  
I am the ruler, the king, and I hold the world in fee;  
Sword upon sword may ring, but the triumph shall rest with me.

### XIII

## EARLY HISTORY OF THE PLOW

**T**HE plow is our oldest agricultural implement. Indeed, systematic agriculture began when man first took his crude war club and with it stirred the soil. The shape of the primitive plow suggested the first letter of the alphabet. The Book of Job is the oldest part of the Old Testament, yet this work begins: "And there came a messenger unto Job, and said, The oxen were plowing and the asses feeding beside them; and the Sabeans fell upon them and took them away; yea they have slain the servants with the edge of the sword; and I only am escaped alone to tell thee." Ancient monuments, dating back forty centuries, bear sculptured representations of the plow. Ulysses was plowing among the sands of the shore at Ithaca

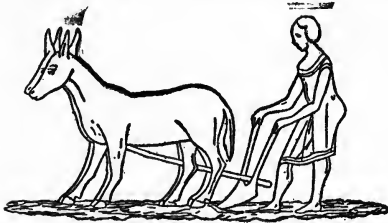

From an Egyptian monument, 3000, B. C.

when he feigned madness before the messengers of Agamemnon. Virgil describes the plow used by Cincinnatus, and Horace, warning the Roman Republic against encroachment of the nobles' fish ponds upon the peasants' fields, writes

in his Ode, "only a few more acres are left for the plow." Ceres, the patron Goddess of Agriculture in Greek mythology, inspired Triptolemus to invent the plow at the time she taught him the art of husbandry and placed him in charge of her work

of distributing corn to all the inhabitants of the earth. The ancient Egyptians had progressed from the crooked stick to a plow consisting of wooden beam, shank, and handle. As early as 1100 B. C., two thousand years before the horse was harnessed to the plow, the Israelites, who were unskilled in working iron, "went down to the Philistines to sharpen, every man, his share and his coulter."

History does not give the date of the first plow nor the name of its inventor. The earliest records chronicle its general use in the preparation of the soil for the harvested crop, but long before written history began men must have observed that the loosened earth bore most abundantly. Perhaps the snout of the wild boar, in its quest for grubs, suggested the shape. A bludgeon sharpened to a point was the crude imitation, and later a widening of the point into chisel shape made the instrument more rapid in its work. The primitive man — the savage — unused to monotonous toil, first yoked his womankind to the plow, then, with forked stick and thong pressed into service the cattle grazing on the hillsides about him. The long end of the fork at the horns of the bull, the short in the ground, the trunk as a handle, and the plow was invented. The marvelous ease with which the new implement loosened the soil, as compared with the muscle-straining drudgery of the pointed stick, overwhelmed the devout and overawed the superstitious. Plow and power alike took on Olympian attributes. A writer of the last mid-century suggests that the early and widespread belief in the divine origin of agriculture, which discouraged as impious any improvement in ancient processes, may have been responsible for the centuries which passed without any alteration in the character of the plow. Certain it is that in many parts of the world, to some extent even in the very foremost agricultural districts, nothing is harder to introduce than new farm methods, as though the shadow of that ancient delusion still fell upon the tiller of the soil. The native Egyptian plow from the valley

of the Nile shows no improvement over the plows of five thousand years ago; in Mexico and Spain the wooden plow of the Moors outnumbers the steel plow of America; all of our civilization lies this side of the stick-plow of the Cingalese.

The first plows for brute power were made wholly from the natural crooks of the branches of trees, each with a brace added



Plow from Asia Minor

to strengthen the union between the beam and the upright share. Pins in the forepart of the beam connected it with the square yoke then used on draft oxen, and a natural crook

gave the plowman a handle for guiding. Such were the plows used by Job and Ulysses.

Three thousand years before the Christian Era the Egyptians had evolved a broader, triangular share to take a wider furrow than the plow of Asia Minor just described. Two handles in place of one made it easier to guide. The plow used by Cincinnatus and Cato was an improvement over a still older form used in the days of the Tarquins. Their plow for a long time seemed incapable of improvement. Virgil, in his Georgics, describes the plow of his day, which coincides with the earlier descriptions. It had a point made of two pieces of wood meeting at an acute angle. An iron plate covered the point, and two pins, or teeth, set obliquely, one into each leg of the angle, performed the office of a moldboard in lifting and pulverizing the soil.

In Britain an implement called the caschrom served the early husbandmen, and was in use in the Hebrides and the Isle of the Sky until late in the nineteenth century. A single curved piece of wood, the lower



Javanese stick plow

end nearly horizontal, the upper resting on the plowman's shoulder, forms the share, beams and handles of the caschrom.

The only additions of inventive genius were a sidewise projecting pin for convenience in regulating the depth by the foot and an iron chisel-point for the share.

The plow up to this point was merely an instrument which pulverized the soil by passing through it and disturbing it in its place. Next came the conception of the plow as a wedge for moving the earth and redepositing it in a broken condition. Some wedges acted horizontally, lifting the earth and allowing it to fall back in the furrow. Others acted laterally, pushing

aside the furrow slice and leaving a clear space for the next furrow. Plows in which this crude application of the single wedge is found are still widely used in Mexico and Spain, occasionally in France and

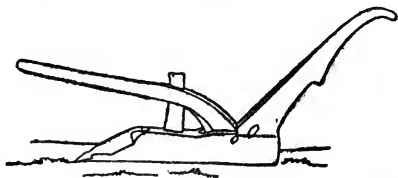

Ancient Mexican plow. This type still used

Italy. They represent the only improvements in plows during the long Middle Ages over the round-pointed or triangular sticks of the ante-Christian Era. Except for the invention of the coulter about the eleventh century no one had

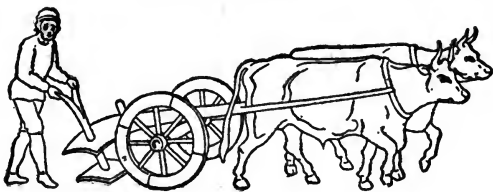

Old English plow, 1470 A. D.

yet conceived the idea of both lifting the soil and shoving it aside by a combination of horizontal and lateral wedges, though in a type of French plow used in the Middle Ages a hint of the modern curvature of share and moldboard is given.

## XIV

### THE PLOW IN GREAT BRITAIN

**T**HE Dutch, owing to the difficult conditions to be met in their lowlands, were among the first really to improve upon the primitive Roman plows. They evolved a moldboard which twisted and turned aside the furrow, and protected the wooden parts from ground friction by a covering of iron. The revival of interest in agriculture in England in the early part of the eighteenth century turned concerted attention toward the improvement of the plow. Some of the Dutch plows imported about this time were copied by English makers. The first of these, known as the Rotherham plow, was made by Joseph Foljambe, of Yorkshire, who received letters patent in 1720. Foljambe's plow, as afterward made by Staniforth, was of wood, with a short-lived sheet-metal covering. The point was conical, rather than sharply chiseled, and burrowed rather than cut its way. A bridle, or clevis, was provided for the first time so the point might be set for depth and either to or from the land. The vertical and horizontal wedges were combined in the moldboard and connected by a curved line, so that the furrow slice was first raised a little and gradually inverted clear of the space in which it lay.

Jethro Tull, published in 1731, the first edition of his "New Horse Houghing Husbandry." In this work, the outgrowth of his travels and experiments, he set forth radically new theories. He emphasized the beneficial effects of tillage after the sowing of the crop, the current practice being to perform the entire work

of cultivation during the preparation of the seed bed. He saw that the more finely divided the soil, the more readily plants grew, and "the stronger the soil is, the more benefit will it receive from this method of culture, if the land be thereby more pulverized." While devising many interesting horse-drawn tools, the more easily to carry out the methods he proposed, he gave much attention to the improvement of plows.

"'Tis strange," Tull says, "that no author should have written fully of the Fabric of Ploughs! Men of the greatest Learning have spent their Time in contriving Instruments to measure the immense Distance of the Stars, and in finding out Dimensions, and even Weight of the Planets; they think it more eligible to study the Art of plowing the Sea with Ships than of tilling the Land with Ploughs; they bestow the utmost of their Skill, learnedly, to prevent the natural Use of all the Elements of Destruction of their own Species by the Bloody Art of War. Some waste their whole Lives in studying how to arm Death with new Engines of Horror and inventing an infinite Variety of Slaughter; but think it beneath Men of Learning (who only are capable of doing it) to employ their learned Labors in the Invention of new (or even improving the old) Instruments for increasing of Bread."

Tull was the first to proclaim aloud the necessity for intensive cultivation. In his time the present countless variations in tillage implements were not available for purposes of "The

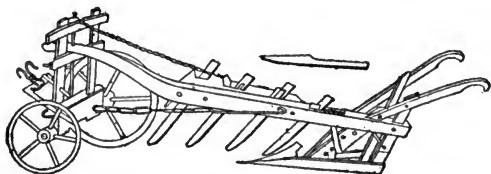

The old Berkshire four-coultered plow

v

New Husbandry," hence it is not surprising to find him giving preference, not to the Rotherham plow, which approached

more closely than any other of that time, the modern implement, but to the old Berkshire plow. This plow had a pair of wheels to support the beam and a clumsy device by means of which front of latter could be elevated or depressed to change the depth of plowing. The point was of iron, also the ground wrest, which in later plows has been superseded by the continuation of the point into a share. The ground wrest was placed at an angle to the landside in the horizontal plane, like the edge of a modern share, but stood nearly perpendicular to the bottom of the furrow. It constituted the wearing plate and supported the wooden moldboard. The latter, only slightly curved, joined the ground wrest at an angle which was sufficient to invert the furrow slice. In shape and ease of draft it was inferior to the Rotherham plow, but in its four-knife coulter it possessed the capacity for pulverizing the soil better than any previously known tillage implement, and this outweighed all other considerations with Jethro Tull. Three of these coulters were mortised into the beam ahead of the plow point, and the fourth about midway between the point and the forepart of the moldboard. Each of the last three was an equal distance to the left and rear of the one ahead, and inclined a trifle more from the perpendicular.

Tull's argument in favor of the plow is substantially as follows: "It divides the land more completely, affording greater access to air and moisture. The furrow being cut into four parts, it will have four times the superficies that it would have without the coulter cuts; but this is not all. It is more divided crossways, *viz.*: The ground wrest presses and breaks the lower (or right hand) quarter; the other three quarters, in rising and coming over the earth board, must make a crooked line about a fourth longer than the straight one they made before being moved; therefore, their thinness not being able to hold them together, they are broken into many more pieces for want of tenacity to extend to a longer line. This is contrary to a whole furrow, whose great breadth enables it to



stretch and extend from a shorter to a longer line without breaking, and as it is turned off the parts are drawn together again by the spring of the turf, and so remain whole after plowing."

Tull's analysis of the objects desired and the exact manner in which the old Berkshire plow accomplished them should have led to a much earlier solution of the problem. His system of horse-hoe husbandry, however, was derided at the time and the four-coultered plow was never widely adopted. Its functions have since been accomplished by more scientifically shaped plows and other tillage tools, but, as will be seen later, in much the same manner as he described nearly two centuries ago.

James Small, of Scotland, took the Rotherham plow and from it made a light draft instrument which turned the furrows smoothly, without crumbling them. His factory at Black

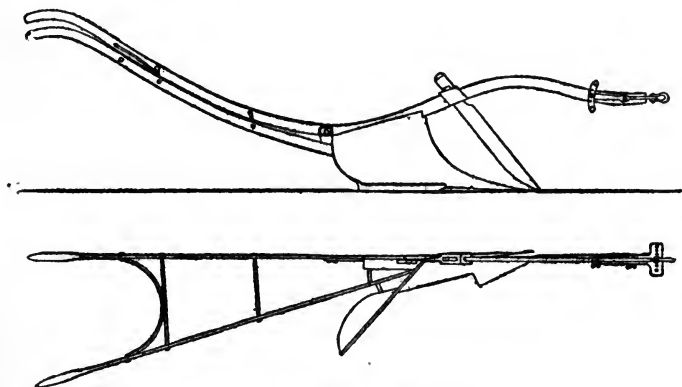

Small's East Lothian plow

Adder Mount in Berwickshire was established in 1763, and before his death, thirty years later, he had so perfected the plow by experimental methods that almost exact duplicates of his models are still popular in Scotland. Many of these plows, with moldboard of cast iron, and share, beam, and handles of

wrought iron, are to be found in Ontario and Quebec, still known as of the old Scotch model.

Small's crowning achievement was the East Lothian plow. It had a curved beam, which was continued to form the left handle. From the points of the share of a perpendicular line, dropped from the fore end of the beam, the plow measured about twenty-four inches, only slightly more than the twenty-inch projection customary in modern walking plows. The handles, however, extended about five and a half feet backward from the rear point at which the moldboard touched the ground, as compared with about three feet from the heel of the share at present. In many of the later models handles seven to eight feet long were added. A keen blade coulter extended from the beam at an angle of about fifty-five degrees to landward to just opposite the point of the share or sock. The moldboard, instead of being fitted to the upper edge of the share, as is common in modern American plows, was set into the rear of the share, forming a continuation of the neck, or gorge of the latter. Its front edge, or breast, stood vertically, continuing the landside. Its heel was nine inches distant on the ground from the plane of the landside, while its upper edge overhung the heel a distance of ten inches on the furrow side. The plow bottom, or sole, was thirty-six inches long. The extreme breadth of the share was from six to six and one half inches, but the moldboard, which was set only a half inch above the base line, served to tear loose several inches of uncut earth and turn a furrow ten to twelve inches wide. The bridle, by means of which the plow was made to run deeper or shallower and to or from the land, was a distinct step in advance and has not been changed materially up to the present time.

One reason for the long-continued popularity of Small's plow lies in the ideal of plowing which prevails in Great Britain. A high-shouldered, sharp-cornered furrow is desired, one furrow slice lapping its neighbor, perfectly straight and unbroken from one headland to the other. The angle of the

coulter insured a sharp crest on the furrow edge left uppermost. The narrow share and long curving moldboard turned over a deep furrow without wrenching it apart, and the narrow cutting edge made it possible to maintain the proper depth of furrow, even in hard ground. The resulting plow was one which would not, of itself, swim freely, but the long handles gave the plowman the easy control essential to a straight furrow. The plow is not regarded in England as a pulverizing instrument; hence there is little longitudinal twist to the moldboard, and only enough vertical curvature to invert the furrow slice. Small's plow did not crumble the crest of the furrow slice, and this, rather than its lightness and superior mechanical construction, rendered it immediately popular. The same feature to-day leads British farmers to give preference to plows of heavy draft but capable of turning their ideal furrow.

By this time the conception of a plow as a combination of vertical and lateral wedges had been expressed in practice, if not in words. While shapes had been rendered in iron, plow-making was largely the joint office of the village carpenter and blacksmith, each of whom often carried out his ideas without reference to the other's. Plows were generally of wood, faced with strips of iron, or cast-off horseshoes. The shaping of plows was largely empirical. One good plowmaker after another lived, flourished, and died, and his art died with him for lack of a formula for transmitting his results to his successor. The maker himself could seldom duplicate an exceptionally fine plow, and real progress was slow. There gradually came a conviction, however, that some definite rule — some law of nature — should govern the shape of the plow, that in some way the cumbersome implement could be simplified, lightened, its draft diminished.

To Thomas Jefferson, third President of the United States, must be given undying fame for evolving a mathematical analysis of the moldboard, one whereby its shape could be forever

established, or altered with a foreknowledge of the results. His discovery marked a real epoch in agriculture and the beginning of the march of progress which has brought to us the perfect implement of to-day. He first brought denial to Jethro Tull's lament of a half dozen decades before, and was the leader of a long line of men who, for the nation, have fulfilled the prophecy of Isaiah — "They shall beat their swords into plowshares, and their spears into pruning-hooks." His contribution to the history of the plow was really first utilized in Europe.

During a trip through Lorraine in 1788, while serving as American Ambassador to France, Jefferson observed carefully the teams and implements used by the plowmen. In his diary he wrote: "Oxen plow here with collars and hames. The awkward figure of their moldboards leads one to consider what should be its form. The offices of the moldboard are to receive the sod after the share has cut under it, to raise it gradually and to reverse it. The fore end of it should, therefore, be horizontal, to enter under the sod, and the hind end perpendicular, to throw it over, the intermediate surface changing gradually from the horizontal to the perpendicular. It should be as wide as the furrow, and of length suited to the construction of the plow." He proposed a plan not only for making a moldboard which would present the least possible resistance to the passage of the earth, but for making any number of such moldboards by a common workman, using a process so exact that their forms should not vary by the thickness of a hair. On his return to America, having formulated his theories into a practical rule, he made several plows, and in 1793 put them into use on his estates in Albemarle and Bedford counties, in Virginia. He satisfied himself as to their practical utility and, probably before any other American inventor, proposed to have his moldboards made in future of cast iron. The English Board of Agriculture elected Jefferson an honorary member, and the French Academy ac-

knnowledged him as the inventor of the moldboard founded on mathematical principles.

Jefferson demonstrated that the shaping of the moldboard could be reduced to an exact basis, but his plow was defective in many points. A diagonal drawn on the surface of the plow from the point of the share to the tip of the overhang on the moldboard was a straight line. At every point on the diagonal an intersecting line touching the upper and lower edges of the moldboard would have been straight. On a vertical section of the moldboard, at any point except one, the line representing the face of the moldboard would have formed the hypotenuse of a right triangle if taken with the base line and a perpendicular dropped from the upper edge of the moldboard. The one exception is where points in the upper and lower edges were in the same vertical line. The absence of curves made it necessary to make the moldboard twice as wide as the furrow to prevent the earth from surmounting it and falling behind in the furrow. For the same reason it was necessary to make the moldboard very long and the twist very gradual.

This reduced moldboard friction in one way, but the long bearing surface offset this advantage. It was impossible to secure enough overhang to turn the furrow under all conditions without making the share too blunt and the plow impractical on account of draft. Small, in Scotland, had in the meantime worked out by experiment the moldboard on his East Lothian plow, which, when analyzed, is seen to have followed a curve instead of a straight diagonal. This allowed a greater overhang, without too blunt a share, and the precise nature of the curvature back of the centre of the moldboard reduced the abrasion of the crest of the furrow, as previously noted.

After Small, Mr. Wilkie, of Uddingstone near Glasgow, was the next to alter the shape of the plow. His inventions were embodied in the Lanarkshire plow, the moldboard of which presented convex lines to the passage of the furrow slice, and thus minimized the friction on the cherished crest. He also

raised the heel, or rear corner, of the share above the point. Thus he produced a furrow of trapezoidal section, partially to reduce the draft, but mainly to secure a sharper angle to the crest. These features are still in vogue and this plow has always been a close rival of the East Lothian among farmers who wish to see their furrows stand like saw-teeth. For plowing matches in Eastern Canada, even in late years, manufacturers have built special plows incorporating these features, though plows for general use have conformed more closely to modern practice.

Early in the century Stephens, in his "Book of the Farm," gave a mathematical method of shaping the moldboard. This was similar to Jefferson's, but by using the arc of a circle to generate the surface lines, instead of a straight diagonal, he produced a greater overhang at the rear and an easier slope in front. He conceived of the furrow slice as a right prism, elastic enough to yield to the passing form of the plow, and tenacious enough to resume its shape when laid in position. The slice must be turned on the lower right-hand edge as an axis through an arc of 90 degrees, then on what was the upper right-hand edge, through 45 degrees more, leaving it on a 45-degree slant instead of completely inverting it. To accomplish this he proposed a wedge, twisted on its upper surface, and to find the form and dimensions of this wedge was, in his mind, to solve the problem of the shape of the moldboard. His plow was the first on which the neck of the share was eliminated, the moldboard extending forward to form an angle with the heel of the share. In this respect, and in making the share cut the full width of the furrow, his plow still further resembled modern American practice. He advocated the use of malleable in place of cast iron for the moldboard by reason of its resistance to shocks, though pointing out the increased cost. The ideas worked out in Scotland by Small, Stephens, and Wilkie have influenced the design of plows to the present day.

In England a great step in advance was made when, in 1785, Robert Ransome, of Ipswich, obtained a patent for making plowshares of cast iron, and again in 1803, when the same man perfected a method of case-hardening, or chilling, shares. Between 1800 and 1810 the plow made entirely of cast iron came into general use, and for the next quarter century the changes were largely in the way of local adaptations. About 1840 Rev. W. L. Rham proposed that all lines of the plow running from front to rear should be straight, the vertical lines being suited to the different soils — *i.e.*, convex for stiff clay, straight for mellow loams, and concave for sandy and loose soils. His theories were generally adopted in England, and in America plowmakers

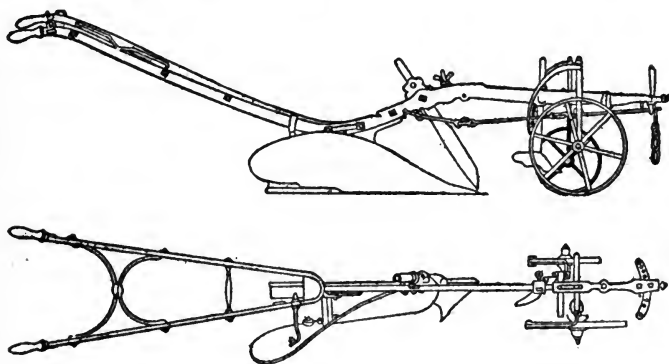

Howard's plow. The utmost perfection in English plows of 1870

were already following Pickering's teachings in this respect. About the same time, Mr. Howard had produced a plow with a share closely resembling modern types. Both his plow and Ransome's had jointers, gauge wheels, knife coulters and other improvements, and represented the latest stage of perfection. Factories established by these two men are still in operation.

## XV

### THE PLOW IN AMERICA

**T**HE policy of England toward Colonial America was not such as to encourage manufacture, and few plows seem to have been imported. In 1631 there were but thirty-seven plows in Massachusetts Bay Colony. Owners were frequently granted a bounty for keeping plows in condition to do the work of the entire town. By 1648 the Colony of Virginia had one hundred and fifty plows. The Colonial wheeled plow of 1748 was clumsy and short. Kalm, in his "Travels in North America," writes: "The ill-shaped share and moldboard did not plow deep or straight, and great strength and skill were necessary to guide the plow. The wheels upon which the plow beam is placed are as thick as the wheels of a cart, and all the woodwork is so clumsily made that it requires a horse to draw the plow along a smooth field."

Jefferson's work was in advance of his generation. His scientific principles were lost in America during the first quarter of the last century, and the improved methods of Stephens and others had not been put into practice. Until the beginning of the nineteenth century plows were made by rule of thumb and by the least qualified artisans. A. B. Allen, in 1856, described the methods as follows:

"A winding tree was cut down, and a moldboard hewed from it, with the grain of the timber running so nearly along its shape as it could well be obtained. On to this moldboard, to prevent its wearing out too rapidly, were nailed the blade of



an old hoe, thin straps of iron, or wornout horseshoes. The landside was of wood, its base and sides shod with thin plates of iron. The share was of wood, with a hardened steel point. The coulter was tolerably well made of iron, steel edged, and locked into the share nearly as it does in the improved lock coulter plow of the present day. The beam was usually a straight stick. The handles, like the moldboard, were split from the crooked trunk of a tree, or as often cut from its branches. The crooked roots of the white ash were the most favored timber for plow handles in the Northern States. The beam was set at any pitch that fancy might dictate, with the handles fastened on at almost right angles with it, thus leaving the plowman little control over his implement, which did its work in a very slow and most imperfect manner."

The Old Colony plow, as used in the Eastern States as late as 1820, had a ten-foot beam and a four-foot landside. "Your furrows stand up like the ribs of a lean horse in March. A lazy plowman may sit on the beam and count every bout of his day's work."

The first American after Jefferson to advance a real improvement was Charles Newbold, of Burlington, N. J., who made the first cast iron plow ever made in America. It was cast all in one piece, share, landside, sheath (or standard), and moldboard. Cast and wrought iron shares were in use before Newbold's invention, but in some way farmers developed the notion that the use of cast iron poisoned the land, injured its fertility, and promoted the growth of weeds, and Newbold's plow was never generally adopted. As late as 1837 farmers in New Hampshire clung to this idea.

Gideon Davis, in 1818, patented a plow built on the lines laid down by Jefferson. He also fastened the coulter to the side of the beam instead of perforating the latter. This greatly strengthened the beam as compared with the usual practice. September 1, 1819, on which date Jethro Wood patented his plow, has been set by some as "the natal day of the modern

plow." He developed in theory and worked out in practice both the vertical and transverse straight lines of the moldboard which had been presented in theory by Timothy Pickering, and by Thomas Jefferson in practice. He made a light iron plow, on which the pressure of the furrow was evenly distributed over the surface, so that the wear was equal on all parts. His greatest contribution to progress, however, lay in the interchangeability of parts, so that a broken or wornout casting might be replaced by any farmer. He thus instituted the era of plow manufacture, as distinguished from that of plow building in small quantities by local carpenters, blacksmiths, and plowwrights. To his everlasting credit it may be said that he was instrumental in driving out of use thousands of the clumsy "Bull" plows in existence. Sadly enough, Wood died a poor man. He spent his fortune in protecting his patents. A grant of \$2000 to his heirs by the New York State Legislature was the only substantial compensation growing out of his efforts to improve the plow. William H. Seward, Lincoln's Secretary of State, said: "No citizen of the United States has conferred greater economical benefits on his country than Jethro Wood — none of her benefactors have been more inadequately rewarded."

Pickering noted that the soil, when adhesive, filled the hollow of the moldboard and assumed a straight line from its fore end, near the point of the share, to its upper projecting hind corner, also that it maintained that same straight line. This struck him as proof that this straight line should exist in every moldboard as essential to the form giving the least resistance. Said he: "No earth can be left on such a moldboard; for every succeeding portion of earth which the plow raises pushes off that which is on the transverse straight line behind it; and the face of the moldboard consists — is made up (mathematically) — of an infinite number of such transverse straight lines."

Edwin A. Stevens, in 1817, so shaped a moldboard that it

would take a land polish over its entire surface. He also invented a process for cold chilling the base of the landside and the lower edge of the share, not knowing that that same thing had been done by Ransome, in England. This improvement lengthened the life of these wearing parts. Henry Burden, two years later, constructed a well-shaped plow which was widely popular on account of its light draft. In 1820, in the first recorded dynamometer tests of plows made in New York, his plow had a draft of 250 pounds for a ten-inch furrow to 325 pounds for Jethro Wood's, depth of furrow not stated.

After buying shares and moldboards for his plows for a number of years, Joel Nourse, of Shrewsbury, Mass., and his partners, failed in the manufacture of plows built according to Jefferson's principle. Nourse then cut and hammered from a sheet of lead a moldboard which he believed would overcome the greatest defect in the Jefferson plow — *i.e.*, failure to turn the furrow over at all times. In 1842 he brought out the Eagle No. 2 plow, which was popular for many years. The moldboard was of greater length than on the majority of American plows, and had more twist at the rear than the English and Scotch plows. It also approached more closely than either to straight lines in a longitudinal direction. Without planning for this result, he found that the extra twist of the moldboard pulverized the soil admirably.

Governor Holbrook of Vermont later assisted Nourse in designing plows and devised a system by which, if the longitudinal lines were carefully laid down upon the pattern, the vertical lines were sure to be right, no matter what size or shape of moldboard was desired. By his method straight lines ran from front to rear, and from the sole to the upper parts of moldboard and share. None of the lines was parallel, nor yet radiating from a common centre. A change in the angle formed by any of the transverse lines changed the direction of the vertical lines also. The surface of the moldboard was such that different parts of the furrow slice moved at different

velocities, a fundamental principle involved in pulverization noted by Jethro Tull in his description of the old four-coultered Berkshire plow.

J. Dutcher, of Durham, N. Y., claimed discovery of a valuable principle in relation to the line of draft. He provided his landside with "suction" — *i.e.*, an upward curvature of one half inch maximum from a straight line drawn from point to heel. This allowed the beam of the plow to be set level with the base line. The plow would penetrate hard ground as well as before, when the fore end of the beam was set high, and, the entire sole being more nearly in contact with the bottom of the furrow, the plow ran more steadily than when "running on its nose." He pointed out that the draft line must be straight from the horse's breast to the centre of resistance on the plow, and that the point of hitch on the beam must lie within that line. He condemned the long beams then in use as tending to thrust the hitch forward of the proper line and necessitating an upward inclination of the beam to counteract this tendency. Two feet for hard ground and two feet four inches for mellow he regarded as the extreme distances to which the beam should extend forward of a perpendicular from the point of the share

John Mears, of the firm of Prouty & Mears, observed about 1833 that the irregularity in the running of the plows of that time was caused to a large degree by the fact that the beam was usually set so that the front end lay an inch or two to the right of the plane of the landside produced to that point. This was done to counteract the tendency of soil pressing on the rear of the moldboard to force the plow point away from the land. Mears saw that the centre of resistance lay only a short distance to the right of the plane of the landside, the force required for cutting the vertical wall of the furrow nearly balancing the work of the share and moldboard. He inclined the landside seven degrees toward the land, leaving the beam directly over the point of the share, but parallel throughout

to the landside, this exactly balancing the resistance on either side of the line of draft. The study of the line of draft by these men and others who followed resulted in plows of lighter draft and easier guidance.

Daniel Webster, in 1836, planned and constructed a plow which had little bearing on the development of plows for farm use, but illustrated the possibilities of a single plow bottom

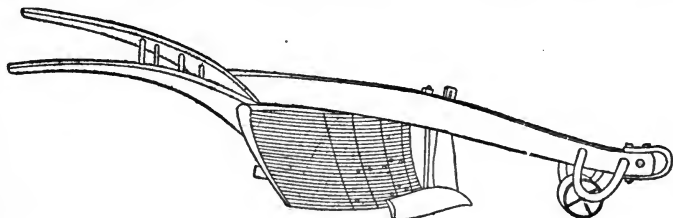

Daniel Webster's plow

in the way of deep tillage. It was 12 feet long, with a 15-inch share, and a moldboard 4 feet long by 28 inches high. The furrow was 12 to 14 inches deep and nearly two feet wide, the moldboard having a spread of 18 inches at the heel and 27 inches at the tip of the wing. It had an iron share and landside forged together, a wooden beam and handles, and a wooden moldboard plated with straps of iron. Webster made the moldboard along Jefferson's lines with certain modifications such as greater relative length and overhang. He believed in deep plowing, and the success of his plow in a brush-covered pasture may be told in his own words: "When I have hold of the handles of my big plow in such a field as this, with four yokes of oxen to pull it through, and hear the roots crack and see the stumps all go under the furrow, out of sight, and observe the clean, mellowed surface of the plowed land, I feel more enthusiasm over my achievement than comes from my encounters in public life in Washington."

In 1852 Samuel A. Knox patented a method of forming a

moldboard on mathematical principles and is given credit for being the first to lay down all the lines of a plow on a plane surface. His plow was of light draft, but pulverized the furrow very little, hence did not meet with the approval of the Eastern plowmen so well as the same type when later presented to prairie farmers.

In order to bring out the existing merits of the plows and ascertain certain principles in design and construction, the New York Agricultural Society in 1850 and again in 1867 held famous trials which provided a fund of information for inventor, maker, and farmer alike. Gould's report of the latter in the "Transactions of the New York Agricultural Society" is believed to be the first attempt at a complete history of plows and a discussion of their principles. A larger part of the foregoing information has been abstracted from this source. Many improvements have been made since then in the materials from which plows are constructed, but changes in the shape have been in detail rather than principle and need not be further reviewed.

Gould does not mention the progress that had taken place in the West in the art of plowmaking, but pioneer inventors had met and solved problems which were as great as had been encountered in the East. The early emigrants to the prairies of Illinois and Iowa found new conditions — tough sod, difficult soils, and larger areas — under which their older plows were hopelessly inefficient.

In the colonial period the cultivated land was largely that which had been cleared of timber. It was generally porous and penetrable, with neither old clay land's tendency to stick and bake, nor the mat of living and dead grass, which, above and below the surface, harassed the pioneer plowmen of the plains. The great variation in the soils of a single New England field made it next to impossible to adjust the plow to the nature of the soil, and as a rule cast iron plows scoured well enough anyhow. Again, farming was hardly on the commer-

cial scale which now prevails in the West — rather the home-spun type, where, as already pointed out, the average farmer raised a variety of products for his own use, with a small surplus to exchange for the few articles of commerce indulged in at that time.

The long, gently curving moldboard, with friction reduced to a minimum, enabled the farmer to uproot the stubborn sod with the limited power at his disposal, and other tillage implements were devised to make up for the deficiencies of the plow as a pulverizer. The firm, tenacious nature of the sod permitted the use of curved wrought iron rods in place of the steel moldboard, and many "prairie sod breakers" of this type are still used. They are slightly cheaper, and give equally good results. As the country grew older, the "timber" soils lost their high content of vegetable matter under the careless methods of farming, and complaints were heard regarding the scouring in the sticky ground. From the very first the prairie sods presented the same problem to the plowmaker.

It is not known who discovered that a high grade of steel would scour under Western conditions, but the first recorded construction of a steel plow took place in Chicago in 1833. John Lane, the builder, took three lengths of steel cut from an old saw to fashion his moldboard, and another for the share. All four were fastened to a frame, or anchor wing, which served as the shin of the plow. For several years he continued to buy up old saws from which to make plows, until he had exhausted the supply. Fortunately, he was finally able to secure from Pittsburg saw blanks of sufficient width so that two were enough for a moldboard, and about 1839 or 1840 he obtained a special width, rolled twelve inches wide, that, as one writer says, "gave quite a boom to the infant industry."

John Deere, a blacksmith at Grand Detour, Ill., built in 1837 three steel plows, one of which is still in existence. More fortunate than Lane, he obtained an old sawmill saw from which to form his one-piece share and moldboard. Two

years later he made ten plows, and their success led him to make greater efforts to secure satisfactory material. After buying abroad for some time the steel which he could not



John Deere's first plow, 1837

obtain in this country either in the desired quality or quantity, he finally secured steel made especially for his purpose. James M. Swank, in his "History of Iron in All Ages," says: "The first slab of plow steel

ever rolled in the United States was rolled by William Woods at the steel works of Jones & Quigg, and shipped to John Deere in Moline, Ill." Deere moved his factory to Moline in 1847, and two years afterward was making ten thousand plows annually. His factory still bears his name, and, as does also the one established by William Parlin at Canton, Ill., in 1842, produces an enormous output of steel plows.

The credit due these men for the development of steel plows must be extended also to John Lane, inventor of soft-centre steel and son of the maker of the first steel plow. On September 16, 1869, he received his patent on a plate consisting of two layers of high carbon steel on either side of a soft centre, a material which proved easy to temper without warping, and resistant to strains in service. In its manufacture a billet of soft steel two inches is placed in a mold six inches square and twelve inches deep. The high carbon steel is then poured on either side simultaneously by hand. Great care must be taken to prevent the molten metal from touching the centre billet until the filling of the mold brings the solid and liquid in contact. Complete fusion takes place, and the block is then rolled to the proper thickness, retaining an equal depth of the three layers. A Mr. Morrison brought out about the same time a steel with a soft backing, which was less easy to temper, and



later a cheaper but rather uncertain process of hard-tempering the outer surface to an equal depth was discovered. Lane's process, which has been generally adopted, has proved worth untold millions to Western farmers in the saving of power, as well as the certainty of being able to plow under what has been regarded as unfavorable conditions.

What Lane's invention was to the tiller of the prairie, James Oliver's was to the farmer of the Eastern States. From the time of Ransome and Stevens efforts had been made to harden the wearing parts, but credit for the practical development of the idea is due to Oliver. He began his experiments at South Bend, Ind., in 1853, received a patent on the chilling process in 1868, and so perfected it near the close of 1873 that his name is still inseparably linked with the chilled plow in all parts of the world. In the making of the chilled castings, iron or low-carbon steel is run into a mold, the front side of which is a metal vessel filled with water. This chills the molten metal quickly, causing the fibre to run perpendicular to the surface, so that the wearing action on the moldboard is like that across the end of a bundle of sticks. The back of the casting runs on sand, hence cools more slowly, is less hard, and is tougher. An annealing and tempering process renders the share and moldboard more resistant to strains. The chilled surface takes a much higher land polish than cast iron, hence will scour in more difficult soils.

The sulky, or wheel, plow has been developed in the last thirty or forty years, fully half of which was spent in work upon the old style two-wheeled plow. In 1843 T. D Bural, of Geneva, N. Y., first used an inclined wheel to reduce the friction of the landside, placing it between the latter and the moldboard. His plow was not a success, but the idea contained the germ of the "staggered" wheel now in common use.

H. Brown, in 1844, combined several plow bases in a gang supported on wheels. E. Goldthwait, in 1851, patented a

fore carriage — *i.e.*, a two-wheeled frame supporting a plow not unlike the usual walking plow — and two years later C. R. Brinckerhoff patented a similar construction. Several patents on gangs, including that of Aaron Smith, preceded the patent issued to M. Furley in 1856 on a sulky plow with one base. Numerous other patents followed rapidly, but the first successful riding plow was a gang plow patented by F. S. Davenport February 9, 1864. During the same year Robert Newton, of Jerseyville, Ill., converted one of these gangs into a three-horse plow, changing the position of the tongue, adding a three-horse evener and a rolling coulter. His plow had a wide sale in the next few years.

A single-bottom sulky plow was patented in 1856 by M. Furley. Gilpin Moore, in 1875, and W. L. Cassaday, the following year, received patents on sulky plows and continued for many years to make improvements. The latter was the first to remove the landside entirely and use a wheel in its place, the wheel running in the angle of the furrow at an inclination of nearly forty-five degrees from the perpendicular. In 1884 G. W. Hunt patented the first of the three-wheeled riding plows that are now universal. One inclined wheel ahead in the old furrow, and one following in the new, "hug" the furrow wall and hold the plow steady without the use of a fixed tongue, thus greatly relieving the strain upon the horses.

Many other inventors since have contributed improvements in detail, but aside from combining sulky plows into gang plows of two or more bottoms no radical innovations have come about since the work of the men already mentioned. Moore, Oliver, and others adapted the shape of the moldboard to countless soil conditions, until several hundred shapes are now made by each of the largest factories. The unit horse-drawn plow once perfected, the combination into gangs has been a much simpler problem. Invention, largely through Americans, has again reached that stage with regard to the

moldboard plow for animal power where it seems impossible to secure greater perfection. American plow-builders are shipping their product by the millions annually to the newly

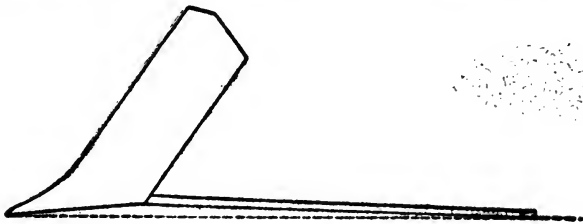

Suction of the plow—landward

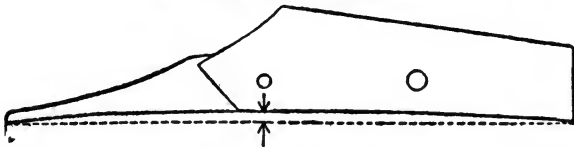

Suction of the plow — downward.

developing fields of Canada, Russia, the Argentine, to Mexico, Spain, Australia, France, England, even to the cradle of the modern plow — Scotland itself.

While the majority of inventors were devoting their attention to the moldboard plow, a few developed the disk plow, largely with the idea of reducing the draft caused by the sliding friction of the moldboard. In this they were only partially successful, if at all, but they succeeded in producing a plow which would work well under extreme conditions. Professor Davidson, of Iowa State College, covers the essential considerations thus: "In soils where the moldboard plow will do good work there is nothing to be gained by the use of the disk plow. The draft is often heavier for the amount of work done and the plow itself is more clumsy than the other form. However, in sticky soils, where the moldboard will not scour, the disk plow can often be made to do good work. Again, in very hard ground, where it is impossible to plow with the mold-

board plow, the disk will work, and apparently with much less draft. The manufacturers of both disk and moldboard plows are now recommending generally the use of the latter for soils where it does good work." This opinion is supported by that of other prominent agricultural engineers, and may be accepted as presenting adequately the adaptation of the two types.

One of the earliest patents in disk plows was granted to M. A. and I. M. Cravath, of Bloomington, Ill. Their plow consisted of three disks, each cutting a narrow strip, and proved that the principle could be applied in practice. It was defective in means for counteracting the side pressure. J. K. Underwood obtained several patents, including one for a three-wheeled frame. D. H. Lane proposed to keep the plow in line with the furrow by a wheel running in the rear of the disk. M. T. Hancock finally succeeded in making the disk plow practical, and it now has a wide popularity in sections where conditions favor its use.

The development of engine gang plows, which was the logical outgrowth of the extension of traction plowing, has largely taken place since the beginning of the twentieth century. The introduction of a new source of motive power involved the plowmaker in new difficulties. The hitching of modern horse plows behind engines resulted in outfits as crude and unwieldy as oxen and the "Bull" plows of a century previous. Fortunately, Yankee invention, sharpened by competition, aided by marvelous manufacturing equipment, and directed by the far-seeing eyes of up-to-date sales and experimental organizations, was quicker to respond to the new need, and in less than a decade the plow has again caught up with the motive power in its state of perfection.

No one man can be given credit for any important step in the development of the engine gang: it was rather the work of many minds, impressed all at once with a new, swift-arising situation. The early types were of inflexible construction,

several plow bottoms held rigidly in a single frame. These were more compact, each gang cutting three to six furrows, but, besides being heavy to throw out of the ground, they failed to adapt themselves to uneven surfaces. Combination of these units into loads for the largest engines presented difficulties in the way of suitable hitches. Steam-lift plows solved the one difficulty, and were even more compact. They were too expensive, however, and have quite largely given way to hand-lift types embodying their compactness, but much more simple in construction. To-day the latter stand representative of the highest type of agricultural implement.

From the war club of the first true agriculturist to the steel plow of to-day is a step which embraces all the history of civilization. From development of the human muscle, which gave power to the Egyptian sarcle, to the mighty engines which draw our modern gang plow is a far wider step. No less is the gap between the plow factory of to-day and the laborious task of the savage who first shaped a pointed weapon by rubbing one stick upon another or a stone. The history of man in all ages records the utilization of the highest opportunities within his grasp. The plow has advanced only as the accumulation of knowledge has taught what should be its shape, as instruments and materials for shaping it have developed, and as blind superstition and ignorant prejudice have withdrawn their opposition to progress. The sarcle, refined into the form still in use, affords a subject for a painting like Millet's "The Spaders," or "The Man with the Hoe." In a modern commonwealth the ancient breast plow, driven by a weary toiler of the soil, still bears occasional aid to the sustenance of mankind. But these are only the exceptional, the enforced, variations from the rule. The modern plow has wrested an abundance from the soil. Animals harnessed to it have freed the peasant from the heaviest of all tasks, and given him leisure to advance in knowledge. The world now rests in confident anticipation of the farm's certain surplus. Civil-

zation and the plow have gone together, and whatever advancement of humankind we may look forward to will surely be paralleled by perfection now unattained in that noblest of instruments. Fitting it is that the United States Government should place the plow prominently on the great seal of its Department of Agriculture.

## XVI

### PLOWS FOR ANIMAL POWER

ONLY a small percentage of all the thousands of patented plow forms remain in use, yet the variations in modern plows are so great as to render a complete classification next to impossible. The essential features, however, are well defined. Plows for use with animal power may first be divided into walking and riding, the latter including sulky and gang plows. The single moldboard plow is the most common, though double moldboard, reversible, and two-way plows are made for special purposes. Cast iron or steel, Bessemer steel, soft centre steel, chilled iron, wrought steel, malleable iron, and wood all enter into the construction, and various attachments added to the essential features multiply the possible combinations.

The features of the single moldboard are landside, frog, brace, beam, clevis, handles, and coulter. The *share* forms the horizontal cutting edge and joins the moldboard to form the "shin," which cuts the land vertically. The *point* is the part which first enters the ground, and the *heel* or *wing* is the outer extremity of the cutting edge. The share is sometimes welded to the landside bar and called a "bar" share. Otherwise it is called a "slip" share. The "sock" share, a very old style which is still used largely on English and Scotch models, fits over a tongue on the lower end of the moldboard. One type is known as a "slip nose" or "cutter" share, in which the share and shin are cast in one piece. This protects the moldboard, and when worn may be renewed at less cost than the latter.

A separate shin piece is provided on some types. The share and landside are often made of cast iron or soft, natural temper steel on the cheaper plows, but often of hardened soft-centre

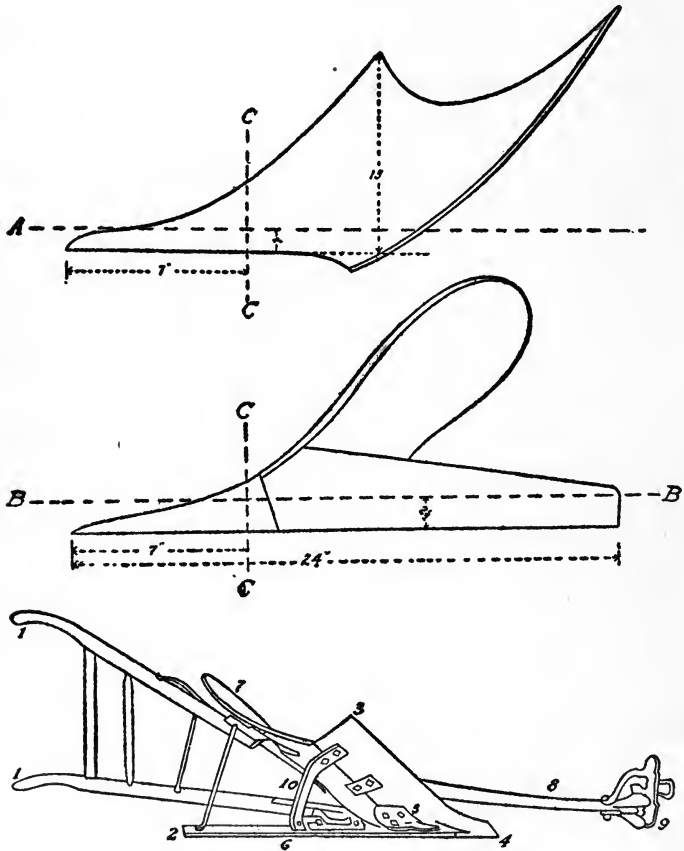

Parts of a plow

or chilled steel. The cast share is more apt to break under a strain, but wears longer. It is often used with a steel mold-board in sandy soils, combining the cheapness and wearing



qualities of the former with the lightness and elasticity of the latter. Some share points, as well as the shin of the moldboard and the heel of the landside, are reinforced with extra material on account of the heavy wear on those places. To avoid the rapid narrowing of the furrow as the heel wears away some shares are given a truncated (blunt) heel, the edge of which is almost parallel to the landside.

The *moldboard* receives the furrow from the share and turns it. Its shape has been and will be discussed elsewhere. The *landside* counteracts the side pressure caused by the cutting and turning of the furrow. Most plows are given "suction"—*i.e.*, the lower face of the landside is raised in the middle from a straight line drawn from point to heel. This is to cause the plow to enter the soil easily and run at the proper depth in spite of the lift by the traces on the end of the beam. The suction is usually about one eighth of an inch, being increased for hard ground and often dispensed with entirely in light soils.

The cast shoe, or heel plate, often used under a steel landside saves wear and affords the necessary bearing surface. It is adjustable as to width, as required for different soils, and for depth, so that as the plow point wears off the heel can be raised to keep the plow in the ground. In addition to the downward suction the landside is usually made concave by turning the point of the share outward from one eighth to three eighths of an inch. This is for the purpose of making the plow "take land"—*i.e.*, cut full width. The effect of these deviations from a straight line between point and heel is to increase the draft, as more power must be applied to overcome the tendency of the plow to run toward the land and deeper. The plow runs less steadily, the motion being a succession of jumps, the effect of which may be seen on the bottom of the furrow, and the presence of concavity on either face of the landside is really a confession of wrong adjustment to the plow. Prof. J. W. Sanborn, who, next to Gould, has probably made more draft tests of plows than any other man, found the dipping of the

point on the base to cause about 9 per cent. increase in draft and the angling of the point on the landside about 16 per cent. increase. Mr. Sanborn made trials of the same plow before and after changing the shape, also of a new plow from which the angles had been removed.

The lessening of draft by slanting the share and shin of the plow has caused the opinion that inclining the landside also reduces the draft by giving a drawing cut. The fallacy of this is apparent when it is remembered that angles in but two planes are possible to the line of direction. The plow meets the earth squarely and the beveling of the landside does not tend to reduce the draft. It does, however, tend to equalize the motion of the plow, as shown in Mears's invention, and it has the further effect of giving a diamond-shaped furrow which will topple over of its own weight when the width and breadth of a furrow are nearly equal. Ox plows of the present day are also made with beveled landside, because the slow motion of the oxen does not give enough velocity to the furrow to throw it over without an extreme twist to the moldboard. Landsides are of different heights, the highest being used for stubble plows, on account of the depth of furrow.

The *frog* is the foundation to which the landside, share, and moldboard are fastened. It may be made of cast iron or wrought steel. Connection may be by removable bolts and rivets, or a solid weld. The *brace* separates the landside and share and holds them rigidly. The *beam* connects the plow bottom with the hitch. Wooden beams are rapidly giving way to steel, owing to the scarcity of suitable timber. The wooden beam is lighter, and while more easily broken than steel is more elastic and will spring back into place after a severe strain, so that the adjustment of the plow will not be disturbed. They are more cumbersome, however, and at a disadvantage in trashy ground. The more expensive steel beams are composed of 60 to 80 point carbon steel as compared to 30 or 40 point for the cheaper beams. The lower

grade is cheaper to manufacture, not only because the cost of materials is less but because more labor and equipment are required for handling the higher carbon steel. The softer metal has a coarse grain which becomes fractured if a beam is sprung. Even if straightened it will easily bend again at the same point. The higher quality of steel is more elastic and can be restored again to its original condition.

A low, rather straight beam, curved to join the plow bottom, is used on prairie breakers. On stubble plows the beam is usually higher and has greater curvature, so as to clear the trash and weeds. For stubble plowing in very hard ground a high beam with a goose neck is necessary to keep the plow in the ground. On wooden beam plows and on some gang plows where a perfectly straight beam is used a cast standard sometimes connects the beam with the share, moldboard, and landside, taking the place of the frog. The higher the beam the greater the possible adjustment as to depth and the greater the ease with which a rolling coulter can be used.

The *clevis*, or *bridle*, as it was formerly called, is provided for connecting the plow beam with the eveners. It is made so that the plow may be adjusted for depth and width simply by changing the position of the pins in the clevis. The *handles*, which are usually fastened to the beam and the moldboard or the frog, are provided for the use of the plowman in lifting and guiding the plow. The modern plow, however, should run easily with very little guiding by the operator. Handles are usually of wood, although steel is being used to an increasing extent. The *coulter*, or cutter, is provided to aid in severing the furrow slice from the land. It may be fastened to the landside of the share, extending upward out of the ground, in which case it is known as a *fin* coulter. This type is quite efficient for breaking sod, but much less so for stubble plowing. The coulter may extend downward from the plow beam, the other end either fastened to the plowshare or left free. A plow thus rigged with *standing* cutter requires special knowledge

and care in order to secure the best results. This is because the set of the cutter alone may be made to ruin the work of the plow by guiding it to take too much or too little land in spite of any change of hitch at the clevis. The rule is to set a standing coulter as if it had no thickness. Whenever the plowman finds that it is leading the plow, which will be indicated by the plow's swinging climbing, and running unsteadily, he will find the remedy by adjusting it to or from the land, as required, by means of wedges under the shank. The rolling coulter is usually connected to the plow beam by a swivel shank and socket, being kept in line by the resistance of the soil.

A form of coulter known as the *jointer* consists of a miniature plow which is adjusted to the beam forward of the point of the share. This cuts a small ribbon-like furrow which is thrown in the bottom of the larger one and thus does away with the fringe of grass or weeds which might otherwise project above the plowed field. Where the soil is apt to drift, as on the Great Plains, this fringe is desirable, as it catches and holds the soil and snow. In the Eastern and Central States, where these conditions do not exist, the jointer is popular because of the burying of all vegetation, and because it enables a rather deep furrow to be completely inverted.

Among the useful attachments to plows is the harrow attachment, which may be attached to the rear and usually to the right of the plows on sulky and gang types. It may be composed of solid disks, knives, or propeller-like sections. By pulverizing the soil immediately it requires little power as compared with the harrowing done later. It also checks any loss of moisture by at once covering the soil with a dust mulch. Another is the fore carriage for walking plows adopted from France. This consists of a furrow wheel, a ground wheel of somewhat less diameter, a connecting crossbar, and means whereby the depth can be adjusted. This takes the place of the gang wheel and to some extent aids in regulating the width

of furrow. The plow is made easier to guide in hard ground, with more even plowing as a result.

The plow bottom is composed of the moldboard, share, brace, frog, and landside. Stubble and breaker bottoms are usually made interchangeable, so that on sulky and gang plows the same frame may be used for different purposes. Riding plows have usually three wheels, the larger of which runs upon the unplowed ground. There are two wheels with inclined axles, one running in the old and one in the new furrow. These take the place of the landside in guiding the plow. The plow beam is attached to the frame by means of bails, and suitable levers are provided to adjust the depth of plowing. The width is adjusted by a lever which changes the direction of the furrow wheels. Nearly all sulky and gang plows are provided with frames and nearly all have tongues by means of which the plow can be steered and backed.

Gang plows are simply combinations of sulky plows, although the sulky plow usually has a wider bottom than the gang. Sixteen inches for the sulky plow and fourteen inches for the gang are the most common, although twelve-inch and eighteen-inch bottoms are to be had. The variation in plow shapes has already been touched upon. The moldboard is of course the most important source of variation. The short, steep, sharply curving moldboard is used in the stubble plow, and the low, narrow, gently curving type for the prairie breaker. The intermediate plows are adapted to different soils and different conditions. One experienced plow designer says that with the exception of the necessary graduation from one extreme to the other the minor differences in shape are due almost entirely to local whims. To a large extent these differences are recognized by the larger manufacturers. In many sections, however, farmers persistently cling to some shape which by reason of its extreme localization is not profitable for the large manufacturer to dally with. This accounts for the existence in many out of way places of small plow

factories or even an occasional old-time plowwright. Plows with wooden moldboards are still made in various parts of the South.

The designer, before referred to, says that it is a curious thing in plow adaptation that where one shape will work admirably one season it will not work at all the next year under apparently the same conditions. There will be a vast difference in scouring, with nothing to account for it except that the action of the winter may produce physical and chemical changes in the soil to affect the efficiency of the plow.

## XVII

### PLOWS FOR MECHANICAL POWER

**T**HE ideal engine gang plow has not as yet been developed, but one or more of the essentials have been realized in every principal type yet offered. It must be compact, strong, durable, simple, easily manipulated, cheap, light of draft, and, above all, efficient. Analyzed as a plow for mechanical power, the horse plow is desirable only on account of its cheapness and light draft.

In the early stages of steam plowing, however, devices for hitching horse plows to the engine necessarily received a great deal of attention. Besides the cumbersome webs of chain and cable which were developed, some so-called plow hitches were brought out. One of these which had a considerable sale was a combination of tender and plow frame. A shallow, triangular water tank was hitched with the base toward the engine, and the horse plows were attached to the rear or oblique side of the tank. The development of plowing engines with larger tank capacity and the introduction of more suitable plows rendered this makeshift unnecessary.

Practically all traction plowing is now done with specially designed engine gang plows. Both disk and moldboard types are made in large numbers. They present a great variation in size and in the features that distinguish them from horse plows. In the main they are very satisfactory, and to their development, quite as much as to the improvement in tractors, may be attributed the rapid advance during the decade in plowing by mechanical power.

Moldboard engine gangs may be divided into hand-lift and power-lift types. Those of the hand-lift type may again be divided in two general classes:

(1) With bottoms combined into a rigid frame, which is raised and lowered as unit by one lever.

(2) With bottoms attached either singly or in pairs to one independent frame, each bottom or pair of bottoms being controlled by a separate lever.

The former are known as "solid" gangs and the latter as "flexible hitch" gangs. The term "flexible," however, is used also to distinguish from a rigid frame of the latter type one which is jointed to adapt it to work in uneven ground. Engine gang plows, especially the flexible types, are usually more efficient than horse plows. The point of hitch is lower, and the distance from the point of hitch to the centre of resistance greater. The line of draft is thus more nearly parallel with the base line and there is less loss of power through the opposition of forces. From the point of hitch on the drawbar to the centre of resistance of an engine gang plow is frequently from twelve to eighteen feet, with a descent of only eighteen to twenty inches. From the point of a horse's shoulder to the ground is about fifty inches, and from that point to the centre of resistance only eleven or twelve feet; hence there is greater tendency to lift the point of the plow from its true position. This tendency must be overcome by giving it, either through suction or the curvature of the beam, a natural inclination to run into the ground. The more nearly the centre of resistance moves along the line of draft the more easily the plow will "swim," and the fewer will be the undulations left on the bottom of the furrow from jumping. Unfortunately, the majority of engine gang, plowmakers seem to have overlooked this point and simply transferred the horse-plow bottom to the engine gang without correcting the unnatural, but perhaps necessary, curvature of beam and landside.



Where a number of furrows are plowed at once, as with the engine gang, they are more uniform. Only the outside furrow will vary in width provided the plows are given and hold their proper adjustment. The bottoms tend to hold each other in line, especially if provided with buffers which allow free play vertically and but a slight amount sidewise. Frequently, however, the connection between beam and plow frame is weak, and where no other means is provided for preserving the alignment, the furrows cut by the same sized bottoms will vary several inches in width. The depth of furrow should be, and usually is, quite constant, with the flexible plows; hence a more uniform seed bed is secured than where several rounds are made with horse plows in covering the same ground. Especially is this true if several teamsters, each with his own idea of plowing, are working in the same field.

Engine plows are made heavier and stronger in beam and standard than those for horses, since an engine will not, of itself, stop in time to avert damage to the plows in case of a solid obstruction. The bulk of the extra weight lies in the frame, however, which must span a wider interval, yet remain absolutely rigid between points of support. A common walking plow weighs about 125 lbs., a sulky plow about 375 lbs., and a two-furrow horse gang about 325 lbs., per bottom. A solid engine gang weighs 350 to 450 lbs. per bottom, and the large flexible hitch gangs 600 to 800 lbs. The additional weight of frame is carried on rather small, though broad, wheels, which largely overcome the advantage secured in engine gang by changing the line of draft.

Something of the added cost of constructing engine plows is shown by the following relative prices: A walking plow costs from \$10 to \$16; and a sulky, \$30 to \$35. A two-furrow gang costs from \$25 to \$30 per bottom; a disk-engine gang plow about \$30; a solid moldboard engine gang about \$40; a large flexible hitch gang about \$75; and a steam-lift plow \$100 to \$125 per bottom.

## RIGID GANGS

The solid gang is ordinarily made with from three to six bottoms, with provision for removing one bottom to adapt the plow to harder service. The width of cut is from twelve to sixteen inches for each share, fourteen inches being the most common. The largest size of bottom is often chosen on account of greater clearance between bottoms, fewer beams, etc., and the less time required to change shares for a given total width of furrow. Plows of this type usually consist of an open framework, which is made up of the beams, braces, and tie bars; three or four carrying wheels, the rear one of which is sometimes replaced by a shoe; three or four levers for regulating the depth, steering and lifting the plow; the plow bottoms; and either rolling or fine coulter. Sometimes a seat attachment may be included, also a footboard for the operator. More often, however, he is obliged to walk behind the plows to manipulate the levers.

Right-hand plows are universal. The bottoms are set obliquely from right to left to afford clearance between the landside of one and the share of the next. The rear wheel or shoe on a rigid gang usually runs in the last furrow next the land and the right-hand forward wheel in the last furrow of the previous round. The furrow wheels may be inclined, or staggered, to offset side thrust, and all the wheels are sometimes flanged to prevent side slippage. Where four wheels are used the weight is more evenly distributed than on three, but in uneven ground four points of contact more frequently disturb the evenness of depth. The depth may be regulated by an axle bent in the form of a crank or by raising and lowering the frame on an upright extension of the axle. The levers extend to the rear, where no running board is provided. They are usually of steel, made long, to facilitate lifting. Lifting springs also aid in overcoming the weight. For transport,

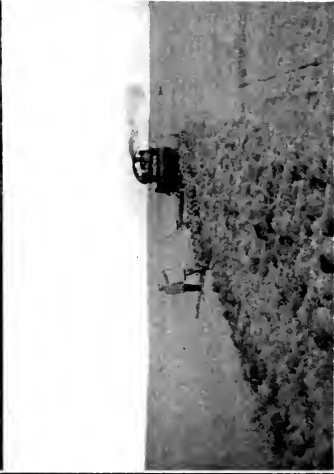
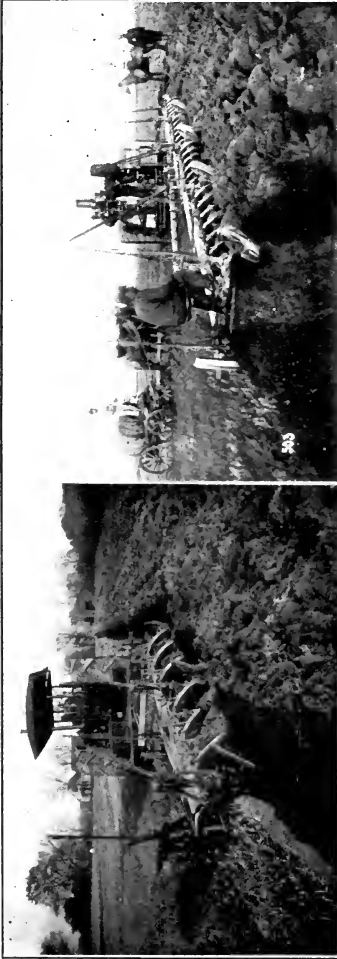

**ENGINE GANG PLOWS**

- A small disk gang
- A spring trip gang plow
- A large gang plow in Russia
- A Stockton gang plow with a caterpillar tractor



the plow points may be raised from five to twelve inches on different makes. Castered wheels on one type make it easily possible to trail several sections one behind the other for passage through narrow openings.

Since in these rigid gangs the bottoms are held rigidly, irregularities of the ground surface cause the furrows to be of uneven depth, some plows running deep and others skimming or skipping entirely. An obstruction before one plow lifts several out at one time, and an accident to one may put the entire set out of commission. For these reasons the smaller sizes of three to five bottoms are more popular than the larger, even though the latter are more compact. On one type each bottom is held in place by a device which allows it to be thrown upward without damage in case it strikes a stone or root. While in service, however, the bottoms are prevented from adapting themselves to uneven surfaces.

For small tractors solid gangs of lighter construction and adapted to either horse or engine hitch are often used singly. For larger engines it is necessary to combine several plow units. Cables, rods, and chains are used to hitch them behind the engines, the hitch usually being devised to fit the particular case in hand. Where an engine is not equipped with a wide plowing drawbar, it is necessary to attach the cables or chains to a crossbar and thus hitch to the centre of the engine. Since the wheels of each gang must clear those of the one preceding, the combination of from one to four units renders the outfit long and unwieldy. This is especially true if, for the sake of flexibility, small gangs are used. The long cables are apt to become fouled in turning to the right, and in plowing around corners strips between the gangs are usually left unplowed. Castered wheels and a special coupling device on one type are claimed to render the outfit capable of turning in either direction and plowing perfectly around corners, the total width of cut being reduced of course on the turn.

The practice of combining plow bottoms in a rigid gang has

now been practically discarded, especially for large power units. On the Pacific Coast, however, the large ranchers still use many Stockton gangs, these being cheap and fairly effective modifications of the moldboard gangs. On a triangular wooden frame are fixed from three to eight rigid iron standards, each holding a reversible plow shape. Each plow cuts a furrow eight to ten inches wide and of shallow depth, stirring, rather than turning, the soil. This plow was originally designed as a cultivator, but has been adopted as an engine gang plow by large land owners who adhere to the exploitive type of farming. With the large engines used in that section, a strip thirty to forty feet wide is often plowed at one time and as high as ninety to one hundred acres skimmed in one day. The resulting outfits are unwieldy, and will undoubtedly give way also to those using larger and more compact plow units, with the capacity for deeper and better plowing.

#### FLEXIBLE ENGINE GANGS

The flexible hitch moldboard gangs range in size from four to sixteen bottoms. The smallest frames are made lighter for use with small tractors, and some are arranged to use from four to six bottoms according to the nature of the soil. The sixteen-bottom size is made only for extremely light soils. Ordinarily the frames are made to accommodate from six to twelve bottoms, with an extension providing for one or two more if desired.

The hand-lift gangs consist of frame, carrying wheels, platform, plow bottoms, levers, hitches, gauge wheels, and coulters. The frame is triangular in general outline, built up of steel parts, which are solidly trussed and riveted into a rigid whole. The large gangs are sometimes made with flexible frames, which adapt themselves to uneven ground. On several of these the frame is made up of two sections, each of which may be converted into a separate frame for use with a smaller engine.

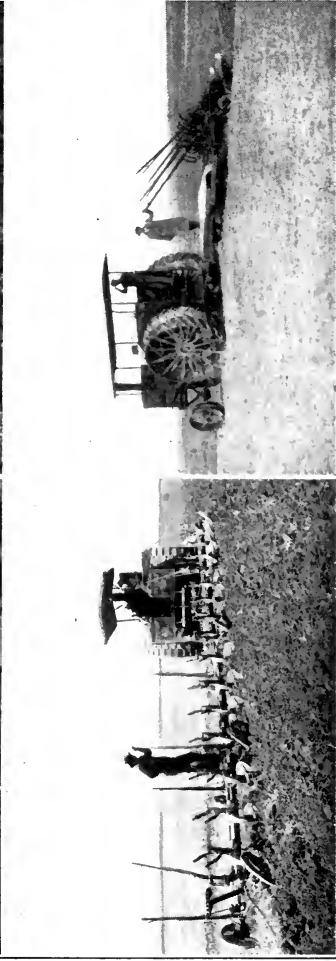
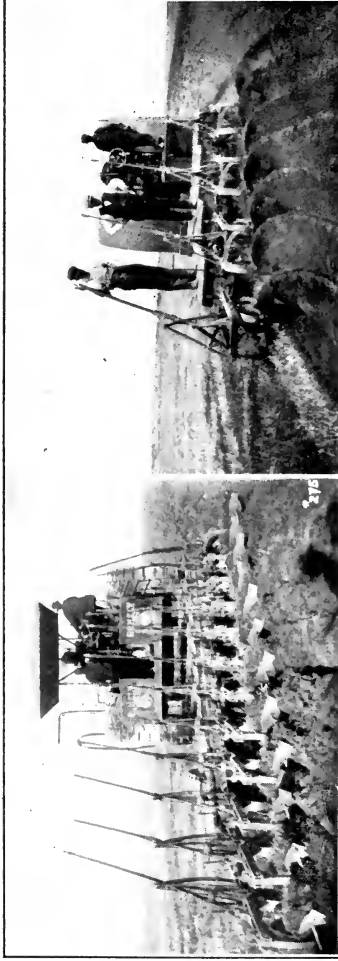

**ENGINE DRAWN PLOWS ON PRAIRIE SOD**

A single hitch type with twelve "breaker bottoms" behind a 36 horse-power steam engine

An eight furrow mogul plow with a single hitch to a gasoline tractor





A solid wooden platform, usually laid on in sections, covers the frame and affords ample room for the operator, a toolbox and miscellaneous supplies. Usually it extends far enough forward so one may step to it from the engine.

The carrying wheels are about 25 inches in diameter, with tires from 6 to 8 inches wide. In some types three wheels are used, one near each point of the triangle. On others four are used, two on either side. In this case one wheel on the right side follows the frame. The objection already mentioned as to four points of contact is perhaps less forcible in a flexible hitch plow, but in uneven ground the running of the plows is affected nevertheless. One three-wheeled type has a wheel at the rear corner, one on the right side behind the oblique tie bar, and one in the centre in front, thus practically reversing the usual triangle. The front wheels on nearly all types are castered to facilitate turning, and in one case all four are pivoted. One plow has two caster-wheels on the left-hand side, connected with a steering lever. By this means the plow can be turned in less radius than the engine and backed into any desired position with the help of a stiff pushbar. For breaking in rough ground long skids are sometimes used advantageously in place of wheels as they cause the frame to run more nearly level.

The shares and moldboards vary according to the soil in which they are to be used, but depart little or none at all from horse-plow shapes. This accounts largely for the adoption of a low speed of travel on plowing tractors. The beams are longer than on horse plows, in order to give the clearance necessary in trashy ground. One type, especially constructed as a general purpose plow, combines a long beam, a high standard, and no landside, minimizing the danger of choking. For breaking sod the beam might be set quite low without difficulty from choking, but this interferes with the use of a rolling coulter. For stubble plowing and "backsetting" (turning back a layer of sod with an extra inch or so of dirt on top of it) the high

beam and rolling coulter are essential. Otherwise the loose trash and sod will gather ahead of the shin and throw the plow out of the ground.

The beam may be arched and connected directly to the frog, or straight, in which case a heavy casting usually serves as a standard. The casting is shaped so as to form, with the straight beam, a curved throat that will clean easily. If broken it may be replaced by any one, and the straight beam, if bent, may have its alignment restored by any blacksmith. A sprung beam will destroy the adjustment of the plow, and without the factory equipment it is practically impossible to restore a curved beam to its original shape. These conditions have led to the adoption of the straight beam on most plows of this type. One plow has provision for replacing one of the bolts connecting the beam and standard with a wooden pin. Where solid obstructions are met, the breaking of the pin prevents damage to the plow bottom. In straight-beam plows a double beam is customary, the two bars being spread apart in front to give as wide a hitch as possible and thus brace the beam against side strains.

The bottoms are now commonly hitched independently or arranged in independent pairs, thus being free to follow the irregularities of the ground. When the plows are hitched singly they follow the ground more closely than those in pairs. They require quicker work at the levers at the end of the field, but with the same care will leave the headland more even. One type has bottoms hitched independently and raised in pairs. The single-hitch plows have each a trifle more weight than the double hitch to keep them in the ground, but have a narrower space between clevises at the point of hitch hence are more apt to dodge or "wing"—*i.e.*, tilt to one side. The plows tend to balance each other in the double-hitch type. The single-bottom plow is less seriously affected by an accident to one unit. All units, single or double, of the same make, are interchangeable, save perhaps where one or more of the beams

straddles a carrying wheel; hence the damaged part may easily be replaced by an extra bottom or by moving the rear one into its place. In the latter case, the gang is complete, lacking only one furrow. For ground of varying hardness the single-hitch plow offers the nicer adjustment of load to power, though a single-bottom attachment is now provided by means of which the double-hitch gang is made more adjustable. Either is far more adaptable than the solid gang of three or four bottoms, and much more compact in sizes for large tractors.

The long lifting levers project forward, and are controlled from the platform. Springs aid the operator in lifting. One plow has adjustments whereby all the levers may be focused near the centre of the platform, saving steps in handling. The gang is nearly always hitched to the engine by chains, either crossed or straight, considerable adjustment being provided. This adapts it to either a high or low drawbar, and brings the plows, if necessary, to the right of the engine centre, so that the tractor wheels need not travel on plowed ground. The attachment of beam to frame needs to be adjustable as to depth only, since the engine hitch controls the width of the outside furrow and all others are uniform. A bolt and upright clevises are common, also various spring hitches. One of the latter releases a pair of bottoms in case of a solid obstruction. Another allows the plow to be wrenched sidewise without springing the beam, while in case of a solid obstruction the gauge wheel is drawn forward and the plow is lifted until the strain is released. For the double-bottom hitch a separate clevis is provided for each beam.

The depth of plowing is regulated by the lifting levers, ratchets, and gauge wheels, as well as by the height of the hitch to the plow frame. Adjustable stops attached to the ratchets enable the plowman to return the plows quickly to the proper depth after lifting at the headland or elsewhere. On straight-beam plows the adjustment for suction is usually by means of a set screw, which changes the angle between beam

and standard. A set screw at the fore end of the beam also secures this suction, but at the same time lifts the heel of the share and causes it to cut at less depth than the point. Set screws are commonly used on the fore end of the beams to secure parallel alignment and to level up the bottoms. One recent design has a device by which the sole of the plow is claimed to be kept level at all depths.

The depth or gauge wheel is a vital point in the design of the plow for efficiency. It acts as a fulcrum for the lifting of the plow and carries the weight of one or two bottoms in moving from place to place. It should be large, so that minor irregularities of the surface will not be transmitted to the furrow. This is particularly desirable in backsetting. At the same time the wheel should be so attached as to allow deep plowing in stubble. It should be located so as not to twist the beam and cause one side of the furrow to be deeper than the other. It should protect the point of the share. It should not interfere with the rolling coulter, which by common consent is placed just to the left of the shin of the plow, and just high enough to clear the shin in swinging. It must not clog up with trash and dirt.

The kind and position of gauge wheel best complying with these essentials is an open question. The solid cast wheel without flanges is successful in avoiding trash. The cast-iron wheel is used on a few types, being kept in line by earth resistance. Its greatest advantage lies in the fact that in turning or on striking uneven surfaces it is free to swing and follow without skidding. This relieves the twisting strain on the beam caused by the fixed wheel when bearing heavily on one edge of its rim. On the other hand, with both coulter and depth wheel cast-iron, interference is more likely.

If the depth wheel is placed directly under a beam of ordinary clearance, or between two closely connected bars of a straight-beam plow, either it must be too small for general work or it cannot be raised high enough for deep plowing. A height of beam of from twenty to twenty-two and one half

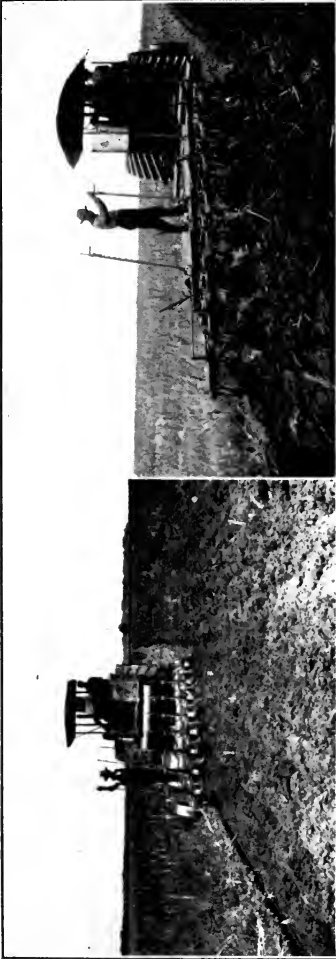

A gang without landsides  
Rigid gang for small tractor



HAND LIFT ENGINE PLOWS WORKING IN STUBBLE'  
Single or double hitch gang  
Rigid units coupled for a long tractor



inches is provided on the present plows, and practice has shown that gauge wheels should be at least twelve, preferably fourteen or sixteen, inches in diameter. Some allowance must be made for hummocks; hence this construction is apt to limit the depth, except in breaking. If placed far to one side of the beam to secure greater depth, or too far forward in order to clear the coulter, it fails to protect the point of the plow. In the forward position the shortening of the radius between it and the hitch increases the difference in elevation between point and heel of share and causes steps between one furrow and the next. This is generally objected to by prairie farmers, though, as previously noted, a truncated furrow is desired by Scotch farmers as being sharper in outline. A more serious objection is that in the advanced position the wheel exaggerates irregularities of the surface, and the sole of the furrow is uneven. Moreover, with the added distance between the centre of resistance and the gauge wheel, the pressure of the latter on the ground is greatly increased, together with the draft.

On the double-hitch type a fixed gauge wheel is placed between the plows to the side of one point and considerably ahead of the other. While this permits of high lift and deep plowing, it does not offer equal protection to both plows. Not being placed in line between the two centres of resistance, it acts as a fulcrum for two lever arms of unequal length, and subjects the beams to severe twisting strains. On the single-hitch plows a wheel set too far to one side of the landside plane has a similar effect. Granting that the rolling coulter's position just above and to left of the plow point allows of little variation, the most practical position for the gauge wheel seems to be as little to the right of the centre of resistance as is necessary for clearing the beam in deep plowing, and as nearly opposite the point of the share as will allow trash to pass freely. It has even been suggested that the coulter and depth wheel might be combined to advantage, the former to consist of a sharp flange attached to the side of the wheel, which in this

case would run directly in front of the plow point. The idea would of course be impracticable for travelling on hard or sticky ground, but it illustrates well the conflicting requirements.

#### STEAM-LIFT PLOWS

Steam-lift plows differ from the large hand-lift gangs in that, in place of a platform and lifting levers, they are equipped with steam cylinders for lifting the plows. Steam is fed from the engine through flexible connections and the plow may be controlled by the engineer without his leaving the cab. From four to six plows are lifted by each cylinder, which operates a boom attached by short chains to the plows. Some types can be backed into position for turning a square corner by means of a steering wheel connected by crossed cables with the front axle of the engine. If one of the enginemen can be spared occasionally to look after the plows in case of trouble, the plowman may be dispensed with entirely. Owing to the added cost of manufacture, the use of the steam-lift feature has been confined to the larger sizes of from eight to twelve bottoms. The steam-lift plow uses considerably more coal and water, is more complicated than the hand-lift, takes longer to attach and detach, and exposes operators to the danger of being burned on hot steam pipes. With the coming of the large hand-lift gang several manufacturers abandoned the steam-lift feature, but various types of power-lift plows, including steam-lift, are constantly being brought forth with a view to reducing the labor of attendants. A simple and inexpensive device which would eliminate the plow attendant is demanded by the trade, especially in the sections where small tractors prove the most useful.

#### DISK-ENGINE PLOWS

Disk-engine gangs are made in sizes of from three to twelve disks. The smaller sizes lack compactness, and the larger



are not well adapted to uneven ground. The disk gang in itself is necessarily rigid, since any vibration of the frame under load gives the plows a jumping motion which results in uneven plowing. The larger gangs, in addition to lacking in flexibility, fail also in the other extreme, it being impossible to produce a wide frame of the necessary rigidity without undue weight. Furthermore, the absence of the landside makes it necessary for the carrying wheels of the disk plow to counteract all the side pressure of the soil. This is excessive where a large number of disks is carried upon one frame, and the rear wheel must be weighted heavily to keep the plow in the ground. The medium sizes of from four to seven disks are now more popular than either extreme, presenting a compromise between compactness, flexibility, and ease of steering. They are usually capable of variation in the number of disks and the width of cut per disk. For difficult soils one or two more disks can be added without changing the total width of cut. Each disk then cuts a narrower furrow, and has better penetration. The twenty-four-inch disk is most frequently used, though for sandy soil a size two inches larger is popular on account of its longer life.

In construction the disk gang is very much like the solid moldboard gang. In fact, one fairly successful combination has been offered, either disks or moldboards, or both, being supplied with the frame. The solid frame is open to the same objections as the solid moldboard type, and presents the same problems as to hitching and the securing of uniform depth and quality of plowing. The frame is necessarily heavier and stronger than on horse plows and the wheels are usually cast very heavy, a single wheel weighing as high as 225 pounds for extremely hard ground. The greater number of makers use inclined furrow wheels to take part of the pressure off the land wheels. Casters wheels on most makes permit the gang to follow the engine closely in either direction, provided the method of hitch will permit.

The levers are like those of the solid moldboard gang in appearance and function. On some gangs the angle of the disk to the line of draft is open to adjustment. It is claimed that if the disk be set so the beveled face on the rear of the cutting edge is level at the bottom of the furrow and perpendicular at the surface of the ground the disks will run practically without side draft. In addition to setting the disks closer together, a less abrupt angle can be used to secure better penetration. For trashy ground the disk may be set to have a coulter-like effect, thus cutting and burying the vegetation more satisfactorily. A running-board and seat may be provided. The latter is usually located at the rear, as the weight of the driver aids in holding the plows in line. Weight boxes and extra weights are often provided at the rear of each gang.

Castings serve to hold the disks to the frame. The disk may have a shaft through the centre, with a bearing at either end, or an axle attached to the rear, or convex, surface only. In either case the bearing is long, well lubricated, and often chilled, as the disk must be kept permanently in perfect alignment. Ball bearings to receive the end thrust are a valuable feature. Scrapers are necessary to clean the disks, and they aid in turning the soil. They are often given a moldboard curvature to accomplish the latter, and one maker states that the successful turning of the soil depends more on the size and adjustment of the scraper than on any other part of the disk plow.

The hitch to the engine is by the same means as used on the solid moldboard gangs. However, it must be put close to the right side of the gang in order to overcome the latter's tendency to crowd to the left and jump out of the furrow.

The centre of resistance, especially on outfits of one or two small gangs, is therefore to the right of the centre of the engine, one disk-plow manufacturer stating that three fourths of the load is on the right drive-wheel. Greater difficulty in steering and unequal strain on the engine are the results.

Lengthening the chain between the engine and the rear of the gant is one common method of changing the angle of the disks.

With twenty-four-inch disks, furrows from four to eight inches deep and eight to twelve inches wide may be cut. One prominent designer recommends plowing furrows not less than five or six inches deep and not over eight inches, preferably seven, wide. The deeper the furrow the less prominent the "hogbacks" left on the surface, and at a depth of six inches a disk cutting not over seven inches wide will break out the triangular space between it and the next disk and leave the bottom of the furrow practically level. As a rule, however, the average user cuts nine or ten inches with each disk, and many not over four inches deep in the centre of the furrow. In consequence, while more ground is covered, a seed bed of uneven depth is formed.

Different makes of disk plows vary considerably in strength and durability. The frame must be very well braced, and the castings heavy. Even with the best construction, simplicity brings the cost low as compared with the best moldboard gangs. If the disks are properly set and held in place, breakage is much less frequent than where some play is allowed, and the disks are to some extent self-sharpening. A twenty-four-inch disk has nearly four times the cutting edge of a fourteen-inch share, and being thinner stays sharp longer. The disk plow rolls over obstructions instead of catching. These items greatly reduce the cost of repairs, in which should be included sharpening, as compared with moldboard plows.

The common practice with disk plows is to plow a continuous furrow around the field without lifting the plows. As the disks seldom choke up with trash and do not require frequent sharpening, lost time on account of the plows is less serious. On the other hand, larger triangles at the corners of the field are usually left to be plowed out with horses. In rounding the corners unplowed patches are apt to be left between strips, necessitating extra trips between corner and centre to finish the field.

The disk is essentially a pulverizer, hence is not recommended for sod breaking except in short buffalo grass and in sandy ground. For breaking, a crusher is usually drawn behind disk plows to compact the sod and hasten its decomposition. The natural field for the disk-engine gang is in the South, the Southwest, and the semi-arid plains. Successful farm management in those sections often involves plowing at a season of the year when the ground is too hard and dry for moldboard plows, and the temperature too great for the use of animal power. As before stated, however, where either type may be used, the moldboard is preferable for any power, and for mechanical power the efficiency of the latest flexible moldboard types is so far superior as to make their selection practically universal.

## XVIII

### CONDITIONS AFFECTING THE CHOICE OF PLOWS

**A** HOST of conditions affect the choice of a plow by the farmers of any given section. Topography and the kind and conditions of soil are among the most important. The climate, also, by determining the length of the plowing season, is a large factor, as well as the area of the fields to be plowed within that season. The type of farming which exists determines to some extent the percentage of the total area plowed each year, and the nature of the crops grown affects the depth of plowing. The state of cultivation determines whether or not sod-breaking plows are needed, while individual or local whims may specify a certain type. The amount and price of human labor and the power available for plowing are influential factors, while the financial circumstances of the farmer may prevent his selection of the equipment which would be most profitable.

In the New England and North Atlantic States there are perhaps a greater variety of conditions than anywhere else in the United States, except in California. The country is generally rolling, if not rugged; the soil is varied in its composition and texture, even in the same field, and it is impossible to secure plows which will meet all these conditions with equal success. Stones and sand abound in the soil, which is largely composed of rocks which have been broken down in place, or moved at most only a short distance. There is abundant rainfall to keep the soil moist enough for easy plowing, and as the areas plowed are small, the season usually suffices for the

entire work. Excessive heat is not a drawback at any time.

The farms are seldom large and are cut up into small, irregular fields set off by stone fences which were built at the edges of the early clearings. There is a great deal of small truck farming, considerable dairying, and many farms on which practically all the products are used on the farm itself. In the face of competition with the new and fertile lands of the West the farmers long ago abandoned grain raising as a commercial proposition, and much of the land has been allowed to revert to grazing or meadow land. A small percentage, therefore, of the cultivated land is plowed each year. There is no virgin sod to be broken, and only occasionally is an old meadow brought into rotation.

New England farming suffers from a lack of power, the horse as a rule being small and of racing rather than draft stock. The small native horses of 900 to 1000 pounds and the large Western horses of 1400 to 1500 pounds are not so well adapted to the greater part of New England as medium weight horses of the old Morgan stock. To quote L. G. Dodge, of the U. S. Department of Agriculture: "With the exception of restricted localities, the lack of efficient horsepower is deplorable. Better farming was done, as a rule, twenty-five years ago, when oxen were used, and plows set at the proper depth. The average New England farmer is too conservative and controlled by habit, and he dislikes to adopt new machinery if the increased cost is at all evident. He lays the lack of improvement to topography, size of fields, heaviness of draft of new machinery, etc., when it is in many cases due to his own inertia or lack of foresight. The lack of suitable machinery is one of the greatest hindrances to the New England farmer's producing profitably. In the face of high-priced labor he must learn to use machinery in place of hand labor, and then have suitable horses to draw it, for horses are cheaper than men in terms of product, and,

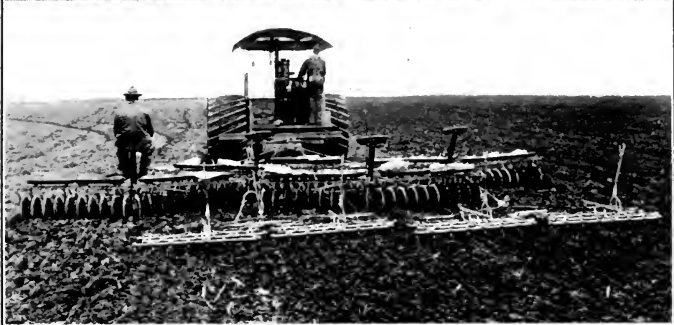
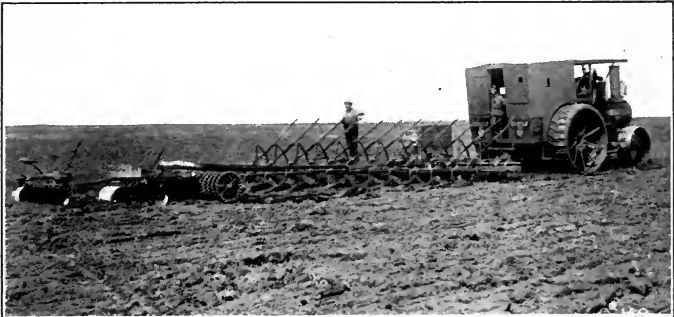

**THE TRACTOR ACCOMPLISHES ALL AT ONCE**

Breaking, crushing and disking with a 120 brake horsepower steam engine  
A tractor with extension rims on the wheels double disking and harrowing  
Caterpillar type of tractor and combined harvester cutting, threshing  
and sacking grain





while horses can be bought, it is often impossible to hire men at any price."

The more vigorous native labor has been drawn from the fields to the factories, and its place taken by immigrants, who are not accustomed to handling large teams or machinery. While the scarcity of labor is deplored on every hand, to a Western farmer the waste involved in the use of one or even two men with a one-horse plow or cultivator is appalling. In most cases the returns from the soil are sufficient to justify the purchase of better equipment, especially when a change in the system of management would provide larger income.

The best New England farmer wants deep plowing and effective pulverization, with the furrows completely inverted; hence the jointer is popular. Under the conditions just enumerated, it is evident that the majority of plows are small and cheap. They are made of cast iron, without riding attachments. Where cast iron will not scour, the chilled steel plow is used because of the extreme wear among the sandy soils and loose rocks. On truck farms of the kitchen garden type the small one-horse plow turning a furrow five or six inches in width is used, this being the one general use of the single moldboard plow. Furrows larger than twelve inches are uncommon. Owing to the steep grades, which make it impossible to turn a furrow up hill, practically all walking plows are of the hillside or swivel type. This plow has a reversible bottom, the point acting alternately as shin and share, and the moldboard being so shaped as to turn the furrow in either direction. In the hands of a man who knows how to run it, the hillside plow will do good work, but even the manufacturers confess their inability to make the plow do as efficient work as the single moldboard.

To some extent, riding plows are taking the place of hillside plows. These are invariably equipped with both right and left hand bottoms, which work alternately, so that the furrows are all turned one way. In certain areas, such as

Aroostook County in Maine, Grand Isle County in Vermont, the Connecticut Valley, and elsewhere, larger fields, gently sloping or level land, and types of farming producing a larger income to the acre, encourage the use of larger horses and implements. The two-way sulky plow, however, is used in preference to the gang plow, as even on level lands farmers prefer to have their furrows turned in the same direction.

Extending along the South Atlantic Gulf coasts and backward for a varying distance from the tidewater lies the section known as the Coastal Plain. This is an area only recently uplifted from the ocean bed, hence is composed of loose sands and gravel in an unconsolidated state. The natural drainage is poor, and artificial drainage has not been effected. Rice, sea island cotton, and the long-leaf pine are the principal crops. Around centres of population, and where transportation facilities are good, trucking is an important industry. The nature of the soil demands a cast or chilled plow adapted to shallow work. The trucking industry demands a one-horse plow, which, however, may be up to twelve inches in width. Riding plows, chiefly of the reversible disk type, are used by the better class of farmers on the larger farms.

Here especially, and elsewhere in the South, the lack of power and efficient labor is creating the demand for engine-gang plows and suitable tractors. The Southern planter is rapidly advancing from the "one-mule" subdivision of his farm to the "thirty-horse tractor" stage. The Negro problem in the South, like the "hobo" problem in the West, strengthens the demand for something that will take production out of the hands of the inefficient mob and concentrate it in those of the intelligent few.

Back of the Coastal Plain, and extending parallel with it, lies the Piedmont Plateau. This is in reality an ancient mountain range worn down to a series of slopes covered with a deep and fertile soil. Conditions encourage the raising of upland cotton, tobacco, and in certain altitudes and climates, wheat,



**THE TRACTOR ACCOMPLISHES ALL AT ONCE**

The individual threshing outfit  
Four horses, one man and a plow  
Two boys, a tractor and four plows



and a diversity of crops. The soils are heavier than on the Coastal Plain, but have been so long under a one-crop system that they have lost to a large extent not only their fertility but their supply of vegetable matter. They are therefore sticky when wet and very hard when dry, with a tendency to run together with a heavy rain, even after plowing.

One of the chief types of farm management in the Piedmont section is that of the plantation, where large farms are parceled out to Negro tenants, who furnish their own equipment. The Negro's acreage is usually small, and in the absence of personal capital he must rely upon advances made by the owner or the storekeeper, who naturally limit him to the bare necessities. The one-crop system is followed, and the ravages of the boll weevil are such that extensive credit based on the returns of the crops is unwise. The Negro's equipment, therefore, is usually limited to a light steer or a decrepit mule, and the cheapest possible implements, including an eight-inch turning plow costing about \$1.50.

The lack of sufficient power has tended to reduce plowing to a matter of small teams and plows, since an average of one work animal per farm laborer is not maintained throughout the Cotton Belt States. The lack of power results in the general use of small moldboard plows adapted to shallow plowing, although the General Educational Board and the United States Department of Agriculture, through the coöperative Demonstration Work founded by the late Dr. S. A. Knapp, are teaching not only diversified farming, but deeper plowing. Three and four mule riding plows, frequently reversible, are thus coming into use. These are usually disk plows, since they are better adapted to working in hard or sandy ground, and in land that has once been cultivated but allowed during a rest period to revert to an overgrowth of timber. Small double moldboard plows, known as "middle-busters," are used in cotton fields to break out the middles — *i. e.*, the old roots from the previous season's planting. Local prejudices and soil

conditions determine the exact style used, just as in the case of the single moldboard plow. Plowing in this section, as in the entire South, may be done at almost any season of the year. The climate, however, is one of abundant rainfall during the winter months and of extreme heat during the late summer and fall. The bulk of the plowing for small grains and cover crops is done between August and November, and for cotton and corn between January and April.

Still further back from the Atlantic Coast, and parallel to the Piedmont Plateau, lies the Appalachian region, which is generally too rugged for agriculture. In the broad valleys, however, farming of the most improved type is practicable where the transportation facilities allow the marketing of products. The hillsides are farmed only by a low class of poor whites, and the plows and customs of this class are little advanced over those in general use a century ago.

In some sections of the South, particularly in the Delta regions of the Mississippi and the so-called black waxy land of Louisiana and Texas, a sticky, rubbery soil makes necessary the exercise of the greatest ingenuity in providing plows which will turn the surface. One type of plow has a short steep moldboard, four mules being required to a single plow. No attempt is made to make these plows scour, the pitch of the moldboard being sufficient to turn the earth across the surface with the expenditure of a great amount of power. On the other hand, a long curving moldboard, not unlike the prairie breaker, is successfully used when the soil is in a favorable condition of dryness. In developing the moldboard for this particular soil type every device which the imagination could suggest was tried out. A moldboard made of glass failed, as did one composed of rollers. Persistent attempts were made to dry the earth as it passed over the moldboard with a small furnace underneath the latter, or even to oil the moldboard, oil being forced through perforations. The nearest approach to success under all conditions was a wooden moldboard covered with

pigskin. A local farmer with this combination succeeded in plowing while the various factory experts were experimenting in vain.

In the North Central States, east of the Mississippi River, and in Iowa and Missouri, the ground is fairly level or gently rolling, with good natural drainage. The soils are glacial loams containing sand, gravel, and loose boulders, some alluvial soils; some loess, usually known as clay or silt loam, and some tough sticky "gumbo." The rainfall is moderate, and the heat not excessive, during the plowing season. The fields and farms are of moderate size, and in the older states the fields are apt to be small and irregular. General farming is the rule, with from one third to one half of the cultivated area plowed each season. Corn and other intertilled crops require deep plowing — *i. e.*, five to eight inches, and the small grains something less. Following intertilled crops, the small grains, especially oats, are often disked in without plowing. Very little virgin sod remains to be broken, and the tame sod is usually broken by general purpose models. The soils require a moldboard which will take a high land polish, hence the soft-center steel plow is generally used, with the chilled plow next in point of popularity.

A large number of horses in proportion to laborers is provided, and owing to the fact that horse raising is a prominent industry, the excess of power required at plow time can be provided for on a great many farms. The work horses are of large size, probably averaging 1300 pounds in weight. Labor is scarce and high priced, but as a rule quite efficient in handling teams and large implements. Sulky and gang plows are naturally adapted to conditions, and the farmers are in position to purchase the equipment which best serves their purpose.

Engine gang plows of from four to six bottoms are coming rapidly into favor with the introduction of small tractors of such horsepower, weight, and flexibility as to speed, as adapt them to corn belt conditions.

In old ground plowing, most farmers desire to have the furrows well pulverized, hence the prevailing types of moldboard are the stubble and general purpose. For very heavy soils, even in stubble plowing, a long moldboard with less pulverizing effect is used on account of the draft. There are many walking plows, even where riding plows are found on the same farm. The majority of plows are right hand, although in parts of Indiana and Ohio the left-hand moldboard is insisted upon. There is no difference in the quality of the work nor in the ease of manipulation. A possible explanation of this preference is that the jerkline largely used in the South comes handiest on the left or "haw" side. The team is guided by jerks on a single line, and the guide horse necessarily walks in the furrow. A few disk plows and a few plows made especially for ox power are sold in this section.

In the other North Central States west of the Mississippi River the topography is even less rolling. The soils are glacial, with wind-deposited or alluvial loess over most of the area. In many sections there are large deposits of "gumbo" soil of alluvial origin. Soft-center steel is universal as a moldboard material. Frequently, however, wrought-iron rods take the place of the moldboard in sod or very tenacious soil. The climate allows work in the fields during a large part of the year, although, owing to the fact that spring grains must be put in early, a considerable amount of the plowing must be done late in the fall. The farms are large, with large fields and few fences. Practically one half of the total cultivated area is plowed each year on all farms and on many the entire acreage is plowed, wild hay for horse feed being cut from the open prairie. Thousands of acres of wild land remain to be broken, and the prairie breaker is as common as the stubble plow. The Northwest Provinces of Canada present practically the same conditions, though large areas of brush land call for a heavy type of plow known as the brush breaker.

Horse raising is not so successful as in the older sections,



owing to the lack of employment during the dry season and the long winters which require food and shelter for the horses. The horses, however, are usually of fair size, though many small horses bred upon the range are in common use. As a rule farmers are prosperous and able to select the most approved type of implements. Labor is scarce, high priced, and often unreliable, and every effort is made to utilize animal or mechanical power in place of human efforts.

The walking plow is not a practical implement for regular use on the average farm in the Northwest, owing to its waste of human labor. The large area cultivated makes the two-furrow gang plows the most generally popular and useful for use with horses. The large area of level land, free from obstructions, has created a remarkable field for the engine gang plow, and the percentage of plowing done by mechanical power is rapidly increasing each year. In this section the moldboard plow is by far the most popular. The disk plow is used only occasionally, and then almost always in land which has first been subdued by the use of the moldboard. Where the soil has much clay or gypsum and lime, the steel moldboard scours better than the chilled. Cast shares can be used with either moldboard in all but a few soils, and are cheaper than the steel "lays." The use of larger animals has been accompanied by a gradual increase in the average size of plows, even in the last decade.

On irrigated farms in the West the two-way sulky plow is growing in favor, owing to the fact that no dead furrows are left to interfere with the distribution of water. This is a curious and unpremeditated adaptation of a plow designed especially for hilly ground in New England.

Disk plows are used to subdue much of the sage brush prairie found in the West and Southwest, and the disk plow increases in favor toward the southern latitudes. The topography and size of grain farms in Colorado, Oklahoma, Texas, and New Mexico favor the use of mechanical power and engine gang

plows. Probably four fifths of the traction outfits include the disk engine gang.

Conditions in the Far Western states require a greater variety of farm equipment than in any other section, and practically every type of plow found elsewhere in the United States is used. The land varies from level to mountainous, the farms from tiny patches of highly valuable fruit and truck crops to immense grain ranches. All climates and all altitudes are to be found. The great diversity of crops, the variation in kind and depth of soil, make the depths of plowing widely different in different sections. Not only are the conditions varied in the extreme, but much more severe than those prevailing east of the Rocky Mountains, and the demand for any particular type of plow is limited. Neither machinery nor agriculture is standardized. It is therefore difficult to interest Eastern manufacturers in providing plows fully adapted to local needs. The same conditions discourage the establishment of factories on the Coast, though many circumstances are favorable. Buildings are cheaper than in the East and labor often as cheap. Crude oil furnishes cheap fuel, and freight rates on raw material from Eastern mines are less than on finished products. Only local manufacture or closer study by Eastern makers will result in plows satisfactory for every condition.

Plows must be made heavier, stronger, of better materials and simpler, especially for California. The soils are heavier and many contain cementing materials which bind them in masses like concrete. There is no frost and little rain at the proper time, hence these soils must be loosened by machinery. Along the Coast the salt air soon eats up iron and steel and lever handles of steel last only five to nine months before breaking. Plow bottoms frequently outlast the frames. Wood is demanded in the frames and wherever else possible. Back from the Coast the hot sun takes the sap out of unseasoned wood, and all stock must be dried for several years before using. White teamsters are seldom available in California, the work

on large ranches being done by Japanese, Mexicans, and Indians, none skilled in handling teams and adjusting plows. Eastern improvements are therefore apt to be detrimental. The ideal plow, then, is one made to go through any soil, plow deeply, and run with little attention from the driver. On the other hand, the cost of such a plow is of no object to the large rancher and he ordinarily rebuilds purchased equipment to suit his own ideas. Plows suited to local conditions sell readily at from 25 to 100 per cent. higher cost than corresponding types in the Central States.

The sand and gravel in the soil call for chilled, rather than soft center, steel in plow bottoms, and in dry land the disk plow is popular. It allows plowing to be done before the fall rains, after the start of which it is often impossible to plow the desired acreage. The pumice in volcanic ash soils in the Northwest necessitates the use of a chilled plow. The soil is more easily pulverized, hence a lower, straighter and less sharply curved moldboard is used than in the heavy soils of California. Prairie breakers are not extensively used. The shallowness of the layer of fertile soil in many places limits plowing to a depth of from four to six inches and favors the use of shallow-turning plows such as the Stockton gang. Work in vineyards requires a small plow, closely coupled, with an adjustment allowing the handles and beam to be set to one side and the plow to run close to the vines. For both orchards and vineyards the small one-horse plow is common and many so-called "pony" gangs, each turning several narrow, shallow furrows, are used. The reclaimed marsh, or tule, lands require plows of great clearance. Engine gang plows are numerous on the great ranches, but steep grades prohibit the economical use of tractors over a large part of the grain-raising country. There are few medium sized holdings, the majority being either small patches of five to twenty acres, or ranches of from 400 acres upward. In consequence few sulky plows are used as compared with one-horse and gang plows.

Plows for unusually deep tillage have never become generally popular, in any section, because of the power required to operate them. National and state agricultural authorities recommend their use at least once in two or three seasons, but only an occasional small farmer owns one. For the cultivation of sugar beets in Kansas, Colorado, California and other states in the West, and of sugar cane in the South, in Porto Rico, Cuba, and the Hawaiian Islands, plowing at least twelve inches deep is regarded as a necessity. In the culture of cane, in the South, a large, heavy plow with double moldboard is used widely for breaking out the old middles and for bedding up the rows. The cable-drawn plows used on sugar-beet ranches in the West have much higher moldboards in proportion to width of furrow than ordinary old land plows, and have much greater flare, or overhead. This is due largely to the higher speed at which they are drawn. Numerous gangs have been put forth, in both disk and moldboard types, in which one plow is set below and to one side of the other. As a rule these are made to bring up the lower stratum and deposit it upon what has been the surface layer. While this is objectionable in case too much fresh earth is brought to the surface at one time, these plows eventually secure a thorough mixture of the soil and form an ideal seed bed up to 18 inches in depth. Up to the present time makers of these plows have failed to make them in gangs suitable for mechanical traction power.

For loosening the subsoil without turning it to the surface, the subsoil plow is used. This consists of a shoe or beak, attached to the bottom of a powerful knife-like standard. Usually it is run in the furrow following an ordinary turning plow. It is used chiefly to prepare the subsoil for deeper root growth and to increase the moisture reservoir. In regions of moderate rainfall it is seldom used, and deeper plowing in dry-farming sections is rendering the subsoil plow less popular.

## XIX

### MECHANICAL PRINCIPLES OF THE PLOW

**T**ILLAGE is Manure," says Jethro Tull. Kropotkin, the famous Russian author—exile, found that minute pulverization paid so well in crop returns that he could afford to lift and carry the earth from his garden to a grinding machine and back again. The late Dr. Seaman A. Knapp, in reviewing the gains secured by applying modern methods and machinery to the primitive agriculture of the South, stated that the best seedbed added 100 per cent., the best cultivation 50 per cent., and the best seed only 50 per cent. to the crop as compared with average practice. The profit was increased tenfold where the yield became threefold. Tillage all but takes the place of moisture in dry farming, and is undoubtedly the cornerstone of good farming everywhere.

Pulverization, that is, the securing of proper physical condition of the soil by stirring or otherwise, is claimed by most writers to be the primary object of tillage. Checking the growth of, and burying, undesirable vegetation is secondary, though a new school of scientists is endeavoring to show that preventing weed growth is even more important than securing proper physical condition. Plowing is the fundamental operation of our present tillage system, and the plow the most effective tillage implement.

Pulverization changes the hard soil into a deep mellow seedbed, offering little resistance to the travel of plant roots in search of food and water. It enlarges the feeding area of roots, by placing more plant food and moisture within easy

reaching distance. It checks the cooling of the soil by surface evaporation, and thus favors the germination of seeds. It retards the loss of moisture in the heat of summer. It promotes bacterial action in the soil, the fixation of atmospheric nitrogen by bacteria, and the change of plant food from the insoluble to the available form. It enables the soil to recover in the shape of dew a part of the moisture lost by evaporation. By more than a thousandfold increase in the area of the soil grains or kernels and the volume of the air spaces between, it enables the soil to fix a larger amount of nitrogen from the air without bacterial aid.

Plowing with properly designed moldboards accomplishes by far the greatest amount of pulverization. In addition, it checks the growth of weeds which steal food and moisture, burying them beneath the surface, where they decompose to improve the physical condition of the soil, and to yield up supplies of humus and plant food for the benefit of plants of economic importance. An analysis of the action of the moldboard upon the furrow shows how the primary objects of plowing are accomplished. Professor King has likened the action of the share and the moldboard to what takes place when all the pages of a book are grasped between the thumb and fingers and bent abruptly. The furrow slice is divided into thin layers which slide over each other like the leaves of the book, dividing the soil into horizontal flakes. It will be remembered that it was the old Berkshire plow's separation of the furrow into layers that aroused and held Jethro Tull's admiration.

The inner wall of the furrow slice, next the land, must travel faster than the outer edge as it comes up and over. In the low moldboard of the prairie breaker this additional travel is not great enough, nor the turns abrupt enough, to break the tension of the elastic sod, which is usually cut in very shallow strips. With a deep furrow, the horizontal shearing of the soil layers over each other takes place, even though the elas-

ticity of the sod may not be overcome in shallow plowing. In stubble plows, the moldboard is made steeper, and the inner edge of the furrow slice must travel a much greater distance. The inner edge being required to turn a sharp angle while the outer edge remains stationary, the slice is broken by perpendicular fissures which cross it at right angles to the landside.

A third line of cleavage is secured by the effect of the curvature of the moldboard. Since the soil layers do not slide over each other with the freedom of the leaves of a book, the surface layer, which is also more tenacious, often curves sharply without crumbling. The layers nearer the moldboard must therefore be extended sufficiently to form concentric arcs of longer radius. The steeper and sharper the moldboard, the more will the natural elasticity of the soil be overcome, and deep fissures will extend parallel to the landside and perpendicular to the bottom of the furrow. In practice, any one, or all, of these three effects of the moldboards may be lost through carelessness or avoided by design.

The plow may be likened also to a plane. If the bit of the plane is sharp and properly set, it cuts easily. If a thin shaving is cut, the lifting action of the bit placed at a low angle is not sufficient to overcome the elasticity of the wood, and the shaving comes forth in a smooth, continuous band. If the bit be set at a greater angle, even the thin shaving is sharply broken at frequent intervals, and it requires greater force to drive the plane. If a deep shaving is taken, then the bit must be set at a practically impossible angle if the shaving is not to be broken. Ordinarily, the difference in the distance traveled by the upper and lower surfaces of the shaving, about the angle formed by the board and the bit, is sufficient to overcome the natural yielding of the wood, and since the fibers are not free to glide over each other, the lowest layer, which travels farthest must be broken at frequent intervals. This accounts for the great amount of power required to move a plane under improper conditions of adjustment.

Soils as well as woods, vary greatly in their tenacity. In a light, sandy soil less abrupt curvature of the moldboard will be required to fracture the furrow slice than in a stiff clay. The friction of the furrow slice against curves in the plow consumes more and more power as the curves are made more abrupt. In the same soil the breaker moldboard runs with about 20 per cent. less draft than the stubble moldboard, hence the power required to pulverize the soils adds at least one fourth to the power required to cut and turn the furrow, and to overcome the friction of the soil upon the plow. While the stubble moldboard requires additional power on account of pulverizing, the tenacity of the prairie sod is so great that, even at a much shallower depth of plowing, with practically no pulverization, the average sod-breaker takes from 40 to 60 per cent. more power than a stubble plow of the same size working deeper in old ground.



## XX

### WHEN TO PLOW, AND HOW DEEP

**P**LOWING cannot always be done under the best conditions. It must ordinarily extend over a considerable period, during which conditions may pass from one extreme to the other. It goes without saying that the farmer should endeavor to do the bulk of his work at a time when the desired objects can be most effectively accomplished. Climate, latitude, altitude and crops all influence the time of plowing. To assist the new farmer in planning his season's work, the United States Department of Agriculture has collected from all portions of the country the usual dates of various crop operations. If one does not have this information, it is safe to follow the practice of the best farmers in the neighborhood, but better still is a knowledge of the effects of plowing, so that if for any reason the farmer wishes to plow out of season, he can judge for himself the fitness of the soil.

Most farmers know that soils are composed of particles of rock of varying size and composition, with a certain amount of organic matter derived from the decay of animal and vegetable tissues. Varying amounts of water are held upon the surfaces of the soil kernels in films of greater or less thickness, though occasionally the spaces between the soil grains may be entirely filled. There is a certain amount of mineral matter normally in solution, but often deposited upon the soil particles by the evaporation of water. King adds that in most soils, particularly the clayey types, there occurs some aluminium silicate, combined with water, which gives these soils their

sticky, plastic quality when wet. The soil particles may occur in a finely divided state, as in silt or clay soils, or in the coarse state found in sandy or gravelly soils. Usually, and especially in case of cultivated soils composed of finer particles, the soil grains occur in clusters, or kernels. The varying sizes of these kernels largely determine the physical characteristics, or texture, of the soil. The larger the grains and kernels, the more open and permeable the soil to the action of water and air through the air spaces within it, and the lower the moisture-holding capacity becomes, owing to the reduction of the total surface. The optimum condition for plowing depends largely on local conditions, including the nature of the soil.

Where the soil particles are extremely minute, the soil may contain a large percentage of water, yet yield a limited amount for the use of plants, owing to the tenacity with which the moisture clings to the soil grains. It is practically impossible, except under extreme heat, to dry a soil entirely. In fine-grained soils it is desirable that the soil kernels be of fair size, both to increase the ease with which plants can secure water and to render the soil more porous. If plowing is done while the soil is too wet, these kernels are easily broken down, and the soil grains will assume the closest possible arrangement, making the movement of air, water and plant roots extremely slow and difficult. A high content of lime in such a soil tends to flocculate it — *i. e.*, collect it into kernels — hence soils naturally or artificially limed may be handled safely when containing a fair amount of moisture. If such a soil is plowed when too dry, the plow will shear it into thicker layers, and coarser kernels will be formed. If very dry, the soil has practically no elasticity, and is merely broken into clods. In sandy soils the tendency of soil grains to form clusters is very slight, hence under any conditions there is little shearing action. Sandy soils may be plowed at any convenient time, provided, as sometimes occurs in the South, heavy rains do not follow shortly afterward to cause the soil to run together and destroy

the effect of plowing. It is the shearing action of the moldboard upon the soil kernels, causing them to divide at the edges of the layers, that makes plowing in tenacious clay or gumbo soils so much harder than in sandy or loamy soils.

Plowing should be done when most effective. It should be done with reference to the objects desired most, weeds or other vegetation being buried at a time when their growth will be most injured, if that is the principal object; or when the desired texture of the soil may be reestablished, if that is the prime consideration. Extremely dry soils may profitably be broken into lumps of considerable size, for in most sections frost or rain can be depended upon to reduce their size later. This practice is especially good if high winds might cause drifting of too finely divided soil. Fall plowing may well be left rough, in order that snow may be caught to melt into the ground, and frequently a fringe of vegetation left uncovered will assist in catching drifting soil and snow.

#### DEPTH OF PLOWING

The depth of plowing depends largely upon the character of the soil, the climate and the crops to be grown. Channels between the soil kernels are easily formed in sandy soils without plowing; consequently the principal object is often to bury vegetation. Plowing too deeply may render the soil too porous and hasten the oxidation, or burning out, of organic matter. It is seldom desirable to plow very sandy soils to a depth of more than three or four inches. Very retentive soils devoid of humus, and those containing cementing elements, should be broken to a much greater depth at least every other season. Done at the proper time, and by the proper plow, this soil will be granulated and loosened, thus securing the porous condition favoring plant development. Between these two extremes lies a great range of soil types requiring greater or less depth of plowing. Sod, either wild or tame, is usually broken shallower

than old ground, so that tearing and pulverizing implements may have a thinner layer to work upon. It is quite necessary that a shallow layer be well cut up, as a mat of dry vegetation between the subsoil and seedbed checks the capillary rise of water. Occasionally the depth of fertile soil limits that of plowing. Beavers says, in *Farmers' Bulletin 398*: "It has been demonstrated by farm practice in the South that where the soil is plowed deep more fertilizer can be used profitably than on soil plowed shallow."

The cereal crops are naturally rather shallow feeders; hence in humid climates plowing is at less depth for wheat, oats, etc., than for corn and root crops. They require a firmer seedbed, which is of further advantage in saving power at cutting time. Corn requires a larger feeding area for its roots than the smaller cereal plants; hence plowing in corn ground is usually from one to three inches deeper. The leading agronomists of the Corn Belt unanimously recommend plowing for corn at a depth of from six to nine inches. Recent experiments with a deep tilling machine have been followed by a remarkable increase in the yield of corn on fields plowed to a depth of from ten to fourteen inches. Root crops, such as potatoes and sugar beets, require deep plowing, twelve inches for the latter being considered the possible minimum in the heavy adobe soil of Colorado and California.

In the semi-arid regions deep plowing is prerequisite to highly successful farming. However, Western farm horses are often small, few in numbers, and not cared for in a way to obtain their maximum efficiency; hence, shallow plowing is the rule rather than the exception. The soils have become solidified by the tramping of many generations of animals and by the rains of centuries. Moisture penetrates only a short distance except where the ground has been loosened by artificial agencies. Professor Buffum, of Wyoming, states that some of these soils, when in excellent tilth, will absorb over 40 per cent. of their weight of water. As the lack of moisture is the limiting

factor in dry-land crop production, the shortage of power necessary for deep and thorough cultivation at all times is a serious obstacle to profitable farming.

Deep furrows, as before pointed out, are more apt to be pulverized than shallow; hence to some extent the plow performs for the subsoil what pulverizing implements do for the surface layers. Three or four inches of the surface soil must be kept stirred as a dust mulch to check the capillary rise of water and consequent loss by evaporation. Underneath this mulch a dry crust inevitably forms during the growing season; hence the actual feeding area of the roots does not begin until a depth of five or six inches is reached. As between plowing eight inches and ten inches deep there is, therefore, a difference of at least 100 per cent. in the zone available for the maintenance of the plant.

The moisture reservoir is increased in the same ratio. The deeper the moisture is stored, the greater is the assurance of an abundance for the needs of the crop, as each successive inch dries out more slowly. Professor Buffum says: "A soil weighing one ton per cubic yard weighs approximately 1613 tons per acre, taken one foot deep. If such a soil will absorb and hold 20 per cent. of moisture and is plowed six inches deep, it will take up 161.3 tons of moisture per acre. A rainfall of 1.4 inches will supply this amount of moisture and fill up our six-inch reservoir; if the ground is plowed only three inches deep and the subsoil is hard, it would not be able to store a rainfall of more than seven tenths of an inch, and should more water fall at one time, it will be lost and may wash the soil away with it. If plowed nine inches deep and put in good condition, such a soil reservoir would absorb and hold over two inches of rainfall at one time. A soil already containing considerable water would be filled up with less rain, and deep plowing would be still more important. . . . Where the soils are light and winds drift them, shallow plowing may result in all the top soil, down to the sole of the furrow, being blown away.

Deep plowing, on the contrary, throws up heavier and rougher furrows, and tends to anchor the soil in place. Plowing deep, therefore, prevents both washing and drifting."

In many dry-farming sections the rainfall is so light that summer fallowing must be resorted to. This consists of cultivating an empty field during one entire season to prevent plant growth and conserve the rains of that year for the use of the next year's crops. It is seldom necessary to provide as great storage capacity as is given by the expensive method of subsoiling, but plowing ten or twelve inches deep with ordinary plows places the moisture reservoir at a safe depth and makes summer fallowing a less expensive means of insuring a crop.

Deep plowing cannot be accomplished all at once on any new soil. Where the soil is heavy and compact, the prairie is apt to be covered with "short-grass" sod, indicating that only an inch or two of the surface is in condition to sustain plant growth. The soil underneath is apt to be cold and unproductive, hence must be mixed slowly with the upper layers and put into proper physical condition by good tillage and exposure to the sun and air. Fall plowing can be done more deeply on this account than spring plowing, owing to the weathering action of frost and snow. For a year or two after the ground is first broken the plowing should not be at the same depth as the first breaking, as this will expose undecomposed vegetation, the lack of moisture in dry climates retarding decay. The ultimate depth desired should be attained gradually, and afterward the depth should be varied from year to year to avoid forming the "share hardpan." This is a hard, glazed condition of the sole of the furrow which renders it impervious to water. The trowel-like effect of the share and the tramping of the furrow horse's feet bring it about.

A firm seedbed is especially important in dry-land agriculture to insure prompt germination. In deeply plowed land it is therefore advisable to use a subsurface packer. This repacks the intermediate layers, but leaves the top and lower soil

loose. Disking the ground before plowing, or, better still, immediately after harvest, retains much moisture that would otherwise be lost. It keeps the ground in condition for easier plowing, and establishes a better capillary connection between the furrow slice and the subsoil than when hard clods, or masses of vegetation with dead air spaces between, are turned to the bottom.

## XXI

### DRAFT OF PLOWS

**T**HE first steps in the development of the plow were those tending to make it an effective instrument. The next were naturally those looking toward the elimination of human labor, and finally the draft of plows was studied, not so much, perhaps, from humanitarian motives as from a sense of financial loss through wasted power. Comparable draft tests are so hard to obtain, according to plow experts, that no data should be accepted unless all conditions are known, repeated tests are made, and differences in draft so great as to preclude any possibility of experimental error. Nevertheless, the question of draft of implements is so little regarded by the average farmer that approximate truths are worth noting.

The total draft of a plow is the product of numerous factors, each of which will vary under different circumstances. Among these may be considered the weight of the plow, its shape, the various adjustments, the condition of the plow with respect to sharpness and scouring properties, the angle of draft, the character of the soil, the skill of the plowman, the presence and adjustment of various attachments, the speed of travel, the size of the furrow, and others of less importance. The sum of these variations may easily amount to 50 per cent., and often to 100 per cent. When it is considered that an unavoidable loss in power of 10 per cent. is probably a low estimate under present conditions, the tax on inefficiency is seen to be enormous. The annual plowing bill of the United States may be estimated at approximately four hundred and fifty millions



of dollars. Experiments go to show that very common causes effect increases of from 5 to 40 per cent. each in the draft. If the United States Department of Agriculture, through a Bureau of Agricultural Engineering, were to ascertain and induce general recognition of the principles of draft, the farmers of the country could well afford to support several Departments of Agriculture, each with its corps of 11,000 trained workers.

The draft data given in the following paragraphs are derived from numerous sources, the chief of which are the plow trials conducted by the New York Agricultural Society at Utica in 1867, and reported by Gould; tests in Missouri and Utah two decades ago by Sanborn; and in Illinois by Ocock in 1904. The earliest of these trials were the most comprehensive, but since then great improvement has been made in both plows and dynamometers, and tests of modern plows might not bear out the conclusions drawn at that time. It is extremely unfortunate that the draft tests have received so little attention from agricultural engineers, and that no comprehensive data are available as to variations in the draft of all modern implements.

The plow runs lightest when so adjusted as to allow the sole of the landside to run level from point to heel; to cause the line of draft to pass at the same time straight from the centre of resistance through the attachment at the end of the beam to the point where the power is applied, and to render the angle of draft — *i.e.*, the angle of the line of draft with the base line — as small as the application of power will allow. The location of the centre of resistance varies with the character of the soil, the shape of the plow, and the size of the furrow. If power could be applied at the centre in a horizontal line, the plow would move with the least possible draft and with perfect balance. Obviously, however, it must be applied at a higher point, varying with the power used, and this lifting force must be overcome either by adjustment of the plow or by pressure on the plow handles. In the same way, if power is applied to the

right or left of the centre, an opposed force must be exerted to make the plow run evenly.

The true line of draft is always from this centre to the point where power is applied; hence any enforced angle, such as caused by sagging of the traces, holding up the traces by straps, extending or shortening the beam, and raising or lowering the draft pin in the clevis, disturbs the adjustment. The determination of the centre of resistance is, therefore, important.

Since the greatest effort is expended by the shin and share in severing the furrow slice from the land, the centre must lie much nearer the landside than the furrow side of the plow. Again, since the resistance of the cutting edge of the share and the sole are greater than that of the moldboard, the centre must lie nearer the sole than to the crest of the moldboard. A third plane of resistance stand perpendicular, at right angles to the landside. Cross sections of the plow in planes at different distances from the point show triangular areas increasing more rapidly in size than the cutting edges do in length. The force required to drive the plow into the ground does not increase in proportion to the area cut, and the centre of resistance will lie in a smaller cross section than that of the whole furrow. In other words, it will lie much nearer the point than the heel of the share, being farther forward in stiff soils, in shallow plowing, and on a rather blunt plow point, than under reverse conditions. The centre lies at the intersection of the three planes, and its approximate location must be known in order to adjust the point of hitch so that it will fall naturally within the line of draft. On stubble and general purpose plows it will lie close to the shin and to the junction of share and moldboard. On plows designed for breaking tough sod at a shallow depth it will lie closer to the point and the sole. Professor Gilmore, of Cornell University, states that it is located behind the moldboard and two and one half to three inches from the wall and sole of the furrow. No other condition within the

control of the operator so vitally affects the resistance of the plow as the one just reviewed, and success demands careful observance of the principles governing the lines of draft and resistance.

According to Sanborn, the plow shows the lightest draft when set to cut the widest furrow of which it is normally capable. This is probably accounted for by the remarkable results of an experiment at the Utica trials which showed that 55 per cent. of the draft of the plow was caused by the cutting of the furrow slice, 35 per cent. by the friction of the sole, and only 10 per cent. by the work of lifting and turning the furrow. The average draft of a number of plows running in the empty furrow was 168 lbs. The whole draft was 476 lbs., and that with the moldboard removed 434 lbs. The difference between 168 lbs. and 434 lbs. was taken to be the draft required for cutting the furrow slice. Sanborn states later that 42 per cent. of the draft is used by the share and landside, and another writer puts the moldboard friction at only 2 per cent. These figures will not hold for all conditions, but even an approximate idea of the division of draft explains many frequently observed facts.

In relation to the size of furrow, the cutting edge should be as small as possible. A furrow 4 x 12 inches has a line 16 inches long which must be cut, and an area of cross section of 48 square inches, a proportion of 1 to 3. One 6 x 14 inches has a cut surface of 20 inches and an area of 84 square inches, a ratio of 1 to 4.2. The larger the furrow cut, therefore, the less the influence of the cutting edges on each square inch of cross section, which is the commonly accepted unit of comparison. Sanborn found a constant decrease in draft per square inch as the furrow was deepened or widened up to the normal capacity of the plow. When made to cut wider, narrower, shallower, or deeper than the adjustments of the plow ordinarily permitted there was an increase in draft of 15 to 20 per cent., much harder work for the plowman and a poorer quality of plowing.

The point of hitch is lower on a plow than on a wagon. Frequently a strap is provided at the saddle or rump to hold up the traces while the team stands. When the same team and harness are used on the plow an angle is formed at the trace. Sanborn found the downward pull at this point to equal 50 lbs., or one third the pulling power of an average 1200 to 1500 lb. horse. The angle was not as great as he had frequently observed, but even then a third of the animal's power was being used to gall and annoy it instead of being applied to the work in hand.

The New York Agricultural Society's estimate of the division of the draft explains the enormous difference in draft between a sharp share and a dull one, also why it is possible to add the weight of a heavy plow frame and a driver to the load of the horses, yet not increase the draft. The friction of the sole, estimated at 35 per cent., is transferred almost entirely to wheels in the sulky plow. The landside is made much shorter, and the heel of the latter is usually carried a fraction of an inch from both the bottom and side of the furrow by means of a staggered wheel. The lifting of the soil is borne by the larger wheels and frame, while the relatively small moldboard friction remains constant. Sanborn shows only .19 lb. per inch, or 3.3 per cent. difference in draft in favor of walking over sulky plows, averaging three tests of each, but observes that the draft of sulky plows increased on the hills. Considering amount and quality of work, the difference in draft is negligible. In fact, an unskilled plowman will even cause greater draft in a walking plow by constantly disturbing its adjustment. The influence of the operator's efforts to help the adjustment was seen in one trial in which different plowmen in successive furrows varied the draft from 5.19 to 4.45 and 5.61 lbs. per inch, respectively, while another on several trials ranged from 5.25 lbs. to 6.15 lbs. A small truck or gauge wheel under the beam of the plow should, theoretically, increase the draft by adding friction and by frequently disturb-

ing the line of draft as it encounters obstructions. Practically it is shown to save from 9 to 14 per cent. by the steadier running of the plow when it, and not the handles, is used to regulate the depth.

The power absorbed in severing the furrow slice demands that shares be not only sharp but properly sharpened. Sanborn reports a difference of only 6.7 per cent. in favor of an old point resharpened over a dull point on the same plow, but an advantage of 36 per cent. in favor of a new point over the old one resharpened. A straight edge drawn across the share at a right angle to the landside should touch for an inch or so on the under side of the cutting edge. The average blacksmith will hardly restore to a share the nice adjustment given it at the factory, and it is an open question whether a farmer can long afford to waste power on resharpened shares. Sanborn states that in the case quoted the defects were not easily discernible and the work compared favorably with that of the average smith.

At all events, the farmer should not waste power on dull shares.

At the Winnipeg motor competition in 1909 two six-bottom engine gangs of the same make, supposed to be cutting the same depth and width, showed a difference in draft of 45 per cent. Most of this can be attributed to the fact that one was a new plow, just from the factory, especially ground for the occasion, while the other had been used for several months for plowing in stony ground, with only ordinary attention.

Speed of travel as a factor of draft is an unsettled question. Theoretically, the resistance should increase in a definite ratio with the velocity, as in case of bodies moving through air and water. Practically, within the ordinary limits of speed, the higher rate is considered by some to decrease draft by inducing better scouring and turning of the soil by the moldboard, especially in heavy soils. Gould's experiments at Utica resulted in the conclusion, that in plowing friction is entirely indepen-

dent of velocity, with this exception, that greatly increased velocity slightly increases the force required to lift and turn the furrow slice, owing to the distance the dirt is thrown.

The rolling coulter is said by Prof. F. H. King to reduce the draft in sod ground from 20.86 to 25.34 per cent. Gould declared in favor of the coulter because of its saving in draft, but Sanborn claimed a loss of 10 to 15 per cent. due to the tendency of the coulter attached to the beam to raise the plow out of the ground. Practically, the coulter is regarded as essential for the majority of conditions, and in the absence of recent tests it may be assumed that the thin edge of the coulter saves power in cutting the furrow wall as compared with the rather blunt shin of the plow bottom.

From the variation in the shape of plows designed for different conditions we are led to expect great difference in draft in the same soil. In the English experiments already quoted there was a difference of 46 per cent. between the plows having the lightest and the heaviest draft under the same conditions; 53 per cent. was the maximum difference in tests in 1850 by the New York Agricultural Society. Sanborn found variations in sulky plows ranging from 5.9 to 7.5 lbs. per square inch of cross section, and in another experiment from 5.15 to 6.28 lbs. in walking plows, all furrows being of the same size. King reports a comparison of the draft of sod and stubble plows in clover sod, two years old, as wet as could be worked. The furrows were approximately 5.5 x 14.4 inches. The sod plow had a draft of 4.45 lbs. per inch and the stubble plow 5.38 lbs. The difference, .93 lb., is mainly due to the work of pulverization, which is added by the stubble plow to that of cutting, lifting, and turning. At the Winnipeg motor contest in July, 1909, one make of engine gang plows averaged about 2.5 lbs. per inch lighter in draft than the other, all conditions being equal. Not only the shape but the weight and adjustment of different plows must be taken into consideration, however.

The angle of the share with the landside is an important factor, and must be adapted to different soils. For instance, in Colorado, in dry alfalfa fields, a plow with an acute angle will dodge the roots, while one having a share at nearly a right angle to the landside will chip up the baked ground and break or cut the roots cleanly. In mellow loam the slanting cut must be used. In this case the soil is not firm enough to hold the roots taut, hence they double over and clog a share which is set at a wide angle.

Soils differ greatly in their cohesive properties. The average draft of nine plows in an old English test, for a furrow 5 x 9 inches in each of five different soils, was as follows: Loamy sand, 227 lbs.; sandy loam, 250 lbs.; moory soil, 280 lbs.; strong loam, 440 lbs.; blue clay, 661 lbs.; a difference between extremes of 194 per cent. An average of fifty-seven of Professor Sanborn's tests on varying soils in Missouri in 1888 gave a draft of 5.26 lbs. per square inch in area of the cross section of the furrow slice turned. In Utah, several years later, the same number of similar tests averaged 5.94 lbs. per inch. Four hundred and fifty tests in an Illinois cornfield averaged 4.76 lbs. In Missouri 500 lbs. turned a 7 x 16 inch furrow on timothy. Over 600 lbs. was needed for the same furrow in red clover in Utah, and still more for alfalfa. Seven trials on clover gave an average of 6.47 lbs. per inch, and six on oat stubble gave 4.68 lbs. At the Winnipeg motor contests of 1909 and 1910 the average draft per 14-inch bottom, going three one half to four inches deep in virgin gumbo sod, was 770 lbs. and 795 lbs., respectively, or 13.75 to 16.3 lbs. per inch. These and other figures might be cited to illustrate the difference in draft due to soil conditions, but even relative figures are very few.

It may be said that for ordinary depths and widths of plowing the draft per square inch of cross-section ranges from about three pounds in sandy soil to seven or eight in clay, six or seven in tame clover sod, and ten to fifteen pounds in virgin

prairie sod. The draft of a 6 x 14 inch furrow would present an extreme range of from 250 to 900 lbs., with 400 to 500 lbs. as an average for old land in the Middle West.

The amount of moisture in the soil affects the draft, as the soil kernels are more easily sheared when wet. In two sets of tests on clover sod, dry soil caused from 142 to 144 per cent. increase in draft over moist soil. In corn stubble in Illinois, the same soil when so dry as to be loosened in chunks averaged 4.93 lbs. per square inch, as compared with 4.67 lbs. when too wet for good plowing, and the same when in ideal condition. In this series 150 tests were made by Professor Ocock on each soil condition; hence the average is remarkably accurate. The deeper soil layers contain more moisture, which is probably as important an item as the proportionate decrease in cutting edge for deep furrows. Ocock's thesis experiments showed a gradual decrease in draft with an increase in depth except in one case, for which no explanation can be given. In dry corn stubble thirty tests at a depth of five inches averaged 4 per cent. lighter than the same number at one inch deeper. The accompanying table from this source shows the draft per square inch in five tests of each of six different plow bottoms, used on a single frame, in each of three different soil conditions at five different depths. All tests were on the same field in uniform soil, but at different dates.

DRAFT OF PLOWS IN ILLINOIS CORN STUBBLE

DEPTH	DRY	WET	IDEAL	AVERAGE ALL SOILS	RELATIVE DRAFT
4"	5.32	5.14	5.07	5.17	117.8
5"	4.84	4.84	4.90	4.86	110.2
6"	5.07	4.57	4.68	4.77	108.2
7"	4.78	4.49	4.46	4.57	103.8
8"	4.66	4.31	4.27	4.41	100.0
Average all depths }	4.93	4.67	4.67	4.76	108.0



Several other points might be noted, including a saving of 7.5 per cent. by lengthening the hitch with a 13-foot chain; the increase in draft noted in a previous chapter, due to the downward and landward suction of the plow point; and the slight increase in draft of wheeled plows on grades, but the factors already discussed are the most important.

A better understanding of the draft of plows would undoubtedly lead to greater profit and more humane treatment of animals. In old land the average draft per square inch of cross section probably ranges from five to seven pounds. For a furrow 6 x 12 inches, the total draft would be from 350 to 450 pounds, while the average durable working draft of a horse is found to be from one tenth to one eighth his weight. Three 1200-pound horses on such a furrow would probably strike the average farmer as a waste of horseflesh, but the result of too little power is to be seen in the wornout condition of the work stock at the end of the plowing season. A wagon of 3000 pounds gross load on a sharp incline gave only half the draft that a furrow 15 inches wide did on the level. An all-day pull of twice that, or three tons, uphill would be regarded as out of the question, yet two horses are frequently called upon to do as much in plowing. In consequence, one of several things must happen: Either the team must lose in condition; much more food must be supplied than is ordinarily required to generate a unit of force, since above a certain limit a lower percentage is assimilated; or the quality of plowing is lowered, which is the greatest loss of all.

## XXII

### DRAFT OF OTHER IMPLEMENTS

**M**EAGRE as are the comparative draft data on plows, they are ample as compared with those on implements of other kinds. Practically no draft tests have been made of modern tillage implements; hence, the draft can be approximated only by comparing the number of horses used on implements of different sizes. Outside of the plow the ordinary drag harrow, the disk harrow, and the clod crusher or pulverizer are the principal tillage implements used in the North. The following table gives a sort of comparison of these three on the basis of the horses used to pull them, allowing 150 pounds as the effective pull of each horse:

	DISK HARROW	DRAG HARROW	CRUSHER
Width, feet	8	20	10
Weight, total	580	320	1100
"    per foot	70	16	138
Horses required	4	4	4
Approx. draft	600	600	600
Draft per foot	75	30	60

The above comparison cannot be regarded as more than a rough approximation. Four horses are often needed to pull a seven-foot disk harrow with 16-inch disks, while the eight-foot harrow, with 16-inch disks, is also equipped with four-horse hitch. The more mellow the soil the greater the penetration; hence, the greater the amount of dirt moved. Sharpness of the disks is a factor in penetration, and a decrease in angle to the line of draft also increases the work done. Con-

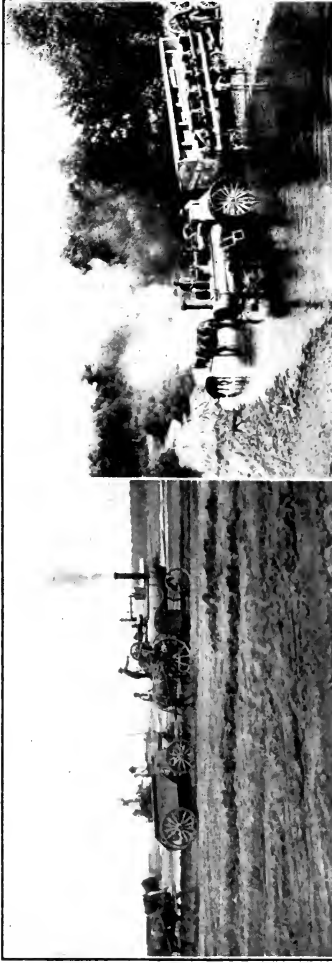

**THE GENERAL UTILITY OF TRACTORS**

**Building a railroad**

**Moving a gymnasium**

**Fording a stream**

**Threshing out the snow drifts**



sequently, an eight-foot harrow with disks at right angle to the tongue can be easily pulled over a hard road by one horse, while at the Iowa State College they have a photograph showing eight of their horses — eight tons of horseflesh — having plenty of exercise in moving two-disk harrows in a mellow cornfield. The condition and texture of the soil play as great a part in the draft as in the case of plows.

In stiff clay land a two-horse team, weighing 2200 pounds, can be used on a steel spike-tooth lever harrow, cutting fifteen feet. However, the teeth must slant well backward, the driver must walk, and it will take a good many trips over the field to get it into condition. To accomplish much in the way of pulverization the teeth should be set nearly straight and at least one horse provided for each five-foot section.

Crushers and pulverizers vary considerably in weight per foot of width. One authority says that rollers should not weigh more than 100 lbs. to the foot and should be at least 24 inches in diameter. Of course the greater the diameter the lighter the draft, unless the weight is increased to correspond, but at the same time the pressure per square inch on the ground is decreased. Ordinarily these implements average about 18 inches in diameter and weigh from 130 to 150 lbs. per foot. An internal-combustion tractor, which had been pulling six 14-inch breaker bottoms in North Dakota, was able to handle three 12-foot disk drills and three 12-foot sod crushers, weighing 1800 lbs. each. Allowing 60 lbs. to a foot in width for each, the total draft would be 4320 lbs. At the Winnipeg motor contest the same year the breaking plows averaged over 700 lbs. to the plow; hence the draft for six bottoms would check up very well with the amount just assumed for the drills and crushers.

The disk drill, and particularly the single-disk drill, is now practically standard. As a rule the furrow openers are spaced 8 inches apart. Three horses will usually handle a 12-foot disk drill, seeding a strip 8 feet wide. Allowing 150-lb. pull

to each horse, the draft per foot of width would be 57.5 lbs. Professor Davidson, of Iowa, obtained a higher draft than this, a single-disk drill with ten furrow openers, 8 inches apart, having a draft of 68.6 lbs. per foot of width. Drills usually place the seed about 2 inches below the surface; consequently the work of drilling and covering seed takes approximately the same power per acre-inch as the disk or drag harrows doing work as shown in the table.

Mowing machines are usually operated with two horses for a 5 or 6 foot cut, indicating a draft of about 300 lbs. A leading manufacturer places the draft from 190 to 325 lbs. for a 5-foot mower. Two other authorities place the draft at from 285 to 340 lbs. for the same width. The draft may easily be doubled by dull knives, tight boxes, or too low speed. The knives are not serrated as in the case of the binder; hence about three times the speed of cutter bar must be maintained in order to cut cleanly through the tough stems of forage grasses. The 6-foot mower will of course require more power than the 5-foot, but not in proportion to the extra cut. In one test, five mowers run in gear but not cutting showed an average draft of 154 lbs. While cutting the average was 268 lbs., showing that 57½ per cent. of the draft was due to the running of the machine. The actual work of cutting apparently consumed about 23 lbs. per foot. In an actual test of a 4½-foot and a 6-foot mower of the same make the drafts were 203 lbs. and 263 lbs., respectively. This shows about 34 lbs. of draft for each added foot cut. However, the extra weight of frame and the added size of bearings increased the draft somewhat. It is evident that the wide cut mowers are economical in the same way that the engine is economical when running at high percentage of its rating, less being wasted in internal friction.

The kind of grass cut and the thickness of stand have an important bearing on draft, but, owing to different speeds of cutter bar, different mowers show lighter draft in different grasses. In an experiment by Sanborn, in which five mowers

made twelve trial runs, all showed the heaviest draft on a  $3\frac{1}{2}$ -ton crop of timothy. Two showed a lighter draft on a  $2\frac{1}{2}$ -ton crop of alfalfa than on a field of wild hay, which was very thick at the bottom. The other three, running at higher speed, handled the dense stand of fine grass better than alfalfa.

Six-foot binders range in draft from 300 to 500 lbs., requiring three or more horses to pull them at a speed high enough to do good work. Professor Davidson quotes tests showing 314 lbs. as the average of two 6-foot machines, or  $5\frac{1}{2}$  lbs. to the foot. To some extent the same statement as to economy in cutting a wide swath might be made as with mowers. However, the binder must elevate and bind the extra grain at some additional expenditure of power; 12-foot headers require from 600 to 800 lbs., or from 50 to 70 lbs. per foot cut. A header binder of the same size will require from 100 to 200 lbs. extra to operate the binding attachment. More horses are more commonly used on binders than on mowers in proportion to draft. Since there are more opportunities for sluggish movement of the straw to clog the working parts, a high speed must be maintained. The average farm horse is able to maintain a pull of 150 lbs. only by reducing the net speed to two miles per hour or less. To maintain two and one half miles per hour, at which speed the machines work to best advantage, more power is required.

There are probably more data available as to the draft of wagons than any other piece of farm equipment. The height and width of wheels, the position of the load, the angle of traces, speed of travel, lubrication, character of road surface, grade, and many other factors enter into the question of draft of vehicles. The higher the wheel, the less the draft, in proportion to the draft of the total weight of load and vehicle. Road surfaces are never entirely level and wheels are continually encountering obstacles. The higher the wheel, the less the percentage of grade which each obstacle opposes. Consequently, less momentary force is required to lift the load over the obstacle. This process is constantly repeated; hence,

high wheels and smooth roads contribute to light draft. The harder the road surface, the less do the wheels depress the surface soil. Since the force pulling the load is constantly endeavoring to lift it to the surface, the effect on the wheel is that of constantly rolling up an inclined plane, the gradient of which is determined by the per cent. of the radius of the wheel which is below the surface of the ground. This fact largely accounts for the low figure of from 8 to 10 lbs. of draft per gross ton on railways as compared to 150 lbs. on ordinary dirt road.

The width of wheels affects the draft differently under different circumstances. In general the wide tire gives from 20 to 120 per cent. less draft than the narrow tire on the same size of wheel. However, when the dust is deep, or when there is a thin coating of mud with a hard surface below it, the narrow tire pulls easier. This is probably because the wheel must sooner or later sink to the hard surface and a narrow tire encounters less resistance. Again, where there is only one wide tired wagon in a community, and this wagon must continually travel in ruts made by narrow tires, the work of filling up these ruts plus that of carrying the load makes the wide-tired wagon pull harder.

Each rise of one foot in 100 adds 20 lbs. to the draft of each ton, including the weight of vehicle. On a good macadam road the draft per ton is only about 60 lbs.; hence, a rise of only 52.8 feet to the mile adds a third to the draft. The better the road, the worse is the effect of grade, since a greater load can be hauled on the level, whereas on the hill the action of gravity is independent of the ground friction. It is for this reason that railways spend immense sums in cutting down grades.

Road surfaces greatly affect the draft. Taking the draft on a plank road as 100, the draft on other surfaces in a certain test was as follows: Macadam road, 152 to 220; gravel road, 300 to 318; common dirt road, 300 to 509. The lowest draft on a plank road was 25 lbs. per ton, and the highest on a dirt road was 224 lbs. per ton. Other tests have shown up as high



as 700 lbs. per ton on soft ground; hence, it is hard to make a comparison of the draft of wagons with other implements. However, two horses can usually be depended upon to draw continuously about 3500 lbs. of gross load on ordinary country roads.

Lubrication is another important factor in the draft of all wheeled implements. Sanborn reports that a wagon weighing 3300 lbs. with load, took a pull of 294 lbs. with no grease and 243 lbs. where lard was used. Between these two, taking lard as 100, the comparative draft with other lubricants was as follows: Axle grease, 100.7; cylinder oil, 104.3; castor oil, 106.7; lubricating oil, 112.1; coal oil, 117.6. However, considering the small effect of axle friction as compared to earth resistance, the above results seem exaggerated.

The draft of wagons increases with the speed of travel. In an experiment in England the same load was drawn at varying speeds over the same road, which included a variety of grades. Taking the draft at four miles per hour as 100, the relative draft was 104 six miles, 109 at eight miles, and 115.8 at ten miles per hour.

Owing to the countless factors that affect the draft of implements, machines, and wagons, it is apparent that draft tests, under different conditions, are of little comparative value. Taken absolutely, however, they give a good line on what either a horse or a tractor should be expected to accomplish. A wider use of the dynamometer, in connection with the exercise of abundant common-sense, would undoubtedly result in more humane treatment for animals and greater service from traction engines.

## XXIII

### THE GENESIS OF POWER PLOWING

**F**OR nearly a century after James Watt had solved the secret of burning fuel to produce power, steam did nothing notable to relieve man's heaviest task, that of turning over the soil each year to produce a crop. Willing inventors were numerous enough, and sheaves of patent claims bore testimony of the efforts made to substitute iron and chemical energy for the plow animal's muscle. Judging from the bulk of the early ideas expressed in this manner, few men had even a faint conception of the enormous forces and resistances with which they would have to deal in the solution of the problem.

The earliest successful application of mechanical power to the plow seems to have been made in England, about 1850. A portable steam engine and a windlass were then used to wind up a cable attached to what was known as a balance plow, *i. e.*, a wheeled frame carrying two gangs of plows, one right hand and the other left hand, set facing each other. One gang was dropped into the ground and the other tilted out by the same motion, the plow being ready to start immediately on the return journey without being turned around. In order to pull the plow back and forth across the field, the cable was first passed around either a triangle or a quadrangle on pulleys. Two of the pulleys with automatic anchors were moved in parallel paths along opposite sides of the field at right angles to the furrow, the engine remaining stationary. The anchors moved alternately forward the width of the strip plowed, to guide the



## PIONEERS IN STEAM PLOWING

With walking plows in Ohio

With horse gangs in Minnesota

With disk plows in the Northwest. (Note the size of the crew)



plow as it passed across the field. This was known as the "round-about" system. Somewhat later a single traction engine with a winding drum was substituted for one of the movable anchors and the windlass. The great length of cable required and the clumsiness of the tackle hampered the work, and in due time a second traction engine similarly equipped was substituted for the remaining anchor. This form of cable plowing has been developed very successfully by English firms and is still used from one end of the world to the other.

Power plowing in the United States has reached its highest development upon the extensive areas of the Western plains. Owing to the size of the fields and the excessive cost of the cable equipment, the latter was never successfully introduced there in the common system of small grain culture. As early as 1870, natives of Kansas were startled by the appearance of an upright steam traction engine to which were attached a number of horse plows. Ten or fifteen years later steam plowing began to be common in California. About the same time, general substitution of the traction engine for horses in driving threshers stimulated the desire for mechanical power for plowing in the Central states.

Failure was the result of nearly every venture during these early years. The only engines available were of small size, designed more for belt power than for pulling. When enough common horse plows were hitched together to take up the power such an engine could develop, the outfit proved to be unwieldy, especially in turning. In addition to one man at each plow as before, it was necessary to have another to drive the engine and another with a team to haul fuel and water. There was no saving in labor; in fact, quite the reverse. The light, narrow cast-iron gearing had been designed only for moving the tractor from place to place with a light separator. Expensive breakage followed the attempt to transmit power enough through it to pull plows. The plows were neither suitable nor strong enough; the outfits had small capacity; the operators

were inexperienced; and the cost of maintaining a horse was so much less than at present that animal power suffered no real competition.

With the growth of grain farming in the West the demand for larger and faster threshing outfits resulted in a considerable increase in size of steam engines. These, however, were designed with reference to the work they could deliver through a belt, rather than at the drawbar; hence the growing use of these engines for plowing resulted in the same conditions as before. Steam plowing was generally regarded as a large farmer's fad, even by manufacturers, but the demand for a better plowing power became so insistent about the beginning of the new century that engine makers began one by one to comply with it. The first step was merely to increase the size of gearing, axles, shafts, etc., but at length the pressure and the outlook for profitable business led manufacturers to design plowing engines of better material and proportions from the ground up. The steam-plowing boom, which had waited only for serviceable equipment, was then on.

The steam-plowing engine, in less than five years, reached a high state of efficiency as compared with the former types. In large units it proved to be most economical, especially after suitable plows were developed. The power required for plowing a given area was so much greater than for threshing it that plowing engines too large in size for economical use at other work were soon in demand. Skilled operators were developed, equipment improved, and more uses found for engines. The practice of steam plowing was rapidly extended. Vast tracts of level territory were opened where the acreage was so great as to discourage the idea of turning it with single teams and horse plows. Prairies were tamed in a twinkling. Large areas which would otherwise have remained uncultivated were brought quickly into productiveness. They have since been cropped with a minimum of horse and man labor, which has constantly become more expensive.

The path was then clear for the gas tractor. The farmer had been educated to traction farming. The desire for economical motors of smaller size, the scarcity and high price of labor, the difficulty of obtaining cheap coal; and the limited supply of good water in some sections created the demand. Designers of all but the first few gas tractors started with the certain knowledge that their engines would have to meet the severest possible test — *i. e.*, *plowing*. In consequence not all the costly experiments of steam plowing engines were repeated.

The future of the gas tractor has been bright from the moment that the first practical machine was placed on the market. After they were once successfully introduced their manufacture increased by phenomenal steps. Standardization has proceeded with marvelous rapidity, and the gas tractor to-day stands ready for hard and lasting service, in less than half the years it took to make the steam plow even practical. It is now so far perfected as to be remarkably efficient, and is rapidly freeing itself from the charge of unreliability. Moreover, it presents a wide field for improvement, while both the horse and the steam tractor seem to have approached the probable limit of immediate perfection, and will progress much more slowly in the coming generation.

## XXIV

### SUBSTITUTES FOR THE TRACTOR

**W**ITH the coming of the internal-combustion motor interest in application of mechanical power to farm work has broken out afresh in all directions. The system of direct traction, wherein a self-propelling prime mover draws behind it the plows, binders, or other working devices, has, for the present at least, been accepted as standard by the American trade and public. The direct traction motor, which is built to resist the tremendous tug of a number of plows at the drawbar, is also best adapted for pulling the other field implements and machines, all of which have been developed for transforming an animal's straight pull into linear, reciprocating, or rotary working motion.

By linear working motion we mean a straightforward movement, such as we find in the plow or the harrow. The implement's peculiar shape is relied upon to produce the desired effect upon the soil. Reciprocating motion is seen in the cutting knife of the binder or mowing machine. The linear pull of the horse is transformed first into rotary motion by the drive-wheel, gears, etc., thence into reciprocating motion by a crank disk and pitman. Rotary working motion of the simplest kind is seen in the disk harrow, the cornstalk cutter, the alfalfa renovator, and the stubble digger. Here the work is done by wheels, which not only carry the weight of the frame, but are of the shape required for the work in hand. More complex rotary working parts are found in the cylinder type of hay loader and hay rake, in the hay tedder and the manure



spreader. Stationary machines, as a rule, use rotary motion, though, as in the threshing machine, some reciprocating parts are often added.

In Europe, and to a less extent in this country, great efforts are being made to develop substitutes for the direct traction method. Several schools of inventors have grown into prominence, each with a different idea as to how best to apply mechanical power to the soil. The majority advocate direct traction. Another large and well-established school would have the power stationary, or at least portable, the working implements being drawn back and forth by cables. A third group insists that motive and working power be com-

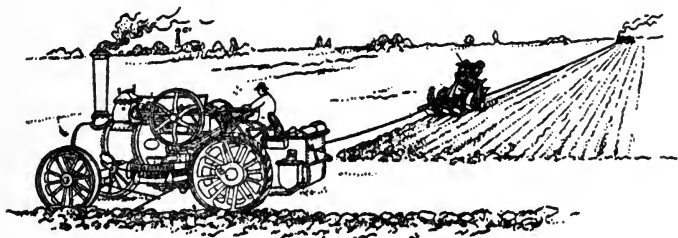

Cable plowing scene

bined in one self-propelling frame or unit, while a fourth advocates the use of animals for propelling the outfit and mechanical power for driving the working parts. Nor can we overlook entirely the efforts of men to replace the power of heat engines by electricity from some cheap and abundant supply.

#### CABLE PLOWING TACKLE

As we have seen, the use of a cable and winding drum for pulling plows is one of the earliest ideas in mechanical cultivation. A short cable, along which the motor propels itself by winding the cable around a drum mounted on the frame, has also been in quite common use for pulling engines out of diffi-

culties. Within the last few years several plowing motors based on the latter principle have been brought to the working stage, using a pulley around which the cable passes only once or twice; the cable otherwise remains stationary, fastened at both ends, or at least at the end of the field toward which the machine is proceeding. As the pulley is made to revolve by the motor, the friction between its surface and the loops in the cable becomes great enough to propel the outfit. The loss in slippage of the cable on the pulley is claimed to be slight. This system appeals forcibly to those who have seen how ineffectual at times are the efforts of any type of traction wheel and grouters to grip soft ground. One successful motor of this type was ordinarily propelled by traction wheels, but brought the cable into play automatically when the slippage of the wheels exceeded a certain per cent. This rendered the tractor available for use where it was impracticable to use the cable, as on roads.

The most successful application of power through cables is, of course, the double-engine and cable method of steam plowing. In this system steel cables, 80 to 100 rods long, are attached to the implement, which may be a balance plow, a cultivator, a beet-lifter, or a frame under which harrows, rollers, etc., may be attached. One engine remains idle, paying out the cable, while the other winds it up on a drum mounted on a vertical axis underneath the boiler. The traction wheels of both engines remain stationary while the cable is being wound. In this way the entire brake horsepower becomes available for pulling the plows, there being no loss through slippage or the movement of the tractor's weight across the fields. Slippery surfaces do not affect the tractive efficiency, and in many cases permanent roads along the sides of the fields insure firm footing for the traction wheels at all times. Another advantage lies in the absence of any packing of the soil. The shape of the field has less influence on economy than with the direct traction system, but owing to the length and weight of

cables required the use of the cable system is necessarily restricted to small fields.

The cable outfits are used to a great extent in beet and cane-sugar cultivation, being well adapted to extremely deep plowing. Bulletin 170, United States Bureau of Plant Industry, makes the following statement regarding their economy in California:

Plowing is done at a depth of 12 to 14 inches for sugar beets, and in heavy adobe soil from ten to twenty acres are covered per day. Light cultivation is done at a depth of 7 to 9 inches and deep tillage at from 14 to 16 inches, the cultivators being 16 feet and 10 feet in width respectively. Cultivating is done at a rate of twenty-five to thirty-five acres and harrowing at the rate of fifty acres per day. A special implement, lifting six rows of beets at a depth of 12 to 16 inches, is used in harvesting, and from fifteen to twenty-five acres are covered in a day when necessary. No time is lost in taking supplies, as the engines are stationary, and little time is wasted at the ends of the furrows, one engine being ready to start pulling as soon as the other finishes.

From five to eight men are used in plowing, including a foreman, two engineers, one or two teamsters, two plowmen, and a cook. From six to eight barrels of crude oil daily supply both engines. The expenses, not including interest and depreciation, are about \$30 a day, or from \$2 to \$3 an acre. In comparing this with the cost of operating direct traction outfits, the great difference in depth of plowing must be kept in mind. Interest and depreciation charges are heavy, though, the outfits are in use the greater part of the year. The investment for each outfit, including freight and duty, is from \$25,000 to \$30,000. The cables, which cost from \$600 to \$900 each, last from six to eighteen months in continuous use, and bad water destroys flues in from six to twelve months; otherwise the outfits are capable of long service.

In view of the heavy initial and operating cost, the use of this equipment is restricted to large enterprises. One ranch in California uses five sets of tackle in handling 10,000 acres of sugar beets, using horses only in seeding and hauling. Each outfit is said to displace 120 horses and the necessary drivers. Another outfit, operating eleven months in the year, handles 1300 acres of beets. Others are to be found in large vineyards, while a large number are used in sugar-cane culture in Hawaii. While these outfits are not suitable for use on a small scale, it would seem that a modification, embodying the numerous advantages, and adapted to more general use, might be produced in the United States and sold at a price within the reach of small operators.

The double cost of these outfits, the excessive wear on the expensive wire cables, the slow rate of work, and the lack of adaptability to large fields have greatly restricted their use. Internal-combustion outfits in imitation have never been developed to a wide extent, though there have been some recent developments along that line in Continental Europe.

## AUTO-PLOWS

The "automobile plow" — *i. e.*, a self-propelling, compact unit, capable of turning in small quarters — has a large body of advocates. Many experimental tractors, combined with plows hung directly under or on the frame, have been developed in different forms. The plows can usually be lifted clear of the ground and the tractor backed around to cut a square corner. On one of these machines a gang of plows is mounted between the drivers and the front wheels. Back of the drivers follow a harrow of special design and a clod crusher, while seeders also may be attached. The plows are shoved, rather than pulled, and one drive wheel must always run on the plowed ground. Auto-disk plows have been attempted by at least two or three inventors in this country, and several in Europe, but without marked success. The effort is made in some of the latter to have the plows transport the weight of the outfit as well as turn the soil.

Few auto-plows have reached the marketing stage. A motor adapted primarily to plowing, with plows combined in the frame, is at a disadvantage in performing other operations. A harvester, for example, cannot be hung under the tractor frame. If it be attached to the rear the strain is different, with a consequent upsetting of balance and probable loss of tractive efficiency. Doubtless we shall some day see for the small farmer a transferable power plant, with a base for it on each tilling and harvesting machine, which will be made self-propelling without duplicating the most costly part of the equipment — *i. e.*, the motor itself.

Another type of motor which propels itself by traction wheels is equipped at the rear with a chain-driven cylinder studded with steel hooks. The cylinder may be run at different speeds and depths, this, as well as the forward speed, regulating the amount and quality of work done. The tearing action of the cylinder leaves the soil in finely divided state, creating a

good seed bed without further travel over the ground. In this way, as with a traction engine pulling plows, disks, and harrows at one time, the traction wheels are always on solid footing, and there is less waste of power in propulsion. Several machines of this general character are now claiming attention abroad. One great objection to this principle, especially in the New World, is that the burying of vegetation is often the prime object of plowing. The cylinder would undoubtedly mix this trash with the soil more thoroughly than the plow, yet the lighter material may usually be found on the surface in considerable quantities.

A South Dakota college professor has attached to the rear of a wide-wheeled tractor a spiral tillage device which is actuated by a chain and sprocket. A Kansas farmer repeats an idea recently brought out in France — *i. e.*, a series of small plows connected by radial rods to a rotating shaft, each one imitating the action of a spade upon the soil. In another outfit, made in Italy, the ordinary plowshare is replaced by a pair of auger-like screws which precede the machine and are rotated in directions opposite to each other as the machine moves forward.

The use of electricity in plowing has been limited. The self-contained electric motor has never been perfected, at least in an economical way. To generate, by means of primary cells, the amount of power required even for very light work is out of the question, owing to the cost, bulk, and general unsuitability of the necessary batteries. The storage battery, which has been successfully used on small automobiles and trucks, is too bulky, costly, and expensive in operation to be practicable on a heavy plowing machine.

One development in this line is the self-contained "gasoline-electric" motor. In this the power of a gas engine is transformed by a generator into electricity, and this used to drive the machine. In some present motor trucks all four wheels are driven, with a small motor on each wheel. A storage

battery is needed to care for the peak loads on starting and elsewhere, thus reducing the size of engine required. The resulting combination is convenient and flexible for certain purposes, but very high in cost in proportion to power. Steering, reversing, etc., are accomplished without gears, and the great possible variation in speed could not be obtained as simply in any other way. There is, of course, considerable loss in transforming rotary motion into electrical energy and back again into rotary motion. However, a great deal of attention is being given to the development of this type of motor truck, and it is quite possible that some of its advantages may in due time be embodied in a plowing tractor.

Electricity from a central plant, wherever available at all, can usually be had quite cheaply, especially where there is abundant water power. Long-distance transmission lines bring the current from generators located at mountain water sites, thus using the "white coal" man has been wasting for centuries and now, in this country, proposes to mortgage to a few far-sighted monopolists. The use of this power for plowing at once implies the necessity for a much less mobile form of motor. It is obviously impracticable to stretch trolley wires and lay tracks at intervals across a farm field. Something on the order of the cable system must be employed with its added expense and other disadvantages. The simplest form necessitates two motors proceeding in parallel paths at right angles to the furrows as in the double-engine cable system. Such an outfit has already been put into operation on a small scale by an European inventor.

## ANIMAL - MECHANICAL TILLAGE

**A** FOURTH school insists that the prime idea in mechanical cultivation should by no means be to take implements, which have hitherto been drawn by horses or oxen, and make them self-propelling. Neither would it hold to the present idea of the plow to the extent of blindly retaining those of its characteristics which hinder the use of mechanical power to the best advantage. So efficient are the modern plow and linear motion in turning the earth that any suggestion of improvement takes root slowly. Yet many obstacles have arisen to prevent the wheels of the tractor from being as efficient as the four feet of the animal. No economical engine has the overload capacity of the horse. No horse has the economy of the stationary engine. It is by no means settled that soil may not be better pulverized by other means than the plow. Why not, then, some combination of the tractive advantage of the animal, the superiority of the mechanical motor for stationary work, and some pulverizing device best adapted to the power available for driving it?

The inanimate or mechanical motor should be used in every case where a simple, uniform, rotary working force is required, such as that produced by the horse in a tread or sweep power. Horses and oxen, dogs and sheep, even men and women are required in Europe to run stationary farm machines by muscle power. The mechanical motor in these countries will enable this work to be done ten times cheaper, and humanely displace the living muscle. In regions where animals are too few in

numbers, and in warm countries where the animal motor is very inefficient, only one course is possible — the utilization of the mechanical motor for propulsion as well as for the operation of machines. In temperate regions, however, especially where fields are small, and where moderate work the year round is actually essential to the health of animals, the advisability of mechanical traction in small units is more open to question.

The soil is the workshop of the plow or the cultivator. The arable earth forms the raw material to be worked, but, contrary to what happens in the factory, the machine must go to the material and work it up in its original place. If the latter work can be so regulated as to require a constant amount of power, a mechanical motor must, by its nature, be wonderfully efficient.

Distinction must be made between the effective work of the farm machine and its propulsion over the ground. As the movement of the machine is only an accessory operation and not productive, it is one on which the least possible effort should be expended. The productive force is that which cuts and turns the earth. With the animal motor this distinction is unnecessary, since the only movement of which the horse is capable — *i. e.*, forward or linear motion — has had to suffice for both the propelling and operation of the machine. Advocates of the fourth system insist that non-recognition of this distinction, and the consequent efforts merely to substitute a mechanical tractor for an animate motor, have delayed the solution of the problem of “moto-culture” ten or fifteen years.

To fit the foregoing analysis, a cultivator is being equipped with rotary working parts operated by a mechanical motor, animals being used to draw it. The force required to move it over the ground should not be great, as Yankee ingenuity has demonstrated in adapting mechanical power to harvesting in small units. The harvester, or binder, for instance, weighs only 1500 to 1800 lbs., which is not an excessive load for one large horse, and a very light load for two. A gasoline motor, either mounted on the frame or carried on a separate truck and



connected by a universal joint, operates the binder under the most severe conditions. Two horses easily pull the entire outfit, yet three to five horses are ordinarily used when the cutting and binding mechanisms are driven by the bull-wheel.

A combination tillage machine might be built light enough so that on a smooth piece of land two horses would pull it for ten to twelve hours per day without being abnormally fatigued. A 2-h.p. gasoline motor for traction could not replace these two horses, even on smooth ground. Taking into account emergencies, the losses by internal friction and slippage of tractor wheels, probably 6 h.p. would be necessary, and much more on grades. Animals may be allowed to rest from time to time for a fresh start on rolling land, and thus will negotiate steep grades without assistance. The gasoline motor gains nothing by resting, except a certain amount of momentum in the fly-wheel. The steam tractor, by using a surplus of steam and waiting now and then to replenish it, may mount surprising grades, but it is not so well adapted to use in small units. It is this difference which makes the animate motor really valuable for traction, because it has at its command, at a given moment, a motor power two to five times greater than the effort normally necessary. If the propulsion of the machine requires ordinarily 2 h.p. and at times 6 or even 15 h.p., then a mechanical tractor must be chosen with reference to the maximum requirements. A motor cultivator requiring at all times 10 h.p. for its effective work and 6 h.p. at the outside for traction, would work advantageously with a 16-h.p. motor, but one requiring a 25-h.p. motor where most of the time only 12 to 16 h.p. is necessary is not an economical proposition.

The inventors claim that a combined machine will as surely replace the four-horse plow as the band saw has replaced the back-and-forth motion of the band saw — as the grindstone has, in factories, displaced the whetstone and the file. They overlook the vital fact that, in the plow, the harrow and the ordinary hay rake, there is no lost stroke as with the saw, and

no energy is wasted in preparing for the next working movement. Furthermore, soils vary in their resistance to the plow, even in the same field, and to a much greater extent than grain before the harvester. To cut a furrow of uniform depth and width requires, therefore, an easy means of varying either the effective power, or else the speed of travel. It would not be easy to adjust the gait of a team to the amount of effective work being done upon the soil by an independent motor, nor will a small cheap gasoline engine work efficiently under a wide range of load.

On the whole, the argument is strongly suggestive of possible lines of development for small farms. Incidentally, this school, through its organ, *La Genie Rural*, proposes "moto-culture" as a term to designate the new methods of tillage that are being introduced. Owing to the confusing and poorly descriptive terms we now use — including "power plowing," "mechanical plowing," "steam plowing," "gasoline plowing," and "traction plowing," "mechanical tillage," "power cultivation," etc. — some short, comprehensive phrase such as "moto-culture" deserves wide employment in designating the whole field of mechanical power in relation to the soil.

## THE GENERAL PURPOSE MOTOR

**U**NIVERSAL moto-culture involves the solution of the small farmer's problem. Dreamers argue that the ideal farm is the little farm well tilled, because of the independent home life which it brings. The gas engine will come nearer solving the problem of mechanical power on this ideal farm than steam. The former is much more economical in small units, and in addition its convenience and the possibility of lightness which it brings will make its place secure on the small farm.

Unless horses continue indefinitely to increase in value, it is doubtful if the durable, all-purpose small tractor will ever be as cheap in first cost as the number of horses it will replace. Moreover, it can never be as economical in various kinds of work. In a team of four horses we have four units, which may be used either singly, in pairs, or all together. Each unit has an overload capacity, as we have seen, of practically 400 per cent. Therefore, we might have a variation anywhere from the  $\frac{2}{3}$  h.p., which one horse will develop continually and economically to the 10 or 12 h.p. which four acting together, might exert at one instant. The gas tractor will operate most economically between 70 to 95 per cent. of its maximum load. All its cylinders must act when one does, and there can be no such wide range of adaptability as will be found in the four-horse team.

It is doubtful if the really efficient farm tractor can be an all-round machine. The requirements of the farm as to

traction power are far too widely separated. No one has ever asked a single horse to be an efficient draft animal and a swift-going roadster at the same time. Even on the farm the proprietor recognizes the difference in type, and usually keeps one or more horses almost solely for driving, though available for auxiliary power in the field if needed. Why not then look forward to the time when the power requirements of the farm shall have been divided into two classes, the heavy and the light; when farm operations and farm implements shall have been standardized as to power requirements, so that two tractors — one heavy and powerful, the other, light and nimble — shall be able to find practically uniform loads in all kinds of work?

The admitted limitations to the small tractor's range of efficiency may lead to the development of combination machines, where animals provide the tractive force and motors the working power, especially for small operators. For ordinary enterprises the saving in time and human labor, with the gain in simplicity, make the direct traction system much to be preferred. Perhaps an improvement in direct tractors might be effected by developing auxiliary motors to be used only in ascending grades. This is already done in California with steam tractors, the auxiliary motors on heavy logging wagons being supplied with steam from the tractor. Similarly, road trains have been equipped in Europe with a flexible-jointed shaft, transmitting power from a single engine to the wheels of each wagon. In many cases it is a question of traction — *i. e.*, foothold, rather than of engine power, and these methods greatly increase the grip on the ground.

Some of the ideas and inventions of the various schools of power enthusiasts are not without merit, and under future conditions may have real commercial value. The rotary principle exercises a peculiar grip on the minds of the inventors, owing, perhaps, to the rapidity and completeness of the results which it may bring about. The plow, however, has best con-

served the animal's power, and the rotary and reciprocating motions of the harvester, with their loss in delivered power, have been suffered because there seemed no simpler way to produce the necessary results. Inventors still continue, nevertheless, to bring out weird varieties of rotary digging and pulverizing machines, earth saws, and the like, all designed to overcome the admitted defects of the plow. Most of these have run upon the rock of excessive power consumption. Animals, already scarce, could not be spared to draw them, since they attempted to do the work, not only of the plow, but of the harrow and the other pulverizing implements which follow. The cheaper and highly concentrated power of mechanical tractors has enabled the farmer to combine operations without a heavy cost for maintaining the power plant during idle seasons, and now more and more of these inventions are being brought to light. Few of them are practicable, but they show the trend of thought and the direction in which improvement of moto-culture will undoubtedly come.

The constant introduction of freak machines built around a single meritorious idea, now, as in the past, gives the public an unfavorable opinion of mechanical power for tillage. The tractor industry was a long time regaining the public confidence lost during the earlier years of development, when unreliable engines, mounted on unmechanical frames and traction wheels, brought many an early purchaser grief that he published far and wide. So long as inventors exist, and capitalists are willing for the sake of profit to promote the sale of experimental machines, the industry as a whole reaps the notoriety brought about by their failures. Mechanical power, however, is now so firmly established on the farm that its final popularity and general use will not be endangered by these failures, and invention along these lines is to be welcomed. The prejudice in favor of the horse is passing. Men have accepted the new order of things, and the problem now is to adapt mechanical

power and farm methods to one another in the way that will give the most useful results.

To do this it may be necessary to revise some of our methods of crop production. We are apt to look upon our present methods as the only ones, yet we must remember that the shape of the plow was not finally established until late in the first half of the nineteenth century; that our disk harrow, our sub-surface packer, and in fact practically all of our tillage implements and harvesting machines have been devised within fifty years. We must remember they were devised to make use of the only power that has been available for operating them, and that power was exerted in a linear direction. As a result of copying that power, we now have reciprocating engines producing rotary power at the crankshaft; transforming this into a forward or linear motion, in a tractor; that again into the rotary motion of the binder wheel, and even finally into reciprocating motion again as in the binder knife, before the power is finally applied to work. Going around Robin Hood's barn is walking the straight and narrow path in comparison.

Is the plow, for example, capable of further improvement? Or will it be superseded by a rotary mechanism which will perform the functions of the plow and harrow combined? Possibly something of this sort may supplant the direct tractor. The farm power plant must however do more to replace present methods than simply to prepare the soil. It may not be a wild dream that some day we may see a tractor with plows hitched under the frame, harrows or a pulverizing roller behind, possibly a rotary cylinder with pulverizing teeth taking the place of all three. On the side of the machine we may find a cutter bar, and on top a combined harvester for threshing and sacking the grain all at one operation. To be a complete success, the machine should also bale the straw and, if possible, seed the next year's crop at the same time.

The elements of all these ideas are now to be found on present gas tractors. We have auto hay presses, and auto threshers;

we have scores of auto plows; we have in England an auto mower; we have in Georgia an auto cultivator; we have auto transplanters and seeders, auto cotton pickers, auto road-rollers, and automatic machines for accomplishing practically every operation.

The beneficial results of combining operations are: First, to save time; second, by hastening the sequence of crop operations to confine them to the period when the most favorable conditions of soil and climate prevail, and avoid negative action on the soil between successive steps; third, to save trips on the plowed ground; and fourth, to make up a full and economical load for the motor, such as is found in the combinations of plows, harrows, disks, seeders, packers, and binders now to be found on our Western prairies. With horses the inability to concentrate power made it necessary to separate operations. With mechanical power there is no reason why we may not look for a recombination of all the various tasks which can take place at or nearly the same time.

He is a poor prophet who does not ask if in the end the tractor, which is now merely a substitute for what Thomas A. Edison calls the poorest motor ever built, will not be even more. It may combine in one frame a power-producing plant which is more efficient than the horse, and compact working mechanisms which are utterly impossible where the animal is used for power. If plowing were the only task on the farm, or threshing, or yet haying, some of these substitutes for direct traction might even now threaten the continuance of the latter system. No feasible method, however, approaches the use of the independent tractor in economy, simplicity, versatility and general efficiency. At present the problem of getting satisfactory machines to attach to the rear of the tractor seems to furnish complications enough, and the next generation will probably come into power before the tractor's supremacy over an indirect or a combined machine is seriously questioned.

The future will see a wider variety of equipment for the application of power to the work of the farm than would ever have been possible with animal power alone. Man has made no fundamental change in the horse in thousands of years of breeding and selection. In a single generation he has produced mechanical motors with much greater variation in speed than exists between the Belgian and the thoroughbred; with vastly greater difference in size than between the Shire and the Shetland; and with thousands of differences in design, materials, and construction that breeders have never been able to create in flesh and blood.



## XXVII

### BUSINESS MANAGEMENT IN TRACTION PLOWING

**T**HE success of a plowing outfit depends not only on the efficiency of the equipment, but upon the energy and business ability of the operator. It goes without saying that good equipment is the prime essential, but it is a common observation that all makes of engines and plows fail in incompetent hands.

The most successful use of the traction engine involves farming on a basis of quality rather than quantity. The biggest handicap to the popularization of engine power has been slovenly work. There was a time when steam plowing was synonymous with poor plowing and weed-infested farms. Prof. Thomas Shaw, of Minnesota, now in charge of over forty experimental farms for a great railway system in the Northwest, even now goes so far as to ask if manufacturers cannot bind their customers to a higher quality of work than the majority are doing. In the past this complaint might have been due somewhat to crude and clumsy equipment. Now, however, the traction engine makes quality in farming possible, owing to the fact that no work need be slighted for lack of power. The engine and plow equipment is excellent, and one by one other implements are being especially adapted for use with engines. Operators must now remember that there is more money in one acre of well-tilled land than in two where the owner's desire is simply to farm on a large scale.

A Saskatchewan official draws a parallel between the evolution of a large railway system and that of custom plowing

with tractors. On the start the demand was for mileage on the one hand and great capacity on the other. With growing competition grew the necessity for quality in order to secure business, and economy to insure profits. To the railway there have come better roadbed, better rolling stock, and better service. Close observation of details cheapened costs, and made these improvements possible. Better engines and plows are now making for quality in plowing, and close attention to oft-repeated expenses and profits is enabling men to maintain the more expensive equipment with satisfactory returns. Early progress in either case was more spectacular, but the later development is steadier and more effective. The manager of a plowing outfit must have an eye to the easiest profits. "Money saved is money earned." To reduce operating expenses is much more sensible and popular than to increase prices. It is much more scientific than to increase output, especially if, as is frequently the case, competition has forced the income down to the level of former operating expenses.

The operator who maintains an individual plowing outfit must use his ingenuity in adapting the expensive engine to as many other kinds of work as possible in the course of a year, thus dividing the fixed charges for interest and depreciation by as many working days as possible. The same thing is true of the custom operator, who, however, has the further difficulties of securing work in the face of competition, and collecting a fair price for his services from his customers.

A tractor contains the capacity for tilling so many acres, and the greatest economy lies in working these in the shortest space of time. In this connection we might call attention to a statement by a prominent official of the Illinois Steel Company: "There are so many tons of metal in the lining of a blast furnace. It is my business to see that they are gotten out as quickly as possible." Dr. Charles W. Elliot, former president of Harvard, said: "The replacement of machinery

goes on in this country at a prodigious rate. We Americans use the scrap heap oftener than any other nation, but we never yet used it quickly enough."

If an engine costing \$2750 has a life of 1000 working days, which are spent during the course of five years, the charges for interest, depreciation and repairs may be figured at \$3.52 per day. This is figuring the annual repairs at 2 per cent. of the first cost and interest at 6 per cent. on the average investment. If the same amount of work is spread out over eight years, the cost per working day would be \$3.77; if over fifteen years, \$4.35. These costs assume that the repairs will be the same in the life of the outfit, whether it lasts five or fifteen years. As a matter of fact, the longer the life, the greater the depreciation during idleness, and the greater the repair bill necessary to accomplish the same volume of work. Interest is based on the average inventory value, since depreciation is written off each year. This reduces the interest to a little over one half what it would be if based on the first cost, and the method is only fair, since depreciation and repairs are also charged. The longer the life in years for the same volume of work, the heavier the interest charge each day. It is therefore false economy to refrain from using an engine for any good purpose, simply to prolong its life, although every care should be taken to prevent unnecessary depreciation, especially during idleness. Nor can this paragraph be construed as an argument in favor of buying a short-lived engine to save interest, since depreciation is a much larger item.

In the case of the farm owner, the labor during rush seasons may be greatly reduced and much time saved, if fuel and other materials which are known to be necessary are purchased in quantity and hauled to the farm for storage, during seasons when no other work is possible. Operators will save much expense and loss of time, if the equipment is thoroughly overhauled prior to the beginning of the season, and worn parts replaced. A supply of the extras which are most frequently

renewed should be procured and kept on hand for emergencies. Better prices and more prompt delivery can of course be had during the slack seasons.

During the season, if repairs are needed, they should be ordered by wire and shipped by express, as every day's delay means a loss of much more than the cost of telegrams and expressage. In all cases when ordering repairs, operators should be careful to give a full description. They should ascertain also, if possible, the number of the part, the number of the engine, and the date when it was purchased. This in itself will save many agonizing delays which occur when insufficient data are given to enable the repair man at the branch office or factory to locate the desired part.

Every possible precaution should be taken to prevent accidents and delay. It takes approximately twenty-seven minutes every day of the year merely to do chores for one work horse; hence an hour a day is not an excessive amount of time to be spent by one man in looking after a machine capable of doing the work of twenty-five to thirty horses.

The plowing season is short, also the threshing season. The time of doing the work is the constant factor; the number and capacity of outfits, the variable factors. The more each operator accomplishes in a given time, the less competition he will have and the more service he can obtain from his engine. Counting only the items which are comparable to the overhead charges on the engine, that is, the interest, depreciation, shoeing, etc., we find that overhead charges amount to about \$30 per year on each horse. This is divided among about 1000 working hours, hence two horses have an overhead cost of 6 cents per hour and another cent can be added for the plow. A driver's labor costs 12 to 15 cents per hour. If the driver stops his team for fifteen minutes to adjust a plow, the loss is a trifle over 5 cents. Counting the daily overhead cost of a gas tractor as \$4.00, the plow cost as \$1.25, and the labor of two men as \$5.00, we have a total of about 1.7 cents per minute.

Fifteen minutes' delay to adjust a plow, or to find and tighten a loose bolt, means over 25 cents lost in labor and overhead charges, besides a greater loss from the acreage not plowed in season. With a steam outfit the loss is even greater.

Men buy plowing engines to cheapen costs and insure the handling of large areas. Capacity is at a premium. With a gas tractor capable of plowing 15 to 25 acres per day the most costly item may lie in saving the wages of one man. One man alone can frequently run an outfit, but the overhead expense on the outfit is often equal to the wages of two. Every moment of the engine's time that can be saved by having an extra man to handle the plows, change shares, run errands, or help about the engine, represents money saved in overhead charges, and in addition to the returns at harvest time. Not only that, but the presence of a second man makes work easier and more attractive to both, if not through the occasional exchange of places, then through the mere fact of companionship. In the past the isolation of the solitary, trudging plowman added immeasurably to the drudgery of it all.

In hiring labor, it is desirable to hire by the month, as in this case the owner has the services of the crew during the seasons of enforced idleness, without extra charge, while the very fact that laborers are paid by the month insures greater permanence. Board is usually furnished by the month, and there is no reason why wages should not be paid on a similar basis. By good management, the entire crew could be kept busy on rainy days, and considerable time may be well spent in overhauling the equipment. When wages are paid by the day, this work is too often neglected.

It is even better to pay a flat rate as a basis, and a bonus for extra performance. One large farm pays a flat rate per acre for the engineer and plowman, then allows the crew a bonus above the ordinary rate for the whole number of acres plowed, if the daily acreage exceeds a given amount. Thus the laborer not only gets full wages for extra output but a bonus which

is applied to his whole day's work. For instance, suppose an outfit averages twenty acres per day, the engineer getting 20 cents, guider and plowman 10 cents, and teamsters  $7\frac{1}{2}$  cents per acre. For fifteen acres the wages would be \$3.00, \$1.50, and \$1.13, respectively, and for twenty acres, \$4.00, \$2.00, and \$1.50. If the acreage goes above twenty, even slightly, a slight amount, proportioned to the minimum rate for each man, is added to the rate for the day. If the engineer got two cents extra the others would get 1 cent and  $\frac{3}{4}$  cent, which, on twenty-one acres would mean 42, 21, and 16 cents, respectively, added. This does not invite abuse of the equipment.

A good plan is to make the bonus effective only in case the man remains with the outfit until the close of a given season. As the season advances, the extra wages which might be secured from some other operator are not sufficient to meet the loss of bonus. One ranch of 25,000 acres in central Kansas hires about 120 laborers, paying \$20 a month as wages and at the rate of \$100 a year bonus, if the laborer remains on the farm until the close of the fiscal year, on September 30th.

Still another plan is to pay a very low rate of wages, amounting to approximately half the normal earning capacity of each man, supplementing this with a payment by the acre, which, for an average day's run, would pay an average total wage. Thus, a man worth \$2.00 per day would be paid \$1.00 per day and 5 cents per acre. His wages would seldom fall below \$1.75 and could be increased to from \$2.75 to \$3.00 with everything favorable.

The tractioneer should remember that the plows of to-day are designed to run at the speed a horse will maintain, namely, two miles an hour or less. At a higher speed a given plow may scour better, and will undoubtedly pulverize better, but there is also the danger of throwing the dirt too far, scattering trash, and unnecessarily increasing the power required to turn the furrow. Special plows, such as are used with oxen on the one hand and some foreign cable systems on the other, produce

the desired result with greater or less curvature of the mold-board. The same acreage may be secured by running at a speed of two and one half miles per hour with six plows, or at one and one half miles per hour with ten. In the former case the outfit must run ten miles farther to accomplish the same work. The engine speed may remain the same in either case, but at the faster speed the ten miles of extra travel must be endured by the tractor wheels with the additional strain upon rim and grouters. Both the engine and the operator must withstand two thirds more jolting, and the plowman, especially, must endure the discomfort occasioned by rapid progress, since the frame wheels of the plow are relatively small in diameter. These wheels and the gauge wheel, coulter and share on each bottom, must travel much farther in plowing an acre. The shares must be changed oftener, while the entire outfit remains idle. More trips across the field will be required for a given acreage, and there is the temptation at every turn to waste a little time. These speeds represent extremes, neither of which is adapted to present plow design. Until experience has proved that a higher speed is advantageous, and plowmakers have met the need with new plow shapes, the majority of tractors will be adapted to a plowing speed about equal to that of horses. Good management demands that the existing conditions be analyzed and no attempt made to force results which cannot reasonably be expected.

Every possible means should be taken to secure as large a volume of work as is possible with a safe rate of wear and tear on equipment. It is difficult to persuade hired crews to secure this volume by keeping the outfit in motion, the majority preferring to take long periods of rest and crowd the engine during the time it works. There is only one best speed for plowing with a given engine, and a good engineer can prolong the life of an engine by finding it. One well-paid man should be given full authority over the others, and made responsible not only for the amount of work done, but for the condition of

the equipment. Cheap labor is by no means economical, especially in the person of foreman or engineer. Not every engineer who can run a threshing engine can run the same engine successfully in breaking, while stationary and locomotive engineers fail more often than not at this "rough-and-tumble engineering." The duty of the foreman should be to cut down the time spent at standstill by every means within his power. Anticipating accidents is one profitable way of earning wages, and only the experienced engineer will be able to do this.

Cutting down the time required to take on supplies is another important item. Steam engines were formerly standing still about 25 per cent. of the time, for oiling and taking coal and water. Water may now be taken while the outfit is on the move, requiring from five to eight minutes for each hour. When it is necessary to stop for coal, as is the case perhaps four times a day, the work of taking it on, oiling, tightening bolts, etc., should be divided among the entire stop. With internal-combustion engines, the time thus lost is much less, although in a few makes of engine the use of cooling water is so excessive as to require a stop every two hours for this alone. A portable supply tank, with compartments for both fuel and water, is a time-saving piece of equipment in this case.

The custom operator must first of all be sure of getting a living price for his work. In some sections competition is so keen as to make this difficult, but thorough organization of the traction plowing operators should remove this difficulty. The cost of doing work must be accurately known before a fair basis of custom price may be had. This in turn requires the keeping of daily records of cost and performance, and this should be regarded as quite as necessary as intelligent management of the equipment itself. Daily records should show the number of miles traveled, or acres plowed; the total amount of fuel, lubricating oil and other materials used; the cost of labor and board; horse charges and incidental expenses. Cash



accounts should be kept in order that the repairs and other overhead charges for the season may be accurately divided among the total units of work. Accounts with each customer should show the date of the work; the total acreage; the custom rate and the dates of payment. Fields should be accurately measured and full value received for all work done. Blank forms for keeping these records are sometimes supplied free by the manufacturer. The custom operator should regard himself as a public benefactor, but not necessarily a philanthropist, and should be prudent in making concessions in the face of real or fancied competition. Prompt, and if necessary vigorous collections should be the rule.

The efficiency of the tractor must not be cut down by inadequate accessory equipment. This applies with particular force to the big steam outfit. For satisfactory attendance there must usually be at least one coal wagon, at \$75 to \$80 complete; a trap wagon for carrying the repair parts, tools, and odds and ends; and a tank wagon, costing anywhere from \$75 to \$200 complete. Chains, clevises, tools, and blacksmith outfits will usually cost from \$50 to \$125. Complete equipment of this sort will save many delays occasioned by the failure of some trifling part, and will save enormously on the time required for sharpening plows. Time and money have often been saved by sinking wells at intervals over a large ranch and using a small portable gasoline engine to pump water for the tractor. For plowing at some distance from headquarters it is advisable to have either a tent or shack for cooking, and possibly another for sleeping. The cook shack and sleeping van are frequently on wheels, and form part of the regular outfit which is taken from place to place. Thus no time need be lost in going to meals, and proper care of the men is made much easier. Either shack complete and mounted on substantial trucks will cost from \$200 to \$500, according to finish and equipment.

While the greatest need for mechanical power lies in plow-

ing, the use of a tractor on the farm is seldom profitable unless every effort is made to keep it busy during the remainder of the year. Conditions have changed remarkably in the last decade, and tractors are now in demand for a greater variety of work than was once thought within its range of usefulness. More satisfactory machines and implements for utilizing the engine's power have constituted one great factor in adding to the possible volume of work, and the most successful operator will embrace every opportunity thus offered.

## XXVIII

### THE TRACTION ENGINE IN DRY-FARMING

**D**RY-FARMING" is a relative term. It implies agriculture in sections where there is a normal scarcity of moisture during the growing season. Roughly, the dry-farming area in the United States lies west of the Missouri River in the North and the 99th meridian in Nebraska and Kansas, while in the South it includes the great plains area of Oklahoma, Texas, and the states to the West. It stretches westward to the Rocky Mountains, and northward far beyond the 49th parallel into the Northwest Provinces of Canada. Within this great body of land are the hundreds of thousands of dry-farms that lie outside the scope of practical irrigation, and on which unusual methods must be adopted to conserve moisture if these semi-arid tracts are to compete in any way with the green gardens under the ditches.

Through necessity, it has been demonstrated that the "Great American Desert" of the eighties is capable of producing the food of many millions of people. Rapid immigration and a demand for farm products far outrunning any possible increase through more intensive cultivation in the East, have made necessary the invasion of the semi-arid West, the adoption of new methods and more efficient equipment. The cattleman, using twenty-five acres to support a steer, has reluctantly given way to the settler. Yet dry-farming has until recently progressed slowly and failures have multiplied. High winds and lack of rainfall make work extremely difficult for animals to withstand during the hottest of the growing season. It has

always been found difficult to provide the variety of feed necessary for keeping animals in good working condition, and farmers have always been obliged to keep a surplus of horseflesh in order to make sure of a full quota during rush seasons. With the coming of mechanical power, dry-farming has taken on a new importance. Nowhere has the tractor found a greater range of usefulness than on the grain farms of the semi-arid West. It is particularly the dry-farmers' own and he is rapidly grasping its possibilities.

From time to time land was wrested from the range and broken up, only to present new and unsuspected difficulties. The very conditions essential to the conservation of moisture on the great plains, that is, a dust mulch and frequent tillage, make it almost impossible to prevent the hillsides from washing and blowing. Summer winds of sixty miles per hour carry the loose earth to bury vegetation and stifle man and beast. According to Prof. E. C. Montgomery, agronomist of the Nebraska Experiment Station, not over 10 to 20 per cent. of the land between the 99th and 104th meridians should be under cultivation. The remainder is good grazing land, and, used in conjunction with the cultivated area, will support a large amount of live stock. Modern knowledge holds, therefore, that the land really adapted to dry-farming is the level land best adapted to traction farming.

In all dry-farm tillage operations, there are three great problems: the conservation of soil water; the eradication of weeds, and the securing of proper physical conditions in the soil. Of these, the first is by far the most important. By the means employed to secure an adequate supply of soil water, the other ends are largely accomplished. So vital is this need that an enormous premium is placed upon prompt and rapid action at all times when the stock of moisture is endangered. The traction engine works swiftly. It is tireless. It relieves the farmer from rush and anxiety, and he has turned to it eagerly as the lever by which he can control the moisture situation.

This one advantage, capacity, has made him master of his environment. Were there no other consideration in its favor, the tractor would still hold an important place in dry-land agriculture. Methods vary with conditions and with people. Each section gains its ends independently. Yet into every part of the great semi-arid plains the traction engine has found its way, and proved its usefulness. A review of farm practice in dry-farming districts reveals no condition where it is not a most useful servant.

Dry-land agriculture has its degrees in dryness. There are regions having from five to ten inches of rainfall annually, where, with the best methods of soil tillage and moisture conservation, a crop may be raised no oftener than every other year. There are regions with from ten to fifteen inches of rainfall, where two crops may be grown in succession on the moisture stored up during a fallow year, plus that which is precipitated during the two growing seasons. Then there is the dry-land agriculture in which, with eighteen to twenty-two inches of rainfall, as in western Nebraska and Kansas, a crop may be grown every year. Rainfall is not the only factor, however. In the northern sections the evaporation is much less than in the southern, and an area with a rainfall of thirty inches in Texas or Oklahoma may entail drier dry-farming than one in Saskatchewan with half the annual precipitation.

In western Canada, the winter temperatures are low, and the summer season short. Evaporation is not so rapid as farther south, and crops may be grown successfully with much less rainfall. In breaking the virgin prairie, it is customary to allow the grass to obtain a good start, then to break it rapidly, as shallow as possible. By plowing only two to two and one half inches deep, the crown and the roots of the grass are separated. The long, gently curving moldboards of the breaker plows turn the sod upside down, leaving the surface in smooth, ribbon-like furrows. The best farmers roll the land immediately, so that no large air spaces may be left between

the subsoil and the furrow slice, and the sod is then in condition to rot with the greatest despatch. In from four to six weeks, the land is plowed again, this time at a depth of four inches or more. Disking and harrowing follow to prepare the seedbed and form a dust mulch on the surface, thus conserving the moisture for the following year's crop. The work of breaking and "backsetting," as the second plowing is called, must be done in the heat of the short northern summer. Daylight lasts over all but a few hours of the twenty-four. Work presses, but the severe toil of the horse must cease after eight hours, ten at the outside. He must have food and rest when needed most in the field. In this emergency, the traction engine stands ready to do the work of two or three shifts of horses. Not only does it do the work more cheaply, but, and this is more important, it does it exactly at the right time.

In the wornout lands of the nearer humid West, farmers have found that summer fallowing, or resting and cultivating the land a year between crops, gives new life to the soil. Scientists tell us that the bacteria of the soil make available some of the locked-up nitrogen, converting it into nitrates which plants can assimilate. Wasteful methods have made this necessary on some of the greatest wheat lands the world has ever seen. Summer fallowing under humid conditions is a confession of extravagance. In dry-land agriculture, it is a periodical necessity. Referring to average prairie conditions, the Minister of Agriculture for Saskatchewan stated, several years ago, that "bare summer fallowing is becoming, and indeed in many parts had already become, the very foundation upon which successful wheat culture is based and profitably carried on. The practice of summer fallowing is usually associated in the popular mind with the restoration of fertility; but not so in the West. Conservation of soil moisture is the primary object of bare fallowing."

In summer fallowing, two systems may be followed: either to plow the land early after the weeds have once germinated,

and then keep it constantly cultivated, or, where the land is clean, to plow it late and give it no further cultivation. The former is of course the more desirable method, as the weeds are destroyed as fast as they appear, the surface mulch is maintained, and no moisture is lost. However, with the ordinary number of horses kept on such farms, weeds often grow faster than they can be kept down.

Lovers of dumb beasts who pity the overloaded cart horse of the city streets, may well pity the patient, willing farm horse, in summer fallowing time, doomed to long, weary hours under the dry glare of the Western prairie sky, dragging a relentless load through the choking dust and heat. The hotter and drier the season, the more intense the energy which must be applied to retain the precious fluid. Again and again, by day and by night, cultivation must go on under extreme pressure. In the hour of need extra horseflesh cannot be had at any cost, and mere brute flesh and blood has neither the power nor endurance to meet the tremendous emergency. With the traction engine, the land can be gone over swiftly, and where necessary, the acreage can be doubled at night. Weeds then have small chance to rob the soil of the moisture and the soluble plant food made ready for the following crop.

It is a curious fact that in fallow ground rain may cause a loss of moisture where abundant power is not available for cultivating. A slight rain may penetrate only to the depth of the dust mulch, causing it to run together and establish capillary channels connecting with those in the subsoil. The evaporation during the middle of the summer, when these showers may be expected, may not only be great enough to remove the rain which has just fallen, but a large part of that which has been so carefully hoarded below the surface. It is practically out of the question for the farmer to maintain horses enough for such an emergency but by crowding his engine to its full capacity, he is able to reestablish the mulch before the mischief is done.

In the Columbia Basin of Washington, Oregon, and Idaho, the annual rainfall is as low as eight or nine inches. Here the usual practice is to summer fallow, and follow this with winter wheat. After the fall harvest, if the ground is quite free from weeds, it is possible to plow and leave it rough and cloddy without further treatment until the following spring. It is then in excellent shape to hold the soil and snow from blowing, and to allow rain and melting snow to penetrate. Trash thus has a better chance to decompose and the rains tend to settle the ground. However, if the land is weedy, the better practice is to use the tractor to disk and harrow the ground frequently after harvest. Plowing is then done in the spring for the summer fallowing, or for the spring crop if one is sown. In some sections of this Basin, near the mountains, the rainfall is sufficient to allow two crops between summer fallows, a winter crop followed by a spring crop, or two spring crops in succession.

There are sections in the State of Washington, where the soil is a volcanic ash, or pumice, of such loose, gritty, character that a traction engine, regardless of make or construction, is speedily worn out. Into this district many have been introduced, all meeting with the same difficulty. One would expect land owners to become discouraged, but on closer investigation, it is found that the violent storms of lava dust which play havoc with even the heaviest parts of traction engines make the use of horses during such times almost out of the question.

In the Dakotas and Montana new land is sometimes broken to a depth of five or six inches to avoid the drying out of the furrow slice which accompanies the method of shallow breaking and backsetting. Authorities like Professor Shaw affirm that the latter method makes it next to impossible ever to obtain a seedbed deeper than the original year's plowing, while with deep breaking and proper tillage there need never be a crop failure in either state. With deep breaking — *i. e.*, at least six inches — a fair seedbed may be obtained at once, though at an enor-



mous cost for power, and its depth increased at will in successive seasons. Those who follow this method usually pack, disk and harrow the new breaking thoroughly and put in a crop of flax the same season. The following year the stubble is well disked and harrowed, and a spring crop put in without plowing. The original surface soil is eventually brought again to the top and mixed with the other layers, but not until the old vegetation has been decomposed under the influence of the moisture which this system retains.

New and more fertile farms underlie the old, and farmers are adding to their acres by doubling the depth of plowing. Not only do they double the feeding ground for the roots of wheat, but they more than double the moisture holding capacity of the soil. The dust mulch, and the crust which forms just underneath it, may render four or five inches of the top soil unavailable for the support of plants. Eight-inch plowing gives, then, from 100 to 200 per cent. greater volume of cultivated soil and moisture reservoir than six-inch plowing, and ten-inch plowing places the soil water permanently below the evaporating influence of the sun and air. Animals, already limited in number by the crop-cycle which enforces a long, expensive period of maintenance each year with no return, cannot profitably be kept to do this increasingly difficult work. Only the insensate mechanical motor combines the strength, endurance and economy of maintenance necessary to coax satisfactory yields from this region of fertile soil and uncertain rainfall, and convert them into large net profits.

Further south, in western Nebraska and Kansas, with a rainfall of eighteen to twenty-two inches, there is reasonable assurance of a yield only every two or three years. Although the moisture may be sufficient, insects or high winds may spoil the crop; consequently, the usual practice is to put as little expense on the land as possible. The loss in case of a bad season is then less, and the yield in a good season compares favorably with areas under more intensive cultivation. Land

values and rents are low, hence from a business standpoint, the practice seems justifiable. However, the better class of farmers are realizing that with better equipment and cheaper methods they gain in the long run by applying more intensive cultivation. The traction engine has greatly cheapened the cost of the necessary tillage operations, and added to the certainty of their execution. It is, therefore, being adopted by farmers who prefer to make some effort of their own rather than trust entirely to providence.

In the great Southwest, the hottest and driest of the dry-farming regions, the only plowing that can be done economically during the greater part of the year is with the traction engine. It is at its best in the hottest weather. Heat is its very life. The steam engine produces its steam more economically, the internal-combustion engine its gas more perfectly, in the highest temperatures. The mechanical cooling apparatus of the latter removes the enormous handicaps placed on that other internal-combustion motor, the horse. Two thirds of the muscular energy consumed by the animal during work is given off as waste heat. Nature's cooling apparatus is unequal to the task in the heated zones. The temperature of the animal rises quickly to the danger point, and work must stop. But not so with the tractor. Let the sun shine mercilessly, let the ground dry and bake; disk plows will penetrate it; its very solidity aids the traction wheels to transmit more power to the plows; heavy rollers or crushers drawn behind the plows crush and pulverize the soil, the harrow smooths and stirs the surface, and the bare field has become a seedbed. Even after the crop is up and growing, light cultivation adds enormously to the yield by breaking up the dry crust which grips the young plants. With the tractor the farmer may thus cover two or three sections twice in the growing season, a task impossible with teams.

In the humid sections the weight of enormous steam tractors is occasionally a detriment on account of the packing of the

moist soil. To the good dry-farmer this appeals as an advantage, for packing the soil closes up the air spaces in the lower half of the furrow and thus prevents a loss of moisture, besides leaving the ground smooth and firm to facilitate harvesting. The firm earth conducts heat more rapidly, and packed subsurface soils warm up more quickly in the spring. Too often this work of packing is neglected on account of the extra drain on the energy of the work animals. The heavy tractor's own weight and its ample power remove the difficulty.

It is thoroughly established that the disk should precede, as well as follow, the plow in dry-land agriculture. The mixture of chopped stubble and loose soil thus thrown to the bottom of the furrow forms a perfect union with the subsoil, in contrast with the big, dry clods usually plowed under. Capillary connection with the subsoil is more quickly reestablished, the deep moisture rises, and decomposition of the buried vegetation is hastened. Lack of time and power usually prevent the practice of this valuable method. With teams, this operation must be done separately, but to owners of traction engines the addition of disks behind the plows is a mere detail.

No manageable team can perform more than one operation at one time. With horses seeding must wait on the work of the plow, packer and disk — plowing on the completion of the harvest. Sun and weeds draw moisture from the unprotected soil in the meantime. But the harvester may precede the tractor, the disk or plow may follow, and in an instant the ground passes from the shadow of the standing grain to the shelter of the earth mulch. Instead of separate trips for the plow, the roller, the disk and the harrow, the engine accomplishes all at once. Or the plow, the packer, the disk and seeder may work as one, to give the sown seed every advantage of moisture and time for growth. Instead of countless footsteps, each sinking deeper as the soil is made more mellow, the path of the tractor is made but once. Instead of a loss of power in traversing the soft ground, there is a fast grip of traction wheel on

firm earth. Instead of acres baking in the sun and air as they await the moisture-saving harrow, there is a swift and easy crumbling of the soil, a quick pressing of the earth back to its place and a protective mantle of dust to guard the treasured moisture. Measured in moisture or in money, the cost is less than by the former methods.

From the moment spring work begins, moments are precious. The grain which is sown to-day may yield a fourth more than what we sow to-morrow after a day's rapid loss of moisture. Two weeks' difference in time of seeding often spells the difference between glowing success and complete failure. At harvest time the early-cut grain contains a greater percentage of gluten and brings a higher grade and price on the market. Early threshing saves deterioration of the crops through exposure, and the early bird at the railway station catches the cars before the annual shortage. The tractor can plow fifty acres in twenty-four hours, disk or seed a hundred, harvest two hundred. It will thresh 10 acres — 200 bushels — in an hour, and at one trip haul two carloads to the railway. The searchlight of the engine gleams through the dark hours of the night while the tired horse rests in his stall for the work of the morrow. Even threshing, which has been confined to the time between dawn and twilight, may now continue through the darkness under the glare of electric lights. Current from a small motor and a portable lighting plant thus doubles the service of the farmer's equipment and lessens the overhead cost of farming.

The handling of the drill is work for the four-horse team — play for the tractor. Another team must follow the drill to draw the packer, another to harrow — three teams and three men. Three times three teams and three men must cross the field to equal the work of a small tractor and two men, with drills, packers, and harrows in tow. Where seeding follows quickly after plowing, a disk ahead of the drill wipes out the wheel tracks of the engine and mellows the soil; the drill drops

the seed at a given depth; the packer firms the earth around it to bring moisture for quick germination: and the smoothing harrow levels all and leaves the surface mulch. To-morrow the seeding is done. The extra teamsters must be dismissed to await the harvest, the horses fed and cared for against the day they will again be needed. The tractor needs only shelter, and not always is given that.

Inaction softens the muscles of the animal, but at harvest time the engine comes forth from its shed ready for the hardest work. For each horse on the binder there is a foot or so of cutterbar; for each five horses, a driver. For the engine there are forty feet of sickles, one driver, and two or more men to watch the binders. The engine in twenty hours may travel thirty to thirty-five working miles, and cut nearly five acres to each mile traveled. The grain may be cut neither too early nor too late, the ground disked to check needless exhaustion of the soil moisture, and the entire task completed before the toiling horses have bound the grain out of the way of the sun and storm.

Dry-farming conditions require, most of all, a means for rapid work when work is needed. The traction engine as a factor in dry-farming has thoroughly demonstrated its usefulness. It does its work rapidly, enabling the farmer to keep the upper hand of unfavorable conditions. It makes possible the effective conservation of moisture, the thorough eradication of weeds and the maintenance of superb physical condition in the semi-arid soils. It reduces the cost of operation to such an extent as to create a new and important source of profits, as compared with earlier systems of farming. A saving of from two to five dollars an acre by the use of a tractor in crop production represents an enormous percentage where the total yield may not be more than twelve to twenty bushels per acre. What is true of dry-farming is true also of other types, for in the last analysis dry-farming is merely good farming enforced by stern necessity.

The auxiliary equipment for use with tractors in dry-farm-

ing operations depends, of course, upon a host of local conditions. After the ground is once broken, a gas tractor of 30 actual tractive horsepower will be able to handle on the average eight to ten 14-inch stubble bottoms in plowing. This, at a net rate of  $1\frac{3}{4}$  miles of furrow travel, would give from two to two and one half acres per hour. This is fair capacity since it has been found that the average plowing outfit actually makes about sixteen to eighteen miles of furrow travel in a day of ten hours, after deducting for turns and all delays. Probably the eight bottom plow, equipped with both stubble and breaker bottoms, is the most convenient for this size of engine, as on lighter soils, the extra power of the engine may be taken up by a load of harrows, etc. Probably two thirds the operators, at least one half, disk or pack the ground while plowing.

In case the plows are not followed immediately by harrows, a combination of soil-preparing implements consists of four 8-foot disk harrows, at \$30 to \$40 each; six 5-foot sections of spike-tooth harrow, at \$6 each; three 11-foot rollers or crushers, at \$35 each; and three 11-foot grain drills, at about \$90 each. It will be noted that in every case except the plows, the total width of each set of implements is about two rods, so that any combination can be used readily. At the same rate of travel as before the capacity of the outfit would be practically seventy acres for a ten-hour day. Each disk harrow or crusher will take about 4 h.p.; each drill 4 to 5 h.p.; and each five-foot section of drag harrow about 1 h.p. These figures are for fairly heavy soil and it will be found in many cases that a combination of implements can be handled, which on the above basis, would require considerably more than the rated horsepower of the engine.

From three to five 8-foot binders, which will cost about \$140 each, can be used for harvesting on level ground, with a capacity of seven to eight acres per hour. It is necessary to provide a special binder hitch, which will not only allow easy turning but will secure perfect alignment of the binders so that

each will cut a full swath. The number provided will, of course, always be one less than the number of binders. On rolling ground the number of binders is limited by topography rather than the power of the engine, the larger number of binders having a tendency not to cut full width on side slopes. One type of patent binder hitch, costing about \$35, has added from ten to fifteen days to the annual service of many a traction engine in the West.

The header, a wide machine that cuts the wheat stalk close to the head and elevates it without binding, has much greater capacity than the binder. It can be used profitably only where the absence of storms allows the grain to remain on the stalk until fully ripe. One of these can be quite successfully pushed ahead of a small tractor, being pushed ahead. In some cases a larger engine will use a header in front, and plows or disks behind.

The combined harvester cuts, threshes, and sacks the grain at one operation. This machine, drawn by a large steam engine, may place from 75 to 125 acres of wheat in sacks ready for shipment, in a day of twelve hours. The disadvantage is that the crop has little protection from unfavorable weather. Rain may beat it down and shell out part of the grain, or wind may place it beyond the reach of cutting. Weed seeds are scattered back upon the ground by the "combine" and distributed from field to field, hence the essentials of good farming are harder to observe.

For threshing by the ordinary methods, separators are made in sizes adapted to practically all sizes of plowing engines, except the very largest. A large separator of common size, fully equipped, costs in the neighborhood of \$1300, and has a capacity of 1500 to 2500 bushels of wheat per day. Eight or ten wagons will be needed in threshing and hauling. These will cost \$100 to \$125 each when equipped with a straw rack and a 100-bushel grain box. The whole train may be hauled at one trip by the tractor, delivering two carloads of grain to the car or elevator.

At the present time, no general recommendation can be made as to the type of traction engine best adapted to dry-farming. In business of any sort, the dominant idea in the beginning is the matter of capacity. Where a great amount of work must be done, and rapidly, the net profits will sometimes be greater by using a more expensive method of operation. As dry-farming develops, the matter of economy of operation will become more important and equipment that is now profitable may have to be cast aside.



## XXIX

### TRACTION FARMING IN THE CORN BELT

**I**N THE great Northwest it is now conceded that the large grower of cereals must rely on the tractor to keep abreast of his fellows and the world's demand for bread. But down in the corn belt, where grandfather's methods are modified but slowly, the economy of the tractor and its wonderful message to humanity are being appreciated less fully. It is the corn belt farmer with from a quarter to a half section of land who is backward in adopting mechanical traction.

Even now, on some corn belt farms, stationary and traction motors of myriad kinds are performing nearly every sort of farm labor — plowing, seeding, harrowing, rolling, reaping, binding, threshing grain, grinding corn, filling the silo. They are hauling manure, shredding fodder, loading hay, unloading grain, milking cows, shearing sheep, drilling wells, grading roads, running spray-pumps to protect the fruit trees — even doing chores by carrying water and sawing wood. The gasoline engine adds electric light to the conveniences of the farm, and an automatic water-system instantly brings fresh water sparkling from the well with a pressure equal to that of the city main.

The farmer's wife on such a farm needs but to turn a wheel, throw a switch, twist a stop-cock, and be saved her hardest work. Butter is again made on the farm and not in the factory. The motor runs the cream separator and churn, dispensing with the labor of the milk cellar and its endless array of pans

and crocks to be washed. It gives new speed to her sewing machine. On sweeping day it saves her health and strength with a vacuum cleaner. It runs her washing-machine and mangle. Through a dynamo in the electric fan and the flat-iron it brings her blessed relief from the fiery heat of the range on ironing day. It is her ready helper in the kitchen. And all this takes no account of the promise of new inventions. The tractor dispenses with the raft of hired hands required to care for and drive teams. With the elimination of this constantly changing gang and the equally unreliable hired girl necessary to cook and wash for it, the atmosphere of the household grows purer, its tone higher. The farmer's wife and daughter have time to indulge in those feminine touches which make the home — to enjoy pleasures which, added to the naturally healthy environment, make life worth the living.

The live farm boy realizes instinctively that this is a mechanical age — an age of power. He sees it in the autos whisking by on the country roads, in the gasoline engine which displaces a neighbor's windmill, in the sputtering motorcycles on which the city youth dashes madly about the streets. The tractor appeals to his inborn sense of mechanics and fills an aching void in his life. He yearns for the opportunity to grasp it, to guide it, to see its cold metal parts transformed under his direction into a living, throbbing mechanism — to see the familiar dirty lamp oil blossom into power for lifting the weary burden of his hours of toil. This yearning gratified, his bosom swells with the engineer's new pride of mastery over the forces of nature. Only the farmer himself, often broken and bent from his victory in the unequal struggle with the soil, fails to enthuse over the new order of things.

The tractor has its place on the corn belt farm, as surely as in the great wheat belt. With the corn crop, the crisis lies in the work of preparation. The harvest is not rushed. The crop does not spoil easily. If it is not gathered in one way it will be in another. Cultivating, which is still the almost

undisputed province of the farm horse, is spread out over many weeks of leisurely nibbling along the corn rows. We have seen the wonderful opportunity for multiplying the corn yield by deeper plowing, though plowing is already the greatest problem of the farmer. With horses, plowing must be begun early and finished late. But the work of preparation requires haste. Uniform plowing, uniform preparation, and uniform date of planting result in an even crop all over the field, and add quality to the product. In a humid climate the ground should be left until in the proper condition and then made ready with all possible haste. In a dry climate the thoroughness of preparation is even more important. A Kansas farmer, formerly at the head of a Government experiment station in the Panhandle of Texas, says that only the corn crop that has a good start can mature nicely after the idle period which is inevitable during the summer drought. A crop that goes into the resting period in a backward state will not survive and bring forth a respectable yield. Deep plowing and a perfect seedbed are fundamental aids to a good start.

The following authentic record of a field of corn in Ohio up to the point of harvest shows the distribution of labor in terms of one horse's time:

	HORSE HOURS	PER CENT.
Plowing	13.20	31.20
Disking	3.86	9.10
Harrowing	4.14	9.77
Rolling	1.15	2.70
Dragging	5.38	12.70
Planting	1.84	4.35
Cultivating	12.79	30.18
	<hr/> 42.36	<hr/> 100.00

Except for cultivating, plowing takes by far the greatest number of hours and is the most severe work. Had this field been plowed eight inches deep instead of six, the percentage of time and power required would have been much increased.

The tractor adds capacity to the farmer's weapons and the work goes on at top speed. All the work of soil preparation up to planting, or nearly 66 per cent. of the hours required up to the harvest, may easily and quickly be done by the tractor.

For some operations the operator cannot depend on his animals, and for those jobs the live farmer wants power when he wants it, not when the other fellow is through. Even on the farms where there are plenty of horses, how often are the shredding and shelling delayed until the nasty fall rains and snow set in, while an individual outfit could have finished in nice weather. Corn is put into the silo either too green or too dry for lack of an engine at the proper time; top prices missed for want of means to rush stuff to market; and roads allowed to go to pieces for want of power to work them in the spring, when they need attention most. There are dozens of things that a tractor can do when regarded as something more than an ornament. It can pull mowers, haul hay to the stack, bale the stack and haul the bales to town. It can economically do everything to raise corn except the easy work of planting and cultivating, and in addition it will run any one of the half dozen machines for putting the corn into more convenient shape for feeding or market. It can handle every operation connected with small grain crops. With the individual threshing outfit more than one small farmer throws off the belt and, using a big rack, goes after a big load of bundles with the tractor. Thus, three or four men and a team to haul grain do the threshing instead of the usual big, hungry, dirty crew.

The tractor costs much less than the horses that will equal it in power. If both are worked constantly at full capacity, the tractor will last the longer. It is not subject to disease and death, and if seriously damaged can be replaced piecemeal, while the horse is permanently out of commission. Repairs on a well-built tractor are less than shoeing and veterinary attendance on the horses that will accomplish the same volume of work. Overhead charges therefore are less on the machine

Kerosene for fuel costs less than feed. It can be had at all seasons with little variation in price, since the oil companies are untiringly refining great quantities of it as a by-product of gasoline. Since the average corn belt farmer is close to some town, he can make a quick trip and return with enough fuel to last two weeks. Hay and grain are produced but once a year and must be stored. This gradually adds to the cost and price of feed which is always highest when horses require the most — *i. e.*, in the spring and early summer. Economy requires a farmer to store a year's food supply for his horses out of every crop.

In southeastern Minnesota, according to Government figures, the horses on a number of diversified farms each consumed 5213 pounds of grain and 7073 lbs. of hay annually during the years from 1905 to 1907. Supposing corn and oats to have been fed in equal quantity by weight, and assuming prices of 50 cents for corn, 30 cents for oats, and \$8 a ton for hay, one horse's feed for a year would cost \$73.89. These horses averaged 948 hours of work of all kinds per year, hence each ate 5.5 lbs. of grain and 7.46 lbs. of hay, costing 7.8 cents for every hour spent in harness. For 1000 hours of hard work a tractor equivalent to fifteen horses would consume about 3000 gallons of fuel. Kerosene may be had at 3 to 3½ cents at the refineries, and at the country towns in barrels for 5½ to 7 cents. At the latter figure, 3000 gallons would cost \$210 and the tractor's fuel would cost less than three times as much as one horse's feed. Even if we add \$75 a year for lubricants and minor items, the difference is enormous.

In these days of high lumber prices, the storage of horses and feed is a severe problem. From figures collected by the writer on about thirty medium-sized Ohio farms, it appears that 750 cubic feet of barn room are required per work horse, not counting storage space, alleys, etc. Figuring on equal weights of oats and shelled corn, the 5213 pounds of grain

for each horse would require 45 cubic feet of solid granary space. His 7073 pounds of hay, which would require 600 cubic feet to the ton when first put in, would occupy 2122 cubic feet. Adding 10 per cent. to each storage space to allow for waste, plus the space required for the animal itself, would give a total of 3244 feet for each animal and its feed. A barn for 15 horses would then contain 48,660 cubic feet, and at 3 cents per cubic foot enclosed would cost practically \$1460.

A 15-h.p. tractor is about 8 ft. wide, 10½ ft. high, and 16 ft. long. In order to make a building large enough to work in and store extra parts, one should figure on a garage of 14 x 20 feet on the ground and 11 feet to the square. It need not be so carefully planned as to ventilation and warmth as a barn. Being smaller, however, the building would cost more in pro-

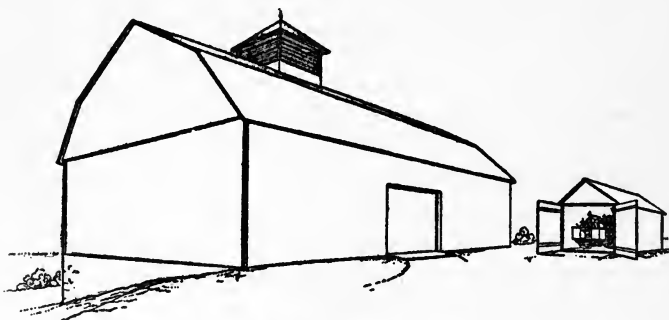

Housing of horses and tractor

portion, but even at 4 cents per cubic foot would cost less than \$150. Since fuel may be had at any time, the average man would not want to store a year's supply at once, but a 100-bbl. tank could be constructed under ground at far less cost than the difference between \$150 and \$1460. A fair-sized tank, which can be filled in idle seasons, is a great saver of time in the rush of mid-summer, and, since kerosene and distillate do not evaporate, the scheme is perfectly safe.

The labor-saving feature of the tractor is last, but by no means least. Two men will handle the tractor where five would be required for fifteen horses. One man can easily drive four, or even five horses, but Government statistics show that it requires about twenty-seven minutes every day throughout the year in chores for each work horse, hence one extra chore man's time would be well occupied, even with the horses idle. The saving of \$4.50 to \$6 per day on labor, to say nothing of the elimination of monotonous chores before daylight and after dark, makes powerful appeal to the farmer who must often buy machines that will not save money but will replace men who are not to be had.

We have said nothing about the many times in a year when only two horses are required rather than fifteen; of the vexing delays over the breakage of some trifling part; of the intelligence required to learn and operate successfully a new type of power as compared to one which the farmer knows almost by instinct; of the times when a tractor becomes stalled in the mud and cannot flounder out; and of other disadvantages. It is not logical to suppose that every tractor is perfect, and that the ownership and operation of one constitute a key to everlasting bliss. However, the advantages enumerated are real, and from the scattered cases of power plowing in the corn belt, are developing numerous communities devoted for the most part to traction farming.

## XXX

### POWER AND THE FOOD SUPPLY

**P**OWER controls our modern world, and since the dawn of history it has been the dominating influence in the transition from savagery to civilization.

The human race has always required power for three great essential purposes: tilling the soil to grow food and raw materials; changing the shape of materials to adapt them for use; and carrying men and products from place to place. In other words, power is required for agriculture, manufacturing and transportation.

The tiller of the soil in all ages has surpassed his contemporaries in the arts and commerce, in adapting animal power to human needs. He is thus the last to feel the need of a change to mechanical power, and so has escaped the final stage in the industrial revolution. But he is now about to complete the cycle. He has come to the point where the methods of the past will no longer suffice if he is to keep pace with the other factors in the world of industry.

Agriculture — the production of foodstuffs — cannot be concentrated physically. The farmer's workshop is broad, and his power needs as great at one corner as at another. The power plant for his work must be portable; if possible, self-propelling. Until the present generation nothing so met his requirements as the animal muscle. Man made his first step toward civilization when he took a crooked stick and began to till the soil, using the force of his own muscles. Later he conquered and enslaved to his purpose the power of the ox.



Upon cultivating the soil, he became master of the plants and shaped them to serve his purposes. With the plow the savage life of the hunter and the nomad life of the herder gave way to that settled agriculture that now yields our food supply and upon which rests our modern civilization.

Nature in her most extravagant moods has never brought civilization. In Columbus's time the entire continent supported fewer inhabitants than are now grouped in any one of a dozen American cities. With an abundance of wild game and fishes, the Indian suffered periodical famines, the severity of which was often modified only by the scanty supplies of maize raised by the squaws. The application of power to the soil and the civilizing influence of systematic work are the cardinal elements underlying continued national prosperity.

So long as a whole race must be occupied chiefly in providing itself with food and raiment, it has neither time nor desire for pursuits of a higher nature. To the substitution of brute power for man power the world owes the growth of cities, commerce, arts, and sciences. To steam it owes the gigantic development of industry and trade, but without the marvelous improvement which steam has wrought in farm machines, man, that most important link, could not have been spared from the soil. Even now three fourths of the population of the world is engaged in agriculture. The United States, leading the world in the use of power and machinery in rural industry, keeps one third her laborers and two fifths her capital employed in agricultural production.

Nowhere else has the influence of power upon the production of our food supply been felt as in America. In 1820, 97 per cent. of the entire population lived on farms, using hand labor for nearly every conceivable need. As late as 1810 the surplus products raised by four families were scarcely sufficient to support one in town. Improvements in the crude farm tools and the growing use of animal power added materially to the productivity of the average farm family during the first half of

the century. By 1850 the percentage of rural population had decreased to 90, and the labor of three farm families sufficed to provide themselves and two others with food and raw materials for clothes.

According to the Twelfth Census Report, 1850 marked the close of that period in American agriculture when the only farm implements and machinery, other than the wagon, cart, and cotton gin, were those which might be called the implements of hand production. Then came the era of farm machinery, and production during the first half century was overshadowed. By 1900 two farm families were not only able to support three others by their excess products, but their exports to foreign countries enabled the nation to maintain an unheard-of balance of trade. Systematic and vigorous use of animal power and machines for opening up new lands, for better tillage of the old, and for more effective preparation of products for market, put the United States in a half century in the front rank of nations. America has taught the world to save human labor by the use of machinery and power on the farm.

The American farmer, consciously or unconsciously, has recognized the value of power. Despite the lessening percentage of men working on the farm, every census except that of 1870 has shown a larger percentage of increase in the number of farm horses and mules than in the total population of city and country combined. By the middle of the century the ox had been practically discarded in favor of the more rapid horse. By the end of another half century each farm laborer had doubled the weight of his products. Two and a half times as many men were producing five times as much gross return. Strangely enough, but logically, this increase parallels the increase in animal power. Over four times as many work animals were used in 1900 as in 1850, and no less authority than Dr. Thomas F. Hunt attributes to the modern work animal, as a result of intelligent breeding, 25 per cent. greater efficiency than to the average of sixty years ago.

Even before 1900, every possible human task had been shifted to a machine drawn by animals. McCormick and his reaper had made three horses do the work of forty men with sickles. More horses were necessary, larger horses and machines of greater capacity the natural evolution. While two 1000-pound horses were the average team in the Central states in 1870, three 1400 to 1500 pound horses are now employed, with an increase of over 100 per cent. in power under the direction of one man. Under the never-ceasing cry for power the manipulation of animals by a single driver quickly approached the feasible limit of four horses in the Central states, or six in the great wheat belt, and with the new century the farm stood awaiting the coming of mechanical power.

The last decade has been most remarkable in the coming of greater power to the farm. The number of farm horses and mules of all ages was 25,163,000 on January 1, 1900 — according to the United States Department of Agriculture — an increase of 61 per cent. over the estimate for January 1, 1900. The value of both horses and mules per head had more than doubled, notwithstanding the millions of potential horsepower sold upon the farm in mechanical motors. A few thousand automobiles were the entire output in 1900; now a single manufacturer estimates his annual sales to farmers at 800,000 horsepower. Probably 12,000 farm tractors with 700,000 horsepower will go this year to swell the total of mechanical power on the farm. The stationary internal-combustion engine, lifting the minor burdens from which the animal could not release the farm worker, is practically a thing of this decade. In the last four years the size of such engines has increased from an average of 4 to an average of 6 horsepower. Seventy-five thousand new engines this year will further relieve the drudgery of farm work. Stationary, steam, electric, wind, and water motors will easily swell the total of mechanical power on American farms to two million horsepower.

Mechanical power, even on the farm, is now enjoying a swifter increase, both actual and relative, than animal power.

Animal power and machinery added 85 per cent. to the producing efficiency of the average farm worker between 1870 and 1900. For every pound of products raised by the workman who worked unaided in 1830, six were raised in 1895 with the help of machines and animals. One man could produce as much barley in 1895 as twenty-three in 1830. Between 1880 and 1900, in seven states leading in cereal production, each laborer came to handle more than three acres for every two he had handled before. Here and in the entire North Central division, farms of over 10 acres increased over 50 per cent. in size during the two decades. In the South Atlantic states, where human labor has been less largely displaced by machinery, farms became 10 per cent. smaller.

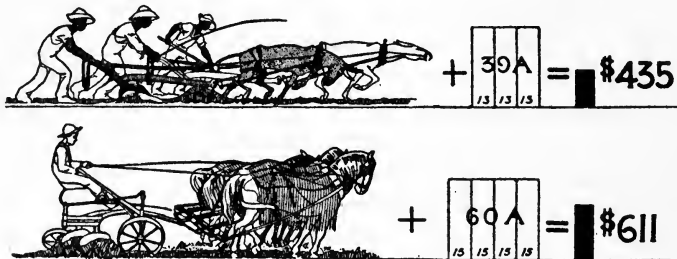

Effect of power on production

Fewer men, with more animals, not only handle greater areas, but receive greater rewards. Iowa, with nearly four horses to each farm hand in 1899, gave each man sixty acres of crops and an income of \$611, after paying interest on her investment. North Carolina and Alabama, with approximately two work animals to each three laborers, restricted each man to thirteen acres, and paid him less than one fourth as much for his work. Quaintance believes the average farmer to have been 42 per cent. better off financially in 1899 than in

1849, even considering the variation in the purchasing power of money. In the North Atlantic, North Central, and Western sections he was a trifle more than twice as well off, and in the two latter sections, where the greatest increase occurred in the introduction of farm machinery and farm power, he was three times as prosperous. Mulhall, in his "Dictionary of Statistics," issued in 1899, states that "In the United States nine million hands raised nearly half as much grain as sixty-six million in Europe." Germany owns one fifth as many horses as the United States for practically the same farm population. With the assistance of such a preponderance in power, the American farmer has been able to produce, albeit wastefully, from three to three and one half times as much as his competitor along the Rhine.

Changing the shape of materials, which we now call manufacturing, began with the grinding of grains and nuts into foodstuffs; the spinning and weaving of fibres into articles of dress; the shaping of stone, wood, and metals into implements and dwellings. It began with the human muscle. Even to-day the Russian peasants grind the grain by rubbing it between two stones. In other countries the circular millstone was developed and the animal harnessed. The work of spinning and weaving was done at first entirely by hand and foot. The later form of the loom was operated by animals from a treadmill. James Watt invented the steam engine in 1765 and since his time the industry of the world has centred in the steam-driven factory. More and more, mechanical power has been substituted for the human muscle, until to-day in manufacturing the master workman is but the intelligent onlooker, furnishing the machine with material and guiding its work.

The manufacturing industries of the United States even now probably have less than three fourths the power installation that is found on our farms, and not far from the same ratio of laborers. On the other hand, where the farm horse works

less than 1000 hours per year, the engine in the power plant works double that or more. Between 1890 and 1905 animal power on the farm increased a third, while mechanical power in factories increased 146 per cent. Laborers, too, flocked to the factories, and in the same time the excess in number of farm over factory workers fell from 75 to 35 per cent.

From transporting men and materials from place to place arises the third great need for power. Originally, this work was done by the human muscle; man walked, carrying a load on his back. Later, he learned to harness the animal, and down through the Middle Ages to the beginning of our century, animals drew the freight of the world over country roads in wagons. With the invention of Stephenson, who applied the power of steam in the field of transportation, came our modern railway net that to-day encircles the earth, and bears a steam-driven commerce that has linked the nations together. Just a century ago Fulton applied the power of steam to water transportation.

Artificial power has been applied to commercial transportation as to no other industry. Leaving out of consideration the electric railways, automobiles and all other forms of motor traction, and considering only the railways, we must try hard if we grasp the magnitude of the force that has pushed civilization from coast to coast and filled up every foot of promising area between. Five years ago the farm employed eight laborers to the railway's one, but the railway put into that one man's hand sixty horsepower, to two for the average farm hand. The railway forged ahead of the farm in power installed little more than a decade ago. Now it is adding power and men much faster than the farm, and enormously increasing its wealth and influence. Ten years ago, five horsepower worked to transport each passenger across the sea in ships. Now, on the *Lusitania*, already overtopped by a more powerful rival, thirty horsepower are throbbing in the engine room to bear him on with greater speed and comfort. Four times the poten-

tial power of our farm equipment is represented by our machinery of distribution, and double the annual use is made of it.

If George Washington were to come to earth now, and should visit the steel mills at Gary, or some busy machine-shop where huge plowing tractors are being made, he would be hopelessly bewildered. It is all beyond the philosophy of a man who lived one hundred years ago. There is hardly a process which he would understand. But if a contemporary of Moses, who was a good farmer, should come to earth and visit an ordinary American farm he would recognize practically every process. The industrial revolution, the steam engine, electricity, everything that goes to make up the steel age, have in fifty years created a greater difference in the production of the world, except in agriculture, than has been made since the days of Pharaoh. The corresponding revolution in agriculture has only just begun.

When Colonial America was in the age of homespun, the manufacture of the necessities of life kept workers on the farm. Mighty cities were impossible, since four families in the country could support but one in town by their surplus products. But when the steam engine entered the factory, capital and the most ambitious blood of the country were drawn to the cities. The farm worker, hard pressed by the demand for foodstuffs, sought larger areas, more power animals and better implements to meet the new necessity. Ox teams carried the pioneer far into the land of promise. He was one who must endure isolation, great hardships, and small returns. His inherited wisdom went for naught. He became an inventor, an experimentalist. Communication was slow, but that meant little, for principles of scientific agriculture were not yet formulated. Hard work prevailed where study was impossible and money for equipment wanting. The independent settler, working out his own salvation, disdained coöperative effort when real opportunity came. His development was one-sided, his farm organization small and unbusiness-like. Even to-day

the tiller of 25,000 profitable acres is hailed as captain of industry.

Yet the farmer has prospered. Our farms produce a million dollars an hour, and one rural family feeds two in the city. The farmer of to-day has wonderful agencies to make his work easy. Farm machinery has been marvelously perfected. Railroads simplify the exchange of products. Agricultural scientists are solving his problems, and the telephone, telegraph, and rural free delivery bring him daily news of the latest discovery. The automobile, with its tremendous influence for good roads, banishes isolation and puts him into quick touch with markets. Modern conveniences in the home remove a thousand hardships. Nearby towns, with banks, elevators, and stores, handle his products and supply him with necessities which formerly depended on his own ingenuity and skill.

With all this assistance, the American farmer is falling behind in his work. Four prosperous decades have brought to our shores hordes of European peasants, have increased our population one and a third times and each mouth takes a fourth more wheat than before. In the past America has been called upon to feed not only her own natural increase in population and the outpouring of the nations of Europe, but millions of those who remained behind. Faster, surer methods than had ever before prevailed were necessary. Intensive cultivation deferred to extensive production, and the task was accomplished. The United States now faces a different problem — that of feeding a swiftly increasing population with a slowly increasing acreage. Intensive methods and more power must be applied. Teachings of agricultural scientists must be universally heeded. Better seed, deeper plowing, more thorough tillage, must lay the foundation for greater yields from each acre. Waste places must be reclaimed, our whole productive area developed and occupied. But our present needs are enormous, increasing more swiftly than these ideals can be realized. Greater areas must be brought immediately into productiveness, must main-



tain maximum yields indefinitely, if production is to keep pace with demand.

The lack of power for plowing is the greatest obstacle to the extension of our wheat raising area into virgin fields and the realization of greater returns from our older lands. This work of plowing with which man began his systematic labor remains to-day his severest toil. For man, as well as animals on the farm, the dusty monotonous work of plowing is the hardest drudgery. Think of the power required to pull a plow only the distance across the room, and then of the eight and one fourth miles of furrow travel in every acre of land. To plow a square mile with a twelve-inch plow, one man and two or three horses must each walk 5280 miles, the team constantly exerting power enough to move ten tons over a city street. It is easier, and the distance less, to walk around the earth at the equator than to follow such a plow turning a tract of five square miles. To plow three townships the plowman must walk as far as from the earth to the moon and back again, and sixty thousand miles farther. To equal our annual tale of plowing, seventeen to twenty plowmen must make a round trip to the sun. Pulling a plow three and one half inches deep through prairie sod is equivalent to lifting a constant load of seven hundredweight. The plowmen in the United States turn over each year two billion tons of earth. They exert power enough to lift the visible portion of Manhattan to one and a half times the height of the Eiffel Tower, and the cost of their work places an annual tax of \$25 on every family in this broad land of ours.

Plowing is the greatest single item of power consumption on the farm. To plow an acre of old land, the farm horse works from eight to fifteen hours under a greater strain than in any other task. One fifth his total hours of work and one third his yearly expenditure of power in the Corn Belt are at the plow. In small grain sections one fourth his hours and one half his power are expended in turning the soil. Plowing

consumes 43 per cent. of the power spent on the corn crop up to the moment of harvest, and 60 per cent. of the power required to place wheat on the ground in bundles ready for shocking. Even this expenditure of power is not great enough. A summary of opinions from eight experiment stations places the average depth of plowing for corn *by the best farmers* at from four and three quarters to five and one quarter inches. *Almost without exception it is recommended that from one to five inches be added to the depth to secure maximum yields!*

Over twenty-five millions of horses and mules are now kept on farms to four millions in cities. Probably fifteen millions are ordinarily used for farm work. The remainder comprise the colts and breeding stock required to keep up the supply for town and country, the driving horses and the idlers. In the plowing season the young and old, the able and the infirm, must bend to the collar for four weeks of muscle-straining drudgery—drudgery that so reduces the animals in weight and vitality that even the long period of light work and idleness preceding the harvest scarce enables them to recover their condition. And yet, with all this toil there comes from the West the plea for deeper plowing to establish a moisture reservoir; from the corn belt and the South for a deeper and more mellow feeding area for plant roots. To supply these conditions requires power—power that cannot be economically supplied by animals because of the high cost of maintenance and the lack of work during all but a few weeks each year. To double the depth of plowing means keeping nearly seven horses for the twenty to thirty days of plowing to each one required at any other time save the brief harvest.

In the easiest plowing, five or six horsepower-hours are consumed in plowing an acre. Ten, twenty, even forty, horsepower-hours must be applied to more difficult soils for the same result. In addition, the mere effort of a man and two horses in walking over the ground consumes seven million foot-pounds of energy to the acre on the best of footing. Ten horsepower-

hours consumed in forward progression and useful work is a *minimum* figure for the acre, three billion for the nation. Only 40 per cent. of the area of continental United States will be improved in 1940, according to Mark A. Carleton, cerealist of the United States Department of Agriculture. Deeper plowing must be universal — twenty horsepower-hours to the acre must be the rule instead of the exception — fifteen billion horsepower-hours the amount of power spent annually in turning the soil if the nation is to be fed. Twenty-three million work horses must be used for one thousand hours per year, ninety to one hundred and fifteen millions for the hours now available for plowing, if the work is to be done by animal power.

For each work horse and the surplus needed to keep up the supply, five or more acres of harvested crops are required for support. Greater animal power applied to each acre will increase the yield, but not so fast as it will multiply the number of animals required to produce that power within the brief plowing season. We can even conceive that with the highest possible yield secured by the application of animal power to the plow, the area required to maintain the animals will leave little or nothing for the production of human food. The percentage of the total area devoted to power production must decrease, rather than increase. More acres must be added to our farm area, more bushels garnered from every acre, and less fed to unprofitable animals if we are to maintain our place among the prosperous nations of the world.

The animal muscle has reached its present perfection only after ages of natural selection, extending back to the very dawn of life. Centuries of breeding and selection by man have advanced the animal in size, but otherwise only to a slight degree in efficiency. Further perfection must be slow, individual rather than racial. Many mechanical motors already surpass the horse in commercial efficiency — some in the ability to convert latent chemical energy into useful work.

The animal must have frequent rest while at work. Under average farm conditions it is idle eight hours in nine, yet it must be kept warm and sheltered, must be fed and watered three times a day whether in use or not. It deteriorates rapidly in use or idleness, and is subject to premature death. Two per cent. of all horses die of disease each year, and their working life is less than ten thousand hours of actual service.

The new farm power, the mechanical tractor, does not age nor deteriorate when idle, and requires neither fuel nor attendance when not at work. It solves the peak loads in agriculture — seed time and harvest time. The time spent annually in caring for one horse will keep it in perfect working condition. A mass of tireless but obedient steel, it will endure heavy work twenty four hours instead of six, and outlive the average work animal in hours of service. It can be sheltered with a year's fuel supply in a tenth the space required by horses of equal power and their feed. It concentrates in one man's hands the power of twenty horses, the endurance of a hundred, and adds many fold to the acres he can cultivate. For the present it consumes nothing from acres which might produce food for mankind.

At the close of the nineteenth century there remained practically no field which the manufacturer and inventor had not touched upon in the effort to conserve human labor. Mechanical power and invention had largely fulfilled their immediate promise to the industries of making and carrying, and with the twentieth century dawned the last great epoch in the transition from hand to machine power in human enterprise. Agriculture, the greatest of all industries, awoke fully to the necessity for greater power — mechanical power. The duty of agriculture is to supply food for the people, raw material for manufactures, and products for trade and transportation. With the introduction of machinery and animal power, this task has been accomplished with relatively fewer and fewer workmen. The application of mechanical power, which is

now the most promising development in agriculture, will permit of a further reduction in the numbers required to supply food and other materials, and force a greater return from the soil to keep pace with the constant increase in population. America has taught the world the conservation of human labor by power machinery in manufactures and distribution; she must teach herself the use of power machinery in agriculture or keep more and more of her workmen from their places in the struggle for national commercial supremacy.

“Every invention which enables mechanical power to supplant animal power is a distinct advantage to society,” says Doctor Hunt. It is not to be supposed that mechanical power will entirely supplant the animal, even as brute power has never displaced the human muscle. In the history of the human race, man’s activities have ever increased with his opportunities. The introduction of mechanical power on the farm will augment man’s resources rather than change entirely his sources of motive power. The influence of power on manufactures and transportation is an indication of what may be expected in agriculture. Not only will production be increased and systematized but farm organization will take on in greater degree the aspect of the factory. Efficient production demands large units. Farms which can be operated by mechanical power must continue to grow larger and more centrally controlled. Ownership and management will inevitably approach more and more that of the centralized industrial corporation, unless the individuality of the farmer can be maintained by effective coöperation.

Ten years ago, at the University of Oxford, a lecturer on political economy laid it down as axiomatic that science and invention, the division of labor, the law of diminishing returns, could do little to save human labor on the farm; that the conditions of its toil were nearly unalterable, its processes predestined to be slow. Yet these few years have seen immense advance, and to-day no forecast can predict the progress of

the future, for man is clearly shaking off the heavier shackles of manual toil. Pipe and tabor no longer lead the procession of harvest home, but drudgery goes as well as romance, and a business air sets the thresher to factory pace. A manufacturer's catalogue says "To-day a new world has opened for the farmer. To the aid of nature he has called the forces of science. His factory under blue sky is as busy, and the wheels hum as merrily as under any city-factory roof. *Power* — and the most economical, pliant, and efficient of all power — is at last his."

## THE CHOICE OF POWER

**I**N SELECTING a tractor for plowing, there are countless factors to be taken into consideration. In choosing a particular motor out of a general class, its adaptability to the most pressing work must be considered. However, before coming to that point, the broader question of the type of power must be settled. It would be next to impossible here to compare intelligently the multitude of breeds and types, but a brief comparison of the animal, steam and gas motors should be reviewed before making the final selection. In purchasing a motor for plowing, one should satisfy himself as to the investment; the efficiency in various particulars; the question of fuel supply; the cost of maintenance during work and idleness; the attendance required; the concentration of power; the speed; effect upon the soil; the range of usefulness; the endurance and the many phases of each and every one of these essential considerations.

The horse is the product of thousands of years of natural selection and of three centuries of careful breeding. The best examples of his kind have seen but little improvement during the century and a half of steam engine history. The steam tractor is old and the gas tractor new. The traction mechanism of both is in about the same state of perfection, but in a quarter of a century of real development the gas engine has become thermally much more efficient than the steam engine. We may look for more rapid progress in the gas engine than in the steam engine or the horse, but as an average of all represen-

tatives of each class, the two latter have the advantage of reliability gained in many more years of field service.

One horse cares for twenty-five acres of crops. To his value of \$150 to \$250 must be added the value of his harness, and the breeding stock necessary to maintain the supply. For every horse at work the farmer has an investment of \$250 to \$300, or more than \$10 per acre. A steam engine complete with all equipment, except plows, will cost about the same as a gas tractor of equal tractive horsepower with its less extensive accessories. For each actual drawbar horsepower, either type of engine and its equipment will cost from \$90 to \$100 in the sizes commonly used for plowing. For the ordinary size, the farmer's investment per acre is thus about half what is required with horses. The smaller the tractor the greater the cost per horsepower, hence in the smallest sizes the advantage in investment is wiped out.

These figures take no account of the fact that the farmer's horses are part of a factory equipment for producing power animals, hence the investment in tractor factories should possibly be considered also. On the other hand, the farmer who does not raise his horses must pay a higher price than is assumed above. In the West a sound, well-trained horse, capable of developing a full mechanical horsepower in plowing, brings from \$200 to \$300. Western Canada in 1910 imported \$10,000,000 worth of horses at the rate of \$300 each, and pressed thousands of oxen into service at the plow for want of horse flesh at any price. The mechanical motor can be more quickly supplied to meet the needs of the season, as factories working over-time can maintain an enormous output, while a steady demand in the horse market waits four years for a response.

The plow equipment required for each acre tilled by the horse, is small. Three horses require a sulky plow, costing \$40 and plowing seventy-five acres per year, or less than 50 cents an acre. A large steam engine will require an investment of



approximately \$1.00 per acre plowed annually. The gas tractor, pulling a lesser number of plows, will require as much as the steam engine, or perhaps a trifle more, as the smaller sizes of plow cost more in proportion.

While at work the horse requires the greatest amount of labor, the steam engine next and the gas tractor the least. However, the horse while at work requires no adjustment, no other attention than driving, and his food and water may be taken at any convenient time and place. The tractor's fuel and water is most cheaply brought to it, while the horse economically goes after his. During idleness the horse requires daily care, keeping men on the farm when no other work requires their attention. He must be kept constantly warm and sheltered, fed, watered, and protected from injury and disease, while the tractor needs simply cleaning and oiling when set away, and thorough overhauling before again being put in commission.

One man may drive five horses, and in some cases even twenty-five, but only in certain operations. Three to six men and from two to six horses keep a steam engine at work with the power of forty horses, one man controlling the power of from six to twelve horses. With the gas tractor, one man may control the equivalent of from twenty to thirty horses, but the plowman's time must also be considered, since with the horse outfit the driver is both engineer and plowman.

The average farmer knows the horse by instinct. A great many operators know the steam engine well enough for practical purposes. Five years ago the gas engine was a mystery to the average farmer. Now the stationary gas engine and the automobile have educated him to the point where he regards the gas engine as the next thing to the horse in simplicity. Ordinary farm labor will more quickly grasp and operate the gas tractor than the steam tractor, although much harm was done in the early days of the gas tractor by unwarranted

claims as to the class of labor which can safely be intrusted with it.

Of the three classes, the horse develops continuously the least power in proportion to his weight, and his bulk is distributed over a wider ground area, making his use in large units cumbersome. For each horse in the field, 20 to 25 square feet must be allowed, while in a tractor the power of sixty horses may be concentrated in a single unit, requiring less than 5 square feet for each horsepower. In the units where horses and tractors compete, the engine is much more easily manipulated. While the bulk of the tractor is concentrated, the actual supporting surface on the ground is sufficient to reduce the pressure per unit to, or only slightly above, the pressure of the horse's foot.

The commercial success of any type of power depends to considerable extent on its fuel economy. The steam engine at the present time uses a wide range of fuels, taking them just as they come. Its sources of supply are wide, and its most convenient fuel, coal, is by no means exhausted. The gas engine, as used on tractors, requires fuel that has been made fit for use by a refining process, hence the sources of supply are more easily controlled by individuals. The steam engine of the present and the alcohol engine of the future will make use of all the waste materials about the farm. The horse utilizes no waste material, except certain unimproved pastures, and for the production of power requires a large part of the most valuable products of the farm. His fuel, however may be raised by every farmer every year, and on many sections of Western prairie, a great portion of his maintenance still comes from wild hay, which can be stored during slack seasons at the mere cost of gathering.

In utilizing fuel, the average farm horse in any year probably converts less than 2 per cent. of heat supplied into energy delivered. The steam engine in plowing has only the same ratio or a trifle more, while the gas tractor at the same time

converts from 10 to 15 per cent. of the heat energy in its fuel into useful work. In stationary work the power of the horse is decreased in transmission, while both types of tractor save the enormous loss due to the propulsion of their own weight, the steam engine delivering 4 to 6 per cent. and the gas engine from 20 to 25 per cent. of its fuel energy to the driving belt.

The local cost and quality of fuels will vary widely, but the following table, showing the heat units which could be bought wholesale for \$1.00 under northern Indiana conditions, gives a fair idea of the relative cost of energy in various fuels:

ONE DOLLAR'S WORTH OF HEAT UNITS IN VARIOUS FUELS

KIND OF FUEL	COST OF FUEL	B.T.U. CONTAINED	B.T.U. BOUGHT FOR \$1.00
Bituminous coal	\$3.00 per ton	13000 per lb.	8,670,000
Hard wood (dry)	8.00 " cord	8500 " "	4,250,000
Kerosene 44°	.32 " gallon	20000 " "	4,187,500
Anthracite coal	7.00 " ton	14000 " "	4,000,000
Hay	10.00 " "	8100 " "	1,620,000
Gasoline 64°	.10 " gallon	20000 " "	1,204,000
Oats	.30 " bushel	8400 " "	896,000
Corn	.50 " "	8000 " "	896,000
Illuminating gas	1.20 " 1000 cu. ft.	550 " cu. ft.	460,000
Alcohol, 90 per cent.	.45 " gallon	11500 " lb.	174,500

Low-priced fuel is not necessarily cheap fuel, as its value depends largely upon the heat units it contains. Moreover, some cheap fuels are as cheap as they are, largely because scarcity has led to the general abandonment of their use. Cordwood, for instance, stands second on the list in point of cheap heat units, yet if any considerable dependence were placed upon its use for power, its price would be prohibitive. Some of the lightest petroleum products are in the same category, and, as we have seen, others are tending to become scarce. At the prevailing prices it would seem that even the more abundant petroleum fuels are almost prohibitive in cost for a given quantity of heat units. However, even heat units are not a reliable indication of the value of a fuel for

power production. We must remember that coal and wood are used only in steam engines, which waste far more energy than the motors burning gasoline and kerosene. The animal motor on the farm, converting into power for plowing a low percentage of the energy it receives, places the products of the field far down the list as power producers.

The engine will outlast the horse, if properly cared for. Repairs cost no more than shoeing and veterinary attendance. The storage space for the animal and its food must be enormously greater than that for the tractor. In the city, the forty-horsepower auto seems lost in a corner of the barn which formerly housed a half dozen horses, their feed and equipment, and the modern garage in the back yard seems like a playhouse. On the farm the shed for the tractor is insignificant compared with the horse barn and needs far less care in its construction. A ton of hay occupies from 400 to 600 cubic feet of space; a ton of coal from 35 to 40 cubic feet; a ton of gasoline about 47 cubic feet; and a ton of kerosene about 40 cubic feet. Given the space required to store the work horse's feed for an hour, one would figure on about 10 per cent. as much per tractive horsepower hour for a steam engine, 2.5 per cent. for the gasoline engine, and 2.3 per cent. for the kerosene engine.

One horse plows an acre per day. The steam plowing engine plows thirty acres in the daytime, and as much more at night, if required. The gas tractor, stopping less often for supplies, may compare favorably with the larger steam tractor, since it will travel more miles in a day for the same geared speed. The horse must cease work for rest while either tractor works on. The gas tractor carries fuel and water for the day. It can go farther from the base of supplies than the horse, which must have food and drink every eight miles of plowing, or the steam tractor, which runs short of water in two.

Endurance is the horse's weakest point, and flexibility his strongest. By coupling from one to ten large horses together in teams of different size, one has economical motors of from one

to ten horsepower. In an emergency each horse may double or triple his power, and sustain it for some time without injury. The steam engine through the expansive force of steam, is more flexible than the gas tractor and the wide range in point of cutoff gives it admirable overload capacity. In the gas engine the maximum power is developed at the moment of explosion. A considerable momentum, sufficient to carry the tractor over ordinary emergencies, is stored in the flywheel. However, if a sudden obstacle overloads the gas tractor while its speed is reduced, it promptly stops working. In that respect it is perhaps the most advanced of the three, since it tolerates less abuse on the part of the operator.

As conditions are found on the farm, the horse has probably the widest range of usefulness. His economy in small power units, his great overload capacity, and the fact that he is ordinarily ready at an instant's notice, make him by far the most convenient power for widely diversified work. For operations requiring stationary power or great tractive power, he is seriously handicapped, and yields to both types of tractor. The steam engine is economical of labor only in the largest units, hence is adapted more particularly for enormous volumes of work in the field. Its great weight adapts it to plowing new land and heavy hauling on good roads, rather than for lighter work, though the lack of suitable bridges reduces its usefulness in the latter particular. The gas tractor is economical of fuel and labor in both large and small units. It is generally lighter than the steam tractor for the same tractive effort and is made in more widely divergent forms. It is cleaner and more convenient to handle, is much quicker to start, and undoubtedly stands second to the animal in general utility.

In so far as it is possible to generalize in ranking the three types of power for plowing purposes on the foregoing essentials, it has been done in the following table. Only the standard representatives of each type are, of course, considered. Aside from the factors, involved in selecting a motor for plow-

ing, several are included which have to do with its usefulness for general power purposes. To the many exceptions which may be taken, the only answer is that the ranking has not been undertaken except after exhaustive study of the adaptability of the standard general-purpose tractors to plowing in a wide sweep of territory, presenting an extreme range of farm conditions, in which naturally, many cases can be cited to which few of these assignments will apply.

RELATIVE ADAPTABILITY OF COMMON MOTORS FOR PLOWING

ESSENTIAL PHASES OF ADAPTABILITY	FARM HORSE	STEAM TRACTOR	GAS TRACTOR
Flexibility in power	1	2	3
Reliability	1	2	3
Range of usefulness	1	3	2
Necessity for adjustment	1	2	2
Ease of repair	3	1	1
Endurance in hours of work per day	3	1	1
Period of work without renewing supplies	2	3	1
Concentration of power in ground area	3	1	2
Investment in power per acre tilled	3	1	1
Investment in plows per acre tilled	1	2	3
Storage space per tractive h.p. of motor	3	1	2
Storage space for fuel per tractive h.p.-hr.	3	2	1
Quality of shelter required	3	1	1
Cost of maintenance in idleness	3	1	1
Cost of operation in small units	1	3	2
Cost of operation in medium to large units	2	2	1
Cost of operation in very large units	3	1	1
Skill required in operation	1	3	2
Amount of labor in operation	3	2	1
Frequency of attention in idleness	3	1	1
Weight of fuel per unit of work	3	2	1
Weight of water per unit of work	2	3	1
Variety of fuels utilized	2	1	3
Distribution of common fuels	1	2	3
Convenience in handling of fuel	3	2	1
Cost of energy in fuels	3	1	2
Thermal efficiency in stationary work	3	2	1
Thermal efficiency in plowing	2	3	1
Tractive power in relation to weight	3	2	1
Tractive power in relation to stationary power	1	3	2
Stationary power in relation to weight	3	1	2
Mechanical efficiency	-	1	2
Pressure exerted upon soil	1	3	2
Promise of future improvement	3	2	1

## RECAPITULATION

TYPE OF POWER	1ST OR TIED	2D OR TIED	3D OR TIED
Farm Horse	10	5	18
Steam Tractor	13	13	8
Gas Tractor	18	11	5

A thousand and one variable factors operate to shift the advantage in economy from one type of power to another. A thousand factors other than cost make one power the most adaptable to a given problem. Conditions are not exactly the same on any two farms and each farmer must decide for himself the type of power best adapted to his use. After that he should attempt to secure by a single purchase a motor that is simple, durable, reliable, and efficient — adaptable to its work, its working conditions, the intelligence of its operator, and the fuel which he is able to provide most easily and at the lowest cost.

## XXXII

### THE FUTURE OF THE TRACTION ENGINE

**T**HE field that is now ripe for the introduction of tractors on American farms alone is enormous, without considering future and foreign opportunities. The tractor is best adapted, as we have seen, to the raising of cereals. Thirty-five per cent. of the horses and mules of the United States are found in ten cereal-producing states where tractors are already used in large numbers. In 1909, Minnesota, the two Dakotas, Montana, Nebraska, Kansas, Colorado, Oklahoma, Texas, and California had 8,766,000 horses and mules of all ages, worth \$859,444,000, according to the latest Year Book of the Department of Agriculture. This is over five times our total annual output of tractors and farm machinery for both domestic and export trade. Many farmers in these states are replacing four horses out of five with gas tractors. Let the average man replace but one in five, and there is sale for over 60,000 tractors at \$2500 to \$3000 each. To pay cash for them would take less than one seventh of the crop values produced in these states in the year mentioned.

The tractor will eventually occupy much of this field. It already saves enormously in the cost of production and marketing. In the future we may expect to see great improvement in performance as operators become more and more skilled. We may look for cheaper costs of manufacture when machines are standardized, when designing has been reduced to a written science and when the experimental cost has been



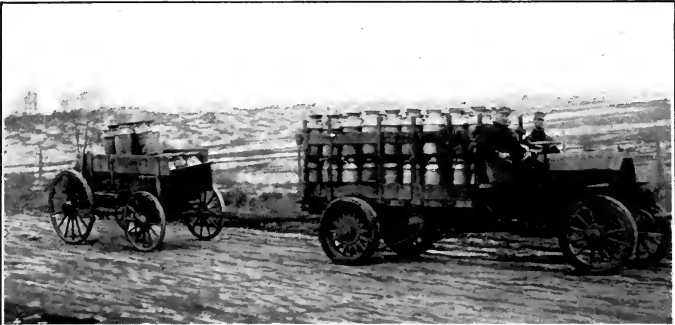

**THE VARIOUS USES OF THE TRACTION ENGINE**

- A swift trip to the creamery
- Pulling harvesters and a lift plow
- Reclaiming waste areas



distributed among many machines of the standard types. The tractor is at the dawn, rather than the twilight, of its development.

The rapidly increasing sale of tractors is due quite largely to the many new uses to which they have been put. The traction engine has developed from a monstrous toy into a powerful and efficient servant. Its influence on the plow and production has already been discussed. With the plow and the thresher it has revolutionized the grain-raising industry, made possible the settling of the Great American Desert, cheapened the cost, and tremendously improved the quality, of our daily bread. The same engines that solve the dry-farming problem may have to cross rough fields with the threshing separator, ford streams where bridges are unsafe or have not yet been built, and even climb sizable mountains. It is all in the day's work, and has no terrors for the experienced tractioneer. Perhaps the house or granary needs moving, or maybe it is a load of lumber from the railway. Possibly the road has to be built first, or perhaps the railway, and after sawing timber for bridges and ties, the tractor must grade the embankment all the way from farm to the flour mill.

Off the farm the tractor has made possible the utilization of many out-of-the-way patches of timber, and numerous small deposits of stone have been turned by its aid into crushed surfacing material for the highway. It is rapidly displacing the horse in building and maintaining country roads. It digs irrigation canals and fills drainage ditches. Contractors are employing it more and more in the arts of peace, and nations are increasing its use for the business of war. It has hauled machinery to the mines, raised the ore and carried it to the railroad or smelter. It has brought enormous logs out of the forest where big teams of horses could not manœuvre. It hauls the drill and the well casing to the oil field and helps produce its own fuel. Even that most marvelously organized thing, the modern circus, is playing traitor to the elephant and shifting

its heavy trucks with the traction engine, which also runs a dynamo for lighting the evening show.

What the tractor has done in the past is but an inkling of what it may do to aid humanity in the future. However, its benefits will not be universally enjoyed until men universally realize its usefulness and contribute more generously than in the past to making conditions favorable for its work. Its future is by no means entirely in the hands of its manufacturer, nor yet of the farmer alone.

The future of the tractor depends a great deal on the education of the people. The average farmer is familiar with the horse from childhood. His son is learning the art of running an engine, and colleges are educating a few in both the art and the science. This phase of agricultural college work should be richly endowed, since it is also giving students a broad grasp of the profession of agricultural engineering. This will fit them for directing the organization of farms and rural communities on a more efficient basis, and the greatest efficiency in the future will be realized by the use of all forms of mechanical power.

The farm, after all, is really an engineering proposition. After the chemist, the botanist, and the fertility expert have determined how a crop shall be raised, the actual raising of it is a mechanical problem. The storing of the crop, its transportation, its protection from the elements and living enemies, all require the exercise of engineering knowledge. There is a need for a great national bureau in the Department of Agriculture to bring the engineering problems of the farmer to a focus, where they may be solved by the men best qualified. The farmer often fails to analyze the need for some machine until it appears on the market. The manufacturer is often handicapped in his investigation of the field for new machinery by his lack of training in the problems of the farm. He is forced to hesitate in developing new types to meet apparent needs by the necessity of securing a commercial success. He is

thus apt to wait until forced into new departures. He needs the broader outlook which could be secured from a central organization having the viewpoint of the manufacturer, the farmer, and the general public, all in one. The nations of Europe, even Russia, are years ahead of us in this respect.

More suitable machinery is needed for making use of the tractor's power, and to some extent the tractor's success is dependent on the progressiveness of manufacturers in other lines. The case is somewhat parallel to that of the edge-drop corn planter, which was not a brilliant success until after agricultural colleges had induced farmers to grade their seed corn. Then the new style planter proved to be far ahead of the old, even in the latter's best days.

We already have very efficient engine gang plows, but in the main we are using the harrows, drills, and harvesters developed for use with horses. Recently an experimental grain drill of greater width and strength has been offered for engine power, while other companies have just put forward large double-disk harrows, which are compact and thorough in their work. Another company makes a very efficient device for hitching a number of binders together, adding many days each year to the use of the engine. Large, heavy wagons, designed to follow the track of the engine around any corner, add to the possible length of the wagon train, and are so devised that they may be drawn from either end to adapt them for use in close quarters and save time in turning. As a rule, however, the farmer must use some machine suited to animal power, and not strong enough to withstand the strain when the power of from twenty to thirty animals is exerted against a single point. No engineer has as yet earned lasting gratitude by devising an easily manufactured hitch, whereby these various implements can be conveniently attached in numbers sufficient to utilize the full power of the engine. Even the plowmaker could add to the success of the small tractor by devising a simple means for enabling the engine driver to handle the plows easily without

leaving his platform. A simple, durable and efficient power-lift plow, using some other medium than steam, would assist in the solution of this problem.

But the tractor has still greater opportunities open to it. Had the steam tractor become even fairly well perfected in the early days of the nineteenth century, before Stephenson brought forth his railway, the latter might easily have been delayed for several generations. In its place we might have now a nation closely knit together by a system of excellent roads, upon which our freight and passenger traffic would proceed. But empire builders have pushed smooth steel roads over easy grades into all corners of the continent, and brought the ton-mile cost of freight on heavily patronized lines to three eighths of a cent. On our crude rural highways, horses haul farm products at twenty-three cents per ton-mile and the best tractors at ten cents, competing with the locomotive only in the ability to traverse the byways and penetrate the fields left vacant by the network of railway steel.

Brandeis startled the world by declaring that he could save the railroads of the country \$300,000,000 a year, simply by improving their efficiency. What then might the nation be saved if possible reductions were made in the cost of transporting farm products? Mechanical power has revolutionized transportation on railways and steamships, but masters of the art have neglected the opportunity to apply it to a business which the United States Office of Public Roads estimates at a half billion dollars yearly. The opportunity of saving three fourths of this cost by the introduction of mechanical power is as startling as its neglect is deplorable.

Why has the traction engine not already saved the greater part of this preventable waste? The answer is, that it is more sadly handicapped than the horse by the conditions that cause the waste — to wit, bad road surfaces and steep grades. It is here, much more than in plowing, that the wonderful flexibility of the horse finds its greatest usefulness. The gas

tractor, with its capacity for making an average round trip from farm to railway without rest of supplies, is the worst handicapped of all. Taking advantage of nature's gift to the animal, we have built our highway system upon it, rather on the basis of efficiency. As a result of the system, it cost in 1906, when ocean rates were unusually high, 1.6 cents, or 40 per cent. more to haul a bushel of wheat 9.4 miles from the farm to the railway station, than to haul the same bushel 3100 miles from New York to Liverpool.

In a report to the Country Life Commission, from which these figures were taken, the Office of Public Roads states that the cost of hauling with horses over our wagon roads is not less than 23 cents per ton-mile, and probably 2 or 3 cents higher. On the good roads of France, England, and Germany, transportation with horses costs from 7 or 8 cents to 13 cents, or an average of 10 cents per ton-mile. With universally good roads the annual saving in our cost of hauling the products of farms and forests to the railway would be a quarter of a billion dollars on the basis of animal traction alone. Every argument in favor of good roads for horse haulage is doubled in force when we think of hauling with an engine. Better conditions for the use of mechanical power reduce the cost in geometrical ratio, until under the best conditions, as illustrated by the railroads, the cost is a trifling percentage of the tax now imposed by animals and bad roads.

The steam tractor is not quite so badly handicapped by present conditions as the gas tractor. In England it is used extensively for heavy transportation over public highways. With some changes in the design of tractor it might be possible to effect an enormous saving in America without such a sweeping improvement of roads as would make the gas tractor most efficient. However, significant of what can be done by the gas engine on short hauls with frequent stops is the growing tendency of steam roads to use comfortable gas-driven cars for local and suburban service. In the United States, more-

over, the gas tractor has a better opportunity than in England, owing to the lower price of suitable fuel.

The selling price of farm products is rarely under the farmer's control. His profits are represented by the difference between the selling price and the cost of production and transportation to market. As the tractor cuts the cost of production, so it adds to his profits. As it further cuts the cost of road transportation, it adds greater profits without increasing the cost to the consumer, and by increasing agricultural prosperity, increases the welfare of the country, which is dependent upon that of the farmer. The cheap transportation secured by the use of better roads, which in turn favors the increased use of mechanical power, will enable the extension of the zone around each marketing centre in which certain bulky and perishable products can profitably be raised. It will increase land values. It will equalize supply and demand, since crops can be stored at the lowest cost on the farm and moved at any time during the year. It will equalize the traffic upon railroads, and make Brandeis's saving easier. It will increase rural population, encourage the attendance of children at school, extend the usefulness of motor vehicles for passenger transportation, and develop an attractive social side to farm life.

What do we need in the way of road improvement? In a nutshell, we need to eliminate grades and establish better road surfaces. The loss in traction efficiency due to poor surface has been shown elsewhere, and that due to grades is perhaps even greater. The power required to lift the prime mover itself up a certain grade is constant, regardless of surface, and the better the road surface the more rapidly will each percentage of grade cut down the proportion of the tractor's total power which it can exert in pulling the load. To secure ideal conditions, we must have state-wide road laws and standards of quality in construction. Whether the road shall be built by state or national aid, or by county funds alone, is a matter of detail. The main point is, that the administration of these



funds must be placed in more intelligent hands than at present. In the majority of states able highway engineers are prepared to investigate, advise and assist, and there their authority ceases. They should be empowered to put into practice the results of their experience and training. They should be assisted by competent highway supervisors, and road district units should be made much larger than at present, in order to afford and command the service of trained experts.

In spite of the loyal assistance which the traction engine is now giving in building improved roads, the average legislator is unable to see in it anything but an ugly machine which scares horses, sets fire to property, breaks down bridges, and destroys road surfaces. As a matter of fact, manufacturers everywhere are willing to provide reasonable facilities for changing grouters on plowing engines once they are proved destructive. It is firmly established, however, that the pneumatic tire of the modern automobile is far more injurious to good roads than the heaviest steam tractor's drive-wheels. In fact, the state highway engineer of Wisconsin recommends the use of the traction engine in building and maintaining roads on account of the power which it makes available for doing good work with a grader, and because of the compacting effect of the wheels.

Much of the opposition to the tractor comes from a well-organized purpose on the part of selfish interests to keep vehicles off the public road that will make it necessary to provide better and safer bridges. The control of public bridges is generally in the hands of the county supervisors, who are not chosen with reference to their engineering ability. In consequence, they are at the mercy of bridge-building concerns which make enormous profits out of the construction of flimsy bridges at excessive cost to the public. In crossing these bridges the tractioneer takes his life in his hands, and often is heavily liable as well for damage to the structure. The average state highway commission is powerless to do more than to recommend praiseworthy laws and specifications. In the face of a powerful

lobby their recommendations count for little in the framing of intelligent and just legislation.

Tractor manufacturers and the farming public must soon insist upon the right of the traction engine to its place on the public highways. Its abolishment would set the country back fifty years in its methods of wheat production, and cause untold ruin and actual suffering through the shortage of food-stuffs. Why, then, should the owner of such an engine be regarded in some states as a criminal in the eyes of the law while in pursuit of his daily occupation? Why should the farm tractor, which has created a new era in agriculture, and revolutionized the methods of doing countless tasks both on and off the farm, be discriminated against as a public nuisance? Here are questions for engine manufacturers, for farmers, engineers, and the intelligent business public to weigh carefully and act upon.

The farm tractor solves the problem of our daily bread, and makes possible the utilization of our whole wheat-producing area. Its use is rapidly extending into the regions of smaller farms and more intensive farming. It holds out the promise of greater improvement and greater benefit to humanity in the future than the mechanical power applied to the great industries which have grown so enormously by its use. Until now the use of the tractor has been so limited, and the interests concerned in its manufacture and use so dwarfed by great industrial corporations, that the lack of just consideration from the public at large has been suffered quietly along with a host of other abuses in our social organization. Now, however, scores of well-established machinery concerns, representing the most intelligent and progressive manufacturing class of the nation, and tens of thousands of engine owners and operators, are directly concerned with the future of the tractor. Indirectly, but no less actually, the whole population of the country, and of our rural districts in particular, is interested in the attitude of public officials toward

it. Its unrestricted development as an aid to mankind depends upon this attitude, which in the past has been neutral, even hostile. In the future the embarrassments which have been imposed must be removed, and constructive measures must be taken to widen the tractor's sphere of usefulness, or else the great opportunity which is offered by this cheap, convenient, and efficient servant of humanity will fall short of a full realization.



## SPECIFICATIONS OF LEADING GAS TRACTORS

(1) Specific gravity = weight (lbs. per gallon)  $\times$  12

(2) Weight (lbs. per gal.) =  $\frac{\text{specific gravity}}{12}$

(3) Baume gravity =  $\frac{140}{\text{specific gravity}} - 130$

(4) Specific gravity =  $\frac{140}{130 + (\text{Baume gravity})}$

(5) Indicated horsepower (I.h.p.) =  $\frac{P \times L \times A \times N}{33000}$

in which P = mean effective pressure (M.E.P.) in pounds per square inch; L = length of stroke in feet; A = area of piston in inches; N = number of power impulses per minute.

(6) For steam engines:

$$\text{I.h.p.} = \frac{2PLAN}{33000}$$

(7) For four-cycle, single-acting, throttle-governed gas engines:

$$\text{I.h.p.} = \frac{PLAN}{33000 \times 2}$$

(8) Brake horsepower (B.h.p.) =  $\frac{2 \times 3.1416 \times L \times N \times F}{33000}$

in which L = length of brake arm; N = r.p.m. of flywheel; F = weight on scale beam.

(9) Drawbar h.p. = speed (mi. per hr.)  $\times$   $\frac{\text{drawbar pull}}{375}$

(10) Mechanical efficiency =  $\frac{\text{B.h.p.}}{\text{I.h.p.}}$

$$(11) \text{ Tractive efficiency} = \frac{\text{Drawbar h.p.}}{\text{B.h.p.}}$$

$$(12) \text{ Thermal efficiency} = \frac{2545}{\text{B.t.u. supplied per h.p.-hr.}}$$

(13) Roberts' formula for rating small gas engines:

$$\text{B.h.p.} = \frac{D \times L \times R \times N}{18000} \text{ for four-cycle engines,}$$

$$(14) \text{ and } \frac{D \times L \times R \times N}{13600} \text{ for two-cycle engines,}$$

in which D = diameter of cylinder in inches; L = length of stroke in inches; R = revolutions of crankshaft per minute; N = number of cylinders.

Draft of different numbers of 14-inch stubble plows in sandy loam soil of an Illinois cornfield, based on thesis of C. A. Ocock, at Urbana, Ill., in 1904. Average of 90 tests at each depth, 30 in wet, 30 in dry, and 30 in ideal soil conditions:

No. of 14" Bottoms	1	2	3	4	5	6	7	8	9	10	11	12	13	14	Draft per Sq. In. Cross Section
4"	290	579	869	1158	1448	1737	2027	2316	2606	2895	3185	3474	3764	4053	5.17
5"	340	680	1021	1361	1701	2041	2381	2722	3062	3402	3742	4082	4423	4763	4.86
6"	401	801	1202	1603	2003	2404	2805	3205	3606	4007	4407	4808	5209	5609	4.77
7"	448	896	1344	1791	2239	2687	3135	3583	4031	4479	4926	5374	5822	6270	4.57
8"	505	1010	1515	2020	2526	3031	3536	4041	4546	5051	5556	6061	6567	7072	4.51

Three-wheeled sulky plows used in all tests. For draft of engine gang plows under the same condition add from 10 to 25 per cent. For heavier soils add from 25 to 200 per cent.

Capacity of plowing outfits in acres per hour at different speeds, for furrows of varying width and number. Formula: Miles net furrow travel and width in feet of strip plowed ÷ 8.25 = Acres:

Size of Furrow	8 inches					10 inches					12 inches	
	1.5	1.75	2.0	2.25	2.5	1.5	1.75	2.0	2.25	2.5	1.5	1.75
Miles per Hour												
No. of Furrows												
1	.12	.14	.16	.18	.20	.15	.18	.20	.23	.25	.18	.21
2	.24	.28	.32	.36	.40	.30	.35	.40	.45	.51	.36	.42
3	.36	.42	.48	.55	.61	.45	.53	.61	.68	.76	.55	.64
4	.48	.56	.65	.73	.81	.61	.71	.81	.91	1.01	.73	.85
5	.61	.71	.81	.91	1.01	.76	.88	1.01	1.14	1.26	.91	1.06
6	.73	.85	.97	1.09	1.21	.91	1.06	1.21	1.36	1.52	1.09	1.27
7	.85	.99	1.13	1.27	1.41	1.06	1.24	1.41	1.59	1.77	1.27	1.48
8	.97	1.13	1.29	1.45	1.62	1.21	1.41	1.62	1.82	2.02	1.45	1.70
9	1.09	1.27	1.45	1.64	1.82	1.36	1.59	1.82	2.05	2.27	1.64	1.91
10	1.21	1.41	1.62	1.82	2.02	1.52	1.77	2.02	2.27	2.53	1.82	2.12
11	1.33	1.55	1.78	2.0	2.22	1.67	1.94	2.22	2.50	2.78	2.0	2.33
12	1.45	1.69	1.94	2.18	2.42	1.82	2.12	2.42	2.73	3.03	2.18	2.54
13	1.57	1.83	2.10	2.36	2.62	1.97	2.30	2.62	2.95	3.28	2.36	2.70
14	1.69	1.97	2.26	2.55	2.83	2.12	2.47	2.83	3.18	3.54	2.55	2.97
15	1.82	2.11	2.42	2.73	3.03	2.27	2.65	3.03	3.41	3.79	2.73	3.18
16	1.94	2.26	2.59	2.91	3.23	2.42	2.83	3.23	3.64	4.04	2.91	3.39
17	2.06	2.40	2.75	3.09	3.44	2.58	3.00	3.44	3.86	4.29	3.09	3.60
18	2.18	2.54	2.91	3.27	3.64	2.73	3.18	3.64	4.09	4.54	3.27	3.82
19	2.30	2.68	3.07	3.46	3.84	2.88	3.36	3.84	4.32	4.28	3.46	4.03
20	2.42	2.82	3.23	3.64	4.04	3.03	3.53	4.04	4.55	5.05	3.64	4.24
21	2.54	2.96	3.40	3.82	4.24	3.18	3.71	4.24	4.77	5.30	3.82	4.45

Size of Furrow	12 inches			14 inches					16 inches				
	2.0	2.25	2.5	1.5	1.75	2.0	2.25	2.5	1.5	1.75	2.0	2.25	2.5
Miles per Hour													
No. of Furrows													
1	.24	.27	.30	.21	.25	.28	.32	.35	.24	.28	.32	.36	.40
2	.48	.55	.61	.42	.49	.57	.64	.71	.48	.57	.65	.73	.81
3	.73	.82	.91	.64	.74	.85	.95	1.06	.73	.85	.97	1.09	1.21
4	.97	1.09	1.12	.85	.99	1.13	1.27	1.14	.97	1.13	1.29	1.45	1.62
5	1.21	1.36	1.52	1.06	1.24	1.41	1.59	1.77	1.21	1.41	1.61	1.82	2.02
6	1.45	1.64	1.82	1.27	1.48	1.70	1.91	2.12	1.45	1.70	1.94	2.18	2.42
7	1.70	1.91	2.12	1.48	1.73	1.98	2.22	2.47	1.70	1.98	2.26	2.55	2.83
8	1.94	2.18	2.42	1.70	1.98	2.26	2.54	2.83	1.94	2.26	2.58	2.91	3.23
9	2.18	2.46	2.73	1.91	2.22	2.54	2.86	3.18	2.18	2.54	2.91	3.27	3.64
10	2.42	2.73	3.03	2.12	2.47	2.83	3.18	3.54	2.42	2.83	3.23	3.64	4.04
11	2.66	3.00	3.33	2.33	2.72	3.11	3.50	3.89	2.66	3.11	3.57	4.00	4.44
12	2.91	3.27	3.64	2.54	2.97	3.39	3.82	4.24	2.91	3.39	3.88	4.36	4.85
13	3.15	3.54	3.94	2.76	3.22	3.68	4.14	4.59	3.15	3.68	4.20	4.73	5.25
14	3.39	3.82	4.24	2.97	3.46	3.96	4.45	4.95	3.39	3.96	4.52	5.09	5.66
15	3.64	4.09	4.54	3.18	3.71	4.24	4.77	5.30	3.64	4.24	4.84	5.45	6.06
16	3.88	4.36	4.85	3.39	3.96	4.52	5.09	5.65	3.88	4.52	5.17	5.82	6.46
17	4.12	4.64	5.15	3.60	4.21	4.81	5.41	6.00	4.12	4.81	5.49	6.18	6.87
18	4.36	4.91	5.45	3.82	4.45	5.09	5.72	6.36	4.36	5.09	5.82	6.55	7.27
19	4.61	5.18	5.76	4.03	4.70	5.27	6.04	6.71	4.61	5.37	6.14	6.91	7.68
20	4.85	5.46	6.06	4.24	4.95	5.65	6.36	7.07	4.85	5.65	6.46	7.27	8.08
21	5.09	5.73	6.36	4.45	5.19	5.94	6.68	7.42	5.09	5.94	6.78	7.64	8.48

Horsepower and draft required to pull a 27,000-lb. tractor over various grades and road surfaces at a net speed of 1.9 miles per hour (no allowance for slippage), calculated from actual tests on the same day on level surfaces at speeds of from 1.77 to 1.99 miles per hour:

GRADE		MACADAM ROAD		FIRM EARTH ROAD NOT STICKY		SOFT MUDDY ROAD		SOFT FIELD	
FEET PER MILE	PER CENT.	DRAFT	H.P.	DRAFT	H.P.	DRAFT	H.P.	DRAFT	H.P.
Level	0	2135	10.82	2500	12.67	2650	13.43	3040	15.40
53	1	2405	12.19	2770	14.04	2920	14.80	3310	16.77
106	2	2675	13.55	3040	15.40	3190	16.16	3580	18.14
158	3	2945	14.92	3310	16.77	3460	17.53	3850	19.51
211	4	3215	16.29	3580	18.14	3730	18.90	4120	20.88
264	5	3485	17.66	3850	19.51	4000	20.27	4390	22.44
422	8	4295	21.76	4660	23.61	4810	24.37	5200	26.35
528	10	4835	24.50	5200	26.35	5350	27.11	5740	29.08
634	12	5375	27.24	5740	29.08	5890	29.84	6280	31.82
792	15	6185	31.34	6550	33.19	6700	33.95	7090	35.93

It will be noted that the percentage of variation in draft between different road surfaces is not so great as for wagons; also that the draft ranges from about 160 to 225 pounds per gross ton. These drafts per ton are higher than are usual with wagons, and may be partly ascribed to the greater internal friction. A ton of engine weight pulled about 19 per cent. harder than a ton of wagon and load at the Winnipeg motor contest of 1909. The speed of travel for the tests reported in this table was 1.95 for macadam; 1.93 for firm dirt; 1.77 for soft, muddy road, and 1.67 for the soft field. The tractor pulling this load was designed to run at 2.05 miles per hour on low gear, hence the slippage under the various conditions ranged from about 5 to 18.5 per cent. If a constant figure for friction of gearing, etc., were subtracted from the draft per gross ton in each case, and for the better surfaces possibly a trifle more in proportion as the speed increases, the difference in draft due to road surface would be more strongly emphasized. On grades, the friction and ground resistance are constant, for all practical purposes, variation being due to the lift on the tractor alone. In actual pulling, the internal friction would be



increased to an undetermined extent, hence possibly 250 pounds of resistance per ton of tractor weight would be none too much to allow on the level in order to estimate the horsepower required to move a tractor over an ordinary road. Each per cent. of grade adds 20 pounds per ton to the resistance. For example: A tractor weighs 8 tons and moves at 2.5 miles per hour up a 4 per cent. grade. What power does it take to move it?

$$(8 \times 250) \times (8 \times 4 \times 20) = 2640 \text{ pounds.}$$

$$\frac{2640 \times 2.5}{375} = 17.6 \text{ h.p.}$$

## EFFECT OF VELOCITY ON DRAFT

Relative draft of a stage coach and passengers on Holyhead Turnpike, in England, at different speeds of travel. Based on table of dynamometer tests reported by Trautwine:

PROPORTIONAL ASCENT		4 MILES PER HOUR	6 MILES PER HOUR	8 MILES PER HOUR	10 MILES PER HOUR
FEET	PER CENT.				
One in 15.5	6.45	100	102.9	107.1	114.2
20.	5.0	100	103.1	108.1	116.9
26.	3.85	100	103.2	107.1	113.0
30.	3.33	100	103.7	107.3	112.4
40.	2.5	100	105.2	108.8	114.1
64.	1.56	100	105.5	110.1	115.6
118.	.85	100	104.9	110.8	117.7
138.	.73	100	104.0	110.1	118.2
156.	.64	100	103.0	108.1	114.3
245.	.40	100	103.2	108.6	115.1
600.	.17	100	105.0	112.3	118.6
Level	0.	100	105.2	111.9	119.8
Average.		100	104.1	109.2	115.8

## HAULING

*Theoretical Capacity of Tractors on Grades*

Assumed: Tractors delivering at all times exactly the brake h.p. which will produce the rated drawbar horsepower on the level; ground resistance uniform, at 160 lbs. per gross ton of load and wagon; increase of resistance due to grade 20 lbs. per ton for each 1 per cent; no slippage, speed constant. No account taken of overload capacity of tractor, all of which would be exerted on the load, with marked increase in amount hauled. This table is merely to show the loss due to grades which increase the draft of load and decrease the power of the tractor.

WORKING CONDITIONS ASSUMED	TRACTOR NO. 1		TRACTOR NO. 2
	LOW GEAR	HIGH GEAR	
Speed of travel, miles per hour	2.0	2.75	1.9
Working weight of tractor, lbs.	15000	15000	27000
Drawbar h.p. developed	15	15	30
Drawbar pull.	2810	2045	5920
Draft per gross ton on level, lbs.	160	160	160
Load on level	35100	25600	74000
Do. on 1% grade.	29500	21100	62800
Do. on 2% grade.	25100	17500	53800
Do. on 3% grade.	21500	14500	46500
Do. on 4% grade.	18400	12000	40300
Do. on 5% grade.	15600	10000	35200
Do. on 8% grade.	10000	5300	23500
Do. on 10% grade.	7300	3000	17900
Do. on 12% grade.	5100	1200	13400
Do. on 15% grade.	2400	0	8100

EFFECT OF GRADE ON DRAFT

Relative draft of a stage coach and passengers as ascertained by dynamometer trials on various ascents on the Holyhead Turnpike, England. Comparison based on draft on level. Table based on one by Trautwine.

PROPORTIONAL ASCENT		AT 4 MI. PER HR.	AT 6 MI. PER HR.	AT 8 MI. PER HR.	AT 10 MI. PER HR.	AVERAGE
FEET	PER CENT.					
One in 15.5	6.45	276.2	270.0	264.7	264.0	268.7
20.0	5.00	258.0	252.5	249.6	251.8	253.0
26.0	3.85	204.0	200.0	195.3	192.3	197.9
30.0	3.33	180.2	177.5	173.0	169.3	175.0
40.0	2.50	50.0	150.0	146.0	143.0	147.3
64.0	1.56	143.5	143.8	141.3	138.5	141.8
118.0	0.85	134.1	133.8	133.0	132.0	134.2
138.0	0.73	130.2	128.8	128.3	128.7	129.0
156.0	0.64	129.0	126.3	124.8	123.1	125.8
245.0	0.40	122.4	120.0	118.9	117.7	119.8
600.0	0.17	106.7	106.2	107.1	105.6	106.4
Level	0.00	100.0	100.0	100.0	100.0	100.0

FUELS FOR GAS TRACTORS

KIND OF FUEL	BAUME GRAVITY	SPECIFIC GRAVITY	POUNDS PER GALLON	POUNDS PER BBL. (42 GAL.)
Crude oil	12	.9863	8.223	345.4
"	16	.9600	8.004	336.2
"	28	.8889	7.407	311.1
"	35	.8521	7.101	298.2
Distillate	39	.8324	6.937	291.4
Kerosene	44	.8090	6.742	283.2
Naphtha	50	.7826	6.522	273.9
Gasoline	60	.7423	6.186	259.8
"	64	.7272	6.060	254.5
"	72	.6990	5.825	244.7
"	76	.6857	5.715	240.0
Alcohol 90%	39	.8340	6.95	291.9

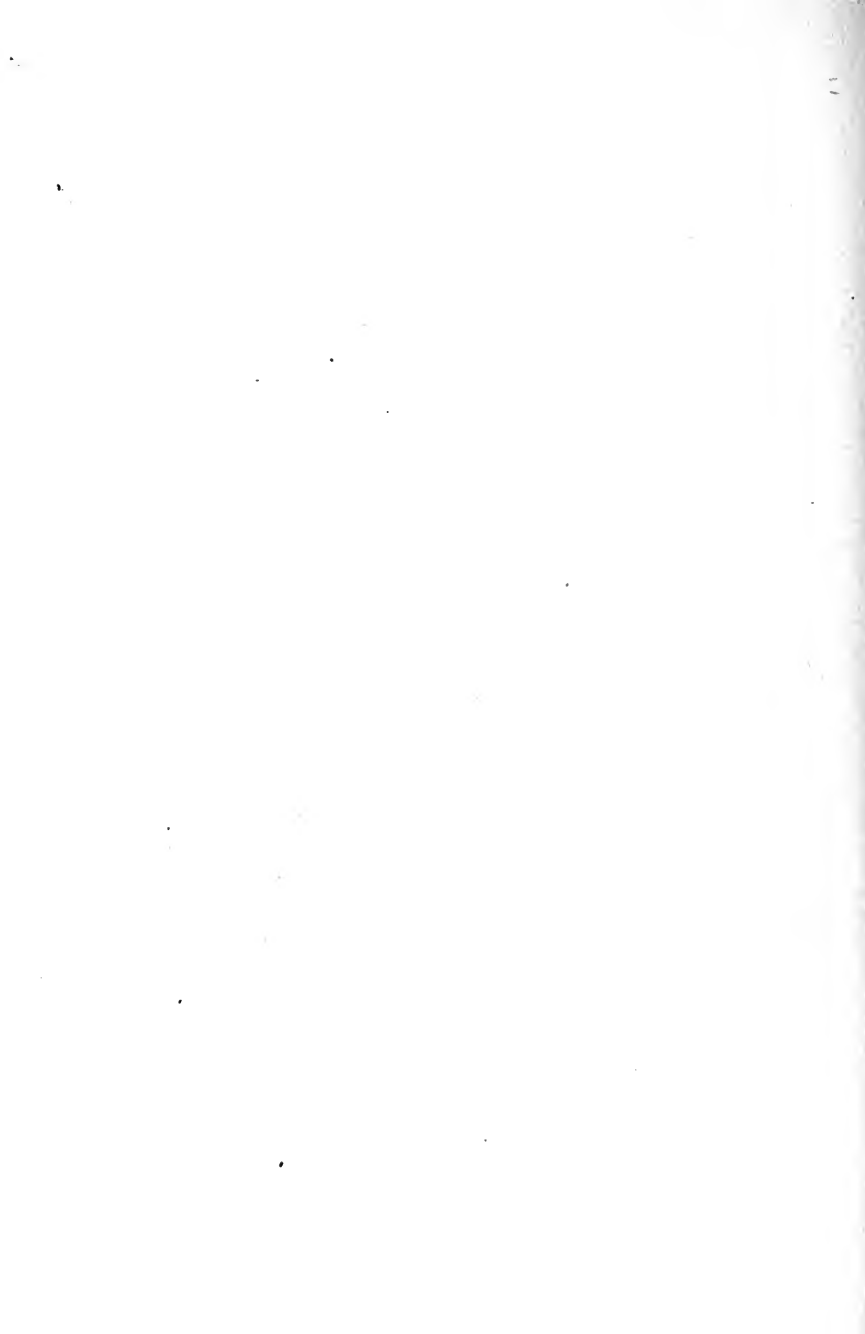

## LIST OF AUTHORITIES CONSULTED

- Elementary Dynamics, E. T. Ferry.  
Cyclopedia of American Agriculture, L. H. Bailey. The Macmillan Co., New York.
- Articles by Thos. F. Hunt, H. P. Armsby, P. S. Rose, Le Grand Powers, C. S. Plumb, J. B. Davidson, John W. Gilmore, C. J. Zintheo, F. H. King, F. B. Mumford, W. L. Carlyle, John A. Craig, C. F. Cutiss, H. W. Quaintance, H. C. Taylor.
- The Animal as a Machine and Prime Mover, R. H. Thurston. John Wiley & Sons, New York.
- The Horse, Youatt. Orange Judd Co., New York.
- Judging Live Stock, John A. Craig.
- United States Office of Experiment Stations, Bulletin 125, Recent Experiments in Horse Feeding. C. F. Langworthy.
- United States Department of Agriculture, Bureau of Statistics, Bulletins 48 and 73. Cost of Producing Farm Products in Minnesota.
- Mechanical Engineers' Handbook, William Kent. John Wiley & Sons, New York.
- Civil Engineers' Pocketbook, J. C. Trautwine.
- Royal Agricultural Society of England, *Journal*, 1871. Report of Agricultural Motor Trials at Wolverhampton.
- The Past, Present, and Future of Steam on the Common Road, R. H. Thurston.
- English and American Steam Carriages and Traction Engines, William Fletcher. Longmans, Green & Co., New York.
- The Traction Engine, J. H. Maggard. David McKay, Philadelphia.
- Rough and Tumble Engineering, J. H. Maggard. *The American Thresherman*.
- Farm Engines and How to Run Them, James H. Stephenson. F. J. Drake & Co., Chicago.
- Instructions for Traction and Stationary Engineers, Wm. Boss.
- Heath School of Traction Engineering, E. H. Heath & Co., Ltd., Winnipeg, Man.
- Farm Machinery and Farm Motors, J. B. Davidson and L. W. Chase. Orange, Judd Co., New York.
- The Gas Engine, F. R. Hutton, John Wiley & Sons, New York.
- Practical Gas Engine, E. W. Longanecker, Anderson, Ind.
- The Chemist's Manual, H. A. Mott, Jr. D. Van Nostrand Co., New York.
- Liquid and Gaseous Fuels, Vivian B. Lewes. D. Van Nostrand Co., New York.
- The Problem of Our Gasoline Supply, *Motor*, New York, September, 1910.
- United States Department of Agriculture, Farmer's Bulletin 277, The Use of Alcohol and Gasoline in Farm Engines.

Oklahoma Geological Survey, Norman, Okla., Bulletin 1, Mineral Resources of Oklahoma.

Past, Present, and Future of the Plow Industry, J. L. Bowles. *American Exports*, New York, March 1910.

*Transactions* New York State Agricultural Society, 1867, Article by J. S. Gould.

Physics of Agriculture, F. H. King.

Missouri Experiment Station, Bulletin 13, Draft Tests, J. W. Sanborn.

Utah Experiment Station, Bulletins 4 and 7, Draft Tests, J. W. Sanborn.

Draft of Plows, Thesis, C. A. Ocock. University of Illinois, 1904.

Department of Agriculture, Saskatchewan, Bulletin 21, Methods of Soil Cultivation, J. R. Motherwell.

United States Department of Agriculture, Yearbook, 1909. The Farmers' Coöperative Demonstration Work, S. A. Knapp.

Office of Public Roads, Report to the Country Life Commission, 1908.

Bureau of Statistics, Bulletin 49, Cost of Hauling Crops.

Twelfth Census of the United States.

Moto-Culture, A. Ph. Silbernel. *Oa Genie Rural*, Paris.

Miscellaneous Articles from: *Implement and Machinery Review*, London; *Canadian Thresherman and Farmer*, Winnipeg, Man.; *Gas Power Age*, Winnipeg, Man.; *Modern Power*, Winnipeg, Man.; *American Thresherman*, Madison, Wis.; *Threshermen's Review*, St. Joseph, Mich.; *Gas Power*, St. Joseph, Mich.; *Gas Review*, Madison, Wis.; *Gas Engine*, Cincinnati, O.; *Gas Energy*, New York; *Farm Implement News*, Chicago; *Farm Machinery*, St. Louis, Mo.; *Irrigation Age*, Chicago.

*World's Work*, Garden City, N. Y., August, 1910, The Passing of the Man with the Hoe, Edward A. Rumely.

Papers by L. W. Ellis:

*Journal* American Society of Mechanical Engineers, March 1911; The Economic Importance of the Farm Tractor; United States Bureau of Plant Industry, Bulletin 170; Traction Plowing.

*Transactions* American Society Agricultural Engineers, 1910, Tractive Efficiency.

*Proceedings* National Gas and Gasoline Engine Trades Association, June, 1910, The Gas Tractor and the Horse.

*Proceedings* North Dakota and Northwestern Minnesota Implement Dealers, February, 1911, The Future of the Gas Tractor.

*La Hacienda*, Buffalo, N. Y., August and September, 1910, The Traction Engine in Dry Farming.

*Canadian Thresherman and Farmer*, Winnipeg, Man., The Tractor vs. the Horse, March 1910; Draft of Farm Implements, August, 1910; What Power means to the Future, April 1911.

*American Thresherman*, Madison, Wis., March 1911, Substitutes for Direct Traction.

*Thresherman's Review*, St. Joseph, Mich., The Plows Behind the Engine, Causes for Traction Failures.

*Gas Review*, Madison, Wis., Traction Farming: A source of New Problems in Farm Economics, March 1910; Fuels for Internal-Combustion Engines, November 1910.







**U.C. BERKELEY LIBRARIES**



**C005282670**

