



This is a digital copy of a book that was preserved for generations on library shelves before it was carefully scanned by Google as part of a project to make the world's books discoverable online.

It has survived long enough for the copyright to expire and the book to enter the public domain. A public domain book is one that was never subject to copyright or whose legal copyright term has expired. Whether a book is in the public domain may vary country to country. Public domain books are our gateways to the past, representing a wealth of history, culture and knowledge that's often difficult to discover.

Marks, notations and other marginalia present in the original volume will appear in this file - a reminder of this book's long journey from the publisher to a library and finally to you.

Usage guidelines

Google is proud to partner with libraries to digitize public domain materials and make them widely accessible. Public domain books belong to the public and we are merely their custodians. Nevertheless, this work is expensive, so in order to keep providing this resource, we have taken steps to prevent abuse by commercial parties, including placing technical restrictions on automated querying.

We also ask that you:

- + *Make non-commercial use of the files* We designed Google Book Search for use by individuals, and we request that you use these files for personal, non-commercial purposes.
- + *Refrain from automated querying* Do not send automated queries of any sort to Google's system: If you are conducting research on machine translation, optical character recognition or other areas where access to a large amount of text is helpful, please contact us. We encourage the use of public domain materials for these purposes and may be able to help.
- + *Maintain attribution* The Google "watermark" you see on each file is essential for informing people about this project and helping them find additional materials through Google Book Search. Please do not remove it.
- + *Keep it legal* Whatever your use, remember that you are responsible for ensuring that what you are doing is legal. Do not assume that just because we believe a book is in the public domain for users in the United States, that the work is also in the public domain for users in other countries. Whether a book is still in copyright varies from country to country, and we can't offer guidance on whether any specific use of any specific book is allowed. Please do not assume that a book's appearance in Google Book Search means it can be used in any manner anywhere in the world. Copyright infringement liability can be quite severe.

About Google Book Search

Google's mission is to organize the world's information and to make it universally accessible and useful. Google Book Search helps readers discover the world's books while helping authors and publishers reach new audiences. You can search through the full text of this book on the web at <http://books.google.com/>

Per. 18611 d. $\frac{118}{25.2}$

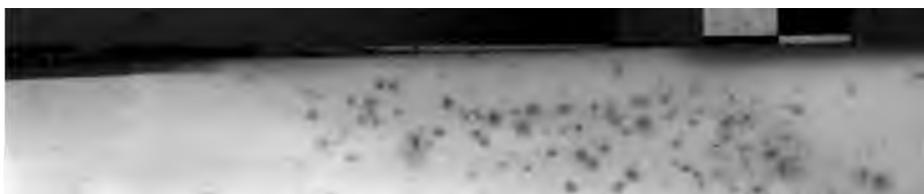

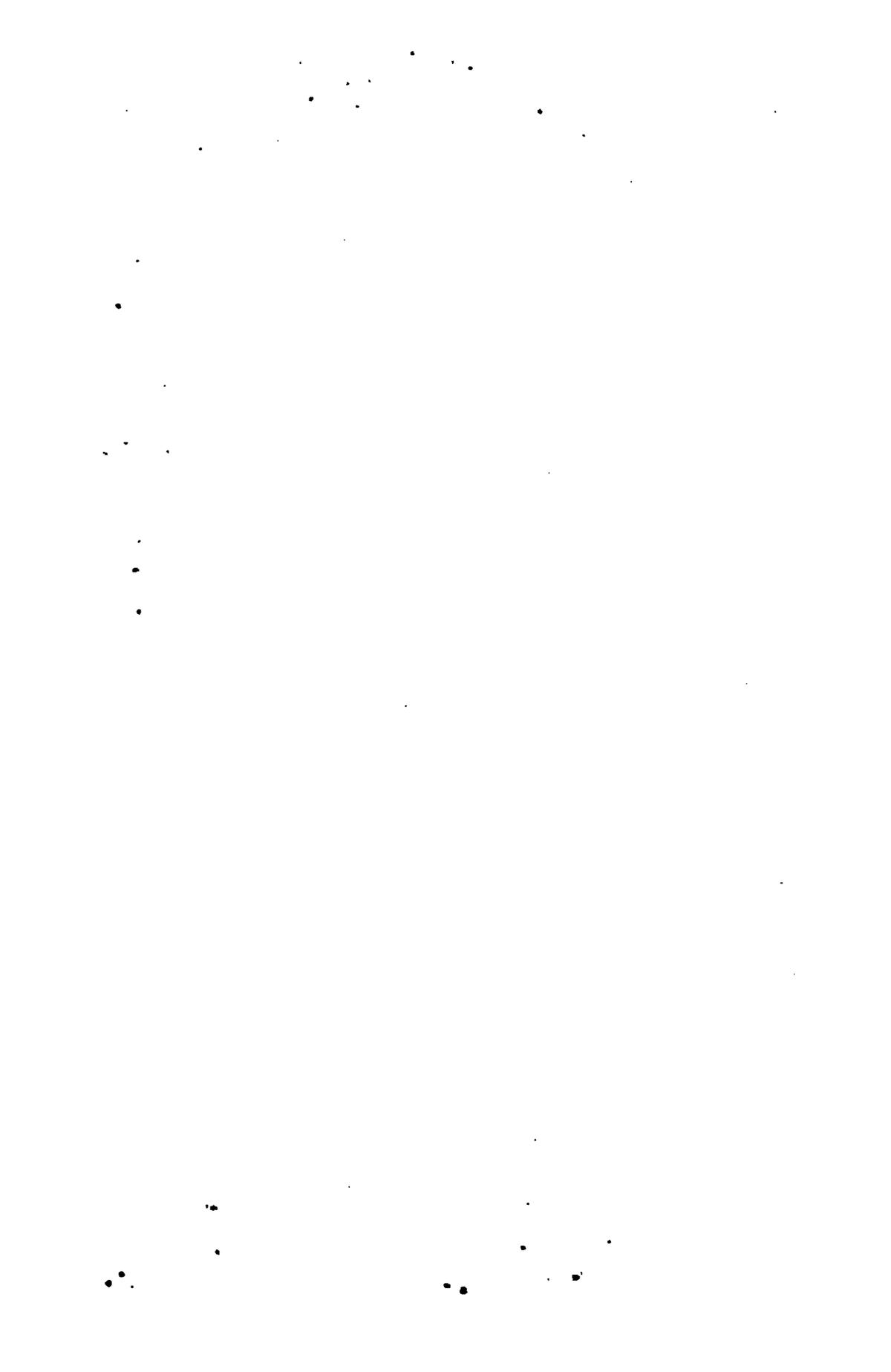









Their completion, Bangalore

MYSORE PUBLIC OFFICES--BANGALORE

McArthur & Currier

PROFESSIONAL PAPERS

ON

INDIAN ENGINEERING.

[SECOND SERIES.]

EDITED BY

MAJOR A. M. LANG, R.E.,

PRINCIPAL, THOMASON C. B. COLLEGE, ROORKEE.

VOL. II.



ROORKEE:

PRINTED AND PUBLISHED AT THE THOMASON COLLEGE PRESS.

CALCUTTA: THACKER, SPINK & Co. BOMBAY: THACKER, VINING & Co.

MADRAS: GANTZ, BROTHERS. LONDON: E. & F. N. SPON & Co.

1878.

[All rights reserved by the Secretary of State for India in Council.]

JAMES JOHNSTON, SUPERINTENDENT.

PREFACE TO VOL. II.

THE Second Volume of the New Series has now been completed: forming the Ninth Volume of "Professional Papers on Indian Engineering" Edited at this College.

Of the thirty-five papers published in this Volume, eighteen relate to Canals, Water-Supply, or works connected with Irrigation: three are descriptive of Public Buildings: four deal with appliances for, or details of Building Construction: four discuss Mortars and Cements: three contain investigations of Stresses in Structures: while Tramways, Rates of Work, and Railway Time Tables have each an Article devoted to them. Thus it will be seen that this publication embraces among its contributors more writers on Hydraulic Engineering than on any other branch of the Profession in this country.

As it is desirable that these papers should present to Indian Engineers descriptions and drawings of the latest works in *all* departments of Engineering in the country, and the results of experience, investigation, calculation or discussion in the many interesting, and often difficult, problems connected with *every* branch of Engineering practice in the country, I would continue to urge on all who take an interest in such questions the claims of this publication to their support. If well supported both by Subscribers and by Contributors of articles from every branch

of the Profession in the Country, these papers cannot fail to furnish a most useful medium of discussion on important Engineering problems, and of disseminating a knowledge of all recent practice: and on these grounds they would seem naturally to claim willing support from every Engineer in this country, both in his own interests, and in those of his fellow workers.

In this present Volume the Articles by Major Hector Tulloch, form a most complete and exhaustive essay (well worthy of careful study) on the History of the Water-Supply of Bombay, and on the several possible modes of improving this supply, together with collateral discussions of questions intimately connected with the general subject of Water-Supply. Capt. Cunningham's Article on the "Stability and Strength of Masonry Well Foundations in Quicksand," is a most valuable contribution to the Mathematics of Engineering, and involves investigations in a problem hitherto almost untried: in this Article the whole subject in all its bearings has been for the first time (I believe) thoroughly and scientifically discussed, and results have been given in a form suitable for the calculations of the practical Engineer.

A third Volume will be commenced in January, to consist of four quarterly numbers issued in January, April, July and October, 1874: the cost being Rs. 14 for Subscribers in advance: but Rs. 4 per quarterly number for those paying in arrears: and for purchasers of single numbers.

A. M. L.

INDEX TO VOL. II.

[SECOND SERIES.]

	PAGE.
Bridge Foundations, Kalsi Suspension. By Lieut. J. T. Wright, R.E., Assistant Engineer, D. P. W.,	310
Brecks' Memorial School at Ootacamund, Nilagirries, Madras Presidency, The. By Capt. J. L. L. Morant, R.E., Assoc. Inst. C.E., F.R.G.S.,	327
Canal of Minimum Cost, The. By A. G. Murray, Esq., C.E., Exec. Engineer,	378
Canal Water, Distribution of. By E. A. Sibold, Esq., Exec. Engineer, Sirhind Canal,	384
Cement, Margohi. By P. Dejoux, Esq., Exec. Engineer, Cement Experiments Division,	9
Clock Tower, Delhi. Communicated by E. J. Martin, Esq., C.E., Exec. Engineer,	111
Country about Bombay, with reference to the "Bombay Water-Supply," Description of the. By Major Hector Tulloch, R.E., ...	215
Dams, Masonry <i>versus</i> Earthen. By Major Hector Tulloch, R.E., Exec. Engineer, Bombay Municipality,	69
Ewoor Project for "The Water-Supply of Bombay," The. By Major Hector Tulloch, R.E.,	245
Excavator, Ives' Patent. By R. T. Ives, Engineer, Department Public Works,	315
Flame-Kiln, Bull's Patent "Oblong." By W. Bull, Esq., C.E., Resident Engineer, O. & R. Railway, Lucknow,	314
Ganges Canal, Eastern. Compiled by Editor,	38
Hydraulic Brake and Tumbler Shutters, Fouracres'. By C. Fouracres, Esq., C.E.,	31

INDEX.

	PAGE.
Kamun Project for "The Water-Supply of Bombay," The. By Major Hector Tulloch, R.E.,	345
Kennery Project for "The Water-Supply of Bombay," The. By Major Hector Tulloch, R.E.,	230
Kunkur Mortars and Concrete, Report on Experiments made on. By A. Nielly, Esq., Assistant Engineer,	115
Level in Canals, Retrogression of. By E. A. Sibold, Esq., Exec. Engineer,	141
Masonry Conduits versus Iron Pipes. By Major Hector Tulloch, R.E.,	157
Offices of the Mysore Government at Bangalore. By Lieut.-Col. R. H. Sankey, R.E., Chief Engineer, Mysore,	1
Pisé, Building in,	408
Pillars, Transverse Strain in. By Capt. Allan Cunningham, R.F., Hon. Fellow of King's College, London,	153
Portland Cement at Kurrachee. By W. H. Price, Esq., M. Inst. C.E., Superintendent, Kurrachee Harbour Works,	324
Puentes Dam, Failure of the. By Capt. C. E. Shepherd, B. S. C., Assoc. Inst. C.E.,	397
Quantity of Water for Various Crops. By W. W. Culcheth, Esq., C.E., Exec. Engineer,	145
Sandstone and Mortar to Thrusting Stress, Resistance of. Report by G. W. MacGeorge, Esq., Exec. Engineer, Kanhan Division,	400
Selenitic Mortar, Experiments on. By Capt. E. V. Twemlow, R.E., Exec. Engineer, Belgaum,	108
Summary and Recommendations for "The Water-Supply of Bom- bay. By Major Hector Tulloch, R.E.,	366
Tansa Project for "The Water-Supply of Bombay," The. By Major Hector Tulloch, R.E.,	331
By Horace Bell, Esq., Exec. Engineer,	

	PAGE.
Water-Supply of Bombay, History of the. By Major Hector Tulloch, R.E.,	173
Well-Foundations, On. By Capt. Allan Cunningham, R.E., Hon. Fellow of King's College, London,	257
Work in Berar, Rates of. By R. G. Elwes, Esq., Asst. Secy. to Govt., Hyderabad,	96

LIST OF PLATES.

PHOTOGRAPHS.

Offices of the Mysore Government at Bangalore (<i>Frontispiece</i>), ...	1
Delhi Clock Tower,	111

ENGRAVING.

Addis' Single-rail Tramway,	319
------------------------------------	-----

LITHOGRAPHS.

Public Offices, Bangalore. Plans and Sections,	2
Example of a Graphic Time Table,	8
Fouracres' Hydraulic Brake. Shutter (32)—Brake and Tumbler Shutter, Elevations and Section,	36
Eastern Ganges Canal. General Map showing the Proposed Eastern Ganges Canal and Branches (38)—Drainage of the Ramgunga Doab,	62
Masonry <i>versus</i> Earthen Dams. Types of French and Spanish Dams (72)—Cross Sections of various forms of Dams (78)—Section of Dam proposed by W. J. M. Rankine, Esq.,	86
Delhi Clock Tower. Ground Plan, Elevation, and Section of Tower,	112
Report on experiments made on Kunkur Mortars and Concrete. Plans and Sections of Perpetual Kiln for Burning Limes and Cements,	128
Retrogression of Level in Canals. Sections showing Retrogression of level on different reaches of the Baree Doab Canal,	142
History of the Water-Supply of Bombay. Capt. Turner's Project	.

	PAGE.
—(176). Sketch from Captain Crawford's Report (180)—Map of the Vehar Valley, Lieut. De Lisle's Project (182)—Plan of the Proposed Lake at Vehar, Lieut. De Lisle's Project (182)—Plan to illustrate Mr. Conybeare's First Project (184)—Plan showing the Vehar Lake, Gathering Ground, and Line of Pipes, Mr. Conybeare's Second Project, (186)—Plan showing method of Filtering and Drawing the water, Mr. Conybeare's Second Project (186)—Contoured Plan of the Vehar Reservoir, Mr. Conybeare's Second Project (188)—Plans and Sections of No. 1 Dam and of Waste Weir (188)—Plans and Sections of Nos. 2 and 3 Dams (188)—Skeleton Map of Bombay showing the Lines of the Main Pipes in the Island (190)—Plan of the Fort and Town, showing the Street Service (190)—Plan of Proposed Reservoir at Shewla, Mr. Aitken's Project (202)—Sections of Shewla and Poway Dams, Mr. Aitken's Project (202)—Kennery Reservoir, Plan and Sections of Dams, Mr. Aitken's Project (204)—Plan of the Poway Reservoir, Mr. Aitken's Project (204)—Plan of the Toolsee Valley and Reservoir, Capt. Tulloch's Project (212)—Toolsee Reservoir, Sections of Dams and Outlet Works, Capt. Tulloch's Project,	212
Description of the Country about Bombay, with reference to the "Bombay Water-Supply." Index Map showing Proposed Project at one view (215)—Sections of Valleys near Dhamnee (218)—Sections across Matheran and Khalapoor Valleys (218)—Section of Mohoghur Valley, Plan of Tondlee Reservoir, and Section of Tondlee Dams (224)—Section across Bhowndi Valley, Plan of Lakewlee Reservoir, and Section of Dam,	226
The Kennery Project for "The Water-Supply of Bombay." Map of Salsette (230)—Contoured Plan of Kennery Reservoir (232)—Sections of Kennery Dam (232)—Sections of Line of Channel from Kennery to Koorla (234)—Plan of Upper Koorla Reservoir, and Sections of Dam (234)—Section of Line of Pipes from Koorla Reservoir to Bombay,	236
The Ewoor Project for "The Water-Supply of Bombay." Contoured Plan of Ewoor Reservoir (246)—Sections of Ewoor Dams (246)—Section of Line of Channel from Ewoor to Koorla,	248

	PAGE.
On Well-Foundations. Vertical Section of Pier and Well, and Velocity and Pressure Diagrams,	294
Bull's Patent "Oblong" Flame Kiln for continuous firing, ...	314
Excavator for Deep Well Foundations. Elevations,	316
Brecks' Memorial School. Ground Plan, Front and End Elevations, Transverse and Longitudinal Sections (328)—Details of Doors and Windows (328)—Details of Roof, Chimney Piece, Cornices, Window, Cill, &c.,	330
The Tansa Project for "The Water-Supply of Bombay." Contoured Plan of Tansa Reservoir (332)—Sections of Tansa Dam (334)— Outlet Works for Tansa and other Projects (334)— Section of the Line of Channel and Pipes from Tansa to Koorla (336)—Section of Line of Channel and Pipes from Tansa to Koorla, (<i>continued</i>),	336
The Kamun Project for "The Water-Supply of Bombay." Contoured Plan of Kamun Reservoir (346)—Sections of Kamun Dams (346)—Section of line of Channel from Kamun to Koorla (348)—Plan of Lower Koorla Reservoir,	350
Distribution of Canal Water. Sketch of Distributing arrangements,	394
Building in Pisé. Plan and Side Elevation of Pisé Box, ...	418
Camp Stove. Plan and Elevations.	

No. LXIII.

OFFICES OF THE MYSORE GOVERNMENT AT
BANGALORE.

[*Vide* Photograph and Plate I.]

BY LIEUT.-COL. R. H. SANKEY, R.E., *Chief Engineer, Mysore.*

FOR some 37 years prior to the construction of the new range of buildings—the east front view of which forms the frontispiece of the present number—the Chief Officers of the Mysore Administration were located in the Fort of Bangalore, and in hired houses at various parts of the station.

Sir Mark Cubbon had continued till his retirement in 1861, to hold his office in the ancient palace of Hyder Ali in the Fort, and notwithstanding the native inscription on this building declaring it to be the “admiration of the heavens,” nothing probably showed more conclusively the stern economy of the old Commissioner’s administration of the finances of the Province, than the fact of his consenting year after year to transact business in this singular old structure. The main block consisted of a long, low, ill-ventilated, ill-flavoured, ill-divided and rickety double storeyed building, which was at once the torment of all who had to use it, and the despair of the Officers who were charged with the duty of preventing it from falling down. All this portion has now been cleared away. An adjoining block which housed the Treasury, Military Assistant’s Office, &c., still stands, and as the architectural features are picturesque, pleasure seekers have found means in the happy application of white-wash, &c., to adapt it for an occasional dance, perfectly regardless of the all pervading dry rot.

The extreme inconveniences of the main building, the fears of sudden collapse, distance from the station, and the nuisance of scattered offices led at length in 1857, to the submission of a project embracing all head quarter offices under one roof; but the mutinies interfering, it was not

till 1860 that the first design went up to the Government of India. This, however, was rejected, and after much discussion, a revised design by the writer of the present notice was accepted, and carried into execution.

No small difficulties presented themselves in the selection of a suitable site, partly from objections to placing the building on any of the military parade grounds, which occupy the only approximately level portions of Bangalore, and partly from the high compensation demanded by private owners for other eligible positions. At length, however, a site was fixed on, which had originally been specially named by Sir Mark Cubbon (whose bronze statue by Marochetti, now appropriately stands in front of the building). It lies immediately beyond the western extremity of the general parade ground, and so far as mere position goes, is as central, with reference to the populations of the Pettah on one side, and the Cantonment Bazaar and Military station on the other, as could be desired; but it fails in some minor points.

From the peculiar conformation of the ground, the building is neither sufficiently elevated, nor is it placed as squarely as could be desired to the parade ground which it fronts. Furthermore the ground sloped away so rapidly, as to necessitate the adoption of a plan of building unduly long with reference to its breadth; and again the whole surface of the ground was so cut into by deep nullahs, (one of which was 90 feet wide and 30 feet deep, while another had been employed always for escalading drill,) and encumbered by rocks, gravel pits, &c., that at first it seemed hopeless to do more than provide standing ground for the work.

By much patient labor, most of the eye-sores which at first were so conspicuous, have now disappeared; and as year by year the trees of the "Cubbon" Park round the Offices increase in number and size, matters will improve, though necessarily the original defects, due to the difficulties of the position, as above explained, must remain, although they may not be so observable.

The general appearance of the buildings as seen from the parade or east side, is shown by the frontispiece. There being no projecting blocks on the west face, the outline is more in repose as viewed from that side.

The following are some particulars regarding amount of accommodation, cost, and constructive features of the work, which having been commenced in October 1864, was finished and occupied by April 1868.

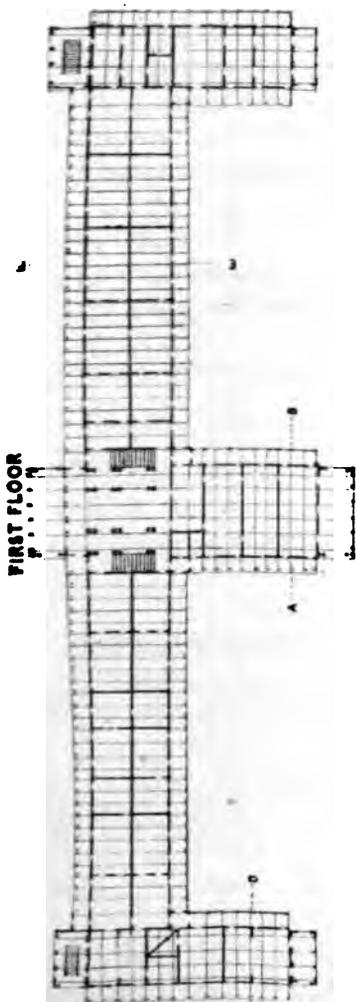

Section on A. B.



Section on C. D.



Section on E. F.



GROUND FLOOR
West

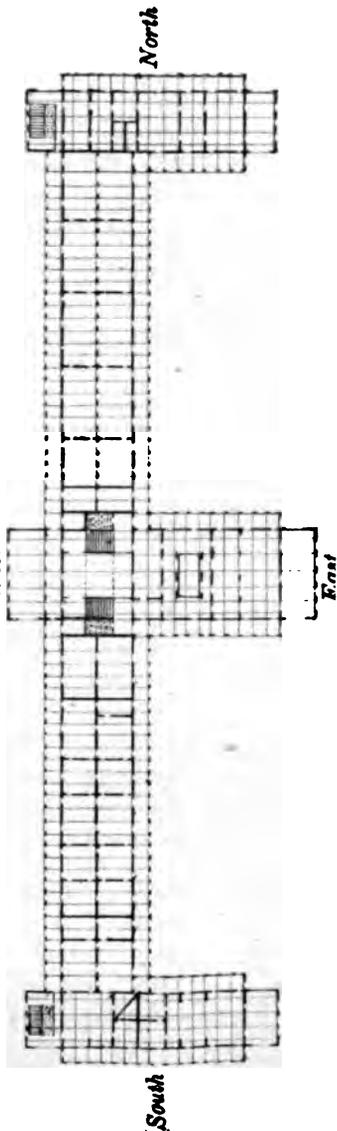

The offices accommodated at present are—

1. Chief Commissioner's, General Secretary, &c.
2. Judicial Commissioner and Court.
3. Chief Engineer and Secretary, P. W. Department, Superintending Engineer for Irrigation, Controller, &c.
4. Director of Public Instruction.
5. Conservator of Forests.
6. Deputy Accountant General and Government Treasury.
7. Superintendent of Government Press.
8. Small Cause Court.

It having been found inconvenient to continue the arrangements made for the Government Press, a new printing office has been under construction, and is now nearly ready for its reception, and the space thus set free will be devoted to other Departments connected with the central administration, viz., the Inam Superintendent, the Military Assistant to the Chief Commissioner, and the "Anchay" or Mysore Post.

The general dimensions of the building are—Total length, North to South, 636½ feet, subdivided thus—

	Length.		Breadth.		Height.	
	ft.	in.	ft.	in.	ft.	in.
Central block,	197	7	74	10½	53	5½
Wings (each),	156	6	55	11	48	8½
Body (two connecting lengths between wings and centre block, each), ..	224	10½	67	10½	44	2½

The spaces provided are—

	Occupied spaces (floors of rooms), square feet.	Unoccupied (verandahs, stair-cases, walls, &c.), square feet.	Total occupied and unoccupied, square feet.
Ground floor,	24,910	35,105	60,015
First "	34,606	25,409	60,015
Second " (in centre block only), ..	5,581	719	6,300
Total, ...	65,097	61,233	126,330

The unoccupied spaces, it will thus be observed, very nearly balance those actually utilized in the shape of rooms and courts. This large proportion is mainly owing to the fact that the main walls of the building on all sides are shaded everywhere from the direct rays of the sun by verandahs or porticoes. The ample provision also made for staircases and intercommunication between the several offices—all of which, moreover, have their separate and distinct entrances—contributes to this result.

Here also it may be observed that from the presence everywhere of verandahs, and the peculiar construction of door adopted, (lower portion being panel, next venetian, upper part glazed, and above all a fan-light ventilator,) hardly a ray of direct sun-light finds its way into the building, while at the same time there is abundant light and ventilation.

The total cost of the building, exclusive of compensation for site, and of levelling, &c. (which was heavy), was Rs. 3,68,981, which taking the area occupied on the outside lines (60,015 square feet) gives the rate over all of Rs. 6-2-4 per square foot of ground plan.

The foundations are everywhere sunk to gravel, which, as a rule, underlies everywhere the red surface soil of much of the Province.

Foundations of	{	Wings,	4 feet deep.
		Central block,	4½ „
		Body,	4 „

and both the foundations themselves, as also the walls in superstructure of the basement and first floor, are throughout built of what is locally termed “burnt stone,” (*i. e.*, gneiss which has been split in laminæ by fire from the parent rock—altogether an unexceptionably fine material) in chunam. In places where old nullahs crossed the site, the foundations go down to 14 feet, and large slabs of stone 6 to 9 feet long, are placed for distributing the pressure.

The walls above the first floor are of brick in chunam. Throughout the whole of the ground floor “burnt stone” slabs 4 inches in thickness, have been employed for flooring both verandahs and rooms, while on the first story, teak-wood planked floors (calculated to bear 60 lbs. on the square foot) are employed. The verandahs here are simple terracing with a matting made from the outer rind of the bamboo, which with a little attention is found to answer very fairly.

The roofing throughout consists of the ordinary description of terracing employed in Southern India (one course of terrace bricks-on-edge, three

inches of concrete, two courses of flat tiles and plaster—weight 68 lbs. per square foot), and the scantlings everywhere employed are taken from the tables calculated by the writer, and published in Vol I. of the “Professional Papers on Indian Engineering” [First Series]. The pent-roofs of wings and central block, though likewise consisting of terraces, have their upper surfaces modelled in imitation of Grecian tiles, and along both ridges, eaves, &c., specially moulded ornamental tiles of correct form have been employed.

The contractors who carried out the building with scrupulous honesty from first to last—Messrs. Wallace, Bumselal Abeerchund, and Narrainswamy Moodlear—showed much resource in all their arrangements, and especially in the ornamental portions, moulding and burning the Ionic volutes of both large and small capitals throughout, in correct form. They likewise made their own arrangements at Moulmein, and shipped the whole of the teak employed in the work, all of first quality. Mr. Wallace, who was the working partner, deserved much credit for the intelligent and painstaking supervision he devoted to the work throughout the whole time it was in hand.

Among other constructive features of the building may be mentioned the disposal of the roof drainage. This is taken down in copper pipes (spaced 25 feet apart generally, with good sinks above, and five inches in diameter through the main walls.

By counter sloping the verandah roofs everywhere, and by making the ends of the pipes debouch into culverts which encircle the building, (from four to five feet below the surface), the whole drainage is thus taken off without running over and disfiguring the outer walls, and is in fact, transferred to points distant from the building.

As this system of disposing of roof drainage has frequently led elsewhere to trouble from the difficulties of adjusting the pipes properly in course of construction, it may be as well to mention that great care was bestowed on this portion of the work from the first. The copper pipes in lengths of four feet, were carried up “*pari passu*” with the walls, and always in advance. The longitudinal seam was knuckle-jointed and rivetted, while the junction of each length of pipe was simply, butt jointed, collared and white leaded.

In course of construction, interference on the part of the work-people had to be continually guarded against, they on some occasions having

been found wantonly to injure or interfere with the pipes: once or twice they managed to throw down a large quantity of mortar and gravel when the walls were well up, thus giving most serious trouble. Considering all attendant difficulties, the results have, however, been very satisfactory.

From first to last, about 20 joints have shown weakness, but these being readily cut down into from the outer faces of the walls, all further leakage has been stopped by making a small basin round the outside of the joint, and pouring in specially prepared plaster of paris. There can be little doubt that instead of being "butt," the pipes should have been spigot and faucet-jointed, which with plaster of paris or cement outside each joint, would have saved all future trouble. As it is, however, the evil is quite a minor one and readily corrected.

The building has now settled most regularly throughout, showing only very slight inequalities of settlement in three places, and these quite unimportant. The roof on the whole has behaved very well. Along the "valley" over the main walls which carries the drainage, a slight yield and "kick" of joists has produced a thin longitudinal crack which give rise to a little "weeping" after heavy rain; but the cure for this is readily applied in the shape of a small parapet wall along the valley weighting and thus preventing any further rise in the ends of the joists. Now that the building has fairly settled, this remedy can be effectually applied. It would no doubt have been better had the small weighting parapet been built during first construction.

The heavy and massive cornices of the central block have also produced a longitudinal crack, and some leakage. The remedy for this, however, will be simple, and it is hoped effective.

Altogether few roofs have probably given less trouble, and the little leakage that exists is susceptible of easy correction.

It was at first proposed to face the building with stone, but the impossibility of doing this was soon demonstrated by the prohibitory cost of cutting the requisite mouldings in the hard "gneiss" of this part of India: plaster surfaces and mouldings had therefore to be resorted to. The system of interior drainage having preserved the surfaces from all run of water, it became of importance to apply a description of coloring which should not in process of time need renewal, and this was effected by grinding up one measure of fresh burnt lime with two measures of clean

river sand, and an sufficient quantity of the light red ochre procurable in every bazar. The resulting wash having a pleasing creamy color, and being applied in the usual way, was found not to rub off after a month, and the whole surfaces are now weathering out satisfactorily. No outer re-coloring should ever be required. The cost of this wash is about 6 annas per 100 square feet.

The following are some of the main items of the work, with rates, as actually executed under contract:—

Description.	Quantity.	RATE.			COST.		
		RS.	A.	P.	RS.	A.	P.
Earth excavation, cubic yards,	7,120	0	1	8	751	6	1
„ filling, „ „	3,462	0	2	8	577	6	0
Stone in chunam (up to 20 feet above } formation level), 100 cubic feet, }	2,83,338	13	14	3	39,352	8	0
Brick in chunam (from 20 to 55 feet, above } formation level), 100 cubic feet, }	2,99,187	19	7	2	58,175	4	0
Arch work in chunam, do., do., ..	31,813	26	0	0	8,253	0	0
Ground flooring (with gneiss slabs &c.), } 100 square feet, .. }	40,954	17	8	0	7,166	15	2
Upper verandah terracing,	19,130	24	0	0	4,591	3	2
Roof terracing, square feet,	37,629	30	0	0	11,288	11	2
„ in imitation of Grecian tiles, sq. ft., ..	21,786	45	0	0	9,803	11	2
Teak wood planked floor,	37,517	50	0	0	18,758	8	2
Wood-work in beams, and joists (teak } wrought and put up), cubic feet, }	27,745	3	8	0	97,107	8	0

R. H. S.

No. LXIV.

GRAPHIC TIME TABLE.

[*Vide Plate II.*]

BY HORACE BELL, *Exec. Engineer, Holkar (State) Railway.*

THE clearness and succinctness of the graphic method has recommended it for adoption in lieu of figure tables in many kinds of business; but it is, somewhat strangely, little used, as far as I am aware, in railway work. For the purposes of a Railway time-table it appears to be admirably suited, as will be seen by reference to the accompanying Plate. The Engineer and his men can see at a glance when they have time to stew a road, take out rails, or lorry, from place to place. Drivers and guards see clearly their time and position in cases of break down, and the traffic department would find it particularly useful in seeing when to put in, or cut out, trains; a point which might save much time, and confusion in running specials, or troop and supply trains, in emergencies or time of war. I first saw a graphic table when passing through Bavaria during the war of 1870, when as may be supposed a large proportion of the trains were "Militärergänzungszüge," (Military supplies.) The tables were lithographed and printed either on paper, or for out-door use, on strong slightly glazed cloth. These latter were, I judged from those I saw, occasionally used for less technical purposes. It will be noted that on single lines the trains cross of course only at stations—on double lines, anywhere. Also, that the quicker a train, the less the angle made with the perpendicular.

H. B.

LE.

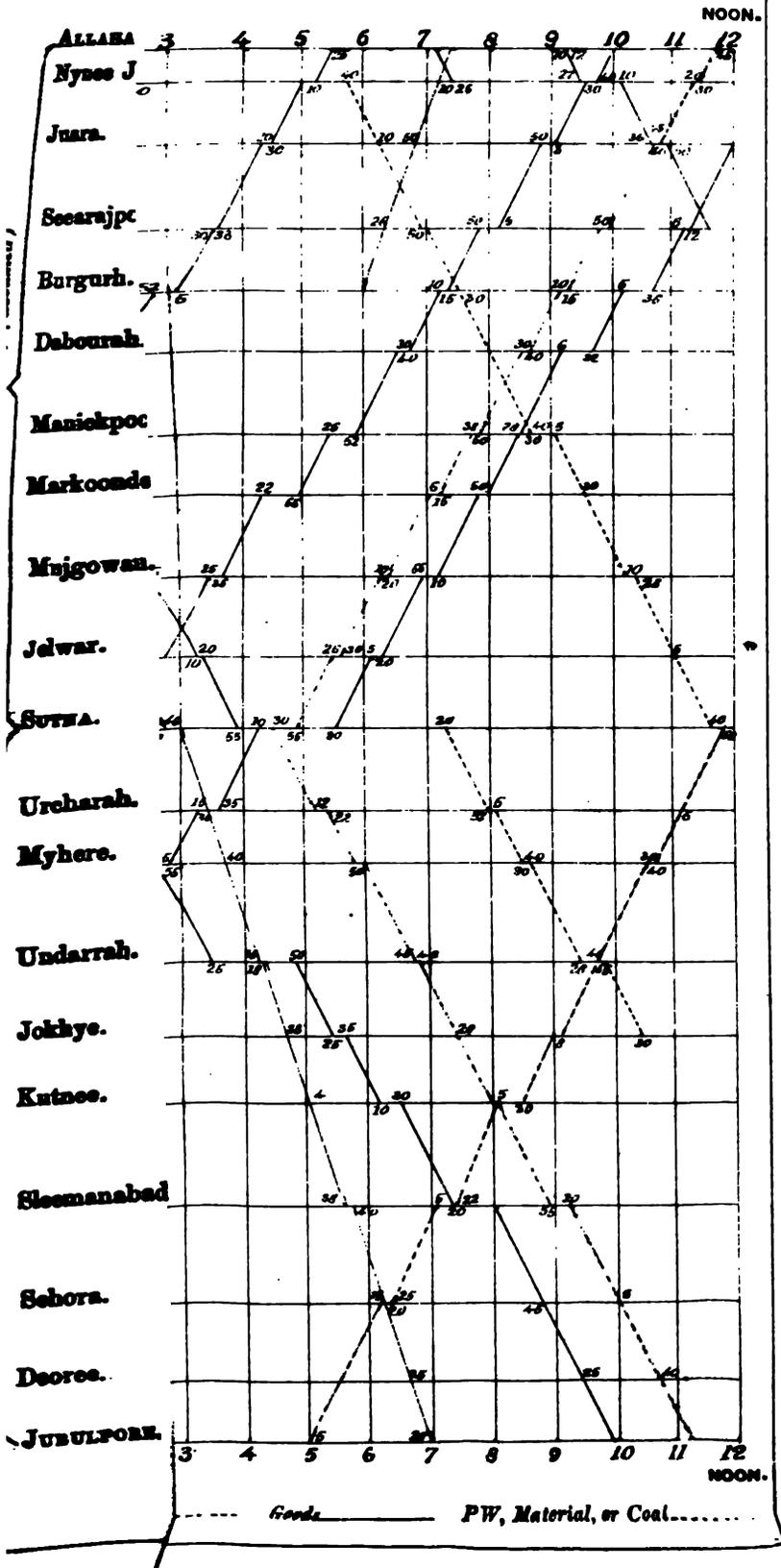

Goods PW, Material, or Coal



No. LXV.

MARGOHI CEMENT.

By P. DEJOUX, Esq., *Exec. Engineer, Cement Experiments Division.*

GENERAL REMARKS ON GHOOTING LIMESTONES.

THE nodular limestone, called *Ghooting* or *kunkur* in India, generally is by its chemical properties the combination of a hydraulic stone and a cement stone, rather a little too rich in clay, so that when the stones are not too hard to break, pulverizing and mixing them with sufficient water to form a rather hard paste, and then making small bricks or balls and burning them sufficiently, will enable the manufacture in some cases of Portland or slow-setting cement, and in other cases a kind of Roman cement or quick-setting cement. When the ghooting is burnt, as is generally done in Bengal, the part which is slaked when taken out from the kiln is the part containing the quantity of clay necessary to make good hydraulic lime; large portions of the parts which are not slaked are those containing more clay and are cement stones; but as generally they contain too large proportions of clay, it will not do to burn those portions again, but, on the contrary, it will be better to burn the whole until they cannot be slaked.

The following details will serve to explain my reasons for adopting this opinion.

I.—When I have to conduct the analysis of a stone of the same kind as a ghooting-stone, I select from a cubic foot of stone a dozen pieces of different shapes, sizes, and appearances; I pulverize them roughly, and mix as much as possible the powder so obtained.

I take afterwards a small quantity of it, and reduce it by means of an agate mortar into an impalpable powder, of which, when dried, I take a quantity weighing 150 grains, and it is on this last quantity that the analysis is conducted.

II.—Proceeding in this way, I found that in the Bengal ghooting-stone the proportion of clay varies from 10·50 to 33·33 per cent., the average, however, being 25 per cent.

Now, if we look to the analysis of the lime believed to be the most hydraulic of all the limes known, viz., the lime of Theil, (France,) we find that the limestone from which that lime is obtained contains only 14·90 per cent. of clay, and we may further say that few hydraulic limestones at home contain more than 15 per cent., and none more than 20 per cent. of clay.

III.—The analysis of the ghooting stones giving an average proportion of 25 per cent., they could naturally be taken for cement stones, but experience proves them to be only argillaceous limestones.

Therefore we can only say that, if the ghooting-stones were more homogeneous, they could have been classified in the category of natural cement stones.

To prove this opinion, I may say that, if we separate some nodules from a piece of ghooting taken in its natural state, it will be found that they generally differ in texture and appearance, and that analysis shows that while some contain as much as 50 and 55 per cent. of clay, others are very nearly pure carbonate of lime.

From the experiments I have made, I feel authorized to say that as regards the generality of ghooting-stones, those which contain from 20 to 25 per cent. of clay are very hydraulic limestones, while those containing only from 10 to 14 per cent. are feebly hydraulic.

As regards those in which the proportions of clay exceed 25 per cent., they produce only a small quantity of lime, and the percentage of portions which cannot be slaked increases proportionately with the quantity of clay.

I have been able to verify the truth of these last remarks in many places in Lower Bengal, where large quantities of ghooting lime are manufactured.

I may, however, state that some ghooting-stones or kunkur may be found sufficiently homogeneous to follow the ordinary rules of hydraulic limestones, but such may very seldom be the case.

IV.—When such a stone as ghooting has been well burnt, all the portions containing less than 20 per cent. of clay slake when immersed in water, but the portions containing an excess of clay, called generally “refuse ghooting” in Bengal, remain inert.

V.—Now, supposing that, after having burnt ghooting-stone containing an average of 20 per cent. clay, the half only of the total quantity (which we will suppose to be 100 cubic feet) slakes and yields an ordinary hydraulic lime; it must be taken as a datum that this lime proceeded from a limestone containing about 10 per cent. of clay.

Consequently the 50 cubic feet of refuse ghooting, which did not slake, must be considered as an argillaceous limestone, containing about 30 per cent. of clay; bearing in mind that the proportion of clay in the total quantity of 100 cubic feet of ghooting was 20 per cent.

Therefore I draw the conclusion that this ghooting must be considered as the agglomeration of two different stones, *i. e.*, while one yields 10 per cent. of clay, and produces an ordinary hydraulic lime, the other contains 30 per cent., and may be transformable into cement.

VI.—Again, supposing that the 100 cubic feet of ghooting contains 30 per cent. of clay, and that we obtain (after slaking) a lime very hydraulic, and 50 cubic feet of refuse ghooting, this lime, according to its degree of hydraulicity, must be considered as proceeding from a limestone yielding about 15 per cent. of clay.

It follows that the refuse ghooting must be considered as an argillaceous stone, yielding about 45 per cent. of clay, and consequently quite useless for the manufacture of either lime or cement.

VII.—Under such circumstances, therefore, we have to consider the two following alternatives, if it be intended to use ghooting for making cements.

In the first case, if the proportion of clay in the refuse ghooting be the proportion generally found in cement stones, we have only to begin by burning the ghooting in the usual way, then to let it slake, separate from the refuse ghooting the lime obtained, and to re-burn the refuse more or less according to requirement for either slow or quick-setting cement.

In the second case, which is the most general, and where the proportion of clay exceeds the limit of the quantity usually found in cement stones, we may follow the theories of Messrs. Minard and Lacordaire (Ingenieurs des Ponts et Chaussées), who are of opinion that some argil-

laceous limestones, of which portions contain clay in excess, may by a long process of calcination with a moderate fire be transformed into cement.

VIII.—The soundness of this fact was nevertheless tested by the experiment I made on the specimen of ghooting-stone A7 from Dinapore, as described in Statement B.

This ghooting yielded a quick-setting cement when calcined with a moderate fire until it would not slake.

We could in such a case as the last use a flame-kiln for calcinating the ghooting to the required degree.

IX.—I must, however, reiterate that it will be more certain and more easy, principally on account of the burning, to choose, for the manufacture of cement, ghooting-stones which, containing the proper proportion of clay, can be easily pulverized, and that in such a case they may be treated similarly as *non-homogeneous marly clay*.

In treating about ghooting limestone, I may as well state that the great defect in hydraulic lime extracted from it and used throughout in Bengal, lies from its not being sifted fine enough. Failures in buildings, are, I believe, ascribable in a great measure to the mortar prepared with this defective lime; for straining ghooting lime properly, however, I am of opinion that no sieves less fine than one of 20 meshes to an inch should be used.

In order, therefore, to give my conjecture a trial and my opinion stability as to the defect above noticed, I made a rough analysis of the ghooting lime used in the Drainage Department of the Calcutta Municipality, and found, as anticipated, the following result:—

Lime,	47.0
Clay,	6.0
Sand,	17.5
Ashes,	4.0
Carbonate of lime, half burnt,	25.5
								100.0

MARGOHI CEMENT.

The Margohi quarries are only 10 miles distant from the head works at Dehree, and about 5 from the tramway at Dhodand, which communicates with the head works.

The quarries are at the foot of the hills, and can be worked very easily.

It is evident at present that the Soane Circle contains such of the best materials as will enable the manufacture of good cement. Of the specimens received, two have been found very suitable for the purpose. These are called in French *Marnes Argiluses* (marly clay); one of these, B6, is very nearly like the *Marne of Boulogne Sur Mer*, which produces a cement which is considered by many Engineers better than the English Portland cement; the other marked B7, sent to me as white clay, is also a *Marne*, and by its combination with B6 will enable the manufacture of a cement of the kind which is commonly called *Roman cement*.

The clays B6 and B7 are very friable, and consequently very easily pulverized; on this account it is certain (by reducing them to that state and eventually forming bricks with them) to secure a good homogeneity.

In Statement B. are given the results of the experiments on cement, a rough analysis of these two descriptions of marly clay.

The samples A1, A2, and A3 may be also considered as cement stones, but the layers of these stones are of different qualities; some are cement stones, and others similar to those called by Vicat *Chaux Limites*, which are always dangerous to use.

Should these stones be, however, burnt to a high temperature and attempts made to slake them with boiling water, the result will be that while the portion containing the *Chaux Limites* gets slaked, the other remains unaffected. I opine, therefore, that they must be rejected on account of their want of homogeneity, and principally on account of the presence of the *Chaux Limites*; nevertheless, I intend making further experiments with them.

The clay from Dehree, B9, contains 8 per cent. of sand, but after washing it may be used with marly clay, and besides it may answer, if necessary, to increase for slow-setting cements the proportion of clay.

On the surface of the ground about the Margohi quarries there is to be found a sandy clay to a depth of 12 to 15 feet, after which a kind of shelly, useless, clay.

This shelly clay is found in great abundance with the yellow clay B77, the latter containing 88 per cent. of clay or sand, and 12 per cent. of carbonate of lime, and under it the yellow marly clay B6, which is also plentiful, but which can very easily be distinguished from the shelly clay.

The fourth strata consisted of blue stones A1 and A2, mixed with the white marly clay B7; and the fifth of white stone A3.

The clay B7 is not to be found in very large quantities, but for the manufacture of cement we could use equally well the white stone A3, which possesses very nearly the same chemical composition, and may be pulverized almost as easily as the white clay.

The rates are as follow :—

Extracting raw materials,	1 rupee per 100 cubic feet.
Breaking ditto,	4 annas ditto ditto.
Carriage from Margohi to Dehree,..	5 rupees ditto ditto.
Coolie labor, per coolie,	from 2 annas to 2 annas 6 pic.
Fire-wood per 100 maunds,	12 rupees 8 annas.
Coal per maund,	9 annas.

Bucknour Quarries.—These quarries are 5 miles distant from Rohtas, 24 from Dehree, and 1 from the River Soane. They are also at the foot of the hills, and the extraction is very easy. I found here a larger variety of stones and clays than at Margohi.

The more hydraulic stones are those which are found on the surface of the earth, In excavating from 6 inches to 1 foot, you arrive at some beds of nearly pure fat lime, but in going in deeper, many varieties of marly clay are found, similar to those got at Margohi.

I was enabled within a very small space of ground to collect as many as eight different kinds of stones, and four of marly clay, varying from the fat lime to stone or clay containing even too much clay for being cement stones, which, however, could be used as puzzuolana.

Analysis subsequently proved to me that the specimen marked A48 will produce a slow-setting cement, and its homogeneity will afford the advantage of burning it in its natural state.

These quarries have heretofore been worked only by natives who manufactured fat lime and sent it to Patna. Some years ago they manufactured as much as 1,25,000 maunds in one year for the railway; but now the annual manufacture varies from 20 to 25,000 maunds only.

When the Soane Canal is opened, there will be every facility for the transport of cement manufactured at these quarries, owing to their vicinity to the river.

The rates at Bucknour are as follow :—

Extracting raw materials,	1 rupee per 100 cubic feet.
Breaking ditto	4 annas ditto ditto.

Carriage from Bucknour to Dehree, ..	7 to 8 rupees per 100 maunds.
Ditto ditto Patna, ..	18 rupees ditto ditto.
Coolie labor, per coolie,	from 1 anna 6 pie to 2 annas.
Fire-wood (rather scarce) per 100 maunds,	7 rupees.
Coal per maund,	8 annas 6 pie.

I think a patient and deliberate exploration of the range of hills from Margohi to Rohtas, will lead to the discovery of several varieties of useful stones. I intend to carry out a careful research personally, if the Government sanctions the construction of a small cement factory at Dehree.

Dehree Division.—My inspection of the quarries of Margohi and Bucknour, and the series of experiments I have already made on the specimens from those quarries, confirm me in the opinion that this is, for the present, the best place for manufacturing both slow and quick-setting cements.

Cement Experiments.—On the 19th of June, upon receipt from the Dehree Division of 160 cubic feet of the following materials, viz., yellow marly clay B6, white marly clay B7, white stone A3, and yellow clay B77, I commenced immediately the manufacture of cements, but instead of hiring monthly or buying a soorkee mill, and an engine for pulverizing the materials, I found it more convenient, and comparatively less expensive to hire one of Messrs. Burn and Company's soorkee mills at Bow Bazaar, at Rs. 18* per day whenever I require it. The materials were sent, and they were very easily reduced in soorkee mills into fine powder, and afterwards I had the following mixtures of raw materials made:—

1st	..	{ 2 parts of B6 1 part of B7 }	In which the average of clay was 22 per cent.
2nd	..	{ 3 parts of B6 1 part of B7 }	Average of clay 23 per cent.
3rd	..	{ 2 parts of B6 1 part of B7 ½ part of B77 }	Average of clay 32½ per cent.

These I put into vats of the reservoir, which I filled with water, and agitated the whole until the appearance of a perfect homogeneity. The water was afterwards allowed to flow off gently, and the deposit is now drying, and I hope, weather permitting, to see it arrive in a few days to a consistence sufficient to enable me to form cakes, &c.

From all the experiments on a small scale I have hitherto made on the shooting stones or kunkur, I feel convinced that it will be possible to make good cement with some of them.

* Including cost of coal, tindal, &c.

MARGOHI CEMENT.

The composition which seems to me at present the best and the most easy to burn for the making of a slow-setting cement is—

2 parts of B6.
1 part of B7.
 $\frac{1}{2}$ part of B77.

It can be burnt near vitrification, and sets in ten hours.

For another quick-setting cement, I consider the following composition the best:—

3 parts of B6.
1 part of B7.

The cement produced from this sets in 35 minutes, and is very easy to use, as it does not set too quickly. It requires a slow heat, and consequently, not much fuel; it must be burnt only near to complete calcination, and consequently ought always to retain a small quantity of carbonic acid. When too much burnt, if immediately used, it produces a very bad result as shown in sample 17A. of statement C.; but if instead of using it immediately it is left exposed for about one month to the air, some carbonic acid returns, and it turns out as good as if not too much burnt; it takes only a little more time in setting. This result is shown by sample 17B.

On account of this peculiarity it will only be necessary, after having taken out of the kiln the cement, which may often contain some portions too much burnt (which are very easily detected with a little practice), to grind and to leave them exposed in open sheds for a certain time before using them.

The same peculiarity exists also in all the cements obtained from the different mixtures of the marly clays B6 and B7.

Another example of it is shown in statement C. by the experiments of 2ivA. and 2ivB.

As regards the quality of cement No. 17, I tried the tractile strength of a certain quantity burn for 100 hours comparatively with the strength of English Portland cement; the *procés verbal* on page xxii. shows the result of the experiments.

I made also balls of mortars composed of—

No. 1 .. { 2 parts of sand,
 .. { 1 part of cement No. 17;
 and

No. 2 .. { 2 parts of sand,
1 part of Portland cement.

No. 1 put under water, two hours after being made, was not affected by the water, and since its hardness has been increasing very sensibly.

No. 2 put under water similarly fell into pieces.

As far as I can judge at present, the probable cost (including burning by coal) of manufacturing a cement equal to No. 17 at Dehree would be as follows:—

	RS.	A.	P.	
Extracting materials,	1	0	0	per 100 c. ft.
Breaking ditto,	0	4	0	" "
Carriage of ditto from Margohi to Dehree,	5	0	0	" "
Grinding raw materials,	10	0	0	" "
Mixing and washing materials, as also mak- ing cakes or balls,	8	0	0	
Loading and unloading kiln,	2	8	0	
Grinding burnt cement,	15	0	0	
Wear and tear of bags per trip at 6 pie per bag,	3	2	0	
	<hr/>			
	39	14	0	
20 maunds of coal at 9 annas per maund,	11	4	0	
	<hr/>			
	51	2	0	
Contingencies, about 20 per cent.,	10	0	0	
	<hr/>			
Total,	61	2	0	

I think that in using a flame-kiln of the kind described by Vicat for the burning of artificial hydraulic lime, we could burn the cement with fire-wood.

In such a case the cost will be as follows:—

	RS.	A.	P.
Extracting carriage, grinding, &c., as above shown, ..	39	14	0
20 maunds of fire-wood, at Rs. 12-8 per 100 maunds, ..	4	2	0
Contingencies, say,	10	0	0
	<hr/>		
	54	0	0

As I have, in calculating the probable cost, used the higher rates which may hereafter be considerably reduced when the works will have assumed a certain importance, I may say that in case of coal being burnt, the cost of the cement will not exceed Rs. 61-2 per 100 cubic feet, or 9 annas 10 pie per cubic foot, or in round numbers 10 annas; but if fire-wood be used, the cost will not exceed Rs. 54 per 100 cubic feet, or 8 annas 6 pie per cubic foot.

PROCES VERBAL.

Experiments on the comparative tractile strength of Cement No. 17 and English Portland Cement (just imported and in very good condition).

Cement No. 17.—Composition, { Three parts of yellow marly clay, } From
 { one part of white marly clay. } Margohi.

Three bricks were joined together by means of a mortar made with this cement, pure, and were left exposed to the air for 24 hours.

These were then put under water for 10 days, and on being taken out were left exposed for two days and 17 hours, and then tried, making a total of 13 days and 17 hours after the manufacture.

Fig. 1.

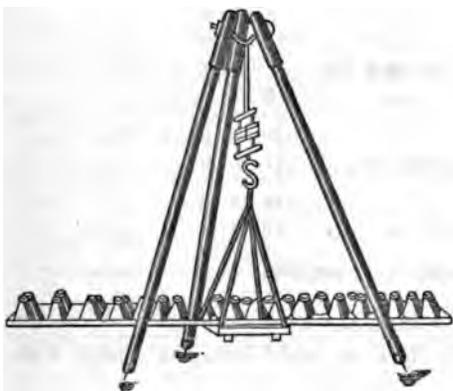
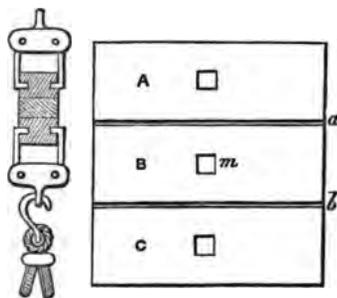

Fig. 2.



I put the block held by the clamps as shown in *Fig. 1*, and loaded it with 1,065 lbs. The block stood without any apparent injury for about three minutes, and then the brick C. give way partially as shown in the accompanying figures.

Fig. 3.



C. Section.

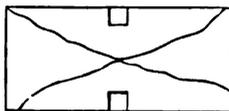

C. Plan.

I made a new hole (*m*) in the centre brick and tried it again.

When loaded with 1,316 lbs., the joint (a) gave way, the first brick A. remaining intact, and the brick B. having a portion *K*. broken (*vide* figures);
 Fig. 4. Fig. 5.

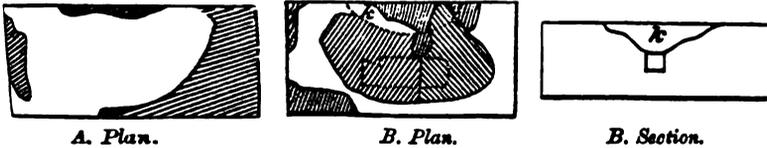

the unshaded parts show the cement which remained attached to bricks A. and B; the shaded portion shows the cement joints separated in pieces upon the two bricks.

The cement inside the joints was found very hard; the bricks were first-rate burnt bricks, but the bricks A. and B. (principally A.) were found sensibly better and harder than C.

In putting the cement mortar between the two bricks A. and B., the precaution of putting an hollow part against a flat one not having been taken, two hollow parts being put together, air got within and left the hollow portion marked in dotted line in *Fig. 5*; the surface of that portion in which the mortar did not touch the brick was 8 square inches.

The total area of the brick was $4\frac{1}{2} \times 9\frac{1}{2}$ square inches = $42\frac{1}{4}$ square inches; deducting from this the 8 square inches above-mentioned, balance of $34\frac{3}{4}$ square inches for the total surface was left, which may fairly be calculated to oppose resistance to the tractile strength, and it may consequently be said that weight of 37·87 per square inch was necessary for the breaking of the joint.

Portland Cement.—The same process as the last answered for this experiment.

I put the block held by the clamps as shown by *Fig. 1*, and loaded it with 1,148 lbs.; the brick C. broke, but at the same time a crack appeared in the joint *b*, and I could separate the bricks B. and C. easily.

The state of the breakage of the brick is shown in *Fig. 6*.

Fig. 6.

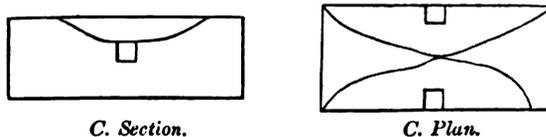

I made a new hole (*m*) (*Fig. 2*) on the brick B. and tried it again.

When loaded with 1,036 lbs., the brick A. broke in the same way as the first one, but the joint remained intact.

Fig. 7 and *8* show how the mortar remained attached to the bricks.

Fig. 7.

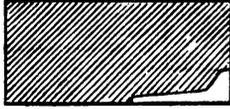

A. Plan.

Fig. 8.



B. Plan.

A small piece of the brick (*f*) broke and remained fixed on the other brick.

In joining these two bricks, some air got in also, and left in the mortar a hollow portion, the surface of which was $1\frac{3}{4}$ square inches; this being subtracted from the total surface of $42\frac{3}{4}$ square inches, the balance was 41 square inches. It may, therefore, be said that a weight of 28 lbs. per square inch was necessary for the breaking of the joint.

NOTE.—I stopped the experiments having the intention of trying the remaining joints intact when they become two months old.

Note by LIEUT.-COL. F. T. HAIG, R.E., *Offg. Chief Engineer, Bengal Irrigation Branch.*

Mr. Dejoux's experiments up to the present time seem to have pretty well established two points.

(1). That a cement quite equal to Portland cement, as received in this country, can be made from a combination of a marly clay and a limestone found close together at the base of the hills skirting the Soane, from the Dehree Stone Quarries at Dhodand to Rohtas, a distance of 20 miles.

(2). That an equally good cement may be manufactured from the Sylhet lime and Calcutta blue clay.

With regard to the first cement, Mr. Dejoux states that any quantity of the materials is available. The strata lie generally near the foot of the hills, which have a rather steep slope; but there will be no need to cut deeply into the face of the hill at any point, which would be expensive, as by going a little further along the hill more of the material can be obtained.

Calculating on the data as to cost of extraction, carriage, &c., afforded by the works at Dehree, for which lime is now brought from Margohi (a point in the hills referred to, about 5 miles from the stone quarries), Mr. Dejoux thinks that the cost of the cement at Dehree would be about Rs. 61 per 100 cubic feet, if coal were used; or Rs. 54, if wood.

The cost of carriage to Arrah by canal would be Rs. 8 per 100 cubic feet.

From Arrah to Calcutta by rail the cost would be Rs. 40 per 100, and from Arrah to Cawnpore by rail Rs. 40.

Thus the cost of the cement in Calcutta would be for—

Carriage—

Dehree to Arrah,	8
Arrah to Calcutta,	40
Terminal charges, shifts, &c.,..	10

	58
Cost of cement at Dehree,	60

Total cost at Calcutta,	118 per 100 c. feet.
---------------------------------	----------------------

The cost at Cawnpore would be—

<i>Carriage—</i>						RS.
Dehree to Arrah,	8
Arrah to Cawnpore,	40
Terminal charges, &c.,	10
						<hr/> 58
				Prime cost,	..	60

Total cost at Cawnpore,.. .. 118 per 100 c. feet.

If the cement were sent by water all the way to Calcutta, the cost there would be about Rs. 100.

The cost of Portland cement in Calcutta is Rs. 9 per cask, containing 5 cubic feet, but there is always a wastage of half a cubic foot, so that the actual cost is Rs. 2 per cubic foot, or Rs. 200 per 100 cubic feet.

Adding railway charges, the cost of the same cement in Cawnpore would be Rs. 290 at least.

Thus the relative costs at each place would be—

<i>Calcutta—</i>						RS.
Portland Cement,	200
Margohi „	100 to 118
<i>Cawnpore—</i>						
Portland Cement,	290
Margohi „	118

These calculations seem sufficient to show that, if the cement can be made for anything like Rs. 60 per 100 cubic feet there would be a very extensive demand for it.

Mr. Dejoux's experiments with the cement manufactured from Sylhet lime have not yet gone far enough to enable him to judge what its cost would probably be, but he thinks it would be about Rs. 100 per 100 c. ft.

Mr. Dejoux also reports that some specimens of kunkur lime sent him by Captain Heywood, which came from a bed somewhere in the Shahabad District, not far from the line of the Arrah Canal, appear to form a natural cement. I am inclined, however, rather to distrust any natural cement produced from this source on account of the want of homogeneity in the material, and think that for the present operations had better be confined to the Margohi stone.

I think there is now quite enough to warrant the commencement of the manufacture of cement at Dehree, or in that neighbourhood, on a small scale. The Soane works alone will require a certain quantity: and if the manufacture is limited, in the first instance, to their requirements, we shall probably, in the course of a year or two, by gradual improvements in the processes, arrive at a really first-rate cement.

TABULAR STATEMENT A.

Rough Analysis of the Specimens which have been burnt for the purpose of making Cement.

No.	Materials from whence obtained.	Composition.	Remarks.
B6	Marly clay from Margohi, ...	Carbonate of Lime ... 60.65 " of Magnesia... 14.35 Oxide of Iron ... 0.67 Clay { Silica ... } 23.33 { Alumina ... } Sand ... 1.00 Total ... 100.00	
B7	Marly clay from Margohi, ...	Carbonate of Lime ... 80.00 " of Magnesia ... Traces, but not appreciable. Oxide of Iron ... Ditto. Clay { Silica ... } 20.00 { Alumina ... } Sand ... 00.00 Total ... 100.00	
A1	Blue stone from Margohi, ...	Carbonate of Lime ... 54.07 " of Magnesia ... 11.00 Oxide of Iron ... 1.33 Clay { Silica ... } 32.00 { Alumina ... } Sand ... 1.60 Total ... 100.00	
A3	White lime-stone, Margohi, ...	Carbonate of Lime ... 75.73 " of Magnesia ... 0.44 Oxide of Iron ... 0.50 Clay { Silica ... } 23.33 { Alumina ... } Sand ... 0.00 Total ... 100.00	
A2	Blue stone $\frac{C}{2}$ from Margohi, ...	Carbonate of Lime ... 81.34 Clay { Silica ... } 16.00 { Alumina ... } Sand ... 0.66 Oxide of Iron ... 2.00 Total ... 100.00	Hydraulic lime-stone containing lime limes in notable proportion.

No.	Materials from whence obtained.	Composition.	Remarks.
A48	Gray lime-stone from Rohtas Hill, 24 miles from Dehree,	Carbonate of Lime ... 72.34 Clay and Sand ... 27.66 (Feeble traces of Oxide of Iron and Carbonate of Magnesia). Total ... 100.00	Cement stone.
B77	Yellow clay found at Margohi, ...	Carbonate of Lime ... 11.34 " of Magnesia ... 0.70 Oxide of Iron ... None. Clay { Silica ... 82.00 Alumina ... Sand ... 6.00 Total ... 100.00	Good for manufacture of slow-setting cement.
A7	Ghooting-stone from Dinapore, ...	Carbonate of Lime ... " of Magnesia ... 77.00 Oxide of Iron ... 1.00 Clay { Silica ... 32.00 Alumina ... Sand ... Not appreciable. Total ... 100.00	

Remarks about the preparation of the samples for cement.

1st.—The samples marked Nos. 1, 2, 3, 4, 5, 6, have been pulverized and passed through a sieve of 60 meshes to one inch. The proportions of each have been carefully measured in volume, after being mixed in water; the water was then removed by decantation, and the mixture left until formed into the consistence of a rather hard paste. Of this paste, balls were made of about 2½ inches in diameter; these balls were exposed to the sun for seven days and burnt in the small kiln with *coke*. When taken out from the kiln, they were pulverized and strained through a sieve of 60 meshes to one inch.

The powder thus obtained was mixed with a little water and made into a rather stiff paste of which while a portion was put into a tumbler and immersed in water, of the other a cake was made and left exposed to the air.

The cement in water eventually was tested with the Aiguille of Vicat.

2nd.—The samples marked Nos. 9, 11, and 12 were not pulverized, but I put only the stones (well washed previously) in the kiln, and after burning sifted them through the same sieve of 60 meshes.

TABLE STATEMENT B.—RESULT OF EXPERIMENTS ON CEMENTS.

Nos.	COMPOSITION.		Hours taken in burning.	In what sort of fire.	Color of stone burnt.	When mixed and put in water.	Time taken for the setting in water.	Quality of the cement under water.	Quality of the cake when exposed to the air.	Result up to 1st April, 1872.	Result up to 30th June, 1872.
	Quantities.	From whence materials were obtained.									
1	1 part of marly clay, B6, 1 ditto, B7,	Margohi.	58	Slow fire.	Reddish gray.	March 20th	4 days.	Rather soft.	Pretty hard.	Requires evidently more burning (it retains carbonic acid).	It has been getting harder and is squibly in cake and in water.
1'	Ditto	Ditto	19	Ditto	Gray.	March 26th.	H. M. 1 15	Very hard.	Very hard.	The hardness has been increasing very sensibly to the present date. (It retains carbonic acid).	Ditto, ditto, but less than 1.
1"	Ditto	Ditto	100	Ditto	White reddish.	March 28th.	40 Ms.	Pretty Hard.	Hard	This will become perhaps after a certain time as good as No 1' (it retains carbonic acid).	As hard as 1' in water, but rather soft in cake.
2	2 parts of marly clay, B6, 1 part of ditto, B7,	Ditto	53	Ditto	Gray.	March 18th.	5 hours.	Hard.	Very hard.	Hardness always increasing (it retains carbonic acid).	It has been getting harder sensibly, and it is even better than 1.
2'	Ditto	Ditto	90	Ditto	Reddish gray.	March 23rd.	H. M. 4 30	Ditto	Hard.	Will become as hard as No. 4, if not more (retains carbonic acid).	It is about or like 1.
2"	Ditto	Ditto	100	Ditto	Gray, greenish.	March 26th.	4 hours.	Pretty hard.	Pretty hard.	I tried two of the balls burnt at the same time, and found the cement of one after 5 days of immersion in water with slight cracks (it retains carbonic acid).	Less hard in cake than in the preceding 2'.

MARGOHI CEMENT.

No.	COMPOSITION.		Hours taken in burning.	In what sort of fire.	Color of stone burnt.	When mixed and put in water.	Time taken for the setting in water.	Quality of the cement under water.	Quality of the cake when exposed to the air.	Result up to 1st April, 1872.	Result up to 30th June, 1872.
	Quantities.	From whence materials were obtained.									
3	1 part of marly clay, B6	Margohi.	58	Slow fire.	Red.	March 16th.	6 days.	Rather hard.	Rather hard.		
3'	Ditto	Ditto	58	Ditto	Gray, reddish.	March 18th.	14 hours	Hard.	Very hard.		
3"	Ditto	Ditto	90	Ditto	Reddish.	March 26th.	H. M. 2 15	Rather hard.	Rather hard.		
3" 1st ball.	Ditto	Ditto	100	Ditto	Gray, greenish.	March 26th.	Not set	Very bad.	Bad.		
3" 2nd ball.	Ditto	Ditto	100	Ditto	Gray.	March 28th.	H. M. 18 30	Rather hard.	Pretty hard.		
4	1 part of marly clay, B7.	Ditto	58	Ditto	Reddish blue.	March 20th.	H. M. 1 30	Very hard.	Very hard.		
4'	Ditto	Ditto	90	Ditto	White.	March 23rd.	H. M. 4 30	Hard.	Hard.		
5	1 part of limestone, A3. 1 part of marly clay, B6.	Ditto	58	Ditto	Gray.	March 18th.	24 hours.	Very hard.	Very hard.		

Requires evidently more burning (retains one which seems pretty good in the series 3.

About the same as 1'.

This is not quite so hard as No. 2 (retains some carbonic acid.

About the same as 1' in water, but the cake is not so hard.

The same as 1.

In water this remains in the state of a very soft paste (retains no carbonic acid).

These two balls were inserted in one. In and the series No. 5 are good were found burnt exactly at the same time: the color was, however, a little different, and slight traces of carbonic acid remained.

The same as 1.

Indifferent.

The cake does not break well (retains little carbonic acid).

This cake is harder than No. 1' and 4 (it retains carbonic acid).

Very hard in water, but bad in cakes.

5'	Ditto	Ditto	90	Ditto	Gray.	March 28rd.	H. M. 4 30	Hard.	Bad.	The cake was getting pretty hard up to the 8th day, after which cracks appeared, and on the 9th day it turned very soft, and began to fall in powder (it retains little carbonic acid).	Hard in water, but in different in cakes.
5'	Ditto	Ditto	100	Ditto	Gray.	March 28th.	19 hours.	Rather hard.	Bad.	After 5 days cracks appeared in the cake, after which it fell in powder (retains no carbonic acid).	Bad.
6	1 part of Marly clay, B6 2 parts of ditto, B7	Ditto	58	Ditto	Gray.	March 20th.	H. M. 1 30	Rather hard.	Very hard.	The cake gets harder by degrees, & at length obtains a very good hardness (retains carbonic acid).	Pretty hard in cakes, but very hard in water.
6'	Ditto	Ditto	90	Ditto	White.	March 26th.	H. M. 1 40	Very hard.	Hard.	After 6 days more thickens will be, I think, better than No. 6 (retains little carbonic acid).	
9	1 part of limestone, A3.	Ditto	58	Slow fire.	White.	March 20th.	4 days.	Indifferent.	Indifferent.	Retains carbonic acid.	
9'	Ditto	Ditto	100	Ditto	White.	March 28th.	16 hours.	Rather soft.	Hard.	Retains little carbonic acid.	
11	1 part limestone, A1,	Ditto	58	Ditto	White yellowish	March 20th.	24 hours.	Pretty hard	Pretty hard.	Retains carbonic acid.	
11'	Ditto	Ditto	90	Ditto	Ditto	March 20th.	4 days.	Rather soft.	Soft.	A small portion of this sample has been slaked in hot water (retains little carbonic acid).	
11'	Ditto	Ditto	100	Ditto	White.	March 28th.	Not set.	Bad.	Very bad.	After 3 days cracks appeared in the cake, and the day after it fell in powder. A small portion also could be slaked in hot water.	

MARGOHI CEMENT.

No.	COMPOSITION.		Hours taken in burning.	In what sort of fire.	Color of stone burnt.	When mixed and put in water.	Time taken for the setting in water.	Quality of the cement under water.	Quality of the cake when exposed to the air.	Result up to 1st April, 1872.	Result up to 30th June, 1872.
	Quantities.	From whence materials were obtained.									
12	1 pt. of ghou- ting stone, A7.	Dinapore	100	Slow fire.	Greenish gray.	March 26th.	35 Ms.	Very hard.	Pretty hard.	The cake has been getting harder very slowly, nevertheless its hardness kept on in- creasing sensibly.	Result up to 30th June, 1872.
13	1 part of marly clay, B6, 1 ditto B7, ..	Margohl.	50	Strong fire.	White.	April 1st.	15 m.	Very bad.	Very bad.		
14	Ditto	Ditto	48	Very slow fire.	Reddish white.	April 30th.	H. M. 1 20	Hard.	Pretty hard.	Retained too much car- bonic acid.	Result up to 30th June, 1872.
211	2 parts of marly clay, B6, 1 ditto B7, ..	Ditto	50	Strong fire.	Grayish white.	April 1st.	10 m.	Very bad.	Very bad.		
2iv	Ditto	Ditto	48	Very slow fire.	Reddish.	April 23rd.	H. M. 1 15	Very hard.	Ditto	Was getting sensibly harder in cake, but crum- bled to powder five days after being made. Con- tained no carbonic acid.	Result up to 30th June, 1872.
2iv ^B	Ditto	Ditto	48	Ditto	Ditto	June 20 th.	1 30	Hard.	Hard.		
2v	Ditto	Ditto	70	Ditto	White.	May 5th.	30 m.	Ditto	Very hard.	Retained little carbonic acid.	Result up to 30th June, 1872.

Slv	1 part B6	Ditto	50	Strong fire.	Gray.	April 1st	Not set	Very hard.	Soft.	
16	2 parts of marly clay, B6 1 part of limestone, A3	Ditto	50	Very strong fire.	Reddish brown.	April 1st	1 m.	Very hard.	Very hard.	{ After three days crumbled to powder in water and cake. Retained no carbonic acid.
16i	Ditto	Ditto	46	Very slow fire.	Reddish.	April 23rd	45 m.	Hard.	Very soft.	{ Required more burning. Was found very hard for nearly three weeks, but after that time the cakes cracked in different places and began to turn soft.
16ii	Ditto	Ditto	60	Ditto	Ditto	April 26th	50 m.	Pretty hard.	Pretty hard.	{ Required a little more burning. Contained much carbonic acid.
17(A)	3 parts of marly clay, B6 1 part of marly clay, B7	Ditto	50	Very strong fire.	Grayish white.	April 1st	5 m.	Very hard.	Very hard.	{ Crumbled to powder in water and cake after five days. Contained no carbonic acid.
17(B)	Ditto	Ditto	50	Ditto	Ditto	May 1st	40 m.	Very hard.	Very hard.	{ Was left exposed to the air for one month, and the absorbent thus of carbonic acid was the cause of its turning good.
17i	Ditto	Ditto	60	Very slow fire.	Reddish.	April 26th.	25 m.	Very hard.	Hard.	{ Retained carbonic acid but required more burning.
17ii	Ditto	Ditto	110	Ditto	Reddish grey.	June 10th	35 m.	Ditto	Very hard.	{ Has had just the burning it required; contains a feeble proportion of carbonic acid. The hardness in this sample increased much more rapidly than in others.
17iii	Ditto	Ditto	48	Very strong fire.	Yellowish gray.	June 10th	10 m.	Very hard.	Very hard.	{ Crumbled to powder in water and in cake two days after.

MARGOHI CEMENT.

Nos.	COMPOSITION.		Hours taken in burning.	In what sort of fire.	Color of stone burnt.	When mixed and put in water.	Time taken for the setting in water.	Quality of the cement under water.	Quality of the cake when exposed to the air.	Recruit up to 1st April, 1872.	Recruit up to 30th June, 1872.
	Quantities.	From whence materials were obtained.									
18	$\frac{4}{3}$ parts of marly clay, B6 1 part of marly clay, B7	Margohi	50	Very strong fire.	Gray.	April 1st	Not set.	Very bad.	Pretty hard.		{ Crumbled to powder in water after 24 hours.
18i	Ditto	Ditto	70	Very slow fire.	Red.	April 30th	50 m.	Hard.	Rather soft.		{ Required evidently more burning.
20	8 parts of marly clay, B7 1 part do., B16	Ditto	50	Very strong fire.	Gray.	May 5th	4 days.	Very hard.	Pretty hard.		{ Could stand more burning with a strong fire.
24	1 part stone, 48A	Rohtas	110	Very slow fire.	Grayish white.	June 10th	2 hours.	Hard.	Hard.		{ Required more burning, and could stand a stronger fire. This will make a good slow setting cement (I had not enough materials to make another experiment).
30	3 parts of marly clay, B6 1 part of marly clay, B7 $1\frac{1}{2}$ parts of marly clay, B77,	Margohi	70	Very strong fire.	Yellow.	June 20th	H. M. 8 15	Pretty hard.	Pretty hard.		{ Its hardness increases very slowly; it required more burning.
30i	Ditto	Ditto	110	Ditto	Grayish yellow.	June 22nd	10 hours	Hard.	Very hard.		{ It was burnt very near vitrification, but I should think it required a little more burning.

Note.—It will be observed from this statement that the best sample is No. 2. It consists of a mixture of { 2 parts of marly clay, B6 } from Margohi, which was burnt with a slow fire. { 1 part of ditto, B7 }

No. LXVI.

FOURACRES' HYDRAULIC BRAKE AND TUMBLER SHUTTERS.

[*Vide* Plate Nos. III. and IV.]

Under-sluices of the Soane Anicut.—In the plan now determined on, each of the three sets of under-sluices of the Soane anicut will be divided into 22 openings, each opening being 20 feet 7 inches in the clear; the piers between the openings will be 4 feet thick and about 30 feet in length, the tops of the piers being 10 feet above the level of the under-sluice floor, and 2 feet above the crest of the weir wall which is to be 9 feet above the sluice floor; about the centre of each opening the level of the floor will be raised 9 inches, and thicker floor stones laid; the object of this is partly for the purpose of having heavier stones where the hinges are fixed, and partly to enable the shutters to lay singly on the floor, and to form a sill for the lower part of the shutter to rest against.

Each opening will be fitted with two shutters; the up-stream one A, is 21 feet 3 inches in length and 9 feet 9 inches high; this shutter is hinged at its lower edge and turns on two strong cast-iron gudgeons C, working in sockets built into the piers, the shutter being 8 inches longer than the width between; the piers will have, when vertical, a bearing of 4 inches on either side against each pier; the piers are recessed to 5 inches deep for the extent required to enable the shutter to oscillate freely between the horizontal and vertical position. At the back of the shutter are fitted 6 back struts, which are the principal novelty in the new system and answer the double purpose of supporting the shutter when vertical, and of breaking the force of concussion against the piers when it is suddenly raised with 9 feet running through, and with a head of 4 or 5 feet.

Each back stay consists of two cast-iron sockets D and E, the first firmly attached to the stone floor, the other to the shutter; in the lower

socket D, is hinged an iron bar F, $2\frac{3}{4}$ inches diameter; in the upper socket E, a rough iron pipe G, $3\frac{1}{2}$ inches internal diameter is also hinged; the bar F, is inserted into the pipe G, and the two thus form a telescopic strut; on the lower extremity of the bar F, is a collar H, and a ring is shrunk on the end of the pipe G. When the shutter is vertical these two are in contact, and the pipe G, thus forms a rigid strut supporting the shutter at the back.

On the rod F, which is half an inch smaller than the pipe, are shrunk two rings forming guides, and above the upper ring is fixed a leather packing similar to that of an hydraulic ram; this packing makes the head of the rod a kind of piston similar to an upper pump-box, which, when exposed to the force of the water, fits tightly into the hollow tube.

In the pipe G, are two small holes; the lower one I, is about 4 inches above the leather packing of the rod F, when the shutter is horizontal and the telescopic joint drawn out to its utmost; the other hole K, is quite at the top of the pipe, a little above the leather packing when the shutter is vertical, and the telescopic joint shut up as far as possible.

The action of these back stays is as follows:—When the shutter is down and the telescopic joint drawn out, the water running through the sluices enters and fills the pipe G, through the holes I, and K, and also probably past the piston, for the leather packing is such, that it becomes loose as the rod is drawn out; the pipe is thus full of water, and as soon as the shutter begins to rise, and the telescopic joint consequently to shut, the leather packing being opposed by the water in the pipe becomes tight and fits closely to the interior of the pipe; the water is therefore forced out of the first or lower hole I, which is larger than the upper one, and consequently more easily permits the efflux of the water; thus when the shutter first commences to rise there is little opposition to its movement, but when it has risen a short distance, and the leather packing has slid past the hole I, all the water remaining in the pipe has to be expelled through the smaller hole K, and consequently a greater resistance is opposed to the shutter, which comes up gradually to the vertical position, violently expelling the water in a jet from the small hole.

The appended report by Mr. Kimber, Executive Engineer, Cossye Division, on experiments with a model shutter, abundantly prove the perfectly successful working of this form of back stay.

A vertical bar L. (with a catch at the lower end worked by a handle on

FOURACRE'S HYDRAULIC BRAKE-SHUTTER.

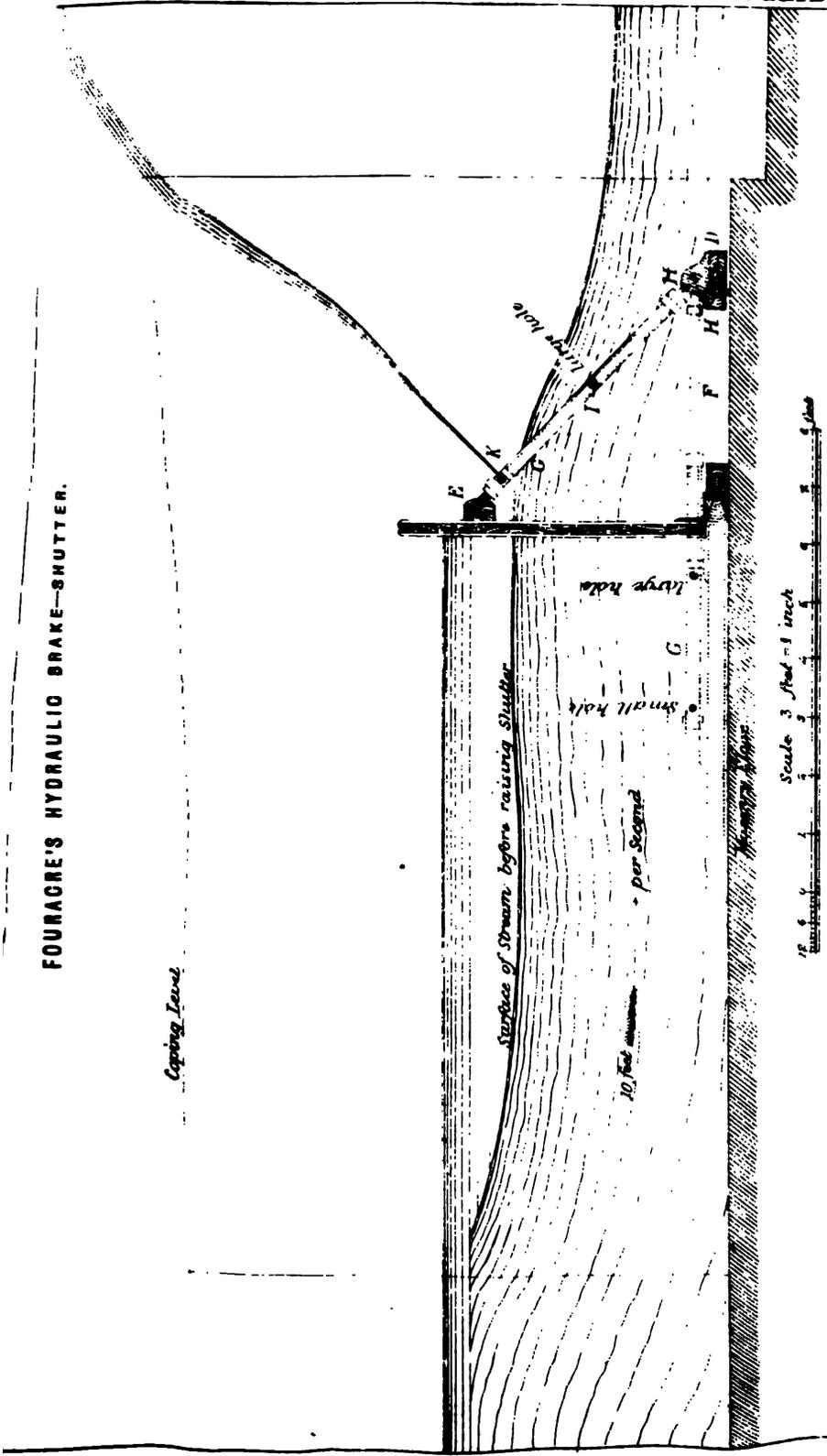

the pier) is fixed to retain the shutter in a horizontal position, until it is required to be lifted.

The down-stream shutter B, is the ordinary single tumbler shutter designed by Mr. Fouracres and now in use on the Cossye anicut at Panchkoorah. This shutter is 20 feet 7 inches long, and 9 feet 9 inches high, fitting between the two piers without any recess; on the front side of this shutter are seven tension bars M, which are hinged in cast-iron sockets N and O. The shutter oscillates about the centre of the pin at N., and the tension rod M. about the centre of that at O., so that when the shutter falls down-stream the lower part slides along the floor towards O., and finally sinks into the horizontal position shown by dotted lines in the drawing.

The socket N is attached to the shutter some few inches below the centre of pressure when the water is at its highest, so that when the level is such as to raise the centre of pressure sufficiently above the centre of the socket N, and to overcome the friction of the lower edge of the shutter on the floor, the shutter falls into the horizontal position and the water is free to pass through.

A catch P, at each end of the shutter retains it against any head that may accumulate on the up-stream side, and a crank catch U, fitted on its lower edge will counteract any strain which may be thrown upon the shutter by an alteration of the centre of pressure caused by an accumulation of water on the down-stream side. Two vertical bars Q with a catch at their lower end, keep the shutter from floating and shifting about when water is rushing through the sluices. Pieces of kentledge R, are also fastened to the front of the shutter as shown on the drawing, to keep it steady and to prevent it from being raised by the water until catch Q is in gear. The clutch U, is simply a bar of square iron hinged to the lower edge of the shutter and slightly cranked near the centre; when the shutter is raised, the crank or joggle in the bar falls into the casting W, which is provided with a lug to catch it immediately below the crank clutch and sliding in the same casting is a longitudinal bar X, which can be moved backwards and forwards in bearings provided for it, by means of the long lever Y, fixed at the end of the pier; on the top of this bar are small inclined planes or wedge-shaped protuberances, which, when the bar is moved horizontally, force the clutch bar U, out of the catch or lug on the castings W, and the shutter is then free to fall.

In each of the shutters is a small sluice S, which can be opened by hand at will.

In front of the up-stream shutter is a groove T, cut from top to bottom of the pier, into which logs of timber can be dropped any time when repairs are necessary to the shutters, or in case of accident preventing them from being lifted.

During the whole of the dry season, in order to retain the water in the weir pool, it will be most convenient to leave the up-stream shutter, which will be quite water-tight, standing: when the freshes are expected and it becomes necessary to make arrangements for opening the sluices, the back shutter is raised by men who can with little difficulty lift it from behind; or if it be thought necessary to employ a less number of men than would be required to lift it by hand, a double purchase tackle can be easily rigged in eyebolts fixed to the upper and lower shutters for the purpose. When the back shutter is up, the top catches P, and the lower clutch U, are fastened; the small sluice S, in the front shutter is then opened and the space between is filled with water; the pressure of the water being now borne by the lower shutter, the upper one can with ease be lowered and fastened by the catch L, in a horizontal position. A day or two before the freshes are expected, the catches P, and U, of the back shutter are unfastened; so that when the freshes come down and the water in the river rises to the top of the back shutter, it will upset of its own accord, leaving the vents clear.

At the end of the floods or at any time when it is required to raise the shutter, it is only necessary to unfasten the catches L. of the front shutter which will float up of itself until it encounters the impulse of the stream, which will in a very short time raise it into its vertical position; the shock always so disastrous with the French shutters in use in the other under-sluices is entirely removed by the resisting action of the hydraulic brake struts.

Whenever it is necessary to raise or lower the shutter, the above operation must of course be repeated.

The advantages of this system over the old French plan are—

- I.—That the heavy wooden beams from end to end of the sluices, the ponderous cast-iron shoes required for the back stays and wrought-iron hinges, the front and rear disengaging clutch bars, and the large holding-down bolts, are entirely dispensed with.

- II.—That the front shutter being the one that retains the water during eight months of the year, all the working parts can be easily got at for repair, painting, &c.
- III.—That the piers being so close to one another, timber beams can at any time be dropped into the front groove for the purpose of effecting repairs.

C. F.

Memorandum of experiments conducted at Midnapore on the hydraulic brake shutter, the invention of C. FOURACRES, Esq., Executive Engineer of the Dehree Workshop Division, proposed to be used in the Under-slucices of the Soane Anicut.

These experiments were made on the 29th and 30th April, 1872, in the under-slucices of the weir across the Cossye at Midnapore, and conducted by a Committee composed of—

Mr.	J. Kimber, Executive Engineer,	Cossye Division.
„	C. Fouracres, „	Dehree Workshop Division.
„	J. H. Apjohn, Assistant „	Cossye Division.
assisted by	„	A. Snedon, Sub-Engineer.

The place of experiment was a vent of 5 feet wide of the full height of the pond caused by the weir; the longitudinal or up and down-stream section is given in the accompanying *Plate (IV)*.

The depth of water on the up-stream side of the vent was 5 feet, and on the down-stream nothing.

The vent is closed at the up-stream entrance by a large shutter, which is capable of being lifted wholly out of its grooves making all clear; in this sluice and near its bottom edge is a small sluice giving an opening of 2 feet square.

By rectangular holes in the walls of the vent close to the floor, means are afforded for fixing temporary timber sills for experimental purposes.

The shutter to be experimented on was $5\frac{1}{2}$ feet high, with a clearance of about 1 inch on each side and was hinged in the first instance by two, and afterwards by three, iron hinges to a sill timber previously fixed for the purpose; the shutter falls up-stream wards. To the back of the shutter is hinged at about 18 inches below its upper edge a piece of boiler tube $2\frac{1}{2}$ inches diameter, and to a sill timber $4\frac{1}{2}$ feet in rear of the shutter is hinged a plunger which works in the tube. The plunger and tube together

form a rigid strut and support to the shutter when in an upright position. The fore end of the plunger is furnished with a leather gland like that of a pump bucket which permits of easy withdrawal of the plunger, but exposure to internal pressure, which expansion prevents any escape of water at the sides of the plunger; the greater the pressure in feet, the tighter the apparatus is in this direction. At about 15 inches in rear of the plunger head is made an enlargement easily fitting the tube merely to serve as a guide to keep the plunger and tube in a true line when in action. When the shutter is prone, the plunger and tube hereafter called the brake, is in its most extended condition, and when the shutter is up, it is in its most contracted. In the most extended condition the brake is supposed to be always under water, and by means of a hole in the tube, about $\frac{3}{8}$ -inch diameter, just in front of the plunger the tube becomes filled with water. Another, but very small hole, pierced in the top of the tube is for the exit of the water, while the shutter is rising, and the brake in action.

The action of the shutter.—The shutter being in its prone position with the stream running over, it has by its buoyancy first, and then by the action of the stream, a tendency to rise or turn about its hinges, and but for some contrivance would fly back with very great violence. This violence may be in some measure appreciated when it is stated that the chains of the same size of shutter forming the front set of the double French system in the Midnapore under-sluices are frequently broken, and these chains are $\frac{7}{8}$ -inch stud-cables, tested to a strain of 10 tons, and there are two of these chains to each shutter. The shutter in rising presses upon the tube which closes slowly upon the plunger, while the water is forced out of the smaller hole mentioned. *The absorption of the force required to expel the water in front of the plunger of large diameter through the smaller orifice constitutes the brake action.* The greater the disproportion between the diameter of the tube or plunger and that of this hole, the slower the process. At first starting from its prone position, a slight advantage is given to the rising tendency of the shutter by the relief given to the tube by the larger hole near the plunger, until the moment that the plunger passes it. This hole permits of a very short travel by the plunger until it is covered, as it would not do for the shutter to gain much way without the full check offered by the brake.

On the 29th April.—1st experiment was with the small vent 2 feet square only open which yielded a stream of water 18 inches deep on the

BREAK

Scale 5

ELEVATION OF BACK SHUTTER.

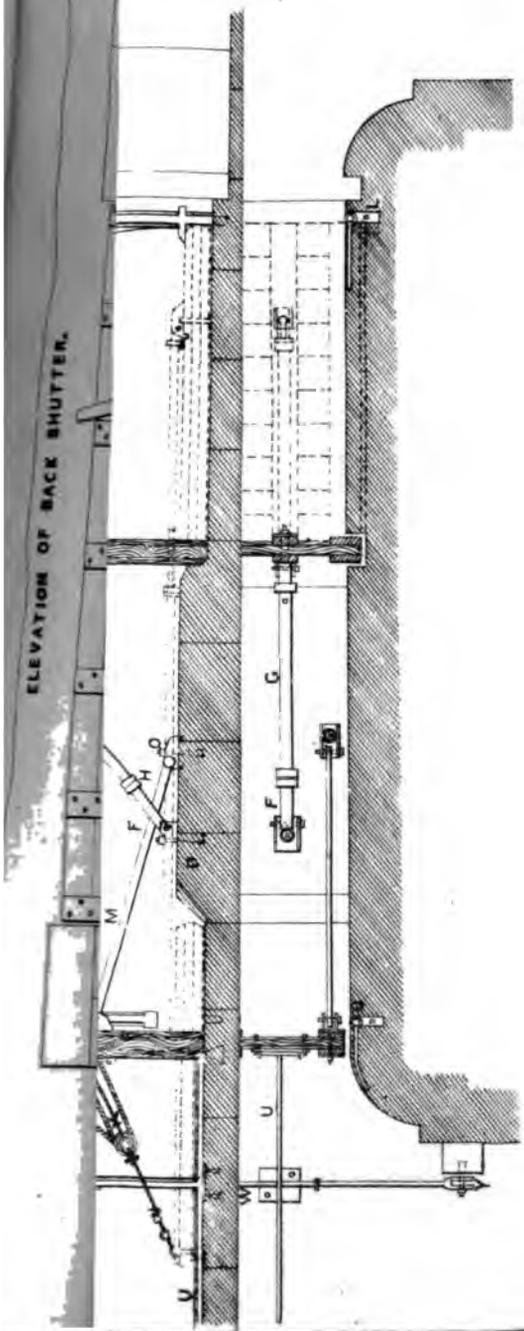

BRAKE 1/4 SIZE.

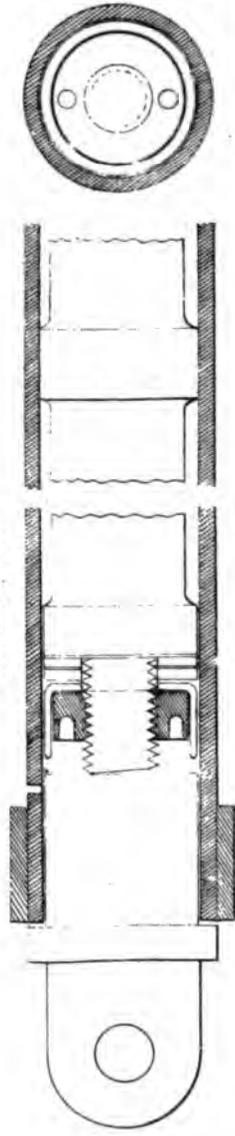



shutter running at a velocity of 10 feet per second as taken by the current meter. The shutter on being released rose in 15 seconds, rising as the head accumulated on it without the slightest shock. The water being shut off the shutter was again laid prone.

2nd experiment.—The whole vent was opened, but on releasing the shutter, the hinges gave way, putting an end to the experiment; and the remainder of the day was occupied in putting on stronger hinges and replacing the plunger rod in part by iron of larger diameter.

On the 30th April everything was re-fixed and the smaller hole in tube enlarged to $\frac{1}{4}$ -inch.

1st experiment.—With the small shutter of vent opened, and other conditions the same as in the experiment of previous day, the shutter rose in less than 10 seconds without any shock whatever. This was repeated half a dozen times with the same result.

2nd experiment.—The vent was fully opened; the stream ran $3\frac{1}{2}$ feet deep with a velocity of 10 feet per second over the shutter as taken by the current meter. The shutter on being released rose in less than 5 seconds without the slightest shock or hitch of any description. The actual head of water in the pond above the vent was 5 feet.

It is to be mentioned that the shutter was fixed at 6 feet from the downstream end of the vent where there is a clear drop of 9 inches to the rear apron of the under-sluices; where again there were only a few inches of water at the time of the experiments.

It will be observed that the shutter has been exposed to conditions which are never likely to occur in actual practice. In practice there would always be a certain depth of water in the rear to relieve the accumulating head in front.

The conclusions are, that the application of the principle of the hydraulic buffer (to be here called the hydraulic brake) has been perfectly successful. It is probable that some improvements may be found in the replacing of the plunger by a less perishable material, but this is a comparatively unimportant matter of detail. The principle can be applied to a shutter of any dimensions consistent with proper proportions of strength and due attention to the proportion between the diameter of the plunger and that of the smaller orifice of discharge from the tube.

It appears that any appreciable period short of instantaneous action is sufficient to prevent any shock.

J. K.

No. LXVII.

EASTERN GANGES CANAL.[*Vide* Plates V. and VI.]

(Compiled by Editor).

THE tract of country between the Ganges and Ramgunga Rivers, forming Western Rohilkund, and comprising the districts of Bijnour, Moradabad, and Budaon, having suffered severely from droughts, projects for irrigating this 'doab' from both the rivers were taken in hand under the general direction of Mr. J. L. Parker, C.E., Superintending Engineer. In 1869, the earthwork (in part) of 18 miles of the projected canal was executed as a "famine relief work;" and in connection with the submission of the Estimates for this Earthwork the subjects of the proposed volume, and system of distribution of water supply of the canal, (designated the Eastern Ganges Canal,) were discussed in the correspondence between the Supreme and North-Western Provinces Government.

All the discussions on these, and collateral, subjects are very interesting to the Hydraulic Engineer, but they cannot be reproduced in this journal *in extenso*; the following extracts however will sufficiently exhibit the several views held by different Engineers, and the arguments adduced in support of these views: and will, it is hoped, be found well worth personal and careful consideration.

The appended Map (*Plate V.*), shows the general, proposed, direction and arrangement of the main lines, and larger distributaries, with sufficient accuracy to illustrate the references in these extracts of correspondence. It is reduced from a map originally compiled by Mr. Parker, when surveying for a canal from the Ramgunga in 1856. The map does not however show the "perennial channels" on the right and left



on the main canal, the proposal for which forms the principal subject of discussion in the correspondence. These may be imagined to run more or less parallel with the main canal below the 30th mile, and with the Sumbhal and Amroha Branches, at the distance of a mile or two on both right and left sides.

It will be understood that all reference to many letters, reports, &c., is entirely omitted, and that some of the subjects discussed in the papers under consideration are also ignored *in toto* in these extracts; which deal only with the arguments, &c., bearing on the questions of "volume, and system of distribution, of water supply" in the proposed canal.

Chief Engineer (Irrigation), N. W. Provinces, 9th December, 1869.

The following is a Statement of the Scope and Design of the Canal. It has been determined by the Government of India that a volume of water of not less than 1,000 cubic feet a second shall be contributed from the Ganges for the irrigation of this tract in the rubbee season, because the Ramgunga is unable to supply the full demand, and because the want is shown by experience of rain-fall in the last two years to be even more urgent in Bijnour, Moradabad, and Budaon, than in the Districts on the right bank of the Ganges.

The total area irrigable, then, from the Eastern Ganges Canal alone, being shown to be 3,152 square miles (or 2,016,000 acres) in extent, half (or 1,008,000) must be considered irrigable in rubbee and half in khureef. The duty in rubbee looked for by Government of India is 200 acres per cubic foot, and the proportion which it is desired to irrigate everywhere is one-fourth of the area under cultivation; therefore $\frac{1,008,000}{4 \times 200} = 1,260$ cubic feet a second of discharge, will be requisite to fulfil the conditions; and this amount we must be permitted to take from the rubbee supply of the Ganges when the right bank is getting its 6,500.

But for the khureef our supply is happily larger. The Ganges rose this year at Asufghur on 17th May to 13,346 cubic feet: it rapidly increased to three times that amount, and early in October the volume was over 65,000 cubic feet.

So there is as much as we want available for the whole season of rice irrigation, which may be taken from 25th May to 30th September. It would be unwise to neglect this benefit in a country peculiarly adapted to

the cultivation of rice, which already is the favorite staple and chief article of food in Bijour; it is therefore proposed to provide for a supply of 4,500 cubic feet a second in the khureef. The Government of India proposes 100 acres as the khureef duty of a cubic foot of water; but we cannot attain those results when rain-fall is so light as in the districts under consideration, and 75 acres per cubic foot is quite the outside duty which is possible in this case, supposing an average variety of khureef produce to be grown. To irrigate one-fourth of the area at this rate, would require 3,360 cubic feet; but we have taken a larger quantity, first, because, if a larger proportion of rice is actually grown, the duty, as our experience shows, will be much less than 75 acres per cubic foot, and further, because, on the design adopted, the enlargement of volume only affects the cost of the canal in respect of earthwork, and of the masonry works on the first 30 miles; as below that point, the main canal, as hereafter explained, is a khureef canal only, with very few masonry bridges.

The design, then, submitted for sanction is for a canal carrying:—

Rabbee.	1,250 cubic feet.
Khureef.	4,500 "

The water is worth:—

	c. ft.	Duty.	Rs.	Water-charge.
				Rs.
Rabbee.	1,250	x 200	x 1-00	= 4,75,000
Khureef.	4,500	x 75	x 2-25	= 7,59,375
Add 5 per cent. miscellaneous.				= 38,750
Total net income.				12,73,125

The whole direct income is reckoned so because there is a further land-tax rate deductible of not less than one rupee an acre, which more than provides for working expenses.

The estimated cost of project is Rs. 77,52,500, which does not include mill-bridges, or punctations, or other miscellaneous expenses, is calculated. I would take 20 miles for railway and 15 miles for revenue, which would yield 14 per cent. under the "factor of safety" adopted by Government of India.

Showing that justified the project, it remains to explain it.

It is proposed to establish the head at "Shampura," where the head-works of the Ganges, broken by islands and several channels, admit of supply being sent into the canal without expensive works. This is not the case at any point lower down, and does not require head-works.

whilst higher up, there is no place where the climate allows people to remain all the year, as they do at Shampore, to the number, it is said, of about 100.

From a head so placed, the water, after passing through one mile over 60 feet of digging, three miles over 50 feet, and one over 40, comes to the surface of the ground about the 21st mile, and commands the whole of the irrigable area of the country. At the 30th mile the difficulties are at an end.

In this distance, five hill torrents are encountered, none of considerable length of course, or very large volume, and all running *on boulder beds*. It is proposed to divert the first two away from the canal, to pass the two next over, and the fifth under the canal. With boulder foundations and boulders to furnish stone and lime, these works will not be expensive.

At the 30th mile the canal hitherto undivided will break into three—

1. The left perennial channel carrying	992 cubic feet.
2. The right perennial channel carrying	235 "
3. The main (khureef) canal carrying	2,946 "

It will be seen that the capacity of 1 and 2 equals the whole *rubbee volume*; no water, therefore, will pass down the main canal below the 30th mile, excepting during khureef.

The *rubbee* irrigation will be carried out from the perennial branches with the help of minor *Rajbhas*, one for each minor "Doab," as shown in map (*Plate V.*) accompanying. And the khureef irrigation will be afforded by the same channels; with this difference only, that as in khureef the expenditure of water per hundred acres, and therefore per mile of channel, is more than double the expenditure in *rubbee*, it is requisite to re-inforce the perennial channels from time to time by feeders taken from the main channel, which during khureef will be running full. The main channel is thus a large supply channel only, dry during the *rubbee* season.

It is proposed to have no bridges on the main canal below the 30th mile, save where it is traversed by district or imperial roads, and to make all the works of an inexpensive character: paved inclines in dry season, and ferry boats in rainy months will accommodate the scanty traffic on purely village roads.

The perennial and minor channels will have a fair proportion of bridges, and be finished canals.

It is proposed to have no navigation from the heads to the crossing of the Nujeebabad-Bijnour road at about the 29th mile; as the fall being

rapid, many locks would be requisite, and little else could enter the Canal but timber, which may find its way down the Ganges.

And from the 30th mile downwards, it is proposed to have only one navigable channel, viz., the Chundowsee perennial line, which will connect Nugeenah, Nujeebabad, Bijnour, and Amroha, with that important mart. As there is an average fall of two feet per mile all down the country, the saving of large numbers of locks on other channels will be a very considerable item.

Navigable junctions from Chundowsee to Moradabad, and Chundowsee to Canal Dam at Rajghat, are contemplated but not yet investigated. Below Chundowsee, on the line of perennial canal, there will not be sufficient water for navigation.

Government of India, P. W. Department, (Irrigation,) 18th March, 1870.

The Chief Engineer now proposes to fix the volume of the canal at 1,250 cubic feet per second in the cold weather, and 4,500 cubic feet in the rains. He has calculated the supply of water required, by taking one-fourth the whole actual area commanded by the canal as the proper proportion to which the means of irrigation should be given, and by assuming that the area of khureef and rubbee crops irrigated should be nearly equal. As the whole area is somewhat over two millions of acres (2,016,000), this gives 252,000 acres as the computed area of each crop to be irrigated; and, allowing 200 acres per cubic foot for the rubbee, and 75 acres for the khureef, the discharge required in the two seasons, namely, 1,260 and 3,360 cubic feet per second is arrived at. But as it is expected that a large proportion of the khureef crops irrigated will be rice, it is considered advisable to reckon on a lower duty than the above from the water, or what is the same thing, to allow a larger supply for the given area. The quantity considered suitable by the Chief Engineer is 4,500 cubic feet, which gives 56 acres per cubic foot.

The anticipated returns are—

Rubbee,	1,250 × 200 × 1·9	= 4,75,000
Khureef,	4,500 × 75 × 2·25	= 7,59,375
Miscellaneous, 98,750
		<u>13,33,125</u>

If 56 acres only were irrigated by each cubic foot of the khureef supply, it may be concluded that a proportionally higher water-rate would be

levied, and that the gross return would not be affected. It is estimated that the additional landlord rate, which would be levied from the irrigated lands, would suffice to cover the cost of maintenance. The above would, therefore, represent the ultimate net income to be obtained from the canal.

The estimate of cost, as now submitted, amounts to Rs. 77,82,856, (£778,285), not including outlay on mill-houses and plantations, nor apparently on navigation works, from which the additional income of nearly one lakh of rupees is to be derived. Allowing for these omissions apparently, Rs. 90,00,000 (£900,000) are taken as the total probable cost of the works.

There does not appear to be any provision for disposing of local drainage below the 30th mile of the main channel, though it is certain that a considerable outlay would have to be incurred for this purpose if the proposed designs were adopted, since all the drainage and surplus irrigation water from the fields between the main lines and the proposed east and west rubbee canals, would have to be passed across the latter. Allowing for those omissions it may not be unreasonable to suppose that the cost of the works might reach £1,000,000. The net income would be 18½ per cent. on the capital, which in a general way is quite satisfactory.

But His Excellency the Governor-General in Council is not satisfied that the proposed method of dealing with the distribution, by means of separate channels for the rubbee or permanent supply, and the khureef or intermittent supply is the best possible. Apart from the objection above-mentioned, which is a serious one, and calls for special explanation as to the proposed manner of dealing with the intercepted drainage of the tract between the canals, the Governor-General in Council doubts the expediency of the general system proposed. At all events no attempt has been made to prove that it is the most advantageous, and in so important a matter His Excellency the Governor-General in Council cannot accept recommendations of the local Engineers which are not supported by any argument or proof.

What they suggest is to provide a special series of channels able to carry about 1,250 cubic feet per second, and another set to carry 3,000 cubic feet.

From the head to the 30th mile there is to be a single channel, and no remark is called for. At this point the canal divides into three. The

centre line is to carry the khureef supply only, 2,946 cubic feet, the side channels 285 cubic feet and 992 cubic feet, respectively, or together 1,227 cubic feet, which is the rubbee or permanent supply. The differences between the above and the full volumes 1,250 and 4,500 cubic feet, are to be used above the 80th mile.

Now, it seems to His Excellency the Governor-General in Council that a channel that will carry 1,227 cubic feet may quite easily, and with comparatively small extra expense, be made to carry double that volume, say 2,500 cubic feet per second, so that the supplementary channel need only be made to carry 1,700 cubic feet, instead of 2,900 cubic feet. A little addition to the rubbee channel would apparently admit of its carrying the whole of the supply proposed to be put into the khureef canal, say 3,000 cubic feet, leaving 1,500 only for the supplementary line.

It appears to His Excellency in Council that if this course were followed, the canal could be constructed in the ordinary way on the proper water-shed of the country, the permanent canal taking the line proposed for the khureef canal. Thus all interference with the natural drainage would be avoided, which the Governor-General in Council considers to be of the most essential importance.

The supplementary khureef supply could be arranged hereafter, perhaps to some extent on the plan now proposed for the rubbee supply. But His Excellency in Council is strongly inclined to have the works carried out, in the first instance, on the basis of a single line of canal to carry 1,250 cubic feet per second as a permanent supply, giving it as much additional capacity as can be conveniently and economically arranged, and leaving the additional khureef supply, in excess of the quantity that can be carried by the main canal, to be dealt with separately hereafter.

Various ways of doing this might be suggested. One, which seems quite feasible, is to turn the extra supply into the Ban or Gangan, and let it find its own way down the country, passing it into some of the other drainages and having suitable weirs on those drainage lines to admit of its being taken out again at convenient places for irrigation. It is probable that all that is needed could be done in some such way without any interference with the surface drainage. It is understood that the rivers mentioned are not in deep beds, at least as far down as Moračabad, and would, it is believed, be quite manageable in the way suggested.

On the whole, unless it can be proved that a very distinct advantage

would be gained by the use of the double set of channels, His Excellency in Council will prefer the adoption of the more common plan of distribution of the water, which will certainly be under more complete command, without risk of injury to the country by obstructing the drainage,—a risk which in the tract in question seems to be unusually great.

I am further to request that, on the re-submission of the estimates with the emendations now suggested, information may be furnished as to the general condition of the drainage of the districts to be influenced by the Eastern Ganges Canal; and that it may be shown that the effect of the canal water upon it has been fully considered and provided for to a suitable extent in the estimates.

Chief Engineer (Irrigation), N. W. Provinces, 16th July, 1870.

Capacity of Canal System.—A maximum monsoon supply of 4,500 cubic feet was, and is yet, recommended, because—

1. It is easily available.
2. Because if much rice is grown, as is in every way probable, the duty obtained per foot of water will in this region of sand and light loam be so much less than the standard of the Government of India as to employ the greater quantity proposed, even though the proportion of land irrigable every year be estimated at one-fourth only of the whole culturable area.

The Government of India appears to consider the duty which the monsoon supply of water would render under these conditions, viz., 56 acres per foot, to be too little, and directs the adoption of 3,000 cubic feet as the limit, giving a duty of 84 acres per foot.

On three additional considerations I would earnestly recommend that the volume of water originally proposed be not diminished.

First.—That the assignment of one-fourth of cultivated or culturable area as the limit of yearly irrigation, is an estimate of the amount requisite to save a country from famine; but it is quite fallacious as an indication of the wants of the people. On the Ganges Canal there never yet has been a sufficiency of water anywhere to meet all demands; but the following figures, relating to the Eastern Jumna Canal, where water is frather more abundant, (which are extracted from the Census Report of North-Western Provinces as regards areas, and from the Canal Revenue

Report as regards areas irrigated in 1868-69,) shows what people will irrigate when they get a chance:—

Pergunnahs.	AREA IN ACRES.		Per cent. of Canal irrigation to Cultivation.
	Cultivated.	Canal-irrigated.	
Saharunpore,	58,240	33,732	57 per cent.
Rampore,	58,880	42,904	72 "
Chamlee,	45,440	10,680	23 "
Kandla,	49,920	25,857	53 "
Chuprowlee,	37,120	17,206	46 "
Barote,	39,040	27,058	69 "
Baghput,	96,640	27,238	28 "

N.B.—It is only in Pergunnah Rampore that rice is the staple of khureef cultivation. Sugar and cotton are the chief produce of other pergunnahs. The Bijnour, Moradabad, and Budaon Districts, traversed by Eastern Ganges Canal, grow rice and sugar already, and will grow indigo, the people say, when they get water.

In certain pergunnahs in which well-irrigation is most largely and successfully practised, 80 per cent. of cultivated land is irrigated annually. There seems to be no good reason why canal-irrigation should not attain the same development when water is abundant, and then what shall we do if the masonry works of the canal, for which 4,500 cubic feet a second is easily available, have limited supply to 3,000 cubic feet?

Second.—That the loss of volume from percolation on the Ganges Canal appears at this moment to be not less than 30 per cent. on discharge; that canal passes through but a few miles of *bhoor* land, which on the Eastern Ganges is the staple.

The oversight of this point was an omission in the first report, which I am most anxious to rectify, as it is a consideration of the saddest importance. This reduction would make available supply 3,150, which agrees practically with the Government of India limit. The Ganges Canal has now been sixteen years at work, without the leaks which so impoverish it being discovered and staunches either naturally or artificially. No doubt percolation will diminish in process of time, and in that period we may fairly reckon that a demand will arise for Eastern Ganges Canal water, which will fully tax 4,500 cubic feet.

Thirdly.—A flaw has been found in the scheme for making the canal from the Ramgunga independent of the Eastern Ganges Canal. Rising

in the outer **Himalayan Ranges**, and receiving no snow water, the monsoon volume of the **Ramgunga** does not swell until local rains fall (or not), some time between **20th June** and the **18th August**, too late to assist the preparation and sowing of indigo and rice crops, and useless, of course, for the growth of sugar.

It will, therefore, be the cheapest plan to give the **Ramgunga Canal** above its crossing of the **Gangan** a capacity regulated by the available rubbee supply, which, as before proposed, will be applied to the whole length of the canal, a requirement which it can fairly meet. The upper part of this canal, down to the **Gangan**, filled from the **Ramgunga**, will carry khureef supply for that length only; the lower section, from the **Gangan** downwards, must be supplied by a channel from the **Amroha Branch** of the **Eastern Ganges Canal**, which can be carried at the requisite level parallel to the **Moradabad road**. This will abstract 700 cubic feet of khureef supply from the main canals.

It may be thought that too much has been proved, and that 4,500 cubic feet now appears to be too small a quantity. I must admit it is so, but the **Ganges gauge** returns at **Asufnuggur** show it as much as we can depend upon getting in time for indigo and rice sowing: and the volume obtainable for sowing operations is enough for further cultivation. Therefore, I would limit the capacity of canal to 4,500 cubic feet as designed.

Mr. Parker arrives at the same recommendation of 4,500 cubic feet, by considering that one-third of the cultivated area requires water annually.

Distribution.—His Excellency was not satisfied that the proposed method of dealing with the distribution, by means of separate channels for the rubbee or permanent supply and for the khureef or intermittent supply is the best possible, and it is remarked that whilst the **Local Engineers** do not support their recommendations by argument or proof, the scheme is liable to objection as causing interception of drainage, and His Excellency is strongly inclined to have the works carried out in the first instance on the basis of a single line of canal to carry 1,250 cubic feet as a permanent supply, with as much additional capacity as can be conveniently and economically arranged, leaving the balance of khureef supply to be dealt with separately hereafter.

Engineers are agreed that the monsoon supply of a canal in the **North-Western Provinces** cannot conveniently be much more than double the

dry-weather supply. Such a canal, therefore, as is here proposed by the Government of India, would carry 1,250 and 2,500 cubic feet in the several seasons. This plan of distribution, it is said, will bring the water of the canal under more complete command than that proposed by the North-Western Provinces Government.

It is observed that a little addition to the rubbee canals as designed to carry severally (now) 710 cubic feet and 235 feet (not 1,227 cubic feet collectively) would enable them to carry 3,000 cubic feet, leaving 1,500 only for a supplementary line; but whereas the bed of the 710 cubic feet rubbee channel into which only 5 feet depth of water enters at natural flow, is but 43 feet wide; the khureef supply of 3,000, though running 9 feet deep, requires a bed 105 feet wide at bottom. The latter is a canal, the former are but rajbuhas. It does not appear possible to accommodate such different volumes in the same bed; the rubbee supply in the larger bed would be but a foot deep, and would very soon be lost by percolation.

It is held, I believe, by some authorities that the right system in such a case is to dam up the rubbee water in the large channel until it attains a depth approaching that of khureef supply, and of course commands all irrigation outlets, and when the tract thus commanded is watered, to remove the dam lower down, and thus carry a full supply step by step down the canal. This may be practicable enough in deltaic regions, where there is practically no slope, and the lowering of a gate 6 feet deep raises the depth of water in a canal to 6 feet for 40 miles back; but in the project we are dealing with, the proposed slope of bed averages upwards of 2 feet a mile, so that water could only be raised from 1 to 6 feet in depth by having a stop dam at every two and a half miles, or practically just below each irrigation outlet. Obviously a canal 270 miles long cannot be thus dealt with, the crops would wither before their turn for another watering came round. Moreover, the rubbee canal, designed to carry 710 cubic feet when full, costs in Northern Division an average of Rs. 1,954 a mile: the khureef canal discharging 3,000 cubic feet at mile 29, costs from that point to the limit of Northern Division but Rs. 2,545 a mile, showing how cheap is the cost of the unbridged supply canal in comparison to the finished expense canal, even though the latter will be very cheaply constructed. If the large canal were made perennial and the small intermittent, the comparative cost would be very different.

Mr. Parker puts this part of the case very clearly as follows:—

"It was necessary in projecting the Eastern Ganges Canal to maintain a constant head (we had only one-fourth of the khureef supply during rubbee) and to economize it, in order to let the water pervade all the irrigation lines as quickly as possible, and lose as little as possible by absorption and evaporation, especially by the former, in the many sandy tracts the canal passes through.

"All this is done by the system adopted. The constant head is maintained at the first weir dam at the 29th mile. The rajbuhas are made to carry the whole rubbee supply. This is sent down the various lines at a much greater velocity than it could be sent down the main canal, with a greater depth than could be maintained in the canal, and in the most direct way, instead of indirectly, as it would be by going down the canal, and thence by feeders into the irrigating lines. The results are these:—Irrigation is more quickly effected, absorption and evaporation reduced to a minimum; growth of weeds and water-grasses, which would occur if a supply of small depth went down the canal at a low velocity, prevented; much repair and maintenance expenditure avoided, and what is necessary, rendered easily applicable."

Mr Parker also urges reasonable objection to the proposal of throwing the surplus khureef supply into the Ban or Gangan, or other drainage lines as follows:—

"With regard to the East Rohilcund Canals, the system has been to take possession of a nuddee in which there is constantly some water, to dam this up at intervals, and to take out irrigating lines from each dam.

"The results are these:—The Rohilcund Canals have been quite a failure from the essential fact that water is taken out from the nuddees which occupy the lowest points of the country, and can only water the adjacent low lying lands, without being able to touch the higher; so completely has the mistake been realised that the whole of the East Rohilcund Canals are now undergoing either revision or remodelling.

Drainage.—Regarding the obstruction to drainage, which is anticipated by the Government of India to result from the mode of construction here-in proposed, the Superintending Engineer observes:—"The chief feature of the Doab we are dealing with is, that it is drained by a system of natural lines between which are very narrow strips of country, as will easily be seen by a reference to the sketch maps accompanying the project. The names of the principal drainage lines beginning at that furthest north,

are—the Rohasan, Peli-ki-Rao, Khatawala Khalia, Jakran, Malin, and Chain Nuddees, all of which are crossed by the canal, and the Ban, the Gangan, and Karula Nuddees in the northern half of the Doab, and the Choya, Sot, or Yarwafadar, and Aril Nuddees in the lower half, between which the canal and irrigating lines will run on the water-sheds. After once passing the first group of nuddees above-mentioned, no further drainage lines require to be crossed. This is a fact of considerable importance, and one to be coupled with that of the narrowness of each strip of country lying between two rivers, and to be remembered when considering the question of drainage in connection with irrigation.

“The main canal and its two branches run on water-sheds and will throw off the drainage towards the irrigating lines next to them. Such drainage will pass under these lines and will be arranged for when more minute surveys of the country have been made. The feeders will intercept the longitudinal drainage of the country, but this can also be passed under the irrigating lines and thence into the nuddees. Provision for this can also be made when the country has been better surveyed. This survey could go on while the canal works are being executed, and estimates from time to time prepared and submitted.

“I believe it will be found that very little drainage work will be required. Besides the favorable feature before described of the Ramgunga Doab, when it is itself traversed in all directions by our irrigating line-feeders and minor rajbhas, and by the innumerable water-courses which the agriculturists themselves must make for irrigating their lands, the surface of the country will be so cut up into small areas, that each area will retain or consume most, if not all, of the rain-fall upon it, and works will not be required for draining it. Much of the country is sandy, and will absorb water to a large extent.”

Detailed surveys will probably show that no system of drainage can advantageously be laid out until irrigation is developed, and that the channels requisite will, from the causes narrated by Superintending Engineer, be very short and minute. There will be no difficulty in making them. The sandy *bhoor* soil traversed by the canal is particularly absorbent and permeable, and it is probable that surplus irrigation water will rapidly pass off into drains judiciously arranged. But it is certain that where springs are not very near the surface, the soil will not readily acknowledge a surplus.

From the 57th to 97th miles on the section of main canal, water is found within 10 feet of the surface. A correspondence occurred between Chief and Superintending Engineer on the question whether this tract would not do better with well than with canal irrigation; but it is found that the water bearing surface affords but a very scanty supply. Wells without lining can easily be sunk in this tract, but if a large demand be made upon them by the use of any machine of more power than the *dhenklee* (an earthen jar worked by the weight of a man acting on a balance beam), they at once give out and fall in. Wells lined with timber or brick fare no better, so that the irrigation resulting from the wells in use, though they are very numerous, is very trifling, and the people are urgent in asking for canal water. Great care will be requisite in dealing with the irrigation of this tract. The first effect of the construction of the canal will be to drain the country; the next, when supply is admitted, to raise the surface of water in the wells and increase their volume: it will probably be necessary to do one of two things, either to drain this part of the country, and introduce canal-irrigation with a sparing hand, or to let well-irrigation go on on the larger scale which will then be practicable, without further aid from the canal than percolation affords. This question must be left to be dealt with when mature. The map shows the drainage will be very easy.

Government of India, P. W. Department, (Irrigation,) 7th March, 1871, did not acquiesce in the conclusion that the system of separate channels for the conveyance of Khureef and Rubbee supply, respectively, satisfactorily overcomes the difficulty of dealing with the two different volumes of water. Other arrangements were suggested: the main feature of which consisted in separating the project into two distinct portions; and providing for the irrigation of the upper portion of the Doab (which is less than one-fourth of the whole area) by a distinct main canal of small dimensions.

The principle of substituting short distribution channels whose khureef capacity would in most instances be suitable for the rubbee supply, (which must, under any circumstances, be distributed by rotation,) was considered to overcome the difficulty of dealing with different volumes of water during the respective seasons of cultivation, and to interfere in the least possible degree with the natural drainage lines; a matter of the greatest importance.

By dividing the irrigation of the Ganges-Ramgunga Doab into two distinct series of channels, the lower portion of the project as submitted would not be affected as far as the main lines are concerned, that is to say, from the Amroha bifurcation to the termini. The alignment of the first 15 miles of the upper channel would probably remain the same, but before actually laying out the channel further investigation would be necessary, of the possibility of reducing the quantity of deep excavation encountered between the 3rd and 7th and 13th and 20th miles of the canal. It was observed that a fall of 15 feet is allowed between the point where the water is proposed to be drawn off from the main stream of the Ganges and the artificial head of the canal, a distance of only $1\frac{1}{2}$ miles: and it was suggested that it would be a more economical plan to take the head of the canal from some point still higher up the river so as to enter on the high land with a moderate cutting of from 15 to 20 feet. It was considered that if this was feasible, it was on every account to be preferred; not only as being more economical, but also as more expeditious, and reducing the necessity for employing a large body of laborers in a very unhealthy part of the country.

Chief Engineer (Irrigation), N. W. Provinces, 26th Oct., 1871, showed that the last proposal—to construct, instead of one continuous canal, two separate canals, with heads at Shampore and near Bijour, respectively, was inexpedient on Engineering and financial grounds. The subject was re-investigated by Mr. Parker, and by Mr. J. W. P. Roberts. C.E., Executive Engineer, and the following extracts from their reports, (with the Chief Engineer's remarks thereon,) show the results of their investigations.

"Mr. Roberts' note, extracted marginally shows that the position of the head of the

"When the survey of the Eastern Ganges Canal was first commenced (in 1868), a line of levels was taken *vid* Bijour to Raolee to test the practicability of taking the water from that point. This idea was abandoned because it was found that such a canal would not water the Bijour District, and as it was always understood that it was a *sine qua non* that that district should be irrigated, we proceeded to try for a head higher up. First Nagul was tried, next Asufgurh, and lastly Shampore. We found that the rise of the river is small up to Nagul,* but

* From Raolee to Nagul, the rise of the river varies from 17 to 2 feet per mile.

that at that point its character completely changes, as there the boulder bed (with its attendant rapid fall and high velocity begins. My Progress Report for December, 1868, gives the result of our trial levels taken for the Bijour line."

Eastern Ganges Canal was very fully considered when the surveys were commenced in 1868-69. After careful review of the various alternatives and examination of the country, I cordially agreed with Mr. Parker in fixing the head of the canal at Shampore.

The new proposal to establish a second head near the junction of the Malin nuddee

with the Ganges has been investigated with great care and fidelity by Mr. Roberts. He

Extract paragraphs 15, 16, and 17 of Mr. Roberts' Report.

A few general remarks on the proposed Raolee Canal. The point of junction of the Malin nuddoe with the Ganges is in many respects a favorable site for a weir, as the khureef bed of the river is narrow and the main stream runs close to the eastern high bank. The bed is, however, composed of very fine sand—so fine that it is difficult and almost dangerous for a man to cross it, as the feet sink.

The khadir through which the canal would pass for many miles is not very favorable, being, like most other parts of the khadir of the Ganges river, composed of very fine sandy soil with a foot or so of alluvial soil on the top. Near Raolee the Ganges water, although not having a high velocity, eats with apparent ease into the khadir land.

The bed of the canal would, as will be seen on reference to the longitudinal section, run for many miles (in fact nearly the whole distance) below the spring level of the country.

Mr. Parker's Reasons (pages 5 and 6 of some Book, (1st Part).

I attain my object from one head instead of two, as is required by the New Scheme.

I utilize a natural weir, and require no artificial one, while the New Scheme requires one, if not two, of the latter.

I take my whole supply from the river, where it has a minimum of silt (an advantage, according to paragraph 5 of Preliminary Observations of Ganges Canal Committee of 1866), while the New Scheme takes its larger volume from a point where the river must have an enormous amount of silt during the season when this larger volume is required to enter the canal.

I do not interfere with the course of the river, which the New Scheme does by establishing one, if not two weirs.

I take my head at the highest possible point in the river, where it has a permanent boulder bed, not liable to change, while the New Scheme takes the head for the larger supply in the khadir which is liable to change at any time—a fact I know, not only from my own experience, but also from its being confirmed by paragraph 9 of "Ganges Canal Committee's Preliminary Remarks."

I carry water from the head only 19 miles without irrigating, while the newly suggested line cannot irrigate till the end of the 36th mile.

Having to withdraw a certain quantity of water from a river, it is cheaper relatively to the discharge to take it from one head than from two.

pore."

With regard to the objection to the want of a proper provision for drainage for the triangular plots into which Mr. Parker's plan of construction would divide the lands lying between the khureef (or supply) and the rubbee (or perennial) canals, a sketch (as per accompanying diagram) was submitted and it was remarked as follows:—

'In the accompanying diagram all canals and water-courses are shown in full lines, and drainage lines (which it will be observed are formed by the boundary ditches of the irrigation channels) in dotted lines. The whole drainage is shown by the arrows to be taken into the various ditches and passed under the rubbee canal at intervals, the accumulated waters shown by larger arrows being finally led into a natural drainage line.

It is not possible to fix the position of the several minor lines until levels of the country have been taken at very close intervals; meanwhile the diagram shows that the drainage can be completely effected. The

establishes that this new scheme, instead of being cheaper by £43,000, as it claimed to be, would cost as nearly as possible 50 per cent., or £418,000, more than the project recommended by the Government, North-Western Provinces, and that it is further subject to the serious objections quoted in the margin, which prove that the amended scheme would be undesirable if it were not financially impracticable. I accordingly see no grounds for altering the original recommendation that the Eastern Ganges Canal should be constructed from one head fixed at Sham-

amount allowed by the Executive Engineer for this purpose, appears reasonable and sufficient.

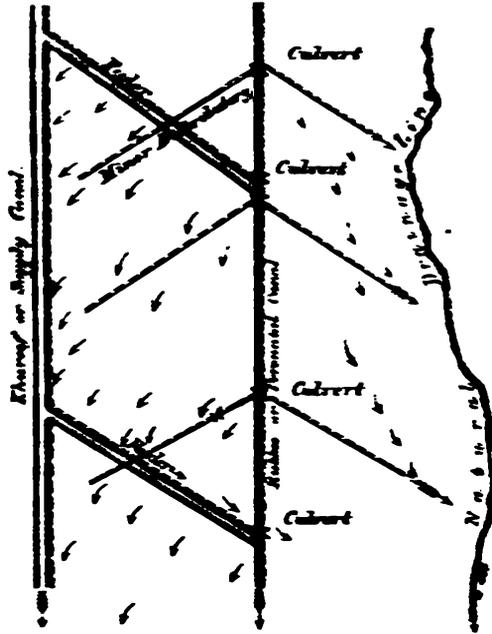

Col. H. A. Brocrouse, R.E., Offg. Chief Engineer, Irrigation Works, B. W. P., the 2nd April, 1872.

Having been called upon to state my opinion on the system of distribution of water proposed for adoption on the Eastern Ganges Canal, I must say that it appears to me to lie open to two grave objections—

1st.—That of affording a needlessly large supply of water during the khureef to districts where the nearness of spring level to the surface of soil calls for the greatest care and circumspection in giving canal water at all during any except years of famine.

2nd.—That of interfering very seriously with the drainage of the country in order to secure this lavish irrigation, thereby aggravating immensely the water-logging of soil and unhealthiness which must inevitably result from it.

The proposal is to carry a large khureef channel down the main watershed of the country traversed by the canal. On either side of this, and running more or less parallel to it, are to flow two perennial channels,

which are said themselves to occupy minor watersheds. The irrigation of the country is to be effected by water-courses from the perennial channels, while feeders taken out from the main khureef channel will supply these perennial lines when the main line is carrying water.

Now, a glance at the following sketch, which gives a general idea of what I conceive to be the physical features of that part of the country, will show how completely such a system of distribution will interfere with and choke up the minor drainage lines:—

If it be argued that my sketch gives an exaggerated view of the amount of obstruction to drainage that will be caused by the proposed system of

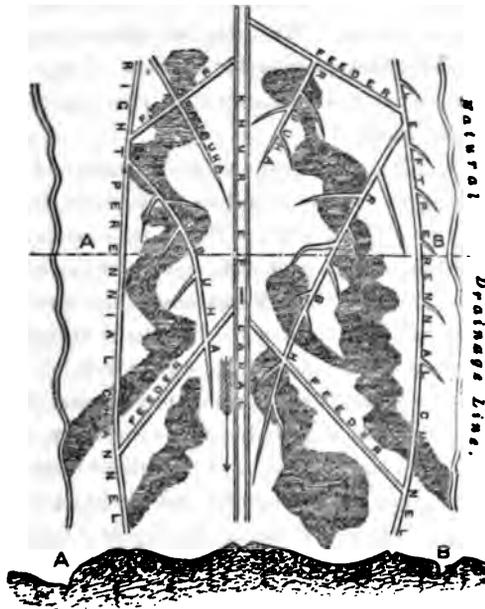

distribution, I reply that there are no reliable data available to refute it. It is allowed that the minor drainage lines of the country have not yet been carefully surveyed, and my own opinion is that they will, in many instances, be found even more complicated and difficult to deal with than I have pictured them.

Mr. Parker, the Superintending Engineer, who initiated this project, assures me that a personal knowledge of the country enables him to state that these minor drainage lines are not of any importance; but it must be

amount allowed by the Executive Engineer for this purpose, appears reasonable and sufficient.'

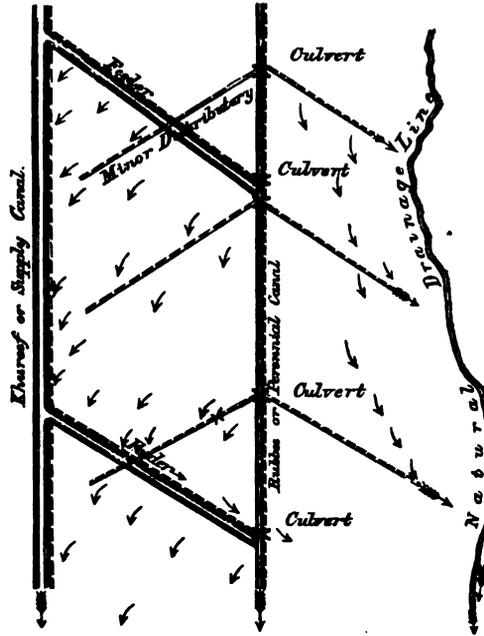

Col. H. A. Brownlow, R.E., Offg. Chief Engineer, Irrigation Works, N. W. P., the 2nd April, 1872.

Having been called upon to state my opinion on the system of distribution of water proposed for adoption on the Eastern Ganges Canal, I must say that it appears to me to lie open to two grave objections—

1st.—That of affording a needlessly large supply of water during the khureef to districts where the nearness of spring level to the surface of soil calls for the greatest care and circumspection in giving canal water at all during any except years of famine.

2nd.—That of interfering very seriously with the drainage of the country in order to secure this lavish irrigation, thereby aggravating immensely the water-logging of soil and unhealthiness which must inevitably result from it.

The proposal is to carry a large khureef channel down the main watershed of the country traversed by the canal. On either side of this, and running more or less parallel to it, are to flow two perennial channels,

which are said themselves to occupy minor watersheds. The irrigation of the country is to be effected by water-courses from the perennial channels, while feeders taken out from the main khureef channel will supply these perennial lines when the main line is carrying water.

Now, a glance at the following sketch, which gives a general idea of what I conceive to be the physical features of that part of the country, will show how completely such a system of distribution will interfere with and choke up the minor drainage lines:—

If it be argued that my sketch gives an exaggerated view of the amount of obstruction to drainage that will be caused by the proposed system of

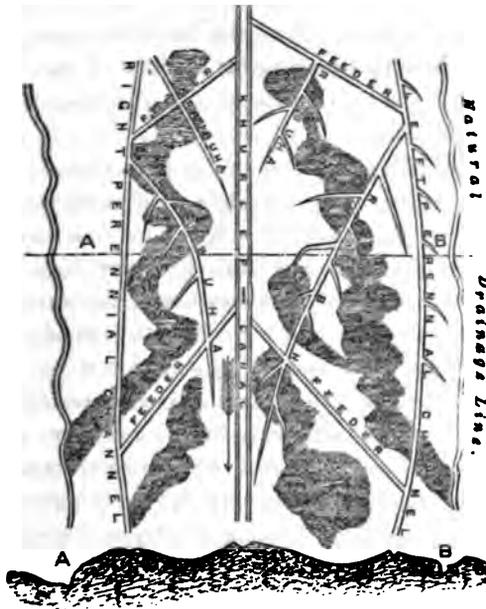

distribution, I reply that there are no reliable data available to refute it. It is allowed that the minor drainage lines of the country have not yet been carefully surveyed, and my own opinion is that they will, in many instances, be found even more complicated and difficult to deal with than I have pictured them.

Mr. Parker, the Superintending Engineer, who initiated this project, assures me that a personal knowledge of the country enables him to state that these minor drainage lines are not of any importance; but it must be

remembered that the question is not what is their condition *now*, but what it will be after the canal has been running for ten years.

The spring level of the country is already only 10 feet below the surface between the 57th and 97th miles of the main canal. The annual rain-fall in this tract during ordinary years is about 30 inches, and the effect of the fully developed irrigation from the proposed canals will be to throw an additional 13 inches of water over the whole area, thereby making, as it were, the present exceptional rain-fall of unusually wet years the rule.

The irrigation from the Ganges Canal, which is not conducted on anything like so profuse a scale as that proposed for these canals, has already raised the spring level as much as 20 feet in many of the tracts where rice is most cultivated. With this fact before me, I should not be at all surprised to hear that considerable portions of the tract under consideration had become impassable morasses in the course of a few years after irrigation commenced.

Mr. Parker formerly relied on the very obstruction of the drainage to which I object so much, as enabling him to dispense in great measure with the necessity of draining at all. But I for one cannot accept the statement that the interception of drainage water does away with the necessity for drainage. True the soil may absorb the water to a large extent, but, to my thinking, it is a more formidable antagonist when thus disposed of than when it is passing off by surface flow.

Mr. Parker has, however, lately admitted in conversation that a system of deep artificial drains will ultimately become necessary, in which case it is surely more in accordance with sound engineering to arrange that all the drainage cuts shall follow the depressions, and the irrigating channels the high lands, than to treat an undulating country as a "*tabula rasa*," the features of which are to be moulded hereafter according to our own will.

If we suppose that there are no undulations, and that the country slopes uniformly down from the main watershed to the rivers shown on the map, the perennial channels will then lie some way down the slope on either side, and will intercept the broad shallow film of drainage flowing over the surface of ground to the river. Any one who has watched the flow of such drainage will, I am sure, admit the truth of my assertion that the obstruction caused by a bank of several miles in length can never be effectually remedied by the construction of a few large culverts at certain points which the amount allotted for drainage shows will not be very near each other.

I have already stated that I object *in limine* to the excessively large monsoon supply which it is proposed to throw into these canals, and which appears to be the sole cause of the complicated system of irrigation proposed for adoption. If it be still considered necessary to adhere to this large khureef volume, it seems to me imperatively necessary to move up both perennial channels to the main watershed now occupied by the khureef canal. They would then lie immediately contiguous to the latter, except where it became necessary to interpose feeding channels for the purposes of supply.

But it seems to me that the great object in the construction of irrigation canals is not so much to obtain a maximum of revenue at a minimum of cost, as to lay them out on sound engineering principles; and, while keeping in view the necessity of obtaining such a return as shall remunerate the State for its outlay, never to lose sight of the physical conditions or necessities of the country which they traverse. Above all things, the health of the irrigating community should be considered of paramount importance, as there is but little use in giving its members luxuriant crops of rice if, in the course of a few years, they have neither health nor strength left to enjoy them.

The reasons given for utilising the large monsoon supply do not appear to me sufficient to warrant its adoption. They are—

1st.—That it is easily available.

2nd.—That if much rice is grown, the duty obtained from the water will be so much less than the standard adopted by the Government of India as to employ the larger volume proposed, even though the proportion of land irrigable every year be estimated at one-fourth only of the cultivable area.

3rd.—That the assignment of one-fourth of cultivated or cultivable area as limit of yearly irrigation is quite below the wants of the people; the canal-irrigated areas in certain pergunnahs of Saharunpore, Mozuffernugur, and Meerut Districts, running as high as from 60 to 70 per cent. of the cultivated area.

4th.—That in certain pergunnahs in which well irrigation is most largely and successfully practised, 80 per cent. of cultivated land is irrigated annually, and that there seems to be no good reason why canal irrigation should not attain the same development when water is abundant.

5th.—That the loss of volume from percolation would probably reduce the available supply to 3,150 cubic feet per second—a volume which agrees practically with the limit proposed by Government of India.

6th.—The necessity for supplying the Lower Ramgunga Canal with water from the Ganges, owing to the late date at which the volume of the Ramgunga River begins to increase.

The first reason is one which can be urged in support of almost all proposals for utilising large khureef volumes, and is I think, only fairly applicable when it can be proved beyond a doubt that the injury to the health of the community and to the low-lying lands (which may be expected to result from flooding the country to so large an extent) will not be out of all reasonable proportion to the advantages gained.

As regards the second and third reasons, I think that most Irrigation Officers in the North-Western Provinces will support me in deprecating strongly either the encouragement of growing large areas of rice, or the acceptance of the wishes of the people as a safe guide for us to adopt in this particular matter. The state of many of the villages in the pergunnahs quoted (in which canal irrigation bears so high a proportion to cultivated area) bears me out in my argument, as some of the very worst cases of suffering from rise in spring level that have come to my knowledge have occurred in these very localities.

As regards the fourth argument, there must surely be some mistake in the returns quoted, which state that 80 per cent. of the cultivated area in certain pergunnahs is annually irrigated from wells. I have asked Settlement Officers of great experience, who assure me that they have never met with any such cases, and suggest that most probably the meaning is that 80 per cent. of the cultivated land is irrigable from wells. Besides, granting that so large a proportion of well irrigation did exist anywhere, there is surely no analogy between such a case, where the water is drawn from the subsoil, sparingly distributed over the surface, and returned to the subsoil in diminished quantity, and the case of 80 per cent. of the cultivated land being flooded with a profuse supply of canal water, which all contributes to raise the spring level instead of lowering it. The irrigation, conducted in the former case with perfect impunity, would in the latter very probably turn the land into a swamp and decimate the inhabitants with fever.

Were the duty obtained from the water in the proposed Eastern Ganges Canal to run as high as the duty obtained from well water, a *maximum* supply of 1,250 cubic feet would amply suffice for the wants of the community.

I shall consider the loss from percolations, stated as the fifth reason, further on (*see page 60*); and think that the sixth reason must stand or fall with the possibility of our being able to devise any means of safely combining large and small discharges in the same channel.

Having regard to the nearness of spring level to the surface of the soil, and to the supply available for use during the rubbee, I am decidedly of opinion that the scheme originally suggested for adoption by the Government of India (*see page 44*), is the best suited to the circumstances of the case. There should be a single line of canal adapted to carry a minimum supply of 1,250 cubic feet a second, and a maximum supply as much in excess of that volume as can be conveniently and economically arranged.

A channel having a bottom width of 135 feet, side slopes of $1\frac{1}{2}$ to 1, and a fall of 1 foot per mile, will discharge a little over 1,250 cubic feet a second, with a velocity of about 2.33 feet per second when flowing 4 feet deep. If the depth in the same channel be increased to $6\frac{1}{2}$ feet, the discharge will rise to about 2,800 cubic feet per second, and the velocity to about 3 feet per second. I see no difficulty whatever in arranging for the maintenance of irrigation from the distributaries within these limits of fluctuation in the main channel, and the experience of the Eastern Jumna Canal will, I know, bear me out in this opinion.

All irrigation channels should follow as closely as possible the watershed lines of the tracts which they are intended to water.

At first it would only be possible to lay down main lines of canal, but no time should be lost in surveying and laying down the minor drainage features of the country, and then each separate "Doab" can ultimately be provided with its independent irrigation channel of a volume proportioned to the area commanded. The water would thus be delivered much more directly on the fields than in the proposed scheme, where the perennial channels leave the main watershed, and have to irrigate much of the land against the transverse slope of the country.

No one can doubt the fact of the area commanded by the Eastern Jumna Canal having been perfectly protected from the effects of drought during the famine years of 1860-61 and 1868-69. The gross area so commanded amounts to 1,550 square miles. The volumes delivered were 1,500 cubic feet per second during khureef, and 665 cubic feet during the rubbee of 1860-61, 1,126 cubic feet during the khureef, and 682 cubic feet during the rubbee of 1868-69. The proportion of barren land to gross area is

almost exactly the same on the Eastern Jumna and Eastern Ganges Canals, being 14·66 per cent. in the former and 14 in the latter case. A comparison may therefore be very fairly instituted between the two, in order to ascertain how far short the reduced volume of the Eastern Ganges Canal will come in protecting the area irrigated by it from famine. The mean volumes of the Eastern Jumna Canal for the two years are 1,313 cubic feet per second for khureef, and 673 cubic feet for the rubbee; and increasing these volumes in proportion to the gross areas commanded, we get 2,900 cubic feet during khureef, and 1,370 cubic feet during rubbee, as the corresponding volumes required for Eastern Ganges Canal. The volumes which I propose for adoption (2,800 cubic feet during khureef, and 1,250 cubic feet during the rubbee), fall short of this standard by about 100 cubic feet per second in each fusi. The short rubbee supply may be lamented, but cannot be helped, as there is no more water to be obtained from the river, while bearing in mind the nearness of spring level to the surface of the soil, I look upon the short khureef supply as a decided advantage. As the loss by percolation is included in the volumes adopted as standards of comparison, no extra provision need be made on that account.

Eighty-six per cent. of the gross area (3,152 square miles) commanded by the Eastern Ganges Canal is cultivated and culturable. The proportion of khureef to rubbee cultivation is as 17 to 10; the khureef duty may fairly be taken as 75 acres per cubic foot per second, and the rubbee duty at 180 acres.

From these data we obtain an irrigated area of 210,000 acres for the khureef or 19 per cent. of the gross cultivated and culturable khureef area; and 225,000 acres irrigated during the rubbee, or 35 per cent. of the gross cultivated and culturable rubbee areas. The returns may be estimated at:—

	Cubic feet.	Acres.	Rs.	Rs.
Khureef,	2,800 ×	75 ×	2·25 =	3,72,500
Rubbee,	1,250 ×	180 ×	1·9 =	4,27,500
Add 8 per cent. Miscellaneous,				72,000
Total (net income),				Rs. 9,72,000

I have adopted the water rates per acre given by the Chief Engineer in his report on the Eastern Ganges Canal, dated 9th December, 1869, and, like him, have reckoned the whole direct income net, allowing that the working expenses will be covered by the landlord rate.

My estimate of the returns looks of course rather dingy when placed

basis the previous estimate of 18½ lakhs obtained from the larger khureef volume, and higher estimate of rubbee duty. But I think that 200 acres is too high for an average estimate of rubbee duty, and I am sure that it will, in the long run, be found much more profitable and advantageous to content ourselves with the lower returns and the reduced volume during the khureef.

It is of course impossible to say at this stage of the proceedings how much per cent. will be obtained as a return on original outlay should the modified scheme be approved. But as its cost cannot be more than that of the present project, which is given by the Chief Engineer as Rs. 81,88,820, we may safely assume that the modified scheme will prove remunerative, as the estimated returns from it (Rs. 9,72,000) will give 11 per cent. on the above-mentioned capital outlay.

Should it be decided to reduce the khureef supply at the head of the canal, it by no means follows that a rateable reduction should be effected in each of the main branches and distributaries. I should recommend cutting down to the lowest possible limit the supply of water allotted to low-lying swampy tracts, and to those where the spring level is within 10 or 12 feet of the surface, giving the surplus to the higher and more arid districts. By this means His Honor the Lieutenant-Governor's wish to provide an ample supply for the portions of the Bijnour District which are so liable to drought can easily be complied with, while we shall at the same time avoid water-logging the district lying between miles 57 and 97 of the canal.

J. L. PARKER, Esq., *Supdg. Engineer, the 20th April, 1872.*

Of the two objections to the project of the Eastern Ganges Canal raised by Colonel Brownlow, the first refers to a point of such importance that it ought to have been definitely settled before the design of a canal, resting as it must do upon that point, was attempted. In other words, the discharges of the canal should have been fixed before their distribution was attempted.

Colonel Brownlow's objections are—1st, that the khureef discharge—viz., 4,500 cubic feet per second—is too great; and, 2nd, that the design for distributing this discharge is faulty, inasmuch as it exhibits interference with the natural drainage of the country. The latter is what I

am concerned with, and ought to reply to, leaving the former to be settled by other authority. But before replying, I would point to the correspondence on the subject as showing that the majority of opinion is certainly against Colonel Brownlow, and that I myself think that if we have water enough to water an entire tract of country, we should water the whole tract, and not a part only. By watering a portion (if irrigation be a benefit) you benefit only a few, whereas by irrigating the whole you treat all alike, and permit the whole community to prosper alike: and this I think but fair.

The second objection—viz., that of interfering with the drainage of the country—is, I think, hardly tenable. I will accept Colonel Brownlow's description of the project of the Eastern Ganges Canal as set forth on page 55; I will also take the sketch of country therein given, and agree that it is not exaggerated; but I cannot see that the irrigating lines need be laid out as shown in the sketch. I would prefer laying them out as in the sketch I append (*Plate VI.*), and would then remark that there is in reality very little interference with drainage, and none that cannot be disposed of. I do not see why a rajbaha embankment should not cross drainage lines quite as effectually as a railway—*i. e.*, by interfering quite as little with drainage. In the sketch I append, the crosses show where either culverts or syphons would be required. The black single lines represent gouls or minor rajbahas. The nuddees (distinguished by water lining) are as far away from the perennial channels as these themselves are from the canals. I mention this to correct the distortion of the sketch, which represents the irrigating lines *a b, c d*, for instance, as very short, whereas they would generally be long and run down watersheds.

As a general rule, the system of rajbahas proposed for the Eastern Ganges Canal does not interfere with the drainage of the country. Two channels—the east and west rubbee—do cross lines of drainage, but can cross these without interfering with the flow of water, and the minor rajbahas springing from the perennial channels can generally be so distributed as to turn heads of drainage, as the line *p q r*, for instance, or cross them at favorable points, as at *s*.

With regard to the rise of spring levels, it cannot be denied that rise does take place on the introduction of a canal into a district. But it does not necessarily follow that morasses should be allowed to form. A proper system of drainage cuts would, I should think, always prevent

DRAINAGE OF THE RAMGUNGA DOAB.

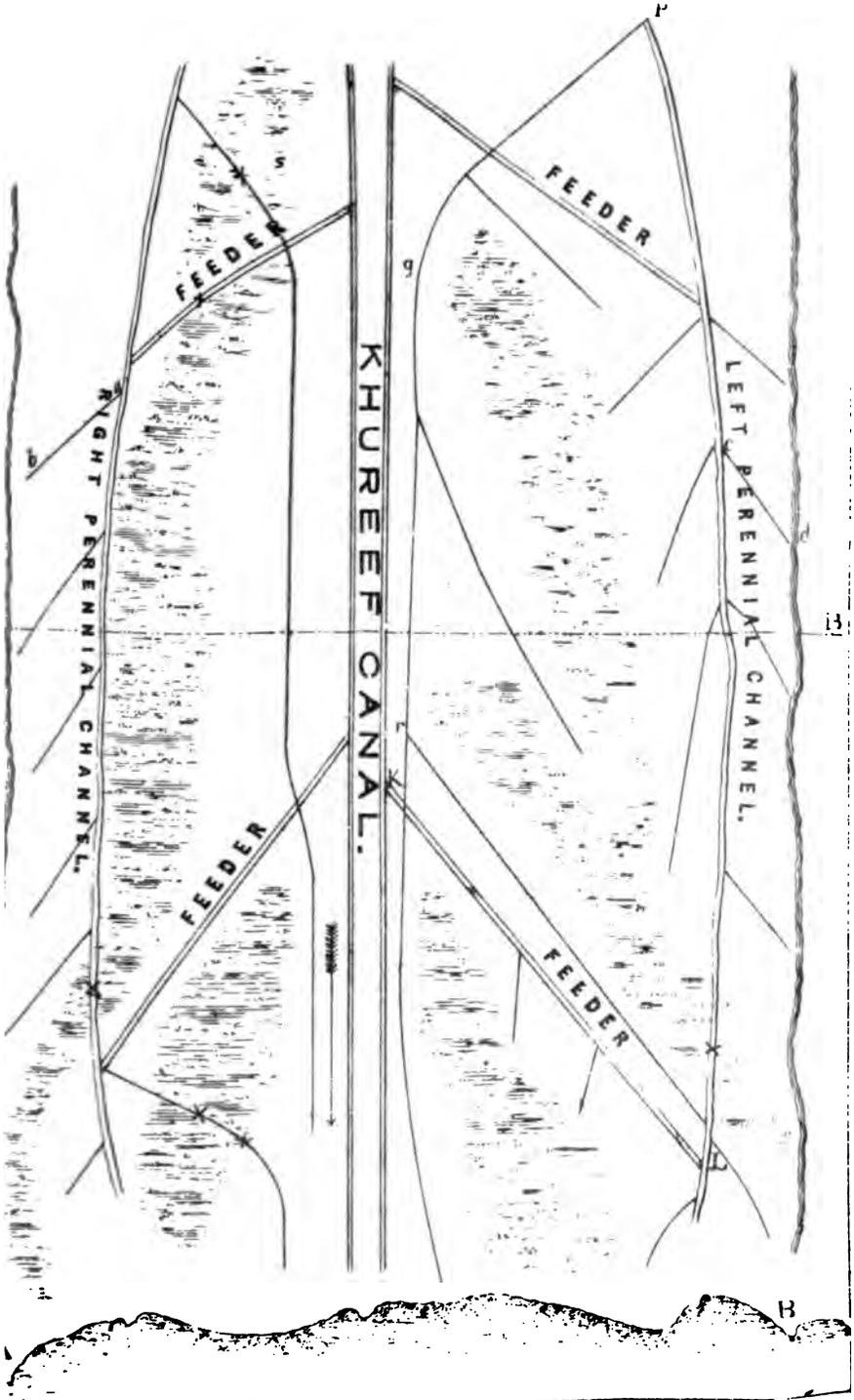



these, as well as the water-logging of the soil; and with regard to the latter only, drainage cuts would certainly restrain it to a depth below soil limited by the depth of the drains. Should this be allowed, I would ask, would such water-logging by the rise of spring level be injurious in any way either to the health of the people or to the fertility of the soil? I myself cannot give any decided opinion on the subject, but am inclined to think that the approach of spring level to surface of soil, as in the Ganges khadir, for instance, does not itself render climate insalubrious; and that as water-logged lands can by drainage be made fruitful, and in England, and I believe in parts of this country, have been so made, so land not water-logged, but with such a stratum 5 feet below it, will not be injured, since it may be viewed in the light of drained lands, which, as above-mentioned, can be made, and are, fruitful.

When writing the paragraph (marginally quoted) of my memorandum

"I believe it will be found that very little drainage works will be required. Besides the favorable features before described of the Ramgunga Doab, where it is itself traversed in all directions by our irrigating lines, feeders, and minor rajbuhas, and by the innumerable watercourses which the agriculturists themselves must make for irrigating their lands, the surface of the country will be so cut up into small areas that each area will retain or consume most, if not all, of the rain-fall upon it, and works will not be required for draining it. Much of the country is sandy, and will absorb water to a large extent."

on the Eastern Ganges Canal, I did not mean that cutting up the country into small areas would do away with the necessity of surface drainage, but that it would diminish it. What I meant may be illustrated thus: Let there be an inclined plane, and let it receive a certain amount of rain-fall; the whole of this will run off rapidly and in large volumes into drainage lines, say on either side of the plane. Let this be now divided into small squares, each capable of retaining a great deal of the rain-fall. This would now not run off so rapidly as before, nor in such large volume, and smaller culverts would be required than before, more water would remain on the whole plane than before, more would be evaporated from it, and more would be absorbed in certain soils tending to render the country water-logged. This would be prevented by drains dug to any required depth,—by subsoil drainage, in fact,—and this I have always thought would be necessary, and must accompany irrigation by canals; and it is my belief that in whatever way you may arrange your distributaries, spring levels will rise, and drainage will always be necessary.

The rajbuhas and feeders as shown in the Canal Survey map will not necessarily run as there shown. Further surveys will be made. Feeders will

be taken down, whenever possible, on a ridge as shown by KL. in *Plata VI.*, and the perennial channels will probably very often run close to the canal, as *p q r*, in sketch, and throw off a branch towards the side of the *nuddees*; and we shall have what Colonel Brownlow requires,—viz., irrigating channels on high lands and drainage cuts in low, with this further advantage, viz., a constant head of supply in our *rajbahas*, without any necessity of damming up the water.

With regard to the spring level being near the surface of country, and irrigation consequently not being necessary or required, experience seems to show that the spring level does not affect the question. In East Rohilkund, water is very near the surface of the soil in the Districts of Bareilly and the Terai, and yet the people have irrigated from time immemorial: more than that, although in numerous places the water is within 10 feet of surface of country, Government has sanctioned canals to be made in these places, and they are in fact being made. It naturally occurs to one of course to ask, if you sanction canals to be made under a certain condition of circumstances in one part of a province, why prohibit their construction in another, where circumstances are exactly the same?—and also to conclude that if the habits of the people be supposed to indicate the usefulness or necessity of certain practices, the nearness of water to surface of soil does not do away with the necessity or usefulness of irrigation.

With reference to Colonel Brownlow's proposed section, I would not advise changing the side slopes of the canal from $1\frac{1}{2}$ to 1, or slope of bed to 1 foot. There seems to be no reason why 1 to 1 for side slope should not be maintained; and, indeed, a very good one for its maintenance. It is sufficient as a side slope to answer its purpose, and in depths of digging such as we have in the upper 20 miles of the canal, (viz., 50 to 55 feet,) vastly cheaper than $1\frac{1}{2}$ to 1; and with regard to slope of bed, of course the more this is, the greater will be the excavation and the consequent expense.

I think I have nothing more to note down, except just to express my belief that the conditions of the problem being granted, the Eastern Ganges Canal project meets them quite successfully; that wherever canal irrigation is introduced, rise of spring levels must take place, whatever the system of distributaries may be; that drainage must accompany irrigation, and can always be made to cross irrigating lines effectually without injury to country by proper arrangements; that with regard to the discharges of

the Eastern Ganges Canal, they should be maintained at 4,500 and 1,200 cubic feet; and that, if so maintained, it will be difficult to find a more satisfactory or less complicated solution of the difficulty of maintaining a constant head of supply than that proposed.

And in conclusion, I would beg to express my obligations to Colonel Brownlow for his courtesy in allowing me to see his notes, and thus giving me an opportunity to reply to them.

Col. H. A. Brownlow, R.E., 6th May, 1872.

As regards the question of khureef volume to be given to the canal, Mr. Parker considers that the late Colonel J. C. Anderson tacitly accepted the proposed discharge, because he made no objection to it in a note on the project dated 25th August, 1870. But a reference to a note (below quoted) by Colonel Anderson, dated 7th September, 1869, will show that he did not then at any rate consider it at all advisable to provide canal irrigation for a very high proportion of the *cultivated* area, or to provide more than 3,000 cubic feet per second for the whole canal.

Extract from Note by Offg. Inspector-General of Irrigation, dated 7th September, 1869.

Para. 3.—Considering the generally moist character of the country to be dealt with, and the proximity of the springs to the surface, which would continue to offer the means of irrigation after the opening of the canal, I am not inclined to recommend provision of canal irrigation to a very high proportion of the cultivated area.

Para. 4.—If these figures are any criterion of the results which may be anticipated from the Eastern Ganges Canal, I should think that provision of the means of irrigation to the extent of one-fourth the khureef area would be sufficient. In this case the supply, as above mentioned, would be 3,000 cubic feet for the whole canal, and 1,100 for the Sambhal Branch; but Colonel Strachey will be able to give a more reliable opinion on this point.

Mr. Parker, while accepting my sketch of the probable drainage features of Western Rohilcund, takes exception to the manner in which I laid down the distributaries in that sketch, and further on he says that the rajbuhas and feeders will not necessarily run as shown in the map submitted with the project. I was very naturally guided by the statements of their own views put forth by the designers of the canal, and a reference to their correspondence will show that I represented as fairly as I could the system of distribution which it was proposed to adopt. If my remarks have led to a more careful consideration and a modification of this system, they will at any rate have done some good.

Looking upon it as an axiom in hydraulic engineering that irrigation channels shall, where it is possible, occupy the watershed lines of the country, I cannot accept Mr. Parker's statement that his rajbuhas do not,

as a rule, interfere with the drainage, as a sufficient argument in support of the system proposed by him. The variations in the features of the ground are very great, and until we are furnished with a fairly accurate topographical map of the country we cannot be sure that the admission of the principle that the watershed may be safely abandoned will not lead to very serious interference with surface drainage.

Mr. Parker, while admitting that a considerable rise in spring level will follow the introduction of canal irrigation, proposes to restrain it to a certain depth below the surface by a system of drainage cuts, and he inclines to the belief that such an amount of water-logging would not affect injuriously either the productive powers of the soil or the health of the people. There are, I fear, a good many practical contradictions of his opinion on the latter points, and in order to keep the surface of spring water down to a safe level under the proposed conditions of irrigation, we should require a widely extended system of deep drainage cuts. It does not seem to me in accordance either with sound engineering or principles of economy deliberately to make a swamp with the avowed intention of draining it sooner or later.

In regard to Mr. Parker's allusion to the Rohilcund Canals, it is precisely because I object most strongly to the sanitary condition of parts of Bareilly and the whole of the Terai that I am protesting so strongly against the lavish supply of water to parts of Western Rohilcund. Mr. Parker's argument refers to construction of canals, and I think he would on consideration allow that I did not in any way object to the construction of the Eastern Ganges Canal, but to the grant of an excessive supply of water for khureef irrigation.

The case put on page 59, and objected to by Mr. Parker, is purely hypothetical, and merely intended to show what would be the probable increase of volume conveniently attainable in a channel discharging 1,250 cubic feet per second as a minimum supply.

Col. H. A. Brownlow, R.E., Extracts from Instructions for revising Eastern Ganges Canal Project, 4th April, 1872.

The maximum rubbee supply should be taken at 1,250, and maximum khureef supply at 2,500, or, if it can be managed, even 2,800 cubic feet per second.

The lining out and preparation of land plans should be proceeded with,

and in lining out the greatest care must be taken to follow as closely as possible the watershed lines of the country.

It is believed that the main watersheds have already been determined with sufficient accuracy, and no time should be lost in pushing on the surveys and in taking the levels that are required to enable the Engineers to lay down correctly on the map the minor drainage features of the country.

The complete delineation of these will of course be a work of time, but by commencing with the most marked, and gradually working in the smaller ones, there is no reason to doubt that it will be possible to complete the distributaries quite as soon as the main channel. It is not intended that there shall be a complete and minute contour survey of the whole country, but we must have a clear conception of the position and direction of the minor watershed and water-course lines. A flying survey taken after very heavy rain, would, if correctly done, convey much more really useful information for our purpose, than the most accurate series of levels if taken only at 5-mile intervals, and merely given as *levels*, without any attempt to show whether a sudden drop is caused by an isolated depression or by a comparatively important drainage course.

Under the above system, each distributary will occupy the water-shed line of its own particular "doab," leaving the drainage courses perfectly open and free.

The volume to be allotted to each distributary will, as a general rule, depend primarily on the nearness of the spring level to surface, and secondarily on area commanded. This rule is, of course, not to be considered inflexible when the local knowledge of the Superintending and Executive Engineers engaged in designing the works can show good grounds for departing from it; but, speaking generally, the volume allotted per square mile of any given area should be in the direct ratio not only of area, but of depths of water below surface of soil.

As some general rule must be adopted at the outset in order to admit of the Engineers ascertaining with fair accuracy what will be the volumes to be provided for in the several main channels, I would suggest that the several areas commanded should be divided into three classes:—

Class A.—Spring level 12 feet or less below surface of soil.

Class B.—Spring level 12 feet to 20 feet below surface.

Class C.—Spring level more than 20 feet below surface.

Then areas of A, B, and C, should be ascertained, and supposing 652 (A) + 1,500 (B) + 1,000 (C) = 3,152 square miles total area commanded; if x = unit of volume per square mile for Class A ($652 \times x$) ($+ 1,500 \times 2x$) + ($1,000 \times 8x$) = 2,800 cubic feet, and $x = 0.42$ cubic feet per second: the allotment of maximum khureef supply would then be say—

0.40 cubic feet per second per square mile to Class A.

0.85 " " " " " B.

1.25 " " " " " C.

The foregoing calculation is only an illustration, and it is apparent that the volume per square mile allotted to Class A, will vary according to the varying proportions of the areas in the three classes. It might therefore be necessary to fix a limit below which the khureef volume allotted per square mile should not fall. I do not think that 0.33 cubic feet per square mile would be at all too low a limit for tracts where the spring level is within 10 feet of surface, and it will of course be understood that it is by no means necessary to dole out a modicum of water proportioned to its area to each village of such tracts. The lowest-lying lands, which will be furthest from the rajbuha, will be most beneficially excluded from canal irrigation in the great majority of cases, and the waste consequent on attempting to lead small streams of water long distances will thus be avoided.

No. LXVIII.

MASONRY *VERSUS* EARTHEN DAMS.[*Vide* Plates VII, VIII. and IX.]

BY MAJOR HECTOR TULLOCH, R.E., *Executive Engineer, Bombay Municipality. Extracted from the "Report on the Water Supply of Bombay."*

In every project hitherto submitted for storing water for Bombay, it has been proposed to make the dams of earth.* I will now discuss the question whether we should do well to adopt this material.

Most of our experience of earthen embankments is obtained in England, where it is almost the universal custom to use clay in preference to masonry. But hardly any one conversant with this branch of Engineering would say that the works of this kind at home, taken as a class, are satisfactory. In consequence of the failure of some of them, the most frightful catastrophes have occurred. Those who have given much attention to this subject, will probably be disposed to agree with me, that the whole science of dam construction, must before long, undergo a great change. It is not generally known that many of the deep reservoirs in England are never filled to the height to which it was originally intended by the projectors, that they should be filled. To prevent any risk being incurred, the greatest caution is exercised at this present moment in the management of these reservoirs. The penalty of failure is so awful, that the surface of the water is kept twenty and thirty feet below the original proposed level. When we remember that high earthen

* I do not include Mr. Walton's projects. I believe he came to the same conclusion as myself regarding the superiority of stone for dams in the Concan, from the consideration of the facts brought forward in this Article which were known to him.

dams are quite a recent innovation, it is only natural that this branch of Engineering should not be in a very advanced state.

The ordinary mode of construction adopted for works of this class, may be explained in very few words. With a breadth of from twenty to thirty feet at the top, the dam slopes towards the water with an inclination of three feet in length, to one of height, and in the opposite direction, with an inclination of two and a half feet to one. Along the middle of the dam and carried down (as it should be, though as it often is not) to a firm impermeable bed, is a wall of clay, technically called *puddle*. This wall is usually about ten or twelve feet wide at the top, and thickens as it descends at the rate of about two or three inches for every foot of vertical distance. On either side of the puddle is placed what is termed 'selected material,' that is generally, the best that can be got at the spot. The rest of the dam is formed of almost any kind of suitable earth. In order to break the force of the waves, and to prevent them from washing away the earth underneath, the slope towards the water is usually covered with a layer of stones, or *pitched*, as it is termed. The outer slope is turfed or pitched, according to the judgment of the Engineer.

It is the puddle wall which should form the barrier to the escape of the water, and it is this part of the embankment to which the Engineer trusts more than to any other for the safety of his works. The greatest care should be taken both in the selection of the clay, and in the manner of putting it in the embankment. It should be thrown down in thin *concave* layers, as should also the rest of the dam, and should be with the rest well watered, and rammed, and beaten, and trodden down, so that the whole mass may be rendered as homogeneous as possible.

Until lately it was a common practice to lay the outlet or supply pipe through or under the embankment, and, in some cases, even without preparing a special foundation for it.* The great loss of life and destruction of property caused by the bursting of the Bradfield reservoir has, however, effectually put a stop to this system, and arrangements are now generally made by which the outlet works are altogether disconnected from the dams. We have in fact learnt by disaster, what common sense should have taught us from the first. The dam, being naturally

* The outlet pipe from the Vehar Lake, unfortunately for the town of Bombay, has also been placed under one of the dams.

the weakest part of the reservoir, should be that which we could least afford to endanger by works liable in the course of nature to get out of order. The practice now obtains of carrying the outlet pipe through some one of the hills standing on the margin of the lake.

This being the English mode of dam construction, let me now revert to the Continental one.

In France and Spain, the two countries in which we find so many large reservoirs, the people put no faith in puddle and earth, except for dams of moderate height. They trust to masonry, and certainly they have no reason to complain of misplaced confidence. It is quite true that some of their dams have failed, but the causes of failure are so well known and so easily avoided, that far from the material being distrusted by them in consequence, their faith in masonry has, on the contrary, largely increased, and is characteristically exemplified by their later works.

I doubt whether at this present moment there are three dams in England which could hold water to the depth of a hundred or even ninety feet without danger: there are dams, to my knowledge, constructed above this height, but they are not filled, as I have already pointed out.

This state of things contrasts most unfavorably with that in France and Spain. Some of the dams in the latter country have stood for hundreds of years, are in use to-day, and, although constructed at a period when science was but emerging into light, and when, therefore, no great knowledge of the theory of the subject could be expected, yet, from their having been built of masonry, still answer all the purposes of the original designers.

The Spanish dams are of huge proportions, and, having been built according to no generally accepted rules, there is very little similarity between even any two of them. It would, therefore, be impossible for me to give any description of them which should apply to all. A better idea will be formed of them from the accompanying drawing, than by anything I could say, *vide Plate VII*. Some of them have the most grotesque forms. One Gros Bois, *vide Fig. 13*, has a greater slope on the water side than on the other. Another that of the Val de Inferno, *vide Fig. 8*, has such a hideous form, that it naturally suggests the idea of its having been designed in that region. Rude though as these works seem to us by the light of modern science, it is a greater point that they still exist and still fulfil their object. In other words, they have been successful in

spite of the errors made in constructing them. It is not likely that these errors will be repeated.

The construction of masonry dams has passed through a new stage within the last few years, and this in consequence of the success of a French work, which is unique in its character, as showing what science and art can really effect when brought to bear on a subject.* We talk in England of dams a hundred feet in terms of admiration, and we look at such works almost with feelings of awe, but the French have constructed a dam one hundred and sixty four feet high, impounding water up to the top, and successfully resisting the enormous pressure, *vide Fig. 5, Plate VII.* The boldness of the design, and the constructive skill with which it has been carried out, are only to be matched by the consummate mathematical knowledge with which the whole principle of dam construction was previously investigated. The French Engineers have reason to be proud of their success. They have demolished empiricism, and established something like law at last. The old rule of thumb principle of making every dam at the base about three-quarters, in the middle about one-half, and at the top about a quarter of the height, has little foundation in mathematical science. Such a dam is far too thick at the top, and far too thin at the bottom, *vide Plate VIII.*, and there is an excess of material in the entire work which, in a high dam, so far from adding to its strength, positively detracts from its equilibrium. But, before I attempt to explain the views of the Frenchmen, I must give their opinion of earthen dams. It is not flattering to us, and it will no doubt provoke surprise among those whose acquaintance with dams does not extend beyond the examples existing in England. If we did not find the impression contradicted by the modest tone of Messieurs Graeff and Delocre throughout their papers, we might almost fancy the Frenchmen, from the matter-of-fact way in which they put it, were quietly laughing at us in their sleeves. With a simplicity that has almost a touch of humour about it, they say:—

“It is not necessary to consider the plan of constructing dams of earth, which are things of chance, when they attain a height of 20 mètres (65·6 feet), and it is out of the question to use this construction for a

* Colonel Fife, R.E., has rendered a great service to the profession by the publication of his translation from the “*Annales des Ponts et Chaussées*,” of Messieurs Graeff and Delocre’s papers on the subject of masonry dams. It is not too much to say that those who are unacquainted with these papers, have much to learn, both of the theory and practice of dam construction. All the information in *Plate VII.* is taken from Colonel Fife’s valuable pamphlet.

Theoretical Type]

Theoretical Type (without Steps)
130 lbs on the Square Foot.

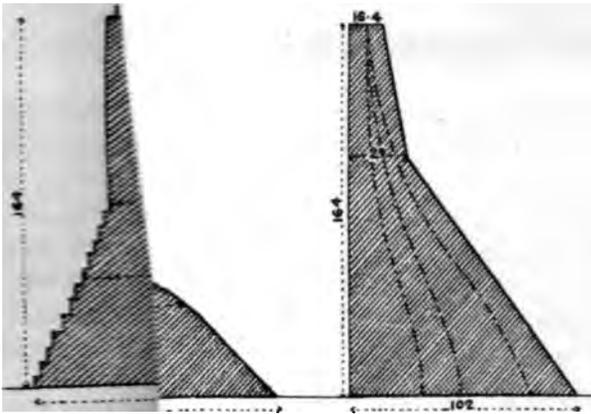

5

Dam of Gen
Reservoir

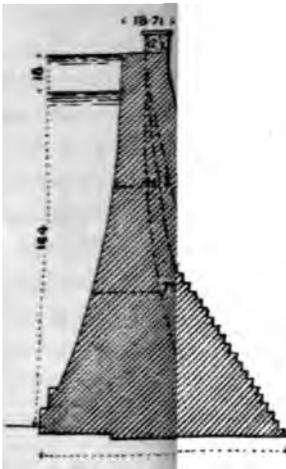

8

Dam of Val de Inferno.

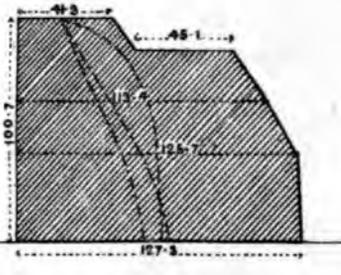

14

Dam of Alicante.

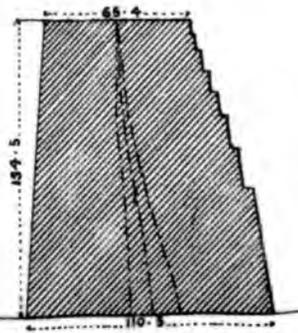

Dam of Nijar.



13

Dam of Gros Bois





height of 50 mètres (164 feet), which we have now under consideration. After passing the lesser height, we have only to deal with dams of masonry.*

And accordingly the Frenchmen utterly ignore the whole class of earthen dams above 65 feet high which are found in England. The case of high earthen dams they dispose of in the summary judgment given above, and it does not even occur to them that any one could have the temerity to dispute the point. They at once pass on to the subject of masonry, and I will now try and give a condensed view of their opinions and conclusions.†

A masonry dam is liable to be destroyed in three ways. It may be overturned by the thrust of the water. It may slide on its base, or its joints. Or it may crush vertically from its own enormous weight.

1st. There is no case on record of any dam having been overturned. In fact, to calculate the thickness of a dam which shall resist the pressure of the water to throw it over, is a very simple problem. Practically a dam which satisfies the other conditions of construction will be found to satisfy this one also. When those conditions are satisfied, a simple calculation will settle this point. We may, therefore, for the present, discard the consideration of the liability of the dam to be overturned.‡

2nd. There is no instance of any dam having been destroyed from its having slidden horizontally. This, therefore, is not an important point. After the third condition has been satisfied, the solution of a very simple equation § will settle this question.

* I believe myself, that if all English Engineers could be asked, the majority would say that this is just about the height at which dams begin to be dangerous.

† It is necessary I should say that the following exposition of the subject is, and intentionally so not a scientific, but a popular one. My object being to convey to the public such a view of the question as shall be understood by them, I have purposely, discarded, as far as possible, the use of technical language, and have altogether avoided the mathematics of the problem. Those who care for the latter, I must refer to Colonel Fife's pamphlet, in which, I venture to say, they will not complain of the absence of formulæ, nor of these being of too simple and elementary a nature.

‡ The Frenchmen hardly consider this subject directly, but I gather it from some of their incidental remarks, and from their method of mathematical analysis.

§ "Calling H the height of any course below the summit, the force which tends to produce sliding on this course is equal to the horizontal component of the thrust of the water against the part of the interior face situated above that course, and it is given by the equation

$$F = \frac{\delta H^2}{2}$$

The resistances which are opposed to the action of this force are the friction of the two courses which tend to slide upon each other, and the force of cohesion of the masonry.

The friction is proportional to the weight of the upper part of the structure, and the force of cohesion to the thickness of the wall.

Calling f the co-efficient of friction of the masonry, γ the force of cohesion per superficial unit, s

3rd. Every dam that has been destroyed hitherto has crushed in from its own weight. Nobody can fail to see at a glance, the importance of this fact. To add more material than is necessary is not to strengthen, but to weaken your work. The old Spanish idea of making dams of huge proportions on no mathematical principles at all, has resulted, as already mentioned, in some lamentable failures. To look at the dam of Puentes, *vide Plate VII., Fig. 7*, one would at first be inclined to think that such a cyclopean structure would almost have answered to stem the tide between the Pillars of Hercules. But what is the fact? The giant succumbed not from the thrust of his adversary, but from his own weight. In fact he was too heavy for his work. The ground literally could not sustain him, and in 1802 he was *hors de combat*. Some of the Spanish works have cost fifty and even a hundred per cent. more than they need have, and are now subjected to causes of destruction, which would not have existed, if they had been constructed with half the quantity of material better disposed, and which far exceed in intensity all the forces of the water against which only the Spaniards strove to contend. In fact, in trying to avoid the dangers of Charybdis, the Spaniards have fallen on Scylla.

This then being the case, viz., that the most important point in the construction of high masonry dams is the consideration of the causes which tend to make them crush in—the French Engineers have devoted great pains to the thorough investigation of the subject. The principle with which they start is this:—

Suppose a dam is to be built of stone and mortar. Manifestly no stone

the surface of the part of the profile situated above the course under consideration, and b the thickness of the wall at that point, the resistance to sliding will be

$$R = \delta' f + \gamma b$$

and it is necessary that we have

$$s \delta' f + \gamma b > \frac{\delta H^2}{2}$$

or,

$$2 \frac{(s \delta' f + \gamma b)}{\delta H^2} > 1.$$

This inequality should be verified for all the horizontal sections of the profile, by giving to f and γ the values proper to the materials that may be employed.

It is equally necessary to verify it for the base of the foundations; f and γ would represent then the co-efficient which are applicable to the ground upon which the structure rests.

It will be convenient in practice, for more security, that not only should the ratio $2 \left(\frac{s \delta' f + \gamma b}{\delta H^2} \right)$ be greater than unity, but that it should not descend below the value found for that ratio in the walls of existing reservoirs which have not suffered injury on trial." *Vide page 56 of Colonel Fife's Pamphlet on "Dams of Masonry."*

could be used unless it were of the best, or at all events of a kind fit for building purposes. Such a stone must necessarily be stronger than mortar. Mortar, therefore, being the weaker material of the two, it is essential at the outset to ascertain the resistance to compression of the particular mortar proposed to be used. Thus, on the strength or the weakness of the mortar, which is the strength and the weakness of the dam, must the calculations for the form of the latter be based. Of course a large margin must be allowed as a factor for safety. In the case of the Furens Dam, the Frenchmen assumed that the safe amount of compression to which their mortar might be subjected was 80 lbs. on the square inch. It was necessary, therefore, that the pressure on no horizontal layer of the dam should exceed this. It might be less, as of course it must be in every dam for some distance from the top, but it was not to be more. Assuming then a practical width for the top of the dam, and proceeding downwards, immediately we come to that layer where the pressure approaches 80 lbs. on the square inch, we must commence increasing the width of the layer, so that, as we go lower, still no portion of the masonry shall be called upon to resist more than the allotted amount of compression.

But another point must be borne in mind. It is manifest that every dam must be exposed to two different sets of conditions. One set when the reservoir is empty, and when, in consequence of there being nothing to relieve the weight of the masonry, the pressures on the inner face become most intense, and the other set when the reservoir is full, and when, therefore, in consequence of the thrust of the water, the pressures on the outer face become most intense. The outer and inner faces, therefore, being those parts of the dam which under different conditions, are subjected to the greatest pressures, care must be taken that the pressure of 80 lbs. on the square inch is not exceeded on the inner face when the reservoir is empty, nor on the outer face when it is full.

There is yet another point to be considered. In very narrow valleys where, by giving a curved form to the dam, part of the pressure of the water may be conveyed to the hills on the sides, the dam need not be of so strong a section as in a wide valley, where it cannot act as an arch, and where, therefore, the whole thrust of the water must be borne by the masonry itself. The French Engineer, Monsieur Delocre, has calculated

the theoretical forms of two dams to suit these different positions. These are given in *Figs. 1, 2, 3 and 4, Plate VII.*

The Furens dam is of the former type, but, in order to make the work a pleasing object to the eye,* the faces of the dam have been gracefully curved as shown in *Fig. 5.*†

Having now obtained the form of the dam according to the third of the conditions we started with—viz., that the material shall not crush in by its own weight—a simple calculation will at once prove that the first and second conditions are also satisfied—viz., that the dam will neither be overturned, nor slide on its joints. Moreover, certain practical points almost naturally suggest themselves, but even these were, I believe, never adopted till the Furens Dam was built.‡

In order that the pressure may be equally distributed throughout the

* The French lay great stress on the aesthetic aspect of the dam, and some of the objections brought against their work under this head, though they would be ridiculed by the so-called "practical" Englishmen, were most gravely considered by them.

† *Fig. 6* is a section of the dam which, in consequence of the success of the Furens work, was proposed to be constructed across the Ban, in a locality where the lime was exceptionally good. The boldness of the design does great credit to the French.

‡ I have paid a visit to the Furens Lake, and have examined it closely. Standing on the top, the dam does not look nearly so grand a work as it really is, but when seen from below, the proportions of the work at once impress the beholder with their magnitude. Although the inner face slopes a little towards the water, it is difficult to believe that it is not perpendicular, in so perfectly a straight line does the wall seem to descend. The gorge across which the dam has been built is a narrow one, not more than about 350 feet wide, and the stone used in construction was quarried from the hills on the side. If samples of this stone, which will be recognised as gneiss, as also of the mortar found lying about the dam, are compared with Bombay building materials, it will be seen that the building stones of Bombay, which abound in every hill and valley, do not suffer by comparison, nor is there any reason to suppose that the mortar is superior to that made from the lime procurable in Salsette. For building purposes, I should prefer the hard traps of Bombay to the Furens stone, and although my experience of the Salsette lime is small, yet, from what I have heard of its strength, if allowed to harden away from the influence of water, I have no doubt that the Bombay mortar used in a dam would be as successful as we could wish.

The rock about the Furens dam is fissured wherever the quarried face of it can be seen, but like the hard strata about Bombay, I doubt whether the fissures extend deep into the rock. The faces exposed to the air have an appearance very similar to the exposed surfaces of the Bombay stone.

At the time of my visit the water was rather low in the lake, there being only about 90 feet depth in it; I had thus a good opportunity of examining the inner face of the dam. The masonry looked as sound as it well could, but as a work of art its appearance was not enhanced by the numerous iron rings which have, for the purposes of facilitating future repairs, being fixed in it.

The surface extent of the impounded water is ridiculously small, when compared with the great height of the dam. In fact, the water looks more like a long winding canal than a lake. Of course this is caused by the fall of the stream being so great, that even the dam of 164 feet high does not send the water back very far. The Veihar lake, as a waterspread, has a far more imposing effect. The tortuous course of the stream, which runs in and out constantly among the hills, quite destroys the grandeur of the Furens lake, however it may add to the beauty of the scenery. At the time of my visit there was not much water flowing into the lake, the stream being about four or five feet wide, and only an inch or two deep.

Almost the entire outer surface of the dam below the then water-line was sweating—i. e., covered

work, the dam should be one homogeneous mass built in every part of the same kind of material. No interior or exterior facing of ashlar which may have a tendency to separate from the rest of the work, and no partial use of cement or concrete, must be permitted. In order, moreover, to increase the resistance to sliding, horizontal courses must be rigorously avoided. The dam must simply be a mass of uncoursed rubble, without any hollows, every portion resembling the rest of the work as closely as possible.

Previous to my acquaintance with the mode of dam construction adopted by the French Engineers, I had for many years been of opinion that the ordinary form given to masonry dams was wrong in principle, and occasioned great waste of material. I considered that, with the view to save material, and in order to make the least quantity of it effectually resist the pressure of the water, the centre of gravity of the dam should be thrown inwards as much as possible, and that this could only be done by making the dam lean as it were against the water. Of course I was aware that this principle, even if correct, could only be adopted for dams of moderate height,* because when the height became considerable, the vertical pressure of the masonry itself along the inner face would become so great, that the material must yield and crush in. The perusal of the French papers did not satisfy me that my position was

with a thin film of water exuding through the pores of the stone. I did not observe anything worse than this, nothing that could be termed a leak.

The water is taken to the town of St. Etienne by a channel several miles long. I walked along the entire course of this channel, which has throughout been built in open cuttings made on the slopes of the hills. Even where the slopes are very precipitous, as they are in some parts, the channel has been built in this way. The stone excavated in making the cuttings, which are from 10 to 30 feet deep, furnished the material for construction. After the conduit was completed, the cuttings were closed again with the débris. As a matter of course, the channel follows the configurations of the hills, but the hills below the dam do not wind much, so that open cutting in the case of the St. Etienne works was probably found preferable to tunnelling as in the case of Glasgow. The conduit runs at a considerable height, from 150 to 300 feet or more, above the bottom of the valley, and, where streams occur, the water is made to pass over the conduit. There is not a single siphon along the line. The slope of the channel is tolerably uniform throughout, except at a few points, where, in order to bring the water to a lower level, it has been dropped as much as 20 feet in 150. I could find no ventilating shafts. At very irregular intervals, of from 50 to 250 yards apart, there are manholes leading into the conduit, but these are all stopped up with simple slabs of stone, shutting close down on the openings. This is an interesting point for those who may think it necessary to ventilate channels intended for the supply of pure water. If the water to St. Etienne had been rendered impure from the want of ventilation, we may, I think assume, that the French would have constructed them before this.

There is much more that I could add about the Furens works, but I have given merely those facts which have a special bearing on the Bombay Water Supply.

* For am I yet convinced that the system would not be the best for low dams.

untenable. Considering that the question involved to the Bombay public the saving of lakhs of rupees, I applied for, and obtained the sanction of Mr. Crawford, the Municipal Commissioner at the time, to refer it to Mr. Rankine. I thought that both the public and my brother Engineers, would receive with as implicit confidence as myself, any views on the subject which Mr. Rankine, who stands at the head of the profession in its theoretical branch, chose to communicate. In Appendices A, B, and C, will be found the correspondence between myself and Mr. Rankine, and *Plates VIII., and IX.,* are illustrative of the subject.*

Mr. Rankine doubts whether any earthen dam is to be relied upon when the depth of water exceeds 100 or 120 feet. He insists upon rubble masonry without continuous courses as the best material, and upon there being no hollows left in the wall. He likewise agrees with the Frenchmen that the intensities of the pressures shall not exceed certain limits on the outer and inner faces of the wall. He, moreover, urges that, wherever it can be done, the dam should be constructed in a curved form, so as to relieve the masonry of as much thrust as possible by carrying it to the hills on the sides. At the same time he considers, in the present state of science, that the calculations of stability, treating the dam as a horizontal arch, are so uncertain as to be of doubtful utility, and, although he would give the dam a curved form, yet he would not rely on it as an arch.

The main points on which Mr. Rankine differs from the Frenchmen are these: that the limit of pressure on the outer, need not be so great as that on the inner, face, and that my proposal to throw the weight of the wall more inwards tends to realize this principle, but he objects to its being carried so far as to make the wall overhang—that the intensity of pressure on the outer face should not be the same throughout, but gradually diminish at the lower part where the slope increases; and, in order that there should be no appreciable tension at any point of the masonry, whether at the outer face when the reservoir is empty, or at the inner face

* I wished to dispense with my own letter altogether, but only in fairness to Mr. Rankine, in order to show what the question put to him was, and how it was stated, have I felt bound to give my letter. The reader must therefore excuse its appearance in the report.

I beg to draw the attention of the profession to the value of Mr. Rankine's papers. They throw a flood of light on the subject, and, confirming as they do in a remarkable manner most of the deductions of the French Engineer, Monsieur Delocre, to whom the credit of the Furens Dam belongs, they ought to satisfy the Bombay public that we shall not go very far wrong by building our dams on the principles theoretically established by the highest authorities in France and England, and actually carried out in practice with the greatest success in the former country.

the level below which I assume
 a dam that the water is not
 off, in fact the permanent
 of the lake

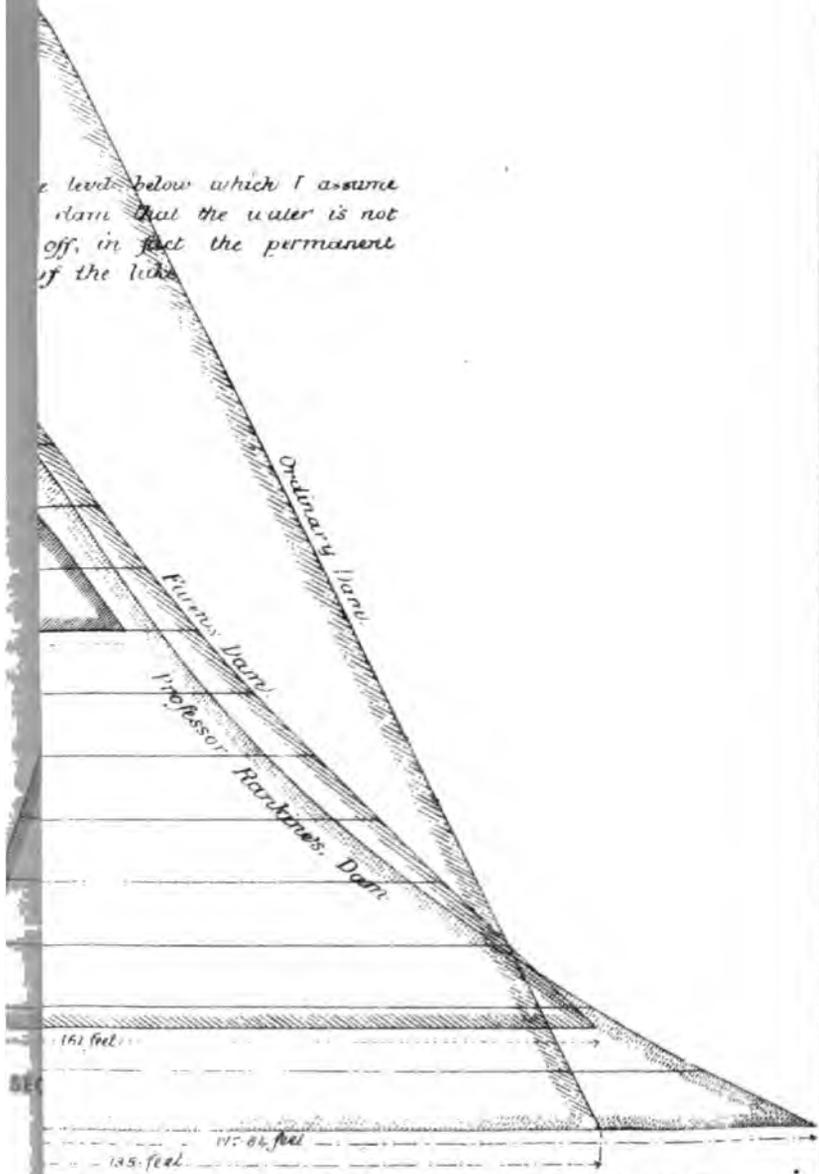

DIFFERENT FORMS OF DAMS ALL PROJECTED FROM ONE POINT,
 POINT BEING THE TOP OF THE INNER FACE.

when the reservoir is full, "the line of resistance should not deviate from the middle of the thickness of the wall to an extent materially exceeding one-sixth of the thickness—*i. e.*, that the lines of resistance, when the reservoir is empty and full, respectively, should both lie within, or but a small distance beyond, the middle third of the thickness of the wall."

Seeing then that Mr. Rankine confirms the correctness of the new principles on which the Furens Dam has been built, and bearing in mind the great success of this work, let me point out what the practical result of these new theories is.

According to the old rule, the average thickness of the wall is about half the weight. Now it is a little more than one-third the height. The saving in material amounts to more than twenty-five per cent.! This saving on any project which may now be carried out for Bombay, will represent a large sum of money.

Although I have purposely not referred to the point, still the reader will understand at once that dams of solid masonry, with their enormous weight, are only suited to sites where foundations of solid unyielding rock are found. The French Engineers insist on this as a *sine quâ non*, pointing out that merely an ordinarily good foundation, or one on which we might safely trust many other structures, will not suffice for masonry dams. If solid rock is not found, the idea of a heavy masonry dam must be abandoned *at once*. Mr. Rankine expresses the same views in other words.

This brings me to the point where the subject interests the Bombay public so closely.

In the elucidation and investigation of projects we Engineers must necessarily be to a great extent theorists, but in the application of our science, we must be practical men. Masonry dams may be very good things in their way, but are they better suited than earthen dams to the country, where our reservoirs would be situated, because this is the whole gist of the matter?

It is the consideration of this very point which induces me to adopt the former. The Concan is a country far better suited to masonry than to earthen embankments. Good clay for puddle, the essential part of every earthen dam, is not to be found. The only clay available is that obtained in paddy fields, which after all is impregnated with a great deal of vegetable matter liable to decay. Those remarkable beds of stiff clay found in so many parts of England do not exist here. The fact of the

difficulty of procuring clay sufficiently good for bricks, even is itself a significant fact, indicating the general absence of this material.

On the other hand, stone, the very best stone which the most exacting Engineer could wish for, lies in untold abundance almost everywhere under his very feet, and in nearly every hill. Still further, there are but few sites for dams in the country about Bombay where a foundation of solid rock does not exist, either at the very surface, or at a moderate depth below it, and where stone may not be procured on the site itself. In fact, the question as to whether there is a stone foundation and abundance of rock has generally been dismissed by me in a few moments by the plainest evidence which any Engineer could require, but the question as to whether there would be sufficient puddle or even earth has demanded grave consideration. Let me explain, by way of illustration, the sites for the dams in those valleys which demands investigation.

The Kennery Dam would stand over a river, the bottom of which is solid trap rock, and would rest against two hills, which also are rock, and there is enough stone at the site to build a hundred Great Pyramids. Good earth could not be procured except at the distance of a mile, and, as for clay, we should have to search the country all around, or else denude the paddy fields, within a radius of two miles from the work, of the material which renders land of this class so valuable, and would to us be so expensive.

The Toolsee Dam higher up in this valley is equally well situated for a work of stone, and very badly situated for one of clay and earth.

The Ewoor Dam would stand on a site still more favorable for rock than even the Kennery Dam, and I need not, therefore, dwell at all on it.

The Kamun Dam is the only one of those proposed by me which *might be* built of earth; but even here I should prefer stone as the best material. The dam would be considerably higher than the limit of safety for earthen embankments, according to the French Engineers, and would reach the limit fixed by Mr. Rankine, and rock is not found except at about twenty feet from the surface of the ground. There is abundance of stone in the adjacent hills, and there is also plenty of earth and clay in the valley for our purposes, but it is doubtful whether the clay is sufficiently retentive to keep out the water. Shafts were sunk through the earth and clay twenty feet deep, but was found impossible to keep them dry by mere ordinary baling.

The bed of the river at the site of the Shewla Dam is rock, but the hills on the sides have not a solid appearance on the surface. They are, moreover, so low, that they give one the impression of having been worn away in consequence of the softness of the material of which they are composed. There is abundance of paddy-field clay, but none of any other kind has been observed by me. The height of the dam, 96 feet, as proposed by Mr. Aitken, would, however, render it advisable not to run the risk of an earthen construction.

The Tansa river runs on a bed of solid rock, which is exposed to view almost everywhere along its course, but is very plainly visible at the site of the dam, where the surface is as smooth as a floor. The very character of the gap through which the river passes, tells us that the strata must be rock. On one side the bank rises so abruptly, that it is difficult to climb it, and on the other side also there is every indication of solid rock. If the strata had been soft, the river, instead of running through a narrow channel, would probably have washed away a great part of the valley. The rock, in fact, has held the river in its hand, and defies it even now to wander at all from its present course. It is almost absurd of me to say that there is abundance of the best stone for building purposes: excepting a superficial deposit of moorum and boulders, there is literally nothing else. The whole country is stone. Material of the first quality might be quarried almost in any spot taken at hap-hazard near the dam. On the other hand, the only clay there is, would have to be brought from paddy fields, two miles away from the spot.

Let me add to all this the advantage of masonry over earthen dams, pointed out by Mr. Ormiston, and in which I cordially agree with him:—

“If masonry dams are properly constructed, they are more satisfactory than earthen dams: a leak in the one is only so much loss of water, in the other it may be destruction.”*

This point is well put, and is worthy of the greatest consideration by the people of Bombay.

Let me now sum up the case of masonry against earthen dams.

We are warned by those who have a great claim to be heard on the subject, that dams of earth over 65 feet in height are “things of chance.”

* *Vide* his “Memorandum” on the Toolsee Scheme. On this important point, I am glad indeed to be able to quote Mr. Ormiston, an Engineer of such great experience, and in whose judgment, the Bench, and rightly so, place much confidence.

Our greatest English authority limits us to 100 or to 120 feet only. There is no good clay in the country. There is abundance of the best rock. All our sites are better suited to masonry than to earth. None of our dams would be lower than the limit of safety laid down by the French. Two, Kamun and Tansa, would reach the limit suggested by Mr. Rankine. Two, Kennery and Ewoor, would exceed even this limit. Lastly, earthen dams with leaks are liable to destruction, sometimes to a very sudden one, causing immense loss of life and property, whereas masonry dams with leaks are always safe against sudden destruction, and never liable to be washed away bodily at all.

Thus then it will be seen, I trust, that the case of earthen dams when inquired into breaks down lamentably.

On all the above considerations, and bearing in mind that the well-being of a population approaching three-quarters of a million in number is concerned, the public, with the examples of the Vehar Dams before them, will no doubt agree with me that the town should set its face against works involving danger or even insecurity, and should insist on that class of work being carried out, which will relieve them of their present anxiety, and be as little a source of anxiety to them as possible even in the future.

APPENDIX A.

From—The Executive Engineer, Municipality.

To—Professor W. J. M. Rankine, University, Glasgow.

SIR,—For some years I have had a conviction that the mode of constructing high embankments for the purpose of impounding water usually adopted by the profession is faulty. I consider the fact of the puddle wall in the middle of the dam being virtually all the resistance that the dam can bring to bear against the water, renders all our dams far too weak. My mind has been led on to the subject of masonry dams, and the best mode of constructing them. A few months ago I accidentally came across the work which you will receive along with this letter.* I do not know whether you have ever read the papers contained in it, but I have no doubt that they will prove very interesting to you. You will there see that while England possesses hardly a single dam which is

* Colonel Fife's pamphlet on "Dams of Masonry."

considered perfectly safe with a pressure of 100 feet, the French have constructed one, and with the greatest success, 165 feet high. Not a drop of water escapes from this masonry work. The principles on which the Furens dam is constructed are fully explained in the book. I was very much struck with the work, but I am still not disposed to abandon an idea which I have all along had regarding the construction of dams.

In the building of the Furens dam, three points were considered. The dam might slide, the dam might be overturned, and it might yield by the compression of its own weight. No case of a dam having ever slid is on record. The tendency to failure in this respect, especially if the wall is of uncoursed rubble, is so small that it was discarded in the calculations. Again, no dam has ever been overturned. Every dam, in fact, has been strong enough to resist the mere pressure of the water. To make a wall, therefore, to stand against a certain head of water, disregarding other considerations, is a simple enough problem. Lastly, every dam has given way by its own compressing force, and the French Engineers, as I understand them, say that, having provided a certain thickness of wall to resist the mere pressure of the water, the best and cheapest distribution of the material would be that in which the weight was evenly and equally distributed throughout. Beyond all doubt, in my humble opinion, they have constructed a work which, considered either in its scientific or æsthetic aspect, has put into the shade all works of a similar nature ever before constructed. But, in spite of this, I think a still more effective disposal of the material with a less quantity may be made, and one which to the eye will present as pleasing and as imposing an aspect.

My idea is this, that up to that height of the dam below which the water is not intended to sink, the embankment should lean as it were against the water. Of course I see the objection which French Engineers would make, that in this case we add very much to the weight to be borne by the inner portion of the wall, causing it to slip downwards; but still we surely cannot reach anything like the point of compression by adopting this method for dams of the ordinary heights. They would not be likely to slip. There can be no doubt that we should be able to make a great saving in material, for the power of a dam (constructed as I propose) to resist the pressure of the water to overturn it would be considerably increased. As the problem to be rigorously calculated requires the higher methods of mathematical analysis, I have applied and obtained the per-

mission of the Municipal Commissioner of this town to submit it to you. What I should like is a rigorous mathematical solution, and after this the practical effect of the proposition. I may be quite wrong, but Mr. Crawford is of opinion, that the highest authority should be consulted on so important a subject, which involves the saving of thousands of pounds.

I send you a plan showing the Furens dam, and approximately the section which I would propose to give, *vide Plate VIII*.

We should feel obliged if you would have a section of the best form of dam drawn out, according to your calculations, both for short and long dams. The French Engineers propose, as I understand them, the same *form* for dams of all heights, so that, taking the Furens dam at 165 feet high, the best form for a dam 100 feet high would be simply to take the Furens section for the upper hundred feet. Perhaps one uniform section may not be possible according to your calculations, in which case a sketch showing dimensions of all dams, from say 50 to 165 feet (by tens of feet), would be very convenient.

I should inform you that the materials for which the dams should be calculated are rubble masonry, made with a fairly hydraulic (natural) lime and hard trap rock, the resistance of which rock to crushing, and the weight of which might be taken the same as for granite.

We should also desire your opinion as to whether coursed or rubble masonry would be the best on all accounts. Of course you will see my object is to reduce the mass of masonry as much as I can, and I endeavour to do so by throwing the centre of gravity of the dam as far forward (towards the water side I mean) as possible, and thus immensely strengthening the dam's resistance to the power of the water to overturn it. My object, moreover, in giving the upper portion of the dam a reverse slope is to throw its weight back as much as possible, and thus to relieve the front of the wall from as much compressing force as I can. This portion of the dam is not *always* subjected to the pressure of water, but may or may not be according as the reservoir is full up to its intended height or empty.

The section which I have drawn, as an illustration of my idea, I need hardly say, has not been calculated out. It is of no particular dimensions, and merely a rough illustration of what is intended.

Any remarks which you might like to make on the French Engineer's papers would be very acceptable.

H. T.

APPENDIX B.

*Report on the Design and Construction of Masonry Dams.***By Professor W. J. M. Rankine, C.E., &c.*

1. I have carefully considered the letter of Captain Tulloch, R.E., Exec. Engineer of the Municipality of Bombay, dated the 10th December, 1870, on the subject of Masonry Dams or Reservoir Walls of great height, and also the papers on the same subject by M. Graeff and by M. Delocre, which appeared in the "Annales des Ponts et Chaussées." These last I have studied, both in the original, and in the very faithful translation by Col. J. G. Fife. I have also made mathematical investigations as to the proper figure and dimensions of such dams, which are given in Appendix C.

2. As regards the material best suited for a Reservoir Wall or embankment, I consider that it must be determined by the nature of the foundation. That foundation should be sound rock, if practicable, and should a rock foundation be unattainable, firm impervious earth. It may be doubted whether any earthen foundation is thoroughly to be relied on where the depth of water exceeds 100 or 120 feet. It is not advisable to build a masonry dam on an earthen foundation; for the base of the dam must be spread to a width sufficient to distribute the pressure, so that it shall not be more intense than the earthen foundation can bear; and this involves the use of a quantity of material which would lead to immoderate expense if the material used were masonry.

3. In the case of a rock foundation, the proper material is unquestionably rubble masonry, laid in hydraulic mortar; and the opinion of M. Graeff, that continuous courses in building that masonry are to be avoided, is fully corroborated by experience; for the bed-joints of such courses tend to become channels for the leakage of the water.

4. The very fact, however, of the irregular structure of that masonry, renders necessary unusual care and vigilance in superintending its erection, in order to insure that every stone shall be thoroughly and firmly bedded, and that there shall be no empty hollows in the interior of the wall, nor spaces filled with mortar alone where stones ought to be placed. The practice of "grouting," or filling hollows by pouring in liquid mortar should be strictly prohibited.

* *Plate IX.* is a copy of Mr. Rankine's Proposed Dam. *Plate VIII.* gives some useful information regarding dams.

5. With respect to the profile of the wall, its figure is in the main to be determined by principles nearly the same with those laid down by the French Engineers already referred to, and put in practice in the dams of the rivers Furens and Ban, that is to say, the intensity of the vertical pressure at the inner face of the wall, should at no point exceed a certain limit, when the reservoir is empty; and the intensity of the vertical pressure at the outer face of the wall should at no point exceed a certain limit when the reservoir is full.

6. In the theoretical investigations of M. Delocre and the practical examples given by M. Graeff, the same limit is assigned to the intensity of the vertical pressure at both faces of the wall. But it appears to me that there are the following reasons for adopting a lower limit at the outer, than at the inner face. The direction in which the pressure is exerted amongst the particles close to either face of the masonry, is necessarily that of a tangent to that face; and, unless the face is vertical, the vertical pressure, found by means of the ordinary formulæ is not the whole pressure, but only its vertical component; and the whole pressure exceeds the vertical pressure in a ratio which becomes the greater, the greater the "batter," or deviation of the face from the vertical. The outer face of the wall has a much greater batter than the inner face; therefore, in order that the masonry of the outer face may not be more severely strained when the reservoir is full, than that of the inner face when the reservoir is empty, a lower limit must be taken for the intensity of the vertical pressure at the outer face, than at the inner face.

7. The proposal of the Executive Engineer, to throw the weight of the wall further inwards than in the French designs, tends to realize the principle just stated; and so far I fully approve of it, and have carried it out in the profile which accompanies this report.

8. I do not, however, concur with the Executive Engineer in the proposal to throw the weight of the wall so far inwards as to make it overhang, for the following reason: the additional stability against the horizontal thrust of the water, gained by giving the wall an overhanging batter inwards, is not that due to the whole weight of the overhanging masonry, but only to the excess of that weight above the weight of water which it displaces; in other words, about half the effect of the weight of the overhanging mass of masonry in giving stability is lost through its buoyancy; and hence the additional stability gained by making the wall

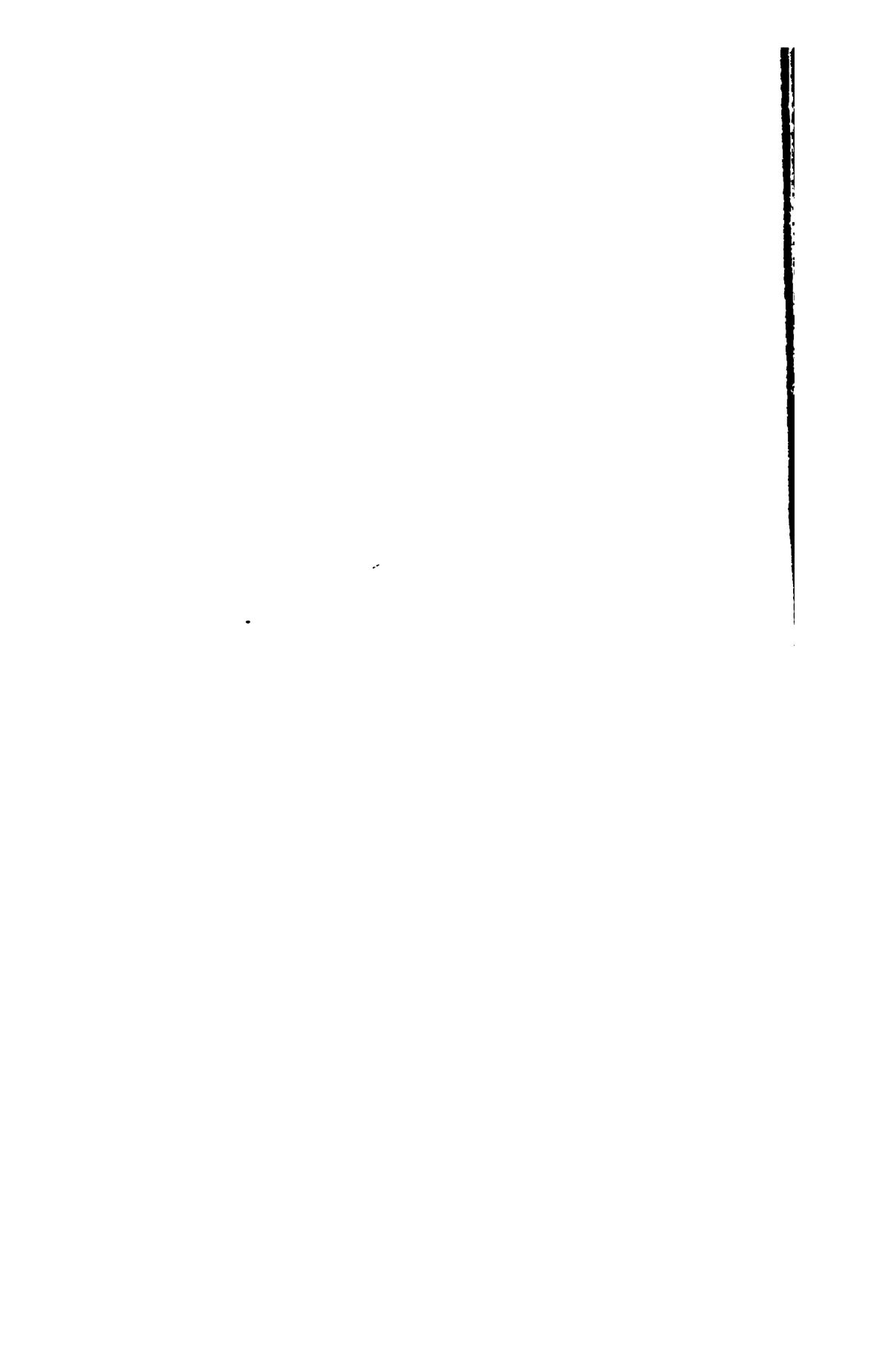



overhang inwards, is not proportionate to the additional load thrown upon the lower parts of the inner face; and more stability would be gained by placing a given mass of masonry, so as to form an uniform addition to the thickness of the wall, than by making it overhang inwards.

9. In choosing limits for the intensity of the vertical pressure at the inner and outer faces of the wall represented by the accompanying profile, I have not attempted to deduce the ratio which those quantities ought to bear to each other from theory of the distribution of stress in a solid body; for the data on which any such theoretical determination would have to be based are too uncertain. The limits which I have chosen, are as follows, and they are given in the first place, in feet of a vertical column of masonry, whose weight would be equivalent to the pressure; and are then reduced to various other measures:—

Limits of Vertical Pressure at	Inner face.	Outer face.
Feet of Masonry,	160	125
" Water,	320	250
Lbs. on the square foot (nearly), ..	20,000	15,625
Mètres of Masonry (nearly), ..	49	88
" Water (nearly),	98	76
Kilog. on the square centimètre (nearly),	9·8	7·6

In choosing these two limits, I have been guided by the consideration of the following facts. As regards the inner face, where the deviation of the direction of the stress from the vertical is unimportant, it is certain, from practical experience, that rubble masonry, laid in strong hydraulic mortar and good rock foundations, will safely bear a vertical pressure equivalent to the weight of a column of masonry 160 feet high, if not higher. As regards the outer face, the practical data given by M. Graeff show that masonry of the same quality, in the sloping outer face of a dam, will safely bear a pressure whose vertical component, as found by the ordinary rules, is equivalent to the weight of a column 125 feet high.

10. The same reasons which show that the intensity of the vertical components of the pressure ought to be less for a battering than for a vertical face, show also that this intensity ought gradually to diminish at the lower part of the outer face, where the batter gradually increases. In the present state of our knowledge, we should not be warranted in framing any definite theory as to the law which this diminution ought to follow; and, therefore, in preparing the accompanying design, I have thought it best to be guided in this, as in the previous case, by practical examples, and to

consider it sufficient to make the law of diminution such, that at the depth of 150 feet below the surface, the intensity of the vertical component of the pressure at the outer face becomes nearly equal to what it is at the same depth in the outer face of the dam across the Furens—viz., 107 feet of masonry, or about $6\frac{1}{2}$ kilogrammes on the square centimètre.

11. I have kept in view another principle, not referred to by the French authors—viz., that there ought to be no practically appreciable tension at any point of the masonry, whether at the outer face when the reservoir is empty, or at the inner face when the reservoir is full. Experience has shown that in structures of brickwork and masonry that are exposed to the overturning action of forces, which fluctuate in amount and direction (as when a factory chimney is exposed to the pressure of the wind), the tendency to give way first shows itself at that point at which the tension is greatest. In order that this principle may be fulfilled, the line of resistance should not deviate from the middle of the thickness of the wall, to an extent materially exceeding one-sixth of the thickness. In other words, the lines of resistance when the reservoir is empty and full, respectively, should both lie within, or but a small distance beyond, the middle third of the thickness of the wall.

12. As regards the effect of giving the wall a curvature in plan, convex towards the reservoir, I look upon this as a desirable, and in many cases an essential precaution, in order to prevent the wall from being bent by the pressure of the water into a curved shape, concave towards the water, and thus having its outer face brought into a state of tension horizontally, which would probably cause the formation of vertical fissures, and perhaps lead to the destruction of the dam. I consider, however, that calculations of stability which treat the dam as a horizontal arch are so uncertain as to be of very doubtful utility; and I would not rely upon them in designing the profile. In fixing the radius of horizontal curvature, I consider that the Engineer should be guided by the form of the gorge, in which the dam is to be built, making that radius as short as may be consistent with convenience in execution, and with making the ends of the dam abut normally against the sound rock at the sides of the gorge.

13. The conditions which have been observed in designing the accompanying profile, may be summed up as follows:—

A. The vertical pressure at the inner face not to exceed 160 feet of masonry;

- B. The vertical pressure at the outer face not to exceed 125 feet of masonry at the point where it is most intense, and to diminish in going down from that point;
- C. The lines of resistance when the reservoir is full and empty, respectively, to be within, or near to the middle third of the thickness of the wall. These are limiting conditions, and do not prescribe exactly any definite form.

In choosing a form in order to fulfil them without any practically important excess in the expenditure of material beyond what is necessary, I have been guided by the consideration, that a form whose dimensions, sectional area, and centre of gravity, under different circumstances, are found by short and simple calculations, is to be preferred to one of a more complex kind, when their merits in other respects are equal; and I have chosen logarithmic curves for both the inner and the outer faces.

14. The constant subtangent common to both curves (marked AD in the drawing) is 80 feet; this bears relations to the vertical pressures which are stated in the Appendix.

The thickness CB at 120 feet below the top is 84 feet; and of this one-fourteenth, AC = 6 feet, lies inside the vertical axis OX, and thirteen-fourteenths, AB, 78 feet, outside that axis. The formula for the thickness t at any depth x , below the top, is as follows:—

$$t = t_1 \cdot e^{\frac{x - x_1}{a}} \dots\dots\dots(1),$$

or in common logarithms

$$\log t = \log t_1 + 0.4343 \frac{x - x_1}{a} \dots\dots\dots (1A),$$

in which a denotes the subtangent (80 feet), and t_1 the given thickness (84 feet) at the given depth (120 feet) below the top. The thickness at the top is 18.74 feet.

15. In the profile, horizontal ordinates are drawn at every 10 feet of depth from the top down to 180 feet, and their lengths, from the vertical axis OX to the inner faces, respectively, are marked in feet and decimals. In each case those ordinates are, respectively, one-fourteenth and thirteen-fourteenths of the thickness. Intermediate ordinates at intervals of 5 feet can easily be calculated, if required, by taking mean proportionals between the adjacent pairs of ordinates at intervals of 10 feet.

16. The sectional area of the wall from the top down to any given depth, is found by multiplying the constant subtangent ($a = 80$ feet) by

the difference ($t - t_0$) between the thickness at the top, and at the given depth; that is to say

$$\int_0^x t \, dx = a (t - t_0) \dots \dots \dots (2).$$

17. The vertical line through the centre of gravity of the part of the wall above a given horizontal plane, stands midway between the middle of the thickness at the given horizontal plane, and the middle of the thickness at the top of the wall; and thus have been found points in the curve marked "Line of Resistance, Reservoir Empty."

18. Supposing the reservoir filled to the level of the top of the wall, the moment of the pressure exerted horizontally by the water against each unit of length of wall from the top down to a given depth (x) is found by multiplying the weight of a cubic unit of water by one-sixth of the cube of the depth; and if we take, for convenience, the weight of a cubic unit of masonry as the unit of weight, and suppose the masonry to have twice the heaviness of water, this gives us, for the moment of horizontal pressure,

$$M = \frac{x^3}{12} \dots \dots \dots (3).$$

19. The moment of horizontal pressure, expressed as above stated, being divided by the area of cross-section above the given depth, gives the horizontal distance at the given depth between the lines of resistance with the reservoir empty, and full, respectively; that is to say

$$\frac{M}{\int t \, dx} = \frac{x^3}{12 a (t - t_0)} \dots \dots \dots (4).$$

and thus have been found points in the curve marked "Line of Resistance, Reservoir Full."

20. In the preceding formulæ, the pressure of the water against the inner face of the wall is treated as if it were wholly horizontal (as in the investigations of M. Graeff and M. Delocre). In fact, however, that pressure, being normal to the inner face of the wall, has a small inclination downwards; and, therefore, contains a small vertical component, which adds to the stability of the wall. The neglect of that vertical component is an error on the safe side.

21. To find the mean intensity of the vertical pressure on a given horizontal plane in the masonry, expressed in feet of masonry, divide the sectional area by the thickness at the given plane; that is to say

$$\int \frac{t \, dx}{t} = a \left(1 - \frac{t_0}{t} \right) \dots\dots\dots (5).$$

To find the greatest intensity of that vertical pressure according to the ordinary assumption that, it is an *uniformly varying stress*, in other words, that it increases at an uniform rate from the face furthest from the line of resistance, to the face nearest to that line, the mean intensity is to be increased by a fraction of itself expressed by the ratio which the deviation of the line of resistance from the middle of the thickness bears to one-sixth of the thickness; that is to say, let *p* denote that greatest intensity, expressed in feet of masonry, and *r* the deviation of the line of resistance from the middle of the thickness; then

$$p = a \left(1 - \frac{t_0}{t} \right) \left(1 + \frac{6r}{t} \right) \dots\dots\dots (6).$$

When that deviation is appreciably greater than one-sixth of the thickness, the preceding rule is no longer applicable, but this case, as already explained, ought not to occur in a reservoir wall.

The assumption on which the rule is based, of an uniform rate of variation of that component of the pressure which is normal to the pressed surface, is known to be sensibly correct in the case of beams, and is probably very near the truth in walls of uniform or nearly uniform thickness. Whether, or to what extent, it deviates from exactness in walls of varying thickness, is uncertain in the present state of our experimental knowledge.

22. The range of different depths to which the same profile is applicable without any waste of material, extends from the greatest depth shown on the drawing, 180 feet, up to 110 feet, or thereabouts. For depths between 110 feet and 80 or 90 feet or thereabouts, the waste of material is unimportant. For depths to any considerable extent less than 90 feet, the use of a part of the same profile gives a surplus of stability. For example, if the depth be 50 feet, the quantity of material is greater than that which is necessary in the ratio of 1.4 to 1, nearly. For the shallow parts, however, at the end of a dam that is deep in the centre, I think it preferable to use the same profile as in the deep parts, notwithstanding this expenditure of material, in order that the full advantage of the abutment against the sides of the ravine may be obtained. In the case of a dam that is less deep in the centre than 110 feet, the following rule may be employed: Construct a profile similar to that suited to a depth of 110 feet, with all the thicknesses and ordinates diminished in the same pro-

portion with the depth. The intensity of the vertical pressure at each point will be diminished in the same proportion also ; but this does not imply waste of material ; the whole weight of the material being required, in order that there may be no appreciable tension in any part of the wall.

W. J. M. R.

APPENDIX C.

MATHEMATICAL PRINCIPLES OF THE PROFILE CURVES. *By Professor W. J. M. Rankine, C.E., &c.*

I.—*Principles relating to all forms of Profile.*

Let t , as before, be the thickness of the wall in a horizontal plane at the depth x below the top ; then taking the weight of a cubic unit of masonry as the unit of weight, the weight of each unit of length of the wall above that plane is expressed by

$$\int_0^x t \, dx$$

In order that there may be no appreciable tension at the outer edge of the given plane when the reservoir is empty, nor at the inner edge when it is full, the centre of resistance of that plane ought not to deviate from the middle of the thickness by more than about one-sixth of the thickness ; inwards when the reservoir is empty, outwards when it is full.

Let y denote the deviation of the centre line of the thickness of the wall outwards from a vertical axis OX ; so that $y - \frac{t}{2}$ and $y + \frac{t}{2}$ are the ordinates of the inner and outer faces of the wall, respectively ; and when $x = 0$, let $y = y_0$.

The line of resistance when the reservoir is empty, cuts the horizontal plane at the depth x in a point vertically below the centre of gravity of the part of the wall above that plane ; and in order that the weight of the wall may be thrown as far inwards as is consistent with there being no appreciable tension at the outer face when the reservoir is empty, the deviation of that line of resistance from the middle of the thickness of the wall ought not materially to exceed one-sixth of the thickness ; hence, if r' be taken to denote the inward deviation in question

$$r' = y - \frac{\int_0^x y t \, dx}{\int_0^x t \, dx} = \text{or } < \frac{t}{6} \text{ nearly..... (A).}$$

Let w be the ratio in which the masonry is heavier than water. Then the moment of the horizontal pressure of the water above the same plane on each unit of length of wall is

$$M = \frac{x^3}{6w}$$

The vertical component of that pressure is neglected, as explained in the body of the report. The extent to which the centre of resistance at the given horizontal plane is shifted outwards by the pressure of the water is,

$$r' + r = \frac{M}{\int_0^x t \, dx} = \frac{\frac{x^3}{6w}}{\int_0^x t \, dx} \dots\dots\dots (B).$$

in which r denotes the outward deviation of the line of resistance from the middle of the thickness when the reservoir is full, and the condition that the centre of resistance when the reservoir is full is not to deviate from the middle of the thickness by more than about one-sixth of the thickness, is expressed by the following formulæ, in which r denotes the outward deviation.

$$r = \frac{\frac{x^2}{6w} + \int_0^x y t \, dx}{\int_0^x t \, dx} - y = \text{or} < \frac{t}{6} \text{ nearly} \dots\dots (C).$$

The formulæ A and C express the condition that there shall be no practically important tension in the masonry at any horizontal plane.

Let p' and p be the vertical pressures at the inner and outer faces, respectively, at the depth x ; and P' and P the limits which those pressures are not to exceed. Then we have as another pair of equations to be satisfied

$$p' = \left(1 + \frac{6r'}{t}\right) \frac{\int_0^x t \, dx}{t} = \text{or} < P' \dots\dots\dots (D).$$

$$p = \left(1 + \frac{6r}{t}\right) \frac{\int_0^x t \, dx}{t} = \text{or} < P \dots\dots\dots (E).$$

II.—Principles relating to the Logarithmic Curve Profile.

As a means of satisfying the equations of condition to a degree of approximation sufficient for practical purposes, let the inner and outer boundaries of the profile be all three logarithmic curves with the vertical axis OX for their common asymptote, and having one common constant subtangent a . It may be remarked that one reason for adopting the logarithmic

curve is its giving a thickness at the top of the wall sufficient for the formation of a roadway; and that another reason is, its giving values to the intensity of the pressure at the outer face below the point of maximum pressure, which diminish as the latter increases. Let the ratio borne by the deviation y of the centre line of the thickness from the vertical axis to the thickness t be expressed by

$$o = \frac{y}{t}$$

Then we have the following equations :—

$$t = t_0 e^{\frac{x}{a}} \dots\dots\dots (F).$$

$$y = o t = c t_0 e^{\frac{x}{a}} \dots\dots\dots (G).$$

$$\int_0^x t dx = a t_0 (e^{\frac{x}{a}} - 1) = a (t - t_0), \dots\dots\dots (H).$$

$$r' = \frac{ct_0}{2} (e^{\frac{x}{a}} - 1) = c \frac{t - t_0}{2} = \frac{y - y_0}{2} \dots\dots\dots (K).$$

$$r = \frac{x^2}{6 w a (t - t_0)} - \frac{c (t - t_0)}{2} = \frac{x^2}{6 w a t_0 (e^{\frac{x}{a}} - 1)} - \frac{ct_0}{2} (e^{\frac{x}{a}} - 1)(L).$$

$$p' = a \left(1 - e^{-\frac{x}{a}} \right) \left\{ 1 + 3 c \left(1 - e^{-\frac{x}{a}} \right) \right\} \dots\dots\dots (M).$$

$$p = a \left\{ 1 - e^{-\frac{x}{a}} - 3 c \left(1 - e^{-\frac{x}{a}} \right)^2 \right\} + \frac{x^2 e^{-\frac{2x}{a}}}{w t_0^2} \dots\dots\dots (N).$$

When the values given above are substituted in the expressions of conditions, A, C, D, and E, the formulæ obtained are of a kind incapable of solution by any direct process. They can, however, be solved approximately without much difficulty by the process of trial and error; and such is the method by which the dimensions of the profile sent with the report have been obtained; the constants employed being $w = 2$; $P' = 160$ feet; $P = 125$ feet. The general nature of the process of approximation followed may be summed up as follows. By making $\frac{dp}{dx} = 0$, an equation is obtained involving the value of $\frac{x}{a}$ which makes p a maximum. That equation shows that as a first approximation to that value we may take $\frac{3}{2}$. This first approximation is inserted in equation K; and by

making $r' = \frac{t}{6}$ there is deduced from the equation an approximate value of c . Then, in equation M, by inserting the approximate values of $\frac{x}{a}$ and of c , and making $p' = P$ (the limit of p), there is obtained an approximate value of a ; and by making $r = \frac{t}{6}$ in equation L, an approximate value of t . The several first approximate values being then inserted in $\frac{dp}{dx} = 0$, there is obtained a correct value of $\frac{x}{a}$, which is found to be about $\frac{11}{8}$; and thence, by means of equation N, the actual maximum value of p is computed, and found to fall slightly within the prescribed limit. Finally, as a test of the approximations, equations K, L, M, and N are applied to a series of values of x extending from the top to the bottom of the wall. As to the degree of approximation obtained, the greatest values of p' and p are, respectively, 154 and 124 feet, instead of 160 and 125 feet; and there are, as the drawing shows, some small deviations of the lines of resistance beyond the middle third of the thickness; but not sufficient to be of practical importance.

The following table contains some additional values of the vertical pressure at the outer face, at and near the point where it is more intense:—

Depths,	feet;	90	100	110	120	130.
Vertical pressures,	„	114	122	124	122	117.

W. J. M. B.

 No. LXIX.

 REPORT ON RATES OF WORK IN BERAR.

 BY MR. R. G. ELWES, *Asst. Secy. P. W. Department, Hyderabad.*

The causes which tend to make rates of work higher in Berar than elsewhere may be divided under three heads :—

I.—Peculiarities of soil and climate.

II.—Cost of imported materials.

III.—Cost of labor.

I.—Peculiarities of soil and climate.

Berar is particularly unfortunate in being almost destitute of brick-earth, potters' clay, lime stone, and timber.

The soil is generally "regur," or what is called "black cotton soil." Under this lies either trap rock, mostly basaltic, or "moorum," a kind of gravel believed to be the result of the decomposition of trap. True clay, whether pure and plastic, or in the form more suitable for bricks, scarcely exists throughout the Province. The substitutes which the natives use are the slimy mud which collects at the bottom of ponds and tanks, and "pandree mittee," a whitish earth of argillaceous appearance which is found mainly on the sites of villages, and is probably a mixture of the tank mud from which the houses were originally built, with the sweepings and refuse of ages. It contains much organic matter and salts, and is unfit for brickmaking.

This absence of clay contributes very greatly to the costliness of buildings in Berar. A large class of structures, such as police stations, jails, quarters for native establishments, inclosure walls, out-offices, interior

walls to larger buildings, &c., &c., which are elsewhere built with mud, or with sundried bricks set in mud mortar, have here to be constructed of far more expensive materials.

The next cheapest style of work, common in other districts, consists of burnt bricks set in mud mortar. But even if the porous and friable bricks alone obtainable in Berar, which are sometimes so bad as actually to float in water when first immersed, could be used in this way, the cementing material, clay, is wanting. The mud to be procured will not stand the washing of the heavy monsoons, nor the occasional leakage from above which would not injure a better clay. Attempts have been made to use stone set in mud mortar for post offices, police stations, and other minor buildings, but the above defect, with the peculiarities of the stone, to be hereafter described, have caused the rapid and general failure of these buildings which are now being re-placed at much expense with more durable materials. The use of stone in mud mortar, such as is alone procurable, has been clearly shown by extensive experience to be false economy in Berar, unless in exceptional circumstances.

The want of potters' clay also causes serious expense in the matter of roofs.

The tiles, obtainable in small quantities only, are so inferior, and from the high price of fuel, so expensive, that the use of tiled roofs is becoming more and more doubtful in economy, while the impossibility of preventing leakage from the porosity and fragility of the tiles, and the expense and annoyance of continual repairs, are sources of much complaint.

Flat terrace roofs, as will be seen further on, are very costly; flat mud roofs as commonly used in the North-West will not stand, from the nature of the mud; and in short it may be said that there is no such thing as a cheap satisfactory roof in Berar, except thatch, which of course is inadmissible from its inflammability.

Except two local deposits, neither of which are generally available for the operations of the department, there is no good lime stone in Berar. We are mainly dependent for lime upon kunkur, and deposits of a similar nature, approaching more nearly to limestone than the ordinary kunkur of the North-West. Some of these deposits yield an excellent lime, but they are capriciously distributed and scarce. The cost of fuel is also very high; the scrub and larger jungle which once covered large tracts have

almost disappeared from the Berar valley. Firewood and charcoal have to be brought from long distances; in many cases from tracts under Forest Rules, where the tax levied, though perhaps not large in itself, falls heavily on the departmental operations from the considerable quantities consumed. Thus the cost of fuel, and the distances from which it has often to be carted, tend to increase the expense of all works into which tiles, lime, or iron enter as materials.

In addition to the cost of fuel, the absence of larger timber is an important element in the cost of works in Berar. Timber is so scarce that even for domestic and private use, inferior timber is brought from Bombay and sold in the larger bazars by private merchants. For all those minor purposes for which most districts in India supply local timber, it is necessary to import wood from Bombay; and the difference in price between teak and the inferior kinds obtainable there is not sufficient (except in a few special cases) to compensate by the saving for the loss of superior qualities in the former. When every rafter and doorpost has to be brought by rail from Bombay, and afterwards carted 50, 60 or even 80 miles, it may easily be conceived how the cost of woodwork runs up.

Having now mentioned some of the negative peculiarities which enhance prices in Berar, some positive disqualifications, arising out of the soil and climate, require notice. In the first place the Province is but sparsely provided with metalled roads, and wherever these are not, the black soil becomes an impassable quagmire from June to the beginning of October. During another period, from about December till April the carts of the country are occupied in taking cotton to market, and thus it is only at limited periods that carriage is available in quantity. But the operations of the department cannot be confined to these restricted periods; hence the cost of carriage is increased by the competition of cotton sellers, and this affects more or less, in the conveyance of materials, every work undertaken. The cost of carriage will be further noticed under the head of labor.

Another disadvantage under which Berar suffers, is the unsuitability of the only stone generally procurable, for building purposes. It is a hard intractable basalt, which has no regular cleavage, and a highly irregular, often conchoidal, fracture. It is very liable to split, but from the absence of cleavage this makes it all the more difficult to dress into any regular shape. An attempt at a class of work better than random rubble, ends in

most expensive block-in-course, or else the notorious "breadseal" work, of which a full description will be found in the Roorkee Professional Papers, [New Series, No. XVIII.] The paper referred to explains clearly the difficulties of executing masonry in a trap country, and a perusal of it will throw much light on the costliness of work in Berar.

The nature of the rock makes it both difficult and expensive to introduce a proper proportion of bond-stones; while the want of adhesion of mortar to basalt, the want of porosity in the stone, and the great heat and dryness of Berar, cause a two-fold increase of expense, in the extra massiveness required for safety, and the necessity of long continued watering to prevent the mortar crumbling into a dry powder before it has time to set.

The details given above will explain why it is necessary so largely to use imported materials in Berar. These consist chiefly of teak, and iron in various forms, and their unavoidable costliness is the second main element in the high rates of Berar, noted in page 96.

The cost of carriage, the waste in conversion, and the expense of sawyer's labor, make it advisable as a rule to purchase teak in Bombay ready sawn to the required scantlings. The rate paid is usually about Rs. 2½ to 3 per cubic foot. The cost of Railway carriage for ordinary lengths to Akola is about Rs. 0-13-3 per cubic foot, and to Oomraotee, Rs. 0-15-4. If more than 120 cubic feet are sent in one consignment the rates are somewhat less. Should the length however exceed 20 feet the charge is considerably increased. For such timbers the Railway Company's Rules require that two wagons be paid for at a minimum charge for 3 tons, or 120 cubic feet each. It would seldom happen that the actual weight of timber carried would amount to this; the effect therefore is to lay a varying and it may be excessive charge per cubic foot on the timber carried. The department has no control over charges of this kind; but it appears inexpedient that the Railway Company should impose prohibitory rates. Under the present system cases might easily occur in which it would be cheaper to cart timber the whole way from Bombay than to send it by rail. In fact, at this moment timber is being carted all the way from the Madras coast to Secunderabad, instead of bringing it up by rail, as the former plan is found cheaper.

In ordinary cases, however, sawn teak costs delivered at Akola about Rs. 3-6 to 3-14 a foot, and at Oomraotee, Rs. 3-8 to 4. The waste in framing, and the cost of carpenters' labor in framing and erecting, with

carriage to site, bring up the final cost to the prevailing rates of Rs. 5-8 to 6-8 per cubic foot. These are doubtless very high, but it is not clear how they can be reduced.

The cost of wrought-iron in Bombay is about as follows :—

Bars	Rs. 6 to 8 per cwt.
Girders	" 12 "
Trusses	" 18 "

The necessity of working up the iron with rude appliances and unskilled smiths, compels the purchase of expensive brands, as they are the most easily worked.

Cast-iron costs in Bombay Rs. 6 to 8 per cwt. for ordinary castings. The cost of carriage to Akola is Rs. 1-3-3 per maund, and to Oomraotee, Rs. 1-6-3, and for castings erected at stations on the line of rail the rate is about Rs. 12 per cwt.

The rate for wrought-iron erected and fixed in framework of roofs and similar work is about Rs. 25 per cwt.

A great part of the cost lies in the working up of the iron on the spot (due partly to cost of fuel mentioned above, partly to cost of labor,) and in the carriage to site.

The carriage of castings is expensive owing to their weight. Indeed there are few situations off the line of Railway, in which cast-iron can be used to advantage.

For reasons given above, tiled roofs are not suitable for buildings of any importance in Berar. Terraced flat roofs are objectionable from the inferiority of the bricks and tiles of the district, and costly, from their weight requiring strong walls, and massive beams of expensive teak. The advantages of corrugated iron have led to its being largely used in Berar; but it is not a cheap roof. The covering itself costs about Rs. 50 per 100 square feet. It has the advantage of requiring only a light framing; and, indeed, in small buildings, no frame at all. But it is necessary for coolness to provide a ceiling, and the experiments which have been made with plaster ceilings on the English plan, substituting split bamboos for laths, have not been altogether satisfactory. At present a planked ceiling of pine appears the best; this costs about Rs. 18 per 100 square feet.

The third cause of the high rates in Berar, and one which enters into nearly every item of our estimates, is the cost of labor.

This affects not only the "labor" rate so called, but also the cost of all our local materials; for in fact the price of these commonly represents

little more than the labor expended in procuring them. The rent of quarries and such charges form but an insignificant portion of the cost of materials delivered, except perhaps in the case of timber, where the price of the standing tree forms an exception to the rule.

The high rates in Berar attracted attention as far back as 1862, when Captain Tyrrell, then Executive Engineer, Berar Division, reported in reply to remonstrances as to the cost of his works, to the following effect:— When he arrived in Berar in 1857 he found the wages of masons or bricklayers to be about 4 annas per diem, but they were so few in number and so unskilled that he was obliged to import workmen from Hyderabad and Nagpore. To induce these men to leave their homes, it was necessary to offer high wages, 6 or 7 annas per day. There were, according to Captain Tyrrell, no ordinary laborers to be had, as the “Dhers” or low caste village servants, could earn enough in a lazy way about the villages to satisfy them, and coolies also had to be imported.

Carts were but little used in Berar, on account of the nature of the deep black cotton soil. The few that existed were required for agricultural purposes. Numbers of carts were sent into Berar from Bombay or from other districts under engagements to cart cotton down, for which fancy prices were paid, and the rate of cart hire thus became abnormally high.

Brick earth scarcely exists in Berar, and Captain Tyrrell states that the Railway Company although they had experienced English brick makers, lost 50 or 60 lakhs of bricks in the vain endeavour to turn out a serviceable article. The only alternative available was the basalt, the peculiarities of which have already been described. In 1862, Captain Tyrrell says the Railway contractors were paying 15 Rs. per cubic yard or 55·5 Rs per 100 cubic feet for masonry. In illustration of the general rise of prices he mentions that gram had risen from 45 seers per Re. in 1857 to 25 in 1862; and that wheat flour was at 12 seers, and had been 8.

In March 1863, Captain Tyrrell gave the following detail of the cost of his masonry:—

	Rs.	A.
200 stones, at 3 Rupees per 100,	6	0
Carriage 5 miles (average), at Rs. 2-2 per mile,	10	10
6 masons, at 8 annas,	3	0
Lime,	3	8
Coolies and sand,	3	14
	<hr/>	
Per 100 cubic feet ..	27	0

It will be noticed that masons then cost 8 annas a day; they now get 12 to 14 annas; carts were 10 annas a day, they now cost 1 Re. and sometimes Rs. 1-4.

In January 1864, Captain Foord brought to special notice the cost of carriage in Berar. For travelling in one direction a cart and pair of bullocks then cost 4 annas a mile, or Rs. 2-8 for a short march of 10 miles, and by daily wages they received 2 Rs. a day. Camels cost 5 Rs. per day. These enormous rates were caused he says by the competition of native speculators trying to get their cotton down to Bombay. In June 1864, Captain Foord with regard to certain rates in a schedule prepared by him, that were objected to by the Chief Engineer, reported that carts were still 2 Rs. a day, but that he hoped to reduce this rate to 50 Rs. per mensem by importing from Secunderabad; that bamboos were 10 Rs. per 100; and remonstrated generally against any reduction of his rates, which were based on what he was actually paying.

In November 1864, Mr. Allan Wilson, Executive Engineer at Aurungabad, reported that he had been obliged to raise all his rates. Coolies were then getting 3 annas, masons 10 annas, carts 12 annas a day. The rates at Aurungabad have never risen quite so much as in Berar itself partly because the works have been small, partly from the distance of the station from the Railway, partly because cotton is less extensively grown in the district.

Mr. Wilson also stated that laborers, skilled and unskilled, were emigrating to Berar, and even to Bombay to obtain the higher rates there prevailing.

It will thus be seen that the high rates in Berar date from the increased traffic in cotton which arose in 1862; they reached a maximum about 1864-65, and have since somewhat decreased.

Tables are attached showing the prices of the chief materials, labor, and classes of work:—

- (1.)—As estimated by Captain Foord in his Schedule of 1866-67.
- (2.)—As estimated by the Executive Engineers, East and West Berar, in revised Schedules prepared in 1870.
- (3.)—From recent estimates and completion reports.

Another table shows the average working rates for certain items for each of the six years ending with 1870-71.

These however are deduced from works in progress and whenever the

ments are not very accurately kept, the working rate during construction does not show the real cost; but although some discrepancies appear in the table from this cause, it fairly represents the average rates on the whole.

From the facts that an ordinary unskilled laborer earns about 4 annas a day, and that artisans earn from 12 annas to 1 Re., while mistries or women usually receive about Rs. 1-4, the high prices of materials and of completed work follow as a natural consequence.

It will be seen that there are some discrepancies in the rates of the East and West Berar Division as entered in the Schedules of 1870, arising from under-estimate in the latter, and from the abnormally high rates attained in the former, under a previous Executive Engineer. The rates in the two divisions have since tended towards uniformity.

The cost of earthwork, Rs. 8 for dressed foundations, and about Rs. 6 for ordinary banks and cuttings in road work, is high compared with the rate of cooly labor, 4 annas a day. But it must be explained that the supply of such coolies is very limited, and that for all earthwork on a large scale, quarrying, collection of road metal, &c., recourse must be had to the wandering tribes of Wuddurs (called in the North-West Oods, or Oords.) These men have long been accustomed to high wages on the Railways, and like our English navvies they live well and expensively. They will not work except at rates which bring them large wages.

It is scarcely within the province of this report to discuss the general reasons why labor is dearer and prices higher in Berar than in other districts of India. The laws governing the rate of wages form a disputed chapter in political economy; but there are certain circumstances existing in Berar which may well be noticed here, as affecting the possibility of reducing the cost of labor by importation.

It has lately been urged with considerable force* that the wages of unskilled labor are determined in a country where access to land is not artificially restricted, by the amount which a peasant can earn by farming on his own account. Now Berar is a district where "free trade in land" eminently prevails. † There are the greatest facilities for taking up or relinquishing land for cultivation, and as only one-fourth, it would seem, of the cultivable area is under cultivation, ‡ it is not as yet necessary to resort to the poorer soils. Further the settlement is "ryot-waree" and

* Westminster Review, No. LXXI., January 1872, page 188, et seq.

† Administration report, 1870-71, page 15.

‡ *Ibid.*, page 2.

the assessment light ; the balance of the produce, after paying the Government share, which under a Zemindaree tenure is divided between the proprietor and the actual cultivator, in Berar goes wholly to the latter. Lastly, the staple of the district, cotton, is a very profitable crop. The result of all this is that agriculture is both a profitable and an accessible occupation, and not until cultivation has extended to a much larger area so that the new comers are restricted to the poorer soils, and the profits limited accordingly, can it be expected that immigration will materially lower the wages of unskilled labor.

The rate of wages of the artizans is subject to more complex conditions ; it is affected by competition, custom, the price of food, and by the standard of living customary with these classes. The price of food in Berar is high, because so much of the land is taken up with cotton that cereals have to be imported. Further the competition for skilled labor during the construction of the Railway established a high rate of wages, and natives are especially unwilling to submit to a reduction of nominal rates even when from an increase in the purchasing power of money, such reduction would leave them really as well off as before. The attachment of the natives to "dustoor" has thus prevented the reduction of wages which might have been expected to follow the general fall of prices after the cotton crisis.

In addition to this, the standard of living or of comfort to which they are accustomed has gradually risen, and they would now be unwilling to accept the wages of 12 or 15 years ago, even if the purchasing power of money were the same.

Thus the only prospect of reducing the cost of skilled labor would be the accession of a state of things in which the supply much exceeded the demand, which in time would induce the artizans to submit to lower wages to procure employment at all. It is notorious, however, that the tendency is quite in the opposite direction.

It seems doubtful whether the increase of the artizan class has kept pace with the great extension of Public Works in the last few years, and in every direction there is difficulty in collecting masons, carpenters and smiths.

Indeed it seems a matter for consideration whether a systematic effort should not be made, either by technical schools or by some plan of Government apprenticeships, to train up an increased supply of skilled workmen.

It will be seen from the above report that there is little prospect of a

reduction in the current rates of work in Berar, depending as they do on the wages of skilled and unskilled labor, both of which are practically beyond our control. The direction in which our efforts for economy seem most to promise success is the substitution of special materials and modes of construction for those hitherto in use. Could any of the various forms of building in béton, pisé work, or concrete be successfully introduced into Berar, a material saving might be effected in the most expensive portions of our constructions.

The experiments about to be carried out on the limes and cements of Berar will help towards this end.

The expense of carriage forbids the use of Portland cement from England, but it may be hoped that ere long that invaluable material will be made available to the Indian Engineer by the establishment of local manufactories. With Portland cement the success of concrete building would be assured, but so long as we are dependent on local limes of uncertain and varying composition, the employment of such a material in large buildings must always be attended with more or less risk.

Statement of mean working rates of some of the more important items of works that have prevailed in the Berars, during the six years ending 1870-71.

	WEST BERAR DIVISION.												EAST BERAR DIVISION.																	
	1865-66.				1866-67.				1867-68.				1868-69.				1869-70.				1870-71.									
	RS.	A.	P.	RS.	A.	P.	RS.	A.	P.	RS.	A.	P.	RS.	A.	P.	RS.	A.	P.	RS.	A.	P.									
Stone in lime, per 100 cubic feet, ..	32	0	0	35	0	0	32	0	0	42	13	1	28	0	0	29	0	0	30	0	0	31	4	0	38	0	0	36	0	0
Stone in clay, per 100 cubic feet, ..	30	0	0	18	0	0	18	0	0	19	9	0	37	0	0	38	12	8	40	2	0	37	8	0	38	0	0	38	0	0
Coursed rubble, per 100 cubic feet, ..	35	4	0	42	0	0	44	0	0	44	8	3	50	0	0	27	10	0	31	0	0	32	14	0	34	0	0	34	0	0
Brick in lime, per 100 cubic feet, ..	20	0	0	22	13	0	24	0	0	25	1	9	50	0	0	48	0	0	43	13	0	43	0	0	43	0	0	43	0	0
Arch work brick in lime per 100 c. ft., ..	44	0	0	31	8	2	48	0	0	34	8	7	3	12	0	3	0	0	3	0	0	3	6	0	4	9	0	0	0	0
Lime pointing, per 100 square feet, ..	3	0	0	4	0	0	4	0	0	3	15	2	4	0	0	4	6	0	4	0	0	3	9	0	4	0	0	0	0	0
Lime plastering, per 100 square feet, ..	4	0	0	4	0	0	4	0	0	6	10	3	0	6	0	0	4	0	0	5	0	0	3	7	0	4	0	0	0	0
White & blue washing, per 100 sq. ft. ..	0	4	0	4	0	0	4	0	0	0	8	9	18	0	0	18	0	0	19	0	0	18	0	0	17	0	0	17	0	0
Brick in clay, per 100 cubic feet, ..	18	0	0	20	0	0	20	0	0	19	11	8	20	7	7	24	5	0	20	7	7	24	5	0	20	7	7	24	5	0
Terrace flooring, per 100 square feet, ..	12	0	0	12	0	0	10	0	0	14	4	0	14	4	0	14	4	0	14	4	0	14	4	0	14	4	0	14	4	0
Chunam flooring, per 100 cubic feet, ..	12	0	0	12	0	0	12	0	0	14	4	0	14	4	0	14	4	0	14	4	0	14	4	0	14	4	0	14	4	0
Terrace roofing, per 100 square feet, ..	30	0	0	30	0	0	35	0	0	36	4	9	30	0	0	24	10	6	30	6	0	27	6	4	32	0	0	32	0	0
Tiled roofing, per 100 square feet, ..	25	13	11	25	0	0	20	0	0	25	0	0	25	0	0	25	0	0	25	0	0	23	4	0	23	4	0	20	8	0
Teak wood, per cubic foot, ..	6	12	0	4	8	0	4	8	0	5	5	0	7	5	5	0	5	0	5	0	0	5	0	6	0	6	0	6	0	
Batten doors, per square foot, ..	1	0	0	1	0	0	1	2	0	1	2	0	1	2	0	1	2	0	1	2	0	1	2	0	1	2	0	1	2	0
Doors, venetian, per square foot, ..	2	0	0	2	0	0	2	0	0	1	10	0	1	10	0	1	10	0	1	10	0	1	10	0	1	10	0	1	10	0
Doors, pannelled, per square foot, ..	1	8	0	1	8	0	1	8	0	1	13	0	1	13	0	1	13	0	1	13	0	1	13	0	1	13	0	1	13	0
Doors, glaze, per square foot, ..	1	8	0	1	8	0	2	4	0	2	4	0	2	4	0	2	4	0	2	4	0	2	4	0	2	4	0	2	4	0
Wrought-iron, per cwt., ..	15	0	0	15	0	0	20	0	0	20	0	0	22	15	0	22	15	0	22	15	0	22	15	0	22	15	0	22	15	0
Corrugated iron, per cwt., ..	15	0	0	15	0	0	20	0	0	20	0	0	22	15	0	22	15	0	22	15	0	22	15	0	22	15	0	22	15	0
Earthwork, per 100 cubic feet, ..	0	10	2	0	13	3	0	12	9	0	12	9	0	12	9	0	12	9	0	12	9	0	12	9	0	12	9	0	12	9
Metalling with moorum, per 100 c. ft. ..	2	12	0	3	0	0	2	14	0	3	0	0	3	5	4	0	15	9	3	10	0	3	13	0	4	0	3	0	0	

• Including Portland cement.

RATES OF WORK IN BERAR.

107

	1866-67.	East Berar Schedule, 1870.	West Berar Schedule, 1870.	East Berar Estimates, 1871-72.	West Berar Estimates, 1871-72.
WORK COMPLETE.					
	Rupees.	Rupees.	Rupees.	Rupees.	Rupees.
Excavating foundations not exceeding 5' deep, per 1,000,	8	8	6	8	8
Brick in lime mortar, plain walling, not exceeding 20' from the ground, per 100, ..	25	29	30	26	28
Stone concrete, including filling, per 100, ..	15	15	15	15	15
Madras terraced roofing (exclusive of joists), per 100, ..	30	30	35	25	25
Rubble masonry in lime in superstructure, per 100, ..	36	35	32	32 to 36	32
Coursed rubble, per 100, ..	44	38	40
" in arches including centering,	48 to 60	48 to 60	48 to 60	66	..
Block in course, ..	72	80	75
Ashlar, per square foot, ..	1-0 to 1-4	1-4 to 1-8	1-0 to 1-4	..	1 8
Moulmein teak, fixed and framed, ..	4-2 0	7	5	5-8-0	6
1½ framed panelled teak doors square feet ..	1-4-0	2	2-4-0	1-10-0	1-8-0
LABORERS.					
Laborers for earthwork, ..	0-4-0 to 0-6-0	0-3-0 to 0-5-0	0 4-0 to 0-5-0
Boys, ..	0-2-0	0-2-0	0-2-0
Women, ..	0-2-6 to 0-3-6	0-2-0 to 0-2-6	0-2-0
Cart and pair of bullocks, ..	1-8-0	1-0-0	1-4-0
Fair of bullocks and driver, ..	1 0-0	0 12-0	1-0-0
Bricklayer, mistry, ..	1-4-0	1-4-0	1-4-0
" ordinary, ..	0-12-0 to 1-0-0	0-12-0 to 0-14-0	0-12-0 to 1-0-0
" inferior, ..	0-8-0	0 8-0	0-8-0
Stone-cutters, ..	0-14 0	0-14 0	0-14-0
Stone-masons, ..	0-12-0	0-12-0	0 12-0
Black-smiths, ..	1-0 0 to 1-4-0	1-0 0 to 1-4-0	1-0-0 to 1-4-0
Hammer-men, ..	0-8-0	0-8-0	0-8-0
Carpenters, mistry, ..	1-4-0	1 4-0	1-4-0
" ordinary, ..	0-14-0 to 1-0-0	0-12-0 to 1-0-0	0-14-0 to 1-0-0
" inferior, ..	0-8 0 to 0-10-0	0-8-0 to 0-10-0	0-8-0 to 0-10-0
MATERIALS.					
Delivering hard moorum at roadside road, not exceeding ½ a mile, per 1,000 c. f.,	8	15	15
Bricks 9" x 4½" x 2½" delivered at the works, per 1,000,	9	9	9
Pan tiles delivered at the works, per 1,000, ..	6	6	6
Flat tiles delivered at the works, per 1,000, ..	4	4	4
Lime burnt at works, per 1,000 cubic feet, ..	28	32	32-8-0	..	25
Charcoal burnt at works per maund, ..	2-8 0	..	2-8-0
Rubble stone delivered at works, per 1,000 cubic feet,	16	10	10	..	8
Arch stones, per 100 stones, ..	30	35	30
Moulmein teak beams, die square, per cubic foot, ..	3	6-8*	3-8-1	..	5-8-0*

* Including labor.

No. LXX.

EXPERIMENTS ON SELENITIC MORTAR.

BY CAPT. E. V. TWEMLOW, R.E., *Exec. Engineer, Belgaum.*

THE annexed tables show the breaking or tensile strain on an area of four square inches of selenitic common lime gauged neat and with different proportions of sand.

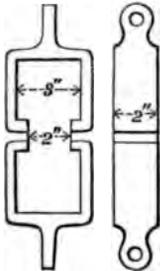

The mould in which the test bricks were made, was shaped as per sketch, so as to give a sectional area of two inches square at the point of fracture.

The weights were applied by means of a wooden lever constructed as per sketch.

The scale platform, containing the weights, was made to move along the longer arm, by suspending it to a small carriage or roller.

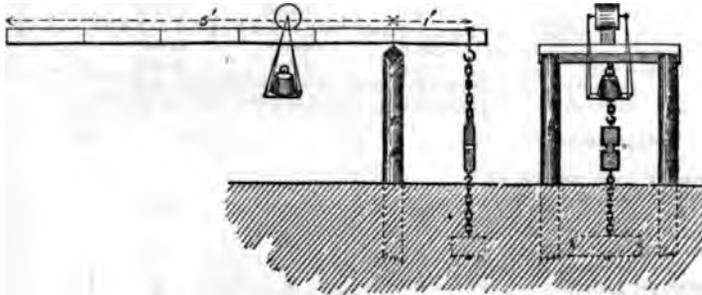

The lime, styled "selenitic," was manufactured by slaking the common freshly burnt lime with water containing five per cent. of strong sulphuric acid (oil of vitriol).

The lime used throughout the experiments is that in ordinary use at Belgaum. It is burnt from a large sized kunkur, containing a considerable proportion of clay in its composition. The lime is burnt with charcoal

in ordinary native kilns. The sand is coarse black river sand. The mortar used on the Belgaum barracks is a mixture of 1 part of this unslaked lime, to $1\frac{1}{2}$ parts of sand, and numerous experiments have shown its mean tensile strength on an area of four square inches, to be as follows :—

Age.				Breaking at
10 days,	90 lbs.
20 "	120 "
30 "	150 "
60 "	170 "

The addition of the sulphuric acid has the effect of doubling the strength of the lime; also it enables the lime to bear an admixture of three times the quantity of sand to reduce it to the strength of ordinary mortar made with plain water. To slake one cubic foot of fresh lime, requires 20 pints of the acid solution, so that in a 5 per cent. solution, one pint of pure acid is necessary. If selenitic mortar composed of 1 of lime to 4 of sand is used, about $7\frac{1}{2}$ cubic feet of lime would be required for 100 cubic feet of rubble masonry: or, $7\frac{1}{2}$ pints (equal to 17 lbs.) of sulphuric acid, which at the Belgaum price of 8 as. per lb. would add Rs. 8-8 to the cost of masonry per 100 feet. Against this may be placed the saving in the quantity of lime, or about 8 cubic feet, if mortar of 1 lime to 2 of sand be in ordinary use. The relative cost would be in favor of the selenitic mortar, only in those places where lime is very expensive, or where the materials for the manufacture of sulphuric acid exist.

The experiments are not sufficiently numerous to establish any definite conclusion; but as far as they go, they seem to show that the strength of selenitic lime, made from kunkur, is about equal to Roman cement, and $\frac{2}{3}$ ths that of Portland cement. The breaking weights, at 30 days being as follows :—

				Per Bri- quette	Per sq. Inch.	Remarks.
Portland cement,	679	310	} Taken from Tables 17 and 24 of Grant on the Strength of Cement.
Roman cement,	243	108	
Selenitic kunkur limes,	480	120	

A solution containing 3 per cent. of acid was tried, but it gave results only $\frac{2}{3}$ th the strength afforded by the 5 per cent.

Bricks of selenitic lime, exposed to air instead of being immersed in water, showed a slight increase of strength.

TABLE of the results of experiments with common and Selenitic lime, gauged neat and with different proportions of sand, showing the breaking weight on a sectional area of 4 square inches.

TEN DAYS' TESTS.

	Ordinary kunker lime, gauged neat.	Gauged neat.	SELENITIC LIME.									
			Proportion of Lime to Sand.									
			1 to 1	1 to 1½	1 to 2	1 to 3	1 to 4	1 to 5	1 to 6	1 to 7	1 to 8	
Immersed in water 12 hours after making, ..	151	314	..	175	159	101	81	90	54	
	145	292	..	179	188	97	114	81	89	
	138	347	..	209	131	135	105	69	59	
	134	260										
	121	312										
	154	140										
	145	127										
	148	300										
	127	152										
114	192											
Mean results, ..	138	244	..	188	159	111	100	80	67	

TWENTY DAYS' TESTS.

Immersed in water 12 hours after making, ..	240	416	195	182	172	82	102	102	82	82	122
	180	398	182	202	162	102	122	82	75	75	82
	240	304	225	182	155	92	128	82	122	72	122
	186	535	228	148	162	108	98	102	82	62	92
	180	392	198	208	155	122	98	92	82	52	99
	260	399	208	192	157	155	102	82	82	52	..
	200	269									
	180	478									
	180	469									
	193	403									
	Mean results, ..	204	406	206	186	160	110	108	90	87	66

THIRTY DAYS' TESTS.

Immersed as above, ..	260	332								
	246	422								
	293	497								
	266	449								
	283	535								
	253	535								
	240	535								
	300	392								
	270	582								
	290	525								
Mean results, ..	270	480								

E. V. T.

Correspondence.

To the Editor Professional Papers on Indian Engineering.

DEAR SIR,—Perhaps the following note may be thought to bear on Major Corbett's theory, that irrigation would become unnecessary in Upper India if deep cultivation could be introduced.

In the Bann valley, the low lands not only get an abundance of water from the Koorum river, but with the water a large quantity of very fertile deposit. These lands are carefully and deeply cultivated, principally by the spade.

The higher lands which get either no irrigation at all, or an uncertain supply from mountain torrents, are merely scratched in the usual Indian fashion. Does not this seem to point to the conclusion that deep cultivation is only practicable where irrigation renders the cultivator certain of a return for his outlay? and that so far from deep cultivation being a substitute for irrigation, it is only on irrigated lands that deep cultivation can be profitably employed.

EDWARDESABAD, }
13th January, 1873. }

Yours truly,

J. B. LINSELL, LIEUT., R.E.,
Assistant Engineer.







DELHI CLOCK TOWER

 No. LXXI.

 DELHI CLOCK TOWER.

 [*Vide* Photograph and Plate X.]

Article communicated by E. J. MARTIN, Esq., C.E. *Photograph executed by* LIEUT. CLAYTON BEAUCHAMP, R.E.

THE Municipal Commissioners of Delhi have effected many useful improvements in that city since the mutinies: the streets are now, perhaps, the cleanest and best drained, and repaired, of any native city in the Upper Provinces.

A fine Town Hall, with a Ball-room, Museum, Lecture-room, a magnificent Durbar Hall, measuring 80 feet long and 40 feet wide, and an extensive Serai for the accommodation of native travellers, may be specially mentioned amongst the many useful and ornamental works that have been constructed by the Municipality. Trees have been extensively planted along the road sides; handsome cast-iron pillars from England have superseded the old wooden posts that formerly supported the street lamps; large tanks have been constructed; the old King's gardens have been tastefully laid out, and vastly improved; new gardens have been formed; and almost everything that taste or intelligence could suggest for the conservation and embellishment of the city, has been carried out.

The latest improvement is the new Clock Tower, which stands in the centre of the Chandnee Chowk, opposite the Town Hall.

This building is erected in an appropriate and commanding site at the crossing of four streets, and stands 110 feet high, exclusive of the ornamental gilt vane and finial. The materials used in its construction are brick, red and yellow sandstone, and white marble. The capitals sur-

mounting the main corner pillars are 4 feet 2 inches wide at top, and 4 feet 6 inches deep, they are carved out of solid blocks of white sandstone, and each of them weighs about 2 tons.

The dials of the clock are sufficiently elevated to be visible from the East Indian Railway station, and from other prominent points in the city.

The clock is constructed to work five bells, placed in the open canopy above it, these give out a different peal for each quarter, the largest bell striking the hours.

The building has been completed in 18 months, at a cost, including clock and bells, of Rs. 28,000, the whole of which amount was provided from Municipal Funds.

The tower was designed and built by Mr. E. J. Martin, Exec. Engineer, Rajpootana State Railway, and the Clock and Bells were supplied by Benson and Co., Ludgate Hill, London.

SPECIFICATION.

Enclosing site.—A strong paling, about 4 feet in height, and composed of rough bullies, to be erected, to enclose the ground on which the Clock Tower is to stand. To prevent accidents, watchmen will be employed to keep people clear of the works, and at night, lanterns will be suspended at the corner posts of the enclosure.

Excavation for foundations.—The ground to be excavated until a thoroughly firm and secure foundation is obtained, and to be carefully levelled to receive the concrete.

Concrete in foundations.—To be composed of 1 part mortar, to 2 parts broken stone or vitrified brick. The mortar to consist of 1 measure of charcoal-burnt kunkur lime, and 1 measure of soorkee or budgree. The stone or brick to be broken up into $1\frac{1}{2}$ inch cubes, the whole to be carefully mixed, and thrown into the foundations from a* height of at least 10 feet, and to be thoroughly rammed in 6 inch courses.

Masonry in foundations.—To be of the best coursed rubble in lime mortar masonry, well and securely bonded, with a sufficient number of thorough bond stones introduced at proper intervals, in every course. The mortar throughout the building being the same as that specified for concrete.

* This mode of 'throwing' concrete is opposed to the best recent practice in concrete laying.—[ED].

CLOCK TOWER-DEHLI.

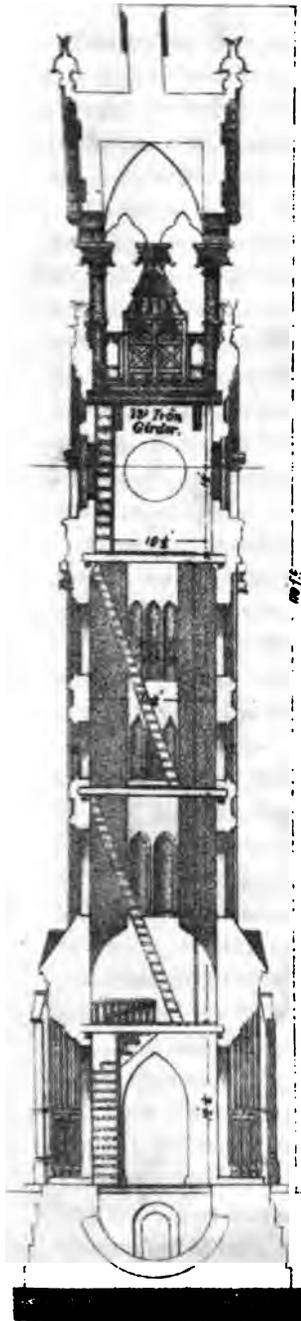

Scale. 18 feet to an inch

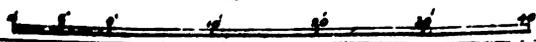



Masonry in superstructure.—The body of the work will be of brick in lime mortar masonry, the cornices, pinnacles, caps, bases and shafts of columns, jambs, mullions, arches, and transoms of windows, pinnacles, finials, crockets, barges, hood moulding, water tables to buttresses, strings, &c., &c., to be of cut sandstone, in accordance with the drawings.

The brickwork to be of the very best description; the bricks are, where necessary, to be rubbed on the face, and to be laid with close joints in English bond, in finely tempered mortar. The bricks to be well and squarely moulded, free from inequalities, and properly burnt, no jhama or peela bricks to be used. The different kinds of cut stone-work, including plain, moulded, and carved ashlar, to be neatly and correctly worked to the shapes and dimensions given on the drawings. The stones to be of a uniform color, and free from unsightly stains. All projecting edges to be throated underneath, and copper joggles or dowels to be introduced where needed.

Stone flooring.—The lower floor to be flagged with 2 inch thick flag stones, laid with the finest possible joint, on $4\frac{1}{2}$ inches terracing over 18 inches of stone spalls.

Carpentry.—All the timber used in the building to be of the best sal wood (*Shorea robusta*) obtainable, free from all imperfections, to be correctly worked to the dimensions given on the plans.

Clock and Bells.—The bells to be fixed above the dials, with a clear open space round them, in order to let out the sound. The hammers to be very strongly screwed to the beams of the bell frame, the largest hammer to the largest bell, care to be taken that they do not touch the bells when at rest, but yet give a good firm blow when in action. The bell frame to be constructed as shown on plans, with a sufficient space between it, and the walls to afford room for the descent of the weights.

Immediately below the bells, and on a level with the centre of the dials, will be fixed the bevel wheel work.

Behind each dial screwed to a shelf, will be placed one of the motion works, communicating with the bevel wheel work by a rod. Below this will come the movement of the clock, raised above the floor on a stool about 3 feet high, and connected by a rod with the bevel wheels above. The single hammer tail at one end of the clock should then be connected with the largest hammer, which strikes on the largest bell (No. 5). The hammer tail at back of clock, (the back of clock is where the pendulum

swings,) will be connected with No. 4 bell; the next tail to it with No. 3, and so on.

The hour striking part and the going part, each takes 48 turns to go for 8 days, the chime part, 75 turns. Double lines should be used as shown on diagram. The striking part takes one 8-inch weight, and 4 shifters, the going part a small weight, and 2 small shifters, the chime part one 8-inch weight, and 9 shifters, as 75 feet cannot conveniently be obtained for the fall of the quarter weights, this part of the clock will have to be wound twice a week. A distance of 50 feet down which the going and striking weights can descend, will be sufficient to enable those two parts to perform for 8 days.

ABSTRACT.

		RS.
22,016	Excavation of foundation, including baling water, &c., at Rs. 2-4-0 per 100 cubic feet,	495
13,758	Pucka masonry and concrete in foundation, at Rs. 11-8-0 per 100 cubic feet,	1,582
13,453	Ditto superstructure, at Rs. 24 per 100 cubic feet,	3,229
17,027	Sal wood-work, at Rs. 3-8-0 per foot,	596
2	Iron girders, at Rs. 30 each,	60
8,537	Stone work moulded, at Rs. 4 per foot,	14,268
4½	Maunds copper work, at Rs. 100 per maund,	450
20	Caps and pinnacles carving, at Rs. 20 each,	400
	Total,	21,080
	Contingencies at Rs. 5 per cent.,	1,054
	Grand Total Rupees,	22,134

E. J. M.

No. LXXII.

REPORT ON EXPERIMENTS MADE ON KUNKUR MOR-
TARS AND CONCRETE.

[*Vide* Plate XI.]

By A. NIELLY, Esq., *Assist. Engineer in Charge of Experiments.*

Gurdáspúr, 26th February, 1873.

This report will be divided into two parts. The first treats of kunkur cement mortars; describes simple analytical and experimental means of testing the cementing properties of kunkur; proves that most of the burnt kunkurs belong to the class of cements; and, lastly, gives an outline of the manner in which it is proposed to conduct some experiments on artificial cement.

In the second part will be found the fundamental principles on which concrete making is based, the results of experiments on specimens of concrete tested at Madhopur, and some suggestions derived from those experiments; also comparisons between our results and those obtained elsewhere: this is followed by a brief description of Coignet's system of stone making, and by a recapitulation.

PART I.—The kunkur cement laid experimentally last year in the great weir at Madhopur having been successful, orders were given to cement the upper layer of the repaired portion of the weir with kunkur cement mortar. The cement made at Runiah with the unwashed nodule of Bathala kunkur, and at Pathankote with vesicular tufa, was supplied fresh and unslaked to Lient. S. Jacob, R.E. This officer having satisfied himself that when water was mixed with the material supplied to him, the

setting action commenced almost immediately, came to the conclusion that he had to deal with a natural cement, and treated it as such; that is, ground it as fine as practicable, and laid it in the work immediately after it had been wetted, taking great care that no cement should be left wet in the evening for the following day's work. Each day's masonry was covered with a layer of wet sand, which was kept moist as long as necessary. The season of the floods has now passed, and although there has been no such heavy flood this year as the year before, still a very large body of water has been continually passing over the weir, and the only damage done to the repaired portion, is one small hole, from which about eight boulders have been displaced.

The grinding of the cement for the above-mentioned works was a very great improvement on the manual pounding, although the degree of fineness obtained was only sufficient to allow the ground cement to pass through a sieve of 40 meshes to the inch (it should pass through a sieve of from 60 to 80 meshes). Lieut. Jacob took advantage of the water power at his disposal to erect native mills close to the works, and after breaking the burnt kunkur in smaller fragments, ground it in the same way that corn is ground. It was found that the rough state of the mills made them troublesome, so improvements are now being considered with a view to using cheap water power on the works for the remodelling, and on the manufacture of artificial cements.

At the last closing of the canal in January 1872, I was ordered to carry out the repairs of the rapids, and was allowed to use kunkur cement for the work. The quantity of cement at hand being limited, a third in bulk of stone lime was mixed with the cement, and the concrete was composed as follows:—2 kunkur cement, 1 stone lime, 3 pebbles from bed of canal.

It was explained in a previous report that the mixture of 1 stone lime to 2 kunkur cement, gave a better proportion of caustic lime to clay: another reason for this mixture is that the great setting activity of the cement is beneficially retarded by the mixture of lime, when that mixture does not exceed the proportion of 1 to 1 (*see* General Gillmore's Practical Treatise on Limes, &c., paras. 381 and 550). Some Engineers in this province have before found experimentally that it is advisable to mix stone lime with kunkur cement; but the variety of burnt kunkur with which it is good to mix stone lime, not having been pointed out, and the cause of

the beneficial action not having been explained as above, other Engineers were led to doubt whether any advantage was gained by the mixture. (See Mr. J. E. Tanner's valuable report, dated 29th Sept., 1869, and Mr. E. C. Palmer's able report on certain experiments, &c.) In truth, the composition of kunkurs varies so much that it cannot be said in a general way that stone lime ought to be mixed with what is known under the popular name of kunkur lime: for instance, if the mixture with stone lime is good for Bathala cement, it would be decidedly bad for Vahn or Lucknow No. 1 kunkurs, which contain already an excess of lime.

It should be here mentioned, that much confusion arises from the fact that burnt kunkurs are commonly classed under one head, no proper nomenclature being adapted for the different varieties. In consequence of this, rules for hydraulic limes are often wrongly applied to cements, and bad mortar made out of really good materials. However chemistry alone can make the required discrimination, so simple chemical means of ascertaining the cementing values of kunkurs will be given further on in this report.

To return, however, to the subject of repairs to the Rapids, the setting activity of the Bathala cement, even when mixed with stone lime, was taken advantage of to repair deep indentations in the cutwater of a few piers damaged by logs; it was also relied on to build one of the missing piers of No. 7 Rapid, and to fill the interstices between the boulders in a chosen space in the centre of Rapid No. 10, 24 hours before the re-opening of the canal.

Coarse sand having been found in one of the rajbhas, a sand mortar—composed of 2 volumes kunkur cement, 1 volume of lime, 3 volumes coarse sand—was used to carry out large repairs at the bottom of the cistern of a vertical fall, and as the samples of this mortar kept in water have taken a high degree of induration, it is expected that such mortar will be successful, and that it will be possible to effect a great saving both in labor and material, by using this sand on the projected works. As the mortar used on the Rapids, however, is still undergoing trial, and as until the canal is closed in January, 1873, it will not be possible to closely examine the repaired portions and draw any conclusions, no more will be said on this subject at present.

We will now turn to a very important point, and one on which very conflicting ideas exist: viz., the more or less wet state of mortar when

ready for use. It is agreed that theoretically the less water a mortar contains within certain limits the better it is, and there is no doubt that an apparently incoherent mortar used for concrete laid in a place where it can be easily rammed will give the best results; because the cohesion of the elements of the concrete is completed by the blows of the rammer. If there is a large excess of water in the mortar, the action of the rammer is impeded by the quicksand motion which takes place, and the result is a very porous and comparatively feeble concrete. If there is only a small excess of water, a film of it simply oozes out of the surface rammed and the result is a concrete slightly more porous than if the exactly correct quantity of water had been mixed. As, however, few have acquired the practice of judging that quantity of water, it is recommended to use a small excess rather than run the risk of leaving the concrete deficient in dampness. But if an apparently incoherent mortar is very good under the influence of the rammer, it will not answer under the influence of the trowel, even when handled by an European mason. The incoherent particles of the mortar which incessant blows only will join, remain divided, and if such mortar even when composed of the best cement is used by the mason, it will be found on the following day to have fallen to powder. In the absence of ramming, water is therefore the agent which brings the particles together, so the European mason is provided with a solid paste of which he can take a good quantity on his trowel, and throw it so as to fill all the interstices of the material he is building with; whereas the Indian mason, who has to work in an atmosphere which so quickly absorbs moisture, who besides likes to exert himself as little as he can, uses a much less solid paste, which runs almost of itself in the interstices.

This produces work more porous than good European mortar, but fairly strong if the ingredients used are of good quality and properly mixed. It is unwise, therefore, to force native masons to use a stiff mortar, as any change of that kind is sure to produce masonry left incoherent, an evil much greater than porous mortar. When a mortar composed of fat lime and puzzuolana of some sort is used, porosity has its advantages, as it facilitates the ingress of carbonic acid, and the consequent quicker solidification of the mortar. When good cement, natural or artificial, is used, the small excess of water can do little harm, for we find that some eminent Engineers and chemists of different countries have solidified blocks of

gravel and pebbles by forcing liquid cement through them; (General Gillmore, paras. 494, 509, 515;) and again we see that nature produces many of its masses of conglomerates and sandstones by the infiltration of calcareous matter through incoherent masses of boulders and sands.

The greatest cause of anxiety for an Engineer in charge of masonry works is not therefore the small excess of water that his native masons use, but rather that the setting energy of his kunkur cement should not be broken, and the strength of his cementing material be not reduced to that of feebly hydraulic lime, by the employment of mortar in which the setting action has been going on for some time. This point is so important, that every effort will be made in this paper to induce those who have to deal with kunkur, to satisfy themselves that the material called "kunkur lime" comprises a variety of materials, most of which, if Vicat's typical classification is adhered to, belong to the classes of cements, and cannot therefore be treated like hydraulic limes, (*see* page 124 of this report.)

There are however reasons for suspecting that a kind of kunkur (among the richest in carbonate of lime), belongs to that dangerous class of intermediate or limit hydraulic limes. This class, which does not appear to occur in England, is well known to the American and French authorities on limes and cements, who agree in advising that they should not be used except with great caution. These intermediate limes which set with very great rapidity in air and water, suddenly lose their cohesion, crack, expand and soften, a few hours after having been used like cements.

Vicat and Gillmore say that they can be reduced in setting activity by remixings with water, and that they can be brought to the standard of ordinary hydraulic limes, and used as such. It appears probable that the use of intermediate kunkur limes in India, gave rise to the popular saying among contractors and overseers, that water is the life and soul of kunkur lime, and gave birth to the public works rule* that kunkur lime requires to be soaked for 24 hours and thoroughly worked with water. This rule is applied in practice, not only to the kunkurs which produce hydraulic or intermediate limes, but to those which produce cements; the result is that

* The rule alluded to is not in the Code, but is one of those traditional rules which ought to become obsolete.

the setting qualities of the cements are destroyed, and that they are reduced to the standard of feebly hydraulic limes.

Now let us proceed to the means within reach of every Engineer of discovering for himself the class of limes and cements to which the material at hand belongs. The two principal components of our cementing materials, "carbonate of lime and clay" are the only ones which it is absolutely necessary to know to classify our materials. The knowledge of the other components is useful in this way that when at some future time, a number of analyses of cementing materials and the results they give when used in mortar and in concretes shall have been recorded: the chemist and the Engineer will be able to draw sound inferences as to the action of each component on the setting qualities, and on the ultimate power of induration. It is advisable, therefore, that complete analysis and experiments should be recorded by special men; but as long as the inferences cannot be drawn on a sufficiently wide and sound basis, the two principal ingredients, "carbonate of lime and clay," will be the only ones of immediate interest to the Engineer. The question is, therefore, how their determination can be obtained by simple means.

The process by hydrochloric acid having been detailed in several popular publications, it may be supposed to be familiar; it will not be, therefore, described again, and the examination of the results obtained by that process shall be proceeded with. The action of hydrochloric acid is simply to isolate the silica and insoluble silicates, whose weight is obtained and recorded, but it would expose us to great errors if in all cases we took the difference between the above weight, and the total weight of the sample as the weight of the "carbonate of lime." The reason of this is, that the solution thrown away contains not only the lime united with the hydrochloric acid under the form of chloride of calcium, but also the alumina, oxide or peroxide of iron, magnesia, potash, soda, &c., the sum of which last elements is often more than two-fifths of the total weight of the sample. The error committed is a minimum when the material analysed is nearly pure carbonate of lime, a kind of lime rare in the Punjab: the error is a maximum when the material is an impure carbonate like our kunkurs.

The process by hydrochloric acid leading to great errors, the detail of another process which can be found in Mohr, Vol. 1, page 69, will be proceeded with.

The principle on which the following process is founded is that one cubic centimetre of nitric acid decomposes $\cdot 05$ gramme carbonate of lime. The chemicals required are nitric acid and caustic potash or soda, so combined in strength, that one cubic centimetre of caustic potash will exactly neutralise one cubic centimetre of nitric acid: also litmus paper or tincture. The instruments necessary are two of Mohr's graduated tubes with glass cocks and stand. When the raw material, which is to be experimented upon, has been finely powdered, so that no grittiness remains in it, take one gramme for instance, place it in a cup under the graduated tube containing nitric acid, and let the acid flow gently on the powder until litmus paper dipped in the solution turns red, or until all effervescence ceases. Suppose when this happens that 15.5 c.c. of acid have been expended; since the reddening of the litmus does not show exactly that all the carbonate of lime has been decomposed, add some more nitric acid, say $2\frac{1}{2}$ c.c., so that 18 c.c. of nitric acid will have been employed. Having used more than was required we must find the excess; this is done by carefully adding caustic potash to the solution until it is neutralised, which is shown by its action on litmus. Suppose 2 c.c. of caustic potash have been employed to obtain that result, then $18 - 2 = 16$ c.c. is the real volume of nitric acid which has entirely decomposed the carbonate of lime; then as 1 c.c. nitric acid shows $\cdot 05$ carbonate of lime, so 16 c.c. nitric acid show $\cdot 8$ carbonate of lime. Our sample contains therefore 80 per cent. carbonate of lime, and 20 per cent. clay, and is likely to be an eminently hydraulic lime.

If the sample was suspected to contain sand, 50 grains of it should be treated by the hydrochloric acid process, and when the silica and insoluble silicates would have been obtained, the sand should be separated from the silica by careful washings, the weight of it ascertained, and deducted from the amount of clay previously obtained by the nitric acid process.

The above simple ways of finding the two principal components of our kunkurs, "carbonate of lime and clay," and also sand, which is rarely present, having been given, it might be thought that all that is needed in order to classify them had been done. But this is not the case, because analyses of raw limestones rarely give perfectly accurate ideas of the nature of the cementing material it will produce after burning, the degree of hydraulicity often depending on the degree of combustion. A few

simple ways of testing the burnt material will be, therefore, described. The following test should not be applied to materials burnt by contractors, except for the sake of comparison, as pure cementing material is not to be expected from those who can so safely adulterate their produce. The Engineer should therefore burn departmentally, and, if possible under his own eye, one or two hundred cubic feet of the raw material in the ordinary conical kiln; the fuel may be oopla in the proportion of 2 volumes oopla to 1 volume kunkur, during the hot season, and of 3 volumes oopla to 1 volume kunkur during the coldest part of the winter. The exterior of the kiln should be plastered with mud. When the kiln is unloaded, a set of coolies supplied with baskets should be placed round it, to pick up carefully from the ashes and make separate stacks,

1st, Of the kunkur, which is light and easy to break with the hand;

2nd, Of the kunkur, which is still hard and heavy;

3rd, Of the vitrified kunkur, to which adheres generally some kunkur from which the carbonic acid has been completely expelled. When the kiln is carefully made, the qualities 2 and 3, constitute only from 5 to 10 per cent. of the kunkur placed in the kiln, and they are useful in this way, that they furnish samples of the material at various stages of burning, and enable us to find by experiments at what stage of combustion the burnt material gives the best cements.

When those samples have been selected, tried as to their power of slaking, and tested with an acid to ascertain the presence or absence of carbonic acid, they are subjected to simple experiments, the object of which is to ascertain their hydraulicity or power of setting under water. For these experiments Vicat's needle (adapted to English measures by General Gillmore, who gives of it a good description, and a drawing, and also the results of many experiments) is certainly a useful instrument, but as it is not to be found except in the office of men who make a regular business of the study of limes and cements, we must try to do without it. A very fair knowledge of the setting qualities, and of the ultimate degree of induration of the kunkur at various stages of combustion, may be easily obtained by making a good number of little balls, with every sample, reduced to fine powder, marking these balls, placing them under water of at various intervals of time, carefully examining them and recording every step. An ordinary needle can be used to test the hardening action and the feeling of more or less gentle pressure exerted by the hand, is

sufficient to give an idea of the rapidity with which that action is going on. The balls should be tried and examined in the above way for one or two months, and the results carefully noted. After that time, the Engineer will be able to come to a conclusion as to which sample has given the best result. It should be remarked here that it is not always the sample which has set first, which at the end of one month and sometimes more, proves to be the strongest.

When the Engineer has thus ascertained the principal components of the material at hand, the degree of combustion which best suits the materials, and the setting qualities of each by the above plain analysis and experiments, he will be in possession of all the main points upon which the subsequent arrangements for burning kunkurs and making mortars and cements are to be founded. There are, however, other details which it is useful to work out, such as the complete analysis already mentioned, the resistance to pressure, to transverse strain, the tenacity, &c., but these are rather within the province of special men who ought to be in possession of all the apparatus required for finding such results.

If the "Roorkee Treatise"* and the various reports drawn up before the year 1871, are consulted as regards the knowledge of the kunkurs, and the cementing materials they produce, it is found that kunkur lime is the general appellation under which all the varieties fall. The effects of such generalization have been pointed out in page 117. The true appellation of cements is therefore claimed for most of the burnt kunkurs. The analyses given in the "Roorkee Treatise," Vol. 1, 2nd edition, para. 77, and those given in the last number of the "Roorkee Professional Papers," by Doctor Murray Thomson, F.R.S.E., furnish proofs of their right to be called "cements." If these analyses are condensed in the two principal sub-divisions of "carbonate of lime and clay," as in Table B., and if they are compared to the types given by Vicat in Table A., most of them are found to belong to the classes of cements. The "Roorkee Treatise" states, that Vicat's classification has been adopted; there is however some difference between the percentages given by the Table A., and the percentages given in para. 79 of the Treatise, 2nd edition, and the important type of intermediate limes has been altogether omitted.

* These remarks refer to the 1st and 2nd Editions. In the 3rd Edition, later Experiments on Kunkur Cements have been recorded.—[Ed.]

TABLE A.

VICAT'S DIVISION IN TYPES OF HYDRAULIC LIMES AND CEMENTS.

Principal components.	1	2	3	4	5	6	7*	8	9
	Type of slightly hydraulic limes.	Type of ordinary hydraulic limes.	Type of eminently hydraulic limes.	Type of limits or intermediate limes.	Type of cements inferior limits.	Type of ordinary cements.	Type of superior cements.	Type of cements superior limits.	Type of beginning of puzzolanas.
<i>Unburnt Stone.</i>									
Carbonate of lime,	89	83	80	77	73	64	55	39	16.4
Clay,	11	17	20	23	27	36	45	61	83.6

* Type 7 is not from Vicat, in whose time the best type of cement had not been yet ascertained.

TABLE B.*

GIVING THE CLASSIFICATION OF KUNKURS ANALYSED AT ROORKEE.

Names of kunkurs.	Carbonate of lime.	Clay.	Classification by Table A.
Ghazepore kunkur,...	72	28	Type 5, cement inferior limit.
Lucknow, No. 1, ...	72.3	27.7	" " "
" No. 2, ...	70.2	29.8	" " "
" No. 3, ...	67.7	32.3	Close to type 6, ordinary cement.
Saharnpore, No. 1,...	57.18	42.82	" " 7, superior cement.
" No. 2, ...	79.33	20.67	Type 3, eminently hydraulic lime.
" No. 3, ...	78.54	21.46	" 4, bordering the intermediate limes.
Allahabad, † ...	52.80	47.20	" 7, close to superior cements.
Delhi, No. 1, ...	53.49	46.51	" " "
" No. 2, ...	28.97	71.03	Between types 8 and 9.

Vicat and also Gillmore (whose work is a resumé of all the modern experience acquired in England, America, and France on limes and cements*)

* The classification given in Table B. is based only on the elementary analyses of raw materials, it requires therefore to be confirmed by the experiments described in page 122.

† From information received from Allahabad, it is ascertained that the Allahabad and Delhi kunkurs are very inferior. This fact might have been deduced from Dr. Murray Thomson's analyses, which show that the proportion of silica being very great, the clays and consequently the burnt kunkurs which contain them are very inferior.

are the authorities on whom are based the opinions expressed in the preceding pages. Natural cement being almost exclusively used in the United States, there cannot be a better guide for the Engineers of this country, than the excellent book written by General Gillmore, and alluded to before. For the opinions which are about to be brought forward on the manufacture of artificial cement, the arguments will rest on the very able report of Colonel Brownlow, R.E., dated 11th August, 1870, on the recent works of the English and German Engineers and cement makers, Messrs. Henry Reid and A. Lipowitz, and also on General Gillmore's works.

When Colonel Brownlow wrote his report, he must have thought that the value of kunkur as a cementing material was not sufficiently known, as he recommended in para. 9 of his report that samples of burnt kunkur should be made with view to try their power of tenacity. This power has not been yet tested, but the resistance to pressure of one kind of kunkur cement has been tried in various ways, and the results will be found in Table C. After 38 days, unrammed, Bathala cement was crushed by 0.38 tons, or 860 lbs. per square inch: and after 34 days, rammed Bathala cement was crushed by 1520 lbs. or 0.68 ton. It is therefore equal to Roman cement, according to Colonel Brownlow and other writers.

The problem put forward by Col. Brownlow, viz., that of making a cement the strength of which should be about one-third the strength of Portland cement, has been therefore solved without entering upon expensive experiments. We might therefore stop here, and think of nothing else but the study of our varieties of kunkur cements, and the improvement of their qualities; we should not then be in a worse position than the United States, where according to Gillmore, natural cements are almost exclusively used. But since the improvements in artificial cement making, introduced lately in Germany, it has become possible to make Portland cement wherever "marl clay" in the absence of chalk, and "potter's clay" in the absence of river clay are to be found, it has been thought advisable, although not absolutely necessary, to begin initiatory experiments on artificial cement.

Colonel Brownlow thought that the cementing material which we might make of slaked lime and clay, would not possess greater tenacity than one-third of Portland cement; this opinion is confirmed to some extent by all authors who agree in classing such cementing material amongst the hydraulic limes, and not amongst the cements. In such a case

therefore, we would gain nothing by trying to make it. Besides, the possibility of making and using such double kilned hydraulic lime, has been tried in many places in India, and very successfully carried out at Kurra-chee. We would, therefore, have only to walk in the footsteps of Mr. Price, to produce an equally good hydraulic lime. One point, however, remains doubtful with regard to the degree of combustion to which that lime should be subjected. It has, as yet, been burned only to the same extent that natural hydraulic limes are burned: perhaps a superior degree of combustion causing incipient vitrification would make it a cement. This should be tried, but it is of much less importance than the making of Portland cement with the marl and clays of localities far away from the sources of stone lime.*

The great difficulty in the way of making cement is foreseen in para. 16 of Colonel Brownlow's report, where the high degree of heat necessary to produce a commencement of vitrification, and the various fuels at our disposal are spoken of; coal and consequently coke are not to be had in the Punjab. The dearness of charcoal places it beyond our reach, wood according to English experience will not do in the ordinary kiln, while the oopla, which is first rate for burning natural cements in the ordinary rough conical clamps, fails completely to burn artificial cements in the same clamps, and does not even burn natural cements well in the ordinary perpetual kiln. If we had, therefore, to employ the kiln used in England for burning Portland, it is not likely that we should succeed in making that cement. But Americans, are now using perpetual flame kilns in which wood may be used as a fuel, and in which some cements are overburnt. In these kilns the fuel is not mixed with the raw material, but is supplied to two or more furnaces placed at the base, and which are arranged in such a way that the flames converge and meet in the centre of the kiln. The hole through which the burnt material is drawn, is not on the same side as the furnaces, so that there can be no admixture of ashes with the cement.

* The writer of this paper must not be understood to say that the double kilned hydraulic lime should not be adopted anywhere. He believes on the contrary that there are places in India where it would be advantageous and economical to make it: moreover he thinks, that as our wealth in kunkur shall be quickly exhausted by road making, the double kilned hydraulic lime is likely to be the cement of the future. What he means is, that he considers the feasibility of such lime as a settled question, and that all we have to do is to improve on the present manufacture. The problem of cement making which he has in view is to make artificial cement wherever marl, clay and wood are to be had, wherever he could dispose of a small water power with which he could use the rough native mills somewhat improved. If this problem was solved, small factories could be got up at a small expense in the vicinity of important works, and the great cost of carriage would be thereby saved.

The raw material alone, and not the fuel, has to be taken to the top of the kiln, which makes a great saving in labor. More information than can be given in this report, is to be found in Gillmore's treatise, from para. 237 to 258. The design for the kiln which has been constructed is based on this treatise. The plan, elevation, and section of the kiln, are given in *Plate XI*.

The question of burning having been so far settled, the following question occurs, viz., which of the two methods the English or the German, the wet or the dry, method of mixing the ingredients ought to be adopted. The advantages and disadvantages of both methods are very impartially considered in detail by the English Engineer, Henry Reid in Chap. V. of his work on Portland Cement, and it appears that space, time and labor are greatly economised by the dry system. The most important of the advantages of this last mentioned system is the getting rid of sand by dissolving it with an "alkali," whereas by the wet system, sand has to be extracted mechanically from the mixture by washing and deposition. The dry method will therefore be adopted for the experiments.

In a few words, the manufacture will be carried on in this way. Bathala kunkur and the clay in which it lies, will be (in the absence of all others in the vicinity of Runiah) the ingredients chosen. These will be broken into small fragments, dried, ground in hand-mills until they can pass through a sieve of 60 meshes to the inch. The ingredients will be then analysed and mixed so as the mixture may contain 55 per cent. "carbonate of lime." The mixture will be passed through the mills again, then mixed with $\frac{1}{3}$ rd of its bulk of water, and made into small balls or little bricks. These balls will be sun-dried, for one day only, and then placed in the kiln, where they will be submitted, at first to a very low fire to complete the drying, and then burnt until a commencement of vitrification takes place.

One hole is made in the kiln through which samples of the material can be drawn and studied at various stages of burning. The times for drawing the burnt material will be fixed according to the way in which the kiln is found to act. The burnt cement will be broken to pieces by hand labor, and ground in hand-mills, until it can pass through a sieve No. 60 mesh. It will then be spread on a dry floor for about a week, after which time it will be moulded into bricks, as recommended by Col. Brownlow, and made also into little blocks, so that the power of tenacity

of the cement after seven days in water, and its power to resist compression and a transverse strain after forty days, may be ascertained.

In the above description, the alkali part of the dry process has been neglected, for the presence of sand is not to be apprehended in the materials to be used. The alkalies are said by General Gillmore to play an important part in the hydraulic induration. In para. 591 of his book, he says that "he presumes that the alkalies, particularly the potash, act by first dissolving the silica, and then transferring it to lime, at the same time that the water acts by dissolving the lime, and carrying it to the silica." He states also that all the American cements contain more or less of the alkalies, sometimes caustic, and sometimes in the form of chlorides of sodium or potassium, and that these chlorides are present in their best natural cements. The German Engineer, Lipowitz, has the same faith in alkalies, he recommends mixing some carbonate of soda or potash with the water used, when the quantity present in the ingredients is not sufficient: but contrary to General Gillmore's ideas, he does not recommend the use of chlorides of sodium or potassium, because his experience teaches him that all cements containing chlor-alkalies suffer most from the effects of the weather.

As the alkalies seem to be absent from our kunkurs, and many other cements, it is presumed that their presence is not absolutely necessary. The alkali part of the dry process will therefore be set aside unless, as before stated, it is necessary to dissolve the silica in the state of sand present in the mixture.

PART II.—So far back as 1816, Vicat made the piers of the bridge of Souillac with rammed *béton*, but it is only of late that *béton* has begun to find some favor in England. The cause of this is, that concrete instead of being made, like *béton*, of well slaked, good hydraulic lime, was made of unslaked lime, the expansion of which while slaking must have destroyed the homogeneousness of the concrete. The custom of using unslaked lime is said by Henry Reid and Gillmore to be getting into disrepute in England, it would therefore be of some advantage if the definition of concrete given by the "Roorkee Treatise" was modified,* such definition having become obsolete. (Roorkee Treatise, Vol. I., para. 123).

Concrete or *béton* might be defined as a masonry composed of an inert material, gravel, broken stone, broken kunkur or broken bricks, cemented

* It has been modified in the 3rd Edition, *q. v.*—[ED.]

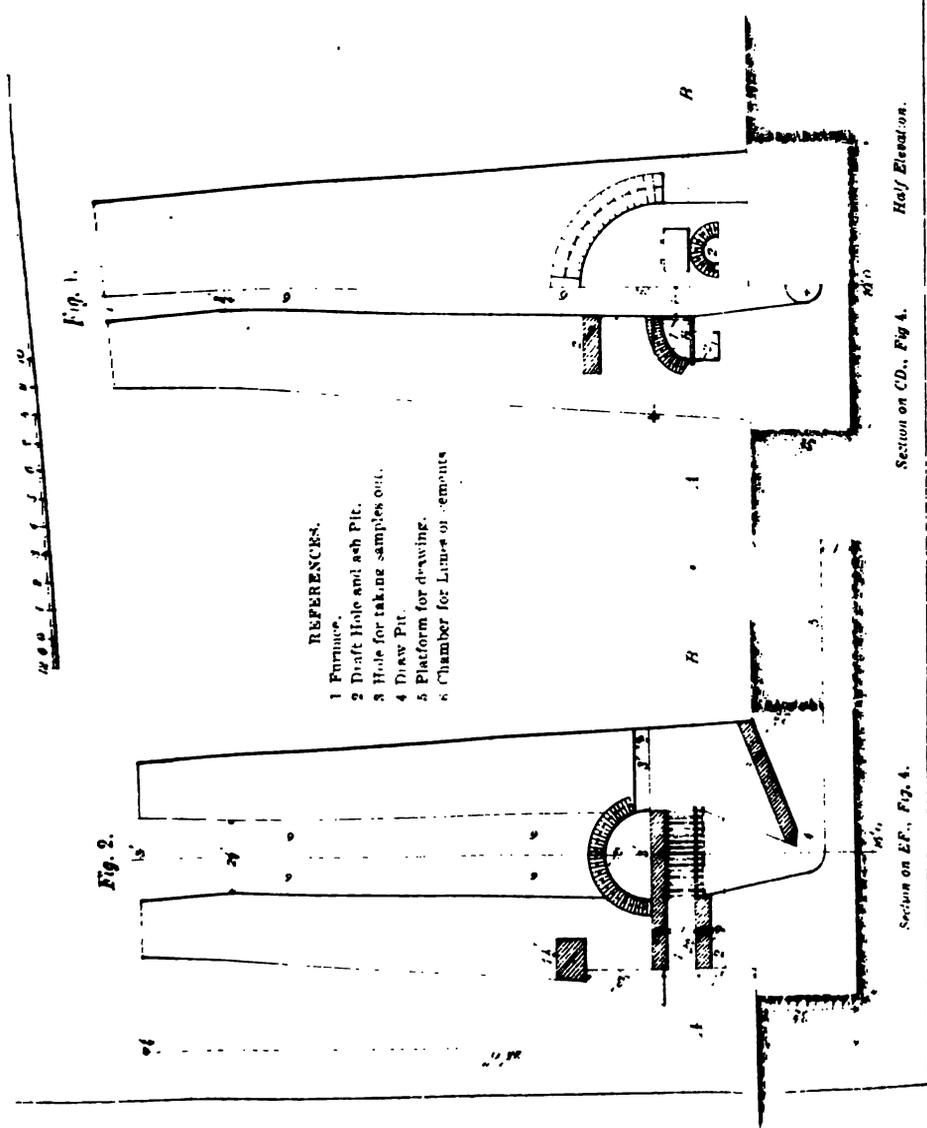

Fig. 1.

Fig. 2.

REFERENCES.

- 1 Furnace.
- 2 Draft Hole and ash Pit.
- 3 Hole for taking samples out.
- 4 Draw Pit.
- 5 Platform for drawing.
- 6 Chamber for Lime or cements

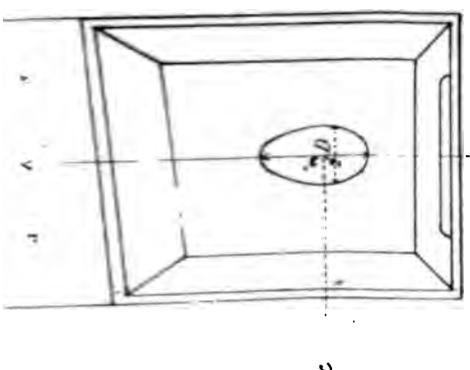
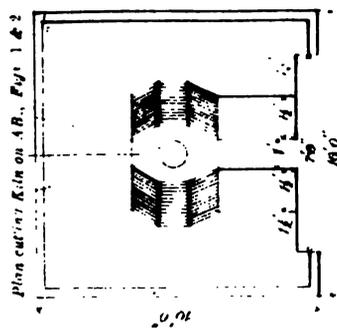

Fig. 3.



Section on CD., Fig. 4.

Section on EF., Fig. 4.

100 1 2 3 4 5 6 7 8 9 10

by a hydraulic mortar which may or may not contain sand; and with which has been mixed just as much water as is necessary for the chemical hydration of the lime: chemical affinity being called into action by that hydration, the cohesion of the mass is completed by some kind of pressure which brings the inert materials in close contact and favors their being enclosed and held together by the crystallising or setting cement. Incessant blows of rammers has been as yet the only kind of pressure employed.

The proper volume of mortar or "gang" necessary to cement the inert materials is found by filling one measure (one cubic foot for instance) with that material, and pouring on it from a graduated vessel the quantity of water necessary to fill the intervals; this volume of water gives the volume of gang just necessary to cement the inert material used. The volume so obtained ought to be increased by about 10 per cent.

From the above definition we learn that the elements of perfect concrete are—

- 1st. The best of the inert materials.
- 2nd. The best of cementing materials or gangs.
- 3rd. The exact quantity of water chemically required for the hydration of the hydraulic lime or cement.
- 4th. Accurately measured relative quantities of inert material and gang.
- 5th. Perfect mixture of the ingredients.
- 6th. Perfect ramming, which must fulfil many conditions.

It seems, therefore, from what precedes that making perfect concrete is not a work so unscientific as it has been thought to be by Engineers, who, having very good cementing materials at hand, succeeded in making good monolithic structures without troubling themselves about the other important elements of best concrete work. It is true that if the cementing material in a monolithic masonry be superior, a strength much beyond the requirements may be obtained, although the excess of water of hydration, imperfect mixture and inferior ramming, (which if carried to perfection are the most expensive parts of the process,) may have left the work so porous that rain-water could percolate through it (*see R.E. Papers for 1871, Vol. XIX., page 5*). Time alone will show whether it was safe to construct such porous masonry. As a fact bearing also on the question, we may state the rejection by the London Board of

Works of the Coignet system of manufacturing stones, a system which is nothing else than an attempt to perfect concrete. When Coignet offered to work for the Board he had already made more than 20 miles of sewers in Paris and many other works of importance, so his system had been proved excellent. However the Board, being able to make its porous, but very strong Portland cement concrete at less than half the cost that Coignet could make his concrete stone, rejected his offer (Henry Reid on Portland Cement, page 69). Coignet might have reduced the cost of his concrete by using only good slow setting Portland cement and increasing the proportion of sand, while the Board might have decreased the porosity of its monolithic masonry by adopting Coignet's ways of hydrating and ramming.

The leading principles in the manufacture of concrete having been thus explained, the results of experiments on specimens of béton made with Bathala kunkur cement, burnt, unwashed, as gang, will be proceeded with. If reference is made to Table C., three sets of results obtained at three different epochs, will be found; at the first trial, in which the specimens are marked dry, because they had been about one week out of water, the crushing weights exhibit this, as yet, unnoticed fact that, with the exception of sand and broken bricks, the inert material mixed with the cement did not weaken it. Another fact, noticed in the previous report, is that the ground mixture of bad sand and cement (a new way of treating cement and sand invented to utilise the bad sands of the Punjab, full of slates of mica) which exhibited such strength afterwards, here gave the lowest weight as if to show its slow setting activity. It will be very interesting to find out whether the grinding of the mica slates and subsequent long immersion of the specimens in water favors the combination of the alkali contained in the mica with the fine particles of sand, and the consequent partial silicization and induration of the specimens.

At the second trial, made also on dry specimens, the neat cement shows a great increase in strength and takes the first rank, although exhibiting only a little more power than the specimens of cement mixed with broken kunkur and with broken boulders. The ground mixture of bad sand and cement begins to show its superiority over the unground mixture, and obtains a crushing weight not much below that of the best specimens. After obtaining the crushing weights of the dry samples, as it was supposed that wetting them weakened their power, one specimen

of each kind was crushed when thoroughly saturated with water, and the results were such that it was decided to make all future experiments on wet specimens. The specimens of bricks crushed had been kept six months under water and then dried.

At the third trial, the dry specimens were few, but as far as the question of ramming is concerned, they bring conclusive evidence of its effect, more will be said about them further on. The crushing weights of the wet specimens show almost equal powers in the samples III., IV., VI., VIII. The mixture of cement and broken boulders seems to be slightly the best, while results obtained from many of the above-mentioned samples reached one ton per square inch. The ground mixture of bad sand and cement shows its superiority to the unground mixture, and proves that the process of grinding improves the strength by 50 per cent., and brings the ground mixture nearly to the standard of the best specimens. The samples of bricks had been kept 24 hours under water.

After these general remarks, the Table C. will be examined under the different heads of—

Inert materials,
Mortar,
Hydration,
Mixture of ingredients,
Ramming,

some suggestions being added to the results given in the various tables of experiments.

The best of our inert materials appears to be split boulders; the cause of this can be thus explained, that kunkur being much weaker than crystalline stone, a mass of fragments of hard stones, resting well on each other and well held together, is likely to have a greater strength than a mass of fragments of kunkur equally well held together. The weakest of the inert materials is broken bricks, but this would give also very good results if fragments of bricks in an incipient state of vitrification were employed. The inert materials should be well soaked in water before being mixed with the gang, and it would improve them if they were soaked in a solution of water and cement. The proportion of two inert materials to one cement answered well, but as the size of inert materials differ greatly, the proper proportion must be found as recommended in page 129 of this report.

Neat cement made the strongest mortar. If the cement employed is

fast setting and cannot be therefore prepared beforehand, the setting activity may be retarded by the mixture with it of an equal volume, or less, stone lime, or by grinding with the cement an equal volume, or less, rounded clean sand, full or not of mica slates. One volume of this mortar could be mixed with about two volumes of inert materials, so that in the case of sand mortar, the volume of cement used would be about one-sixth of the materials employed. This should be the lowest proportion of natural cement adopted, and it must receive the best ramming. It will be seen in examining the crushing weights given for Specimen IX., that such a kind of mortar was experimented upon, the natural cement being only two-fifteenths of the total volume. This proportion of cement was too small for works subjected to much strain, and the crushing weights slightly exceed only half a ton per square inch.

The quantity of water required varies extremely according to the state of the weather, and according to the age and quality of the cement. Judging the quantity of water required, is an affair of habit which an intelligent workman may perform well after a little practice. The wet gang must appear quite incoherent, and if a handful of it is taken in the hand and pressed, it must show some cohesive force without leaving dampness in the hand. If a fast setting cement is used, just the quantity required on the moment should be hydrated. The wetted mixture must be well sheltered.

On small works hand labor may be employed for making the mixture, but on extensive works it is advisable to use a pug-mill, when sand and cement only are used; and the "bètonniere" when an inert material of some size is employed with the gang.

In the definition of concrete it has been shown what sort of action the pressure of the rammer exerted on the mass acted upon. One of its well known effects is to increase the specific gravity of the material rammed, and consequently its power to resist pressure. The ramming should be therefore carried on until the ultimate specific gravity and highest strength are obtained. Practically however the general rule adopted is to stop the ramming when the surface rammed is hard enough to resist the pressure of the finger. Table C., and the last column of Table E., contain many proofs of the effect of ramming. In Table C., at each trial, the rammed cement shows a strength nearly double of the strength of the unrammed cement, and when a European takes the rammer in hand, to show the

native workman how to work, he imparts to the specimen he is acting upon a strength nearly seven-tenths higher than the greatest strength obtained by the native. Ramming which can make a specimen seventeen months old, composed of natural cement and raw kunkur in the proportion of 1 to 2, equal to specimens of Portland cement and sand, also in the proportion of 1 to 2 and nine months old, ought not to be neglected. General Gillmore compressed the specimens on which he made his experiments with a power equal to 32 lbs. per square inch. This power cannot be reached by ordinary manual ramming. The rammers used at Algiers by convicts weighed 24 lbs., with a surface of about 24 square inches, falling from a height of about six inches, they gave a pressure of about one and a half pound per square inch, no account being taken of the power of the workman who having such weight to work with for several hours could do no more than lift it. Using such heavy rammers for concrete making is not advisable in India, and 10 lbs. is about the mean weight which agrees best with the strength of our coolies and with steady and intelligent ramming. These 10 lb. rammers lifted to a height of about 12 inches, and driven down with some force, give the highest result to be obtained by hand labor, but this is far from the pressure which would make our concrete attain its ultimate specific gravity. In the case of concrete block masonry, mechanical ramming or compressing could be contrived and substituted for direct manual ramming, but in the case of monolithic arch masonry, the difficulties re-appear, and ramming must be to some extent neglected, the loss of strength being then redeemed by the use of the very best cementing material.

As a part of the question of ramming comes that of good joints. The less the water used to hydrate the cement, the greater is the difficulty of making good joints. When the minimum of water is used, the surface just rammed having attained great hardness must be thoroughly scratched to ensure its being well intermixed with the next layer. The wetter the surface rammed is, the softer it is and consequently the less scratching is required to bring about the thorough joining of the two layers. It should be remarked here that the use of fast setting cement is dangerous for the joints, as the surface rammed quickly sets, and the scratching of it destroys the setting action and weakens the concrete just at the joint.

Some comparisons will now be drawn between our results and those given in the other tables. The only comparisons that we can establish between the crushing weights given in the Tables C. and D. are those in

which neat cement or cement and sand are concerned. Looking at the result given by the dry Specimen III. of the second trial, age six and a half months, and the crushing weight of neat Portland cement at six months, it is found that nearly half the strength of Portland cement has been attained by our natural cement, and that the ground mixture of two cement to three sand is stronger than one Portland cement to four sand; it is found also that our neat cement at six months has attained the strength of Portland stone, which is greatly exceeded afterwards by Specimen V. of the third trial.

If the Tables C. and E. are now compared, it is seen that our crushing weights can bear comparison with those of most of the calcareous stones used in France for building. Table E. shows also that the ultimate limits of resistance to crushing that we should wish to attain lies between two and two and a half tons per square inch.

The Coignet system of manufacturing stones, which was said to be an attempt to perfect concrete will now be described. The stone is composed of eminently hydraulic lime and sand, or if that lime is not procurable of the best lime to be had, cement and sand. The proportion of cementing material to sand varies from 1 to 2 to 1 to 3. English Portland cement is used in preference, but it is employed only with the object of improving the lime, so more lime than cement is introduced in the mixture. One of the objects being to produce a strong stone whose external appearance is pleasant to the eye, and imitates natural sandstones as much as possible, gray quartzose sand from 1-23rd to 1-16th of an inch thickness are alone employed, yellow argillaceous sands being avoided. No gravel, pebbles or very coarse sand are used, for each would give a coarse appearance to the stone, would necessitate the employment of iron moulds and might injure the pug-mill. The materials are first mixed on the ground by shovelling, and then thrown in the pug-mill together with a certain amount of water which is variable, but which gives to the stone paste the appearance of an incoherent sand mortar. Since to obtain a perfect mixture the materials have to pass two or three times through the pug-mill, this part of the process cannot be considered as perfection, and there are pug-mills which could perform a perfect mixture in one operation. The hydration performed by foremen accustomed to the work is so near the correct thing, that water does not ooze out of the surface rammed, and does not cause any cohesion to take place between

the stone and the faces of the mould. Such cohesion always brought on by the access of water spoils the external appearance of the stone, which if taken too soon out of the mould, is sure to leave part of its sides and angles sticking to the faces of the box. The prepared stone paste is stacked, covered with a wet cloth, and gradually carried to the moulds in which it is rammed in thin layers of about half an inch for fine stones, but for monolithic masonry, the thickness is much greater. The surface is rammed until it is hard to the touch, it is then scratched with an iron rake, the next layer put in the box, where it is distributed as evenly as possible with the hand, after which the ramming is resumed.

The rammers are made of strong wood, shod with iron, the ramming surface being about $9 \times 4 = 36$ square inches. Their height is one foot, and their elevation prevents the appearance of a trapezoid, the parallel sides being respectively 9 and 4 inches, and the non-parallel sides being slightly curved. For slanting surfaces, rammers, 3 inches high, with ramming surfaces 12×7 inches and oblique handles are employed. The moulds are made so as to be easily taken to pieces, they stand on a platform, which is firmly resting on a layer of sand at least 6 inches thick. The sand effectually checks the vibration caused by the blows of the rammer, and when the fresh stones are turned on the yielding sand, they do not run any risk of being damaged. The ordinary stones are taken immediately out of the mould, the finest are kept one night in it, they are left for a week in the shade, and water is sprinkled over them twice a day from the second day after manufacture.

It is easy to infer from what precedes, that Coignet has done everything that he could to produce a concrete stone strong, and of fine appearance. His preference for eminently hydraulic limes shared by many French Engineers comes, it is presumed, from its relative cheapness, and from the fact that it is yet a matter of uncertainty whether the eminently hydraulic limes do not give as good results as the best cements, they are certainly much more safe to use than the fast setting natural cements. His reason for preferring good sand to any other inert material has been explained. It is especially by using a minimum of water and ramming thoroughly, that he succeeded in making stones possessed of a minimum of porosity, or in other words, a minimum of specific gravity, a great advantage when the dissolving action of rain water charged with carbonic acid is taken in account. Coignet might

have further improved his system by making his stone with machinery; but with the help of European workmen, with plenty of cheap and good slow-setting cementing materials and in the mild temperature of Europe, he succeeded so easily in making fine monolithic masonry and reliable joints, that it is presumed he could not see the necessity for using on a larger scale, blocks of concrete made by machines. The circumstances in which we are placed in India being very different from those in which Coignet was placed in Europe, the advice of Henry Reid to rely only on block masonry should be adopted for large and important works, monolithic masonry being used only for minor work, the surface exposed to rain water being well cemented to prevent percolation.

TO RECAPITULATE.—In the first part, the various degrees of wetness of mortar under different circumstances have been examined; the importance of the classification of our burnt kunkurs has been pointed out, and practical ways of finding out the class to which each particular burnt kunkur belongs have been given; lastly the question of artificial cement is considered in some of its details, and a short description of the manner in which the experimental manufacture will be conducted is detailed.

In the second part the qualities of the various inert materials and the way to utilise the bad sand of the Punjab have been shown; the dangers accompanying the use of fast setting natural cements are indicated, and various ways of retarding their setting activity have been given; the effects on the specific gravity of the concrete resulting from the degree of hydration, and from the degree of ramming have been pointed out, many unknown precautions attending good ramming, making good joints and handling blocks have been detailed; an endeavour has been made therefore to explain everything which was yet obscure and undefined in the theory and practice of concrete making.

A. N.

TABLE D. Showing the results of experiments on Portland Cement, conducted by Mr. Grant, Engineer of the Metropolitan Board of Works, London. Portland Cement (compressed not rammed). Bricks and stones.

Composition of specimens.	Age in months.		Crushing weights In tons per sq. Inch.		Age in months.	Crushing weights In tons per sq. Inch.		Names of specimens.	Crushing weights In tons per sq. Inch.	
	3	6	2-40	2-66		9	2-03		1-01	1-17
Neat cement,	T 1-70	6	2-40	2-66	9	2-03	1-01	Portland stone on bed, ..	1-17	
1 vol. " 1 vol. sand,	1-12	..	1-54	2-0342	" against bed,	1-07	
1 " 2 "88	..	1-22	1-62	1-79	Bramley Fall stone on bed,	2-37	
1 " 3 "62	..	.96	1-0774	" against bed,	1-30	
1 " 4 "60	..	.81	.99	1-86	Yorkshire landing on bed,	2-50	
1 " 5 "41	..	.68	.75	2-07	" against bed,	2-61	

TABLE E, Translated and reduced to English measures from the *Manual Des Ponts et Chaussées* (Encyclopedie Roret) showing the weights required to crush instantaneously various stones, bricks and mortars.

Names of Stones.		Specific gravity, water being = 1.	Crushing weights in tons per sq. inch.	Names of stones.		Specific gravity, water being = 1.	Crushing weights in tons per sq. inch.
MARBLES.				CALCAREOUS STONES.—(Continued).			
Porphyry,	2.87	9.40	Chatillon rock, near Paris, soft,	2.08	.85
Flander's marble,	2.63	6.62	Arcueil rock, near Paris,	2.80	1.62
Genoise	2.70	2.28	Yellow oolite of Jaumont 1st quality,	1.15
Flander's black marble,	2.72	5.04	" " 2nd quality,76
White marble with veins,	2.70	1.91	" " d'Amavillers, 1st quality,76
" " for statuary,	2.69	2.09	" " 2nd quality,64
" " Turkish,	2.67	1.96	Hard rock of Saulny, near Metz,	1.72
" " Italian with veins,	2.73	4.07	Yellow rock of Rozwecilly, near Metz,	1.15
" " Brabant	2.70	4.18	Blue calcareous stone giving the hydraulic lime of Metz,
Red " from Devonshire,	8.31	Sandy calcareous stone,	1.72
CALCAREOUS STONES.				Oolitic60
Calcareous stone of Givry, hard,	2.36	1.97	Compact " lithographic,	1.84
" " soft,	2.07	.71	Saillancourt stone, Ponton, 1st quality,	2.41	.90
White " Tonnerre,	1.71	1.20	" " 2nd quality,	2.29	.58
Cassite stone, near Naples, can be polished,	2.72	3.80	" " 3rd quality,	2.07	.57
Black stone of St. Fortunat, near Lyon, very hard shelly,	2.65	4.00	Comfians stone, near Paris,	1.82	.35
Calcareous stone of Jura,	3.00	3.84	" " soft,	1.92	.45
Lias of Bagneux, near Paris, very hard and fine grain,	2.44	2.84	Plaster stone of Montmartre,
" "	2.36	1.90	GRANITES.			..
Travertine of Rome, very hard and fine grain,	2.29	1.10	Green granite of the Vosges,	2.85	3.96
Chatillon rock, near Paris, hard,	Grey " Brittany,	2.74	4.80
				Granite of Normandy,	2.66	4.49

Names of Stones.	Specific gravity, water being = 1.	Crushing weights in tons per sq. inch.	Names of Stones.	Specific gravity, water being = 1.	Crushing weights in tons per sq. inch.
GRANITES.					
Gray granite of the Voeges,	2.64	2.70	St. Ammersmith,45
Blue " Aberdeen,	2.62	4.95	Overburnt brick,65
Compact " Peterhead,	3.76	Red "	2.17	.86
Granite of Cornwall,	2.66	2.88	Light red "	2.08	.23
			Raw "21
QUARTZ ROCK.					
Very hard quartz,	2.52	5.2	MORTARS.		
White "	2.48	5.91	Mortar of fat lime and sand, 14 years old,12
			" hydraulic lime,46
			" eminently hydraulic lime,92
SILICEOUS STONES.					
Siliceous stone of Dundee,	2.58	3.0	Mortar of lime and river sand,	1.63	.19
" " Bramley fall near Leyde,	2.54	2.68	The same rammed,	1.59	.26
" " red,	2.82	2.70	Mortar of lime and pit sand,	1.99	.86
Limestone of Limerick, black and compact,	2.60	4.08	Mortar of lime and ground quartz,	1.68	.18
			" " sootkee,	1.45	.30
			The same rammed,	1.66	.48
			Mortar of lime and Naples or Rome, puzzuolianas,	1.46	.23
Stourbridge brick,78	The same rammed,	1.68	.35

T

Crushing weight of Coignet's stone made with Portland cement, from 2.18 to 4.28, according to age. (Walter L. Granville's Note on the Coignet System.)

A. N.

No. LXXIII.

RETROGRESSION OF LEVEL IN CANALS.

*Vide Plate XII.*BY E. A. SIBOLD, Esq., *Erec. Engineer, Sirhind Canal.*

Cutting back is an evil that is costly to remedy, especially if comprehensive measures are not taken to check it at the beginning. This paper only treats of irrigation canals, where it is economy to carry water at the greatest velocity that the soil and slope of the country admit of. The Ganges and Baree Doab Canals are examples of the two largest irrigating canals. The profits of both have been seriously diminished by the yearly expenditure in protecting the masonry works against cutting back.

The following theory is based on observations of the state of the bed of the Baree Doab Canal at different times, and different places, and the effects of different systems of protective works.

Given a length of earthen channel between two masonry points. If the velocity in contact with the bottom is greater than the soil can stand, cutting commences. It is evident that in a straight channel with the stream "in train," the greatest surface and bottom velocities are in mid-stream, and therefore cutting will commence there first. Every inch cut here, increases the depth at this point, and consequently the bottom velocity. With an increase of velocity and area in mid-channel, there must be a corresponding decrease of velocity towards either bank, the cutting having commenced and localized itself, it is also evident action on the line selected, is intensified in the ratio $(a + d)^2$.

In *Fig. 1*, let AB be the given length of earthen channel.

If the soil was the same in every foot between A and B, a gullet E, *Fig. 4*, would be formed in mid-channel, on a lower level, and a smaller declivity. This gullet may be represented by the line CD, *Fig. 1*. Whether

the gullet ABCD will run up to B as in *Fig. 1*, or work into slope as originally projected before reaching B, as in *Fig. 2*, will depend upon circumstances that will be referred to further on.

The difference of declivity on the line AB and the line CD, will represent the rapid that will be formed eventually on the masonry bar A.

In the above, I have supposed the quality of the soil in every foot of the channel to be the same, and the result a uniform gullet. It would be improbable that the tenacity of the soil could be the same in every portion. The consequence is that the gullet will not be on a uniform level, and the change of level wherever the tenacity varies is distinguished by a rapid, *vide a, b and c, Fig. 2*. In the abrupt change from an upper to a lower level of the gullet the stream is contracted, and the dispersion of the threads of the stream after contraction tends to scoop out a basin below.

Fig. 2, gives what may be called the second stage of cutting back; breaks in the level of the gullet occurring at *a, b and c*. At the toe of the crest of the fall or rapid at each break, we find a pear-shaped cistern or hole, formed by the fan-like dispersion of the threads of the stream on quitting the higher level.

Now take the breaks *a and b, Fig. 5*, from *Fig. 2*. If the soil at *b* could not stand the velocity due to projected slope, it could not stand the higher velocity on the rapid, and therefore in a given time the portion *bcdh* will be cut away, and the deflected threads not requiring the space *c, e, f, g*, this area will be silted up. When the point *b* recedes to the point *a* by gradual erosion, and *a* again to the bar A above the bed between A and B, *Fig. 3*, may be said to have acquired permanently the declivity best adapted to carry the ordinary discharge.

The successive basins formed during the retrogression of *b* to *a*, by necessarily having the axis EF, *Fig. 7*, much larger than the width of the gullet, serve to widen the channel on the lower bed; otherwise channelling would simply wear a semi-circular section in the projected bed. These holes therefore so far from doing mischief are very useful, for they check the tendency to a semi-circular section, which with large bodies of water, would require that nearly every inch of fall should be provided for by masonry overfalls.

On the Barea Doab Canal the first appearance of retrogression was distinguished by a slight deepening of channel usually in mid-stream, and soon after by small rapids at various points, and by the scouring out of

HOWING RETROGRESSION OF LEVEL ON DIFFERENT REACHES OF THE BAREE DOAB CANAL.

Horizontal Scale 50,000 = 1.
Vertical Scale 120 = 1.

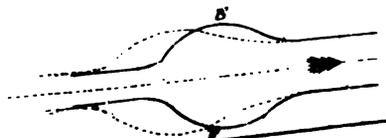
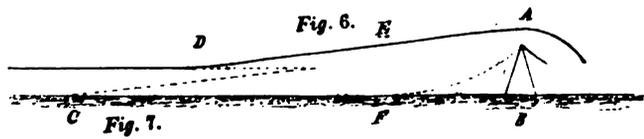
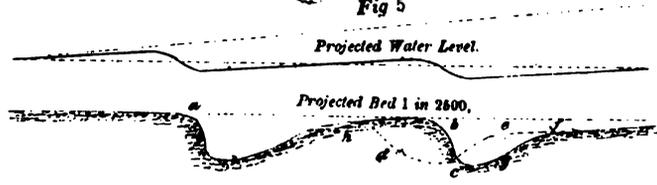
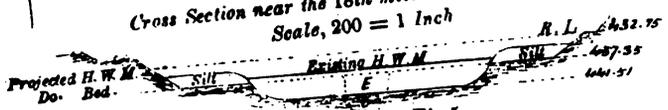
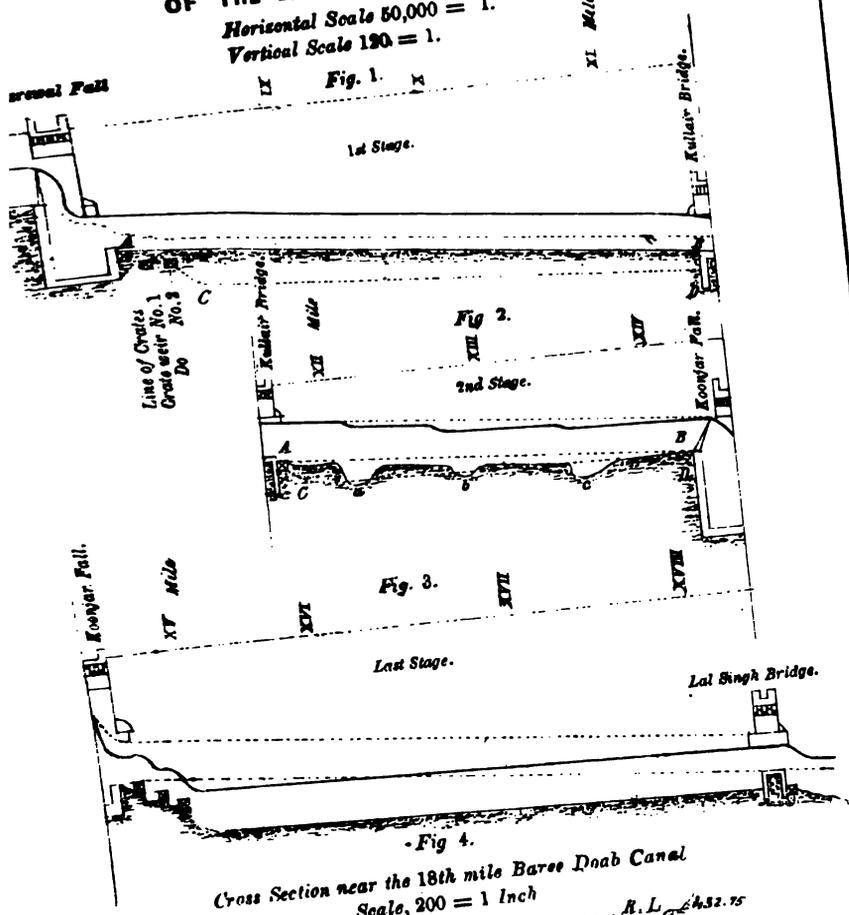

large holes. Fascines, kiln refuse, lines of stakes, wattling, and large trees were tried year after year, but nothing appeared to check the retrogression of level. Wherever the minor rapids have worked back and formed one large rapid at the up-stream masonry bar, these holes have silted up, and there is now a uniform bed on a lower level as C, D, *Fig. 1*. The scouring out of holes is only an accident due to the formation of rapids, and it is only a waste of money to try and check them.

My observations show that the holes do less good where there is a stratum of kunkur or a tenacious soil. It is almost a paradox, but channeling appears to be most formidable in good soil. The soil of reach shown in *Fig. 3*, is better than that of *Fig. 1*, yet the retrogression in the former is 6.9 feet, and in the latter 3.2 feet. In light soils the sides fall in, and prevent the tendency to a very deep stream. There is an example of this in the reach above Dharewal fall, the soil here is much worse than that of *Figs. 1 and 2*.

The following will probably give the key to the above paradox. The dimensions of section *Fig. 4* are—

Width of bed, 84 feet.

Side slopes, 1.5 to 1.

Depth of water, 5.0 feet.

Declivity, 1 in 2,500.

A semi-circular channel of the same area will give the same discharge on a declivity of 1 in 9,338. That there is a difference is of course well known, but its importance has been, I think, overlooked.

In both cross sections we have the same area, and the same discharge, so it is evident that the mean velocity must be the same. At the same time the range between maximum and minimum velocities in the right lined section is more, and in the semi-circular section less, therefore the mean velocity in the latter section would be a safer guide to estimate effect on bed than in the former.

With reference to *Fig. 1*, it was left undetermined whether D would vanish or not at B. It will vanish at B if the declivity below B is not so sharp as to cause a draw, or if there is a properly constructed overfall at B. If in channel BC, *Fig. 6*, a weir is built, it is a mistake to suppose that the water in prism ABC is dead. Any change from a higher to a smaller velocity causes dispersion, and a contraction of the stream takes place on the velocity being increased. The weir AB causes dispersion

at D and contraction at A, so that D, E, A, F represents running water.

If the theory of retrogression of level is correct, the adoption of intermediate overfalls to arrest it would require such overfalls to be *high* enough to practically convert the several reaches of a canal into still water reservoirs. Such an expedient would obviously be very costly, and especially so in lockages, if navigation had to be provided for.

E. A. S.

ROOPUR, }
March 4th, 1878. }

No. LXXIV.

QUANTITY OF WATER FOR VARIOUS CROPS.

Report on Experiments for ascertaining the quantity of Water required for Irrigating various Crops in Rajpootana. BY W. W. CULCHETH, Esq., C.E., *Exec. Engineer, Beawar.*

Report on the observations made on Irrigation from Wells at Beawar during the cold season of 1871-72.

April, 1872.

THE observations were commenced in October last, when irrigation for the rubbee first began. Two wells were selected at a convenient distance from the city for observation. One was worked by a churrus or mô't, and the other by a Persian wheel. The accompanying statements (three in number) contain the results of observations.

A careful man was employed all through the season to count the number of mô'ts in one case, and the number of hours of working in the other, and to note the area each day irrigated. The latter was checked at the end of the season, by measuring the whole area, and multiplying it by the number of waterings.

The discharges were measured by means of an iron cylinder, near the bottom of which are three holes of different sizes. The middle one, which was used in these observations, is 1.64 inches in diameter, and the average head of water above centre of orifice was 10 inches for the churrus, and 12 inches for the Persian wheel. By D'Aubuisson's formula, $D = 8.9066d^2 \sqrt{h}$ the discharges are .067 cubic feet per second for the mô't, and .073 cubic feet with the Persian wheel. As there were 66 mô'ts drawn in an hour when the above discharge was measured, the

contents of each *churrus* (as far as available for irrigation) are 3.6 cubic feet. The actual contents of the *môt* and the buckets of the Persian wheel were not measured, as only the water delivered into the water-course leading to the fields was available for irrigation.

The actual areas irrigated were $19\frac{1}{4}$ beeghas by the Persian wheel, and $9\frac{1}{2}$ beeghas by the *churrus* or *môt*. A rubbee crop was grown on the former, and the same on $8\frac{3}{4}$ beeghas of the latter, while $\frac{7}{8}$ were occupied by vegetables; the two beeghas which are shown as *khureef* were afterwards used for rubbee. All the fields with rubbee were watered six times, and many of them seven times, the vegetables were watered several times and cut, after which others were put down and watered nine or ten times up to the end of March, since which the observations have been discontinued, as the rubbee crops were then being cut.

Tabular Statement, No. 1, shows a great similarity in the *average* quantity of water required per beegah for different crops. The quantity each month, however, varies, less being required in the latter part of the season, probably owing to the greater frequency of the waterings. No. 2 shows a similar result in cubic feet, and gives the depth of each watering in inches; this is very similar in the two modes of irrigation. No. 3 shows the total quantity of water used during the season and the depth.

The main object of these observations was to ascertain the quantity of water required for irrigation. From No. 3 it appears that 29,579 cubic feet were used per acre by the Persian wheel, and 36,357 cubic feet by the *môt*, or an average of nearly 33,000 cubic feet, which represents a depth of nine inches for the rubbee crops: 76,103 cubic feet were used for vegetables during the same time. Each watering was on the average $1\frac{1}{2}$ inches by both methods of irrigation, and for both crops, but more was required at the commencement of the season, and less later. This was, doubtless, to a great extent, owing to the fact of the ground becoming hard from repeated waterings.

It is not the custom to make the beds (*kyarees*) so small for tank and canal irrigation, as for well irrigation. The latter mode necessitates constant labor to raise the water as required, whereas the former generally supplies the water so as to flow over the ground in a continuous stream, without the necessity for any supervision beyond what is required to divert it into the various fields. Water from wells is obtained with difficulty, and in small quantities, and is, therefore, used with care,

whereas that from tanks and canals, flow generally in a larger stream, and requires very little labor; it is, therefore, used more freely and often wasted even. This must be considered when comparing well with tank irrigation, the same duty must not be expected from a given quantity of water stored in a tank, as from the same quantity raised out of wells.

Under these circumstances I do not think these observations will warrant less than one foot in depth, being taken as necessary for rubbee irrigation, when considering a tank project. Vegetables are seldom grown in considerable quantities, or away from a large town, and need not be taken special note of.

It may also be worth noting that, roughly speaking, one-fourth of the whole quantity of water is used during October, November and December, and one-fourth during each of the remaining months.

In conclusion, I would recommend a continuation of the observations during the next khureef and the following rubbee. The experience of the past season will be a valuable guide for the future. It would be interesting to ascertain whether the fewer waterings which are sometimes given, take less water altogether. It seems probable that each watering would be heavier, as these observations show to have been the case at the commencement of the season. One well might be selected with a view of deciding this, a not unimportant point.

No. 1.

TABULAR STATEMENT of observations on Well Irrigation at Beswar during the cold season of 1871-72 (or from October 1871 to March 1872, inclusive).

Month.	IRRIGATION BY CHURRAS OR MÔT.										IRRIGATION BY PERSIAN WHEEL.				
	FOR KHUREEP CHOP (COTTON).			FOR VEGETABLES.			FOR RUBBER.			Total.		Area irrigated each month.		TIME OF WORKING.	
	Number of days.	Area irrigated each month.	Drawn each month.	Number of MÔs.	Per beegah.	Area irrigated each month.	Drawn each month.	Number of MÔs.	Per beegah.	Area irrigated each month.	Number of MÔs drawn.	Number of days.	Area irrigated each month.	During each month.	Per beegah.
October,	10	2	1,070	585	1 1/2	942	754	2 1/2	1,993	886	5 1/2	4,005	4	38 1/2	12-88
November,	7	1	702	702	3 1/2	2,408	642	4 1/2	3,108	8	45 1/2	9-10
December,	12	1 1/2	869	696	5 1/2	3,823	665	7	4,692	14	123	8-20
January,	28	1 1/2	600	480	20	10,715	536	21 1/2	11,315	29	262	7-27
February,	26	3 1/2	1,560	480	18 1/2	8,825	471	22	10,385	23	208	6-70
March,	26	5 1/2	2,726	474	15 1/2	7,080	464	21	9,806	20	189	7-20
Total,	111	2	1,070	585	18 1/2	7,899	3,586	65 1/2	34,842	3,664	81 1/2	43,311	98	116 1/2	51-30
Average,	585	538	530	7-45

No. 2.

ABSTRACT of results of observations on Well Irrigation at Beaver during the cold season of 1871-72.

Month.	IRRIGATION BY CHURUS OR MÔT.						IRRIGATION BY PERSIAN WHEEL.						MEAN RESULTS.	
	Area irrigated each month.		QUANTITY OF WATER USED.		Depth of each watering.		Area irrigated each month.		QUANTITY OF WATER USED.		Depth of each watering.		Quantity of water per acre.	Depth of each watering.
	Beegahs.	Acres.	Each month.	Per acre.	c. feet.	inches.	Beegahs.	Acres.	Per hour.	Per month.	c. feet.	inches.	c. feet.	inches.
			Môts.	c. feet.	c. feet.	inches.			c. feet.	c. feet.	c. feet.	inches.		
October,	5½	22	4,005	14,418	6,554	179	8	1.2	10,126	8,429	2.82	7,482	2.06	
November,	4½	19	3,108	11,189	5,889	1.62	5	2.0	11,966	5,979	1.65	5,984	1.64	
December,	7	28	4,692	16,891	6,082	1.66	15	6.0	32,849	5,887	1.48	5,710	1.57	
January,	21½	85	11,315	40,784	4,792	1.82	86	14.4	68,906	4,776	1.82	4,784	1.82	
February,	22	88	10,885	37,886	4,248	1.17	81	13.4	54,704	4,402	1.21	4,825	1.19	
March,	21	84	9,806	33,802	4,208	1.16	26½	10.5	49,707	4,730	1.30	4,466	1.23	
Total,	81½	326	48,811	155,920	31,718	8.72	116½	46.5	227,768	33,708	9.28	32,711	9.01	
Average,	4,783	1.82	262.8	..	4,898	1.35	4,840	1.88

N.B.—A beegah is equal to 1,986 square yards, or two-fifths of an acre.

No. 3.

TABLE showing the total quantity and the depth of water used during the whole season, viz., from October 1871 to March 1872, inclusive.

Mode of irrigation.	Crop.	AREA IRRIGATED		QUANTITY OF WATER USED.				Remarks.
		Beegahs.	Acres.	No. of mds.	Cubic feet.	Per acre.	Depth of water used during season. Inches.	
By Persian wheel,	Rubbee	19½	7.70	...	227,758	29,579	8.15	Average quantity per acre, 32,968 c. feet.
By môt or churrus,	"	8½	3.45	34,842	125,431	36,357	10.02	Average depth per acre, 9.08 inches.
" "	Vegetable	½	.35	7,399	26,636	76,103	20.97	During six months, October to March, inclusive.

Note by MAJOR J. M. WILLIAMS, Exec. Engineer, Ajmere Irrgn. Division.

These experiments were conducted with great care, and under the immediate supervision of Mr. Culcheth, and during the period of his absence on leave by Overseer Sergeant Houghton, a most careful subordinate who held temporary charge of the sub-division.

The crops irrigated consisted as follows:—

Wheat,	5 beegahs.
Gojee,	22½ "
						27½ "
						7½ "
Vegetables,	7½ "

It will be seen from Mr. Culcheth's report that the average quantity of water per acre required for the rubbee crop was 32,968 cubic feet, and the average depth 9.08 inches, delivered in about seven waterings of 1½ inch each.

Vegetables required more than double this quantity of water, but for all general purposes of irrigation these may be left out of the account.

Mr. Culcheth explains that the beds (kyarees) in fields under well

irrigation are made very much smaller than for tank or canal irrigation, and for that reason the observations which have now been made will not warrant less than one foot in depth of water being taken as necessary for rubbee irrigation when considering a tank project.

In this I entirely concur, since the saving in water is two-fold in irrigation from wells, as compared with that from tanks:—

(1). In well irrigation the water lies on the beds of the fields, where they are of so small dimensions, forming almost a series of level terraces, so that nearly, if not all, the depth of water given to each bed is absorbed in "site" instead of rapidly running off as in the case of tank irrigation, where the divisions of the fields are generally a considerable distance apart down the slope of the land.

(2). As raising water from wells involves considerable labor, the zemindars will only use as much water as may be absolutely necessary to mature the crops, instead of letting it run to waste as constantly is the case in tank irrigation.

I consider, however, that, in other respects, the results arrived at from these observations may be relied upon, and that they really indicate the quantity of water which, under favorable circumstances, is sufficient for a rubbee crop.

The experiments must, however, be extended to tank irrigation. It was too late last year when the experiments were commenced to do this, as time was requisite to make the necessary preparations to conduct the experiments satisfactorily.

Some of the tanks in the Bulad Catchment have been contoured, and steps will be at once taken to conduct experiments on these tanks through the approaching khureef and the ensuing rubbee cultivation.

Note by the Superintending Engineer, Rajpootana.

The results are precisely those which all my enquiries on the subject from cultivators and zemindars have constantly elicited, viz., 1 foot for the rubbee, and what is not yet experimented on here, 6 inches for the khureef. This is also the result of Colonel Brooke's long enquiries and experience on this subject.

There are numerous sources of error in letting the water fall into an iron receptacle with three holes, into which the churrus rapidly pours itself,

and then entirely ceases, filling the cylinder to brim, and then letting it sink to zero.

The Executive Engineer should adopt a more correct gauge, as a masonry channel at part of the run, having a well which will contain 15 to 30 churruses and so measure these, and thus get at the lift per hour.

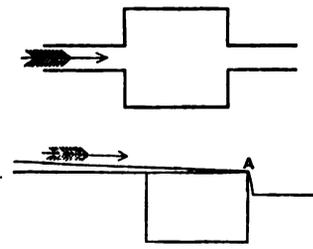

This could be again, and continually at any time of the day, checked by gauging at A with a thin-edged waste board, whilst the flow would be somewhat equalized by the water having to run along a channel and pass over the field reservoir

after leaving the churrus.

The Executive Engineer will be directed to at once arrange for a more perfect experiment both for a tank and wells, beginning with the khureef in end of June, and ending with the rubbee in March.

The results here obtained are:—In the case of well water—

- 1.—The rubbee crops required 6 to 7 waterings.
- 2.—The acre of rubbee took a total depth of 9 inches.
- 3.—Therefore each watering = $1\frac{1}{2}$ inches in depth.
- 4.—The storage required per acre = 33,000 cubic feet.
- 5.—Of which about a fourth only of *whole* supply was given during the first three months, and about a fourth during each of the last three months.

The figures per month, per acre, are in round numbers—

	Cubic feet.		Cubic feet.
October,	17,000	January,	10,100
November,	2,000	February,	8,200
December,	4,100	March,	6,900
Total, ..	7,800	Total, ..	25,200
Total, 33,000			

The Chief Commissioner says, that the reasons the waterings go further month by month is that the ground is kept moist and sheltered from the sun by the crops.

There is no doubt that for tank irrigation we must allow an increase on these figures, though, I think, 12 inches, or one-third more, is high if this experiment gives anything like correct data.

No. LXXV.

TRANSVERSE STRAIN IN PILLARS.

By CAPT. ALLAN CUNNINGHAM, R.E., *Hon. Fellow of King's Col. Lond.*

It is sometimes required to ascertain the *actual* intensity of Longitudinal Stress produced in a Heavy Vertical Pillar by the action of applied Transverse Forces.

[The ordinary Text-books do not usually contain a solution of this question, except for material whose extension and contraction under *equal* Tensile and Crushing Load respectively are equal].

The general solution of this problem depends in general on the relative powers of resistance to stretching and crushing, and does not admit of reduction to a simple algebraic form.

There is one case, however, and that the most useful, in which it admits of easy solution, viz., "when the actual stress over any cross-section is *all of one kind*"—(this would usually be Pressure)—by aid of the following Proposition, which will now be proved.

Proposition.—In a Heavy Vertical Cylindric Pillar under Transverse Strain (due to applied Horizontal Forces), the Greatest and Least intensities of the Longitudinal Stress produced at any cross-section are independent of the Tenacity of the material, so long as the actual stress is all of one kind (pressure), and are therefore *the same for all material* which is capable of bearing a "uniformly-varying" strain—provided also that the elastic limit for crushing strain be not exceeded.

[This proposition, viz., that, if there be no Tension, the Greatest and Least intensities of *Pressure* are independent of the Tenacity, and also the same for all material, seems almost self-evident. On account of its interest and importance however a formal demonstration is advisable.]

Take any (horizontal) cross-section as AB.

Let W = Total Load or Weight above AB--(which is uniformly distributed over AB, because the Pillar is "cylindric").

Vertical Section through Centre of Gravity of Pillar.

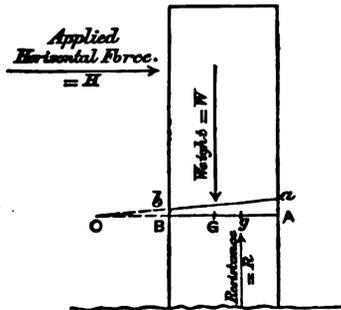

A = Area of Cross-Section AB.

p_o = Mean intensity of Longitudinal Stress over that area.

Then $p_o = \frac{W}{A}$, always—i. e., independently of distribution and amount of any Transverse (horizontal) forces,—and is PRESSURE.

The effect of applied Transverse Force is to alter the distribution of

Vertical Stress—(but not to alter the magnitude of the Resultant of Vertical Stress which remains the constant PRESSURE W):—

If the applied Transverse Force be *small*, its effect is to diminish the pressure on the near side (B), and increase it on the far side (A): this variation of pressure increases with an increase in the Transverse Force, and may eventually produce Tension on the near side :

It is proposed to limit this Paper to the consideration of the case when only pressure is produced—on account of the simplicity of the result.

It is assumed by almost universal consent of Engineers that the actual Strain (contraction of the material) is a "uniformly-varying" Strain, i.e., that the contraction at any point of the cross-section AB is simply proportional to the distance of that point from a certain fixed line, usually called the "neutral axis" in the plane AB; also that within the elastic limit the Stress is simply proportional to the Strain. Hence if O be the position in the Diagram of the "neutral axis" in the cross-section AB, the Trapezoid $AabB$ is a vertical section of the "Strain-prism", and is also a graphic representation of the Stress.

Let H = Resultant of applied Horizontal Forces.

R = Total Resistance (i.e., Longitudinal Stress) over the cross-section AB.

Let M_x = Moment of Horizontal Forces (H),
 M_w = Moment of Loads (W),
 M_r = Moment of Resistances,
 } about the "neutral axis" in cross-section AB.

G be the centre of gravity of section AB.

g be the Centre of Stress.

O be the position (in vertical section through G) of the "neutral axis" or "line of no Stress."

\bar{x} = OG, α = GA, β = GB, x_o = Og.

ω = Stress-intensity at unit distance from neutral axis.

p' = Greatest Stress-intensity (at A).

p'' = Least Stress-intensity (at B).

I = Moment of inertia of area A about the neutral axis.

I_o = Moment of inertia of area A about an axis through its centre of gravity (G) parallel to the neutral axis.

[The several units of length, weight, &c., should be the same throughout]

Then by principles of equilibrium—

$$R = W \dots\dots\dots (1).$$

$$R \cdot x_o = M_R + W \cdot \bar{x} \dots\dots\dots (2).$$

Also by ordinary rules for uniformly-varying pressure (as for fluid pressure).

$$R = \omega \bar{x} \cdot A \dots\dots\dots (3).$$

$$R \cdot x_o = \omega I = \omega (I_o + A \cdot \bar{x}^2) \dots\dots\dots (4).$$

$$\therefore \omega \bar{x} \cdot A = W \dots\dots\dots (5).$$

$$\omega I_o + \omega A \cdot \bar{x}^2 = M_R + W \bar{x} \dots\dots\dots (6).$$

$$= M_R + \omega A \cdot \bar{x}^2, \text{ from (5).}$$

$$\therefore \omega I_o = M_R, \text{ whence } \omega = \frac{M_R}{I_o} \dots\dots\dots (7).$$

But since the stress is "uniformly-varying,"

$$p' = \omega \cdot (\bar{x} + \alpha) = \frac{W}{A} + \frac{M_R}{I_o} \cdot \alpha \dots\dots\dots (8).$$

$$p'' = \omega \cdot (\bar{x} - \beta) = \frac{W}{A} - \frac{M_R}{I_o} \cdot \beta \dots\dots\dots (9).$$

Now these results (8) and (9) are independent of the "quality" of material at the section, so the Proposition is proved.

These results must therefore (being independent of the material) be the same as would be found by simply adding the uniform pressure $p_o = \frac{W}{A}$ to the Stress-intensities at opposite sides of a (weightless) Cantilever of "isotropic" material, i. e., material whose Moduli of Tensile and Crushing Elasticity are equal.

By the usual rules* for Cantilevers of "isotropic" material,

$$\text{Crushing Stress-intensity at A} = \frac{M_R}{I_0} \cdot \alpha$$

$$\text{Tensile Stress-intensity at B} = \frac{M_R}{I_0} \cdot \beta$$

Adding the uniform pressure $p_0 = \frac{W}{A}$ to each of these, there results as before,

$$p' = \frac{W}{A} + \frac{M_R}{I_0} \cdot \alpha \dots\dots\dots (8).$$

$$p'' = \frac{W}{A} - \frac{M_R}{I_0} \cdot \beta \dots\dots\dots (9).$$

The practical use of this proposition is that it enables the comparatively familiar Rules applicable to "isotropic" material to be applied to *any* material within the limit—"Stress all of one sign".

[The applicability of the Proposition in any case will of course be indicated by the results p' , p'' , which must be of the *same* sign].

The Proposition is peculiarly applicable to Masonry Structures simply set in Mortar, whose resistance to tearing apart (in a vertical direction) is generally so very small that English practice† is to place no dependence on the Tenacity of the mortar: in such structures, therefore, all Stress should (for safety) be PRESSURE, in which case the Proposition is certainly applicable.

It may be easily seen that Results (8) and (9) are *always* applicable to Pillars of "isotropic" material, (*i. e.*, whether the Stress be entirely of one kind, or partly Tension, partly Compression), because the very same original equations (1), (2), (3), (4), are still applicable; but these results are not applicable *generally* to other material, because Eq. (3) and (4) are applicable only in the cases stated, *viz.*; (1), to all material capable of bearing uniformly-varying Strain, when the Strain is all of one sign; (2), to "isotropic" material, whether the Strain be of one kind or of both kinds.

[It is supposed of course that the Length of the Pillar is not so great compared with its diameter as to make it liable to fail *by bending* under the Vertical Load alone, as the Rules for Strength of such very long Pillars are complex‡ even under Vertical Load only].

* Rankine's Civil Engineering, Art. 162.

† Rankine's Civil Engineering, Art. 263.

‡ Roorkes Treatise of Civil Engineering, Vol I., 3rd Edition, Chap. XXIII.

No. LXXVI.

MASONRY CONDUITS *VERSUS* IRON PIPES.

BY MAJOR HECTOR TULLOCH, R.E.

(From "The Water-supply of Bombay.")

As in every project for the water-supply of Bombay hitherto submitted, it has been proposed to construct the dams of the reservoirs of earth, and indeed been almost silently assumed that no other material for works of this class could be adopted, so likewise in every project has it been proposed to bring the water from the reservoir to Bombay in iron or steel* pipes, nor have any other means of effecting this object been sug-

* I have taken some trouble to ascertain what would be the relative cost of steel mains as compared with cast-iron ones. At any particular time the cost will, of course, vary according to the state of the market at that time. But, generally, it may be assumed that a steel main, about one-quarter the thickness of an iron one, will cost as much as the latter. Steel plates could be conveyed up country very much more easily than iron pipes, and there would be some saving in the item of transit, by employing the former; but I cannot recommend their use. It must be remembered that steel corrodes under the action of water much more rapidly than cast-iron, and that for the same money, there would be four times as much metal in pipes made of cast-iron, as there would be in those of steel. Under these circumstances, of course, cast-iron would last much longer. First cost, moreover, in cases of this kind, should not be considered as the only point. The expense of renewal and maintenance are important items, and, when these are calculated, the superiority of cast-iron declares itself forcibly. I should add that my statement regarding the more rapid corrosion of steel is not based on my general acquaintance with the use of this metal, but that it is the positive opinion of one of the largest steel manufacturing firms in England, who were consulted on the subject. Although it would have been manifestly to the advantage of this firm to have recommended the use of steel, they could not conscientiously do so. One fact of this kind is more convincing, than a volume of general arguments. If the use of steel were ever to be contemplated, it would be well to specify in the contract that all plates worn out or found defective within a certain period, say five or six years, must be made good at the contractor's expense. The insertion of a clause to this effect, would produce tenders which would, at once show what confidence was placed in the power of steel to resist the action of corrosion.

I should not omit to mention that as far as can be ascertained, no steel mains have yet been laid down in England. If there were, an advantage in the use of steel over cast-iron, we might surely expect to find it used where it is produced.

gested. Having already shown* the inadvisability of constructing dams of earth in the Concan, where no good clay is to be obtained, I will now show the inadvisability of bringing the water in metal pipes, or rather, as these must of necessity be employed to some extent, I will show the advantage of restricting their use as much as possible.

In the first place the size of iron mains, and consequently the quantity of water deliverable by a single line of pipes, is limited. I believe the largest main yet put down has not exceeded four, or at the utmost four and a half feet in diameter. The reason why we are confined to about this size is that, if we make them larger, the pipes become too heavy and unwieldy to be carried across country. But it is an advantage to have them as long as possible, because, the longer each pipe is, the fewer are the joints in the entire line, and the less is the cost of laying down. All the smaller sized pipes, therefore, are cast in twelve-foot lengths, and they are not found inconvenient either to carry or to fix. But when the size increases to three and four feet in diameter, and especially if the pipes are to be taken to a rough country, and laid along a line where there are no roads, it becomes necessary to cast them shorter, or in about nine-foot lengths. This reduces the individual weight of each, and makes it more manageable, but the effect is that in the entire line, four joints become necessary, where three only sufficed before. Every extra joint, moreover, is equivalent in weight and cost to one-foot length of the pipe. Although, therefore, each pipe is lighter and costs less, the whole line is heavier and costs more. Thus an advantage secured in one direction is partially counterbalanced by a disadvantage appearing in another. Besides, the joints being those points in the line where leaks are most likely to occur, and which have to be made with special care, every extra joint simply adds to the chances of the waste of water, as well as to the expense. These considerations, therefore, prove to me that we cannot, in order to make our large pipes lighter, shorten them to any great extent.

This being the case, the importance of the point with which I started, will now be appreciated. If we are limited in the size of our mains, we are practically limited in our supply of water. Some may reply that there is no engineering reason why two or a dozen mains should not be laid down; that, although it may be the case that we cannot have one

* *Vide Professional Papers, Second Series, No. LXVIII.*

main larger than a certain size, there is no reason why we should not have several of that size. This is true, but it must be remembered that the engineering objections to this are not the greatest ones. The cost of two or more mains would be so great, that no project could be floated with such a heavy weight. Thus, then, the limit to any project for the supply of Bombay with water, is the discharging capacity of a pipe about three and a half, or four feet in diameter, these being about the largest sized pipes ever made. Further on I will show what this amounts to.

Another and a very serious objection to the use of metal is, that it wears away so rapidly.* No really effectual means have yet been discovered to prevent the destruction of iron by corrosion, &c. How long a line of pipes may last in India no one could say, but, nevertheless, it is perfectly clear that every line laid down, must, like a line of railway, sooner or later be renewed. The repeated cost of these renewals, must, after some time, become enormous. It is the opinion of many that even the Vehar main which has not yet been laid down fifteen years, will before long require renewal. This is supported in a great measure by the state of those pipes which have occasionally, in consequence of leaks, been taken up. The amount of corrosion, both inside and outside, is quite beyond what most people would suppose.

I have already pointed out that Mr. Aitken anticipated the wearing away of the steel main proposed by him to be laid down from the Shewla reservoir to Bombay, and in answer to this objection, he replied that when the time came to renew the main, Bombay would be able to afford the cost of one of double the capacity. But any one can see that this is not the point. The point is whether, if the town can save the cost of renewal, it would not be foolish to incur it.

Another objection to iron pipes is, that, not being manufactured of sufficiently good quality in India, and being obtainable cheaper from England, it becomes necessary to keep a large stock in hand for contingencies. Their cost being, under even the most favorable circumstances, as I shall presently show, very great, a large capital must remain idle.

Then, again, to repair pipes, skilled European labor is required, and to keep up a staff of Europeans for the purpose, adds greatly to the cost of maintenance.

* "I have seen cast-iron pipes laid down in Bombay, which have been corroded away (from the outside) in about five or six years." *Vide* page 14, Mr. Aitken's *Report on the Extension of the Bombay Water Works*.

But above all these objections is the insuperable one of their first cost. Let me assume that a pipe of $3\frac{1}{2}$ feet diameter is to be laid down for Bombay. Such a pipe, in my opinion, should not be less than, say, $1\frac{1}{4}$ inch thick. Its weight would be about 15 cwt. 2 qrs. per yard, or 1,364 tons per mile, allowing a joint at every nine feet. The price of iron, including every expense, will be £16 a ton,* and the total cost of a mile of $3\frac{1}{2}$ foot main would be, say, £22,000.

I will now turn to the subject of masonry channels, and first as to their limits in size. It is quite clear that, so far as the engineering of the question is concerned, it is just as easy to build a conduit ten or twenty feet as it is to build one five feet wide or high. This being the case, and supposing masonry channels can be used, there is evidently no practical limit to the quantity of water which a *single* conduit, so different from a single iron pipe, may be made to convey. Thus one conduit would often suffice, where two or three pipes might be required.

In the second place, unlike pipes, the materials and labor for conduits need not be brought from England. They exist in the country—an advantage which it is hardly possible to magnify. The material is of the cheapest kind, and so is the labor. No large stock of the former need be kept at hand, nor need any expensive establishment of the latter be maintained. The nature of the work is both so simple, and so well understood by the common laborers of the country, that they alone are quite sufficient for all purposes.

Then, again, masonry does not soon wear away. If properly constructed, it is practically imperishable. Some of the Roman aqueducts are standing to this present day, and I believe there are masonry channels now in use in parts of Italy which were constructed in the days of the Cæsars.† Under these circumstances, it will be readily understood that the cost of renewal of conduits need not be an item in the expense of a project—at all events, not for the next twenty generations.

* This has been fixed by me in communication with one who is well conversant with the iron trade. I wish I could lower the rate and sacrifice some portion of the strength of my argument in this place, in order to reduce the estimates of the various projects I shall have further on to submit to the Bench. But Rs. 160 a ton is what I have calculated all the pipes in my projects at, and in spite of every desire to keep the estimates as low as possible. The price of pig-iron has risen about 100 per cent in the last twelve months. It is almost certain, moreover, that, in consequence of the rise in the price of wages, and of the reduction in the number of working hours which has taken place in England and Scotland, the price of iron will never fall again to what it was a year or two ago.

† I have personally examined the masonry in the largest of the aqueducts at Rome, and was surprised to find in what a wonderful state of preservation it was.

And now as to the cost of conduits. As iron pipes are limited in size, the best plan will be to compare, say, a three and a-half foot main with a conduit capable of discharging a certain quantity of water. Such a main, with a fall of five feet per mile, will discharge* 13,000,000 gallons daily. A conduit having a waterway four feet deep, and five feet wide, and being arched above, would with the same fall, discharge† nearly 40,000,000 gallons, or three times as much. The cost of such a conduit will vary according to the soil in which it is built. In the case of the projects which I shall recommend for Bombay, the conduits would be almost entirely tunnels through solid rock, and a tunnel six feet high in the middle, by five feet wide (about as small a one as could conveniently be constructed) at the rate which has been tendered for the Toolsee work under Mr. Walton, would cost £6,000 per mile. If the soil were of the very worst description, and building, beside tunnelling, had to be resorted to, the cost of the conduit would be, perhaps, twice as much, or £12,000 a mile. Considering that the hills through which the tunnelling would have to be carried, consist almost entirely of solid trap, and generally of the hardest description, I feel certain that a very small portion of the tunnel will have to be built. But let me even suppose that one mile out of every three has to be built, then the average cost would be Rs. 80,000, or £8,000, a mile. I will, however, take it at more than this, at as much as £9,000.‡

Thus, it turns out that a pipe, three and a half feet in diameter, will cost two and a half times as much as a conduit which discharges three times as much water. In other words, the cost of a conduit will, comparing the quantity of water delivered, be about one-seventh, that of a pipe.§

* According to the formula most generally in use—viz., Hawksley's— $G = \sqrt{\frac{(15 D)^5 H}{L}}$; where G is the discharge in gallons per hour, L the length of pipe in yards, H the head of water in feet, and D the diameter of pipe in inches.

† By the well-known formula, which is a modification of Bytelwein's, $v = 55 \sqrt{2 \lambda f}$, where v is the velocity in feet per minute, λ the hydraulic mean depth in feet, and f the fall in feet per mile.

‡ This rate, with contingencies are allowed for further on, is nearly £9000 a mile. The Glasgow aqueduct, the cross section of which has a superficial area twice as great as that of this channel, cost about £18,000 a mile. At this rate, therefore, the latter ought not to cost more than £9,000 a mile. Since the construction of the Glasgow aqueduct, and particularly within the last three years, the art of tunnelling has improved immensely, and I think we may now assume that the Bombay aqueduct would not exceed this sum. I am confident, from a close examination of the strata along the entire line, that a very small proportion of the channel would have to be built. The Glasgow aqueduct passed in many parts through water-bearing material, which of course must have given great trouble to work through, and must have effected the cost of the scheme materially. There is not the slightest chance of our having to tunnel through strata charged with water.

§ Only to give the reader an idea of the enormous cost of pipes as compared with the other items

In order to convince the reader that this is not exaggeration, we may make the comparison in another way, and the result will be about the same. I have already mentioned that a main $3\frac{1}{2}$ feet in diameter, will cost £22,000 per mile. Let us ascertain what the size of a conduit to cost this sum would be, and how much water it would give us. A six-foot square tunnel, with as flat an arch above as possible, would not cost much more than about £10,000 a mile under favorable circumstances, i. e., if the soil through which it was driven were rock, and no masonry were required. If the soil were bad, and the conduit required to be lined with masonry, such a tunnel would not exceed £20,000 per mile. Say that the average cost of the conduit through good and bad soil were £15,000 a mile. Then, as it would deliver 80,000,000 gallons daily, or six times as much water as the pipe, costing £22,000 a mile, the relative cost of the conduit would be about one-ninth that of the pipe.

And now let me direct attention to a point I have purposely reserved to the last, and which, I think, the reader will admit to be an unanswerable argument in favor of conduits as opposed to pipes.

If there were any advantage in pipes, this advantage would be ever so which go to form the estimate for a water-supply project, I take the following facts from *Mr. Aitken's Report on the Extension of the Bombay Water Works*. *Vide pages 29 to 32.*

POWAY PROJECT.

				£.
Cost of Reservoir,	12½	lakhs of rupees, or, 122,500
„ Land,	6	„ „ „ 60,000
„ Iron Pipes,	17½	„ „ „ 172,500
			<u>36½</u>	
Total,			355,000

Thus the pipes was to cost nearly as much as the reservoir and land put together.

KENNERY PROJECT.

Cost of Reservoir,	17	lakhs of rupees, or, 170,000
„ Land,	1	„ „ „ 10,000
„ Iron Pipes,	23½	„ „ „ 235,000
			<u>41½</u>	
Total,			415,000

In this case the pipes was to cost more than the reservoir and land together.

SHEWLA PROJECT.

Cost of Reservoir,	11	lakhs of rupees, or, 110,000
„ Land,	4½	„ „ „ 45,000
„ Steel Main,	124½	„ „ „ 1,247,500
			<u>140½</u>	
Total,			1,402,500

And in this case the cost of the pipe was to be more than eight times as much as the reservoir and land together!

These facts show the necessity which exists for every effort being made to reduce the cost of the means of bringing the water to the town from the reservoir.

All the estimates in this Article, illustrate the same subject—*vis.*, the great cost of iron pipes as compared with that of the other items.

much greater in a country where pipes could be manufactured cheaply and *vice versa*, the advantage would be less in a country where they were difficult and costly to obtain. Let us then inquire whether pipes have been used in preference to conduits in the land of iron. I suppose if any one were asked where pipes could be obtained cheapest, he would at once say Glasgow, where both iron and the coal to manufacture it with, are found in such abundance. But what do we find to be the case? In the Loch Katrine Works, among the first water-works in the world, out of a total length of 34 miles of pipes and conduits, from Loch Katrine to Glasgow, there are only 12 miles of pipes and 22 of conduits, and in a total length from Loch Katrine to the service reservoir of 25 $\frac{1}{2}$ miles, there are only 3 $\frac{1}{2}$ miles of pipes and 22 of conduits. Mr. Bateman, admittedly one of the first hydraulic engineers of the day, rather than lay down pipes, preferred to tunnel through hills, and some of the shafts were nearly 300 feet deep! Can any one after this doubt the necessity of *our* dispensing with the use of iron as much as possible? If Mr. Bateman found it cheaper to bring water through conduits to Glasgow, where iron could at the time be obtained at £4 and £5 the ton, and where every mechanical appliance, cheap fuel, and the best workmen could be obtained, how much more imperative must it be for us to adopt conduits in Bombay, where pipes will cost £16 per ton, where the use of mechanical appliances entails a heavy cost, where the price of coal 60s. per ton, and where skilled workmen are not only expensive, but difficult to obtain.

Let me give another example in which conduits have been used in place of pipes, and one out of England, and where the features of the country are very similar in their character to those of the Concan. The water from the great Furens Dam* is drawn for the supply of St. Etienne through a masonry conduit which has been built in open cuttings on the sides of the hills. In this instance it has actually been found cheaper to build a long masonry channel, than to lay down a direct iron pipe, and the channel—just as would be the case in the Bombay Water Works has been built of stone quarried from the excavations made to receive it. Open cutting has been resorted to for the St. Etienne Works in place of tunnelling, because the hills are not tortuous; but where they are so, and where, therefore, the length of the conduit would be out of all proportion to the direct distance of the reservoir from the town, there is no doubt that,

* *Vide* (1) note on page 76 of No. LXVIII., Professional Papers on Indian Engineering. Second Series.

as in the Glasgow Works, tunnelling would be by far the better method of the two.

Strong as this argument is, it becomes still stronger when we remember that the art of tunnelling has wonderfully improved since the Glasgow Water-Works were carried out. There is hardly any branch of engineering, in which such great strides have been made. This is shown by the last tunnel built under the Thames, which was successfully completed in a few months without the least difficulty, while Brunel's Tunnel took years to construct.

Where much water is found, and where the soil is sandy and treacherous, there are some difficulties to overcome; but in the case of the tunnels for the Bombay Water-Works, the strata everywhere are known to be trap, and generally of a hard compact nature. The tunnels, moreover, run from 200 to 300 feet above the water level of the country. I only hope water may be found, for it will render the work far more easy of accomplishment. The hills are so uncommonly dry, there is but little water to be found on them for even drinking purposes.*

Hitherto I have only treated of conduits in the common acceptation of the word, *i. e.*, as channels through which water flows as through a canal: I wish now to say a few words on conduits under pressure.

The island of Bombay and the surrounding country consist, of hardly anything but trap. In most parts, this rock is hard and compact, and, if it were free from fissures, there is no doubt it could be depended upon for the conveyance of water, even under very great pressure. Unfortunately, however, trap is a rock which varies perhaps more than any other in its nature, passing from the hardest basalt, to the softest volcanic tufa. The abundance, however, of basalt, and the fact of its being constantly found in the valleys, compelled me to consider whether it would not be worth while to obtain the opinion of a geologist, as to the likelihood of success, if rock syphons were attempted where the strata promised to be sound. The valuable opinion of Mr. Blandford, who is known to be one of the ablest geologists in India, was solicited, but I regret to say that it is not favorable to the idea of rock syphons. At the same time I am bound to add, that it is far from being so unfavorable as to prevent a trial being made.

* I and my surveyors have always had to carry our water for use from Camp. We have occasionally found water on the hills, but in very small quantities—either in pools or dribbling down the face of a rock.

It must be remembered that according to the quantity of water brought to Bombay, from one and a half, to more than two lakhs of rupees would be saved in *every mile* of rock syphon used in place of an iron pipe. What I would propose to the Bench is, not that they should make an experiment on a grand scale involving great expense; to arrive at an opinion on the subject, a small outlay is all that is required, and the experiment should be made without delay, and in the island of Bombay itself.

It does not matter what project is decided upon, or what the quantity of water to be brought to the town may be; the tunnel will answer equally well for any of the projects, and the smallest sized one that can conveniently be made will deliver five and six times more water than can be required. Let the experimental tunnel be only half a mile long, and let it be constructed along some portion of the line which the pipes will follow, if the tunnel does not answer. Let shafts be sunk at intervals of two or three hundred yards apart, and let the tunnel be driven *at the depth of fifty feet below the point at which solid rock is found*, not merely fifty feet below the surface of the ground.* Nearly everywhere in the island sound rock will be found, at less than 20 feet from the surface, so that the tunnel would not lie more than about seventy feet below. If, in sinking the shafts, the rock at this depth were soft, it would not be necessary to carry the experiment further. I would not stop the work in hard rock, even if there were fissures, as one of the very points to be decided is whether the fissures could not be effectually stopped up to prevent the escape of the water. My own impression is that such fissures as may be met with, will not extend to the surface, but be merely confined to the distance of a few yards from the tunnel, and that no water, therefore, would escape through them.

After the tunnel was constructed, it could be filled with water, and the mouths of the shafts stopped up, and hydraulic pressure applied. There would not be the slightest chance of the tunnel bursting. Such a casualty would be impossible. At the very worst, the water might escape to the surface, and this would soon be ascertained, and an opinion could be arrived at on the experiment.

The argument brought against such a proposition will of course be that a rock syphon has never yet been constructed. My reply to this is, that

* This experiment should not be made in the neighbourhood of Koorla, or across the causeway, because the strata are not favorable, and iron pipes would probably have to be used in these places.

I knew of no town situated as Bombay is, where a rock syphon could have been attempted with a chance of success. It would be a pity for the Bombay people to condemn the idea, simply for its novelty. I do not for one moment maintain that rock syphons can be constructed, but, considering the extraordinarily exceptional nature of the rock about Bombay, I am most emphatically of opinion that the Bench should sanction, say, Rs. 30,000, to ascertain whether it is possible for them to save a first expense of eight or ten lakhs of rupees, and an ultimate one of perhaps fifty.*

To sum up, then, the arguments of this Article, I trust the reader will see there is no doubt that masonry conduits are many times cheaper than iron pipes; that they are far better suited to the circumstances of Bombay, where the materials and labor for their construction are both cheap and abundant, and where pipes are costly; that a single line of conduits will out-last a dozen or more lines of pipes; and that in adopting conduits, we should not be carrying out works of an experimental nature, but should merely be following the example of one of the finest and most successful water-works in the United Kingdom.

And, with regard to rock syphons, which must not be confounded with conduits, I trust he will see that, whatever may be the opinions of different people on a work, the like of which has never yet been tried, still considering the enormous saving which the success of such a work would ensure, we should be justified in going to some slight expense to prove by direct experiments the feasibility of the proposition.

ON THE ADVANTAGES OF A SERVICE RESERVOIR, AND THE NECESSITY
FOR LAYING PIPES ABOVE GROUND.

Hitherto it has been proposed in every project to deliver the water to Bombay under direct pressure from the storage reservoir. As I am of opinion that this would not only entail needless expense, but cause many more interruptions in the regular supply to the town than would take place if we had a service reservoir nearer at hand, it is necessary that I should prove the point.

* Since writing the above, the price of iron has gone up still higher, and it appears to me more than ever necessary to make the experiment recommended above.

It does not of course follow that because channels are cheaper than pipes, therefore to bring the water nearer to Bombay by help of channels first, and then to deliver it by pipes, will be cheaper than to employ pipes only. It may so happen that the additional cost of the service reservoir in the former case may render that system on the whole more expensive. I will, however, show that, so far as Bombay is concerned, there is no doubt of the advantage of the method of distributing the water from a service reservoir. Let me take by way of illustration any of the projects which have been proposed. The Kennery Project will serve for the argument as well as any other.

In order to bring the Kennery water direct from the lake, Mr. Aitken proposed a main 32 inches in diameter, and $1\frac{1}{2}$ inch thick.* It was moreover to be 22 miles long, and to cost $23\frac{1}{2}$ lakhs of rupees, or rather more than a lakh a mile. Now I find that by means almost altogether of a conduit, the Kennery water can be brought to within $9\frac{1}{2}$ miles of Bombay, and that from this point the pipe, instead of being 32 inches in diameter, need not be more than 27. The unprofessional reader will naturally suppose that if the pipe is reduced in size, it will not deliver the same quantity of water, but this is not so. The pipe of 27 inches diameter will in the second case deliver quite as much water as the pipe of 32 inches will in the first. The apparent paradox is easily explained. A pipe delivers water in proportion to the head of water compared with its own length. A pressure of 500 feet is no more effective at the distance of 50 miles than the pressure of 100 feet at the distance of 10 miles. The discharges of all pipes are calculated on this principle. The discharge in the case of a pipe from the Kennery Lake would be in proportion to the head at that long distance. Let us suppose the water to be taken from the lake at a point 170 feet above Bombay, which is about the level at which it would have to be drawn. Then the average fall available for the pipe would be $\frac{170}{22 \text{ miles}}$, or not quite 8 feet per mile.

Now if, on the other hand, we first brought the water to within $9\frac{1}{2}$ miles of Bombay before delivering it to the town under pressure, I find this could be done with very little loss of head. The distance between the Kennery and the service reservoir is $8\frac{1}{2}$ miles, and, excepting in one portion of the line (three-quarters of a mile long) where, there being a depression in the hills, it would be too expensive to construct a masonry

* Vide page 30 of his *Report on the Extension of the Bombay Water Works*.

work, and a pipe would have to be laid, we could use conduits throughout. If we did so, we should not have to give the channel a greater slope than 12 inches a mile, because, even with a waterway 5 feet wide and 4 feet deep, it would discharge more than twice the daily supply from Kennery. The total fall, therefore, in the $7\frac{1}{2}$ miles would be $7\frac{1}{2}$ feet.

The syphon across the depression in the hills need not have a greater slope than 5 feet per mile, as, if it were even 36 inches in diameter, it would carry the daily supply from Kennery; but in calculating the cost I will suppose a 42 inch* pipe is used, or one capable of discharging one and a-half times the daily supply. The total fall, then, in the syphon, three-quarters of a mile long, would be $3\frac{3}{4}$ feet, and the total fall in the conduit and syphon together would be just $11\frac{1}{4}$ feet,† so that if the water, as I propose, left the Kennery Lake 170 feet above Bombay, it would reach the service reservoir at $(170 - 11\frac{1}{4})$ 158 $\frac{3}{4}$ feet above Bombay. This pressure being available at the distance of only $9\frac{1}{4}$ miles, the average fall would be $(\frac{158\frac{3}{4}}{9\frac{1}{4}})$ or about $16\frac{2}{3}$ feet per mile, more than double that in the case of one long continuous pipe from Kennery. This great fall enables us to reduce the size of the pipe, so that, whereas a pipe of 32 inches diameter is required in the one case, a pipe of 28 inches diameter suffices in the other. Nor is this all; the smaller the pipe the thinner the metal to resist the pressure may be, so that besides a smaller pipe we need not have one so thick.

The cost of the $32\frac{1}{2}$ -inch main from Kennery was calculated at $23\frac{1}{2}$ lakhs of rupees. The cost of the channel syphon and pipe would be:—

	RS.
$7\frac{1}{2}$ miles of channel, at Rs. 80,000 a mile,	6,00,000
Syphon $\frac{3}{4}$ -mile long, 42 inches in diameter and 1 inch thick,‡ weighing 832 tons, at 110 Rs. a ton,	91,520
$9\frac{1}{4}$ miles of 28-inch pipe, 1 inch thick, weighing 720 tons per mile, at 110 Rs. a ton,§ or 79,200 Rs. a mile,	7,52,400
	14,43,920
Add 10 per cent. for contingencies, say,	1,44,080
Total,	15,88,000

* In my Kennery Project the pipe I propose is 48 inches in diameter, but this is for special reasons, which do not concern my argument here.

† In my Kennery Project the actual fall is $14\frac{1}{4}$ feet, but this also is proposed for special reasons, are too long for me to explain now. For the purposes of my argument, the above statement is correct, inasmuch as we are concerned here, not with the fall it would be best to give to the channel syphon—for that may depend on several other considerations—but the fall we could give to them in order to keep the water as high as possible.

‡ It might be only three-quarters of an inch thick, as it would not have to resist a greater pressure than a head of water of 50 feet.

§ About the same rate at which the $32\frac{1}{2}$ inch main was calculated.

So that the difference of cost between a long pipe from the lake and a conduit, syphon, and pipe, amounts in this one project to about eight lakhs of rupees. Now the cost of a service reservoir will not be more than three lakhs, so that the advantage of a system with a service reservoir, so far as mere expense is concerned, is manifest. The argument would be still stronger if I took a project with a reservoir beyond Salsette—such, for instance, as the Shewla or the Tansa Project.

The other great advantage which a service reservoir possesses is this: we reduce the number of interruptions to the regular supply. If we have a long pipe—as, let us suppose, for instance, the one from Kennery—an accident in any portion of the line of 22 miles must necessarily cause the entire supply to the town to be cut off while the damage done is being repaired. But in the case of a service reservoir, if an accident happens above the reservoir, the supply can still go on from the latter while the conduit is being restored, and, when the conduit is open again for use, the service reservoir can be refilled.

The great length, fifty-six miles, of the continuous pipe from the Shewla reservoir to Bombay, proposed by Mr. Aitken, constituted in the eyes of most of the profession one of the greatest objections to the scheme. The longer the pipe the greater must be the number of bursts which take place in it, and the greater must be the number of stoppages to the supply to the town. So that, if the pipe from Vehar to Bombay, fourteen miles long, bursts a dozen times yearly, and the water has to be shut off from the town for twelve days in the year, it would have to be shut off four times as often, or for forty eight days in the year, in a pipe four times as long,—viz., fifty-six miles; and this, where the interests and welfare of nearly three-quarters of a million people are concerned, is an important consideration.

Even if a service reservoir entailed considerable extra cost over a continuous pipe—which it fortunately, in the case of Bombay, does not—I should still most strongly advocate its adoption, in consequence of the great advantage it affords in the regularity of the supply not being dependent on the security of a single long line of pipes.

Here again, in recommending the use of service reservoirs situated nearer to the town than the storage reservoirs, I am merely following the practice of the most eminent hydraulic engineers of the day. Both at Manchester and Glasgow, and also at numerous other towns, the water

is stored for use at a long distance from the town, but is distributed to the population from service reservoirs kept constantly filled from the distant lakes. Indeed, the time will come, if it has not already, when the inconvenience of the stoppage of the water from Bombay for even a few hours will be considered so intolerable, that it will be necessary to have one or two distributing reservoirs in the town itself to contain a sufficient supply for one or two days. I do not recommend their construction just now, because I think the town had better spend all its present available means in storing water and in bringing more to the people. Distributing reservoirs can be built at any future time when the want of them is really felt.

In conclusion, I have only to add that it is surprising to me to find that the necessity of bringing the water as near as possible to Bombay before distributing it under pressure should never before this have been pointed out to the Bench, and that I should have to bring it to their notice. The mere fact of the system being exactly in accordance with the best European practice should have drawn attention to the subject long ago.

I have already referred to the rapid destruction of iron by corrosion, and Mr. Aitken has stated in his *Report on the Extension of the Bombay Water Works*, that he has seen cast-iron pipes laid down in the island corroded in five or six years. There is no doubt whatever that the process of corrosion is much more rapid in Bombay than it is in England, and that this is, in great part, due to the large quantities of saline matter mixed with the soil. So important did Mr. Aitken think the subject, that he considered it necessary to advocate that his pipe should be placed on standards above ground. The great objection urged against this proposition, during the sitting of the Water-supply and Drainage Commission in 1869, was that the water would arrive in Bombay at a temperature sufficiently high to boil an egg. Now, on this one point I agree with Mr. Aitken, and I altogether dispute the validity of the objection. I am of opinion that the temperature of the water in a pipe exposed to the sun would not be materially affected; but the fact can be ascertained by the simplest of experiments, and at a most trifling expense, perhaps 50 Rupees.

I propose that one of the 30-inch pipes in the possession of the Bench be taken and, being supported on standards, be exposed to the full heat of the sun some day in October, when the sun is, perhaps, as powerful as

at any time of the year. Let the two ends of the pipe be closed with flat iron plates, the pipe filled with water, and arrangements be made for drawing off the water from time to time by a small cock. Beginning at six o'clock in the morning let small quantities of the water be drawn at every hour up to six in the evening, and each time let a thermometer be plunged into the water to ascertain its temperature. We shall then know, to a certainty, to what extent exactly the water will be heated in a pipe exposed all day long to the action of the sun.

Let it be borne in mind that the water delivered in Bombay through a main would never be so warm as that in the experimental pipe suggested by me. In this latter case, the pipe will be exposed to the sun's rays all day long, and the water will be heating all this time; but the water in a main would not take more than five or six hours to reach the town after it left the reservoir.

If the experiment shows that the temperature of the water is not sensibly increased, the pipes can be laid above ground without any protection from the sun, but, if the temperature rises, it will be necessary to consider if steps could not be taken to protect them in some way, so that the direct rays of the sun should not fall on them. I am opinion that there are many ways in which this could be done, but I will merely suggest one or two, not advocating any particularly, but merely putting them forward for consideration with the numerous other plans which are sure to be proposed in Bombay. Bundles of dried grass, one of the few things to be had very cheap in Bombay, might be laid four inches in diameter over the upper half of the pipe, and a sheet of thin galvanized iron, bent to a semicircular form, be laid over the grass. At intervals of three or four feet apart, hoop iron might be passed round the whole, binding them together, and a coat of tar might be put over the upper half of the pipe for its better preservation.

Or a sheet of galvanized iron might be fixed over the pipe without any hay between, but in this case it would be well to have a space of about eight inches between the sheet and the pipe, so as to let the air play freely between them.

Tarred felt might also be tried, but I do not recommend it, as I fear it would not last long. But it does not matter what method is adopted. Some good plan is sure to be discovered finally. What is really necessary at first is, that the Bench should be satisfied that pipes laid above

ground will last longer than if buried in the earth, and in order to prove this point, I only ask them to examine the line of pipes between Vehar and Bombay. Soon after leaving the Main Dam, the pipe runs over the Gopur stream, and is exposed to the air for a length of about a hundred feet.* This portion of the line appears now to be in nearly as good a state of preservation as on the day when it was laid down. But let any other part of the line which has been buried beneath the soil be exposed, examined, and compared with this portion. The pipes will be found with their surfaces rough, eaten through, or scaling off with corrosion. Facts of this kind are worth a thousand opinions, and if it be the case, as it undoubtedly is that pipes exposed to the air do not corrode to anything like the same extent as those which are buried, there surely can be no doubt, considering the enormous price of iron now, of the advisability of our taking every step in our power to make our mains last as long as possible.

The mere saving in the water-supply alone should ensure the consideration of the subject. When pipes are buried, they may go on leaking for years without the fact being discovered, whereas, when they are laid above ground, the slightest leak betrays itself at once, and can be stopped without delay.

I trust I have now demonstrated that, before we go on blindly repeating what may prove to be the errors committed before, it is incumbent on us first to ascertain whether pipes above ground in Bombay do really last longer than those buried beneath the soil, and, if this is proved, whether the temperature of the water will be sensibly affected by exposing the pipes to the full heat of the sun, and, even if this be the case, to inquire whether steps cannot be taken to protect them from absorbing such an amount of heat as would raise the temperature of the water.

H. T.

* I write from memory.

No. LXXVII.

HISTORY OF THE WATER-SUPPLY OF BOMBAY.

[*Vide* Plates XIII. to XXX.]

BY MAJOR HECTOR TULLOCH, R.E.

ON the 2nd June, 1845, the Government of Bombay were so alarmed at the deficiency of water in the town, that they passed a Resolution appointing a Committee to report with the least possible delay on the state of the wells in the Island, the quality of the water in them, and the quantity remaining for consumption.

The demand for the Report must indeed have been very urgent, for the Committee, composed of Doctors Graham and Leith, submitted their views to Government on the very next day. They acknowledged the great want of water prevailing in the town, and the great distress felt by the people from the deficiency; they pointed out, moreover, that the water was, as a rule, bad in quality, in some instances brackish, and in others, tainted by the drainage from the streets. It will interest the reader to learn that the recommendations they made were: that the use of some private wells in Girgaum should be secured for the public by compensating the owners; that the wells on the esplanade where cattle were watered should be reserved for man; and that other wells in the same locality which had been closed, should be re-opened. One cannot but be struck by what must seem to us the mildness of the remedy proposed to be applied in those days in so serious a case.

The crisis must have been a very alarming one, for we find that, three days after the report was sent in by the Committee, the Government passed another Resolution, in which the Chief Engineer of the time was also called upon to report on the subject, and they expressed themselves "most anxious to prevent the recurrence, even during one year, of such a calamity as is now felt."

So great was the attention which the matter attracted, that before even the Chief Engineer, who took ten days only to think over his project, could reply to the demand of the Government, another gentleman, who had been devoting himself to the solution of the problem, stepped in and proposed a remedy for the evil. We find that on the 14th of June, a memorandum was prepared by L. C. C. Rivett, Esq., of the Civil Service, "On the practicability of obtaining a supply of Good Water for the Native Town of Bombay."

Mr. Rivett pointed out that it was hopeless to attempt to add to the supply by means of wells; that in order to keep the tanks in the town full up to a certain level during the whole year, the only plan was to collect rain-water during the monsoon, and that the principal desiderata were "an elevated position for a reservoir," "a large surface from which to fill this reservoir," and "facility of conveying the water from this reservoir to the tanks in question." Mr. Rivett wrote: "the principal points which at first sight present themselves for such an object appear to be"—I think the Bombay public will smile—"Nowrojee Hill at the back of the Gaol, the hill above Mazagon, the Chinchpoogly Hills, the hill above Parell, Malabar Hill adjacent to the Parsee Cemetery, and the hill above Col. Dunsterville's House." How wonderfully the town has grown since then, and how our wants have increased, we can realize by the fact that the idea should at one time have been even entertained that these sources might suffice.

A glimpse of the future Bombay must have been caught by Mr. Rivett even a quarter of a century ago, for, on consideration, he rejected all these sources. Calculating the areas of the important tanks on which the town depended for its supply, Mr. Rivett found they amounted to 672,000 square feet, and he considered it would be necessary to supply each tank with water to the depth of sixteen feet. Proceeding then on the supposition that the rain-fall was $6\frac{1}{2}$ feet in the year, and that only half of it could be collected, and assuming that the reservoir should hold

three years' supply, he found he should require a gathering ground of 240 acres. This would enable him to collect 200,000,000 gallons. As none of the sites above-mentioned offered this extent of collecting area, he proposed that a reservoir should be built on a hill standing on the peninsula called "The Neat's Tongue," but which we know better as "Trombay." He said—

"There is, however, on the peninsula called the Neat's Tongue, a hill which offers all the requisite advantages, and where a reservoir sufficient to supply fifty times the amount above specified (200,000,000 gallons), might be constructed. This hill is certainly 800 or 1,000 feet high; its sides are steep, and there are several spots on it in which the ground converging towards the nullahs, forms almost a natural crater, admirably adapted for a reservoir. There is here sufficient unemployd surface to collect water for a reservoir of almost boundless extent, and one, the bottom of which would be at least 300 feet above the level of the tanks it would have to supply. On this hill a point might be selected, distant from Sewree in a direct line three miles. The water from the reservoir might be conveyed from the hill by an aqueduct of iron pipes, supported on pillars of masonry, across the arm of the sea (dry at low water) which separates Sewree from the Neat's Tongue. From Sewree a similar aqueduct would lead the water to the Byculia Tank, in the first instance, and from thence it should be conveyed by underground pipes to the other tanks, or any other point in the native town, which in this manner might be as well supplied with water as London."

The Estimate of the cost of the works was as follows:—

	£.
5½ miles of 12-inch pipes from the Reservoir on Neat's Tongue to Bombay,	8,800
3 miles of pipes to distribute the water from tank to tank, ..	3,200
Masonry columns to support the 5½ miles of pipes,	16,940
Reservoir, about,	40,000
Total, ..	68,940

Or somewhat less than seven lakhs of rupees.

At this distance of time it is amusing to think, that the hill on the Island of Trombay, should ever have been considered so extensive, as to be able to give us a reservoir "of almost boundless extent." Since Mr. Rivett's day, the inhabitants have multiplied to such an extent, that the

supply from any reservoir in Trombay would hardly suffice the town for more than a week.

Mr. Rivett's proposition, although it was put forward with great ability, and was really, in my opinion, well worthy of consideration at that time, does not seem to have met with approval. At all events no action was taken upon it, and we may, therefore, conclude it died a natural death. Two days after the issue of his memorandum, the Chief Engineer, Lieut.-Col. George Jervis, came forward and submitted his remedy to alleviate the thirst of the patient. This was:—

“To provide three reservoirs in the following situations which afford sandstone strata which are saturated with water throughout the year—*1st*, The Dhobee's Tank on the Esplanade; *2nd*, Some eligible spot to be purchased in the Girgaum Oarts; *3rd*, The Coconut Oarts of Mahim. The first for the supply of the Fort; the second for the supply of the Native Town, from the verge of the Esplanade to a line running east and west from the Mombadavee Tank; the third for the supply of Parell, Byculla, Mazagon, and the Native Town, north of the line above-mentioned.

The supply of water in the reservoirs to be obtained by galleries, cut as far as possible in the sand-stone stratum. The water to be pumped from the reservoirs by steam-engines and conveyed through iron pipes to the different quarters. The reservoirs to be covered over by the engine rooms, and other buildings, to prevent evaporation, and to preserve the water pure.”

The patient, however, who was complaining not of having too much but too little water in his system, declared his symptoms were not dropsical, and accordingly refused to undergo the operation of tapping on such a large scale, so that the scheme, in spite of its ingenuity, fell to the ground.

On account of this obstinacy on the patient's part, the Government got into a more nervous and fidgetty state than ever, and, having apparently determined that the whole responsibility should not rest with them, they passed a Resolution on the 24th September, 1845, directing the attention of the Court of Petty Sessions to the subject, and requesting them to consider the “measures to be taken for husbanding the supply of water, and for keeping it pure and wholesome.”

The nostrum of the Court of Petty Sessions was an exceedingly mild one. They recommended that, in order to prevent waste, the tanks in

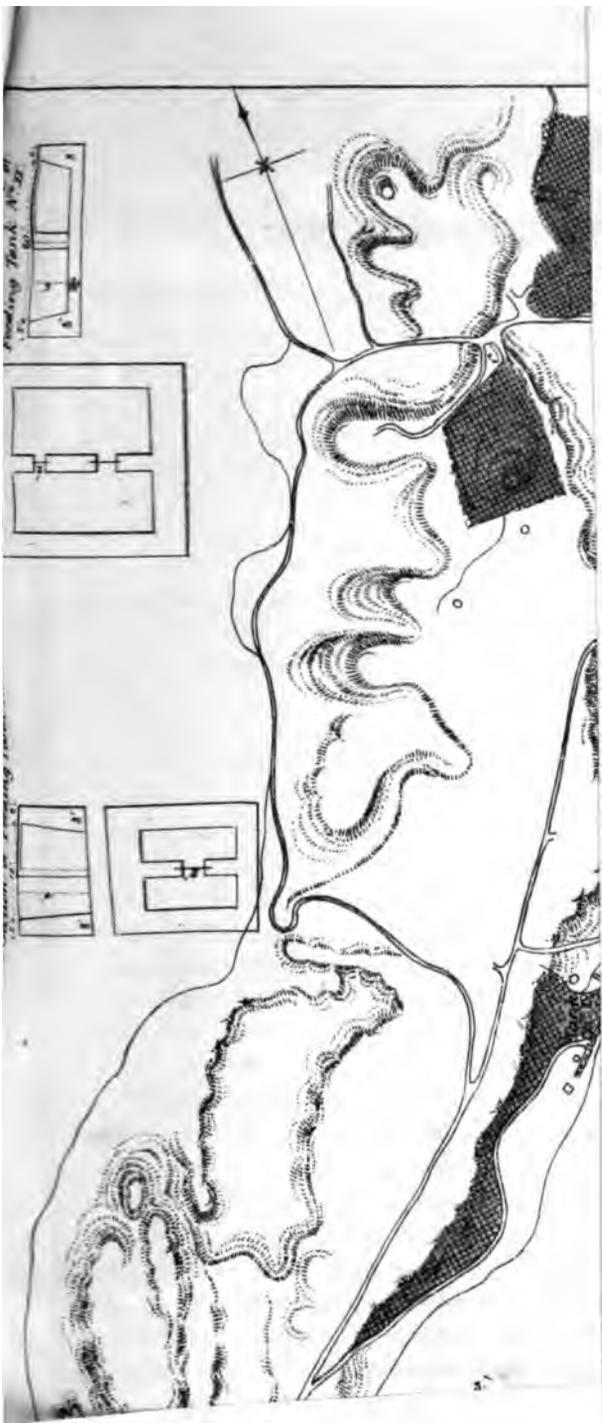



the town should be guarded by peons ; that a solitary spring, which there was at the Cooperage, should be ' reported ' on ; that the shipping should be made to water at Elephanta or Salsette ; and, of all things in the world, that the Government should issue a Proclamation, which was practically to the effect, that the people should not drink more water than was good for them, and that they were not to spill more in the act of drinking, than they could possibly help. The people were to be allowed to carry away as much as they chose, but, having got it into their houses, they were to take great care of it. The Government of those days must have had wonderful faith in human nature, if they supposed that a man, having taken the trouble to convey a certain quantity of water to his house, would be influenced in his use of it away from the surveillance of the outer world, and by a Proclamation !

However, this advice to the patient not to drink more than was good for him, while all the time he was dying of thirst, was of no use. In spite of the Proclamation, he still cried out for water, and the authorities seem to have considered the cry not an unreasonable one, for, on the 21st March, 1846, the Civil Architect of the Presidency, Capt. T. M. B. Turner, of the Engineers, acting under the instructions of the Chief Engineer, submitted a new project. This was to intercept the rain falling—1st, on a portion of that side of Malabar Hill which faces Back Bay ; 2nd, on the hill near that on which the Parsee Tower of Silence stands ; and 3rd, on some ground lying directly north of the Gwalia Tank, *vide Plate XIII*. Having intercepted the rain, Capt. Turner proposed to lead it into a reservoir 400 feet square to be built close to the Gwalia Tank. The total supply calculated to be obtained from this project, which was probably intended for only a portion of the town, was 29,000,000 gallons, or, as Capt. Turner put it, sufficient at the rate of five gallons a day for 62,222 people during 90 days.

But this proved of no use. The attraction of five gallons per head per diem was not enough to reconcile the patient to a sudden death after three months. In fact, the prospect of a short life, and a merry one did not suit him at all, for he cried out louder than ever, and so the crisis continued.

There now steps on the scene a man who took a very different view of the state of things, and who not only understood the alarming nature of the patient's case, but made a proposition which ultimately grew into the present water-supply of Bombay.

Captain (afterwards) Colonel J. H. G. Crawford, of the Engineers, leaving the wells and tanks in the town to take care of themselves, proceeded out of the Island, and, following the course of the stream which formerly took its rise near the village of Vehar, proposed to intercept it at a point not far from Koorla. Here the water was to be pumped up, and brought under pressure into Bombay by iron pipes. The dam was not to be built to retain any large quantity of water, but merely to give sufficient depth to pump from. This supply every year could of course last so long only as the stream continued to flow, or from the setting in of the monsoon, up to about December. For the supply of the town during the other months, a series of reservoirs were to be formed along the course of the stream above the dam, and, as the stream dried up, the water in these reservoirs was to be led down to the lowest one, where the pumps were to be placed.

An alternative scheme suggested by him, was to drain the Koorla valley by a system of underground channels to the point where the water was to be pumped up. He said:—

“Suppose a valley, as in the accompanying rough sketch; the nature of the soil being what I imagine it, I should sink a shaft (A) at the lowest point whence I wish to draw my water—in the present instance it would probably be 15 or 20 feet deep. I should run an open drain (AB)

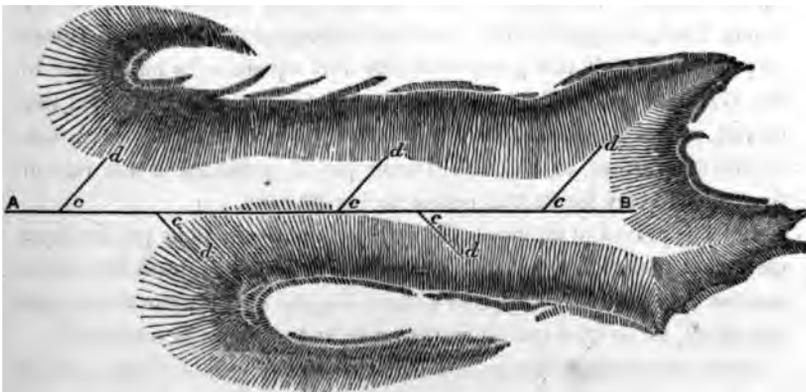

2½ wide, and as deep as circumstances would admit of, with a slight slope downwards towards A, building up the sides if necessary, and covering

the surface with flagstones and earth; and at certain distances, I would in like manner open the shorter cross drains (*cd*). In this way, looking at the bed of the valley as a vast sponge, the whole would be thoroughly drained without any loss from evaporation."

Captain Crawford's suggestions evidently attracted considerable attention, for the Board of Conservancy, to whom his letter was submitted, on the 16th May, 1846, called at once for further information on the subject. Accordingly, we find, three months after this another report, going into the subject in greater detail, was prepared. He had in the meantime been able to make a rough survey of the country, and to take a few levels, so that he now had some specific facts to work upon. He wrote:—

"The sketch, *vide* Plate XIV., exhibits the mouth, and a small portion of the course of the nullah, which takes its rise in the range of hills near the village of Vehar, in Salsette, and empties itself into the sea at the village of Koorla. The portion here represented flows through a nearly level country, partly waste ground, covered with trees and low jungle, and partly of rice cultivation. The bed of the nullah consists of rock and shingle, whilst the banks—which are 8, 10 and 12 feet high—are in places nearly perpendicular, and consist principally of earth. Across the mouth of the nullah, and just above high-water mark (BC), there is a natural bund of rock, which extends into the country on both sides of the nullah, and a little higher up, there is another of the same description. The hill D is 70 feet above high water-mark; it is almost a solid rock, and conveniently situated for any works requisite for establishing a head of water.

* * * * *

"The nullah continues to flow until the end of December. By erecting an engine at a favorable point for pumping, and laying a main of pipes to Bombay, there is no doubt that a considerable body of fresh water might be led into the town, and, taking advantage of the favorable natural formation, at the mouth of the nullah, and throwing a bund across at that point, the top of which might be at least 20 feet above the point A, the supply of water would be much increased at a comparatively small cost.

* * * * *

"I shall, however, proceed to show what would be (as near as I can at present ascertain) the first cost of the necessary works. These would consist of a bund at BC; providing a suitable engine and engine-house;

building up the sides of the reservoir on the top of D for procuring a head of water ; and laying down a main of pipes from Koorla to Bombay.

“ The hill D is 70 to 86 feet above the point A, or high water-mark ; on the top of this hill an extra 10 feet might easily be obtained in building a reservoir without any very extra heavy cost, thus giving a total of 80 feet. I suppose, on the average, that the water is to be delivered at a height of 20 feet above high-water mark in Bombay, which would, I think, be more than sufficient to reach all the public tanks. This will leave a height of 60 feet for a head of water upon which to calculate the discharge. I assume the length of pipe to be laid down at about 10 miles, its diameter 14 inches. These conditions, with a head of water of 60 feet, would give a discharge of 6,992,542 cubic feet, or 43,575 gallons per hour, without making deductions for angles in laying down the pipe, which need be neither great nor sudden.

“ For raising this body of water to a height of 80 feet, an engine of 176 horse-power would be required.”

The following is an abstract of the Estimate : —

	£.
13 miles of 14-inch pipe,	36,023
Engine, cost of erecting ditto, Engine House and Residence for Engineer,	13,900
Dam (at BC in sketch),	1,700
Reservoir (at D),	440
Total,	<u>52,063</u>

Or over five lakhs of rupees.

The alarming symptoms which the patient exhibited in 1845 and 1846, must have temporarily subsided, for nothing of importance seems to have been done in 1847. In 1848, however, the symptoms revived, and we accordingly find the public mind again in a ferment. In the month of May, the Chief Engineer, Lieut.-Colonel George Jervis, resuscitated his scheme of tapping the water-bearing strata in the island, but, before carrying it out on a large scale, he proposed :—

“ That Government be solicited to sanction the construction, in some convenient site on the northern boundary of the Esplanade, of a circular cut-stone well or reservoir, with one or two tunnels cut into the sandstone formation of the Esplanade as feeders to the reservoir, 100 yards in length, 6 feet broad, and 15 feet deep, or more if practicable ; the tunnels to be filled to within 6 feet of the surface with loose rubble stone, with a covering of rough stone slabs, levelled to the surface, with the soil excavated.”

18

bu
he

th
re
I
of
m
h
cl
it
fo
p
w

1

(

n
h
a
h
d
i
d
e
f
t
i
i



This idea did not take root in the public mind, for nothing came of the proposition, although, as we shall subsequently find, it was again taken up, and worked out by another Engineer. On the other hand, we find Capt. Crawford's project rapidly assuming a definite shape. He was too able a man not to see the great flaw in his previous schemes, and he was not long in rectifying it. Accordingly, in his next report, submitted in August 1850, instead of advocating the raising of the water near Koorla by mechanical contrivances to the height of 80 feet, he considered it would be better, in order to avoid the cost of pumping, to go higher up the stream, and to build his dam at a point 80 feet above the level of the bund he first proposed.* If after a time the supply did not prove sufficient, he recommended that the construction of a series of bunds still higher up the stream should be undertaken, and, if even this failed to meet the demands of the town, then that the water in the lower part of the valley should be utilized by the help of pumps.

And now we find associated with the originator of the present water-supply of Bombay, another able man to whom Captain Crawford entrusted the working out of his ideas. So satisfactory indeed was the manner in Lieut. (now General) De Lisle prepared the scheme, that not only did Colonel Crawford speak of him in high terms, but, finding his own original idea open to objection, he at once and finally abandoned the plan of pumping the water at Koorla.

It is in Lieut. De Lisle's Report, submitted so far back as March 1851, that we first meet the proposition distinctly put forward, to construct a reservoir at Vehar. The accompanying plans, *vide Plates XV., and XVI.*, which are copies of portions of two of those submitted with his Report, cannot fail to convince the reader that the present works are merely the embodiment of Captain Crawford's ideas. Here we have the lake not covering exactly the area occupied by the present one, but covering the greater portion of it. Here we have the dam not precisely in the position of the present main dam, but close to it. And here we have the line of iron pipes, connecting the lake with the town.

Lieut. De Lisle's reservoir with a dam about 50 feet high, was to impound in round numbers 1,000,000,000 gallons, and he proposed, in the event of this supply not proving sufficient, to raise the dam ten feet higher, and thus to obtain double the above quantity. He assumed a yearly rain-fall

* The reader will observe that we are rapidly advancing to the Vehar lake.

of 76 inches, of which 16 inches would be lost by evaporation, absorption, &c., and of which the remaining 60 inches would be available over an extent of gathering ground of seven square miles. On these data the quantity of water flowing into, and falling on the lake, would amount to 6,000,000,000 gallons, or six times the quantity required to be impounded by the 50-foot dam. The water was to be brought into the town under pressure by a cast-iron pipe 24 inches in diameter, and $14\frac{1}{2}$ miles long. The cost of the works was calculated thus :

	£
Pipes,	102,080
Dam, Waste Weir, Delivery Reservoir, and Conduits, ...	15,000
Contingencies, &c.,	2,920
	120,000
Total, ...	

Or twelve lakhs of rupees.

In a Resolution passed on the 26th April, 1851, the Government thanked Captain Crawford and Lieut. De Lisle in handsome terms for their labors, but called for more information on certain points.

We now take a further step. Another man comes on the scene, who appears to have succeeded Captain Crawford in the anomalous appointment of Superintendent of *Repairs*, the duties of which in some extraordinary way, seem to have been the investigation of *original projects*. Lieut. De Lisle's papers were forwarded to Mr. Henry Conybeare for report, who, in December 1852, submitted a carefully prepared memorandum on the subject. Although admitting that Lieut. De Lisle's surveys had demonstrated the practicability of ponding up in the Vehar valley a body of water apparently sufficient for the supply of Bombay, at the rate of 20 gallons per head per diem, he was of opinion that, owing to the preliminary nature of these surveys, no sufficient data existed for determining the cost at which the supply could be made available to the town. He recommended that accurate surveys should be made, but at the same time he put forth a scheme of his own, which the reader will recognise as similar in its main idea to that suggested years before by Colonel Jervis.

Mr. Conybeare was of opinion that, water obtained from surface collection being unfit for drinking until filtered, the springs in the littoral concrete formation in the Island should be made available to the town. He proposed that wells should be built in the water-bearing strata, and, that these wells should be connected by iron pipes with large reservoirs

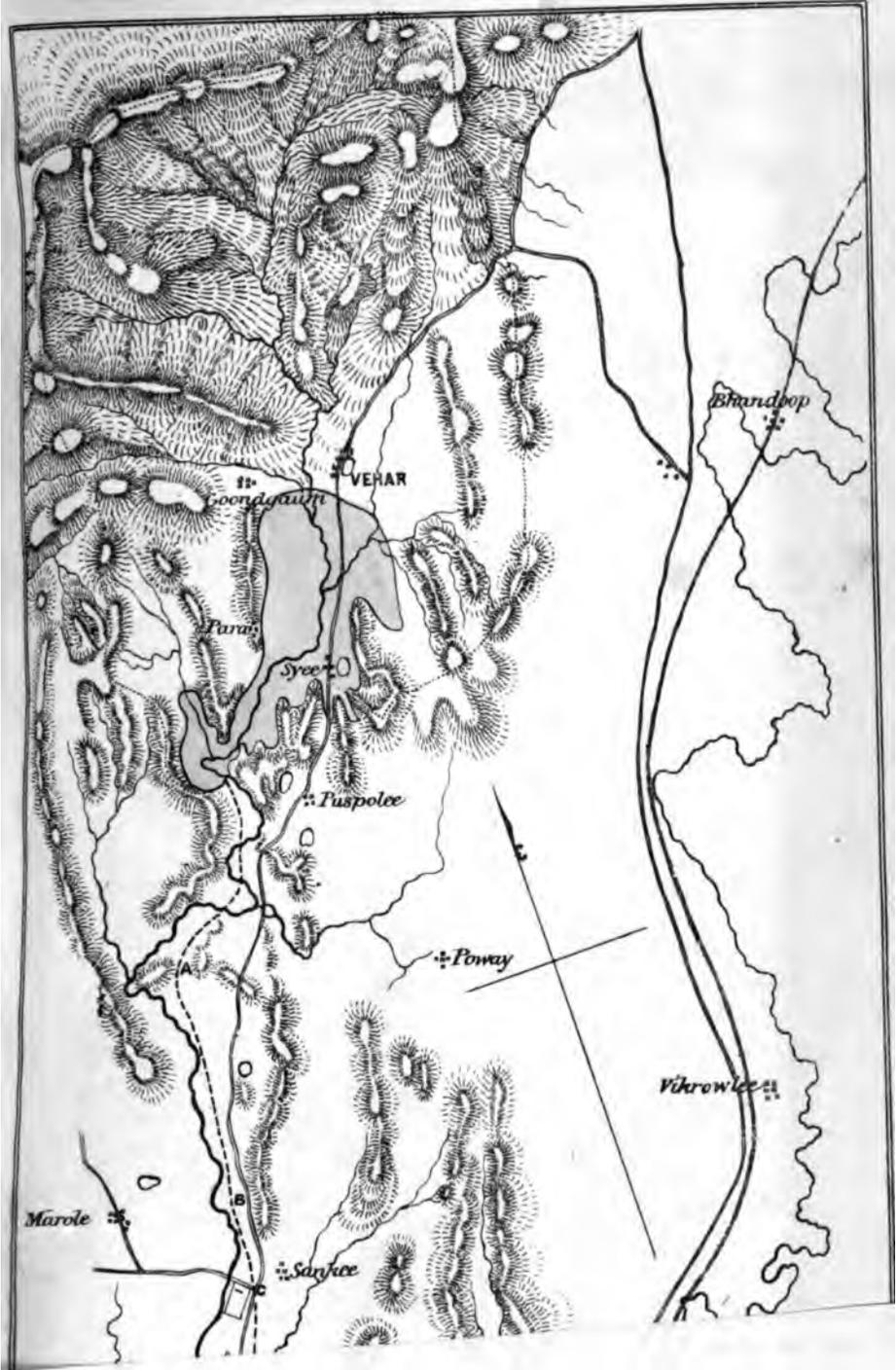





to be made in the solid trap underlying the superficial deposits. He thought that these reservoirs would be kept filled with water running in a constant stream from the wells. The iron pipes were to act as syphons. All that would be required would be to start the syphons by first closing the two ends, then filling the pipes with water, and then opening the ends again. The accompanying sketch, *vide Plate XVII.*, which is copied from some of the plans submitted with his Report, will illustrate the project. Mr. Conybeare proposed, moreover, that many of the tanks and reservoirs, should be roofed over, and that they should be supplied with water from filtering wells. The sides of these wells were to be "double walls two feet thick, and four feet apart, built of a porous sand stone, and enclosing between them a thickness of four feet of fine sand, the whole forming a filter eight feet thick." Besides the supply to be obtained from the littoral concrete in the Island of Bombay, Mr. Conybeare also suggested that the spring-bearing strata in Salsette, should be thoroughly examined before recourse was had to surface collection.

Fortunately this old idea was not carried out. The Board of Conservancy, in forwarding Mr. Conybeare's Report to Government, took an altogether different view of the subject. They expressed doubts as to whether a sufficient quantity of water could be obtained in the Island in the manner proposed by him, and they added that even if it could be so obtained, it would require to be sent into the town at great expense and from many sources. They were of opinion also that none of the water in the public tanks excepting only one "could be considered wholesome—that they were all more or less filled by drainage, at the best of times impure, and subject to the taint of a large town." They pointed out, moreover, that late in the season, the quantity of water in many wells was not a quarter of what it was at the beginning, and that Mr. Conybeare had made a mistake in supposing that so many wells were available to the public, the fact being that a great number of those which he had mentioned for use were private property. Regarding the proposition that the spring-bearing capabilities of Salsette should be investigated, the Board said that, "any water which might be derived from springs would be found to be, if not below high-water mark, at so low a level, that the water would require to be forced up by machinery." They were "of opinion that a great additional supply of water was required for the health and comfort of the inhabitants, and that such supply could be best

obtained
tain Crav

The level
1854, the
water from
investigation
and in Mr
report on
was at low

Mr. Conybe
the main
Lisle, and
dam station
valley had
the rain-fall
miles only
inches at
as 124 inches
be collected

Small Reservoir
Large

* Mr. Conybe
what he calls
All the levels
form of the F
Foydones Data
Mr. Conybes
that it is 3-11
Datum is 171-6
within one. I
this, so far from
below mean sea
level, then Foydones
It has cost
these contradictions
investigate the
the profession,
to consult the



RAM of arrangement by which the water referred to distant and waterless localities

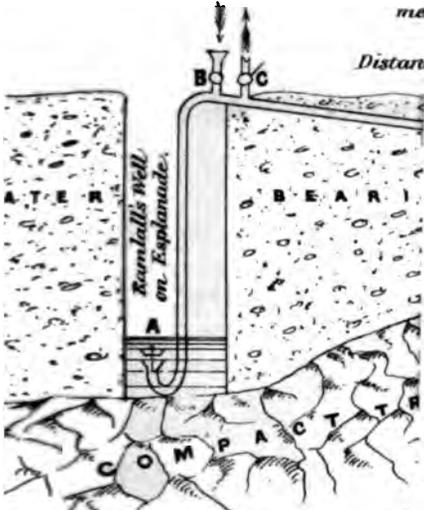

thin stratum of blue clay or one of Lo between the Littoral Concrete and the Ramparts

**PROPOSED
FILTERING WELL
IN
BABOOLA TANK.**

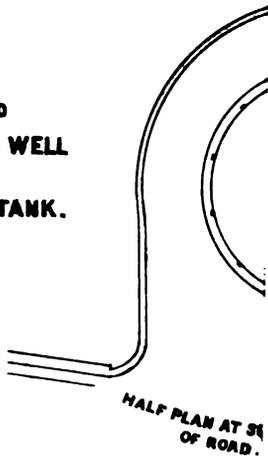

185

the Reservoir
sins in Gallons.

168,718,974
298,285,503
497,701,627
779,737,068
159,660,828
641,860,106
815,687,185
881,141,640
632,668,816
464,711,984
877,272,680
891,022,435
526,638,254
784,105,511
117,514,470

800,000,000*
853,000,000
950,132,838
553,421,335
051,351,036

ervoir—that
should im-
r site were
d a greater
ut the con-
7 expensive
; extent of
onstruction

nd were re-
nels “ along
orth of the

'beare's Report,
de Vol. 17, page



He also discussed the question of earthen and masonry dams, and decided for the former, chiefly on the consideration of cost.*

For the escape of the surplus water, he proposed a waste weir 340 feet long, situated alongside of the main dam (the site of the present weir), *vide Plate XXI*. The water was to be delivered by cast-iron pipes under pressure from Vehar, and the size of the main he proposed was 48 inches in diameter.

Mr. Conybeare recommended that the water should be filtered, and the accompanying sketch, *vide Plate XIX.*, with the following description of the filter, taken from his report, will explain the subject clearly:—

“The arrangement I propose.....consists of a filtering tower 50 feet diameter inside, rising from the foot of the inner slope of the dam, to the same height as the latter. It will be built of a highly porous littoral concrete, found along the west coast of the Island of Bombay and Salsette, and at many other localities along the Malabar coast. At intervals of six feet there will be bond courses of Porebunder stone pavement in two thicknesses, breaking joint with each other. The floor of the tower will be paved with stone, and thence the main conduit pipe will take its course, its inlet being closed at will by a single sluice. Directly this sluice is opened, the level of the water in the tower will sink, till the pressure is sufficient to force the water through the porous sides of the tower. I calculate that two or three feet difference of level will be sufficient for the purpose.” †

Forming part of Mr. Conybeare's Project was a Distribution Scheme for carrying the water by iron pipes to nearly all parts of the town. In most of the districts, the delivery was to be on the “constant service” system, with all the modern conveniences of fire-plugs, stand-pipes, &c. The out-lying villages were to be supplied by means of draw wells kept constantly full by small stoneware pipes or masonry conduits, in which the water was to be admitted from time to time through sluices in the main pipe so arranged as to deliver the water without pressure. Mahaluxmer, Malabar Hill, and Walkeshwar were to be supplied on the “intermittent system” during the night.

* This subject is fully treated of in No. LXVIII., Professional Papers on Indian Engineering, Second Series, by the present writer.

† It is fortunate that this plan was not carried out, for it is perfectly certain that a filter constructed on these principles would have stopped working in a very short time from the pores of the stone becoming choked up. Every one who has used self-filtering goglets made of porous stone, knows how admirably they answer at first, but how soon they lose all power to filter the water.

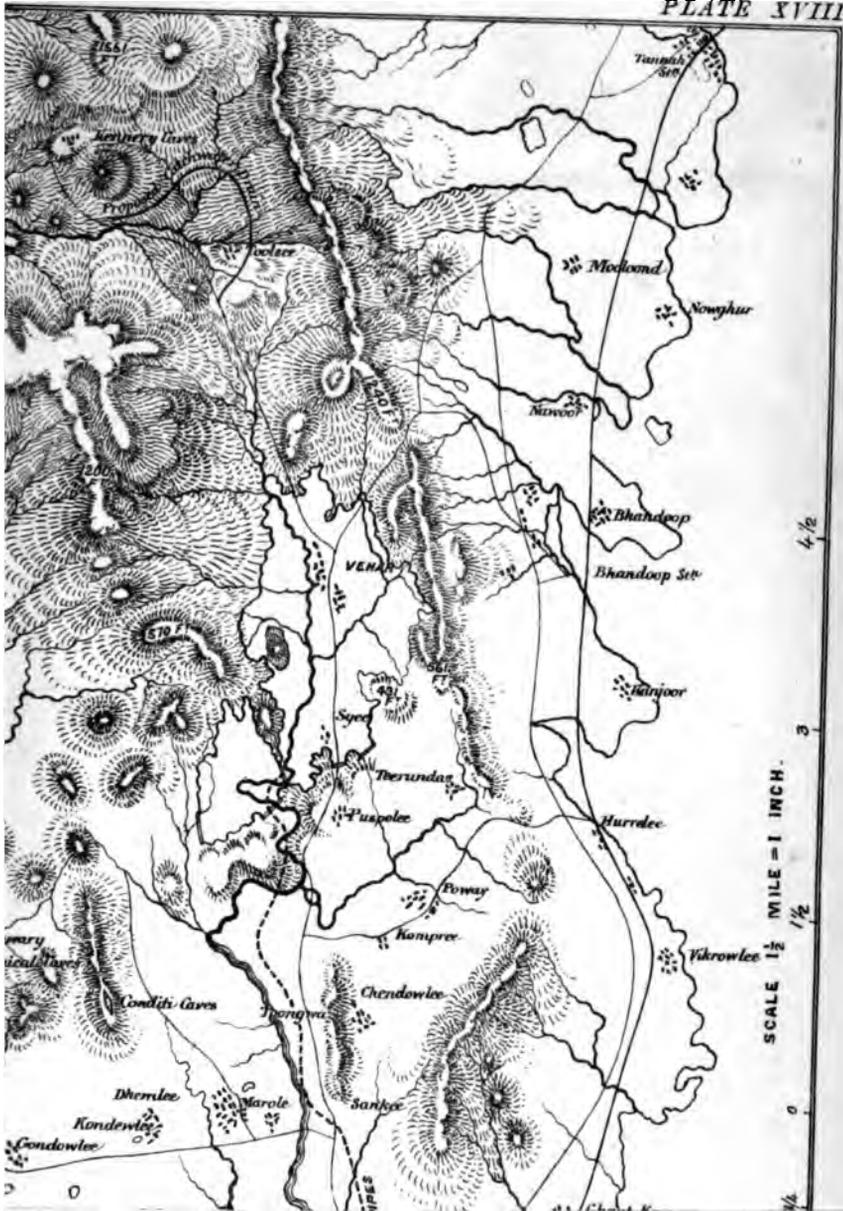



**METHOD PROPOS
FOR FILTERING, AND
FROM THE**

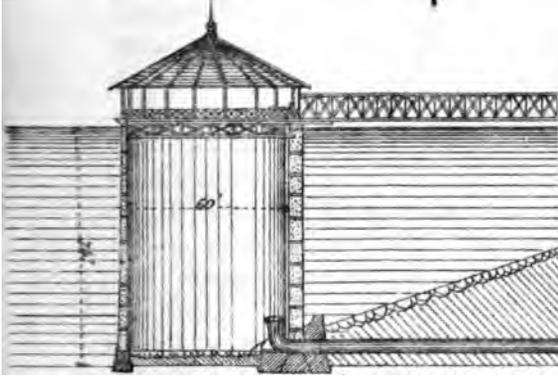



The cost of the works was estimated as follows:—

	£
Dams and Waste Weir,	17,411
Catchwater channel for extending the area of the gathering ground,	5,000
Filters and other Works at Reservoir,	4,302
Main Pipe,	159,820
Town and Village distribution,	48,173
	<hr/>
	234,206
Contingencies at 5 per cent.,	11,710
	<hr/>
Total,	245,916

After Mr. Conybeare's project had been prepared, it was submitted to Captain (now Major) Crawford, and he, on the 20th April, 1855, gave his general approval to the proposed works. Mr. Conybeare was then despatched by the Government, to England, where the design for the Outlet Works were altered, and some modifications, were made in the plans. The pipes were selected, and sent out under his directions. He never returned to India again. The contract was drawn out in England by the Hon'ble the Court of Directors, and was given by them to Messrs. Bray, Son, and Champney, of Leeds. Mr. Walker was appointed Resident Engineer, and Mr. Conybeare was made the referee for all disputes between the Government and the Contractors.

We now pass from the region of discussion to that of action. The Vehar project from an idea grows into a fact. It is necessary that I should describe the works as they were carried out.

The Vehar Lake, *vide Plates XVIII. and XX.*, covering an area of about 1,400 acres, and with a gathering ground, exclusive of the area of the water surface, of about 2,550 acres, is formed by three dams. Two of these were rendered necessary to prevent the water escaping over ridges on the margin of the basin, which were lower in level than the top of the main dam. The quantity of water supplied yearly by the reservoir falls considerably short of Mr. Conybeare's estimates,* and

* No blame should be attached to Mr. Conybeare for this. The yearly rain-fall at Vehar was unknown, and all he could do was to approximate to it from the only data at hand—*vis.*, the rain-fall at Bombay and that at Tannah. It is remarkable that although most people would have argued as Mr. Conybeare did, and concluded that the rain-fall on a height like the Vehar Valley would have exceeded that at Tannah, still this is not the case. Mr. Conybeare, although of the above opinion, yet, to be on the safe side, took, as already mentioned, 100 inches as the average rain-fall at Vehar, 124 inches being that at Tannah. Even this moderate quantity is probably above the actual one—90 inches as well as I can make it out from the records. The records, though, are unreliable.



The Plan exhibits two alternative sites for the principal Dam across the Goper. One N^o 3 at Fuspolee, the other N^o 5 at Syee. The contents of the Reservoir in each case would be as follows.

The Reservoir contains under the Fuspolee Datum.		Gallons.	The Reservoir contains up to the height above Fuspolee Datum of 4 feet.		Gallons.
Up to the height above Fuspolee Datum of 4 feet.		65,436			
8	2,211,806	8			
12	8,389,493	12			3,866,802
16	18,698,281	16			15,421,208
20	40,279,688	20			40,449,219
24	106,081,654	24			88,009,973
28	246,484,843	28			168,713,974
32	389,879,761	32			298,286,605
36	696,170,590	36			477,701,617
40	880,608,802	40			779,727,068
44	1,167,303,626	44			1,189,846,328
48	1,740,523,892	48			1,661,000,106
52	2,340,301,323	52			2,216,607,186
56	3,081,961,969	56			2,801,107,600
60	3,876,220,293	60			3,532,660,816
64	4,802,980,066	64			4,464,711,984
68	5,867,982,890	68			5,377,272,620
72	6,966,122,828	72			6,291,022,428
76	8,106,348,717	76			7,526,628,264
80	9,288,621,388	80			8,784,105,511
84	11,061,267,036	84			9,117,514,470
		88			10,000,000,000
		90			

The figures on the contour lines are their heights in feet above the Fuspolee Datum.

Vertical Equidistance of Contours 4 Feet.



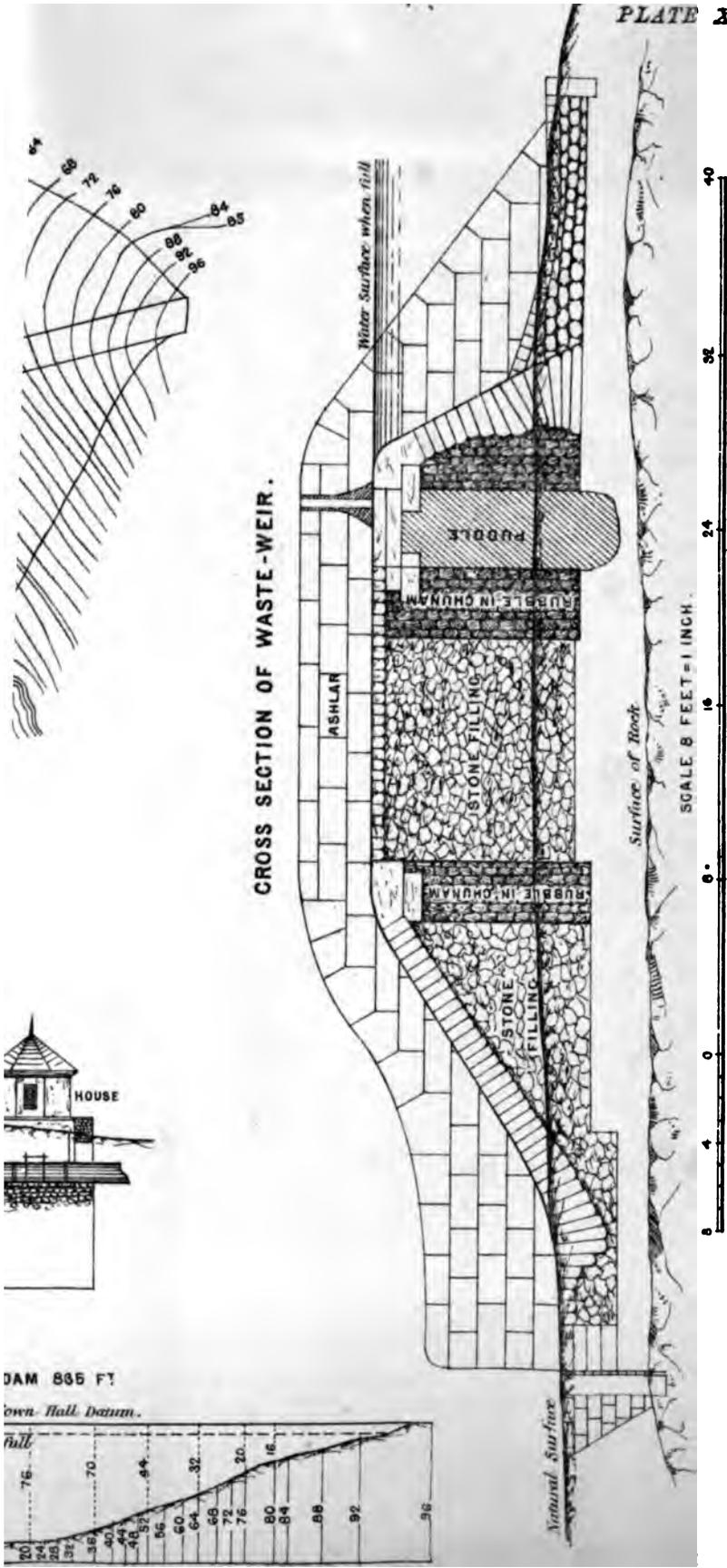

CROSS SECTION OF WASTE-WEIR.

DAM 865 FT

own Hall Dam.

Height (ft)	Width (ft)
76	20
74	24
72	28
70	32
68	36
66	40
64	44
62	48
60	52
58	56
56	60
54	64
52	68
50	72
48	76
46	80
44	84
42	88
40	92
38	96

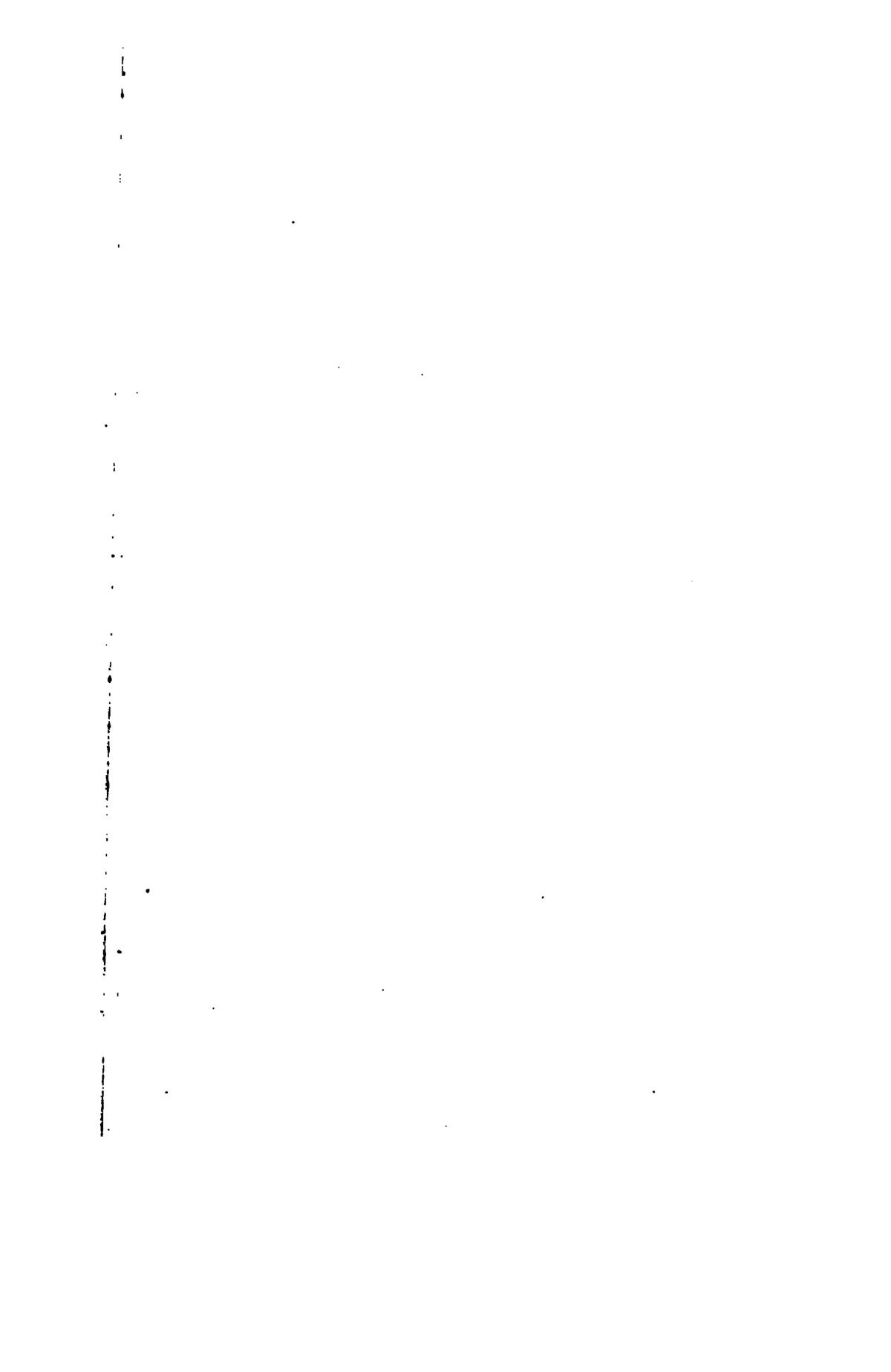

all the dams are pitched with stone. No. 2 Dam has a top width of 20 feet, and No. 3 Dam had the same width when constructed. But in consequence of the repairs carried out in 1871 to stop the leaks discovered in this work, the form of No. 3 Dam has been altogether changed, as will be seen by reference to *Plate XXII*.*

The following is a Table of the quantities of the different kinds of work in the three dams, as calculated by Mr. Conybeare :—†

Dams.	Extreme height.	Extreme length at the top.	Earth-work.	Puddle.	Total Earthwork & puddle.	Broken stones under pitching.	Rough stone pitching.
	feet.	feet.	c. feet.	c. feet.	c. feet.	c. feet.	a. feet.
No. 1, ...	84	835	255,706	80,910	286,616	997	26,993
„ 2, ...	42	555	43,617	10,332	53,949	327	8,827
„ 3, ...	49	936	106,743	14,717	121,460	659	17,797
Total,	406,066	55,959	462,025	1,983	53,617

The arrangements for drawing off the water from the lake, are as follows ‡:—The water is first strained through sheets of extremely fine copper gauze fixed to cages placed over the mouths of large pipes which pass into a masonry tower. In the bottom of this tower is fixed the mouth of the outlet pipe (41 inches in diameter) which passes under the dam, and conducts the water to Bombay. Two strainers are ordinarily sufficient to supply the tower with water as fast as it is drawn off by the outlet pipe and, as the purity of the water in the lake is in proportion to its nearness to the surface, the upper pipes are those always in use, the lower ones being kept closed with iron plugs.§

* In the working drawings, the main dam is shown as completed to about eleven feet, while it now stands about six and a half in the middle, and seven feet on the sides, above the weir. If the drawings are reliable, it follows that the dam has settled down from 4 to 4½ feet. I can give no information regarding Nos. 2 and 3 Dams, as these works have undergone repairs, and it is impossible now to say what their heights previous to the repairs were.

† *Vide* his paper on the "Bombay Water Works," Vol. XVII., Proceedings of the Institution of Civil Engineers.

‡ *Vide* *Plate XVIII.* of Vol. I., Professional Papers on Indian Engineering, Second Series, No. XXV.

§ In 1845 the lowest inlet was kept open. The water from the bottom of the lake proved to be of a reddish brown color, and great complaints were made of its unwholesomeness. Some time after its delivery in the town, cholera broke out in various parts, and when the cause was suspected, and the lower inlet closed, the epidemic at once disappeared.

Those who were in Bombay in April and May, 1871, will remember a sudden discolouration to a dirty

The outlet pipe (1½ inches thick) under the embankment rests on a firm foundation of rock or masonry, but, over it, I am told, there is only puddle. On issuing from the dam it bifurcates into two branches, each 32 inches in diameter, and on each branch is a sluice worked by a capstan arrangement. One branch goes on to Bombay, while the other stops with an open mouth about 200 yards from the sluice. The latter was intended for another main, when it became necessary to extend the water works.*

The line of pipes to the town is 14 miles long, and, excepting where it crosses streams, is placed under ground a few feet from the surface. The action of the earth on the metal tends to corrode the pipes very much. Layers of the oxide of iron three-eighths of an inch thick may often be removed from the surface.† The pipes are each 12 feet long, of the

brown tint of the Vehar water supplied to the town in those months. As the Department was engaged at the time in repairing some of the strainers, I was under the impression that the discoloration arose from unstrained water passing through the upper pipes; but, as the discoloration continued even after the repaired strainers had been put down again, I was quite at a loss to account for the fact. Remembering, however, what took place before, it occurred to me that water was probably being drawn off from too low a level. On inquiry, I found that three inlets were open. I closed the mouth of the lowest one, and, in a few hours, the water in the town resumed its usual transparency. It is quite clear, therefore, that the lower the water from the surface of the lake, the more impure it is, and that, for the proper supply of the town, the water near the surface only should be used.

It will be seen further on (page 188) that this statement is contradicted by my friend Dr. Lyon's analysis. I believe, however, that he is not himself satisfied that an analysis of the water taken in the dry months would be the same in character, as that which he has made of the water in the monsoon.

* The present sense of the Bombay community seems to be that the town should not be dependent on the Vehar lake alone for its supply, so that this branch line will probably never be laid down. It would be useless to do so without bringing more water into the lake from the Toolsee gathering ground, as the quantity of water now used yearly in Bombay is almost exactly that which the present gathering ground affords. The lake has overflowed only three times in thirteen years—twice to an insignificant—but once (1861) to a considerable extent. This overflow, though, was due to the fact that the distributory system in the town was at that time incomplete, and that much less water than the present quantity was being drawn off. Practically, all the water that has ever fallen on the gathering ground has been collected. The idea which has been put forward from time to time in the local newspapers, that more water might be obtained by a better system of distribution, is not correct. As all the rain which falls on the gathering ground is collected, and as, practically, none goes to waste over the weir, we must be using all we gather. If we were not, the surface of the lake would steadily rise year after year. But it does not. On the contrary, it keeps at one average level, or, if anything, it has a tendency to fall. At this present moment (April 1872), it is lower than it has ever been in this month since the construction of the lake.

† Occasionally, pipes are taken up in the town reduced to a state of graphite. The iron can be cut like the softest lead pencil with an ordinary penknife. This state of things is no doubt due to the action of saline matter on the metal. Some of the soils about Bombay are impregnated with salt. This is one among other reasons why I advocate that all pipes should in India be placed above ground. In England it cannot be done on account of the frost. If this difficulty could be got over there by jacking the pipes, I am certain it would result not only in their better preservation, but in an enormous saving of water. All leaks would be immediately discovered, and could therefore, be at once stopped.





spigot and faucet kind, and the joints are run in with lead. The thickness of the iron was intended to be from one to one and one-eighth of an inch, but there are many pipes not even three-quarters of an inch thick. The consequence is that we have numerous bursts of the main, when the town has sometimes to go without water for hours together.*

The greatest theoretic pressure of the water in the mains is about 180 feet, but the pressure actually registered varies between fifty and a hundred and forty feet. The "pull" begins at 4 o'clock in the morning with about 250,000 gallons per hour, and the consumption steadily increases till at 6 o'clock it attains a little over 400,000 gallons an hour. Up to about half-past ten there is no great variation, but about this time the consumption imperceptibly declines to a little under the above quantity. About 4 P.M. it begins again to increase, but very slightly, till half-past five, from which hour it declines steadily up to midnight, when only about 240,000 gallons an hour are used, and this rate of consumption continues till four in the morning. To put it in other words, the consumption begins at 4 A.M., reaches its maximum at six, continues at its maximum all day long, begins to decline at six in the evening, reaches its lowest at midnight, and continues at its lowest till four again the next morning.

The accompanying plans, *vide Plates XXIII. and XXIV.*, show the arrangements of distribution in the island. During the day no valves are closed. The entire system of pipes throughout the island is open to the flow of the water, but the practical effect of this is, that those parts of the town close to the mains and lying at a low level, monopolize the supply. In order to render the distribution fair, certain valves are closed at night, so that the districts far from the mains and situated at a high level may obtain their supply. This plan leads to great waste. Cocks are kept open all night, and thousands of gallons are lost to the public.

Originally the Vehar water was exceedingly pure, but I believe it has, during the last few years, deteriorated to some extent. Even now, however, I doubt whether there are many towns in England which can

* Some of the pipes were shockingly badly cast. There is part of one in the Municipal Office, not more than about $\frac{1}{8}$ th of an inch thick, and with a large hole in it through which for years a great quantity of water must have leaked. It was situated close to a sewer, so that the water escaped into the latter, and did not make its appearance as it usually does on the surface of the road.

boast a purer supply. The cause of deterioration is the great increase

Fig. 1.

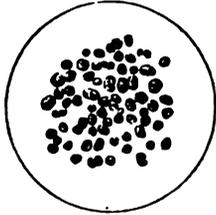

Protococcus magnified 850 diameters, from a sketch by Dr. Gray, of the Bombay Medical Service. pin.*

of vegetable matter in the lake, which is filled with myriads of plants of a low form of aquatic life, probably of the *Protococcus* class, one of the *Conservoid Alga*. It does not merely float on the surface, but apparently thrives at all depths, and it consists of a minute sporule which is sometimes as small as the point, and sel-

* From my own observations, I am led to believe, that unless some steps are taken to destroy these plants, they will go on increasing to such an extent, as will at last render our water-supply comparatively impure. To what cause they are due it is perhaps impossible to say. I cannot help thinking however that it may be necessary in a hot climate like India, where the generation and increase of all forms of life are so rapid, to empty our reservoirs at times. This appears to me the most effectual way of destroying the vegetation which poisons the water. Under present circumstances we could not empty the Vehar Lake, but this might be done if we constructed another reservoir.

It is remarkable that for some months before the monsoon, and until it sets in, the water in the lake is almost discolored by these sporules, but immediately the monsoon breaks, they disappear as if by the wand of the magician. In August 1871, I had difficulty in procuring even the few specimens from which the accompanying sketch was drawn. The obvious inference, of course, is that the influx of the fresh water destroys the sporules, but why so small a quantity of rain should produce such an effect it is impossible for me to say.

Regarding the deterioration of the water in the Lake, I should mention that the subject has occupied the attention of the Executive for some time past. Dr. Blaney, than whom no one in Bombay takes a deeper interest in the sanitary welfare of the town, and to whose intelligent exertions and disinterestedness the town owes so much, made what might have proved a valuable suggestion some time ago, but I regret to add that there is little hope of any success following its adoption. Doctor Blaney recommended that the plant "*Anacharis Alsinistrum*" should be introduced into the lake. The matter was referred home by us for any information that could be obtained regarding the effects produced by this plant on impure water. The London Water Companies, not being advocates for the employment of the plant, one of the very highest authorities in England was consulted on the subject. The following is Dr. Frankland's opinion :—

"In reply to your inquiries I have to say that, in my opinion, no beneficial results would ensue from the introduction of '*Anacharis*' or any other plant into the Reservoir or Lake. Living plants are of great use in ameliorating very foul waters, such as sewage, but they have very little effect upon moderately impure water like that contained in the Lake in question; moreover the continual decay of the older portions of the plant would necessitate the frequent cleaning of the reservoir, otherwise the quality of the water would become seriously deteriorated. Filtration through sand (5 or 6 feet thick if possible) is the most efficient means of purification of all foul water, on a large scale, hitherto discovered. It is desirable, however, that the filters should be allowed to run dry at least once a week, so as to allow the pores of the sand to become filled with air. Thus filtered and afterwards kept in covered reservoirs, the water of the Vehar Lake could not fail to be rendered good and palatable. I have read the memorandum by the Army Sanitary Commission, which was enclosed, and I entirely concur in the four recommendations of the Commissioners."—August 10th, 1871.

And again :—

"I have carefully perused the copy of Dr. Thomas Blaney's letter which you forwarded to me, and whilst I agree with the writer that plant life tends to purify water, so long as the plants and their leaves are alive and healthy, yet when the plants or their leaves die and decay, a serious pollution of

Fig. 2.

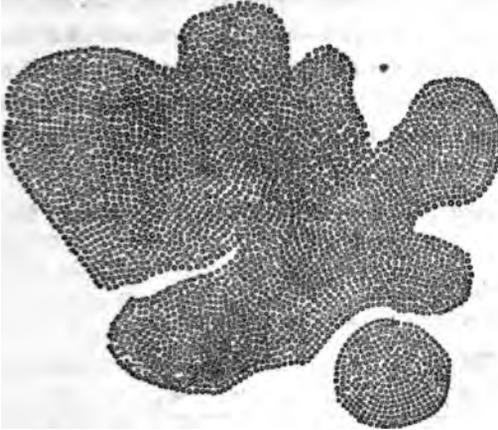

Appearance of one of the sporules under a microscope, magnifying 250 diameters, from a sketch made by myself.

In order to convey clearly to the reader the actual size of the sporule examined in the last case, I say, it was about half the size of one of the minute dots in Fig. 2.

Whether they escape after development in the lake through crevices in the tower, I cannot say, but at times they are found of a great size.*

the surrounding medium takes place, and the balance of effect produced is deterioration of the water unless the latter be originally excessively polluted. Moreover the *Anacharis* grows so luxuriantly and spreads from canal to canal with such rapidity as to become a serious nuisance and a source of considerable expense in the keeping open of canals and water-courses. Its introduction into India would consequently be a matter for grave consideration. Since its introduction into this country, I have never heard of any beneficial effect which it has produced; on the other hand, the inconveniences which it causes are constantly being complained of.

"I do not therefore find anything in Dr Blaney's letter which would cause me to modify the opinion I have expressed in my former letter."—October, 10th, 1871.

I should mention here that the difficulty of a sand filter, as recommended by Dr. Frankland, is, that in our case it entails a loss of pressure in the pipes, consequently a smaller delivery of water in the town. If the Bench were prepared to go to the expense of pumping the water on to a sand filter above the level of the Lake, to which there is no engineering objection, as the filter could be easily constructed, the water would be rendered pure with no deficiency in the supply. Or if the town were willing to do without filtered water in the event of a failure of the monsoon, then the filter might be put just below the level to which one year's consumption reduces the surfaces of the Lake. The loss of head of about fifteen feet would not entail a great reduction in the quantity of water delivered in the town, and practically, except for one year in ten or twenty, all the water used by the inhabitants would be filtered.

* Fishes have been found 4 feet long, and 12 inches round the body. Only the other day a dead eel was taken out of a pipe 4 feet 8 inches long, and 13 inches in girth.

Every now and then the water delivered through some particular pipe becomes exceedingly foul, and, when this is the case, the cause generally turns out to be some dead animal matter in the pipe. Fishes and eels often pass into the pipes, and, dying there, poison the supply. Whether they escape in the form of spawn through the strainers, and subsequently develop to full size in the distributing pipes, or whether they escape after development in the lake through crevices in the tower, I cannot say, but at times they are found of a great size.*

The following is an analysis of the Vehar water.* As the subject of its impurity below the surface has attracted much attention, the analysis is of samples taken at four different levels—at the surface, and at fifteen, thirty, and forty-five feet below the surface.† The water might fall to the fifteen feet level in the month of May or June after a total failure of the monsoon in the previous year, but could not sink to the thirty feet level except after two consecutive failures of the monsoon.

“ Results of the Analysis of four Samples of Vehar Water drawn 30th July, 1871.

A from the surface of the lake.

B from a depth of 15 feet from the surface of the water.

C “ “ 30 “ “ “

D “ “ 45 “ “ “

	A	B	C	D
Total solid matter Grains per gallon,	5·46	5·74	6·44	7·18
Loss on ignition “ “	·42	·28	·42	·42
Chlorine, “ “	·89	·79	·79	1·09
Hardness before boiling “ “	6·65	7·00	6·30	6·65
“ after “ “ “ “	5·60	5·60	5·60	5·60
Ammonia in distillate from carbonate of soda, ...	·0046	·0042	·0047	·0045
“ “ “ alkaline permanganate, ...	·0210	·0245	·0231	·0248
“ nitrates and nitrites,	·0126	·0210	·0126	·0126
Total oxygen required by the water at about 140° F. in presence of acid,	·0210	·0850	·0850	·0490

“ Sediment of much the same character in all four specimens—light brown in color and flocculent ; consists chiefly of vegetable debris, confervæ, a few parameria and altenophyrina also present. In no one of the four samples was the sediment abundant, but its quantity was sensibly greater in the samples drawn from the lower portions of the Lake.

“ I think the above results show that the water of the Lake is of nearly uniform quality down to a depth of 45 feet below the surface. The only important departures from uniformity are—1st, that the amount of oxygen required by the water increases with the depth ; and 2nd, that the amount

* It has been made for me as a personal favor by my friend Dr. Lyon, and because I could not obtain the information elsewhere. Those who attach importance to the good quality of our water (and who does not) as one of the great agents, if not the principal one of all, in maintaining the health of the inhabitants, and thus keeping down the death rate, will no doubt appreciate the value of this analysis, as it deserves to be appreciated.

† The surface of the lake when the water was taken from it for analysis, stood at twelve feet below high-water mark—i. e., at 250·50 on Town Hall Datum.

Of suspended matter (as noticed chiefly by vegetable débris) also increases with the depth.

“This is more than what one would expect from the conditions to which water stored in a large open reservoir like the Veihar Lake is subject. The first departure from uniformity of composition will remedy itself, for as the surface water is drawn away, the water below will become exposed to the action of the oxygen of the air, and the dissolved organic matters will become more fully oxidized by its influence. No apprehension need therefore be entertained on this score. The second point of difference between the deep and the surface water may possibly necessitate the adoption of some method of mechanical straining, should it ever become necessary to supply Bombay with water from what are now the lower depths of the lake. If this were done, or if the water supplied were filtered by the consumer (say through sand or sand charcoal), there need be no fear of inferior quality, at any rate down to a depth of 45 feet below the surface of the water as it stood on the 30th July, 1871.*

“As the health of Bombay so greatly depends on the purity of the Veihar water, it would be interesting to repeat experiments, similar to those of which the results are stated above, at some time during the hot weather, *i. e.*, before the lake has become disturbed by the influence of the monsoon.”†

It is impossible to gainsay the beneficial results to the town which have followed the introduction of Veihar water.‡ The best proof, perhaps, of its superiority to all other sources of supply in the island, such as tanks and wells, lies in the fact that, although the strongest prejudices existed in the native mind against its use, these prejudices have now all disappeared, and the native who cannot obtain Veihar water considers he has a just complaint against the Municipality.

Much has been said and written of the manner in which the works were carried out, but it is not my intention to enter on this subject, as no practical good could come of it now.

* This would be down to the level of 57·5 feet below the surface of the lake when quite full. As this is only 18 inches above the mouth of the lowest inlet, it follows that, practically, all the water which can by present arrangements be drawn off, would be fit for use.

† There is no doubt about the wisdom of this suggestion, for, as I have already pointed out in note on page 186, a most marked change comes over the lake shortly after the monsoon sets in.

‡ No one perhaps is more competent to speak on this subject than Dr. Blaney, who has resided in Bombay for more than thirty years—who must remember the state of the town under its old and primitive system of water-supply—and who knows so well its present condition.

It is sufficient for me to state that the cost of the Vehar Works, instead of being, as originally estimated, twenty-five lakhs of rupees, amounted with interest to the large sum of sixty-five and a-half lakhs of rupees.

Let it be remembered too that three-fifths (fifteen lakhs of rupees) of the original estimate was for a main of forty-one inches, and that the main laid down was thirty-two inches only in diameter. In spite of the reduction, therefore, which ought to have taken place in the largest item of the estimate, the works cost more than two and a-half times the original amount.

The Vehar project was commenced by the Government in the latter end of 1856—the main dam was completed in May, and the other two dams in August, 1858; by October, 1859, the lake was filled up to about 9 feet from the top of the waste weir—the delivery of water in the town commenced in March, 1860; by September the lake had risen to a point 5 feet higher than that which it had reached the previous year, and in July, 1861, it was quite full, and the water running over the weir. Since then it has continued to fall every season after the monsoon, reaching its lowest level about June or July, when it has continued to rise again, reaching its highest level sometimes as early as August, sometimes as late as October, but generally in September.

In order now to explain how the Municipality became connected with the Water Works, and its position with regard to the Government, I must break the thread of my narrative, and return to the year when the works at the Lake were nearly completed.

As the project was undertaken by the Government for the town, the Government of course looked to the town to reimburse them not only for the cost of the works, but for their yearly maintenance. In July, 1858, a new Act, known as "The Bombay Municipal Act," was passed, and in it the following Section* regarding the Water Works is found:—

"The Commissioners shall pay to the Governor in Council out of the Municipal Fund, an annual sum not less than one hundred and seventy-five thousand rupees, on account of the expense which has been or may be incurred by Government in the construction of the works called the Vehar Water Works; and such annual payment shall continue to be made until the whole of the expense so incurred (except such portion thereof, if any, as shall be defrayed by Government out of the public revenue), with inter-

* No. XXX of the Act.

est thereon at the rate of four per centum per annum, shall have been paid. The Commissioners shall also pay to the Governor in Council in each year, such further sum as shall be equal to the cost of the maintenance of the said works during the preceding year."

Up to 1868, while the town paid the expenses of maintenance, the works remained under the control and management of the Government, but in that year it was determined to transfer them to the town. A new Act, called "The Vehar Water Works Act," was passed, and in this, under certain pecuniary and other conditions, the Government yielded all their rights to the Municipality. It is most important that the Justices should know exactly in what position they are with reference to the Government in this matter. Without following the clauses in the order in which they are placed in the Act, the following summary will give a general idea of the scope of the Act, and of the existing relations between the Government and the Municipality.

It is forbidden to build or carry on any trade, manufacture, or agriculture within the watershed of the lake. All the works, including all the movable and immovable property, and all the public tanks and wells in the town, are vested for a term of ninety-nine years in the Municipality, which has power to alter, repair, or improve the works, or to enter any land or property for these purposes. Subject to the approval of the Government, the Municipality can levy rates and supply water to the town on such terms as it chooses. On the other hand, the Municipality is bound to keep a proper system of accounts, and to furnish an annual statement of the same for publication in the *Government Gazette*. It is also bound to maintain the works in proper order, and, if it fails to do so, the Government have power not only to supersede it by appointing others to the charge of the works, but to execute the repairs themselves under their own control, and at the cost of the Municipality. The surplus funds may, with the approval of Government, be expended in improving the works, and, when these funds exceed in a single year the sum of fifty thousand rupees, the Municipality may, but again only with the consent of the Government, alter the water rates. If the Municipality declines to do so, the Government can fix such rates as they choose, and these become binding on the town.

The pecuniary obligations attached to the transfer of the property were these. The Municipality was to be considered as a debtor to the Govern-

ment, to the extent of a sum of money equivalent to twenty-five lakhs of rupees in addition to half the cost of the works above this sum. As, at the time of passing the Act, the works had cost with interest about sixty-five and a-half lakhs of rupees, half the excess over the twenty-five was about twenty and a quarter lakhs, so that the total debt in 1863 was represented by forty-five and a quarter lakhs, less the payments which had been made by the Municipality up to that time. As these amounted to about seven and three-quarter lakhs, the actual total debt in 1863 was thirty-seven and a half lakhs of rupees. The Act, however, put it at Rs. 37,30,053. To liquidate this, the Municipality is bound to pay the Government every year the sum of one hundred and seventy-five thousand rupees, until the entire debt is expunged, when the works will, for the remainder of the lease, belong to the town. If on the 1st of July in any year there is a failure of payment, the Government, after giving two months' notice thereof, can seize the water works, and manage the property themselves.

The following is a condensed statement of the Vihar debt from the commencement, and made up to the 1st January, 1872 :—

	RS.	A.	P.
Amount disbursed in England for stores and other charges,	17,78,316	15	6
Amount disbursed in Bombay,	38,47,642	11	10
Simple Interest on do. at 4 per cent from the different dates of payment,	9,58,829	11	7
Total charges,	65,84,789	6	11
Deduct Refund, sale proceeds of stores, &c.,	40,902	7	5
Actual cost of works,	65,43,886	15	6
Deduct amount of original Estimate,	25,00,000	0	0
Total,	40,43,886	15	6
Moiety of the above excess,	20,21,943	7	9
Add amount of original Estimate,	25,00,000	0	0
Total,	45,21,943	7	9
Deduct payments made up to 30th June, 1863,	7,71,438	5	8
Total,	37,50,505	2	1
Deduct amount struck out in adjusting the charges against the Municipality to accord with that specified in Act II. of 1865,	20,452	3	1
Total Vihar Debt on 1st July, 1863,	37,30,053	0	0

	RS.	A.	P.
Carried forward,	37,30,053	0	0
Add accumulation of interest up to 1st January, 1865, with amounts disbursed by Government, less Instalments paid up to this date,	1,85,727	2	4
Total,	88,65,780	2	4
Deduct Instalments paid between 1st January, 1865, and 31st December, 1871, less interest up to the latter date,	1,29,292	2	4
Total Vehar Debt on 31st December, 1871, ..	87,36,488	0	0

To ascertain what the debt should have been with which the Municipality ought to have started, we must bear in mind that the actual cost of the works, without interest, was 56 lakhs of rupees. A moiety of the cost above 25 lakhs is 15½ lakhs. If to this we add 25 lakhs, the amount of the original estimate, the total debt at starting ought to have been about 40½ lakhs. The excess over this in the above statement is caused by the addition of interest. Comparing the original debt with our present liabilities, it will be seen that we are not very far off from the position we originally occupied. I will now show when our liabilities will cease.

As the interest on the debt demanded by the Government is four per cent., it follows that out of the Rs. 1,75,000, Rs. 1,50,000 go yearly towards defraying this charge, and consequently Rs. 25,000 only go towards the reduction of the principal. The Bench, therefore, are reducing the debt at this present moment by Rs. 25,000 yearly, plus the interest on this sum, or altogether by Rs. 26,000. As the principal and the interest decrease, so the rate of reduction of the debt increases, and, if the payments are continued as at present—viz., monthly—the debt will be expunged about the year 1920.

There is a general feeling among all classes that the Municipality has been hardly dealt with by the Government, and is made to pay more than it should be legitimately called upon to do. In fact, ever since the delivery of the water in the town, the sick man has not only revived, but has begun to grumble at the doctor's bill. At first he expressed his feelings in mere mutterings, but of late he has denounced what he considers the imposition of the Government in very strong language.* His idea is not only that he has to discharge a heavy bill, but that the works, with the carrying out of which he had nothing to do, are in such an insecure

* *Vide* the Proceedings of the Bench in 1869, 1870 and 1871.

state, as to render the further expenditure of money imperative on him. I, too, was at one time under the impression that the Government had not acted with fair consideration for the interests of the town, but I am bound to admit that a careful study of both sides of the question has convinced me there is no reasonable cause of complaint on the part of the Bench. In order to prove the case, it is enough to ask the simple question, "What is it that the Municipality complain of?" Is it of being saddled with the Vechar debt; and if so, are they willing to hand over this to the Government, *along with the revenue derived from the Water Works?* If they are, I must be candid, and say plainly that they are contemplating a very foolish thing, and I will prove why it is so.

The Vechar debt is about Rs. 37,50,000. The annual revenue derived from the works now is Rs. 3,80,000. Of this latter sum Rs. 50,000 go towards maintenance and extensions, and there is consequently a balance of Rs. 3,30,000 left to the Municipality. At present they pay the Government Rs. 1,75,000, and pocket the remaining Rs. 1,55,000. Now, if they quarrel with the Government, and the Government turn round and say, "Very well; we will relieve you of the Vechar debt and also of the revenue," what will be the state of things? Simply this, that the Government will obtain Rs. 3,80,000 yearly to repay themselves for the Rs. 37,50,000. In other words, they will be in the position of a company obtaining nearly nine per cent. on their speculation. Surely it is more sensible for the Municipality to pay the Government Rs. 1,75,000 (say five per cent.), and to secure the remaining Rs. 1,55,000 (about four per cent.) for themselves.

My advice to the Bench, therefore, is to let well alone—to accept the debt, and to raise the revenue in every legitimate way, applying all surplus above the cost of maintenance towards new works, which, indeed, are urgently needed.

On one point only do I think the Bench may fairly ask for a remission of the terms from the Government. According to the Act, and even if the entire debt is discharged, the Vechar works revert to the Government after ninety-nine years. It is, perhaps, not likely that the Government would really claim them, but still the power to do so should not be left to them. The Bench should urge that if the debt is repaid, the works shall become their own absolute property.

The insecurity of the Vechar Dams, the dependence of the town for its

Supply of water on the durability and strength of the single line of pipes under No. 1 Dam, and the impossibility of repairing this pipe if it should give way (as it must ultimately in the course of nature, and may at any moment), have all contributed to render the public dissatisfied with the existing state of things, and have determined them to rectify it by obtaining a further supply of water from some other source.*

* "A time must come when the 41-inch iron main running through it (No. 1 Dam) must be worn away. No arrangements were made in the construction of the dam to enable the Engineer to put down another main when this one became useless. Should a leak ever occur in this main under No. 1 Dam, it will be a most serious matter for the town, and the very worst consequences may be expected.

"The pipe lies about seventy feet from the top of the Dam, and there is a pressure of from 63 to 80 feet of water on it, dependent on the lake being full or otherwise. Suppose there is a burst in the main (and this supposition is no extraordinary one), water will issue from the pipe with a pressure of say 25 lbs. on the square inch. What the effect of a stream passing with a velocity due to this pressure will be on the surrounding earth it is hardly necessary for me to explain. Material must be washed out from the dam by the water in its outward course, and after this has continued for a short time, the stability of the work must be destroyed. To repair a leak of this nature in the manner which I have adopted to render Nos. 2 and 3 Dams secure (that is, by dropping a vertical puddle wall down into the natural soil through the exterior slope of the dam) will be not only attended with great risk, but impossible, unless the supply to the town is stopped for several consecutive weeks. This fact, therefore, must be looked in the face—viz., that a time must come, sooner or later, when from the pipe under the embankment being worn away (as all iron ultimately wears away), and from there being no means of substituting another pipe in its stead, the inhabitants of Bombay, unless they furnish themselves with some other source of supply, will have to pass through a water famine.

"The question is really a very serious one for the community. The arrangements for drawing water from the Vehar Lake are most imperfect. The masonry of the tower leaks so badly, that I am told an attempt which was once made to examine the mouth of the outlet pipe at the bottom, nearly resulted in the death of the diver, who was almost forced into the pipe by the quantity of water falling on him from above. It will thus be seen that to close the mouths of the strainers, does not render the tower dry. It follows, therefore, that if a pipe bursts under the embankment, it will be impossible to discover the point of fracture by sending a man down the tower. The only thing to be done in this case will be to block up the mouth of the outlet pipe, so as to prevent any water entering it. Even this may be attended with difficulty, but if it is successful, the next thing will be to send a man into the pipe through the sluice valve at the outer foot of the embankment. If a real fracture of the pipe has taken place, it will not perhaps be difficult for a man to discover its position, but if the leak were due to an imperfect joint, no examination of the pipes from the inside could enable a man to discover its locality.

"Under these circumstances, I cannot but draw the attention of the Bench to the risk they are running in delaying to construct proper outlet works for the Vehar Lake—works which should have no connection with any of the dams, and be so arranged, that any defective portion may be repaired without difficulty or danger.

"But in either case, whether the iron is fractured or whether the joints have separated, it will be impossible to repair the pipes from the inside. And let the pipes be repaired in any way whatsoever, the supply to the town must be shut off for weeks." *"Extract from my Report on the Vehar Lake Dams."*

"I think the Bench should thank Capt. Tulloch for the very moderate report he has written upon the Vehar Dams. There is nothing exaggerated, but on the contrary, I think he has missed one point, which is the point we must look at now. I think that during the dry season the puddle dam must be completed, but the most difficult thing will be the pipe. Now I will try to explain. I could do it better upon a black board, but I will endeavour to do it orally. The danger that there is in connection with this pipe is this: that there has been, for several years probably, a leakage through the dam at the supply pipe, and it is certain the leakage is not at the top, and it is equally

In July 1868, Mr. Russel Aitken, the Executive Engineer of the Municipality at that time, in compliance with instructions from Arthur Crawford, the Municipal Commissioner, submitted a "Report on the Extension of the Bombay Water Works." In this Report he proposed four different schemes for consideration.* Of the first he wrote

"The hills on the mainland in the immediate vicinity of the north-western part of the Island of Salsette do not present any facilities for the construction of reservoirs, as they either cannot give sufficient supply of water, or they are not situated at a sufficient height to allow of the water having the necessary fall towards the city.

"Being unwilling to abandon the search, the survey parties explored the streams until, at last at Shewla, in the talooka of Moorban, about 12 miles from Bombay, a site for a reservoir was found, which fulfilled the required conditions, *vide Plate XXV.*

"If the cost of all works for the improvement of the sanitary condition of the city is to be defrayed from loans to be raised on Municipal revenue, it will be absolutely useless for me to say any more about a scheme which would be so expensive as the Shewla Scheme. Nevertheless

certain it is at the bottom of the pipe. You cannot have water running even on a level without the rock being gradually worn away. And although no perceptible amount of mineral deposit has been found in the water, there is no doubt in my mind that a small quantity coming through from under the pipe, and that there is a considerable cavity under it. Should the pipe or other the pipe must break, and then there will be the whole pressure of the Veihar water through the aperture in the earth." Mr. Ormiston concluded by recommending the Bench no expense in carrying out the repairs on the plan Capt. Tulloch had commenced, and to well the scheme which Capt. Tulloch intended to bring forward for a separate outlet. It many years before new water works could be ready, and he thought no means should be rendered secure the present dams at a reasonable expense." *Extract from Mr. Ormiston's Speech at the Meeting of the Justices on the 12th August, 1871.*

* In order to prevent confusion, I should mention that in his levels of the Veihar Lake, Mr. Aitken has an error of nearly 15 feet. The waste weir of the lake is not, as he has it in his plans above mean sea level, but 182.20 feet or 262.50 feet on Town Hall Datum.

It is a great pity Mr. Aitken did not work to the same datum as the rest of the plans of Bombay, *viz.*, the Town Hall Datum. He took as his datum a point fifty feet below mean sea level. But the exact level of mean sea is disputed, and it is most confusing to fix as a datum a point which there is any difference of opinion. The person best capable of speaking on the subject is Mr. Ormiston, who has taken a series of tidal observations, and he makes mean sea level more than half a foot higher than the point fixed by Mr. Aitken. Mr. Ormiston's mean sea level is 80.80 on Town Hall Datum, whilst Mr. Aitken's is 79.70. My motives in condemning this datum, against which Mr. Ormiston has, with his usual judgment, protested, will not be understood when I add that I myself am to blame in the matter for having in my Drainage and in the plans of the Toolsee project adopted Mr. Aitken's mean sea level datum. My mistake was that until Mr. Ormiston expressed to me his objection to the datum in the Toolsee project, I was not aware that there was any generally recognised datum. But having helped to add to the confusion, I unhesitatingly make my apology to the profession, and I have endeavoured to atone for my error by reducing the drawings in this report to the now universally accepted Town Hall Datum.

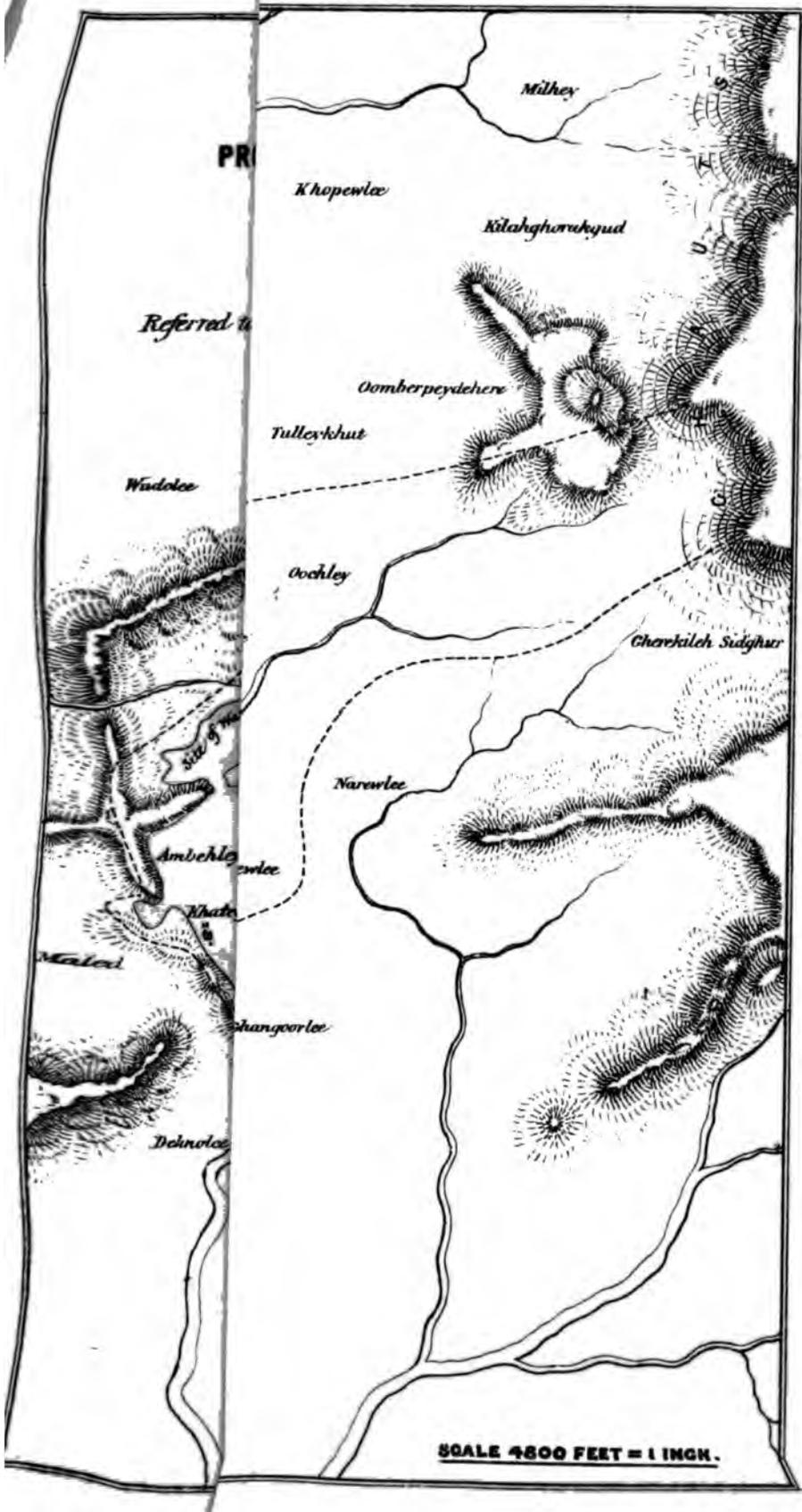

.....

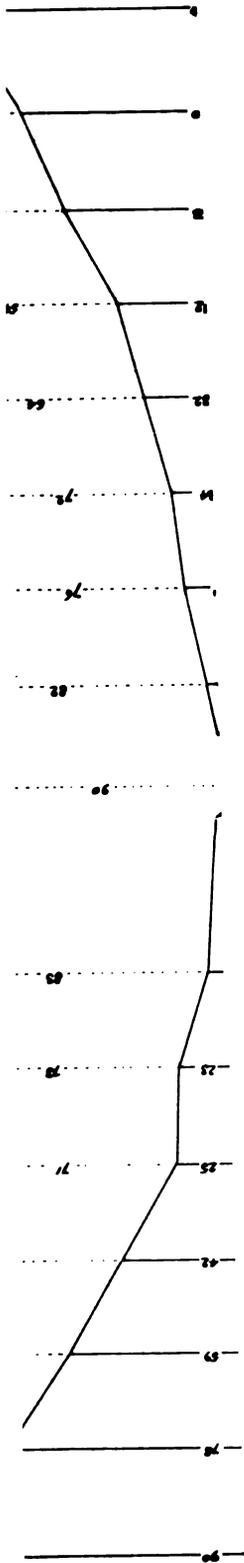

natural
lity can-
g water,
lgational

XXVI.,
of water
square
pas.
onstruct
nt. more
phar."
ster into
masonry

r of the

is worn
twice its

2
1
0
-
3

he Tas-
roposed
of the
har. I
mpound
a very
h I am

was not

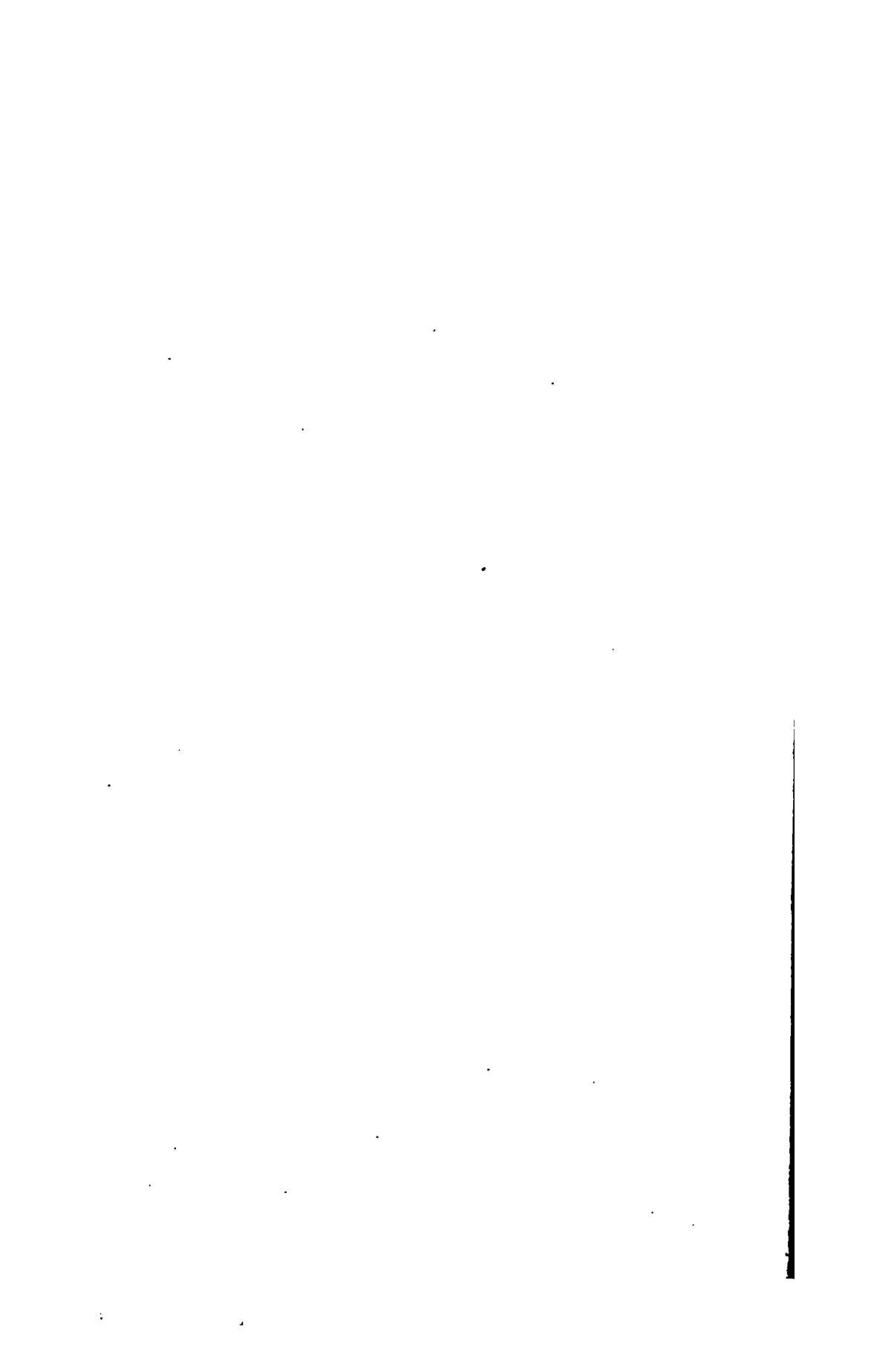

consider it my duty to lay the entire project before you, as the natural advantages of the Valley are so great, that even if the Municipality cannot make any use of the facilities which it presents for impounding water, perhaps Government may be able to construct a reservoir for irrigational purposes.

“The total area of the proposed lake with a dam (*vide Plate XXVI.*, for information regarding the dam) 96 feet high, or with a depth of water 90 feet above the bed of the stream, would be not less than $6\frac{1}{4}$ square miles, or 4,000 acres, whilst it would contain 33,000 million gallons.

“The quantity of earthwork, &c., which would be required to construct the embankment would be 687,000 cubic yards, or only 30 per cent. more than the total amount of earthwork, &c., in the three dams at Vehar.”

From this reservoir Mr. Aitken proposed to bring the water into Bombay through a steel main $4\frac{1}{2}$ feet in diameter, and carried on masonry pillars.* The contemplated supply was 25,000,000 gallons daily.

To meet the objection, suggested by himself, that the character of the works was not of a permanent nature, Mr. Aitken said:—

“I have no doubt but that when the proposed 4-feet 6-inch main is worn out, Bombay will be ready and able to pay for a new main of twice its capacity.”

The cost of the Shewla Scheme was as follows:—

Reservoir and works at Shewla, including 10 per cent. for contingencies,	RS.
Steel main 56 miles long, including do. do.,	10,97,292
Land,	1,24,78,611
	4,49,280
Total,	1,40,25,183

Or say $140\frac{1}{4}$ lakhs of rupees.

The Second Project proposed by Mr. Aitken was:—

“The construction of an entirely new reservoir in the valley of the Tassoo River just below the Kennery Caves. The total area of the proposed lake, which will hereafter be called the Kennery reservoir, and of the gathering ground, will be nearly 3,400 acres, or about equal to Vehar. I propose that the embankment shall be 136 feet high, which will impound water to a depth of 130 feet above the bed of the stream. This is a very great depth of water, and is 22 feet higher than any dam with which I am

* I cannot give a plan or section of the line along which the main was to run, as they were not given by Mr. Aitken himself. In fact, there was no survey made of the line.

acquainted; yet as there is an abundance of excellent material in the immediate vicinity of the dam, and as we can supply ourselves with it for consolidating and working it by pumping from Vehar, I should have no hesitation in undertaking the work, nor should I entertain any doubt as to its perfect success.*

“The total amount of material required for the construction of the dam, *vide Plate XXVII.*, amounts to no less than 1,110,000 cubic yards, nor would it be possible to do with a less size of dam than is now proposed, as otherwise, owing to the configuration of the ground, we should be unable to impound the requisite quantity of water.

“The area of the proposed Kennery reservoir is only 500 acres in extent, or less than one-half that of Vehar, and its storage capacity is only 7,400 million gallons, or one-third less than Vehar. The total amount of supply available for the use of the city will, however, amount to 4,000 million gallons.”

The Third Scheme which Mr. Aitken proposed was:—

“The construction of a dam in the River Tassoo† just below the village of Toolsee, whereby the waters of the upper portion of that river will be diverted into the Vehar Lake, which would thus have its gathering ground increased by 1,600 acres, so that the present supply from Vehar might be increased from 5 to 6½ million gallons.

“A new 28-inch main pipe will be required to convey to Bombay an extra quantity of water, and I estimate the cost of this work at 16½ lakhs of rupees, or from 5½ to 6½ annas per gallon.

Of his Fourth Scheme Mr. Aitken wrote:—

“It embraces Scheme No. 3, but in addition to the supply to be obtained from the upper part of the Tassoo, I propose to construct a new reservoir at Poway, *vide Plate XXVIII.* A reservoir can be constructed in the Poway valley 980 acres in extent, and the total amount of earthwork for the dams will amount to but 380,000 cubic yards. The Poway basin presents very great facilities for the construction of a large reservoir, unfortunately the gathering ground is very limited, being only about

* In connection with this subject, *vide* Appendix B, No. LXVIII., of Professional Papers on Irrigation Engineering, Second Series. Mr. Rankine our highest authority in the theoretical branch of the profession, doubts whether an earthen dam can be relied on where the depth of water exceeds 110 feet. *Vide* also page 72 of the above-mentioned Article.

† The survey of this valley had not been made when Mr. Aitken submitted his Report. It was completed shortly after my arrival in Bombay in June 1870. A plan of both the Toolsee gathering ground and reservoir is given in *Plate XXIX.*

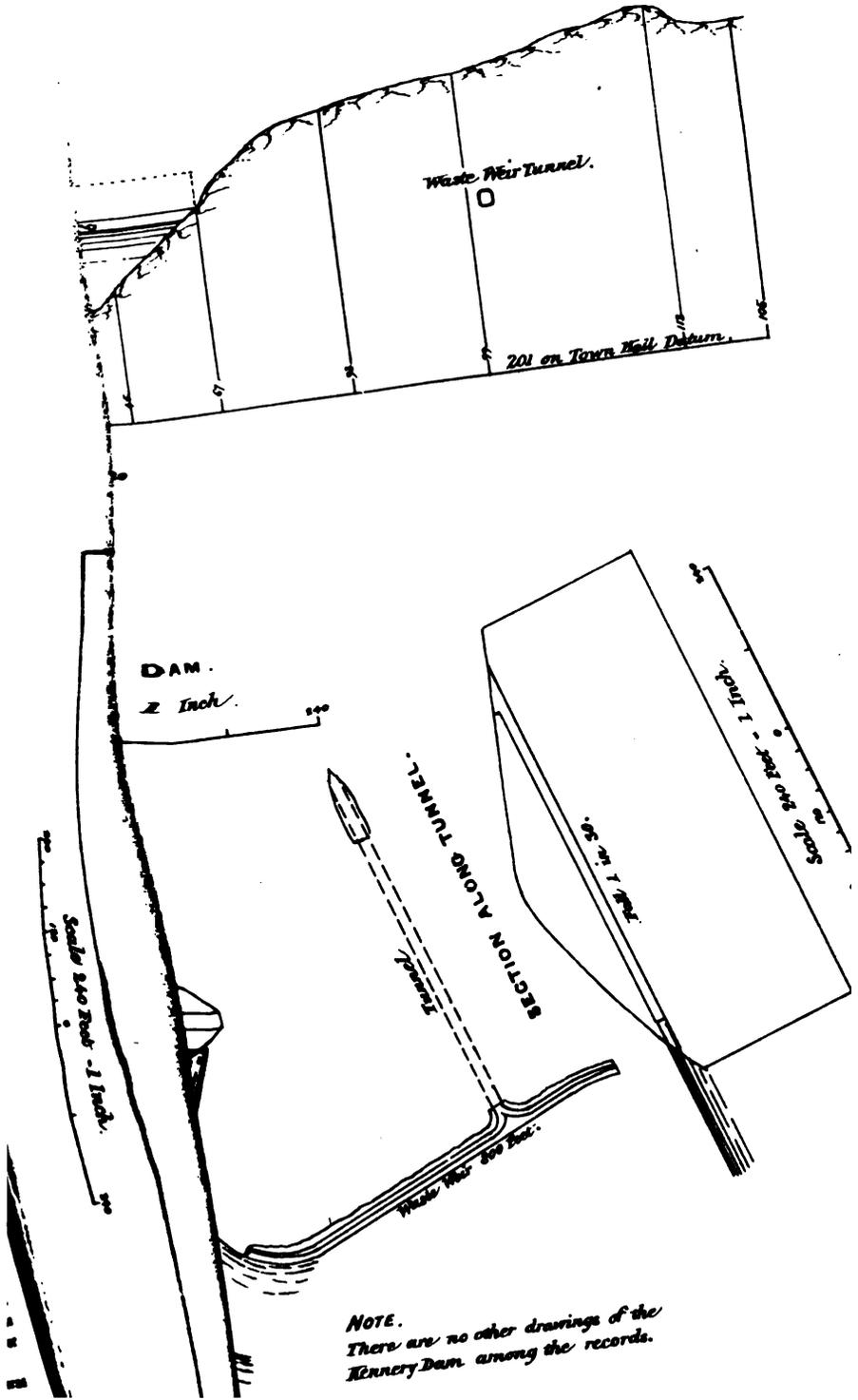



/

1
2
t
e

same area as the Lake. This deficiency would, however, be supplied by running the surplus water from the Vehar Lake into the Poway reservoir.*

“If this scheme be carried out, 10 or 12 gallons per head may be secured at a cost of about 35½ lakhs of rupees.

“The size of the main from Poway would require to be 36 inches in diameter to enable us to work it along with the supply from Vehar, and as we could depend on the Vehar Lake being filled every year, I would propose to lay another 32-inch main from Vehar, to join this proposed new main from Poway.”

In forwarding Mr. Aitken's Report to the Government on the 12th October, 1868, the Municipal Commissioner said: “I must reluctantly pronounce the construction of the Shewla Scheme pecuniarily impossible to Bombay at present,” and Mr. Crawford recommended the carrying out of the Kennery Scheme at the cost of 41½ lakhs of rupees. The financial view of the question taken by him was put thus:—

“The present income from the Vehar water rate is four lakhs of rupees. Of this one and three quarter lakhs goes towards payment of the Vehar works, and one lakh is needed for maintenance and minor extensions. This leaves one lakh and a quarter annually available for the construction of new works.

“I assume that Government would treat Bombay like Calcutta, and obtain the money required on its own guarantee, at 4 per cent.

“The re-payment of the loan should be spread over 50 years, and, besides interest, one-fiftieth should each year be set aside as a sinking fund.

“To construct the Kennery works, the sum of Rs. 41,50,000 is required.

	RS.
Interest at four per cent.,	1,66,000
One-fiftieth for sinking fund,	83,000
	2,49,000
Total, ..	2,49,000

“I would provide this amount partly from the excess of the existing water revenue over expenditure, and partly by a light general water rate, which should be made leviable by law for 50 years, thus—

	RS.
Excess available,	1,25,000
One per cent. water-rate,	1,32,000
	2,57,000
Total, ..	2,57,000”

* I cannot give drawings of the dams of which there were to have been six. Excepting a longitudinal section of the main dam, copy of which may be seen in *Plate XXVI.*, there is no information on record regarding these works.

In a Resolution passed on the 12th January, 1869, the Government appointed a Commission of the following gentlemen to take evidence and report on the Water-supply and the Drainage of Bombay: The Hon'ble A. R. Scoble, Chairman, Colonel W. Kendall, Lieut.-Colonel J. S. Trevor, R.E., Dr. W. G. Hunter, M.R.C.P. With reference to the former subject the duty of the Commission was:—

“To consider Mr. Russel Aitken's scheme for increasing the water-supply, and to report on their relative general advantages, and to examine and discuss the details of that which they might consider most suitable, should they be of opinion that either of them was calculated to effect satisfactorily the object in view.”

The Commission sat for the first time on the 17th March 1869, and continued its sittings till the 7th of April following. At this stage in the history of the water-supply of Bombay, I became a party to the discussion. I gave evidence before this Commission, but I took an unfavorable view of all Mr. Aitken's projects. It is not my intention, however, in this report either to support my propositions or to criticise Mr. Aitken's schemes. I shall, therefore, merely state the conclusions at which the Committee arrived, and so far as possible in their own words. I beg to draw especial attention to these conclusions, as I think they are most worthy of consideration, and display a largeness of view on this important subject, which it behoves the town to weigh well. Regarding the Shewla Scheme, they wrote thus:—

The Commission consider that it is too gigantic a work to be undertaken by the Municipality. Its cost would appear, if anything, to have been under-estimated by Mr. Aitken; for Mr. Ormiston puts it at two millions sterling, and Captain Tulloch at 180 lakhs. The proposal to carry the water for a distance of fifty-six miles in an exposed steel is also, in the opinion of the Commission, too novel an experiment to be tried on so large a scale in the first instance; and, without adopting Dr. Blaney's opinion, that the water would ‘come into Bombay in the afternoon in a state for boiling an egg, warming a child's conjee, or giving a rheumatic patient a hot bath,’ the Commission have no doubt that should it be found necessary to bring water into Bombay from so great a distance, a masonry conduit would be in every respect preferable to a steel main.”

Of the Kennery and Poway Schemes they said:—

“The Kennery and Poway schemes are both open to the objection

that they are mere patches upon Vehar, and incapable of extension from time to time to meet the growing requirements of the city. The enormous height of the impounding dam at Kennery, and the quantity of valuable land that would be submerged at Poway, are additional reasons against the adoption of either of these projects; and the Commission are of opinion that neither of them is calculated to effect satisfactorily the object in view."

After this expression of opinion on three of the projects proposed by Mr. Aitken, the Commission discussed the general question as to the quantity of water required by the population, and the quality of the water obtained both from Vehar, and from the wells in Bombay. They showed how the 8,500,000 gallons supplied daily to Bombay were expended, and, condemning generally the water obtained from the tanks and wells in the town as "fruitful sources of disease and death," pronounced the "only really wholesome water" to be that "from the Vehar Lake." They then went on to say:—

"Under these circumstances, having been obliged to discard the three larger projects suggested by Mr. Aitken, the Commission directed their attention to three points:—

- (1). Whether the existing works at Vehar are in a safe condition.
- (2). Whether the supply from Vehar can be increased without danger.
- (5). Whether the Vehar water is so distributed as to make it most generally useful.

"There is no doubt that so long as Bombay has to depend on one reservoir for its water-supply, it runs a great risk, 'on account of the general insecurity which attaches to all works of the kind.' But, apart from this, there seems no special reason to distrust the stability of the works at Vehar. Mr. Ormiston says that 'the dams are in a better state than they have been in for many years,' and that 'the repairs which Mr. Aitken made two seasons ago at the Vehar dams have been so efficient, that, so far as my judgment goes, the Bench need not expend the two lakhs which are put down for extra repairs.' He, however, considers it a source of danger that the outlet pipe at Vehar passes through the embankment; and that it might be closed altogether, and a fresh one put in at a higher level, with great advantage. Captain Hancock says that 'it is desirable that the dams should be very carefully overhauled, and perhaps, repaired,' but that 'there is nothing to prevent the necessary

repairs being carried out to make the dams sufficiently strong to be depended on.' And Mr. Russel Aitken, though saying that 'the same feeling is entertained by every one connected with the works, namely, that they are not in a satisfactory state,' reports that, with an expenditure of two lakhs, the dams and waste weir can be made reasonably safe.

"The Commission are therefore of opinion that there is no reason to expect any immediate accident to the Vehar works, and that, with a moderate expenditure, the dams may be made as secure as is possible to make works of such a nature. They accordingly recommend that these repairs should be taken in hand without delay. As a further precaution, they would advise that the present outlet pipe through the dam should be closed, and a new one put in through the solid at a higher level.

"The supply from Vehar being equivalent only to about 10 gallons daily per head of the population—the pressure being insufficient for continuous service—and, as a consequence, the mains being frequently empty on occasions of fire,—the Commission considered it most important to ascertain whether the quantity of water in the lake could be supplemented from neighbouring sources, without danger to the existing works. This, in the opinion of the Commission, can be accomplished by Mr. Aitken's Toolsee scheme. He proposes 'the construction of a dam in the River Tassoo, just below the village of Toolsee, whereby the water of the upper portion of that river will be diverted into the Vehar Lake, which would thus have its gathering ground increased by 1,600 acres, so that the present supply from Vehar might be increased by 5 or 6 gallons per head daily.' Mr. Aitken is of opinion that, if the dams at Vehar are strengthened as recommended by the Commission, the Toolsee water can be brought into the lake without any danger; and in this opinion Mr. Ormiston and Captain Hancock concur. This increase would bring the water supply of Bombay up to from 15 to 16 gallons per day per head of the population, and could be effected at moderate expense; Mr. Aitken estimates the work at 16½ lakhs, including the cost of a second main from Vehar to Bombay.

"The Commission recommended the adoption of this scheme, not only because, so long as the Vehar dams last, it will give an increase of 50 per cent. to the water supply at a small cost, but also because it appears, from Captain Hancock's evidence, 'that the supply of water to the Vehar Lake is not much more than sufficient to meet the presented rain upon it

in average years,' and that, if succession of years of low average rain-fall were to occur, there would be a considerable risk of the lake becoming exhausted if the consumption were not proportionately restricted."

The Commission then discussed the system of distribution, but this need not detain me. On the general subject of the water-supply of Bombay they expressed themselves thus:—

"The Commission venture to express their conviction that no scheme, involving any considerable outlay should be adopted by the Municipality, or sanctioned by Government, unless it combines the least possible engineering risk in the method of its construction, with a capability of inexpensive extension from time to time to meet the growing wants of the population. By the last census the inhabitants of the Town and Island of Bombay numbered 816,562;* and it is reasonable to suppose that, in the course of the next 20 or 30 years, this number will be considerably augmented. In the construction of new and costly water works, the future as well as the present wants of the city shall be borne in mind."

And they concluded their report in these important terms:—

While it is the opinion of the Commission that by greater economy of distribution, and the addition of the Toolsee water, much will be done to alleviate the evils of the present scanty water supply of Bombay, it is no less their conviction that no time should be lost in securing a full and permanently reliable supply of water to the town. Even with the addition of Toolsee, the supply from Vehar will be sufficient only for an intermittent service, a *minimum* supply for domestic uses, and an unreliable supply in case of fires. The recommendations of the Commission, therefore, so far as they have gone, point only to temporary measures of relief. A continuous service, at full pressure, is what is required for Bombay, and Bombay should be satisfied with nothing less. This, the Commission consider, will be most securely obtained by a low level reservoir, from which the water should be brought by a covered masonry conduit to Bombay; † and they recommend that surveys should be made without delay with a view to carrying out this proposal. With such a reservoir not only could the supply of water to Bombay be made to keep ahead of

* The census taken last year (1871) shows the population to be as nearly as possible 650,000.

† Further on the reader will observe that I have not failed to bear in mind the opinion of the commission on this point. The Kamun scheme, which involves a low-lying reservoir and a masonry conduit, has been specially investigated to ascertain the advisability and expense of carrying out a project of this class.

any possible increase of the population, but all the water not required for Bombay might be made available for the service of towns on the road, for the supply of the railways, and for irrigation. In this point of view, the work might fairly be regarded as an Imperial work, and not one of a merely local Municipal character."

With the Report of the Commission before them, the Government passed a Resolution on the 31st March, 1870, and on the particular projects proposed by Mr. Aitken they expressed themselves thus :—

"Government concur with the Commission, in rejecting the Shewla scheme. It does not appear to have been ascertained beyond a doubt, that as good a storage basin cannot be found in closer proximity to Bombay, nor are the details of the scheme sufficiently well considered. The amount of the outlay involved also puts it beyond the power of the Municipality for the present at least.

"The Kennery and Poway schemes would not give results commensurate with the outlay they would involve, and the construction of either would only be a half measure.

"A very substantial addition to the Vehar Lake, at an expenditure which is within the means of the Municipality, might, however, be made by the execution of the Toolsee scheme, and Government concur with the Commission that this would be the best practical arrangement."

And on the general question of water-supply they went on immediately after to say :—

"It (the Toolsee scheme) could only, however, be regarded as an *interim* expedient, for it does not provide for the full quantity (fifteen gallons) of water per head for the number of people that now probably inhabit Bombay; and would, therefore, year by year, as the population increases, become more and more inadequate: many years would, however, probably elapse before any practical inconvenience would be felt, and it is reasonable to suppose, in that interval, not only will some suitable scheme for a substantial increase be devised, but that means will be forthcoming for carrying it out.

"It is quite clear that, as a permanent arrangement this city should not be left to depend on one source of supply, liable to suffer from insufficient rain-fall in successive years, or destruction from accident, to the impounding dams.

"The risk of either contingency may not be great, but it does, no

doubt, exist, and, therefore, the Municipality should lose no time in having the further investigation suggested by the Commission made, in view to the selection of a suitable site for another reservoir, so that all may be ready for action as soon as suitable means can be made available; in the meantime the dams of the Vehar Lake should be strengthened, as recommended, and the question of another main from Vehar should be seriously considered."

On receipt of this Government Resolution, the Municipal Commissioner took action by having a careful survey made of the Toolsee valley. When I arrived in Bombay in June 1870, this survey was finished,* and I was directed to submit the Toolsee project as soon as possible. Accordingly in July the plans and estimates were ready, and the Bench of Justices then appointed a Committee composed of the following gentlemen to report on the scheme; Major-Genl. Tremenheere, R.E.; Mr. Ormiston, C.E.; Mr. LeMesurier, C.E.; and Dr. Lyon. According to the Committee's request, I drew up a brief memorandum on the subject, but feeling that so short an investigation as one occupying me six weeks only did not justify my speaking with the least authority on so great a subject, I wrote:—

"I should preface my remarks by informing the Committee that I feel I am in no way capable of forming an opinion as to whether the Toolsee project, in any shape, is the best which the people of Bombay can adopt."

I went on then to say that the project was merely submitted for them to accept or reject on the facts put before them, and that I could neither condemn nor recommend it, I pointed out then that, as no rain gauge had been kept in the Toolsee valley, it was impossible to say with any degree of certainty what quantity of rain fell there yearly. I showed, however, that such records as there were even on the question of the rainfall at Vehar were utterly unreliable; that, while it had always been supposed that the rainfall at Vehar was considerably in excess of that at Bombay, the records threw doubt even on this conclusion; that under these circumstances I preferred to assume that the rainfall was what Mr. Conybeare and Mr. Aitken had assumed it to be—viz., 102 inches, or 8½ feet per annum. To this I added 12 inches, or about 12 per cent., to obtain the rainfall at Toolsee, which was thus calculated to be 9½ feet. I rea-

* I find now that the levels of all the dams which were referred by the Surveyor, Mr. Preston, to the supposed levels of the Vehar Lake, are wrong by nearly fifteen feet. The correct levels are given in the accompanying drawings, *Plates XXIX. and XXX.*

sioned thus: the rainfall at Bombay is 75 inches, and the rainfall at Vihar (102 inches) is 36 per cent. in excess of it. But Toolsee lies as much (200 feet) above Vihar as Vihar lies above Bombay. Now it is an indisputable fact that in the Concan the higher the position, the greater is the rainfall. Thus then if the rainfall at Vihar is 36 per cent. above that of Bombay, the rainfall at Toolsee should most certainly exceed that at Vihar. I assumed this excess to amount to only 12 per cent. on the Vihar rainfall,* and I therefore took the total rainfall at Toolsee to be $9\frac{1}{2}$ feet.

The area of the Toolsee gathering ground, exclusive of that of the lake, which is 214 acres, is 1,233 acres.† Assuming the evaporation on the lake to amount to five feet per annum, I put the following fact before the Committee:—

		Gallons.
On the supposition of the rainfall at Toolsee being 12 per cent. in excess of that at Vihar and $\frac{7}{10}$ ths of total rainfall being collected on the gathering ground.	Quantity collected from over surface of lake,	262,176,750
	Do. from gathering ground,	2,551,132,800
	Total Gallons, ..	2,813,309,550
On the supposition of the rainfall at Toolsee being 12 per cent. in excess of that at Vihar, and $\frac{7}{10}$ ths of total rainfall being collected on the gathering ground.	Quantity collected from over surface of lake,	262,176,750
	Do. from gathering ground,	2,232,300,262
	Total Gallons, ..	2,494,477,012

The water was proposed to be brought to Bombay through an iron pipe under the pressure. In the former case the pipe was to be 30 inches in diameter, and the main dam 96 feet high, while the cost of the works was estimated at 36 lakhs. In the latter case, the pipe was to be 27 inches in diameter, and the dam 87 feet high, while the cost of the project was reckoned at $23\frac{1}{2}$ lakhs.

The Committee appointed by the Bench came to the conclusion that not more than four gallons per diem per head of the population could be obtained from the Toolsee valley, and they estimated the cost of the works.

* The observations taken in 1870 showed the rainfall in the Toolsee valley to be almost exactly 30 per cent. in excess of that at Vihar, but I am not inclined to place much reliance on the observations of a single year. The monsoon of 1871 failed, but the rainfall in Toolsee, 53 inches, was 40 per cent. in excess of that at Vihar, 39 inches.

† The capacity of the lake is given on *Plate XXIX*. For information regarding the dams, *vide Plate XXX*.





to secure this supply at 25 lakhs. On the general question of water-supply they expressed themselves thus :—

“ We are of opinion that Toolsee should not be undertaken unless it be shown conclusively that no better scheme is practicable. This has not been one yet ; and we therefore recommend that in the first place the Kennery scheme be carefully worked out as soon as possible. To do this it will be necessary to have an accurate contoured survey of the valley, and a survey and section of the line of main into Bombay. If while this is in progress, Captain Tulloch can find another site more favorable, he should report on it.”

Acting on the spirit of the Committee's recommendations, I at once began an examination of the surrounding country, and a series of surveys of such valleys as I thought most suitable to the purposes of the town ; but, just as the work was drawing to a close, and while I was engaged in preparing this Report, a sudden and severe illness, contracted while prosecuting my out-door duties, compelled my immediate departure to England on the 14th October, 1871. Shortly after this, and in consequence of the failure of the monsoon, the question of water-supply assumed great prominence, and in November my successor in the office of Executive Engineer to the Municipality, Mr. Rienzi Walton, was called upon to submit another report on the capabilities of the Toolsee Valley. This report, with plans, was ready by the end of December.*

Mr. Walton was of opinion that about 1,340,000,000 gallons yearly, or 3,670,000 gallons daily could be obtained for use. This would be equivalent to $4\frac{1}{2}$ gallons per head per diem during a twelve month for the supposed population at that time—viz., 850,000, but equal to rather more than $5\frac{1}{2}$ gallons per head per diem per annum for the recently ascertained population—viz., 650,000.

In his first project Mr. Walton did not propose to impound any water for use in the Toolsee Valley, but to throw the entire available supply into the Vihar Lake. A dam 35 feet high was to be built across the Toolsee stream, and the water was to be led from the small reservoir thus formed into the Vihar Lake, by a tunnel under the dividing ridge between the two valleys. This tunnel was to be 10 feet wide and 7 feet high, and to have a slope of 20 feet per mile. Mr. Walton was careful to remind the public that only in the event of the lake being sufficiently low to admit of

* *Vide Professional Papers on Indian Engineering, Second Series, Vol. 1., page 320, No. XXXII.*

its holding the extra quantity of water could the latter be made available. In any other case, the water must necessarily, after flowing into the lake, run to waste over the weir.

In his second project Mr. Walton proposed to impound water to such a height (64 feet) as to utilize the ridge of hills between Vehar and Toolsee as a waste weir, so that the surplus water, after the new reservoir became full, might pass into the Vehar Lake. The capacity of the new reservoir was ascertained to be 581,000,000 gallons, or say 2½ gallons per head per diem for one year for a population of 650,000. If the Vehar Lake happened to be full, the surplus water was to be temporarily dammed up on the ridge, and passed over a weir near the Toolsee Dam.

No. 3 Project differed "from No. 2 only in having higher dams, and consequently increased storage." The dam was to be 74 feet high, and the capacity of the lake 1,451,000,000 gallons, equivalent to, say, six gallons, per head per diem for 650,000 people for one year. In this case a dam 21 feet high was proposed on the ridge between Toolsee and Vehar. The arrangements for drawing off the surplus water were similar in their nature to those proposed in No. 2 Project.

Mr. Walton estimated the cost of the different Projects at, No. 1, Rs. 1,38,315—No. 2, Rs. 1,75,221—No. 3, Rs. 3,59,153. He strongly recommended the last, and showed its great superiority to the other two. This project, with some slight modifications proposed by Mr. Ormiston, was approved by the Bench, and an application was made to Government for five lakhs of rupees—the sum which Mr. Ormiston estimated the works would cost. The Government offered the Bench four lakhs only. Some correspondence passed on the subject, but the ultimate result was that the season was too far advanced to admit of much work being done till after the monsoon.

The reader having now been made acquainted with the main events which have occurred in connection with the water-supply of Bombay during the last quarter of a century, will be in a better position to form a judgment on this most important subject.

H. T.

Correspondence.

To the Editor.

SIR,—On reading Paper LXV. on the Margohi Cement, it has occurred to me to suggest to the gentlemen engaged on this interesting investigation, that their experiments would be much more satisfactory and generally available for comparison, if they adopted a procedure similar to that commonly used at home for such enquiries, so as to throw their results into the same form as the great mass of data already accumulated regarding the cements now in common use, particularly Portland, the most important of any, (*vide* Minutes of Proceedings of the Institution of Civil Engineers, Vols. XXV. and XXXII).

I would also venture to remark that the experiments recorded, pages 18-20 of your February Number, are hardly sufficient to justify the conclusion that the new cement is equal to English Portland; it is quite possible it may be so, but cannot be taken as proved. Only one experiment was, if I understand right, made with each kind of cement, and the method and apparatus described are both very liable to have their results affected by many things, besides the strength of the cements; now with the most perfect apparatus yet devised or used, it is generally only considered safe to generalize from the average of a large number of experiments.

It is not quite clear whether the fracture took place through the mortar in any of the experiments; if the mortar merely separated from the bricks, the results are rather indications of the goodness of the bricks and of the workmanship in putting them together, than of the relative strengths of the cements. I am inclined to think that the results, for Portland at all events, must have been vitiated in some such way, because an ultimate tensile strength per square inch, ten or twelve times as great as that now assigned to a joint made with it, is commonly obtained from it (and indeed insisted upon as a mater of contract) at home; and as the sample under trial is stated to have been "just imported and in good condition," it seems scarcely possible that so great a deterioration should have taken place. The precaution was probably taken of using a mixed sample from different packages, otherwise the variations in quality to which single packages are subject, are sometimes quite sufficient to seriously affect the validity of results obtained from them.

SINGAPORE, }
10th April, 1873. }

W. INNES, CAPT., R.E.

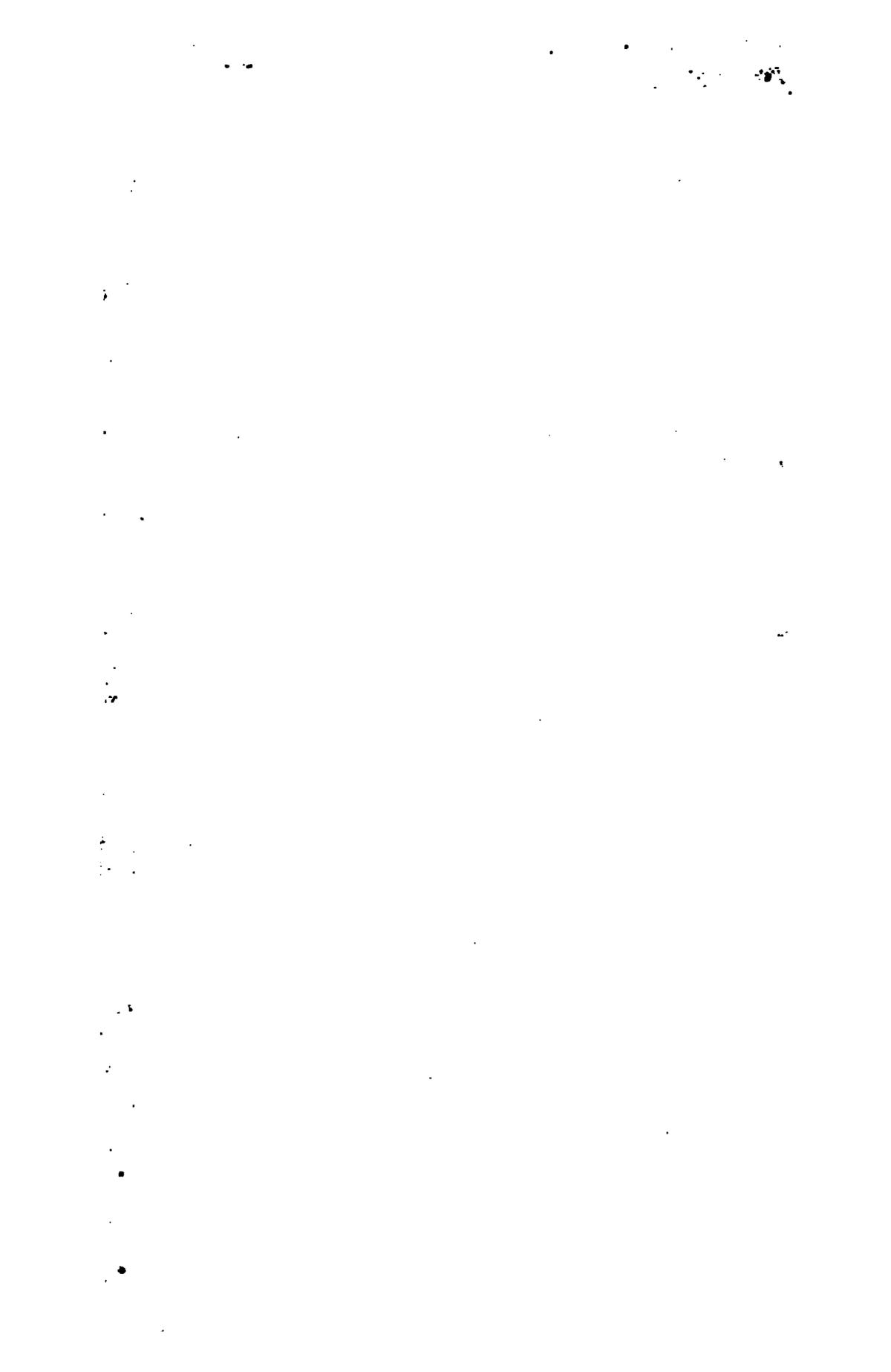



into the Tannah Creek. The area of these three valleys are, roughly speaking, about equal to each other. Each offers us six square miles of gathering ground, so that if we take the rainfall in the Vehar valley as the average rainfall over all, three times the supply which we now obtain from Vehar, or say 25,000,000 gallons per diem, will fairly represent the utmost capabilities of Salsette.

Geologically there is but one formation—trap. Such other strata as may be found on these hills are merely superficial deposits, below which, at a few feet of depth, the same characteristic rock, and generally of a hard, unyielding nature, will invariably be met with.

Thus, then at present we have found two valleys which require to be investigated—the Kennery valley, and the Ewoor valley. The facts of these will be given in full detail hereafter.*

If we leave Salsette and return to Bombay, and then, crossing the harbour, pass on to the mainland, we shall find under our feet a low-lying country with numerous rivers, all flowing westward, and with numerous ranges of hills of varying heights, some connected with each other, others standing by themselves. We shall also find the land steadily rising towards the east, and our progress in the distance threatened by the chain of mountains on which that lovely little sanitarium, Matheran, lies nestled.

Close to the village of Owlch, near Panwell, lies a basin of about eight miles superficial extent, that is, one not much larger than the Vehar valley. As the tide rises above Panwell, it will be clear that a reservoir formed in this locality must necessarily be a low-lying one. In addition to this drawback, there is nothing that can be termed a site for a dam. A search in this direction will be useless.

Leaving Panwell, therefore, and taking a direct course to the east, the first valley which presents itself to us for examination is about four miles off, near the village of Akorlee. In spite of the large gathering ground which it offers, a very cursory glance at its features will satisfy us that it will not answer our purposes. It lies but thirty feet above the sea, so

* I should mention here that it is not my intention to consider the Poway valley, the facts in connection with which were given by Mr. Aitken, in his Report on the water-supply. The scheme has been condemned because there is an unanimous opinion among all the intelligent and educated inhabitants, that no project should be entertained for the construction of a reservoir, the safety of which is at all dependent on the safety of Vehar. Poway lies immediately below two of the Vehar dams, and if anything happened to the latter, there would be very little left of the Poway reservoir. On the same ground the lower portion of the Marole (i. e., the Vehar) valley has not been investigated by me, nor is it, indeed, at all suited to our purposes.

that this lake also would be at a low level. Here too there is no good site for a dam, which, if erected, would require to be two miles long, and would cost an enormous sum of money. Let us try the valley higher up.

About five miles to the east of Akorlee, near the village of Gadheh, the valley begins to contract. In travelling up the stream, moreover, we have risen a hundred and thirty feet, so that while before we were standing on ground only thirty feet above the sea, now we are one hundred and sixty feet above that level. But we have lost nearly two-thirds of our former gathering ground, for whereas the valley above the village of Akorlee has an area of forty-five miles, above Gadheh it has only fifteen. Near Gadheh itself there is no good site for a reservoir. A dam 80 feet high would be a mile and a quarter long, and one a hundred feet high would be nearly two miles long. About half a mile further up the river, near Dhamnee a lake might be formed, *vide Plate XXXI*. But now the gathering ground is still further reduced from fifteen to ten square miles. This objection may be got over in the minds of some, on the consideration that the rainfall in this region is tremendous, and that these ten miles of collecting area would be really equivalent to forty or fifty miles anywhere else. On the other hand, others may urge that the heavy fall of three hundred inches yearly at Matheran is confined to the plateau itself, the area of which is trifling, and that the rainfall in the valleys is probably the same as that in other similar localities. Be this, however, as it may, there is unfortunately no storage capacity at Dhamnee for a large body of water. The streams run through gorges and have rapid falls—falls of from seventy-five to nearly a hundred feet per mile! Even a dam 170 feet high would not send the water back more than about two miles, and this only in the main streams. In fact, a dam higher than the highest* in the world, and five times longer, would not give us a lake of greater superficial extent perhaps than that of Vehar. Thus, although there may be abundance of water available for our purposes, and at a fair height above Bombay. Still the physical features of the country do not admit of its being stored, except at an enormous cost, nor, as will be shown presently, of its being brought into Bombay, except at a greater one.

It is no use to follow this valley any higher. The gathering ground rapidly contracts, and all the objections already urged increase. Let us

* The Furens dam, near St. Etienne in France. It is 164 feet high and about 330 feet long. *Vide* No. LXVIII. of Professional Papers on Indian Engineering, Second Series, for fuller information regarding this work. *Vide* also *Fig. 5, Plate VII.* of the above-mentioned Article.

retrace our steps for some two or three miles, and then, proceeding in a south-westerly direction, let us stop at the village of Cheekleh. Before us stands the giant Prubhul pouring his waters down in numerous streams which meet at our very feet, but defying us to intercept them. No dam which we could construct here would be of any use, and higher up the valley we could not manage without two very expensive works. Let us pass through the gap in the range of hills to the south, and continue our search eastward.

We now come upon two promising valleys with a combined area of over twenty square miles, and with a great water-supply. These two valleys, in fact, are the main recipients of the floods which fall upon Matheran, and they join their waters together close to the village of Chowk. Here then clearly would be abundance of water for our purposes if we could collect it. Unfortunately, however, the spur on the east is very low, lower even than the dam which would be required. We could not in fact intercept the two rivers after their junction at all. The only plan would be to deal with each river separately. But an attempt to do this even would be at great cost. The accompanying plan, *vide Plate XXXII.*, gives a section of the western valley by itself, the more favorable one of the two, and it will be seen that a dam a hundred feet high would be not only nearly a mile long, but which is really the point to look to regarding all dams, very high for the greater portion of the length. The valley, moreover, rises too rapidly (120 feet in two miles) to admit of the storage of much water, nor does it lie so high above Bombay as could be desired. We should not in fact have sufficient pressure for our purposes.

The eastern valley, with characteristics similar to those of the western one, offers us even still less hope of success.

Thus the hills about Matheran, in spite of the heavy rains which pour on them, and in spite too of their comparatively short distance from Bombay, do not offer those facilities for water-supply of which the Engineer is in search. There are no flat wide opening valleys, narrowing suddenly into gorges. On the contrary, either the ground from the bottom of the valleys rises on each side with too great a slope to admit of the storage of much water, or the streams have too rapid falls, or there are no very narrow gorges suitable for dams. Nature evidently had not the common place question of the water-supply of Bombay in her mind, when she fashioned these grand old hills into their present picturesque forms.

retra
soutl
us st
whic
whic
valle
pass
searc
W
over
valle
Matl
Chov
posei
east
coulc
only
do tl
XX
able
woul
rega
valle
stors
desir
Tl
one,
Tl
on tl
bay,
in sc
into
valle
of n
narr
plac
ione

No. LXXVIII.

DESCRIPTION OF THE COUNTRY ABOUT BOMBAY
WITH REFERENCE TO THE "BOMBAY WATER-
SUPPLY."[*Vide* Index Map and Plates XXXI to XXXIV.]

BY MAJOR HECTOR TULLOCH, R.E.

Examine a map* of the surrounding country about Bombay, we find a town stands on an island about eight miles long and two miles wide. This island is separated from the mainland by an arm of the sea, forming the harbour, and gradually narrowing into a creek, runs about 25 miles in a northerly direction, and then, suddenly taking a turn to the west, issues into the Indian Ocean near the ancient town of Salsette.

This tortuous creek forms a second island, known to us as Salsette, having an area of over 150 square miles. It presents, moreover, features which, for the purposes of water-supply, have always attracted much attention, and therefore deserve the fullest consideration. The centre portion consists of several ranges of hills, some of an altitude of over fifteen-hundred feet above the sea. Even the valleys between the ranges are at a great height, and have a considerable command of elevation over Bombay. Of these valleys, however, three only are of any practical use for the purposes of so large a town. The southern valley, that known as Vehar, has already been utilized. There are two others; the Kennery valley† which debouches to the north-west, and the Ewoor valley, which, carrying its waters northwards, throws them

* *Index Map.*

† The southern valley which, later on in this Report, I have, at the request of the late Municipal Engineer, Mr. Hope, gone into thoroughly, forms merely the upper portion of the Kennery valley, therefore, comprised in it.



Let us leave Chowk and travel southwards, and this will bring us into a large valley fed with rain from the precipitous heights of the western ghats. Near the village of Khalapore, where the valley narrows to a width of about two miles, would seem to be the most natural site for the dam. A reference to the accompanying plan, *vide Plate XXXII.*, will show how expensive the dam would be. But this is not all. Two more dams would be required to stop up other gaps in the hills, and worse than every other objection is the fact that the valley lies very low, fifty feet below even the Vehar basin. As the pressure from the Vehar Lake is only just sufficient for our purposes, it is manifest that the pressure from a basin so low and so far away as Khalapore would not suffice.

Before leaving this part of the country, and in order to thoroughly convince the reader, in fact to leave no room for doubt in his mind, of the expense and inadvisability of drawing our water-supply from any of the valleys about Matheran, or to the east or south-east of Bombay, I will now point out to him other and insuperable difficulties, which apply without exception to every reservoir that may be formed in this direction.

This part of the country, however promising it may look on account of its proximity to Bombay in a direct line, can only be considered close to us *practically* if the water is conveyed to the town by a direct route. Now let me point out what this would involve. It must involve a tunnel under some part or other of the harbour.* I have not omitted to consider this matter carefully, and, if I had had any hope of overcoming the difficulties of constructing such a tunnel without the risk of its having to be abandoned ultimately, I should have added another to the present projects, and submitted one for the supply of the town from the east or south-east. But let me proceed to explain.

There are two routes we may take across the harbour. The first is from the mainland to Elephanta, and on from Elephanta to Trombay; and the second is from Elephanta to Butcher's Island, and straight across to Mazagon. Along the former route, there would be a tunnel more than $1\frac{1}{2}$ miles, or 7,920 feet long, and it would be under water fifty feet deep. As it would be practically impossible to have a shaft anywhere along the line, it follows that the headings would be 3,960 feet long—that is to say, that from each end we should have to pierce a tunnel of this length, before the two met in the middle. Now suppose the rate at which we could advance

* *Vide* "Index Map."

near Tannah, say from the Toolsee or Ewoor valleys, would necessitate ten miles only of iron pipes, while to bring water from the nearest valleys in the neighbourhood of Panwell would involve us in a cost of from sixteen to twenty miles of pipes.

The route which a high level conduit from the direction of Matheran would have to take, is marked on the Map,* and a reference to it will show that, if this mode of bringing the water to Bombay were adopted, the channel would be no shorter than those from other reservoirs possessing advantages which are not to be found in the valleys about Matheran.

When all these points are considered—the cost and risk of tunnelling under the harbour—the time required to complete such a work—the chance of the tunnel having to be abandoned through unforeseen difficulties arising in its construction—the delays that would take place in repairing the main when it burst—the heavy cost of the pipes—the great pressure of water to which the pipes would be constantly subjected—the indifferent sites for Dams—the want of storage capacity in the basins—and lastly, the length of the channel, if a high level conduit were adopted—the public will perhaps be disposed to agree with me, that, not until it has been proved that we cannot obtain water from elsewhere, should we be justified in attempting to bring it from beyond the harbour.†

I have now run cursorily over nearly all the country lying to the east of Bombay, and to the west of the ghats. I do not think it necessary to enter on the features of the valleys situated to south of the Patalgunga river, because, however favorable a reservoir so far south may be found, still the cost of bringing the water to Bombay, in consequence chiefly of the obstruction which the harbour presents, must be so great, and the risk of failure is so probable, that the public would never entertain a project of this character.

Being close to the railway station of Kurjut, let us travel northwards and stop at Callian, the junction of the two trunk lines of the Great Indian Peninsular Railway. This will be an admirable stand-point of view for a large tract of country. It will be seen that close to this town meet all the rivers from the western ghats, which take their rise in the great extent of country lying between the Tull Ghat to the north, and the Bhore Ghat

* *Vide* "Index Map."

† Should a Birkenhead spring up in the future about Hog Island, the basins near Matheran might then be turned to account for its supply.

to the south—a distance apart of over sixty miles. It is well known that the rainfall along the Western ghats is among the heaviest in the world, and that during the monsoon, the rivers which have their sources in them bring down enormous quantities of water—floods which no engineering works could possibly impound anywhere in the neighbourhood of Callian. No part indeed of the country about Bombay offers so few facilities for the storage of water as this district.

A glance at the Map will show that on the south and on the west are wide plains, and that in the other directions, instead of the ranges of hills which we meet elsewhere, we have merely solitary hills standing apart from each other, as if they had passed a resolution among themselves to give the rivers as wide a berth as possible for their impetuous careers. There are three principal rivers. Let us begin by following the course of the southern one.

It will be seen that the Poona line of the G. I. P. Railway runs along the valley of the Oolas, and, therefore, that to dam up this river anywhere in its course, would simply be tantamount to swamping the railway. This being out of the question, the only point is whether, as the main stream is not suited to them, some of its tributaries might not answer our purposes. The country through which the Posree, the Khansee, the Dhavree, the Chillar and the Meercholee flow, is open to the same objections as that about Matheran. The fact of its being further from Bombay gives still greater force to these objections. In addition to this, these tributaries soon after leaving the ghats flow over ground unsuited to the construction of dams, and continue their courses apparently with a fixed determination not to be so foolish as to be caught passing through a gorge. Thus the large tract of country between the Matheran range and the Western Ghats, well fed as it is with rain, is singularly innocent of any intention to gratify our propensities for storing water.

Leaving this ungrateful district, let us follow the career of the only other tributary of the Oolas. The Bhurvee is fed by two rivers, both of which rise in the Western Ghats. Mr. Aitken, the late Executive Engineer to the Municipality, examined the valleys of these small tributaries, and I think he did wisely in preferring the northern one. It is in fact on this—viz., the Moorbaree, that the site for the Shewla reservoir proposed by him is to be found. So far as their positions with reference to Bombay are concerned, neither river possesses any advantage over the other; but

The Moorbaree runs in a much higher bed. A reference to the Map will show that while near Shewla, the bed of the Moorbaree is 328 feet above Datum (say 228 above Bombay) the bed of the Mohoghur at Tondlee, which is practically about the same distance from Bombay as Shewla, does not rise to more than 260 feet above datum (160 above Bombay). Thus there is a difference of 68 feet to the advantage of the Moorbaree. This command of elevation enables the Engineer to give a better slope to his delivery channel, whether it be a pipe or a conduit, and thus to obtain either a greater discharge of water at the same cost, or an equivalent discharge at a less cost. The valley of the Mohoghur having, however, been investigated, it is my duty to present the facts to the Bench, and the accompanying plan, *vide Plate XXXIII.*, shows the extent of the reservoir, and the height and length of the dam near Tondlee.

It may occur to many, on examining the map, that there are two gorges on the Mohoghur nearer to Bombay than Shewla, and requiring explanation. The first occurs near the village of Mandweh. Here unfortunately the river is 150 feet below the Moorbaree at Shewla, so that, even if the site for the dam were a good one, which it is not, this superior elevation of the Shewla reservoir would more than counterbalance any slight advantage of distance. The other gorge occurs near the village of Mohoghur, where there is an admirable sight for a low dam, as the accompanying plan will show, but the storage capacity is inferior, and the fact, *vide Plate XXXIII.* of the river being still more than a hundred feet below the Moorbaree at Shewla condemns the valley. Taking this part of the country by itself, it is probable that the Shewla is the best reservoir to be found in it.*

The Bench of Justices have already had submitted to them by their former Exec. Engineer, a project for supplying Bombay with water from the Shewla source, and I have already given as full an account of it as seems necessary. I have given the account, moreover, in Mr. Aitken's own words, so that the project might be judged not through what I might say of it, but by the help of the projector himself. My own feelings prompt me to abstain from criticism; but, as I do not recommend the construction of the Shewla reservoir, I must in duty to the Bench state

* The above information regarding the Moorbaree and Mohoghur valleys is taken from the survey made under Mr. Aitken.

† *Vide* pages 202 and 203, also *Plates XXV.* and *XXVI.* of No. LXXVII., *Professional Papers on Indian Engineering, Second Series.*

my reasons. In a report professing to treat the question of water supply in considerable detail, it would not indeed be fair to the Justices for me to ignore a scheme prepared after a labor of more than two years, and offering to the town a larger supply than had ever before been proposed.

The reasons then why I do not look favorably on the Shewla reservoir are these. It is badly situated for a high level conduit, the supply from it is not capable of the same amount of extension as another reservoir, which will be proposed further on in this Report—the communications in that part of the country are in a wretched state—and heavy compensation would have to be given for the several square miles of most valuable land which would be submerged by the lake.

It would be out of place for me here to point out that the Shewla reservoir does not well admit of a high level conduit. Before doing so, it is necessary I should prove that a conduit is preferable to a pipe. I have discussed this question at length,* and tried to show the great advantages which the former possesses over the latter, with regard to both cost and durability. If I have succeeded in establishing my point, it will no doubt be admitted that, *ceteris paribus*, that is the best reservoir which offers us a high level duct for the greater portion of the distance to Bombay.

Regarding also the important point of the capability of extension, there is no comparison between the Shewla reservoir, and the one submitted in this Report. It would not be possible to carry the Shewla dam above ninety feet, for the water would escape in several directions. The limit, therefore, to the capacity of the lake is the quantity of water contained in the reservoir up to this level, but the capacity of the other reservoir is limited only by the consideration of how high a Dam it is possible to build without running the risk of its crushing in by its own weight. The gathering ground, moreover, of the Shewla basin is little more than half that of the other.

The importance of good roads for the conveyance of materials for large works can hardly be magnified. There are no roads at all between the railways and Moorbar. The only communications are country tracks and during the monsoon, or for four months in the year, the rivers are in flood,

* *Vide* No. LXXVI., Professional Papers of Indian Engineering, Second Series.

Section of the Mohoghur Valley near Mohoghur.

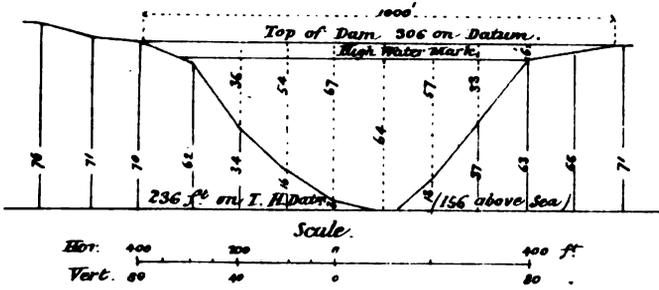

PLAN OF TONDLEE RESERVOIR.

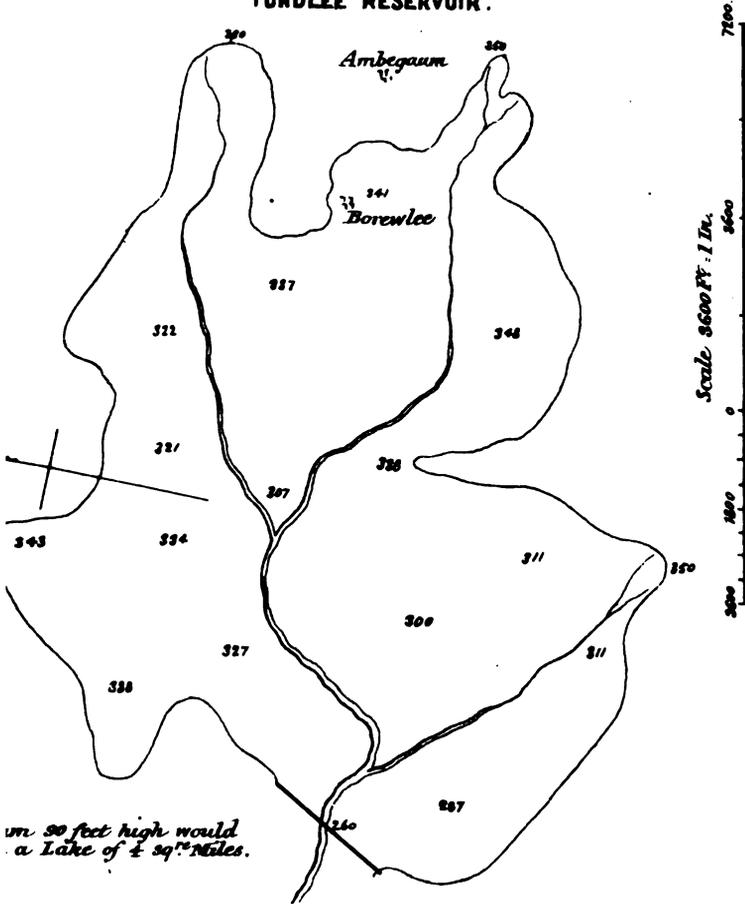

Section of the Mohoghur Valley near Tondlee.

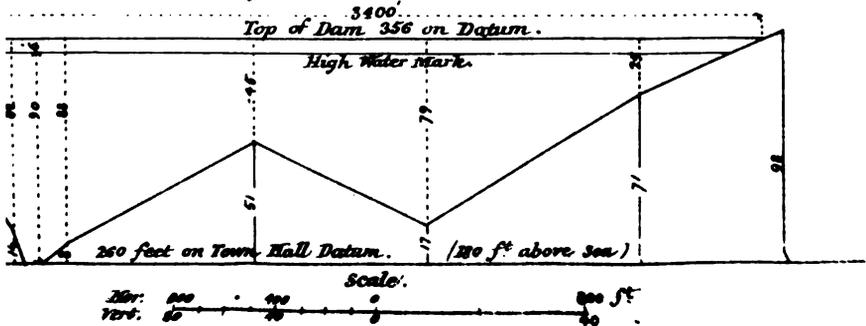



and the part of the country about Shewla is altogether cut off from Bombay. In the other case the reservoir would be but three miles, and the dam but five from the railway, and there is a metalled road running close along the greater portion of the proposed channel.

Nearly the entire area of the land which would have to be taken up for the Shewla Lake consists of the best paddy fields, yielding in this locality large returns to the villagers. To buy land of this class would cost three or four times as much as to buy ordinary jungle, of which practically the whole of the waterspread of the lake I propose would consist.

These points—the practicability of a high level duct, the capability of the extension of the supply, the necessity of good roads, and the cost of the land,—will be gone into more fully with reference to the Shewla Lake, when I explain in detail the characteristics of the reservoir I propose for a large scheme.

Before leaving this part of the country, I think it as well to dispose of the river Kalloo, which lies to the north of Shewla. It will be seen that the area which drains into it is a very extensive one, and that the river has numerous tributaries all rising in the Western Ghats. To dam the course of the main stream anywhere between its junction with the Bhatas in the neighbourhood of Callian, and the point near the village of Kinowlee, where its largest tributaries meet in conflict, would be altogether out of the question. The works would have to be on a gigantic scale, and the destruction of property would be enormous. In fact the Kalloo itself is utterly unsuited to our purposes, nor indeed do its tributaries offer us any advantages. By reference to the Map, it will be seen that the bed of the southernmost tributary near the village of Nandgaon, which is several miles further away than Shewla from Bombay, lies more than twenty feet below the bed of the Moorbaree, at the spot which Mr. Aitken selected for his reservoir. In addition to this, there are no extraordinarily good sites for dams on any of the tributaries to compensate for their greater distance from Bombay. Knowing in fact that there is a site for a reservoir at Shewla with a sufficient command of elevation over Bombay, and knowing that to get the same command on any of the tributaries of the Kalloo, must involve the cost of a greater length of channel with no saving in the cost of the dam, it should be clear that any investigation of the country lying beyond Shewla could lead to no practical result.

Having now examined all that tract which lies south of the latitude of

Callian, let us return to this starting point. The valleys which remain to be gone over are those to the north of Salsette, besides that of the Bhatsa, and that of the Tansa. We will take them, too, in this order.

Leaving Callian, the first valley we come to is that in which the important town of Bhewndy stands, but it is utterly hopeless to make any use of it. There is no good site for a dam, as one, 60 feet high only, *vide Plate XXXIV.*, would be nearly two miles long, and the compensation for the valuable property that would be destroyed, if the construction of a reservoir were attempted, would be ruinous. Let us pass on to the next.

The Lakewlee valley offers us a better prospect. It is thinly populated, it has an area of more than twenty miles, it is surrounded by high hills on which the rainfall must be considerable, the rocky well-worn beds of the stream support the inference of heavy floods, and, although no remarkably good site for a dam is to be found, still there are sites which might answer. Its proximity to Bombay is another advantage. What detracts, however, considerably from its position is that it lies low. The tide rises from the Tannah creek nearly up to the site of the dam, so that it would be impossible without raising the water by artificial means, either at Lakewlee, or at Bombay, or at some intermediate point to supply the town. A survey of the valley has been made, *vide Plate XXXIV.*, but it is not my intention to submit a project for bringing water from this source, simply because there is another basin possessing all the advantages of the Lakewlee one, besides offering us a better site for a dam, and being practically nearer to Bombay.

The Kamun valley, lying at the foot of the Toongar hills, and receiving nearly all the rain which falls in such abundance on their western slopes, has an area of about twenty square miles. A dam impounding only 80 feet depth of water, would give us a waterspread about two and a half times the extent of the Vehar Lake. But like Lakewlee, the Kamun Valley unfortunately lies low, for the tide washes the bed of the river at the very site of the dam. The Kamun water, therefore, would also require to be pumped before it could be made available to the town. The great advantage of the Kamun over the Lakewlee valley lies in the fact that the obstacle of the Tannah creek can be overcome on much more favorable terms in the one case than in the other. To bring the Lakewlee water

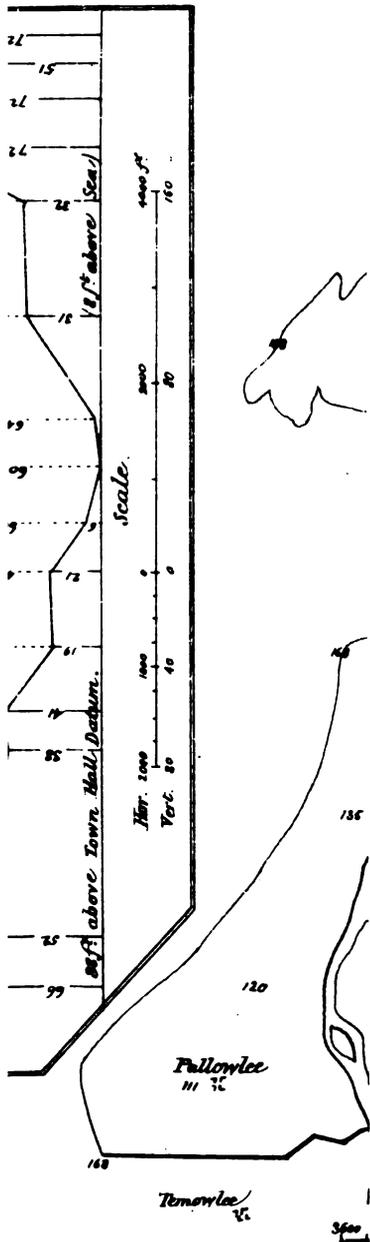

Lon

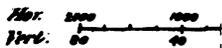
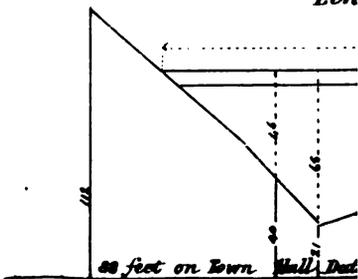

227

er is
reas
ak is
rock.
s the
ublic
ty of
duty
d full
aring

kind,
has a
d it is
ience,
rth of
, and

on the
o dam
partly
wn to
, does
it will
age of
mbay.
reser-
vation
l, but
r high
eyond
e only

amer-
r supply
nearing,

Calli
to be
Bhat
order
Le
porta
use c
vide .
tion 1
of a
next.

Th
it has
on wl
the st
ably .
answe
howe
from
be in
Lake
town.
is no
sourc
of the
pract

Th
nearl
has a
depth
the e
fortun
site o
pump
tage
obsta
terms

into Bombay, the creek must be crossed at a point where the river is three-quarters of a mile broad and where the banks are swampy, whereas in the other case the channel would cross at a point where the creek is only five hundred yards wide, and where there is nothing but solid rock. These considerations have convinced me that the Kamun valley is the best *low level* basin for Bombay, and, as it is necessary that the public should judge for themselves as to the advisability or inadvisability of carrying out a scheme involving pumping,* I have considered it my duty to put one before them. Further on, therefore, the reader will find full details of the "Kamun Project," and have the opportunity of comparing it with projects of another class.

Beyond Kamun there remains yet another valley of the same kind, named Southolee, but it cannot compare with the former. It has a smaller gathering ground, not nearly so good a site for a dam, and it is farther from Bombay. I should be merely taxing the reader's patience, therefore, to dwell longer on it.

We have now passed over all the country lying to the direct north of Salsette. Let us again return to our old starting point, Callian, and follow the course of the Bhatsa.

Between its junction with the Kalloo and the village of Shapore on the Jubbulpore line of the G. I. P. Railway it would be impracticable to dam the Bhatsa, partly because the railway would be submerged, and partly because the works would be far too gigantic and expensive for the town to undertake. However not even at Shapore, nor in its neighbourhood, does the Bhatsa offer any peculiar advantages. By reference to the Map, it will be seen that the bed of this river to the east of Shapore, at the village of Sappaon is 178 feet only above datum, or about 78 feet above Bombay. This is not nearly a sufficient command of elevation for a distant reservoir, and, as will be pointed out presently, not nearly so great an elevation as may be obtained in another basin in the same neighbourhood, but lying practically nearer to Bombay. In fact, to obtain a sufficiently high reservoir on the Bhatsa, we should have to travel many miles beyond Shapore, and to no practical purpose. Let us, instead, examine the only other valley which now remains for consideration.

The Tansa is remarkable as being the only one among all the numer-

* This class of project was specially recommended by the Commission on the Water supply which sat in 1869. *Vide* page 210, of No. LXXVII, Professional Papers on Indian Engineering, Second Series.

ous large rivers discharging their waters into the sea north and south Bombay, which does not rise in the Western Ghats. It has its source in the high hills about Khurdee and Atgaon, which rise to an elevation fifteen hundred and two thousand feet above the sea. It has several tributaries, but these are all too small for our purposes. The only valley worth even a passing remark, is the one in which the village of Kamballah stands, but it lies much too low for a distant basin, and there are gaps among the hills on the margin which would require to be closed. The lower portion, too, of the Tansa itself requires no consideration. It is the upper part which arrests our attention.

It would, indeed, have been strange if the bed of this river along its upper course had not been at a considerable elevation, but this point was soon set at rest. A line of levels carried from Bombay at once proved my inference to be correct. Not far from the village of Kandgaon the bed turned out to be 420 feet above datum, or 320 above Bombay, and even a few miles lower down, near the village of Bhowsa, the bed was 300 feet above datum, or 200 above Bombay. Here, therefore, if a site for a dam and good storage capacity for a reservoir could be obtained, there was sufficient command of elevation for all practical purposes. A persevering search through dense forests rewarded our efforts. A remarkably favorable site for a dam was obtained, and a careful survey satisfied me that an enormous quantity of water could be impounded. The gathering grounds, moreover, proved to be far more extensive than, in fact nearly double, that which any other reservoir within the same distance from Bombay possessed. But of greater importance than any of these advantages was the additional one of the practicability of conveying the water to Bombay for the greater portion of the distance at a high level, in a conduit, and of thus effecting a large saving in the cost of iron pipes which, if adopted in any water supply project, must, do what we may, form the heaviest item of expense. From the Tansa reservoir it would be even an easy matter to throw water into the Vehar Lake, and thus, if found advisable in the future, though it need not be done at first, the Vehar Lake could be always kept full, so that a failure in the monsoon should be no matter of anxiety to the town.*

I have now, in as few words as possible, given a general account of all the country about Bombay with reference to its capability of supplying

* The importance of this should be manifest to every thinking man.

the town with water, and the practical conclusions to which I have arrived are these:—

1st.—That the nearest valleys to Bombay demanding further investigation are those of Kennery, which includes Toolsee and Ewoor, situated in Salsette; that these valleys, lying at a considerable elevation, offer us the advantage of high pressure, but possess the disadvantage of small gathering grounds, and, therefore, of a limited supply of water.

2nd.—That the next nearest basin to Bombay, deserving consideration, is that of Kamun, lying to the north of Salsette. This has the advantage of an extensive gathering ground, but the disadvantage of lying low, which will necessitate the cost of pumping before the supply can be made available to the town.

3rd.—That to obtain abundance of water with high pressure, it is imperative to go some distance from Bombay—that, on the one hand, the Shewla reservoir offers us a large, though limited, supply with ample pressure which the originator of the project, on account of the unsuitability of the line of country to a duct, proposed to render available by a steel pipe under pressure the whole distance to Bombay; that on the other hand, the Tansa reservoir offers us with great command of elevation a practically unlimited supply, which can be brought to Bombay by means chiefly of a high level conduit.

Again I ask the reader to suspend his judgment. At present we are only able to say that these are the best schemes for consideration, but which is the best of them can only be decided after each has been explained in detail. The time for judgment will come when the cost and relative advantages and disadvantages of each project have been given; and in connection with these, the discussions on certain preliminary points, *e. g.*, the form and material suitable for dams, and the relative merits of pipes and conduits, which have been embodied by me in separate Articles,* should be carefully considered.

H. T.

* *Vide Nos. LXVIII. and LXXVI., Professional Papers of Indian Engineering, Second Series.*

No. LXXIX.

THE KENNERLY PROJECT FOR "THE WATER-SUPPLY
TO BOMBAY."[*Vide* Plates XXXV. to XL.]

BY MAJOR HECTOR TULLOCH, R.E.

THE Kennery valley, as will be seen in the accompanying Map of Salsette (*Plate XXXV.*), lies directly north of the Vehar Lake. As it opens to the west, it is better situated to catch the monsoon rains than the Vehar Valley, which is sheltered in this direction by a high range of hills. The most convenient site for the dam—in fact, the only practical one—is a gorge between two hills sloping towards each other. The area of the watershed above this point is $5\frac{1}{2}$ square miles, and the bottom of the gorge is at the level of 203.00 feet on Town Hall Datum, or rather more than 100 feet above Bombay, taking the average level of Bombay at about 100 on datum. Before it can be decided how much water should be stored for use in Kennery, it is manifestly necessary to ascertain the quantity obtainable from the valley. Calculations of this nature are made up of two factors—*1st*, The quantity of water falling in the lake itself; and *2nd*, The quantity not falling on the gathering ground, but flowing off from it. But both these quantities depend on the area of the lake, and this area, again, will depend on the level up to which it is determined to impound water, and the water stored for use will be the quantity contained between this level and that at which the water is drawn off. I will decide the latter point first.

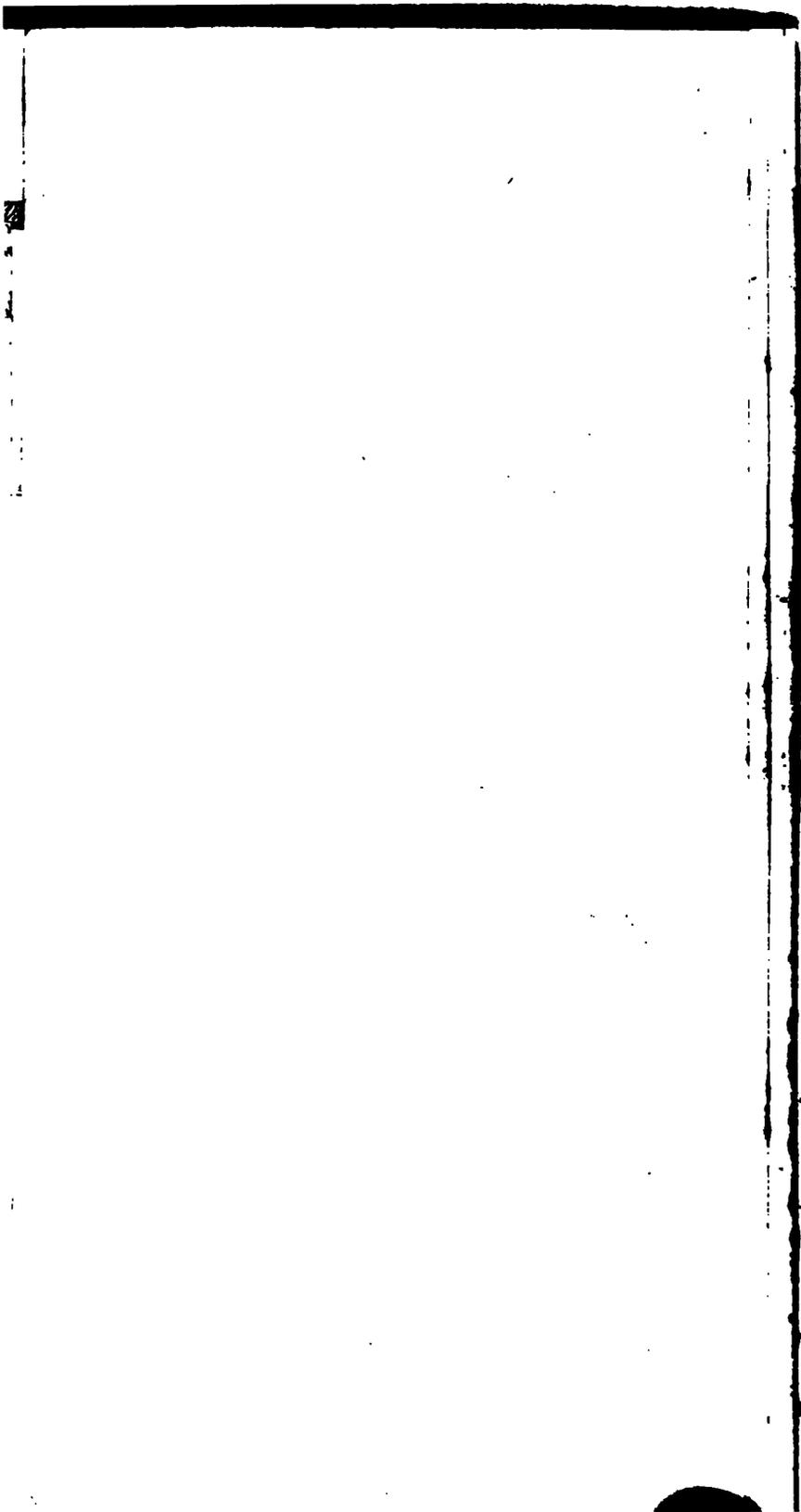



I am of opinion that, whatever may be the capacity of the lake, it would be wise to draw the water at about 270·00 feet above datum, and I fix on this level for a very cogent reason. It would enable us to command the Vehar Lake. In other words, we should be able to throw the Kennery water into the latter whenever it were desirable to do so, which it obviously would be very often. For instance, the Vehar Lake might be comparatively low, while the Kennery reservoir might be overflowing. To have the power, therefore, to save all the surplus supply might be of the greatest importance in the future. Now, the level of the Vehar Lake when full is 262·50 feet on datum, and if, as I propose, the water be drawn from Kennery at 270·00 feet on datum, we shall have a command of $7\frac{1}{2}$ feet. The conduit from Kennery to Vehar would be about two miles long, and, if we gave it a slope of about $2\frac{1}{2}$ feet per mile* (the reason for which will be explained hereafter), it would, on reaching the valley, be about $2\frac{1}{2}$ feet above the lake—a command of elevation which I think it would be wise to retain. I should not personally offer any great objection to the water being drawn from Kennery at 265·00 on datum, which, if the slope of the conduit be reduced to one foot per mile, would allow of its reaching the Vehar Valley with its bottom about six inches above the lake, but I simply think it better not to run things too close. The higher the level at which we draw the water, the higher will be the level at which it reaches the service reservoir, and the greater will be the pressure in the main to Bombay.

I cannot refrain, at the same time, from pointing out that it would be a grave error, in constructing any new reservoirs, if such arrangements were not made as would enable us to run the surplus water into the Vehar Lake. In fact, all future water works for Bombay, while they may be made independent of Vehar, should at the same time be so constructed as to improve the present system by rendering it less liable to failure.

If, then, we say that the water is to be drawn from the Kennery Lake at 270·00 on datum or thereabouts (for a few feet difference will not affect the calculations to follow), the quantities of water which can be stored for use may be seen from the Table on *Plate XXXVI*. The largest lake which it would be possible to form would be one with an area of about 600 acres, involving a dam nearly 180 feet high, while the smallest lake which it would be advisable to form would be one of about 400 acres, with a dam

* The exact slope is 2 feet $7\frac{1}{2}$ inches per mile.

130 feet high. Such a lake, as will be seen presently, will not hold much more than a year's supply.

Assuming 600 acres and 400 acres to be the greatest and least superficial areas of the lake, 102 inches to be the rainfall, 54 inches or $4\frac{1}{2}$ feet the proportion of rainfall flowing off the gathering ground, $2\frac{1}{2}$ feet the evaporation, then the quantity of water obtainable from the Kennery Valley will be as follows:—

	Gallons.
600 acres \times 4,840 square yards \times 9 square feet, \times $8\frac{1}{2}$ feet rainfall \times $6\frac{1}{2}$ gallons in every cubic foot, ..	1,888,475,000
2,920 acres \times 4,840 square yards \times 9 square feet \times $4\frac{1}{2}$ feet rainfall \times $6\frac{1}{2}$ gallons in every cubic foot, ..	3,577,865,000
	4,965,840,000
Deduct for evaporation:—	
600 acres \times 4,840 square yards \times 9 square feet \times $2\frac{1}{2}$ feet evaporation \times $6\frac{1}{2}$ gallons in every cubic foot, ..	408,375,000
	4,557,465,000
Deduct $\frac{1}{3}$ rd for unaccountable waste,	= 1,519,155,000
Total number of gallons yearly,	3,038,310,000*
Quantity when lake is 400 acres in extent:—	
400 \times 4,840 \times 9 \times $8\frac{1}{2}$ \times $6\frac{1}{2}$	= 925,650,000
3,120 \times 4,840 \times 9 \times $4\frac{1}{2}$ \times $6\frac{1}{2}$	= 3,822,390,000
	4,748,040,000
Deduct for evaporation:—	
400 \times 4,840 \times 9 \times $2\frac{1}{2}$ \times $6\frac{1}{2}$	= 272,250,000
	4,475,790,000
Deduct $\frac{1}{3}$ rd for unaccountable waste,	= 1,491,930,000
Total number of gallons yearly,	2,983,860,000

Thus it will be seen that, whether the lake has an area of 600 acres or of 400 acres, does not affect the calculation to any great extent; so that we may assume the total quantity of water obtainable from the Kennery Valley to be about 3,000 million gallons yearly, or say $8\frac{1}{2}$ million gallons daily, or nearly 13 gallons per head per diem for 650,000 people.

* This is the method of calculation proposed by Mr. Ormiston, and I have adopted it throughout this report, because it has been generally accepted. Of course objections may be made to it as no doubt he is aware, but any one who goes into the subject will find it difficult to suggest a better method. The truth is we have no reliable data regarding either the rainfall or evaporation, or the portion of the rainfall which flows off the ground.





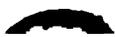

KENNER LONGITUDINA

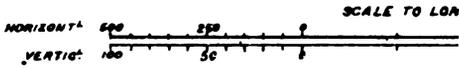
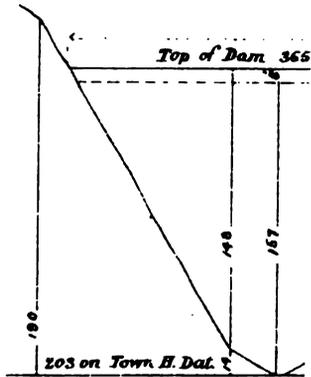

CROSS SECTION.

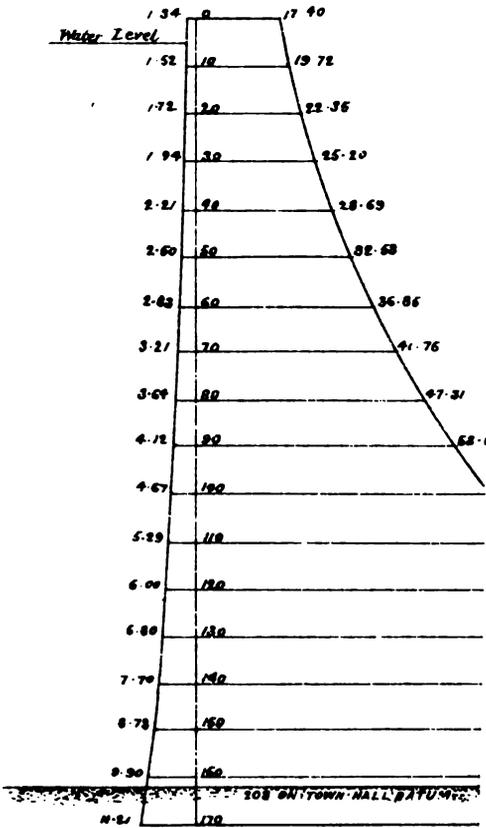

SCALE 1



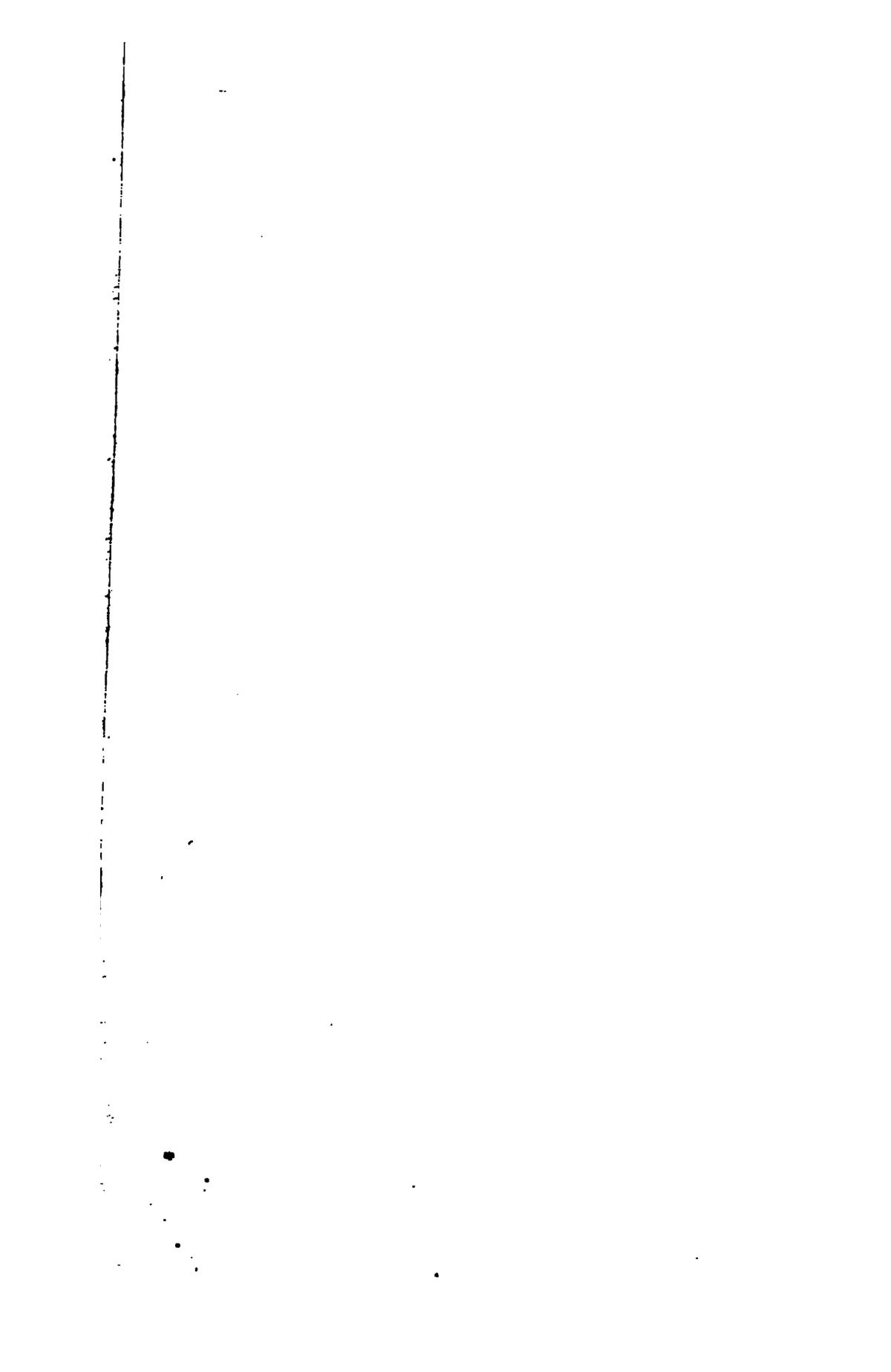

The total quantity obtained from Vehar, according to the same mode of calculation, gives us about 3,600 million gallons yearly (equivalent to nearly 10 million gallons daily), and this is just about as much as is contained in the lake between the average level to which the water rises, and the average level to which it falls yearly.*

The question now is, how much water can we store in Kennery. By reference to the Table on *Plate XXXVI.*, it will be seen that to store 3,000 million gallons, or a one-year's supply obtainable from the valley, the surface of the lake, supposing no water to be drawn for use below 270·00 feet on datum, must be a little below 320·00 on datum. To store a two-years' supply, or 6,000 million gallons, the surface must be at about 345·00 on datum, and to store a three-years' supply, as has been done in the Vehar Lake—or 9,000 million gallons—the surface must be at about 362·00 on datum. The bed of the river at the site of the dam is 203·00 on datum. To get a firm foundation we may not have to excavate more than four or five feet, but it will be safer to say eight feet. Then the bottom of the dam will be at 195·00 on datum, and as the masonry must be carried about five feet above the level of the water, the total height of the dam to impound the different quantities of water will be as follows:—

	Feet.
To impound 3,000 million gallons, or one-year's supply (325·00—195·00),...	130
To impound 6,000 million gallons, or two-years' supply (350·00—195·00),...	155
To impound 9,000 million gallons, or three-years' supply (367·00—195·00),...	172

All the necessary information regarding the dam, if three-years' supply from the valley is impounded, may be found in *Plate XXXVII.*

Having now shown how much water can be obtained from the Kennery Valley, and how it can be stored, the next point for consideration is how to bring it to Bombay.

I propose to do so almost altogether by help of a conduit carried through

* In my Chapter of the History of Water-supply of Bombay, (*vide* page 188, of No. LXXVII., Professional Papers on Indian Engineering, Second Series.) I have already mentioned that the average depth to which the surface falls is about $11\frac{1}{2}$ feet. Now suppose the Vehar Lake is full, the surface will be at 262·50 on datum, and the capacity of the Lake (*vide* page 185 of the above-mentioned Article), will be 10,800 million gallons. Suppose it falls $11\frac{1}{2}$ feet, the surface will then be at 251·00 on datum, and the capacity of the lake about 7,200 million gallons. The quantity that will have been expended in the year, will, therefore, be the difference between 10,800 and 7,200 million gallons, or 3,600 million gallons, which it will be seen, accords with the result obtained by calculation; the quantity lost by evaporation is probably equal to that which is delivered to the town in the four monsoon months while it is raining, when not only is the surface of the lake rising, but the supply to Bombay is going on at the same time. This supply, therefore, is not included in the 3,600 million gallons.

the hills by means of tunnelling. I say almost altogether, because at one part in the line, where the hills are at too low a level for even an aqueduct, we shall be compelled to lay down a syphon. The conduit* would first pass into the Toolsee Valley, then into the Vehar Valley, then under the ridge running along the eastern margin of the lake, then on to the eastern ridge of the Poway Valley, where the syphon would have to be laid, and ultimately into a small service basin, called the Koorla Reservoir, this being the nearest point to Bombay where it is possible to have a high level reservoir at all, and which it is possible to reach from Kennery by conduit. The section of the proposed line of channel is given on *Plate XXXVIII.*, so that it will be seen the idea is easy of accomplishment. There will be only one aqueduct on the line—a small work which I need not further notice.

I have already proposed to draw the water at 270·00 on datum, and to give the first two miles of the conduit a slope of rather more than $2\frac{1}{2}$ feet per mile. I would give the rest of the conduit, $5\frac{1}{2}$ miles long, a slope of one foot per mile, and the syphon, which would be a pipe 48 inches in diameter and three-quarters of a mile long, a slope of 5 feet per mile. The total fall of the conduits and syphon combined would be $14\frac{1}{2}$ feet. Thus, the conduit, leaving the Kennery Lake with its invert at 270·00 on datum, would reach the service reservoir near Koorla at 255·50 on datum, and as the water would be 4 feet deep in the channel, its actual level in the reservoir would be 259·50 on datum, just three feet below the Vehar Lake when full.

From the Kennery Lake to the service reservoir at Koorla, there are, as will be seen on *Plate XXXV.*, two lines of channel to choose from. The one I prefer is that which runs into the Vehar Valley, and continues along the eastern ridge of the Salsette hills. The other line would run along the western slope of the western ridge, but it would be longer. Moreover, in order to reach Koorla, it would have to cross the Vehar and Poway Valleys, and this is an objection to it, inasmuch as if the Vehar dams burst, the Kennery Channel would be carried away. By keeping to the east of the Vehar Lake, the line is much more secure—in fact, almost perfectly so.

Plate XXXIX. gives all the necessary information regarding the Upper Koorla Lake. It will be a small work, and has been designed simply for a service reservoir—i. e., one from which the water can be delivered to Bombay under pressure, and in which a certain quantity of water can be

* *Vide Kennery No. 1 channel line, Plate XXXV.*

OBJECT

I KENN B

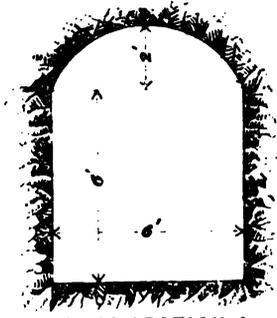

CROSS SECTION A OF CONDUIT

an Inch.
900

v Inch.
900

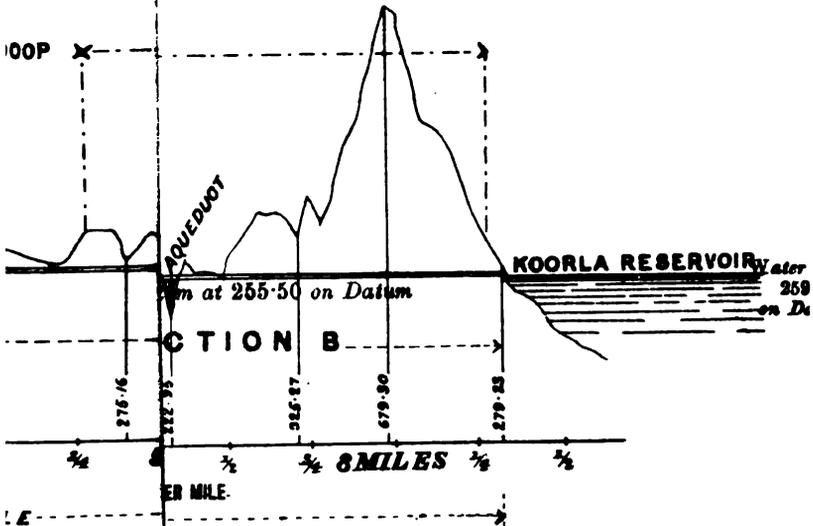

(Sig^d) H. Talloch, Capt^d, R.E.,
Ex. Eng^r Municipality



kept for use in the event of any accident to the channel between Kennery and Koorla. The section of the dam is that proposed by Mr. Rankine for high dams. So strong a work is not absolutely required, and, if the greatest economy is insisted on, the thickness may be reduced throughout, and a saving in the quantity of masonry, amounting to about 25 per cent., may be made.* But, considering the position of the reservoir, I am inclined not to depart from the section given to all the other dams. A very strong dam would be all the more desirable, because it is quite manifest that after some time, a second service reservoir would be required, and it could not be built except below this one, and the water impounded in it would extend up to the proposed dam, which should therefore be made as safe as possible.

I would draw the water from the Koorla Reservoir at 230.00 on datum, so that between this and 259.50 (*vide* Table on *Plate XXXIX.*), we should have a stock of water equivalent to 48 million gallons, or to say nearly a week's supply from the Kennery Basin. Such a reservoir would not entail a dam higher than about 65 feet.

I would, moreover, make the conduit from Kennery for the first two miles 6 feet wide and 6 high, and with as flat an arch as possible. The remaining $5\frac{1}{2}$ miles I would have of much smaller dimensions, with a waterway 5 feet wide and 4 deep. The former portion of the conduit would discharge 57 million gallons daily, and the latter 17. The object of making the conduit so large for the first portion will be seen presently.

The quantity of water obtainable daily from Kennery is, as previously calculated, about $8\frac{1}{4}$ million gallons. The pipe, therefore, from the Koorla Reservoir would have to convey this supply to Bombay. A pipe, 28 inches in diameter and one inch thick, would suffice for the purpose. For a section of the line from Koorla to Bombay, *vide Plate XL.* It is as favorable as could be desired; and as there would be no difficulties of a special kind in laying such a line, no information beyond that given in the *Plate* is needed at my hands. Arrangements would have to be made for drawing the water into the pipe not only from the Koorla Reservoir, but also direct from the Kennery Conduit, so as to secure the greatest head of water possible. As a general rule, the supply would be taken from the conduit, and only when the conduit was under repair would recourse be had to the lake.

* *Vide* para. 22 of Mr. Rankine's Paper. Appendix B. of No. LXVIII., Professional Papers on Indian Engineering, Second Series.

I will now explain the object of making the conduit larger in the upper part of its course. Suppose the Kennery Lake were to be full during the monsoon, and the Vehar Lake were to be in want of a supply, and, instead of letting the Kennery water go to waste over the weir, we brought it to Vehar to fill the latter. The conduit would convey 57 million gallons daily; of this only $8\frac{1}{4}$ would be required to pass on to Koorla for the supply of Bombay; therefore, the remaining $48\frac{3}{4}$ gallons could be flowing into Vehar. It is not necessary to point out the advantage of this.

If the conduit required repair, the town could be supplied from the Koorla reservoir for nearly a week, and, when the repairs were completed, the channel and syphon would bring to Koorla 17 million gallons daily, of which $8\frac{1}{4}$ would travel on to Bombay through the pipe, while the remaining $8\frac{3}{4}$ million gallons could be thrown into the Koorla Reservoir to refill it. In five or six days, therefore, it would be full again and ready for another emergency. If it be considered that a week's supply at Koorla is not sufficient to retain in the service reservoir, another Reservoir, with a dam about 45 feet high, could be built below the first, and it would hold about 130 million gallons, or more than a fortnight's supply from Kennery.* Altogether, therefore, there would be a stock of water for emergencies equivalent to a three-weeks' supply, and during such a period, extensive repairs could be completed to the channel. If the population of Bombay increased considerably beyond its present limits, it would be advisable to connect the Koorla Reservoirs with the Vehar Lake also, so that water might be passed from the latter into the former, and thus Bombay would be further insured against a deficient supply. The water drawn from, in fact lent by, the Vehar Lake for this purpose could be returned to the lake by the channel from Kennery. Thus the Vehar and Kennery projects, although capable of acting independently, would be made at the same time to improve each other.

With regard to the question of purity of supply, it is but necessary for me to say that the hills from which the water would be collected, are all of primitive formation, and that the only possible source of pollution even at present is the village of Toolsee, containing merely a few huts, which can be bought and removed for a trifle. I have no doubt that the Kennery water will prove as pure for all practical purposes as can possibly be desired.

* It could be made to hold a month's supply, if considered desirable, simply by making the dam high enough.

LINE FROM

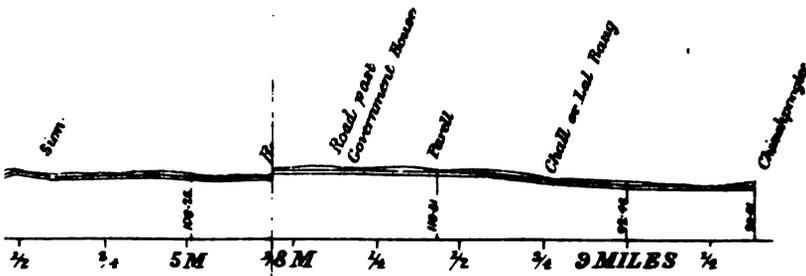

(S^d) H. Lulloch, Capt^r. R.E.,
Ex. Engineer, Manipal



I will explain the arrangement I propose in order to get rid of the waste water from the Kennery Lake, after I have described the Toolsee Project, which is so closely connected with the Kennery Scheme. I will explain the outlet works, which are on the same system for all the reservoirs, when I come to the Tansa Project.

It will be instructive if in this place I compare the salient points of the Kennery Project with the Vehar Scheme. It is obvious at a glance that the Kennery Valley is by no means a favorable one for the storage of water. The Vehar Lake, with a dam 96 feet high, has an area of about 1,400 acres; while the Kennery Lake, with a dam even 170 feet high, would not have an area of more than about 600 acres. The Vehar Lake is a broad expanse of water. The Kennery Lake would be a long narrow basin, but while the Vehar Valley required three dams before water would be impounded in it, one dam only would suffice for the Kennery Valley. In quality the Kennery water would be equal to that of Vehar, as both lakes draw their supply from hills of the same formation.

The cost of the Kennery Scheme with a dam to impound a one, a two, and a three years' supply, would be as follows:—

Estimate No. 1.

COST OF KENNERLY SCHEME.

Dam 130 feet high, and impounding a one-year's supply, 3,000 million gallons, or $8\frac{1}{2}$ million gallons daily:—

	RS.
2 miles of channel, 6 feet high by 6 wide, at Ra. 150,000 per mile,	3,00,000
$5\frac{1}{2}$ ditto, with a waterway 4 feet deep by 5 feet wide, at Ra. 80,000 ditto,*	4,40,000
$\frac{3}{4}$ of a mile of syphon pipe, 48 inches in diameter and 1 inch thick, † weighing 960 tons, at Ra. 160 a ton,	1,58,600
$9\frac{1}{2}$ miles of 28-inch pipe, from Koorla to Bombay, 1 inch thick, ‡ delivering $8\frac{1}{2}$ million gallons daily, and weighing 720 tons per mile, or 6,840 tons, at Ra. 160 a ton,	10,94,400
Carried forward,	19,88,000

* *Vide* (?) note on page 161 of No. LXXVI., Professional Papers on Indian Engineering, Second Series.

† This pipe has to resist a pressure of from 15 to 50 feet only, as it is exceptionally thin, and, therefore, cheap for its size.

‡ The pressure in this pipe will be 160 feet.

	Rs.
Brought forward, ..	19,88,000
Kennerly waste weir,*	2,00,000
Koorla Reservoir, † with its outlet works, and waste weir,	3,00,000
Dam 130 feet high, containing 3,280,800 cubic feet of	
rubble masonry, at Rs. 25 per 100 cubic feet,	8,20,000
Outlet works at Kennerly, tower being 75 feet high, (these	
works will be exceptionally expensive,)	3,00,000
Total, ..	36,08,000
Add 10 per cent. for contingencies, say,	3,60,000
Land,	50,000
Total, ..	40,18,000

Or, say, 40½ lakhs of rupees for 13 gallons per head per diem for the present population.

Estimate No. 2.

Dam 155 feet high and impounding a two-years' supply (6,000 million gallons):—

	RS.
Channel, pipes, waste weir, and Koorla Reservoir, as before	
—viz.,	24,88,000
Dam 155 feet high, containing 5,726,800 cubic feet of rubble	
masonry, at Rs. 25 per 100 cubic feet,	14,31,700
Outlet works, tower being 100 feet high,	3,50,000
Total, ..	42,69,700
Add 10 per cent. for contingencies, say,	4,26,300
Land,	75,000
Total, ..	47,71,000

Or, say, 47¾ lakhs of rupees.

Estimate No. 3.

Dam 172 feet high and impounding a three-years' supply (8,000 million gallons):—

	RS.
Channel, pipes, waste weir, and Koorla Reservoir, as	
before—viz.,	24,88,000
Dam 172 feet high, containing 7,668,000 cubic feet of	
masonry,	19,15,750
Outlet works, tower being 117 feet high,	4,00,000
Total, ..	48,03,750
Add 10 per cent. for contingencies, say,	4,80,250
Land, say,	1,00,000
Total, ..	53,84,000

Or, say, 54 lakhs of rupees.

H. T.

* This will be an expensive work.

† If a thinner section for the dam is insisted upon than that shown in *Plate XXXIX.*, (*vide page 236.*) there will a reduction in this item, amounting to about Rs. 40,000.

No. LXXX.

THE TOOLSEE PROJECT FOR "THE WATER-SUPPLY OF BOMBAY."

BY MAJOR HECTOR TULLOCH, R.E.

THE Toolsee Valley, as may be seen by reference to *Plate XXXV.*, is merely the upper half of the Kennerly Watershed, and is contiguous to Vehar, but lies at a considerable elevation (about 200 feet) above it. As in the case of Kennerly, there is only one site for a dam—a gorge between two hills, where the stream runs over a bed of solid rock. The bed of this stream is at 375·00 on datum, and therefore $112\frac{1}{2}$ feet above the surface of the Vehar Lake, even when the latter is full, and about 275 feet above Bombay. The area of the watershed above the site of the dam is 1,450 acres. In this case, as the entire lake would lie above the Vehar Reservoir, it is not necessary to consider the question of the level at which the water had better be drawn for use. If we drew the water from the very bottom of the lake, we should still be able, if we chose, to throw it into Vehar. The draw-off level should, therefore, be determined

Contours on Datum.	Area of Lake.	Capacity in Gallons.	Contours on Datum.	Area of Lake.	Capacity in Gallons.
475	420	4,532,000,000	430	167	615,000,000
470	385	3,872,000,000	425	125	414,000,000
465	360	3,282,000,000	420	94	263,000,000
460	335	2,752,000,000	415	65	155,000,000
455	310	2,282,000,000	410	39	84,000,000
450	275	1,862,000,000	405	24	41,000,000
445	250	1,492,000,000	395	6	18,000,000
440	234	1,162,000,000	375		Bed of stream.
435	201	866,000,000	370		Bottom of foundation of dam.

on another consideration. What is the lowest level below which the quantity of water stored is too small to be worth drawing for use? The Table* on last page shows the capacities of the Toolsee Lake.

In my report of 1870 on this valley, I proposed to draw the water at 409.90 feet on datum. Mr. Walton has proposed to draw it at 406.00 on datum. The quantity of water in the lake below these levels is not worth consideration, and it is not of any importance which of the two levels is decided upon.

As before, in order to calculate the quantity obtainable from the Toolsee watershed, we must know the area of the lake, and, as in the case of Kennery, I will assume the largest and smallest areas. For reasons to be stated hereafter, I consider the largest lake it would be advisable to form in the Toolsee Valley should be one of about 400 acres; the smallest—that which Mr. Walton recommended, one of about 250 acres. Taking the rainfall and evaporation to be the same as in the case of Kennery, and the area of the watershed at 1,450 acres, the quantities of water from the two lakes will be

Quantity in lake of 400 acres, superficial extent:—

				Gallons:
$400 \times 4,840 \times 9 \times 8\frac{1}{2} \times 6\frac{1}{2}$	= 925,650,000
$1,050 \times 4,840 \times 9 \times 4\frac{1}{2} \times 6\frac{1}{2}$	= 1,286,381,250
				<u>2,212,031,250</u>
Deduct for evaporation:—				
$400 \times 4,840 \times 9 \times 2\frac{1}{2} \times 6\frac{1}{2}$	= 272,250,000
				<u>1,939,781,250</u>
Deduct $\frac{1}{3}$ rd for unaccountable waste,			 646,593,750
Total number of gallons yearly,				<u>1,293,187,500</u>

Quantity in lake of 250 acres, superficial extent:—

$250 \times 4,840 \times 9 \times 8\frac{1}{2} \times 6\frac{1}{2}$	= 578,531,250
$1,200 \times 4,840 \times 9 \times 4\frac{1}{2} \times 6\frac{1}{2}$	= 1,470,150,000
				<u>2,048,681,250</u>
Deduct for evaporation:—				
$250 \times 4,840 \times 9 \times 2\frac{1}{2} \times 6\frac{1}{2}$	= 170,156,250
				<u>1,878,525,000</u>
Deduct $\frac{1}{3}$ rd for unaccountable waste,			 626,175,000
Total number of gallons yearly,				<u>1,252,350,000</u>

* This is prepared partly from Mr. Walton's Report of 1871, and partly from my Report of 1870.

The mean of these two results, or 1,272 millions, is almost exactly what Mr. Ormiston calculated* the supply from Toolsee to be, and this is equivalent to, say, 3½ million gallons daily, or to nearly 5½ gallons per head per diem for a population of 650,000.

A reference to the Table given before will show that to store this supply, the surface of the lake must be at about 442·00 on datum, to store double this quantity (2,544 million gallons), or a two-year's supply, the surface must be at about 457·00 on datum, and to store a three-year's supply, or 3,816 million gallons, the surface must be at about 470·00 on datum.

The bed of the river at the site of the dam is rock, and stands on 375·00 on datum. Let us suppose that we have to cut away five feet of stone to obtain a perfectly satisfactory foundation; the bottom of the dam will then be at 370·00 on datum, and, remembering, as in the case of the Kennery lake, that the top of the dam must be carried five feet above the level of the water, the height of the dam to impound the different quantities of water will be:—

	Feet
To impound 1,272 million gallons, or a one-year's supply (447·00 — 370·00),	77
To impound 2,544 million gallons, or a two-years' supply (462·00 — 370·00),	92
To impound 3,816 million gallons, or a three-years' supply (475·00 — 370·00),	105

The only source of pollution in the Toolsee Valley is the village, which of course would have to be removed. The water would then be as pure as that from Vehar.

As compared with Vehar, it will be seen that Toolsee Valley does not offer us much of a supply, nor would the lake, with a dam as high as the main Vehar Dam, make a waterspread of more than about one-quarter the area of the present lake.

To bring the Toolsee water to Bombay, the cheapest plan would be to lay down a pipe† which, as it need not be more than 21 inches in diameter and three-quarters of an inch thick, would cost less even than a masonry

* *Vide* page 6 of his "*Memoranda as to the Toolsee Scheme.*" He calculated the quantity at 1,908 million gallons without deducting for unaccountable waste, which, on his assumption of ¼rd would reduce the supply to 1,269 million gallons.

† No survey has been made specially to show the line of pipe, but it is hardly necessary for me to say that there will be no difficulty in laying down the line. It should run along the eastern margin of the Vehar Lake and along the eastern ridge of the Poway Valley, and so on to the village of Koorla, from which point it would run as shown in *Plate XL*.

conduit. Another advantage which a pipe in this particular instance would give us, would be that we should be able to supply all the high localities of Bombay under pressure, and without the help of pumps.

Of course, if the Kennery Project were carried out in conjunction with the Toolsee Scheme, it would be absurd to go to the expense of a special iron pipe from Toolsee to Bombay. In such a case the Toolsee water should decidedly be thrown into the channel from Kennery to Koorla, and this could be done at a trifling cost, inasmuch as the channel would pass close to the Toolsee Lake. The conduit and syphon, already proposed for the Kennery Scheme, would be capable of carrying more than this extra quantity of water.

The outlet works, if the two schemes were carried out together, would be of the character to be described when I come to the Tansa Project ; but if the water were drawn by a pipe, they would be of the character proposed by me in 1870, *vile Plate XXX*.

But whether the Toolsee Scheme were carried out by itself or in conjunction with the Kennery Project, I would still arrange the works so as to be able to pass the surplus water at will into either the Vehar or the Kennery Valley, and thus to fill whichever of the lower lakes might happen at the time to be in want of a supply.

If the Kennery Lake were full, I would on no account—not even if the Vehar Lake were full also—pass any water from Toolsee into the Kennery Valley. The surplus water in such a case had far better be thrown into the Vehar Lake. My object in drawing attention to this point is to avoid the expense of a large waste weir in the Kennery Valley which, indeed, is not at all suited to such a work. Now the Vehar Valley admits of the construction of waste weirs to great advantage. There are several spots round the margin of the lake admirably situated for works of this kind, and notably one behind the present Municipal bungalow. Here a large weir could be constructed, to pass off the surplus water from the Toolsee Valley, at a much less cost than one of half the size at Kennery, and the water would escape down a natural stream and cause no damage. At Kennery the water from the waste weir would escape down along the foot of the dam, and it would be well to reduce this quantity of water as much as possible, otherwise special works at considerable cost would have to be carried out to prevent the dam being injured. In fact, I would arrange, so that the Kennery waste weir should

be able to discharge the surplus water from the lower portion only of the valley, and never would I even allow the whole of this quantity to pass over it, as I would carry off as much as possible by the channel and throw it into the Vehar Lake.

—————
Estimate No. 1.

COST OF TOOLSEE SCHEME.

Dam to impound a one-year's supply, 1,272 million gallons, or $3\frac{1}{2}$ million gallons daily :—

	RS.
17 miles of 21-inch pipe, one inch thick, weighing 560 tons per mile, or, 9,520 tons, at Rs. 160 a ton,	15,23,200
Waste Weir,	75,000
No. 1 Dam, 77 feet high, containing 459,700 cubic feet of rubble masonry, at Rs. 25 per 100 cubic feet, ..	1,14,925
No. 2 Dam (<i>vide Plate XX.</i>), will not be required.	
No. 3 Dam, a small work,	70,000
Outlet works, tower being 50 feet high,	1,00,000
	18,83,125
Add 10 per cent. for contingencies, say,	1,88,875
Land, say,	50,000
Total,	21,22,000

Or, say, $21\frac{1}{2}$ lakhs of rupees for $5\frac{1}{2}$ gallons per head per diem for the present population.

Estimate No. 2.

Dam impounding a two-years' supply 2,544 million gallons :—

	RS.
Pipe as before,	15,23,200
Waste weir as before,	75,000
No. 1. Dam, 92 feet high, containing 774,700 cubic feet of rubble masonry at Rs. 25 per 100 cubic feet, ..	1,93,675
No. 2. Dam, an insignificant work,	10,000
No. 3. Dam, containing 1,386,400 cubic feet,	3,46,600
Outlet works, tower being 65 feet high,	1,25,000
	22,78,475
Add 10 per cent. for contingencies, say,	2,27,525
Land, say,	50,000
Total,	25,01,000

Or, say, 25 lakhs of rupees.

Estimate No. 3.

Dam impounding a three-years' supply, 3,816 million gallons :—

	RS.
Pipe as before,	15,23,200
Waste Weir, as before,	75,000
No. 1. Dam, 105 feet high, containing 1,001,600 cubic feet of rubble masonry,	2,50,040
No. 2. Dam, a small work.	70,000
No. 3. Dam, containing 1,911,200 cubic feet of masonry,	4,77,800
Outlet works, tower being nearly 80 feet high,	1,55,000
	<u>25,51,040</u>
Add 10 per cent. for contingencies, say,	2,51,960
Land, say,	50,000
	<u>28,03,000</u>
Total,	

Or, say, 28 lakhs of rupees.

H. T.

No. LXXXI.

THE EWOOR PROJECT FOR "THE WATER-SUPPLY
OF BOMBAY."[*Vide* Plates XLI. to XLIII.]

BY MAJOR HECTOR TULLOCH, R.E.

THE next valley to consider is that of Ewoor, which (*vide Plate XXXV.*) lies to the north of Toolsee, being separated from it by a high range of hills. It is by no means so well suited to the storage of water as either Kennery or Toolsee, and consists of one small and two larger valleys, the latter being divided by a ridge (*vide Plate XLI.*). The upper part of the middle valley is very flat, but there is no site for a dam, and the gathering ground is exceedingly limited, being hardly a square mile in area. There are two practical ways in which a lake might be formed in Ewoor. The first is by damming the streams in each valley separately, the second is by damming the northern stream by itself, and the two southern streams below their point of junction. In the first case, three dams would be required, and, in the second, only two. But to be of any use, the dams must be very high, as will be seen presently. Whether the project of two or that of three dams were adopted, the area of the watershed would not differ to affect our calculations, so that it may be taken at about $4\frac{1}{2}$ square miles, or 2,720 acres. It would not be advisable to draw the water at a lower level than 430.00 on datum, as the capacity of the lake below this point is very small. The area of the largest lake it would be possible to make would be about 900 acres, and the area of the smallest lake it would be advisable to have would be 450 acres.

Taking the rainfall and evaporation to be the same as before, the quantities of water obtainable from the Ewoor Valley in the two cases would be:—

Quantity when area of lake is 900 acres:—

				Gallons.
	$900 \times 4,840 \times 9 \times 8\frac{1}{2} \times 6\frac{1}{2}$	=	2,082,712,500
	$1,820 \times 4,840 \times 9 \times 4\frac{1}{2} \times 6\frac{1}{2}$	=	2,229,727,500
				4,312,440,000
Deduct for evaporation:—				
	$900 \times 4,840 \times 9 \times 2\frac{1}{2} \times 6\frac{1}{2}$	=	612,562,500
				3,699,877,500
	Deduct $\frac{1}{4}$ rd for unaccountable waste,	=	1,233,292,500
				2,466,585,000
Quantity when area of lake is 450 acres:—				
	$450 \times 4,840 \times 9 \times 8\frac{1}{2} \times 6\frac{1}{2}$	=	1,041,356,250
	$2,270 \times 4,840 \times 9 \times 4\frac{1}{2} \times 6\frac{1}{2}$	=	2,781,033,750
				3,822,390,000
Deduct for evaporation:—				
	$450 \times 4,840 \times 9 \times 2\frac{1}{2} \times 6\frac{1}{2}$	=	306,281,250
				3,516,108,750
	Deduct $\frac{1}{4}$ rd for unaccountable waste,	=	1,172,036,250
				2,344,072,500

The difference is not great between the two results, so that we may assume 2,400 million gallons yearly, or say $6\frac{1}{2}$ million gallons daily (equivalent to 10 gallons per head per diem for the present population of 650,000), to be the supply obtainable from the Ewoor Valley.

By reference to the Table on *Plate XLI.*, it will be seen that, to store this quantity, the surface of the lake must be, in the case of the reservoir with two dams at about 460.00 on datum, and, in the case of the reservoir with three dams, at about 464.00 on datum. To store double this quantity (4,800 million gallons), or a two-years' supply, the surface of the lake in the two reservoirs must be at 476.00 and 481.00 on datum, respectively; and, to store three times this quantity (7,200 million gallons), or a three-years' supply, the surface must be at 490.00 and 495.00 on datum.

If we suppose the bottom of the foundation of the dam to be six feet below the bed of the stream, which runs over rock, it will be at 345.00

E W
CONT
E W



<i>Contours on Datum.</i>		<i>Area in Acres.</i>	<i>Capacity in Gallons between the different Contours.</i>	<i>Gallons per head per diem: between the contours for a population of 100,000 for a year.</i>	<i>Total quantity of water in Gallons between the 480 contour / below which the water will not be drawn and the other Contours.</i>	<i>Total number of Gallons per head per diem for a year for a population of 100,000 between the 450 and the other contours.</i>	<i>Contours on Datum.</i>
FOR DAMS 1 & 2.							
530	109	2,702,462,400	7.404	16,826,356,800	46.102	530	
520	967	2,521,252,800	6.908	14,123,834,400	38.698	520	
510	886	2,326,104,000	6.378	11,602,641,600	31.790	510	
500	822	2,082,168,000	5.706	9,276,537,600	25.917	500	
490	788	1,816,680,800	4.976	7,194,369,600	19.712	490	
480	638	1,571,644,800	4.306	5,378,788,800	14.787	480	
470	527	1,296,395,600	3.532	3,807,144,400	10.481	470	
460	468	1,068,091,200	2.926	2,510,798,400	6.879	460	
450	353	850,291,200	2.080	1,442,707,200	3.363	450	
440	265	592,416,000	1.623	582,416,000	1.623	440	
430	170					430	
FOR DAMS 1, 3 & 4.							
530	318	2,984,182,800	6.669	14,982,386,000	40.913	530	
520	870	2,266,120,000	6.206	12,498,235,200	34.249	520	
510	798	2,082,168,000	5.706	10,233,116,200	28.038	510	
500	786	1,892,240,400	5.186	8,150,947,200	22.388	500	
490	683	1,661,796,200	4.526	6,258,700,800	17.149	490	
480	553	1,386,350,400	3.800	4,604,306,400	12.623	480	
470	489	1,122,106,600	3.074	3,218,956,200	8.222	470	
460	364	811,275,200	2.487	2,087,842,600	5.749	460	
450	305	712,641,600	1.953	1,786,674,400	3.252	450	
440	217	472,932,800	1.299	472,932,800	1.299	440	
430	130					430	

(S^d) H. Tulloch, Capt., R.E.
Ex. Eng^r Municipality.



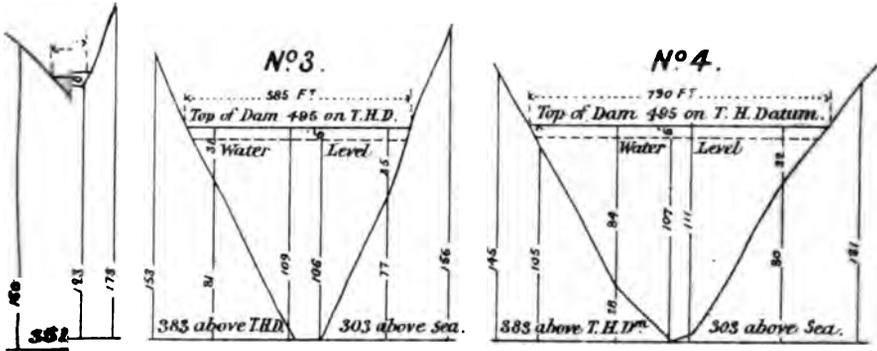

1500 F.
 500 .

Water

Nos 3 & 4.

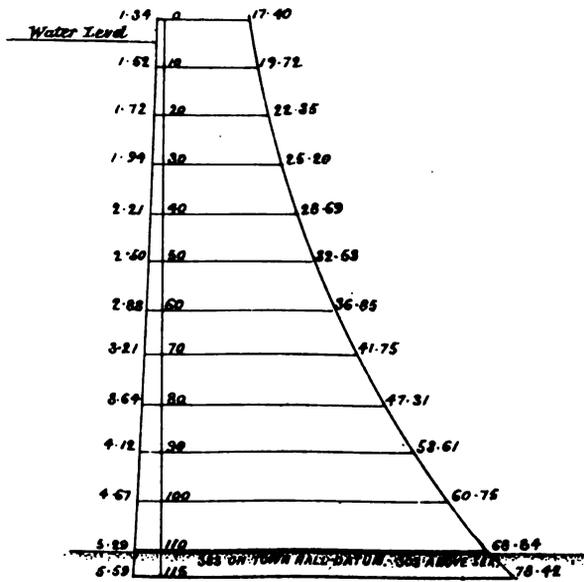

20 F.

(S²) H. Tulloch, Capt. R.E.,
 Ex. Eng^r, Municipality.



on datum, and, if we suppose the masonry to be carried five feet above the surface of the water, the height of the main dam to impound the different quantities of water will be:—

	Reservoir with 2 Dams. Feet.	Reservoir with 3 Dams. Feet.
To impound 2,400 million gallons, or a one-year's supply (465 — 345) and (469 — 345),	120	124
To impound 4,800 million gallons, or a two-years' supply (481 — 345) and (486 — 345),	186	141
To impound 7,200 million gallons, or a three-years' supply (497 — 345) and (500 — 345),	150	155

These dams are not so high as those required to store a one, two, and three years' supply in the Kennerly Valley, but the supply from Kennerly is greater than that from Ewoor in the proportion of 3,000 to 2,400 million gallons yearly, or of 13 to 10 gallons per head per diem for the present population. To compare the heights for the absolute quantities of water stored, the dams in the two valleys, to store 3,000, 6,000, and 9,000 million gallons, would be about the same height—130 feet, say 150 feet, and say 170 feet. All the necessary information regarding the dams is given on *Plate XLII*.

There is a small village, named Ewoor, which would have to be removed in the event of this valley being utilized, and, if this were done, the water would be of the same character as that from the other sources in the sallette.

I would draw the water from the Ewoor Lake by a channel, as the cheapest and best method. If a pipe were adopted, it would require to be 27 inches in diameter and, in order to resist the pressure of nearly 500 feet, 1½ inch thick. Such a pipe would cost about 1½ lakhs of rupees a mile, and would deliver but 6½ million gallons daily; while a channel with a waterway four feet deep by five wide would cost Rs. 90,000 a mile, and would, with a slope of one foot per mile, carry 17 million gallons daily to Koorla.

Plate XXXV. will show the course which the channel would take, and *Plate XLIII*. is a section of the line. The Ewoor Lake lying as it does at a considerable elevation above Vehar, a great slope could be given to the channel. If, for instance, the water were to be drawn at 430.00 on datum, as previously proposed, there would be an available fall for the six miles of channel to Vehar of nearly 170 feet. Such a slope amounts

to more than 28 feet per mile, and a channel of the above dimensions with this fall would discharge more than 90 million gallons daily, but the velocity of the stream would exceed 500 feet per minute, or say 8 feet a second—more than any conduit should, in my opinion, be subjected to.

It will be seen in *Plate XLIII.* that, instead of this great slope, one of only a foot a mile has been given to the channel, and I will explain the reason.

If the Ewoor Project were ever to be carried out, I think the same principles should be borne in mind as, I have endeavored to explain, should guide us in the Kennery Scheme. In describing the latter, I pointed out how important it would be to construct the works, so that they should be independent of Vehar, but still arranged in such a way as to add to the security of the existing supply. And I recommended that the channel from the Kennery Lake should, for the first two miles of its course, have not only a greater slope, but a greater section, in order that, if the Kennery Lake were full, a considerable quantity of the waste water might be passed into the Vehar Lake to get it full also.

Now, with regard to the Ewoor Lake, I have shown that an enormous fall is available for the channel, and that, if we chose, we could, without even enlarging the section, deliver a great quantity of water to Vehar. But I would not recommend this course. It must already be evident to every one that the time will shortly arrive, if it has not done so already, when, in order to add to the water supply of Bombay, we shall be compelled to make a high level reservoir beyond Salsette.* Such a reservoir must have a high level channel along the range of hills lying to the west of Kolset, Tannah, and Bhandoop; and it would be a grave mistake not to construct it at such a level that it should command Vehar. Now, such a channel must follow as nearly as possible the course of the last $9\frac{1}{2}$ miles of the Ewoor Conduit,† shown in *Plate XLIII.* This being the case, and supposing that the Ewoor Project were carried out, then I think it would be very wise to give the portion of the Ewoor channel lying above the Vehar Lake, $5\frac{1}{2}$ miles long, a much larger section than

* I say *high level*, because, as the reader will see further on, the best project, with a low level reservoir—viz., Kamun—cannot compare with projects of the high level reservoir class, either for convenience or cheapness. Under these circumstances, there is not a great probability of such a project being carried out.

† The reader will see the force of all this when he comes to the Tanse Project.

PLATE XLIII.



SECTION OF A

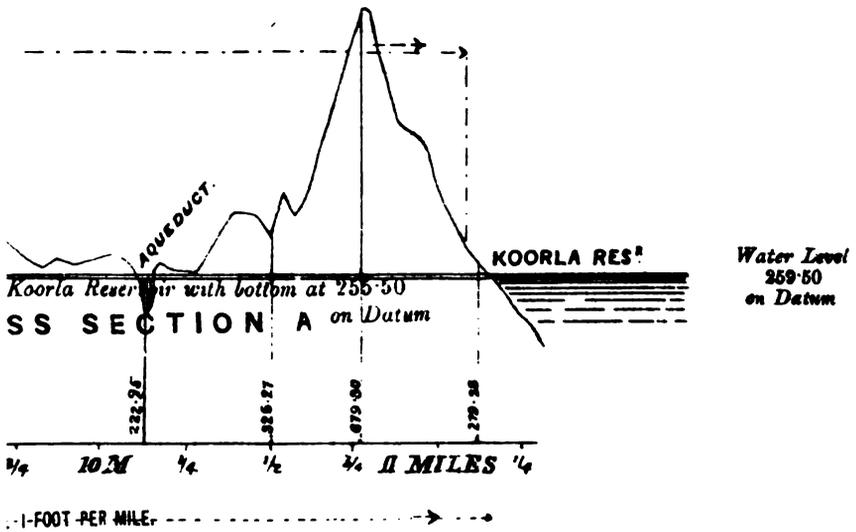

(Sd) H. Tulloch, (ignr. R. E.,
Ex. Engr. Municipality



the rest—a section 6 feet wide by 6 high. Such a channel would discharge 36 million gallons daily. The first $1\frac{1}{2}$ miles of conduit from the Ewoor Lake should have a fall to deliver the same quantity at least into the lower channel. But I should prefer to give it even a greater slope than this—in fact, the greatest slope possible without incurring the risk of the velocity of the water injuring the channel. As we have an excessive slope at our command, it may be convenient, especially as to do so will entail no additional expense, to arrange for drawing as much water as we can from the Ewoor Lake. The greatest velocity which the stream might have is about five or six feet per second, and a channel having a waterway five feet wide and four deep, with the latter velocity would deliver 64 million gallons daily, and would require a slope of 14 feet per mile. As the portion of channel with this slope would not be more than $1\frac{1}{2}$ miles long, the total fall, when it reached the lower level conduit, would be 21 feet, and as the lower conduit at the point of junction with the upper, would be at 268.25 on datum, and the upper conduit, starting from the lake at 430.00, would be at 409.00, the water would have to be dropped, say, 140 feet.

Thus, then, the arrangements which I would make regarding the channel are as follows:—It would leave the Ewoor Lake at 430.00 on datum, with a slope of 14 feet per mile, and a waterway five feet wide by four deep. After running for $1\frac{1}{2}$ miles, it would suddenly drop about 140 feet, and start again on its course at 268.25 on datum, with a slope altered to one foot per mile, and a waterway six feet wide by six deep.

On reaching its point of junction with the Kennery Channel* (near the Vehar Lake) it would be at 262.50 at datum—i. e., exactly the level of the lake when full. From this point it would follow the course of the Kennery channel precisely, and so arrive at the Koorla Reservoir, with its invert at 255.50 on datum, and the level of the water in the Koorla reservoir would be as before—viz., 259.50 on datum, or three feet below the surface of the Vehar Lake.

If the Kennery and Ewoor Projects were carried out conjointly, one conduit from the point of junction of the two channels would suffice, inasmuch as that proposed for either (with a waterway five feet wide by four deep, and with a slope of a foot per mile) would be capable of discharging the supply from both.

* *Vide Plate XXXV.* The point of junction in this *Plate* should be higher by about half a mile.

Now let us see what the effect or working of the proposed arrangements would be.

If the Ewoor Lake were full, and it were considered advisable to throw the surplus water into Vehar, the channel would bring down 36 million gallons daily, and as $6\frac{1}{2}$ millions only would be required for the daily supply to Bombay, the remaining $29\frac{1}{2}$ million gallons could be thrown into the present lake. And when the time came to construct a high level reservoir beyond the island of Salsette, the portion of the Ewoor Channel along the eastern slope of the Tannah range of hills and up to Vehar, a length of five and a quarter miles, would be ready to hand, and would answer for the project perfectly, and without further outlay. If, on the other hand, the channel from the Ewoor to the Vehar Lake were constructed of a smaller size, and, in order to get the same discharge, an uniform slope of twelve feet per mile were given to it, and this could easily be done, then the channel would not work in with, or be of any use to, the future projects. It would be far above the level to which it would be possible to bring the water from any distant reservoir.*

The surplus water which might not be required for Vehar could be passed over a waste weir down into the lower portion of the Ewoor Valley; but as this weir would be of the ordinary kind, it is unnecessary for me to dwell on it.

The outlet works at the Ewoor Lake would be similar in character to those proposed for the Tansa Reservoir, and described further on. Special arrangements of the same kind would also have to be made for dropping the water from the upper into the lower conduit, or this might be effected by letting the water down a series of steps. The hill at the site of the proposed works is exceedingly rocky, and therefore well suited to the purpose.†

The upper Koorla Reservoir would answer just as well for the Ewoor as for the Kennerly Project, and having already described it, nothing further need be said on the subject.

From the Koorla Reservoir a pipe 26 inches in diameter would be required to Bombay, and this should be at least one inch thick. The line along which the pipes would run is shown in *Plate XL*.

* This will be evident to the reader after the description of the Tansa channel.

† Another mode of bringing the water down from the upper into the lower channel would be to erect a turbine or other form of water engine, and to apply the force of the water to some useful purpose. Six and a half million gallons falling through 140 feet would be equivalent to more than 175-horse power.

Estimate No. 1.

COST OF EWOOR SCHEME.

Main dam being 124 feet high, and impounding one-year's supply, 2,400 million gallons, or $6\frac{1}{2}$ million gallons daily:—

	RS.
5½ miles of channel, with a water-way 4 feet deep by 5 feet wide, at Rs. 80,000 a mile,	4,20,000
5½ miles of ditto, 6 do. by 6 feet wide, at Rs. 1,50,000 a mile,	7,87,500
9½ miles of 26-inch pipe, from Koorla Reservoir to Bombay 1 inch thick, weighing 650 tons per mile, or 6,175 tons, at Rs. 160 a ton,	9,88,000
¾ mile syphon pipe, 48 inches in diameter, and 1 inch thick, weighing 960 tons, at Rs. 160 a ton,	1,53,600
Waste Weir,	1,25,000
Koorla Reservoir, with its outlet works and waste weir,	3,00,000
Works to take the water from the upper to the lower channel,	1,40,000
	29,14,100
Main Dam, 124 feet high, containing 6,260,600 cubic feet, at Ra. 25 per 100 cubic feet of rubble masonry,	15,65,150
No. 8 Dam,	1,61,000
No. 4 Dam,	2,21,000
Outlet works,	2,00,000
	50,61,250
Add 10 per cent. for contingencies, say,	5,06,750
Land,	50,000
	56,18,000
Total,	

Or, say 56½ lakhs of rupees for 10 gallons per head per diem for the present population.

Estimate No. 2.

Main dam being 141 feet high, and impounding two-years' supply, or 4,800 million gallons:—

		RS.
Excepting Dams and outlet works, other works as before, viz.,		29,14,100
Main Dam, 141 feet high, containing 8,300,000 cubic feet, at		
	Ra. 25 per 100 cubic feet of rubble masonry,	20,75,000
No. 3 Dam,	2,51,000
No. 4 Dam,	3,20,000
Outlet works,	2,00,000
		57,60,100
	Add 10 per cent. for contingencies, say,.. .. .	5,76,900
	Land, say,	75,000
		64,12,000

Or, say, 64 lakhs of rupees.

Estimate No. 3.

Main dam being 155 feet high, and impounding three-years' supply, or 7,200 million gallons:—

		RS.
Excepting Dams and outlet works, other works as before, viz.,		29,14,100
Main Dam, 155 feet high, containing 10,743,000 cubic feet of		
	rubble masonry, at Ra. 25 per 100 cubic feet,	26,85,750
No. 3 Dam,	3,51,000
No. 4 Dam,	4,09,000
Outlet works,	2,50,000
		66,09,850
	Add 10 per cent. for contingencies, say,.. .. .	6,60,150
	Land,	1,00,000
		73,70,000

Or, say, 73 $\frac{3}{4}$ lakhs of rupees.

If in place of enlarging the channel for 5 $\frac{1}{4}$ miles, it were decided to have a conduit with a waterway five feet wide by four deep all the way to Vehar, and with a uniform slope of 12 feet per mile, the cost of each of the above projects would be reduced by about 4 $\frac{1}{2}$ lakhs of rupees.

If the project of two dams in place of three were adopted, the cost would be enhanced as follows:—

		RS.
	Project for one-year's supply, as before,	56,18,000
	Add for additional cost of dams,	6,00,000
		62,18,000

			RS
Project for two-years' supply, as before,	64,12,000
Add for additional cost of dams,	7,59,000
		Total,	<u>71,71,000</u>
Project for three-years' supply, as before,	73,70,000
Add for additional cost of dams,	10,09,000
		Total,	<u>83,79,000</u>

In these three cases the quantities of water impounded would be slightly in excess of those obtained by the construction of three dams, but the practical difference is not worth consideration. The greater cost is caused by No. 2 Dam (*vide Plate XLII.*) being more expensive than Nos. 3 and 4 Dams taken together.

H. T.

No. LXXXII.

 THE VEHAR LAKE EXTENSION PROJECT FOR "THE WATER-SUPPLY OF BOMBAY."¹

 By Major Hector Tunnicliffe, R.E.

I HAVE now shown the capabilities of the only two valleys* in Salset which can be considered useful for the supply of Bombay. The quantity of water to be obtained from Kennery is about 3,000 million gallons, and that from Ewoor is 2,400 million yearly—the total from the two valleys being 5,400 million gallons yearly, or nearly 15 million gallons daily, 23 gallons per head per diem for the present population.

I have also shown how high the dams in each valley must be to impound respectively a one, two, and three years' supply. I have, moreover hitherto assumed that the water obtainable in each valley should be stored in that valley; but it is manifest that this need not be done in practice. I wish now to discuss the question, whether it is possible and preferable to store the water elsewhere.

As the Ewoor Lake lies considerably above both Kennery and Vehar no water from these two latter valleys, nor indeed from Toolsee could be thrown into it. Therefore to impound more water in Ewoor than can be supplied from its own gathering ground is not possible.

Some of the water from Ewoor might be thrown into the Toolsee Lake but this lake is a very small one, and it stands in such a position relative to Vehar as to render very high dams objectionable, so that it will not be able to hold more than a three-years' supply from its own gathering ground.

* I am including Toolsee in Kennery.

The Ewoor water could likewise be thrown into Kennery ; but for this lake also, as the reader is aware, a dam of 155 feet high is required to impound a two-years' supply from its own gathering ground only. It is out of the question, therefore, to arrange for it to store a surplus supply from Ewoor.

There is only one alternative left to consider, and I am of opinion that, if it were feasible, it would be best to collect all the water from the Salsette Valleys into the Vehar Lake. This could not be done by raising the present dams. It would be the height of folly to attempt such a thing; but let us see if new dams could be substituted in place of those now existing. New dams might be built behind the present Nos. 2 and 3 Dams, but the lake would probably have to be emptied to make the work safe. It would, however, be impossible to build a new work behind No. 1 Dam. On the western side this dam rests on the slope of a hill which is only just wide enough to give it a hold. A Dam immediately behind it would have nothing to rest against at all. Finding this to be the case, the idea occurred to me that it might be better to abandon No. 1 Dam altogether, and, in place of it, to build two dams lower down the valley—in fact, in the positions originally selected by Mr. Conybeare for what he termed his "Large Reservoir." By reference to the Contoured Plan* of the Vehar Reservoir, the positions of these dams, which were called No. 3 and No. 4 Dams, will be seen. Sections of the valleys at these points have been taken by me, but I regret to say the project has not turned out a promising one. It was, indeed, on account of the heavy nature of the work which these dams would have entailed, that induced Mr. Conybeare to advocate the construction of the smaller lake, and the building of what is now called No. 1 Dam, which in Mr. Conybeare's Plan (as in the Plan above quoted) was called No. 5 Dam. He proposed that these dams should be only 80 feet high, and, moreover, added that "the high-water level might be increased to 84 feet, but not higher, without inconvenience."

Now, I calculate that if the Vehar Lake were made to hold a three-years' supply from the Kennery and Ewoor Valleys in addition to the three-years' supply from its own gathering ground, which is what it holds at present, the surface of the lake would have to be raised 25 feet above its present level. In addition to this, the surface of the ground does not

* *Vide Plate XX., of No. LXXVII., Professional Papers on Indian Engineering, Second Series.*

give us a prospect of a solid foundation for any of the dams at a less depth than about 15 feet. It follows, therefore, that the two dams which would have to be built behind the present Nos. 2 and 3 Dams, which are about 50 feet high, would require to be 90 feet high, and the two dams to be substituted for the existing main dam, which, as it stands, is 90 feet high, would require to be 130 feet high. Nor is this all, for there is a ridge between these latter dams which is lower than the proposed level of the lake, so that a long dam would be required here to prevent the water escaping. There are also one or two other spots round the margin of the lake which would have to be embanked. Altogether, the cost of these works—about 72 lakhs of rupees—would be so out of proportion to the benefits to be derived from them, that we may look upon it as a hopeless task to attempt to store much more water in Vehar than it holds at present. The money that would be required for the new dams could be used to far better purpose otherwise.

H. T.

No. LXXXIII.

ON WELL-FOUNDATIONS.

BY CAPT. ALLAN CUNNINGHAM, R.E., *Hon. Fellow of King's Coll. Lond.*

CONTENTS.

SECTION I.—INTRODUCTION.

Objects proposed, Art. 1.	Imperfection of the data, Art. 7.
Summary of results, Art. 3.	External Forces, Art. 8.
Conditions, Art. 4.	General Treatment, Art. 9.
Stability and Strength, Art. 5.	Resolution of External Forces, Art. 11.

SECTION II.—VERTICAL FORCES.

Experimental evidence, Art. 13.	Direct Re-action of Soil, Art. 20.
Internal fluid pressure, Art. 14.	Frictional ditto, Art. 21.
Water-pressure, Art. 15.	Stability of sinking, Art. 22.
Vertical Re-actions of Soil, Art. 19.	

SECTION III.—HORIZONTAL FORCES.

Wind (Intensity, Total, Centre of Pressure, Moment), Art. 23.	Impact, Art. 38.
Current-pressure, (Subsurface velocity, Intensity, Total, Centre of Pressure, Moment), Art. 27.	Horizontal subsoil Re-actions, Art. 40.
	Stability of sliding, Art. 43.

SECTION IV.—STABILITY OF ROTATION.

Conditions of Stability, Art. 44.	Final Formulæ for Total of, and Maximum and Mean-intensities of Horizontal Subsoil Pressure, Art. 54.
Moments of Stability and Instability, Art. 47.	Example of Pier for Rámangá Bridge, Art. 57.
Mode of <i>definite</i> numerical solution, Art. 51.	

SECTION V.—TRANSVERSE STRENGTH.

General Statement, Art. 58.	Formulæ for Stress-intensities, Art. 65.
Plane of Greatest Stress, Art. 61.	Level of no Tensile Stress, Art. 68.
Strength of Masonry, Art. 62.	Example of Pier for Rámangá Bridge, Art. 69.
Wells classed, Art. 64.	

APPENDIX.

Subsurface velocity, Art. 70.	Centre of pressure of Horizontal Re-actions, Art. 73.
Total Current-pressure, Art. 71.	Resultant Vertical Friction, Art. 74.
Centre of current-pressure, Art. 72.	Reports on Wind-pressure, Art. 75.

1. *Objects proposed.*—It is proposed to investigate in this Paper the Problems of STABILITY and STRENGTH OF *Masonry Well-foundations in quicksand.*

These are Problems of great practical importance, as the Piers of most of the Railway Bridges over the great Indian rivers are in general simply large *Masonry Wells* sunk in many instances in quicksand beds.

[This Paper is intended to be a complete investigation of the whole Problem (as far as the present state of science admits), with the final results in a form immediately suitable for calculations of the practical Engineer: all "results" are accordingly either reduced to simple algebraic formulæ or to "simple statements of fact," and numbered *seriatim*. All detailed mathematical investigations are separated into an Appendix.

A complete numerical solution of one actual Example is given Art., 57, 69, with full references (for all formulæ used) to the Text, so that no difficulty should occur to the practical Engineer in applying the principles and formulæ of this Paper to practice].

2. It may be premised that the particular practical case which gave rise to this investigation was that of the Well-foundations of certain Bridges over the Ganges, Rámangá, Sáí, Gumti and Garrá Rivers on the Oudh and Rohilkhand Railway.

The Bridge over the Rámangá has been selected as an example in illustration of the Methods and Formulæ of this Paper, as being one of the most unfavorable cases, the soil being simply quicksand.

An outline diagram of one of the Piers is given (*Plate XLIV.*, Art. 57). It will be seen that the Pier is sunk 75 feet below the cold weather bed of the stream, and it is supposed that in the worst floods scour might take place to a depth of 50 feet. The greatest surface velocity is believed not to exceed 16 feet per second.

The Girders of the Bridge expose a large surface (317 square feet from Pier to Pier) to the Wind. The Piers themselves are liable to the shock of Drift Timber Logs, and Rafts, and of laden Boats. The numerical data are taken from the official Railway Records.

Summary of Results.

3. In consequence of the length of this Paper, it is considered advisable to give a general summary of the Results.

Section.	Art.	Result.	Brief Statement of Results.
SECTION I.— INTRODUCTION.	5		A "slender Pier in a rapid current over a quicksand bed" may fail in four ways, viz., by <i>sinking, sliding, tilting, or snapping</i> : these give rise to four <i>distinct</i> problems.
	7		The data for these Problems very imperfect.

Section.	Art.	Result.	Brief Statement of Results.
SECTION I.—INTRODUCTION. (Continued.)	7		A proper numerical solution at present impossible. Useful generalizations may however be certainly drawn, and a numerical solution may be found on certain hypotheses. These are the objects of this Paper.
	9		The Problem treated as a Statical Problem. Impact can only be imperfectly allowed for.
	11		The External Forces divisible into two sets of parallel forces, viz., Vertical, and Horizontal (parallel to stream).
SECTION II.—VERTICAL FORCES.	13	4°	The Total Friction developable from the subsoil is <i>alone sufficient</i> to support the Weight of the Well.
		6° 7°	Quicksand can at great depths bear very great <i>direct</i> pressure, and also yield great <i>tangential</i> resistance, and is therefore semi-solid.
	15		Water-percolation does not affect the "Whole Pressure" of the upper courses of Masonry on the lower: that "Whole Pressure" is <i>always</i> simply the Weight of those courses.
	16		Water having access to a Well's base exerts an <i>upward</i> pressure equal to the Weight of the fluid displaced, which is wholly conducive to Instability (of Rotation). In questions of Vertical and Rotary STABILITY this is conveniently allowed for by reducing the "effective heaviness" of the <i>immersed</i> masonry by 62½ lbs. per cubic foot.
	18	2°	Water-percolation seriously reduces a Well's TRANSVERSE STRENGTH. The Masonry of the Wells should therefore be set in good cement, and bonded vertically with iron ties.
	20	(3)	The Vertical subsoil Re-actions, both "Direct" and Frictional, always set <i>upwards</i> , and are always conducive to INSTABILITY.
	21	(6)	
	22		There appears danger of Wells failing <i>by sinking</i> under the peculiar action of the Disturbing Forces after full scour has taken place. Experimental data not available for a numerical estimate.
SECTION III.—HORIZONTAL FORCES.	23		Records of Wind-pressure for India very imperfect. Maximum Wind-pressure in Oudh is 40 lbs. per sq. ft., and in Lower Bengal 50 lbs. per sq. ft.
	24	(7) to (12)	Formulae for Total Wind-Pressure, and Moment of the same.
	26		
	27		Laws of Current-pressure complex, and imperfectly known.
34			

Section.	Art.	Result.	Brief Statement of Results.
SECTION III.—HORIZONTAL FORCES. (Continued.)	28		Subsurface velocity varies as abscissæ of a parabola whose ordinates represent depths.
	29 to 39	13 to 29	New and simple formulæ proposed for Subsurface Velocity and for Intensity, Total, Centre, and Moment of Current-pressure on Well and on Drift Mass.
	41	34	The Disturbing Forces increase both the up-stream and down-stream Horizontal Re-actions of the soil, and raise the centre of pressure of the former and depress that of the latter.
	43		Wells should be sunk below level of "no motion" of subsoil. This level is in this Problem the "virtual bed" of the current.
	SECTION IV.—ROTATION.	45	
46			Point chosen as "Centre of Moments" indifferent. The Re-actions of soil cannot be disregarded (as in Structures on rigid Foundations).
48		(38)	Resultant Moment of <i>all</i> the Vertical Forces is a Moment of Stability.
49		(39)	Increased sinking increases the Moment (of Instability) of the Disturbing Forces, and also the available Resultant Moment (of Stability) of Horizontal subsoil Re-actions, the latter in <i>higher</i> ratio.
ib.		(40)	The Horizontal subsoil Resistance is the <i>chief</i> element of
ib.		(41)	Stability of Rotation, and the Pier's Weight is a <i>comparatively unimportant</i> element.
ib.		(41)	Stability of rotation can only be secured by deep sinking.
50			Stability of rotation cannot be <i>with certainty</i> numerically estimated for want of experimental data on nature of subsoil re-action.
51			By making certain hypotheses a <i>highly probable</i> numerical value may be found for the intensities of pressure on the soil caused by the Disturbing Forces.
54 to 55		(49) (53)	Formulæ for Total of, also for Mean and Maximum Intensities of, Horizontal subsoil Resistance on these hypotheses.
55 to 57			It rests with the practical Engineer to decide in each case whether a particular soil can bear these pressures. Example—Pier for Rámangá Bridge. Maximum pressure intensities on subsoil found.

Section.	Art.	Result.	Brief Statement of Results.
SECTION V.—TRANSVERSE STRENGTH.	61		The Plane of Greatest stress lies at a short distance below the current bed, probably about $\frac{1}{4}$ of depth of sinking. The Stresses at this plane only require investigation.
	62		No reliance should be placed on vertical Tenacity of Masonry simply set in mortar.
	65	(54)	Formulae for Greatest, Mean, and Least Stress-intensities at plane of Greatest Stress.
	68	(54a)	Slender Piers suffer <i>some</i> Tensile Stress <i>nearly throughout</i> their length. Such Piers if simply set in Mortar are dangerously liable to fail by opening of joints under Tension; they should for safety be tied with vertical Iron Ties throughout.
	68		A solid cylindric pier is one of the <i>weakest</i> forms as regards Transverse Strength.
	69		Example.—Pier for Rámgangá Bridge. Longitudinal Stress-intensities found. This Pier is strong enough if tied with vertical iron ties throughout, but if <i>simply set in mortar</i> its Transverse Strength is doubtful.

4. *Practical Conditions.*—The great rapidity of the large Indian rivers in flood, and the shifting nature of their beds (often quicksand) lead to the practical condition that

1°. "The natural waterway must be as little as possible diminished by introduction of Piers," and consequently

2°. "The Piers must be as slender as is compatible with the requisite STABILITY and STRENGTH."

5. *STABILITY and STRENGTH.*—The consequence of these particular practical conditions, viz., "a slender Pier in a rapid current over a quicksand bed" is that the *complete* Treatment of the Problem requires the consideration of a number of elements most unusual in Masonry Structures, viz. of the *distinct* problems of STABILITY and STRENGTH, and moreover of several distinct forms of the former. In fact the Wells appear liable to fail in four distinct ways, specified below, each of which gives rise to a distinct Problem as stated.

No.	Manner of falling.	Problem of
1	By sinking as a whole,	Vertical Stability.
2	By sliding as a whole,	Lateral Stability.
3	By tilting over as a whole,	Rotary Stability.
4	By cross-breaking or snapping,	Transverse Strength.

[Liability of failure by Shearing is omitted from the above enumeration, as it is a matter of practical experience that *solid* Masonry structures do not fail by shearing across under Transverse Strain].

It appears that Well-foundations as hitherto constructed have usually failed by tilting over as a whole, *i. e.*, by want of Stability of Rotation. This Problem will therefore receive especial attention, *see* Section iv.

6. *General interest of the Problems.*—It is very seldom that so many distinct manners of failure really require consideration in Masonry Structures. The present Problems presents in consequence considerable interest even from a theoretical point of view.

[The Problem as set forth in its generality is *an almost untried* one. The author has had the advantage of consulting a Report on a portion of the general Problem (made for information of the Outh and Roshilkhand Railway), by E. Bell, Esq., C.E. Mr. Bell's Report deals *solely* with the Problem of TRANSVERSE STRENGTH. Mr. Bell considered the Problem of STABILITY at present *insoluble*.

The author has had the advantage of discussing the general Problem of STABILITY with Mr. J. Elliott, M.A., Mathematical Professor, Muir College, Allahabad, and is much indebted to him for advice. The general treatment of the difficult question of Friction (Art. 21) is due to Mr. Elliott].

7. *Imperfection of the data.*—The chief difficulty attending this problem is the great imperfection of the practical data, and particularly of the two following:—

- (1). Laws of Current pressure.
- (2). Laws of Resistance of subsoil.

The laws of the former are imperfectly known, but so little is known of those of the latter, that (as will appear in the sequel) it is simply impossible (at present) to produce with real certainty any *definite* numerical solution of any of the four Problems proposed in Art. 5.

Nevertheless (as will appear) many useful generalizations may be certainly drawn from a critical discussion; further by adopting certain probable hypotheses as to the nature of subsoil Resistance, *definite* numerical solution of the Problems may be obtained.

This Paper aims therefore

- (1). At establishing useful generalizations.
- (2). At *definite* numerical solutions of the Problems upon certain probable hypotheses as to nature of subsoil resistance.

External Forces.

8. The External Forces may be divided into two sets; (1), APPLIED FORCES; (2), RE-ACTIONS, which are of course *developed by* the former.

The Applied Forces are of two kinds—

- 1°. VERTICAL: these are simply the Weight of the Superstructure and Structure.
- 2°. HORIZONTAL or nearly so: these are
 - (1). Wind on the Superstructure.
 - (2). Wind on the Piers.
 - (3). Impact of floating Drift.
 - (4). Current on floating Drift caught by the Piers.
 - (5). Current on the Piers.

It is convenient (for brevity) to class the whole of these last under the general term “Disturbing Forces.”

The Re-actions will be considered hereafter.

General Treatment.

9. The first question that naturally presents itself is the following:—
“Is the Problem to be treated as a question in Dynamics (Kinetics), or in Statics”?

Inasmuch as the “Disturbing Forces” (Wind, Current, and Impact of Drift) are all *vires vivæ*, the proper scientific treatment would be as a problem in Kinetics. The question would thus present itself in this form:—

“Is the Potential Energy of the Re-actions equal to the Kinetic Energy of the ‘Disturbing Forces.’”

The estimation of Energy would require that *all* the co-efficients of elasticity of the masonry and subsoil should be known. As these co-efficients are however quite unknown, the problem cannot (at present) be solved in this form.

Two of the Disturbing Forces, viz., Wind, and Current, have however been reduced (by experiment) to equivalent STATICAL PRESSURES, so that as far as these are concerned, the Problem may be treated as a question in Statics (*i. e.*, of equilibrium).

No such experimental reduction has however been made in the case of Impacts of solid bodies (*e. g.*, Drift-masses) so that the effect of Impact cannot *really* be included in a solution as a case of Statics, and for the reasons before given the Kinetic solution is also impossible.

An imperfect equivalent for the *effect* of Impact, but one which will probably meet all *practical* requirements, is to substitute a “Mass of floating débris” as caught against the Well and there exposed to the full power of the current, so that “Impact” is *replaced* by a STATICAL PRESSURE.

N. B.—The size and shape of this hypothetical floating mass must be assigned as a *purely empirical* question, by the practical Engineer. Theory affords absolutely

no guide to this assignment. A mass presenting 100 square feet broadside to the current has been assumed in the Example, Arts. 57 and 69.

The whole of the Disturbing Forces having been thus reduced to Static Pressures, the Problem may now be treated as one in Statics.

10. It will be assumed that—

“ Piers should be designed to meet the case when the Disturbing Forces “ *simultaneously* attain their maxima, and also set in the *same* direction “ (down-stream).”

[This is obviously the condition most unfavorable to the Piers, for under any other condition the Disturbing Forces will be either—(1) actually not at their maxima or (2) partially counteracting each other].

11. *Resolution of the External Forces.*—The Vertical Forces are necessarily “ a parallel system.” The Disturbing Forces may be assumed (with sufficient accuracy for this Problem) to be *horizontal* in direction, and by the limitation to the case of their setting in the *same* direction (Art. 10) they become “ a system of parallel horizontal forces.” Moreover in symmetrical Wells (the usual case), the Disturbing Forces may be assumed (with sufficient accuracy for this problem) to be *symmetrically distributed* about the vertical axis of the Well. It follows that

1°. The resolved parts—across the stream’s direction—of the action of the Disturbing Forces on the curved outline of the Well *balance* each other.

2°. The Resultants of each of the Disturbing Forces pass through that axis.

Inasmuch as the Re-actions must be equal and *opposite* to the Applied Forces, they may be *similarly* classified.

It follows that the “ External Forces ” may (for most purposes) be reduced to two sets of “ parallel forces,” viz.,

1°. A set of vertical forces.

2°. A set of horizontal forces (parallel to the stream).

It is convenient to consider the Vertical and Horizontal Forces separately, and in the order indicated in the Table of Contents, *q. v.*

SECTION II.—VERTICAL FORCES.

12. *Vertical Forces Classed.*—The question of the “ effective heaviness ” of *immersed* masonry is really a very serious one, as enormously affecting the *quantity* of Masonry requisite to Stability. As this is a question on which the most opposite opinions have been advanced, it will be discussed at some length. Consider all the vertical forces:—these are*

* It is convenient to estimate *upward* Forces as positive; all Weights being downward Forces are thus negative.

- 1°. The WEIGHT of the Pier, (- W).
- 2°. The WATER-PRESSURE, *upwards* or *downwards* on all parts to which fluid has access *from below* or *from above* respectively, (W').
- 3°. The RE-ACTION of the soil, upwards, (R).
- 4°. The FRICTION (F) between the sides of the Pier and the soil, *upwards* or *downwards*, according as the tendency of the Pier is at any moment to *sink deeper* or to *rise* (vertically)—or the vertically resolved parts of the partial Frictions on all sides of the Pier, when the tendency to motion is not vertical.

Then, clearly *at all times* when the Pier is neither sinking nor rising, the following equation obtains

$$- W + R + W' \pm F = 0 \dots\dots\dots(1).$$

13. *Experimental evidence.*—The chief difficulty attending this part of the investigation is the *want of experimental evidence* on the nature of “internal subsoil pressure.” The following are apparently the only known data: as experimental evidence is the basis of all scientific investigations, they will be made the basis of the present investigation. The inferences which will be drawn from them should be carefully considered, as most of this investigation is simply the necessary conclusion from those “inferences” as premisses.

It appears that:—

(1). In some Wells the water has been known to stand at a higher level (during the period of sinking) inside the Well than outside it.

Inference. It follows that in those cases,—

1°. Quicksand, even at great depths, permits thorough permeation of water, so that water has *access to the base* of Wells in quick-sand.

2°. The “internal fluid pressure” at the base of the Wells was *somewhat greater* than the “hydrostatic pressure” (of the water).

Also in some Wells—

(2). It has been found, during the period of sinking, that the Weight of the (then hollow) Well was not sufficient to cause its own sinking, even when all direct support from the *subjacent* soil had been removed (by the removal of that soil); and further, that the Weight of the (hollow) Well together with the heaviest Weight (of many tons of iron rails) that can in practice be laid on the Well is (after sinking a great depth) not sufficient to make the Well sink further, even when all direct support from the *subjacent* soil has been removed (by removal of that soil), in fact that all practically available mechanical appliances eventually fail to produce further sinking.

Inference.—Since by the removal of the subjacent soil, its *direct* Re-action ceases, *i. e.*, $R = 0$, hence $- W + W' + F = 0$, in such cases: thus it appears that:—

3°. The Total Weight (W) of the Well and its superstructure were supported solely by the upward Water-pressure (W') and Friction (F).

4°. The Total Vertical Friction (F) which *can* thus be developed in support of the Pier is *very great*.

5°. The Total Normal Pressure of the subsoil against the sides of the Pier (by which cause alone can the Friction be developed) must be *very great indeed*.

6°. Quicksand is able, at any rate at great depths, to sustain very great *direct* (normal) pressure.

7°. Quicksand, although thoroughly permeable by water (even at great depths, *See* Inference 1°), is at great depths capable of exerting considerable "Tangential Resistance", (to which property alone the Friction is due), and is therefore at such depths a "semi-solid," or *very imperfect* fluid.

[*N.B.*—Sensibly perfect still fluids (*e. g.*, still water) exercise no sensible Tangential Resistance.]

The great practical importance of some of these inferences, especially 1°, 4°, 6°, 7°, will appear in the sequel.

14. *Internal fluid-pressure*.—The law of variation of "internal pressure" in *current fluid* is involved in equations which have not yet been solved. It is however known in a general manner that pressure *decreases* with increased velocity, so that "internal fluid-pressure" in current fluid is generally *less* than the *hydrostatic* pressure.

It appears nevertheless (*see* Inference 2°) that the "internal fluid-pressure" at the base of some of the Wells has been known to be somewhat *greater* than the hydrostatic pressure (of the water): this is probably due to the quicksand being a sort of "imperfect fluid," of *greater density* than water.

It appears therefore that it will be a sufficiently approximate method for the present problem to estimate the "internal sub-soil fluid-pressure", (*i. e.*, of the quicksand or mixture of sand and water) as *the same* as the "hydrostatic pressure" of the water alone.

[At the same time that the difficulty of estimating "internal fluid-pressure" of current fluid is thus avoided, it is evident that *some* allowance has been made for semi-fluidity of quicksand: as to the sufficiency of this allowance, be it observed that the allowance required can hardly be very great, as it seems difficult to imagine that the subsoil could supply the *great* Total Friction known to be developable (Inference 4°) unless its state of aggregation at great depths was more approaching to that of a solid than a fluid (*see* Inference 7°).

On this particular hypothesis, no further notice need be taken of the "semi-fluidity" of the quicksand].

15. *Water-pressure*.—Still water is (unless absolutely confined) capable of yielding and also of transmitting only its proper "hydrostatic pressure" (neither more, nor less than that due to its depth), and that only *uniformly* and in all directions at once, and cannot therefore transmit either variable Pressure, or any Tension.

Further there is (necessarily) an *upward* Water-pressure on all parts

to which fluid has access *from underneath*, (which might be supposed to diminish the “effective weight” of the masonry above,) but as this is necessarily accompanied by a simultaneous and equal *downward* Water-pressure on the parts below, (to which the fluid of course has access *from above*,) it follows *as a resultant effect* that the

“Whole Pressure of each horizontal Stratum on those below is simply *its own Weight*”,—or in other words

“Permeation by water does not alter the TOTAL PRESSURE of the upper courses of Masonry on the lower” (although, as presently shown, it may greatly alter the *distribution* of that Pressure).

16. *Effect of Water-pressure on Stability.*—As regards STABILITY (both Vertical and Rotary) of the Pier as a whole, also as regards STABILITY (of both kinds) of the part above a fracture (should complete *fracture* occur below water level), the *upward* Water-pressure exerts an *upward* “Re-action” against the base and parts to which it has access from below, which is *equivalent* to reducing the “effective heaviness” of the *immersed* masonry by about 62·5 lbs. per cubic foot (the “heaviness” of water).

[*N.B.*—This may be *conveniently* allowed for (in questions of *Vertical* and *Rotary* Stability only) by estimating the “effective heaviness” of *immersed* masonry as 62½ lbs. per cubic foot less than that of masonry in air. It must be borne in mind however that this method is suggested solely for *convenience* in numerical calculation. It must be carefully remembered that the “whole weight” of masonry, and also the “whole upward Water-pressure,” are *distinct* forces, the former wholly effective in producing STABILITY, the latter wholly effective in producing INSTABILITY.]

17. *Effect of Water-pressure on Transverse Strength.*

In any case, the Water having access to the base of the Pier (*see* Inference under 1°) yields an *upward* Pressure (viz., its “hydrostatic pressure”) *uniformly distributed* over the base. This effects Transverse Strength to the extent that the distribution of Stress throughout the Pier *must be such* that the Pier shall yield a *downward* Pressure on its base, which *must not be less at any point* of its base than that “hydrostatic pressure”, (but may be greater).

18. The Transverse Strength is further affected as follows—

1°. If the Pier be impervious to water.

2°. If the Pier be in parts permeated by water.

1°. *Pier impervious.*—If the Pier be impervious to water, the state of Longitudinal Stress throughout the Pier is only affected as above stated.

2°. *Pier pervious.*—If the Pier be *partly permeated* by Water :—then inasmuch as a *solid* Pier under Transverse Strain (due to the applied Forces of Wind and Current) is at any horizontal plane “in a state of Longitudinal Stress” which is generally

and set the *Disturbance* varying with the distance from a certain vertical line in that plane. And we shall be obliged to suppose, as before, that *Disturbance* varies with a sine or cosine of the distance from the origin of *Disturbance* in the plane. The first effect of this *Disturbance* is to produce a *Disturbance* in the vertical reaction force, and a *Disturbance* in the horizontal reaction force. The *Disturbance* in the vertical reaction force is that which we call the *Disturbance* in the vertical reaction force, and the *Disturbance* in the horizontal reaction force is that which we call the *Disturbance* in the horizontal reaction force.

It will be seen, therefore, that the effect of a *Disturbance* in the vertical reaction force is to produce a *Disturbance* in the horizontal reaction force, and a *Disturbance* in the horizontal reaction force is to produce a *Disturbance* in the vertical reaction force. The *Disturbance* in the vertical reaction force is that which we call the *Disturbance* in the vertical reaction force, and the *Disturbance* in the horizontal reaction force is that which we call the *Disturbance* in the horizontal reaction force. It will be seen, therefore, that the effect of a *Disturbance* in the vertical reaction force is to produce a *Disturbance* in the horizontal reaction force, and a *Disturbance* in the horizontal reaction force is to produce a *Disturbance* in the vertical reaction force.

It will be seen, therefore, that the effect of a *Disturbance* in the vertical reaction force is to produce a *Disturbance* in the horizontal reaction force, and a *Disturbance* in the horizontal reaction force is to produce a *Disturbance* in the vertical reaction force. It will be seen, therefore, that the effect of a *Disturbance* in the vertical reaction force is to produce a *Disturbance* in the horizontal reaction force, and a *Disturbance* in the horizontal reaction force is to produce a *Disturbance* in the vertical reaction force.

It will be seen, therefore, that the effect of a *Disturbance* in the vertical reaction force is to produce a *Disturbance* in the horizontal reaction force, and a *Disturbance* in the horizontal reaction force is to produce a *Disturbance* in the vertical reaction force. It will be seen, therefore, that the effect of a *Disturbance* in the vertical reaction force is to produce a *Disturbance* in the horizontal reaction force, and a *Disturbance* in the horizontal reaction force is to produce a *Disturbance* in the vertical reaction force.

It will be seen, therefore, that the effect of a *Disturbance* in the vertical reaction force is to produce a *Disturbance* in the horizontal reaction force, and a *Disturbance* in the horizontal reaction force is to produce a *Disturbance* in the vertical reaction force.

I. *Disturbance* in the vertical reaction force.

II. *Disturbance* in the horizontal reaction force.

It will be seen, therefore, that the effect of a *Disturbance* in the vertical reaction force is to produce a *Disturbance* in the horizontal reaction force, and a *Disturbance* in the horizontal reaction force is to produce a *Disturbance* in the vertical reaction force. It will be seen, therefore, that the effect of a *Disturbance* in the vertical reaction force is to produce a *Disturbance* in the horizontal reaction force, and a *Disturbance* in the horizontal reaction force is to produce a *Disturbance* in the vertical reaction force.

A *Disturbance* in the vertical reaction force is to produce a *Disturbance* in the horizontal reaction force, and a *Disturbance* in the horizontal reaction force is to produce a *Disturbance* in the vertical reaction force. It will be seen, therefore, that the effect of a *Disturbance* in the vertical reaction force is to produce a *Disturbance* in the horizontal reaction force, and a *Disturbance* in the horizontal reaction force is to produce a *Disturbance* in the vertical reaction force.

$$R + F = W - W.$$

It seems sufficiently evident that the only effect of the *Disturbance* Forces being *horizontal* in the *vertical* Reactions is—so long as equilibrium holds—to alter their *distribution* and therefore to alter the *position* their Resultant, but not to alter the *magnitude* of that Resultant which remains at the same amount, viz. $(W + R - F) = W$, otherwise it

Pier would sink or rise, as a whole, vertically, which would destroy its use as a support for Girders.

Observing now that the Upward Water-pressure (W') is for a *very slight* displacement (tilting) of the Pier a quantity sensibly constant, and that the Weight of the Pier (W) is also a constant, it follows that

“The Total Vertical Re-action of the subsoil ($R + F$) is constant for a very slight displacement (tilting) of the Pier,”

$$i. e., (R + F) = W - W' \text{ a constant quantity } \dots\dots\dots(2).$$

But it seems almost impossible to *separate* these forces R, F : it is known (*see* Art. 11—(2)) that the Total Vertical Friction (F) developable is in the absence of the Direct Re-action ($R = 0$) of *itself* sufficient to support the Weight of the (hollow) Pier together with the heaviest Load that could in practice be laid on it—when not under the action of the Disturbing Forces. Nothing else is *certainly* known.

20. *Direct Vertical Re-action of the soil.*—It was shown (*see* Inference (5)) that quicksand is at great depths capable of sustaining great pressure and therefore of yielding great *direct* Re-action (R).

[*N.B.*—Although in the course of sinking, the subjacent soil is continually removed, so that the Pier does not *then* rest on the soil, still it seems almost certain that the contact of the soil with the base of the Pier is eventually renewed either by the final heaving of the Pier with concrete, or by the imperfectly fluid quicksand eventually refilling any vacancy that may be left below the Masonry].

It has been explained (Inference 7°) that quicksand is at great depths probably a sort of very imperfect fluid; reasons were given (Art. 14) for assuming that a sufficient allowance had there been made for the “fluid-resistance” of the quicksand, and for assuming it was at great depths otherwise a semi-solid capable of sustaining considerable tangential stress, and therefore also capable of bearing direct pressure of *varying intensity*, and therefore also of yielding Direct Re-action of like *varying intensity*.

The general effect of Lateral Forces applied to a Pier resting on *such a material* (as supposed) would be to alter the distribution of the pressure (of its Weight) on that material, viz., to diminish the pressure on the *near* side and increase it on the *far* side, thereby throwing the Resultant Pressure towards the *far* side; the direct Re-action of the soil would of course exactly follow suit: and this effect would go on increasing with an increase of the Applied Forces to an extent depending on the actual power of the subsoil of sustaining *varying* pressure.

But inasmuch as it seems impossible to suppose that the quicksand can

This will be evident from the figure where the particles of masonry P, P' clearly tend to move in the direction Pp, P'p' (at right angles to OP, OP' which are perpendiculars from P, P' on the line OO' (the axis of rotation), so that OP, OP' are radii of, and O, O' centres of motion of the points P, P'), i. e., away from all contiguous particles of soil, (and not to slide over them).

[A common beer-bottle is a very good model in illustration].

Kinetic friction.—It seems probable that, at the same time that the Pier tends to move (as a whole) away from its contact with the soil on the near side (i. e., side of application of the lateral Forces), the soil being quick-sand tends to fill the vacancy, and so renew the contact ; the particles of sand in so

moving probably fall, i. e., impinge in a somewhat downward direction against the masonry, thereby expending part of their downward "vis viva" (Energy of motion) on the mass of the Pier, and also causing downward "friction of motion", which is of course conducive to Stability.

The nascent velocity of the impinging sand-particles will however be very small, so that their nascent downward Impact and the simultaneous nascent downward Kinetic Friction will also be very small, and should be neglected in comparison with the large Forces in action.

The state of the Frictional Forces over the far side is more difficult to form a clear conception of. In the state of incipient motion (round the point O in the far edge of the base), every particle of masonry on the far side tends to rise and at the same time press harder on the contiguous soil, so that true sliding of the masonry over the sand tends to take place : true Friction is thus developed,—opposite at every point to the direction of incipient motion of that point, and proportional to the pressure at that point, and therefore—generally different both in direction and intensity at every point of the far side. Resolving these partial Frictions vertically, the following important result follows—

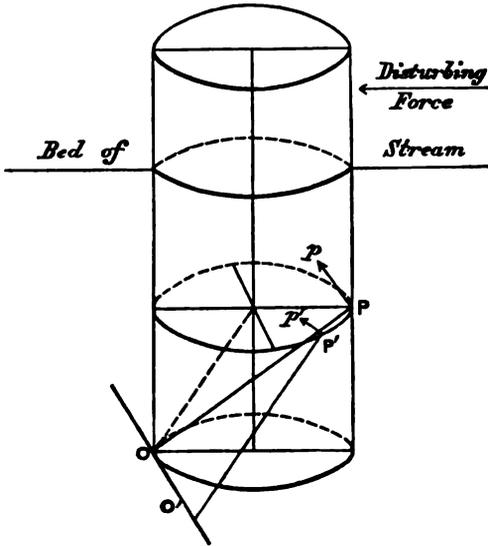

“ At the instant of incipient motion, the partial vertical Frictions are zero at the diametral plane which lies across the stream (*i. e.*, perpendicular to the direction of the applied lateral Forces), and increase in intensity towards— and attain a maximum at—the far vertical edge of the Pier”, } (5).

The actual distribution of the vertical friction-intensities, and the actual intensity at any one point are entirely unknown. There is a natural limit to the maximum friction-intensity, viz., that due to the maximum pressure-intensity which the soil can bear.

It is possible that,—at the same time that the distribution of vertical Friction changes as explained,—some of the partial vertical frictions may set *downwards*; it is possible also that their Resultant (F) may change in magnitude; but, whatever that change may be, the equation

$$R + F = W - W' \text{ (a constant quantity),}$$

must certainly *obtain at all times*, (otherwise the Pier must sink), *i. e.*, the Resultant Vertical Re-action of all kinds (R + F) must be *unchanged both in magnitude and direction*.

It is obvious from what precedes that the Resultant (F) can never approach to coincidence with the far edge of the Pier, but must always fall *within* the base.

Observing also, that it is hardly possible that the Direct vertical Re-action (R) of the soil (quicksand) could of itself sustain the whole downward pressure (W - W'), there follows the important result—

“ The Resultant Vertical Friction always sets *upwards*, and is always } .. (6).
conducive to Instability”,

VERTICAL STABILITY—STABILITY OF SINKING.

22. It is clearly essential to the use of a Pier that it should *not sink further*, once the superstructure is commenced.

As there seems (to the author) danger of Piers in quicksand sinking further under the peculiar action of the applied Forces, the question should receive consideration.

Assuming that the Wells are sunk till mechanical appliances fail to sink them further, and also that the superstructure is put on *before* the maximum scour has taken place, (an almost certain event, as the supposed maximum scour might not occur for years,) it is known that the *actual depth* of soil sunk through can yield sufficient vertical Resistance (Re-action) of all kinds (*i. e.*, both direct upward Pressure on the base, and upward Friction on the sides), to support the greatest Load (say W) that

has ever been placed on the Pier, so that *at that time* (previous to maximum scour) the equation $-W + W' + R + F = 0$, certainly obtains.

But when full scour has taken place, *many feet* (sometimes 50 feet) in depth of the soil which previously supplied the Total vertical Friction (F), are completely removed, and the remaining subsoil (still in contact with the Pier) is probably much reduced in cohesiveness—(both by the removal of the superincumbent sand, and by more thorough water-percolation)—and therefore in power of yielding direct pressure whether on the base, or on the sides (by which latter pressure alone can friction be developed).

But the action of the “Disturbing Forces” is further unfavorable to STABILITY (of this kind), because they tend to alter the distribution of the partial vertical Re-actions—both Direct and Frictional,—which the soil must supply, by *accumulating* the greatest intensity of those Re-actions towards the far side—so that though the soil is called on to supply only the *same* Total Vertical Re-action ($R + F = W - W'$) as before, it has to supply it in a far less favorable manner, viz., by supplying pressure (upwards on the base, normal on the sides) of far greater intensity in the neighborhood of the far (down-stream) side than before. There is of course a natural limit to this, viz., the greatest pressure-intensity which the soil can supply, after full scour has taken place. If the partial pressures caused by the external Forces anywhere exceed this, motion must take place, *i. e.*, the Pier *must sink*.

[The experimental data required for properly estimating numerically the greatest pressure-intensity that the Disturbing Forces will cause are entirely wanting. An attempt will be made on certain hypotheses later].

SEC. III.—HORIZONTAL FORCES.

WIND.

23. *Wind-intensity*.—The data for *maximum* intensity in India are very defective. There are as a rule* no self-registering anemometers at the Indian Meteorological Stations from which the “Maximum Wind-pressure” could be inferred. There appear to be such only at Calcutta and Lucknow.

* As appears from the replies to queries addressed by the author to the Surveyor General of India, and to the Meteorological Reporters of Madras, Bombay, Bengal, North-West Provinces and Punjab.

From the records* of these anemometers it may be fairly assumed that the Wind will *occasionally* reach a Maximum whose "Statical equivalent" is 50 lbs. per square foot in Lower Bengal; 40 lbs. per square foot in Oudh.

24. *Total Wind-Pressure.*—It is considered sufficiently accurate† (Design of Structures) to Estimate Wind-pressure as *horizontal* and *uniform intensity* at all moderate heights, also to estimate as follows† effect on *curved* Piers,

$$\left. \begin{array}{l} \text{Total Wind-pressure (parallel to} \\ \text{Wind's direction) on a Vertical} \\ \text{cylinder or conic frustum, ..} \end{array} \right\} = \frac{1}{2} \text{ of } \left\{ \begin{array}{l} \text{Total Pressure on a Ver-} \\ \text{tical diametral plane} \\ \text{broadside to wind, ..} \end{array} \right\} \dots\dots (10)$$

- Then if w' = Maximum Wind-pressure in pounds per square foot.
- A_g = Area of Girder-surface exposed to Wind in square feet.
- A_M = Area of Vertical Diametral section of Pier exposed.
- P_g = Total Wind-pressure on Girders.
- P_M = Total Wind-pressure (parallel to Wind) on Masonry exposed.
- $P_g = w' \cdot A_g$
- $P_M = \frac{1}{2} \cdot w' \cdot A_M$

25. *Centres of Wind-pressure.*—It follows from the preceding that—
 1°. The Centre of Wind-pressure on Girders is near the middle of their height, when the Girders have (as would usually be the case) straight flanges, and have tolerably equal areas of metal (exposed to the Wind on either side of their mean line ("neutral surface").

2°. The Centre of Wind-pressure on the Piers is the centre of gravity of the exposed vertical diametral section. But inasmuch as in practice the taper of the Piers is usually very slight, this point is *near* the middle of the height of that exposed section.

It is considered that it will be sufficiently accurate for the present Problem to assume that—

"The Centres of Wind-pressure on the Girders and Piers are at the middle of their heights,"

26. *Moment of Wind-pressure.*—It follows from the preceding that this may be expressed in the following simple manner:—

$$\begin{array}{l} 1^\circ. \text{ Moment of wind-pressure on Girders, .. } \\ 2^\circ. \text{ Moment of Wind-pressure on Piers, .. } \end{array} \left\{ \begin{array}{l} = \\ = \end{array} \right\} \left\{ \begin{array}{l} \text{Total Pressure} \times \text{height of middle of Girders above centre of moments,} \\ \text{Total Pressure} \times \text{height of middle of exposed area above centre of moments,} \end{array} \right\} \dots (11) \dots (12)$$

* Letters from Meteorological Reporter of Bengal, and Superintendent of Science Department Oudh, in Appendix.
 † Rankine's Applied Mechanics, Art. 215.

Current-pressure and its Moment.

27. It is known that Current-pressure varies as square of velocity which is *itself variable* with the depth.

It follows therefore that neither Total Current-pressure nor its Moment can be expressed by any such simple means as in the case of Wind-pressure.

It will be necessary first to investigate formulæ for the subsurface velocity, and thence for pressure-intensity, Total Pressure, and Moment.

[The formulæ about to be given have been constructed by the author for this Problem, and are, it is believed, now proposed for the first time: their detailed construction is given in the Appendix in order that the Engineer may satisfy himself of their correctness; the results alone are given in the Text so as not to interfere with the discussion on the practical points involved].

Subsurface Velocity.

28. The extensive experiments on the Mississippi and its affluents have conclusively shown* that "subsurface velocity" varies according to such a law that it may be represented by the abscissæ of a parabola whose ordinates represent depths below a certain line, (which is generally the line of greatest velocity, and *below* the surface).

This will be understood from the velocity-diagram (*Fig. 2, Plate XLIV.*), which clearly represents to the eye the law of variation with the depth.

It may be here stated that other Engineers have for this very problem assumed other laws of variation of subsurface velocity, *e. g.*, it has been proposed

1°. To assume the "bottom velocity" as that which will just move sand, and the "mid-depth velocity" as the *same* as that given in Hydraulic Tables as "Bottom velocity" corresponding to the given "Surface velocity", and to consider the velocity between these points as uniformly varying, or—

2°. To assume as "Bottom velocity" that given in Hydraulic Tables as corresponding to the given "Surface velocity", and to consider the intermediate velocities as uniformly-varying.

[No. 1° is that adopted by E. Byrne, Esq., Resident Engineer of the Railway. No. 2° is adopted by E. Bell, Esq., C.E.]

Neither of these assumptions appear to be warranted by any experimental evidence. It may be noted that *with the same data* of surface, bottom, or intermediate velocities, the parabolic theory will always give the *largest* result for the Total Current-Pressure—it is easily seen from the figure (*Fig. 2, Plate XLIV.*), that the parabolic area encloses, *i. e.*, is larger than any area formed *with same data* by simply joining extremities of the lines representing given velocities (*i. e.*, as if the velocity were uniformly-varying).

* Report on Physics and Hydraulics of the Mississippi, by Capt. A. Humphreys and Lieut. H. L. Abbot, 1861, pages 234, 287.

29. The complete determination of the sub-surface velocities, or, which is the same thing, the construction of the representative parabola requires three data, *e. g.*, three (observed) velocities at three different known depths.

The only observed velocity ordinarily recorded (at any rate for Indian rivers) is the "Surface velocity". It seems convenient to take for the remaining data—

- (2) the "bottom velocity", which must be taken from Hydraulic Tables, or assigned by the practical Engineer.
- (3) the position of the axis of the parabola, which is given in the Mississippi Report (pages 262 and 288), by formula (13) (below) as depending in a certain manner on the wind and on the "hydraulic mean depth."

With the following notation slightly altered from that in the Mississippi Report (page 200)—

- d = any depth below surface ; V = velocity at depth d , (required).
- D = depth of bed ; V_D = bottom velocity, (assumed).
- d' = depth of axis of parabola ; V' = velocity at depth d' , (usually the greatest).
- o = depth of surface ; V_o = surface velocity, (observed),
- r = hydraulic mean depth ;
- f = force of Wind, estimated as zero for a calm, and 10 for a hurricane, reckoned positive or negative according as it sets up or down-stream.

Then the Mississippi Report gives (pages 262, 288) for the position of the axis :—

$$d' = (.317 + .06 f) \cdot r \dots \dots \dots (13).$$

Thus for a half hurricane down-stream (f = about $- 5$), it follows that $d' = o$, *i. e.*, the axis of the parabola (which is also the line of greatest velocity) lies in the surface."

[This is an important simplification of formula (13) as will appear below].

30. *Accurate formulæ.*—The following formulæ (for details see Art. 70) follow immediately from the parabolic theory :

$$V = V_o - (V_o - V_D) \cdot \frac{d (d - 2d')}{D (D - 2d')} \dots \dots \dots (14)$$

$$V' = V_o + (V_o - V_D) \cdot \frac{d'^2}{D (D - 2d')} \dots \dots \dots (15).$$

Approximate formulæ.—For reasons given below, it seems sufficiently accurate in the present Problem to assume $V_D = o$, $d' = o$, which reduces formulæ (14) and (15) to the much simpler forms :—

$$V = V_o \left(1 - \frac{d^2}{D^2} \right) \dots \dots \dots (16).$$

$$V' = V_o \dots \dots \dots (17).$$

[The Velocity-diagram (Fig 2, Plate XLIV.) has been constructed from formula (16)]·

31. *Explanation of assumptions* $V_D = 0, d' = 0$.—It is probable that the portion of bed scoured out near the Piers is often limited to a saucer or funnel-shaped hollow round the Pier, inside which there will be sometimes violent eddying and boiling action ; but so long as this violent action lasts, *scour is going on*. The most unfavorable time for the Pier appears to be, when the scour has reached its full depth, after which time the eddying and surging action must be comparatively small, as (by hypothesis) the scour is not increasing. It seems further probable that the most unfavorable time to the Pier will be when this scour has been very extensive in the neighborhood of the Pier, so that the Pier is exposed to a Current of the full depth of scour, that is to say to a Current whose bed has been lowered to scour level, and which is throughout its depth effective as a Current in pressing on the Pier.

This hypothesis enables the whole effect of the current to be reduced to a Statical Problem of Pressure ; the present state of Hydraulic Science does not enable the effect of the eddying and plunging action to be in any (beyond a hypothetical) way included, but if this hypothesis be admitted as the most unfavorable to the Pier, it appears unnecessary further to consider such eddying action.

Under this hypothesis the depth of river-bed, and of scour in the neighborhood of the Pier are considered as the same : this must of course be one* of the data, either from actual observation or assigned by the Resident Engineers.

32. But further the Bottom velocity (V_D) seems (to the author) likely to be so small for a quicksand bed, (the case in hand,)—perhaps that which will just disturb loose sand—compared with the Surface velocity (V_0), that it might be neglected in forming an approximate formula.

[N.B.—The ordinary Hydraulic Tables profess to give the “ Bottom velocity ” corresponding to various “ surface velocities ”, but the fact is that such Tables are constructed from formulæ in which the “ constants ” were derived chiefly from experiments on artificial conduits. The results appear (to the author) totally inapplicable to quicksand. Ex. The “ Surface velocity ” in the Rámangá has been recorded as 16 feet (= 192 inches) per second. By Du Buat’s formula the corresponding “ bottom velocity ” would be $(v - 2\sqrt{v} + 1)$ inches, i. e., 165·8 inches per second—no matter what the material of the bed was. Is this possible in a quicksand bed ? The bottom would be surely scoured away.]

33. *Further simplification* $d' = 0$.—It will be observed (Eq. 14) that the sub-surface velocities (V) depend both on the surface velocity V_0 and on d' , and therefore (by Eq. 13) on f (the force of the wind). Now the objects of the present inquiry are to ascertain both the Greatest Current-Pressure, and the Greatest Moment of Current-Pressure on the Pier.

It is evident that the sub-surface velocities (V) increase with the surface velocity (V_0) which is itself re-inforced by a strong down-stream wind. On the other hand, a down-stream wind (f negative), raises the axis of the parabola (see Eq. 13), and thereby diminishes the values of the sub-surface velocities (V) for a given surface velocity (V_0).

The Problem of finding the really Greatest Current-Pressures and Greatest Moments

* It is a remarkable instance of the imperfection of the practical data for this Problem that this is one of the elements involved in doubt.

of the same under these conflicting circumstances seems strictly insoluble, as the relation between V_s and f is *unknown*, but it seems *almost certain* that "a down stream wind is more effective in increasing the sub-surface velocities by its increasing the surface velocity (V_s) than effective in decreasing them in consequence of its raising the axis of the parabola".

The adoption of the value ($f =$ about -5) corresponding to a down-stream half-hurricane causes so great a simplification of the formulæ (14) and (15) and of all others thence derived for Total Current-Pressure, and Moment of the same, (in consequence of its making $d' = 0$) that there would be great advantage in adopting it if it could be shown to be sufficiently approximate.

Now it will be found (by actually constructing the parabola) that a variation in the value assigned to a *down-stream* wind *greater than a half-hurricane* (even if from a half to a whole hurricane $f = -5$ to -10) causes *very little change* (diminution) in the sub-surface velocities for a *given* surface velocity.

Thus the assumption $d' = 0$ causes only a *slight over-estimation* of the values of V (sub-surface velocities), so that the simple formulæ (16) and (17) may be regarded as *good approximations* for the *present problem*.

34. *Current-pressure*.—Our knowledge of current-pressure is wholly empirical; it is approximately represented* by the formula

$$p = k w a \frac{V^2}{2g} \dots\dots\dots (18).$$

$$\left. \begin{array}{l} \text{Total Current-pressure} \\ \text{on an area } a \text{ of } \textit{small} \\ \text{depth, } \dots\dots\dots \end{array} \right\} = k \times \left\{ \begin{array}{l} \text{"heaviness" of fluid} \\ \times \text{ area of cross-section,} \\ \times \text{ height due to velocity,} \end{array} \right\} \dots\dots\dots (18).$$

where k is a quantity depending on the shape and material of the body —at present only obtainable *from experiment*, and on which unfortunately few experiments are available.

[In works on elementary Hydro-dynamics, (*e. g.*, Cape's Course of Mathematics, Vol. II., Art. 546, the value of k for a cylinder is stated to be $k = \frac{1}{2}$ or $\cdot 6$, but this includes only the effect of "impact", and is based on a "theory" of current fluid, which is admitted to be most imperfect.

The best value obtainable for the present problem appears (to the author) to be $k =$ about $\cdot 8$, and for the following reason :—Professor Rankine states* that "the co-efficient k is less for a solid moving in a fluid, than for a fluid moving past the same solid", also that "for a cylinder moving sideways, $k =$ about $\cdot 77$."]

In absence of better data, the author suggests that for the present problem (a current flowing past a fixed cylinder) the value $k = \cdot 8$ should be adopted as being a simple figure and *higher* than $\cdot 77$ as required.

[The Pressure-diagram (for current-pressure), Fig. 3, Plate L, has been constructed from Formula (18). It clearly shows the variation of Current-pressure with the depth; the diminution of Current-pressure on the Pier due to its being 3 feet narrower than the Well is very evident].

* Rankine's Applied Mechanics, Art. 653.

35. Then it may be shown by an easy integration *see* (Art. 71), that if

- V_o = Surface Velocity in feet per second.
- P = Total Current-pressure *parallel to stream* in pounds.
- D = Depth of current in feet.
- A = Area of vertical diametral section *immersed* in square feet.

Then for a Well *tapering only slightly*,

$$P = \frac{8}{15} \cdot kwA \cdot \frac{V_o^2}{2g} \text{ (approximately), } \dots\dots\dots(19).$$

Also in cases where a Pier is placed on a Well of considerably larger diameter, and both are either cylindrical or taper *very slightly*, if

- P' = { Total Current-pressure } on the Pier.
- P'' = { parallel to stream, } on the Well.
- d = Depth of Pier immersed.
- A' = Area of vertical diametral section of *Pier* immersed.
- B = Mean breadth of Well.

$$\lambda = \left(1 - \frac{d^2}{D^2} + \frac{d^4}{D^4}\right) \dots\dots\dots(20).$$

$$\left. \begin{aligned} \text{Then } P' &= kwA' \cdot \frac{V_o^2}{2g} \cdot \lambda, \text{ (approximately),} \\ P'' &= kw \cdot \frac{V_o^2}{2g} \cdot B \left\{ \frac{8}{15}D - \lambda d \right\}, \text{ (approximately),} \\ P &= P' + P'' \end{aligned} \right\} \dots\dots\dots(21).$$

N.B.—If d be small compared with D , the quantity λ may be taken as $\lambda = 1$ approximately: this is an important simplification for numerical calculation.

[The Total Current-pressures on the Pier and Well, *Fig. 1*, are of course represented by the areas of the representative Diagrams (*Fig. 3, Plate XLIV.*) of Current-pressure].

36. *Centre of Current-pressure.*—It is convenient to find this point as, once found, the estimation of the Moment of Current-pressure *about any chosen point whatever* is an easy problem of elementary Statics. It is shown in the Appendix that if

- d_o = Depth of centre of Current-pressure on whole Well.
- d_o' = " " " Pier only.
- d_o'' = " " " Well only.

Then in case of a Well *tapering only slightly*

$$d_o = \frac{5}{16} D, \text{ (approximately)} \dots\dots\dots(22).$$

And in case of a Pier on a Well of considerably larger diameter, neither tapering except very slightly,

$$\left. \begin{aligned} d_o' &= \frac{\mu}{\lambda} \cdot \frac{d}{2}, \text{ (approximately), } \dots \dots \dots \\ d_o'' &= \frac{1}{2} \cdot \frac{\frac{1}{15} D^2 - \mu d^2}{D - \lambda d}, \text{ (approximately), } \dots \dots \dots \end{aligned} \right\} \dots \dots \dots (23).$$

Where $\mu = (1 - \frac{d^2}{D^2} + \frac{1}{3} \frac{d^4}{D^4})$, $\lambda = (1 - \frac{2}{3} \frac{d^2}{D^2} + \frac{1}{5} \frac{d^4}{D^4}) \dots \dots (24).$

Also if d be small compared with D , then $\lambda = 1$, $\mu = 1$ approximately, so that these formulæ become

$$\left. \begin{aligned} d_o' &= \frac{d}{2} \text{ (approximately), } \dots \dots \dots \\ d_o'' &= \frac{5}{16} (D + \frac{15}{8} d) \text{ (approximately), } \dots \dots \dots \end{aligned} \right\} \dots \dots (25).$$

37. *Moment of Current-pressure.*—By elementary Statics, if

- M = Total Moment of Current-pressure in foot-pounds.
- M' = Moment of Current-pressure on Pier only in foot-pounds.
- M'' = Moment of Current-pressure on Well only in foot-pounds.
- H = Assumed depth (below surface of current) of any point chosen as "centre of moments".

Then in case of a Well tapering *only slightly*,

$$M = P \cdot (H - d_o) = kvA \cdot \frac{V_o^3}{2g} \cdot (\frac{8}{15} H - \frac{1}{6} D) \dots \dots \dots (26).$$

And in case of a Pier on a Well of considerably larger diameter neither tapering, *except very slightly*

$$\left. \begin{aligned} M' &= P' \cdot (H - d_o') \\ M'' &= P'' \cdot (H - d_o'') \\ M &= M' + M'' \dots \dots \dots \end{aligned} \right\} \dots \dots \dots (27).$$

Impact of Drift.

38. It has been explained (Art. 9), that it is impossible to calculate the effect of Impact *properly*: an imperfect equivalent—believed however to be sufficient for the purposes of Engineering—was proposed in the substitution of a Mass of floating Drift supposed as caught by the Pier, and exposed to the full force of the current.

- Let A_1 = assumed area (in square feet) of vertical cross section of supposed floating Drift exposed to full force of current.
- V_o = surface velocity.
- P_1 = Total Current-pressure on area A_1 .

Then as the depth of the supposed Drift-Mass is necessarily small (compared with the depth of the river), and as the shape and size of that Mass are *entirely arbitrary*, it is permissible—

- 1°. To assign any arbitrary value to the quantity k in the formula of Art. 34 ; it is convenient to assume $k = 1$.
- 2°. To disregard the variation of velocity in the small depth of the supposed Drift-mass, so that the mean velocity of impinging current may be assumed as sensibly equal to the surface velocity (V_0).

Thus under these premisses, there results for the Total Current-pressure on the Drift-Mass,

$$P_1 = w \cdot A_1 \cdot \frac{V_0^2}{2g}, \dots\dots\dots (28).$$

39. *Moment of Impact.*—Under the same premisses the following will be a *sufficiently approximate* value for the Moment of that Current-pressure about a point H feet below the current surface, viz.,

$$M_1 = P_1 \times H = w \cdot A_1 \cdot \frac{V_0^2}{2g} \cdot H, \dots\dots\dots (29)$$

40. *Horizontal Re-actions.*—The “ Disturbing Forces ” develop Horizontal Re-actions in the subsoil of two kinds—

- 1°. Direct—being the direct normal pressure round the Pier.
- 2°. Tangential—i. e., horizontal friction between the subsoil and base of the Pier.

Let R_n' , R_n'' be the sum of the resolved parts of the Direct Normal Pressures—resolved *parallel* to the stream—against the down-stream and up-stream (semi-cylindric) sides of the Pier respectively, so that

R_n' = Total *up-stream* “ Direct ” Re-action.

R_n'' = Total *down-stream* “ Direct ” Re-action.

F_n = Total horizontal friction.

Then at all times (when there is no motion) this equation must obtain

$$\left. \begin{aligned} &\text{“ Sum of horizontal Re-actions = Sum of Disturbing Forces ”,} \\ &\text{or } R_n' - R_n'' + F_n = P_a + P_m + P + P_1 = \Sigma (P), \end{aligned} \right\} (30).$$

It may be assumed that F_n is very small compared with R_n' , R_n'' : so that neglecting F_n ,

$$R_n' - R_n'' = \Sigma (P), \dots\dots\dots (31).$$

N.B.—The hydrostatic pressure of the Water against the down-stream side of the Pier is omitted from the above enumeration of Resistances, because from the manner in which the experiments on Current-pressure (by which the value of k in formula 18 was determined) were conducted, the resulting formula for Current-pressure expresses only the *excess* of the Current-pressure above the Hydrostatic Pressure against the down-stream side of the Pier.

41. In order to investigate the distribution of, magnitude of, and posi-

tion of Centre of Pressure of these Re-actions, consider separately the cases

- 1°. Of a Pier not under the action of Lateral Disturbing Forces.
- 2°. Of a Pier under the action of Lateral Disturbing Force.

1°. *Pier not under Lateral Disturbing Forces.*—In this case it is evident that $R_H' - R_H'' = 0$, (for the Disturbing Forces P are zero) and $R_H' = R_H''$, i. e., the Re-actions of the soil are equal up and down-stream.

[Observing that there is a hydrostatic pressure of D feet of water (being the depth of the current) on the surface of the soil, then if σ = specific gravity of the soil, the "head of water" is equivalent to a "head" of $D \div \sigma$ feet of soil, and according to the usually received theory of loose earth (or quicksand) pressure, the intensity of its pressure against the Masonry is simply proportional to the depth below a plane $D \div \sigma$ feet above the actual surface of the soil, or in fact follows the law of distribution of fluid pressure, so that its "Centre of Pressure" would be the same as that of ordinary fluid pressure against a submerged vertical cylinder whose top and bottom are $D \div \sigma$ and $(D \div \sigma + h)$ feet below the imaginary fluid surface.

It is shown (in the Appendix) that the height of the Centre of pressure above the base of the Pier is, if $D' = D \div \sigma$,

$$h_o = \frac{h}{3} \cdot \frac{3 D' + h}{2 D' + h}, \text{ or } \frac{h}{3} \left(1 + \frac{D'}{2 D' + h} \right) \dots\dots\dots (32)$$

It is worth noting that from Eq. (32), h_o is always $> \frac{h}{3} < \frac{h}{2}$; or $h_o = \frac{h}{3}$ when $D' = 0$, i. e., when there is "no head", also h_o increases with the "head" (D) approaching to the limit $\frac{h}{2}$ when the "head" (D') is very large].

2°. *Pier under lateral Forces.*—There are no experimental data for determining the distribution of, actual magnitude of, and centres of pressure of the horizontal Re-actions (R_H', R_H'') up-and down-stream, (which determination is requisite to the proper solution of the problem): still some useful generalizations may be drawn.

Firstly, so long as there is no actual motion of the Pier, it is obvious that the Equation (31) must hold true,

$$\therefore R_H' > \text{Sum of Disturbing Forces, } \Sigma (P), \dots\dots\dots (33)$$

It seems most probable that the effect of the Disturbing Forces on the magnitude and distribution of the horizontal Re-actions is as follows:—

- 1°. To diminish the pressure of the soil on the near (or up-stream) side, and to press the Pier more against the soil on the far (down-stream side), i. e., to diminish R_H'' and increase R_H' .

- 2°. To alter the distribution of pressure of R_H' , R_H'' in opposite directions, viz.,
- (a). On the near (up-stream) side—diminishing the intensity of pressure near the surface, and increasing it towards the base, and therefore of course *depressing* the “centre” of pressure of R_H'' .
 - (b). On the far (down-stream) side—diminishing the intensity of pressure near the base, and increasing it towards the surface; and therefore of course *raising* the “centre” of pressure of R_H' .

These results may be briefly expressed—

“The Disturbing Forces raise and depress the Resultants” of the up-stream } (34).
and down-stream horizontal Re-actions”, }

These results are very important as the raising of the Resultant R_H' increases its Moment (of Stability) and depressing R_H'' decreases its Moment (of Instability). Both actions are therefore *conducive to Stability*.

[It will be seen hereafter, Art. 49, that Stability of Rotation depends chiefly on the power of the soil to bear this alteration of the original distribution of pressure.

There is good reason to suppose that though the *first* action of the Disturbing Forces may be to *decrease* R_H'' , their *ultimate* effect must be to *increase* R_H'' . It will be shown that the *principal* element of Stability (of rotation) is the Moment of Stability of the up-stream horizontal Re-action (R_H')—which may be increased

- 1°. By raising its Resultant (so as to increase its leverage).
- 2°. By increasing its magnitude (R_H').

But the nature of the soil will not admit of increase of the leverage by raising of the Resultant (which involves increased intensity of pressure towards the Surface) beyond a certain limit, so that further increase of Moment of Stability of R_H' must be due to increase in the actual magnitude of R_H' .

But since $R_H' - R_H'' = \text{Sum of Disturbing Forces}$, it is obvious that for a *given* Disturbing Force an increase in R_H' is accompanied by an *equal* increase in R_H''].

42. The above general results are probably all that can be *certainly* affirmed as to the distribution of, magnitude of, and position of the Resultant of the Horizontal Re-actions R_H' , R_H'' in absence of experimental evidence as to the nature of the subsoil resistance.

[It will be shown in Art. 53 how on certain hypotheses as to the nature of that resistance, definite numerical results can be obtained].

LATERAL STABILITY—STABILITY OF SLIDING.

43. It is clearly essential to the use of the Pier that it should not slide away (as a whole) down-stream. It appears certain that in some of the great rivers with sandy beds, there is motion (of the water at any rate) going on for a considerable depth below the visible “bed” of the stream.

[This is an inference from the observed fact that, though the very large quantity of water withdrawn for canals from the large rivers (such as the Ganges and Jumna)

greatly reduce the quantity of water in the stream for some miles below the sea beach, it makes no perceptible difference in the position of a *Flume* or *weir* set out from the main beach.

Whether the stones lay on the shore, or the particles also partake of this motion, depends on the velocity of the water, and on the weight of the particles.

The author concludes that for the purpose of the present problem, if "surface of sand" is the bed among the settling-particles, it should be considered the normal bed of the stream.

It appears from the account given, that Flume *sh* will be sunk well below this "normal bed" — *i. e.* that the failure of such Flume as cannot be sunk well below the surface of the main bed, however slow among the settling-particles is certain, and will take place by *sh* falling as a whole below-stream.

It will be assumed therefore that a Flume will in practice be sunk well below this level.

The Total Force which tends to cause sliding is simply the sum of the "Disturbing Forces": the Total Resistance to sliding is simply the algebraic sum of the Horizontal Reactions R_1, R_2, \dots so that at an instant when motion is not actually going on R_1, R_2, \dots must remain.

$$\text{"Total Disturbing Force" = Total Resistance to sliding.}$$

But there is a natural limit to the latter quantity, Resistance, viz. the "greatest intensity of pressure which the soil can bear with safety at a point". There is an experimental *coefficient* in this point. Without this *practical* factor it is simply impossible to estimate numerically the "Working Resistance to sliding" — meaning thereby the "Greatest Resistance" sliding which the soil can supply with safety.

SEC. IV.—ROTARY STABILITY: STABILITY OF ROTATION.

44. Well-foundations as actually constructed appear to have failed *generally* by "tilting over", *i. e.* by want of "Stability of rotation", so that this Problem assumes particular practical importance.

In order that the Pier may possess "Rotary Stability" as a whole, is necessary

(1). That the external forces of all sorts (including all Re-actions) should be so that in the *normal* position

- * The algebraic sum of their Moments about any point = 0, or(3)
- * The Sum of Moments of Stability = Sum of Moments of Instability,(3)

(2). Also that the Re-actions should be of such *character* that on the Pier undergoing a *very small* (hypothetic, not actual) displacement (tilting).—

“The Resultant Moment) of *all* the external Forces (including *all* Re-actions) should “*tend to restore* the Pier to its normal position”, *i. e.*, “Sum of Moments of Stability > sum of Moments of Instability”,(36).

These conditions may be called.

- (1). The condition of temporary equilibrium.
- (2). The condition of permanent (rotary) Stability.

45. There is one peculiar difficulty in this Problem (of Rotary Stability) in the present case of quicksand foundations, *viz.*, that the Re-actions of the soil alluded to are of very different *character* to the ordinary Re-actions of solid or sensibly rigid supports (*e. g.*, rock foundations): the latter alone are met with in the usual Problems in Structures, and are alone familiar.

[There is little difficulty in estimating the Moment of Stability of a *solid Structure* placed on a *rigid support*; when no lateral (disturbing) Forces are applied, such a Structure presses *all over its base*, so that the Re-action also is distributed over the base, but the instant the Structure is *tilted ever so slightly* by lateral forces, the distributed Re-actions are immediately concentrated into a *single Re-action* passing through the heel (or point of rotation), so that by taking moments about any chosen point *on this line*, the moment of the Re-action is zero and does not therefore appear in the result, so that *no attention need be paid to it*. It is in fact commonly simply ignored in ordinary Text-books: the above is however the *sole justification* of thus disregarding the Re-action. It is otherwise with the Re-actions in the present problem: they do not become so concentrated into a single Resultant upon a *slight* tilting of the Structure, so that there is no point about which the Moment of these Re-actions obviously vanishes, and they *cannot be disregarded* in estimating the Moment of Stability].

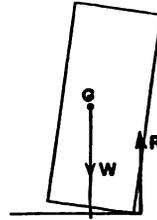

In fact the question of “STABILITY of rotation” in the present case resembles that of the *Stability of Ships* to the extent that the Re-actions are distributed pressures which *do not greatly vary* for a slight displacement (tilting over).

46. It ought to be sufficiently obvious that the Equation of Moments (Eq. 35) must be true *for any point whatever*, so that it is a matter of indifference (theoretically) what point be chosen as “Centre” for estimating Moments: it may make great difference in *convenience* of calculation what point is chosen, but the *result* will be the same—

e. g., in Structures on solid (sensibly rigid) supports, it is *convenient* to choose some

point on the Resultant Reaction (after the Structure has undergone a slight displacement), simply because the Moment of the Reaction does not appear in consequence in the result—a matter of some convenience for saving calculation—but the choice of any other point would eventually lead to the same result.

But about whatever point the Moments be estimated it is *essential* to include in the Equation of Moments all Re-actions whose Resultants do not pass through the chosen point.

[No difficulty is felt about this in the ordinary problem of Structures on rigid supports because (as explained) the "centre of Moments" can be so chosen as to render consideration of the Re-actions unnecessary. There is in the present problem also no doubt some point through which the Resultants of some of the Re-actions pass, but as the position of this point is not known *a priori* it cannot be chosen.]

It is on the whole perhaps *most convenient* to choose the extreme lower (down-stream) point of the base as "Centre of Moments", because all "arms of levers" are thus *positive*.

[A simple consideration will now show the necessity of including *all* Re-actions in the Equations of Moments.

With increased depth of sinking, the arm of lever of the Disturbing Forces, increases, and therefore also their Moment (about chosen point), which is of course the Moment of Instability—but the arm of leverage of the Weight of the Pier remains constant (being simply the radius of the Pier's base) so that its Moment which is a Moment of Stability remains constant. If the Re-actions be *disregarded*, the following absurd result necessarily follows:

"Increased depth of sinking is attended with decrease of rotary Stability"].

47. *Moment of Instability*.—This is the sum of the Moments of the Disturbing Forces and of some of the Re-actions.

- | | |
|-----------------------------|--|
| (1). Wind on Girders. | (5). Upward Water-pressure. |
| (2). Wind on Piers. | (6). Direct Vertical Re-action of soil. |
| (3). Current on Drift Mass. | (7). Vertical Friction. |
| (4). Current on Piers. | (8). Lateral Resistance of soil on up-stream side. |

Moment of Stability.—This is the sum of the Moments of the Weights and of one Re-action.

- | | |
|--------------------------------|---|
| (9). Weight of superstructure. | (11). Lateral Re-action of soil against down-stream side. |
| (10). Weight of pier. | |

Formulae have already been given for the Moments of (1), (2), (3), (4); those of (5), (9), (10) are also readily calculable: but the *experimental data* are entirely wanting for properly calculating the Moments of (6), (7), (8), (11), so that it is impossible to present any *certain numerical estimate* of the (Rotary) Stability or Instability of the Piers, (as it has been explained to be essential to include (6), (7), (8), (11) in the Equation of Moments). Some useful generalizations may however be made.

48. Separating the Moments of vertical from those of horizontal forces, and observing that by Art. 12,

$$\left. \begin{array}{l} \text{Sum of vertical forces pro-} \\ \text{ducing Instability, viz.,} \\ \text{Nos. (5), (6), (7),} \end{array} \right\} = \left\{ \begin{array}{l} \text{Sum of vertical forces pro-} \\ \text{ducing Stability, viz.,} \\ \text{Nos. (9) and (10),} \end{array} \right\} \dots\dots\dots (37).$$

but that the arms of leverage of the Resultants of the former are less than those of the latter (being in the latter case simply the radius of the base, and in the former some *smaller* quantity), it follows that—

“The Resultant Moment of *all* the Vertical Forces (including Weight and Reactions) is always a Moment of Stability”.

Increased depth of sinking does not affect the arms of leverage of Nos. (5), (9), (10), and it seems (to the author) *extremely probable* that it does not affect the arm of leverage of the remaining vertical forces Nos. (6) and (7). Hence (Eq. 37), it may be inferred with a high degree of probability that—

“The Resultant Moment of *all* the Vertical Forces is always a Moment of Stability, and *not affected* in amount by increased depth of sinking”,... } (38.)

49. Next considering the horizontal forces—it is clear that—

“Increased depth of sinking increases the Moments of both kinds (Stability and Instability) of the horizontal forces”.

Observing that the sum of the Disturbing Forces, (1), (2), (3), (4) is unaffected by increased depth of sinking, also that the Resultant up-stream Lateral Re-action of the soil, *i.e.*, $R_H' - R_H''$ (the excess of (11) over (8) is also unaffected by increased depth of sinking, (being equal to the sum of the Disturbing Forces), it follows that the Moment of Instability of the Disturbing Forces is *increased* by increased depth of sinking simply by increased arm of leverage, but on the other hand that the Resultant Moment of Stability developable (though not necessarily developed) from the Lateral Re-action of the soil is increased *in a still higher ratio* than the former, in consequence both of increase in the Total Re-actions developable from the increased extent of soil (and that of greater compactness) in contact with masonry, and also of the (favorable) change, *see* Result (34)—in the arms of leverage of the Re-actions. These Results may be briefly expressed,

“Increased sinking increases the Moments of Instability of the Disturbing Forces, and also the available Resultant Moment of Stability of the Horizontal Re-actions—the latter in a higher ratio”, } (39).

[Both these Re-actions (both up-stream and down-stream), be it observed, are *simultaneously* necessary to Stability of Rotation].

This last is a *most important* Result, for in consequence of all the Ver-

tical Re-actions having been proved to be conducive to *Instability* (I (3) and (6)), it is probable that the "Resultant Moment" of Vertical Forces (which has been shown to be a Moment of Stability *not of great magnitude*, and as it has been explained that it (most probably) cannot be increased by increased depth of sinking, it follows that

"The Weight of the Pier is in quicksand comparatively unimportant in producing STABILITY (of rotation), also that

"Stability (of rotation) of Piers in quicksand is almost entirely due to the Lateral Resistance of the soil", or in other words

"Stability of Rotation can *only* be secured by sinking to a depth at which the required Lateral Resistance can be developed,"

50. The utmost that it seems possible to do *with certainty* in the of *numerical estimation* of Stability of Rotation is to calculate the Moment of Instability Nos. 1 to 5, and of Stability Nos. 9 and 10. Their reference will be a Moment of Instability. It can then only be left to the practical Engineer to judge (empirically) whether the requisite Moment of Stability No. 11 is, or is not developable from the particular sub-

51. But by making some hypotheses (guided by knowledge of soil) as to the nature of the resistance of the soil, more definite numerical results may of course be obtained. Although the results are of course *that extent* hypothetical, still if the hypotheses are well chosen, they will be *some* guide to the practical Engineer, better than no guide at

[The usual hypothesis in works* on Applied Mechanics as to the nature of resistance of the soil is that the soil is *capable* of bearing and therefore of yielding a pressure of "uniformly-varying" intensity (*i. e.*, varying as the distance from a horizontal axis) provided that there be *pressure* over all parts of the surface pressed at equal or unequal intensities, and not greater than the greatest internal pressure (usually called "conjugate pressure") due to frictional stability of the particles].

The course proposed is *by assigning some probable manner of distribution* of the various Re-actions to deduce the numerical values of Total Horizontal Re-actions required from the soil, and of the mean maximum intensities of the same. It will then rest for the practical Engineer to consider whether the particular soil can or cannot yield the *intensity of pressure* indicated as necessary.

[*N.B.*—The greatest intensity of pressure which the soil can safely bear should of course be one of the *practical* data to be furnished with a Problem of this sort.)

It will be convenient to consider the Moments of the Vertical and Horizontal Forces separately.

* See Rankine's Applied Mechanics, Arts. 187, 198, 199.

$$\begin{aligned}
 M_v &= \text{Moment of Weight} - \text{Moment of Water-pressure} - \text{Moment of Vertical Re-actions of soil,} \\
 &= W \cdot r - W' r - (R + F) \frac{r}{2} \\
 &= (W - W') r - (W - W') \frac{r}{2}. \\
 &= (W - W') \frac{r}{2} \dots\dots\dots(44).
 \end{aligned}$$

It is worth noting that had the Pier been resting on a *rigid* support (e.g., rock-foundation), the Moment of Stability of Vertical Forces would have been simply $W r$, *i. e.*, the Moment of the Weight of the Pier—and that in this problem, the Water pressure on the base reduces the “effective Weight” of the Pier to $(W - W')$ —see Art. 16, and that the peculiar *distribution* of the Re-actions reduces the leverage from r to $\frac{1}{2} r$, so that the Resultant Moment is only $\frac{1}{2} (W - W') r$. This bears out the remark that the Pier’s mere Weight must not be relied on for producing Stability of rotation, *see* Result (40).

53. *Moment of Horizontal Forces.*—A rough approximation may now be made to the magnitudes of the Total up-and down-stream Horizontal Re-actions (R_H' , R_H'') which the soil must be capable of supplying against the Pier—by making some hypothesis as to the *distribution* of those Resistances.

It has been explained (Art. 41, Result 34) that the effect of the Disturbing Forces on these Re-actions was to alter the *distribution* of both of them, raising the Resultant (R_H') of up-stream Re-action and depressing the Resultant (R_H'') of down-stream Re-action. Now it seems probable that *the natural limit* to this action will be such an alteration in the *distribution* of the pressure that—

- 1°. On the up-stream side—the soil shall *just cease to press* against the Masonry at the surface (of the soil).
- 2°. On the down-stream side,—the soil shall *press uniformly*.

Assuming that the vertical distribution of pressure is still “uniformly-varying” in the former case, the effect would be

1°. To depress the Resultant (R_H'') of down-stream Horizontal Re-action to a height of $\frac{1}{2} \times$ depth (of sinking) above the base, (by the usual rules of uniformly-varying pressure).

2°. To raise the Resultant (R_H') of up-stream Horizontal Re-action to a height of $\frac{1}{2} \times$ depth (of sinking) above the base.

[The exact variations of pressure proposed are of course hypothetical, but they are of the character indicated as *certain* in the generalizations in Art. (41)].

Let h = depth of sinking.

$\Sigma(P)$ = Sum of Disturbing Forces.

M_v = Resultant Moment (of Stability) of *all* Vertical Forces.

M_H = Sum of Moments (of Instability) of Disturbing Forces.

M_H' = Moment (of Stability) of up-stream Horizontal Re-action (R_H').

M_H'' = Moment (of Instability) of down-stream Horizontal Re-action (R_H'').

Then by the Results 1° and 2° of above assumptions—

$$M_H' = R_H' \times \frac{h}{2} \dots\dots\dots (45).$$

$$M_H'' = R_H'' \times \frac{h}{8} \dots\dots\dots (46).$$

Hence from the Equation of Moments

$$R_H' \times \frac{h}{2} - R_H'' \cdot \frac{h}{8} = M_H - M_V \dots\dots\dots (47).$$

Also from the condition of equality among the horizontal forces

$$R_H' - R_H'' = \Sigma (P) \dots\dots\dots (48).$$

54. *Total Horizontal Re-actions* (R_H' , R_H'').—As M_H , M_V , P are known quantities, the two quantities R_H' , R_H'' the up- and down-stream Horizontal Re-actions can be calculated from these two equations. Thus,

$$\left. \begin{aligned} R_H' &= 6 \left(\frac{M_H - M_V}{h} \right) - 2 \Sigma (P) \\ R_H'' &= 6 \left(\frac{M_H - M_V}{h} \right) - 3 \Sigma (P) \end{aligned} \right\} \dots\dots\dots (49).$$

55. *Intensity of Horizontal Re-actions*.—On the foregoing assumptions as to the distribution of pressure, it follows that if

$$\left. \begin{aligned} p_o' &= \text{Mean intensity of up-stream horizontal Re-action,} \\ p_o'' &= \text{'' '' down-stream '' ''} \\ p'' &= \text{Maximum intensity of down-stream ''} \\ h &= \text{depth of sinking} \dots\dots\dots \end{aligned} \right\} \text{in pounds per square foot.}$$

Then (by the pressure-distribution assumed in Art. 53, see also Art. 56).

$$\frac{R_H'}{h} = \text{Intensity of } R_H' \text{ per vertical foot} \dots\dots\dots (50).$$

$$\frac{R_H''}{h} = \text{Mean Intensity of } R_H'' \text{ per vertical foot} \dots\dots\dots (51).$$

$$2 \frac{R_H''}{h} = \text{Maximum Intensity of } R_H'' \text{ per vertical foot} \dots\dots\dots (52).$$

$$\therefore \left. \begin{aligned} p_o' &= \frac{R_H'}{hr} \dots \\ p_o'' &= \frac{R_H''}{hr} \dots \\ p'' &= \frac{2R_H''}{hr} \dots \end{aligned} \right\} \dots\dots\dots (53).$$

These quantities, (p_o' , p''), the actual greatest intensities of pressure of the Masonry on the subsoil produced by the Disturbing Forces (under the assumed distribution of pressure) are the final quantities proposed for calculation in Art. 51. These having been calculated it rests with the practical Engineer to decide whether any particular soil can or cannot bear them. [This of course can only be ascertained by experiment].

56. *Explanation of Results (50) to (53)*.—Results (50) and (51) seem obvious. Result (52) follows from (51), because the distribution of R_H'' had been assumed as

“uniformly-varying”, and its intensity at soil-surface zero. Now the maximum intensity is known in such a case to be twice the mean-intensity: hence Result (53).

Results (50) to (52) give the values of the *sum* of the resolved parts *parallel to the stream* of the Normal Pressures on a vertical semi-cylinder of one foot in height. The intensity of Normal Pressure causing that Total Pressure (50 to 52) *in one direction* is known* to be (53).

Example.

57. The following numerical Example is that of a Pier for the Bridge over the Rámangá, see Art. 2.

Fig. 1 shows a vertical section through the Pier's centre of gravity.

Fig. 2 is a “Velocity-Diagram”, showing the *variation* of subsurface-velocity throughout the depth calculated by Eq. (16).

Fig. 3 is a “Pressure-Diagram”. The distribution of the Horizontal Pressures (of all kinds) is shown by the abscissæ of the figure in thin lines: the Total or Resultant Pressures of all kinds (both vertical and horizontal) are shown by thick lines, and are drawn through the respective Centres of Pressure.

The Vertical Force representative lines necessarily overlap Fig. 1.

The use of *several* scales in this Diagram was unavoidable owing to the very great difference in the Forces, thus the scales are as follows:—

For Distribution of Disturbing Forces,	2,000 lbs. to an inch.
„ Total or Resultant of Disturbing Forces,....	10,000 „ „
„ Distribution of Horizontal Subsoil Re-actions,	50,000 „ „
„ Total or Resultant Horizontal Subsoil Re-actions,	} 500,000 „ „
„ Vertical Forces,	

Tables I. and II. contain details† of the calculation of all the quantities indicated in this Paper, ending with the following.—

Total Disturbing Force,	$\Sigma (P) = 138,710$ lbs.
Moment (of Instability) of Disturbing Forces,	$M_H = 11,072,400$ ft. lbs.
Moment (of Stability) of <i>all</i> Vertical Forces,	$M_V = 4,197,600$ „

Hence are calculated by Eq. (49), Art. 54, the *final* quantities,

Total Horizontal subsoil Re-actions,	{ up-stream, $R_H' = 1,372,500$ lbs.
	{ down-stream, $R_H'' = 1,333,800$ „

also by Eq. (53), Art. 55,

Mean intensity of <i>up-stream</i> horizontal subsoil Re-action,	} $p' = 6,860$ lbs. per sq. ft.
Greatest intensity of <i>down-stream</i> horizontal subsoil Re-action at foot of Well,	
	} $p'' = 12,840$ lbs. per sq. ft.

Approximate calculations were considered sufficiently accurate for this Problem: thus in Formulæ 20, 21, 23, 24, λ , μ have each been taken as = 1, also $2g = 64.4 = 64$ nearly. The Results are all stated in round numbers. The numerical work has been carefully checked.

[It rests solely with the Resident Engineers to decide whether the soil can or cannot bear these intensities of pressure safely, and the *Stability* depends solely on this].

* Rankine's Applied Mechanics, Art. 179.

† With list of references to all the formulæ required.

TABLE I.—VERTICAL FORCES.

	Height in ft.	Volume in c. ft.	Weight in lbs.	Lever arm in feet	Moments in foot-pounds.	Reference to Text.
Girders,	44,800	Art. 16.
18 feet Pier to Flood-level, ...	112.5	$\pi \times (\frac{13}{2})^2 \times 10.85$	164,300	Art. 16.
18 feet Pier (in water), ...	50	$\pi \times (\frac{13}{2})^2 \times 17$	118,900	Art. 16.
16 feet Wall (in water), ...	50	$\pi \times (\frac{15}{2})^2 \times 72$	727,000	Art. 16.
∴ Resultant of Weight and Water-pressure,		} i. e., (W - W') =		8	8,395,200	Art. 16.
∴ Total Vertical Reaction of soil, i. e., (R + F) =				4	4,197,600	Art. 19, 52, Eq. (2), (48).
∴ Result Moment (of Stability) of all Vertical Forces, i. e., M _V =					4,197,600	Art. 52, Eq. 44.

TABLE II.—DISTURBING FORCES.

Force.	Pressure-Intensity in Lbs. per sq. foot.	Area in square feet.	Total Pressure in Lbs.	Leverage in feet.	Moments in foot-pounds.	Reference to Text.
P _G { on Girders, Wind	40	817	12,680	102½	1,297,700	Arts. 23, 24, 26, 46. Eq. (8), (9), (11).
P _M { on Pier,	½ × 40	121½	2,430	94½	229,400	Arts. 23, 24, 26, 46. Eq. (9), (12).
P _I { on Drift-Mass,	16 ² 62.5 × 64½	100	25,000	89	2,225,000	Arts. 38, 39, 46. Eq. (28), (29).
P _P { on 18 feet Pier,	16 ² 62.5 × 64½	17 × 18	44,200	89 - ½ × 17	8,566,700	Arts. 34, 35, 37, 46. Eq. (21), (26), (27).
P _W { on 16 ft. Well,	16 ² 62.5 × 64½	(⁹ / ₁₅ × 64 - 17) × 16	54,400	89 - ¹ / ₁₆ · (64 + ¹⁵ / ₉ × 17)	8,753,600	Arts. 34, 35, 37, 46. Eq. (21), (25), (27).
∴ Total Disturbing Force, i. e., Σ (P) =			186,710			
∴ Resultant (up-stream) Horizontal } Re-action of soil, } i. e., R _H ' - R _H ' =			186,710			Arts. 40, 53. Eq. (31), (48).
∴ Total Moment (of Instability) of Disturbing Forces, i. e., M _H =					11,072,400	Art. 46.

Fig. 1.
**VERTICAL SECTION
 OF
 PIER AND WELL.**

Scale, 20 feet to an inch.

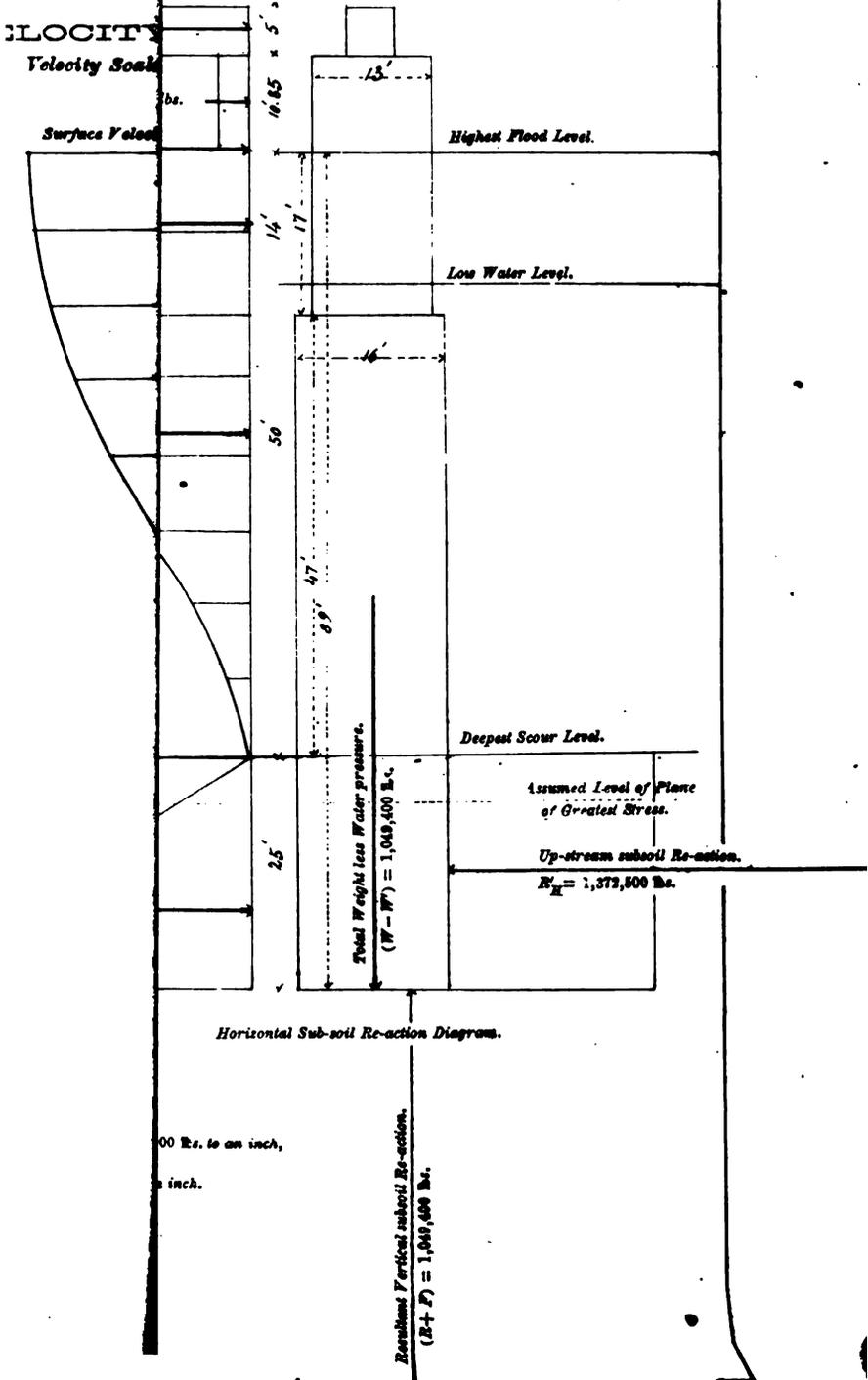



SEC. V.—TRANSVERSE STRENGTH.

58. This is a question *entirely distinct* from that of STABILITY, and requiring distinct treatment.

The general effect of the Disturbing Forces is to produce two distinct Strains and Stresses at every cross-section, viz., (1), Shearing; (2), Longitudinal (in the present case vertical).

[It is considered that a solid Masonry Structure is necessarily able to bear the Shearing Force, so that the only question requiring treatment is that of the Longitudinal Stress produced].

59. The Weight of the Superstructure and upper courses of masonry produce in a symmetrical Pier (the usual kind) an *approximately uniform pressure* all over each horizontal course of masonry, *when the Pier is not under the action of the Disturbing Forces.*

It may be said in a general manner that the effect of the Disturbing Forces is solely to *alter the distribution* of that pressure, so as to produce a *varying pressure*—least intense on the near (up-stream) side, and most intense on the far or down-stream side.

This *variation* of pressure may *increase* (with increase of the Disturbing Forces) to such an extent as wholly to relieve the *pressure* on the near side, or even produce *tension* on that side. The material will fail if either of the two stresses, viz., tension on the near side, or pressure on the far side *exceed* the limits of resistance to tension and crushing of the material.

60. The Problem admits of consideration from two aspects,

(1). To ascertain the actual Longitudinal Stress produced at any Cross-section in a given Pier by a given Disturbing Force.

(2). To ascertain the diameter of Pier required to bear with safety the greatest Longitudinal Stress produced by a given Disturbing Force.

It is supposed (by the author) that Piers would in practice be designed from considerations other than those of Transverse Strength, *e. g.*, from considerations of Stability, so that the usual problem would be the former (1). Although somewhat more difficult than the latter, it will accordingly be considered.

[It is *assumed* by general consent* of the profession that the varying Longitudinal Strain produced over a Cross-section by Transverse Strain is a uniformly-varying Strain, also that within elastic limit Stress varies as Strain.

These assumptions are necessary* to the formulæ (54) of Art. 65].

* Rankine's Applied Mechanics, Art. 306.

[The method adopted by the author is *in principle* the same as that adopted by Mr. E. Bell in the Report referred to in Art. 6.

The author's *numerical* results in the Example chosen (Art. 69) differ from those of Mr. Bell probably chiefly in consequence of the different estimates of sub-surface-velocity adopted, *see* Art. 28.]

61. *Plane of greatest Stress*.—Remembering that Indian Well-foundations consist in general of a Pier placed on a somewhat larger Well neither of which taper much, it follows that—

(1). The *available* power of Resistance to the Longitudinal Stress produced by the Disturbing Forces is approximately *the same* at *every* horizontal section of the Well.

(2). The Longitudinal Stress actually produced at any horizontal section (of the Well) will depend entirely on the actual Bending Moment of the External Horizontal Forces (including Disturbing Forces and Re-actions).

Now the Bending Moment of the Disturbing Forces clearly increases in magnitude from the top of the Well downwards; also under any conceivable distribution of the subsoil Re-actions (Arts. 41, 53) *which will produce* STABILITY OF ROTATION, it seems (to the author) essential that within a *short* depth of the current bed there should be *considerable* "horizontal up-stream subsoil Re-action", and that it should rapidly increase with the depth: the Moment of such Re-action will *oppose* that of the Disturbing Forces. Hence the following important Corollaries—

1°. "The Bending Moment of *all* the Horizontal Forces (whether Disturbing or Re-actional) increases from the top of the Well downwards, and attains a maximum at *some short distance below* the current-bed, and the "Greatest Longitudinal Stress" occurs at that plane".

2°. Inasmuch as the safety of the Structure depends solely on this "Greatest Stress", it is quite unnecessary (as a practical question) to consider any other.

[This is an important saving in calculation].

It would be important to discover the exact position of this plane of greatest Stress, but this cannot be done without assigning the precise distribution of the Horizontal Re-actions. Under the uncertainty attending any hypothetical assignment of this distribution, it does not seem (to the author) worth while to introduce so complex an investigation. It seems (to the author) most probable that the "plane of greatest Stress" cannot lie at a *depth greater than* one-fifth of the depth of sinking—having regard to the necessity of STABILITY OF ROTATION.

It will be assumed therefore in the remainder of this investigation that the plane of greatest Stress lies at this depth (one-fifth of depth of sinking).

62. *Resistance of Masonry to direct Strain.*—Those materials whose Resistance to tearing and crushing are equal are in general best fitted to resist Transverse Strain.

The available Tenacity of “Brick Masonry” is clearly the *least* of the following quantities—

- 1°. Tenacity of the Brick.
- 2°. Tenacity of the Mortar or Cement.
- 3°. Adhesion of the Mortar or Cement to the Brick.

The available resistance of “Brick Masonry” to crushing is clearly the lesser of the following quantities—

- 4°. Resistance to crushing of the Brick.
- 5°. Resistance to crushing of the Mortar or Cement.

The “available Tenacity” of *ordinary* “Brick Masonry” is generally far inferior to its “available resistance to Crushing”. In fact English *practice* in designing Masonry Structures set in Mortar is *not to depend at all** on the Tenacity of the mortar.

An Extract from a Memo. by B. Leslie, Esq., bearing on the Strength of Mortar used in the Well-foundations of the Oudh and Rohilkhand Railway is appended.

“My own experience of brickwork in India is that as a rule, it is superior to the average of brickwork in England. This is chiefly owing to the excellent quality of the bricks and the use of soorkee instead of sand for making mortar, by which the strength and tenacity of the mortar may become equal to that of the bricks themselves.

In considering the tenacity of brickwork in a vertical direction, which is necessary, as the lateral strains resolve themselves into vertical strains at the plane of fracture, we are to a very great extent dependent on the quality of the workmanship, and the supervision maintained during construction. In building up new brickwork upon that which has been built for some time, it is essential to remove two or three courses to arrive at “green work” to which the mortar will adhere, and even then, as there is no vertical “bond”, we are entirely dependent upon the adhesion of the mortar for vertical tenacity”.

An Extract from some “General Observations” on the Well-foundations in the same Railway by E. Byrne, Esq., Resident Engineer at Lucknow, bearing on the same point (*viz.*, Strength of Mortar used in the Well-foundations) is appended.

“The tenacity of Mortar * * * * may as a high figure be taken at 50 lbs. per superficial foot. 300 lbs. attainable by the use of certain cements is not a thing of ordinary practice; and if a floating mass carried down by unexpected floods should bear upon new, and hurriedly constructed brickwork, the shock received may quickly prove that

* Rankine's Civil Engineering, Art. 263.

the mortar used in putting it together had not attained a tenacity of even 20 lbs. per superficial foot.

Rough treatment to brickwork should as much as possible be avoided, for disturbance of any kind, is prejudicial to the setting of mortar, and its proper adherence to work which it is intended to keep together.

The oscillating manner in which wells sometimes go down is attended with risk; for if heeling over be excessive, and when the mortar is still fresh, force be employed to regain position, fracture may ensue."

In absence of good data, and after such conflicting statements there appears (to the author) to be no reason to depart from established English practice for Masonry simply set in Mortar.

[Admitting the Mortar to be even of superior quality, considerable allowance must be made for the rough treatment a Well is exposed to in the act of sinking, as being likely to impair the tenacity of its Mortar, *vide* Mr. Byrne's opinion].

63. But some Indian Well-foundations differ in an *important* point from *ordinary* masonry in being bonded together vertically by iron ties connecting horizontal curbs. The introduction of these iron Ties must so greatly increase the "available Tenacity" of the Masonry (as a whole) that this Tenacity will become a very important element of Transverse Strength.

Practical Remark.—It seems to the author that the best result would be obtained (in future structures) by placing a sufficient number of vertical Iron Ties on the side likely to be in Tension (the up-stream side)—especially where the Tension would be most severe, *i. e.*, for some distance above and below the level of greatest scour—to make the "available vertical Tenacity" of the Masonry approximately the same as its available Resistance to Crushing.

64. *Wells classed.*—Indian Well-foundations appear therefore to be divisible into two classes as regards the investigation of their **TRANSVERSE STRENGTH**, *viz.*,

CASE I.—Tied vertically with iron-ties—Tenacity approximately equal to Crushing Strength.

CASE II.—Simply set in Mortar. Tenacity to be disregarded.

65. Formulæ for Greatest and Least Stress-intensities (p' , p'') at plane of Greatest Stress.

CASE I. *Well with vertical iron ties.*—Assuming as in Art. 64, that the Ties are applied so as to make the *available* Tearing and Crushing Strength of the Masonry approximately equal—

Practical Conclusion.—The Crushing Strength of good masonry is known to be about 1,000 lbs. per square inch. It follows that—

It may be shown* that if

W = Total Weight above any Cross-section AB.

A = Area of that section.

M_H = Bending Moment (of Horizontal Forces) at that section.

a, β = Distances of centre of gravity of that cross-section from the down-stream and up-stream sides of the cross-section.

I_o = Moment of inertia of the cross-section about an axis across the stream through its centre of gravity.

p', p_o, p'' = Greatest, Mean, and Least intensities of Stress over the cross-section.

$$\left. \begin{aligned} \text{Then, } p' &= \frac{W}{A} + \frac{M_H}{I_o} \cdot a, \text{ (pressure).....} \\ p_o &= \frac{W}{A}, \text{ (pressure).....} \\ p'' &= \frac{W}{A} - \frac{M_H}{I_o} \cdot \beta, \left\{ \begin{array}{l} \text{pressure or tension according as} \\ \frac{W}{A} > < \frac{M_H}{I_o} \cdot \beta \text{} \end{array} \right\} \end{aligned} \right\} \text{.....(54).}$$

CASE. II. *Masonry simply set in Mortar*.—As (by hypothesis) the Tenacity of the Mortar is not to be relied on, it follows that there should (for safety) be some *pressure* over every part of the Cross-section, so that the Longitudinal Stress at that section should be all of one kind (viz., pressure).

Now it may be proved* that *in this case* (i. e., when the Stress is all pressure), “the Greatest and Least intensities of Stress are the same for all material (which is capable of bearing a uniformly-varying Strain), within the Elastic limit of Crushing Strain”, and may therefore be found by the same formulæ (54) as given for “isotropic” material (i. e., material whose extension and contraction under equal Loads are equal).

[The limitation to the application of formulæ (54) to this Case is of course that p'' must be positive (i. e., represent *pressure*), so that if (on trial) p'' be *negative* the formulæ (54) are *inapplicable*, i. e., do not yield the true values of either Stress, but it must be remembered that the fact of p'' becoming *negative* would indicate *tension* over part of the cross-section, in which case the Pillar *must fail* by tearing, (it being supposed incapable of resisting tension), or at any rate be dangerously strained].

66. *Application of formulæ (54)*.—These formulæ are true for any cross-section. It is practically sufficient (Art. 61) to find the stress-intensities for the cross-section of greatest stress only, which will be *assumed* (Art. 61) at $\frac{1}{2}$ of depth of sinking below current-bed. All the quantities W, A, M_H, a, β, I_o must of course be taken for that section.

* See “Professional Papers on Indian Engineering,” Second Series, No. LXXV., on “Transverse Strain in Pillars”, by the present writer.

The quantities W , M_H are of course to be calculated by the principles and formulæ of Sections II., III., IV.

The calculation of W presents no difficulty. M_H is strictly the Resultant Bending Moment of *all* horizontal forces above the plane of greatest stress, and therefore includes a partial Moment of both up-stream and down-stream Horizontal Sub-soil Re-actions (R_H, R'_H).

It appears (to the author) that at any such small depth (as chosen) below current-bed both these partial Moments will be *very small* compared with the *large* Moment of Disturbing Forces.

The uncertainty as to their distribution makes it unadvisable to increase the complexity of the calculation by attempting to introduce them, if the error consequent on their omission is small. Now this error is not merely *small* (as explained), but is an error on the side of safety, because it is easily seen that the partial Moment of R_H' must be greater than that of R'_H and therefore that the (omitted Resultant Moment of R'_H, R'_H is a moment of *opposite sign* to that of the Disturbing Forces, so that the omission is equivalent to an *over-estimation* of the moment M_H , and is therefore an error on the side of safety. It seems therefore sufficiently accurate for the present Problem to estimate M_H as equal to the Moment of the Disturbing Forces only.

67. *Application to cylindric Wells.*—The cross-section being a circle,

$$\left. \begin{aligned} \text{Area} = A = \pi r^2 & \dots\dots\dots \\ a = r = \beta & \dots\dots\dots \\ \text{Moment of inertia}^* & \dots\dots\dots \\ \text{about centre,} \dots & \dots\dots\dots \end{aligned} \right\} I_o = \frac{\pi}{4} r^4 \dots\dots\dots \quad (55).$$

Hence formulæ (54) become,

$$\left. \begin{aligned} p' &= \frac{W}{\pi r^2} + \frac{4 M_H}{\pi r^2} \dots\dots\dots \\ p_o &= \frac{W}{\pi r^2} \dots\dots\dots \\ p'' &= \frac{W}{\pi r^2} - \frac{4 M_H}{\pi r^2} \dots\dots\dots \end{aligned} \right\} \dots\dots\dots \quad (54A).$$

[N.B.—It is convenient in the first instance to take the lineal *foot* and *avoirdupois pound* as units of length and weight throughout.

The resulting quantities p', p_o, p'' will of course be in *pounds per square foot*. These should finally be reduced to their equivalents in *pounds per square inch*].

68. *Level of no Tensile Stress.*—It appears from actual examples of *cylindric Piers* in the Oudh and Rohikhand Railway (see Ex. in Art. 69) that there is always *severe Tension* at plane of Greatest Stress; hence the following important results:—

“Masonry simply set in Mortar is *unsafe* for Well-foundations”,..... (56).

Well-foundations should be tied vertically with iron-ties about level of current-bed to enable them to bear this Tension safely,”..... (57).

Hence an important question arises, viz., to find the level of no Ten-

* Rankine's Applied Mechanics, Art. 205.

sile Stress, as the vertical Tie-rods should clearly be carried to this height. This would be found by solution of the equation (54), $p'' = 0$, whence for any Well, $\frac{M_H}{I_0} \cdot \beta = \frac{W}{A}$, or in case of a cylindric well $M_H = \frac{1}{4} W r$, from Eq. (54A).

[This Equation considered as a function of d (depth of plane required) is so complex that it could only be solved by approximation. The expression for M_H would moreover require a re-casting of the formulæ (19 to 21) for Total Current-pressure and (22 to 27) for Moment of Current-pressure, as the "limits" of the integration would in general be *different* to those used in those formulæ in the actual forms given in the Text. This can be easily done from the general expressions in the Appendix].

As in the Example chosen for illustration (Art. 69), it will be easy to show that the "level of no Tensile Stress" is actually *but little below* the Flood level, and as the Example seems a fairly typical one, it appears hardly worth while to introduce here the complex formulæ for M_H in general.

The following are important practical conclusions:—

"In slender cylindric Masonry Piers exposing a large Girder-surface to Wind, the "level of no Tensile Stress" is very high up", } (58).

"Such Piers if *simply* set in mortar are dangerously liable to failure by want of Transverse Strength, (i. e., by opening of the joint under Tension) under effect of *high wind alone*", } (60).

"Such Piers should be tied with iron tie-rods nearly throughout their length" (61).

These conclusions will appear startling and even opposed to the result of experience that Piers have almost invariably failed *by tilting over*, i. e., by want of Stability of rotation (Arts. 5 and 44).

It will be well therefore to examine carefully the ground of these conclusions. In the first place the investigation from which the fact of existence of Tensile Stress is deduced by formulæ (54) depends essentially on the *hypotheses* that

(1). "Transverse applied Force causes in *Masonry* a "uniformly-varying", Longitudinal Strain over any cross-section."

(2). "Stress in *Masonry* is proportional to Strain within the elastic limit."

These are the *hypotheses* either explicitly or implicitly made by all writers on Applied Mechanics: the author is not aware that there is any experimental evidence of the truth of these hypotheses in the *particular* case of Masonry. Herein is the weak point of the investigation. They have however the weight of authority, viz., of general adoption by writers* on Applied Mechanics.

* See Rankine's Applied Mechanics, Arts. 205, 215. Rankine's Civil Engineering, Art. 263.

On these "hypotheses" it follows *necessarily* that a solid cylindric Pier is one of the *weakest* forms as regards TRANSVERSE STRENGTH: for the utmost deviation of the Centre of Pressure on any cross-section—from its centre of figure—of *all* the External Forces (both Vertical Load and Disturbing Forces) consistent with the non-production of TENSION is only* $\frac{1}{4}$ of the diameter, which in a slender cylindric wall is of course a *small* quantity (*e. g.*, only 2 feet in the Rimrangzi 16 foot Wells).

Lastly, with regard to the observed fact, that Wells have hitherto almost invariably failed not by cross-breaking, but by want of STABILITY OF ROTATION, the argument above enforced is only to the effect that—

"There will be *some* Tension throughout the greater part of the height of a slender solid cylindric Well, increasing in intensity downwards from about flood level to a little below the current-bed."

[Mr. Bell's Report gives diagrams which clearly show this important fact in the case of nine different Piers of Railway Bridges on the Oudh and Rohilkhand Railway].

It must be inferred that the quality of Mortar and partial employment of vertical iron ties have hitherto sufficed to prevent *actual* fracture, but *it does not follow* that the state of TENSION was not *dangerous* to Masonry simply set in mortar. As before stated, English *practice*† is that the TENACITY of Masonry simply set in mortar is not to be depended on.

[That the danger of cross-breaking of slender Masonry Pillars under effect of High Wind only is by no means distant may be inferred from the fact that the Ishápur Factory chimney snapped in one of the cyclones of 1864 and 1867, and the Kidharpur Church spire snapped in both those cyclones].

Example.

69. The same example is chosen for illustration of the principles and formulæ of Section V. as in Art. 57.

The plane of Greatest Stress is *assumed* at a depth below current-bed of 5 feet or $\frac{1}{2}$ \times depth of sinking for reasons explained in Art. 61.

Tables III. and IV. contain details of the calculations of the Load (W) and Bending Moment (M_H) at plane of Greatest Stress with list of references to all formulæ required; the results being $W = 1,637,580$ lbs., $M_H = 7,747,600$ lbs.

Hence by Eq. (54A).

$$\begin{aligned} p' &= 8147 + 19272 = 27,419 \text{ lbs. per square foot, (pressure).} \\ p_0 &= 8147 = 8,147 \text{ " " (pressure).} \\ p'' &= 8147 - 19272 = -11,125 \text{ " " (tension).} \end{aligned}$$

These are equivalent to

$$\begin{aligned} \text{Greatest intensity of pressure } p' &= 195 \text{ lbs. per square inch.} \\ \text{Mean intensity of pressure } p_0 &= 60 \text{ " "} \\ \text{Greatest intensity of tension } p'' &= 77 \text{ " "} \end{aligned}$$

* Rankine's Applied Mechanics, Art. 206.

† Rankine's Applied Mechanics, Arts. 205, 215.

CASE I. Well with vertical iron ties.—This Pier is amply strong enough if so tied on up-stream side (about level of plane of greatest stress) that the effective Tensile and Crushing Resistance are approximately equal.

CASE II. Masonry simply set in Mortar.—When the Disturbing Forces simultaneously reach their maxima, the masonry will be *very dangerously strained*, as it has been shown that a large Tensile Stress will fall on the up-stream side at the plane of greatest stress—(the tenacity of the mortar being disregarded).

[*N.B.*—The Tensile Stress will not be exactly 77 lbs. per square inch, as formulæ (54 A) are not applicable to Case II. when actual Tension exists. The *proper* formulæ for calculating the Stresses in Case II. when actual Tension exists are so complex, that it does not seem worth the labor of calculation].

It having been shown that there is severe *Tension* at plane of Greatest Stress, it becomes important to find out the level of “plane of no Tensile Stress”, as below this level the Masonry should certainly be tied with iron Ties.

Now it is easily seen that at the Flood-level,

$$W = \text{Weight of Girders} + \text{Weight of Pier above flood level},$$

$$= 44,800 + 112.5 \times \pi \times \left(\frac{13}{2}\right)^2 \times 10.85, = 206,880 \text{ lbs.}$$

$$M_H = \text{Moment of Wind on Girder} + \text{Moment of Wind on Piers},$$

$$= 12,680 \times 13\frac{1}{2} + 2430 \times 5.4, = 184,300 \text{ foot-pounds.}$$

$$\text{Also by Eq. (54A), } p' = \frac{W}{\pi r^2} - \frac{4M_H}{\pi r^3} = \frac{Wr - 4M_H}{\pi r^3}$$

$$\therefore p' = \frac{206,880 \times 8 - 4 \times 184,300}{\frac{22}{7} \times 8 \times 8 \times 8} = 566 \text{ lbs. per square foot pressure.}$$

Hence the Least intensity of Stress at Flood-level is 566 lbs. per square foot, or 4 lbs. per square inch, and is *pressure*.

The actual **PRESSURE** is so small that it is obvious that **TENSION** must ensue at a *short* distance lower down; in fact on repeating the process at the level of the top of the Well, it appears that at that level there is an *actual* **TENSION** of 5 lbs. per sq. in.

It follows therefore that “from some *short* distance below Flood level there is some vertical **TENSION** at each cross-section increasing downwards to some short distance below the Current-bed”. This bears out the general “conclusions” in Art. 68.

TABLE III.—VERTICAL LOAD AT PLANE OF GREATEST STRESS.

	Weight in perc. ft.	Volume in cubic feet.	Weight in lbs.	Reference to Text.
Girders,	44,800	
13 foot Pier,	112.5	$\pi \times \left(\frac{13}{2}\right)^2 \times 27.85$	416,070	Arts. 17, 18.
16 foot Well,	112.5	$\pi \times \left(\frac{16}{2}\right)^2 \times (47 + 5)$	1,176,710	Arts. 17, 18.
∴ Vertical Load at plane of greatest Stress, i. e., W =			1,637,580	Art. 66.

$$\begin{aligned}
 &= k\pi \cdot \frac{V_0^3}{2g} \cdot \beta \cdot \int_0^D \left(1 - \frac{2d^2}{D^2} + \frac{d^4}{D^4}\right) \cdot dd, \text{ where } \beta \text{ is some value of the} \\
 &\quad \text{variable } d \text{ intermediate to } b_0 \text{ and } b_D. \\
 &= k\pi \cdot \frac{V_0^3}{2g} \cdot \beta \left[d - \frac{2}{3} \cdot \frac{d^3}{D^2} + \frac{1}{5} \frac{d^5}{D^4} \right]_0^D \\
 &= k\pi \cdot \frac{V_0^3}{2g} \cdot \beta \cdot D \cdot \left(1 - \frac{2}{3} + \frac{1}{5}\right) = \frac{8}{15} \times k\pi \cdot \frac{V_0^3}{2g} \cdot \beta D \text{ in general.}
 \end{aligned}$$

Now $\beta = b_0 = b_D$ if the Pier be cylindrical.

$$\beta = \frac{1}{2}(b_0 + b_D) \text{ approximately, if the Pier taper only slightly.}$$

Hence

$\beta D = A$ in former case, and approximately in latter case.

$$\therefore P = \frac{8}{15} \times k\pi A \cdot \frac{V_0^3}{2g} \text{ for a cylindrical Well, and approximately also for a Well}$$

with continuous slight taper. This is Eq. (19) of Text.

CASE II Short cylindrical or *slightly tapering* Pier on a *broad cylindrical or slightly tapering* Well.

[If the breadth of Pier at base be very different to that of Well at top, the cross-sections are *discontinuous*, and the previous formulæ inaccurate. The Total Pressures on Pier and Well must be separately estimated. It is considered that the *slight taper* may in practice be disregarded].

Let P' , P'' = Total Current pressures on Pier and Well.

b_0, B = Average breadths of Pier and Well.

d_1 = Depth of top of Well below surface

Then by a slight modification of steps of Case I,

$$\begin{aligned}
 P' &= \int_0^{d_1} p \cdot dd = k\pi \cdot \frac{V_0^3}{2g} \cdot b_0 \left[d - \frac{2}{3} \cdot \frac{d^3}{D^2} + \frac{1}{5} \frac{d^5}{D^4} \right]_0^{d_1} \\
 &= k\pi \cdot \frac{V_0^3}{2g} \cdot b_0 \cdot d_1 \cdot \left(1 - \frac{2}{3} \cdot \frac{d_1^3}{D^2} + \frac{1}{5} \frac{d_1^5}{D^4}\right); \text{ this is Eq. (21) of Text.}
 \end{aligned}$$

$$\begin{aligned}
 P'' &= \int_{d_1}^D p \cdot dd = k\pi \cdot \frac{V_0^3}{2g} \cdot B \left[d - \frac{2}{3} \frac{d^3}{D^2} + \frac{1}{5} \frac{d^5}{D^4} \right]_{d_1}^D \\
 &= k\pi \cdot \frac{V_0^3}{2g} \cdot B \cdot \left\{ \frac{8}{15} D - d_1 \left(1 - \frac{2}{3} \frac{d_1^3}{D^2} + \frac{1}{5} \frac{d_1^5}{D^4}\right) \right\}, \text{ Eq. (21) of Text.}
 \end{aligned}$$

Depth of Centre of Current-pressure.

72. CASE I Well *cylindrical*, or with *slight continuous taper*.

By the ordinary analytical process for finding Centre of Pressure and with notation as in Arts. 85, 86 and 71.

$$\begin{aligned}
 P \cdot d_0 &= \int_0^D p d \cdot dd, \text{ (if the cross-section of Well be uniform or change continuously)} \\
 &= \int_0^D k\pi b \cdot \frac{V_0^3}{2g} \cdot d \cdot dd \text{ by Eq. (18).} \\
 &= k\pi \int_0^D b \cdot \frac{V_0^3}{2g} \cdot \left(1 - \frac{d^2}{D^2}\right)^2 \cdot d \cdot dd \text{ by Eq. (16).} \\
 &= k\pi \cdot \frac{V_0^3}{2g} \cdot \beta \cdot \int_0^D \left(d - 2 \frac{d^3}{D^2} + \frac{d^5}{D^4}\right) \cdot dd, \text{ where } \beta \text{ is some value of } b \text{ in-} \\
 &\quad \text{termediate to } b_0, b_D.
 \end{aligned}$$

$$\begin{aligned}
 &= kw \cdot \frac{V_o^3}{2g} \cdot \beta \left[\frac{d^2}{2} - \frac{1}{2} \cdot \frac{d^4}{D^2} + \frac{1}{6} \cdot \frac{d^6}{D^4} \right]^D \\
 &= \frac{1}{6} kw \cdot \frac{V_o^3}{2g} \cdot \beta D^2. \\
 &= \frac{1}{6} kw \cdot \frac{V_o^3}{2g} \cdot AD, \text{ if the Well be cylindrical, also approximately if the Well} \\
 &\quad \text{taper only slightly.}
 \end{aligned}$$

Hence $d_o = \frac{1}{6} kw \cdot \frac{V_o^3}{2g} \cdot AD \div P = \frac{5}{16} D$, which is Eq. (22) of Text.

CASE II. Short cylindric or *slightly tapering* Pier on a *broad* cylindric or *slightly tapering* Well.

[If the breadth of Pier at base be very different to that of Well at top, the Cross-sections are *discontinuous*, and the previous formulæ inaccurate. The Centres of Pressure on Pier and Well must be found separately. It is considered that the *slight* taper may in practice be disregarded].

By obvious modifications of steps of Case I, and with notation of Arts. 35, 36, 71.

$$\begin{aligned}
 P' \cdot d_o' &= \int_0^{d_1} pd \cdot dd = kw \cdot \frac{V_o^3}{2g} \cdot b_o \left[\frac{d^2}{2} - \frac{1}{2} \cdot \frac{d^4}{D^2} + \frac{1}{6} \cdot \frac{d^6}{D^4} \right]_{d_1}^0 \\
 &= kw \cdot \frac{V_o^3}{2g} \cdot \frac{b_o}{2} \cdot \left(1 - \frac{d_1^2}{D^2} + \frac{d_1^4}{3D^4} \right) \cdot d_1^2 \\
 \therefore d_o' &= \frac{1 - \frac{d_1^2}{D^2} + \frac{1}{3} \cdot \frac{d_1^4}{D^4}}{1 - \frac{3}{8} \cdot \frac{d_1^2}{D^2} + \frac{1}{5} \cdot \frac{d_1^4}{D^4}} \cdot \frac{d_1}{2}, \text{ which is Eq. (23) of Text.}
 \end{aligned}$$

$$\begin{aligned}
 P' \cdot d_o'' &= \int_{d_1}^D pd \cdot dd = kw \cdot \frac{V_o^3}{2g} \cdot B \cdot \left[\frac{d^2}{2} - \frac{1}{2} \cdot \frac{d^4}{D^2} + \frac{1}{6} \cdot \frac{d^6}{D^4} \right]_{d_1}^D \\
 &= kw \cdot \frac{V_o^3}{2g} \cdot \frac{B}{2} \cdot \left\{ \frac{D^2}{3} - d_1^2 \left(1 - \frac{d_1^2}{D^2} + \frac{1}{3} \cdot \frac{d_1^4}{D^4} \right) \right\} \\
 \therefore d_o'' &= \frac{1}{2} \cdot \frac{\frac{1}{3} D^2 - \left(1 - \frac{d_1^2}{D^2} + \frac{1}{3} \cdot \frac{d_1^4}{D^4} \right) \cdot d_1^2}{\frac{8}{15} D - \left(1 - \frac{3}{8} \cdot \frac{d_1^2}{D^2} + \frac{1}{5} \cdot \frac{d_1^4}{D^4} \right) d_1}, \text{ which is Eq. (23) of Text.}
 \end{aligned}$$

Centre of Pressure of Horizontal Re-actions.

73. The depth of the "Centre" of fluid pressure against a vertical rectangle whose top and bottom lines are at depths D' and $(D' + h)$ below the surface is known to be* at a depth below that surface of

$$\text{depth} = \frac{2(D' + h)^2 - D'^2}{3(D' + h)^2 - D'^2}$$

\therefore Height of that Centre of Pressure above the base is

$$\lambda_o = (D' + h) - \frac{2(D' + h)^2 - D'^2}{3(D' + h)^2 - D'^2}, \text{ (which on reduction becomes)}$$

$$= \frac{h}{3} \cdot \frac{3D' + h}{2D' + h}, \text{ or } \frac{h}{3} \cdot \left(1 + \frac{D'}{2D' + h} \right); \text{ this is Eq. (32) of Text.}$$

* Cape's Mathematics, Vol. II., Art. 424.

Position of Resultant of Vertical Friction.

74. It is explained in Arts. 21 and 52 that at instant of incipient motion the Vertical Friction is confined to the down-stream side of the Pier and that its distribution round that side may be graphically represented by a *very thin* semi-circular wedge. This distance of the Resultant of a system of Forces so distributed from the centre of the wedge is known to be* in general

$$\begin{aligned} x_0 &= \frac{3\pi}{16} \cdot \frac{r^4 - r'^4}{r^2 - r'^2} \text{ where } r, r' \text{ are the external and internal radii of base,} \\ &= \frac{3\pi}{16} \cdot \frac{r^4 - (r+t)^4}{r^2 - (r+t)^2}, \text{ if } t \text{ be the thickness of shell,} \\ &= \frac{3\pi}{16} \cdot \frac{4r^3t + 6r^2t^2 + 4rt^3 + t^4}{3r^2t + 3rt^2 + t^3}, = \frac{3\pi}{16} \cdot \frac{4 + 6\frac{t}{r} + 4\frac{t^2}{r^2} + \frac{t^3}{r^3}}{3 + 3\frac{t}{r} + \frac{t^2}{r^2}} \cdot r. \\ &= \frac{3\pi}{16} \cdot \frac{4}{3} r, \text{ when } t \text{ is (as supposed) indefinitely small,} \\ &= \frac{\pi}{4} r, \text{ which is Result (42), Art. 52 of Text.} \end{aligned}$$

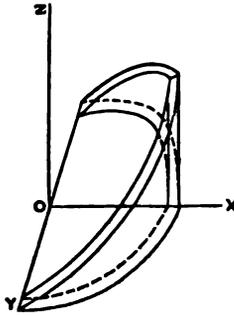

* Rankine's Applied Mechanics, Art. 83, Case XVI.

APPENDIX II.

75. Extracts of Reports on Wind-pressure referred to in Art. 23.

Extract of Letter No. 596, dated 5th December, 1872, from Meteorological Reporter, Bengal.

SIR,—I regret to say that there are very few data obtainable for ascertaining the maximum pressure of the wind. The only pressure anemometer that I know of in Bengal is that at the Surveyor General's office, and it has been blown away in both of the severe cyclones that we have had of recent years. In a cyclone on the 9th June, 1869, which was of considerable force, but which did little injury, the maximum pressure was 50 lbs. per square foot. In the North-Westers that occur chiefly in March and April, a few gusts sometimes occur of between 30 and 40 lbs. to the square foot. The readings of a cup and ball anemometer such as are generally in use at the meteorological stations, cannot be made to afford the datum you require, because in stormy winds the high pressures are always intermittent. In cyclones for example, the pressures alternate rapidly between 5 or 6 and 50 lbs. and no empirical formula by which even a rough approximation of maximum pressure under such circumstances can be obtained from total movements has been ascertained.

Extract of letter No. 236, dated 13th December, 1872, from Supdt. Science Department in Oudh.

SIR,—In acknowledging the receipt of your letter dated 9th December, 1872, I have the honor to give herewith the dates on which storms occurred with high pressure of wind registered by Osler's Anemometer—

20th April, 1868,	..	40 lbs. pressure per square foot.
11th May, 1868,	..	30 " "
19th July, 1869,	..	20 " "
23rd March, 1870,	..	25 " "
2nd May, 1871,	..	40 " "
22nd May, 1871,	..	40 " "
12th May, 1872,	..	25 " "

2. On the 23rd February, 1868, before Osler's Anemometer had been put up, there was a storm which blew down 5 walls, 7 minarets and 223 trees within the limits of the City of Lucknow. There was no means of recording the pressure of the wind on this occasion.

3. The following are the velocities on record corresponding to some of the storms previously given—

19th July, 1869,	..	8 miles in 15 minutes.
2nd May, 1871,	..	91 " 40 "
12th May, 1872,	..	76 " 35 "

A. C.

No. LXXXIV.

KALSI SUSPENSION BRIDGE FOUNDATIONS.

BY LIEUT. J. T. WRIGHT, R.E., *Assist. Engineer, D. P. W.*

6th May, 1873.

THE foundations of a new tower for the Kalsi Suspension Bridge, of which the dimensions were to be 40 feet \times 15 feet, had to be carried down to a depth of 20 feet below low-water level. The excavation, which was commenced on the 5th February, was to be completed by the end of March at latest.

Owing to the want of space, due to the proximity of the back pier on one side, and the nearness of the river on the other, it was not possible to dig an open pit, for the soil, which consists of boulders, loose gravel and

Fig. 1.

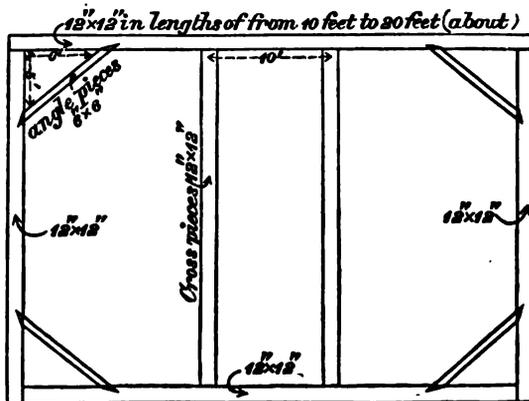

sand, would not have stood at a less slope than 2 to 1. The following

plan was devised by the Superintending Engineer:* Wooden cases of 12 inches \times 12 inches scantling of cheer wood were to be fixed, commencing from low-water level in the same way as the cases of an ordinary mining shaft, i. e., the first case having been fixed, the earth underneath it was to be excavated to allow of the fixing of the second case, in lengths not exceeding 20 feet, and so on.

The interior dimensions of the first case were 42 feet \times 29 feet, so as to allow of the cases being fixed with off-sets of 4 inches in their length to admit of the arrangement described below.

As soon as the water level was reached the water began to make very quickly, and it was at first feared that the single pump (7-inch Gwynne's centrifugal) would be insufficient to keep the water down.

Fig. 2.

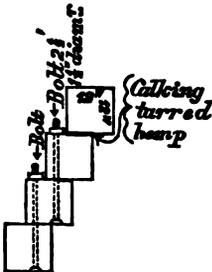

It would not have been possible to drive piles in such soil and make a regular coffer-dam to keep out the water: so the joints between the cases were to be made water-tight in the manner shown in Fig. 2. The bolts were to come up through slots in the off-sets, and tarred hemp was to be laid between the cases, the nuts being screwed well down to make the joint water-tight.

It was, however, found that practically the water never came through between the cases, but that as each successive case was fixed, the water ran down behind it and came up underneath.

Fig. 3.

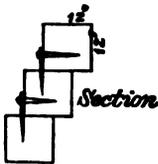

The arrangement of bolts and tarred hemp was therefore rendered unnecessary, and each case when placed in position was connected with the one above it by flat iron spikes 10 feet apart (with eyelet holes in the upper ends) driven into the off-set, and spikes driven horizontally through the eyelet holes into the case

above (vide Fig. 3).

Owing to the looseness of the soil much difficulty was experienced in getting the timbers of the cases into their proper position; for a single small stone or a little gravel falling down into the place prepared for a timber, when the timber was being placed in position, necessitated its removal and fresh clearing. At first the timbers were driven into their

* Major E. Perkins, R.E.

places by blows of heavy wooden mallets; but the shock of the blows to the soil caused the above mentioned hindrance: so the following plan was adopted. Pieces of angle-iron were placed horizontally on chocks of wood, and when greased the timber was placed on the iron (*Fig. 4*), and but

Fig. 4.

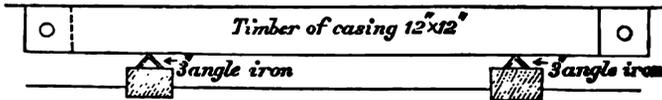

slight pressure was needed to run it gently into its place.

Occasionally large boulders of several cubic feet content would be found in the line of the casing and cause considerable delay: it was found better to leave such boulders in their places and to cut away sufficient of them with chisels to allow of the timber being fixed.

When a depth of 10 feet below low water level had been reached, the boulders came to an end, and a stratum of hard gravel was reached. At this period of the work the pump got choked, owing to the chips from the carpentering in the foundations getting through the strainer, and the foundation filled with water. When it had again been emptied, it was found that three of the lower cases had, (owing to the cross pieces not having been fixed,) by their buoyancy got wrenched out of position. The getting of them into proper position again was found to be so tedious, that it was resolved, as there was ample room (the dimensions of the pit at 10 feet deep being 41 feet \times 20 feet) to set off at that depth a fresh set of casings entirely within the others, the internal dimensions of which were to be 40 feet \times 18 feet. This was done, and by the 20th March seven more cases had been fixed, making a total depth of 17 feet below low-water level, and 14 feet 6 inches below the lowest level of the bed of the river. As time pressed, and a firm subsoil had been reached, orders were given to go on with the masonry at once. The masonry has up to the present date been carried up to a height of 22 feet, and the whole of the wood used in the casing has been extricated; each case was taken out piece by piece as each foot of masonry, was completed; the place vacated by the timber being immediately filled in with large boulders.

The earth from the excavation was raised on to stagings in boxes with movable bottoms, containing 4 cubic feet each, by means of crab winches.

The large boulders met with were raised by an Eade's block (3 tons). Work was carried on night and day.

Remark.—There would not seem to be any practical difficulty, where engine power for pumping is available, in carrying down a foundation in this way to any depth, provided the casing be of strengths sufficient; and the expense need not be unreasonable. The Gwynne's centrifugal pump worked admirably day and night from 10th February to the 5th May, keeping the foundation almost entirely dry, and got out of order but twice; once when it was choked with chips of wood, and once when the leather of the valve in the valve box got destroyed by the sharp gravel which got through the strainer. The nozzle of the pump was always sunk $2\frac{1}{2}$ feet below the bottom of the excavator, and an open space was kept clear round the strainer by men working with their hands. The delay of adding a fresh length of pipe is considerable, so it is advisable in a work of this sort to have two pumps, so that the pumping need not be stopped while a joint is being made. It is a good plan, when there is but one pump, to support the pump platform by wedges, screw jacks, &c., so that it can be lowered (without stopping the pumping for long), a foot or so at a time as the excavation proceeds. The pumping engines were—1st, a 10-horse-power portable Clayton and Shuttleworth; 2nd, a 12-horse-power do. The belting was worked from the large fly-wheel, as the revolutions being slower the bearings did not get so hot.

J. T. W.

No. LXXXV.

BULL'S PATENT "OBLONG" FLAME-KILN.

On a principle Patented by W. BULL, Esq., C.E., Resident Engineer, O. & R. Railway, Lucknow.

In the 5th Quarterly number of the "Professional Papers on Indian Engineering," 2nd Series [No. XLIX.], published in July last, a description was given of a new form of Kiln, combining increased efficiency, with great economy of fuel. Drawings of an "Annular Kiln" for continuous firing accompanied the description, but it was pointed out that the system applied equally well to kilns of an oblong form. The circular form of kiln requires a large area for erection and working. The oblong form, of which a plan is here given, will be found more suitable for places where a large area is not obtainable; the principle of working being the same in both.

The arrangement for turning the corners is shown in the plan. In the square portion of kiln at each corner, for firing which flues are only available on one side, they (the flues) are closed in as high up as possible, and serve for the passage of the draught into the passages running at right angles to those in the part referred to.

In practice it has been found that the open brick on the top of the draught passages described in the former Article is not required. The parallel walls of unburnt bricks are therefore only closed in at top by a single brick flat, on which the thick layer of ashes or earth should be spread.

A kiln of the description here given is capable of burning 20 lakhs of bricks in one season.

Further, practice has proved that the economy, simplicity and certainty, realized by burning bricks on this plan are so great, that but for the apathy with which anything new is treated in India, the ordinary style of Flame Kiln would soon become a thing of the past.

W. B.

**BULL'S PATENT FLAME KILN
FOR CONTINUOUS FIRING.**

Scale, of $\frac{1}{16}$ inch = 1 foot.

Elevation

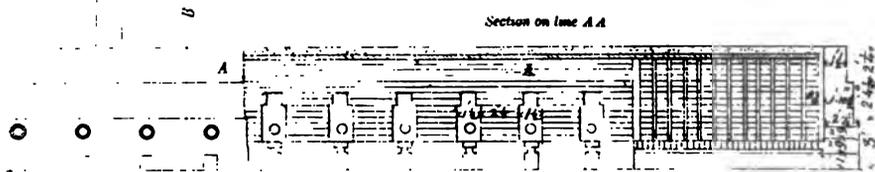

Section on line A A

Plan and Sections of one end of a Kiln.

Plan of Top

Sectional Plan of Top with covering brick removed

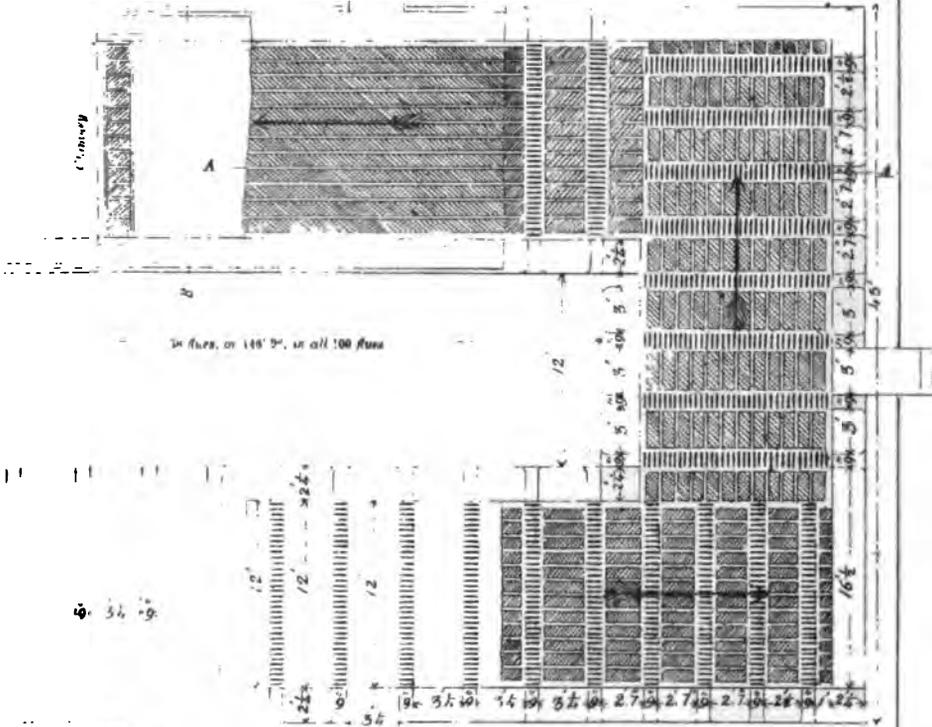

14 flues, or 146 sq. ft. in all 100 flues

Ground Plan

Sectional Plan at same level before setting the Flues

Section Plan at Level of Firing Flues, showing the method of setting the Brick for the Flues and Draught Passages

springe for loaming the Brick be left at pleasure over the top of firing Flue

Line arrows show the direction of the firing

Sheet upon Chimney



Cross Section on line B. B

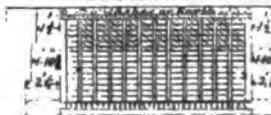

Earthen Drummy in clear-mouth of flue





No. LXXXVI.

IVE'S PATENT EXCAVATOR.

By R. T. IVES, *Engineer, Department Public Works.*

In this Article, I propose to introduce to the notice of the Civil Engineering Profession in India, drawings of an Excavator, which I hope may prove a successful addition to the many inventions now extant for the furtherance of railway bridges and other works in this country. The invention is my own, and I have the greatest satisfaction in stating, that the machine is now in full and successful working in the reconstruction of the Beas Bridge Works, on the Sind, Punjab and Delhi Railway, and meets with, I believe, the thorough approbation of the Engineers in charge. Thus it will be seen, it is peculiarly adapted to all works of the class of heavy well sinking for railway bridge purposes—and it can be applied to any, and all kinds, of excavations, such as “deep foundation under water,” &c., &c. On this head I venture to hope the drawings will be sufficiently explicit.

I may mention that from past experience in well sinking, and heavy works on the “Soane” and “Jumna” Bridges of the East India Railway, and also on the works of the Chenab and Ravee Bridges of the P. N. State Railway, the fact was forcibly impressed upon my mind that the several inventions in vogue were somewhat insufficient in the working out of any substance, except sand, from the many wells under construction I may be permitted to mention further (although I do not desire to detract from their value) the invention I have now the pleasure to note will contrast most favorably with the working of those of Messrs. Fouracres and Bull, inasmuch as their Excavators do not effect the removal of such heavy materials as clay, kunkur, &c., from deep wells and foundations. It was after careful study and experiments that I determined upon the present

plan and matured details of the invention. It successfully and permanently removes, without difficulty, all such heavy materials as are mentioned above, and prevents the necessity of employing European divers on such difficult work as is experienced in deep well sinking, sixty to seventy feet under water. It is this that has induced me to contrive an Excavator to do this work independently of divers.

You will perceive by the sketch, that this Excavator differs very much from all others in entering the soil to be removed, by avoiding all circular motions in trying to penetrate the clay. The blade of the Instrument represents as nearly as possible the blade of a shovel or spade on a large scale, and goes straight into its work, not by the pressure of a man's foot or shoulders [as that force is not possible at the bottom of a well seventy feet deep, where it is only possible to a diver,—whose work this instrument replaces to a certain degree—] but by the repeated blows a heavy weight, called a cast-iron monkey, worked by a line in any position above water. It has been the great desire of the Inventor to turn out as simple an instrument as possible;

1st.—To avoid in the Excavator all springs, cams, clutches, pullies and all such like complicated gear, so liable to derangement in the hands of unskilled labor.

2nd.—That the commonest field laborer should be able to work and understand its action, and the principles of the work which is put into his hands to perform, without the risk of any damage, due to the rough usage that Natives generally give to tools which do not belong to them.

3rd.—That it should be manufactured and sold for a small sum, so that any kind of works, however limited the works may be, could afford the purchase of one or more of them, even to sink wells for common District Road Bridges, and effect a saving in the generally low estimates for such work.

MODE OF WORKING THE EXCAVATOR.

The Excavator lock at the back is first pushed into place, a light line is then attached to the lock; the blade being now open or vertical with the monkey guide rod, the Excavator is lowered to the bottom of the well, where the whole instrument is kept in an upright position by the lowering chain being kept slightly tight. The monkey is now worked up and down the centre guide rod, by the line attached to it leading over a pulley fixed

P WELL FOUNDAT

R. R. J. IVES, P. M. ST. RY., P. W. D.

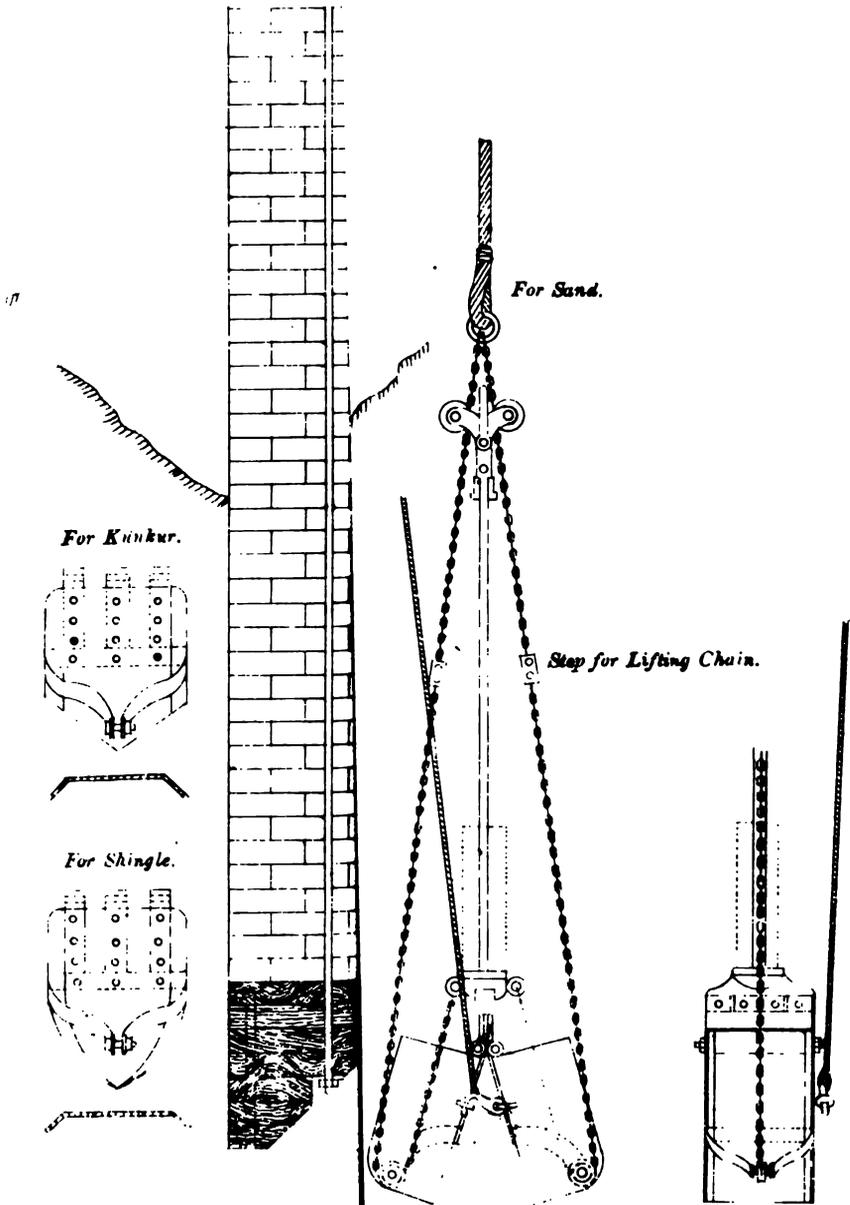

1/4" to 1 inch.



over the well: the monkey being allowed to fall of its own gravity, giving a sharp blow to the anvil, and driving the blade into the clay at each blow: the number of blows required to drive the Excavator home should be ascertained by a trial above ground. After this number of blows have been given, (with a few extra, to allow for the resistance of the water,) the locking gear line is then pulled which draws out the locking bolt and releases the blade from its vertical position; when this has been done, the lifting chain is hove on by the crab, which drags the blade out of the clay with its load, in a position at right angles with the monkey guide rod. The blade now remains stationary in this position, and the continual heaving on the lifting chain brings the whole to the top of the well, when the shackle at the top of the Excavator catches a hook properly suspended from the gallows to receive it, swings the Excavator over a shoot, and lets it there empty itself, by the blade again falling to a vertical position, and all strain being taken off the lifting chain. The blade is now again in a position to receive the bolt of the locking gear, which is pushed into place by one of the men on the well. This completes the whole operation of working this Excavator, which must be very simple to all.

The Excavator consists of several pieces of the most simple construction, allowing of any single part, on becoming damaged, being easily removed and replaced by the several spare pieces supplied with the machine, and always kept on hand; such pieces can always be made while the machine is at work, in anticipation of a break down at any time, needing only the stoppage of a short time to change any broken part. Many cast-iron monkeys can be kept on hand of various weights, and changed to suit the hardness or softness of the soils to be excavated.

The Excavators are made of various sizes: the smallest size now in use on the Beas Bridge of the S. P. and D. Railway requires about five men and a mate to work it; with a single crab-winch on the top of the well, it will lift by this number of men, from one and a half to two cubic feet of hard clay at every lift, or from seventy-five to eighty cubic feet per day of twelve working hours: on some works I have seen not more than from nine to sixteen cubic feet taken out in twelve hours, with fifteen to twenty men, so difficult was it to get hold of the clay at the bottom of the well with the tools supplied for the work.

The small Excavator is about eight feet in length over all, and weighs

from three to four maunds. As well as various sized monkeys, there are also many blades of various shapes and forms supplied with the machine for the purpose of fixing to it to suit all sorts of clay, kunkur, shingle, sand, or any other kind of substances.

R. T. I.



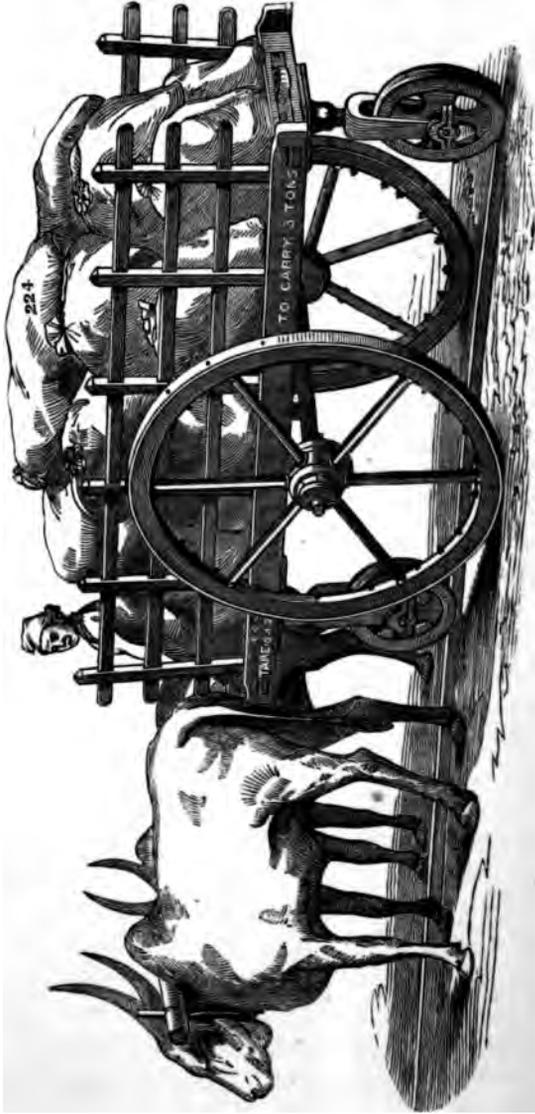

ADDIS' SINGLE-RAIL TRAMWAY.

No. LXXXVII.

ADDIS' SINGLE-RAIL TRAMWAY.

THE Frontispiece represents one of Addis' Patent Carts on his Single rail Tramway, as in use at Bombay and elsewhere. A tramway on this system can be laid, on which one pair of bullocks can draw a load equal to, or exceeding, that which three pairs can draw upon an ordinary metalled road; while the cost of the tramway need not exceed that of the ordinary road.

Mr. Addis patented his "Cart and Wheel" in 1868; and in 1869 they were tried and favorably reported upon by the Bombay Commissariat Department. In the report on the Akola Exhibition they were thus described:—

"Certainly one of the most useful models in this room was 'Addis' Patent Cart and Wheel.' It comprises two essential points, first the wheels are formed of segmentary parts of wrought-iron, circumferenced by felloes, and tired in the usual manner; the nave is flush with the spokes, thus lessening the risk of collision. Among the advantages possessed by this invention, the wheel is calculated to be durable, and easier of construction. The two axles, six inches in length, work in journals, and are easily arranged in case of damage. Another palpable advantage is that the pole is so arranged as to admit of the cart being drawn back without the necessity of turning, while it can be wholly withdrawn, passed through the centre of the box, in the body of the cart which contains a tent, and used as a tent-pole, while the platform can be used for sleeping on in swampy localities. The exigencies of the Abyssinian Expedition prompted this invention."

Mr. Addis has made several varieties of carts for military, sporting, and other purposes, some being filled with bell-shaped tents: also as road

watering carts, night soil carts ; the prices at Tanna, near Bombay, ranging from Rs. 150 to Rs. 350.

The system of "One-rail Railway," is now coming into use in Europe. A railway on Larmenjat's system, has been introduced into Lisbon, when it runs on a single rail along the common thoroughfares. In the (London) *Public Opinion*, of 24th August, 1872, the following notice of this principle occurs:—

"The importance of an extremely cheap system of railway, capable of providing outlying districts with better means of reaching the existing lines, and of facilitating transit in towns, has long been recognised by Engineers, and it appears that such a system has now been devised. M. Larmenjat has, reports the *Mining Journal*, just laid down at the Place du Roi de Rome, at the Trocadéro, Paris; his one-rail railway, and *La Houille* announces that the official experiments on Thursday were highly satisfactory. The invention appears to be identical with those of Mr. Addis, an English Engineer practising in India, which was described a few years since. The Locomotive weighs four tons, and has two wheels running bicycle-fashion on the rail, two other wheels in the usual position, and with caoutchouc tyres running on the roadway. The Engineer can throw the weight on the rail-wheels or road-wheels, at pleasure, the latter increasing the bite, and facilitating the ascent of an incline ; there is 1 in 33 on the trial line. The rail weighs about 7 kilos. to the metre (15 lbs. to the yard), and does not rise above the roadway. A speed of 8 to 11 miles an hour is attained, the motion is smooth and pleasant, and no difficulty is experienced in turning very sharp curves, the two loops at the ends of the line (which is about a quarter of a mile long) for permitting the train, consisting of the engine and 3 carriages, to change its position ready for the return journey affording a very severe test."

The following is the Patentee's specification:—

This invention has for its object the laying down of a Single Rail on any existing Road or any Road made specially for the purpose of a Tramway.

I first form a single rail for my line, making use of any existing rail either of steel or iron, and of any size or description. This rail to be ballasted up to the level of the road.

It is purposed to run upon this line vehicles of every kind and description, constructed after the ordinary ones now in use, with an additional

wheel or wheels, varying with the length of the vehicles. This same wheel or wheels to be attached to the bottom of the platform of framework of the vehicles, and to be flanged on both sides in order to prevent any moving off the rail.

The vehicles themselves will have two or more wheels, which will run on the road on either side of the rails, while the centre double flanged wheel or wheels run on the rail. These wheels work on a swivel attached to a screw, in order to raise or lower the body or framework of the vehicles above the surface of the ordinary road on either side, so that the whole of the weight of the vehicles and their contents would rest on the rail, and their balance would be supported on either side by their own ordinary wheels.

The centre double flanged wheel or wheels will have further attached to them springs on either side in order to prevent jarring and jolting, and to give them a fair amount of play to suit the irregularities of the road, which would naturally tell upon the ordinary wheels of the vehicles.

The vehicles can be worked over the proposed tramway either by steam or cattle power.

A model of the above invention can be seen at the Bombay Chamber of Commerce.

The Patentee claims for his invention the following advantages :—

1st.—It can be laid down on one or both sides of any existing road at a distance of from three to four feet from the edge of the road.

2nd.—Where no road exists, it can be laid down very well, and quite good enough for ordinary traffic, by ballasting a strip eighteen inches wide.

3rd.—It can be laid down very rapidly : forty men can lay a mile of it down per day with the greatest ease.

4th.—It is very cheap : the cost on an existing road, including rails, sleepers, nails, being not more than Rs. 6,220* per mile, as per estimate attached. The cost on a road to be made on purpose would be very little more, the extra expenditure being necessary on account of the little ballasting noticed above.

5th.—The cost of a truck is Rs. 325, exclusive of carriage to site of tramway.

6th.—Upon the tramway a single pair of bullocks can draw from four to six times as much as in a common cart on an ordinary road.

* For a "Wooden Sleeper" line, Rs. 4,350.

7th.—It does not interfere more than to the very slightest extent the ordinary traffic.

8th.—Should it get out of repair, the most ordinary village can put it to rights: should the trucks also get out of order, the thing is true.

9th.—It can accommodate itself to the sharpest curves ever met in ordinary roads, and even in those which would be met with in the streets of a town.

Sketches and estimates of a tramway laid with either iron or steel sleepers are appended.

Section of Single-headed rail. Scale one-fourth.

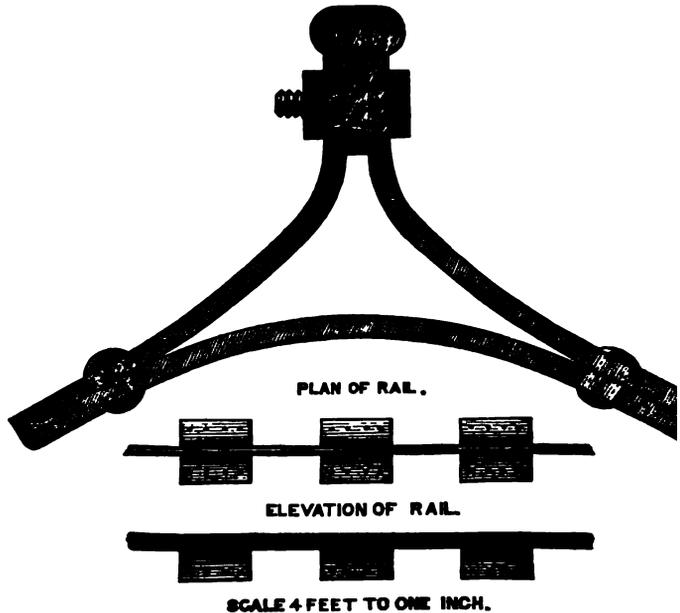

ESTIMATE FOR LAYING ONE MILE.

	Weight in Tons.	Amount RS
1 Lower Plate,	14-9163	} 4,200
2 Lateral do.,	21-8772	
Rail, @ 20 per yard,	15-7148	} 15
Bolts and Nuts,	7857	
Rivets,	5238	} 10
	53-8178	
Carried forward, ...		4,410

									RS.
								Brought forward,	4,430
								Freight and Insurance in Bombay,	1,300
									<hr/>
									Rupees,
								Laying down per mile,	100
								Royalty @ 3 annas per yard,	330
								Sundries,	60
									<hr/>
								Total Rupees,	6,220*
									<hr/>

The above is calculated to be constructed on any existing road. The cost of maintenance on this system will be one-third that of a Wooden Sleeper Line.

Section of Foot-rail with Wooden Sleeper. Scale, one-fourth.

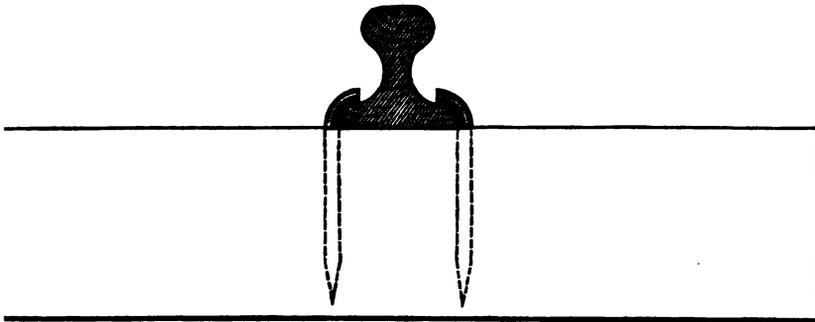

ESTIMATE FOR LAYING ONE MILE.

									RS.	A.	P.
								24 Tons Rails,	2,880	0	0
								700 lbs. Spikes,	87	8	0
								1,760 Sleepers,	440	0	0
								Laying,	385	0	0
								Ballast,	200	0	0
								Royalty, @ 2 annas per yard,	220	0	0
								Sundries,	87	8	0
									<hr/>		
								Total Rupees,	4,250	0	0*

W. J. A.

* To this amount must be added the carriage of materials from Bombay to site of tramway.

No. LXXXVIII.

PORTLAND CEMENT AT KURRACHEE.

By W. H. PRICE, Esq., *M. Inst. C.E., Superintendent, Kurrachee Harbour Works.*

Manora, 5th July, 1873.

THE following table gives the weight, bulk, and density of Portland Cement from three different manufacturers as despatched from England, and as found in India at Kurrachee, after periods varying from nine to eighteen months.

Six casks of each consignment experimented on were carefully weighed, and their gross weight noted, the average was ascertained (the weights varied very slightly), and the cask which came nearest to this, was selected for trial. The cask was then opened, and the cement carefully weighed, and measured, the contents being shovelled as lightly as possible into the measure, and "striked." The weights as despatched from England were ascertained from the invoices, and the densities from Mr. Parkes, the Consulting Engineer, who tested the cement before shipment.

It will be observed that the weight had increased in the interval in proportions varying from $\frac{1}{2}$ to $4\frac{1}{2}$ per cent., and the bulk from 4 to $12\frac{1}{2}$ per cent., while the density (deduced from the two former), had decreased in proportions varying from $1\frac{1}{4}$ to $9\frac{3}{4}$ per cent. The greatest increase of weight was in the lightest cement (White Brothers), and the greatest increase in bulk was in the heaviest (Knight, Bevan and Sturge), which also shows the greatest decrease in density.

It is believed that the changes in question were caused by moisture taken up from the air on the voyage, and in keeping in India.

This supposition is confirmed by the fact, that in making sample specimens into mortar for trial here, the proportion of water found requisite was less than had been used by Mr. Parkes, the Consulting Engineer, in making up similar specimens with the fresh cement in London, the bulk of water and cement having been in both cases carefully measured.

The heavier cement as containing more lime was naturally the more liable to swell under the influence of moisture.

The "air slaking" thus undergone, does not appear to have been injurious, but rather on the contrary to have been beneficial, especially in the case of the heavier cements. This has been shown by the behaviour of the cements in extensive use. Thus the concrete blocks for the Manora Breakwater, each 27 tons in weight, and containing $33\frac{1}{2}$ cwt. (English weight) of cement, (the other materials being sand, shingle, quarry lumps, and salt water,) were frequently lifted, conveyed on trucks, and set in the work in a month from the time of making.

On one occasion a block was set in ten days from the time of making. The cements were all found to stand the voyage and keeping in India very well, though without any special precaution, having been packed in the ordinary fir casks (which when emptied were used as fuel), and the storage sheds being merely adopted to keep off rain and dew. Thus out of a number of 18,809 casks used up to the present time, only 40 casks or $\frac{1}{4}$ th per cent. were found unfit for use, the damage having been caused by leakage on board ship.

The cost of the cement per ton, landed and stored at Kurrachee was from Rs. 38-3-0 to Rs. 44-15-0 per ton. The variation was chiefly in the freight, the three kinds of cement costing much the same in England, or from 42s. 6d. to 45s. per ton, including cost of casks, the lowest being the Wouldham Company, and the highest White Brothers. This was before the rise in price, which took place last year, owing to enhanced cost of fuel.

PORTLAND CEMENT.

Weight, bulk, and density, as despatched from England, and as found in India at Kurrachee, after periods of from nine to eighteen months.

Name of Manufacturer, and date of despatch from England and trial in India.	Nett weight of cement in one cask.	Bulk of cement in one cask, shovelled lightly into measure and "striked."		Weight per bushel of 1·28 cubic feet.	Remarks.
		Bs.	c. ft. dec.		
KNIGHT, BEVAN AND STURGE.					
Despatched 4th June, 1870,	396	4·22		120	
Tried 7th September, 1871,	399½	4·58		111½	
<i>Increase per cent.,</i>	½	8½		..	
<i>Decrease do.,</i>		7	
Despatched 27th June, 1870,	396	4·22		120	
Tried 8th September, 1871,	402	4·75		108½	
<i>Increase per cent.,</i>	1½	12½		..	
<i>Decrease do.,</i>		9½	
Despatched 15th December, 1870,	396	4·29		118	
Tried 8th September, 1871,	398	4·75		107½	
<i>Increase per cent.,</i>	½	10½		..	
<i>Decrease do.,</i>		9	
WOULDHAM COMPANY.					
Despatched 21st April, 1870,	448	4·98		115	
Tried 7th September, 1871,	459	5·50		106½	
<i>Increase per cent.,</i>	2½	10½		..	
<i>Decrease do.,</i>		7½	
Despatched 4th August, 1870,	446½	5·29		108	
Tried 7th September, 1871,	459	5·50		106½	
<i>Increase per cent.,</i>	2¾	4		..	
<i>Decrease do.,</i>		1½	
WHITE BROTHERS.					
Despatched 21st February, 1870,	369½	4·54		104	
Tried 7th September, 1871,	386	5·00		98½	
<i>Increase per cent.,</i>	4½	10½		..	
<i>Decrease do.,</i>		5	

W. H. P.

No. LXXXIX.

THE BREEKS' MEMORIAL SCHOOL AT OOTACAMUND,
NILAGIBRIES, MADRAS PRESIDENCY.

[*Vide* Plates XLVII. to XLIX.]

Designed by CAPT. J. L. L. MORANT, R.E., A.I.C.E. and F.R.G.S.

J. W. BREEKS, Esquire, of the Madras Civil Service, who was Private Secretary to the late Sir William Denison, R.E., (Governor of Madras,) and one of whose daughters he married, was appointed Commissioner of the Nilagirri Hills in August 1868. He suddenly died in June 1872, after an able administration of nearly four years. His loftiness of character, benevolence of disposition, and consideration for others, endeared him to all classes. It was, therefore, resolved to raise by subscription a suitable memorial to his name. This took the form of a School, the design for which is herewith submitted to the readers of "Indian Engineering."

The building is in progress and one-half finished. Its chief stone was laid with considerable ceremony, by the Hon'ble J. D. Sim, C.S.L., on the 16th of May, 1873. The structure will be completed in 1873. Its details are of late English Gothic. It consists of a school-room, 50 feet by 16 feet (with an oriel window 4 feet deep); of two class-rooms 10 feet by 10 feet, of a closed porch for hats and coats 6 feet by 6 feet, of a belfry with a circular staircase, and of an underground chamber for firewood, &c. The walls are of pressed machine bricks and mortar. Granite is used for the sills of the windows, for the labels and socles of the square headed doors and windows, and for the corbel tables, of the tower, of the turret, and of the oriel window. The exterior is to be neatly tuck-pointed, and the interior to be plastered with polished shell lime.

All the angles of the building and the jambs of the windows are splayed. The floors are to be of teak wood, and are ventilated under the main and dwarf walls with perforated bricks. A layer of coal tar and asphalt (one of former to six of latter,) mixed with a little clean sharp sand has been placed over the top brick course of the basement to prevent damp rising up the walls. The roof of the main building is of corrugated iron laid over teak wood frames, the whole being well bolted together and into the brickwork. Ventilation in the ridge and through louvred dormers is provided. The whole is capped by ornamental wrought-iron ridge cresting, and with wrought-iron terminals procured from England. The roofs of the bell tower, and of the staircase turrets are valley-backed, and of stamped ornamental zinc work, procured from Holden and Co. of London. The whole of the roofs are to be coated internally with Leroy's composition, and then to be body colored and picked out with stencilling. The circular staircase is of iron. The doors and windows are of teak. The lowest sashes of all the windows are to be glazed with corrugated glass, to prevent the attention of the scholars being disturbed. All the exterior woodwork will be coated with Carson's paint, and all the interior will be payed over with linseed oil. The chimney stacks are to be of terra cotta. The side walls are to be externally ornamented with 10 terra cotta medallions (1½ feet outside diameter), with the Breeks' coat of arms and monogram (J. W. B.) in bold relief, alternately. On the exterior of each of the two chimney breasts, are to be inserted a large terra cotta medallion, (2½ feet outside diameter,) with Mr. Breeks' profile raised in bold relief. All the terra cotta has been procured from Doulton & Co. of Lambeth.

A memorial plate is to be inserted over the door leading into the school-room within the porch.

The building will cost Rs. 9,437.

A bill of quantities is appended.

ABSTRACT ESTIMATE FOR CONSTRUCTING BREEKS' MEMORIAL SCHOOL,
OOTACAMUND.

								<i>School-room.</i>
Excavating foundation,	c. yds 60
Brick in mortar,	c. ft. 3,623

ME

00

END ELEVATION



G

9d

TRANSVERSE SECTION





BREEKS' MEMORIAL SCHOOL.

DETAILS OF DOORS AND WINDOW.

SCALE.



Elevation of Porch Door.
Pierced but not Glazed

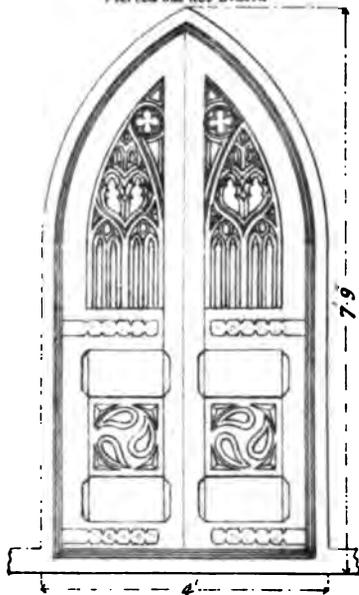

Section



Elevation of Interior doors.

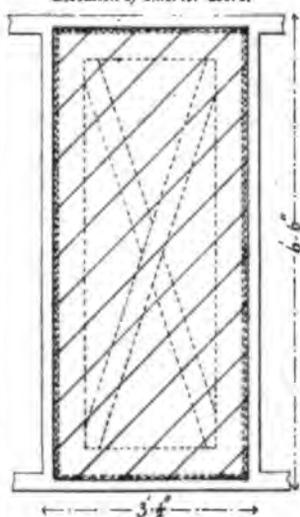

Section



Elevation of Entrance door.
(Half Panelled and Half Glazed)

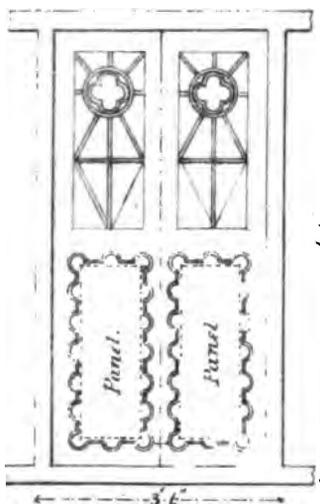

Section



Elevation of Window

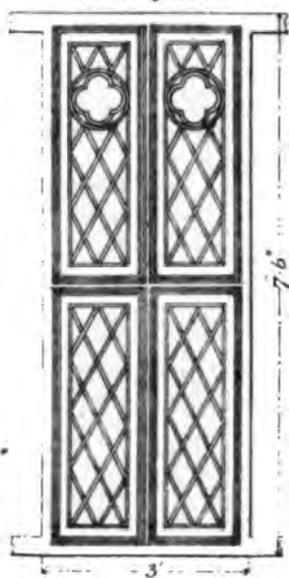

Section



Section



Enlarged Section of Mallet



Section



Inches. 8 7 6 5 4 3 2 1 0

;

Plastering, interior,	r. f.
Pointing, exterior,	236
Teak flooring,	150
Brick flooring, 1 foot square,	16
Windows,	16
Roofing with teak trusses, rafters, purlins, ties, &c., and stamped orna- mental zinc work, complete,	9½
	130
	r. f.
Cornice work,	42
Ornamental iron finial,	8
Circular iron staircase, 9 feet high,	1

J. L. L. M.

OOTACAMUND, }
26th May, 1873. }

ES & CILL.

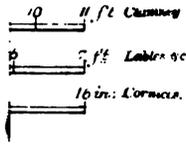

Section of
Cornice.

Front and Side



Socle

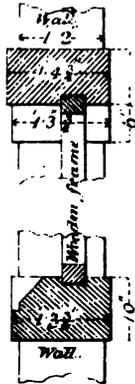

Section & Elevation of Window
Lintel, Socle and Cill.

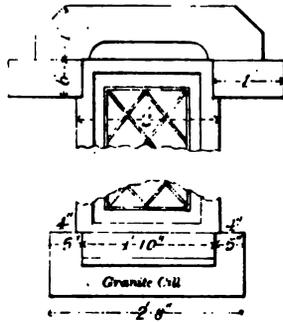

Elevation

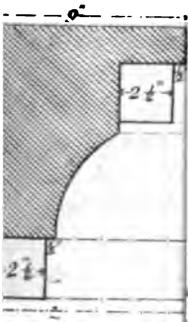

Elevation and Section of Interior Cornice.

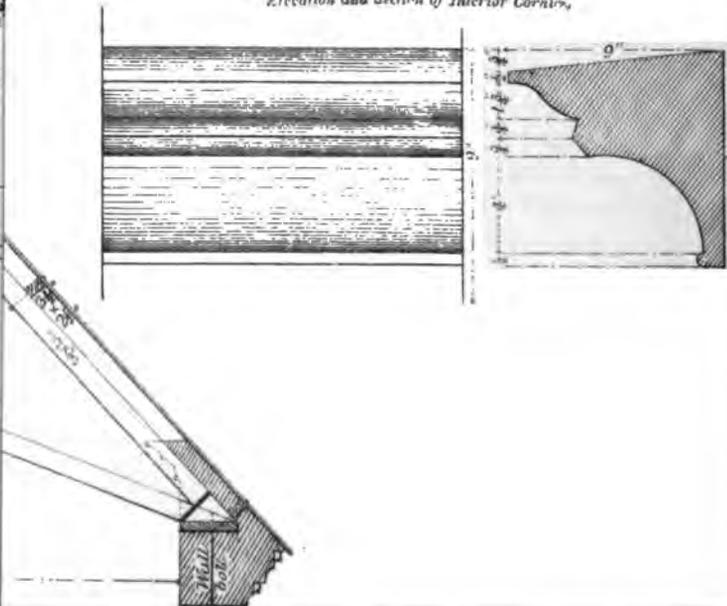

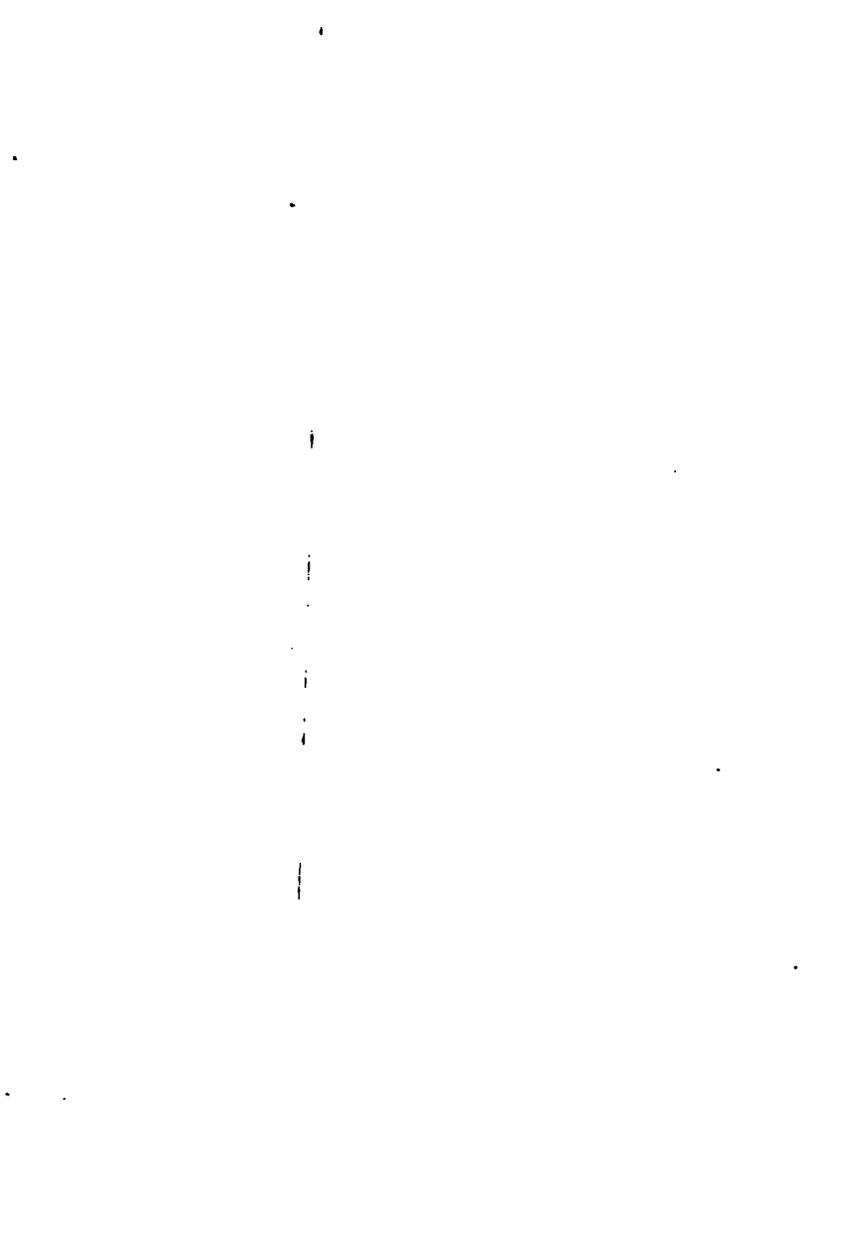

No. XC.

THE TANSA PROJECT* FOR "THE WATER-SUPPLY
OF BOMBAY."

[*Vide* Plates L. to LIV.]

BY MAJOR HECTOR TULLOCH, R.E.

THE position and extent of the Tansa Valley will be best gathered from the map, (*vide* Index Map in No. LXXVIII., Professional Papers, Second Series).† Its basin is considerably larger than that of any other valley in which a reservoir could be formed. The Vehar Valley contains little more than six square miles—the Kamun not more than twenty; even Shewla contains but twenty-five; while the Tansa watershed has an area of forty-five square miles. Its position for a gigantic scheme is most advantageous. In addition to the water falling on its own gathering ground, a supply could be obtained from the two great rivers, the Vathurna and the Bhatsa, between which the Tansa Valley lies. These two rivers, moreover, are flowing for several months after the monsoon ceases, so that, practically, there is no limit to the quantity of water to be obtained.

Besides its extensive area, the Tansa Valley, situated as it is, close to the Western Ghâts, has a rainfall considerably greater than that of the Vehar, on which our calculations have hitherto been based. In 1871 (when the monsoon failed), while 89 inches only fell at Vehar, 70 inches

* I have placed this before the Kamun Project, in order not to separate it from the other high level schemes.

† It would have been absurd to make a special survey of so large a tract of land.

fell at Atgaum, the railway station, 4 miles from the lake, and 75 inches fell at Khurdee, the railway station at the head of the valley. If we remember, moreover, that on the Ghâts, only a dozen miles to the west of Khurdee, the fall is 300 inches per annum (*i. e.*, two hundred per cent. in excess of the rainfall at Vehar) and occasionally even more than this, we shall not be making any extraordinary assumption if we take the rainfall in the Tansa Valley to be 33 per cent. only in excess of that at Vehar, or say 136 inches.* The quantity of water flowing off the Vehar gathering ground has been assumed to be 54 inches out of the total rainfall of 102 inches. At the same rate, the quantity of water flowing off the Tansa ground would be exactly six feet. If, then, the average area of the waterspread be taken as 6 square miles, the total quantity of water obtainable from the Tansa Valley will be as follows:—

	..	=	11,848,320,000
3,840 acres \times 4,840 \times 9 \times 11 $\frac{1}{2}$ \times 6 $\frac{1}{2}$..	=	40,772,160,000
			52,620,480,000
Deduct for evaporation—			
3,840 acres \times 4,840 \times 9 \times 2 $\frac{1}{2}$ \times 6 $\frac{1}{2}$..	=	2,613,600,000
			50,006,880,000
Deduct $\frac{1}{3}$ rd for unaccountable waste,	16,668,960,000
			33,337,920,000

which is equal to more than 90 million gallons daily—more than 140 gallons per head per diem for the present population, and more than 20 gallons per head per diem for two years for 2,000,000 people.

Enormous as this quantity of water is, the dam to impound it need not be exceedingly high. A reference to the Table on *Plate L.* will show that the surface of the lake would be at 420.00 on datum. Now the bed of the stream, which stands at 298.00 on datum, is solid rock of the best description, and it will be unnecessary to go lower than, if so low as, 295.00 on datum to secure the firmest foundation. If then we suppose the dam to be five feet higher than the surface of the water, its total height would be (425—295 or) 130 feet. But it would be many years, perhaps generations, before such a large quantity of water would

* In 1871, 39 inches fell at Vehar, and this quantity is only little more than one-third the assumed rainfall—*vis.*, 102 inches. On the supposition that the average rainfall in the Tansa Valley bears the same proportion to the actual rainfall in 1871 as the average rainfall at Vehar bears to the actual rainfall there in 1871, the average rainfall in the Tansa Valley ought to be 183 inches. I prefer, however, to base my calculations on moderate data.

**A PROJECT
FOUNDED PLAN
OF THE
RESERVOIR**

E. 2000 FEET - 1 INCH.





be required, and although I have shown what the ultimate height of the dam may be, the height when it is first built need not exceed 95 feet. Even such a dam would impound 9,000 million gallons yearly, or say 25 million gallons daily, or 20 gallons per head per diem for the present population for two years. It would be no use to think of storing a three-years' supply, as 9,000 million gallons are only a small fraction of the average rainfall, so that this quantity of water would probably be received even in years when what are termed failures of the monsoon occurs, but when, in fact, the monsoon does not really fail altogether, but merely gives a supply of perhaps a third or a half of its usual one.

The Tansa Dam, as will be seen by *Plate LI.*, will be a long but not an expensive one. The portion of it which must be high (and this is the important point) would be very short, as the hills rise suddenly to an elevation on one side of seventy, and on the other of ninety feet.* With the exception of the Toolsee Dam, the Tansa has the most favorable section of all the main dams yet proposed. I would have the dam of one uniform section throughout, and that section to be the one designed by Mr. Rankine. The long low part would give us a surplus of stability,† and in the highest part we should have abundance of strength.

I would pass the surplus water over the low part of the southern end of the dam, which would, in fact, become the waste weir. The water would easily find its way back into the river lower down in the valley by another course. It would also be passed over the northern end of the dam if considered desirable. The waste weir for the Tansa Reservoir will, therefore, cost nothing.

Plate LII. illustrates the method proposed for drawing the water from the Tansa Lake. The designs are for a tower of about the greatest height to which one could practically be built, and for the largest quantity of water which could ever be required for a town. The principle may be applied to the Kennery, or Ewoor, or any other scheme involving a deep lake. The reader is aware that I do not propose to raise the Tansa Dam at first to about 390·00 feet on datum (the dam being 95

* Those who have never had occasion to take out the quantities of masonry in dams of different sections, would be surprised to find how much depends on the length of the high portion. A dam a mile long and 30 feet high will not cost more than a dam one-tenth of its length if the latter is 100 feet high.

† *Vide* paragraph 22 of Appendix B., No. LXVIII., Professional Papers, Second Series. If, indeed, the whole of this Article is studied, the force of my recommendation will be better appreciated.

feet high), nor eventually to above 425.00 on datum (the dam being 130 feet high). The problem to solve is of a very special nature, and this will account for the novel features of the design. We have to draw a large quantity of water under a great head, and to deprive the water of its head *at once*, so that it shall flow off into a channel without pressure. To draw water under a great head by a pipe is easy enough, but the difficulty consists in starting it in a masonry conduit without any head at all.* In order to effect this, I propose to make use of the power which a smaller volume of water possesses to diffuse its pressure when discharged into a much larger volume. I propose to draw the water by large pipes, terminating with their mouths turned upwards in the bottom of a deep enclosed basin. The stream will issue with considerable force into this reservoir, but, meeting the resistance of a great body of water above it, the pressure will be diffused, and, as by regulating the sluices, no more water will be permitted to enter the basin than it is desirable that the channel should convey away, the level of the water in the basin will be always kept at one level. If it is considered advisable afterwards, arrangements may be made for straining the water between the basin and the other channel.†

Instead of towers for drawing off water, standing in the middle of a lake, which it is so difficult to keep water-tight, and from which it is impossible, after the works have once been completed, to increase the supply,‡ I am satisfied the proposed method will be found more satisfactory. It is, in fact, the method submitted by me to the Bench in 1870, for drawing off water from the Toolsee Lake, but the design is modified to suit it to any amount of pressure, and to the water flowing off in a channel instead of in a pipe.

A spot on the margin of the lake, where the rock is of a sound descrip-

* I am not aware of any instance where a large quantity of water is drawn under these peculiar conditions, nor do I know of any work on hydraulics which treats of this question.

† In the Glasgow Water Works, when the water in Loch Katrine stands at even its raised level, the average pressure with which it issues into the channel is but 10 feet, and at low water the pressure is as little as 4 feet. But we have to deal with a pressure of from 25 to 80 or even 100 feet, dependent upon which project the Bench decide upon and up to what level it is determined to impound water in the particular reservoir which is approved.

‡ This is not shown in *Plate LII.*, but any one can see how easily it could be accomplished by putting gauze strainers over the mouths of the channels.

§ This is our great difficulty at Vehar. We cannot lay down a second pipe from the tower, and we are entirely dependent on the security of a single main running under the dam. If anything happens to this, a state of things frightful to contemplate would follow. *Vide* note to page 301 of No. LXXVII., *Professional Papers, Second Series.*

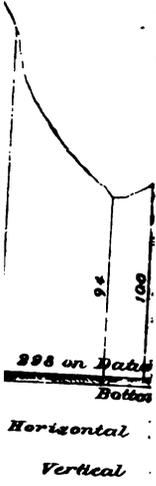

Ordinates from Vertical line

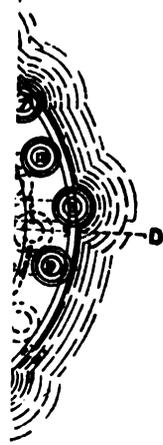

feet high
feet high
will acco
large qua
its head
To draw
difficulty
all.* In
smaller v
into a m
terminati
enclosed
reservoir,
the press
water wil
channel
always k
ments m
other cha

Instea
lake, whi
possible,
supply,†
tory. It
for draw
to suit it
channel i

A spo

* I am no
conditions,

In the
the average
sure is as li
dependent
pound wate

† This is
ting gaus

‡ This is
we are enti
happens to
of No. LXX

ISA PRO

LET W

32 FEET TO A

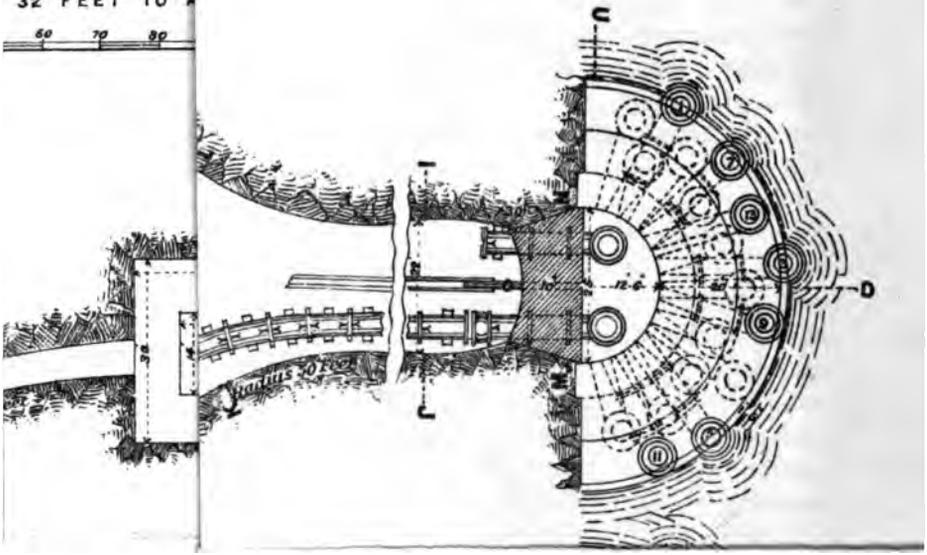
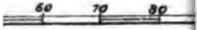

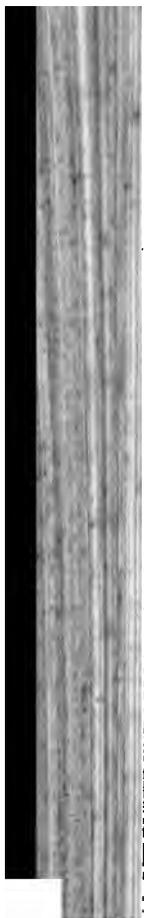

tion, should be selected, and the tower should be built into the rock,* and be of a semi-circular form, so that the pressure may be thrown on the hill. The thicker the masonry of the tower the better, so that it may resist the creeping effect of the water. From the bottom of this tower a tunnel should be driven of such dimensions as will admit of the number of pipes that may ultimately be required, being laid in it. Over the mouths of the pipes which draw the water from the lake into the tower, fine gauze strainers, similar to those in use at Vehar, may be used.

The advantages of the system are obvious. The supply could be increased at any future time by laying down another pipe—or any number of pipes—between the tower and the basin from which the channel starts. If a pipe in the tunnel were to burst, or repairs of any kind had to be carried out, all that would be necessary would be to close the mouths of the inlets in the lake, and to let the tower empty itself. Workmen could then descend to the bottom, or into the tunnel, and do what might be required.

In *Plate LII.* the towers are in duplicate. This, although not necessary, would be the most convenient arrangement. Of course, the sizes and the number of pipes must be modified to suit the particular case. That which I have dealt with, is perhaps the most difficult that would ever occur in water-works for the supply of a town. The pressure of the water is as much as 120 feet, which is not likely to be met in practice, and the pipes are 4 feet in diameter, and capable of delivering an enormous supply.

From the Tansa Lake I would bring the water to the proposed Koorla Reservoir, partly by channel and partly by iron pipes.† I say "partly," because the case is different to that of the Kennery, Toolsee, or Ewoor Schemes. In these the features of the country admitted of a channel or tunnel being carried to Koorla with hardly any break on the line, but in the case of the Tansa it must be remembered that the lake is more than 50 miles from Bombay, and there is no continuous range of hills extending from the reservoir to Salsetta. There are several ranges most conveniently situated for our purpose, but there are gaps between them, and, to get the water from a channel on the top of one range into a channel on

* This is not shown as clearly as could be wished in the *Plan*, but it is very necessary. The rock in the Tansa valley is thoroughly sound.

† *Vide* Index Map in No. LXXVIII., Professional Papers, Second Series, and *Plates LIII.* and *LIV.*

the top of the next, we should be compelled to cross the valley between. This could only be done by carrying the water under pressure in pipes laid across the valley, or by rock syphons which I will suppose may prove unsuccessful. An accurate survey of the entire line from the Tansa to the Koorla Reservoir has been made, and a section of it is given in *Plates LIII. and LIV.*, from which it may be gathered that, altogether, about $29\frac{1}{2}$ miles of channel and 15 miles of pipes would be required. I think one foot a mile a good slope for the former, and five feet a mile about the best relative one for the latter.* On these data, the total fall of the entire line will be $(29\frac{1}{2} \text{ feet} + 15 \times 5 \text{ feet} =) 104\frac{1}{2}$ feet, so that at whatever level the water may start flowing from the Tansa Lake, it will reach the Koorla Reservoir $104\frac{1}{2}$ feet below that level.

The water might be drawn from the Tansa Lake at as low as 350-00 feet on datum, but I should prefer to draw it at 360-00. Supposing then that this latter level be decided upon, the water would reach the Koorla Reservoir at $(360 - 104\frac{1}{2} =) 255-50$ on datum—the same level as that fixed for the water from either Kennery or Ewoor. But it is the bottom of the channel which would be at this level, and the surface water, supposing the channel were four feet deep, would be at $(255\frac{1}{2} + 4 =) 259-50$ feet on datum, the highest level at which it is proposed that the water shall stand in the Koorla Reservoir for the Kennery and Ewoor Projects.

I will now show how the channel would run with reference to the Vehar Lake. The lake is $4\frac{1}{4}$ miles nearer than the Koorla Reservoir to the Tansa basin, and the portion of the line between it and Koorla would consist of $3\frac{1}{4}$ miles of conduit, with a rise from Koorla of $3\frac{1}{2}$ feet, and of three-quarters of a mile of syphon, with a rise of $3\frac{3}{4}$ feet. The total rise in the conduit and syphon together would be 7 feet, and, therefore, the channel would be 7 feet higher when it reached Vehar than it would be at Koorla. At Koorla, we see it would be at 255-50 on datum; therefore, at the Vehar Lake, it would be at $(259-50 + 7 =) 262-50$, which the reader will remember to be the exact level of the surface of the lake when it is full. Thus the arrangements would be such that the channel would have a perfect command of our present reservoir, and at any time water from the Tansa could be discharged into it to keep it full. This is a very important consideration to bear in mind in carrying out new works.

* The reader will remember that this is the general slope I have adopted in the Kennery and Ewoor Projects. The slope Mr. Bateman has given to the Glasgow channel is 10 inches per mile, and to his syphons 5 feet per mile.

CROSS SECTION OF CONDUIT

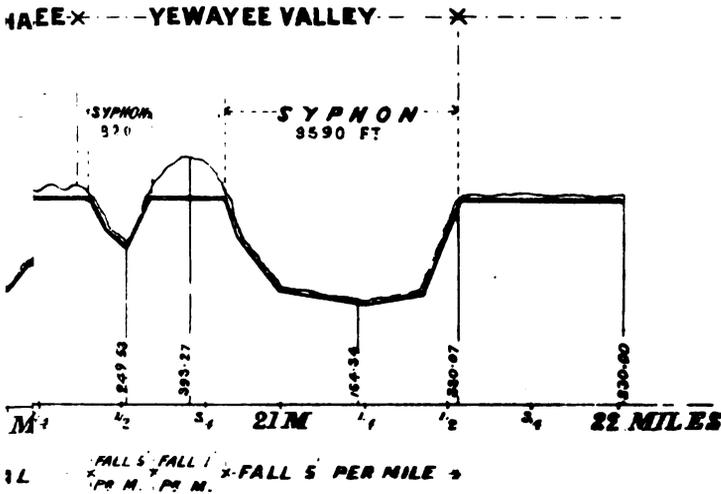
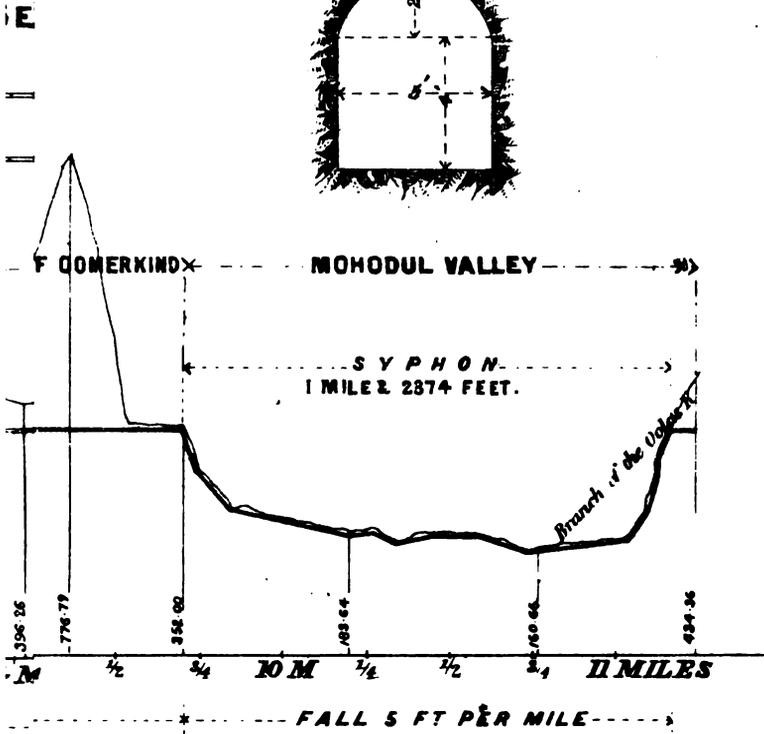
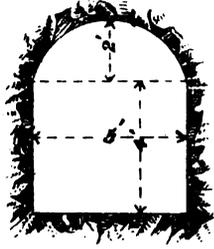

FALL 5 PER M. FALL 1 PER M.



If the water were drawn from Tansa at 350·00 on datum, it would be best to reduce the slope of the channel from a foot to 10 inches a mile, and the fall of the syphons from 5 to $4\frac{3}{4}$ feet per mile, so as still to ensure its reaching Vehar with a command of the lake. Or, if the water were drawn at 360·00 on datum, and it were considered advisable to have the service reservoir even 10 feet higher than proposed by me, these slopes given to the conduit and syphons would bring the supply to Koorla at 369·50, and the water would, on its course, pass the Vehar Lake at 10 feet above the surface of the latter.

The entire line from the Tansa to Koorla has been accurately surveyed, and *Plates* LIII. and LIV. are sections of the line reduced from the large plans in the Municipal Office. There is no doubt, therefore, of the correctness of the facts stated.* I particularly request that these *Plates* may be looked at closely.† The line has been arranged to avoid as much as possible long tunnels and deep shafts. As a rule, the tunnels will be from 200 to 300 yards long, or less if considered desirable, and the shafts would be about 20 or 30 feet deep, or less, also, if deemed more advantageous. I thought this about the least depth to ensure good sound rock. Excepting through five hills, it is quite clear the line is most favorable. These hills occur—the first at the 3rd milestone; the second and third between the 8th and 10th milestones; the fourth at the 12th milestone; and the fifth at the 23rd milestone. The first hill—viz., that at the 3rd milestone, is really the worst obstacle, but even here two shafts 150 feet deep would reduce the headings on each side to about 300 yards.‡

* No plan of the line is given in this report. It has been omitted simply on grounds of economy. The number of *Plates* has already far exceeded what I ever contemplated. An accurate survey on a large scale may be consulted in the Municipal Office by those who desire detailed information. For the general reader, the Index Map, in No. LXXVIII., Professional Papers, Second Series, gives all the necessary facts.

Those who have never conducted a survey for a long line of this kind—i. e., for a high level water channel, and in a hilly country covered with the densest jungle, where often an advance of fifty feet cannot be made without felling large trees, and clearing a path through closely matted brushwood, can hardly realise what an amount of labor and exposure is involved to secure the best course. Two and three lines have to be surveyed and levelled before the best can be decided on, and this again has to be modified, re-surveyed, and re-levelled in consequence of facts brought to light subsequently. It is these things which render survey work for water supply so very expensive in Bombay.

† I had intended to give the position of every shaft, in order to show how favorable for tunneling the line would be, but these *Plates* were done in Bombay while I was in England, and they could not, of course, be subjected to my final corrections. The reader must be indulgent for omissions of this nature.

‡ The first hill through which Mr. Bateman so boldly tunnelled to take the Loch Katrine water to Glasgow had, besides several others, five shafts on an average depth of 150 yards.

The hills between the 8th and 10th milestones might be tunnelled through with a shaft at each end, and one in the middle. None of the shafts need be more than a few feet deep. The long tunnels in these cases would probably be preferable to sinking deep shafts. The hill at the 12th milestone looks the most formidable of all, but it is the least so. In fact, it is as favorable as any part of the line, because horizontal shafts* can be obtained of any required depth, and at convenient distances apart. A shaft 100 feet deep in the middle of the hill at the 23rd milestone will remove all difficulty here.

Overflows would be constructed at numerous points along the line to discharge the water if at any time there were an obstruction in the conduits or syphons; and numerous ventilating man-holes could be left, if considered desirable, at all points where shafts had been sunk.

Only three aqueducts would be required in the whole length (29½ miles) of channel, and this circumstance is, in my opinion, extraordinarily favorable. These works, moreover, would be of such an insignificant kind that I need not speak of them further.

The most formidable obstacle on the entire line would be the Tannah Creek, but this is incidental to every project with a reservoir out of Salsette, and, in fact, to every project for a large supply of water, which cannot, as the reader now knows, be obtained in Salsette. The cheapest way to overcome this obstacle, would be to tunnel under the creek at a depth of from 50 to 100 feet below the bed. I have calculated the cost of several kinds of iron aqueducts over the water, but find they would all entail more expense than a simple tunnel with a cast-iron pipe laid in it.†

I will now point out what I delayed doing in a previous part of this report, when I mentioned that I should prove the disadvantageous position of the Shewla Reservoir. If I have made myself clear in my article on 'Masonry Conduits' (*vide* No. LXXVI., Professional Papers, Second Series,) it must be evident now to the reader that, *ceteris paribus*, that must be the best reservoir which will admit of the water being brought to

* These cannot be shown in a section, but those who care to be satisfied on this point can refer to the plan of the line in the Municipal Office.

† If the Government were desirous to improve the high road to the Deconan by a bridge over the creek, and would meet the Bench half way by sanctioning a portion of the total outlay required for a bridge and aqueduct combined, no doubt this would be the cheapest and best mode of carrying the water across; but if the entire expense of such a work is to fall on the Bench, a tunnel will be cheaper. Perhaps the Government might consent to make over the tolls to the Bench, and to do away with the ferry. It might be worth while then to construct a bridge and aqueduct.

Bombay by a high level channel instead of in a pipe. In fact, the only hope of carrying out a large scheme will depend upon our being able to dispense as much as possible with pipes.*

In the Index Map in No. LXXVIII., Professional Papers, Second Series, are shown the best lines along which the water should be brought from both the Tansa and Shewla Basins. Now the total length, by a careful survey, of the line from Tansa to Koorla is, as already mentioned, $44\frac{1}{2}$ miles, of which $29\frac{1}{2}$ miles would be channels, and 15 miles would be pipes. The total length of the line from Shewla to Koorla is 47 miles, of which 21 only would be channels and 26 pipes. The line from Shewla, therefore, would be not only $2\frac{1}{2}$ miles longer than that from Tansa, but there would be 11 miles more of pipes required for it than for the latter.

Nor is this all. From the same sized pipe in the two cases, we should obtain more water from Tansa than from Shewla; or, in other words, a larger pipe, to convey the same quantity of water, would be required from the latter than from the former. The reason is obvious. We could not get so great a fall for the pipe. I have shown that the total fall of the line from Tansa to Koorla is $104\frac{1}{2}$ feet, that the $29\frac{1}{2}$ miles of channel on the Tansa line would have a slope of one foot per mile, and that the 15 miles of pipe would have a fall of 5 feet per mile. The Shewla Lake being about 20 feet higher than the Tansa, the available fall, supposing the water were drawn from as high as 380.00 on datum, would be $124\frac{1}{2}$ feet. If we gave the channel, of which there would be 21 miles, a fall of one foot per mile, we should have $103\frac{1}{2}$ feet left for the 26 miles of pipe. Thus the fall per mile for the latter would be four feet instead of five, as in the case of the Tansa line. The fall being less; the discharge would be less, or, to obtain the same discharge, the size of the pipe and the thickness would have to be increased—i. e., the cost enhanced.

If, in order to get the same slope for the pipe from Shewla as that from Tansa, it were decided to draw the water from a higher level, it would have to be drawn from $26\frac{1}{2}$ feet higher, or from 306.50 on datum. But to do this would be to leave only $11\frac{1}{2}$ feet depth of water in the lake, for I have already mentioned that the dam cannot be made higher than to

* I beg the reader at this point to refer to the note on page 163 of No. LXXVI., Professional Papers, Second Series, (and especially that portion of it regarding the Shewla Scheme), where he will see the enormous cost in every project of the works for bringing water to Bombay as compared with the cost of storing it. The estimates in this report illustrate the same point, and although the cost of those works has been greatly reduced.

impound water up to about 418·00.* The hills on the sides of the dam are not much above this level.

In addition to this, it will be seen from the map, that the line from Shewla has to cross two large rivers, the Kalloo and the Bhatsa, just below their junction, and, to effect this, special and costly arrangements would be required.

A reference to the map, moreover, will show that the pipes on the Tansa line would be situated not far from a metalled road which, being indeed the high road to the Deccan, is open at all seasons of the year. Thus the facilities of carriage would be great, and the cost comparatively small. Again, the site of the Tansa Dam itself is but five miles from a station (Atgaum) on the Great Indian Peninsular Railway, and the road from the station to the dam, running as it does on high ground, could be always open,† so that a perfect communication could be maintained even in the monsoon, and materials could easily be carried wherever they might be required.

On the other hand, the Shewla Reservoir is 15 miles from the nearest station, and there is no metalled road in its direction. The track, such as it is, runs, every now and then, over swamps which, as the Engineer Officers of the Municipality have found to their cost, are impassable during rainy weather. It is really the case that for four months in the year no cart traffic takes place between the large town of Moorbar and the railways.‡

I have referred in a previous part of this report to the valuable nature of the ground which would be swamped by the Shewla Lake. Now this point becomes, when carefully inquired into, one of great importance. It must be remembered that as many as 4,000 acres would have to be taken up if a reservoir were formed either at Shewla or in the Tansa Valley. For the Kennery, Toolsee, Ewoor, and Tansa Schemes, the land required would consist merely of jungle; but for the Shewla Lake the entire water-spread is almost all under cultivation for rice§ and, unless the owners were

* This is the height of the water level proposed by Mr. Aitken.

† Even a tram could be laid, if considered desirable, without any risk of its having to be closed in rainy weather.

‡ Such hard labor as it considered for bullocks to work in this district in wet weather that, in order to prevent their cattle being seized for the purpose, many of the villagers, immediately the monsoon sets in, take off the wheels from their carts and bury them. The Municipal Officers were always made welcome to the carts, but invariably found them without wheels.

§ I am told that the rice produced in the Shewla Basin and all about Moorbar is of a superior quality, and fetches a higher price in the market than most other kinds, and that the land-owners in Moorbar and the surrounding villages are very tenacious of their fields.

liberally dealt with, they would not part with their properties. Whatever may be the value of jungle, it must be clear to the most ordinary understanding that land, which has been brought into a high state of cultivation by the labor of years, must be four or five times as valuable; so that if Rs. 50 an acre be sufficient to pay for jungle, Rs. 200 an acre will not be too high a price to pay for an acre of the best paddy. At these rates the cost of the land for Shewla Lake would be six lakhs of rupees in excess of that which we should have to pay for the land in the Tansa Valley. Moreover, nearly all the latter belongs to the Government, who, I have no doubt, would, with the prospect of the beneficial effects to be produced in the surrounding country by a large water scheme, grant it for a merely nominal sum, especially as it yields them nothing at the present moment; whereas the land at Shewla belongs to well-to-do people, who are fully alive to the value of their properties, and who would most certainly demand the utmost compensation for their loss, or proceed to law to obtain it.

Thus then the advantages of the Tansa over the Shewla Project for a gigantic project, may be summed up thus :—The gathering ground of the Tansa, and, therefore, the supply to be obtained from it, is nearly double that to be obtained from Shewla. The capacity of the reservoir is greater. The line by which the water would be conveyed to Bombay is $2\frac{1}{2}$ miles shorter. Only 15 miles of pipe would be required to reach the Koorla Reservoir in place of 26 miles in the case of Shewla. The slope which could be given to the Tansa pipe is greater than that which could be given to the Shewla pipe, without sacrificing other advantages; or, if the same slope were to be given to the Shewla pipe, the capacity of the reservoir would have to be so reduced as to make it but a small one. The communications between Tansa and Bombay are nearly completed already by railway, and the pipes could be carried close to their destination along a first-class metalled road; whereas the communications between Shewla and Bombay are most incomplete at the best, and closed during the monsoon, and the pipes would have to be carried to their positions along country tracks, and over low swampy ground. And, lastly, the land required for the Shewla Lake would cost many lakhs of rupees in excess of what would have to be paid for the land in the Tansa Valley.

When all these points are considered, it will be found on calculation that the difference in the first cost of the two lines would be from 15 to 20

lakhs of rupees, dependent on the quantity of water it might be decided to convey to Bombay, and the difference in the after-cost, as the works required extension and more water had to be brought to Bombay, would be enormously more.

I trust it will now be seen that the facts brought to light by the surveys and investigations undertaken by me have justified the rejection of the Shewla reservoir for a large scheme of water-supply. I will now pass on and complete my explanation of the Tansa project.

I need not describe the service reservoir at Koorla, which would be the same as for the Kennery or Ewoor Projects,* and the details of which are given in *Plate XXXIX*. The pipes from Koorla to Bombay would run along the course shown in *Plate XL* for the Kennery line. The size of the pipe would of course depend upon the quantity of water it was determined to deliver in Bombay. In order the better to effect a comparison between the several Kamun projects and the Tansa Project, I have estimated for pipes to convey various quantities of water to Bombay.

I have already mentioned that the land which would be covered by the Tansa Lake is nearly all jungle, and similar in character to that which would have to be taken up for any of the Salsette projects. The entire watershed, moreover, consists of rocks of primitive formation, and the water, therefore, would be of the same quality as that supplied at present to Bombay. The villages, which would be swamped by the water, consist in every case of merely a few straggling huts occupied by men of the poorest class, and it would cost little to compensate these men for their dwellings, which consist merely of mud walls thatched over with the grass growing close to them.

The following are estimates of the scheme for 18, 20, and 26 gallons per head per diem for the present population :—

Estimate No. 1.

COST OF TANSA SCHEME.

Dam to impound at first 9,000 million gallons, and supply to be 8½ million gallons daily :—

* The reader will have observed that the Kennery, Ewoor and Tansa Projects are all on the same system. The channel for each reaches the service reservoir at the same level; the surface reservoir suits each scheme equally well, and the pipe to Bombay would run along the same line for each.

	RS.
Dam 95 feet high, but constructed so as to admit of its being raised from time to time, so as ultimately to be 130 feet high, containing 4,496,000 cubic feet of rubble masonry, at Rs. 25 per 100 cubic feet,	11,24,000
29½ miles of channel, with a waterway 5 feet wide by 4 deep, at Rs. 80,000 a mile,	23,60,000
15 miles of syphon pipe, between Tansa and Koorla, 36 inches in diameter, and 1½ inch thick, delivering 8½ million gallons daily, and weighing 1,020 tons per mile, or 15,300 tons, at Rs. 160 a ton,	24,48,000
9½ miles of pipe from Koorla to Bombay, 28 inches in diameter, and 1 inch thick, delivering 8½ million gallons daily, and weighing 720 tons per mile, or 6,840 tons, at Rs. 160 per ton,	10,94,400
No waste weir required (<i>vide</i> page 333).	
Outlet works,	1,50,000
Tunnel under Tannah Creek, about half a mile long, ..	3,00,000
Koorla Reservoir, and works there,	3,00,000
	77,76,400
Add 10 per cent. for contingencies, say,	7,77,600
Land, 2,420 acres of jungle for reservoir,* 32 acres for syphons and pipes, at Rs. 50 each,	1,38,000
Total,	86,87,000

Or, say, 87 lakhs for 13 gallons per head per diem for the present population.

Estimate No. 2.

Dam to impound as before 9,000 million gallons. Supply to be 13 million gallons daily:—

	RS.
Dam as before,	11,24,000
29½ miles of channels, as before,	23,60,000
15 miles of syphon pipe, between Tansa and Koorla, 42 inches in diameter, and 1½ inch thick delivering 13 million gallons daily, and weighing 1,364 tons per mile, or 20,460 tons, at Rs. 160 per ton,	32,73,600
9½ miles of pipe, from Koorla to Bombay, 33 inches in diameter, and 1½ inch thick, delivering 13 million gallons daily, and weighing 924 tons, per mile, or 8,778 tons, at Rs. 160 per ton,	14,04,480
Carried forward,	81,62,080

* This will be sufficient at first.

						RS.
Brought forward,						81,62,080
No waste weir is required.						
Outlet works, as before,	1,50,000
Tunnel under Creek, as before,	3,00,000
Koorla Reservoir, and works there, as before,				3,00,000
						89,12,080
Add 10 per cent. for contingencies, say,				8,91,920
						98,04,000
Land as before,	1,33,000
Total,						99,37,000

Or, say, 99½ lakhs for 20 gallons per head per diem for the present population.

Estimate No. 3.

Dam to impound at first 9,000 million gallons, and supply delivered to Bombay to be over 17 million gallons daily :—

						RS.
Dam as before,	11,24,000
Channel as before,	23,60,000
15 miles of syphon pipe 48 inches in diameter, 1½ inch thick, delivering over 17 million gallons daily, and weighing 1,760 tons per mile, or 26,400 tons, at Ra. 160 a ton, ..						
						42,24,000
9½ miles pipe from Koorla to Bombay, 39 inches in diameter, and 1½ inch thick, delivering over 17 million gallons daily, and weighing 1,260 tons per mile, or 11,970 tons, at Ra.						
						19,15,200
Outlet works, as before,	1,50,000
Tunnel under Creek, as before,	3,00,000
Koorla Reservoir and works there, as before,				3,00,000
						103,73,200
Add 10 per cent. for contingencies, say,				10,37,800
						114,11,000
Land as before,	1,33,000
Total,						115,44,000

Or, say 115½ lakhs for 26 gallons per head per diem for the present population.

H. T.

No. XCI.

THE KAMUN PROJECT FOR "THE WATER SUPPLY OF
BOMBAY."

[*Vide* Plates LV. to LVIII.]

BY MAJOR HECTOR TULLOCH, R.E.

THE general position and extent of the Kamun Valley will be seen on the Index Map in No. LXXVIII., Professional Papers, Second Series. It is admirably situated for the storage of water. The lower part of the basin is exceedingly flat as may be gathered from the fact (*vide* Table on *Plate* LV.), that a dam impounding only 60 feet depth of water would form a lake of about four square miles, or nearly double the area of Vehar, and one impounding 100 feet depth of water, would have an area of more than six square miles, or nearly three times that of Vehar. The best, in fact the only site for the main dam is at a spot, *vide* *Plate* LV., immediately below the junction of the two principal streams. These are fed by the rains which fall on the Toongar Hills, and to judge by their size, they must bring down a very large quantity of water.

As already mentioned, the tide ascends to the very site of the dam, where the bed of the stream is at 80.00 feet on datum. If a reservoir were formed in this valley, it would be necessary to stop up also two gaps in the ridge of hills on the south-west margin of the lake. The length and depth of the required dams may be gathered from *Plate* LVI. The area of the watershed above the site of the main dam may be taken at 20 square miles, or 12,800 acres. I have fixed upon 140.00 on datum as the level below which the water should not be drawn. A large quantity would be contained in the reservoir even below this level, but my ob-

ject is to draw the water from as high a point as possible, in order to save the cost of pumping, which, it must be clear to every one, would be necessary before the Kamun water could be supplied to the town. It is true that by drawing the water at a lower level there would be the partially compensating advantage of lower dams, but I have calculated, and find it would be cheaper to construct dams to enable us to draw at 140·00 on datum, than to construct lower ones, which would enable us to draw at, say, 120·00 on datum, but would at the same time compel us to pump the water the extra 20 feet. It would be even cheaper to draw the water at a higher level than 140·00 on datum, but then the dams would become higher than I think they should be for the kind of foundation we can find for them.

On the same data* as we applied to the other valleys, and taking the average area of the lake at 5 square miles, the quantity of water obtainable from the Kamun Valley would be:—

3,200 acres × 4,840 × 9 × 8½ × 6½ =	7,405,200,000
9,600 acres × 4,840 × 9 × 4½ × 6½ =	11,761,200,000
		19,166,400,000
Deduct for evaporation—		
3,200 acres × 4,840 × 9 × 2½ × 6½ =	2,178,000,000
		16,988,400,000
Deduct ¼rd for unaccountable waste, =	5,662,800,000
		11,325,600,000

—i. e., more than 31 million gallons daily, or, say, 48 gallons per head per diem for the present population.

It will thus be seen that so far as quantity is concerned, the supply to be obtained from this low level basin of Kamun is abundant. The facilities for storing the water are also favorable. By reference to the Table on *Plate LV.*, it will be seen that to hold a one-year's supply, the surface of the lake must be at about 155·00 on datum—to hold a two-years' supply, say (22,000 million gallons), it must be at 166 on datum—and to hold a three-years' supply (33 million gallons), at 175·00 on datum.

The bed of the stream at the site of the main dam is 80·00 on datum, and it would be necessary to go twenty feet below this for a solid foundation, in which case the bottom of the dam would be at 60·00 on datum. If the dams were carried in each instance five feet above the level of the

* I believe the rainfall in the Kamun Valley to be considerably greater than that at Vehar. In 1871, 51 inches of rain fell at Kamun, while 39 only fell at Vehar. But it will be better perhaps not to be guided by the results of a single year.

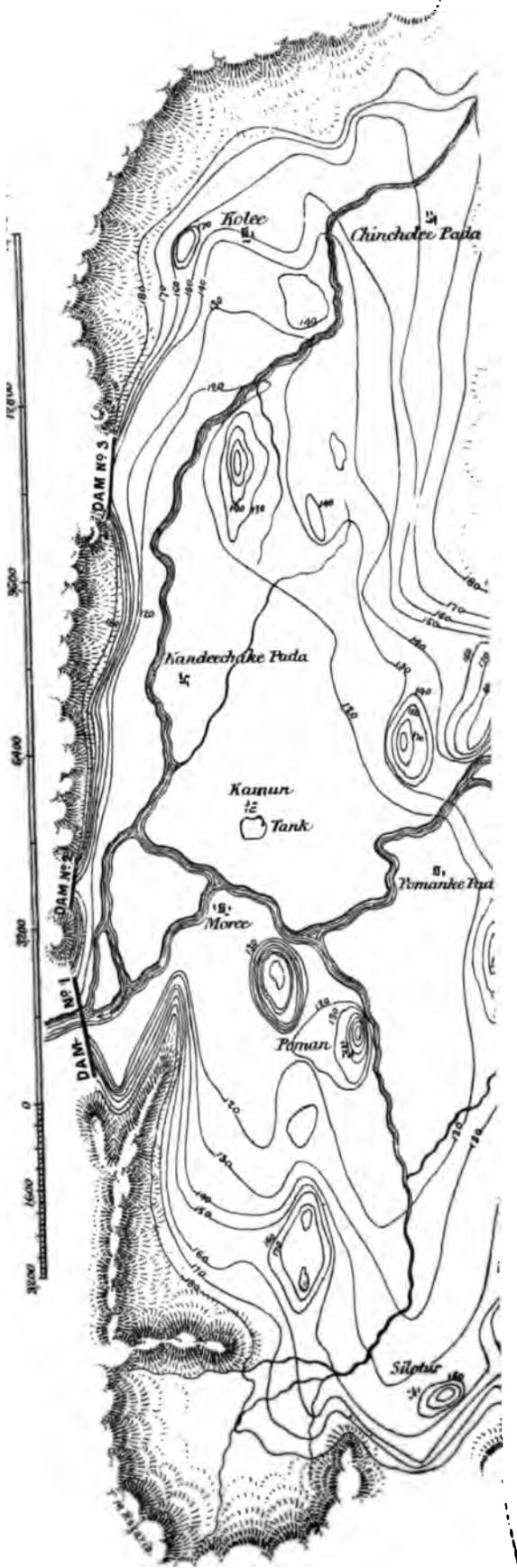
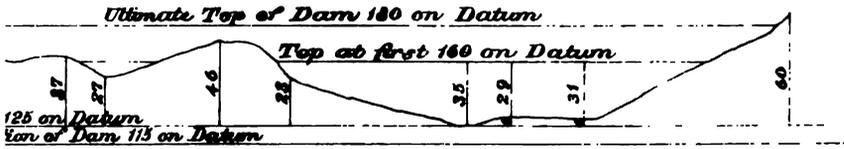
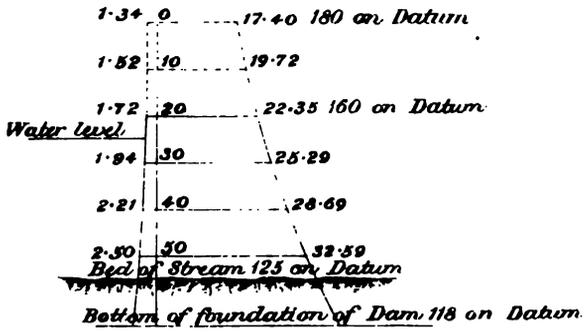



PLATE LVI.



Feet



120 Feet

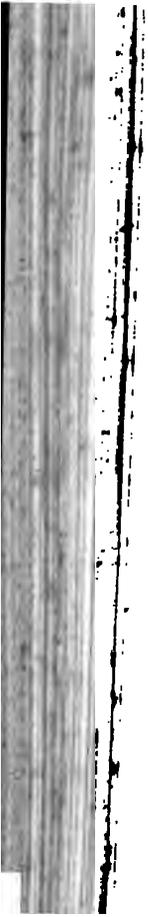

water, the height of the main dam to impound a one, two, and three-years' supply, would be as follows :—

	feet.
To impound 11,000 million gallons, or a one-year's supply (160 — 60),... ..	100
To impound 22,000 million gallons, or a two-years' supply (171 — 60),... ..	111
To impound 33,000 million gallons, or a three-years' supply (180 — 60),... ..	120

Of course it is manifest that, with so large a quantity as 48 gallons per head per diem for the present population, it would be absurd at first to store more than a year's supply. Even this would be in excess of what we have in the Vehar Lake when full. In the estimates, therefore, of the Kamun Project, I shall assume that the dams are not to impound at first more than this quantity of water, but they must be constructed so that they may be raised at any subsequent period to impound a full three-years' supply.

The cheapest mode of bringing the water to Bombay would, beyond all doubt, be by a conduit, and it must be evident to the reader that, considering the low level of the reservoir, it would be impossible to supply the town without pumping up the water by artificial means. Now, it is an important question in this scheme where the water should be pumped. It might be pumped at the Lake itself, or at some point between Kamun and Koorla, or at Koorla, where we could have a service reservoir for contingencies, or in Bombay. If it were pumped at any point between Kamun and Koorla, I think the best place would be near the Ewoor Lake, and I would raise the supply, not by steam, but by the water in the latter reservoir. Although this will be considered by many a most novel proposition, still, when the estimates are submitted, the scheme will not be found to compare unfavorably with the others; and at the time of my investigation, when I was not aware how very expensive the Ewoor dams would turn out to be, this seemed the most promising of all the projects. However, the reader shall judge of it for himself.*

I have already proposed to draw the water from the Kamun Reservoir

* When I had to leave Bombay so suddenly, both the Ewoor and Kamun Projects were under investigation, and, not having all the facts connected with them before me, I could not then decide finally which of the Kamun Projects would be the cheapest. Had I stayed, I would probably have completed a survey for a low level conduit from Kamun to Bombay; but the estimate submitted further on will show the Bench what the cost of a scheme, if the water is taken to Bombay and pumped up there, will be.

at 140 on datum, and I would adopt the same size of conduit in each of the Kamun projects, as I have in all the other schemes—viz., one with a waterway five feet wide and four deep. And I would give it the same slope as before,—viz., one foot per mile.

There would be $9\frac{1}{2}$ miles of conduit at this slope, between Kamun and Ewoor, and half a mile of pipes with a fall of $2\frac{1}{2}$ feet under the Tannah Creek.* The conduit, therefore, starting at 140, would reach Ewoor at 128 on datum. Here the water would be pumped 100 feet, as I will presently explain at greater length, and then proceed in a conduit with the same slope as before, till it reached the Lower Koorla Reservoir, *vide Plate LVIII.*, a distance from Ewoor of $9\frac{1}{2}$ miles, at 218 $\frac{1}{2}$ on datum.

The only obstacle of consequence on any line of conduit from Kamun to Bombay is the Tannah Creek, and I think this could best be overcome by a tunnel. Vertical shafts should be sunk† on each side to a depth of not less than 50 feet below the bed of the stream, which at the site is solid rock, and tunnels should then be driven from each end to meet in the middle. The width of the stream is but little more than a quarter of a mile, and I know of nothing to render the work unsuccessful. A tunnel would be cheaper than an aqueduct over the stream, as the current in this part of the creek is very strong, and the erection of piers would be more than ordinarily expensive.‡

Now, as to the works at Ewoor, I have already shown that the Ewoor Valley is very badly situated for the storage of water, but there is one point in connection with the scheme which, if the Kamun Project were contemplated, might render it advisable to carry out the two together. This point is that, although the water to be obtained from Ewoor would be small in quantity, yet it would be at so great an elevation as to be a most useful mechanical power for raising the Kamun water to a higher level. The yearly supply—2,400 million gallons—would lie at an average height for use of, say, 470 on datum.§ Now the Kamun water could, as I have

* *Vide Oolas River, Plate LVII.*

† In *Plate XLIV.*, they are shown inclined, but this is an accidental error, and the tunnel is not put at a sufficient depth below the bed of the river.

‡ If any aqueduct were adopted, this suspension principle seems at first sight the best to apply, in order to obviate the necessity of piers, but there are great objections to this, as any one will find who goes into the subject.

§ I am supposing that at least a two-years' supply is stored in Ewoor; and, if this were done, the water used every ordinary year—*i. e.*, when there was no failure of the monsoon—would lie (*vide Pages 246 and 247 of No. LXXXI., Professional Papers, Second Series*) between 481 and 464 on datum, or at an average level of 472 $\frac{1}{2}$. I prefer, however, to say 470 as in the text.

JUNCTION OF CONDUIT

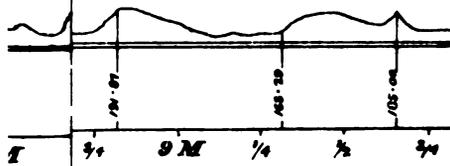

... F.A.L.

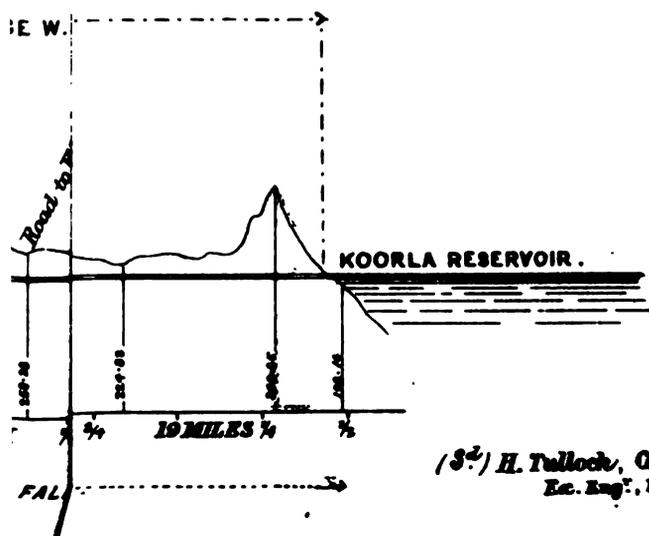

(S^d) H. Tullock, Capt., R.E.,
 Ec. Eng^r, Municipality.



shown be brought to Ewoor at 128 on datum. Which should, therefore, have a power equal to 2,400 million gallons falling through (470—128), 342 feet. Theoretically, this should raise three times the quantity more than 100 feet high, but there is always a considerable loss of power even in the best engines. Suppose turbines, which are the most approved form of water engine, were used, and a loss of power of 25 per cent. took place, and suppose that, instead of dropping the water down 342 feet, which would necessitate its being wasted, we dropped it 242 feet, and let the water, after doing its useful work, flow off with the Kamun water in the same channel as the latter, we should then be able to raise, $(\frac{3}{4} \times \frac{2,400 \times 242}{100} =) 4,356$ million gallons, which, with the Ewoor water (2,400 million gallons), would give us a total supply of, say, 6,756 million gallons yearly, which is about $18\frac{1}{2}$ million gallons daily,* or, say, $28\frac{1}{2}$ gallons per head per diem for the present population.

If more water than this quantity were required, there would be no help for it but to pump it by steam. The Toolsee water would be too small in quantity to use in the same way, and more than one pumping station would be objectionable.

Of course, if such a scheme as the above were ever contemplated, it would be better to impound a full three-years' supply from the very beginning in the Ewoor Lake,† as there would then be very little risk of the supply falling short through the failure of the monsoon. Without water in the Ewoor Lake to pump up the Kamun water, there would be no supply to Bombay.

The outlet works at the Kamun Reservoir would be on the principle of those proposed for the Tansa Project, *vide* Plate LII., and the waste weir would be a work of easy construction. The water might be passed into the lower part of the valley, or at several points over the range on the south-west margin of the lake, or into the Payah Valley, *vide* Index Map in No. LXXVIII., Professional Papers, Second Series, close to the spot from which the conduit would start for Bombay.

The details of the Lower Koorla Reservoir will be best understood by

* The channel I propose—viz., one with a waterway five feet wide and four deep, would, with the slope to be given to it—viz., twelve inches per mile—carry away only $17\frac{1}{2}$ million gallons, so that there would be about a million gallons left. Instead of making the conduit a little larger, or giving it a greater slope to carry away the full $18\frac{1}{2}$ million gallons, I would retain the one million for the use of the towns of Tannah and Bhandoop.

† In this case, as the water would lie about 18 feet higher, we should be able to pump up about one million gallons more, so that the total supply would be about $19\frac{1}{2}$ million gallons daily.

reference to *Plate LVIII*. It is intended simply for service purposes, from which the water would be sent to Bombay under pressure. It would be capable of holding nearly 130 million gallons, or, say, about a fortnight's supply at 10 million gallons daily. The dam, although a long one, would not be more than about fifty feet high. The water would be drawn for use on the principle of the system shown in *Plate LII*.

From Koorla a pipe would be laid to Bombay, and its size would of course depend on the quantity of water required by the town. It would follow the same course as the other pipes from Koorla, a section of which is shown in *Plate XL*.

Suppose, however, that instead of using the Ewoor water to raise the Kamun supply, we employed steam; I do not think there would be any advantage in fixing the pumps at Koorla. The choice lies between Kamun and Bombay. The great expense in pumping schemes is that of the coal consumed, which would have to be taken to Koorla by railway; whereas it could be delivered at Kamun by boats, there being water communication all the way between this town and the Bombay harbour. Besides this, there is no compensating advantage in the position of Koorla, whereas there are advantages attached to both Kamun and Bombay.

If the water were brought to Bombay to be pumped, I do not think, considering the levels of the ground even along the best line which the conduit could take across the low lands* between Koorla and the island, and in the island, that it would be advantageous to carry it in at a higher level than about 90 on datum. It might be carried in at 100 on datum, but only at great expense, as I will show. The draw-off point in the Kamun Lake could not well be higher than 140 on datum, and there being 19 miles of conduit with a slope of 1 foot per mile, and half a mile of pipe at a slope of 5 feet per mile, the water could not therefore reach Koorla above about 118½ on datum. From Koorla there would still remain 19 miles of distance to Bombay, and of this length it appears to me that it would be best to have about 4 miles of pipes, and 5½ of conduit. If we had a conduit all the way from Koorla to Bombay, along the 4 miles where I have proposed to lay pipes, we should require a masonry aqueduct standing from 20 to 25 feet above the surface of the ground, and such a work

* *Vide Plate XL*, where it will be seen that along the 2nd, 3rd, and 4th miles, the lands are not above 87 on datum, or just about the level of high water, and for part of the 5th and 6th miles also the ground is very low.

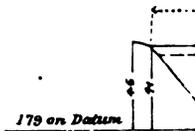
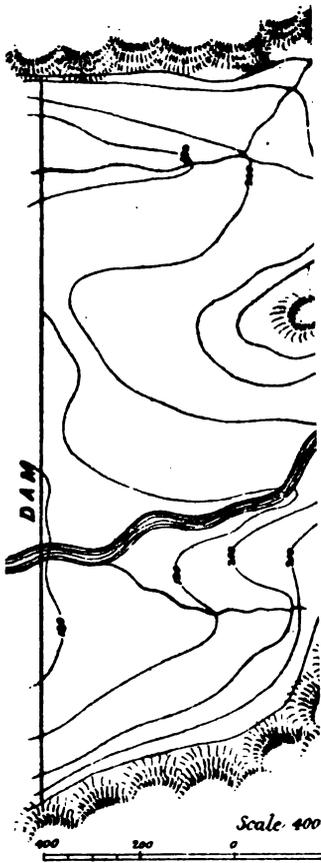

851

prefer-
 ile, or
 should
 id pipe
 s from
 fla, we
 wever,
 il than

igh it
 nity of
 Bom-
 ch the
 water
 Some
 e pro-
 prefer-

Bom-
 reser-
 pe—of
 service
 n rais-

aman to
 informa-
 d except
 aman to
 last por-
 portion
 conduit
 d Tansa

level at
 but this
 s of the
 um.

(which
 ngineers
 Vehar a
 be wise.

referen
from v
would
fortnig
one, w
drawn

Fron
course
follow
is show

Sup;
Kamun
advant
Kamun
the co
wherea
munica
sides t
wherea

If th
siderin
could t
island,
about 4
great e
could r
conduit
of 5 ft
about
of dist:
be bes
a cond
have p:
from 2

* 71
not above
also the g

would be more expensive than a pipe. If then, we say, a pipe, is preferable, the slope to be given to it should be as before—5 feet per mile, or 20 feet for the four miles, and for the $5\frac{1}{2}$ miles of conduit we should require a slope of $5\frac{1}{2}$ feet. So that the total fall of the conduit and pipe from Koorla to Bombay would be $25\frac{1}{2}$ feet, and if we deduct this from the level, $118\frac{1}{2}$ on datum, at which the water would arrive at Koorla, we find that it would reach Bombay at 93 on datum.* I prefer, however, to say 90, because the ground lies better for a conduit at this level than for one a little higher.

Having now got our water into Bombay, the question is, how high it should be pumped. On this point I fear there will be some diversity of opinion. I have hitherto assumed that the average level at which Bombay stands for water-supply purposes—i. e., the average level at which the water is drawn for use—is at about 100 on datum.† I think the water should be pumped somewhat more than 100 feet, or say 125 feet. Some may think the former height sufficient, and I should not oppose the proposition, but I suggest the latter as probably the one that will be preferred.‡

The cost, then, of the Kamun Scheme, if the water were raised in Bombay, would be chiefly made up by the following items—the cost of the reservoir and land at Kamun—of $24\frac{1}{2}$ miles of conduit—of $4\frac{1}{2}$ miles of pipe—of engines, pumps, and engine and boiler-houses in the town—of a service reservoir for use in cases of emergency—and of the fuel consumed in raising the water. This last item must be capitalised.

* No special survey has been made for this low level line of conduit and pipe from Kamun to Bombay, because it would have been mere waste of money to do so, while we had so much information already to enable us to decide on the merits of the scheme. In fact, no survey is required except for the portion between Ewoor and Koorla. The first portion of the line—i. e., from Kamun to Ewoor—has been surveyed, and is precisely the same as that given in *Plate LVII.*, and the last portion—i. e., from Koorla to Bombay—is given in *Plate XL.* It is only the intermediate portion for which a survey could be required. But any one will see that if we can have a high level conduit between Ewoor and Koorla—and I have shown we can in my description of the Ewoor and Tansa projects, and by *Plates XLIII.* and *LIV.*—we can of course have a low level one.

† This must not be confounded with the mean between the greatest height and the lowest level at which the water is drawn in Bombay. Of course some water is drawn at even 180 on datum, but this amounts to a very small quantity. Nine-tenths of the supply is drawn on the ground-floors of the houses and into wells, and these draw-off points are at very low levels—85, 90, and 95 on datum.

‡ When I first brought forward the idea of a low level reservoir with pumping in Bombay (which was in 1869, while the Commission on the Water-supply and Drainage was sitting), several Engineers in the Town seemed to think that 100 feet pressure in the mains, while we now had from Vechar a theoretical pressure of 160 feet, and an actual one of 140, as proved by experiment, would not be wise. I have, therefore, thought it best to suggest a pressure somewhat greater than this.

Now let us consider what would be the effect if the water were pumped up at Kamun. The great advantage would be that it would never have to be raised so high as in Bombay. In the latter case the water would, as the reader has been informed, leave the lake at 140, and arrive in the town at 90 on datum. But the water in the lake itself would be higher than at 140, for, with even a one-year's supply, the surface of the Kamun Lake would stand at 155, with a two-years' supply at 166, and with a three-years' at 175. It would be most advantageous to store at once a three-years' supply, because the additional cost of the dams is not great. Suppose we did impound a three-years' supply at Kamun, then the water which would be used every year would lie between, say, 175 and 170. As a rule, therefore, we should not have to pump any water from below this point. We have proposed that, if the water were raised in Bombay, it should be about 125 feet, or up to 215 on datum. Now, if the water were pumped at Kamun, it is quite clear that it should be distributed to Bombay by a service reservoir at Koorla. The question, therefore, is, in order to effect a comparison between the two schemes, at what level the water should be brought to Koorla. Let me assume that the water is thrown either into the Upper or the Lower Koorla Reservoir. The great advantage of the former would be, of course, that we should command Vihar and be able to fill that lake at any time we wished to do so. The advantage of the latter would be that we should not have to pump the water so high; but it must be remembered, on the other hand, that we should not have so great a pressure in the town by nearly 40 feet.

Supposing, then, we brought the Kamun water to the Upper Koorla Reservoir, and at the same level as the Kennery, Ewoor, and Tansa, water would flow into it, or at 255.50 on datum.* The distance between Kamun and Koorla being $19\frac{1}{2}$ miles, $18\frac{1}{2}$ of this would consist of conduit with a slope of 1 foot per mile—there would be $\frac{1}{2}$ a mile of syphon under the creek, and $\frac{3}{4}$ of a mile of syphon along the depression in the hills, or $1\frac{1}{2}$ mile of pipe with a slope of 5 feet per mile, or altogether of $6\frac{1}{2}$ feet. So that the water in order to reach the Upper Koorla Reservoir at 255.5 on datum,

* There has been no special survey made for this high level line from Kamun to Koorla, but I need hardly say it is perfectly feasible. In fact, there is no survey required except for the portion between Kamun and Ewoor. The line from Ewoor to Koorla would be the same as that for the Ewoor and Tansa Schemes, sections of which are given on *Plates XLIII. and LIV.* As there are high hills all the way between Kamun and Ewoor, of course a high level conduit could be made between these points.

would have to start from Kamun at $(255\frac{1}{2} + 18\frac{1}{2} + 6\frac{1}{2})$, or at) 280 on datum, and would have to be pumped up to this level from 170 on datum. The lift, therefore, would be 110 feet.

If the water were thrown into the Lower Koorla Reservoir, it would have to start from Kamun at 240 on datum, and having to be pumped to this level from 170 on datum, the lift would be 70 feet only.*

The relative cost of the different schemes will be seen presently, when the estimates are given, but I will first notice such other points as call for remark.

The land which would have to be taken up for the Kamun Reservoir would be more expensive than that for any other lake proposed in this report. The valley being exceedingly flat, it is well adapted for cultivation, and much grain and straw are produced and taken elsewhere. Large quantities, also, of firewood are sent into Bombay. In fact, there is a considerable trade carried on by means of barges between Kamun, which is a village of some local importance, and the neighbouring towns. Besides Kamun itself, five other villages would be swamped in the event of a reservoir being formed, and the amount of compensation for all the houses and land and for the loss of trade, would be considerable. Unless the villages were removed, and the occupation of the watershed altogether prevented, objections would be made to the character of the water, but, if these measures were adopted, the water would be perhaps not quite so pure as the present supply from Vehar, but still pure enough for all practical purposes.

Estimate No. 1.

COST OF KAMUN SCHEME FOR A SUPPLY OF $8\frac{1}{2}$ MILLION GALLONS DAILY.

Supply to be pumped by turbines worked by the Ewoor water. Dams at Kamun to impound a one-year's supply from the valley, but equal to 16 gallons per head per diem for three years for the present population:—

	RS.
19 miles of conduit, with a waterway 5 feet wide and 4 deep, between Kamun and Koorla, at Rs. 80,000 a mile,	15,20,000
$\frac{1}{2}$ a mile of syphon pipe under Tannah Creek, 36 inches in diameter, and 1 $\frac{1}{2}$ inch thick, delivering $8\frac{1}{2}$ million gallons daily, and weighing 510 tons, at Rs. 160 a ton, ..	81,600
Carried forward, ..	16,01,600

* No special survey has been made for this low-level line. There is none required, except for the portion between Ewoor and Koorla. The line between Kamun and Ewoor would be the same as that shown in *Plate LVII*. As we can have a high level conduit between Ewoor and Koorla, of course we can have a low level one.

854 THE KAMUN PROJECT FOR "THE WATER-SUPPLY OF BOMBAY."

	RS.
Brought forward,	16,01,600
Tunnel under Creek,	1,50,000
9½ miles of pipe, from Koorla to Bombay, delivering 8¼ million gallons daily, 30 inches in diameter, and 1 inch thick, weighing 790 tons per mile, or 7,505 tons, at Rs. 160 a ton,	12,00,800
Lower Koorla Reservoir,* with its outlet works and waste weir,	5,00,000
No. 1 Dam, Kamun Reservoir (100 feet high, but capable of being raised to the height of 120 feet), containing 5,719,000 cubic feet of rubble masonry, at Rs. 25 per 100 cubic feet,	14,29,750
No. 2 Dam, containing 485,200 cubic feet of masonry,† ..	1,21,300
No. 3 Dam, containing 1,154,200 cubic feet of masonry, ..	2,88,540
Kamun Waste Weir,.. .. .	1,50,000
Kamun Outlet Works,	90,000
Ewoor Dams and Outlet Works (a two-years' supply from the Ewoor valley being impounded in the lake), <i>vide</i> page 252 of No. LXXXI, Professional Papers, Second Series,	28,46,000
Ewoor Waste Weir,	1,25,000
1½ miles of conduit from Ewoor Lake to Turbine Pumping Station, at Rs. 80,000 a mile,	1,20,000
Turbines to raise 8¼ million gallons daily, 100 feet high, and all pumping arrangements and buildings,	3,50,000
	<hr/>
	89,72,990
Add 10 per cent. for contingencies—say,	8,97,010
	<hr/>
	98,70,000
Land for Kamun Reservoir, channels and pipes, and compensation for houses and loss of trade,	5,00,000
Land for Ewoor Reservoir,	75,000
	<hr/>
Total,	1,04,45,000

Or, say, 104½ lakhs for 13 gallons per head per diem for the present population.

If the Ewoor Dams were made high enough to impound a three-years supply, the cost for the same quantity of water delivered would be about 9 lakhs more, or 113½ lakhs.

* If a thinner section for the dam be insisted upon than that shown in *Plate XLV.*, there will be a reduction in this item of about Rs. 75,000.

† If thinner sections than those shown in *Plate LVI.* be insisted upon for Nos. 2 and 3 Dams the reduction in the two items would amount to about Rs. 1,00,000.

Estimate No. 2.

FOR A SUPPLY OF 13 MILLION GALLONS DAILY.

Supply to be pumped by turbines as before. Dams at Kamun to impound as before a one-year's supply from the valley :—

	RS.
19 miles of conduit, as before,	15,20,000
¼ a mile of syphon pipe under Tannah Creek, 42 inches in diameter, and 1¼ inch thick, delivering 13 million gallons daily, and weighing 682 tons, at Rs. 160 a ton,	1,09,120
Tunnel under Creek, as before,	1,50,000
9½ miles of pipe, from Koorla to Bombay, 36 inches in diameter, and 1¼ inch thick, delivering 13 million gallons daily, and weighing 1,020 tons per mile, or 9,690 tons, at Rs. 160 a ton,	15,50,400
Lower Koorla Reservoir with its outlet works and waste weir, as before,	5,00,000
No. 1 Dam, Kamun Reservoir, as before,	14,29,750
No. 2 Dam, Kamun Reservoir, as before,	1,21,300
No. 3 Dam, Kamun Reservoir, as before,	2,88,540
Kamun Waste Weir, as before,	1,50,000
Kamun Outlet Works Weir, as before,	90,000
Ewoor Dams and Outlet Works, as before,	28,46,000
Ewoor Waste Weir, as before,	1,25,000
1½ miles of conduit, as before,	1,20,000
Turbines and Pumping arrangements and Buildings to raise 13 million gallons 100 feet high daily,	5,00,000
	<u>95,00,110</u>
Add 10 per cent. for contingencies—say,	9,50,890
	<u>1,04,51,000</u>
Land, as before—viz.,	5,75,000
	<u>1,10,26,000</u>
Total,	

Or, say, 110½ lakhs for 20 gallons per head per diem for the present population.

As before, it must be borne in mind that the Ewoor Dams have been estimated to impound a two-years' supply only, and for a three-years' supply about 9 lakhs must be added to this estimate.

Estimate No. 3.

FOR A SUPPLY OF OVER 17 MILLION GALLONS DAILY.

Supply to be pumped by turbines as before. Dams to impound a one-year's supply from the valley as before:—

	RS.
19 miles of conduit, as before,	15,20,000
½ a mile of syphon pipe under Tannah Creek, 48 inches in diameter, 1½ inch thick, delivering over 17 million gallons daily, and weighing 880 tons, at Rs. 160 a ton, ..	1,40,800
Tunnel under creek, as before,	1,50,000
9½ miles of pipe from Koorla to Bombay, 42 inches in diameter, and 1½ inch thick, delivering over 17 million gallons daily, and weighing 1,360 tons per mile, or 12,958 tons, at Rs. 160 a ton,	20,73,280
Lower Koorla Reservoir, with its Outlet Works and Waste Weir, as before,	5,00,000
No. 1 Dam, Kamun Reservoir, as before,	14,29,750
No. 2 Dam, Kamun Reservoir, as before,	1,21,300
No. 3 Dam, Kamun Reservoir, as before,	2,88,540
Kamun Waste Weir, as before,	1,50,000
Kamun Outlet Works, as before,	90,000
Ewoor Dams and Outlet Works, as before,	28,46,000
Ewoor Waste Weir, as before,	1,25,000
1½ miles of conduit, as before,	1,20,000
Turbines to raise over 17 million gallons daily 100 feet high, and all pumping arrangements and buildings,	6,50,000
	1,02,04,670
Add 10 per cent. for contingencies—say,	10,20,330
	1,12,25,000
Land, as before	5,75,000
	Total, 1,18,00,000

Or, 118 lakhs for 26 gallons per head per diem for the present population.

And if a three-years' supply were stored in Ewoor for pumping purposes, the cost would be about 127 lakhs.

Estimate No. 4.

FOR A SUPPLY OF 8½ MILLION GALLONS DAILY.

Supply to be pumped by steam in Bombay. Dams at Kamun to impound, as before, a one-year's supply from the valley:—

	RS.
24½ miles of conduit, with a waterway 5 feet wide and 4 deep, between Kamun and Bombay, at Rs. 80,000 a mile, ..	19,60,000
½ a mile of syphon pipe under Tannah Creek, 36 inches in diameter, and 1½ inch thick, delivering 8¼ million gallons daily, and weighing 510 tons, at Rs. 160 a ton,	81,600
Tunnel under Creek,	150,000
4 miles of pipe, for the low ground about Koorla and in the island, 36 inches in diameter, and 1½ inch thick, delivering 8¼ million gallons daily, and weighing 1,020 tons per mile, or 4,080 tons, at Rs. 160 a ton,	6,52,800
No. 1 Dam, Kamun Reservoir, as before,	14,29,750
No. 2 Dam, Kamun Reservoir, as before,	1,21,300
No. 3 Dam, Kamun Reservoir, as before,	2,88,540
Kamun Waste Weir, as before,	1,50,000
Kamun Outlet Works, as before,	90,000
Engines of 300 nominal horse-power,* to raise 8¼ million gallons daily 125 feet high, at Rs. 1,800 per horse-power, including erection and everything,	5,40,000
Engine-houses, boiler-houses, coal-sheds, stand pipes, and all arrangements in Bombay,	3,00,000
Service Reservoirs † in Bombay,	5,00,000
	<u>62,63,990</u>
Add 10 per cent. for contingencies—say,	6,26,010
	<u>68,90,000</u>
Land at Kamun, and for conduits and pipes,	5,00,000
Cost of fuel for raising 8¼ million gallons daily, 125 feet high, on the supposition that the average duty ‡ of the engines is 40,000,000 pounds raised a foot high with a bushel 94 pounds of coal, or, say, 4,000 tons of coal yearly, at Rs. 30 a ton, § amounting to Rs. 1,20,000 yearly, and supposing this sum capitalised at 6 per cent.,	20,00,000
Total,	<u>98,90,000</u>

Or, say, 94 lakhs of rupees for 13 gallons per head per diem for the present population.

* The actual horse-power by calculation is only about 220, but we must have some reserve of power for contingencies.

† If these were dispensed with, the engine-power should be increased by about 100 horse-power, but service reservoirs would be preferable for so large a town.

‡ The average duty for a whole year of the engines at the Sewage pumping-station at Crossness has been 75,600,000 foot pounds, but I assume that the coal in Bombay, will not produce more than the above useful effect. I think this is fair, but I am aware that many are of opinion that coal loses fully half its power in India. The average duty of Cornish engines is only 60,000,000 foot pounds, and the half of this would be but 30,000,000 foot pounds.

§ The price of coal varies from year to year, and is exceptionally high at this moment; but I think Rs. 30 a ton fairly represents the average cost.

358 THE KAMUN PROJECT FOR " THE WATER-SUPPLY OF BOMBAY."

If coals were at Rs. 35 a ton, the cost for the same quantity of water raised 125 feet high, would be 97 lakhs.

If the water were raised 100 feet high only, and coals were at Rs. 30 a ton, the cost of the project for 8½ million gallons daily, would be 88 lakhs altogether.

If the water were raised 100 feet high, and coals were at Rs. 35 a ton, the cost for the same quantity would be about 91 lakhs.

Estimate No. 5.

FOR A SUPPLY OF 13 MILLION GALLONS DAILY.

Supply to be pumped by steam in Bombay. Dams at Kamun, as before, to impound a one-year's supply from the valley :—

	RS.
24½ miles of conduit, as before,	19,60,000
¼ a mile of syphon pipe under Creek, 42 inches in diameter, and 1½ inches thick, delivering 13 million gallons daily, and weighing 682 tons, at Rs. 160 a ton,	1,09,120
Tunnel under Creek, as before,	1,50,000
4 miles of pipe, for the low ground about Koorla and in the island, 42 inches in diameter, and 1½ inches thick, delivering 13 million gallons daily, and weighing 1,364 tons per mile, or 5,456 tons, at Rs. 160 a ton,	8,72,960
No. 1 Dam, Kamun Reservoir, as before,	14,29,750
No. 2 Dam, Kamun Reservoir, as before,	1,21,300
No. 3 Dam, Kamun Reservoir, as before,	2,88,540
Kamun Waste Weir, as before,	1,50,000
Kamun Outlet Works, as before,	90,000
Engines of, say, 450 nominal horse-power,* to raise 13 million gallons daily, 125 feet high, at Rs. 1,800 per horse-power, including erection and everything,	8,10,000
Engine-houses, boiler-houses, coal-sheds, stand pipes, and all arrangements in Bombay,	3,50,000
Service Reservoirs in Bombay,	5,00,000
	<hr/>
	68,31,670
Add 10 per cent. for contingencies—say,	6,83,330
	<hr/>
	75,15,000
Land at Kamun, and for conduits and pipes,	5,00,000
Cost of fuel for raising 13 million gallons daily 125 feet high; say, 6,200 tons, at Rs. 30 a ton, or Rs. 1,86,000 yearly, representing, at 6 per cent., a capital of	31,00,000
	<hr/>
Total,	1,11,15,000

* The actual horse-power by calculation comes to about 340, but, as before, we must allow for contingencies.

Or, say, 111½ lakhs of rupees for 20 gallons per head per diem for the present population.

If coals were at Rs. 35 a ton, the cost for the same quantity of water raised 125 feet high, would be 116½ lakhs.

If the water were raised 100 feet high only, and coals were at Rs. 30 per ton, the cost of the project for 13 million gallons would be about 102 lakhs of rupees.

If the water were raised 100 feet high, and coals were at Rs. 35 a ton, the cost for the same supply would be about 107 lakhs.

Estimate No. 6.

FOR A SUPPLY OF 17 MILLION GALLONS DAILY.

Supply to be pumped by steam in Bombay. Dams at Kamun, as before, to impound a one-year's supply :—

	RS.
24½ miles of conduit, as before,	19,60,000
¾ a mile of syphon pipe under Creek, 48 inches in diameter, and 1½ inches thick, delivering over 17 million gallons daily, and weighing 880 tons, at Rs. 160 a ton,	1,40,800
Tunnel under Creek, as before,	1,50,000
4 miles of pipe for the low ground about Koorla and in the island, 48 inches in diameter, and 1½ inches thick, delivering over 17 million gallons daily, and weighing 1,760 tons per mile, or 7,040 tons, at Rs. 160 a ton,	11,26,400
No. 1 Dam, Kamun Reservoir, as before,	14,29,750
No. 2 Dam, Kamun Reservoir, as before,	1,21,800
No. 3 Dam, Kamun Reservoir, as before,	2,88,540
Kamun Waste Weir, as before,	1,50,000
Kamun Outlet Works, as before,	90,000
Engines of, say, 600 nominal horse-power,* to raise 17 million gallons daily, 125 feet high, at Rs. 1,800 per horse-power, including everything,	10,80,000
Engine-houses, boiler-houses, coal-sheds, stand-pipes, &c., and all arrangements in Bombay,	4,00,000
Service Reservoirs in Bombay,	5,00,000
	<u>74,86,790</u>
Add 10 per cent. for contingencies—say,	7,43,210
	<u>81,80,000</u>
Land at Kamun for conduit and pipes, as before,	5,00,000
Cost of fuel for raising 17 million gallons daily, 125 feet high, say, 8,000 tons, at Rs. 30 a ton, or Rs. 2,40,000 yearly, representing, at 6 per cent., a capital of	40,00,000
Total,	<u>1,26,80,000</u>

* The actual horse-power by calculation comes to about 450.

Or, say, 127 lakhs for 26 gallons per head per diem for the present population.

If coals were at Rs. 35 a ton, the cost for the same supply, raised 125 feet high, would be about 133½ lakhs.

If the water were raised 100 feet high only, and coals were at Rs. 30 per ton, the cost of the project for 17 million gallons would be about 116½ lakhs.

If the water were raised 100 feet high, and coals were at Rs. 35 a ton, the cost for the same supply would be about 122 lakhs.

Estimate No. 7.

FOR A SUPPLY OF 8¼ MILLION GALLONS DAILY.

Supply to be pumped by steam at Kamun, and to flow into the Lower Koorla Reservoir. Dams to impound a three-years' supply from the valley:—

	RS.
19 miles of conduit, as per Estimate No. I,	15,20,000
¼ a mile of syphon pipe under Creek, ditto,	81,600
Tunnel under Creek, ditto,	1,50,000
9¼ miles of pipe from Koorla, ditto,	12,00,800
Lower Koorla Reservoir, ditto,	5,00,000
No. 1 Dam, Kamun Reservoir (120 feet high), containing 6,500,000 cubic feet of masonry, at Rs. 25 per 100 cubic feet,	16,25,000
No. 2 Dam, containing 750,500 cubic feet,	1,87,625
No. 3 Dam, containing 1,986,400 cubic feet,	4,96,600
Kamun Waste Weir,	1,50,000
Kamun Outlet Works,	1,50,000
Engines of 200 nominal horse-power,* to raise 8¼ million gallons daily, 70 feet high, at Rs. 1,800 per horse-power, ..	3,60,000
Engine-houses, boiler-houses, and all arrangements at Kamun,	2,00,000
	66,21,625
Add 10 per cent. for contingencies—say,	6,62,375
	72,84,000
Land at Kamun, and for conduits and pipes,	5,00,000
Cost of fuel for raising 8¼ million gallons daily, 70 feet high, say 2,160 tons, at Rs. 30 a ton, or Rs. 64,800 yearly, representing, at 6 per cent., a capital of	10,80,000
Total,	88,64,000

* The actual power required by calculation is a little over 120.

Or, say, 88½ lakhs of rupees for 13 gallons per head per diem for the present population.

If coal be taken at Rs. 35 per ton, the cost for the same quantity of water would be about 90 lakhs.

Estimate No. 8.

FOR A SUPPLY OF 13 MILLION GALLONS DAILY.

Supply to be pumped at Kamun, and to flow into the Lower Koorla Reservoir. Dams to impound a three-years' supply from the valley :—

	RS.
19 miles of conduit, as per Estimate No. 2,	15,20,000
¼ a mile of syphon pipe under Creek, ditto,	1,09,120
Tunnel under Creek, ditto,	1,50,000
9½ miles of pipe from Koorla, ditto,	15,50,400
Lower Koorla Reservoir, as before,	5,00,000
No. 1 Dam, Kamun Reservoir (120 feet high), as before, ..	16,25,000
No. 2 Dam, Kamun Reservoir (120 feet high), as before, ..	1,87,625
No. 3 Dam, Kamun Reservoir (120 feet high), as before, ..	4,96,600
Kamun Waste Weir,	1,50,000
Kamun Outlet Works,	1,50,000
Engines of, say, 260 nominal horse-power,* to raise 13 million gallons, 70 feet high, at Rs. 1,800 per horse-power, ..	4,68,000
Engine-houses, boiler-houses, and all arrangements at Kamun,	2,00,000
	71,06,745
Add 10 per cent. for contingencies—say,	7,10,255
	78,17,000
Land at Kamun, and for conduits and pipes,	5,00,000
Cost of fuel for raising 13 million gallons daily, 70 feet high, say 3,400 tons, at Rs. 30 per ton, or Rs. 1,02,000 yearly, representing, at 6 per cent., a capital of	17,00,000
	Total, 1,00,17,000

Or, say, 100½ lakhs of rupees for 20 gallons per head per diem for the present population.

If coal be taken at Rs. 35 per ton, the cost for the same quantity of water would be about 102 lakhs.

* The actual horse-power is by calculation about 190.

Estimate No. 9.

FOR A SUPPLY OF 17 MILLION GALLONS DAILY.

Supply to be pumped by steam at Kamun, and to flow into the L Koorla Reservoir. Dams to impound a three-years' supply from valley:—

	RS.
19 miles of conduit, as per Estimate No. 3,	15,20,000
$\frac{1}{4}$ a mile of syphon pipe under Creek, as per Estimate No. 3,	1,40,800
Tunnel under Creek, as per Estimate No. 3,	1,50,000
9 $\frac{1}{2}$ miles of pipe from Koorla, as per Estimate No. 3,	20,73,280
Lower Koorla Reservoir, as before,	5,00,000
No. 1 Dam, Kamun Reservoir (120 feet high), as before,	16,25,000
No. 2 Dam, Kamun Reservoir, as before,	1,87,625
No. 3 Dam, Kamun Reservoir, as before,	4,06,600
Kamun Waste Weir,	1,50,000
Kamun Outlet Works,	1,50,000
Engines of 350 nominal horse-power,* to raise 17 million gallons daily, 70 feet high, at Rs. 1,800 per horse-power,	6,30,000
Engine-houses, boiler-houses, and all arrangements at Kamun,	2,00,000
	<hr/>
	78,23,305
Add 10 per cent. for contingencies—say,	7,82,695
	<hr/>
	86,06,000
Land at Kamun, and for conduits and pipes,	5,00,000
Cost of fuel for raising 17 million gallons daily, 70 feet high, say 4,500 tons, at Rs. 30 a ton, or Rs. 1,35,000 yearly, representing, at 6 per cent., a capital of	22,50,000
	<hr/>
Total, ..	1,13,56,000

Or, say, 113 $\frac{1}{2}$ lakhs for 26 gallons per head per diem for the pre population.

If coal be taken at Rs. 35 per ton, the cost for the same quantity of water would be about 117 $\frac{1}{2}$ lakhs.

*Estimate No. 10.*FOR SUPPLY OF 8 $\frac{1}{2}$ MILLION GALLONS DAILY.

Supply to be pumped by steam at Kamun, and to flow into the U₁

* The actual horse-power required by calculation is about 260.

Koorla Reservoir. Dams to impound a three-years' supply from the valley:—

	RS.
18½ miles of conduit, at Rs. 80,000 a mile,	14,60,000
1¼ mile of syphon pipe (under Creek and along depression in the hills), 36 inches in diameter, and 1½ inch thick, delivering 8½ million gallons daily, and weighing 1,020 tons per mile, or 1,275 tons, at Rs. 160 a ton,	2,04,000
Tunnel under Creek, as before,	1,50,000
9½ miles of pipe, from Koorla to Bombay, 28 inches in diameter, and 1 inch thick, delivering 8½ million gallons daily, and weighing 720 tons per mile, or 6,840 tons, at Rs. 160 a ton,.. .. .	10,94,400
Upper Koorla Reservoir, as before,	8,00,000
No. 1 Dam, Kamun Reservoir (120 feet high), as before, ..	16,25,000
No. 2 Dam, Kamun Reservoir (120 feet high), as before, ..	1,87,625
No. 3 Dam, Kamun Reservoir (120 feet high), as before, ..	4,96,600
Kamun Waste Weir, as before,	1,50,000
Kamun Outlet Works, as before,	1,50,000
Engines of, say 260 horse-power,* nominal, to raise 8½ million gallons, 110 feet high, at Rs. 1,800 per horse-power,	4,68,000
Engine-houses, boiler-houses, and all arrangements at Kamun,	2,00,000
	<hr/>
	64,85,625
Add 10 per cent. for contingencies—say,	6,48,375
	<hr/>
	71,34,000
Land at Kamun, and for conduits and pipes,	5,00,000
Cost of fuel for raising 8½ million gallons daily, 110 feet high, say 3,400 tons, at Rs. 30 a ton, or Rs. 1,02,000 yearly, representing, at 6 per cent., a capital of	17,00,000
	<hr/>
Total,	98,34,000

Or, say, 93½ lakhs of rupees for 13 gallons per head per diem for the present population.

If coal be taken at Rs. 35 per ton, the cost for the same quantity of water daily would be about 96½ lakhs.

Estimate No. 11.

FOR A SUPPLY OF 13 MILLION GALLONS DAILY.

Supply to be pumped by steam at Kamun, and to flow into the Upper

* The actual horse-power by calculation is a little over 190.

364 THE KAMUN PROJECT FOR "THE WATER-SUPPLY OF BOMBAY."

Koorla Reservoir. Dams to impound a three-years' supply from the valley :—

	RS.
18½ miles of conduit, as per previous Estimate,	14,60,000
1½ miles of syphon pipe (under Creek and along depression in hills), 42 inches in diameter, and 1½ inch thick, delivering 13 million gallons daily, and weighing 1,364 tons per mile, or 1,705 tons, at Rs. 160 a ton,	2,72,500
Tunnel under Creek, as before,	1,50,000
9½ miles of pipe from Koorla to Bombay, 33 inches in diameter, and 1½ inch thick, delivering 13 million gallons daily, and weighing 924 tons per mile, or 8,778 tons, at Rs. 160 a ton,	14,04,480
Upper Koorla Reservoir, as before,	3,00,000
No. 1 Dam, Kamun Reservoir, as before,	16,25,000
No. 2 Dam, Kamun Reservoir, as before,	1,87,625
No. 3 Dam, Kamun Reservoir, as before,	4,96,600
Kamun Waste Weir, as before,	1,50,000
Kamun Outlet Works, as before,	1,50,000
Engines of, say, 400 nominal horse-power,* to raise 13 million gallons, 110 feet high, at Rs. 1,800 per horse-power,	7,20,000
Engine-houses, boiler-houses, and all arrangements at Kamun,	2,00,000
	71,16,505
Add 10 per cent. for contingencies—say,	7,11,495
Land at Kamun, and for conduits and pipes,	78,27,000
Cost of fuel for raising 13 million gallons daily, 110 feet high, say, 5,400 tons, at Rs. 30 a ton, or Rs. 1,62,000 yearly, representing, at 6 per cent., a capital of	27,00,000
	Total, 1,10,28,000

Or, say, 110½ lakhs for 20 gallons per head per diem for the present population.

If coal be taken at Rs. 35 per ton, the cost for the same quantity of water would be nearly 115 lakhs.

Estimate No. 12.

FOR A SUPPLY OF 17 MILLION GALLONS DAILY.

Supply to be pumped by steam at Kamun, and to flow into the

* The calculated power is 200.

Upper Koorla Reservoir. Dams to impound a three-years' supply from the valley :—

	RS.
18½ miles of conduit, as per previous Estimate,	14,60,000
1¼ mile of syphon pipe (under Creek and along depression in hills), 48 inches in diameter, and 1¼ inch thick, delivering 17 million gallons daily, and weighing 1,760 tons per mile, or 2,200 tons, at Rs. 160 a ton,	8,52,000
Tunnel under Creek, as before,	1,50,000
9½ miles of pipe, from Koorla to Bombay, 39 inches in diameter, and 1¼ inch thick, delivering over 17 million gallons daily, and weighing 1,260 tons per mile, or 11,970 tons, at Rs. 160 a ton,	19,15,200
Upper Koorla Reservoir, as before,	3,00,000
No. 1 Dam, Kamun Reservoir, as before,	16,25,000
No. 2 Dam, Kamun Reservoir, as before,	1,87,625
No. 3 Dam, Kamun Reservoir, as before,	4,96,600
Kamun Waste Weir, as before,	1,50,000
Kamun Outlet Works, as before,	1,50,000
Engines of, say, 500 nominal horse-power,* to raise 17 million gallons 110 feet high, at Rs. 1,800 per horse-power,	9,00,000
Engine-houses, boiler-houses, and all arrangements at Kamun,	2,00,000
	<u>78,86,425</u>
Add 10 per cent. for contingencies—say,	7,88,575
	<u>86,75,000</u>
Land at Kamun, and for conduits and pipes,	5,00,000
Cost of fuel for raising 17 million gallons daily, 110 feet high, say 7,100 tons, at Rs. 30 a ton, or Rs. 2,13,000 yearly, representing a capital of	36,50,000
	<u>1,28,25,000</u>
Total,	1,28,25,000

Or, 128½ lakhs for 26 gallons per head per diem for the present population.

If coal be taken at Rs. 35 per ton, the cost for the same quantity of water would be about 134 lakhs.

H. T.

* The horse-power required by calculation is over 300.

No. XCII.

SUMMARY OF PROJECTS FOR "THE WATER-SUPPLY
OF BOMBAY."

BY MAJOR HECTOR TULLOCH, R.E.

I HAVE now given such an account of what has already been written and done with regard to the water-supply of Bombay as will enable the reader to understand the position in which the question at present stands. I have given such a description of the surrounding country as should enable him to form an opinion on the facilities for storing water which the different valleys afford, and on the means which would probably have to be resorted to, in order to bring it to Bombay. I have, I trust, demonstrated the superiority of masonry over earthen dams, of conduits over iron pipes, and shown the desirability of making an experiment on the feasibility of rock syphons, and of keeping our pipes above ground. And lastly I have shown, with as much exactness as the question admits of, the capabilities for supply of those particular valleys which, after careful investigation, seem the most promising for our purposes, and I have furnished estimates of the probable cost which will have to be incurred to make the supply from any one of these valleys available for the town.

It is now necessary to summarize the results arrived at, in order that the reader may the more easily make a comparison between the different projects submitted to his judgment.

The quantity of water obtainable from the Kennery valley is about 13 gallons per head per diem, for the present population. To store a one-year's supply will require a dam 130 feet high—a two-years' supply, one of 155 feet—and a three-years' supply, one of 172 feet. And the cost

of the project will be, in the first case, $40\frac{1}{4}$ —in the second, $47\frac{3}{4}$ —and in the third, about 54 lakhs.

Toolsee offers us no more than $5\frac{1}{2}$ gallons per head per diem, for the present population, with dams 77, 92, and 105 feet high, for a one, two and three-years' supply, respectively, and the cost in the first case would be $21\frac{1}{4}$, in the second 25, and in the third 28 lakhs.

Ewoor could supply 10 gallons per head per diem, with dams 124, 141, and 155 feet high. The cost of this supply would be $56\frac{1}{4}$ lakhs with the first dam, 64 lakhs with the second, and $73\frac{3}{4}$ lakhs with the third.

From Tansa could be obtained 140 gallons per head per diem, for the present population, but to store this quantity at first would be absurd. A dam 95 feet high would impound nearly as much water as we now have in the Vehar Lake, and the cost of supplying 13, 20, and 26 gallons per head daily would be 87, $99\frac{1}{4}$, and $115\frac{1}{2}$ lakhs, respectively.

The quantity of water which might be got from the low level reservoir, Kamun, is 48 gallons per head daily, but in this case, also, it would be absurd at first to deliver such a supply to the town. The Kamun water could be made available by various means. If pumped by the water in the Ewoor Lake, the cost of 13, 20, and 26 gallons per head daily would be $104\frac{1}{2}$, $110\frac{1}{2}$, and 118 lakhs, respectively. But if the Kamun supply were pumped in Bombay 125 feet high, with coals at Rs. 30 per ton, the cost for the different quantities above would be 94, $111\frac{1}{4}$, and 127 lakhs, respectively; but with coals at Rs. 35 per ton, the cost would be 97, $116\frac{1}{2}$, and $133\frac{1}{2}$ lakhs. If pumped 100 feet high, with coal at Rs. 30 a ton, the cost would be 88, 102, and $116\frac{1}{2}$ lakhs; but with coal at Rs. 35 a ton, the cost would be 91, 107, and 122 lakhs.

Again, if the water were pumped at Kamun, with coal at Rs. 30 a ton, and delivered to Bombay from the Lower Koorla Reservoir, the cost would be $88\frac{3}{4}$, $100\frac{1}{4}$, and $113\frac{1}{2}$ lakhs; but with coals at Rs. 35, the cost would be 90, 102, and $117\frac{1}{4}$ lakhs for 13, 20, and 26 gallons per head daily.

Lastly, if the water were pumped at Kamun and delivered to Bombay from the Upper Koorla Reservoir, the cost, with coal at Rs. 30 per ton, would be $93\frac{1}{2}$, $110\frac{1}{4}$ and $128\frac{1}{4}$ lakhs, but with coal at Rs. 35 a ton, $96\frac{1}{2}$, 115, and 134 lakhs.

The accompanying table shows, at one view, the cost of all the different projects.

I think it must be manifest to every one who gives but a few minutes' consideration to the subject, that it would be a mistake for the Bench to carry out a scheme with a dam to be raised no higher than sufficient to impound a one-year's supply from any of the smaller valleys. The failure of a single monsoon would, in such a case, cause the supply to the town to be suspended. A two-years' supply seems to me to be the very least which should be impounded. In such a case two successive failures of the monsoon must occur before the water could be consumed, and I think there are objections to a scheme with a reservoir of even such capacity. In considering the different projects, this point should have its weight. We will take the projects in the order exhibited in the table.

The Toolsee Valley not being capable of giving us more than $3\frac{1}{2}$ million gallons yearly, we cannot look to it as a permanent source for increasing the supply of the town. If any one of the Toolsee Projects is carried out, it will hardly give sufficient relief to the town even at present, and we shall be compelled to adopt some other scheme in addition. We may, therefore, assume that, however desirable the Toolsee Scheme may be in itself, it cannot be considered as a solution of the water-supply question.

Let us analyze the Ewoor Project. To impound only a one-year's supply being absurd, it would cost us, with a dam impounding a two-years' supply, 64 lakhs to obtain $6\frac{1}{2}$ million gallons daily from this valley. There are four objections to the adoption of this scheme. It is incapable of extension. Its cost, in proportion to the quantity of water supplied, would be very great. The main dam would require to be built at once 141 feet high. And, in the event of two failures of the monsoon, no water would be obtained from it. On these considerations, and remembering that by the expenditure of a few more lakhs, we might secure far greater advantages than Ewoor offers, I am of opinion that the Bench would not be acting wisely to sanction any one of the Ewoor Projects.

The supply from Kennery, would be cheaper than that from any other valley, excepting Toolsee. On the other hand, the fact must be looked at in the face, that the Dam cannot be less than 155 feet high. It must also be remembered that the supply from Kennery is not capable of extension, and it is quite clear, therefore, that, if the Kennery Scheme be carried out, it must be supplemented by some other project after 10 or 15 years. It cannot be compared with either the Kamun or Tansa Schemes, because these afford us a supply which can be increased from

TABLE SHOWING VARIOUS QUANTITIES OF WATER FROM

Name of Valley.		KAMUN.								
		Applying 11,000,000,000 gallons yearly, or 31 million gallons daily, or 48 gallons per head per diem for the present population.								
		Dam to be 100 feet high, impounding 7,000,000,000 gallons.				Dam to be built at once, 120 ft. high, impounding as above 11,000,000,000 gallons.				
Number of Gallons per head per diem for the present population.	Number of million gallons daily.	Day 77 4 high, pound on year sapp	Supply pumped in Bombay.				Supply pumped into Lower Koorla Reservoir.		Supply pumped into Upper Koorla Reservoir.	
			100 ft. high.		125 ft. high.		Coals Rs. 30 a ton.	Coals Rs. 35 a ton.	Coals Rs. 30 a ton.	Coals Rs. 35 a ton.
			Coals Rs. 30 a ton.	Coals Rs. 35 a ton.	Coals Rs. 30 a ton.	Coals Rs. 35 a ton.	Coals Rs. 30 a ton.	Coals Rs. 35 a ton.	Coals Rs. 30 a ton.	Coals Rs. 35 a ton.
5½	3½	Lakt 21								
10	6½									
13	8½		Lakhs. 88	Lakhs. 91	Lakhs. 94	Lakhs. 97	Lakhs. 88½	Lakhs. 90	Lakhs. 93½	Lakhs. 96½
20	13		Lakhs. 102	Lakhs. 107	Lakhs. 111½	Lakhs. 116½	Lakhs. 100½	Lakhs. 102	Lakhs. 110½	Lakhs. 115
26	17		Lakhs. 116½	Lakhs. 122	Lakhs. 127	Lakhs. 133½	Lakhs. 113½	Lakhs. 117½	Lakhs. 128½	Lakhs. 134

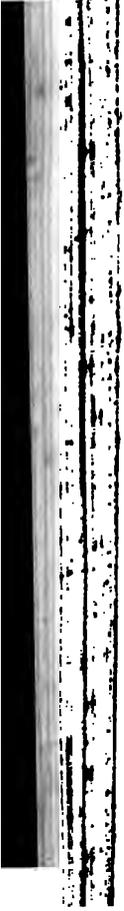

time to time as the demands of the town become greater, whereas the supply from Kennery is only sufficient for the immediate requirements of the population.

The Tansa Project is the cheapest one admitting of extension.

The Kamun presents many aspects, but the idea of pumping the supply with turbines worked by help of the Ewoor water must be abandoned. The estimates show that the Ewoor Dams would be far too expensive for a project of this nature to be entertained. Nor do I think that it would be wise to erect the pumping engines at Kamun. It might be a little more expensive to pump up the water in Bombay, but then the great advantage of having the engines under the immediate care of the Bench and its officers would compensate for this. All kinds of irregularities might go on at Kamun without detection, but it would be the fault of the Justices themselves if irregularities were practiced in the town. Under these circumstances I cannot recommend that form of the Kamun Scheme in which the water would be raised far away from Bombay.

For a large supply, the issue is now confined to the merits of two projects—the Tansa, with its high level service reservoir at Koorla, and the Kamun, with its pumping works in Bombay. Both offer us much more water than we can possibly require at present. The Tansa would practically give us a somewhat greater pressure than we have in the Vehar mains. The pressure, if the water were pumped in Bombay, could be as great as the Bench chose to make it, but, to be the same as that obtained by the Tansa Project, the water would have to be raised from 125 to 150 feet high. Let us assume that the height of 125 feet would be sufficient, and that the same quantity of water were supplied from each valley. I am of opinion that for a large supply, the Bench would do wisely to arrange for one of not less than 13 million gallons daily. The cost of this quantity from Tansa would be about 100 lakhs, from Kamun about 112 lakhs. If the water were pumped 100 feet high instead of 125 feet, the Kamun Project would cost about two lakhs only more than the Tansa. During this year, coals have risen considerably in price, and the general idea seems to be that the rise will be a permanent one, and is due, not so much to excessive demand as to the rise in the price of labor, and to the reduction in the number of working hours which has taken place all over England. At all events, the price of coal is an uncertain element in the estimate of the Kamun Project, and while I think Rs. 30 a ton will proba-

bly be a fair average to allow for some years to come, I am aware that many will contend this is too small an allowance. If coal continues to rise in price, of course the cost of raising the Kamun water in Bombay will be above what it has been put at. We will, however, assume that 13 million gallons daily from Kamun will cost about 10 lakhs more than the same quantity from Tansa.*

Another very uncertain element of the Kamun Project is the duty which may be expected from a bushel of coal. On this question also there is sure to be much diversity of opinion. The Crossness sewage pumping engines in London have done throughout the year an average duty of 75,000,000 foot pounds, and the average duty of Cornish engines[†] is 60,000,000 foot pounds. I have assumed for the Bombay engines an average duty per bushel of 40,000,000 foot pounds, but I am aware that many are of opinion that coal in India does not produce a useful effect of more than half the amount it does in England. According to these Engineers, therefore, I should not be entitled to take more than, say, 35,000,000 foot pounds as the average duty to be expected from the use of coal in Bombay. If this be the case, the cost of coal will be increased by more than 12 per cent., and this will add several lakhs to the total of the estimate.

The height of the Kamun Dam at first would be 100 feet, and ultimately 120 feet; that of the Tansa Dam at first would be 95 feet, and ultimately 130 feet. It is not absolutely imperative that the Kamun and Tansa Dams should be of these heights, but I think the advantages which would be secured by building them as proposed are so great that it would not be advisable to have lower ones. In the case of Kamun, if the dam were made lower, the water would have to be drawn off from a lower point,—it would reach Bombay at a lower level, and the lift, therefore, for the pumps would be a greater one. The uncertainty of the cost of coal, and the general principle upon which Engineers proceed—viz., that first cost[‡] is not nearly so important an item to effect a saving in as a constant yearly charge—induces me to recommend that the dam should be built ten or twenty feet higher—rather than that the water should be pumped this extra height. The difference then between the dams would be this: the

* Since writing the above, I find coals have risen considerably in price, and it is currently reported that in the ensuing winter, they will be as high as 42s. per ton in London.

† A first cost is known, but a yearly charge like that for coal is liable to increase from year to year, and to attain enormous proportions in the future.

Tansa Dam would be at first five feet lower, but ultimately ten feet higher, than the main Kamun Dam. This would be somewhat to the advantage of Kamun if the sites were equally favorable, but it is in this respect that the Kamun Project is so inferior. The reader is aware that the bed of the stream at Kamun is at 80 feet on datum, or just at about mean sea level. The water at high tide, therefore, would be washing over the face of the dam wall. This I consider a very trifling objection, inasmuch as it would be easy to protect the wall from injury; but what is really a point worth great consideration is the depth to which we should have to carry the foundations. Several pits were dug along the line of the dam, and to the depth of from 15 to 20 feet. In every case the soil proved to be a mixture of clay and sand, through which the water came pouring in in such large quantities, that it could not be kept down by baling. Moreover, in some of the pits, although we dug as low as 20 feet below the surface, we did not come on rock. These facts prove that, in building the dam, it would be absolutely necessary to keep the water out down to a depth of 20 feet below mean sea level, and probably to a greater depth than this; nor could we positively reckon on obtaining a perfectly sound foundation for a dam even at these low depths. In my estimates I have made no special allowance either for pumping or for building in the foundations, but have supposed that these charges would be covered by the item of contingencies at 10 per cent. Now in the case of the Tansa Dam nothing could be more favorable than the bed of the stream. It is as smooth as a pavement, and the rock lies bare, so that its texture can be seen to perfection. If further evidence of the soundness of the rock be required, it is only necessary to trace the river for a mile either above or below the site of the dam. Everywhere it runs over the same kind of rock, hard and smooth—similar in its qualities to the best trap used for building purposes in Bombay.

Not only is the foundation for the dam better at Tansa than at Kamun, but the section across the valley is so much more favorable. The high portion of the Tansa Dam would be very short as compared with the high portion of the Kamun Dam. I pointed out previously how important, in judging of dams, this point was, and, if the reader will refer to the Plates of the several dams, he will find that, excepting the site for the Toolsee Dam, that for the Tansa is the most favorable of all. The hills rise at once from the banks of the river to 90 feet on one side

and 70 on the coast, and the high portion of the dam subsequently is confined to the narrow gorge through which the river has its way for itself. Now the Kamun river flows, not through a narrow gorge between hills, but across a plain about 500 yards wide, and the ground, instead of rising at once from the banks of the stream, lies not far except from the extremities of the plain, *vide* *Figure XVI.*

Considering, therefore, the length to which we should have to extend at Kamun to reach solid rock, the uncertain nature of the strata at the bottom, the difficulty and expense of keeping the foundations clear of water during construction, and the great length of the high portion of the dam, I am of opinion that a dam 150 feet high on such a site as we have got in the Tansa valley, would be built with greater safety, and would afterwards be more secure than one 120 feet high at Kamun. But when we remember that the actual difference in heights between the two dams cannot exceed 10 feet, and may not even be so much, because the excavations at Kamun may have to be carried to a greater depth than we have supposed, the advantages of the Tansa Dam are evident.

The quality of the water from the two valleys would not differ much; perhaps that from the Tansa might be a little purer, as there is more rock in that district.

The means employed to bring the water to Bombay would be the same. Conduits and iron pipes would have to be employed. The Tannah Creek would have to be crossed in both cases, but the stream is twice as wide at Kilsat as at the crossing point for the Kamun Channel. In the former case, however, the depth of the water is 25 feet, and in the latter as much as 100.

Considering, then, that with coals at Rs. 30 a ton, and with the pumping engines doing an average duty of 40,000,000 foot pounds for every bushel of fuel expended, the Kamun Scheme would still cost 12 lakhs of rupees more than the Tansa—considering that coals are steadily rising in price, and are higher at this moment than they have ever before been, and that, if they continue to rise, the allowance of Rs. 30 a ton will not be sufficient to cover their cost—considering that the duty of the engines may also turn out to be less than that assumed in framing the estimates—considering the difficulties that must be encountered in building the Kamun Dam, and the uncertain nature of the strata on which the work must stand, and, considering, on the other hand, the remarkably favor-

able, indeed unexceptionable, foundation which is to be obtained for the Tansa Dam—considering how great is the length of the high portion of the Kamun Dam, and how short that of the Tansa one—considering, too, that by the help of the Tansa Project we can improve the existing water works, by keeping the Vehar Lake always full, and that this advantage cannot be secured by the Kamun Scheme if the water is pumped in Bombay,—I cannot hesitate to recommend the Tansa Scheme as the one most worthy of adoption by the Bombay people for a large supply of water.*

With regard to the Toolsee Project, if matters have not already proceeded too far to allow of the form of the dam being altered, I entreat that the height of this work be fixed at 105 feet. By making the dam 80 feet high only, as I understand is proposed, the Bench are foregoing their power to store water for future contingencies. No more water can be stored in Vehar, except at an enormous expense; none in Ewoor except also at a great outlay. The only two valleys where, speaking financially, it is practicable to keep a supply for contingencies, are Kennery and Toolsee. And in Kennery this can only be done by the help of a very high dam, against which objections are sure to be raised. In fact, the Toolsee is the only valley in Salsette where we may keep a good stock of water, without incurring much expense, and with a dam of ordinary height. To the argument which may be brought forward, that the dam on the dividing ridge between the Toolsee and Vehar Lakes may make the latter insecure, my reply is—in the first place, this dam would be no more than about 55 feet high; in the second, its strength, if built according to Mr. Rankine's section, would be about 50 per cent. more

* In recommending the high level Tansa Project as one better worthy the consideration of the Bench than the low level Kamun one, it cannot be urged that I do so because it is more essentially my own proposition. Whatever little credit may attach to the suggestion of a low level project for Bombay, I think I may lay claim to it as having been the first to bring it to the notice of the former Commissioner, Mr. Crawford. In giving my evidence before the Water-supply and Drainage Commission, in 1869, I was severely cross-examined on this subject, and although I felt perfectly certain at the time that a project with a low level reservoir was possible, I was aware that I had failed to convince many people of the practicability of bringing water to Bombay in a low level conduit. The members of the Commission, however, were evidently satisfied on the subject, as their recommendations were to the effect that a scheme of this kind was the best for the town. Little did I think, while giving my evidence, that not only was a low level conduit feasible, but that it was actually possible to have a high level one for the greater portion of the distance to Bombay. Had I mentioned at that time that such an idea had occurred to me, I feel certain I should have been laughed at. It is the fact of the practicability of a high level conduit, made manifest by my recent surveys, which has, in addition to the other reasons stated above, induced me to give the preference to the Tansa over the Kamun Scheme.

than necessary; * in the third, a masonry dam, and especially of an enormous strength, could not by any possibility be carried away bodily and in the fourth place, if the dam could not be carried away bodily, harm could come to the Vehar Lake from its construction.

The projects, then, which in my opinion deserve the special attention the Bench, are the combined Kennery and Toolsee Projects, for a supply 13 gallons per head per diem for the present population, and the Tax Project for a supply of 20.

In the former case, whatever may be the heights to which it may be decided to raise the Kennery and Toolsee Dams now, the sections of these dams should be such as to admit of the former being raised ultimately to the height of 155 feet, and the latter to the height of 105 feet. The reason why I recommend these heights is, that the Toolsee Dam will then be able to impound a three-years' supply from that valley, and the Kennery a three-years' supply from its own valley, and in the two lakes together, it will hereafter be possible to store a three-years' supply from the whole watershed of these valleys taken together. However little water we may choose at present to store for our own purposes, we should be doing our utmost on behalf of future generations by giving them the opportunity, should they think fit, to store, hereafter, a full three-year supply. In fact, while looking to ourselves, we shall not be selfishly sacrificing the interests of those who come after us.

If, then, the Kennery and Toolsee Projects be decided upon, the water should be taken by one channel to the Upper Koorla Reservoir, and delivered to Bombay from that point. Beyond this remark there is no explanation called for on my part, as the description already given of these projects in Article Nos. LXXIX. and LXXX. of Professional Papers, Second Series, is sufficiently explicit for all purposes. The financial aspect of the question only remains to be gone into.

To carry out the Kennery and Toolsee Projects, even if the Bench decide to raise the dams at once to the heights recommended by me, would cost almost exactly sixty lakhs of rupees. Public loans in England are now made repayable in 50 years, and I should think there would be no difficulty in getting the Imperial Government to grant money on the same terms to the town of Bombay. If this be the case, then the sum required by the Bench yearly to pay off 60 lakhs in 50 years, together with the

* Vide paragraph 22, Appendix B. of No. LXVIII., Professional Papers, Second Series.

interest thereon, so that at the end of that period they should have discharged all liabilities against them, would be Rs. 3,80,687½.* I have already shown† that the surplus in hand at the end of each year, out of the receipts from the present waterworks, after paying what is due to the Government and for the maintenance of the works, amounts to Rs. 1,55,000. In order to carry out the Kennery and Toolsee Projects, the Bench would, therefore, require to raise a revenue of (Rs. 3,80,687½ — Rs. 1,55,000 =) Rs. 2,25,687½, and a further sum of about Rs. 35,000 would be required for the maintenance and extension of the works.‡ The total sum to be raised yearly would thus amount to, say, Rs. 2,60,000.

The present works yield Rs. 3,80,000 yearly, and they supply six gallons for every five which the Kennery and Toolsee works would give hereafter.§ Considering that not even half the town of Bombay is properly supplied with water, there can hardly be any doubt of our being able to utilize all that we should obtain by the proposed projects. They should, therefore, yield Rs. 3,16,666. But we do not require more than Rs. 2,60,000. It will thus be seen that there is every prospect of success in the financial part of the undertaking. We should have a balance of about half a lakh of rupees yearly on the safe side.

If the Bench object to the Kennery Project on the ground that the dam must be so very high, then I am of opinion that it would be best to carry out the Tansa Scheme for 13 million gallons daily. The reason why I recommend this supply in preference to one of 8½ million gallons is, that the difference of cost in the two cases is 12½ lakhs only. To supply the latter quantity would cost 87 lakhs, while to supply the former would cost 99½ lakhs; and the sum of money which the Bench would have to raise yearly, in order to pay off the former debt in 50 years, would be about 4½ lakhs of rupees, while that required to expunge the latter would be about 5½ lakhs.|| Now, it seems to me that it would be easier to raise a revenue of 5½ lakhs yearly with a supply of 13 million gallons daily, than it would

* This may be taken as correct, having been calculated from the table prepared by the actuary of the National Debt Office, which is in use by Her Majesty's Government.

† Page 200, in No. LXXVII., Professional Papers, Second Series.

‡ The present establishment, with a very small addition to it, would suffice for the superintendence of all the new water works, and this farther sum would go almost altogether towards the extension of works of distribution in the town.

§ In Article No. LXXIX., Professional Papers, Second Series, I have shown that the Vihar Valley yields 3,600,000,000 gallons yearly, while from the Kennery Valley (including Toolsee) we may expect to obtain 3,000,000,000 gallons only.

|| These sums include about Rs. 35,000 yearly for maintenance and extensions, but I have, as before assumed that Rs. 1,55,000 will be obtained from the Vihar Works.

be to raise one of $4\frac{1}{2}$ lakhs with $8\frac{1}{2}$ million gallons. If we obtained as much proportionately for the 13 million gallons daily as we now obtain from Vehar for, say, 10 million gallons, we should realize about 5 lakhs of rupees per annum,—very nearly as much as we should require. An inappreciable increase in the charge for water would cover the small deficit of Rs. 25,000, and enable the Bench to balance expenditure with income.

If, however, the project of $8\frac{1}{2}$ million gallons daily from Tansa were carried out, the revenue we should obtain would be about Rs. 3,15,000.—or about Rs. 1,10,000 less than we should require. This project, therefore, does not give us the prospect of financial success which the other does.

Being well acquainted, as I am, with the Bombay Water Works, and having bestowed particular attention on the subject, I am most emphatically of opinion that there is great room for improvement in the distribution of the water throughout the town, and that the scale of charges should be revised. I have no hesitation in adding that, if the subject were taken in hand by a Committee, and new regulations enforced, the Bench would realize nearly a lakh of rupees more than they do at present from even the Vehar supply, and that there would be really no financial difficulty in carrying out the Tansa Project for a supply of 13 million gallons daily. The revenue under an improved system would not only be sufficient to defray all charges on the debt, but would give a balance in hand for the still further extension of the Water works, when the time arrived for increasing the supply.

My recommendations, therefore, to the Bench are :—

Either to carry out the Kennery and Toolsee Projects for a supply of $8\frac{1}{2}$ million gallons daily, or to carry out the Tansa Project for a supply of 13 million gallons.

If the former be decided upon, the Toolsee main dam to be built at once—or, at all events, so as to admit of its being raised hereafter—to the height of 105 feet, so that the water may stand at 470 feet on datum, and a three-years' supply from the valley be impounded. And the Kennery Dam to be built at once—or so as to admit of its being raised afterwards—to the height of 155 feet, so that the water may stand at 345 on datum, and a three-years' supply from the lower portion of the valley may be impounded.

That, whatever is done now, "the future as well as the present wants of the city should be borne in mind."*

That future works should be, if possible, extensions of present ones, and not independent of them.

That, in carrying out any high-level project whatsoever, it would be a great mistake not to command the Vehar Lake, so as to be able to keep it full whenever considered desirable.

That, whatever reservoir be adopted, if the heights for the dams proposed by me be not approved, the dams be, at all events, built so as to be capable of being raised in the future to those heights. Thus the prospective supply would not be marred by any steps taken to relieve our own immediate wants.

That the water from every high-level reservoir which may be constructed, be brought by conduit as near to Bombay as possible—*i. e.*, to the Upper Koorla Reservoir, before being delivered under pressure.

That conduits be adopted in preference to pipes wherever they are practicable, whether in open cutting or in tunnelling.

That all future dams be of masonry, and constructed according to the principles laid down by Mr. Rankine.

That an experiment be made regarding the practicability of rock syphons.

That an experiment be made to ascertain to what extent the temperature of the water in a main exposed to the sun would be effected, and, if the temperature be not affected so as to render the water practicable warmer than it would be in a main under ground, that all pipes laid down hereafter for the supply of Bombay be placed on standards above ground.

H. T.

* These are the words of the Commission on the Water-Supply and Drainage, of which Mr. Scoble was President.

No. XCIII.

THE CANAL OF MINIMUM COST.

By A. G. MURRAY, Esq., C.E., *Exec. Engineer, P. W. D.*

PARA. 576, of the "Roorkee Treatise on Civil Engineering" opens an interesting problem, viz. :—

Given data.

Slope of country, 1-2500, or $\cdot 4$ per 1000 feet.

Velocity of stream allowed, 2.5 feet per second.

Discharge of water 5000 feet per second.

Height of tow-path above water, 2 feet.

The question to be solved is, how can this canal be made cheapest

As shown in para. 576, the most economical case is when the bed surface of the country have the same slope.

Referring to Neville and omitting small fractions, we find that when slope is 1-2500, the hydraulic mean depth is 2 feet. V being = 2.5 second. The bottom width of a canal discharging 5000 feet per sec at a velocity of 2.5 feet per second, when the depth is 2 feet is 997

Now this certainly looks very impracticable, and probably many queries have stopped at this point.

We will, however, work the question out.

We will assume the cross section of the canal to be thus—

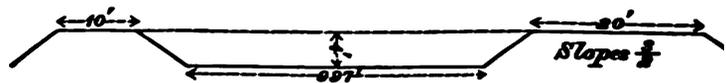

the cutting in the bed required to make up the banks is 0.16.

The area of the bank is 159.42 square feet, area of cutting, 159.42 square feet, which is near enough, practically. Then the earthwork required per

feet run of canal lineal is only cubic feet 797,100, at Rs 3 per 1000 cubic feet = Rs. 2391·3. No falls at all are required.

The bridges for village roads are not absolutely needed, as people and cattle can easily ford a stream only two feet deep. Bridges for main metalled roads would probably not be needed oftener than once in twenty miles, and would generally add Rs. 500 per mile when distributed over the total length.

The formidable item is the land taken up.

Now, it happens that in most of the districts where new canals are proposed, the land is almost a desert, and is worth next to nothing.

The area taken up is acres 126·26 per 5000 feet forward of the canal. In many parts of the Punjab, desert land is not worth Rs. 1 per acre, but suppose that it is worth Rs. 50 per acre.

The cost of land per 5000 feet forward of the canal is then Rs. 6,313. We then have per 5000 feet forward of canal—

	RS.	A.	P.
Land, at Rs. 50 per acre,	6,313	0	0
Earthwork,	2,391	3	0
1-20th share of a bridge,	500	0	0
Total Rupees,	9,204	3	0

When the land is bad, as most of it is, this will be reduced to Rs. 3,000 per 5000 feet run of canal.

Now, considering that there are forty or fifty million acres of desert in the Punjab, taking up a few thousand acres in extra width of canal, is hardly a serious difficulty, when we can make a canal for Rs. 3,000 per canal mile. The objections to this scheme are evaporation and silt banks.

1st. Evaporation.—As the air must be brought to a tolerable state of saturation, say 0·5 full saturation, corresponding to the temperature, it is a matter of indifference whether the evaporation takes place off the canal surface, or off the field, the necessary point of saturation will be reached either way.

The greatest registered evaporation is 8 cubic feet per 1 square foot per annum. In the case of a canal 100 miles long, mean width of water surface 250 feet, supply 5000 cubic feet per second, the loss by evaporation in the year is equal to the flow per hour 55·55, or an annual loss of 0·64 per cent. of the supply.

2nd. Silt.—This and weeds would probably give trouble, but the cost of

clearance would hardly exceed Rs. 100 per mile, annually, if it reached this.

Now, considering that canals of this size to deliver cubic feet 5000 per second, generally cost Rs. 50,000 per mile, there is evidently an opening for economy.

When we get further down the country, the surface slope will become 1-5200, or so, and assuming the same discharge and velocity, the hydraulic mean depth becomes 4 feet.

Bottom width, 494.

Height of tow-path above bed, 7 feet.

Depth of cutting required to balance banks, 0.63 (area 311.81).

Earthwork per 5000 foot run of canal, cubic feet 1,559,050, at Rs. 3 per 1000 cubic feet, Rs. 4,677.

A bridge would be necessary, say once in five miles, add Rs. 1000 per mile to the cost.

But, as in practice, the canal gets narrower as we go down, so shorter, and shorter bridges will be needed; but we will assume the bridges to cost Rs. 500 per mile.

The land down at the low end of the canal is worthless, but we will add Rs. 50 per mile.

We now get, per mile—

	RS.	A.	P.
Earthwork,	4,677	0	0
Bridges,	500	0	0
Land,	50	0	0
Total Rupees, ..	5,227	0	0

Now, as only $\frac{1}{3}$ th of the total length of the canal can be calculated at the higher rate for land, we get an average cost per mile of Rs. 6,022. Now, if any one interested in this problem will refer to the canal Reports of late date, he will see a considerable margin.

Navigation is not specially provided for, flat boats can go in 1.5 feet of water, and if any large traffic arose, it will obviously be cheaper to make a light railway for it than to make a canal 6 feet deep with falls on the usual pattern. If any one can show how to deliver 5000 cubic feet per second at a lower rate per mile, it is to be hoped he will give the public the benefit of his ideas.

If, however, a uniform depth of water of 6 feet is insisted on, falls must then be used. The cheapest way to adopt falls is to use a fall which shall check the *vis viva* of the water, without entailing heavy earthwork.

By taking out the actual quantities, we find that by using 4-foot falls instead of the usual 8-foot fall, we reduce the earthwork to about one half, and as the momentum to be resisted by the floor varies as $8\sqrt{h}$, all the work is much lighter; these 4-foot falls will usually come once in three miles instead of an 8-foot fall once in six miles, and can at a very small additional expense be used as bridges. In the last Sirhind Canal Report, the momentum to be resisted is understated, the water falling over an 8-foot fall will strike the surface of water in the lower basin with a velocity of 25 feet per second, not 6.6 as stated, this is only the velocity on the crest, not the final velocity. It is obviously a great objection to have to resist water falling with so great a velocity.

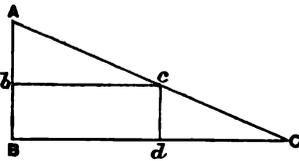

Bisect AB at b , and BC at d , the triangle ABC = twice the area of the two small triangles Abc and cdC .

AB represents an 8-foot fall, Ab and cd two 4-foot falls.

It is extremely doubtful if the cisterns adopted by Colonel Dyas, below falls have an effect in reducing the action of the water. In the Ganges Canal and Bari Doab Canal, we find pools 45 feet deep below the falls, in addition the level of the bed for many miles has been lowered 7 feet by scour, this represents the work done by the force called into action by a series of falls.

The papers written on this subject, appear to treat water as a solid, when a solid falls on a plane at right angles, supposing both to be absolutely hard, the motion is then converted into heat.

But in fluids the pressure acts equally in all directions. A familiar example is the splashing of a rifle bullet on an iron target, though lead is far from being a perfect fluid.

In the same way when water falling strikes water in a lower basin, most of the force is expended in driving the water out of the basin; and, as shown in Col. Dyas' diagram of a fall, this causes the water in the basin to rise up till the head is sufficient to produce a discharge equal to the supply, and as the lower end of the basin is the same area as the canal, an intense scour takes place there, as the bed is not firm enough to stand this velocity. Of course some force is expended in overcoming the friction of the water in the basin, but this being smooth brickwork,

only a small fraction of the force is expended in this way, and most of it is expended in digging holes and scouring out the canal bed.

Probably the best way to use friction to reduce the velocity of the water falling would be to pass it through a series of gratings, about nine inches apart, the lowest grating being a foot below the surface of the water in the lower basin, these would prevent the velocity accumulating above four or five feet per second, and so save the necessity for the very heavy foundations now used, and enable us to dispense with the cistern, a very serious objection to which is that the necessary foundations generally go below the upper clay beds, and expose the silt bed underneath, thus entailing the necessity of well foundations at a very great cost. Thus showing that by using 4 feet falls we can save half the expense of earthwork, reduce the cost of masonry, and have a canal much less likely to fail in the foundations of falls and locks.

There now only remains the dam question—are dams really needed at all?

Their enormous cost is, in many cases, sufficient to forbid the construction of a canal in certain places where stone is not available. General Strachey and the late Colonel Anderson differed on this point. General Strachey, whose report on the Lower Sutlej and Indus was written after Col. Anderson's, believes that it is quite possible to keep a large canal running without any dam at all. The great objection to a dam, putting cost aside, is that it checks the velocity of the stream, and throws down silt, a large portion of this silt goes into the canal. Neither General Strachey nor Col. Anderson investigate the cost of keeping such a canal open by means of a fleet of small dredgers. As shown by both these eminent engineers, all the silt is deposited at the head of the canals, suppose we have to dredge out a channel of the following sizes annually, viz., 3 miles long, 300 feet wide, and 8 feet deep, we have cubic feet 36,000,000, at Rs. 10 per 1000, which is a very high rate, seeing the silt has only to be raised 8 feet, we have an annual cost of Rs. 3,60,000, whereas a dam is put at the minimum of £1,000,000, the interest on this at 7 per cent., is Rs. 7,00,000, or nearly double the cost of dredging out a new channel annually 3 miles long; though we have charged the dredging at an excessively high rate, in fact double the estimate rate on the Sirhind Canal, and where the cutting is 30 feet deep, and dredging is not practicable.

Probably the best style of dredger would be quite a small, cheap affair, of about 10-horse power, drawing 3 feet of water. As soon as the river

began to fall, the fleet of dredgers should commence work, and if properly managed, should be able to excavate as fast as the water fell, and so keep the stream running constantly.

Similar small dredgers are used with success on the Madras Canals. In the case of the Ganges Canal it was necessary to have the head close to the hills, but in the case of the irrigation of the Punjab and Sind deserts, the canal heads may be a hundred miles lower, as there is plenty of desert at a suitable height, and we can then avoid the enormous cost attending canals, when the head is close to the hills.

A. G. M.

No. XCIV.

DISTRIBUTION OF CANAL WATER.

[3RD PAPER. *Vide* Nos. CLXVII. AND CCXI. OF FIRST SERIES].[*Vide* Plate No. LIX.]By E. A. SIBOLD, Esq., *Exec. Engineer, Sirhind Canal.**Rupar, June 28th, 1878.*

In the Punjab, the bulk of the irrigation is on extensive plains, where alignment of Rajbuhas may to a great extent be subordinated to convenience of revenue arrangements, without committing a serious Engineering error. Moreover, there is such a dry atmosphere here, that high level Rajbuhas would not cause malaria, and for economical distribution, the high level Rajbuha is the best. In constructing Rajbuhas, most of the errors have been due to designing them, more as carrying than as distributing channels. In addition to mechanical, there are revenue, difficulties about the employment of meters.

The mechanical difficulties are—

1. Uncertain and usually very small head of water available.
2. Outlet working submerged, and rarely with a clear fall.
3. Silt and drift clogging moving parts, and *altering* dimensions of orifice.

The revenue difficulties are—

1. Cost of construction.
2. Great risk of meter being tampered with by irrigator or his enemies. The cost of protecting a mechanical novelty in an outlying field being more than its worth.
3. The meter gives no data for apportioning supply to demand.

4. Water is so bulky compared to its price in irrigation, that mathematical accuracy is out of place. Rough approximation, (as in collecting tolls on the tonnage of ships,) is all that is financially possible. In 1865 I found on one Rajbuha that Government realized one rupee for each 40,000 cubic feet supplied to rice; the rates have been raised since, however.

The water supply of towns is worked under entirely different conditions. As regards bulk, water is much more valuable for domestic purposes; it is delivered with a great head of pressure, requiring only small sections of pipes, and where meters are employed, they are in places of safety.

The conditions of canal irrigation are similar to those on which land revenue is assessed. Government has to relinquish some part of what it could fairly demand, because the cost of dealing with each individual case, would not be compensated for by the additional revenue obtained. It has to work on averages. Both are affected by the seasons, the diverse peculiarities of the soil, the rights of those who have a lien on the land, and the skill and energy of the cultivator. It is possible to provide each village with one or more small tanks, (in fact artificial artesian wells,) and there appears to be no objection to leaving the further detail of the distribution to the villagers themselves.

All who have attempted to solve the question appear to have aimed at securing a uniform discharge only. Even if such a contrivance was invented and adapted to all cases, would it be of any use? Given such a module, can we dispense with area measurements? Even the module that enables the charge for water by bulk to be made will not answer all purposes, because we not only want to ascertain the amount due from each irrigator, but also how to apportion the supply, so as to obtain the greatest benefit. It is therefore necessary, to consider the following points:—

1. The available supply during a given period of time.
2. The demand during the same period of time.
3. The plans proposed for effecting the distribution after a comparison of supply, demand, and probable rainfall.

CASE No. I.—*The supply available during a given period of time.*

The supply that can be obtained from the river at any time of the year may be ascertained beforehand, the supply to each division will be proportioned to its wants, except when a drought requires that food crops should have precedence.

CASE, No. II.—If an irrigator was called upon to state the number of hours his outlet should be open to irrigate his fields, he could give a fairly accurate answer. It is supposed that he would be told that he would have to pay a fixed sum per hour for the number of hours he stated, to prevent exaggeration, and to prevent overcaution, on the other hand that he would not be allowed to keep it open for one minute longer than the time he specified.

Take the case of a chokidar having charge of a length of Rajbuha on which there are outlets and methods of distribution on standard plans, there is no difficulty about his preparing a form of the following description periodically.

FORM A.

The demand during the same period of time.

Requisition for Water.

Rajbuha, *Raiwind.*
Chokie, *Laddeki.*

Description of Distributing Apparatus.	1	2	3	4	5
	No. worked.	No. of hours worked per day.	No. of days worked.	Cubic feet required.	Cubic feet supplied.
<i>Lift Irrigation.</i>					
Pattern No. 1, ..					
,, No. 2,	&c., &c.
<i>Flow Irrigation.</i>					
Design No. 1, ..					
,, No. 2,	&c., &c.
Total			

Columns Nos. 1, 2 and 3 being filled in by the chokidar after he has ascertained from the irrigators their probable wants; column No. 4 in the canal office, and No. 5 by the official entrusted with the minor distribution.

Supposing these returns were made out for a ten day's supply, they might be written up, forwarded by, and returned to the chokidar during the previous ten days.

On this return would also be shown by the canal office

	Cubic feet.
Total supply for Rajbha,	0'000
Deduct supply to this, and up-stream chokies,	0'000
	0'000
Balance for down-stream chokies = x =	0'000

where x corresponds to depth of water to be maintained during this period at the tail of this chokie. This gauge reading being also entered by canal office.

The chokidar would find no difficulty whatever in making out this return, because the Zemindars soon find out the work their *Mogas* can do, and can state pretty accurately for what length of time they want them open. Yet as they could not state their wants in figures, the entries here made are based on the average discharges of the different descriptions of outlets used. This local knowledge and the fact that the men most interested are consulted, would be more trustworthy than any theoretical methods of determining the demand.

This return needs only a chokidar of ordinary intelligence, and the rest of the work being purely mechanical, can be done by a small number of computers for a whole canal. If there is an objection to giving the duty of making out returns of the demand to the chokidar, certain days might be appointed on which passes for water would be issued at certain chokies along main canal, either by Assistants, Darogahs or Zillahdars.

The returns could be made up from the counterfoils of these passes or cheques. A small fee being levied on them.

Before filling in column No. 5, it may sometimes be necessary to consider the consequences of unforeseen changes in the weather, and to calculate

1. Probable expenditure, weather being average.
2. " " extremely wet.
3. " " " dry.

When there is a continuance of dry weather, as in the khureef of 1868, the canal may have to supply water for maturing crops that were sown in the expectation of a good rainfall. Again wet weather is often followed by extensive sowing, for which the canal may be afterwards called upon to give

water. But a careful analysis of the returns compared with the indications of weather and statistics of previous years, would enable us to make the most of the canals, to lessen the expenditure where it could be done without injury, and to withdraw aid where things had become hopeless.

Practically only cases of very exceptional rainfall or drought will disturb seriously the calculations—with area measurements, irrigators are tempted to over-irrigate their crops, and the range between the maximum and minimum supply that will mature a crop is considerable.

Then again putting it into a different form, some irrigators will require water for

1. Certain irrigation—*i. e.*, crops altogether dependant on canal water.
2. Uncertain irrigation—crops sown after, or in expectation of rain, but from continued dry weather requiring aid from the canal.

And it would not be fair to the canal to allow the same water-right in both cases. In certain irrigation, a failure of the crops through want of water justly entitles the owner to a remission of the water taxes, and even to compensation, provided he can prove that he gave his certain precedence over his uncertain irrigation in all cases when the supply was not equal to the demand. In uncertain irrigation, however, it should be the irrigators own gain or loss, and the precaution will prevent cultivators from gambling, as it were, on the chances of very favorable weather, and rushing to the canal at the last moment for assistance. In making up his indent, a chokidar should separate his certain from his uncertain irrigation.

As our knowledge of meteorological laws advances, so will errors on account of variations in the state of weather decrease. It would not be folly to look forward to reaching such exactness after years of experience that, so far as the control of the water was concerned, canal arrangements might be worked by formulæ. The facts deduced from such data as these, would be more trustworthy than the conclusions arrived at after a hasty gallop through a plot of irrigation with preconceived notions of what its requirements are.

CASE, No. III.—*The plans proposed for effecting the distribution after a comparison of supply, demand, and probable rainfall.*

The destination of every cubic foot of the supply having been determined, we have now to consider the best way of forwarding it to its appointed place, and this case will therefore embrace—

- A. Distribution to Canal Division.
 B. " " Rajbuhas.
 C. " " Rajbuha chokies.
 D. " " each estate.

Distribution to Canal Division.—It is not necessary to do more than refer to a Circular of the late Lieut.-Col. J. Dyas, in which he has pointed out in great detail the arrangements for the distribution to Divisions.

It was for reasons stated in this Circular that the 10 day periods were adopted.

Distribution to Rajbuhas.—It is necessary to show first, that it is quite possible to give the men in charge of Rajbuha Heads such simple instructions and apparatus as will readily enable them to find out the exact discharge at all times, notwithstanding constant changes in the earthen channels from silt deposits, so that when ordered to send down a certain number of cubic feet per second they can do so.

The object sought for is some mode of registering data from which the discharge can be deduced by formulæ, which give the nearest approximations. In ordinary rajbuha channels we find (through the deposition of silt) their wetted perimeters, areas and longitudinal slopes changing their relative values daily, and therefore cannot easily obtain reliable data for

the formula $90 A \sqrt{\frac{R}{s}}$; but given a rectangular orifice, submerged or otherwise, with an appreciable head of water, and we obtain data. The gauge keeper, or guardian of the head, by merely noting the difference of level in supply and distributing channels, and the dimensions of the orifice gives us all the data necessary in calculating the actual discharge, and these data are reliable, so long as there is a sufficient head of water to prevent silt from actually heaping up in the orifice itself.

The objection to this arrangement is that we can never send down as much as the rajbuha will carry; we must always reserve a certain head to ensure the accuracy of the data. Most rajbuhas after silt clearance, however, work for some time with the level of water lower than the canal, and the gradual diminution of this difference would afford an indication of when it was necessary to clear off silt again.

The data for calculating discharges over weirs can be as easily registered as in the case of orifice, but the following formulæ for discharges in uniform

It will be also necessary to have means of tabulating the discharge for all depths at other points, beside the head, on rajbuha: and these points are Escapes—Tail falls—Above irrigating chokie—Below irrigating chokie.

As after the first few miles we scarcely ever find much bed silt in a rajbuha, a simple bar of masonry, 1 foot high, built on the floor of a bridge, would act as a weir, and with gauges up and down-stream suffice for registering the discharge of these points. A weir will suffice here because no regulation is required, but merely means for ascertaining the discharge.*

Distribution to the various Chokies on a Rajbuha.—Under the present system a chokidar has to look after from 4 to 8 or 9 miles of irrigating channel, and instead of his attention being confined to a periodical inspection of the points from which water is drawn from the rajbuhas, he has to find out to what purpose and to what field each man applies his share, and to get each detail he has to traverse the country in all directions. If there are 40 outlets in his beat, there will be, including branches, probably 80 miles of petty channels.

Beyond guesses based on limited personal inspection, there is no guide to indicate what measures should be taken to ensure the best results, and at critical seasons of the year individual irrigators suffer and all lose faith in canals. It is evident that if we withdraw from all interference with the way in which the water is used, and limit ourselves to the issuing of it from our channels, that the grounds for numerous offences now committed will be removed—most of the existing evils can be avoided by a centralized system of distribution, in which the chokidars, unless gifted with great powers of calculation and combination, cannot help being involuntary modules.

The problems are— X is the available supply for a rajbuha during certain ten days, &c.; $x, y, 9$, &c., the cubic feet to be expended in each chokie on it. We have now to consider how the quantities x, y , &c., can be distributed, so that a chokidar cannot take more or less than the quantity assigned to him, and by what means we can do away with the necessity of his stirring a yard from the rajbuha banks on duty; also, taking the first chokie on a rajbuha, how it can be ascertained whether a chokidar is passing on to the chokies below the quantity ($X - x$).

The amount of detail in the present system is owing to no grouping of

* The error from disregarding velocity of approach would not be large.

special cases under general heads, and we cannot undertake to register the quantity supplied to each irrigator, unless they are reduced to a system, and the present practice of putting in *Mogaz* at all points of the channel discontinued. We have

1. A number of *Mogaz* and shareholders.
2. Fluctuations of the water level in *rajbuha*.
3. Time.

The number of outlets and fluctuations of the water level are not so important as the regulation of time, and this the *chokidar* can only do when the outlets are grouped together, and in this way admit of constant supervision.

The distributing arrangements proposed are as follows:—

1. The bulk of the supply from a point conveniently situated for easy command of the less scattered portion of the irrigation. This also being the head quarters of the *chokidars*, and usually placed where the lands are above the bed of the *rajbuha*, and therefore not admitting of a clear fall from the outlets.

2. By self-registering meters at places where there is a clear fall at all times.

3. In some cases from convenient points in the lands of important villages, supposing the men fit to be entrusted with the management of the details of the distribution, the *chokidar* merely noting the gross amount supplied.

4. The remainder to machines for raising water.

The *chokidar* would prepare lists of the irrigators and the quantities to be supplied to each during a certain ten days, grouped under the four methods of issuing the water.

Besides serving out water, the *chokidar* must be able to ascertain whether he is receiving his allowance, and passing on the quantity ordered to the *chokies* below.

This he can do by observing the head of water at the weir at the tail end of his *chokie*, and looking up the discharge from his table.

Distribution to villages and to individual irrigators.—The steps necessary to determine the supply to each canal, each *rajbuha*, and each *chokie*, or beat having been given, it is necessary to determine how the extent and level of the irrigated plots will affect our distributing arrangements, *i. e.*, we have to give the means or appliances which will enable the

chokidar to divide the quantity ($X - x$) among the irrigators whose land lie along his bit of rajbuha.

The water may either be sold wholesale to bodies of irrigators, or retail to individuals. At present even there are numbers of men not shareholders, who by being connected with some one who has shares, or by paying a certain tax to the chief shareholder, manage to obtain canal water.

By extending this system, we may in most cases reduce the number of shareholders by retaining only representative men, who, would also arrange for the irrigation of all those connected with them in any way. If we bear in mind the various customs existing in every village, this system would appear to be the best suited for natives of Upper India. So far as the internal economy of villages is concerned, they are almost self-governing. Government will be also at liberty to enter into contracts for the constant supply of water—*i. e.*, men could purchase the right of the use of an outlet for specified days during a crop, all the water supplied in this way being entered in the returns as certain irrigation.

The simplicity of the arrangements depends entirely on the description of country the rajbuha runs through, and this fortunately happens to be in their favor, for nearly all rajbuhas traverse extensive plains, and these being nearly on a dead level, afford every facility for massing the irrigation outlets at a few, instead of at numerous points on the channel. Besides the country being a new one, we have not in most cases to suit our arrangements to the state of things existing, but the circumstances developed in time to come, will accommodate themselves to the network of irrigating channels.

In the sketch, (*Plate LIX.*) the plots of irrigation A, A, A are supposed to be above the level of full supply in the rajbuha, and therefore require the aid of machinery. The plots B, B, B below full, and above low, supply, and the plots C, C, C below the bed of rajbuha, so that the smallest trickle would run on to them.

The distribution of the bulk of the supply from the head-quarters of the Chokidar.—A point could be selected on the channel, so as to be convenient for the supply of water to the irrigated plots B, B, B. Should it also command parts of the plots C, C, C these portions also might take their supply direct from the chokidar, and in such cases meters would not be required. For the details of this, *vide* Paper Nos. CLXVII. and CCXI. of the "Roorkee Professional Papers on Indian Engineering," [First Series].

Those portions not lying close to the chokidars, but being provided for by

Plan No. 2. Self-registering meters at places favorable to the introduction of Mechanism, i. e., where the fall from the outlet is sufficient to do away with any chance of their being any back water to stop the moving parts. These waters might either be simple orifices with a uniform discharge, or clock-work arrangements, by which the sum of the velocities could be recorded, the shareholders arranging their turns and times among themselves, exactly as they do now with the ordinary "Moga." Any of the following contrivances might be used:—

- A. Meter noting sum of velocities.
- B. Meter—an intermediate chamber the water alternately rising and falling. The number of risings and fallings being noted, and the discharges deduced therefrom.
- C. Meter with uniform discharge and time opened registered.

Besides these, other contrivances are possible, because the conditions are restricted and well defined.

This plan of dealing with a chief irrigator may be extended, so as to permit of our dealing with whole villages as in,—

*Plan No. 3. Distribution in some instances from convenient points in the lands of a village; the irrigators being entrusted with the details.—*Suppose a village possessed a spring of water, or an artesian well supplying enough water for the irrigation of its lands, there is no doubt but that the villagers would soon adopt customs suited to the sharing of its benefits fairly, and that the calling in of Government to act as distributor would be the last thing thought of.

It would simply be an extension of the present share-system in the case of well irrigation. *Practically* we can in nearly every instance place on the lands of a village this spring or artesian well.

The simplest arrangement would be a small tank (say 16 feet square), built on the highest spot in the village lands, and provided with numerous orifices of the same size and at the same level; this tank being connected by a channel with the rajbaha at the chokidar's hut, where there would be a regulator to maintain a constant head of water. The discharge through each orifice being the same, we know that if 8 men were taking water at the same time that each should be charged for one-eighth of the supply registered by the chokidar.

In large villages there might be one of the tanks in each lumbardas "patti."

SKETCH OF DISTRIBUTING ARRANGEMENTS.

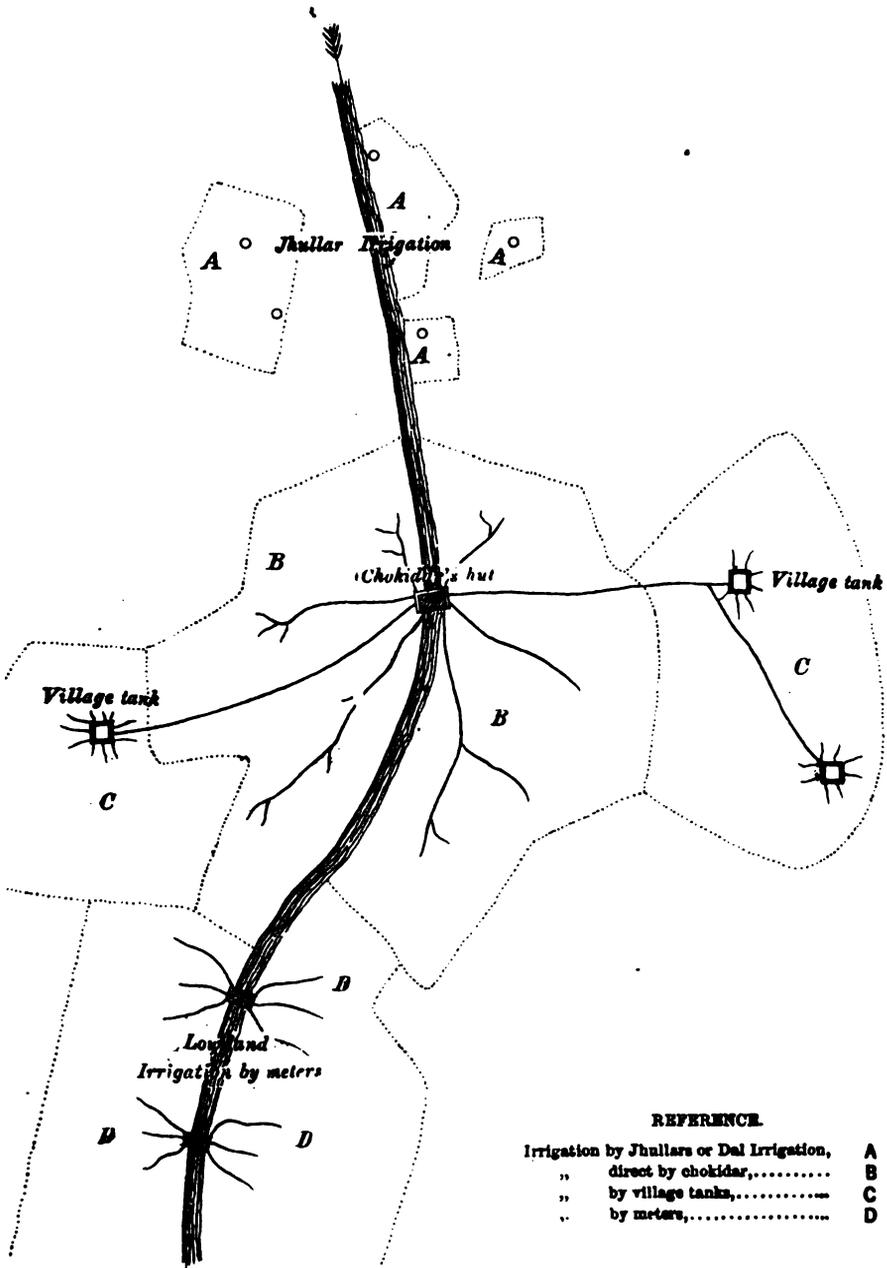

REFERENCE.

- Irrigation by Jhullars or Dal Irrigation, A
- " direct by chokidar,..... B
- " by village tanks,..... C
- " by meters,..... D



We have now to provide for raised irrigation, which is but an insignificant portion.

Plan No. 4. Distribution to machines for lift irrigation.—Nearly all the water for lift irrigation on the Baree Doab Canal is lifted by Jhullars, and they have

1. A single line of pots, small size.
2. " " large "
3. A double line of pots, small "
4. " " large "

As all these are worked by bullocks, the angular velocity is about the same in each instance, so given the number of revolutions, and making allowances for spillage, the quantity raised is easily calculated, a record of the revolutions might be kept by a meter attached to the driving gear. A fixed sum for each description of machine charged by the day or by the crops would probably be most convenient. This is done on the Multan Canals.

As Jhullars for small lifts are by no means economical, enterprising irrigators might be induced to set up any of the following, the driving gear being the same as it is now:—

- Scoop wheels, with mechanical register.
- Cellular " " "
- Tympanum " " "

But whatever machine is used, it must belong to some class, before the returns of the demand can be made out.

In a few words to ensure a judicious distribution of the supply and reliable measurements of the quantities issued to each irrigator, it is only requisite to have—

1. Returns of the demand.
2. Simple arrangement (common sluices) at the heads of rajbuhas to regulate the supply.
3. The massing of the outlets at convenient points.
4. Village tanks and meters, the latter not actually necessary.
5. A classification of the machines used for lifting water.
6. Tables of discharges.

With reference to the determination of the supply, it must be borne in mind that a certain percentage will be lost by absorption, and a portion in its passage from the head of the canal to the rajbuha. The loss from

absorption will vary indirectly as the velocity, and directly as the depth and porosity of the bed, but the effect of the velocity and depth on the results will be scarcely appreciable.

The loss from absorption in village channels is much greater, both because they are alternately wet and dry, and for a given quantity of water sent down have usually much tracer channels. But the loss would not affect our measurements because it takes place afterwards.

The introduction of payment by volume may induce the cultivator to supplement the canal supply by every drop of water they can procure elsewhere, such as from tanks, wells, &c. In times of drought, like in 1868, enhancement of the water rates would make men work their wells more in districts where the springs were close to the surface, and thus enable us to give greater assistance to tracts where it is not possible to get water from any other source but the canals.

There are serious objections to enhancement of the rates at any time, but in times of great need, it might be the best way of meeting the demand, and to be preferred to "tateelin" long lines of channels, for we may be sure only those will take at the higher rates who would otherwise suffer severely.

E. A. S.

No. XCV.

FAILURE OF THE PUENTES DAM.

[*Vide Fig. 7, Plate VII., Nos. LXVIII., Second Series, Professional Papers on Indian Engineering (February, 1873).*]

BY CAPT C. E. SHEPHERD, B.S.C., *Assoc. Inst. C.E.*

IN Number VII., Volume II., published in February 1873, in a Paper No. LXVIII., entitled "*Masonry versus Earthen Dams,*" by Major Hector Tulloch, R.E., there is what I consider an error on the part of the author of the paper, to which I would beg to draw attention.

To the Engineer failures are more often productive of useful lessons, than perhaps are successes, and to have an incorrect notion of the cause of a failure, doubtless would lead to wrong conclusions—it is to correct what I consider an erroneous notion in Major Tulloch's paper, that I am induced to write this Article. After enumerating the first two causes of how a masonry dam gives, Major Tulloch goes on to state the third cause by saying, "Every dam that has been destroyed hitherto has crushed in from its own weight:" and goes on—To look at the dam of Puentes, *vide Plate VII., Fig. 7*, one would at first be induced to think that such a cyclopean structure would almost have answered to stem the tide between the Pillars of Hercules. But what is the fact? The giant succumbed not from the thrust of his adversary, but from his own weight. In fact he was too heavy for his work. The ground literally could not sustain him, and in 1802 he was *hors de combat.*"

So far for Major Tulloch's description of the failure of the dam at Puentes. Allow me now to quote from a French work (full of interesting information to any Engineer, more especially to such engaged on River or Dam Irrigation Projects, and which goes most carefully and completely into the various dams and canals constructed in the South of Spain),

entitled "Irrigations en Mill de l'Espagne, par Maurice Aymard, Ingenieur des Ponts et Chaussées:" from pages 254 to 259, the author gives a complete history of the commencement, with a detail account by an eye-witness of the failure of this dam. I must endeavour to condense and translate the same. I give no dimensions of the dam itself, as these can be got from Major Tullock's papers and plans. The dam was built between the years 1785 and 1791. It was in use for eleven years, and was destroyed on the 30th April, 1802. The two banks of the river across which the dam was made were of rock, but in the middle of the bed, the rock did not show, and there is nothing but sand and gravel. It was considered that it would always be possible by a drainage channel to lay bare the junction of the two rocky sides across the bed, and the project was drawn up on this hypothesis. During the course of construction, the means of drainage employed could not keep the excavation in the gravel dry; a sounding taken showed no rock at a depth of 7.5 metres (24.6 feet). They then took the fatal resolution to found on piles across the whole of this weak space, and piles accordingly of 6.7 metres (22 feet nearly) were driven in *quinconce*, and bound together with cross pieces, and the heads of the piles which projected well above the level of the cross pieces, were buried in the thickness of the foundation masonry which was only carried down 2.25 metres (7.38 feet) into the gravel. This pile work was carried down-stream from the dam for a distance of 40 metres, 131.2 feet. This was also covered with masonry 2.25 metres in depth, and formed an apron to protect the bed from erosion from the waters, whether brought out by the discharge or scouring sluices.

"This foundation was not thoroughly defective, and would perhaps have lasted for ever, had the barrage been of less height, say for instance 20 to 25 metres (65.6 to 82 feet). The proof of which is, that it worked for 11 years, a space of time during which the rain was never sufficient to raise the waters more than one-half the height. But on the 30th April, 1802, the water rose to about 47 metres, (154.16 feet), and the foundation gave."

Monsieur Aymard then proceeds to translate the account of an eye-witness, which I also condense.

"About half past two on the afternoon of the 30th April, 1802, it was seen that on the down-stream side of the barrage towards the apron, water was issuing in great quantities in bubbles extending in the shape of a palm tree, and of an exceedingly red color. About three o'clock, there was an

explosion in the discharge wells that were carried through the barrage from the top to the bottom, at the same time the water escaping on the downstream side increased in volume. In a short time, a second explosion was heard, and enveloped in an enormous mass of water, the piles, cross, and other pieces of wood that formed the pile work of the foundation, and the apron, as well, were seen to jump out.

“Immediately after, new explosion, the two big gates that shut the scouring sluices, and the intermediate pier fell in, and at the same instant escaped a mountain of water in the form of an arc, frightful to see, and which was of a red color like fire, caused either by the mud with which it was charged, or by the reflection of the sun. The volume of water which escaped was so considerable, that the reservoir was emptied in the space of one hour.

“The barrage now presents the appearance of a bridge, of which the abutments are the work founded on the hill sides, and of which the opening is about 17 metres broad ($55\frac{1}{2}$ feet) by 33 metres high ($108\frac{1}{2}$ feet).”

I will now quote Monsieur Aymard's conclusion from the above: he says—

“The account we have just written is as clear as possible, and leaves no doubt as to the manner in which the barrage was carried away.

“It was neither an overturning of the masonry, or an undermining in the ordinary sense of the word, it was a violent expulsion of the sub-soil caused by the pressure of the waters.”

In the above conclusion, I agree with Monsieur Aymard. The weak soil was blown out by the pressure of water at the back of the dam, at the time there was 33·4 metres ($109\frac{1}{2}$ feet) depth of water, and 13·4 metres depth of silt (44 feet nearly).

I think the clear account given in Monsieur Aymard's book, points out the cause of failure, viz., the foundation piles, sub-soil, &c., were blown out by the pressure of the water, and that failure was not due as ascribed by Major Tulloch to any settling of the sub-soil under the mass of masonry that it supported, a view which is also negatived, by the fact of its lasting eleven years intact, and only succumbing when a heavy water pressure bore against it.

The wish to prevent an erroneous conclusion is my sole apology for writing this ‘Note,’ and that of stating my grounds clearly for considering the conclusion erroneous, must be my apology for its length.

C. E. S.

No XCVI.

RESISTANCE OF SANDSTONE AND MORTAR TO
THERUSTING STRESS.

Report by G. W. MANSFIELD, Esq., *Engl. Engineer, Indian Service*
To—The Chief Engineer, *Coastal Provinces.*

23 April 1872

I HAVE the honor to forward original letters with table of experiments & the strength of the series of sandstone just received from Messrs. Kirkaldy & Co. of London. The respective ages of the stone cubes at the time the experiment was made, are indicated by letters on the margin of the table. With regard to this information, which is of great value I would beg to make the following remarks. I have always been of opinion that the Scottish sandstone was of a very weak description, but I confess I was hardly prepared to find that it was so much below the most inferior sandstones employed in England, which usually will resist a pressure of 2,000 lbs. per square inch, and this was about the value had hitherto given to the stone. The cubes sent to Messrs. Kirkaldy were not only of different ages from the quarry, but each pair, A, B, C were of different qualities, selected from the various stones actually in use for building.

With the data now available, I have made the following calculation which, however, I should much like to be checked over by others. As regards the horizontal pressure on the key and the sufficiency of the key allowed:—

Let B = Radius of curvature at crown	=	$\frac{95 \cdot 05}{2}$
d = Depth of keystone	= 4.25
b = Breadth	= 1
w = Vertical weight on a foot of keystone, including its own weight as follows:—		

	lbs.	lbs.
Own weight = 4.25×122 lbs.,	= 518½	
Weight of roadway = 1 cubic foot, @ 122 lbs.,	= 122	
Live load, @ 1 ton per foot run of bridge, = per square foot,	= 112	
w = Total Vertical do. per foot,	=	752½
C = Weight required to crush a square foot of the sandstone in lbs., which is ac- cording to Messrs. Kirkaldy's test—		
$1,066 \times 144$,	= 1,53,504	
P = Horizontal pressure on key.		
Then P = Rbw		
$= 95.05 \times 1 \times 752½$ lbs.,	=	71,525

and strength of arch is proportional to $= \frac{dC}{Rw} = \frac{4.25 \times 1,53,504}{95.05 \times 752½} = \frac{6,52,392}{71,525} = 9.12$,

that is, the strain on the arch when loaded will be 9.12 times less than would cause it to yield by crushing.

Rankine's formula for horizontal thrust at the key gives the same as above, viz. :—

$$T = D \times W \times R$$

$$= 4.25 \times \left\{ 122 \text{ lbs.} + \frac{\text{lbs.}}{4.25} (122 + 112) \right\} \times 95.06$$

$$= 4.25 + 177.06 \text{ lbs.} + 95.05 = 71,525 \text{ lbs.}$$

The following is the value of $\frac{dC}{Rw}$ for several bridges of note :—

Name and Situation of Bridge.	Radius of curvature of the arch in feet at crown.	Value of $\frac{dC}{Rw}$ or number of times that the pressure on the keystone must be in- creased to crush it.
Bridge carrying the Great Western Railway over the Thames at Maidenhead,	169	3
Neully Bridge over the Seine at Paris,	260	5
Bridge of the Holy Trinity at Florence,	172.6	21
Bridge over the Dee at Chester,	140	22
Bridge over the Dora Riparia, Turin,	160	44
London Bridge,	162	40
Waterloo Bridge,	112.5	68
Kanhan Bridge,	95.05	9.12

The above shows how much care should be taken in the selection of

stones for the building, and that no economy would result from any attempt to save first cost by any jolting and shoving stones of which there is the smallest suspicion.

Copy of a letter from DAVID KERRIDGE, Esq., to G. W. MACGILLIVRAY, Esq., C.E., Econ. Engineer, Edinburgh, Scotland.

London, 25th March 1872.

I duly received your esteemed letter of 21st Nov. inst., and the crates did not arrive here until 1st March. Previous to testing them I jolted two of the faces parallel and then tested them in my usual manner, and I herewith enclose report containing the particulars.

The mean result at which they cracked slightly was 1,066 lbs. per square inch, and 1,253 lbs. when they were crushed.

The best English sandstone that I have as yet tested, crushed at 5,105 lbs. per square inch, the texture very fine and uniform. A much coarser quality crushed with 2,161 lbs.

Results of Experiments, illustrating the resistance to Tumbling Stones of six cubes of yellow Sandstone with the results received per Messrs. Grubb, Lang, Green & Co.

Test number.	Marked.	Dimensions.	Mean area.	CRACKED SLIGHTLY			CRACKED, STRENGTH REDUCED		
				Stress.	Strain.	Per cent.	Stress.	Strain.	Per cent.
G.		Inches	sq. in.	lbs.	lbs.	per cent.	lbs.	lbs.	per cent.
920	May, No. 2 A.	6.00 x 6.00 x 6.00	36.00	46,920	1,265	53.3	49,440	1,364	57.7
923	Sept., No. 1 C.	6.00 x 6.16 x 6.11	37.43	46,083	1,224	79.7	49,140	1,316	54.0
919	May, No. 1 A.	6.00 x 6.00 x 6.00	36.00	36,720	1,020	65.6	44,780	1,244	59.0
924	Sept., No. 2 C.	5.96 x 6.07 x 5.97	36.11	37,060	1,022	65.7	44,420	1,225	57.9
922	July, No. 2 B.	5.90 x 6.17 x 6.05	37.32	34,970	937	60.3	44.45	1,192	76.7
921	July, No. 1 B.	6.00 x 6.07 x 5.99	35.76	32.24	901	57.9	42.44	1,157	76.8
				Mean.	1,066	68.6	Mean.	1,253	8.6

All bedded between pieces of pine, one-quarter inch thick.

D. K.

NOTE.—Ages of sandstone from quarry at time of test—a, ten months; b, six months; c, ten months; d, six months; e, eight months; f, eight months.

*Report by G. W. MACGEORGE, Esq., Exec. Engineer, Kanhan Division.
To—The Chief Engineer, Central Provinces.*

10th November, 1872.

I have the honor to forward original letter, with a table showing results of experiments to ascertain the resistance to thrusting stress of ten specimens of sandstones and two of mortar, sent by order, to Messrs. Kirkaldy, Southwark, London, for test.

By inspection of the table, it will be seen that the first six specimens sent were three years from the quarry, Nos. 7 and 8 were six months, and Nos. 9 and 10 were three months from the quarry. The specimens of mortar were about two years old.

The specimens selected were of all the various qualities, fineness, coarseness, color, &c., that are in actual use for arch stones for the Kanhan Bridge; duplicate specimens were in *each case* retained for comparison with the recorded results of the test when received.

Taking the average of the first specimens previously sent (*last year*) at 1,066 lbs. per square inch, and their age at six months, there is evidently a very considerable improvement in the results, as shown by the present tests. I am inclined to the opinion that the very low results given by the first specimens must be partly attributable to some injury experienced by the cubes of stone in transit. The specimens were sent in an unlined packing case, and they arrived at and were tested in England in the depth of a very severe winter: it is possible, therefore, that the cubes of stones may in the ship's hold have been affected by contact with salt water, or may have been injured by frost in England.

The dozen specimens, of which the test results are now received, were sent in a *tin-lined* case, and were tested in England at the end of the summer.

The mean results of the several specimens, as shown in the enclosed table, exhibit very plainly the effect of *time* in hardening these sandstones, and no doubt they will continue to harden to some extent in the work in course of years. It is, however, evident that up to a limit of age of three years from the quarry, the stone barely approaches in strength to the inferior English sandstones that are recorded in tables of strengths of materials, which is 2,000 lbs. on the square inch.

It will be seen by the calculations given in my letter No. 66-597, dated

8th April, 1872, that the horizontal pressure at the crown of these arches is 71,525 lbs., say 72,000 lbs., and the theoretical strength of the arch is proportional to $\frac{dC}{Rw}$

Where d = depth of keystone.

C = crushing weight per square foot of the stone, which we may now take at $1,500 \times 144 = 2,16,000$ lbs.

R = radius of curvature at crown.

w = vertical weight on a foot of keystone including its own weight, and which was shown to be $752\frac{1}{2}$ lbs.

We have then as above—

$$\frac{dC}{Rw} = \frac{4.25 \times 2,16,000}{95.05 \times 752\frac{1}{2}} = \frac{9,15,000}{72,000} = 12.75.$$

That is, the strain in the arch when loaded will be 12.75 times less than would cause it to yield by crushing.

I have taken the average crushing strain per square inch from the table at 1,500 lbs. only, as few of the stones composing the arches are more than six months from the quarry; but even if 2,000 lbs. per square inch be allowed, equal to the most inferior English sandstones used for constructive purposes, the actual stress in the arches would be as high as $\frac{1}{17}$ of their crushing stress, when from $\frac{1}{25}$ to $\frac{1}{30}$ are the usual ratios.

Copy of letter from DAVID KIRKALDY, Esq. To—The Exec. Engineer, Kanhan Division, Central Provinces.

London, 11th Oct., 1872.

I have again the pleasure of sending you report of experiments on cubes of stone and mortar. I placed all the stones on their natural bed

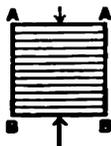
thus: and before putting them in  to the Testing Machine, I

had the two surfaces A and B made parallel to insure correct results.

I am now very busy testing a very fine series of forty-eight specimens of six kinds of stones from Bombay.

4 blocks $6 \times 6 \times 6$ }
 4 „ $6 \times 6 \times 12$ } of each kind, which will give a very good average.

Result of Experiments to ascertain the resistance to Thrusting Stress of ten cubes of various Sandstones and two of Mortar, received per Messrs. Grindlay, Groom & Co.

Test No.	Marked.	Dimensions.	Base area.	CRACKED SLIGHTLY.			CRUSHED, STEEL-YARD DROPPED.		
				Stress.	Per square inch.	Per square foot.	Stress.	Per square inch.	Per square foot.
G.		Inches.	Sq. Ins.	Rs.	Rs.	tons.	Rs.	Rs.	tons.
3047	1 3 Y	6.12 6.17 × 6.15	37.94	74,160	1,954	125.7	88,780	2,340	150.5
3048	2 3 Y	6.10 6.10 × 6.10	37.21	68,240	1,834	117.3	79,870	2,146	138.0
3049	3 3 Y	6.26 6.25 × 6.10	38.12	48,970	1,284	82.6	58,740	1,541	99.1
3050	4 3 Y	6.10 6.15 × 6.17	37.94	69,820	1,840	118.3	74,180	1,955	125.7
3051	5 3 Y	5.98 6.10 × 6.10	37.21	62,980	1,693	108.9	69,270	1,861	119.7
3052	6 6 M	6.00 5.90 × 6.00	35.40	51,076	1,443	92.8	54,744	1,546	99.4
3053	7 6 M	6.00 5.95 × 6.00	35.70	40,780	1,142	73.4	49,960	1,399	90.0
3054	8 6 M	5.92 5.96 × 5.98	35.64	46,480	1,304	83.8	62,180	1,745	112.2
3055	9 6 M	5.94 6.04 × 6.00	36.24	43,340	1,196	76.9	51,320	1,413	90.9
3056	10 6 M	5.80 5.90 × 5.95	35.10	40,290	1,148	73.8	45,910	1,308	84.1
*3057	11 2 Y	6.00 6.02 × 5.95	35.82	35,980	1,004	64.6	41,810	1,168	75.1
†3058	12 2 Y	6.00 6.06 × 5.98	36.24	34,320	947	60.9	40,730	1,124	72.3

All bedded between pieces of pine, one-quarter inch thick.

D. K.

* Soorkhee mortar. † Sand mortar.

NOTE by T. W. ARMSTRONG, Esq., *Offg. Secy. to. Chief Comr., C. P.*

Nagpore, 20th January, 1873.

It will be seen from the table of experiments sent by Mr. Kirkaldy, of London, that the specimens of sandstone last received by him from Kamthi have proved to be capable of resisting a much higher crushing power, than the specimens of sandstone first forwarded to the same gentleman by the Executive Engineer, at Mr. Armstrong's request.

The specimens first sent were not so long quarried as those forwarded in 1872. Six of the cubes of that year were three years quarried, and they crushed under a stress of from 1,546 lbs. per square inch up to 2,340 lbs., whereas the cubes sent in November, 1871, crushed under a stress varying from 1,187 lbs. to 1,364 lbs. per square inch. The ages of these latter cubes, as counted from the date the stone left the quarry, varies from six to ten months.

The general result of the experiments last made may be said to be, that the stone used at the Kanhan Bridge improves in hardness and solidity considerably after removal from the quarries, and that when six months quarried, its average crushing strain per square inch may be taken at 1,500 lbs.; calculating on this, the strain in the arches when loaded will be at the crown $12\frac{3}{4}$ times less than would cause the stone to yield by crushing,—there is no doubt, however, but that the arch stones will harden by age; this is clearly proved by Mr. Kirkaldy's experiments, and 2,000 lbs. per square inch may be safely taken as the average crushing strain for fully seasoned stones. Under this data, the actual stress in the arches would be seventeen times less than the crushing stress.

Two 6-inch cubes of the mortar used at the Kanhan Bridge Works were sent to Mr. Kirkaldy to experiment upon, the results he reports are satisfactory.

The cubes of mortar are numbered 3,057 and 3,058 in the table of experiments. The following is a description of these mortar cubes; the pressure necessary to crush them is taken from Mr. Kirkaldy's table, and the tenacity given is the result of experiments made by Mr. Wallace, Assistant Engineer, Kanhan Bridge:—

(1). KANHAN BRIDGE WORKS.

Specimen of soorkhee mortar used in foundations.

Proportions.—Two parts soorkhee, one part kunkur lime, age of mortar about two years. Crushed under a pressure of 1,168 lbs. per square inch, equal to 75·1 tons per square foot.

Tenacity by experiment equal to 90 lbs. per square inch.

(2). KANHAN BRIDGE WORKS.

Specimen of sand mortar used at the Kanhan Bridge Works above low water level.

Proportions.—Two parts river sand, one part kunkur lime, age of mortar about two years. Crushed under a pressure of 1,124 lbs. per square inch, equal to 72·3 tons per square foot.

Tenacity of mortar by experiment equal to 46 lbs. per square inch.

The only quarries near Kamthi are those from which the Kanhan Bridge has been built.

T. W. A.

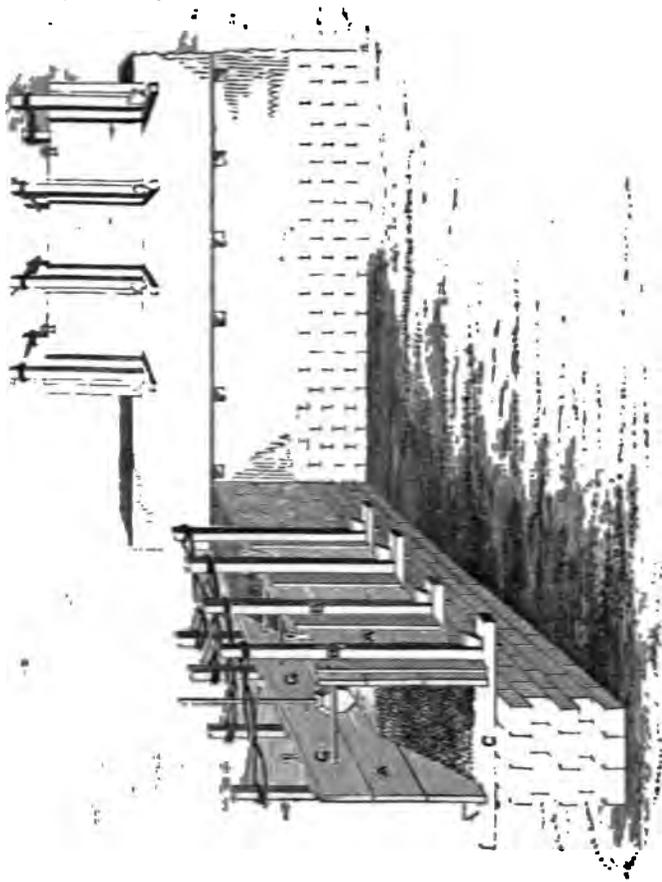

No. XCVII.

ON BUILDING IN PISÉ.

Extracted from Manual on Earthwork. ED. BY COL. R. MACLAGAN,
R.E., with additional Notes and Report.

THIS is a method of constructing solid walls of rammed earth, the form and dimensions of the walls being regulated by a temporary casing of strong planks, within which the earth is rammed. A hard, solid structure is thus produced, of great firmness and durability even under exposure to extremes of temperature and varieties of weather.

The following is a description of the ordinary method of proceeding, taken chiefly from that in practice in the South of France, where this kind of construction is frequent.

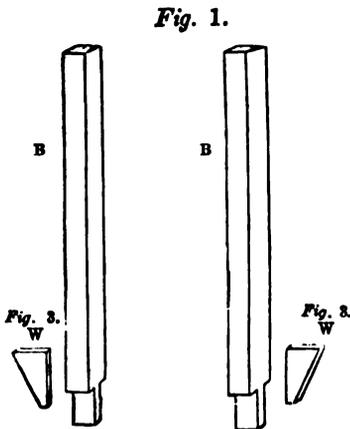

1, inserted at foot in cross pieces CC. The insertion is in long mortises

The wooden casing above-mentioned is represented on page 408, AA are the boarded sides, made of stout smooth planks (the adjoining edges of which may, for greater security, be *ploughed and tongued*), strengthened by cross planks firmly nailed or screwed to the former, to prevent them from warping. Similar boardings are erected, as shown in the figure, on both sides of the intended wall, and they are retained in their relative positions at the required distance apart by upright stanchions BB, *Fig.*

MM, *Fig. 2*, which besides the tenon at the foot of the uprights receive wedges WW, *Fig. 3*, by means

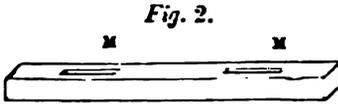

of which the distance apart of the two sides is regulated. Walls in Pisé are generally made to diminish in

thickness towards the top. These cross pieces, as the work proceeds, become so firmly imbedded in the wall, that there is great difficulty in extracting them, to remedy which iron bars have been substituted.* Even these thin iron bars become so tightly jammed when surrounded by the compact Pisé earth, that much labor and risk of injury to the work is incurred in extricating them, and the expedient of setting them in a bed of sand has been successfully resorted to. They are then drawn out with care,—the sand also is removed, and the holes which they leave are subsequently filled with the same earth of which the wall is made, and rammed hard.

This difficulty in the use of wooden bars does not seem to have been experienced to the same extent in Pisé construction in the Madras Presidency, described in the 1st Volume of the Professional Papers of the Madras Engineers. It is stated that several heavy blows of a mallet on the narrow end were required, after which their tapering form made it easy to withdraw them. The soil, it is true, was in this case found afterwards, on the destruction of part of the wall by rain, so sandy, as to be in the opinion of the Engineer, unfit for the construction of such a wall; but when subsequently improved by an admixture of potter's earth, the work progressed satisfactorily, and no allusion is made to any increased difficulty in the removal of the bars. *Tapering* bars are not stated to be used in the French Pisé works, nor were they in the first attempts at Bareilly.

The heads of the opposite uprights are held together by ropes as shown in the figure, but in practice in this country it has been found that, under the immense pressure exerted upon the plank sides by the earth firmly rammed in the interior, the ropes are so liable to stretch, and to break, that it is advisable to use iron rods or bars in this position also. When ropes are used, the distance between the side planks

* At Bareilly—where much useful practical experience in Pisé work has been acquired.
(See additional Notes.)

is measured by gange rods G, (*see* page 408,) and the ropes tightened when requisite to preserve the proper breadth of wall. The use of iron connecting rods renders this unnecessary. The

Fig. 4.

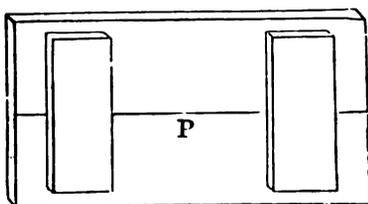

head of the first portion of the work is closed with the piece of planking P, Fig. 4. K, Fig. 5, is a form of iron rod or bolt used for retaining this end plank.

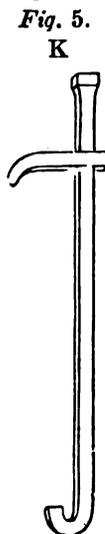

Soil of a medium quality, that is neither very stiff nor very sandy, is considered best adapted for Pisé. It may be said that, that which would make good bricks will answer well for this description of work.

The natural moisture of many soils is sufficient, requiring no water to be added, to make it cohere in a compact mass when rammed. When the earth is very dry, a sprinkling of water will be necessary.

It is usual to begin the work upon a foundation of brick or masonry; but there seems to be no reason why the Pisé might not be used from the commencement, even for foundations under ground; being carefully guarded from all chance of injury by running water.

The casing being prepared and erected, and the upper surface of the

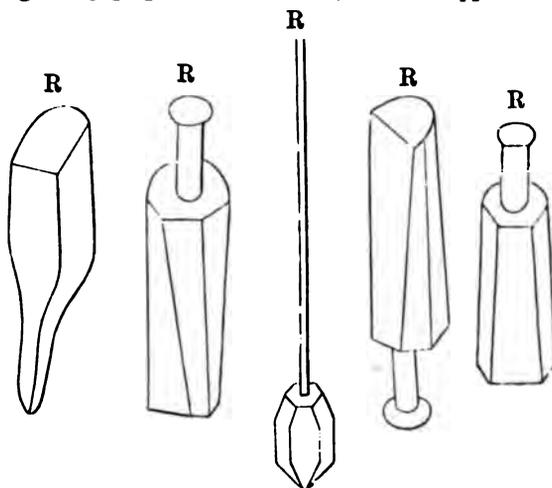

old work, when above the first stage, being sprinkled with water, the

earth, well mixed and slightly moistened, is thrown in, and spread in thin layers of four or five inches. These should, when rammed, be reduced to one-half their original thickness. The rammers RRR should be of hard wood and very smooth. The successive layers are similarly treated, and thus the work proceeds until the top of the casing is reached. The ends of each portion should be finished with a slope, to which will be joined the portion next to be added longitudinally. These joinings should not, in the successive courses, be above those of the lower stage, but as in masonry and brickwork, should "break joint." The seams are all distinctly perceptible when the work is complete. If it be desired to remedy this, either the wall may have a coating of plaster, or the surface may be simply smoothed and dressed with a shovel, or similar implement. When it is to be plastered, it is necessary that the wall should first be thoroughly dry. If dry only externally whilst damp within, it has been found that the moisture is apt subsequently to attack the plaster and cause it to fall off in flakes. Without plaster, good Pisé work is found successfully to withstand exposure to the weather, and after the lapse of many years to be so compact and hard, as to be picked down with difficulty.

Where the wall is not that of a roofed building, it must be provided with a coping, having a good projection to protect it from rain.

The following diagrams show the details, and several implements required, which require no explanation.

Implements required in Building in Pisé.

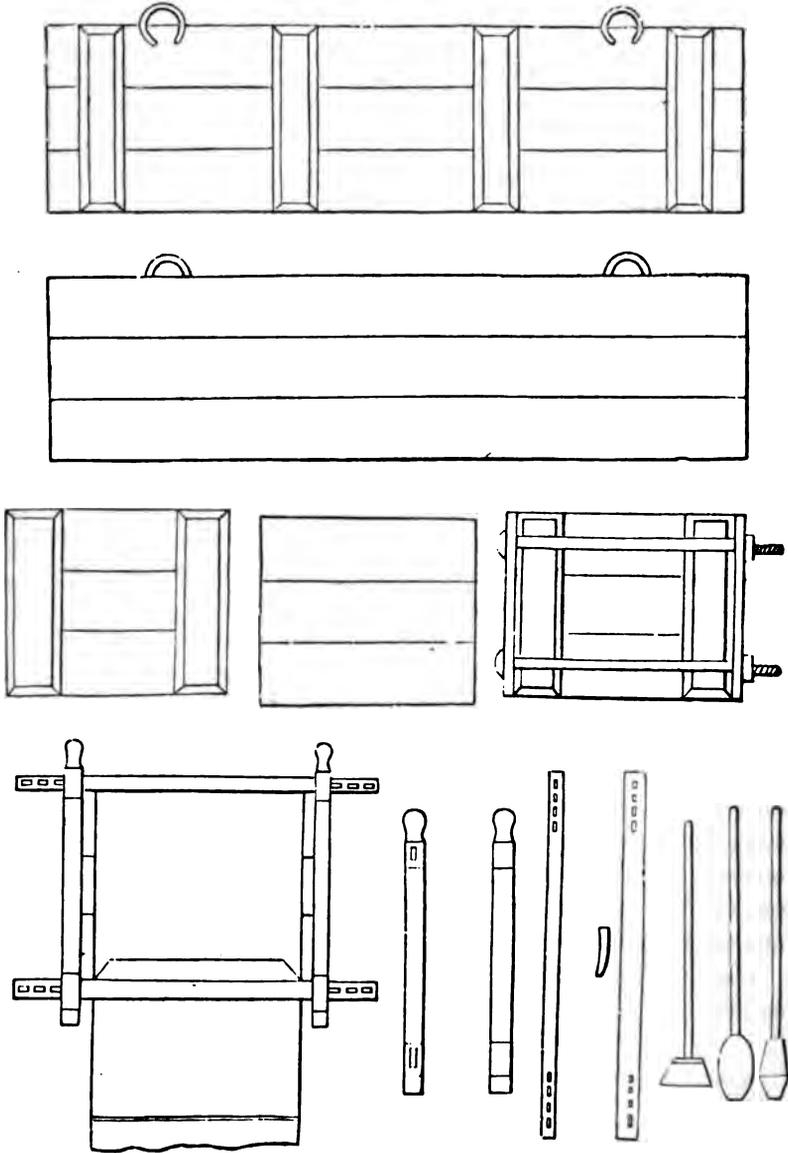

*Additional Notes by F. WILLIAMS, Esq., Collector and Magistrate of Bareilly.**

The most convenient length of planking is about ten feet—the height of the box-work two feet six inches to three feet. The best planks for the purpose have been found to be what are called *mullahee tukhtah*, or boat planks, which, being well seasoned, are generally less liable than others to warp and crack.

The rammer, No. 12, is used for the edge or side of each layer of earth, where it meets the boarded sides, and on the effectual use of this implement will depend the *finish* of the surface of the work, and its capability of standing exposure to the weather. The upper edges of each course of the work will on completion, have the form shown in No. 6, due to the action of this rammer.

The substitution of iron connecting bars for the wooden ones, has been mentioned above. The evils of the wooden arrangement were found to be—the starting of the wedges—the fracture of the tenons—the tight jamming of the bars in the wall, and the injury to the walls and to the bars themselves from the force requisite to be applied for extracting them. The lower iron connecting bars are made three and a half inches by half an inch; the upper, one inch by one-third or one-quarter of an inch each, having holes half an inch by one-quarter, with corresponding pins.

The mode of setting the bars and arranging the work on each successive elevation of the casing, is to cut on the surface of the completed part of the wall a groove one inch wider than the bar, filling it in, after placing the bar, with sand, to the level of the wall's surface. The side boarding being set up, the vacant space left along the bevelled edge of the previous course is filled up with moist clay to retain the first layer of the new course. The end pieces are secured by iron bars or rods, with screws and nuts as shown in the figure †.

Four men are employed on ten feet of wall inside the casing, and two outside, to prepare and supply the earth.

* In connection with the Jail building at Bareilly.

† A convenient arrangement might be,—to make the lower and upper connecting bars alike, to raise the side boarding a few inches above the upper bars, which when imbedded, might be allowed to remain and become the lower ones of the next course; the external apparatus being shifted, by taking out the pins and slipping off the stanchions and planks to be re-applied to the upper bars already in position to receive them.

Three days is the length of time required for executing the same extent of wall two and a half feet high, and three feet thick. Two days, when two feet thick. The work cannot with any advantage be much accelerated. Gentle and quick ramming has been found most effectual.

For preserving the surface, a rough-cast plaster of coarse sand, small kunker and lime, thrown on with the hand, was found the best kind of external application. But the latest mode adopted, is to place on the edge of each layer of earth, in contact with the plank sides, rows of pieces of tile, to be imbedded three or four inches in the wall, and along with these, to a somewhat less depth in the wall, a mixture of lime, soorkhee and broken bricks. This is slightly moistened, and being rammed, similarly to the rest of the work, becomes when finished, a sort of pukka facing to the wall. This will, more readily than earthen Pisé, receive plaster, if further exterior finish is desired. For one face of one piece of casing, ten feet by two and a half, the following amount of these materials are required:—

Earth-lime,	1 maund.
Soorkhee,	20 seers.
Broken bricks and tiles,	20 „

Here is the cost of one 10 feet casing complete, at Bareilly:—

	R. A. P.
165 ft. plank, at Rs 2-8 per 100 sup. ft., including cartage,	4 2 0
8 uprights, at 4 as. each,	2 0 0
6½ seers, iron nails, at 2½ seers per rupee,	2 14 0
1 maund iron for connecting rods,	6 12 0
16 pins (¼ seer weight), at 2½ seers per rupee,	0 3 0
16 carpenters, at 8 as. each,	3 0 0
Smiths,	1 8 0
	<hr/>
Total Rupees, ..	20 7 0
5 rammers, at 3 as. each,	0 15 0
2 crowbars,	0 2 0
	<hr/>
Total Rupees, ..	1 1 0

The cost of the work at Bareilly (exclusive of the original cost of cases and tools) is as follows:—

Materials.	1 case, 10 ft. × 3 × 2½ 75 cub. feet.		4 cases, wall 10 ft. high 100 cub. ft.		per 100 cub. feet.				
	R.	A.	P.	R.	A.	P.			
EAETH.									
Carting.—2-bullock hackery, 10 or 11 mannds, } about 7 trips a day, @ 5 as., }	0	6	0	1	8	0	0	8	0
PUCKA FACING.									
Lime, 1 maund, soorkhee, 20 seers, broken } bricks, 20 ditto, }	0	2	0	0	8	0	0	2	8
Total materials, ..	0	8	0	2	0	0	0	10	8
LABOR.									
At Bareilly, the work was chiefly done by pris- oners. When laborers are employed, then— 6 men, 8 days, at 2 as. per diem (for one case),	2	4	0	9	0	0	3	0	0
Total, ..	2	2	0	11	0	0	3	10	8

It is probable that the cost of the whole apparatus may be considerably reduced.

Report on the Pisé work executed at the Etah Jail during 1867-68. By Mr. H. SPRENGER, Assist. Engineer.

The boxes in which the pisé work at the Etah Jail is being executed, consist of two wooden frames ten feet long and two and a half feet broad, made of planks, which are nailed on to stout battens. They are held together by four pairs of posts 3" x 3" which are connected above and below with tie-bars of flat iron 1½" x ¼". The tie-bars have at each end a certain number of half inch holes punched in them to receive pins for the purpose of preventing the posts from slipping off. By changing the pins, walls of any given dimension can be obtained, wedges of hard wood, with longitudinal slots, are introduced between the posts and the pins, to adjust the breadth of the boxes to a standard gauge. After the boxes are fixed and adjusted, they are secured in their position by ropes passing over them, and tied to stakes on each side. Any deflection from the vertical should be corrected at the commencement of the work, as it is impossible to alter the position of a box after it is half full. Any earth which is suitable for brickmaking will do for Pisé work, on being dug out it is passed through a screen with half inch meshes, and thrown into the boxes in even layers of six inches in depth.

Generally fresh earth contains sufficient moisture to ensure good consolidation; but if it is found that it jumps up under the rammers, it should, on being thrown into the boxes, be sprinkled with a little water out of a tin can with a rose. The watering should be as uniform as possible, as if it is applied unequally it will liquify the earth, which will commence oozing out under the rammers. Pisé work executed with too much water is worse than if done with dry earth, as, on account of the elasticity of the wet earth, the effect of the ramming is deadened, and the earth remains unconsolidated. The men should be prohibited to keep time in ramming, as it causes vibration, which is injurious to the stability of the wall. On working over a lower course, it is as well to let the lower tie-bars about four inches into the same to give the boxes a firm hold on the old work, thereby the joints become imperceptible, and the upper edge of the lower course is prevented from chipping off.

The implements used are the three different kinds of rammers shown in the drawing, the earth is first beaten down with the V-shaped rammer, and then surfaced with the one with the flat bottom. The sides of

the boxes are consolidated with the spade-shaped rammer. When commencing the Pisé work at Etah, considerable difficulty was experienced in extracting the lower tie-bars. These were, therefore, supplied with holes three inches apart throughout their whole length. A pin was inserted, against which a crow-bar with a long slot and well bent at the end was made to work. An equal pressure could thereby be exerted against the tie-bars, they were thus extracted with great facility without injuring them or the face of the wall, which was not the case formerly. A pattern of a box made of sál wood, costing Rs. 40, was received from the Etawah Jail; according to this 22 new ones were constructed. As it was, however, presumed that they would be all but thrown away on the completion of the work, which was expected to take place in less than a year, they were made of mangoe instead of sál wood, whereby the price was reduced to Rs. 22. Boxes, however, intended for constant use should decidedly be of substantial wood, as the 22 above-mentioned will barely suffice to complete the wall of the Jail at Etah, containing 1,00,000 cubic feet of Pisé masonry. If the inside of the frames are well smoothed and evened, and they are continually kept in gauge, the Pisé walling will present a very substantial and uniform appearance when finished.

The contrast of the effect of rain which fell in April and May on the Pisé walling and on common kucha masonry of the same age was very marked,—the former had hardly been affected at all, whereas the latter was very much cut up and honey-combed, and had to be *leaped* with *gober* to preserve it.

The cost of 100 cubic feet of Pisé on a wall 14 feet high and 2½ feet thick was as follows, the average lead of the earth having been 800 feet:—

	RS.	A.	P.
Digging, 1 beldar,	0	2	0
Transport of earth, 4 boys,	0	6	0
Ramming, including putting up and taking down of boxes, 6 beldars,	0	12	0
Screening and breaking of earth, 1 beldar,	0	2	0
Watering, 1 boy,	0	1	6
Superintendence, ¼ mistree,	0	1	0
Cost of box—one box being able to turn out 5,000 cubic feet Pisé work,	0	7	0
Baskets, ropes, &c.,	0	0	9
Repairs to boxes and ironworks.	0	1	9
Total, ..	2	2	0

PLAN OF PISÉ BOX

as used in the Construction of the outer wall of the Ben-Hail

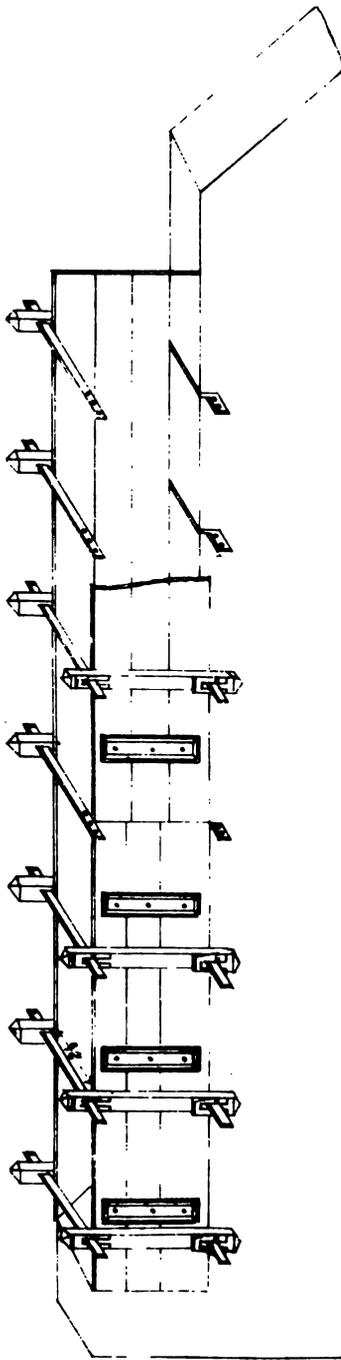

Side Elevation of Pisé Box

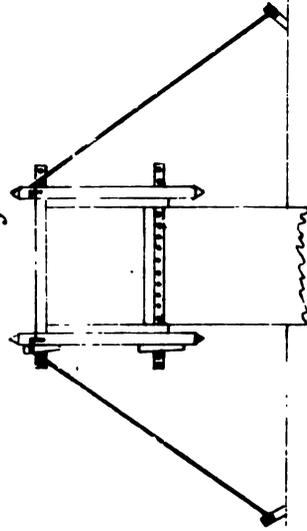

Pisé Box Frame

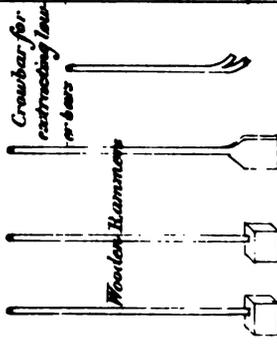
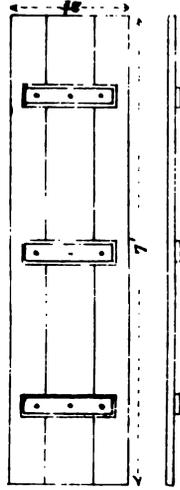

Side Elevation of Pisé Box





Note by MR. E. BATTIE, Exec. Engineer, 5th Divn. Grand Trunk Road.

The above rate, Rs 2-2-0 per 100 cubic feet, is a low one, and owing to earth for the Pisé work having been procured close to one side of the Jail. The earth procurable at Etah for the Jail enclosure wall is not first class. The work has, however, stood the test of some very heavy falls of rain. While the ordinary kucha brick masonry in the buildings suffered as usual in having the kucha plaster, and *leaping* partially washed off, the Pisé work scarcely showed any signs of having been exposed to rain. By ramming small pieces of tile on the outer surface of the Pisé work, it may be made to retain pukka plaster.

From the accompanying sketch of the boxes used, it will be seen that they could be used for constructing Béton Pisé, or any other ordinary concrete work. The use of concretes for building purposes should receive more attention, as the great and increasing difficulty in procuring bricks, together with the high rates, raises the cost of brick masonry to a very high figure; and delay caused in the construction of small detached buildings by time occupied in the manufacture of bricks is sometimes very great.

Supplementary Note by MR. E. BATTIE, Exec. Engineer, 5th Divn., Grand Trunk Road.

It requires only one day to fix and fill one Pisé box (with half the labor given above for 100 cubic feet, each case containing 50 feet). The work at Etah has generally been concluded in the following manner:—In the morning the boxes were taken down, and again put up and filled during the day; they were left during the night, so that the earth might detach itself from the sides. It is not advisable to allow a course to dry thoroughly, as the upper one will not bind well into it, but probably show a crack. If the earth is well rammed, and only the proper quantity of moisture admitted, a second course can be commenced immediately. In buildings in which Pisé work is likely to be used, this would seldom be necessary. Such works as Jail and Hawalat surrounding walls are generally of considerable extent. The Etah Jail wall is 2,700 feet in length, in which 22 cases have been used; more could have been made, and the work carried on with greater rapidity, had sufficient labor been available.



CAMP STOVE
MADE OF LIGHT SHEET-IRON.

Warranted not to smoke—can all be made from one sheet—all angles either bends or straight flap joints—carries on camel—and costs about Rs. 10.

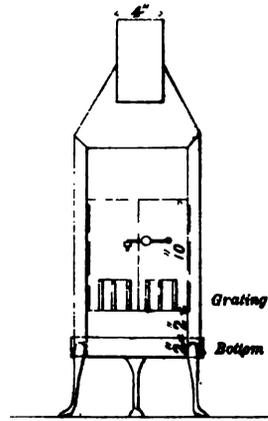

Front Elevation.

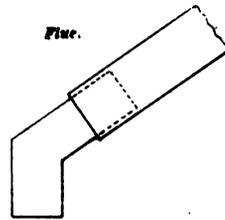

Flue.

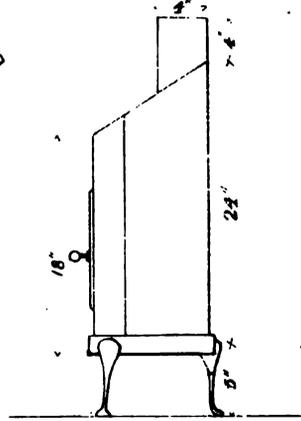

Side Elevation.

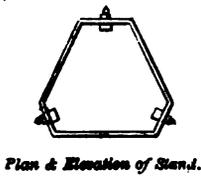

Plan & Elevation of Stand.

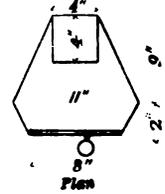

Plan

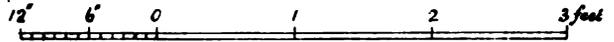

Shows Stove cut out of one sheet—no particular scale—whole lines, cuts—dotted lines, bends.

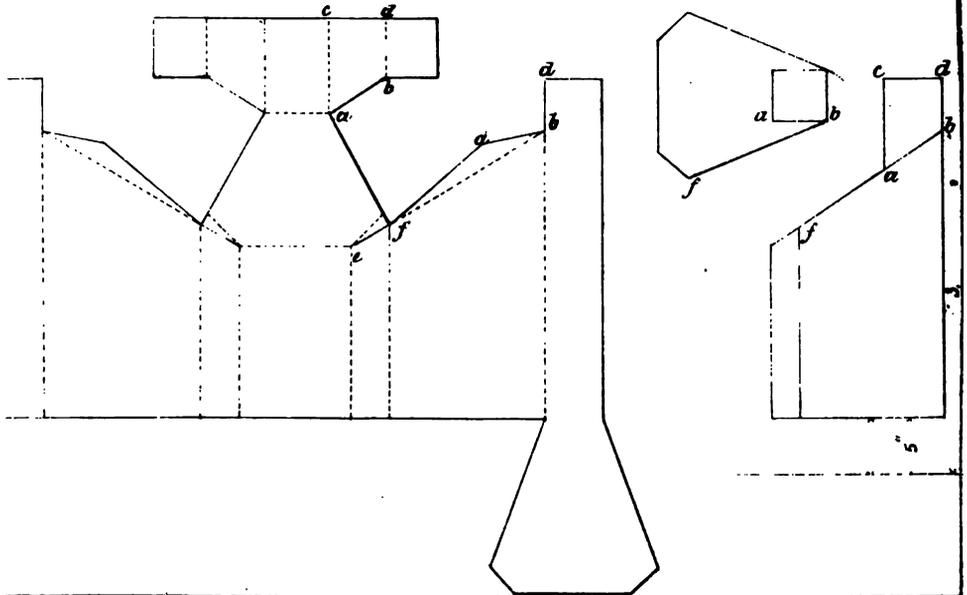

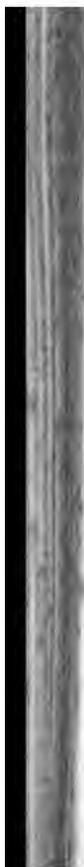

The first part of the document is a list of names and titles, including the names of the authors and the titles of their works. The text is arranged in a structured format, with names and titles separated by lines and possibly by small symbols or punctuation. The list appears to be a table of contents or a list of references, detailing the contributions of various individuals to the field of study. The text is somewhat faded and difficult to read, but the overall structure is clear and organized.

CAMP STOVE

MADE OF LIGHT SHEET-IRON.

Warranted not to smoke—can all be made from one sheet—all angles either bends or straight flap joints—carries on camel—and costs about Rs. 10.

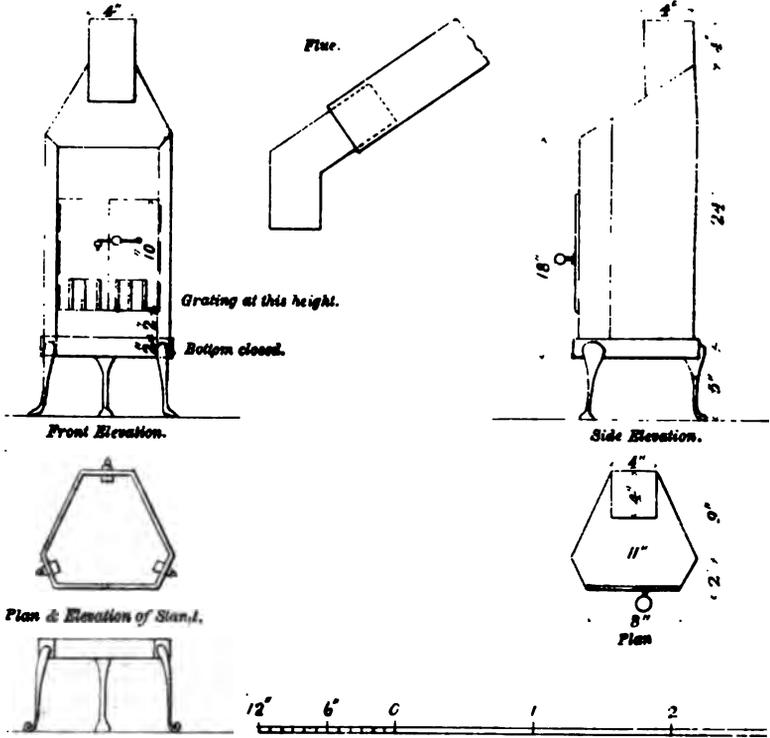

Show Stove cut out of one sheet—no particular scale—whole lines, cuts—dotted lines, bends

