

THE EISENHOWER LIBRARY

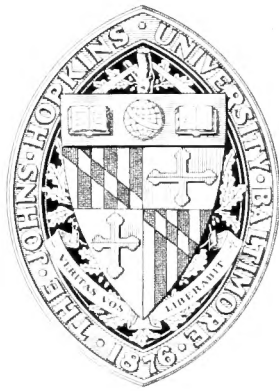

3 1151 02293 5401

11/22/54



THE LIBRARY



SMITHSONIAN INSTITUTION
INSTITUTE OF SOCIAL ANTHROPOLOGY
PUBLICATION NO. 10



NOMADS OF THE LONG BOW

THE SIRIONO OF EASTERN BOLIVIA

by

ALLAN R. HOLMBERG





SMITHSONIAN INSTITUTION
INSTITUTE OF SOCIAL ANTHROPOLOGY
PUBLICATION NO. 10

NOMADS OF THE LONG BOW

THE SIRIONO OF EASTERN BOLIVIA

by

ALLAN R. HOLMBERG

*Prepared in Cooperation with the United States Department of
State as a Project of the Interdepartmental Committee
on Scientific and Cultural Cooperation*



For sale by the Superintendent of Documents, U. S. Government Printing Office Washington 25, D. C. - - - - - Price 65 cents

LETTER OF TRANSMITTAL

SMITHSONIAN INSTITUTION,
INSTITUTE OF SOCIAL ANTHROPOLOGY,
Washington 25, D. C., June 21, 1948.

SIR: I have the honor to transmit herewith a manuscript entitled "Nomads of the Long Bow: The Siriono of Eastern Bolivia," by Allan R. Holmberg, and to recommend that it be published as Publication Number 10 of the Institute of Social Anthropology.

Very respectfully yours,

GEORGE M. FOSTER, *Director.*

DR. ALEXANDER WETMORE,
Secretary of the Smithsonian Institution.

CONTENTS

	PAGE		PAGE
Phonetic note.....	iv	Folk beliefs and science.....	46
Introduction.....	1	Numeration, mensuration, and time reckoning.....	47
Setting and people.....	4	Social and political organization.....	49
Physical type.....	8	The family.....	49
History.....	8	The extended family.....	50
Technology.....	11	The band.....	50
Fire.....	11	Kinship system.....	52
Glue manufacture.....	11	Kinship behavior.....	56
Textile industries.....	11	Social stratification.....	58
Ceramics.....	12	Chieftainship.....	59
Utensils.....	13	Law and social control.....	60
Tools.....	14	Ingroup conflict.....	61
Weapons.....	14	Warfare.....	62
Housing.....	17	The life cycle.....	63
Dress and ornament.....	19	Sex.....	63
Property.....	21	Reproduction.....	65
Exploitative activities.....	21	Childbirth.....	67
Seasonal cycle.....	21	Multiple births.....	70
Hunting.....	23	A case of twins.....	70
Fishing.....	27	Paternity.....	73
Collecting.....	27	Naming.....	74
Agriculture.....	28	Infancy.....	75
Animal husbandry.....	29	Childhood.....	77
Water and fuel.....	30	Puberty rites.....	80
Food and drink.....	30	Marriage.....	81
Diet.....	30	Adulthood.....	83
Food taboos.....	32	Old age.....	85
Preservation and storage of food.....	34	Disease and medicine.....	85
Preparation of food.....	34	Death and burial.....	87
Eating.....	36	Religion and magic.....	90
Narcotics.....	37	Religion.....	90
Drinking.....	37	Magic.....	91
Routine activities of life.....	40	Dreams.....	91
Daily round.....	40	The soul.....	91
Work and division of labor.....	41	Some problems and conclusions.....	92
Travel and transportation.....	42	Bibliography.....	100
Art, music, and dancing.....	44	Index.....	101

ILLUSTRATIONS

PLATES

(All plates at end of book)

- | | |
|---|---|
| <p>1. Siriono hut, pregnant woman, and a 14-year-old boy.</p> <p>2. Siriono chief and his wives, and Siriono boys.</p> <p>3. Method of carrying baskets by men, a boy drawing bow, bringing in firewood, and hunter with curassow.</p> <p>4. Hunters returning from forest with coatis and monkeys.</p> | <p>5. Hunter leaning on pole, and cutting up a tortoise.</p> <p>6. Cutting up and roasting monkey meat.</p> <p>7. Mother carrying baby in sling, and decorations worn by father of newborn child.</p> |
|---|---|

CHARTS

	PAGE		PAGE
1. Lineal kinship chart Siriono (male speaking)---	53	3. Affinal kinship chart Siriono (male speaking)---	56
2. Lineal kinship chart Siriono (female speaking)--	55	4. Affinal kinship chart Siriono (female speaking)--	56

MAP

	PAGE
1. Territory occupied by the Siriono in eastern Bolivia.....	5

PHONETIC NOTE

In the pronouncing and writing of native words, vowels and consonants have Spanish values. Exceptions to this are the following:

ĉ=*ch* as in *chair*.

g=*g* as in *go*.

h=*h* as in *hat*.

ĵ=*j* as in *joke*.

k=*k* as in *keep*.

N=*ng* as in *sing*.

ŝ=*sh* as in *shop*.

w=*w* as in *want*.

z=*z* as in *zone*.

Nomads of the Long Bow

The Siriono of Eastern Bolivia

By ALLAN R. HOLMBERG

INTRODUCTION

This study ¹ was carried out under the auspices of the Social Science Research Council, of which I was a predoctoral fellow in 1940-41. It had its origin in 1939, when I was associated with the Cross-Cultural Survey at the Institute of Human Relations, Yale University. While studying there, I was privileged to get considerable exposure to the cross-disciplinary approach to the problems of culture and behavior which was, and still is, being emphasized at the Institute, especially by Drs. Murdock, Hull, Dollard, Miller, Ford, and Whiting.

As I continued my anthropological studies, it became more and more apparent to me, as to others, that a science of culture and behavior was most apt to arise from the application of techniques, methods, and approaches of several scientific disciplines concerned with human behavior—particularly social anthropology, sociology, psychology, and psychoanalysis—to specific problems. Consequently, in casting around for a subject on which to carry out field work, I began to search for one that would be especially adaptable to cross-disciplinary treatment.

While studying at the Institute of Human Relations, I became keenly aware of the significant role played by such basic drives as hunger, thirst, pain, and sex, in forming, instilling, and changing habits. Because of the difficulty of studying human behavior under laboratory conditions, our knowledge about the processes of learning has been derived largely from experimental studies of animals. However, the procedure, successfully employed in psychological experimentation, of depriving animals of food suggested that it might

be possible to gain further insight into the relationship between the principles of learning and cultural forms and processes by studying a group of perennially hungry human beings. It was logical to assume that where the conditions of a sparse and insecure food supply exist in human society the frustrations and anxieties centering around the drive of hunger should have significant repercussions on behavior and on cultural forms themselves. Hence, I took as my general problem the investigation of the relation between the economic aspect and other aspects of culture in a society functioning under conditions of a sparse and insecure food supply. More specifically, the problem resolved itself into determining, if possible, the effect of a more or less constant frustration of the hunger drive on such cultural forms as diet, food taboos, eating habits, dreams, antagonisms, magic, religion, and sex relations, and upon such cultural processes as integration, mobility, socialization, education, and change.

In our own society there are many individuals who suffer from lack of food, but one rarely finds hunger as a group phenomenon. For this reason a primitive society, the Siriono of eastern Bolivia, was chosen for study. The Siriono were selected for several reasons. In the first place, they were reported to be seminomadic and to suffer from lack of food. In the second place, they were known to be a functioning society. In the third place, the conditions for study among them seemed favorable, since it was possible to make contact with the primitive bands roaming in the forest through an Indian school which had been established by the Bolivian Government in 1937 for those Siriono who had come out of the forest and abandoned aboriginal life.

¹ The data in slightly different form were presented to the Graduate School of Yale University in partial fulfillment for the degree of doctor of philosophy.

I left for Bolivia on September 28, 1940, and arrived in the field on November 28, 1940. Between November 28, 1940, and May 17, 1941, I worked with informants of various bands of Siriono who had been gathered together in a Bolivian Government Indian school at Casarabe, a kind of mixed village of Indians and Bolivians, situated about 40 miles east of Trinidad, capital of the Department of the Beni. At the time of my stay this so-called school had a population of about 325 Indians.

Following my residence in Casarabe, where I became grounded in the Indian language and those aspects of the aboriginal culture that still persisted there, I left in May 1941, to join a band of about 60 Siriono who were living under somewhat more primitive conditions near the Rio Blanco on a cocao plantation, called Chiquiguani, which was at that time a kind of branch of the above-mentioned school. Upon arriving at Chiquiguani, however, I found that as a result of altercations with the Bolivians, the Indians had dispersed into the forest, and so I encountered no people with whom to work. Consequently, I returned to a ranch near the village of El Carmen. There I was fortunate in meeting an American cattle rancher, Frederick Park Richards, since deceased, who had resided in the area for many years and who had a number of Siriono living on his farm and cattle ranch. Through him I was presented to a Bolivian, Luis Silva Sánchez, a first-rate bushman and explorer for the aforementioned school, who offered to be my companion and who stayed with me during most of the time that I lived and wandered with the Siriono. In company with Silva I set out in search of the Indians who had dispersed into the forest. After about 10 days they were located, and they agreed to settle on the banks of the Rio Blanco, about 2 or 3 days' journey up the river by canoe from the village of El Carmen, at a place which we founded and named Tibaera, the Indian word for assaf palm, the site being so designated because of the abundance of this tree found there. I spent from July 15 to August 28, 1941, at Tibaera, continuing my general cultural and linguistic studies, but under what I regarded as unsatisfactory conditions, since I had previously laid my plans and devoted my energies to acquiring techniques for observing a group of Siriono who had had little or no previous contact. Conse-

quently, I suggested to Silva that we go in search of other Indians. Finally, on August 28, 1941, I set out from Tibaera, in company with Silva and parts of two extended families of Indians (21 people in all), traveling east and south through the raw bush in the general direction of the Franciscan Missions of Guarayos, where we were told by the Indians that we might locate another band who had had little or no previous contact. After 8 days of rough travel, much of which involved passing through swamps and through an area which had long been abandoned by the Siriono, we joyously arrived at a section of high ground containing relatively recent remains of a Siriono camp site. My Indian companions told me that this site had been occupied by a small number of Indians who had come there in quest of calabashes about three "moons" earlier.

Inspired by the hope of soon locating a primitive band, we silenced our guns and lived by hunting with the bow and arrow so as not to frighten any Indians that might be within earshot of a gun. We followed the rude trails which had been made by the Indians about 3 months earlier, and after passing many abandoned huts, each one newer than the last, we finally arrived at midday on the eleventh day of march just outside of a village. On the advice of our Indian companions, Silva and I removed most of our clothes, so as not to be too conspicuous in the otherwise naked party—I at least had quite a tan—and leaving behind our guns and all supplies except a couple of baskets of roast peccary meat, which we were saving as a peace gesture, we sandwiched ourselves in between our Indian guides and made a hasty entrance into the communal hut. The occupants, who were enjoying a midday siesta, were so taken by surprise that we were able to start talking to them in their own language before they could grasp their weapons or flee. Moreover, as their interest almost immediately settled on the baskets of peccary meat, we felt secure within a few moments' time and sent back for the rest of our supplies.

Once having established contact with such a group, I had intended to settle down or wander with them for several months, or until I could complete my studies. I was forced, however, to abandon this plan when, after being with them for a day or two, I came down with an infection in my eyes of such gravity that I was almost blinded. Fearing that this infection would spread to a point

that might cause the loss of my sight, and since I carried no medicines with which to heal it, I decided to set out for the Franciscan Missions of the Guarayos, about 8 days' distance on foot, the nearest point at which aid could be obtained. Before leaving, however, I consulted with the chief of this new group (his name was Añiba-eóko or Long-arm) and told him that I planned to return and study the manner of life of his people. In the meantime, the Indians in our original party, knowing of my plan, had already convinced the chief and other members of his band to return with them to the Rio Blanco and settle down for a while at Tibaera, a plan which suited me perfectly. Consequently, in the company of four Indians of this new band and Silva, I traveled on foot to Yaguarú, Guarayos. After about 2 weeks of fine treatment at the hands of the civilian administrator, Don Francisco Materna, and the equally hospitable Franciscan fathers and nuns, I was able to rejoin the band, and we slowly returned to Tibaera, arriving there on October 11, 1941.

Besides what studies I was able to make of this band while roaming with them during part of September and October, 1941, I continued to live with them at Tibaera, except for occasional periods of 10 days' or 2 weeks' absence for purposes of curing myself of one tropical malady or another or of refreshing my mental state, until March 1942, when my studies were terminated by news that the United States had become involved in war 3 months previously.

As can be readily inferred from the account given above of my contacts with the Siriono, they were studied under three different conditions: first, for about 4 months, while they were living at Casarabe under conditions of acculturation and forced labor; second, for about 2 months, while they were wandering under aboriginal conditions in the forest; finally, for about 6 months, while they were living at Tibaera, where aboriginal conditions had not appreciably changed except for the introduction of more agriculture and some iron tools. During the course of my work, I made a complete ethnological survey of the culture, only part of which can be published here, although my attention was focused primarily on the problem of the sparse and insecure food supply and its relation to the culture. As my knowledge of the language and culture increased, I was constantly

formulating, testing, and reformulating hypotheses with respect to this problem.

Since Siriono society is a functioning one, three fundamental methods of gathering field data were employed: (1) the use of informants, (2) the recording of observations, and (3) the conducting of experiments. The first two methods were followed throughout the course of the work. Experiments, such as the introduction of food plants and animals, were performed during the latter part of the study, although the extensive use of this method was limited by the termination of the research.

The application of the above field methods was facilitated by the use of various techniques of which the following were the principal ones: (1) the use of the language of the people studied and (2) the participation of the ethnographer in the cultural life of the tribe.

When possible, data were recorded on the spot in an ethnographic journal, which was supplemented by a record of personal experiences while in the field. As the group was small, everyone was used as an informant, and since most of the activities of the Siriono center in but one hut, data on the behavior patterns of almost everyone could be recorded. No paid informants were used, although gifts such as bush knives and beads were given. No Siriono was a willing informant; little information was volunteered, and some was consciously withheld. Had it not been for the fact that I possessed a shotgun and medicines, life with the Indians would have been impossible. By contributing to the food supply and curing the sick, I became enough of an asset to them to be tolerated for the period of my residence.

At the time of leaving the field (I had not finished my studies) I did not feel satisfied that I had gained a profound insight into Siriono culture. True, I had studied the language to the extent that I could carry on a fairly lively conversation with the Indians, but the time spent in satisfying my own basic needs—acquiring enough food to eat, avoiding the omnipresent insect pests, trying to keep a fresh shift of clothes, reducing those mental anxieties that accompany solitude in a hostile world, and obtaining sufficient rest in a fatiguing climate where one is active most of the day—often physically prevented me from keeping as full a record of native life as I might have kept had I been observing more sedentary informants

under less trying conditions. However, if I have contributed something to an understanding of these elusive but rapidly disappearing Indians, I shall feel more than satisfied.

This study would have been impossible without the help of many friends and various institutions. I am deeply indebted to the Social Science Research Council for providing the funds to carry out the field work; to Yale University (through the efforts of Dr. Cornelius Osgood) for granting me a Sterling Fellowship to write up the field data; and to the Smithsonian Institution for publication of the manuscript.

To my teachers at Yale University I owe a profound debt of gratitude, especially to Dr. G. P. Murdock, who has been a friendly adviser since the beginning of the study. Dr. Murdock spent many hours patiently reading, criticizing, and editing much of the original manuscript. While living with the Siriono, I also had the benefit of his counsel, together with that of the late Dr. Bronislaw Malinowski, Dr. Clark Hull, and Dr. John Dollard, all of whom formed an advisory committee at Yale. These gentlemen were largely responsible for developing my interest in certain problems of this research, and all of them sent me many stimulating letters of advice and criticism while I was in the field. None of them is responsible for any of its defects.

I wish to express my deepest appreciation to Dr. Alfred Métraux. It was he who was largely responsible for crystallizing my interest in the South American Indian and for my selection of the Siriono among whom to work. Dr. Métraux took a keen interest in this study from its inception and gave me constant encouragement while I was in the field. An invaluable service was also rendered by Dr. Wendell C. Bennett, who acted in an advisory capacity when I started to write up my field notes, and by Dr. Clellan S.

Ford and Dr. John W. M. Whiting, who made many helpful suggestions and criticisms while I was preparing the manuscript. To my wife, Laura, goes the credit for patiently typing and retyping the manuscript.

While I was in Bolivia, many people helped me in the pursuit of my studies. I wish to express my thanks especially to Dr. Gustav Otero, of La Paz, then Minister of Education, for providing me with a letter of introduction to the Director of the Núcleo Indigenal de Casarabe; to Don Carlos Loayza Beltrán, then Director of the Núcleo, and Horacio Salas, then Secretary of the Núcleo, for several months of friendly hospitality; to Senator Napoleón Solares A., of La Paz, and Don Adolfo Leigue, of Trinidad, for comfortably sheltering me in the Casa Suárez in Trinidad, Beni.

My life with the Indians at Tibaera was made possible through the valiant cooperation of Don Luis Silva Sánchez, of Santa Cruz de la Sierra. Nothing I can say will express the gratitude I feel for this fearless Cruzeño who accompanied me for more than 6 months in the field under the most trying conditions. Had it not been for Silva, in fact, my life with the Siriono under aboriginal conditions would have been unbearable.

I am deeply grateful to the late Frederick Park Richards of El Carmen for his bounteous hospitality and for generously providing me with the food and the mobility without which it would have been impossible to carry out my studies. I also wish to express my thanks to Don René Rousseau of Baures and Dr. and Mrs. Lothar Hepner, then of Magdalena, for many days of friendly hospitality and cordial companionship.

Finally, I should like to express my appreciation to the Siriono who, for the first time in their history, tolerated a naive but inquisitive anthropologist on his first extended stay in the field.

SETTING AND PEOPLE

The Siriono are a group of seminomadic aborigines inhabiting an extensive tropical forest area, of about 200 miles square, between latitudes 13° and 17° S. and longitudes 63° and 65° W., in northern and eastern Bolivia. The name applied to these Indians is not of their own origin.² They

² The origin of the name Siriono is unknown. Wegner (1934 b) has suggested that it came from the Siriono word *siri*, meaning "chonta palm," but there is no such suffix as *ono* in the Siriono language and the Indians are unacquainted with the name applied to them.

refer to themselves simply as *mbía* or "people." But as they have been called Siriono since first contact, and have been thus designated in the literature, I shall adopt the term.

The area of Bolivia inhabited by the Siriono is situated in the Departments of the Beni and Santa Cruz. It is roughly bounded on the north by the island forests, lying just south of the villages of Magdalena, Huacaraje, and Baures; on

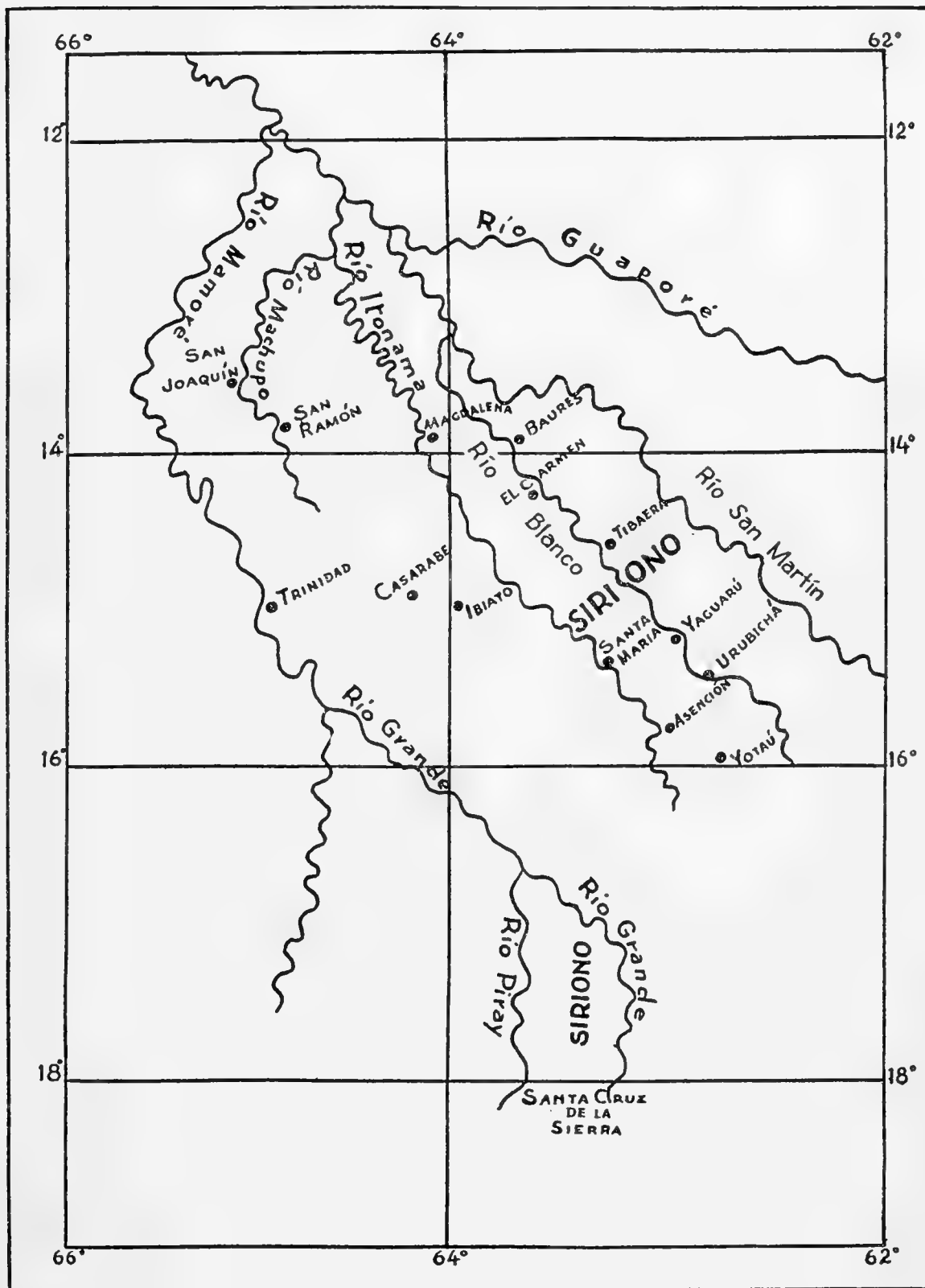

MAP 1.—Territory occupied by the Siriono in eastern Bolivia.

the south, by the Franciscan Missions of Guarayos; on the east, by the Rio San Martín; and on the west, by the Rio Grande and Rio Mamoré. Within this extensive area the Siriono have lived and wandered in isolated pockets since the first European contact with them in 1693.

Until the 1930's, a great many Siriono were living in the island forests of the Mojós plains east of Trinidad and between the Rio Grande and Rio Piráy, but now most of these have become acculturated and are living under conditions of almost forced labor on cattle ranches, farms, schools, and missions near Trinidad, Magdalena, Baures, El Carmen, Guarayos, and Santa Cruz. Actually, almost the only unacculturated Siriono extant today are those occupying the forest country southeast of the village of El Carmen. Here, east of the banks of the upper Rio Blanco, is located a range of hills, locally known as the Cerro Blanco, near which wander a few groups of Siriono, who have as yet been unmolested by white contact. There may also still be some living between the Rio Grande and Rio Piráy, but these have not been seen by me.

The region occupied by the Siriono is characterized by a tropical climate with two seasons, the wet and the dry. The former lasts from November to May; the latter from May to November. The annual mean temperature (no records available) runs around 73° F., with extremes of 50° F. during the cold south winds from Tierra del Fuego and 110° F. during the heat of the average day. During the rainy season the climate is very hot and moist, with rains on the average of every other day; during the dry season the extreme heat of the day is tempered by cooler nights and occasional cold wind storms from the south. These "sures," as they are called by the Spanish-speaking natives of the region, are usually accompanied by rain and a very sudden drop in temperature. They generally last about 4 days and occur at average intervals of 15 days during April, May, and June. The prevailing winds, however, are from the north. The average rainfall is about 100 inches per year.

Geographically speaking, the Siriono country is situated in the eastern part of the vast plain, partly forested and partly pampa, lying between the Andes on the west and the Mato Grosso Plateau on the east. From south to north, this plain extends from the hill country north of the Gran Chaco to the low unexplored hills of Brazil

which lie just north of the Rio Guaporé. Within this area, from the Rio Blanco west to the Rio Mamoré, are located the extensive llanos of Mojós dotted with the island forests once occupied by the Siriono. East of the Rio Blanco, however, between the Rio Guaporé on the north and the Franciscan Missions of Guarayos on the south, is a vast and dense forest plain which runs for hundreds of miles, and within which the few extant Siriono still wander today. This plain contains occasional low ranges of hills, which are part of the same chain that runs into Brazil on the north and into the Chiquitos region of Bolivia on the south.

Except for the above-mentioned hills, the area generally is flat and only about 500 feet above sea level. Both the pampas and the forests are characterized by *alturas*—high lands that do not flood during the rainy season—and *bajuras*—low lands that do flood in the rainy season. The *alturas* are characterized by a resistant capping of partially decomposed lava, containing a top soil of coarse sand with occasional outcroppings of igneous rock. In elevation they lie some 75 feet above the *bajuras*, which are made up of a heavy clayey top soil and which are flooded during most of the rainy season. The *alturas* of the forest are considered to be the richest agricultural lands, while the *bajuras* of the pampa, since water stands in many of them the year around, are suitable for little more than grazing.

The outstanding watershed features of the region are its numerous lakes and rivers. Of the former there are some 20 large ones in the Siriono country known to me, but which have not been named as yet. Around all of these lakes are extensive flood lands, and stemming from each are brooks or *arroyos* which drain into other lakes or into the principal rivers of the area, the Rio San Martín, the Rio San Joaquín, the Rio Negro, the Rio Blanco, Rio Itonama (San Miguel or San Pablo), and the Rio Machupo. All of these rivers flow into the Guaporé (Itenez) before it joins the Mamoré (Madeira) in its route to the Amazon. The southwestern part of the area is drained by the Rio Piráy and Rio Grande, which also flow into the Mamoré. Although the rivers are numerous and of good size, the area in general is poorly drained; from the air during the rainy season it has somewhat the appearance of a huge swamp within which there are islands of high

ground. All of the rivers follow very capricious courses and are of great age.

The environment, so far as is known, contains no mineral deposits of note. Gold has been reported from the region of the Cerro Blanco—which might be expected in view of the fact that gold is mined in the Chiquitos region to the south and has been mined in the Cerro San Simón to the north—but no deposits of significance have ever been worked. Stone is unknown in Mojos, although a poor grade of igneous rock is found along the Rio Itenez and the Rio Blanco. In the entire region there is no salt, coal, or petroleum.

Present in the area, but not in the abundance that most people are wont to imagine they exist in tropical forests, are the most common types of Amazon Valley fauna. The principal mammals are the tapir, jaguar, puma, capybara, deer, peccary, paca, coati, agouti, monkey, armadillo, anteater, opossum, otter, and squirrel. Bats are a perennial pest.

Land and waterfowl are numerous. The king of these birds is the harpy eagle. Likewise present, and in greater numbers, are the king vulture and the black vulture, which are almost always seen high in the sky gliding like planes in search of carrion. Game fowl are also plentiful, especially the curassow, guan, wild duck, macaw, toucan, partridge, egret, cormorant, hawk, pelican, plover, kingfisher, trumpeter, spoonbill, and parrot. On the pampa one also frequently encounters the South American ostrich and varieties of ibis.

Of the reptiles, alligators and tortoises are plentiful. Occasionally one sees a *tegu* or an iguana. More rarely encountered are snakes, including the anaconda, the fer-de-lance, the bushmaster, the rattler, and coral snakes.

The rivers and lakes of the area are well stocked with fish. Among the principal kinds are the palometa, the pacú, the parapatinga, the tucunaré, several kinds of catfish, and the sting ray. Also present but rarely caught is the pirarucú, the largest bony fresh-water fish in the world. Not infrequently seen sporting in the lakes and rivers are schools of fresh-water porpoises, which may come so close as to upset one's canoe when traveling by water. There are few shellfish and mollusks in these inland waters.

Only one who has traveled in the region can appreciate the myriad forms of insect life that

harass the inhabitants. Since a great part of the country is swamp for at least 6 months of the year, mosquitoes of all kinds (and of which the area is never free) can breed unhampered, and, as night falls, these insects, together with gnats and moths, descend upon one by the thousands. During the day, when these pests retire to the swamps and the depths of the forest, their place is taken by innumerable varieties of deer flies and stinging wasps. When traveling by water during the day, one is also perennially pestered by tiny flies which settle on the uncovered parts of one's body by the hundreds and leave minute welts of blood where they sting.

No less molesting are the ants, most of which are stinging varieties. The traveler in the forest soon learns what kinds to avoid. Especially unpleasant are those which inhabit the tree called palo santo, the sting of a few of which will leave one with a fever, and the *tucondera*, an ant about an inch in length whose bite causes partial paralysis for an hour or two.

In addition to the ants, mosquitoes, and flies, there are scorpions and spiders whose bites may also cause partial paralysis and for whose presence one must be continually on the lookout, and sweat bees, which drive the perspiring traveler to a fury in trying to escape them. Some mention should also be made of the wood ticks, which range in size from a pin point to a fingernail. During the dry season as many as a hundred may drop from a disturbed leaf on to a person as he passes by. One of the most common pastimes of the Indian children, in fact, is picking off wood ticks from returning hunters.

The flora, like the fauna, is typical of the Amazon River Valley. The forests may be characterized especially by an abundance of palms, among which the principal varieties are the motacú, assaí, chonta, totaí, samuque, and cusi. All of these palms yield an edible heart and nuts or fruits, which constitute an important part of the diet of the Indians. No less important in this respect are other fruit trees, particularly the pacobilla, the coquino, the pacáy, and the aguaf.

Of the trees not producing fruit few are used by the Siriono. An exception is the ambaibo, the fiber of whose bark is twined into string out of which the hammocks and bow strings are made. Abundant in the area, however, are such common Amazon Valley trees as mahogany, condurú, cedar,

bamboo, massaranduba, itaúba, mapájo, bibosi, palo santo, ochoó, and rubber. Along some of the rivers there are also stands of chuchio (reed), from which the Siriono make their arrow shafts.

The pampa chiefly supports a grassy vegetation that is able to withstand extremes of wetness and dryness. Rows of palm are sometimes encountered on the pampa, but more often than not these plains are barren of trees as far as the eye can see.

PHYSICAL TYPE

Because of the lack of accurate instruments while I was in the field, I was unable to record exact physical measurements of the Siriono. Roughly speaking, however, it can be said that the men average about 5 feet 4 inches in height; the women, about 5 feet 2 inches. The cephalic index falls within the range of brachycephaly to mesocephaly; the nasal index is definitely platyrhine.

Except in the cases of obvious crosses (the area has not lacked travelers, some of whom may have left their marks) skin color is very dark—almost negroid. The same may be said for the hair, which is not only jet black, but coarse and straight as well. The eyes are a deep brown in color; the Mongolian fold is marked.

Pilosity is not pronounced but is greater than in most Indian groups. Some of the men have well developed beards, and all have a full growth of pubic hair, with a lesser growth of axillary hair. Women show marked differences with respect to pubic hair; some have heavy growths while others have none at all.

Head hair is extremely thick on both sexes and grows to a very low line on the forehead. Children are always born with a full head of thick hair, and

the extension of the hair line to a point very low on the forehead is also very striking at birth.

Except for a very poor development of the lower legs, the Siriono are well-constructed physical specimens. Ontogenetically, they seem to fall within the normal human range. The men demonstrate a marked growth of the shoulder muscles as a result of pulling the bow; the women tend strongly to distended abdomens and pendant breasts, especially after childbirth. The protruding stomachs frequently found in children are almost always due to hookworm.

As a result of the habit of picking up objects between the big and the second toe, most men and women possess well developed prehensile toes. One rarely sees an Indian retrieve anything from the ground with his hands that he is able to pick up with his feet.

An unusual physical characteristic among the Siriono, one which might almost be called a mutation, is the small hereditary marks which characterize the backs of their ears. These marks or depressions in the skin, which appear at birth, look as if a little piece of flesh had been cut out here and there. If a Siriono were in doubt as to whether he were talking to one of his countrymen he would need only to look at the backs of his ears to identify him. These marks do not appear in any of the crosses I have seen. Most of the Indians with whom I talked, however, were only vaguely conscious of this characteristic and had no explanation for it.

Another unusual feature of the Siriono is the high incidence of clubfootedness. This trait appears in about 15 percent of the population. At some time in Siriono history this recessive character has appeared and persisted because of the highly inbred character of the group.

HISTORY

The Siriono are an anomaly in eastern Bolivia. Widely scattered in isolated pockets of forest land, with a culture strikingly backward in contrast to that of their neighbors, they are probably a remnant of an ancient population that was exterminated, absorbed, or engulfed by more civilized invaders. Their language, however, is Tupian, elsewhere spoken by tribes of a more complex culture, but here represented only by themselves and the Guarayu-Pauserna, whose dialects are

closely related. Traditions of friendship suggest that these peoples may once have been linked by a now obscure bond.

With the rest of their neighbors the Siriono show few affinities, cultural or linguistic. To the north and west live the warlike Moré, with whom they have had no contact. To the west are settled the Mojo, with whom they likewise have had little intercourse. Only in recent times have they associated with the Bauré and Itonama, who reside to

the north and who have been acculturated since the days of the Jesuits. Whenever possible they avoid clashes with the so-called Yanaigua, who wander to the south and who occasionally raid them, killing their men and stealing their women and children.

It is probable that the Siriono are of Guarani origin, that they have gradually been pushed northward into the sparsely inhabited forests they now occupy, and that in the course of their migrations they have lost much of their original culture. There is no evidence, cultural or linguistic, however, to support the theory held by Nordenskiöld (1911, pp. 16-17) that they represent a substratum of culture which once existed widely in the area they now occupy. The intangible aspects of Siriono history still await reconstruction.

Our previous knowledge of the Siriono, which is very scanty, dates from 1693, when they were first seen for a few days by Father Cyprian Barrace.³ At that time the Siriono were occupying the deep forests in the southern part of the same region which they inhabit today. After first contact, and before their expulsion in 1767, the Jesuits probably made several attempts to missionize them. At any rate, in 1765 a few Siriono were coaxed into the mission of Buena Vista and were later transferred to the mission of Santa Rosa on the Rio Guaporé. So far as we know, no other attempt was made to missionize them until comparatively recent times. Of these endeavors most have failed, not so much because of warlikeness, since this character has been falsely attributed to the Siriono, but because of their sensitivity to maltreatment and their adherence to nomadic life.

In 1927, decimated by smallpox and influenza, a small group of Siriono was settled at the Franciscan Mission of Santa María near the Rio San Miguel. This venture did not result in success. In 1941 I met many Indians in the forests between Tibaera and Yaguarú who had formerly been living in Santa María but who had reverted to a nomadic existence because of what they regarded as unsatisfactory conditions of life at the mission.

³ All that is recorded of Father Barrace's contact with the Siriono is the following: "It was not long before the holy man discovered another nation. After traveling some days he found himself amidst a people called the *Cirionians*. The instant these barbarians perceived the Father, they took up their arrows and prepared to shoot both at him and at the converts in his company, but Father Cyprian advanced up to them with so kind an aspect that their arrows dropped from their hands. He made some stay with them; and, by visiting their various settlements, discovered another nation called the *Guarayans*" (Lettres édifiantes . . . , 1781, vol. 8, p. 105).

In 1935 American evangelists founded a mission for the Siriono at the site of an old Mojo mound called Ibiato, some 60 miles east of Trinidad. By 1940 this mission had a population of about 60 Indians, but it, also, could not be called a successful undertaking, because of lack of funds and trained personnel. The same may be said for the Bolivian Government Indian School established at Casarabe—40 miles east of Trinidad—in 1937. However noble in its purpose, the function of this school ultimately resulted in the personal exploitation of the Indians by the staff, so that, through maltreatment, disease, and death, the number of Siriono was reduced from more than 300 in 1940 to less than 150 in 1945.

Of the remaining Siriono who have abandoned aboriginal life, a great many are living today under *patrones* on cattle ranches and farms along the Rio Blanco, Rio Grande, Rio Mamoré, and Rio San Miguel; others, who were captured as children in the forests, are now acting as servants in the villages of Magdalena, El Carmen, Huacaraje, and Baures. As to the distribution of the Siriono south and southwest of Guarayos, I have no information because I never visited this area and the literature tells us nothing. However, the total population of the Siriono today is probably about two thousand.

Alcide d'Orbigny, the great French scientist and explorer, was the first writer of any importance to mention the Siriono. In 1825 he had an opportunity to study a few captured Siriono at Bibosi, a mission north of Santa Cruz de la Sierra. Since D'Orbigny's remarks on the Siriono were the first of any significance ever to be published, I quote them *in extenso*:

Less numerous than the Guarayos, the Siriono live in the heart of dark forests which separate the Rio Grande from the Rio Piráy, between Santa Cruz de la Sierra and the Province of Moxos; from 17° to 18° south latitude and about 68° longitude west of Paris. The Siriono inhabit a large area although, according to many captives from this tribe whom we have seen at the mission of Bibosi, near Santa Cruz, their number hardly reaches 1,000 individuals.

No historian has spoken of them; their name appears only in some old Jesuit letters. According to the information we obtained in the country, the Siriono are perhaps the remains of the ancient Chiriguano, having since the conquest always inhabited the same forests. Attacked by the Inca Yupanqui about the fifteenth century, they were forced at the beginning of the sixteenth century to flee from the Guaranis of Paraguay who captured their settlements and, according to historians, annihilated them. Be

that as it may, it is possible that the Siriono, well before the Chiriguano, had come from the southeast and had migrated into areas far distant from the cradle of the Guarani nation.

The Siriono live under the same conditions as the Guarayos and have about the same color, stature, and fine proportions, judging from the few we have seen. In general, their features are the same, but they have a more savage appearance, a fearful and cold expression which is never encountered among the Guarayos. Since they have the custom of depilating their hair we cannot say whether they have as bushy a beard as the Guarayos.

We have been assured that their language is Guarani, but corrupted to the extent that they cannot understand the Chiriguano perfectly. As to their personality, it differs essentially from that of the Guarayos; they are so savage and hold so strongly to their primitive independence that they have never wanted to have contact with Christians. No one has been able to approach them unarmed. Their forebears were gentle and affable, but these are less communicative. They live in scattered tribes which wander deep into the most impenetrable forests and live only by hunting. They build rude huts formed of boughs and know no other comforts of life; everything indicates that they live in the most savage state. They have no other industry than the making of weapons. These consist of bows eight feet long and arrows even longer, which they most often use seated, both the feet and hands being employed to shoot with great force; thus they are obliged to hunt only big game. Both sexes go entirely nude, with no clothing to burden them. They do not paint their bodies and wear no ornaments. On their trips they do not use canoes. If they have a river to cross they cut liana which they attach to a tree or to stakes placed for that purpose on the banks of the river. They wind the liana around tree trunks resting in the water, thus forming a kind of bridge which the women cling to in crossing with their children. Whenever they get the opportunity they attack the canoes of the Moxos and kill the rowers to obtain axes or other tools. This is all we have learned about this tribe, without doubt the most savage of the nation [D'Orbigny, 1839, trans., pp. 341-344].

José Cardus was the next writer of any significance to deal with the Siriono. In his book on the Franciscan Missions of eastern Bolivia (Cardus, 1886, pp. 279-284) he devoted about 5 pages to a description of the condition and culture of the Siriono in the latter part of the nineteenth century. Following Cardus, Nordenskiöld (1911, pp. 16-17) interviewed two Siriono on his 1908-9 expedition to eastern Bolivia, and on the strength of this published a 2-page article about them which, however, contains very scanty data. In 1910 Theodor Herzog (1910, pp. 136-138, 194-200) published a short account of the geography of the area which also embodies a few notes on the Indians. In 1928 Arthur Radwan (1929, pp.

291-296) wrote a brief description of Siriono culture which deals primarily with their contacts with the Franciscan fathers at Santa María.

Some years ago, considerable stir was caused in the anthropological world by the publication of a series of articles and books by Richard Wegner (1928, pp. 369-384; 1931; 1932, pp. 321-340; 1934 b, pp. 2-34) on a month's journey to the Siriono country—to the Siriono between the Rio Piráy and Rio Grande and to those of the Mission of Santa María. In his various articles and books Wegner claimed to have discovered a primitive group of Siriono which he called Quruñgu'a, who possessed no language but whistling. Although this statement is patently absurd—I, too, have been with groups of Siriono who were uncommunicative for long periods of time—it should be pointed out that Wegner's observations on the material culture, although not outstanding, are fairly accurate. However, his statements about language (or its lack), group classification, religion, and other subjects do not check with my findings, nor with those of the Franciscan monk, Anselm Schermair (1934, pp. 519-521), who has written a brief article refuting the claims made by Wegner. My own data substantially agree with those of Padre Schermair, in so far as he has published them. For many years this Franciscan father has been collecting a vocabulary of the Siriono language, but his works have never been published. They will be awaited with great interest.

In 1937 Stig Rydén spent 3 weeks collecting ethnological specimens and interviewing Indians at Casarabe. His results have been recently published (Rydén, 1941). Although the descriptions of his material collections are accurate enough, Rydén's statements about the non-material aspects of culture are mostly inaccurate because he was probably deceived by staff members of the school at Casarabe into recording false information about the Indians. Moreover, lacking adequate primary data, Rydén padded his work with irrelevant speculations and comparisons which are largely meaningless for the reconstruction of Siriono history.

Finally, it should be mentioned that most of the extant data on the Siriono were admirably summed up by Alfred Métraux in 1942 (Métraux, 1942, pp. 110-114).

TECHNOLOGY

Technologically speaking, the Siriono can be classified with the most culturally backward peoples of the world. They subsist with a bare minimum of material apparatus. Being semi-nomadic, they do not burden themselves with material objects that might hamper mobility. In fact, apart from the hammocks they sleep in and the weapons and tools they hunt and gather with, they rarely carry anything with them. What few other material objects they make and use are generally hastily fashioned at the site of occupancy. A brief account of the principal technological processes and manufactured articles, with their uses, follows.

FIRE

Fire making is a lost art among the Siriono. I was told by my older informants that fire (*táta*) used to be made by twirling a stick between the hands, but not once did I see it generated in this fashion. Fire is carried from camp to camp in a brand consisting of a spadix of a palm. This spongelike wood holds fire for long periods of time. When the band is traveling, at least one woman from every extended family carries fire along. I have even seen women swimming rivers with a firebrand, holding it above the water in one hand while paddling with the other.

In the hut every family has its own fire on the ground by the side of the hammock. Dried leaves of motacú palm are used to bring a fire to a blaze. Any dried or rotten wood serves as firewood (*ndéa*). The logs are placed on the ground like the spokes of a wheel, the fire being made in the part corresponding to the hub. As the ends of the logs burn down they are pushed inward. Cooking pots are placed directly on the logs. No hearths are used.

GLUE MANUFACTURE

The only native "chemical" industry is the making of glue from beeswax (*iríti*). This product is used extensively in arrow making. The crude beeswax collected from the hive is put in a pot, mixed with water, and brought to a boil. While it is cooking, the dirt and other impurities are removed. The wax is then cooled and coagulated into balls about the size of a baseball.

When desired for use, the wax is heated and smeared over the parts to be glued. It is generally but not always the men who prepare and refine beeswax.

TEXTILE INDUSTRIES

String and rope are twined by the women from the inner bark of the ambaibo tree. The tree is usually cut down by the men, who remove the outer bark in strips, pull the inner bark from them, and carry this back to camp. It is then thoroughly chewed by the women and placed on a stick over the fire to dry. The resulting shreds are twined into bowstrings, hammock strings, hammock ropes, and baby slings.

One of the most time-consuming activities of the women is the spinning of cotton thread (*nínju*). The spindle is made by the men from chonta palm. It is planed into shape with a mussel shell. It is more or less circular in cross section and about a half inch in diameter at the middle; it is pointed at both ends and is about 3 feet long. The whorl consists of a disk of wood or baked clay which is put on the spindle from the bottom end.

The women prepare the cotton for spinning. The balls of cotton are first collected from the plant and then pulled apart and flattened into paper-thin sheets about 6 inches square from which the impurities are picked out. The cotton is then ready for spinning. During this process the woman is seated, usually in the hammock. The squares of unspun cotton rest on one thigh (a distaff is not employed) and the spindle on the other, with the whorl end resting on the ground at an angle of about 60°. The woman pulls a thread-like line of cotton from one of her squares, attaches it to the spindle, and spins it into thread by rolling the spindle on the thigh from the hip to the knee. As the thread accumulates, it is rolled around the bottom of the spindle. Cotton thread is employed extensively in arrow making, for wrist guards, in twining baby slings, and in decorating the body on festive occasions. It is generally coated with uruku, a red paint made from the seeds of *Bixa orellana*.

The hammock (*kíza*) is the principal article of furniture in every Siriono hut. Hammocks are made by the women from string twined from bark fibers of the ambaibo tree and are very durable,

lasting several years with the roughest treatment. In making a hammock a woman first digs two holes in the ground with her digging stick, as far apart as the length of the hammock is to be. Two posts about 5 or 6 feet long are then planted in the holes. The woman ties one end of her ball of string, previously twined, to the bottom of the post on her right, passes the string around the post to her left and back on the far side around the post on her right, and so on, continuing these winds, which are about one-fourth of an inch apart, up the poles until she calculates that the desired width of the hammock has been reached. The resulting warp strings form two series of parallel lines, one at the front and the other at the back of the posts.

The weft strings are made of the same material as the warp strings, but are finer twined than the latter. They are applied from bottom to top. The weaver places a weft string around the bottom warp string at the front of the posts and midway between them. She holds the warp string with her left hand and pulls both ends of the weft string tightly with the other hand to form two weft strands of equal length. She then takes the under strand in her left hand, crosses it over the upper strand which is held in her right hand, and then transfers each strand to the opposite hand, after which she pulls the twist tightly around the warp string. She then takes the first back warp string, pulls it over until it rests on the twist formed around the first front warp string, and gives the weft strands a second twist. She continues alternately to gather up the warp strings from front to back until all of them are held in place by a weft string, the ends of which are finally tied into a square knot at the top of the hammock. Usually about a dozen weft strings, placed about 6 inches apart, suffice for a hammock. After they have been applied, ambaibo bark fiber is bound around the hammock about 4 inches from each end, and it is then ready for hanging.

Hammocks vary in size, but one shared by husband and wife will be about 6 feet in length and about 4 feet in width. It usually takes a woman a full day to make a hammock, once the string has been prepared. Hammocks are almost always carried along on expeditions or hunting trips, but in case a person gets caught overnight in the forest without his hammock, a rude one is some-

times fashioned of liana in the manner described above.

Baby slings (*erénda*) are twined by the women in exactly the same way as hammocks, the only difference being that they are more often made of cotton than of bark-fiber string and that all the front warp strings are held together by one series of weft strings while those at the back are held together by another. During pregnancy a woman usually twines a new sling so as to have it ready when her infant is born, for a new sling is made for every child. Slings are about 3 feet long and 2 feet wide.

Baskets (*ináku*) are plain and are made by the techniques of checkerwork and twilling. They may be classified into two types: those hastily constructed in the forest for carrying in game, wild fruits, or other products, and somewhat better ones woven for the storing of articles in the house. The former are always made of the green leaves of the motacú palm (by either the men or the women) and are thrown away as soon as their purpose has been served; the latter are more carefully woven (almost always by the women) of the ripe leaves of the heart of the motacú palm, and are a more or less permanent feature of every Siriono hut. Special baskets are made for storing such things as feather ornaments, pipes, cotton and bark-fiber string, necklaces, calabashes, beeswax, and feathers for arrows and ornaments. When the band is on the march, the various small baskets are placed in one large basket and are thus transported to the next camping spot.

In addition to baskets, women occasionally weave mats from the heart leaves of the motacú palm. These are used to sit on, to roll out coils of clay for pot making, and to wrap the bodies of the dead. Fire fans are also woven by the women. The Siriono do not manufacture any type of barkcloth, nor do they use hides for anything but food. Feathers are applied to arrows and are used to make ornaments for decorating the hair, but featherwork as an art is not practiced.

CERAMICS

The pottery industry is poorly developed, but rude, plain pots (*ñéio*) are occasionally made by the women. Since more food is broiled or roasted than boiled or steamed, a family rarely possesses more than one pot.

The banks of rivers serve as the principal source of clay. It is dug out by the women with the digging stick and carried home in baskets. In making a pot, the lumps of clay are first mixed with water and with carbonized seeds of the motacú palm which constitute the temper. The resulting mixture is made into balls, from which coils for the sides of the pot are rolled out, and into disks, from which the base of the pot may be formed.

The base is molded, either out of a disk of clay (in case the bottom of the pot is to be rounded) or out of a small coil (in case it is to be more pointed). It is molded entirely with the fingers, and when finished is placed in a slight depression in the ground into which ashes have been put to serve as a cushion.

The rest of the pot is constructed by the coiling technique. After the base has been molded, the coils are rolled out one by one on a mat of motacú palm and applied in turn. In making a pot a woman works the coils of clay together with her fingers, on which she frequently spits. In addition, she employs the convex surface of a mussel shell called *hitai* to smooth out the clay. After one or two coils have been added to the base of the pot, it is generally left standing to dry for a day before others are added. In this way the pot does not lose shape by having too much weight at the top when the clay is wet. Thus several days commonly elapse before a pot is complete. Once finished, it is left to dry in the shade for about 2 days before it is baked.

Pots are baked in the hot ashes of an open fire. As each section of a pot hardens, it is turned slightly so as to bake another. To maintain an even heat, sometimes a pot is covered with green boughs and chips while it is baking. Since the method of baking is very crude, pots are very fragile and must be handled with great care. They vary in size from about 5 to 10 inches in diameter at the top and from about 8 to 14 inches in height.

Pipes (*keákwa*), like pots, are made from a mixture of clay and carbonized seeds of the motacú palm. The entire pipe, including the stem, is molded from a single disk of clay, the fingers alone being used. As a woman molds the bowl she leaves at the bottom a small lump of clay from which the stem is later fashioned. After finishing

the bowl, she fashions this lump into a conelike shape and then inserts a palm straw into the bowl to make the hole for the stem. She then molds the lump of clay bit by bit around the straw until the stem of the pipe is of the desired length, leaving a little decorative projection at the bottom of the bowl which is called *éka* or teat.

After a pipe has been molded it is dried in the open air for a couple of days and then baked in the coals of a fire as is a pot. In baking, the straw in the stem is burned out, leaving a hole through which to suck the pipe.

Circular spindle whorls are sometimes made by women from small disks of clay hardened in the open fire as a pipe or a pot is. Before they are baked they are fitted on to the spindle so that the hole in the whorl will be of proper size.

UTENSILS

Calabashes (*yabóki*) are prepared as drinking vessels in the following manner. A round hole about an inch in diameter is cut in the top of a gourd with the gouging tool. A small stick is then inserted, and the seeds are loosened and shaken out. The calabash is then washed on the inside and dried slowly in the fire, water being squirted on the outside from time to time to keep it from burning. Calabashes, though used primarily as drinking vessels, are also employed for making mead and for storing tobacco, feather ornaments, and animal teeth.

When calabashes are scarce, hollow sections of bamboo are sometimes used as drinking vessels, to store wild honey, and to make mead. They are simply cut to the length desired.

Mortars (*mbúa*) are sometimes hollowed out of fallen logs that lie near camp, but sections of a log are never cut especially for this purpose; that is, a section of a log is not cut, set up, and hollowed out on the end for use as a mortar. To make a mortar, a hole is made in the side of a fallen trunk with fire, the charcoal being chipped out with a digging stick, which also serves as the pestle. Mortars are used principally for grinding corn for food and mead, and for grinding burned motacú seeds for temper for pots. They are never carried from camp to camp.

No spoons, plates, bowls, or bags are manufactured by the Siriono. Pots and baskets have already been described.

TOOLS

The digging stick (*síri*)—the only agricultural tool—is made by the men from chonta palm. After a section of wood has been removed from the tree, it is planed to the desired shape with a mollusk shell called *urúkwa*. The digging stick is about 3 feet in length, 3 inches in width, and about an inch in thickness. The bottom end is sharpened so as to make it a more effective tool. The digging stick is used principally in planting and tilling, in grinding corn, in digging out clay for pots, and in extracting palm cabbage and honey.

The Siriono construct a gouging tool by hafting an incisor tooth of an agouti or paca onto a femur of a howler monkey. This tool is employed principally to gouge out the nock in the reinforcing plug which is inserted in the feathered end of the arrow. In using the tool the handle is grasped in the right hand with the tooth down. The plug is held in the left hand, and the tool is worked back and forth over it until a groove large enough to hold the bowstring is made. This tool is also employed in making holes in the root ends of the animal teeth from which necklaces are strung.

Some mention should also be made of the use of a mollusk shell, called *urúkwa*, and a mussel shell, called *hítai*, as tools. The former is used by the men as a plane in making digging sticks, spindles, and bows, while the latter is employed by the women to smooth out the clay when making pots. The mandible (with teeth) of the palometa fish also serves as a tool, being employed to sever the aftershafts of the feathers glued on arrows. Any piece of bamboo serves for a knife, but no work is done in bone, horn, shell, stone, or metal. European axes and machetes have been introduced to those bands which have had contact, but under aboriginal conditions European tools are rarely encountered.

WEAPONS

The bow (*ngidá*) and arrow are the only weapons manufactured or used by the Siriono. Every adult male possesses a bow and arrows which he makes himself. So important are these weapons that when not hunting, a man, if busy, is most frequently observed making a new arrow or repairing an old one broken on the last hunt. A man's bow and arrows, in fact, are his inseparable companions. When he is asleep in the house they rest upright against the frame pole to which his

hammock is tied, and when he is walking in the forest he is invariably seen with his bow and a bundle of arrows over his right or left shoulder, points facing ahead, in quest of game.

The wood from which the bows are made is a variety of chonta palm, called *síri*. This tree, when mature, is about 12 inches in diameter and has a layer about 2 inches thick of very hard, black wood just underneath the bark. It is from this layer that the bow is constructed. Although the material is relatively abundant in the environment, before making a new bow a hunter will search for some time to locate a chonta tree which has the appearance of being of proper maturity and hardness. It is a rare tree that has just the right qualities. The wood must be firm and resilient and must withstand the maximum pulling strength of the hunter without breaking. Frequently I have seen a man spend a couple of days in the construction of a bow only to have it snap on the first pull.

After a suitable tree has been sighted it is felled. I have never seen this done other than with an ax, but one of my oldest informants told me that he had known chonta palms to be felled by building a fire against the trunk until the hard layer had been burned through and then pushing the tree over. When a tree has been felled, a section of the circumference of the trunk, about 4 inches wide and as long as the hunter wants his bow to be, is cut out. Other smaller pieces of chonta may also be removed at this time, as this material is likewise indispensable in the construction of arrows.

Once the material has been taken out, work on the construction of the bow begins almost at once, before the wood dries out. Bows are plain and are made of a single stave. The making of a bow is a laborious process, as it is fashioned almost entirely by using mollusk shells, called *urúkwa*, to plane the wood down. A small hole is first made in the surface of one of these mollusk shells. The edges around the hole are then worked downward with the grain, and the section of wood is gradually planed to the desired shape. If a man possesses a machete, he may first use this to give the bow its approximate shape by roughly tapering the horns, but the finishing is always done with the shell to avert the danger of splitting the wood. In planing down a bow it is held securely on the ground between the big and the second toe.

In cross section a bow is roughly oval in shape, being about 2 inches in diameter in the middle and gradually tapered to a cross section of about a quarter of an inch at the horns. The inner side of the hard layer of the tree forms the belly of the bow, while the bark side forms its back. After a bow has been worked to the desired shape, a small amount of bark fiber from the ambaibo tree is wrapped around each horn to keep the string from slipping toward the limbs. The horns of the bow are not notched to hold the string.

The bowstring is twined by the women of ambaibo bark fiber. It is applied as follows. A permanent loop, which will just fit over one horn of the bow, is tied in one end of the string. A half hitch on the other end of the string is placed over the opposite horn and the string is gradually tightened by pulling on the hitch while bending the bow. This is done by resting what will be the top horn of the bow on the ground at an angle and grasping the other horn in the right hand; the left hand is thus left free to manipulate the string which is to be tightened. The inside of the left knee is then placed in the center of the belly of the bow, the foot resting on the back further down. By exerting pressure between the right arm, the knee, and the foot, the bow is bent to the desired degree, and the string is pulled tight by the left hand. To keep it tight a second half hitch is thrown over the first, above the fiber lashing on the horn. The remainder of the bowstring is pulled up the bow to just below the center and wound back around it and over the section of the string which runs up the limb. The end of the string is secured by placing it under a couple of the turns and pulling it tight. The bow is then ready for drawing.

If a hunter is right-handed, as are most of the Siriono, the bow is drawn in the following manner. It is grasped in the middle with the left hand. Because of its great length, the top horn is tilted at an angle of about 30° to the right of perpendicular, so that the bottom horn does not rest on the ground. The hunter spaces his feet from 2 to 3 feet apart, the left foot, of course, always being placed forward.

The secondary release is employed in drawing the bow. The arrow is held between the thumb and first finger of the right hand; the remaining fingers assist in drawing the string. The left arm is held rigid, and the arrow shaft slides between

the thumb and first finger on the side of the bow to the left of the belly. The bow is drawn to a maximum distance allowed by the arms. As the bowstring passes his head, the hunter sights along the arrow to aim. He withdraws his head just before releasing the arrow, and the string flies by his face. He always wears a wrist guard of cotton string to avoid damaging his skin.

The stance indicated above is essentially the same whether one is shooting in a tree, straight ahead, or from a tree into water. If a hunter is left-handed, the procedure of drawing the bow is exactly the same, but reversed.

A new bow is always drawn gradually at first and is sometimes left for one night with the string taut before it is used, so as to give the wood a chance to expand gradually. A bow which is in service, however, is always unstrung following each day's hunt.

After a new bow is made it needs little attention, except for a change of string, until it breaks or has lost its resiliency. The life of a sturdy bow may be a year or more, depending upon how often it is used. A hunter does not make spare bows. Only when his bow breaks or when it has been used so much that it has lost its life does he make a new one. Occasionally, when a hunter notices that his bow is drying out, he places it in water for several nights until its proper resiliency is restored.

Bows vary in size, depending upon the hunter, but all are long, perhaps the longest in the world. On the average they range between 7 and 9 feet in length, although I have seen one that measured 9 feet 7 inches. The Indians themselves have no explanation of why they use such a long bow, other than to say they were taught to do so by their fathers. They assert, however, that a short bow is no good. The explanation is probably to be sought in the manner in which the Siriono use the bow in shooting. It is bent to the maximum distance allowed by the arms before the arrow is released. If a short bow were used, it is likely that the wood could not withstand the strain of the pull or that the hunter would not have sufficient strength to bend it to the desired degree.

Although arrows, like bows, vary in size, only two general types are made: one, called *úba*, with a chonta head containing a lashed barb; the other, called *tákwa*, with a lanceolate bamboo head but containing no barb. The former type is used

almost exclusively for shooting smaller game in the trees, while the bamboo-headed arrow is reserved for killing the larger game on the ground. Chonta-headed arrows average from 7 to 9 feet in length; bamboo-headed arrows, from 8 to 10 feet. The arrows used by the Siriono are probably longer than those used by any other known people in the world.

Except in the case of an emergency or a shortage of material, arrow shafts (*ékua*) are always made of reed (*Gynerium sagittatum*). The plant is found in abundance along the banks of the rivers and at some points inland, but is only suitable for use in arrow making for about 2 months during the rainy season—in March and in April. Consequently, a whole year's supply of not less than 30 reeds is usually harvested during these months. If a man runs out of reeds before the next season comes around, a species of bamboo may be substituted, but this material is considered inferior since it makes an inaccurate arrow.

Like bow making, arrow making is exclusively a task of the men, and, there being no specialists in this occupation, each man makes his own arrows. The reeds are first cut near the butt end and then cured. This is usually done by drying them gradually in the sun for about 4 days, but it may be hastened by the use of fire. Before an arrow is made, the shaft must be straight and dry. While the reeds are curing, a man prepares the other materials needed for the construction of an arrow: feathers, chonta or bamboo heads, beeswax, etc. Consequently, when the shafts are straight and dry, all materials are ready for the construction of an arrow.

A chonta-headed arrow is made in the following way. A shank of chonta wood about 18 inches in length, pointed at both ends, and of a diameter so as just to fit the hollow distal end of the reed, is fashioned with a mollusk shell called *urúkva*. About one-half of this shank is coated with prepared beeswax called *iriti* and inserted up the hollow shaft for about 6 inches. The part of the shaft containing the shank is then loosely bound with ambaibo bark fiber and left to dry. While it is drying, a small conical plug (*eáfa*), likewise coated with hot beeswax, is inserted in the proximal end of the reed. This plug contains the nock of the arrow. After both have dried, the chonta shank and the plug containing the shaft are bound securely in place. This is done with fine cotton

string which has been previously coated with paint made from ground seeds of uruku (*Bixa orellana*) mixed with saliva. To bind the shank, the arrow maker removes the bark fiber and begins to wind cotton string around the shaft about 4 or 5 inches from the distal end, continuing his winds downward until about 3 inches of the protruding shank have been covered; to bind the plug, he begins to wind cotton string around the shaft from the proximal end, continuing his winds about 3 or 4 inches down the shaft. The ends of the string used for lashing are coated with beeswax to hold them in place. The arrow is now ready for feathering. For this purpose only two kinds of feathers (*éó*) are used, except in case of emergency. All chonta-headed arrows are feathered with the large wing or quill feathers of the curassow, while bamboo-headed arrows are feathered with the large wing feathers of the harpy eagle. Informants were emphatic in stating that these are the only feathers ever used, and it was rare that I saw an arrow feathered otherwise. Occasionally, however, the feathers of one of the smaller varieties of guan are used.

Feathering is done by the Peruvian cemented technique. Before a feather is put on, however, about 5 inches of the arrow shaft, below the lashing which secures the plug containing the nock, is coated with hot beeswax. Then the aftershafts of a feather are removed (the mandible, containing teeth, of the palometa fish is used for this purpose) and placed over the soft beeswax along the shaft and in line with the nock. They are then lashed by winding at intervals between the barbs of the feather a very fine thread taken from a grasslike plant growing near rivers, called *dičibi*. Nowadays, when available, manufactured cotton thread is considered ideal for this purpose. After the feathers have been glued and lashed to the arrow shaft, the beeswax is smoothed out by rubbing a wet thumbnail over it.

A single barb (*erási*), about one-half inch in length, is lashed onto the chonta shank of an arrow about half an inch from the point. Barbs are generally made from the hard stays which grow in the soft wood in the center of a palm tree which the Siriono call *hindoéra*, although chonta wood is also used sometimes. The barb is flattened on one end and lashed securely to the shank with fine cotton string coated with beeswax.

Bamboo-headed arrows are made in almost

exactly the same way as chonta-headed arrows except that the bamboo head is lashed onto a chonta shank that is flattened on the distal end. Nowadays, bamboo arrowheads are cut out with bush knives, but formerly they were shaped with mollusk shells. They are glued to the flattened chonta shank with beeswax and lashed tightly to it with cotton string covered with uruku paint.

After an arrow has been finished it should have a certain twang when set in vibration. This is tested as follows. The maker grasps the arrow in about the middle of the shaft with his left hand and lifts it up to the height of his eye. While sighting along the shaft he grasps the nock end of the arrow between the thumb and first finger of his right hand and bends the shaft slightly toward his face. He then releases his fingers with a snap and the arrow, if a good one, vibrates with a twangy sound. An arrow which does not produce this sound when set in vibration is thought to be a poor one.

Arrows are always retrieved and are frequently damaged on the hunt. If the shaft of an arrow is broken, a cross section is cut off evenly on both sides of the break, and a pencillike rod of chonta palm wood, about 6 inches long and covered with beeswax, is inserted about 3 inches up the hollow shaft of one part of the broken reed. The protruding piece of the chonta rod is then inserted into the hollow shaft of the other part of the broken reed until both parts of the reed meet. To complete the job of mending, cotton string is wound around the shaft for about 3 inches over the break.

Some mention should also be made of the use of pieces of wood as weapons. Clubs are never manufactured but chunks of wood cut or picked up at random sometimes serve as clubs to kill wounded animals and to pound with.

HOUSING

To judge from the type of house constructed, the problem of shelter among the Siriono is not a serious one. Little time is spent in making a dwelling, nor when built does it comfortably protect them either from the inclemencies of the weather or from the ubiquitous insect pests that continually harass them. The house, whether shared by the entire band or hastily erected by a single family or hunting party on the march, is always the same general type, although varying

in size and degree of completeness. It consists of a roughly rectangular frame of poles against which are set, at an angle but not bound together, the long leaves of the motacú palm. The house is thus but an elaboration of the most simple type of lean-to or wind screen.

No one person supervises the construction of a house. Before building one, a site is selected by general agreement. It must be near water and relatively free of underbrush but at the same time should contain a few sturdy trees to serve as upright supports or columns upon which to lash the frame. Care is taken to select a spot which contains no dead or rotten trees that may fall over during occupancy. However, trees are never cut down to clear a house site; rather, the house is built around them.

After a site has been selected, the men go in quest of poles for the frame. Nowadays these are cut from nearby trees with machetes, but formerly they were doubtless hacked off with the digging stick. No particular type of wood is specified for the construction of the frame, although frequent use is made of soft chonta palm trunk and of heavy bamboo, which is abundant in certain parts of the area. The sturdiness and size of the poles for the frame depend upon the number of people who will occupy the house. They must be of sufficient strength to withstand the weight of all the people in the house, since their hammocks and gear are tied to the poles of the frame as well as to the trees onto which they are lashed. If the distance between the trees to be used seems too great to bear the weight that the poles will have to support when they are lashed between them, additional forked trunks are sunk upright in the ground by digging them in with the digging stick to add further support to the frame.

The poles, when cut, are lashed to the outer side of the trees and in the forks of the upright columns with lianas, which are wound several times around the poles and the supports until they are secure. This liana lashing is fastened with half hitches. The entire frame is bound to the trees and to the upright supports at a height of about 5 feet above the ground.

The next and final operation in house building consists merely in setting against the frame, at an angle of about 60° from the ground, several layers of the green leaves of the motacú palm.

These leaves, which form both the walls and the roof, are placed with the butt end on the ground. As they are about 15 feet long, they bend rather sharply at the top, so that when they have been placed around the whole frame, the house has a somewhat conical appearance. Often the leaves are not long enough to meet at the top, thus leaving a gap through which the smoke from the fires between every two hammocks escapes, and through which the rain enters freely during a storm. The house contains no doors or windows; one merely works one's way in through the palm leaves.

Nuclear families on a hunting and gathering expedition, when they may be absent from the band for from a few days to several weeks and are rather constantly on the march, take even less trouble in the construction of a nightly shelter. All they build is a rude shelter constructed like one side of the above-described house. The Siriono country is dotted with the remains of shelters erected by hunting parties that have stopped there for a night or two in their wanderings.

Having roamed over an extensive part of the area where the Siriono are accustomed to travel throughout the year, I can report that these are the only types of shelters that I ever saw built. When it rains, a shelter is improved to the extent that a few large leaves of patujú—a wild plant resembling the banana plant but not producing fruit—may be placed between the layers of motacú leaves and over the hammock where an individual sleeps, but such improvisations are rarely adequate to give one a dry night of rest if the rain is more than a sprinkle. On occasions when it rains heavily—and this happens on the average about 2 or 3 nights per week during the rainy season—the Siriono grumblingly takes down his hammock and squats by the fire, which is always carefully protected from the rain by leaves of the patujú, until the downpour passes. Consequently, he undergoes many a sleepless night during the year.

The building of a house entails no magical procedure, and it is almost always exclusively a task of the men. Arriving at a new camp site, the women are usually immediately occupied in tending their children, unpacking their gear, carrying water, and kindling a fire for cooking what victuals the day's march and hunt may have yielded. Meanwhile the men work cooperatively in cutting and lashing the poles for the frame.

The number of leaves placed against the frame, however, is largely an individual matter; if a man makes no move to cover that part of the frame where he will sleep with his family, no one else will bring leaves to cover his section of the house for him. At best, rarely more than two layers of leaves are placed over the frame. Moreover, a new house is never built larger than a size just sufficient to accommodate the people present at the time of building. If families are away from the band at the time, additional space is not provided to accommodate them, and when they return they themselves will have to add a section to the main house.

The average house sheltering a band of from 60 to 80 people is approximately 60 feet long, 25 feet wide, 15 feet high at the center, and about 5 feet high at the frame. It can be constructed in about an hour's time. Seldom is more than 15 minutes or a half an hour spent in the construction of a lean-to for the night.

Other types of buildings, such as cook houses, granaries, and club houses, are not built. A Siriono settlement consists of but a single hut, constructed in the manner described above.

The determination of why the Siriono maintain such an apathetic attitude toward house building and sheltering themselves from the unpleasant aspects of their environment, such as rain, cold winds, and insect pests, presents an interesting psychological problem. When first traveling with them, I was puzzled at why they even took the trouble to place a few leaves over their hammocks, since these seemed to offer them no visible protection. On closer scrutiny, however, I found that the few leaves placed over their hammocks did protect them from twigs and small branches which are continually falling from tropical trees in the night. Moreover, placing a few leaves over the hammock protects them from the rays of the moon, which are believed gradually to cause blindness if they fall directly on a sleeper. Other than this, the shelters of the Siriono seem to offer them little protection.

The house is but sparsely furnished. The hammock is the principal article of furniture. Hammocks are suspended across the width of the house with bark-fiber ropes tied to the frame poles and columns. Household articles such as calabashes and baskets are suspended with bark-fiber string from the midribs of the palm leaves that

form the walls and roof. Pots are left on the dirt floor. Houses are almost never cleaned. When they become unbearable new ones are built.

DRESS AND ORNAMENT

No clothing of any kind is manufactured or worn by the Siriono. The nearest approach to clothing—a custom probably adopted from the Brazilian Indians—I found among the easternmost Siriono. Here I observed some young boys, and a few young men of puberty age, wearing a twined G string of bark fiber wound tightly around the waist; under this the foreskin of the penis is tucked so as to lengthen it. Where clothes have been introduced, however, they are greatly sought after, not so much because of modesty⁴ but because clothes both adorn them and protect them to some extent from the ubiquitous insect pests that continually harass them. That they are mostly desired for adornment, however, is attested by the fact that no matter how many clothes they possess they always sleep stark naked at night when the insects are most abundant. Moreover, if a woman does possess a dress, before sitting down she always lifts it up and sits on her bare skin in preference to soiling her garment.

Even though they wear no clothing, the Siriono are rarely seen without some type of embellishment. Most commonly employed to decorate the body is a paint made from the seeds of the uruku plant, which is extensively used for ornamental purposes by many South American Indians. By spitting on the hands and mixing the saliva with a few uruku seeds a bright red paint is produced. This paint, which is never applied in any type of design, is rubbed especially on the face, but on some occasions the entire body is covered with it. Its function is both sacred and secular. Although its magical significance is of prime importance on such occasions as a birth or death, and in warding off illness, the body is covered with uruku for utilitarian reasons, namely, as a protection from insect bites and cold weather when mosquitoes are thick or when a cold south wind blows. Like the channel swimmer who shuts out the cold by

covering his body with Vaseline, the Siriono does so by covering his body with uruku.

Next in importance to uruku for decorative purposes are various bright-colored feathers (*éó*) which are glued into the hair with prepared beeswax (*iríti*). Like uruku, feathers are extensively employed to decorate the hair on festive occasions. It is important to note that the same types of feathers are always used no matter what the occasion may be: a birth, a death, a drinking feast, or a bloodletting rite. Those employed come from the toucan (red feathers from the back, yellow feathers from the breast, and white feathers from under the wings), from the curassow (downy white breast feathers), and from the harpy eagle (also the downy white breast feathers). Although there are many other brightly colored birds in the area—the macaw, for instance—the types mentioned above were the only ones I ever saw used for decorative purposes. The underlying reasons for this, other than that the ancestors had followed the same pattern, I was never able to ascertain.

It is the women who pluck the feathers, prepare them into tufts, and glue them into the hair. In the case of the toucan, when the bird is killed the breast skin is always removed with the feathers, which are later plucked for decoration. In the case of the other birds mentioned, the desirable feathers are plucked after the dead animal has been brought to the house. The tufts are made by first binding 8 or 10 of the down feathers together at the base with a piece of cotton string or bark fiber and then covering the binding with prepared beeswax. The tufts are glued to the hair by first softening the beeswax with a firebrand.

In addition to tufts of feathers, bunches of quills of the peccary, porcupine, and paca are sometimes glued into the hair of young boys so as to make them good hunters of these animals when they grow up.

Necklaces (*éwi*) are worn both for adornment and for magical reasons. Animal teeth are especially favored in necklace making. When a coati is killed and after it has been cooked and eaten, the eye teeth are extracted with the fingers and small holes are gouged out in the roots of the teeth by the men, who employ for this purpose an eye tooth of a rat, a squirrel, or a paca hafted to the humerus of a howler monkey. After a sufficient number of teeth (no specified number) have been obtained, they are strung on a piece of cotton

⁴In this connection, about the only thing a Siriono man is modest about is displaying the glans of his penis, and when standing around he is constantly tugging at the foreskin so as to lengthen it. Women likewise display little modesty, but when sitting on the ground they always cover the vulva with one heel.

or bark-fiber string by the women. The penis bone of the coati or the gristle from the back of the ankle of the harpy eagle is sometimes added as a charm to these necklaces, which are worn especially by parents during the couvade period following birth.

Less often employed for making necklaces are the eye teeth of the spider monkey, which are drilled in the manner described above. Necklaces are sometimes made from the molar teeth of the peccary and the coati, but in such cases holes are not drilled in the teeth; they are merely tied to string which is placed around the teeth between the roots.

The hard black seeds of the chonta palm and toenails of the tortoise are sometimes drilled in the manner described above and are used for making necklaces. The base of the quill feathers of various birds, especially the parrot, the macaw, the harpy eagle, and the toucan, are also similarly employed. In the case of the toucan the wind-pipe may be dried, cut into sections, and strung into necklaces. Other products employed for making necklaces include small sections of young chuchio (the reed employed in arrow making), old hair wrapped in cotton string, sections of umbilical cord (also wrapped in cotton string and covered with beeswax), and even parts of discarded pipe stems.

Age, sex, and status differences do not affect the wearing of necklaces, although, as we shall later see, certain ones seem to be worn only on specific occasions.

Some mention should also be made of the widespread use of cotton string covered with uruku for magical and decorative purposes. This is wound around the wrists, the arms (above the elbows), the ankles, the legs (below the knees), and the neck of the father and mother after the birth of a child, and is worn for approximately a month thereafter. No rings, ear, nose, or lip ornaments are ever worn.

The only type of body mutilation found among the Siriono results from the practice of ceremonial bloodletting, which will be discussed more fully later. Suffice it to say here that the adult men and women are stabbed in the arms (the men on the inside of the arms from the wrist to the elbow and the women on the outside of the arms from the elbow to the shoulder) with the dorsal spine of the sting ray. When the wounds from these

stabbings heal, there remain a series of decorative scars, which are both tribal marks and signs of adulthood. Although bloodletting occurs on other occasions, the scratches made in the skin then are usually so superficial as to leave no scars.

No age, sex, or status differences are manifested in hair styles. The only exception occurs in the case of young girls (*yukwáki*), who have their heads entirely shaved before undergoing the rites to make them eligible for sexual intercourse and marriage. Young children receive their first haircut in the tribal style the day after they are born.

Hair is cut by the women with a piece of bamboo. There are no specialists who perform this task. A woman usually cuts her husband's and her children's hair, and her own is cut by a sister or a cowife. The hair is cut to a length of about a quarter of an inch all over the head. That over the forehead is pulled out, or shaved with a bamboo knife, to a very high semicircle. The ears are left exposed. In the back, the hair is cut straight across at about the level of the lobe of the ear. Haircuts are given about once a month, although the forehead and eyebrows may be depilated as often as every 10 days. For depilation the woman covers the tip of her index finger with beeswax and grasps the hairs between her thumb and index finger. After the hair has been removed, the entire forehead is covered with uruku, which acts as a healing balm. In the case of young children, to promote the future growth of the child's hair, a few feathers of the harpy eagle or the curassow may be glued to the back of the hair after it has been cut.

The disposition of hair clippings varies with age. In the case of young children the hair is saved, wrapped in cotton string, covered with hot beeswax, and tied around the neck of the child or his mother. The purpose of this is to promote the future growth of the child's hair and also to prevent the child from becoming sick in the head. In the case of adults the hair is thrown away deep in the bush, although I also observed in Casarabe that it was sometimes buried in the ground just outside of the house. Informants told me that leaving old hair around was apt to cause headache. Nail clippings receive no special treatment.

Beards are more rarely cut than the hair, but occasionally they are shaved off completely to

promote the growth of an even longer beard. Mothers sometimes glue a few beard hairs of the paca into their boys' hair to insure that their infant sons will possess a heavy beard like a paca when they become adults. Hair from the beard, like that from the head, is discarded in the bush or buried. The same may be said of axillary hair, which is removed when present. On the whole, however, the Siriono possess little body hair, and most of what they do have is rubbed off by the brush of the forest. Pubic hair is never removed.

PROPERTY

The native concept of property may best be expressed by saying that the environment exists for the exploitation of all members of the band, and that the society recognizes the rights of ownership only so far as this exploitation is pursued. In other words, the preserve of the Siriono is communally owned, but its products become individual property only when they are hunted, collected, or used.

Actually, little real property exists. What does exist is limited to the immediate possession, by a family, of a garden plot, by virtue of having cleared and planted it, or to the right to collect from certain fruit trees, by virtue of having discovered them. When a man comes across a new fruit tree, he may mark it with a notch; this will give him the right to exploit it (for one season at least) while it is bearing fruit. Such rights, however, do not extend to hunting grounds, fishing sites, stands of arrow reeds, uruku trees, or calabash trees, all of which are regarded as public property. The house is both communally built and communally owned.

Since the material apparatus is sparse, holdings in movable property are few. As regards all of these possessions, however, individual rights of ownership are recognized and respected. Thus a man is owner of his bows and arrows, the animals which he kills, the maize or manioc which he raises; a woman is the owner of her pots, cala-

bashes, baskets, necklaces, feather ornaments—in fact, all of the things which she herself makes or collects. In some possessions, such as pipes and hammocks, which are used by both the husband and the wife, ownership, of course, may be regarded as joint.

The sparsity of material culture limits transactions in property largely to exchanges in food. However, these are not carried out on the basis of barter, or buying or selling. Such notions are foreign to the Siriono. Nevertheless, the giving of food does involve an obligation on the part of the recipient to return food to the donor at some future date. For instance, if a man hunts a tapir, which he is forbidden to eat for magical reasons, part of the meat may be distributed to members of his wife's family. The next time the recipients hunt tapir they will be expected to return meat to the original giver. This type of exchange is about the only property transaction that takes place in Siriono society. Marriages and divorces, for example, are not accompanied by an exchange of property. Borrowing or lending almost never occurs; one's neighbor rarely has anything that it would be useful to borrow.

As a consequence of not accumulating property—a notion foreign to the Siriono—the problem of inheritance is greatly simplified. Actually, it hardly exists, for when a person dies most of the things with which he has had intimate contact are placed with the body or thrown away. Thus one's pots, calabashes, pipes, and feather ornaments are left at the site where the body is abandoned. Exceptions include hammocks, necklaces, cotton strings, and sometimes a man's arrows, particularly if he has been a good hunter. These may pass to his son or to his brother, while the few possessions of a woman usually pass to a sister or a cowife, though they may also be inherited by a daughter. Thus inheritance of possessions may be either patrilineal or matrilineal, depending upon the objects and persons involved. Succession to chieftainship, however, follows patrilineal lines.

EXPLOITATIVE ACTIVITIES

SEASONAL CYCLE

In contrast to most other aboriginal peoples of the area in which they live, the Siriono are semi-nomadic forest dwellers who live more by hunting,

fishing, and gathering than they do by farming. All of their economic activities, of course, are governed to a considerable extent by the seasonal changes which take place throughout the year. During the periodic inundations which last from

December to May, when the whole area, except for small islands of high ground, becomes one huge swamp, the mobility of the group is considerably impaired. Consequently, at the beginning of this cycle a stretch of high ground containing an abundance of palm trees and wild fruits is selected for occupation during the flood months, and the wild fruits are harvested as they mature. Such hunting as is possible (considerable game is attracted by wild fruits) is done, but fishing becomes a negligible activity, since the waters become turbid. The diet at this season of the year consists principally of wild fruit and vegetable food, and the band is a fairly cohesive social unit.

In sharp contrast to the sedentary mode of life during the rainy season is its nomadic character during the dry season. After the crops have been harvested in April and May and after the waters have begun to recede in June, the entire band may

start out on a hunting and gathering expedition, wandering from lake to lake, from stream to stream, exhausting the wild life of each as it travels. Consequently, meat, fish, and wild honey become more prominent in the diet at this season of the year, and the band becomes a loose social unit.

When the next rainy season arrives, the band may return to the same spot occupied the year before or it may move on to another. This depends largely on the quantity of food available. Having wandered for years over the same large area, the Siriono possess many sites containing old gardens, uruku trees, calabash trees, etc., to which they may return from time to time in their wanderings.

Table 1 is a calendar of the chief economic activities carried out and the principal foods eaten throughout the year.

TABLE 1.—*Calendar of chief economic activities and principal foods eaten*

Month	Activities	Foods eaten
January	Hunting and collecting; little or no agricultural work; group usually sedentary because of the rainy season.	Game; palm cabbage; motacú fruits.
February	Hunting and collecting; harvest of maize planted in November; harvest of wild fruits begins; group sedentary because of rainy season.	Game; palm cabbage; motacú fruits; papaya; maize; some manioc; coquino; agual; hindoera; gargatés; pacáy; pacobilla.
March	Hunting and collecting; no agricultural work; principal harvest of wild fruits; group sedentary because of rainy season.	Game; palm cabbage; motacú fruits; papaya; maize; some manioc; coquino; agual; hindoera; gargatés; pacáy.
April	Hunting and collecting; group still sedentary; harvest of wild fruits almost over; little or no agricultural work.	Game; palm cabbage; motacú fruits; papaya; coquino; agual; little maize and manioc.
May	Hunting and collecting; harvest of chuchio begins; making of new arrows; group begins to be more nomadic; possible replanting of maize.	Game; palm cabbage; motacú fruits; little manioc; maize and papaya.
June	Hunting and collecting; extended families become more nomadic; hunting expeditions; fishing begins; harvest of chuchio terminated; almost no agricultural work; band as a whole may decide to migrate to other spots for better hunting and fishing.	Game; palm cabbage; motacú fruits; little manioc; maize and papaya; some fish and wild honey.
July	Usually on the march; hunting and fishing; no agricultural work	Game and fish; palm cabbage; wild honey; motacú fruits; cusi nuts; some camotes.
August	Usually on the march; may return to eat camotes and fresh maize planted in May; hunting, fishing, and collecting chief economic activities; drinking parties occur because of abundance of wild honey.	Game and fish; palm cabbage; wild honey; camotes; maize; cusi nuts; motacú fruits; also a fruit called <i>ndia</i> .
September	Usually on the march; hunting, fishing, and collecting; many drinking parties.	Game and fish; palm cabbage; wild bee honey; motacú fruits; camotes; little manioc or maize; turtle eggs.
October	Hunting and collecting; clearing small plots for planting; during this month the group usually selects a site to weather the rainy season.	Game; fish; palm cabbage; motacú fruits; some camotes; little manioc, maize, or papaya.
November	Hunting and collecting; most of the planting occurs in this month; maize, manioc, cotton, and tobacco are sown; since agricultural activities are limited, they interfere little with hunting and collecting; fishing stops because the waters begin to rise and become turbid.	Game; little fish; palm cabbage; motacú fruits; few other vegetable products.
December	Rainy season begins in full force; no agricultural work; hunting and collecting are the only important activities; wild fruits have not yet begun to ripen.	Game; palm cabbage; motacú fruits; few other vegetable products.

HUNTING

No other activity of the men can match the importance of hunting. The temper of the Siriono camp, in fact, can be readily gaged by the supply of game that is daily being bagged by the hunters; there is rarely ever equaled that joy which follows a successful chase or that discontent which follows an unsuccessful one.

Around every Siriono hut there are trails, scarcely visible and marked only by an occasional bent leaf or twig, spreading out in all directions. On any morning just before daybreak it is a common sight to see the naked hunters, bows and arrows over their shoulders and perhaps with a piece of roast manioc in their hands, silently fading into the forest in all directions in quest of game. Some go alone; others in pairs; still others (as many as six or seven) may join together to go in quest of a troop of peccaries or a band of spider monkeys.

Besides his bow, each hunter takes with him about eight arrows—five with a barbed chonta head to hunt small tree game and three with a bamboo head to hunt larger ground game. As he leaves the hut the hunter walks silently but rapidly through the forest so as to arrive early at those spots such as water holes most likely to contain game, and as he goes along he searches the branches above him and the forest around him for a stirring leaf or a snapping twig that might indicate the presence of game.

Almost all animals of the environment except snakes are hunted, and various techniques are employed to bag game, depending upon the type of animal one encounters. Since the bow and arrow must be depended upon exclusively, and since the quarry must be close to be shot with such a cumbersome weapon, the Siriono is a master at both stalking and imitation. He can imitate to perfection the whistle of a bird, of a monkey, of a tapir, or the call of a peccary. There is not an animal sound of the forest, in fact, which he does not know and is not able to skillfully imitate. In hunting guan, for instance, he whistles like one of the young; if there is a guan within hearing, it is brought within range of the bow by this means. I have frequently seen guan brought to a branch within 10 feet of a hunter, and on one occasion, during the mating season, I saw one brought so

close by this method that it was actually caught alive in the hunter's hand.

So as not to disturb his quarry, a hunter refrains from talking when in quest of game and communicates with his companions largely by whistling. This specialized language has become so highly developed among the Siriono as to enable hunters to carry on limited conversations, and it is often used to advantage. On one occasion, when I was hunting with two Indians along the banks of a brook, my companion and I, who were on one side, suddenly heard a whistle from the opposite bank, along which the third member of our party was walking. We stopped immediately and my companion answered the whistle, to which the other replied in turn. After several moments of whistling conversation my companion selected an arrow, put it in his bow, walked a few feet ahead, aimed into a tree, and released the arrow. Down fell a curassow, much to my surprise. What had occurred was that our comrade on the other side of the brook could see the bird, which was not visible to us, but it was out of range of his bow. As it was possible for us to get in range, he indicated by whistling the location of the bird, so that it was relatively easy for my companion to walk to the spot and shoot it.

Other types of cooperation between hunters have developed because of unusual circumstances encountered in the jungle. The area, for instance, contains many tall trees in which game is sometimes situated at such a height that it is out of range of the bow. If a hunter is alone he will usually be forced to pass up such game, but if a companion is with him they may cooperate in making an effort to secure it. This is done in the following manner. One of the hunters slings his taut bow over his back and climbs up the tree to a branch that is within range of the animal. If the trunk is of such thickness as to prevent him from climbing directly up the tree, a sapling is cut and bound to the trunk with liana. He then climbs this sapling until the branches of the tree can be reached. Once in position to shoot the animal, he signals to his companion below, who puts an arrow into his bow and releases it with just enough force to reach the hunter aloft. The latter, as the arrow goes by, grabs it, puts it in his bow, and shoots the animal. This is by no means a common method of hunting and is practiced only in case the animal in the tree is one

not likely to move, such as a female howler monkey whose male companion has been killed. However, I witnessed it several times while I was living with the Siriono, and in each instance the game was bagged.

The animals most frequently bagged are monkeys, of which there are several kinds in the area. Most abundant is a species of capuchin monkey, called *keN*. If a hunter comes back from the chase with anything, he is most likely to have one or two *keN* in his catch. These monkeys travel in groups as large as a hundred, and, as there are always many young ones in the band, their whistling can be heard from a great distance away. Upon hearing these sounds, the hunter stops and whistles like the monkeys (I was never able to distinguish the whistle of a monkey from that of a hunter), gradually bringing them closer to his post. By hiding behind a tree, he is usually able to shoot one or two before the rest of the band sees him, becomes frightened, and begins to disperse. When this occurs, he selects one of the larger monkeys and gives chase, trying to drive it into the open where it can be shot. If in flight the monkey hides momentarily in the thick foliage above, the hunter tries to rout it out by tugging on one of the lianas which grow to the ground from almost every tree. Getting into position to shoot one of these monkeys, however, is not easy, as they move from tree to tree with great rapidity and stop only momentarily. Moreover, the underbrush below is extremely dense with lianas and spines, so that a hunter's progress is often impeded to such an extent that he loses his prey.

Next in abundance to the *keN* are the long-haired, black spider monkeys called *erúbat*. These are more highly prized than the *keN* because of their size (10 to 20 pounds). Spider monkeys are especially valued during the rainy season, because at this time they are very fat from eating the wild fruits that mature in February, March, and April. Sometimes these monkeys have as much as a half-inch of fat on their bellies.

Spider monkeys are chased and bagged in the same manner as the above-mentioned *keN* but are less difficult to shoot because of their greater size and sluggishness. They often await their fate, shaking the branches of a tree at the hunter. Nevertheless, they may cause the hunter a considerable amount of trouble, since they generally

break his arrow between their hands when dying and, once dead, they are able to hang to a branch with their strong prehensile tails for as long as 24 hours, thus forcing the hunter to climb the tree to retrieve them.

A third type of monkey that contributes considerably to the food supply is the howler or *téndi*. Unlike the spider monkey, the howler does not travel in large bands but in polygynous family groups that vary in size from a male and two females to a male and six females. When hunting the howler, an Indian usually tries to bag the male first; the females will not then move from the area, and he can hunt them down one by one. After the male has been killed, the females often cluster together high in a tree, from which they do not move, and the aforementioned method of cooperative hunting can be applied to kill them.

In addition to the types of monkeys already mentioned, there are three smaller varieties that the Siriono occasionally hunt but which do not contribute much to the food supply. These are a small owl monkey, called *yikína*, and two varieties of squirrel monkeys, called *giñeti* and *ngí*. They are hunted in the same manner as the others, being chased from tree to tree until they are bagged.

Next in importance to monkeys in supplying meat for the camp are the numerous land and waterfowl of the area. These include, chiefly, several varieties of guan (*yáku*), curassow (*bítóN*), macaw (*kirínde*), toucan (*yisádi*), parrot (*yikána*), duck (*yéi*), cormorant (*míNgua*), partridge (*námbu*), hawk (*ngída*), egret (*gwaríši*), and vulture (*urúbu*). On the pampa there are other large birds, such as the South American ostrich (*ngidáçibaia*), but as the Siriono with whom I lived were strictly a forest people, these were never hunted. All birds are shot with the bow and a barbed, chonta-headed arrow. They are usually brought into range by careful stalking or by imitating their calls.

The pursuit of the collared peccary (*tai*) and the white-lipped peccary (*çíasu*) constitutes an important part of the chase and contributes much to the meat supply. The former, which are usually observed foraging in the forest in groups of from 2 to 10, are quite abundant, and the latter, which are sometimes found in bands of as many as 200, are not infrequently encountered.

Collared peccaries are usually heard rooting

nearly as one goes through the forest. Upon discovering them the hunter prepares his bow for the kill, imitates their call, and shoots them as they come within range, aiming for the heart or the neck.

White-lipped peccaries can be discovered a great distance away, both by smell and sound. Moreover, they are one of the few animals that the Siriono spend days in tracking down and are also one of the few that are sometimes hunted cooperatively. As band peccaries are accustomed to follow a leader, and to root up almost everything as they go along, to track them down is not a difficult task.

To originate a cooperative peccary hunt some hunter must previously have sighted fresh tracks relatively near camp, say within a half day's distance on foot. On the day following the report, the hunters set out, using the person who discovered the trail as a guide. They take with them only their bamboo-headed arrows (*tákwa*), as only these are effective in killing such a large animal. Arriving at the trail, they follow it until they can hear the noise of the peccaries, which is not unlike the sound of distant thunder—the reason perhaps that the Siriono have associated thunder with the falling of peccaries to the earth.

After the band has been discovered, the hunting party stops and lays plans for the kill. If the chief is present—he is always one of the best hunters—other members of the party usually accept his method of attack. A band of peccaries is always approached against the wind, so that the hunters will not be discovered. If it is possible to come up from behind the band, this is considered the best strategy. In any case, an attempt is always made to circle the band so as to kill as many peccaries as possible. Some hunters approach from the rear; others from either side. The signal for the kill is given by the hunter first getting in position to shoot: the arrows then begin to fly from all directions. Each hunter usually picks a fat peccary for his first arrow. If possible, the leader of the band is also killed, not only because it is generally the biggest boar but because the band will thus have greater difficulty re-forming and the other peccaries will be easier to kill.

On a chase of this kind a hunter usually uses up all the arrows he has brought with him, but if

there is still game around this does not deter him from continuing the hunt. He may continue the attack with a club picked up at random or cut in the forest. I have even seen hunters catch young peccaries with their hands and bash their heads on the nearest tree or drown them in a water hole that happened to be at the site of the kill.

After the band has dispersed and the principal kill has been made, strays are run down and slain. It is only after no more animals are available that the slaughter is stopped. The hunters then meet at the place where the kill began, dragging all the game to that spot. If the day is yet young, i. e., before noon, if the kill is such that it can be carried home, and if the camp is not far away, they may set out for the house at once. Usually, however, they decide to remain overnight in the forest and roast the meat. If it is late in the day, they spend most of the night preparing and roasting the game, and on the following day, after an all night feed, carry the roasted meat to the camp in rude motacú palm baskets. In case raw game must be left in the forest for a night, the viscera are removed, and the carcasses, covered with palm leaves, are tied in a tree to safeguard them from ants and jaguars. On the following day the women are sent to bring in the game.

The Siriono who wander in those regions west of the Rio Blanco, where there is open country, frequently encounter the large pampa deer (*kiikwandúsu*). Those who inhabit the forest country east of the Rio Blanco most often meet a smaller variety of forest deer (*kiikwa*).

When in quest of the pampa deer, the hunter tries to reach the pampa as early in the day as possible. On arriving at the open country, he may sight his quarry a great distance away. Deer are relatively easy to stalk, as the tall grass of the pampa (frequently higher than one's head), as well as the ant hills, provide an almost perfect blind. The naked hunter must proceed cautiously, however, else the knifelike blades of some of the pampa grasses will cut his skin to ribbons. In killing deer the hunter always aims for the heart.

The tapir (*eakwantúí*) is the largest animal in the area, and since its carcass yields the greatest amount of meat of any animal, it is considered the greatest prize of the chase. Because of the undeveloped hunting techniques of the Siriono, and because the tapir does most of its feeding at night, when the hunter is fast asleep, it is rarely

bagged. Only four were killed by the Indians at Tibaera during my residence of about 8 months, although many more were shot.

Even at daybreak, when the hunter is alert, the tapir has already retired to sleep in the spiny, liana-covered underbrush into which it is difficult for the hunter to penetrate, and since he possesses no dogs to rout his prey, he rarely runs across one in his wanderings. Moreover, a tapir is hard to kill and, when discovered and shot, frequently escapes into a swamp where the pursuer dares not venture.

The few tapirs that are killed are usually shot while they are asleep. They are often detected by a short shrill whistle which they make at this time. They may also sometimes be located by the call of a small bird, known to the Siriono as *eakwantú iča*, which accompanies the tapir and lives largely by eating the wood ticks from its body. The call of this bird is a clear sign to the Indian that there is a tapir not far away. Once the sleeping animal is discovered, the hunter sneaks up quietly to within a few feet and shoots it in the heart with a lanceolate bamboo-headed arrow. If a feeding tapir is discovered in the daytime, the hunter conceals himself in the brush nearby and whistles like another tapir until the animal comes within range of his bow. He then aims for the heart and having released his arrow gives rapid chase until the bleeding animal falls.

The alligator (*yikári ekwásu*) is one animal which is truly abundant in the area, particularly during the dry season when the waters are low and when they lie on the sand banks to sun themselves or come further inland to lay their eggs.

Alligators are hunted both with a bow and arrow and with a club. Arrows are employed when alligators are in the water with their heads up for air; clubs, when they are lying in the open sunning themselves. When shooting an alligator, which is difficult to kill, the hunter aims either for the eye or for the region just back of the shoulder. After being hit and thrashing around for some time in the water, the animal usually comes to the surface and can then be retrieved. If not, the hunter may wade in, taking with him an arrow to locate the beast by feeling around on the bottom. Once the animal is located, the hunter goes under water, grasps it by the tail, and slowly drags it ashore. As these reptiles sometimes live for an hour or two after they are shot, considerable time is allowed

to elapse before any attempt is made to retrieve them. In case they are encountered in the open they are clubbed on the head until dead.

Newborn alligators are sometimes used by hunters to attract the mother. When a young alligator is caught it begins to cry for its mother, who, upon hearing it, comes running out of the water to retrieve it. The hunter, waiting on shore, strikes the mother over the head with a club as she comes up the bank. By imitating a young alligator a hunter can often produce the same result.

Alligator hunting is regarded as a precarious business, and the hunter takes care so as not to get bitten. While I was living at Tibaera an Indian named Eabokóndu (Father-of-Long-Hair), while fishing at the edge of a lake, was surprised by an alligator and bitten on the upper leg. He saved his life by jabbing the point of an arrow into the alligator's eye, but was left with a nasty wound that did not heal over for several months.

Coatis are generally killed in the trees with barbed chonta-headed arrows. When a troop is discovered, a hunter is rarely able to kill more than one before the rest of the band takes to the ground in flight. When this happens, the hunter drops his bow and arrows and gives chase through the brush. I have seen coatis overtaken in this fashion. They are seized by the tail and their heads bashed on the ground, or they are hit with a club picked up at random. Not infrequently a hunter is bitten or gashed by the sharp eye teeth of the coati while making his catch.

The jaguar (*yákwa*) and the puma are rarely encountered in the forest. They are mostly found on the pampa. Only one large jaguar and three small ones were killed by the Indians while I was living with them. Jaguars are shot, either in the trees or on the ground, with bamboo-headed arrows.

The giant anteater (*antandiša*), being a slow animal, is generally killed with a club. Only in case one is discovered in a tree is it shot with a bow and arrow. The same may be said for the smaller variety (*antanbúja*). The honey bear when encountered tapping a hive of wild bee honey is shot with the bow and arrow.

Armadillos (*tátu*) are usually routed from their holes with a long flexible midrib of motacú palm, and are clubbed as they come out. If caught outside their holes they are shot in the head with an

arrow. The same methods are used with the paca (*titimi*). The agouti (*taiku*) is more generally shot while feeding on wild fruits which have dropped from the trees in the forest.

Most hunting is done individually or in groups of two or three. Game is carried in from the forest on the hunter's back. The animals are bound together with liana and suspended from the hunter's head with a tumpline of liana. Each hunter carries in his own game.

FISHING

Unlike many of his South American Indian contemporaries, who developed or adopted the fishhook, traps, nets, or poisoning as methods of catching fish, the Siriono does all his fishing with the bow and arrow. His less developed techniques consequently shut him out from a large supply of fish that is found in the area, and has limited fishing largely to the dry season, the months of July, August, September, and October, when the rivers and lakes are low and the waters are clear. At this time there is an abundance of fish in the low waters around the rapids, and these are caught either by shooting them with the bow and a barbed chonta-headed arrow or by stabbing them with an arrow.

Although I have seen some 15 edible varieties of tropical fish, the Siriono rarely attempt to catch more than four: catfish, bagre, bentones, and yeyú. Occasionally, one of the larger fishes, such as the pacú, is shot when feeding on chonta fruits that have dropped into a river or stream, but this is rare.

Around the edge of lakes, the usual method of catching fish is to wait in the overhanging branches of a wild fruit tree that is shedding fruit on which the fish are feeding. As the fish come up to eat the fruits, which either fall naturally into the water or are thrown in by the fisherman, they are shot with the barbed chonta-headed arrow and pinned to the bottom. Since the arrows are very long and the branches are low, the hunter to retrieve his catch merely reaches down and extracts the arrow, the fish being held by the barb. With patience and by occasionally changing his position a man can shoot as many as a dozen fish in a day by this method.

Another source of fish, and perhaps the principal one, are the small ponds and streams which fill up with water and fish in the rainy season but

which dry up in the dry season and offer the fish no means of escape. When the waters are drying, the fisherman walks through a pond catching the fish with his hands, stabbing them with an arrow, or hitting them on the head with a stick.

Although almost all of the Siriono today possess fishhooks, I rarely saw them actually used. Since they have no watercraft of any kind, it is impossible for them to reach the deep water where a fishhook would be of special advantage to them. Moreover, since they are not a river people, and since most of their camps are inland, fishing is not an important activity nor does it contribute much to the food supply.

COLLECTING

In the total economy, collecting ranks next to hunting in importance. This activity is participated in by both the men and women, and since much of the collecting is done by nuclear families, children get an early education in spotting and gathering edible products from the forest. Although women and children do considerable collecting while the men are off hunting in the forest, when it involves tree climbing they are always accompanied by the men. Now that iron tools have been introduced, many of the wild fruit trees of the area are being destroyed, because the natives find it easier to cut them down than to climb them when harvesting fruits.

Of all of the products collected, palm cabbage (*kišía*) is the most important. Practically all of the palms of the region yield an edible heart, but motacú is the most abundant and one of the easiest from which to extract the *kišía* (the tree is always cut down). It provides a constant source of vegetable food. This palm, moreover, produces a fruit (*yukúdi*) about the size of an egg, which grows in bunches, and which also forms an important staple in the diet the year around. When pickings are especially slim these two products, although not very nourishing, can always be relied upon to tide the Indians over until a more substantial diet can be obtained. As we shall see later, the importance of the palm cabbage is reflected in the magical aspect of the culture, its collection by women being occasionally preceded by a magical bloodletting rite.

Other palms, besides yielding a comestible heart the year around, also bear fruits which mature in a more seasonal cycle than the motacú. During

February, March, and April, the small red fruits of the chonta palm (*siriba*) are collected. At this season of the year the Indians also devote themselves to gathering the fruit of a palm not unlike the motacú which they call *hindoéra*. In extracting these fruits, which grow in bunches, the tree is climbed and the cluster pulled down.

During the months of July, August, and September there is an abundant harvest of the fruits of the samuque palm (*tiba*) and of the nuts of the cusi palm. These latter, which are usually collected on the ground after they have fallen from the trees, are one of the most nutritious wild foods found in this part of the Amazon Valley. The fruits of the assaí (*tibaéra*) and the totaí (*korondia*) palms, which are extensively used by the whites of the region for making wine, are not collected by the Siriono with whom I lived.

In addition to the above-mentioned palms, there are many other fruit-bearing trees which seasonally add their crops to the Siriono food supply. Predominant in the months of February, March, and April are the fruits of the coquino (*iba*), the aguái (*ibadiša*), the gargatéa (*dikišia*), pacáy (*iNga*), wapomo (*asambákwa*), pacobilla (*idayá*), cocáo (*ibíro*), balláu (*jičiba*), and paquió (*tibári*), as well as unidentified wild fruits which the Siriono call *mbéa*, *tikaría*, and *tarúma*. There is only one other fruit of any importance gathered in the dry season. This is an acid fruit known to the whites of the region as *mbís* and to the Siriono as *ndía*.

In collecting wild fruits the men climb the trees and throw them down to the women waiting below. This often entails considerable work as the trees are sometimes of such size that it is necessary to lash saplings to them in order to climb them, and it is frequently hazardous since a man is liable to fall from a branch while picking the fruits. If the fruits are not located too high in a tree, however, a man may fashion a rude hook by bending over and binding with liana the top end of a midrib of a motacú palm leaf, which can then be used to pull the fruits down from the tree. People usually eat their fill at the site of a fruit tree before loading their baskets to carry back to camp.

The digging of roots and plants and the grubbing of worms are almost negligible occupations among the Siriono, and provide hardly any part of the diet. The same may be said for the collect-

ing of insects, which was never done insofar as I observed. Certain varieties of shelled invertebrates—a mollusk called *urúkwa* and a mussel called *yisíta*—exist in the region, but these are likewise not sought for food, although their shells are gathered for tools. Several species of tortoise (*konómbi*) are extensively collected for food. These are highly prized, as they can be tied up and cooked when desired.

Like other tropical forest Indians the Siriono are fond of extracting the honey (*hidou*) of wild bees, which is the only "sweet" they possess. It is relished not only as food but for the making of mead as well. Honey is avidly sought, especially during the dry season when it is most abundant. In searching for honey, the Siriono do not go so far as to follow bees to the hive, but men out hunting, or collecting with the women, are most skillful in spotting wild beehives, which are usually located in hollow trees that are still standing. If the honey is not extracted when sighted, the person finding it returns later to do so.

In extracting honey the tree containing the hive may or may not be cut down. In any case, a hole is made—nowadays with an iron ax—below the spot where the honey is located. The combs are then removed with the hands and the honey wrung from them into calabashes. Before the introduction of iron tools, the hole where the bees entered the hive was enlarged by using fire and the chonta digging stick. The removal of a hive of wild honey often took as long as an entire day. Besides collecting the honey from the hive, the Indians save the beeswax, which is prepared for use as cement in arrow making.

AGRICULTURE

Although agriculture has been practiced for many years by the Siriono (they may originally have been a strictly nomadic people), it has never reached a sufficient degree of development to prevent their remaining a fairly mobile people. On the whole, its practice is subsidiary in the total economy to both hunting and collecting. One of the reasons for this may be that the game supply of an area becomes scarce before the rewards of agriculture can be reaped, thus entailing a migration of the band to other areas to search for game. Moreover, the sheer physical effort involved in adequately clearing a patch for planting is enor-

mous, as all labor of this kind is done with the digging stick and fire. Hence the Siriono have doubtless experienced greater rewards from the collecting of wild vegetable products and fruits, some of which, as we have seen, are available and abundant the year around, than they have from the practice of agriculture, whose yields are sporadic and uncertain.

At the time of my stay, the Siriono with whom I lived under aboriginal conditions were planting the following crops on a limited scale: maize (a soft red variety, unique in the area), sweet manioc, camotes, papaya, cotton, and tobacco. Here and there throughout the area of their wanderings, they have also planted calabash and uruku trees. According to one of my oldest and best informants, Embúta (Beard), both calabashes and tobacco had been introduced in his lifetime, which would be within the last 50 years. Of the other plants, however, he emphatically stated that his father had told him that they had been given to the tribe by Moon (the mythological hero) and were thus very old in Siriono culture.

No magical practice accompanies either the sowing or the harvesting of crops, and what planting is done is largely a family affair and not an activity in which all members of the band cooperatively participate. Both man and wife work jointly in clearing and burning over a small plot, frequently just outside of the house, in which they sow, also cooperatively, a few plants or seeds of maize, manioc, papaya, camotes, cotton, and tobacco. These plots are seldom over 50 feet square, and most of the work in them is done with the digging stick, the only agricultural tool. Today, of course, machetes are commonly employed in clearing a plot, but the digging stick is still extensively used in planting.

Little attention is paid to the time of year in sowing, although more sowing is done at the beginning of the rainy season than during the dry season, probably because the group is less mobile during wet weather. However, I saw maize, manioc, papaya, and tobacco planted the year around. Camotes, on the other hand, I saw planted only during March and April, these being harvested in July and August. Once plants are sown little attention is paid to them until harvest.

Although a more or less permanent Siriono hut is encircled by familial garden plots, by no means are all gardens planted just outside of the

hut. A hunter who is accustomed to going periodically to a certain lagoon, for example, to hunt or shoot fish, may plant a small garden there so as to have vegetable foods available when he returns on subsequent trips. I used to make hunting trips with my friend and informant, Erésa-cánta (Strong-eyes), and his five wives and children to a lagoon about 2 days' journey on foot south of Tibaera, where he had maintained garden plots for many years. These hunting parties, which frequently included his two brothers and his fathers-in-law and mothers-in-law and their families, would often last 2 weeks, during which time we would make our headquarters at his gardens. While the men hunted around the lake, the women would tend the few plants and gather what produce they had yielded. Other hunters maintained similar plots on other lakes and would frequently repair to them with their families to hunt, tend their gardens, and eat. Excess produce, such as a harvest of maize, is sometimes stored at the site in rude motacú baskets, so as to have a supply available on the next trip. Generally, however, little movement takes place until most of the crop has been eaten because of the difficulty of carrying it any great distance or the uncertainty of returning to the same spot for some time afterward.

ANIMAL HUSBANDRY

The Siriono possess no domesticated animals. Even the dog has not been introduced to the groups still wandering in the forest, although its existence is known through some individuals who have had contact with the outside. The general reaction to the dog, by those Indians who had had no contact with it, was one of extreme fear. This is not to be wondered at since the dog and the jaguar are called by the same term, *yikwa*. When I asked informants why the two were called by the same name, they invariably called my attention to the similarity between the footprint of a jaguar and that of the dog.

Although domestication is an art foreign to the Siriono, the young of various animals are sometimes captured alive and brought home as pets; under such conditions, however, I have rarely seen them live for more than a day or two, as they are very roughly handled by the children and are given no food. Consequently, they serve as morsels for some old man or woman for whom

pickings are slim. Generally, the young of animals are killed immediately after the mother is killed. I was told by informants at Casarabe that young animals were sometimes raised to adulthood and then killed for food, but while living with the less acculturated groups I never saw a single instance in which this occurred. When we were settled at Tibaera, for example, I myself tried to raise several howler monkeys, a coati, a young tapir, and a baby anteater—never, however, with any success, because they were soon killed and eaten by their Indian wards. These would then give me some such excuse for their dying as having been smothered by smoke in the night or having escaped into the forest. In all instances, I was

able to establish that they had been killed and eaten while I was absent.

WATER AND FUEL

There are plenty of rivers, lakes, and streams in the territory of the Siriono that contain a fresh supply of water the year around. Even when one is traveling through the bush during the height of the dry season one can usually find a water hole, a stream, or a brook from which to drink. Camp sites are always located near these spots. No wells are ever dug.

There is likewise no shortage of firewood. The forest is full of dead and rotten trees that make excellent fuel.

FOOD AND DRINK

Two of the most frequent expressions that one hears around a Siriono shelter are: "*šediákwa túti*" ("My stomach is very empty") and "*ma nde šeri*" ("Give me something"). To the latter may be added an appeal for some delicacy, such as a piece of tapir or peccary meat, a bit of wild bee honey, or whatever else to eat someone may have around. But since the attention of the Siriono is most frequently and forcibly focused on his stomach, requests for anything but food are rare. Not infrequently the unlucky hunter, while resting from an unsuccessful chase, is reproached by his wife for not having brought home more game, and, invariably, as one leaves for the hunt, the women and children call after him such commands as "Bring me back the leg of a peccary" or "Bring me back some tapir meat."

DIET

The environmental and cultural conditions which exist among the Siriono are most favorable for giving rise to a strong anxiety about questions of food. It would seem, in fact, that of all the basic drives demanding satisfaction for survival, hunger is the one most frequently frustrated. The supply of food is rarely abundant and always insecure. Game is not plentiful; the techniques of hunting, fishing, and agriculture are very limited; patterns of food storage do not exist. Consequently, eating habits depend largely upon quantities of food available for consumption at the moment. When food is plentiful people eat to excess and do little else; when it is scarce they

go hungry while looking for something more to eat. Starvation, however, never occurs. There are times when the Indians go for days on a diet of motacú fruits and palm cabbage, but these seem to be adequate for subsistence until game can be hunted. I know of one instance in which a party of Indians survived for 18 or 20 days on a diet of nothing more than palm cabbage and a few wild fruits collected from the forest. Since they were on the march during this time, and were thus using up a great deal of energy, they exhibited definite signs of undernourishment after their journey.

While I was living at Tibaera, my attention was called one afternoon to the arrival of seven Indians (two men, two women, and three children) who appeared to be especially thin and emaciated. After giving them some food, I inquired as to the reason for their semistarved condition. One of the men told me that they had run away from the Government School at Casarabe, situated about a hundred miles east through an uninhabited forest and plain that contained no trails, and that they had been without food for "many" days. This struck me as strange, inasmuch as the men were carrying their bows and arrows and the lands through which they had come were known to contain considerable game, including wild cattle which occasionally stray from the herds that wander on the plains of Mojos. Their hunger, it turned out, resulted not from the lack of game but from a lack of fire. After leaving the school, they marched at a rapid

pace for a day or two to escape pursuit, after which they became so fatigued that while they were sleeping heavily one night their fires became extinguished. Since the Siriono have lost the art of making fire, and will not eat raw game under any conditions, this party was left with the alternative either of returning to the school and being severely punished for running away or of striking out in the direction of settlements which they knew to exist on the Rio Blanco and being rewarded by obtaining fire and freedom. While making the journey to Tibaera, they were reduced to a diet of a few plants and wild fruits which they found along the way, and because of the young children they were considerably impeded in their progress. Thus the journey, which would normally take about 6 to 8 days to complete on a full diet, lengthened to a period of 18 or 20 days because of the meager diet on which they were forced to exist. One of the men told me that if they had not arrived when they did they might well have starved to death.

Circumstances like those just mentioned rarely occur, but it is not uncommon for the Siriono to go for several days at a time without eating meat. My notes are full of statements to the effect that there was no meat in camp for periods of 2 or 3 days, and when I myself was on the march with the Indians, I passed, in common with my companions, many meatless days. The longest of such periods that I recall endured for 4 days, during which time we were reduced to a diet of cusi nuts, palm cabbage, and motacú fruits. At this time we were wandering through a particularly sterile piece of high ground on which no game was sighted. When we finally did run across a band of wild peccary late one afternoon, we were all so fatigued that we were unable to give adequate chase and thus bagged only about half as many animals as we might have killed under more favorable conditions.

While first living at Tibaera, I kept records of the amount of game hunted and consumed by the band for a period of 3 months—during August, September, and October, 1941. At this time there were about 50 adults living there, and no meat was being introduced from the outside. During August and most of October I kept the records myself, but during September and the first 8 days of October I was wandering with another group of Indians in the forest, and the

records were kept by a Bolivian employee of mine who stayed at Tibaera. The daily amount of meat hunted, by whom secured, and the approximate quantity, i. e., estimated gross weight, were noted. The exact distribution of the meat to each individual was impossible to record, but the distribution outside of the extended family was noted when it occurred. On the basis of the total population, the approximate consumption of meat per individual per day is shown in the following tabulation:

Month (1941):	<i>Meat</i> (in pounds)
August.....	0. 56
September.....	. 53
October.....	. 36

After my return from the forest in early October I was accompanied by 94 more Indians, so that keeping records of the amount of meat hunted and consumed by the entire group became so complicated and time-consuming that I was forced to abandon it. However, the figures above give a rough estimate of the quantities of meat consumed daily by the average Siriono. The noticeable decrease for the month of October was probably due to the fact that the Indians were more active in clearing land—to be planted in the month of November—than in hunting. Although I have no reliable data on meat consumption for the other months of the year, it is probably less during January, February, March, and April than at other times, because of the difficulty of travel during the rainy season.

The figures above represent the amount of meat hunted by the Indians with bows and arrows. The data, of course, are not strictly accurate, because the weight of the meat had to be estimated and the number of people present in camp was not always the same. During this period some hunters would be gone for 3 or 4 days at a time, when it was impossible to keep records of their catch, and on some days perhaps not all of the catch was recorded. But even allowing for a large margin of error, the average Indian probably eats less than a pound of meat per day.

During August there was no meat in camp for 11 days; in September for 9 days; in October for 12 days. The most persistent hunter was out for 16 of the 31 days in August, 12 of the 30 days in September, and 19 of the 31 days in October. The majority of hunters averaged from 10 to 12

days a month. To be sure, the conditions at Tibaera were not in all respects aboriginal. Informants told me, however, and my observations under aboriginal conditions seem to bear them out, that a man goes hunting on the average of every other day throughout the year. On the odd days he rests, repairs arrows, eats (if he has any food), etc.

While I was wandering in the forest with a group of Indians, when I too was hunting with a rifle and shotgun, the amount of meat consumed by the group rose considerably. I have records on this only for September 1941, a large part of which I spent on the march with parts of two extended families of Indians (21 adults in all) and one Bolivian companion in search of another band. During the first 11 days of the march, when most of the hunting was done with the rifle and shotgun, our meat consumption averaged 2.2 pounds per individual per day. After we had rested several days with another band and continued the march, our meat consumption jumped to 4.1 pounds per day for the last 15 days. I am inclined to believe that the increase was largely due to the fact that with a rifle and shotgun we were able to bag more big game, like tapirs, alligators, and peccaries, than the Indians would have been able to kill with their bows and arrows. Part of the increase, of course, may have resulted from the fact that we were wandering in areas richer in game than most and that we were hunting every day, but the superiority of the rifle over the bow and arrow was almost certainly a factor. When game was sighted, the Indians would almost always call on my Bolivian companion or me to shoot.

Although meat is the most desired item in the diet of the Indians, it is by no means the most abundant. Maize, sweet manioc, and camotes (when available) constitute a very important part of the food supply. Maize is eaten especially during the months of February and March. By the end of March the supply of maize, except for the few large ears that are saved for seed, has generally been exhausted. Sometimes, though rarely, maize is replanted in May to be eaten in July and August. Manioc, once planted, takes from 8 months to a year to mature. These restless natives seldom sow fields of any size, since they will often not be on hand to reap the benefits. Frequently in the Siriono territory one runs across old gardens containing edible stands of manioc

that had been abandoned before the product was mature. When available, however, manioc is eaten the year around. Camotes constitute a heavy part of the diet during July, August, and September. The supply is never great, however, and is usually exhausted soon after the harvest. Papayas are generally available in small quantities the year around because the plant readily grows wherever seeds are dropped. The Indians seldom plant papayas. From their habit of swallowing the seeds of the ripe fruit, new plants automatically spring up after the seeds are expelled in the excrement. The area surrounding an Indian hut is thus rich in papaya trees.

Supplementing the diet of meat and agricultural products are numerous varieties of wild fruits already referred to which mature during January, February, and March. These, coupled with maize, supply sufficient food for the semisedentary rainy season, when the meat supply is reduced.

Food seems to be scarcest at the end of the rainy season (May and June), when there are few available wild fruits and when the waters are still too high to allow extensive migration. It is also scarce at the beginning of the rainy season (November and December) before the maturity of wild fruits and agricultural products.

FOOD TABOOS

With the exception of snakes and insects, almost everything edible in the environment contributes to the food supply. The reason for not eating snake meat, however, does not rest on magical or religious grounds; the Siriono believe, since a snake is able to kill by poison, that anyone who eats snake meat is also apt to be poisoned. This taboo applies not only to all poisonous snakes, such as the bushmaster and the rattler, but is generalized to include even nonpoisonous anacondas, which often reach a length of 20 feet and could contribute considerable meat to the food supply.

I was presented with two favorable opportunities to break down the taboo on snake meat, but in both cases the experiments failed. In the first instance, I killed a bushmaster about 8 feet in length just outside of the house. Since I was badly in need of a waterproof pouch in which to carry my powder and shot, I decided to remove the hide and to try to make one. While skinning

the reptile, I noticed that it was particularly fat, and since I had no oil with which to keep my arms greased I decided to fry down some snake fat for this purpose. Also, since I had never had the opportunity, I decided to taste some of the meat. I made a point of frying a large steak in front of the Indians so that they could readily observe everything that was going on, and after this was done I sat down in a hammock and ate it in full view of the chief, who had not only warned me not to eat it but who, I am sure, expected me to drop dead at any moment. Fortunately, no ill effects resulted. On the following day I ate some more, but though I tried my best, I was unable to get a single Indian to try a piece of the meat. Some days later I had occasion to bake some corn muffins, and since I had no lard at the time I decided to make them with snake grease. After they were done the chief came around, and I offered him one. He began contentedly to munch it. After he had eaten about half, I could not resist the temptation to tell him that the muffins contained snake fat, whereupon he immediately jumped out of the hammock, put his finger down his throat, and threw up every bit of the muffin he had eaten. For weeks afterward he reminded me of the trick I had played upon him and was skeptical of eating any food that I offered him until he was certain that the snake fat was gone.

On the second occasion, my Bolivian companion, Silva, killed an anaconda of about 20 feet in length. Conditions for introducing snake meat at the time were favorable since little game had been secured for several days. But even under these circumstances, although I myself again set the example, I was unable to convince my Indian companions to try it. They showed no compunction, however, about either hunting or eating the buzzards which fed on the carcass of the snake, and for several days thereafter buzzard became a prominent part of their diet.

Apart from snake meat, bats, and a few poisonous insects there are few things the Indians refrain from eating. Although not constituting a prominent part of the diet, such things as head lice, wood ticks, and grubs are swallowed without compunction.

Theoretically, a man is not supposed to eat the flesh of an animal which he kills himself. If a hunter violates this taboo, it is believed that the

animal which he has eaten will not return to be hunted by him again. Continued breaches of this taboo are consequently supposed to be followed automatically by the sanction of ill-luck in hunting. This rule may formerly have been an effective mechanism by means of which to force reciprocity in the matter of game distribution, but if so, it has certainly lost its function today, for the disparity between the rule and its practice is very great indeed. Few hunters pay any attention to the rule at all, and when they do it is only with respect to larger animals, such as the tapir and the harpy eagle, that are rarely bagged anyway. In the case of smaller animals, such as coati and monkeys, I never saw hunters show any reluctance to eating those that they had killed themselves. Embúta, one of my older informants, told me that when he was a boy he never used to eat any of the game that he killed, but that nowadays the custom had changed and that it was no longer possible to expect meat from someone else who hunted it. It thus seems that through a gradual process of change hunters have discovered that eating their own game does not necessarily result in poorer luck in hunting but, rather, in greater satisfaction to the hunger drive. The reinforcing experience of eating one's own game has thus caused a partial break-down in an old tribal custom.

The few food taboos that do prevail among the Siriono have almost exclusive reference to the animal world. Agricultural products and wild foods collected from the forest are never taboo; they can be eaten on all occasions, by all age groups, and by both sexes. Free of all food taboos, including certain kinds of meat which are forbidden to others, are the aged, that is, those who have passed child-bearing age or possess grown children. Since the Siriono do not practice fasting of any kind, even ceremonially, the aged can thus eat anything at any time.

There are, in fact, certain meat foods that are supposed to be eaten only by the aged. These include the harpy eagle, the anteater, the owl monkey, and the howler monkey. Since the aged usually get only the left-overs of other food, the society thus seems to have provided for them in some way by reserving these animals exclusively for their use. Under conditions of need, however, I have frequently seen them eaten by people who were not supposed to eat them; only when

other animals are relatively plentiful are the taboos strictly observed.

Apart from the above-mentioned food taboos there are few others. Since these latter will be discussed on the occasions when they prevail they will not be mentioned here.

PRESERVATION AND STORAGE OF FOOD

The preservation of food is almost unknown. In this tropical climate fresh meat must be cooked within 8 hours after it is killed in order to prevent spoilage. The Siriono, moreover, have no salt with which to preserve meat, nor have they developed any techniques of drying and smoking meat to render it edible for more than 2 or 3 days. Considering the rude methods by which game is bagged, of course, the catch is rarely so large that it cannot be easily consumed within a day or two. If, however, the amount of game is greater than can be immediately eaten, the excess meat is left lying on a low platform under which a fire is kept smouldering to preserve it. It thus remains edible for about 3 days. But since no hunting takes place when one has meat on hand, the immediate surplus is never replenished. Hence even under the best of conditions the Indians can never be sure of possessing a meat supply for more than the 3 days that it can be preserved by their crude methods.

Foresight in another respect does exist. On hunting and gathering trips the Siriono like especially to encounter tortoises, because these can be collected and preserved alive over considerable periods of time. Tortoises are relatively abundant in the environment, and a lucky hunter may sometimes return with as many as 8 or 10 of them, each of which may weigh from 8 to 10 pounds. They can be tied up with liana and kept alive for about a week, thus insuring a man and his family a meat supply for as long a time. In instances of this kind, one or two tortoises are usually butchered each day. In the meantime the hunter spends his time eating and loafing and does not go out on the hunt again until the supply is exhausted. I have seen hunters who, under these conditions, rarely moved from their hammocks for an entire week.

Maize is the only agricultural product that is ever stored in any quantity. Immediately after each harvest the various families tie their surplus ears of maize (in the husk) on to poles in the shelter. At this time a few of the larger ears are

selected and put away in a basket for seed; the rest are gradually eaten until the supply is exhausted. Since crops are never very large, the surplus quantity of maize rarely lasts for more than a month after harvest. Thus, although two crops may be planted by a family during the year, maize is actually eaten in abundance for only about 2 months, that is, for about a month following each harvest.

Manioc and camotes also are not stored, nor is the former made into flour. Both manioc and camotes are dug from the ground and eaten as they mature. When manioc is extracted, a few of the tubers may be planted at the same time so as to have some plants constantly maturing, but under aboriginal conditions the supply of both manioc and camotes, like that of maize, is never very abundant, and when the crop is mature it is quickly exhausted. It is a rare family that has manioc to eat the year around (I never knew of one), or camotes to eat for more than a month or two after the harvest.

Wild fruits and other edible forest products are likewise never preserved or stored. Once the season of wild foods has passed they are not eaten again until the next season comes around.

With respect to the food supply in general it can be said that, except for certain agricultural products like manioc, maize, and camotes, reserves for more than 2 or 3 days are never built up. Fortunately the environment offers a constant source of some foods, like palm cabbage, so that even though hunger is often intense starvation is never imminent.

PREPARATION OF FOOD

Little care is taken in dressing game, which is done either by men or women. Animals with hair, such as monkeys and peccaries, are first singed whole in the fire, and the burned hair is then scraped off with the fingernails or with a small section of a midrib of a motacú palm leaf. The animal is then gutted with a sharp piece of bamboo after which the whole carcass is sometimes (but by no means always) perfunctorily washed before it is cooked. Birds are hastily plucked and then singed in the fire and gutted. If an animal is small it is usually cooked whole, but if it is too large for a pot (or too large to roast rapidly) it is quartered or cut up into smaller

pieces with a bamboo knife. Armored animals like the armadillo and tortoise are usually thrown in the fire and left there to roast in their shells. Fish are never gutted before they are cooked, nor are the scales removed.

The division of labor as regards cooking varies a great deal, depending upon the circumstances under which the food is being prepared. Everyone knows how to cook, even young children.

Cooking is an art learned very early in life. When traveling with his mother and father, a child is often given a cob of corn to roast, some motacú fruits to roast, or a morsel of viscera to cook for himself. In fact, whenever animals are being cut up, there are always young children (as often boys as girls) around, waiting for some tidbit, which they then take to a fire and roast for themselves. Such morsels they share with no one else.

While in camp, when the group is fairly settled, most of the cooking is done by the women. This is especially true if the preparation of the meal involves the grinding of maize or other vegetable products that are sometimes mixed with the meat and cooked in a pot. On the march, however, when pots have been temporarily stored and when most of the food is roasted, the men take as active part in cooking as the women. In fact, the roasting of meat often falls entirely to the men, especially since they may be off on the hunt several days without the women and thus be forced to barbecue the game before returning to camp.

No condiments of any kind are used in cooking. Even salt (no deposits of this product are found in the area) is unknown to the Siriono living under aboriginal conditions. Evidently the foods they eat contain enough salt to produce the hydrochloric acid necessary for digestion.

I introduced salt to some Indians for the first time, and they expressed a distaste for eating it. By using small quantities in cooking, however, they soon developed a craving for it. In some instances this craving (once the Indians have become accustomed to using salt) has become so great as to become an important factor in establishing and maintaining friendly relations with the whites. The late Frederick Park Richards, an American cattle rancher living near El Carmen,

who was one of the first white men to establish permanent relations with the Siriono in the Rio Blanco area, told me that when he first came to the region in 1912 he was able to maintain peaceful relations with the Indians for years before they permanently settled down with him on his farms in 1925 by conditioning them to eating salt. I myself, however, have traveled with primitive groups when all of us went without salt for as long as 43 days without suffering any apparent ill effects from such a diet.

Actually, little emphasis is placed on the preparation of food. Depending upon the time, place, type, and quantity of game, it may be roasted or baked in the ashes of the fire, broiled on a spit or babrecot, or boiled or steamed in a clay pot. Some vegetable foods, such as maize, are prepared by grinding before they are cooked, and, of course, many nuts and fruits are eaten raw.

The following is a list of foods and the ways they are prepared.

Foods:

Meats.....	Never eaten raw; always broiled, roasted, or boiled; sometimes boiled with maize, manioc, or camotes.
Fish.....	Never eaten raw; almost always roasted on babrecot with scales and guts; sometimes boiled.
Maize.....	Never eaten raw; roasted in husk when young and tender; roasted on cob when mature and hard; sometimes ground up and boiled with meat or made into corn-meal cakes.
Manioc.....	Never eaten raw; peeled and boiled, sometimes with meat; roasted in peel in hot ashes.
Camotes.....	Never eaten raw; boiled in peels, sometimes with meat; usually roasted with peels in hot ashes.
Papaya.....	Always eaten raw.
Palm cabbage.....	Eaten raw but frequently boiled with meat.
Motacú fruit.....	Never eaten raw; always roasted.
Nuts.....	Always eaten raw.
Coquino fruit.....	Do.
Chonta fruit.....	Always boiled.
Aguaí fruit.....	Always roasted.
Híndoéra fruit.....	Do.
Gargatéa fruit.....	Do.
Pacáy fruit.....	Always eaten raw.
Cacáo fruit.....	Do.
Ndía fruit.....	Do.

EATING

It is difficult to establish a schedule of meal hours among the Siriono because of the insecure nature of the food supply and the nomadic character of life. People eat when they have food, and under these conditions they are just as apt to eat during the night as during the day. In fact, more food is consumed at night than at any other time because hunters and collectors are away from camp most of the day and for reasons which we shall examine in a moment.

The principal meal is always taken in the late afternoon or early evening. Other eating is mainly of the between-meal type, and occurs at all hours of the day or night. I was constantly surprised to find, throughout my residence among the Siriono, that food which had been left over from an evening meal was invariably gone by morning. Frequently, moreover, after the evening meal has been eaten, a pot of food is put on the fire to cook during the night, and this, too, has usually disappeared by morning.

The habit of eating during the night grows not only out of the necessity of hunting and collecting during most of the day but also out of a reluctance to share food with others. When meals are taken during the day, a crowd of nonfamily members always gathers to beg for morsels, and though little attention is usually paid to them, they do, nevertheless, constitute an annoyance. By eating at odd hours during the night, when nearly everyone else is asleep, an Indian not only gets more food but also avoids the nuisance of having others around to beg it from him. While I was on the march with the Siriono, my Bolivian companion and I were forced to follow the same practice. We found that it was impossible to eat in peace during the day, because we were constantly hounded by children and adults who claimed that they were hungry. The fact that we, too, had not eaten made no impression on them. Consequently we ate the greatest portion of our food at about midnight, when almost everyone else was asleep. A few of my loyal Indian companions, who developed a certain interest in my welfare, used frequently to wake me in the middle of the night to share food which they hated to display during the daytime because of the possibility of their having to divide it with someone else. When we were settled—I then sometimes had a supply

of certain foods—it used to amuse me to note how my Indian friends would suggest that they come to my house and eat at night when the others would be fast asleep.

Strictly speaking, the Siriono possess no eating utensils. A broken calabash may sometimes be used to scoop food from a pot or even to eat from, but such utensils as plates and spoons are not manufactured. Generally speaking, everyone participating in a meal eats from a common pot. Chunks of meat, pieces of manioc, and the like are picked out of the pot with the hands, but when the meal consists of gruel or a soup the food is generally scooped out of the pot by using half-shells of motacú fruits as spoons. Food is also sometimes distributed for consumption by pouring it out on leaves of patujú, a plant resembling the banana. The distribution of food rarely goes outside of the extended family. Within the extended family, however, the distribution of food does not follow any strict pattern. Each nuclear family cooks its own food and the head of the house usually gets the back of an animal; his first wife the two hind legs. Other parts of an animal are usually distributed without reference to status within the family.

Eating takes place without benefit of etiquette or ceremony. Food is bolted as rapidly as possible, and when a person is eating he never looks up from his food until he has finished, so as to avoid the stares of begging onlookers. The principal goal of eating seems thus to be the swallowing of the greatest quantity of food in the shortest possible time.

Appetites for particular foods are few. There is a preference for meat over all other foods and a preference for fat meat over lean meat, but the cook book of the Siriono is almost devoid of recipes. I have seen a man eat hawk with as much gusto as partridge, and I never heard an informant speak disparagingly about any food regarded as edible by the Siriono.

The quantities of food eaten on occasions are formidable. It is not uncommon for four people to eat a peccary of 60 pounds at a single sitting. When meat is abundant, a man may consume as much as 30 pounds within 24 hours. On one occasion, when I was present, two men ate six spider monkeys, weighing from 10 to 15 pounds apiece, in a single day, and complained of being hungry that night.

NARCOTICS

The only narcotic used by the Siriono is tobacco (*éro*), which is smoked in clay pipes, whose manufacture has already been discussed. Both the men and the women smoke, although it is always the latter who make the pipes (*keákwa*) and prepare the tobacco. Children do not smoke until after they have reached the age of puberty.

Just when the Siriono adopted tobacco is not known, although it certainly does not seem to have been aboriginal with them. As already mentioned, one of my oldest informants said that it was received from the whites while he was still a child, which would date its adoption by this particular group of Siriono at some time within the last 60 or 70 years. (The literature tells us nothing on this point.) Other informants at Casarabe, however, told me that when there was no tobacco available other leaves were smoked, but what these were I was never able to determine. The forest Siriono with whom I lived at Tibaera saved seed and planted tobacco regularly with the rest of their crops, and they smoked no other kind of leaf. Wild tobacco, moreover, does not grow in the area.

After the leaves of tobacco have become mature they are picked by the women and are slowly dried on a small mat, made from the heart leaves of the motacú palm, which is placed on supports over the fire. Once dried the leaves are powdered in the hands and the tobacco is ready for smoking. The supply of powdered tobacco is stored in a small calabash, which is topped with a piece of corncob.

All smoking is done in the house. It is considered bad form to smoke while on the hunt, as it is believed that animals will be driven away by the smell. Most smoking thus takes place while the Siriono are resting in the hammock or having drinking feasts, and hunters almost always smoke immediately after returning from the forest to stave off hunger until they are given some food.

The pipe is filled and lighted by placing a small live coal on top of the tobacco. The pipe is grasped by the stem (the bowl gets very hot) with either the right or the left hand. When smoking, the head is slightly tilted back, since the pipe stem protrudes downward from the bowl. The smoke is sucked into the mouth only (no inhalation) and is blown out in short rapid puffs by

withdrawing the pipe and extending the lips. When there are several people around, the pipe is passed from one to another. When the pipe ceases to draw well, it is cleansed with a straw from a heart leaf of a motacú palm.

The Siriono do not seem to be much addicted to the use of tobacco. However, its role in the drinking feast is important in aiding the participants to arrive at a semidrugged or partially intoxicated condition. During the drinking feasts for women I often heard them singing impromptu songs about pipes and tobacco which indicates that this drug may have some further magical significance that I was unable to ascertain. Tobacco, however, is never used therapeutically.

DRINKING

Since the Siriono wear no clothes, and consequently perspire little, they are able to withstand long periods of time without water. Thirst, moreover, is almost never a problem to them, because wherever they wander they can find water holes or streams from which to drink, and if one cannot be found there are almost always lianas and stems of plants from which a considerable water supply can be obtained. Consequently the Indians rarely carry water with them when they are on the march.

At camp sites, water is brought to the house by women or children in calabashes or in sections of bamboo, which also serve as drinking vessels. If a thirsty Indian comes upon a water hole while in the forest, he plucks a leaf of *patujú* to drink from. In doing this once in the company of Kénda, one of my youthful informants from Casarabe, I inadvertently dropped my leaf into the water when I had finished drinking. He snatched it up and threw it away in the forest, saying that the leaf of the *patujú* contained an evil spirit and that if one threw his leaf into the water after drinking one would become sick. Although the ideas about water and thirst have not been crystallized to a point where I was able to get much information about them, I did observe that all Siriono followed this practice when drinking from holes in the forest.

Accompanying the frustrations of forest life are occasional drinking bouts, which vary in frequency with the quantity of wild bee honey available. Since this product is most abundant in the dry season—after the flowering of the plants and

trees—most of them thus occur during the months of August, September, October, and November.

Mead is made from a mixture of cooked corn meal (or cooked manioc or cooked camotes), water, and wild bee honey. It is always made by the women. The maize is first ground up fine in a mortar. The corn meal is then mixed with water and boiled in a clay pot until it becomes thick gruel. The hot gruel (not masticated as by many South American Indians) is then emptied into calabashes (containing only a small round hole at the top), each of which is about half-filled with cold water, until they are filled to about four-fifths of their capacity. After the gruel and the water have been thoroughly mixed with a small stick, about half a cup of wild honey for each quart of mixture is added to the calabashes. The honey is then stirred into the mixture, and the holes of the calabashes are loosely stopped with leaves of patujú to keep out flies and to allow some air for fermentation. The calabashes are then stored (undisturbed) in hanging baskets for about 3 days, when the brew is considered to be of sufficient force (about the strength of beer) to be drunk.

In making other types of beer the same process is followed, the only difference being that manioc (or camotes) is substituted for maize in making the gruel. To increase the strength of the beer, to make it more nourishing, and to hasten the fermentation process, boiled or baked corn-meal cakes are sometimes added to the brew.

Calabashes are considered to be the most suitable type of vessel for fermenting native beer, although when there was a shortage of these vessels I observed that it was fermented in long sections of bamboo.

The making of mead is accompanied by considerable excitement and bustle. Great care is taken to see that the mixture turns out all right. There are always plenty of children present hoping to get a bit of the honey, and the women usually do not lack helpers, since jealous neighbors, generally uncooperative, offer their services in the hope that they too will get a chance to partake of the honey while the mead is being made. More often than not they are brushed off and return to their hammocks unrewarded.

Drinking bouts usually start informally. The man possessing the liquor invites a number of his male relatives to join him in consuming what beer he may have on hand. Bouts generally start in

the afternoon, and, depending upon the quantity of liquor available, may last until far into the night or even be continued on the following day. The participants squat in a circle near the host's hammock, and as a calabash of mead is passed around, each in his turn drinks heavy draughts before passing it to the next person in the circle. The drinking is always accompanied by continual smoking of clay pipes (also passed around the circle), which ultimately contributes as much or more to the resulting intoxicated or drugged condition as does the somewhat light and nourishing native beer.

As a drinking feast progresses, the Siriono, who is a very uncommunicative fellow when sober, becomes an animated conversationalist, a performer, and a braggart. At the opening of the bout the talk usually turns to the merits of the liquor. One of my more poetic informants, Erésá-eánta (Strong-eyes), used to say, in describing the liquor at the start of almost every drinking feast: "Yesterday it was without force, like water or like earth, but today it has great strength." As the effects of the drinking and the smoking begin to be felt, one or more of the participants breaks out in song, usually impromptu and related to some exploit of which he is particularly proud, such as the killing of a tapir or a harpy eagle. Another may be engaged in discussing the desirability of looking for a new wife (always a young one or *yukwáki*) or of casting out the shrew he now has. As the mood gets mellow everyone joins the singing, and when the party has reached an advanced stage almost everyone is singing a different tune at the same time.

While attending these drinking feasts, I tried my best to record a number of these songs, but I was never able to set down more than snatches of them because of the bedlam and the darkness existing at the time. Moreover, since most of the participants, following a drinking bout, were victims of alcoholic amnesia, brutal hangovers, and high anxieties, it was impossible to get much cooperation from them in this matter later.

At every drinking feast of any size most of the nonparticipating members of the group are assembled at the edge of the circle. The spectators amuse themselves listening to the songs and the conversation, commenting on the course of the feast, and waiting for the participants to get drunk enough so that they can sneak a drink now and

then. Children are always present, eagerly awaiting the emptying of a calabash, since it is then passed to them to drain the dregs. The women are almost always in the background watching over their husbands, because they are quite certain from previous experience that the party will end in a brawl. This is always the case when there is sufficient liquor. A man deep in his cups will turn to another (it may be his brother, uncle, his son-in-law, or even his father-in-law) and insult him with some such phrase as "*Etómi túti nde*" ("You are very lazy") or "*Ai í tendé gátu*" ("You never bring me meat with any fat on it"). He will be answered in the same vein, and a fight will soon break out. The Siriono do not fight with their fists at this time; physical aggression is expressed in the form of a wrestling match, in which one participant tries to throw the other to the ground again and again until he is too exhausted to rise. Since the contestants are usually so drunk that they cannot stand up, these wrestling matches frequently terminate with both of them passed out on the floor much to the merriment of the spectators. Not infrequently, however, one or the other (or both) falls into one of the innumerable fires in every Siriono hut and gets badly burned.

When the party reaches the fighting stage the crying women intervene and try to stop the fights. At this time they too come in for their share of aggression and not infrequently are struck forcibly by their husbands. However, I heard of only one case in which a man murdered his wife in one of these drinking bouts. This happened approximately 15 years ago, the wife being shot through the heart with an arrow. Although overt aggression runs high during drinking feasts, after they are over the participants usually suppress their angry feelings within a few days' time, and all is normal again until another drinking bout takes place. Insofar as I observed little sexual activity takes place during or immediately after drinking feasts. Participants are usually too drunk to indulge in sex.

When a considerable supply of honey is available, drinking bouts are timed so as to take place every few days until all the liquor is gone. For lack of honey, however, not more than a dozen are likely to occur during the year. A man who has given a feast expects to be invited to and is expected (wants) to attend those given by the people who participated in his. As most of the

people who take part in these feasts are near relatives, this almost always happens.

In only one instance did I notice that the aggressions of the drinking feasts were the direct cause of strained relations for a long period of time. During a bout in August 1941, Eantádu (Father-of-Strong-one), a chief, insulted and wrestled when drunk with Erésá-eánta (Strong-eyes), his cousin, or father's sister's son, over questions of food. Eantádu when drunk told Erésá-eánta that he never brought him any food, that he never hunted spider monkeys, that he was lazy, that he was evil, etc. Although neither participant knew much about what he was doing, a wrestling match ensued in which Erésá-eánta got badly burned in the fire, and he was unable to get out of his hammock for several days. As a result of this fight, about which Erésá-eánta was later told by his wives and brothers, strained relations persisted until January 1942, when I first saw the two together again at a drinking feast given by Eantádu—one which, incidentally, did not end in a brawl, as the liquor ran out. After recovering from the first drinking feast, Erésá-eánta with a couple of his brothers and their families remained away from the band for long periods of time, hunting, fishing, collecting, and attending their gardens at a nearby lake. Although the party returned to Tibaera from time to time for a few days or a week, Erésá-eánta would have no relations whatever with Eantádu, even though their respective wives were friendly enough. After relations had been reestablished at the second drinking feast, however, the two continued on friendly terms.

Like the men, the women too have their drinking feasts, but these do not usually terminate as roughly as those of the men. In five of these feasts which I observed, singing was the prominent feature apart from the drinking and smoking. Although the women accused each other of having had sexual relations with one another's husbands, most of them had reached such an intoxicated condition by the time these accusations were made that they were placed in their hammocks to sleep it off.

In only one instance did I observe mixed drinking. This involved three old women and their husbands and brothers. On this occasion, however, only a few calabashes of mead were available, and the party was not organized in any way.

ROUTINE ACTIVITIES OF LIFE

DAILY ROUND

"Early to bed and early to rise" is the motto of the Siriono, who usually retire to their hammocks as soon as night falls and who are up and about before the crack of dawn. Actually their day begins a couple of hours before dawn. Retiring as they do about 7 or 8 o'clock in the evening, they are generally awake by 3 a. m., when they begin to sing impromptu songs as they engage in the routine of roasting a cob of maize, a piece of manioc, or some camotes, or of warming up a pot of food left over from the night before. Such activity is continued until daylight, by which time they have eaten and the day's work has begun.

In the early morning a Siriono hut must be approached with caution so as to avoid stepping on the innumerable piles of excreta that have been freshly deposited just outside of the house during the night. Although adults retire to a respectable distance from the house to defecate during the day—there are no special latrines—their nightly behavior in this respect is restricted by the intense darkness, the annoyance of insect pests, and the fear of evil spirits, and they seldom go very far from the house. Moreover, the excreta are rarely removed the following day, but are left to gather flies, to dry up, or to be washed away by the rain. Thus after a few weeks' time the immediate environs of the house become rather unbearable to the unaccustomed. The only care taken in this respect is to avoid defecating directly in the house, on the trails leading out from the house, or within about 10 yards of a water hole.

The activities of the day begin with little ceremony. Such health and cleanliness measures as washing the teeth, face, or hands, or combing the hair, at such an early hour of the morning, are quite unknown to the Siriono. True, one may go to the hole or a brook for water early in the morning, but it will be used for drinking or cooking. Moreover, at this time of day almost no attention is paid to one's neighbor. This is clearly reflected in the native language, which contains no such salutations as "Good morning" or "Good night," and it is rare to ask a neighbor how he slept the night before or to inquire of a sick relative whether he has improved during the night. Most early morning preoccupations, in fact, revolve around the happenings in one's immediate family, within

which, however, neither loud conversation nor squalling children ever seem to be lacking. Especially are complaints registered: one may have been bothered by mosquitoes the night before; another may have been bitten by a vampire bat; a third may have burned himself, having fallen out of his hammock into the fire during a night-mare.

On a typical day, when settled or on the march, the men are off to hunt at the break of day. If they have not had time to eat before they leave, they may take with them a piece of roast meat, maize, or manioc, to munch as they go along the trail. When men remain at home, they usually occupy themselves in repairing arrows, making bows and digging sticks, etc. If the band is fairly settled at the time, the men hunt in all directions from the house, but if the group is on the march, the hunters usually proceed in a circuitous route through the forest in the direction of the camping spot decided upon for that night. In any case the women are usually left behind to care for the children and to carry out the routine household duties or, if on the march, to pack up the gear and transport it to the next camping spot. As camps are rarely moved during the rainy season, and not more often than every 10 days or so during the dry season, a partial stability is maintained over considerable periods of time.

While the men are out hunting, the women may be occupied in any number of routine household tasks, such as bringing in firewood, grinding corn, cooking, weaving baskets or mats, coiling pots, drying tobacco, or repairing hammocks. The women also devote a considerable part of the average day to the spinning of cotton string, which is extensively used in arrow making. Since most of these household duties are pursued around the hammock and the fire, gossip and conversation are freely indulged in throughout the day, and there is almost always a pot of something cooking on the fire with which the women and children nourish themselves while the men are gone.

The men usually return from the hunt between 4 and 6 o'clock in the afternoon. Some type of food has already been prepared, awaiting their arrival, and while the men are eating, the women occupy themselves in dressing the day's kill for the evening meal, which will be eaten as soon as it

can be cooked. If darkness has not descended, a bath and sexual intercourse frequently follow the dinner, after which the Indians retire to their hammocks to smoke, play with the children, and talk until sleep overtakes them. Fatigued by a day of work or of walking in the forest, most members of the camp are asleep by 8 o'clock, unless there is to be a dance or a drinking feast.

WORK AND DIVISION OF LABOR

Labor is not a virtue among the Siriono. They are relatively apathetic to work (*tába tába*), which includes such distasteful tasks as house building, gathering firewood, clearing, planting, and tilling of fields. In quite a different class, however, are such pleasant occupations as hunting (*gwáta gwáta*) and collecting (*déka déka*, "to look for"), which are regarded more as diversions than as work. This is not to be wondered at, since these latter pursuits are more directly and immediately connected with the urge for food than are the more distantly rewarding labors of agriculture. What seems to be true, to put it psychologically, is that the responses of hunting, fishing, and collecting have been and are more immediately reinforced than those of agriculture.

When food, especially meat, is plentiful, little work is performed. What people like best to do at this time is to lie in their hammocks, rest, eat, indulge in sexual intercourse, sleep, play with their children, be groomed, sing, dance, or drink. Free time is rarely employed in improving the house, although rain is expected, or in enlarging a garden plot, although the supply of food is insecure. When the immediate needs for food have been supplied, a person is neither much criticized for doing nothing, nor much praised for occupying his time in constructive labor.

Besides the immediate desire and necessity for food, the incentives to labor are few. No prestige is gained by building a better house or a larger garden, both of which may have to be abandoned on the next move. It would seem, in fact, that the nomadic character of the band is the principal reason for not working, because the results of one's labor can rarely be carried with one.

The nuclear family is the basic work group. Although considerable cooperation in the performance of duties takes place between members of an extended family, there are few tasks whose

performance necessitates the cooperation of all members of the band. The nearest approach to such cooperation occurs when the band is on the march—when a new camp site has to be cleared or when a new house has to be built. But even in carrying out these tasks, members of an extended family join together to clear the part of the site which they will occupy or to build that section of the house where they will live. In this simple society the ties of kinship are strong.

Within the family, the division of labor follows normal lines of age and sex, except that the duties performed are neither as highly differentiated nor as sharply defined as in many preliterate societies. The peculiar circumstances prevailing in this environment and culture sometimes demand that a person perform temporarily, at least, tasks that might otherwise be delegated to the opposite sex. Thus, although cooking is normally the role of a

TABLE 2.—Distribution of labor according to sex

Activities	Men and women	Women	Men
Collecting	×		
Clearing.....	×		
Planting.....	×		
Tilling	×		
Harvesting.....	×		
Dressing game.....	×		
Burden carrying	×		
Cooking.....		×	
Caring for children.....		×	
Spinning thread.....		×	
Twining string.....		×	
Twining bowstring		×	
Twining hammocks.....		×	
Twining baby slings.....		×	
Carrying water.....		×	
Collecting firewood.....		×	
Extracting clay.....		×	
Pot making.....		×	
Pipe making.....		×	
Weaving mats.....		×	
Weaving fire fans		×	
Weaving baskets.....		×	
Making mead.....		×	
Preparing leather ornaments.....		×	
Stringing necklaces.....		×	
Cutting and depilating hair.....		×	
Hunting.....			×
Fishing.....			×
Felling trees.....			×
Extracting honey.....			×
Weapon making.....			×
Tool making (spindle, digging stick, etc.).....			×
House building.....			×
Bridge making.....			×
Refining beeswax.....			×
Preparing utensils (calabashes, mortar and pestle, etc.).....			×

woman, when the men are off on the hunt it is they who must barbecue the meat. Similarly, although basketry is the art of women, men must sometimes make baskets in which to carry home game.

On the whole, however, the sex division of labor follows the pattern presented in table 2.

TRAVEL AND TRANSPORTATION

Although rivers and lakes abound in the territory traversed by the Siriono, all movement and transportation take place on foot, overland. Considering that the water courses are extremely abundant, that the Siriono are constantly crossing rivers and streams in their wanderings, and that there is no lack of excellent materials in the environment from which to build canoes, it is surprising that they have remained unique, as compared with their immediate neighbors, in not constructing watercraft of some kind. Even though they are not a river people—their camps are usually located inland—the number of lakes and streams in their territory would seem to justify the use of watercraft, not only as an adjunct to foot travel, but as a means of augmenting the food supply as well. Since much of the activity related to the food quest, during the dry season particularly, centers around the lagoons and streams, canoes would be of great advantage in fishing and in stalking waterfowl. It would seem, in fact, that the lack of canoes can only be explained by such hypotheses as that they have never tried to build them or that attempts to build them have proved unrewarding.

The trails (*ñénda*) over which transportation and hunting take place are not built; they simply grow up from use. A hunter may strike out in a general direction through the forest in quest of game, and as he follows his meandering course, avoiding dense growths of underbrush where travel is difficult and going around fallen trees that may impede his progress, he bends over a few leaves and twigs. In his travels he may encounter a water hole, a stream, or a lake where hunting is good, and if this be the case, he may return again and again to the same spot, sometimes with his tribesmen, until by frequent use a new trail is formed. When a new camp site has been settled, trails grow up rapidly as a result of hunters and collectors making food recon-

naissances in all directions from the house. Those routes yielding game are traversed again and again, while those proving sterile are immediately abandoned.

Trails are never cleared and are very poorly marked. About every 15 feet or so a small plant or a piece of brush is bent over to the right of the direction in which one is proceeding. Thus one can always tell in which direction the trail runs or was made. Except in the cases of trails which connect one camp site with another, the network of trails roughly follows the pattern of a wheel. With the camp site as the hub, a trail goes out along one spoke and returns by another. A great deal of crisscrossing and overlapping, of course, do occur.

It is impossible for the uninitiated to follow these rude paths. Since most Indian hunting trails lead out from a hut and back to it, one must make many sterile attempts in trying to trace the course of a band from one abandoned hut to another, before striking the path that connects two houses. Even when I was traveling with Indians of the same tribal group, I found that they, too, were never sure whether a newly discovered trail was an abandoned hunting trail of another band or whether it might actually lead us on to the spot where the band was settled.

When on the march the Indians do not move great distances in a single day. The lack of good roads, the necessity of crossing swamps and streams, the impediment of young children who must be carried or who cannot walk rapidly, the burden of the gear—the hammocks, the pots, the baskets, the calabashes, the food, etc.—all hinder progress considerably. When lack of food or water forces a band to move, the members usually average not more than 8 or 10 miles a day, and since they stop to rest, hunt, and gather at each camping place, movement of the entire band does not usually take place more often than every 4 or 5 days. Unless there is some definite objective toward which they are traveling, they exhaust the wild life of an area as they travel.

While I was living with a band on the march for about 6 weeks during September and October 1941, while they were traveling from a camp site northeast of Yaguarú, Guarayos, to Tibaera on the Rio Blanco, it took them about a month to travel about a hundred miles. Movement of the entire band took place on the average of every 3

days. There were nine camps between the starting point and the objective, which means that on days when movement took place approximately 10 miles were covered. It is difficult, however, to make any generalizations as to the amount of travel done by a band, since so much depends on the food supply in the area. Some camps may be abandoned within a few days' time, while others may be occupied for more than 6 months. I visited some 50 sites that had been variously occupied and abandoned during the past 20 years.

The amount of band travel, however, cannot be taken as a measure of the amount of travel done by individual hunters or by family groups. Hunters may cover as many as 40 miles a day in their quest for game, and when nuclear families are away from the band on hunting and gathering expeditions, they, too, may travel great distances in a single day. I have made trips with a man, his wife, and young child when we walked as many as 25 miles in a single day.

When on the move, men cooperate with the women in carrying the family burdens, which are packed in carrying baskets woven from the green leaves of the motacú palm. These baskets are carried on the back, being suspended from the head (women) or shoulders (men) by a tumpline of liana.

Considerable weight may be transported by these methods. The average pack for a man or woman runs around 60 or 70 pounds. When meat is being transported in from the forest, I have seen a man carry up to 200 pounds on his back for a distance of 10 miles without exhibiting a great deal of fatigue. When the Siriono are traveling or carrying burdens, however, brief halts are usually made about every 2 hours for purposes of resting.

Young children are carried by the mother in a sling which is slung around her shoulder. The baby sits in the sling with its legs astride her hip. When marching in the forest a man may sometimes relieve a woman in carrying the children, but he will never enter camp carrying "female possessions."

On the march the men, with their bows and arrows over their shoulders, go ahead of the women. If game is sighted they temporarily drop their loads and give chase. By the time the next camping place is reached, they have generally killed some animals for the evening meal.

In walking over the narrow paths, the Indians march in single file and walk with the toes pointed inward at an angle of about 45° to prevent sticks and thorns from bruising the tender skin between their toes. Because of this habit, the Siriono have become a really pigeon-toed people.

Although no type of watercraft is manufactured or used, rivers, swamps, and streams offer little hindrance to travel except during the rainy season, when most of the country becomes one continuous body of water. But as already noted, little movement takes place at this time. Even in the dry season, however, there are brooks, streams, and swamps to cross in every day's travel. Since the bodies of waters are low at this season most of them can just be walked through, but if the water is found deeper than the height of one's head other means of crossing must be resorted to.

The most common method of crossing a deep stream is to fell a tree from one bank to the other. If the stream is fairly wide, a tree may be felled from either bank. If this does not prove feasible, a heavy liana may be tied to trees on both banks—one individual swims across with the liana—and the people pass from one side to the other by going hand over hand along the liana, the body being buoyed up by the water. It is interesting to note that D'Orbigny (1835-47, vol. 4, pp. 343-344) first called our attention to this method of crossing the rivers more than a hundred years ago. When crossing streams or rivers, burdens are generally placed on the head to keep them dry, and the children are carried astraddle on the shoulders.

A great many streams become stagnant during the dry season, and are covered with a dense blanket of water grass. These growths are usually so thick that one can walk quickly over their tops without sinking into the water below. But for aid in crossing such streams saplings or bamboos are sometimes laid on top of the grass so as to make a temporary bridge.

When all other methods prove to be of no avail in crossing a river or a stream, swimming is resorted to. The Siriono are excellent swimmers. They swim with a crawl stroke, as well as "dog fashion." In spite of the abundance of palometas and alligators, every child of 8 knows how to swim.

Finally, it should be mentioned that in crossing deep rivers or streams, people usually cover their genitals with one hand so as to protect them from the palometas which infest all of these waters.

They also step with care so as to avoid sting rays, whose stabs leave nasty wounds.

ART, MUSIC, AND DANCING

Art, apart from the song and dance, has remained at a very backward level among the Siriono. Beyond the stringing of necklaces, the painting of the body (without design), and the decoration of hair with feathers, no attempt is made to embellish anything. Most objects of the culture, in fact, seem to have a purely utilitarian reason for existence. Pottery is not only rude but plain. Such things as bows and arrows and calabashes are never decorated. Moreover, the idea of portraying some aspect of the culture, realistically or symbolically, by drawing, painting, or sculpture is completely foreign to these Indians.

What has been said of art can also be said of the instrumental aspect of music. Not a single type of musical instrument is known. Not even such rhythm-beating instruments as rattles or clappers are employed, nor is anything ever hung on the body to make noise to accompany singing or dancing. All music, in fact, is vocal. Singing does, however, play an important role in the culture.

Early morning singing, which makes it impossible for anyone to sleep after it starts, is a definite part of each day's routine, especially when the group is settled for any length of time as they were at Tibaera. Even on the march, or when a man is out alone with his family, this practice is followed. Everyone sings. The songs are monotonous, impromptu chants, which sometimes have reference to some aspect of the food quest. From some distance away, the early morning chorus sounds not unlike a group of howler monkeys heralding the day from the top of some distant tree.

When I was first with the Indians I forced myself to leave a comfortable hammock and mosquito net many times at about 3 a. m., and, with flashlight, pencil, and notebook in hand, I made a sincere effort to record some of this early morning music. After a series of unrewarding attempts, however, and under extremely unpleasant conditions, I allowed the Indians to greet the day without the nuisance of my presence. My informants all told me, however, that the songs had no meaning, and, as far as the words were concerned, I

am inclined to believe that this is true. In discussing the question with Abraham Richards, the son of an American cattle rancher who was born and raised with a group of Siriono on his father's cattle ranch near El Carmen, he told me that he, also, was never able to make any sense out of these early morning songs. However that may be, on inquiring of informants as to why they always greeted the day with songs, one of two reasons was always given: either they were happy or they were like the birds ("Hadn't I noticed that most of the birds and some of the animals greeted the day with song?"). Singing in the morning thus may perform the function not only of pleasantly filling in the period between darkness and dawn, after sufficient sleep has been obtained and before the activities of the day begin, but also of reinforcing the bonds maintained with the animal world.

The importance of singing at drinking feasts has already been stressed. The songs sung at this time, like those sung in the early morning, are largely impromptu. To record them without instruments is next to an impossibility, because the singers are drunk and mumble their words more than usual. Insofar as I was able to determine, however, they are stylized only as to form and rhythm and never as to content. Informants said that when drunk they sang whatever rhythmic combinations came into their heads.

The most meaningful songs seem to be those that are sung in connection with the dance. Dancing (*yuriki*) is always accompanied by singing (*hidási dási*) and is a very common way of passing parts of the long tropical nights especially when the moon is shining. Group dancing is rarely indulged in during the day or on nights when the moon is dark. On such nights a fear of evil spirits keeps the Indian close to his hammock.

Both men and women dance to the accompaniment of songs, but they never dance together. Nor do people dance alone. A man (or woman) wishing to dance may get up and do a solo number by way of animating his tribesmen to join him, but the expression of the dance comes through participation of several people in the circle.

In forming the dance circle, men link their arms in the following manner. With his right hand one grasps the left wrist of the second person on one's right. One's left wrist is then grasped by the right

hand of the second person on one's left. When the circle is completed one's back is thus encircled by the left arm of the person on one's right and by the right arm of the person on one's left.

Following the formation of the circle the dancing and singing begin. The participants throw back their heads and stamp their feet alternately up and down firmly to the rhythm of the music. The circle itself remains stationary during the first phase of the dance. When the dance begins, the beats of the feet are coordinated with the accented syllables of the following song, which is sung in unison:

hito hito hito hito
ti su á ča
yí sa dí mosé
á tí ba tí i čá
ai i ča
mimbá mimbá

This song is always sung at the opening of a dance, whether it be men or women that are dancing, but I was unable to get a translation of it. All of my informants told me that the song was meaningless, but it does contain some meaningful words, such as *yisádi mosé* ("when dancing") and the expression *hito* which probably here means "happy." This suggests that part of the song, at least, means something like "I am happy when I dance."

During the first phase of the dance, the song quoted above is sung over and over again in unison about 25 times, by which time a considerable emotional enthusiasm has taken hold of the group. After a brief rest, the second phase of the dance begins, also by everyone singing a song in unison. Some verses of this song are quoted below:

áh áh áh áh áh
sán de ra čá
tá du bá
múndu
čú du já há

nđe ra já nendá
ta míNge
múndu
čú du já há

ai sai ibi ató
ai sai ibi ató
ibi kwa
kú ru kwá ta
ki a tá
ai sai ibi a jú du
mún du bá
a túru bá

múndu
čú du já há

Although the above song contains certain meaningful words, a translation is impossible because it seems to follow no grammatical pattern. After a number of verses have been sung over and over again to the accompaniment of stamping feet, a leader takes charge of a circle and the singing becomes impromptu. During this phase of the dance, in addition to the stamping of feet, the entire circle of dancers moves round and round counterclockwise, the participants bending their heads downward so as to hear the words of the leader. As he chants a phrase the participants repeat it after him. His phrases often bear on some exploit in hunting or on some event in his life of which he is particularly proud. One moonlight night, for example, Yikináundu (Father of Owl-monkey) chanted for 2 hours about how he had killed tapirs and jaguars; on another, Erésacánta (Strong-eyes) sang for as long a time about how he and his brother killed a white man years ago during the last rubber boom. Since these songs are impromptu and are sung only during a dance, it is impossible to record more than snatches of them without technical equipment, which I did not possess. Nor did my knowledge of the language ever reach a point where I could understand them fully.

The women perform a ring dance similar to that of the men, except that they do not link their arms in the same fashion and do not stamp the ground with such force with their feet. In forming the dance circle women place their arms around the necks of the participants next to them, and their body movements consist of waddling around in a circle counterclockwise, with hips swaying, to the accompaniment of the songs. The women's dance begins with the same song as that of the men. It is sung over and over in unison, after which a leader breaks in with an impromptu chant, the phrases of which are repeated after her by the other dancers. On the whole, the women dance less often than the men.

Everyone knows how to dance and to sing some songs. Since the rhythm of the dance consists merely in the stamping of feet, there is no problem in learning to dance. Young people are often observed forming a dance circle in imitation of their parents. Although all adults know how to sing some songs, certain individuals are known

to be more skillful in composing songs than others. Such people usually take the lead in the dances and play the most prominent role in the singing that accompanies drinking feasts. It may be significant that in the two extended families which I knew well, both of the chiefs were prominent

singers. But although they often took the role as leaders, other individuals equally gifted also frequently assumed the same role. There are no professionals—no persons who are always called upon to sing at a drinking feast or to chant at a curing rite.

FOLK BELIEFS AND SCIENCE

The Siriono conception of the universe is an almost completely uncrystallized one. My Indian friends never voluntarily talked about cosmological matters, and when I attempted by questions to gain some insight into their ideas about the nature of the universe I almost always met with failure. Young men would say, "Ask the old men," and the old men would answer, "I do not know." Even the sage of one of the extended families, Embúta (Beard), although he showed considerable interest in my inquiries and gave me unhesitatingly what information he possessed, was simply unable, for lack of ideas, to enlighten me on most points. On several occasions I even held consultations with those whom I regarded as the sages of the band, but got only general agreement that nothing was known about this question or that. It would seem that their concern with the immediate world has left the Siriono little time to speculate on cosmological matters.

The more or less indifferent attitude taken toward the universe is clearly reflected in the virtual lack of folklore and mythology. The Siriono are one of the few primitive peoples I know of who do not devote a considerable part of their free time to the telling of folk tales and myths. In about 8 months of more or less permanent (i. e., day and night) residence with them, only twice was anyone animated to tell a folk tale or story of his own accord. After making one unsuccessful attempt after another to get informants to relate myths and tales, I was forced finally to conclude that this phase of culture was simply not developed, that there was no fund of folklore and mythology upon which to draw. If people did any talking at night it usually had reference to some happening in the immediate world, such as a tapir hunt or a quest for wild fruits.

Moon (Yási) is the culture hero of the Siriono. Formerly he was a great chief who lived on the earth. At that time there was nothing but water

and a race of harmful people. Moon destroyed these evil beings, and at the places where they were killed, the reeds from which the Siriono make their arrows sprang up. Moon then created man and the animals. At first both were in a kind of amorphous state. The animals were too hot to touch and burned the arms of the men who came in contact with them. Jaguars, especially, killed many men before the latter learned how to hunt them. Moon taught men how to hunt and fish, to make bows and arrows, to plant crops. He gave them maize, papaya, manioc, chonta, and wild fruits and plants. In fact, he is responsible for the world and everything in it.

Moon is now believed to live in the sky. The reason for his ascending to the heavens is revealed in the following folk tale, which also explains why the animals have the shapes and colors they now possess.

Yási (Moon) had a child. Yákwa (Jaguar) was de-lousing the child and killed him by biting him in the head. Then Yási came along and said, "Who killed my child?" Yoíta (Fox) was standing by and said, "I do not know." Yákwa was hidden between two mats of motacú at this time. Then Yási went along and began to ask all of the other animals, "Who killed my child?" All of them answered, "We do not know." Then he came to where Erúbat (Spider Monkey) and Téndi (Howler Monkey), and Seáci (Coati) were having *héri héri* (a drinking feast). Yási was very angry. Erúbat wanted to be red in color like Téndi, but Yási said, "You will be black." Yási was angry because all of the animals were drunk. Then he grabbed Téndi by the neck and pulled it into the shape it now has. Kwáundu (Porcupine) was standing by, got angry with Yási and began to scratch him. Yási put spines in his back and fixed his feet so that he could not scratch. He also twisted the feet of Antanbúja and Antandíša (Anteaters) and picked up Konómbi (Tortoise) and threw him down again, saying, "You will not walk fast." All of the animals were very angry. That is why Erúbat and Téndi howl so loudly today and that is why Erúbat throws chonta fruits at one when one passes by. Yási was still very angry and decided to go up into the sky. He began to climb a huge tree up into the sky. Before going up he told Yákwa to follow him, but Yákwa did not know how to climb very well and when he got

part way up he fell down into the water below and was eaten up by Sénye (Palometas), who were enormous in those days.

The folk tale quoted above, of which there are a number of variants, was about the only one I ever heard the Siriono tell. Although Moon is credited with having started everything in their culture, stories to account for these things were never told. I could get no supporting myths, for instance, for the origin of the world, the origin of men, or the origin of fire, even though informants were agreed that Moon was responsible for them.

Moon now lives in the sky. He is a great chief. He spends about half of his time hunting. During the dark of the moon the Siriono say that he is far away, hunting peccary. To explain the waxing moon, Embúta told me that when Yási comes back from these hunts his face is very dirty; he washes a little of it each day until, when the moon is full, his face is clean. To explain the waning moon, he said that when Yási goes on a hunt he gets his face a little dirtier each day, until before long it is so dirty that it cannot be seen at all.

In the explanation of natural phenomena, Moon also plays an important causal role. One explanation of thunder (*ingičínámo*) and lightning (*iNgúí*) is that they are caused by Moon throwing peccaries and jaguars down from the sky. An alternative explanation of thunder was offered by Aéíba-eóko (Long-arm), who stated that it was caused by Moon pulling up bamboo in the sky. Still a third interpretation of thunder and lightning, one that has no relation to Moon, is that they are caused by a huge jaguar (*yakwadúsu*) who lives in the sky. When this jaguar winks his eyes there is lightning, and when he shakes himself there is thunder. There was no general agreement among informants as to which of these interpretations is correct.

Thunder and lightning, however, are always greeted with howls by the men, who step outside of the house and roar at the sky. This is believed to drive the thunder and lightning away. Informants also told me that it was good to dance and sing during a thunder storm, as it would then disappear more quickly, but I never saw them practice what they preached in this respect.

As to other celestial phenomena, no distinction is made between the planets and the stars, and there is no grouping of stars into constellations.

Both planets and stars are called *yási táta* (moon fire). Insofar as I could tell, these "moon fires" are believed to be caused by the moon, although in places where Christian influence has penetrated they are thought to be fires of people who live in the heavens. I was unable to get any causal explanation for the rainbow (*ibe íri*), although its appearance presages an epidemic of colds. One of my Casarabe informants, Kénda, told me that the rainbow contained an *abačikwaia* ("evil spirit") which causes sickness of the nose and throat. Eclipses, it seems, are unknown; at least I was unable to get any interpretation of them. Beyond the statement that the sun is "fire" and is responsible for the light of day, I could get no native explanation of it.

Mist (or fog) is called *tatási* (smoke), and is equated with smoke from fires or pipes. Rain is caused by the overflowing of a large lake which is believed to exist in the heavens. Winds (*kíridía*), especially the cold south winds that come from Tierra del Fuego during the dry season, are believed to be caused by *abačikwaia*. No special significance seems to attach to whirlwinds, of which I was unable to get an explanation, although storms generally are also thought to be caused by *abačikwaia*.

Most adults have an excellent knowledge of the geography of the area in which they wander. No matter how meandering his course, the Indian never gets lost in the jungle and is able to return directly to the spot from which he started. While no more than two cardinal points—east, where the sun rises, and west, where the sun sets—are recognized, the course of the sun in the sky, together with such marks as topographical phenomena and water courses, accurately guide the Indian on his way.

Knowledge of plants and animals is most extensive. When the plants flower, when they bear their fruit, which ones are good to eat, etc. are known by every child of 10. The habits of animals—what they eat, where they sleep, when they have their young, etc.—are common knowledge to every boy of 12.

NUMERATION, MENSURATION, AND TIME RECKONING

The Siriono are unable to count beyond 3. In counting to 3, however, the following words are employed: *komí* (1), *yerémo* (2), *yeremóño* (3).

Everything above 3 becomes either *etubenta* (much) or *eáta* (many).

In counting, the fingers are sometimes employed to illustrate the desired number by placing one, two, or three of them on the nose. In indicating any number above 3, in addition to saying "many," the fingers on one or both hands may be held up, or, if the number is very great, the toes may be thrown in to boot. For instance, when a returning hunter is asked some such question as "How many turtles did you find?", if the answer is below four he will hold up the appropriate number of fingers to his nose and say the number; if it is above three he may hold up a confused number of fingers and just say "many"; if it is very great he may demonstrate his toes as well.

The inability to count beyond 3, however, does not mean that an absence of one object from among a large number will not be noted. A man who has a hundred ears of corn hanging on a pole, for instance, will note the lack of one ear immediately. Thus the mathematics of the group, when it comes to counting above 3, at least, seems to be based on some kind of Gestalt; whether something has been added to or subtracted from the visible total will be known because of a change in configuration.

Since trade and commerce are completely foreign to the Siriono, they employ no weights or measures. The size of pots, the length of bows and arrows, etc., are determined entirely by guess. The length of a hammock, of course, is roughly determined by the height of the person who will use it, but no tools of any kind are employed in measurement. The same may be said for measurements of distance, which is merely expressed in terms of far (*íšo*) and near (*aiíti*) with the addition of gestures. With respect to distance, the Indians sometimes employ such vague references as one, two, three, or many "sleeps," i. e., days away on foot.

No records of time are kept, and no type of calendar exists. The year, with its division into

months or "moons," is quite unknown. Events are sometimes referred to phases of the moon, but such references are extremely vague. The seasons, of course, are clearly recognized from such phenomena as the receding of waters, the flowering of plants, the ripening of wild fruits, and the harvest of reeds, but seasons are not named and are not coordinated by the Siriono into any kind of calendar year, although such a calendar might easily be compiled. In referring to past events, the Siriono most frequently say that they happened *kóse mosé*, which may mean any time before the day before yesterday. Events are also sometimes referred to as having taken place "when I was a little girl" (*yukwáki mosé*), "when I was sick" (*šerási mosé*), "when I killed a tapir" (*šedkwantu máno mosé*), "when I was living at the old house" (*še čučúa tma mosé*), etc.

Day is referred to as *ñási* and night as *itonđáru*. Tomorrow is known as *isamámi* and yesterday as *kúdi*. To express the day after tomorrow or any day in the future the Siriono say *isamámi anóNge* ("brother of tomorrow"), and they similarly call the day before yesterday *kúdi anóNge* ("brother of yesterday"). Today is always expressed by *námo* ("now"). The time of day is indicated by the position of the sun in the sky. When one asks a Siriono "Where is the sun?" ("*ma tendá ši mánde?*"), one may get any of the following answers, depending on the time of day or night:

erésai i tendá bi ("the sun can be seen")—about 6 a. m.

ténda čui ("the sun is out")—about 8 a. m.

ténda čui teñu kóti ("the sun is well up")—about 10 a. m.

ténda nánde ileré ("the sun is overhead")—noon.

ténda óso ("the sun is leaving")—about 4 p. m.

ténda osóti ("the sun is low")—about 5 p. m.

ténda óso teñu kóti ("the sun is well down")—about 6 p. m.

ibi ta ténda kóti ("the sun is under the earth")—about 7 p. m.

edesai ito ("hard to see")—twilight.

ito námo ("soon dark")—about 7 p. m.

itonđáru ("darkness")—about 8 p. m.

itonđáru túti ("very dark")—about 10 p. m.

itonđi ("pitch dark")—about midnight.

SOCIAL AND POLITICAL ORGANIZATION

THE FAMILY

The nuclear family, consisting of a married man, his spouse or spouses, and their children, is the fundamental social and economic unit among the Siriono. Most of the activities of the culture, in fact, revolve around the nuclear family. Hunting is largely a family affair, as are fishing, collecting, and agriculture. Siriono society, moreover, contains no specialists; the only occupational differences are those based on sex and age. Hence all work such as basket making, tool making, weapon making, and pot making must be done within the family. So important is the nuclear family that the culture contains few activities and the society performs few functions that are not embodied in or performed by individual family groups.

Family life centers not in a separate dwelling but around the hammocks of the husband and wife, which are hung in the communal dwelling of the band. Each monogamous family generally occupies two hammocks; one is for the man and the other for his wife and children. In polygynous families the wives occupy separate hammocks, which are placed with reference to the hammock of the husband according to their status in the family hierarchy. The first wife usually occupies the position to the right of the husband; the second, to the left; the third, at his head; the fourth, at his feet. Between these hammocks lie the family hearths or fires upon which the cooking is done. Since the distance between the hammocks is seldom greater than 3 feet, a nuclear family, if monogamous, rarely occupies a space greater than 8 feet square. Within this hang the calabashes of water, the baskets of food, and all other family possessions.

While one usually enters a family group by birth or by marriage, it is also possible to enter by adoption. Among the Siriono, however, there are no formal ceremonies of adoption, nor are any specific relatives designated to take care of orphan children. One orphan whom I knew was being raised by his maternal grandmother; a second, by her mother's sister; still a third, by his mother's parallel cousin (a classificatory sister), who also happened to be his father's second wife. Informants told me, however, that a mother's sister of an orphan child was most frequently designated

to assume the mother's role. Insofar as I was able to determine, adopted children are treated in about the same way and are considered as much a part of the family as natural children.

Adults are never adopted. After living about 8 months with the Siriono, during which time I was on *šenóNge* (my brother) terms with the chief and often hung my hammock next to his, I was never regarded as a member of the family except in a joking way. While I was respected and generally liked, I was always looked upon as an outsider.

Within the nuclear family authority is patriarchal. A woman is subservient to her husband, while children are subservient to both parents. In polygynous families the first wife—generally the one to whom the man has been married the longest—is dominant over all other wives. While considerable economic cooperation takes place between cowives in a polygynous family, more work is done by the secondary wives than by the first wife. The former, for instance, are always required to do the menial tasks, such as bringing in firewood and water. The first wife, moreover, is privileged to distribute her husband's game, she usually gets the first choice (after the husband) of food, and it is usually her son who succeeds his deceased father if the latter was a chief. Furthermore, it is at the hearth of the first wife that the husband generally eats. The secondary wives maintain hearths of their own where they cook for themselves and their children.

A man enjoys sex rights with all of his wives, but they are not necessarily exercised in any prescribed manner such as by rotating from one wife to another or by concentrating principally on the first wife. In sororal unions the kinship tie between cowives doubtless does much to mitigate friction that might otherwise arise between them, but in nonsororal plural marriages sexual jealousy between cowives is sometimes intense. Since food and sex go hand in hand in Siriono society—and there is a scarcity of the former—the wives with whom the husband most frequently has sex relations are also the ones who generally get the most to eat. Consequently, cowives frequently vie with one another for the sexual favors of their husband. This sometimes leads to bitter fights and quarrels. If, for instance, a first wife is

growing old and is receiving less and less attention from her husband as regards both food and sex, she frequently displaces the aggression she feels for him, but cannot express directly, to a younger wife who is enjoying his favors at the moment. Such outbursts of emotion sometimes culminate in bitter fights, the women tearing up each other's hammocks and striking each other with digging sticks and spindles. An aging first wife generally maintains her dominance in the family for a while, but as her husband pays less and less attention to her, she gradually resigns herself to a secondary role in the household. She continues to cling to her economic rights, however, as long as she possibly can, and these are usually maintained longer than her sexual dominance.

A man generally takes no part in the fights that break out between his wives; indeed he is usually away on the hunt when they occur. Only if they occur too frequently or become too violent does the husband interfere. Under these conditions he may threaten with divorce the wife standing lower in his favor, in order to keep peace in the family.

While relations between husband and wife are generally amicable, quarrels are of frequent occurrence. They usually arise over questions of food and sex. When a man has been out hunting all day without eating and arrives home to find that his wife has not prepared something for him to eat, or if he has had ill luck in hunting and is chided for this by his wife, a quarrel is apt to arise. In situations of this kind it is the husband who expresses the stronger aggression, and as a rule other members of a family take no part in a marital dispute.

If a man is only mildly angry with his wife, his feelings usually go no further than harsh words. He may accuse her of being *etómi* (lazy) or *ečim-bási* (promiscuous), or threaten her with divorce. If his anger rises to a higher pitch, he may rip a string or two from her hammock or smash one of her pots. If his anger becomes intense, he may tear her hammock to shreds, chase her out of the house with a firebrand, or even turn his anger against himself and break his bow and arrows. He never beats her, however. Following an intense outburst of aggression, to which a woman responds by crying and running into the bush, a man usually leaves the portion of the dwelling which he occupies with his wife and goes back to

his relatives until amicable relations have again been established. A man signifies his desire for reconciliation by returning to the hearth of his wife.

THE EXTENDED FAMILY

Besides being a member of a nuclear family, every Siriono also belongs to a larger kin group, the matrilineal extended family. Such unilineal kin groupings as moieties, clans, and sibs are not found among the Siriono. Because of matrilineal residence, groups of matrilineal relatives tend to cluster together in the house and to form extended families. An extended family is made up of all females in a direct line of descent, plus their spouses and their unmarried children.

The primary function of the extended family is economic. While the nuclear family is the basic economic unit, considerable cooperation in the performance of duties also takes place within the extended family. Such cooperation is often heightened by the fact that brothers frequently marry sisters and thus continue the cooperative role they played in their family of orientation.

The distribution of food rarely extends beyond the extended family. Members of an extended family cooperate to build that portion of the dwelling which they occupy. They sometimes plant gardens in common. A woman often gathers food with her sisters or her mother, and when brothers are members of the same extended family they frequently hunt together. Sometimes the entire extended family leaves the band for a while as a unit and goes on a hunting and gathering expedition.

The extended family is generally dominated by the oldest active male. Although his power is not supreme like that of the father in a nuclear family, younger members of the extended family usually pay heed to his words. The head of an extended family, however, does not possess any title, such as that of chief.

THE BAND

The local group or band is the largest social group to which a Siriono belongs. In a certain sense the band is also a kin group. Since bands rarely have contact with one another and are thus largely endogamous, it is possible for most band members to trace their descent through one line or another to every other band member.

One feature of Siriono society makes it most difficult for the ethnologist to determine the actual constitution of the band. A very active system of teknonymy operates to make the collection of genealogies an almost impossible task. Every time a Siriono is the father or the mother of a child, his name is changed to that of the child with an additional suffix indicating father or mother. This, coupled with the fact that nicknames are also frequently changed, makes it possible for an Indian to have as many as 15 or 20 names during the course of a lifetime. One's father, for instance, will not have the same name after one's own birth that he had after the birth of one's elder brother. Consequently, if the ethnographer asks two people, whom he knows to be brothers, the name of their father, he may get two entirely different names for the same person.

When I first began to work among the Siriono I remained entirely ignorant of the system of teknonymy until I began to collect genealogies. Analysis of these proved to be useless in establishing relationships between people whom I knew to be related. A dead ancestor was almost always referred to by as many names as I had informants. After 4 months' study at Casarabe—made difficult, of course, by the break-down of the old social organization—I was unable to check my findings by genealogies because of the operation of teknonymy, even though I had acquired a fairly complete knowledge of the kinship system and the rules of marriage through face-to-face relationships.

By the time I got to Tibaera, of course, my knowledge of the language had increased considerably and I was well aware of the system of teknonymy. Thus when I returned from the forest with the band of Ačíba-eóko (Long-arm) in October, 1941, I threw away my old genealogies and began systematically to collect new ones from almost every member of this group. Careful analysis of this material, though much of it proved useless, revealed that, even with the operation of teknonymy, certain nicknames in particular tended to persist, and I was thus able to get a number of reliable instances where two men who said they were brothers actually did have the same father and mother. Once having a tangible basis of this kind to work upon, I was able to trace out rather fully, by checking back on old names, a

number of genealogies and to work out the kinship system and rules of marriage. I was never able, however, to determine the actual kinship of every band member to every other band member, even though I could record the kinship terms by which they designated each other.

In the 5 extended families who made up the entire band of Ačíba-eóko there were 17 nuclear families, all of whom were monogamous except 4. In the 4 extended families who made up the entire band of Eantádu there were 14 nuclear families, all of whom were monogamous except 3. In both bands the chiefs maintained more than one wife: Ačíba-eóko had two, while Eantádu had three. The total population of the band of Ačíba-eóko was 94. Of this number, 25 were adult males, 30 adult females, 18 preadult males, and 21 preadult females. The total population of the band of Eantádu was 58; 17 were adult males, 19 adult females, 10 preadult males, and 12 preadult females. The average number of children per family, considering both bands as a whole, was about 2; in the band of Ačíba-eóko it was 2.3, while in the band of Eantádu it was 1.6. Since the latter band had had considerable contact with the whites, a number of their children had been stolen from them.

Each band occupies a single dwelling, within which cluster the extended families. The chief and his extended family always occupy the center of the house, while the other extended families spread out from his in both directions. During the rainy season, when travel is difficult, the band is a fairly cohesive unit, but during the dry season it is much more loosely organized. At this time nuclear and extended families are often away from the band on hunting and collecting trips that sometimes last 3 weeks or a month.

The chief function of the band seems to be that of supplying sex and marital partners. It performs few economic or ceremonial functions and is held together largely by ties of kinship.

The Siriono have a very weakly developed tribal sense. While bands occasionally come in contact with each other in their wanderings, there are no ceremonial occasions when they all come together. When contacts between bands do occur, however, relations are peaceful.

Bands possess no prescribed territories. If one band runs across hunting trails of another, however, they do not hunt in that area. When I was

traveling with Indians of one band in the neighborhood of a house of another, they were reluctant to do any hunting. Informants told me that where trails of another band existed, the animals of that area belonged to the people who made the trails.

KINSHIP SYSTEM

There are only 11 fundamental kinship terms by which relatives are designated among the Siriono. As can be seen by examining charts 1, 2, 3, and 4 and the list of terms given below, the kinship system is a highly classificatory one; many relationships are signified by a single term.

Kinship term:	<i>Relatives to whom applied</i> ¹
(1) ámi-----	Father's father. Father's father's brother. Father's father's sister's son. Father's mother's brother. Father's mother's brother's son. Mother's father. Mother's father's brother. Mother's father's brother's son. Mother's mother's brother. Mother's mother's brother's son. Mother's mother's sister's son. Mother's brother. Father's sister's husband. Father's sister's son (M. S.). Wife's father (M. S.). Wife's father's father (M. S.). Sister's husband (M. S.). Husband's father (F. S.). Husband's father's father (F. S.). Husband's sister's husband (F. S.). Old man.
(2) ári-----	Father's mother. Father's mother's sister. Father's mother's sister's daughter. Father's father's brother's daughter. Father's father's sister's daughter. Mother's mother. Mother's mother's sister. Mother's mother's brother's daughter. Mother's brother's wife. Father's father's sister. Father's sister. Father's sister's daughter. Wife's mother (M. S.). Wife's mother's mother (M. S.). Husband's mother (F. S.).

Kinship term:	<i>Relatives to whom applied</i> ¹
(2) ári (con.)----	Husband's mother's mother (F. S.). Husband's sister (F. S.). Old woman.
(3) éru-----	Father. Father's brother. Mother's sister's husband. Father's father's brother's son. Father's mother's sister's son. Stepfather.
(4) ézi-----	Mother. Mother's sister. Father's brother's wife. Father's mother's brother's daughter. Father's father's brother's daughter. Mother's mother's sister's daughter. Stepmother.
(5) anóNge-----	Brother. Sister. Mother's sister's son. Mother's sister's daughter. Father's brother's son. Father's brother's daughter. Half brother. Half sister.
(6) yánde-----	Mother's brother's daughter (M. S.). Wife's sister (M. S.). Wife's sister's husband (M. S.). Father's sister's son (F. S.). Husband's brother (F. S.). Husband's brother's wife (F. S.). Potential wife (M. S.). Potential husband (F. S.).
(7) akwaníndu---	Mother's brother's son. Mother's brother's son's son. Father's sister's daughter's son. Son-in-law. Mother's sister's daughter's son (M. S.). Sister's son (M. S.). Father's brother's daughter's son (M. S.). Father's sister's son's son (M. S.). Wife's brother (M. S.). Mother's brother's daughter's son (F. S.). Mother's sister's son's son (F. S.). Brother's son (F. S.). Father's brother's son's son (F. S.).
(8) akwáni-----	Mother's brother's son's daughter. Daughter-in-law. Mother's sister's daughter's daughter (M. S.). Sister's daughter (M. S.).

¹ Male and female speaking unless otherwise designated.

○ = Female
 △ = Male

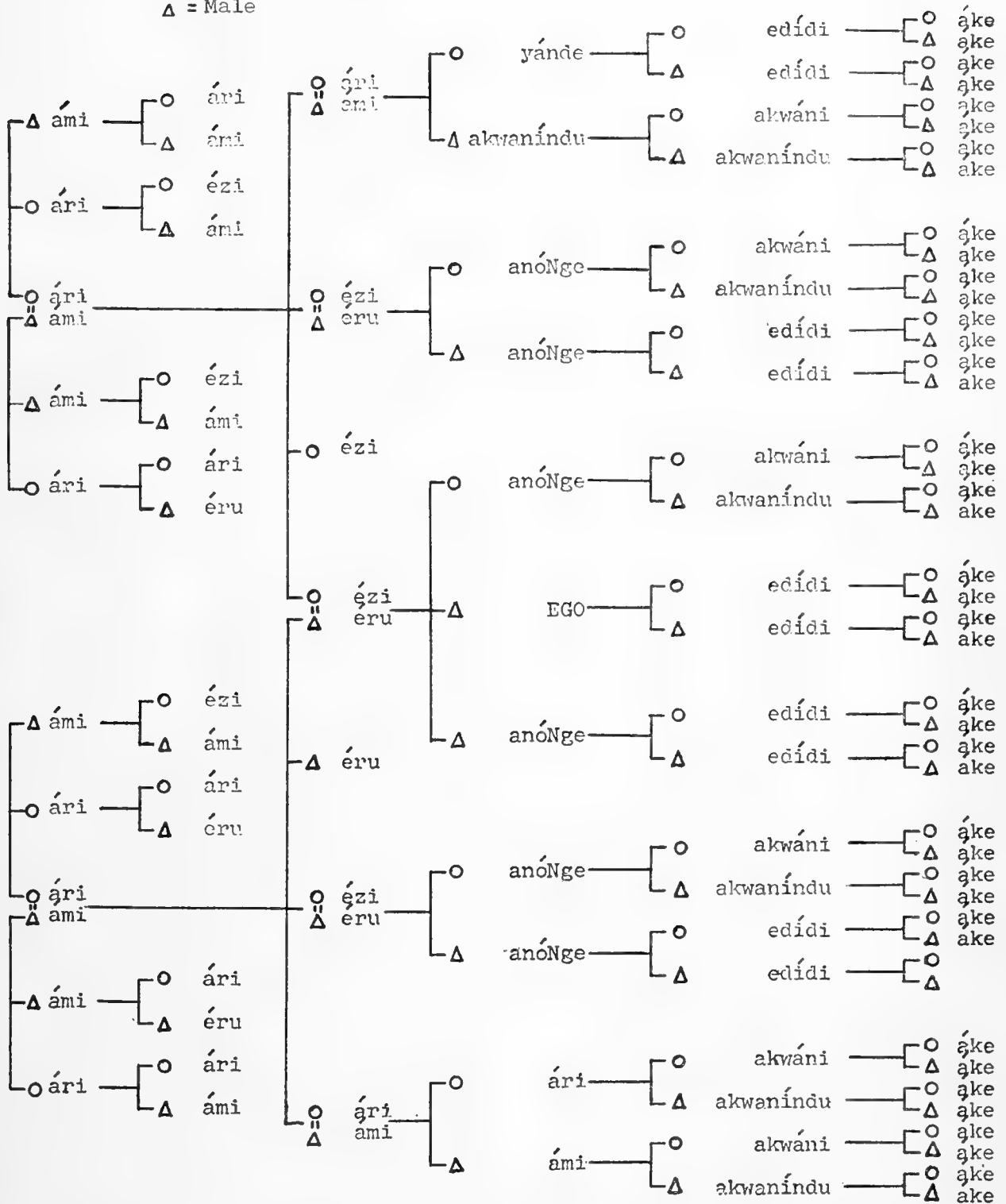

CHART 1.—Lineal kinship chart Siriono (male speaking).

Kinship term:	<i>Relatives to whom applied</i>
(8) akwáni (con- tinued)	Father's brother's daughter's daughter (M. S.). Father's sister's daughter's daughter (M. S.). Father's sister's son's daughter (M. S.). Wife's brother's wife (M. S.). Mother's brother's daughter (F. S.). Mother's brother's daughter's daughter (F. S.). Mother's sister's son's daughter (F. S.). Brother's daughter (F. S.). Father's brother's son's daughter (F. S.). Father's sister's daughter's daughter (F. S.). Brother's wife (F. S.).
(9) edídi-----	Son. Daughter. Stepson. Stepdaughter. Brother's son (M. S.). Brother's daughter (M. S.). Father's brother's son's son (M. S.). Father's brother's son's daughter (M. S.). Mother's sister's son's son (M. S.). Mother's sister's son's daughter (M. S.). Mother's brother's daughter's daughter (M. S.). Mother's brother's daughter's son (M. S.). Sister's son (F. S.). Sister's daughter (F. S.). Father's brother's daughter's daughter (F. S.). Father's brother's daughter's son (F. S.). Father's sister's son's son (F. S.). Father's sister's son's daughter (F. S.). Mother's sister's daughter's daughter (F. S.). Mother's sister's daughter's son (F. S.).
(10) áke-----	Grandson. Granddaughter. Child of nephew or niece. Child of first cousin once re- moved. Child.
(11) ninínfzi ² ----	Wife (M. S.). Husband (F. S.).

Kinship terms are more frequently used in address than personal names or nicknames. The latter, however, are sometimes employed in address and frequently (particularly nicknames) in reference. In husband-wife relationships, moreover, special teknonymic usages prevail. After a child has been born, a man addresses his wife as *akési* (mother-of-child) and he is addressed by her as *akéndu* (father-of-child). These usages, so far as I know, do not extend to other relationships.

The outstanding characteristics of the kinship system are the following:

(1) Kinship is bifurcate-merging. The father's brother is classified with the father, while the mother's brother is designated by another term; similarly, the mother's sister is classified with the mother, while the father's sister is designated by another term.

(2) Grandparents are not distinguished in kinship terminology. Grandfathers and their brothers are designated by the same term as mother's brother, while grandmothers and their sisters are designated by the same term as father's sister.

(3) No sex distinctions are made between siblings and parallel cousins, all of whom are designated by one term.

(4) Cross-cousins are distinguished from parallel cousins, and the cross-cousin terminology reflects the system of marriage. A man marries his mother's brother's daughter, a woman her father's sister's son. Marriage between a man and his father's sister's daughter or between a woman and her mother's brother's son is forbidden. The cross-cousins whom one can marry are referred to by the term "potential spouse." The father's sister's children are terminologically classified with the father's sister and her husband, i. e., they are raised one generation, while the mother's brother's children are classified with nephews and nieces, i. e., they are terminologically depressed one generation. On the basis of cousin terminology the kinship system is thus of the Crow type.

(5) No sex distinctions are made between son and daughter, both of whom are designated by the same term, and this term is extended to include the children of siblings and of parallel cousins of the opposite sex.

(6) Special terms showing sex differences are employed to designate the sons and daughters of

² I am not positive that this term is applied to both husband and wife. Since the kinship system makes no sex distinctions between potential husband and potential wife, I am fairly certain that the same term is applied to actual husband and wife.

○ = Female
 △ = Male

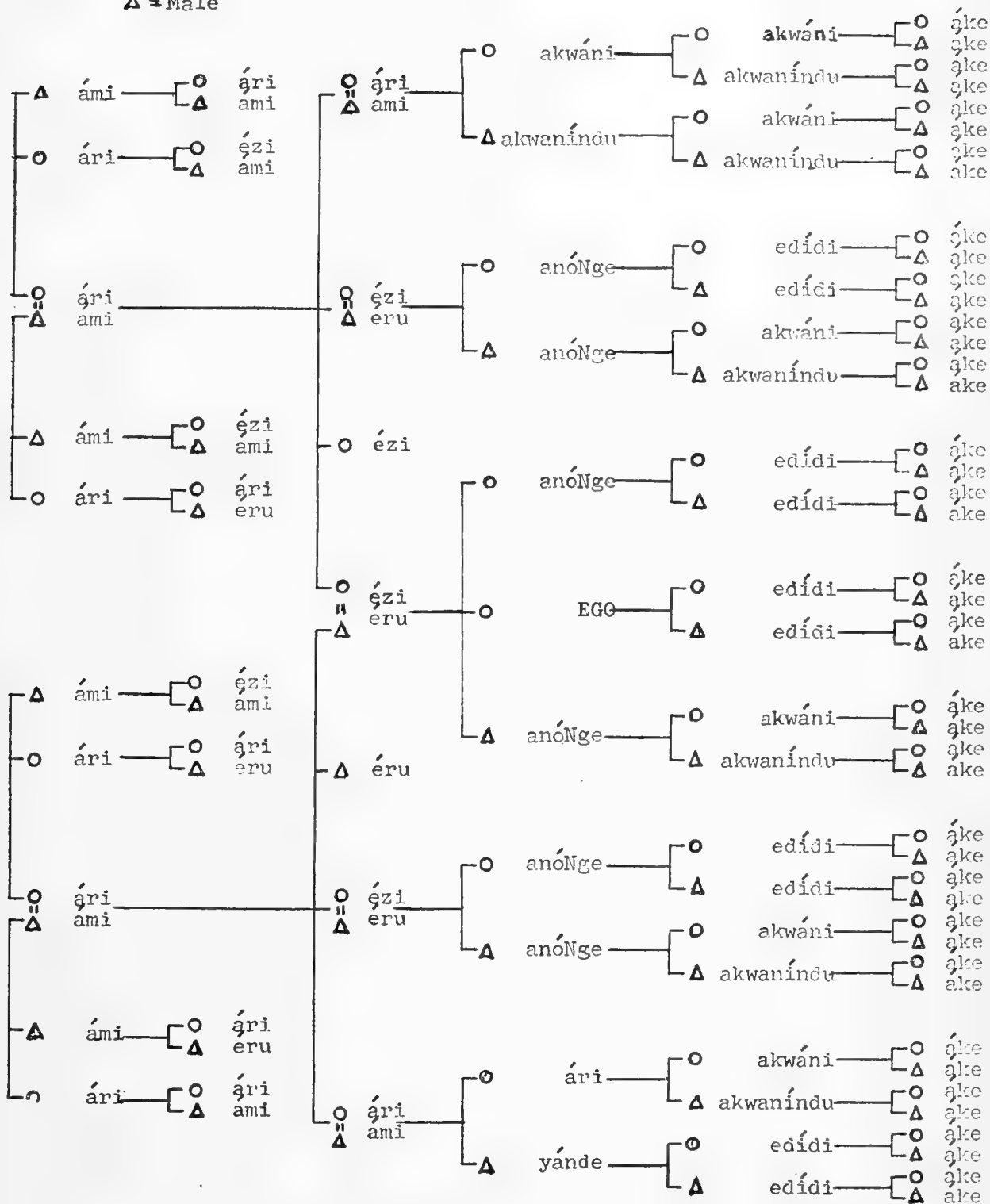

CHART 2.—Lineal kinship chart Siriono (female speaking).

siblings and parallel cousins of the opposite sex.

(7) No sex distinctions are made between grandson and granddaughter, or the children of nephews and nieces, all of whom are called by one term.

(8) There are no special affinal terms except the one for actual spouse.

(9) No age distinctions are made for any type of relatives.

○ = Female
△ = Male

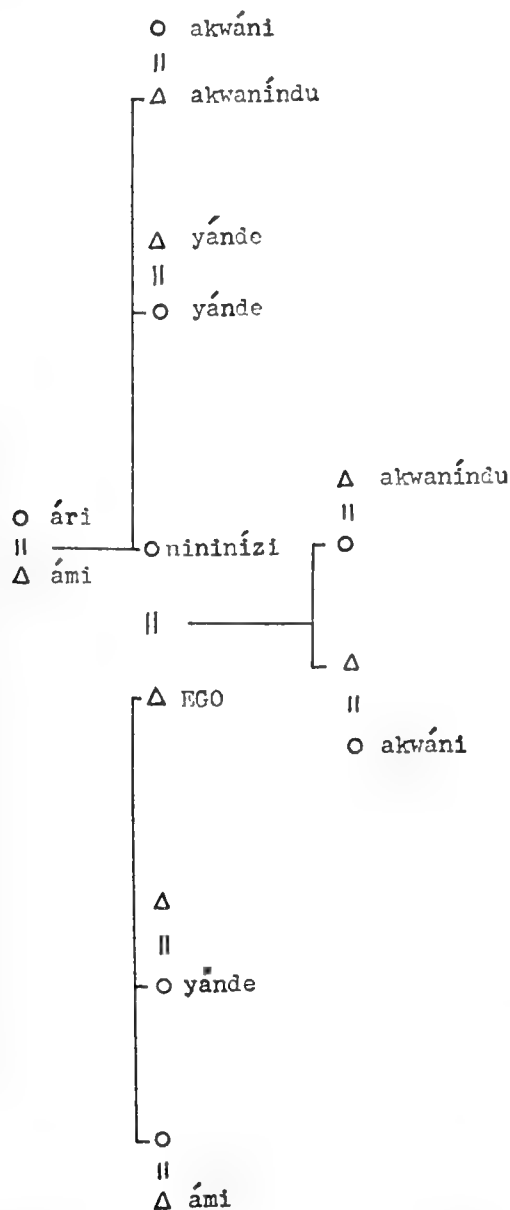

CHART 3.—Affinal kinship chart Siriono (male speaking).

○ = Female
△ = Male

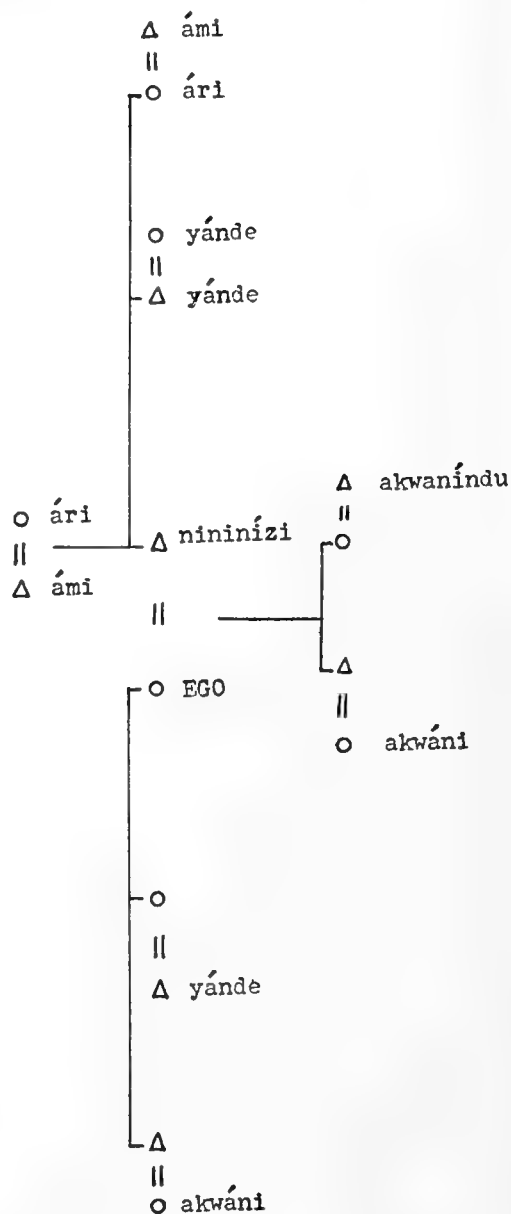

CHART 4.—Affinal kinship chart Siriono (female speaking).

KINSHIP BEHAVIOR

Generally speaking, there are no formalized, obligatory patterns of kinship behavior. Brother-sister avoidance, parent-in-law taboos, joking relationships, etc. are lacking. However, patterns of relative reserve and freedom are clearly noticeable between certain relatives.

Relationships between husband and wife are

free and easy. Sex play in the form of scratching, poking each other in the eyes, grooming, striking at each other's sexual organs, joking, etc., is publicly indulged in without concern.

Potential husbands and wives to some extent share the patterns of freedom that exist between husband and wife. This is especially true as regards the relations between a man and his wife's sister or a woman and her husband's brother. But as the nearness of relationship between potential spouses decreases, the patterns of freedom in their public relations also decrease. The principal reason for this seems to be the jealousies that arise out of too frequent sexual intercourse between distantly related potential spouses, which sometimes result in fights and quarrels. On the whole, however, the relationships between potential spouses are patterned along the lines of those actually existing between husband and wife.

Between parents and young children there is little reserve. The latter are treated very indulgently and are seldom punished for breaches of custom. As children grow older, however, they are expected to respect and to obey their parents, who treat them roughly in case they do not. A person's respect for his parents continues after marriage until the latter grow old and useless, after which little concern is shown for them.

A certain reserve can also be noted in the relationships between siblings of the opposite sex; this never reaches the point of avoidance, however. Brothers and sisters are allowed to speak freely to one another—and otherwise maintain cordial relations—but a taboo on sexual behavior between them is instilled in early childhood. The sexual taboos between brother and sister are generalized to include all relatives classed as siblings by the kinship system.

The freest relationships of all are those between siblings of the same sex and of about the same age. From earliest childhood brothers, like sisters, begin to associate with each other, and the close bonds established at this time continue and strengthen throughout life. Brothers frequently marry sisters; they have the same potential wives; they hunt, fish, and plant gardens together. Conversely, sisters frequently marry brothers; they have the same potential husbands; they collect, cook, and carry out household tasks together. Under conditions of this kind, of course, binding ties are formed, so that brothers often enjoy secrets

with brothers, and sisters with sisters, that are not even shared by husband and wife. Thus, throughout life one's most intimate friend and companion is most likely to be one's sibling of the same sex and of about the same age.

Grandparent-grandchild relationships are rare. When they do occur, a grandchild is supposed to show respect for his grandparents equal to that which he shows for his parents. In general, however, grandparents have little to say about how grandchildren are to be raised. A grandmother may weave a baby sling for her grandchild, or a grandfather may make a toy bow and arrows for his grandson, but such things are more often made by parents than by grandparents.

Although there are no taboos between parents-in-law and children-in-law, the relationships between these relatives are the most reserved of all. Because of matrilineal residence a woman is able to avoid most direct contacts with her parents-in-law, but a man, while in the house, is almost constantly thrown into contact with his parents-in-law by virtue of the fact that his (and his wife's) hammock hangs not 3 feet from theirs, with nothing more than a few embers of fire to separate them. Under these intimate and frustrating circumstances it is rather strange that no mother-in-law taboo has arisen to help in keeping peace between the families, but this has not happened. The fact of kinship ties—both husband and wife are related to their in-laws by blood—probably does much to lessen the friction that otherwise might arise between them.

While overt behavior between in-laws is usually polite and reserved, suppressed aggression sometimes runs high. This is particularly true in cases where a man is living with his mother-in-law whose husband is dead, for he then has to supply her with food without receiving anything in return. Widowed mothers-in-law have substantial appetites and contribute almost nothing to the family larder. Consequently their sons-in-law regard them as liabilities and avoid relations with them whenever possible.

Artificial ties of kinship such as blood brotherhood and ceremonial parenthood are absent. In this connection, the Franciscan priest, Anselm Schermair (1934, p. 520), has implied that the Siriono possess a form of godparenthood. He states that the term *yánde* is applied to people who stand in the relationship of godparent to one's

child. Actually this is not the case. As we have already pointed out, the term *yánde* is used to designate a potential spouse. What confused the padre and led him to mistake a potential spouse for a godparent is doubtless the following fact. In the ceremonies following childbirth, potential spouses of the mother—those who have had sex relations with her—are frequently decorated with feathers and undergo the rites of *couvade* like the parents themselves. This is logical enough in view of the fact that the Siriono recognize a very close relationship between parent and child and that one of the woman's potential husbands may, after all, have been responsible for the pregnancy. Moreover, if anything should happen to the parents of the child, those relatives who stand in a *yánde* relationship, i.e., those relatives who are potential spouses of the parents, are responsible for its upbringing and its care. In view of the circumstances, namely, that people of the opposite sex who stand in the *yánde* relationship have sex relations with one another, they can hardly be regarded as godparents in the usual sense of the term.

SOCIAL STRATIFICATION

Beyond the stratifications of sex and age, Siriono society is little differentiated as to status. A form of chieftainship does exist, but the prerogatives of this office are few. Such status divisions as castes, social classes, and specialized occupations are quite unknown.

Apart from age and sex, such status differences as do exist depend primarily upon how the duties of everyday life are performed. If a man is a good hunter, his status is apt to be high; if he is a poor provider, it is apt to be low. His status as a hunter, moreover, is enhanced considerably by his being a virile sex partner; having several wives is a mark of distinction. A woman's status, too, depends not only on her being active in the economic pursuits of the family but on her being a good childbearer as well. A childless woman stands at the bottom of the status hierarchy within the family.

Little status is gained through genealogy. Within the band, those people who are most closely related to the chief probably enjoy the greatest number of privileges, but I was unable to confirm this as an outstanding feature of Siriono society. It is probably true, to be sure, that the

brother of a chief enjoys more privileges than a distantly related cousin. But in a society like the Siriono, where the food supply is both scarce and insecure, a person's status necessarily depends more on his ability as a provider of food than on any other single factor. This was clearly brought home to me time and time again while I was at Tibaera.

One case deserves special mention. Enía (Knee) was the brother-in-law of Chief Eantándu. He had had some contact with the outside, but because of maltreatment had run away from his patron and returned to native life. He was an intelligent man with an unusual ability (for a Siriono) to adjust to white civilization. He was a hard worker and reliable, and he knew considerable Spanish. His one weakness was that he could not hunt as well as his countrymen. Time after time I saw him leave with his bow and arrows, and time after time I watched him return empty-handed, while his fellow tribesmen left after him on the same trail and returned with game. He was generally referred to as "not knowing how to hunt." He was openly insulted at drinking feasts for his inability to hunt. He had lost at least one wife to better men. His status was low; his anxiety about hunting, high. He had, however, made some kind of readjustment to native life by planting more crops and collecting more forest products than the others and trading some of his vegetable products for meat. But still he was not satisfied. Noting this condition, I set out to raise his status. First he accompanied me with his bow and arrows on hunting trips. He carried in game which I shot, part of which was given to him and which we told others was shot by him. His status began to improve. Shortly thereafter I taught him to use a shotgun, and he brought in game of his own. Needless to say, when I left Tibaera he was enjoying the highest status, had acquired several new sex partners, and was insulting others, instead of being insulted by them.

Several wives and numerous children are the principal status marks of a man. Similarly, to be married to a man who is a good hunter and to have several children are the most important status marks of a woman. Plural wives not only mark a man as a good hunter but as a virile sex partner as well. Men boast a great deal about their sexual prowess, as well as their hunting prowess, and in cases where they are married to

several wives they are careful to see that only allowable sex partners have any relations with them. Consequently, when overnight trips are made into the forest, a man generally takes all of his wives with him.

Rigidly marked age groupings are not found in Siriono society, although there is a recognition, as in most societies, of the categories of infancy, childhood, adulthood, and old age. Except in the case of the premarital rites for girls, the physiological changes that accompany maturation are little recognized or celebrated by special ceremony. As a mark of adulthood, however, men and women, after they are married and have children, are stabbed in the arms with the dorsal spine of a sting ray, which practice leaves scars that are signs of maturity. As a person grows older, bloodletting is continued—to rejuvenate him by getting rid of his old blood. The society thus seems to recognize that the sharpest break in age occurs between childhood and adulthood. The other transitions are very gradual and are not marked by ceremony.

It is difficult to generalize as to the status of women. Although they are dominated by the men, it can hardly be said that women occupy a position much inferior to that of the men when one considers the conditions under which this society exists. During childhood there is no noticeable preferential treatment of boys. On the basis of the sex division of labor the men do as much or more work than the women. Hunting is exclusively a task of the men, while collecting and agriculture are joint pursuits of both men and women. Women enjoy about the same privileges as men. They get as much or more food to eat, and they enjoy the same sexual freedom. They are not restricted from holding drinking feasts and dances, nor from participation in bloodletting ceremonies. After marriage, moreover, women continue to live with their parents and to enjoy the latter's protection.

CHIEFTAINSHIP

Presiding over every band of Siriono is a chief (*ererékwa*), who is at least nominally the highest official of the group. Although his authority theoretically extends throughout the band, in actual practice its exercise depends almost entirely upon his personal qualities as a leader. In any case, there is no obligation to obey the orders of a

chief, no punishment for nonfulfillment. Indeed, little attention is paid to what is said by a chief unless he is a member of one's immediate family. To maintain his prestige a chief must fulfill, in a superior fashion, those obligations required of everyone else.

The prerogatives of chieftainship are few. Although the title *ererékwa* is reserved by the men for a chief, if one asks a woman, "Who is your *ererékwa*?" she will invariably reply, "My husband." The principal privilege of a chief, if it could be called such, is that it is his right to occupy, with his immediate family, the center of the house. Like any other man he must make his bows and arrows, his tools; he must hunt, fish, collect, and plant gardens. He makes suggestions as to migrations, hunting trips, etc., but these are not always followed by his tribesmen. As a mark of status, however, a chief always possesses more than one wife.

While chiefs complain a great deal that other members of the band do not satisfy their obligations to them, little heed is paid to their requests. I was told, for instance, both by Indians and by whites who had had contact with them, that the chief was entitled to a share of every catch of game that was made. While I was living at Tibaera, I had an excellent chance to check this matter empirically, and I found that this was not, as said, usually the case, but rarely so. The more general rule was to avoid giving the chief anything, if possible.

The following is an example of the sort of thing that was constantly occurring at Tibaera. Kwáundu (Porcupine), a member of the band and extended family of Aćíba-eóko (Long-arm), the chief, was absent for several days with his younger brother on a hunting expedition. On returning to camp, they brought with them about a dozen tortoises of good size. These were tied up with lianas and hung on beams in the house, one or two of them being butchered each day. Aćíba-eóko, desiring meat, first made a direct request to Kwáundu, but was brushed off and given nothing. Following this he made public remarks without mentioning names that *mbía* (countrymen) were keeping all the meat to themselves and not giving any to him, the chief. The owners of the tortoises still paid no attention to him. Finally, after about 3 days, Aćíba-eóko, having received nothing, became so angry that he left for the hunt

with his family and stayed away for about a week. He returned with considerable roast meat which he distributed to no one else but members of his immediate family.

In general, however, chiefs fare better than other members of the band. Their requests more frequently bear fruit than those of others, because chiefs are the best hunters and are thus in a better position than most to reciprocate for any favors done them. In speaking of chiefs, both past and present, informants always referred to them as "big men." Chiefs know the most about hunting, about the habits of animals, about how best to surround a band of peccaries; they are the best composers of songs, the most powerful drinkers; they know the most about hunting tapirs and harpy eagles; they have the most wives and children. In short, chiefs know more about things and are able to do them better than anyone else. Consequently, they command more respect than the average man.

Chieftainship is normally a hereditary office and passes patrilineally from father to eldest son, provided the latter is a good hunter, is mature, and possesses the personal qualities of leadership. In case an eligible son is lacking, the office may pass to the chief's brother. It so happens that the chiefs whom I knew had both inherited the office from their fathers. One of them told me, however, that were he to die the office would be inherited by his younger brother, because he had no eligible son to whom it could pass.

LAW AND SOCIAL CONTROL

The legal system by means of which the relations between band members are governed is not an elaborate one. In such a simple society as that of the Siriono, most members of which are united by ties of blood, only a small body of customary law is needed to maintain what order does exist. Moreover, the social norms that prevail are elastic enough to allow for a considerable range of behavior, depending upon the immediate conditions of life. Thus, although one of the important legal norms is that of sharing food within the extended family, such sharing rarely occurs unless the supply of food is abundant. Frequently, in fact, food sharing does not go beyond the nuclear family, even though the quantity of food may be more than adequate to take care of immediate needs. Under such conditions, one may be

accused of hoarding food, but the other members of the extended family can do little about it except to go out and look for their own.

Within this society, the formal agencies of social control are almost entirely lacking. No such thing as a police force exists, and, as we have already seen, chieftainship, although theoretically an office of some power and distinction, is actually relatively unimportant as a means of controlling behavior. A chief does not interfere in the disputes of others, and when involved in disputes of his own, others pay little attention to them. Sorcery, moreover, is almost unknown as a means of social control. The handling of one's affairs is thus largely an individual matter; everyone is expected to stand up for his own rights and to fulfill his own obligations.

In spite of the extreme individualism of the Siriono in this respect, there are, nevertheless, certain incentives to conform to the legal norms that do exist. If, for instance, a person does share food with a kinsman, he has the right to expect some in return, and if a man does occasionally share his wife with a brother, he has the right occasionally to share that brother's wife. Reciprocity, however, is almost always forced, and is sometimes even hostile. One usually has to demand something in return for that which one has reluctantly given. Indeed, sharing rarely occurs without a certain amount of mutual distrust and misunderstanding; a person always feels that it is he who is being taken advantage of. Nevertheless, this type of forced reciprocity does seem to be one of the principal rewards of conformity.

So intense is the individualism of the Siriono and so elastic the legal system, that crime and punishment are rare. Murder is not condoned but is almost unknown. Only two cases, both of which happened a number of years ago, came to my attention. In one of these a man killed his wife with his bow and arrow during a drinking feast, and in the second a man killed his sister by throwing a club at her from a tree. In both instances the murderers were banished (or left) the band for a considerable time, but they returned later and resumed normal life.

Cases of premeditated murder were unknown. Informants told me, however, that under circumstances of this kind the *lex talionis* would be rigidly applied. Accidental homicide is not punished,

and other offenses against life, such as abortion and infanticide, seem to be unknown.

Minor assaults, resulting from quarrels that take place over food and sex or from those that arise during drinking feasts, are relatively common. While physical aggression against one another during quarrels meets with a certain amount of public disapproval, it usually goes unpunished. Assaults, however, often result in strained relations between the parties involved for some time after they happen.

The absence of rigidity in standards of morality makes for relatively few offenses in the realm of sex. Such crimes as incest and rape are rare. When they do occur, they are believed to be followed by an automatic supernatural sanction: the offender becomes sick or dies. Adultery, on the other hand, is common, and if committed discreetly frequently goes unpunished. If adultery occurs too often, however, an irate husband casts out his wife and she becomes subject to public ridicule. She is accused of being *e'imbási*, i. e., of having too strong sex desires.

Theft is unknown, except in the realm of food. Even the stealing of food rarely occurs because the conditions giving rise to the crime seldom exist: food is not plentiful, and one's immediate supply is hastily eaten. Some theft of food takes place at night, especially by the aged, but in instances of this kind the guilty parties receive no other punishment than that of being publicly accused of the crime, which they always emphatically deny.

Justice is an informal and private matter. Grievances are settled between the individuals involved, or among the members of the family in which they occur. Generally speaking, it would seem that the maintenance of law and order rests largely on the principal of reciprocity (however forced), the fear of supernatural sanctions and retaliation, and the desire for public approval.

INGROUP CONFLICT

One cannot remain long with the Siriono without noting that quarreling and wrangling are ubiquitous. Hardly a day passes among them when a dispute of some kind does not break out. Quarrels are especially common between husband and wife, between cowives, between sons-in-law and parents-in-law, and between children of an extended family, but they occur between all types of people,

relatives and nonrelatives. Quarrels are usually settled between the disputants who start them. This is especially true of those which take place in the nuclear and extended families. If a man is quarreling with his wife or mother-in-law, for instance, other people seldom intervene. If two members of different extended families become involved in a quarrel, however, relatives of the disputants may come to their aid. Children, for example, are frequently observed striking women with whom their mothers are quarreling, and brothers often come to each other's aid if they get involved in a quarrel outside of the family. The Siriono, however, maintain no arbiter of disputes. The chief, for instance, seldom takes part in settling differences that occur outside of his family.

Data were recorded on 75 disputes that came to my attention, apart from those that took place at drinking feasts. It is significant to note that 44 of them arose directly over questions of food (mostly between women or between husband and wife); 19 broke out over questions of sex (between husband and wife, cowives, and women); only 12 were assignable to various other causes. Here we have overwhelming evidence of the important role played by food in Siriono society. It is the most prominent cause of ingroup strife.

People constantly complain and quarrel about the distribution of food. They accuse each other of not sharing food, of hoarding food, of eating at night, and of stealing off into the forest to eat. This was particularly noticeable at Tibaera, where Silva and I made considerable effort to initiate cooperative planting of gardens—a custom foreign to the Siriono under aboriginal conditions. Several acres of land were cooperatively cleared and planted with maize. While the maize was ripening, bitter complaints were registered, and quarrels took place over its distribution, although there was plenty of maize for everyone. People accused each other of stealing maize before it was ripe, of harvesting more than they had a right to, of transporting it into the forest and eating it on the sly. Men complained that they had done most of the work, while the women were eating most of the crop. In fact, few men ventured on the hunt at this time for fear of returning to find that others had eaten most of the crop of maize.

Quarreling over the allotment of meat is equally common. While the distribution of meat is ordi-

narly confined to the extended family because the supply is seldom abundant, there is usually someone within the family who feels that he is not getting his share. Especially do the men accuse the women of hoarding meat, of eating it when the men are not around, or of consuming more than their share. Enfa said to me one night, "When someone comes near the house, women hide the meat; they cover it with leaves. When you ask them where the meat is they tell you there is none. They eat in the night and steal off in the forest to eat."

The reluctance to share meat is clearly reflected in the behavior of returning hunters. The bigger the catch the more sullen the hunter. The hunter adopts this pose so as not to be approached for game. On returning from the hunt a man sometimes does not even carry his game into the house but leaves it beside the trail near the house and comes in empty-handed, aggressive, and angry. Upon entering the house he throws himself into the hammock. This is the signal for his wife or whoever else is around to bring him a pipeful of tobacco, which he smokes without saying a word. If he has brought the game into the house, his wife sets about to prepare it; if it is still out in the forest, she goes out to retrieve it. The hunter maintains his unapproachable manner until after the game has been cooked and eaten.

Quarrels over sex can hardly be divorced from those over food. In this respect men seldom express aggression against other men who have seduced their wives but center it on their adulterous wives. Women, on the other hand, express little aggression against their adulterous husbands but channel it against the women who have caused their husbands to err. Women are thus believed to be the cause of most sexual disputes. Women may chide their husbands for being unfaithful, but the fact that the men always respond with more violent accusations that the women are unfaithful usually settles the dispute before it culminates in a violent end.

Drinking feasts are occasions on which much latent antagonism and aggression are expressed between men. At these feasts men openly air their complaints, whether these have to do with food, with sex, or with any other subject of contention. The disputes are settled by wrestling matches, and are usually forgotten after the period of drunkenness is over. It is interesting to note

that aggression at drinking feasts is limited to wrestling matches; any other type of fighting is frowned upon and is usually stopped by non-participant men and women. On one occasion Eantándu, when drunk, struck an opponent with his fists. Everyone began to clamor that he was fighting unfairly, "like a white man." He stopped immediately.

Except at drinking feasts antagonisms seldom lead to violence, and even at these the participants are usually so drunk that they are unable to harm one another. On other occasions strong words are used between disputants, but fighting with weapons and clubs is rare. This is especially true of the men, who seldom express direct aggression against each other, although among women quarrels frequently culminate in battles with digging sticks.

Men often dissipate their anger toward other men by hunting. One day Eantándu was angry with Mbiku who had hunted coati and given him none. Flushed with anger, Eantándu picked up his bow and arrows and departed for the hunt. When he returned about 5 hours later with a couple of small monkeys, his wrath had subsided considerably. He told me that when men are angry they go hunting. If they shoot any game their anger disappears; even if they do not kill anything they return home too tired to be angry.

If enmity between families becomes intense, one of them may migrate to the forest for a while until hostile feelings subside; if it becomes unbearable, one of them may split off from the band and join another band, or several extended families may break off from the band and start a new band of their own. Seldom are differences so deep and lasting, however, that this latter method of adjustment need be resorted to.

WARFARE

Contrary to popular misconception the Siriono are not a warlike people. In this respect such writers as Nordenskiöld (1911, vol. 57, pp. 16-17) have created a distorted picture of them. Warfare between bands simply does not exist, and where the Siriono have come in contact with other peoples, Indian or white, it is they who have been raided and rarely they who have done the raiding. In fact, the entire history of the Siriono, from what little we know about it, seems to reflect a strategy of retreat rather than one of attack. Whenever

they have come in contact with other groups, they have been forced to retire deeper and deeper into the impenetrable jungle in order to escape defeat, and in retiring from previously occupied lands they seem to have made few firm stands in defense of their territory.

The distribution of the Siriono today seems clearly to bear witness to this policy of withdrawal in the face of contact. The aboriginal groups that still survive are spread over an extremely wide area, and they are located in isolated pockets of forest lands that are most inaccessible and least desirable, where they have no contiguous relations with one another and where they are surrounded by hostile peoples. Only the fact that the Siriono adhere to a seminomadic mode of existence and that the unpopulated lands of eastern Bolivia are still extensive and relatively rich in food plants and animals has made it possible for the few of them who still survive in the forests to stay beyond the reach of civilization and extinction.

The best evidence we have for the relatively unwarlike character of the Siriono comes from the culture itself. Here are not found the organization, the numbers, or the weapons with which to wage war, aggressive or defensive. Moreover, war does not seem to be glorified in any way by the culture. The child is not educated in the art of war, nor is there a warrior class among the adults. Furthermore, the care with which the Siriono avoid contacts with other peoples and the fear with which they regard their more warlike neighbors bear witness to the punishment they have suffered as a group in the past.

Attention should be called, however, to the fact that on occasions the Siriono have retaliated for outbreaks against them by others. While they seem rarely, if ever, to have responded to the attacks made upon them from the south by the

so-called Yanaiguas, and from the north by the Bauré, for the purpose of killing their men and capturing their women and children, they have sporadically killed whites and missionized Guarayos Indians (with bows and arrows), both in retaliation for killings and for the purpose of securing iron tools and food. The warlike reputation of the Siriono, in fact, seems to have grown up as a result of these few isolated and unorganized raids, which reached their peak during the last rubber boom (in the 1920's) when there was a large influx of rubber tappers into some of the areas occupied by them. The *siríngueros*, whenever possible, ruthlessly murdered the Indians, who in turn occasionally retaliated by waylaying a rubber worker and dispatching him for his machetes and axes. But when the rubber boom ended in 1928, by which time the Siriono were probably in possession of an adequate supply of tools, most of the whites left the area and the raids stopped. Shortly thereafter peaceful contact was established by a few of the whites who remained in the region. Today the Siriono who wander in the vicinity of the Franciscan missions of Guarayos occasionally steal maize and manioc from the gardens adjoining them, but people are seldom killed as a result of these forays. Generally speaking, when the Guarayos have contacts with the Siriono, relations are cordial.

The enemies which the Siriono most fear today are the so-called Yanaiguas, who harass them in the south, and a small group of what are probably wild Bauré, who sometimes attack them in the north. Almost nothing is known of these two groups of Indians, except that they are unfriendly and warlike. Both tribes are equated by the Siriono under one term, *kurúkwa*, a kind of monster, and are carefully avoided by them whenever possible.

THE LIFE CYCLE

SEX*

Romantic love is a concept foreign to the Siriono. Sex, like hunger, is a drive to be satisfied. Consequently, it is neither much inhibited by attitudes of modesty and decorum, nor much enhanced by ideals of beauty and charm. The expression *šěčubi* ("I like") is applied indiscrimi-

nately to everything that is enjoyable, whether it be food to eat, a necklace to wear, or a woman.

Although love is not idealized in any romantic way, there are certain ideals of erotic bliss, and a certain amount of affection exists between the sexes. This is clearly reflected in the behavior that takes place around the hammock. Couples frequently indulge in such horseplay as scratching and pinching each other on the neck and chest,

*Considerable material relating to sexual behavior was expurgated from the original manuscript.—EDITOR.

and poking fingers in each other's eyes. Lovers also spend hours in grooming one another: extracting lice from their hair or wood ticks from their bodies, and eating them; removing worms and spines from their skin; gluing feathers into their hair; and covering their faces with uruku (*Bixa orellana*) paint.

Since privacy is almost impossible to obtain within the hut where as many as 50 hammocks may be hung in the confined space of 500 square feet, more intercourse takes place in the bush than in the house. Relations also occur at night in the hammock, but more rarely so.

Generally speaking, great freedom is allowed in matters of sex. A man is permitted to have intercourse not only with his own wife or wives but also with her (their) sisters, real and classificatory. Conversely, a woman is allowed to have intercourse not only with her husband but also with his brothers, real and classificatory, and with the husbands and potential husbands of her own and classificatory sisters. Thus apart from one's real spouse, there may be as many as 8 or 10 potential spouses with whom one may have relations. There is, moreover, no taboo on relations between unmarried potential spouses, provided the women have undergone the rites of maturity. Virginity is not a virtue. Consequently, unmarried adults rarely lack sexual partners. In actual practice, relations between a man and his own brothers' wives, and between a woman and her own sisters' husbands, occur frequently and without censure, but those with potential spouses more distantly related occur less often and are apt to result in quarrels or lead to divorce.

Food is one of the best lures for obtaining extramarital sex partners, and a man often uses game as a means of seducing a potential wife. Failures in this respect result not so much from a reluctance on the part of a woman to yield to a potential husband who will give her game, but more from an unwillingness on the part of the man's own wife or wives to part with any of the meat that he has acquired, least of all to one of his potential wives. In general, the wife supervises the distribution of meat, so that if any part of her husband's catch is missing she suspects him of carrying on an affair on the outside, which is grounds for dispute. Hence, instead of attempt-

ing to distribute meat to a potential wife after game has already been brought in from the forest, a man may send in some small animal or a piece of game to the woman through an intermediary, and thus reward her for the favors he has already received or expects to receive in the future.

Fights and quarrels over sex are common but occur less often than fights over food. As has been pointed out, such quarrels arise largely as a result of too much attention to a potential spouse to the neglect of the actual spouse; this is really what adultery amounts to among the Siriono. However much men are chided by their wives for deceiving them, this seems to have little effect on their behavior, for they are constantly on the alert for a chance to approach a potential wife, or to carry on an affair with a *yukwáki* (young girl) who has passed through the rites of puberty. In plural marriages, however, I rarely noted pronounced jealousy between the wives, possibly because most plural marriages are of the sororal type.

In all these relations, basic incest taboos must be strictly observed. That is to say, it is strictly forbidden to have intercourse with any member of one's nuclear family, except one's spouse. Among the Siriono these incest taboos are generalized to include nonfamily members who are designated by the same kinship terms as those used for members of the nuclear family. Consequently, one may not have relations with a parallel cousin, with the child of a sibling of the same sex, with the child of a parallel cousin of the same sex, with a sister or parallel cousin of the mother, with a brother or parallel cousin of the father, or with the child of anyone whom one calls "potential spouse." In addition to these taboos, which are clearly reflected in the kinship system, relations with the following relatives are also regarded as incestuous: Grandparent and grandchild, parent-in-law and child-in-law, uncle and niece, aunt and nephew, a woman and her mother's brother's son, and a man and his father's sister's daughter.

Violations of incest taboos are believed to be punished by the supernatural sanction of sickness and death. However, I never heard of a case of incest occurring among the Siriono, even in mythology. The reason for this probably lies in the fact that the sex drive is rarely frustrated to

such an extent that one is tempted to commit incest.

Atypical sex behavior is also rare. Insofar as I could tell, only one man showed any tendency toward homosexuality, but this never reached the point of overt expression. He had never had a wife, and spent most of his time with the women. He lived next to his only brother, was regarded as harmless, and made his living largely by collecting and trading some of his products for meat. Another man was accused by the women of being sadistic and for this reason had no wife. His nickname was Etoni (Lazy), one which he had received because of the following ingenious device. He was an expert at tracking tortoises. He would gather as many as 10 of them at a time and hang them up alive on a beam in the house. He would then butcher one or two each day, meanwhile resting in his hammock, until the supply was gone. He spent long periods of time alone in the forest, and was one of the few Siriono out of whom I could worm no information whatsoever.

Chastity not being a virtue, there are few occasions when sex is taboo among the Siriono. During menstruation sex relations are forbidden, but during pregnancy they are recommended and indulged in up until shortly before delivery. Following childbirth, a woman refrains from intercourse for about a month, but there is no prescribed period after delivery that she must abstain. Following the death of a spouse, a widow or widower may resume sex relations within a matter of 3 days. There are, moreover, no other ritual or ceremonial occasions when adults are restricted from participation in sexual activity.

REPRODUCTION

With respect to conception, there is no lack of knowledge that it is caused by sexual intercourse. All informants agreed that a woman could have a child by no other means. But no crystallized theories of how the process takes place have been formulated. Constant interviewing on this subject yielded nothing but negative results.

The relationship between menstruation and pregnancy is also clearly recognized by the Siriono, but again their ideas on these matters have not attained crystallized form. Informants were convinced that women had to menstruate before they could have children, but they were unable to supply any of the reasons why. My

investigation on these questions, moreover, led me to the conclusion that the Siriono do not correlate the menstrual cycle with the lunar cycle in any special way.

In a certain sense a distinction is made between menstrual blood and ordinary body blood. The former is always designated as *eréN erúki* (vagina blood), while the latter is simply referred to by the general term *erúki* or "blood." What the differences between them are, however, the Siriono are quite unable to explain except in the vaguest sense. Contact with menstrual blood, especially in sexual intercourse, is regarded as harmful, while contact with ordinary body blood is considered innocuous.

Although menstrual blood is looked upon as something dangerous to the Siriono, they have not developed attitudes of disgust or horror toward it. During menstruation women wear nothing; they are neither isolated from the rest of the group nor restricted from participation in such household activities as cooking that bring them into intimate contact with other people. While menstruating women bathe more often during the menstrual period than at other times, they are not subject to food taboos and are not even required to sleep apart, although no sexual intercourse is indulged in at this time. All of my male informants told me that they had never had intercourse with a menstruating woman and that to do so was very dangerous, but there were varied opinions as to what might happen to those who did. It was generally thought that they would become "blood sick" and die.

One of the principal signs of pregnancy is the cessation of the menses. If a woman has never before been pregnant, however, some doubt may be expressed as to whether she is going to have a child until her breasts begin to swell.

Few other signs of pregnancy seem to be recognized. An extended abdomen is an unreliable sign; most of the Siriono women have distended stomachs from the habit of overeating when they can. Morning sickness also does not seem to be regarded as a pregnancy sign; at least, I was unable to get any recognition of it or observe any cases of it among the pregnant women whom I interviewed.

In some cases a woman may know that she is pregnant because she has dreamed it. One morning Eantádu told me that his wife was with child.

Since she showed no outward signs of her condition, I asked her how she knew that this was true. She replied that she was certain of it because the night before she had had a dream that she had a very small child inside of her. Upon interviewing her further, however, I found that this dream merely corroborated excellent physiological evidence for her pregnancy, namely, that she had not menstruated for some time.

Once a woman is pregnant, the Siriono have no methods of divining the sex of the child or of forecasting the time of its delivery. When first conceived, the child is believed to be a miniature replica of the infant at the time it is born, and intercourse is thought to stimulate the growth of the infant in the mother's womb. Thus intercourse is desirable throughout pregnancy.

Except for being subject to certain food taboos, the normal life of a woman is little upset during pregnancy. She goes about her regular work until shortly before the time of her delivery. She may not eat coati lest the infant be born with sores and a very long head. The guan, the howler monkey, the macaw, and the toucan are taboo on the grounds that if they are eaten the infant will cry a great deal when it is born. Likewise forbidden is the meat of the armadillo. A violation of this taboo will cause the infant to have great fear like the armadillo, which crosses its arms in its hole when it is caught. Other forbidden foods include the owl monkey, whose meat cannot be eaten lest the infant inherit its tendency not to sleep at night; the anteater, porcupine, and honey bear, lest the infant be born clubfooted; the jaguar, lest the infant be still-born; turtle eggs, lest the mother have a miscarriage or be unable to deliver the infant and die; and the harpy eagle, because it is taboo for all people except the aged.

Some of these food taboos are generalized to the father, but not all of them. The only ones which he usually observes are the restrictions on eating harpy eagle, anteater, and howler monkey, which in a strict sense are not pregnancy taboos, since these animals are never supposed to be eaten by anyone but an old person. However, these food taboos seem to be more carefully observed by the men when their wives are pregnant.

Both the pregnant woman and her husband are also careful not to eat a double ear of corn or a double root of manioc lest twins be born. They

likewise avoid eating twisted or deformed plants of any kind lest this characteristic be transferred to their offspring in the form of clubfeet.

A woman's diet during pregnancy, however, is not much reduced by the above-mentioned food taboos. She is allowed to eat all vegetable foods, fruits, and fish. In addition, she still has a wide selection among meat foods, of which the following are the principal ones: tortoise, turtle, curassow, duck, cormorant, spider monkey, capuchin monkey, squirrel, peccary, tapir, agouti, capybara, paca, alligator, hawk, vulture, and marsh deer. Such animals as the tapir and peccary are especially favored because they are regarded as valiant and industrious, and if their flesh is eaten one's children will grow up to be like them.

Neither abortion nor infanticide is practiced, and miscarriages seem rarely to occur under aboriginal conditions. During my residence in Casarabe, however, where the Indians were living under rather brutal conditions of forced labor, three instances of miscarriage came to my attention. These were caused, according to my native informants, by the fact that the pregnant women were compelled to work beyond their endurance. Under aboriginal conditions, however, miscarriages are generally attributed to the breaking of food taboos, such as the eating of turtle or tortoise eggs. In the case of a miscarriage, the infant and all remains of the birth are thrown away into the bush without ceremony, but the mother and father must undergo a 3-day period of mourning, in which they are scarified on the legs and feathers are put in their hair.

To prevent the occurrence of miscarriage a woman must be careful not to eat the flesh of an animal to which some parallel experience has happened. One day Ndekai, one of my male informants, had several tortoises hanging by lianas from a beam in the house. Early in the morning of the following day it was found that one of these tortoises had "dropped" her eggs on the floor during the night, and that they were broken. The tortoise was cooked and eaten immediately, but Ndekai's wife would have no part of the flesh. She told me that if she partook of any of this tortoise she would have a miscarriage—that she would "drop" her child in the same manner as the tortoise had "dropped" its eggs.

The Siriono also recognize that under extreme conditions of fright miscarriages are more likely

to occur. One interesting instance of this kind, although it was not observed by me, came to my attention while I was living in Tibaera. Sometime in 1938 one of the amphibian planes of Lloyd Aéreo Boliviano, the Bolivian national airline, got lost in a storm between Cochabamba and Trinidad and for lack of gas was forced to land on an uncharted lake in the Siriono country. It so happened that Erésá-eánta (Strong-eyes), his five wives, and their children were camped on this lake at the time, hunting, fishing, and tending a small garden plot which he cultivated there. It was probably the first time that an unacculturated Siriono had ever seen an airplane; in any event, Erésá-eánta and his family were unacquainted with such a phenomenon.

As Erésá-eánta described the event to me, he was returning from the hunt late one afternoon to his house, which was situated near the shores of the lake, when he heard a buzzing sound some distance away. As it became louder he got frightened and hurried on to the house. When he arrived there, he saw a huge *ngidadiša* (harpy eagle, his term for the plane) swooping down on the lake. When it had settled, people got out of its "stomach." He and his family were immediately seized with terrific fright and took to the bush, carrying with them nothing but their hammocks and fire. Upon arriving at a water hole some distance away, they were overcome by darkness and were forced to camp for the night. Sometime during the night, one of his wives who was pregnant—Kiré was her name, and she verified the story—had a miscarriage, "because she had great fear." The remains of this abnormal birth were thrown away into the bush. On the following day Erésá-eánta's wives proceeded to another camp, while he cautiously approached the lake again to pick up some of the supplies left there. Upon arriving, he found that "*ngidadiša*" was still there, and he watched it for some time while hidden in the brush near the shore. Before noon of the same day the "father" of the "*ngidadiša*," i. e., a larger plane, flew over the spot but left immediately. Erésá-eánta remained concealed in the brush. Later in the afternoon a "brother" of the first "*ngidadiša*," i. e., a plane like it, circled overhead and landed near it. This also had people in its "belly." After the people conversed for some time, both of the planes went off together, and he never saw them again. He said that he returned to his

family the same afternoon, but that he did not come back to the lake for a long time afterward. More than 3 years later I had the good fortune to spend considerable time with one of the worried passengers of that plane, Señor Medardo Solares A., who substantially confirmed the events as recounted to me by Erésá-eánta.

CHILDBIRTH

Childbirth normally takes place in the hut and is a public event. Births are well attended by women and children but rarely by the men, who display little interest in such matters. If a birth takes place during the day, even the prospective father will not be present because as soon as a woman begins to feel birth pangs she notifies her husband and he departs for the hunt to seek a name for the child.⁵

The coming of labor pains necessitates certain preparations for the birth. These are usually made by the woman herself. Since parturition takes place in the hammock, she ties a rope (*éčo-séko-sákwa*, "childbirth rope") above it, so as to have something secure to grasp during labor. She also loosens the hard ground under the hammock with a digging stick so that the child will have a soft bed on which to be born. Sometimes she also spreads ashes over the soft earth further to cushion the newborn infant. Having finished these preparations the woman lies down in the hammock where she awaits the birth with grunts and groans to which her tribesmen pay little attention.

Of the eight births which I had the good fortune to witness among the Siriono, four took place during the day and four at night. In the former cases the mothers received no help whatever, either during the preparations for the births or during the births themselves. In the other four cases the husbands assisted to the extent of setting fire to a few dried leaves of motacú palm in order to light up the immediate environs of the hammock, but beyond this they gave no help. At all of the births a crowd of women were present, standing by or sitting in adjoining hammocks, gossiping about what it was like when they had their last child or speculating as to whether the prospective child would be a boy or a girl. Not a move was made by these onlookers to assist the parturient women, except in one case when twins were born.

⁵ See Naming, p. 74.

In all of the births which I witnessed, except that of the twins, the mothers had no difficulty in delivery. The time of labor varied from 1 to 3 hours, but never extended beyond that limit. In all instances the babies were born head first.

To exert force during labor a woman grasps the rope strung above her hammock. The infant, in being born, slides off the outside strings of the hammock on to the soft earth below. Since hammocks are not hung more than a few inches above the floor, the shock to the infant of falling to the ground is not great, yet it is probably sufficient to start it breathing and induce it to show other signs of life. In no case did I see an infant slapped to give it life. All of them started breathing immediately after the shock of birth.

Immediately after the birth the mother gets out of her hammock and kneels on the floor to one side of the infant until the afterbirth is expelled. In all of the cases which I witnessed the afterbirth was expelled in a matter of 10 minutes, but if a woman experiences any difficulty in this matter she is pounded on the back until it does come out.

The proceedings which follow depend to some extent upon whether the birth takes place at night, when the father is present, or during the day, when he is off on the hunt. If the father is present the umbilical cord is cut at once; if not, the mother must await his arrival. The cord is cut by the father with a bamboo knife. After taking a bath he squats on the floor by the infant. The mother then hands him a piece of bamboo, and while she holds the cord away from the placenta, he cuts it about 4 inches from the placental end. After this the mother holds up the cord and the father cuts off a section about 6 inches in length, which is tied to the under side of the hammock to prevent the infant from crying. The remainder of the cord, about 8 inches, is left attached to the infant and is not tied. After all of these proceedings, during which not a word is said, the father returns to his hammock to commence the observance of the couvade. If he has not been present at the birth, the same customs are followed after he returns from the hunt.

Immediately after the afterbirth has been expelled, the mother picks up the newborn infant and begins to scrape the dirt and ashes from its skin and hair with her hands. While thus cleaning the baby she also slightly presses its head from

front to back, and its hips inward, so as to make it *etúra* (beautiful). For a couple of days immediately following childbirth, about every half hour or so, the mother can be observed pressing the infant's head and hips in this fashion to make it beautiful. Having cleaned the baby she gives it a perfunctory bath, from a calabash, after which it is offered suck—usually less than half an hour after birth.

After the baby has been bathed and suckled, the mother begins to clean up the afterbirth which lies under the hammock. No one but she has any contact with this bloody mess. She sits on the ground with the baby in her arms and with one hand scrapes up all evidence of the birth into a pile. This is shoved temporarily into a hole in the ground or placed in a basket, and about 2 weeks later is taken deep into the bush and thrown away. A mother sits on the ground, tending her baby, for about 8 hours following the birth before she again enters her hammock.

For about 3 days following childbirth the Siriono family undergoes a series of observances and rites which we may loosely term the couvade. These rites are designed to protect the life of the infant and to insure its good health. Not only is the infant believed to be extremely delicate during the period immediately following birth, and thus readily subject to disease and death, but it is thought still intimately to be connected with the parents and profoundly to be affected by their activities. Consequently the latter are restricted in various ways. Except for satisfying the calls of nature they do not move outside of the house. They stay close to their hammocks, and are subject to a number of food taboos. Neither jaguar nor coati is eaten lest the infant break out with sores all over its body; paca cannot be eaten or the infant may lose its hair; papaya cannot be eaten lest the infant become a victim of diarrhea. Parents do not suffer much during this period, however, as there is a long list of foods which they can eat: guan, agouti, monkey, tapir, deer, peccary, tortoise, fish, manioc, maize, etc. Some informants told me that maize was taboo during the couvade period—to prevent the infant from having pains in the stomach—but since I never saw this taboo observed it is probably not a functioning one.

More important than the abstinence from certain foods is the carrying out of certain other

practices that must follow the birth of every baby. On the day after the birth both parents are scarified on the upper and lower legs with the eye tooth of a rat or a squirrel. Usually the father is scratched first. No particular relative or person is responsible for performing this operation, though in the case of the mother it is usually done by the husband. Before the husband is scarified he puts on a necklace or two of coati teeth and winds the new baby sling, which has been covered with uruku, around his neck. He stands by his hammock during the operation. The person doing the scarifying squats down and makes long scratches on the outside of the upper legs from the hips to the knees and on the back and outside of the lower legs from the knees to the ankles. As these scratches are relatively superficial, not a great deal of blood flows. Immediately after the operation is finished the legs are washed and covered with uruku.

After the husband has been scarified, he removes the baby sling and the necklaces; the mother then puts these on and undergoes the same operation, usually at the hands of her husband. While the mother is being scarified, the baby is left lying in the hammock or is held by a cowife or sister. According to the Siriono, this practice of scratching the legs has the purpose of getting rid of old blood, which might cause the child to be sick. It might thus be regarded as a purification rite.

Except during the scarification rite the parents stay close to their hammocks on the day following the birth, the father resting and the mother attending the infant. They do little cooking themselves, but are fed by other members of the extended family. There is, however, no taboo on their doing some cooking, and occasionally one sees a mother or father roasting an ear of corn or a root of manioc in the fire at this time.

The most significant thing that happens to the infant on the day following its birth is that it gets its first haircut in the traditional style of the band. This consists in depilating the forehead to a high semicircle. Since this operation is a very painful one, the mother usually pulls out a few hairs at a time and then lets the infant calm down for a half hour or so before continuing the operation. Actually it is a very frustrating experience for the young baby, who struggles its utmost to avoid the pain. Nevertheless, by the end of the second day the infant is without eyebrows, and

the hair on the front part of its head has been pulled out. The removed hair is saved, wrapped in cotton string, and covered with beeswax. It is then made into a necklace, which the mother ties around her neck to promote the growth of the infant's hair.

The second day after the birth of the child is spent in ornamenting the parents with feathers. Both are decorated in exactly the same way. A cowife or potential wife of the father usually performs the task. Again the man is usually decorated first. After the hair is trimmed, red and yellow feathers of the toucan are glued into the hair at the front of the head, tufts of curassow down covered with uruku are glued into the hair over the ears, and tufts of breast down of the harpy eagle (also covered with uruku) are glued into the hair at the back of the head. In addition to these feather ornaments in the hair, both parents are decorated with new cotton string covered with uruku. This is wound around the legs just below the knees, around the arms above the elbows, and around the neck. The face, arms, and legs are then smeared with uruku and the decoration is complete.

These decorations are sometimes applied to other members of the family, especially to a cowife or, in the case of a multiple birth, to either the cowife or sister of the mother who is designated to take immediate care of one of the babies. In such instances the cowives are decorated in the same fashion as the parents. In two of the cases which I observed, boys of about the age of puberty and standing in the *yánde* or potential spouse relationship to the mother also underwent the same ceremonies as the father, doubtless because they, too, had been having intercourse with the mother before and during pregnancy. The relationship between the parents and the child is thus generalized to coparents as well. Children and other members of the family, however, are not decorated, although a feather or two may be added to their hair while the parents are being adorned.

The parents undergo no further rites on the second day after birth, but there still remain the ceremonies that terminate the *couvade*. These usually take place on the third day after birth, although they are sometimes postponed until the fourth, but they do not depend on any particular circumstances, such as the dropping off of the circumcord. In these terminal rites uruku is again

smearred on the members of the family undergoing the *couvade*. Necklaces made from the base of the quill feathers of a species of hawk are placed around the necks of the father and mother. The mother by this time is also wearing a necklace containing the hair plucked from the infant's head. A few miniature baskets with a very open weave are hastily woven by the mother from a leaf of *motacú* palm and filled with the ashes of a dying fire. She then takes up the baby and places it for the first time in the new sling, which is dyed bright red with *uruku*. The father picks up his bow and a couple of arrows, and the family starts off on a trail into the forest. As a rule, but not always, the father marches ahead, carrying his bow and arrows to protect the infant from danger. The mother follows behind, with the baby in the sling, carrying in one hand a basket of ashes, which she slowly scatters along the trail to purify it, and in the other a calabash of water. If there are any other children in the family, or cowives or *yánde*, they may also join the party and scatter ashes along the trail. Usually not a word is said as the party proceeds to its destination. After walking for about 5 minutes the entire group halts. The mother sits down, and her husband brings her a palm leaf from which she begins to construct a carrying basket. The father in the meantime goes in quest of firewood. After firewood has been collected and placed in the basket, the party starts home without ceremony. When they arrive about 100 yards from the hut, the baskets which contained the ashes are hung on to bushes a few feet from the trail. Upon entering the hut the parents kindle a new fire with the wood carried back from the forest. The infant is then given a bath from the calabash of water which the mother took into and brought back from the forest. The period of *couvade* is then considered to be officially over, and the normal activities of life can be resumed.

MULTIPLE BIRTHS

The Siriono regard multiple births as unnatural. Twins are believed to be caused by the father or the mother having eaten a double ear of corn. In fact, any plant which grows double, such as maize, manioc, or camote, is carefully avoided by adults lest multiple births result. Such plants are always fed to children. Although twins occur occa-

sionally, informants knew of no cases in which more than two children were born at one time.

When twins are born, both are allowed to live. One of them frequently dies, however, because the mother is unable properly to attend both. Although cowives or sisters having no young children usually suckle one of a pair of twins for a short time after birth, there is, except in the case of orphans, a considerable reluctance to take care of anyone else's child for any prolonged period.

A CASE OF TWINS

The following are observations on the birth of a pair of twins at Tibaera on the night of January 17, 1942. Up until the time of the birth, of course, no one had expected a pair of twins—the parturient mother, *Eakwantú* (*Tapir*), least of all. Before the birth she had assured me time and again that she would have but one child.

In the case of this pair of twins, the first signs of birth appeared almost a month and a half before the children were actually born. About 6 a. m. on December 1, 1941, the woman began to feel labor pains and informed her husband. He, following the Siriono custom, picked up his bow and arrows and went out to hunt.⁶ The usual preparations were made for the birth, such as loosening the earth underneath the hammock and hanging up the childbirth rope. After an hour or so, however, labor pains subsided, and the woman went about her usual duties in the house. At noon she smearred some *uruku* on her face to facilitate the birth, but by the time her husband had returned from the hunt nothing further had happened. He had secured four toucans and two squirrels. These were eaten by him and the families of his in-laws, but his wife did not eat any of these animals as they were taboo to her.

After the first labor pains, life proceeded normally, the prospective father and mother, however, remaining close to the house. On December 4, at about 2 p. m., *Eakwantú* again began to feel labor pains. Again her husband picked up his bow and arrows, and preparations were made for the birth. On this day labor pains were considerably stronger than before. *Eakwantú* lay in her hammock in great pain, muttering "*šedídi erási*" ("I am child sick"). As her cries got louder, most of the women of the band gathered and sat down in

⁶ The reason for this is to secure a name for the child. See Naming, p. 74.

neighboring hammocks. Children were also present, boys and girls as well as babes in arms. No men were intentionally present, although some lay nearby in their hammocks, paying no attention to the proceedings. After about 10 minutes of waiting for the birth to take place, someone at the other end of the house announced the arrival of a party with manioc brought in from an old garden some distance away. The suffering woman was immediately abandoned; everyone made a rush to see whether he could get some manioc. In a short while the labor pains ceased, and at about 6 p. m. Eakwantú's husband returned from the hunt with a squirrel, which was eaten by his sister.

Nothing further happened, except that the prospective parents had occasional intercourse to hasten the delivery of the child, until December 17, when Eakwantú again began to feel labor pains about 7:30 in the morning. Her husband stretched the childbirth rope over the hammock before going out to hunt. Tatú (Armadillo), the husband's sister, swept the floor under the hammock and loosened the earth with a digging stick. An old woman, not an immediate relative, performed a solo dance at the head of Eakwantú's hammock to facilitate the birth. Again present were most of the women and children of the band. After about an hour the birth pangs subsided for the third time. At nightfall Eakwantú's husband returned with a small tortoise, which was eaten by his brother-in-law.

Between December 17 and January 17 there was no further progress toward labor, but there was considerable talk on the part of the other women, who expected that Eakwantú would die. On the whole, however, they paid little attention to her, although her sister-in-law, Eičazi (Mother-of-Clubfoot) said to me, "*kóse móse mbía máno akendási*" ("People have died in childbirth before"). During this period both Eakwantú and her husband stayed close to camp. He did not go hunting for more than a day at a time, and the only times she left camp were to have intercourse to stimulate the birth of the infant.

Finally, on January 17, at about 3 o'clock in the afternoon, Eakwantú again began to have labor pains. Because of the previous false alarms almost no attention was paid to her at first. Her husband went hunting as usual, although he explained that it was too late in the afternoon to get game. About 5 p. m. the labor

pains began to grow stronger, and Eakwantú's sister-in-law began to rub her stomach a little. She herself was pulling and rubbing her breasts during the pains. This time her husband's sister's husband tied a piece of pole over the hammock with lianas, and she grasped on to this for support while trying to give birth. Receiving very little attention, she continued in pain until about 5:30 p. m., when her husband returned from the hunt with a small turtle. This was immediately prepared and eaten by one of his sisters-in-law. A girl child was finally born about 7 p. m., dropping through the strings of the hammock, and about 3 minutes afterward, a boy. As soon as the girl was born, the father got out of his hammock and assisted Eakwantú by supporting her under the arms. When the boy was born, there was terrific confusion among the women, who crowded so close to the mother that she could hardly breathe, but none made an effort to help her. After the second birth the mother got out of the hammock to expel the afterbirth. Both children were lying in the dirt underneath the hammock, showing few signs of life. The mother appointed Araia, a cowife, to take care of one of the children. When Araia picked up the boy, all the women cried, "*Dézi eráNkwi*" ("penis for the mother," i. e., the boy for the mother), so she put the boy down and took up the girl. The mother, who had expelled the placentas in the meantime, called for a basket. From it she took a small blade of bamboo and handed it to her husband. He first severed the cord of the girl about 2 inches from the placenta and then cut off a piece about 4 inches long, which Araia, the second wife, put on her leg before tying it under her hammock. The cord of the boy was then cut in the same manner. It was now about 8 p. m., and almost everyone who had been observing the birth, retired to his hammock to sleep.

After the rest had left, the mother and Araia remained seated on the ground with the two children. The mother began to scrape up the bloody earth from underneath the hammock with her hands, pushing it into a small hole which her sister-in-law, Tatú (Armadillo), had made for that purpose near the head of the hammock. When all of the blood-stained earth had been placed in the hole, the mother carefully put the two placentas on top. Then both of the women began to shape the children, first straight-

ening their legs, then pushing their hips inward, and finally pressing their heads slightly from front to back—"to make them beautiful," as Araia told me. Both infants were then given a hasty bath from a calabash of water, after which the two women, sitting on the ground, gave the babies suck. When I retired, at about 2 a. m., both women were still attending the infants and sitting in the same position they had assumed after the birth.

On the following morning, January 18, I returned to the hut about 6 a. m. The mother was then holding both of the infants, but when I came into the hut, she passed the female to Araia. The mother had not yet taken a bath; the blood from the birth was smeared all over her legs. Her husband was lying in the hammock, eating maize. The women spent some more time in shaping the limbs and pressing the hips and heads of the infants and then gave them a bath. Eakwantúí and Araia next began to eat roasted maize prepared for them by the 8-year-old daughter of the former. After eating the maize, the two women were brought some fruits of the aguaf and motacú. They continued to roast and eat until about 2 p. m., when they entered their hammocks for the first time since the birth the night before. At 8 o'clock that evening both women were still fast asleep in their hammocks with the infants upon their breasts. The father had lain in his hammock all day.

About 8 a. m. on January 19 the father took a bath in the river. When he returned, Eakwantúí placed two baby slings—newly made and covered with uruku—around his neck, as well as two necklaces of coati teeth. He was then scarified on the legs by Iši, his father's brother. Meanwhile, the two infants were given their first haircut by the mother. During this operation they howled continually. After being scarified, the father's legs were washed and smeared with uruku. He then returned to his hammock and began to eat maize. I asked him what he could eat and what he could not eat at this time, and he gave me the following

list of foods, which he said applied to the women as well:

Foods not taboo

Peccary.
Tapir.
Duck.
Turtle.
Cormorant.
Spider monkey.
Capuchin monkey.
Deer.
Macaw.
Fish.
Curassow.
Squirrel.
Agouti.
Alligator.
All vegetable foods.
All fruits except papaya.

Taboo foods

Coati.
Anteater.
Harpy eagle.
Howler monkey.
Guan.
Toucan.
Paca.
Parrot.
Jaguar.
Porcupine.
Papaya.

When the mother finished giving the infants a haircut, the depilated hair was wrapped into two separate cotton balls and hung around the necks of the two women. The mother now gave the boy infant to her husband to hold while she went out to defecate. When she returned, he removed the baby slings and the coati necklaces and put them around her neck. He was then given a haircut by his sister, the hair clippings being thrown in the hole with the afterbirth. Feather ornaments were then put in his hair, in the traditional fashion by his sister. After he had been decorated, he scarified the legs of the mother and of Araia, who was taking care of the female infant. Both of the women had previously bathed. They were then given a haircut, and feather ornaments were glued into their hair. Cotton string covered with uruku was also wound around their arms, legs, and necks. By the time these decorations were complete, the day had almost ended, and after an evening meal of maize all retired to their hammocks.

Early the next morning, January 20, the members of the family smeared uruku on their faces, arms, and legs. The father took off his old wrist guard and put on a new one. Both of the women and the father hung necklaces made of the base of

the quill feathers of the hawk around their necks. The women were also wearing necklaces containing the depilated hair of the infants. Several small, loosely woven baskets were made by the mother, and these were filled with ashes.

At 8 a. m. the party left for the bush on a trail leading out from the east side of the house. The father of the twins and his two wives were accompanied by one of his nephews, who led the party with a basket of ashes which he strewed along the trail. The two women followed behind and also scattered ashes. The mother likewise carried a calabash of water, but she did not sprinkle this along the way. The father brought up the rear of the party, carrying nothing but his bow and two arrows. Not a word was said as the party proceeded along the way.

After walking about 10 minutes, when there were no more ashes left in the baskets, the party made a halt. The mother sat down and placed the two children in her lap. The father left, shortly returning with a green leaf of the motacú palm from which the mother then began to weave a carrying basket. The father and his nephew went off in quest of firewood, soon returning. The firewood was put in the basket, which was placed on the father's back, and the party set out for the house. Just before arriving, however, a small stick was stuck into the ground, and the empty baskets, which had contained the ashes, were hung on it. The party then returned to the hut. Here a new fire was kindled, and the mother gave the twins a bath from the calabash of water which she had been carrying. The father shortly left the house again and brought back a ripe leaf of the motacú palm, from which the mother wove a basket. When this was completed, she placed in it all the remains from the birth which had been lying in the hole in the ground at the head of the hammock, leaving the basket standing under the hammock. She then went about her regular household duties, and the father went out on the hunt. The period of *couvade* was officially over.

The feather ornaments which are glued into the hair after the birth of a child are worn for about a month afterward. In the case of the above-mentioned twins, the feathers were not cut out of the parents' hair until February 24. The after-birth, moreover, was left standing in the basket underneath the hammock for 16 days before it was

taken by the mother deep into the bush and thrown away.

PATERNITY

Only in one birth which I observed was there any question of the paternity involved or a reluctance on the part of a woman's husband to accept her child as his. Of course, considering the sexual freedom allowed by the Siriono, the true paternity of a child would be difficult to determine, but, as far as the group is concerned, it is only the social role of the father that is important. In the case referred to, one of the wives of Eóko (Tall-one) came into labor early one morning. Eóko left for the hunt before the infant was born but knew that his wife was in labor. She gave birth to a girl about 8 a. m. I was present at the birth and spent the day observing postnatal events, and, like the mother, waiting for Eóko to return and to cut the cord. We waited patiently until about 5 p. m., but Eóko had not yet returned. As a somewhat partial observer at this stage, I became concerned that the infant might die from an infection of the cord and placenta, which had been exposed to the flies the entire day, but upon making the suggestion that the cord should be cut, I was told by the mother and other informants that it was necessary to await the arrival of Eóko. Finally he returned, in company with other hunters, just as the sun was going down. He had shot a few *keN* (capuchin monkeys) which he threw down by the hammock of his first wife, paying no attention, however, to the mother and the newborn infant. In fact, he cast not so much as a glance in their direction.

Meanwhile, the mother took out a piece of bamboo and sat patiently on the ground waiting for Eóko to cut the cord. Instead of so doing, he lay down in his hammock and ordered his first wife to extract the thorns from his hands and feet. This operation took approximately half an hour, by which time it was fairly obvious to all present that Eóko had no intention of cutting the cord. Women began to gather. Seáíi, who was Eóko's niece, came up to me and said softly: "You speak to Eóko; tell him to cut the cord." I replied: "No, you speak to him." She was afraid to do so. Then one of Eóko's relatives remarked that Eóko claimed the child was not his, that he had "divorced" this woman some time before. Following this declaration, one of the mother's female relatives came forward and publicly demanded that

Eóko cut the cord. He paid no attention whatsoever to her but continued to lie in his hammock and smoke his pipe. The mother of the infant took no part in the proceedings but continued to sit quietly on the ground with the child. Darkness set in. The mother's female relatives continued to put pressure on Eóko to cut the cord. Finally, after about an hour, he got up from his hammock, called for a calabash of water, and took a hasty bath. He then stooped down, took the bamboo knife from the mother, and severed the cord, thereby recognizing the child as his. Before doing so, however, he emphatically stated that the child was not his and that he was only cutting the cord to prevent the death of the child.

Eóko's reluctance to accept the infant as his was clearly reflected in his behavior during the period of couvade. He acted as if he did not care whether the infant lived or died. He paid no attention whatsoever to the mother, and although he was decorated with feathers like every father of a newborn child, he underwent few of the other observances designed to protect and insure the life and health of the infant. He was not scarified on the legs, for instance, nor did he observe the rules of staying close to the house. He paid no attention to the food taboos and took no part in the rites terminating the couvade. He repeatedly told me that he had "divorced" this woman and that he would have nothing more to do with her. This was borne out by subsequent events.

NAMING

The Indians' kinship with the animal world is clearly reflected in the system of naming. At birth almost everyone receives an animal name. The most common method of securing such a name is for the father to go in quest of an animal as soon as the prospective mother begins to feel the pangs of childbirth. He usually goes in search of a particular animal, a valiant one like a tapir, a jaguar, or a peccary, but if such an animal is not to be found, the child is named for the first animal that the father kills. It so happens that in the cases of childbirth which I witnessed the father never came home empty-handed from such a hunt.

A specific case will best explain the method of naming. A certain woman at Tibaera called Eantázi (Mother-of-Strong-one) felt birth pangs in the early morning of August 28, 1941. Her

husband, Eantádu (Father-of-Strong-one), upon being informed that the infant was soon expected, picked up his bow and arrows and left immediately for the hunt. Before leaving, however, he told me that he was going to look for a *yákwa* (jaguar) after which to name the baby. The infant was born about 10 a. m. while the father was still out on the hunt. He returned about 5 p. m., carrying a young jaguar on his back. After he had cut the cord, I asked him what the name of the child would be, and he replied, "Yákwa," which was the first animal that he had hunted that day.

The above-mentioned method of naming is practiced when the birth takes place during the day. If a child is born at night, when it is impossible for the father to go hunting, other methods are followed. In such cases, the infant may be named after some unusual characteristic that it possesses, such as a clubfoot, or after an animal some characteristic of which it shows a remarkable resemblance to. In the case of the twins whose birth was described above and which took place at night, the female was called Eáta (Many) because more than one child was born; the boy, Eičá (Twisted) because one of his feet was markedly turned inward. In another instance which I observed, an infant was born about 3 o'clock in the morning. Upon arriving belatedly on the scene, I asked the father what the name of the child would be, and he replied, "Yikína" (Owl monkey). When I questioned him as to why this name was given to the infant, he replied that while the birth was taking place a troop of owl monkeys passed by the house and were heard chattering.

Although there are no formal ceremonies of naming, an infant is usually given a name by one of these methods. At Casarabe, however, where the Indians were living under conditions of forced labor and acculturation, the custom of seeking a name for the infant before it was actually born was supplanted by one in which it was named after the period of couvade was over.

Besides the name that one receives at birth and the various names that one acquires by virtue of having borne children, i. e., through teknonymy, the Siriono are extremely fond of bestowing nicknames on people. These are applied to individuals because of some striking physical characteristic that they possess or because of some outstanding event that happened to them. A man who

falls from a tree, for example, may be known henceforth as "Falling-from-a-tree."

Nicknames change frequently. Some of the common ones coined at Tibaera were the following: Erúba-erási (Sick-face), IkáNge (Bones), Konómbi-ačikwa (Tortoise-rump), Eresaia (Blind), Mbe-erási (Snake-sick), Eidúa-ekwásu (Big-navel), Aífti (Close-at-hand), Etómi (Lazy), EréN-ekída (Fat-vulva), and Mbíku (literally "opossum," but applied to a man who steals other men's women). While I was at Tibaera, the custom of nicknaming also extended to me. One of my nicknames which persisted for some time was Kíkwandúsu (Big-deer), because I was known to be skillful at shooting deer on the pampa. I was also variously called Erésa-erasi (Sick-eyes), Eabóko (Long-hair), and Embúta (Beard). By those Siriono who have had contact with the outside a stranger is invariably called *taita*, the Quechua term for father, old man, or *patrón*.

No sex distinctions are made in the naming of children, and such things as status differences in names, individual names, and taboo names do not exist. Within the band various people may have the same name. At Tibaera, for instance, there were several people by the name of Scáči (Coati), Embúta (Beard), and Eičá (Clubfoot).

INFANCY

When the period of *couvade* is over, the infant, who is then regarded as a definite member of the nuclear and extended family, stays almost constantly with his mother until he is about a year old. Most of the duties pertaining to his care fall to her. Whenever the mother is in the house, the infant lies across her lap; whenever she leaves the house, he is placed in the baby sling and carried astride her hip. He is freely offered the breast whenever he is awake, and if he cries, his mother tries her best to pacify him by this method. She grooms him frequently, watching for the appearance of wood ticks, lice, and skin worms; she carefully protects him from the bites of mosquitoes and other harassing insects which cause him no end of discomfort and distress.

During this early period, infants are carefully watched that they do not play with their feces. The Siriono appear to have made the connection between contact with feces and such ailments as hookworm and dysentery. Consequently, whenever the infant defecates, the excreta are immedi-

ately cleaned up by the mother (she generally uses a hard shell of motacú fruit for this purpose), wrapped in a leaf, and stored in a special depository basket. When this basket becomes full, the mother carries it some distance into the forest and empties the contents where the child can have no contact with them.

In spite of the care with which mothers watch their young babies, I frequently observed infants playing with their feces. On one occasion Ačíba-eóko and his family were busily engaged consuming a batch of manioc. His first wife's baby, a boy about 6 months of age, was lying on the ground near the hammock. The baby defecated while the mother was eating, and she did not see him. After lying in the excreta for several minutes, he began to smear them over himself and shortly thereafter he put some of them into his mouth. At this moment the mother observed what he was doing. She grabbed the infant by the arm, put her finger into his mouth, and cleaned out the excreta, saying at the same time, "*abačikwaia ikwa nde*" ("You are an evil spirit"). Although the baby was badly soiled, he was not bathed, but was wiped with a large leaf. The mother continued to eat without washing her hands.

An infant receives no punishment if he urinates or defecates on his parents. Almost no effort is made by the mother to train an infant in the habits of cleanliness until he can walk, and then they are instilled very gradually. Children who are able to walk, however, soon learn by imitation, and with the assistance of their parents, not to defecate near the hammock. When they are old enough to indicate their needs, the mother gradually leads them farther and farther away from the hammock to urinate and defecate, so that by the time they have reached the age of 3 they have learned not to pollute the house. Until the age of 4 or 5, however, children are still wiped by the mother, who also cleans up the excreta and throws them away. Not until a child has reached the age of 6 does he take care of his defecation needs alone.

Little training is given a child in the matter of urination. Contact with urine is not regarded as harmful, and I frequently observed mothers who did not even move when babies on their laps urinated. Since no clothes are worn by either the mother or the child, the urine soon dries or can readily be washed off. Grown children frequently urinate in the house without censure, and even

adults seldom go more than 10 feet from the house to urinate.

Infants are usually bathed at least once a day. If the band is on the march, infants often receive shower baths from the frequent rains that fall. If the band is settled, the mother usually repairs to the water hole or stream in the late afternoon to bathe both herself and the baby. If not, she usually bathes the baby in the house from a calabash of water. In washing the infant's hands, which she may do more frequently, the mother fills her mouth with water and squirts it on the baby's hands, rubbing them briskly at the same time.

Until a baby is about 6 months of age, he gets no other nourishment than mother's milk. Soon after, however, he may be given a bone to suck on, and his mother begins to supplement his diet with a certain amount of premasticated food. As the infant grows older, he is given more and more premasticated food, so that by the time he is 1 year of age, about 25 percent of his diet consists of foods other than mother's milk. During this time, however, he is never denied the breast if he wants it. In fact, children are rarely, if ever, fully weaned until they are at least 3 years of age, and occasionally one sees a child of 4 or 5 sucking from his mother's breast.

Weaning, like toilet training, is a very gradual process. The rapidity with which it occurs depends largely on how soon another child is expected in the family. If the mother soon becomes pregnant, the infant is discouraged from sucking; if no child is expected, the process may be lengthened considerably. In weaning, the mother usually applies beeswax to her breasts, so that the child receives no reward for his sucking. This method is also employed when the mother is ill and does not want her child to suck. Foul-tasting substances, such as excrement, are never smeared on the breasts to discourage a child from nursing.

Because of the limited time which I spent with the Siriono, I am unable to supply accurate information concerning the age at which such habit patterns as creeping, standing, walking, and talking first appear in children. In all of these respects, however, Siriono infants seem to fall within the normal human range. Parents do little to hasten the maturation process. As habits begin to form, of course, an infant is encouraged to develop them for himself, but if it represents any

strain for him to creep, to stand, or to walk, little attempt is made to force him. If, for instance, an infant is lying on the floor near his mother's hammock and wishes to come to her, he is encouraged to do so by creeping or, if old enough, by walking, but if he starts to cry, which is recognized as a sign that it is too difficult for him, the mother gets up from her hammock and picks him up.

One of the most painful and frustrating experiences that every infant must regularly undergo is that of having his eyebrows and the hair from his forehead depilated. A newborn baby receives his first haircut the day after birth and is subjected to periodic depilations about every 2 weeks thereafter. These are not endured without avoidance and pain. Mothers almost always have to hold infants very forcibly while giving them a haircut, and it is only after a child has reached the age of about 3 years that he resigns himself to this operation without whimpering. Whenever I heard infants howling terrifically, I could be sure they were receiving their semimonthly grooming.

The Siriono are proud parents. They spend a great deal of time in fondling and playing with their children and are delighted to display them to anyone foreign to their camp. I found that one of the best ways to gain the confidence of the Indians was by taking an interest in their children: in bringing them presents, in playing with them, and in curing them of such ailments as hookworm. Their interest in children was also clearly reflected in their conversations with me, for I was bombarded with questions as to how many children I had, where they were living, etc. In order to avoid some explanation of my bachelorhood, which they would not have understood or which would have seemed ridiculous to them, I always told them that I had a wife and several children (I even supplied the names) waiting for me at home, and that as soon as I had obtained the information which my "father" had sent me to gather, I was going to return to my family.

Males are definitely preferred. A pregnant woman always expresses a desire to give birth to a boy. The preference for males, however, is not much reflected in the amount of love or care given an infant. Parents spend as much time fondling a girl as a boy. Even clubfooted children and other deformed infants are shown no lack of partiality in this respect.

CHILDHOOD

The transition from infancy to childhood in Siriono society is a very gradual one. Not only are there no sharp breaks in the process of growing up, but from the time one is a child until one assumes the role of an adult, life is relatively care-free and undisciplined. In fact, this pattern of freedom so carries on throughout adult life that it can be truly said of the Siriono that they are a highly undisciplined people.

In contrast to many primitive societies, where a maternal or paternal relative often assumes the responsibility of formally educating the child, the system of education among the Siriono may best be characterized as informal, random, and haphazard. If there is a general theory of education, it can hardly be more than the necessary one of gradually teaching the child to be as independent as possible of his family, so that by the time he has reached the age of maturity he will be able to shift for himself. Since the amount of knowledge that a child has to absorb to survive in this culturally backward society is small in comparison with what he would have to learn in many other societies, the period of childhood offers more than ample time to instill the patterns of adult behavior without a great deal of formal education.

Until a child can walk or talk, at about the age of 3, he is taught almost everything he knows by his parents and his older siblings, and during the early phases of the education of the child, of course, it is the mother who plays the predominant role. Not only does she feed and care for the child, but she is largely responsible, since the father is way a great deal on the hunt, for teaching him to walk, to talk, and to observe the rules of cleanliness. Young children are, therefore, usually "mothers' boys" or "mothers' girls."

In instilling the habits of prescribed behavior in a child, the principles of reward and punishment are clearly recognized. A mother who is teaching her child to walk, for instance, frequently rewards him, after he has reached his destination, with a bit of wild bee honey or some other tidbit. But if he is violating some taboo, such as eating dirt or a forbidden animal, not only are the rewards withdrawn, but the child may be roughly picked up and set aside to cry by himself for a while. A disobedient child may also be warned that if

he repeats a forbidden act he will be bitten by a snake or carried off by an evil spirit. An unruly child is never beaten, however. At worst, his mother gives him a rough pull or throws some small object at him.

During all of my residence among the Siriono, I observed only one extreme outburst of aggression on the part of a mother against her child. This took place one evening about dusk. Erakúi, a nickname meaning "Pointed-one," had just begun to eat a chunk of broiled peccary meat which she had received from one of her relatives. Her young son, Erámi ("Old-buck"—so-called because he looked like an old man), although he had just eaten, began to complain that he had not had enough to eat. Erakúi paid little attention to him at first, but as he continued to complain, she made a few sharp remarks and finally said to him: "You have already had enough to eat." He replied: "You lie," and made a gesture of grabbing for the meat that she was eating. Suddenly she lost her temper, picked up a spindle lying nearby, and gave the boy a sharp rap on the shoulders. He began to howl and made a dash for the other end of the house to avoid more blows. She followed him a short distance, threw the spindle at him, and then returned to her hammock, where she, too, began to cry. (Mothers almost always cry after they have expressed aggression against their children.) The boy continued to wait at the other end of the house for about 20 minutes after which, since it was getting very dark, he sneaked back and climbed in a hammock with his father. In the morning all had been forgotten.

Children are generally allowed great license in expressing aggression against their parents, who are both patient and long-suffering with them. A young child in a temper tantrum may ordinarily beat his father and his mother as hard as he can, and they will just laugh. When children are neglected or teased by their parents, they often pick up a spindle or stick and strike them with considerable force without being punished. I have even heard fathers encouraging their young sons to strike their mothers. Eantánu told me that such expressions of anger in a child were a sign that he would grow up to be a valiant adult.

Food habits are among the first patterns of behavior that every young child must learn. After weaning, taboo foods are simply withheld from a child, but as he grows older and more omnivorous,

he is threatened with disease and abandonment if he partakes of forbidden foods to which he may be exposed while his parents are not around. The list of foods taboo to him, however, is not long. Among the animals he must never eat is the harpy eagle. This taboo is easy to obey, since this bird is rarely bagged; only two were shot during my residence at Tibaera. The harpy eagle is regarded as the king of the birds by the Siriono, and the eating of its flesh is believed to cause illness (it is never stated what kind) to anyone but an old person. Likewise taboo until one is aged are the anteater, lest one sire or give birth to clubfooted children, and the howler monkey, because it is an "old" animal with a beard and therefore dangerous to eat when one is young. Children are also forbidden the meat of the owl monkey, lest they spend sleepless nights and be restless, and the coati, lest they break out with sores on their bodies. Embryos and the young offspring of animals also cannot be eaten by children, lest they have miscarriages in adulthood.

There are few instances when the above-mentioned food taboos cause a child to suffer from lack of meat. Sometimes, however, hunters return with nothing but a howler monkey or an anteater, and the child is denied a share. On such occasions parents attempt by exchange to secure some edible meat for the child, but in some instances he may be forced to go meat hungry for a day or two. As a last resort, parents sometimes neglect the food taboos in order to satisfy a hungry and whimpering child. I have observed a father offer his crying son anteater meat, for instance, even though it was strictly taboo for the child to eat it. Generally speaking, however, taboo foods are withheld from children, who themselves learn what foods not to eat by the time they have reached the age of 6.

When a child is able to walk and talk, his relations outside of the family begin to broaden. By this time, of course, his education is well underway. Having traveled extensively through jungle and swamp he has already become acquainted with the plants and animals. He knows which ones are good to eat and which ones must be avoided. He has felt the prick of spines. He has experienced the sting of mosquitoes, of scorpions, and of ants. He has seen where animals live and how they are shot. He has watched them being cleaned, gutted, quartered, cooked, and eaten.

He has gone hungry, and he has eaten to excess. He has been sick with malaria, hookworm, and dysentery. He has watched children be born and die. He has seen the aged and sick abandoned. He has observed his parents get drunk, dance, and fight. He has heard of evil spirits, and has been admonished not to venture out of the house at night lest he be carried off by one. In short, although only 3 or 4 years of age, he has already experienced a major part of his natural environment and participated deeply into his culture.

At about the age of 3, although still largely dependent upon his parents, the child begins to stray from the family fire—to play with other children, and to learn those habits which gradually increase his self-reliance and lessen his dependency on the family. His first contacts with people of his own age are generally those with his half brothers, half sisters, and his cousins, who are not only closely related to him genealogically but spatially as well, since the extended family tends to cluster together in the house. A child's first play group, in fact, seldom contains members outside of his extended family. As he grows older, children of the same sex and age from other extended families join the play group, so that at puberty there is usually not more than one play group for each sex in the entire band. Since the local group is small, play groups seldom contain over five or six members.

Since the aim to which every Siriono male aspires is to be an excellent hunter, young boys get an early education, through play, in the art of the chase. Before a boy is 3 months of age his father has made him a miniature bow and arrows which, although he will not be able to use them for several years, are symbolic of his adult role as a hunter. By the time a boy is 3 years of age he is already pulling on some kind of a bow, and with his companions he spends many pleasant hours shooting his weapons at any nonhuman target that strikes his fancy. As he grows older and more skillful with his bow, he begins to select living targets, such as butterflies and insects, and when his marksmanship is perfected he is encouraged to stalk woodpeckers and other birds that light on branches near the house. Consequently, by the time a boy is 8 he has usually bagged some game animal, although only a small bird.

Like young boys, girls, too, through play, get

an early exposure to some of the household tasks which they have to perform when they are adults. As the bow symbolizes the hunting role of the boy, so the spindle symbolizes the spinning role of the girl. Before a girl is 3 years of age her father has made her a miniature spindle with which she practices the art of spinning as she matures.

Strikingly enough, miniature bows and arrows for boys and spindles for girls are the only toys which the Siriono make for their children. There is a conspicuous lack of dolls, animal figures, puzzles, cradles, stilts, balls, string figures, etc., so commonly found in other primitive societies. Occasionally a baby tortoise or the young of some animal is brought in from the forest for a child to play with, but such pets are usually treated so roughly that they die within a few days' time. Moreover, such common amusements for children as games of tag, of hide-and-seek, and racing are unknown in Siriono society. Organized games and contests for children (except wrestling for boys) seem to be entirely lacking.

Besides playing with their bows and arrows, boys amuse themselves in other ways: climbing trees, playing in the water, fishing, learning to swim, chasing one another around camp, and wrestling. They also spend a great deal of time lying in their hammocks, a custom they seem readily to learn from their parents.

Girls play especially at home: making baskets and pots, spinning cotton thread, and twining bark-fiber string. They also frequently assist their mothers in performing such simple household tasks as shelling maize, roasting wild fruits, and carrying water. Young girls also spend a great deal of time grooming each other, depilating the hair from their foreheads and picking out and eating the lice from their heads. In general, by the time they have reached the age of 8, girls have learned to weave baskets, to twine bark-fiber string, to spin cotton thread, and to perform most of the tasks which the society assigns to the adult female.

Within play groups aggression is freely expressed. When boys are playing with their bows and arrows (boys' arrows always have blunt ends, and their bows shoot with little force), accidents sometimes occur, and occasionally one child shoots another intentionally, even though boys are admonished not to point their weapons at any human target. When such accidents or

shootings occur (children are seldom wounded as a result of them), a fight usually breaks out, and the child who has been hit often strikes back at the boy who shot him. Adults generally take no part in these fights (they usually laugh at them), but the loser almost always runs crying to his parents for protection.

Considerable teasing and torturing—such things as pinching of the genitals, poking fingers in the eyes, and scratching—of young children by older children take place. A young child most often protects himself from such attacks with a brand of fire or a digging stick, and if he catches off guard the older child who molested him, he may burn him rather severely or give him a sharp rap on the head. Under such circumstances, older children are not allowed to express counter aggression.

Sibling rivalry does not seem to be intense. If a quarrel breaks out between siblings, parents almost always take the part of the younger child. There seems, in fact, to be a clear recognition by the Siriono that the younger a child the less responsible he is for his acts. As between sisters and brothers, there seems to be a slight preference in the treatment of boys, though this is scarcely noticeable until puberty. Generally speaking, however, boys receive more food and less discipline than girls.

At about the age of 8, a boy begins to accompany his father on the hunt. This is really the beginning of his serious education as a hunter. Until this time most of his hunting has been confined to the immediate environs of the hut. When a boy first starts to accompany his father, he makes only about one excursion per week, but as he gradually becomes hardened to the jungle, his trips away from camp become more frequent and of longer duration. On these expeditions the boy gradually learns when, where, and how to track and stalk game. His father allows him to take easy shots, so as to reinforce his interest in hunting. The boy is given light loads of game to carry in from the jungle, and if he kills an animal of any importance, such as a peccary or coati, he is decorated with feathers like a mature hunter. During all this time, of course, he is also learning to make bows and arrows and to repair those which have been broken on the hunt. Hence, by the time a boy has reached the age of 12, he is already a full-fledged hunter and is able to sup-

ply a household of his own with game. At this age, girls, too, are ready for the responsibilities of adulthood.

PUBERTY RITES

There are no puberty ceremonies for boys. Girls, however, are required to undergo certain rites before they are eligible for intercourse or marriage. Sexual intercourse with a girl who has not undergone these rites is strictly taboo and is believed to be followed automatically by a supernatural sanction of sickness and death.

Unfortunately I never had an opportunity to witness the puberty ceremonies for girls, but after I had been wandering with the band of Ačiba-eóko in September and October, 1941, I was told upon returning to Tibaera that a number of young girls from the band of Eantádu were then in the forest undergoing these rites. I asked Eantádu to take me to where the ceremonies were being held, but he showed a great reluctance to do so, or even to suggest someone who might accompany me. He said that the rites were taboo and, besides, that he did not know where they were being held. I finally persuaded him, however, to suggest another Indian who agreed to accompany me. We set out in quest of the ceremonial party, but after walking about half a day, we met the participants returning.

From what information I could gather from informants—members of the party and the girls themselves—it seems that all young girls are subjected to these rites shortly before they are married. Menstruation is not a prerequisite for undergoing the ceremonies. Just what the prerequisites are I was never able to determine, beyond the fact that the girls must be of about puberty age. The ceremonies do not take place at any particular times or places. They are held whenever there are a few girls whose parents decide that they are of about the right age to be married.

The ceremonies are held near a water hole or stream about a day's journey from the house. Before proceeding to this site, the girls' heads are completely shaved with a bamboo knife. They are accompanied into the forest by their parents, and usually by a few old men and women who are members of the extended family. Some hunters may go along to supply the party with game. Upon arriving at the water hole or stream,

the men construct a raised platform of poles on which the girls are required to sit during the ceremonies, which last for about 2 or 3 days. During this time they are subjected to repeated baths to purify them for intercourse and marriage. They are also told what foods they can and cannot eat during the period following the rites and before marriage. Adult members of the party sing and dance a great deal during the ceremonies. After about 2 or 3 days of such activity, the party returns to the house.

Following these rites in the forest, the girls are not immediately available for intercourse and marriage. They must wait until their hair has again grown to the length of their chins, which takes about a year. During this time they are subjected to the following food taboos. They cannot eat guan, macaw, monkey, curassow, toucan, anteater, coati, harpy eagle, parrot, paca, armadillo, opossum, porcupine, fox, and eggs of any kind. The reasons for not allowing them to eat these foods were never made clear to me except in the case of eggs, which are believed to cause multiple births, and porcupine and anteater, which are believed to cause the birth of clubfooted children. The following foods, however, are not taboo: all vegetable foods, fruits, fish, tortoise, peccary, tapir, deer, agouti, duck, alligator, cormorant, otter, and squirrel.

In addition to being subject to food taboos, adolescent girls, after they have undergone the ceremonies that take place in the forest but before they are eligible for marriage, must do considerable work for the first time in their lives. In many instances they have already been betrothed to potential husbands and therefore spend considerable time preparing themselves for marriage: carrying firewood, twining string, spinning thread, grinding maize, weaving baskets, making pots, and collecting food.

After the rites of puberty have been completed, a girl is no longer regarded as *yukwáki* (a girl), but is free to have intercourse with her potential husbands and to be married to one of them. In this connection it is interesting to note that there were a number of girls at Tibaera already married or having intercourse who had not yet menstruated. Ngidá (Bow), a boy, for example, was married to Yikína (Owl-monkey) while I was living at Tibaera. She was about 10 years of age and showed no signs of maturity at this time.

Some 2 years later I made a plane flight to Lago Huachi on which some Siriono were camped, among them Ngidá and Yikína. The latter was just beginning to show signs of adolescence after more than 2 years of marriage. In another instance, Kimbai-ñéti (Little-man), a mature man whose wife had died, married Edabóbo (Armpit), a girl who had not yet reached adolescence. They lived together for some months while I was at Tibaera.

MARRIAGE

The preferred form of marriage is that between a man and his mother's brother's daughter. Marriage between a man and his father's sister's daughter is forbidden. Preferential mating is thus of the asymmetrical cross-cousin type. In actual practice, however, the choice of a mate is not limited to a first cross-cousin. If such a relative is not available for marriage, a second cross-cousin, a first cross-cousin once removed, a classificatory cross-cousin, or a nonrelative may be substituted.

Of the 14 marriages which I analyzed in one of the bands, 6 were between a man and his mother's brother's daughter. The rest were either between second cross-cousins, first cross-cousins once removed, classificatory cross-cousins, or nonrelatives. Although marriage between a man and his father's sister's daughter is forbidden, I did, however, find one instance of a secondary marriage between a man and his father's sister's daughter's daughter, i. e., his first cross-cousin once removed through his father's sister. But marriages of this kind are exceptional (secondary, etc.) rather than the rule, as attested by the fact that almost 50 percent of them were between a man and his mother's brother's daughter. The preference for the latter type of marriage is also clearly reflected in the kinship system. A man calls his mother's brother's daughter "potential spouse," and a woman calls her father's sister's son "potential spouse," while a man calls his father's sister's daughter by the same term that he calls his father's sister, and a woman calls her mother's brother's son by the same term that she calls her brother's son.

Except for the existence of such upsetting factors as polygyny, divorce, death, sororate, levirate, etc., more marriages between preferred cross-cousins would likely occur. Because of one or

another of these factors, however, there seems to be a tendency on the part of the adult men to marry younger second wives who stand in a classificatory, rather than a real cross-cousin relationship to them. Hence, when a young man reaches marriageable age, he may find that his first cross-cousin has already been taken to wife, and he is forced to marry a classificatory cross-cousin instead of his rightful spouse.

In addition to acquiring a wife by cross-cousin marriage, a man may also obtain a first, second, third, or fourth wife by means of the sororate or the levirate both of which are practiced by the Siriono. Of the four plural marriages in one of the bands, three were between a man and two or more sisters. In the fourth, the man had acquired his second wife through the levirate. There is no set rule, however, that a man who marries a woman must also marry her sisters, or that a man must marry the wife of a brother on the occasion of the latter's death. If a man desires these wives, however, he has first claim upon them, and he usually takes advantage of his rights if the woman is young or otherwise desirable.

Generally speaking, there is a strong tendency for brothers to marry sisters. Hence, the condition which earlier evolutionary writers referred to as group marriage is commonly found among the Siriono.

There are no fixed rules of endogamy or exogamy. Bands are more endogamous than exogamous, however, because they rarely have relations with one another and because eligible mates can usually be found within one's own band. When bands do come in contact with one another, exogamous marriages may occur. Sometimes, too, when there are no available real or classificatory cross-cousins or nonrelatives in the band, a man may go in quest of a wife from another band. But instances of this kind are rare for several reasons. In the first place, to locate another band involves great effort; it may mean as many as 8 or 10 days' journey on foot. In the second place, if a man does run across another band, he has no security of finding a wife there, since the men of that band are likely to hoard their women for themselves. In the third place, even though a man has no real wife in his own band, he may possess a number of potential wives and thus not lack for sexual partners. Finally, because of the rule of matrilineal residence, a man will think

twice before abandoning his relatives for a set of in-laws who may be hostile to him.

The age requirements for marriage are very elastic. Infant betrothal is not practiced, but both boys and girls are often espoused before they have reached the age of maturity. Girls, however, must undergo the puberty ceremonies prior to intercourse and marriage. Boys, on the other hand, undergo no rites or tests of any kind before marriage.

The negotiations for marriage are made between the potential spouses themselves, although the parents-in-law usually know beforehand when the marriage is about to take place. The period of courtship is brief. It consists principally in an indulgence in sexual intercourse on the part of the potential mates and in their arrival at a decision to set up house together. If a girl shows reluctance to marry with her potential spouse, she is chided by her mother for her shortcomings and is thus usually forced into the marriage by ridicule.

The marriage itself takes place without ceremony. This is literally true. No exchanges of property occur. The wedding is not even signified by such a simple act as a feast. The marriage rite consists merely in a notification of the parents-in-law of the decision to marry and of a removal of the man's hammock (residence) from its accustomed place in the house (next to that of his parents) to a position next to that of his wife's parents. Consequently matrilineal residence among the Siriono, when marriage is endogamous, consists of nothing more than a shift of locale within the same house. It is true that newlyweds become the butt of sexual jokes and horseplay for several days, but formal occurrences accompanying the union are completely lacking. In other life crises, such as births and deaths, the immediate participants are at least decorated with feathers, but in the case of marriage even this sign of festivity is lacking.

Although matrilineal residence, in endogamous marriages, does not involve a very great spatial removal of a man from his relatives, it does produce a considerable change in his social obligations. After marriage, a man, instead of hunting for his parents, his sisters, and his unmarried brothers, must hunt for his wife's parents, for her sisters, and for her unmarried brothers. While these obligations are reciprocal, a man

usually supplies more game to his in-laws than he receives in return. A man's relations with his own family, however, are not completely disrupted. Besides being related to his in-laws by blood, he continues to reside in the same house as his family. Moreover, his brother may be married to his wife's sister. If not, his brother is at least a potential husband of his own wife with sex rights over her. Hence, brothers usually maintain close bonds after marriage. They continue to hunt together especially, even though their game may be distributed in different ways.

Only in exogamous marriages are a man's relations with his family completely upset. Because of economic factors, resistance to such marriages sometimes arises. While I was at Tibaera, an exogamous marriage occurred which changed existing conditions considerably. A man named Kimbai-ñéti (Little-man) had been previously married to a woman who died. Since there was no available spouse in the band for him to marry, he was without a wife. He continued to reside, however, with his mother-in-law and her other daughter who was married to another man. Kimbai-ñéti was an excellent hunter and brought a great deal of game into the household. When I arrived from the forest in company with the band of Ačíba-eóko, Kimbai-ñéti located a potential spouse in this band. A marriage was arranged. His former mother-in-law, however, tried her best to break up the match, but without success. Kimbai-ñéti left her house and moved in with his new wife and in-laws. Consequently his former mother-in-law was forced to seek other means of support. Before doing so, however, she tried to convince Kimbai-ñéti and his new wife to violate the rule of matrilineal residence and move back to her house, but they would have none of such a plan.

Polygyny is allowed, and sororal polygyny is preferred. Four of the fourteen marriages in the band of Eantádu were plural marriages, and three of these were sororal unions. Only in one instance was a man married to as many as five wives. Three of these were sisters, while the other two were parallel cousins (classificatory sisters) of these. This man was not a chief but a person of considerable maturity and distinction, being about the best hunter in the band. The chief, however, had three wives, two of whom were sisters, while the third he had

inherited from his younger brother who died. One of the chief's other brothers also had two wives who were sisters. In the other polygynous union, the man had inherited his second wife from his mother's brother who had died and left no other brothers to whom she could pass. On the whole, plural marriages tend to occur among the chiefs and the better hunters, who are people of the highest status.

Divorce is relatively easy and is usually caused by adultery or by too frequent intercourse with potential spouses to the neglect of the real spouse. The men always divorce the women, i. e., they "cast them out" or "throw them away." In instances of this kind, the woman usually immediately marries one of her potential spouses with whom she has been having sex relations. Divorces are not common. Women are an asset as long as they can work and bear children, and more than one wife is a mark of status. Thus, although men frequently threaten to divorce their wives so as to keep them in line, they actually rarely ever do so.

The children of divorced couples always remain with the mother. The father changes his residence back to that of his relatives or to that of his new wife. He continues to supply his children with food, however, at least until the mother remarries. Relations between divorced couples are not particularly strained. No stigma attaches to a divorced woman, and she may even occasionally indulge in sex with her former husband.

ADULTHOOD

Adulthood is the time of life when responsibilities are the greatest and status the highest. Among the Siriono this state is signified by marriage and is attained when children are born. Bachelors and spinsters, of whom there are few, have little position in this society, where survival depends on all types of cooperation between husband and wife.

The Siriono are ushered into adulthood prematurely if not abruptly. Younger than in most societies one must take the role of an adult, for younger than in most societies one grows old and dies. The rigors of life being intense, there is a 50-50 chance at least that one's parents will not be alive when one reaches the childbearing age. Consequently boys and girls are frequently

married before they have undergone the physiological changes that accompany adolescence.

While the obligations of adulthood are not extreme (the needs of the society are minimal), the struggle for survival is intense. There is no security of food; there are long and forced marches through spiny jungle and swamp; there are many sleepless nights of wind, rain, and insect pests; there is constant threat of disease and death. In short, the natural environment is harsh, and the techniques which the culture has developed for dealing with it are crude and insecure. Hence a person must be on the alert most of his waking time to procure the bare necessities of life.

While ceremonial life is almost negligible among the Siriono, membership in full adulthood is signified by participation in a bloodletting ceremony and drinking feast which is called *hidai-idákwa*. This is about the only ceremony performed by the Siriono. It was never held while I was living with them, but the marks on the arms of adult men and women were visible evidence that it is occasionally performed.

Hidai-idákwa, or arm piercing, is never carried out until one is adult and has had children. As Eantádu told me, "When a woman has had a child and a man is father of a child, they are ready for *hidai-idákwa*." The principal reason for holding the ceremony is to get rid of old blood—to rejuvenate one. Eantádu said, "The blood is heavy; it must be 'thrown away'." *Hidai-idákwa* also performs the magical function of increasing the supply of food.

Under strictly aboriginal conditions the ceremony is apparently held once a year, when the trees are flowering and there is an abundance of honey. Men and women collect large quantities of honey, and mead is brewed. While the mead is maturing, people participating in the ceremony have their hair cut, and are decorated with feathers and painted with uruku.

The ceremony begins with a drinking feast. The men hold one; the women another. Children are tended by those too young to take part or by those not participating in the ceremony for other reasons. Singing and dancing are a prominent part of the festival. When the participants reach a drunken stage, they pierce each other in the arms with a dorsal spine of the sting ray, and the blood is let into small holes in the ground. Men usually perform the operation both on themselves

and on the women. Each person is punctured about a half dozen times, the men on the lower arms from the wrist to the elbow and the women on the upper arms from the elbow to the shoulder. On the morning following bloodletting, the men depart for the hunt at the break of day, the women following (with baskets of ashes which they spread along the trail) to gather palm cabbage. They return from the forest about noon, and drinking begins again. By the end of the second day the supply of mead has usually been exhausted, and the celebration ends.

A general feast is not held during the ceremony, but people eat at their own fires. Old pots must be thrown away, and cooking is done in new ones. According to informants, the participants are not allowed to eat the following foods for about 3 days after bloodletting: guan, coati, anteater, jaguar, deer, squirrel, otter, monkey, tortoise, fox, armadillo, paca, porcupine, agouti, and palm cabbage. If they violate these food taboos, it is believed that the wounds caused by bloodletting will become infected. Consequently, the game hunted by the participants is distributed to members of the extended family not taking part in the rites. According to Eóko, the diet of the ceremonial party is limited to peccary, tapir, fish, and vegetable foods (except palm cabbage).

No one is obligated to undergo *hidai-idákwa*, but the scars left on the arms by bloodletting are always pointed to with pride. Every child aspires to such a series of tribal marks, for they are visible evidence of maturity.

Besides being a rejuvenation ceremony and a mark of adulthood, *hidai-idákwa* is also believed to insure the supply of food. Kénda told me that during the ceremony the animals all come near the house to see the men gaily attired with feathers and uruku, and to hear them sing. Therefore, when the men go out to hunt after *hidai-idákwa*, they always encounter game.

The adult Siriono spends about half of his waking time wandering around the forest in search of game and food. About one-third of this is spent alone, one-third with fellow hunters, and one-third on expeditions with his family. On the average hunting day he covers approximately 15 miles. Unless he is accompanied by his wife or fellow hunters, he alone carries in the game that he bags. He spends little time in his gardens except at sowing and harvest. His working day

consists largely in hunting, fishing, and gathering.

The adult female, on the other hand, spends much more of her time in the house. When the band or family is not on the march, she devotes a large part of each day to cooking, eating, attending children, quarreling with her neighbors, spinning cotton thread, twining bark-fiber string, weaving mats or baskets, coiling pots or pipes, repairing hammocks, preparing feather ornaments, carrying water, bringing in firewood, or collecting motacú fruits and palm cabbage, which are found in abundance just outside of every hut. She seldom goes any distance into the forest alone or in company with other women. During the rainy season, however, she frequently makes excursions of a day or two with her husband to collect wild fruits, and during the dry season, she may be more or less continually on the march with the entire extended family in quest of food. Like her husband, she does little agricultural work, this being a relatively unimportant activity.

When not wandering around the forest, the adult male is most frequently found in his hammock: resting, eating, smoking, playing with his children, arguing with his wife, cursing the weather, slapping insects, repairing or making arrows. Apart from these activities, he has little recreation. He has few friends but his immediate relatives; he plays no games; he indulges in no sports except occasional wrestling; he does not gamble; he rarely gets drunk, not more than six or eight times a year; he has no hobbies but sex, which he indulges in whenever the spirit moves him; he belongs to no clubs or associations; he has few magical or religious obligations; he sometimes takes part in singing and dancing with his tribesmen on nights of the full moon, but only rarely (about once a year) joins them in drinking and bloodletting to restore his fading youth. All and all, his activities remain on the same monotonous level day after day and year after year, and they are centered largely around the satisfaction of the basic needs of hunger, sex, and avoidance of fatigue and pain.

The life of a woman is equally harsh, drab, and concerned with basic necessities of life. While a woman's position is little inferior to that of a man, the obligation of bringing her children to maturity leaves little time for rest. She enjoys even less respite from labor than her husband. Her recreation is derived principally from the gossip and

quarreling that occur around the fireside, when she is performing the routine household tasks that must be done each day. While she enjoys about the same privileges as her husband, the perennial presence of young children often prevents her from participation in the recreational activities that do exist.

The period of adulthood among the Siriono can hardly be termed a happy one. At best, an adult can look forward to occasional periods of food satiation, sexual satisfaction, and relief from anxiety and pain—a few years during which to bring his children to maturity so that they may carry on. By the time a person is 30 years of age, his powers begin to wane, and as he approaches 40, he is already in the category of old age. Shortly thereafter, he must make way for his grandchildren and face his declining years in dependence and neglect.

OLD AGE

The aged experience an unpleasant time of it in Siriono society. Since status is determined largely by immediate utility to the group, the inability of the aged to compete with the younger members of the society places them somewhat in the category of excess baggage. Having outlived their usefulness, they are relegated to a position of obscurity. Actually the aged are quite a burden. They eat but are unable to hunt, fish, or collect food; they sometimes hoard a young spouse but are unable to beget children; they move at a snail's pace and hinder the mobility of the group.

Where existence depends upon direct utility, however, longevity is not great. The aged and infirm are weeded out shortly after their decrepitude begins to appear. Consequently, the Siriono band rarely contains many members who belong to generations above the parent or below the child. At Tibaera there were only four grandparent-grandchild relationships, and great-grandparents and great-grandchildren did not exist. Although this is a hazardous guess, the average life span of the Siriono—discounting infant mortality—probably falls somewhere between the ages of 35 and 40.

Besides the inability of the aged to perform as well as younger members of the society, certain physical signs of senescence are also recognized. Women who have passed through the menopause are assigned to the category of anility. Deep wrinkles, heavy beards in men, gray hair (occurs

very rarely), stooped shoulders, and a halting gait are regarded as signs of old age.

When a person becomes too ill or infirm to follow the fortunes of the band, he is abandoned to shift for himself. Since this was the fate of a sick Indian whom I knew, the details of her case will best serve to illustrate the treatment accorded the aged in Siriono society. The case in question occurred while I was wandering with the Indians near Yaguarú, Guarayos. The band decided to make a move in the direction of the Rio Blanco. While they were making preparations for the journey, my attention was called to a middle-aged woman who was lying sick in her hammock, too sick to speak. I inquired of the chief what they planned to do with her. He referred me to her husband who told me that she would be left to die because she was too ill to walk and because she was going to die anyway. Departure was scheduled for the following morning. I was on hand to observe the event. The entire band walked out of the camp without so much as a farewell to the dying woman. Even her husband departed without saying good-by. She was left with fire, a calabash of water, her personal belongings, and nothing more. She was too sick to protest.

After the band had left, I set out in company with a number of Indians for the Mission of Yaguarú to cure myself of an eye ailment. On my return about 3 weeks later, I passed by the same spot again. I went into the house, but found no sign of the woman there. I continued my journey down the trail in the direction of Tibaera and soon came upon a hut in which the band had camped the day I parted from them. Just outside of this shelter were the remains (and hammock) of the sick woman. By this time, of course, the ants and vultures had stripped the bones clean. She had tried her utmost to follow the fortunes of the band, but had failed and had experienced the same fate that is accorded all Siriono whose days of utility are over.

DISEASE AND MEDICINE

The principal ailments of which the Siriono are victims are malaria, dysentery, hookworm, and skin diseases. Among the aboriginal groups still surviving in the forest, venereal diseases and tuberculosis are as yet unknown, but under conditions of contact, these maladies have been

largely responsible for the declining population. Such tropical diseases as leprosy and yaws, although common among the whites, are unknown among the Indians.

Knowledge of disease and medicine is not extensive. While a theory of natural causation is recognized with respect to such minor ailments as wounds, burns, and stomach trouble, the majority of maladies, as well as accidents, are thought to be caused by evil spirits called *abačikwaia*. These spirits enter the mouth or nose when a person is sleeping (especially when he is snoring) and settle in the regions where the pain is felt.

In a confused sense there is also a belief that disease is caused by the absence of soul. A person's soul may leave his body while he is dreaming, and if it does much wandering during the night, he is apt to be tired and ill the following day. Informants frequently told me that they were ill because their souls had been "hunting" or "walking" the night before.

The violation of taboos, too, especially food taboos, may be regarded as one of the principal causes of disease. The conditions following a breach of tribal custom are particularly favorable for the entrance into the body of the innumerable evil spirits which are ever present in nature.

Sorcery and witchcraft seem to be almost negligible as causes of disease. I never heard of a single instance in which individuals were accused of employing such methods to injure fellow tribesmen. I was told, however, that threats of sorcery are not unknown as a means of keeping people in line. If a man has an enemy who has been causing him trouble, for instance, he may say to him, "Watch out, or I will take you with me when I die." But such admonitions are rarely used, however effective they may be as a means of deterring people from harming others.

As sickness not infrequently leads to abandonment and death, the slightest provocation is cause for alarm. When ailments appear, the Indians take to their hammocks and rarely leave them until all symptoms of the disease disappear or until death overcomes them. The conditions for cure, however, are very adverse. The patient lies in his hammock on the side of which a smoky fire is kept burning, thus shutting him out from proper air. Moreover, the house is always dark, and since it offers but the flimsiest protection from the weather, the patient is constantly exposed to

rain and cold. On the psychological side, conditions are even worse. The patient is himself filled with an intense anxiety that he is going to die, and this attitude is reinforced by his relatives, who do little or nothing to change it.

The anxieties accompanying illness are, of course, very realistic among the Siriono, for they have almost no methods of effecting a cure. Shamans and medical practitioners are entirely lacking in this society, so that a patient must depend largely on the fortunes of chance in order to recover. Near relatives (always women), such as a mother or a wife, may sometimes chant over a person who is slightly ill, but if he takes a turn for the worse, he may be neglected and thus gradually die from lack of proper care. If the tribe is on the march, he may even be abandoned with no hope of recovery. Doubtless for this reason such a great fear of sickness exists.

One of the principal signs of illness, apart from the pain that accompanies it, is the loss of appetite. When people cannot eat, they are believed to be very ill. If a person does not eat for several days, it is regarded as a sure sign that he will die. For this reason, patients never diet when they are ill. The anxiety based probably on the drive of hunger is sufficiently strong to enable people to eat when food is definitely detrimental to them. In several such instances which I observed, people actually ate themselves to death.

While I was at Casarabe, Téko became sick with dysenterylike infection of the stomach. His illness coincided with the season of maturity of the wild fruit coquino, which is greatly relished by the Siriono. In view of the nature of his illness, I suggested to Téko that he refrain from eating this fruit for several days because of the acid which it contains, often highly irritating to the stomach when eaten in large quantities. But my words had no effect. His relatives collected huge quantities of coquino during the day and brought Téko large baskets of them every night on their return from the forest. In spite of terrific stomach pains and diarrhea, he managed to eat as many as a hundred of these fruits (each one about the size of a large plum) each night, thus irritating his otherwise painful condition. After several days of such a diet, he finally expired one morning, but not without having eaten a full basket of these fruits the night before. Until his death his prognosis had been good, according to

native theory, because he had been able to eat.

In general the *materia medica* is sparse. Uruku, whose curing properties are believed to be very beneficial, is the panacea for all ills. Its powers are believed not only to drive out the evil spirits that cause disease, but to protect one from them as well. Consequently, in sickness or in health, the Indians are rarely seen without a protective covering of uruku. Whenever I myself was ill, uruku was always the first remedy suggested to me by my Indian friends.

Scarification is widely practiced as a relief from pain. The suffering individual is scratched (by himself or by one of his relatives) with an eye tooth of a rat or squirrel in the area where the pain is felt. A small amount of "old blood" is released by this practice, and the scarified area is covered with uruku. Massage, too, is employed to cure minor ailments. In chest complaints, for instance, the back and chest are vigorously rubbed with the hands and kneaded with the fists. Sucking and squeezing are most generally employed to extract pus from festering wounds.

Herbal remedies are almost unknown, except in the treatment of diarrhea. A diarrhetic child is sometimes treated with a decoction made from the bark of a tree which the Siriono call *hidi-ndimbi*. Strips of the same bark are also wound around the patient's stomach. Green leaves are bound over open wounds and sores, and strips of bark fiber are bound tightly above infections of the arms and legs to prevent their spread.

The Siriono possess no remedies for snake bite and have no knowledge of setting broken bones. Aching teeth are extracted with the fingers after they become loose. Hairy skin worms, of which the Indians are constant victims, are removed in the following manner. A small amount of the sticky substance from the inside of the pipe stem is extracted with a palm straw and placed in the hole where the worm resides. This irritates the worm which pushes out its head for air. It is then grasped by the head and squeezed until it pops out of the skin.

DEATH AND BURIAL

For a Siriono, death is the culmination of an often short and always bitter struggle for survival. Having wrestled valiantly to live, he wrestles equally valiantly not to die. But the odds are all against him. His environment and

culture are harsh. Having no medicine to prolong his life, he is often consigned to an early grave; having no religion to calm his soul, he frequently dies with fear and bitterness in his heart.

A dying individual, unless he is a child, is given little attention. His near relatives, however, generally assemble to watch him breathe his last. The women mourners sit on the ground around him and weep profusely, but the men show few signs of grief. They usually squat around him and silently smoke their pipes. When a great hunter is dying, however, fellow tribesmen sometimes squat around him and ask him to pass them some of his luck. If, for instance, he was a great hunter of tapir in his day, they may ask him, "Grandfather, where can we find tapir?" He usually answers, "After I die go to (such and such a place) when the sun is rising and you will find tapir." On the sunrise following the disposal of the corpse, the men set out for the spot designated and often find a tapir there.

Among the Siriono a person is not allowed to die in his hammock. Death in a hammock pollutes it, and it will have to be thrown away. Therefore, a dying individual is usually removed from his hammock several hours before death and placed on a mat woven from the heart leaves of motacú palm. Once on such a death mat a person seldom recovers. As he more closely approaches his fate, he is poked in the eyes or pinched in the genitals from time to time to note whether he still shows signs of life; his mouth is frequently opened to determine whether he is still breathing. Only when a person ceases to breathe is he regarded as dead. Once he is dead, however, little attention is paid to his corpse until disposal, which must take place before the next sunset.

Aboriginally the Siriono do not bury their dead. The corpse, extended with arms to the side, is wrapped in two mats of motacú palm and placed on a platform in the house. It is not oriented in any special way. With the deceased are placed his calabashes filled with water, his pipes, and fire. No food is left. Once the corpse is disposed of the house is abandoned; but before leaving, the men shoot arrows in all directions through the house to drive out the evil spirits. The band then moves on to a new location—often several days' journey away.

The period of mourning lasts about 3 days. On the day following the disposal of the corpse,

mourners are scarified (by near relatives) on the upper and lower legs with an eye tooth of a rat or squirrel, and they rub their legs and faces with uruku. On the second day, they are decorated with the feathers of the harpy eagle, the curassow, and the toucan. With this protection they may resume normal life on the third day.

Although grief-stricken parents and widows often do not eat for a day or two following the death of a beloved one, there are no food taboos that apply specifically to the period of mourning. Widows usually cry ceremonially about an hour a day for about 3 days during mourning, but apart from this they undergo no more strenuous rites than other relatives of the deceased.

A widow or widower may remarry within a few days after the death of a spouse. In three deaths which I observed, the widows were married by levirate husbands on the third day after the mortuary rites. In two of these the widows passed to the deceased's oldest brother; in the third, to his parallel cousin (classificatory brother).

While living with the Siriono, I never had an opportunity to observe a funeral under strictly aboriginal conditions. However, I was present at a number of deaths at Tibaera where, according to informants, the mortuary rites were essentially the same as those which take place in the forest, except that the corpse was interred and that the house was not abandoned. Some details of these will best serve to illustrate the treatment of the dead in Siriono society.

Erésá-eóko (Long-eyes), a bearded man of about 40 years of age, died in October 1941. About 10 days before his death, he was stricken with sharp pains in his stomach, accompanied by constant diarrhea. He told me that an *abačikwaia* (evil spirit) was responsible for his illness. During the 10 days that he lay sick, he was attended solely by his wife. Although she gave him no medicines of any kind, she stood by his hammock and hummed chants for an hour or so each day to drive out the evil spirits. This treatment being unsuccessful, she took six of Erésá-eóko's arrows and stuck them into the ground near the head of his hammock—also to drive out the evil spirits. But to no avail, for Erésá-eóko got worse and died shortly thereafter.

In the morning of the day of Erésá-eóko's death, his wife wove two mats of motacú palm. Erésá-eóko was lifted from his hammock while

still alive and placed on one of these mats, where he lay groaning most of the morning. He vomited and defecated frequently. The vomit and excreta were cleaned up by his wife, who wrapped them in leaves and placed them in a special basket hanging nearby. She sat watch over him, opening his eyes and mouth, and pinching his testicles, from time to time, until he finally died at about 2 o'clock in the afternoon.

As soon as it was certain that Erésá-eóko was dead, his corpse was covered with a mat of motacú and, within an hour's time, carried by several of his cousins about a quarter of a mile into the forest for interment. The funeral party consisted of five men—all cousins of the deceased—and the widow. Besides the corpse, they carried with them various possessions of the deceased: his drinking vessels full of water, his pipes, fire, and the basket containing his vomit and excreta of the previous 10 days. Upon arriving at the burial site, they dropped the corpse and these possessions to the ground, and a shallow grave was hastily dug with a digging stick by one of the men. This was lined with green boughs of the motacú palm, and the deceased was rolled into it and buried. His calabashes and pipes were placed on top of the grave, and a small fire was built on either side. The vomit and excreta were then thrown away near the grave, and the party returned to the house. Although the widow wept silently during the proceedings, not a word was said by a single member of the funeral party. After returning to the house, the men went to the river and bathed.

On the day after the burial of Erésá-eóko, his widow was scarified on the upper and lower legs by a cowife. Uruku was then applied to her legs and face, and she was decorated with feathers. She ate nothing for 2 days although she smoked her pipe almost continuously. She cried ceremonially for about an hour each morning for 3 days, after which she moved her hammock next to that of one of the wives of Erésá-eánta, her husband's parallel cousin, to whom she passed under the levirate. Other members of the funeral party were also scarified and decorated with feathers.

While I was living at Tibaera, an infant of about 6 months of age died one morning about 11 o'clock. It had been ill for about 3 days with a stomach ailment, caused, according to the mother, by an

evil spirit. After the death the mother began to wail terrifically (the Siriono always express deep grief over the death of a child) and shortly thereafter emptied her breasts on the ground. About an hour later, she scraped up the wet dirt and put it into the basket where the child's excrement was stored.

The child was interred about 4 o'clock the same afternoon. The parents were the only people who went to the grave besides myself. The mother carried the dead infant wrapped in the baby sling which she had been accustomed to transport it in, and it was buried in a shallow grave lined with green boughs of motacú. A fire was made on both sides of the grave before the parents returned to the house. Both fasted for the rest of the day. The following day they were scarified on the legs and decorated with feathers. The father ate on the day following the burial, but the mother continued her fast until the second day, when she resumed normal life, except for occasional periods of wailing. She continued to empty her breasts, however, to prevent them from drying up.

The disposal of the corpse does not end contact with the dead. After the flesh has rotted, relatives of the deceased are obliged to return and bury the bones. If they are not buried, the soul of the deceased may return as an *abačikwaia* (evil spirit) or a *kurúkwa* (monster) and cause illness and death to the surviving members of the family. The skull, however, is not interred. It is either carried back to the house, where it rests in a special basket near (or under) the hammocks of the immediate relatives of the deceased, or it is abandoned at the site where the bones are buried. In every Siriono hut one finds these skulls, which have been saved as protective family heirlooms; and in wandering around the Siriono country, one not infrequently encounters old skulls that have been thrown away.

The skulls of the ancestors are preserved and carried around for a while as a protection from disease and death. They are also sometimes used in curing. No set rule determines whether a skull will be saved or thrown away. There is, however, a tendency to throw away old skulls as new deaths (and consequently new skulls) appear in the family, and there is also a proneness

to save only the skulls of people greatly loved, such as young children, or of important personages in the family, such as great hunters or chiefs. Many mothers whom I knew in Tibaera were carrying around the skulls of infants who had died not long before. They all told me that they were apt to be sick if they did not follow this custom. In one family which I knew, the skull of a chief called Embutándu (Father-of-Bearded-one), had been carried around by one of his daughters for many years. Whenever any member of her family was ill, this skull was employed to effect a cure. On one occasion I walked into the house and found Nyéka, a son-in-law of the deceased Embutándu, "sick in the chest." He told me that he had an *abačikwaia* (evil spirit) in his chest which was causing him great pain. I asked him how he was going to cure his ailment. He picked up the skull of Embutándu, rubbed it across his chest for a few minutes, and then replied, "Tomorrow, I will not be sick."

When skulls are employed in curing, no magical formulas are recited. Moreover, they are given no special treatment and care apart from being kept in a basket of their own. They are not worshiped, for example, and no offerings are made to them. On occasions, however, I have seen them covered with uruku to make them more effective in curing.

With respect to the cult of the dead, I was told by my companion Silva, who had lived for many years among the Indians at Casarabe and Chiquigani, of another custom which he said prevails among the Siriono. He told me that when a man has had a long streak of ill luck in hunting he may repair to the spot where the bones of an ancestor—one who had been a great hunter—are buried and ask him to change his luck and to tell him where to go in quest of game. Upon inquiring of informants as to whether such a custom was practiced, I was answered in the negative by most of them. A few, however, told me that others may have followed such a practice, but that they themselves had never done so. I might add that during all of my residence among the Siriono—and the hunting was frequently bad—I never observed an Indian carry out such a rite.

RELIGION AND MAGIC

RELIGION

Native religion has not reached a high degree of elaboration among the Siriono. One of the reasons for this may be that the Indians are forced to devote most of their time and energy to the immediate struggle for survival. Both shamans and priests are lacking in this unprofessional society, and the confused beliefs and practices that are adhered to with respect to the supernatural world have not been integrated into a complex religious system. As in all societies, however, a distinction between the sacred and profane, the holy and unholy, is clearly drawn by the Siriono. The existence of taboos, of ceremony, of belief in evil spirits, etc., all bear witness to a concern with religious matters.

In this simple society, however, there is no belief in a hierarchy of gods who control the destiny of man. *Yási* (Moon) is the only supernatural being which the Siriono believe in. As has already been mentioned, mythology imparts considerable power to this culture hero who was responsible for the creation of the world and all that is in it, and attesting to the fact that the moon still plays some role in the affairs of men are such beliefs as that the moon causes thunder and lightning by hurling peccaries and jaguars down to earth and that to sleep under the rays of the moon causes blindness. But the moon can scarcely be regarded as a supernatural being in the usual religious sense. It exerts little or no influence on the affairs of men, and no cult has grown up around it.

The core of Siriono religious belief is centered in the fear of animistic spirits. The universe is thought to be peopled with detached evil spirits called *abačikwaia*, which are responsible for most of the misfortunes that befall the human race. Thus cold south winds, accidents, illnesses, bad luck, deaths, etc., are ascribed to the intervention of *abačikwaia*. These spirits are invisible and formless, little can be done to control them, and they are neither worshiped nor propitiated in any way. They can best be avoided by adhering to the traditional customs of the band.

The Siriono also believe in monsters, of whom they have great fear. These are called *kurúkwa*.

Unlike the *abačikwaia*, which are invisible and formless, the *kurúkwa* are visible and somewhat resemble human beings. But they are large, ugly, black, and hairy. These monsters lurk outside of the house at night, where they await their victims, carry them off into the forest, and strangle them. Sometimes the *kurúkwa* even come into the house and snatch people from their hammocks while they are sleeping. During the day, however, there is little danger of the *kurúkwa*. They have great fear of the bow and arrow. Consequently hunters are never assaulted.

Informants told me that the *kurúkwa* are especially fond of waiting outside of the house on nights of drinking feasts. When the men are drunk, they often go outside of the house to urinate or defecate. The *kurúkwa* await them at the edge of the forest and say, "*Man yen ererékwa héri*" ("What is the name of your chief?"). (The *kurúkwa* are especially fond of killing chiefs.) If the men impart the name of the chief to the *kurúkwa*, they will not be harmed; if not, they may be carried off into the forest and strangled.

The *kurúkwa* are believed to have companions like men. When they are unable to find human victims, they hunt tapir, peccary, and other animals. *Kénda*, who was one of my best informants at Casarabe, told me that it was dangerous to let my horse run loose at night because a *kurúkwa* might strangle him.

Many informants identified both *abačikwaia* and *kurúkwa* with ghosts of the dead. Some time after the death of *Téko*, an Indian of Casarabe, *Kénda* told me that he had become a *kurúkwa* and that he had been seen in the forest by other men. At Casarabe one night an old woman was attacked by a *kurúkwa* while asleep in her hammock—just 3 days after the death of her husband. I fired a pistol to drive the *kurúkwa* away, but for several nights thereafter the woman slept with an arrow by her side so as to be able to resist attack. In another instance a widow at Casarabe remarried without undergoing the usual 3-day period of mourning. She was severely criticized by her tribesmen, who thought that her dead husband would return as a *kurúkwa* to wreak vengeance on the group.

MAGIC

Magic, like religion, is little elaborated among the Siriono. Most magical practice that has not already been described has to do in one way or another with increasing and insuring the supply of food. Hunters hang up the skulls of the animals and the feathers of the birds which they bag on sticks near camp or on posts in the house to influence the same animals to return. They smear their faces with uruku and glue feathers into their hair to make them more attractive to game. They also frequently paint the cotton string of their arrows and wrist bands with uruku to give them magical charm. When they kill a harpy eagle, they rub their bodies and hair with the white downy feathers of the breast to absorb some of the power of this mighty bird. They sing and dance not only for recreation but to promote the supply of game as well. All these and many other magical practices already mentioned appear to have as their principal function a reduction of the anxiety that centers around the satisfaction of hunger.

DREAMS

Dreams are thought to be caused by absence and wandering of the soul. Generally they are believed to presage the future. Hunters who dream about hunting a certain animal believe that this is a sign that they will kill one, and after such a dream they often go on a successful chase. One night Eantádu dreamed that he killed a tapir. Early the following morning, he departed for the hunt and returned late in the afternoon having bagged his prize. He told me that he knew he was going to shoot a tapir because he had dreamed about it. Such experiences are common among the Siriono and strongly reinforce the belief that dreams foretell the future.

If dreams are an unconscious expression of desires, then those of the Siriono clearly reflect their preoccupation with the quest for food. While I was only able to record data on some 50 dreams, more than 25 of these are related directly to the eating of food, the hunting of game, and the collecting of edible products from the forest. An especially common type is one in which a person dreams that a relative who is out hunting, has had luck and is returning to camp with game for him. Enía, for example, had a dream that

Eantádu, who was out on the chase, killed a great many peccaries and was returning to camp with broiled peccary meat for him. Another recurring type of dream is one in which a person himself is out hunting, and kills and eats a great deal of game. Kénda reported a dream in which he was hunting fish in a certain lagoon and shooting huge quantities. His brother was with him, and they roasted and ate fish until they could not move. Dreams also reflect strong desires to eat certain kinds of food. Before the ripening of the coquino fruit, which is greatly relished because of its sugar content, Ai-a dreamed that she was in the forest collecting with her husband and that they encountered coquino trees loaded with ripe fruit, which they ate until they were stuffed.

One of the striking things about food dreams is that they seem to occur just about as often when a person is not hungry as when he is hungry. The food dream of Kénda, for example, was reported the morning following a feast in my house the night before. Hence, it would seem, that such dreams reflect considerable concern about food. Indeed, an intense psychological analysis of the dream life of the Siriono—which I have neither the data nor the skill to make—might support the theory that hunger is the most intense motivating force in the society.

THE SOUL

Ideas about the soul among the Siriono are confused and vague. When questioned about such matters, informants displayed a singular apathy for discussing them. Whether such attitudes spring from a lack of ideas, from a fear of the dead, or from some other reason, I was never able to determine. Some Indians said that the soul resides in the head; others, that it resides in the heart; still others, that they did not know.

Prof. Richard Wegner (1934 b, p. 21) has made the claim that the Siriono have a belief in an afterworld called Mbaerunya, to which the souls of good hunters depart after death and where they while away their time drinking maize beer with a Celestial Grandfather who has many wives. Since this statement has already been emphatically denied by Padre Anselm Schermair (1934, p. 520), I need no more than mention here that I, too, found no evidence to corroborate such a belief in

a hereafter. While notions of an afterlife have crept in where the Indians have had contacts with the whites, these are clearly assignable to Christian influence.

Upon inquiring of informants as to the fate of their souls after death, I was almost always given the answer that they did not know. There seemed, however, to be general agreement that the soul of the deceased may become an *abačikwaia* (evil spirit) or a *kurúkwa* (monster), but this form of survival informants were reluctant to contemplate for their own souls. Out of the confusion of ideas (or lack of them) that exist on the subject, it vaguely appears that the soul of a "good" man, i. e., one who has abided by tribal custom and has

the respect of his countrymen, does not return in the form of an evil spirit or monster to harass his surviving relatives, but that that of a "bad" man, i. e., one who breaks tribal taboos and is disliked by his countrymen, may return in one of these forms to cause sickness and death to the living. That the souls of some of the dead can be relied upon to assist the living is clearly indicated by the aforementioned practice of employing the skulls of some ancestors to cure disease. Informants, however, were never able to supply me with any clear-cut ideas as to what happens to the soul of a "good" person after death. One thing seems clear as regards eschatological belief: there is no afterworld to which the soul departs.

SOME PROBLEMS AND CONCLUSIONS⁷

Siriono society presents any number of important anthropological problems, only a few of which can be mentioned here. Having presented in the foregoing sections a few of the descriptive data about the nature of Siriono society, I should like especially to include a few closing remarks, based on the Siriono data, about the problem of hunger frustration and its relation to culture. In this discussion, I propose ultimately to suggest a number of broad generalizations about the relationship between intense hunger frustration and habits and customs that perhaps can and should be tested in other societies where similar conditions exist. It is beyond the scope of this paper to deal with this matter cross-culturally. Before turning to a consideration of this problem, however, it will be necessary to clarify a number of concepts.

Physiologists and psychologists are now agreed that the human organism is stimulated to behave by what are known as drives. These drives are the motivating states of an organism. They are of two kinds: primary (basic or innate) and secondary (derived or acquired). The primary drives are those which result from the normal biological processes and recur at more or less regular intervals, such as hunger, thirst, sex, fatigue, and pain.⁸ These are found in all human

beings. Secondary drives, on the other hand, are learned drives. They are the motivations which result from particular cultural situations. The secondary drives, of course, are based on the primary drives and are supported by the satisfaction of them. But unlike primary drives they are not universally the same. There are doubtless some secondary drives, like prestige and appetites, that are found in all societies; but their intensities and definitions, at least, vary widely from person to person and from society to society. Among the ancient Romans, for example, food preferences were elaborated to a pronounced degree, while among the Siriono there is almost no expression of these secondary drives. Similarly, among the Indians of the northwest Pacific coast the drive for prestige is intense, while among the neighboring Eskimo this drive is but weakly developed.⁹

While it is axiomatic that every society must reinforce or satisfy the basic drives of man in order to survive, up until recent times culture has been little studied from the point of view of the effect of basic drives upon it. We know from the ethnological literature now available that the drives of man are satisfied by almost as wide a variety of techniques as there are societies existing throughout the world. But ethnologists have focused most of their attention on describing the diverse habits and customs that exist in human societies and have laid little stress on the role played by basic drives in shaping them.

⁷ Because of absence from the United States, lack of good library facilities, and exigencies of publication, I have not had an opportunity to examine all of the literature pertaining to subjects here discussed. While my conclusions are based upon data from but one society, I feel that they might be suggestive for work in others. It is for this reason that I am publishing them now, even though incomplete.

⁸ For a list of primary drives, see Murdock, 1945, pp. 127-128

⁹ For an excellent discussion of secondary drives, see Miller and Dollard, 1941, pp. 54-68.

Malinowski¹⁰ was perhaps the first notable modern anthropologist to pay much heed to the impact of basic drives on culture. He founded his functional system on a series of drives which he called the "basic needs of man." In the sociological field a similar point of view was expressed by Sumner and Keller (1927), who founded their sociological system on a number of universal drives. More recently, largely from the stimulus of psychoanalysis and behavioristic psychology, the study of culture from the point of view of drives (primary and secondary) has received notable expression in the works of—to mention a few—Miller and Dollard (1941), Ford (1945), Whiting (1941), Murdock (1945), Mead (1935), Benedict (1934), Linton (1945), Gorer (1938), and DuBois (1944). None of these, or other workers, however, has dealt with a society in which the drive of hunger is so constantly frustrated as to have become the dominant motivating force in shaping habit and custom. Siriono society seems, clearly, to be such a society.

From the data that have already been presented, especially those relating to food, it would seem, indeed, that the most crucial problem with which the Siriono have to deal is that of securing enough to eat, and the fact that they have been much less successful than most societies in solving their economic problems has doubtless elevated hunger to its preeminent role as a motivating force in the society. The reasons for this are numerous and varied: physiological, environmental, and cultural. An analysis of the data suggests that the following are the principal factors that affect the quest for food and that result in the dominant motivating force of hunger.

I. Physiological factors.

A. Hunger drive.

B. Secondary drives based on hunger drive.¹¹

1. Strong secondary drive or appetite for eating.
2. Satisfaction of prestige based primarily on hunger.
3. Sexual appetites to some extent based on hunger.
4. Aggression expressed in terms of food.
5. Anxieties center largely around satisfaction of hunger.

C. Sex drive mobilized principally through hunger.

1. Family founded on economic basis.
2. Extramarital sex partners seduced through rewards of food.

D. Fatigue drive.

1. Long forced marches in quest of food.
2. Tree climbing to harvest fruits, to retrieve game.
3. Running through swamp and jungle in chase of quarry.
4. Burden carrying.

E. Pain drive.

1. Spines and thorns in body.
2. Accidents (falling from trees, etc.).
3. Attacks by animals (jaguars, snakes, alligators, etc.).
4. Suffering from heat, cold, and rain.

II. Environmental factors.

A. Sparse supply of food.

B. Aleatory factors.¹²

1. High probability of nonsuccess in food quest.

C. Climate unfavorable for preservation and storage of food.

III. Cultural factors.

A. Technological insufficiency.

1. Cumbersome weapons.
2. Lack of tools, traps, etc.
3. Sparse development of agriculture.
4. No methods of preserving and storing food.

A more detailed examination of some of these factors will perhaps better explain why it is that hunger becomes such a potent motivating force in Siriono society. In the first place, the supply of food, while sufficient for survival, is seldom abundant. People actually suffer frequently from food deprivation. As well as being sparse, the food supply is highly insecure; chance factors with respect to the food quest here play a much more significant role in affecting culture and behavior than in most other societies. When a hunter sets out in search of game, there is a high probability that his hunt will be unsuccessful or at least only partially rewarding. True, the forest contains some foods, such as palm cabbage and nuts, that are available and abundant the year around and others, such as certain wild fruits, that are relatively plentiful for about 4 months of the year, but these in themselves are not nutritive enough to sustain life for long

¹⁰ See, for example, Malinowski, 1939.

¹¹ These factors, of course, are also cultural.

¹² These factors, like secondary drives, are also cultural.

periods of time. The society, furthermore, is not equipped with cultural techniques for dealing with its environment so as to offer surety of food supply. Agriculture is but little developed; weapons are cumbersome; tools are almost lacking; and food is neither stored nor preserved in any abundance or for any length of time.

Accompanying these frustrating conditions are others adverse to the satisfaction of the hunger drive, especially the fatiguing and painful aspects of the food quest. The hunter and gatherer must go in search of food at least every other day throughout the year. He must walk long distances, as many as 20 miles a day, in his quest for food. He may be forced to run at top speed through almost impenetrable jungle and swamp to bag a single monkey or coati, and once having bagged his prize he may be forced to climb a tree to retrieve it or the arrow with which he shot it. Game and forest products must always be carried back to camp—sometimes a long distance away. In walking and running through swamp and jungle the naked hunter is exposed to thorns, to spines, and to insect pests; he may fall from a tree (as he frequently does) while harvesting fruits or retrieving game; he is exposed to attacks from jaguars, alligators, and poisonous snakes; he sometimes suffers intensely from heat, cold, and rain. At least 25 percent of the time he returns to camp empty-handed or with insufficient food to completely nourish his family, for which he may be chided by his relatives. In short, while the food quest is differentially rewarding because food for survival is always eventually obtained, it is also always punishing because of the fatigue and pain inevitably associated with hunting, fishing, and collecting food.

Psychologically speaking, these are the conditions that give rise to the preoccupation of the Siriono with food problems, to their affective attitudes toward food, and to their strong secondary drives based on the drive of hunger. The anticipation of the intensely punishing aspects of the food quest—actual food deprivation, possible non-success on the hunt, fatigue, pain, and other forms of punishment—tends to evoke strong anticipatory responses with respect to food. These anticipatory responses—for example, strong food responses to weak hunger stimuli—are, in effect, secondary drives. For purposes of this discussion they may be regarded as appetite and anxiety responses.

Actually psychologists are not yet agreed as to the differences between the secondary drives of appetite and anxiety. A satisfactory definition of and a distinction between these two concepts, though potentially of great value in a systematic analysis of culture and human behavior, has yet to be developed. Recently staff members¹³ at the Institute of Human Relations, Yale University, have proposed the following definitions.

Appetite is a secondary drive whose motivating response is anticipatory and whose original response is a parasympathetic response which occurred just prior to or during the goal act of a given drive.

Anxiety is a secondary drive whose motivating response is anticipatory and whose original response is a sympathetic response which occurred just prior to or during the goal act of a given drive.

In the above definitions, the distinction between appetite and anxiety, although both are anticipatory responses, rests on the assumption that in the case of the former the original response arises in the parasympathetic nervous system, while in the case of the latter it arises in the sympathetic nervous system. This is essentially the position taken by Mowrer (1940), who has dealt at some length with the problem of anxiety. It is doubtful, however, whether this distinction is of much practical utility in the analysis of cultural behavior. In the case of the Siriono data the important fact to consider is that there are strong anticipatory responses toward food. Some of these may be purely appetitive responses, others anxiety responses, and still others a combination of both. These anticipatory responses result, moreover, not from a single factor, but from a combination of all the factors listed above.

Attention should be called to the fact that anticipatory responses toward food in Siriono society may be due, in part at least, to the conflicting factors that affect the quest for food. These conflicting factors seem to be much more pronounced among the Siriono than among most other peoples. On the one hand, a man is strongly motivated (and eventually forced, of course) to go in search of food because of a mounting hunger drive, a desire for prestige, or the need for a sexual partner. On the other hand, he is also strongly motivated to lie in his hammock and to postpone the search for food as long as

¹³ These definitions were developed by Dr. I. Child, Dr. John W. M. Whiting, and Dr. Clellan S. Ford. They have not been published as yet.

possible, because of the painful, fatiguing, and otherwise punishing aspects of the food quest. Before a Siriono picks up his bows and arrows to go on a hunt he doubtless asks himself: "Should I or should I not go?" His stomach stimulates him to go; his relatives tell him to go; he may be motivated to leave by a desire to eat tapir, to seduce a potential wife, to acquire or maintain status, or for any number of other reasons. But when he recalls his last or earlier hunt—an occasion when he came back empty-handed after having tramped all day through jungle and swamp, when he was chided by his relatives for his lack of success or skill, and when he returned with his feet full of spines and thorns and his body covered with wood ticks and insect bites—his ardor to leave is likely to be considerably dampened. Under these conditions he is apt to try to get food first by some other means, and if unsuccessful, even to lie down in his hammock for a while until the hunger drive, or the social pressure to go hunting, becomes unbearable. In any case, if there is food around, he is not likely to expose himself to the rigors of the jungle before it is all consumed, for if he departs under these conditions he is certain to find when he returns that the food has already been eaten by someone else. These conflicting factors are doubtless responsible for much of the behavior toward food.¹⁴

The evidence for strong appetitive and anxiety responses toward food in Siriono society is overwhelming. Hasty preparation of food, lack of complex recipes, absence of standardized routines of eating, stealing off into the forest to eat, wolfing food, overeating, reluctance to share food, lack of food preferences except on a quantitative basis, absence of etiquette and ritual with respect to food, eating when sick, eating when not hungry, excessive quarreling over food, fantasies and dreams about food, insults in terms of food, etc., may all be regarded as direct manifestations of the strength of the secondary drive of eating and of the anxiety that centers around the satisfaction of the hunger drive.

How do such attitudes and behavior toward food arise and develop in the Siriono child? A glance at the data from the life cycle clearly indicates that adult behavior toward food cannot be accounted for on the basis of the experiences of in-

fancy and early childhood. The nursing infant is almost never deprived of food; whenever he cries his mother offers him the breast. He is greatly loved. He is exposed to almost no punishment except what he indirectly suffers from the rigors of the environment, but his parents do everything they can to protect him from cold south winds, from rain, and from insect pests. He can express aggression freely; he is not forced to walk or talk early; weaning is not a traumatic experience. In short, the infant is rarely punished or frustrated. Hence the conditions existing in infancy are not favorable for giving rise to the food anxiety manifested in adulthood.

After weaning, however, conditions change, and somewhat abruptly. However gradual parents try to make the transition from infancy to childhood, it is not always possible. Once the child has ceased to nurse, his food supply becomes uncertain; he begins to feel his first serious hunger pangs. His father may have obtained nothing on the hunt; he may have brought home only varieties of game which are taboo for a child to eat; he may have secured only a small amount of game, not sufficient to completely nourish his family; rain or flood may have prevented him from making an expedition in quest of food. Consequently, after the child is weaned, the response of crying which formerly always resulted in food is no longer always rewarded because there may be no food present at the moment. As the child grows older and more independent of his parents, the periods of actual food deprivation become more frequent and more intense. Younger siblings appear in the family and receive preferential treatment. Accompanying the pangs of hunger are the sufferings of fatigue and pain. The child is no longer carried, but must walk long distances with his parents in quest of food. No longer does he receive protection from cold south winds, from rain, and from insect pests. His feet become filled with spines. He suffers from skin worms, scorpion bites, and lack of sleep.

These are the conditions which provide the learning situation out of which a strong appetite for eating and an intense realistic anxiety about food arise in the Siriono child. These secondary drives develop soon after weaning and rise in intensity as the child grows older and more independent of his parents. By the time a youth reaches the age of 10, he is already manifesting

¹⁴ For an excellent discussion of anxiety and conflict, see Mowrer, 1940, pp. 126-128.

most of the signs of adult behavior toward food. In general, he is aggressive in all matters that pertain to food. He fights and quarrels for his share of food; he manifests a strong reluctance to share food; he wolfs his food; he eats principally at night; during the day he may steal off in the forest to eat; he eats when he is ill or not hungry; he lies about food; he even dreams about food. Indeed, if the Siriono had developed eschatological concepts, the afterworld would probably be a place where food, above all things, would be found in abundance and plenty.

In addition to the above-mentioned individual responses, which we may regard as direct manifestations of hunger frustration and anxiety in Siriono society, it appears that these conditions likewise occasion indirect manifestations by which we may characterize the society as a whole. Culturally, Siriono society exists on a very backward level. Technology is sparse; art is almost absent; social and political organization are relatively simple; there is an unconcern for intellectual and speculative matters. While unquestionably many factors—perhaps hundreds—operate to produce these conditions, yet it seems likely that the preoccupation with food problems—resulting in what we have called hunger anxiety—is one of the most significant ones. From my observations among the Siriono most of the native's time is spent on the quest for food or resting from it; under conditions of this kind, little seems to remain for the pursuit of other activities. While it is dangerous to generalize about such complex problems it does not seem likely that highly elaborated cultures would emerge under conditions similar to those found among the Siriono. Rather, cultures would change slowly and remain on a backward level. This is precisely what the Siriono data indicate.

In Siriono society we note, moreover, what appears to be a dominance of hunger over all other primary drives, except possibly that of fatigue. The Siriono, of course, do not suffer from lack of air or water, so such needs can be largely discounted as strong motivating forces in the society. But the dominance of hunger over sex seems unmistakable. While the drive of sex is seldom frustrated to any great extent, it is mobilized largely through the drive of hunger. The family is founded on an economic basis. Marital partners are secured by providing food and economic security. Extramarital sex partners are acquired

primarily through rewards of food. The preference for fat women over lean women and for food-gathering women over skilled potters or hammock makers suggests that even sexual appetites are based primarily on the drive of hunger. This is clearly observable among the women, who prefer good hunters to all other partners.

Actually, when food is scarce there is little expression of sex. On one expedition which I made into the forest with the Siriono for a period of about 6 weeks, I observed that there was little sexual activity during periods of food deprivation, but that excessive activity followed periods of food satiation. This, coupled with other data, leads to the conclusion that periods of food deprivation are generally accompanied by sexual abstinence while periods of food satiation are followed by sexual excesses. Such behavior seems to indicate the dominance of hunger over sex in Siriono society.

While the problem of the relationship between primary drives needs much further investigation, both in our own and in other societies, it seems as if Siriono society compensates its members for suffering from intense hunger frustration by allowing them great license in the realm of sex. I frequently observed that children were shown greater love when they were suffering from hunger, fatigue, or pain than at other times. With young children love was constantly used as a palliative. So, too, in adulthood sex freedom may compensate for hunger frustration.

Another indirect consequence of hunger frustration is that the strongest secondary drives among the Siriono seem to be those based on the primary drive of hunger. The strong appetite for eating has already been mentioned. Prestige, too, though not a prominent secondary drive, is based primarily on a person's ability as a food getter. Chiefs are always good hunters. Sexual appetites are also founded to some extent on the drive of hunger. Finally, the most aggressive behavior is expressed in terms of and over questions of food, and anxieties seem to center principally around the satisfaction of hunger.

Indeed, if the psychoanalysts are correct in their interpretations of behavior in our own society, the situation found among the Siriono is in many respects reverse. While the strongest secondary drives and anxieties in our own society arise from sex frustration, among the Siriono they may arise

from hunger frustration, and while food often compensates for sex deprivation in our own society, among the Siriono love appears frequently to serve as a compensation for hunger. Hence it would seem unsafe to generalize the findings of psychoanalysis, based on data from our own society, to other societies where drive conditions are not comparable.

The treatment of the sick and the aged in Siriono society appears indirectly to reflect hunger frustration. When a person becomes too old or too sick to hunt, to gather food, to bear children, or otherwise to take an active role in the society, he becomes a liability. If treated indulgently, the sick and aged might prove such a burden as actually to threaten the survival of the group. Consequently, people who are extremely ill or decrepit and whose period of usefulness is over are abandoned to die.

It might seem strange that the Siriono do not follow a similar practice toward deformed infants. Attention has already been called to the fact that some 15 percent of native infants are born with clubfeet. Considering that only about one in five such infants reaches adulthood, marries, and raises a family, it is rather surprising that the Siriono do not kill or abandon them when they are born. But such is not the case. During infancy club-footed children are treated with as much love and respect as normal children. There are doubtless several reasons for this. In the first place, children enjoy a favored status in Siriono society. They are loved to excess and overindulgently treated. While a Siriono thinks nothing of abandoning the aged or sick adult, he would look with horror and disgust at anyone who abandoned or killed a child. In the second place, deformed infants, unlike the dependent aged, do not threaten the food supply of others. They nurse until they are about 3 years of age, and even as young children they eat much less than an aged adult. Finally, there is at least a 20 percent chance that a deformed infant will grow up to be a useful member of society, while it is a certainty that an aged dependent will always remain a burden.

It is probably true that magical practice in Siriono society is likewise largely a function of hunger frustration. While the data from this aspect of culture are sparse, they relate principally to the quest for food. Attention has already been

called to the fact that hunters do not eat the flesh of certain animals that they themselves kill for fear that these animals will not return to be hunted by them. They also hang up the skulls of the animals and the feathers of the birds which they bag for the same reason. They smear themselves and their arrows with uruku, glue feathers into their hair, etc., to attract game. Men let blood to make themselves more valiant hunters; women, to make themselves more valiant collectors. Such magical behavior seems largely to be a reflection of the disparity between the constantly recurring hunger drive and the means of satisfying that drive. Lacking realistic techniques for insuring his food supply, the native resorts to magical practices to secure it. Given the conditions that exist, it is surprising that food and hunting magic have not become even more highly elaborated.

It is significant to note that there appears to be an almost complete lack of sex magic among the Siriono. The reason for this may be that the sex drive, unlike the hunger drive, is seldom frustrated to any great extent. The Indians rarely lack partners. Hence the native feels no need to rely on magical practice to lessen his sexual tensions. In fact, this type of anxiety seems to be remarkably low in Siriono society. Such manifestations as excessive indulgence, continence, or sex dreams and fantasies are rarely encountered except when motivated by a condition of hunger frustration.

The relative cohesiveness of the Siriono kin groups, the nuclear and extended families, as compared with the local group or band, seems also to stem principally from the condition of hunger frustration. While it is true that in most primitive societies kin groups are more closely knit than other social groups, the reasons for this may vary widely from one society to another. The important fact to consider here is that among the Siriono family solidarity seems to spring primarily from a lack of economic security. The supply of food is often not sufficient for distribution outside of the nuclear family and almost never sufficient for distribution outside of the extended family. Under conditions of this kind the local group or band becomes relatively unimportant as a social group. Except for supplying sex and marital partners, it has few functions. Practically all other functions are performed by or within the family. In short, the family embodies almost the totality of culture.

Finally, the personality of the adult Siriono is itself a logical consequence of a lifelong struggle to secure enough to eat. His early education in the family, his later contacts with his fellow tribesmen, and his final exposure to a harsh and rigorous environment all teach him that to survive he must be aggressive, individualistic, and uncooperative. These are the outstanding personality traits of the adult Siriono. The strong dependency relationships formed in infancy and early childhood do not persist. Gradually but prematurely they are displaced by traits of independence, so that when an Indian has reached adulthood he displays an individualism and apathy toward his fellows that is formidable.

The apparent unconcern of one individual for another—even within the family—never ceased to amaze me while I was living with the Siriono. Frequently men would depart for the hunt alone—without so much as a good-by—and remain away from the band for weeks at a time without any concern on the part of their fellow tribesmen or even their wives. On one occasion Ndekai, his wife, and their clubfooted son stayed away from the band for 6 weeks, wandering from one place to another in search of food. When they left they told no one about their plans, and while they were gone, no one showed the least concern about them. After returning from such a long absence, Ndekai was not even greeted by his tribesmen, although they eagerly tried to secure some of the meat he brought back with him. Such experiences indicate that were it not for the fact that the band supplies sex and marital partners, the family could be an independent social group among the Siriono.

Unconcern in one's fellows is manifested on every hand. On one occasion Ekwataia, a cripple who, although he was not married, had made an adjustment to life, went hunting. On his return darkness overcame him about five hundred yards from camp. The night was black as ink, and Ekwataia lost his way. He began to call for help—for someone to bring him fire or to guide him into camp by calls. No one paid heed to his requests, although by this time he was but a few hundred yards from camp. After about half an hour, his cries ceased, and his sister, Seáci, said, "A jaguar probably got him." When Ekwataia returned the following morning, he told me that he had spent the night sitting on the

branch of a tree to avoid being eaten by jaguars. His sister, however, although she manifested a singular unconcern for his survival the night before, complained bitterly that he gave her such a small part of his catch.

Such traits of character as have just been mentioned in no way indicate that the average Siriono is maladjusted and unstable. On the contrary, he seems to have made a relatively stable adjustment to harsh environment and to a culture that offers him little reward. The Siriono data would indicate, however, that man in the raw state of nature—and the Siriono may be regarded as the quintessence of such a man—is anything but cooperative, generous, submissive, or kind.

By way of recapitulation and conclusion a number of generalizations are suggested for further refinement and investigation in other societies where conditions of food insecurity and hunger frustration are comparable to those found among the Siriono.

(1) Such societies will be characterized by a general backwardness of culture. A concern with food problems will so dominate the society that other aspects of its culture will be little developed.

(2) The primary drive of hunger will dominate all other basic drives.

(3) The sex drive will be mobilized principally through the drive of hunger.

(4) The food quest will be painful and fatiguing.

(5) Secondary drives generally will be little elaborated.

(6) The strongest secondary drives will be those based on the primary drive of hunger.

(7) Appetites for eating will be strong.

(8) Anxieties about food will be intense.

(9) Aggression will be expressed largely in terms of food; if not, such aggression will be so severely punished that it will be almost entirely repressed.

(10) Prestige will be gained and status maintained largely by food-getting activities.

(11) Positions of power and authority will be occupied by individuals who are the best providers of food.

(12) Etiquette and ritual with respect to food will either be lacking or it will be elaborated to a pronounced degree.

(13) Fantasies and dreams about food will be common; if not, the subject of food will be so

repressed that food will not appear as a symbol in dreams.

(14) Magical practice will be devoted principally to increasing and insuring the supply of food.

(15) The most rewarding behavior in the society will be that which reinforces the hunger drive.

(16) There will be a tendency to kill, abandon, neglect, or otherwise dispose of the aged, the deformed young, and the extremely ill. If not, such dependents will occupy a favored status in the society.

(17) Kin groups will be more cohesive than all other social groups and will perform a greater number of significant functions than local or other internal social groups.

BIBLIOGRAPHY

- BENEDICT, RUTH.
1934. *Patterns of culture*. Boston and New York.
- CARDUS, JOSÉ.
1886. *Las Misiones Franciscanas entre los infieles de Bolivia*. . . . Barcelona.
- DOLLARD, JOHN. See MILLER, N. E. . . .
- DUBOIS, CORA.
1944. *The people of Alor*. . . . Minneapolis.
- FORD, CLELLAN S.
1945. *A comparative study of human reproduction*. Yale University Publications in Anthropology, No. 32.
- GORER, GEOFFREY.
1938. *Himalayan village*. . . . London.
- HERZOG, THEODOR.
1910. *Beitrage zur Kenntnis von Ostbolivien*. Petermanns Mitt., vol. 56, pt. 1, pp. 136-138, 194-200.
- JESUITS. LETTERS FROM MISSIONS.
1781. *Lettres édifiantes et curieuses écrites par des Missionnaires de la Compagnie de Jésus*. 26 vols. Paris.
- KELLER, A. G. See SUMNER, W. G. . . .
- LETTRES ÉDIFIANTES. . . . See Jesuits, Letters from Missions.
- LINTON, RALPH.
1945. *Cultural background of personality*. New York.
- MALINOWSKI, BRONISLAW.
1939. *The group and the individual in functional analysis*. Amer. Jour. Soc., vol. 44, No. 6.
- MEAD, MARGARET.
1935. *Sex and temperament in three primitive societies*. New York.
- MÉTRAUX, ALFRED.
1942. *The native tribes of eastern Bolivia and western Matto Grosso*. Bur. Amer. Ethnol., Bull. 134.
- MILLER, NEAL E., and DOLLARD, JOHN.
1941. *Social learning and imitation*. New Haven.
- MOHRER, O. H.
1940. *Anxiety: Some social and psychological implications*. In *Papers Presented before the Monday Night Group, 1939-1940*, pp. 122-144. New Haven, Institute of Human Relations. (Mimeographed.)
- MURDOCK, G. P.
1945. *The common denominator of cultures*. In Linton, Ralph (ed.), *The science of man in the world crisis*. New York.
- NORDENSKIÖLD, ERLAND.
1911. *Die Siriono-Indianer in Ostbolivien*. Petermanns Mitt., vol. 57, pt. 1, pp. 16-17.
- ORBIGNY, ALCIDE D'.
1835-47. *Voyage dans l'Amérique Méridionale*. 9 vols. Paris. Vols. 1-3, pt. 1, *Partie historique 1835-44*. . . . Vol. 4, pt. 1, *L'homme américain (de l'Amérique Méridionale)*. . . . 1839.
1845. *Fragment d'un voyage au centre de l'Amérique Méridionale*. . . . Paris.
1907. *Estudios sobre la geologia de Bolivia*. La Paz.
- RADWAN, EDUARD.
1929. *Einiges über die Sirionos*. Ztschr. f. Ethnol. vol. 60, pp. 291-296.
- RYDÉN, STIG.
1941. *A study of the Siriono Indians*. Göteborg.
- SCHERMAIR, ANSELM.
1934. *Kurze mitteilungen über die Siriono-Indianer im ostlichen Bolivien*, *Anthropos*, vol. 29, pp. 519-521.
- SNETHLAGE, EMIL HEINRICH.
1936. *Nachrichten über die Pauserna-Guarayú, die Siriono am Rio Baures und die S. Simonianes in der Nähe der Serra S. Simon*. Ztschr. f. Ethnol., vol. 67, pp. 278-293.
- SUMNER, WILLIAM GRAHAM, and KELLER, A. G.
1927. *The science of society*. 4 vols. New Haven.
- WEGNER, RICHARD N.
1928. *Die Quruñgu'a, ein neuentdeckter Stamm primitivster Kultur ohne artikulierte und grammatikalische sprache in Ostbolivien*. Phoenix, Ztschr. Deutsche Geistesarbeit für Südamerika, Jahrg. 14, Hefts 4 and 5, 369-384. Buenos Aires.
1931. *Zum Sonnentor durch altes Indianerland*. Darmstadt.
1932. *Ostbolivianische Urwaldstämme*. *Ethnologischer Anzeiger*, vol. 2, pp. 321-340. Stuttgart.
- 1934 a. *Bemerkungen zu dem Artikel von P. Anselm Schermair, O. F. M. Kurze Mitteilungen über die Siriono-Indianer im östlichen Bolivien*. *Anthropos*, vol. 29, pp. 814-817.
- 1934 b. *Indianer-Rassen und Vergangene Kulturen*. Stuttgart.
- 1934 c. *Die Quruñgu'a und Siriono*. *Internatl. Cong. Americanists Proc.*, vol. 24, pp. 161-184.
- WHITING, JOHN W. M.
1941. *Becoming a Kwoma; teaching and learning in a New Guinea tribe*. New Haven.

INDEX

- Abortion, absence of, 6.
Adoption, 49.
Adultery:
 frequency of, 61.
 punishment of, 61.
 Siriono concept of, 64.
Adulthood:
 activities of, 81-85.
 ceremonies of, 83-84.
 concept of, 83.
Aged, treatment of, 85, 97.
Aggression:
 at drinking feasts, 39.
 between cowives, 49-50.
 between husband and wife, 50.
 dissipation of, by hunting, 62.
 expressed in terms of food, 96, 98.
Agriculture, native practice of, 28-29.
Aguaf fruit:
 collection, 28.
 preparation, 35.
Airplanes, native beliefs about, 67.
Alligator, hunting of, 26.
Ambaibo tree (*Cecropia* sp.), uses of, 7, 11, 12.
Anaconda snake, 7.
 taboo on meat of, 33.
Animal husbandry, 29-30.
Animals:
 domestic, 29-30.
 hunting of, 23-27.
 in folklore, 46-47.
 knowledge of, 47.
 magical beliefs about, 91.
Animal teeth:
 necklaces of, 19.
 tools of, 14.
 used in bloodletting, 69.
Anteater, hunting of, 26.
Ants, as pests, 7.
Anxiety:
 about food, 30, 93-99.
 about sickness, 86.
 definition of, 94.
Armadillo, 7.
 beliefs about, 66.
 hunting of, 26-27.
Arrows:
 manufacture, 15-17.
 repair, 17.
 size, 16.
Art, 44.
Ashes:
 use of, in bloodletting ceremony, 84.
 used for purification, 70, 73.
Assaf palm (*Euterpe oleracea*), 2, 7, 28.
Baby slings:
 for carrying children, 43.
 for decoration, 69, 72.
 manufacture of, 12.
Bamboo, 8.
 drinking vessels of, 37, 38.
 use in arrow making, 15-17.
 use of, as a knife, 14, 68.
Band, 50-51:
 as a kin group, 50.
 composition of, 51.
 functions of, 51.
 territories of, 51-52.
Barrace, Cyprian, 9.
Basketry, 12.
Bats, as pests, 7.
 vampire, 40.
Bauré Indians, 8.
 Siriono fear of, 63.
Baures, village of, 4, 6, 9.
Benedict, Ruth, 93.
Bennett, Wendell, 4.
Bloodletting, 20.
 after childbirth, 69, 72.
 ceremonial, 83-84.
 in curing, 87.
Body mutilation, 20, 83-84.
Bows:
 manufacture, 14-15.
 method of drawing, 15.
 size, 15.
Bowstring, manufacture and application of, 15.
Bridge building, 43.
Burden carrying, 27, 43.
Bushmaster snake, 7, 32.
Calabashes:
 disposal of, at death, 87.
 preparation of, 13.
 uses of, 13, 38.
Camotes. *See* Agriculture.
Cardus, José, 10.
Casarabe, 2, 9, 10, 37, 51, 66, 74, 86.
Celestial phenomena, native explanations of, 47.
Ceramics, 12-13.
Ceremonies:
 bloodletting, 20, 83-84.
 childbirth, 67-70.
 funeral, 87-89.
 magical, 91.
 marriage, 81.
 naming, 74-75.
 puberty, 80-81.
Cerro Blanco, 6, 7.
Cerro San Simón, 7.
Chieftainship, 59-60.
Childbirth, 67-73.
Childhood, 77-80.
Child, 1, 94.
Chiquitos region of Bolivia, 6, 7.
Chiriguano Indians, 10.
Chonta palm, 7.
 fruits of, as food, 28.
 seeds of, as necklaces, 20.
 tools of, 14.
 weapons of, 14-17.
Chuchio (*Gynerium sagittatum*), 8.
Cleanliness training, 75-76.
Clothing, lack of, 19.
Clubfootedness:
 frequency of, 8.
 treatment of clubfooted children, 76.
Coati, 7.
 hunting of, 26.
Collecting, 27-28.
Cooperation:
 in housebuilding, 17-18.
 in hunting, 23, 25.
 lack of, 98.
Coquino fruit, 7, 22, 28, 86.
Cormorant, 7, 24.
Cotton:
 planting of, 29.
 spinning, 11.
 use of string in decoration, 20, 69.

- Counting, native ways of, 47-48.
 Couvade, practice of, 68-70.
 Cross-cousin marriage, 81.
 Cross-Cultural Survey, 1.
 Curassow, 7.
 feathers of, used in arrow making, 16.
 used in decoration, 19, 69.
 hunting of, 23.
- Daily round, 40-41.
 Dancing, 44-46.
 Death, customs of, 87-89.
 Deer, 7.
 hunting of, 25.
 Deer flies, as pests, 7.
 Diarrhea, treatment of, 87, 88.
 Diet, 30-32.
 after childbirth, 72.
 at puberty, 80.
 during bloodletting ceremonies, 84.
 during mourning, 88.
 during pregnancy, 66.
 of infants, 76.
 Digging stick, manufacture and uses, 14.
 Disease:
 causes of, native belief, 86.
 knowledge of, 86.
 prevalence of, 85-86.
 signs of, 86.
 treatment of, 86-87.
 Division of labor, by sex, 41-42.
 Divorce, 83.
 Dollard, John, 1, 4, 92, 93.
 Dreams, native interpretation of, 91.
 Dress, 19-21.
 Drinking feasts, 37-39.
 aggression at, 62.
 Drives:
 in relation to culture, 92-99.
 primary, 92.
 secondary, 92.
 DuBoise, Cora, 93.
 Ducks, 7.
 hunting of, 24.
- Eating, 36.
 Education, of children, 77-80.
 El Carmen, village of, 2, 6, 9.
 Endogamy, 81.
 Evil spirits, in religious belief, 90.
 Exogamy, 81.
 Exploitative activities, 21-30.
- Family:
 extended, 50.
 nuclear, 49.
- Fauna, 7.
 Feathers:
 lack of featherwork, 12.
 use of, in decoration and ornament, 19, 69, 79, 88.
 use of, in making arrows, 16.
- Fire, 11.
 Fishing, 27.
 Flora, 7-8.
 Folklore, 46-47.
 Food, 30-32.
 anxiety about, 94.
 as a lure in obtaining sex partners, 64.
 eating of, 36.
 insults in terms of, 39.
 of babies, 76.
 preparation of, 34-35.
 preservation and storage of, 34.
 seasonal, 22.
 taboos, 32-34, 66, 68, 72, 80, 84.
- Ford, Clellan S., 1, 4, 93, 94.
 Fowling, 24.
 Fruits, wild, 7.
 as food, 35.
 collection of, 27-28.
 Fuel supply, 30.
- Gestalt, use of in native mathematics, 48.
 Glue, manufacture of, 11.
 Gnats, as pests, 7.
 Gorer, Geoffrey, 93.
 Group marriage, 81.
 Guan, 7.
 hunting of, 24.
 Guaraní Indians, 9.
 Guarayos, Indians, 10, 63.
 Missions of, 3, 6, 9.
- Hair:
 cut, 20.
 depilation, 20-21, 69, 76.
 style, 20, 69.
- Hammock, manufacture of, 11-12.
 Harpy eagle, 7.
 down of, used in magic, 91.
 feathers of, used on arrows, 16.
 taboo on meat of, 33.
- Hearths, lack of, 11.
 Hepner, Lothar, 4.
 Herbal remedies, 87.
 Herzog, Theodor, 10.
 History, of Siriono, 8-10.
 Holmberg, Laura, 4.
 Honey:
 collection of, 28.
 use in making mead, 38.
- House:
 construction of, 17.
 furnishings, 18-19.
 size of, 18.
 type, 17.
- Hull, Clark, 1, 4.
 Hunting, 23-27.
- Imitation:
 learning by, 75.
 of animals, 23.
- Incest:
 occurrence of, 61.
 punishment of, 61.
 rules of, 64-65.
- Individualism, of Siriono, 60, 98.
 Infancy, 75-76.
 Infanticide, lack of, 66.
 Ingroup conflict, 61-62.
 Inheritance:
 of chieftainship, 21, 60.
 of property, 21.
- Itonama:
 Indians, 8.
 River, 6.
- Jaguar, 7.
 equated with dog, 29.
 hunting of, 26.
 mythical, 47.
- Jesuits, 9.
 Justice, informal and private nature of, 61.
- Keller, A. G., 93.
 Kinship:
 behavior, 56-58.
 charts, 53, 55, 56.
 system, 52-56.

- Law, native, 60-61.
 Leigue, Adolfo, 4.
 Levirate, 81.
 Life cycle, 63-89.
 Lightning, native explanation of, 47.
 Linton, Ralph, 93.
 Loayza Beltrán, Carlos, 4.
- Macaw, 7.
 hunting of, 24.
- Magdalena, village of, 4, 6, 9.
 Magic, native practice of, 91.
 Maize. *See* Agriculture.
 Malinowski, Bronislaw, 4, 93.
 Manioc. *See* Agriculture.
 Marriage, native customs of, 81-83.
 Massage, use of in curing, 87.
 Materna, Francisco, 3.
 Matrilocal residence, 81.
 Mead, manufacture and drinking of, 38-39.
 Mead, Margaret, 93.
 Menstruation, 65.
 Methods, of field work, 3.
 Métraux, Alfred, 4, 10.
 Miller, Neal E., 1, 92, 93.
 Miscarriage, 66-67.
 Mist, native explanation of, 47.
 Mobility, extent of, 42-43.
 Mojo Indians, 8.
 Mollusk shells, as tools, 14.
 Monkeys, 7.
 hunting of, 24.
- Monsters, native beliefs about, 90.
- Moon:
 as a culture hero, 46, 47.
 rays of, cause of blindness, 18.
- Moré Indians, 8.
 Mortars, making and uses of, 13.
 Mosquitoes, as pests, 7.
 Motacé palm, 7.
 baskets and mats of, 12.
 heart of, used as food, 22, 27, 35.
 roofing of leaves of, 17-18.
- Mourning, customs of, 87-89.
 Mowrer, O. H., 94, 95.
 Multiple births, 70.
 Murder, occurrence and punishment of, 60-61.
 Murdock, G. P., 1, 4, 92, 93.
 Music, 44-46.
 Mussel shells, as tools, 14.
 Mythology, sparse development of, 46.
- Naming, 74-75.
 Narcotics, 37
 Necklaces, 19-20
 Nicknames, 74-75
 Nordenskiöld, E., 9, 10, 62
- Ornaments, 19-21, 69-70, 72-73
 Orbigny, Alcide d', 9, 43
 Osgood, Cornelius, 4
 Otero, Gustav, 4
- Paca, 7
 hunting of, 27
- Pacáy (*Inga* sp.), 7
 fruit as food, 22, 28, 35
- Pacobilla tree, 7
 fruit as food, 22, 28
- Palm cabbage, collecting of, 27
- Palometa fish, 7
 use of teeth as tool, 14
- Palo Santo tree, 7, 8
 Papaya. *See* Agriculture.
 Parrots, 7.
 hunting of, 24.
- Partridge, 7.
 hunting of, 24.
- Paternity, native concepts of, 73]
- Peccary, 7.
 hunting of, 24-25
- Physical type, Siriono, 8
- Pipes, manufacture of, 13.
- Planets, native concepts of, 47.
- Plants, Siriono knowledge of, 47.
- Play groups, children's, 79.
- Polygyny, practice of, 81, 82.
- Pottery, manufacture of, 12-13.
- Pregnancy, 65-67.
- Preparation of food, 34-35.
- Preservation of food, 34.
- Prestige, methods of gaining, 58-59.
- Property, 21.
- Puberty rites, 80-81.
- Quarrels:
 frequency of, and reasons for, 61-62.
 within the family, 49-50.
- Radwan, Arthur, 10.
- Rainbow, native explanation of, 47.
- Rape, occurrence and punishment of, 61.
- Reciprocity, 60.
- Religion, 90-92.
- Reproduction, native ideas and practices of, 65-67.
- Richards, Abraham, 44.
- Richards, F. P., 2, 4.
- Rivers:
 Rio Blanco, 6, 7, 9.
 Rio Grande, 6, 9.
 Rio Guaporé, 6, 9.
 Rio Itenez, 6, 7, 9.
 Rio Itonama, 6.
 Rio Machupo, 6.
 Rio Madeira, 6.
 Rio Mamoré, 6, 9.
 Rio Negro, 6.
 Rio Piráy, 6.
 Rio San Joaquín, 6.
 Rio San Martín, 6.
 Rio San Miguel, 6, 9.
 Rio San Pablo, 6.
- Rousseau, René, 4.
- Rydén, Stig, 10.
- Salas, Horacio, 4.
- Salt, 35.
- Salutations, lack of, 40.
- Scarification:
 after childbirth, 69.
 in curing, 87.
- Schermair, Anselm, 10, 91.
- Scorpions, as pests, 7.
- Seasonal cycle, 21-22.
- Sex, native concepts and practices of, 63-65.
- Shellfish, 7.
- Silva Sánchez, Luis, 2, 4, 89.
- Singing, 44-46.
- Siringueros (rubber tappers), 63.
- Social control, 60-61.
- Social organization, 49-63.
- Social Science Research Council, 1, 4.
- Social stratification, 58-59.
- Solares, A., Medardo, 67.
- Solares A., Napoleón, 4.
- Sororate, marriage by, 81.
- Soul, beliefs about, 91.
- Spindles, 11.
- Spindle whorls, manufacture of, 13.
- Spinning, 11.
- Stalking of game, 23.
- Stars, native explanation of, 47.

- Storage of food, 34.
Streams, crossing of, 43.
Sumner, W. G., 93.
Swimming, 43.
- Tapir, 7.
 hunting of, 25-26.
- Technology, of the Siriono, 11-21.
- Teknonymy, 51.
- Textile industries, 11-12.
- Theft, occurrence and punishment of, 61.
- Thunder, native explanation of, 47.
- Time, native concepts of, 48.
 reckoning, 48.
- Tobacco:
 planting, 29.
 preparation, 37.
 smoking, 37, 38.
- Tools, manufacture and uses of, 14.
- Tortoises, 7.
 use of, as food, 28, 34.
- Toucan, 7.
 feathers of, for decoration, 19, 69.
 hunting of, 24.
- Trails, 42.
- Transportation, 42-44.
- Travel, 42-44.
- Trinidad, city of, 2, 6.
- Tupian language, 8.
- Twins:
 beliefs about, 70.
 birth of, 70-73.
- Uruku (*Bixa orellana*):
 use in decoration, 11, 19.
 use in healing, 87.
 use in magic, 91.
- Utensils, 13.
- Vultures, 7.
 eating of, 33.
- Warfare, 62-63.
- Wasps, as pests, 7.
- Watercraft, lack of, 42.
- Water supply, 30.
- Weaning, 76.
- Weapons, 14-17.
- Wegner, Richard, 4, 10, 91.
- Whistling, 23.
- Whiting, John W. M., 1, 4, 93, 94.
- Women, position of, 59, 84-85.
- Wood ticks, as pests, 7.
- Work, 40-41.
- Wrestling, 39.
- Yale University, 1, 4.
- Yanaigua Indians, 9.
 Siriono fear of, 63.

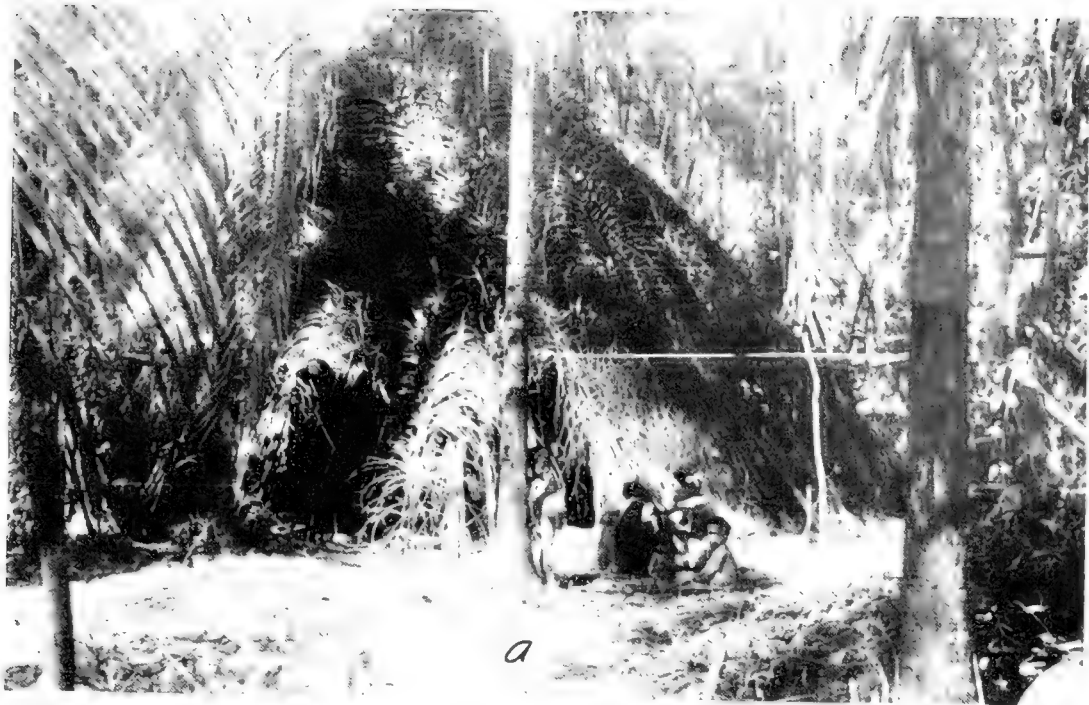

PLATE 1.—*a*, Typical Siriono hut inside of forest (Tibaera). *b*, Pregnant woman, Eakwantú; later she gave birth to twins (Tibaera). *c*, Erúba-erási (Sick-face), a Siriono boy about 14 years old (Tibaera).

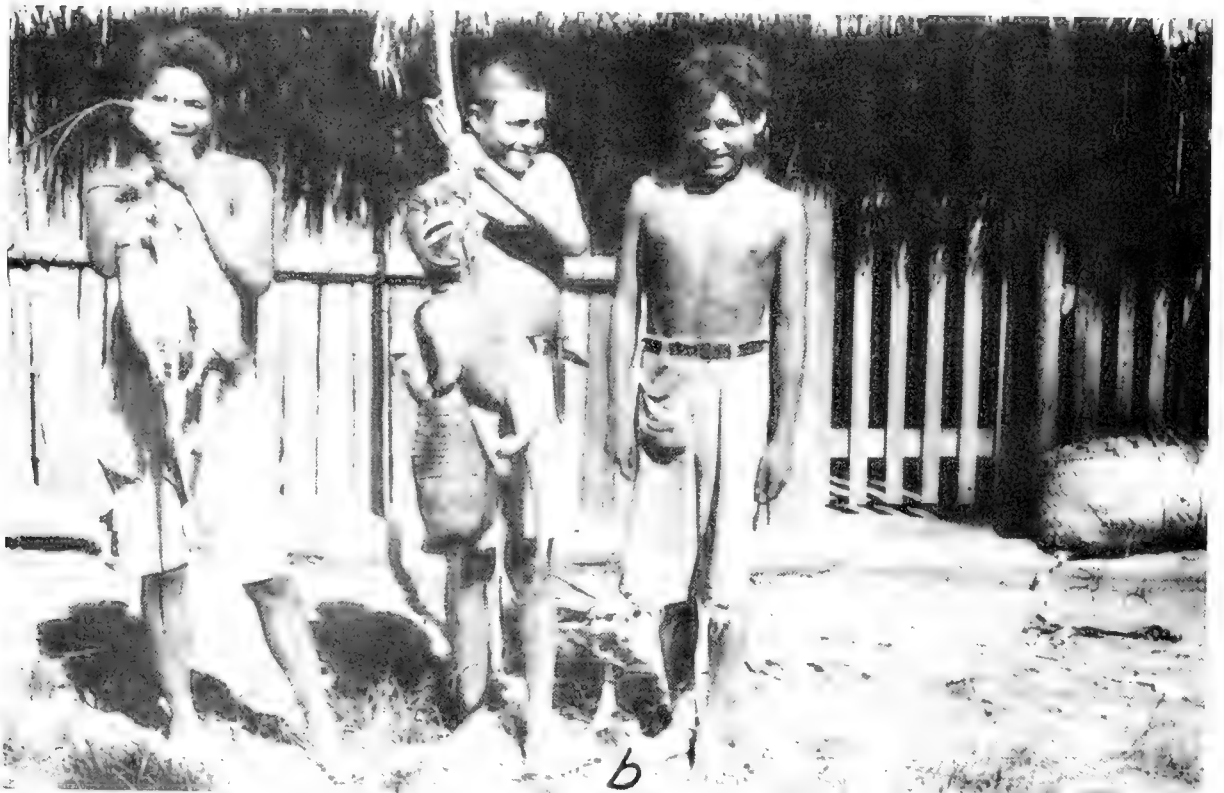

PLATE 2. *a*, Simono chief and his five wives outside of primitive hut at Casarabe. *b*, Simono boys at Casarabe with catch of armadillos and anteaters.



PLATE 3. - *a*, Enfa demonstrating the method of carrying baskets by men (Tibaera). *b*, Yikmádu watching one of his sons draw the bow (Tibaera). *c*, Bringing in firewood from forest in carrying baskets (Tibaera). *d*, A hunter who has retrieved a curassow (Tibaera).



PLATE 4. *a*, Saeú, Coati and Aiti (Close-at-hand) returning from the hunt with coatis and monkeys (Tibagra). Note length of arrows. *b*, Back view of same hunters returning from the forest, showing how they carry in game (Tibagra).



PLATE 5.—*a*, A hunter leaning on a pole (Tihæra). *b*, Etakûi cutting up a tortoise (Tihæra).



PLATE 6. *a*, Cutting up monkey meat outside of hut (Tibaera). *b*, Monkey meat roasting in the jungle (Tibaera).



PLATE 7.—a. A mother demonstrating how she carries her child in the baby-sling. b. Father of woman, c. 1, decorated with animal teeth necklaces and feathers.





3 1151 00184 7387

Date Due



DATE DUE
HOPKINS
ARY
JAN 19 1958
JAN 19 1958
JAN 19 1958

JAN 19 1958
06 30

370810129587

START SC ANALYSIS
HERE