

9
FGD
18

The Quarterly Journal of The Florida Academy of Sciences

A Journal of Scientific Investigation and Research

Editor

H. K. WALLACE

Associate Editors

J. C. DICKINSON, JR.

DONALD R. DYER

JOHN W. FLOWERS

VOLUME 17

Published by

THE FLORIDA ACADEMY OF SCIENCES

Gainesville, Florida

1954

DATES OF PUBLICATION

Number 1—June 9, 1954

Number 2—August 18, 1954

Number 3—October 13, 1954

Number 4—February 18, 1955

CONTENTS OF VOLUME 17

NUMBER 1

Relations of People to Each Other. <i>By Raymond F. Bellamy</i>	1
Crime and Social Research. <i>By Clyde B. Vedder</i>	11
Some Methods for the Treatment of Problems in Dimensional Geometry. <i>By Howard D. Allen</i>	19
The Multitrichomate Oscillatoriaceae of Florida. <i>By</i> <i>C. S. Nielsen</i>	25
A Simplified Synthesis of 3-amino-4-nitrobenzoic Acid and Ethyl 3-amino-4-nitrobenzoate. <i>By Morris J. Danzig and</i> <i>Harry P. Schultz</i>	43
A Vegetative Key to the Native and Commonly Cultivated Palms in Florida. <i>By Hugh Nelson Mozingo</i>	46
A Method for Preparing and Mounting Thin Gross Sections of Human or Other Large Brains. <i>By Granville C. Fisher and</i> <i>Frederic D. Garrett</i>	55
Membership List of the Florida Academy of Sciences	59
News and Comments	71

NUMBER 2

Florida's Resource-Use Education Problems. <i>By Henry F.</i> <i>Becker</i>	73
Nineteenth Meeting of the Florida Academy of Sciences	82
A Rapid Colorimetric Test for Organic Matter in Certain Mineral Soils. <i>By Seton M. Edson and George D. Thornton</i>	83
The Multitrichomate Oscillatoriaceae of Florida. <i>By C. S.</i> <i>Nielsen</i>	87
Boron in Florida Waters. <i>By Howard T. Odum and Bruce</i> <i>Parrish</i>	105
A New Crayfish from the Upper Coastal Plain of Georgia (Decapoda, Astacidae). <i>By Horton H. Hobbs, Jr.</i>	110
A Suggested Inorganic Fertilizer for Use in Brackish Water. <i>By Malcolm C. Johnson</i>	119
News and Comments	128

NUMBER 3

Studies of Fluorene Derivatives in Tumor Chemotherapy. <i>By Mary F. Argus and L. R. C. Agnew</i>	129
The Frustration-Aggression Hypothesis in Corrections. <i>By Vernon Fox</i>	140
Adult Fish Populations by Haul Seine in Seven Florida Lakes. <i>By Harold L. Moody</i>	147
A Regional Study of the Phosphate Industry. <i>By H. T. Grace</i> ..	168
A. A. A. S. Research Grant	181
Additions to the Known Fish Fauna in the Vicinity of Cedar Key, Florida. <i>By David K. Caldwell</i>	182
Notice of Annual Meeting	184

NUMBER 4

Additional Specimens of <i>Gavialosuchus americanus</i> (Sellards) from a New Locality in Florida. <i>By Walter Auffenberg</i>	185
Elected Officers for 1955	210
Studies in Stream Pollution Biology. I. A Simplified Ecological Classification of Organisms. <i>By William M. Beck, Jr.</i>	211
The Occurrence of Bison in Florida. <i>By H. B. Sherman</i>	228
A Description of the Larvae of <i>Ambystoma cingulatum bishopi</i> Goin, Including an Extension of the Range. <i>By Sam R. Telford, Jr.</i>	233
Anatomical Study of Slash Pine Graft Unions. <i>By Francois Mergen</i>	237
Modern Wholesale Market Facilities. <i>By Ray Y. Gildea, Jr.</i>	246
The Geoduck Clam in Florida. <i>By Verle A. Pope</i>	252
News and Comments	253
Index to Volume 17	254

Quarterly Journal

of the

Florida Academy of Sciences

Vol. 17

March, 1954

No. 1

Contents

Bellamy—Relations of People to Each Other	1
Vedder—Crime and Social Research	11
Allen—Some Methods for the Treatment of Problems in Dimensional Geometry	19
Nielsen—The Multitrichomate Oscillatoriaceae of Florida	25
Danzig and Schultz—A Simplified Synthesis of 3-Amino-4- Nitrobenzoic Acid and Ethyl 3-Amino-4-Nitrobenzoate	43
Mozingo—A Vegetative Key to the Native and Commonly Cultivated Palms in Florida	46
Fisher and Garrett—A Method for Preparing and Mounting Thin Cross Sections of Human or Other Large Brains	55
Membership List of the Florida Academy of Sciences	59
News and Comments	71



VOL. 17

MARCH, 1954

No. 1

QUARTERLY JOURNAL OF
THE FLORIDA ACADEMY OF SCIENCES

A Journal of Scientific Investigation and Research

Published by the Florida Academy of Sciences

Printed by the Pepper Printing Co., Gainesville, Fla.

The business offices of the JOURNAL are centralized at the University of Florida, Gainesville, Florida. Communications for the editor and all manuscripts should be addressed to H. K. Wallace, *Editor*, Department of Biology. All subsequent correspondence concerning manuscripts may be handled directly between authors and *associate editors*: J. C. Dickinson, Jr., Biological Sciences, Department of Biology and Florida State Museum; Donald R. Dyer, *Social Sciences*, Department of Geography; John W. Flowers, *Physical Sciences*, Department of Physics. Business communications should be addressed to R. A. Edwards, *Secretary-Treasurer*, Department of Geology. All exchanges and communications regarding exchanges should be addressed to The Gift and Exchange Section, University of Florida Libraries.

Subscription price, Five Dollars a year

Mailed June 9, 1954

THE QUARTERLY JOURNAL OF THE FLORIDA ACADEMY OF SCIENCES

VOL. 17

MARCH, 1954

No. 1

RELATIONS OF PEOPLE TO EACH OTHER¹

RAYMOND F. BELLAMY
Florida State University

Perhaps the best definition of sociology which has been formulated is that it is the science or at least the study of the relationships or influences between different people. These influences we designate as *interaction*, and interaction may be as simple as the effect of a sweet smile or a reproving frown, or it may be as vast and complex as the influence which one great section of mankind, say the Russians or the Chinese, have on other nations or peoples.

Interaction may be direct and immediate or it may function over great distances or periods of time. Some decades ago explorers came upon a tribe of African natives who had never even seen a white man, yet they were wearing cotton garments which were stamped "Marshall Field and Company, Chicago, Illinois." There had been marked interaction between the Negro who raised that cotton in Dixie and his remote cousin in African who wore it. Similarly, we are still feeling the influence of George Washington, Eli Whitney, Peter Cartwright, Napoleon, Julius Caesar, Shakespeare, Mohamet, Buddha, Jesus, and Moses

When the sociologist attempts to understand and explain or even describe the interactions of any peoples, he must be sensitive to the many factors which influence the forms which the interaction takes. The physical or geographic environment has a profound influence; we do not hunt for seals in Florida nor get our thrills out of mountain climbing. We take our delight in observing the scenery spread out on our bathing beaches, one of the advantages of which is that this scenery may become ambulatory or even

¹ Given at the annual meeting of the Florida Academy of Sciences at Gainesville, Florida, Dec. 11, 1952, as part of a symposium on the ecology of Florida.

amatory. But in spite of the claims of Huntington, Semple, and others, the physical environment will not suffice alone to explain the multitudinous reactions of mankind.

The hereditary factor is important, probably much more important than the psychologists of the last few decades have believed. If one inherits the stature of a midget, he will not be very successful as center on an ordinary college basketball team; if he inherits haemophilia he had best not engage in farming or machine trades, and if he inherits a black skin he probably will not play golf or attend an artist series in a southern town.

Just the number of people in a given area will affect the behavior therein. The writer taught a district school in the Bear's Paw Mountains of Montana one summer and met with rather unusual reactions. When he "rented" a vacant cottage for the summer, he could not prevail upon the owners to accept any rent. Similarly, a team of horses and wagon for a twenty-mile trip were freely provided, and the owners of a cow absolutely refused to accept any money for a quart of milk a day, although they did finally agree to let the recipient milk the cow. In later years the people of Cincinnati, New York, and Atlanta have hardly manifested the same type of behavior. The difference was simply that in Montana there was a sparse and scattered population while in the other places the opposite situation prevailed.

The cultural factors are equally important, and culture may be defined as anything artificial, differing thus from the behavior of the less intelligent but probably more noble and worthy lower animals. Culture and the products of culture are schools, medical services, and other institutions, all inventions, and everything which surrounds us except the mere animal impulses of our lives.

A special phase of culture is designated as social control which takes multitudinous forms, not only legal control embodied in our laws, but religious and moral teachings and convictions, folkways and customs, styles and fashions, public opinion, gossip, drill, and propaganda, all of which are disseminated by the press, radio and television, and such other media as sound trucks and wagging tongues.

Therefore, to understand and explain or describe the interactions between the people of Florida, we must keep in mind constantly all these lines of influences. Moreover, we must never forget that we do not find any one of our list functioning alone, but instead

they are all jumbled together into such a conglomerate mass that not even a platoon of Philadelphia lawyers could untangle them.

From the sociological standpoint, what might be called the secondary effects of all these factors is of greater interest than the primary effects, at least in many instances.

In north and west Florida the physical factors of soil, temperature, rainfall, and other physical factors suggest general farming, raising corn and cotton, tobacco in some regions, and we also find there lumbering, turpentine, and small-scale stock raising. These are the primary products of the physical factors. but they are merely the first link in what may be called a chain reaction. Cotton has always required a large amount of unskilled hand labor, and long ago this fastened slavery on the South. Had it been found that slave labor was efficient for cod fishing and for raising wheat and hay, then the North would have had slaves. The northern preachers would have found that Holy Writ sanctioned it, the school teachers would have believed in it, and it would have become an accepted part of the folkways. Conversely, had it been found that slave labor was unprofitable for cotton raising, then the South would have abhorred slavery and gray-clad men would have marched to war fired with a holy zeal to free their enslaved fellow men.

But it did not happen that way and cotton raising resulted in salvery for the South. While slavery as such is gone, many of its features are still common in the cotton-raising regions of North Florida. Here still lingers the share-cropper practice with all its attendant features. While the tractors, the gang plow, and even the Rust cotton picker have made inroads, the one-mule plow, even the one-mule farm is still quite common. In fact, many of the farms are so small that complicated machinery cannot be used profitably.

Some years ago the writer attempted to get the husband of a colored maid out of jail. He had been jailed for "jumping his contract," that is leaving his employer while still indebted to him. It was found that all that was necessary was to hire a lawyer and the case would be thrown out of court; but, as an informed member of the bar said, "If you don't get a lawyer, they'll send him up for three months sure." This was the typical and old familiar pattern of the cotton-raising region which is also associated with turpen-

ting and lumbering. There is more of it still existing than is usually realized.

Tobacco raising also necessitates hand work, and it should be no surprise that in tobacco-raising Gadsen County 56% of the population is made up of Negroes. This is the highest per cent of Negroes in any county except Jefferson which has 60%, and Jefferson is also an agricultural county.

It is in this tier of north central counties that lynchings occur most frequently. The secondary effects of the environment or the accompaniment of general agriculture is, to use sociological terms, superordination of the whites, and subordination of the Negroes. But again we must remember that many other factors enter the picture besides the geographical, such things as traditional practices and attitudes.

In this northern region there is a great gulf between the most prosperous group and the lowest economic class, be they white or black. In fact, the bottom economic layer of whites reaches to lower depths than the Negroes. The Negroes are coming up and they know it, and in general they make the best of their opportunities. As a rule, they have flowers in their yards and they decorate their rooms with pictures, curtains, rugs, etc. The dregs of the whites are going down and, in fact, they have gone about as far as they can go. They have no pride and make no attempt to do anything but just live. The conditions under which these people live are almost unimaginable. Their homes are never seen except by a very few who make it a point to look out into the byways and hedges. Back out of sight of our smooth paved highways are the dilapidated shacks in which these poverty-stricken whites live. There is no use to describe them; just imagine the worst, and what you imagine will be better than the reality.

Fishing villages have their own characteristic type of attitudes, but there is not too much uniformity in the patterns of the different fishing centers. For example, the practices and attitudes in a small community which is situated on a muddy beach where mullet fishing reigns differ greatly from those in such surroundings as at Miami Beach where fully-equipped boats take millionaire sportsmen out to catch sailfish and marlin.

Here cultural factors, among them legal control in the form of sanitary laws, enter the picture. Some of the mullet fishermen spend most of their time right in their seine yards, and have make-

shift shacks in which they sleep. The interior of some of these shacks is filthy beyond comment; one can hardly believe that human beings would sleep under such begrimed and stinking covers. Yet the trucks in which these men haul their mullet are scrupulously clean, much cleaner than the cars or even the homes of most of our leading citizens. Here custom, tradition, and law all combine. They put up with the filthy couches since they are looked upon as just make-shift temporary waiting places and therefore do not count. It must be noted that many well to do and fastidious duck hunters will take a nap in just such quarters, even if they would be horrified at the idea of allowing bedrooms in their own houses to get into such a state. On the other hand, the law provides for food inspectors to pass on the cleanliness of the fish trucks, and now the practice of keeping them clean has become a custom as well as obedience to law.

As mean as the conditions are under which these fishermen live, their native intelligence is not necessarily low. The writer has become closely acquainted with some of these people and has come to respect and admire them. In their conversations some of the fishermen gave evidence of having as open minds, as ready conceptions, and as intelligent an understanding as our university colleagues.

As noted above, there are many local differences. In some localities the Negroes are not allowed to do any commercial fishing and if they attempt it their boats and nets will be destroyed and they may suffer personal damage, while in other places the whites and Negroes work along side by side without friction.

In parts of North Florida the population is very sparse and this is also true of other sections of the state, such as the scrub palmetto wastelands of South Florida, and, in fact, large tracts in almost any part of the state. As might be expected, in these thinly populated regions there is a general lack of social stimulus. The importance of such elbow rubbing is far greater than is generally supposed, and it should not surprise us if in the thinly populated regions of Florida we find a particularly impressive degree of cultural lag. It takes expression in their religion, their education, their recreation, and in every phase of their lives, including their crimes.

In some of the little churches in these sparsely populated regions there may be found such things as a miniature trough filled with

sawdust into which the devout worshipper may spit his tobacco juice. And on occasion, a member of the church choir will be followed by her faithful dog who will lie down by the choir box and behave admirably during the service. Whether or not such dog receives spiritual uplift from the music and the sermon is not definitely known.

It is in such retarded communities that revivalism with its attendant phenomena of shouting, boistrous singing, and a form of dancing are found. We would not find this type of religious expression among the big property owners of West Palm Beach or in the chapel at Rollins College. Such wildly demonstrative church services are particularly common among the Negroes, not because they are Negroes, but because of the social and economic lives which they live. In fact, there is nothing in all Africa which is similar to this kind of religious service; it was typical among the European peasants and their American descendants at the time of our early colonial life, and it was from them that the Negroes received the pattern.

Lily Mitchell, in her study of the religious sects of Worcester, Massachusetts, found that the lower the economic status of a people, the more vociferous were their religious demonstrations, but there are other factors besides the economic one. All people crave excitement and the opportunity to give expression to their emotions. It may be secured by attending a symphonic orchestra, a meeting of an Academy of Sciences, shouting one's self hoarse at a football game or in many other ways. In the old West, the cowboys knew no other way than by riding furiously through town, yelling Whoopee, and firing their pistols into the air. In Florida and in most of the South, the whites of the thinly populated regions and the Negroes generally have a choice between two outlets—getting drunk and fighting or going to church and shouting—and frequently they do both. As the Negroes become more prosperous and better educated and secure privileges of participating in athletics and other interesting activities their religious expressions become less spectacular, and the same is true of the underprivileged whites.

Even the health of the people is affected greatly by the density of the population. There are Florida counties in which there has been no resident doctor for many years. As might be expected, in those counties there are many diseased tonsils, bad hearts, de-

fective teeth, eyes, and ears, and many other forms of bodily ills. A physician who served on the examining board during the last war stated that he had not examined a single man from one of these counties who was free from all these ailments. Under these circumstances, it should not be surprising that the people have their own particular attitudes toward medical services. Among the colored people there is frequent resort to root doctors and conjurers, the whites more frequently relying on as much calomel as can be piled up on a dime. It must be said, however, that such practices are nothing like as prevalent as they were a few years ago. Good roads, consolidated schools, radio programs, public health services, and other such present day innovations have done much to bring about changes in the attitudes and beliefs of the people.

As noted above, even the types of crime differ according to the local conditions. Throughout the northern portion of the state, as far south as much corn is grown, moonshining is quite typical. During prohibition it became something of a big business and certain brands, or the products of certain bootleggers, became famous over a wide region. That greatest of all compliments, imitation, was practiced and many gallons were sold under the false name of the famous brand. On the other hand, some of these stills were, and occasionally still are, no more elaborate than a kerosene can attached to a few feet of gaspipe which is made to run through a wooden trough filled with water. This is hardly typical of the South Florida cities where anything but a boat load of smuggled Cuban liquor would be scorned.

If, like Will Rogers, we are to believe what we read in the papers, some of these South Florida cities are the dwelling places, or at least the locale of operations of gamblers who carry on their business in size comparable to the national debt or the cost of war. Such things are not found in the more sparsely settled regions, but one may find there a lot of crap games and poker playing. Not only the presence of various forms of gambling, but the attitude toward them is significant. It should be remembered that the owner and proprietor of Bradley's Place, the former Monte Carlo of the East Coast was a devoutly religious man. The social environment in which he lived and from which he secured his beliefs and attitudes determined his convictions on this subject.

There are many things in the social behavior of Florida's citizens which seemingly resulted from mere chance. There is no easily ascertainable reason why the most wealthy tourists and sun hunters should have preferred the East Coast and those more closely approximating the middle class should have gone to the West Coast. Just possibly the fact that the West Coast is slightly warmer may have had some slight influence, but it is highly probable that this fact was not known by either group. Similarly, it would be difficult to say why the excessively wealthy tended to flock to West Palm Beach, those with sporting blood to Miami, old people to St. Petersburg, retired scholars to Orlando, and the residents of Florida, itself, to take their vacations typically in Daytona Beach. Presumably there were reasons back of all these, but they were so obscure that in most cases to all appearances it was mere chance. Some surface explanations may be given; for example, Rollins College has had much to do with enticing the scholarly and artistic to Orlando, but that just pushes the questions back to why Rollins should have located near Orlando and why it should have adopted this policy rather than Southern or Stetson.

Whenever these original trends were started, they gained impetus and have had far reaching effects. The yen for gambling and acting the playboy generally in the blood of the Miamians has resulted in race tracks. Jai Alai, million dollar golf courses, and certain other phenomena concerning which you are respectfully referred to the Kefauver Committee. The West Coast has done fairly well in furnishing material for investigations, but not on such a resplendent scale. A large per cent of the St. Petersburg residents, especially the winter residents, are retired tradesmen and small business men and they are not interested in risking their carefully hoarded and hard earned savings on any horse. Therefore, as might be expected, St. Petersburg has the greatest shuffle-board court on earth. Likewise, the West Coast has tremendous trailer parks but lacks the staggering number of highly expensive hotels which are characteristic of the Miami area.

In the matter of voting, the thinly populated regions are the most conservative, but at times they are puzzled as to how to express this conservatism. When Al Smith was a candidate for president, the question arose as to whether one should be conservative by sticking to the good old Southern Democratic Party

or stand up and protect the good old Protestant Church. Much the same type of choice was presented in the 1952 election, and some interesting decisions were made, but in ordinary cases it may be predicted fairly well how the different sections will vote. For example, in 1948 Dan McCarty was ahead on Wednesday morning, but even then it was realized by many that when the returns came in from the little, isolated precincts in West Florida, Fuller Warren would go ahead.

It is well known that each part of the country has its typical crimes. In the northeast, embezzlement is typical, in the west it is bank robbery, and in the South it is murder or manslaughter. While homicide is common in the South generally, it was Jacksonville which for some years led the world in its murder rate, with Tampa a fairly close second. It is said that Jacksonville lost its preeminence because when a man killed his wife and committed suicide or vice versa, Jacksonville reported the suicide only and assumed that the murder did not count.

The great wealth of West Palm Beach is accompanied by certain practices and attitudes suggestive of Bar Harbor. For example, while the bathing costume on most of the Florida beaches was only slightly more elaborate than that of the Australian aborigines, none of that was allowed at West Palm Beach until relatively recently. The bathing beauties there even had to wear stockings. It was in West Palm Beach that one lady had an expensive pipe organ installed, and soon a second lady placed an order with the organ builder and said, "Now I do not know anything about pipe organs; all I want is for you to put in one which will cost more than the other lady's." This attitude grew in the social soil of that locality.

One cannot fail to see the effects of the different types of culture in anything which happens. At our last gubernatorial inauguration, Miami put on the most scintillating show of all. Their highly trained motorcycle police, their floats, and their other features surpassed everything else. By contrast, Jacksonville's participation was not overly impressive. All this was just a part of the general picture. Miami is not an industrial city; it lives by furnishing entertainment. We may say that all it has to sell is a big show. But Jacksonville is commercial and industrial and pays relatively little attention to excessive exhibitionism.

Let us turn from Florida momentarily and look to Colorado. Some decades ago Creede was a little town in the midst of exquisite scenery, but it had not been exploited as a tourist center and very few people went there. It had extensive mining activity and got its living that way. The people were friendly and hospitable to a remarkable degree. By contrast, Palmer Lake lived off of tourists and there had developed the practice of gouging them whenever possible. It even cost a quarter to get a traveller's check cashed. It must be acknowledged sadly that Florida generally and parts of it especially have been going headlong in the Palmer Lake direction of late and apparently the trend will continue.

It would take many pages and many hours to search out and give the explanations of why St. Augustine's road signs say "bends" rather than "curves", why and what the Latin influence is in Tampa, similarly the significance of the Greek colony at Tarpon Springs, the Czech colony at Masaryktown, the influence of the Ringling Circus and Art Gallery at Sarasota, the characteristic social phenomena of celery raising at Sanford, potato raising at Hastings, the cattle industry at Kissimmee, and the many other specialized activities of Florida's people.

They may all be reduced to the universal human desires for security, new experience, recognition, and response, as conditioned by physical environment, biological factors, population density and diversity, culture, and social control, and taking expression in the social processes of competition, cooperation, adjustment, and other phases of interaction—the influences which one or more persons may exert on one or more others.

CRIME AND SOCIAL RESEARCH

CLYDE B. VEDDER

University of Florida

Although crime is one of the most widely recognized social problems of our time, the efforts of social research in this area are almost entirely without significance. A defensible subtitle of this paper could well be "The Futility of Social Research in the Area of Crime."

A widely accepted definition of crime relates to a violation of a law. The more laws, the more chances of law violation. Any analysis of crime should begin with some consideration of jurisprudence, violation of which produces crime. Legislature, who represent the public, pass too many laws, many of them punitive, many passed in an emotional frenzy. Since 1900, more than 400,000 new laws have been added. There are more than one billion laws on our statute books. We have more laws than people, about six for every man, woman, and child, and our laws are increasing faster than our birth rate. In 1931, 76 per cent of the inmates of Federal Prisons would not have been incarcerated had they committed their crime but fifteen years sooner. (Barnes and Teeters, 1951, p. 77).

Lawmakers are not necessarily well informed, even in the law. One legislator stood up and said, "for this crime of arson, either hang him or make him marry the girl," and in 1950 a state attorney general ruled that "anyone who commits statutory rape in a parked automobile should have his driver's license revoked." (*Time*, 1950). The New York legislature once passed a bill, fortunately vetoed, that required barbers to be licensed, which would bar ex-convicts from this trade, despite the fact that convicts were taught the barbering trade in New York prisons.

To appreciate why the fruits of social research are largely ignored, a general understanding of present-day attitudes of the public toward penal problems is essential.

In the beginning society's attitude towards crime was such that it was considered an affront to the gods. After the rise of the State, crime was regarded as a violation and a challenge to law

and order. Combination of legalistic and religious attitudes persist to the present day and many still think of the criminal as not only a law violator, but a sinner as well.

As Cuber and Harper (1951, p. 1) point out, in many "problem" aspects of everyday life, we follow the dictates of expert rather than public opinion. If the physician diagnoses the patient's "problem" as diabetes the patient accepts this "expert opinion" without insisting on a public-opinion poll in regard to the matter.

In the trouble areas of our society generally labeled "social problems" of which crime is one, we have no such popularly approved experts. For problems relating to race relations, juvenile delinquency, and crime, *who* are to be regarded as "experts" with public recognition comparable to the acceptance that is accorded physicians, engineers, physicists, and chemists? "Expert opinion" rests ultimately upon public acceptance of the "expert." And society fails fully and consistently to accept "experts" on societal phenomena. Society simply does not hear our voices in regard to crime or the treatment of criminals.

There is considerable justification for lack of public acceptance. Social scientists are not in complete agreement and as they communicate with one another use an intellectual jargon which the public does not understand. Such contributors seem more interested in impressing each other than in making information meaningful to all. As a result of this stricture in the communicative processes, society utilizes about ten per cent of our sociological knowledge. It is little wonder that social scientists sometimes get discouraged over the slowness of the public to accept their findings, but some progress is being made in the field of mental illness and its treatment. (Woodward, 1951, p. 443).

There is a continual stream of misinformation stemming from the radio, press, television, and the motion pictures. Much public thought is in terms of stereotypes which are continually reinforced by newspaper cartoons and movies. For example, the public has uncritically accepted Lombroso's earlier conception of the criminal type with the receding forehead, prognathous jaw, dangling arms below the knees and possessing low sensitivity to pain. Many believe that unusual physical characteristics mark the socially variant individual. Do not movies and the theater put before our eyes individuals who are at first glance recognizable as villains?

Contrariwise, the public believes a "good" appearance suggests innocence. Blue eyes, mild manners, a clear complexion, and sun tan tend to remove suspicion. Women, more than men, appear before the jury in the deceptive attire of innocence.

Motion pictures probably deserve the greatest criticisms in furthering these fallacies of human behavior. The American Prison Association is on record in a protest against much of the content of the movie "Caged" as well as an article appearing in Collier's on the same subject. (Cass, 1950, p. 24).

The picture, "Highway 301" comes under similar indictment. Ostensibly recommended by governors of three states, in addition to the F.B.I., at least by strong implication, this movie purports to establish the thesis that there is such a thing as the "congenital criminal." The public is apt to accept this fallacy despite the fact that no one is born a criminal. Crime is social, not biological, hence cannot be hereditary. A criminal does not produce "tainted" offspring. If crime is a matter of "bad blood" we had better prepare for a real crime wave when our Service men return. Inmates of prisons have contributed more than their share to national blood banks.

After writing four letters to the studio responsible for "Highway 301," persistence "paid off" and the writer was referred to the technical director who was asked for some authority, any authority, for the term "congenital criminal." The following letter was received:

"In answer to your letter of October 29, 1951, we used the term "congenital criminal" in our picture "Highway 301" to denote the type of individual who has criminal tendencies from the time of birth.

Practically all the criminals involved in the Tri-State Gang started their criminal careers at the ages of six and seven. This was not due to environmental conditions, inasmuch as their brothers and sisters became law-abiding citizens. These tendencies were due to a congenital, inborn mental condition. These men were beyond reformation or reasoning.

Some people are born with a natural instinct for sexual perversion . . . while others have a congenitally criminal mind which governs their vicious lives.

Sincerely yours,"

This letter is completely devoid of documentation, despite the fact that documentation was requested. Another follow-up letter

was mailed, with self-addressed, stamped return envelope enclosed, but nothing more has been heard.

Social scientists may reach 10,000 students with established scientific fact, but the motion picture may easily reach ten million individuals, including some of the students. Until some control or censorship based on scientific truth is utilized, the public will continue to think of criminals as "sneaky, hand-in-pocket petty thieves, glassy-eyed sex degenerates, fast-talking oily individuals, or the side-mouth talking, black-jack toting hoodlum, who would just as soon knock his grandmother in the head as he would to take a pull on the bottle sticking out of his back pocket." And worst of all, the public is informed that he is "born that way."

Newspapers have promoted crime by constant advertising of crime, by glorifying criminal leaders and acting as press agents for them, by the jocular method of presenting crime news which takes away the dignity of the court proceedings. A reporter applied the name "Purple Gang" to a relatively unimportant group in Detroit and those gangsters were built up by the label into criminal giants. (Sutherland, 1947, p. 184). Due to the apathy of the press, the people of the United States know more about living conditions behind the Iron Curtain than they do of the 200,000 inmates behind prison walls. Despite the fact that the disciplines of Psychology, Psychiatry, and Sociology in every university stress that emphasis must be placed on the individual, rather than on the crime committed, a leading newspaper in one of Florida's largest cities a few weeks ago editorialized: "COURTS ARE TOO MERCIFUL: LET THE PUNISHMENT FIT THE CRIME!" which is just about the way Beccaria phrased it in 1775. Is it any wonder that the public accepts only ten per cent of our sociological knowledge on crime and juvenile delinquency?

Although research in the social sciences indicates an extension of parole and probation, and abolition of capital punishment, most of the press and the public are against the former and in favor of the latter, despite all evidence to the contrary.

There is great public indifference and ignorance to all rehabilitative efforts plus the fear that such plans might cost too much. The public still has its twin convictions that crime must be punished and criminal behavior must repeat itself, since criminals are born bad. Unfortunately, jealousies, pride, "ethnocentrism"

prevent the educators, psychiatrists, psychologists, and sociologists from pooling their knowledge in an honest effort to make crime prevention and rehabilitation a real and living thing.

There has been little or no reform in American jurisprudence the past 100 years. Courts produce injustice as well as justice, are not business-like, utilize little scientific knowledge, and have operated as closed disciplines since Beccaria's time. In 1909, Taft said, "the administration of criminal law is a disgrace to our civilization." (Sutherland, 1947, p. 277).

Our courts still use medieval devices. Only this spring, a Charleston, South Carolina defendant was brought into court and ordered to balance a Bible between her fingertips and that of her jailor's. Then the judge intoned these words:

"By Saint Peter, by Saint Paul
By the grace of God who made us all,
If this woman took the money,
Let the Bible fall."

The Bible wavered and fell and the defendant confessed, revealed the missing \$200 in her house, and was hustled off to jail. (*Time*, 1951).

This lack of "scientific approach" was further exemplified by a prosecuting attorney of St. Louis in the fall of 1950. He offered two Negroes a two year sentence if they would plead guilty to robbing another Negro of \$79, but when they pleaded innocent, he managed to convict them and got them a twenty year sentence for fighting the case, and this heavier sentence was affirmed by the Missouri Supreme Court. As James Finan (1951) from the Editorial Staff of *Reader's Digest*, said in his address to the American Prison Association of that year, "when you ladies and gentlemen can explain *that* to yourselves, perhaps you can explain it to me."

Serology, the science of blood testing, is not accepted by many courts. The California case of *Arias v. Kalensnikoff* (1937), in which the defendant was found guilty, although exonerated by the test, and despite evidence that (1) the mother was twice married, (2) she named another man on certificate first, (3) the accused was over 70 years of age and said by his wife to have been impotent for many years. But the jury took the mother's word, and ignored the scientific evidence, and another jury did the same in the case of Charlie Chaplin.

The conflicting view of modern science and legal procedure was again illustrated according to the Christian Men's League in Pennsylvania. Despite the medical view that alcoholism is a disease, the Pennsylvania court decided that alcoholism is a self-inflicted injury and delivered itself of the following fallacy: "Man drinks because he desires, intends, and *wills* to experience the effect. If the sane man chooses to use the destructive forces upon himself, the law will not relieve him from his folly." (*Spectator*, 1951).

Such decisions, for the most part go unchallenged by both the physical and social sciences. Suggestions are in order.

What is needed is official agitation for a change, and we can commence by scrapping Beccaria's penal philosophy of the 18th century and concentrate upon the "doer" instead of the "deed." Attempts should be made to educate the public through an enlightened press, because most people only know "what they read in the papers."

Distinctions between misdemeanors and felonies should be abolished, as well as thousands of silly, senseless and stupid laws as failure to attend church for three successive times is a capital offense in one state. Incentives should be provided ex-convicts by a definite plan of "social forgiveness" such as the elimination of criminal records after a ten year successful adjustment. Those who are interested in the control of crime can find more justification for approaching their problem in the *local* community than on a national scale. We should place a ceiling on maximum sentences, similar to Mexico's 30 year limit, abolish capital punishment in states without large racial minorities, and provide legal assistance to all accused of crime. At the moment, 90 per cent of those incarcerated forfeit their constitutional right to a trial and "cop out" to a lesser charge.

One of the most vital needs of the times is a Bureau of Statistics and Research. In the 1951 Annual Meeting of the Mississippi Association on Crime and Delinquency, that organization made this startling challenge:

"The Mississippi Association on Crime and Delinquency will give \$50 in cash to any person at this meeting who can tell how many adult misdemeanor and felony prisoners passed through our county and circuit courts last year. And \$100 will go to the

person who can give the number of adults offenders handled by our municipal and justices of the peace courts last year."

Needless to say, there were no takers. There is no way at present of knowing even the number of arrests and convictions in any state, or in the nation as a whole, much less the characteristics of the offenders, nature of that offense, or their distribution within state or nation.

There should be enacted an absolute Indeterminate Sentence Law. Progressive penology calls for such enactment. All criminals should have sentences from 0 to Life and be committed to a Correction Authority that decides upon the nature and length of treatment, after a careful examination and periodic re-examination.

Abandon the arbitrary, flat sentences, for under the flat sentence, some men are kept too long, others not long enough. This irrational procedure creates more crime, increases cost of crime in apprehending, trying, and rehandling law violators. Stop building maximum-security prisons; only 20 per cent need them.

Dr. Schnur of the University of Mississippi recommends more emphasis on State Police, record and finger-print all violators, including juveniles who are most likely to be professional criminals. State Jail Inspection Service is needed, also State Misdemeanant Farms set up. Every prison needs a reception center as well as a classification program. And finally, some State exchange of prisoners, even consideration of a regional prison, where specialized programs are indicated. New England states are in the lead in this area, just as states are now contemplating the establishment of regional universities.

It is admitted that the above suggestions merely "scratch the surface" as regards solving the crime problem, but at least a much-needed start would be made. The voices of our social sciences have been silent long enough.

REFERENCES

- BARNES, HARRY E., and NEGLEY K. TEETERS
1951. *New Horizons in Criminology*. Prentice-Hall, New York.
- CASS, E. R.
1950. Letters. *Prison World*, (July-Aug.): 24.

CUBER, JOHN F., and ROBERT A. HARPER

1948. *Problems of American Society*. Henry Holt & Company, New York.

FINAN, JAMES

1951. There is No Prison Problem. *Federal Probation*, (Mar.): 18.

SOUTHERN MICHIGAN STATE PRISON

1951. *The Spectator*, (Jan. 20).

SUTHERLAND, E. H.

1947. *Principles of Criminology*. J. B. Lippincott Co., Philadelphia.

TIME, INC.

1950. *Time*, (Dec. 4): 27.

1951. *Time*, (Mar. 5): 24.

WOODWARD, JULIAN C.

1951. Changing Ideas on Mental Illness and Its Treatment. *American Sociological Review*, (Aug.): 443.

Quart. Journ. Fla. Acad. Sci., 17(1), 1954.

The papers presented at the Social Sciences Session of the Academy at Rollins College in 1953 have been published as a Symposium Number of *The Florida Anthropologist* (Vol. VI, No. 4) on the subject: "Development of High Civilizations in Hot Climates". Copies may be secured from Ripley P. Bullen, Treasurer, Florida Anthropological Society, 103 Seagle Building, Gainesville, Florida.

SOME METHODS FOR THE TREATMENT OF PROBLEMS IN DIMENSIONAL GEOMETRY

HOWARD D. ALLEN
Lakeland, Florida

Table I lists some of the characteristics of a series of geometrical figures possessing consecutively greater and greater dimensions. Starting, with a dimensionless point, it includes, in order, a line segment of length a , a square of sides a , a cube of sides a and a four-dimensional counterpart of a cube, having sides of length a .

The method used in drawing the different axes of a set of four-dimensional coordinates is shown in figure 1.

Consider first the origin o . This is a point the sole characteristic of which is position. It is also the first of the series of figures listed in Table I.

TABLE I

Characteristics of Figures in Increasing Number of Dimensions. (Column 5 Lists Both Space and Non-Space Characteristics).

Figure	Point	Line	Square	Cube	Four-Dimensional Figure
Number of dimensions	0	1	2	3	4
Terminal points -----	1	2	4	8	16
Line segments -----	0	1	4	12	32
Faces -----	0	0	1	6	24
Cubes -----	0	0	0	1	8
Mutually-perpendicular segments	0	1	2	3	4

The second figure is a line segment of length a . It is the locus traced by a point moving the distance a along the x -axis from the origin. Table I shows the line segment as having one dimension, no faces, no cubes and as having two terminal points each of which is located on the same edge.

The next figure, the square, is the area locus generated by the movement of the previous line-segment, oa , through the distance a along the y -axis from the origin in the xy plane. From the table we learn that it has two dimensions, four terminal points, four edges, one face, no cubes and that it has two perpendicular lines connected at each terminal point.

In the tracing of the square from the generatrix (line segment) there is a line segment in the locus for the initial and final positions of the generatrix and an additional line segment traced by each moving terminal point—four line segments in all.

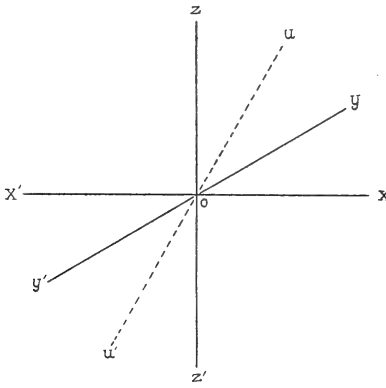

Fig. 1

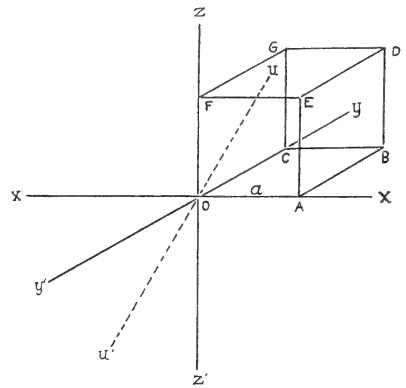

Fig. 2

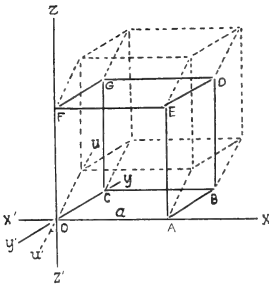

Fig. 3

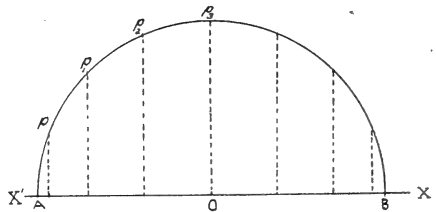

Fig. 4

Fig. 1. One method of combining non-space (u) with space coordinates. Figs. 2-3. Successive steps in the construction of space non-space figure. 2, line OA (generatrix point O), square $OABC$ (generatrix line OA), cube $OABCGDEF$ (generatrix square $OABC$); 3, space and non-space perspective figure traced by generative cube $OABCGDEF$ moving along u -axis. Fig. 4. Resolution by projection of x -component of circumferential distances.

Illustrated in figure 2 is the cube OABCGDEF the generatrix of which is OABC, the square section of the xy plane. At each position along its path from the origin through the distance a along the z -axis the generatrix remains coincident with or parallel to the xy plane.

This figure has three dimensions, eight terminal points, and six faces (the initial face, the final face and one face generated by the movement of each line segment). It has twelve line segments, four initial, four final, and one generated by the movement of each terminal point. There are three mutually perpendicular lines joined at each terminal point. Appearing for the first time is the cube of which there is one.

If the cube is moved as generatrix for the distance a along the u -axis from the origin, the locus is the four-dimensional member of the series of figures in Table I.

Besides the terminal points, line segments, faces and cubes of the initial and final positions of the generatrix cube, there is an additional line segment traced by each moving terminal point, a face traced by each moving line segment and a cube traced by each moving face.

The figure (illustrated in figure 3) possess four dimensions, sixteen terminal points, thirty-two line segments, a total of twenty-four faces, eight cubes, and four mutually perpendicular lines joined at each terminal point. This is, of course, not possible in three dimensions but requires a fourth, which we can scarcely perceive.

It is to be noted that the line segment is bounded by two points, the square by four line segments, the cube by six squares and the four-dimensional figure by eight cubes.

The proof of the theorem, if it were presented as a theorem, would be in the form of geometrical induction, i.e., if so and so is true for such and such a value of n and for the next greater value of n and for the next, then it must also be true for the next greater value of n , et cetera, (n in this case being the number of coordinates required for the construction of the figure).

Continua and Projections.
Continua of the form

$$x^2 + y^2 + \dots = r^2 \quad (\text{I}),$$

furnish another means of examining figure series in dimensional geometry through the examination of their geometrical forms so far as is possible. Of especial interest are the projections of this series of figures on a point, line segment, plane, or volume as the case may be. Intercepts, too, are of value because they lend themselves readily to algebraic proof merely by setting the proper variable equal to zero.

Starting with the pair of isolated points

$$x^2 = r^2 \quad (\text{II})$$

and constructing the figure, it is seen that the first of this series is discontinuous. More exactly it may be said to be continuous through n dimensions where n is the number of dimensions of the figure—in this case zero. II represents the intercepts of the circle

$$x^2 + y^2 = r^2 \quad (\text{III})$$

on the x -axis.

III is a continuum of one dimension. Its semi-projection on the x -axis (Fig. 4) is a line segment. Points p_1, p_2, p_3, \dots spaced evenly along the semi-circumference, when projected on the diameter, AB, display an harmonic relationship in their distances from the origin. Distances between any two adjacent projected points are foreshortened along the x -axis in both directions away from the origin. Because only the x component of the distances between adjacent points shows up on the projection, the points on the projection appear to be concentrated towards the right and left extremities of the diameter.

The circle, III, is the intercept of the quadric surface

$$x^2 + y^2 + z^2 = r^2 \quad (\text{IV})$$

on the xy -plane.

Strictly speaking the equation immediately above does not represent a two-dimensional figure. It is a continuum and motion in a very small section of the curvo-planar surface is practically limited to two dimensions. Its projection on the xy -plane is the area enclosed within the circle

$$x^2 + y^2 = r^2.$$

Points evenly distributed over one-half of the quadric surface (IV) show the same relationship as to distance between adjacent

points and crowding toward the periphery as do those of the semi-circle, when projected on the disc section of the xy -plane. The chief difference is that one more dimension is involved and, in this second case, foreshortening and crowding away from the origin are in all directions in the xy -plane.

All of this suggests that the equation

$$x^2 + y^2 + z^2 + u^2 = r^2 \quad (V)$$

is that of a three-dimensional continuum whose u -intercept is the quadric spherical surface (IV) and that evenly spaced points throughout the continuum, would, when projected on the volume inclosed within the u -intercept, display the same harmonic foreshortening and crowding but in all directions in three dimensions away from the origin.

Enough of the series of figures is known to permit verification, extension and proof through geometrical induction, although it is not possible to extend this proof by ordinary known means.

One conclusion is that the entire visible universe, so far as it is known, looks something like this hypothetical projection of a three-dimensional continuum on ordinary space. Circumferential distances should be unaffected in the projection. This is apparently true in the universe. Radial distances should be foreshortened (as in perspective) away from the origin. The only radial distances measurable beyond the range of ordinary triangulation are those between successive wave fronts of radially incident light. The radial distances between these wave fronts appear foreshortened in the manner of perspective away from the observer.

Great crowding of galaxies toward the visible periphery of ordinary space is another phenomenon which occurs in the universe. The hypothetical projection of a three-dimensional continuum calls for this crowding, toward the u -intercept, of points or bodies distributed more or less homogeneously throughout.

One great objection to the similarity seems over-ruled when we consider the source of light near at hand as being on the periphery of another projection perpendicular to the plane of observation along the u -axis. To explain this more clearly it is necessary to cite the projection of a quadric surface on a diametrical plane. If, from our point of observation, this quadric surface is entirely

a plane projection and we wish to consider the right or left or top or bottom hemispheres we must look upon them as discs viewed edgewise. True distances measured on the quadric surface would, in the case of the projection of any of the above hemispheres, appear less near at hand (the periphery of the disc) and forelengthened toward its center.

This phenomenon would be the result of trying to picture the quadric surface as a truly two-dimensioned figure. Extending this one more dimension, if the three-dimensional continuum is viewed as purely three-dimensional—not curved through a fourth—both the *source* and the *destination* of the moving yardstick must be considered if any comparison of relative distances is to be made.

LITERATURE CITED

BRINK, RAYMOND W.

1937. *A First Year of College Mathematics*. D. Appleton-Century Co. New York. pp. 573-580.

HAUSMANN, ERICH, and SLACK, EDGAR P.

1948. *Physics*. D. Van Nostrand Company, Inc. Toronto. pp. 23-33, pp. 101-170.

SMITH, EDWARD S., SALKOVER, MEYER, and JUSTICE, HOWARD K.

1938. *Calculus*. John Wiley & Sons, Inc. New York. pp. 169-171, pp. 195-ff, pp. 475-ff.

THE MULTITRICHOMATE OSCILLATORIACEAE
OF FLORIDA¹

C. S. NIELSEN
Florida State University

Species of the Oscillatoriaceae may be divided into two groups. One of these is distinguished by the development of from two to many trichomes within the sheath, and the formation of colored sheaths in many species. In the other only one trichome is present in a sheath and a yellow to dark sheath may rarely be produced, but never red nor blue. Of these latter, three genera, characterized by the absence of a visible sheath, *Oscillatoria*, *Spirulina*, and *Arthrospira*, have been treated in a previous paper (Nielsen, 1954); the remaining will be discussed in a subsequent consideration.

Five of the six genera of the multitrichomate forms as listed by Gomont (1892) are represented in the Florida flora, *Dasygloea* excepted. The collections include those of J. Donnell Smith in the years 1878-1880 in the Gainesville area which are described in the papers of Rev. Francis Wolle. The specimens in the Wolle herbarium have been reexamined by Drouet (1939). These re-determinations of the Florida specimens as originally reported by Wolle (1887) and Tilden (1910) are cited. The invaluable assistance of Dr. Francis Drouet of the Chicago Natural History Museum for the determination of all specimens cited is most gratefully acknowledged.

The following abbreviations are used to designate the location of these collections: C, cryptogamic herbarium of the Chicago Natural History Museum; D, personal herbarium of Francis Drouet; F, herbarium of the Florida State University; H, Farlowe herbarium, Harvard University; N, United States National Herbarium, Washington, D. C.; N. Y., Herbarium of New York Botanical Garden; P, University of Pennsylvania herbarium; and U, herbarium of the University of Florida.

KEY TO GENERA

Section I.—Trichomes never exceedingly numerous in sheath, more or less loosely aggregated. Sheaths colored in many species.

¹ Contribution number 61, Botanical Laboratory, Florida State University.

- A Sheaths firm, lamellose, hyaline or colored. Many trichomes within sheath; cells never very short, apex of trichome never capitate. 1. *Schizothrix*
- AA Sheaths firm, lamellose, purple or peach-colored. Trichomes 1-few within sheath. Apex of trichome never capitate. 2. *Porphyrosiphon*
- AAA Sheaths more or less mucous, occasionally becoming diffuent with age, always hyaline. Many trichomes within sheath; cells never longer than wide, in several species exceedingly short; apex of trichome capitate. 3. *Hydrocoleum*

Section II.—Numerous trichomes in the filaments developing within sheath, closely congested. Sheaths always hyaline, never lamellose.

- A Filaments caespitose, dichotomously branched. Sheaths firm or hardly diffuent. 4. *Sirocoleum*
- AA Filaments repent, here and there branching or simple. Sheaths more or less mucous, often diffuent. 5. *Microcoleus*

1. *Schizothrix* Kützing ex Gomont.

Filaments forming a definite cushion, often calcium-encrusted, or in erect, prostrate or waving fascicles, or entwined in a pan-nose stratum, often trunk-like below, above spreading, rarely sparingly pseudo-branched and simple. Sheath hyaline, or becoming dark yellow or red or purple or blue, firm, lamellose, acuminate apices, and turning blue with chlor-zinc-iodine in nearly all species. Trichomes few within sheath, more or less loosely aggregated; cell length often longer than trichome diameter, never shorter by much; apex of trichome straight, usually attenuate, never capitate. Membrane of apical cell not thickened above.

Subgenus I. Inactis.

Filaments caespitose, often with repeated pseudo-branches, forming pulvinate finally often lime-encrusted conrescences, or penicillate waving fascicles. Sheaths hyaline or scarcely colored.

A. Filaments pulvinate caespitose.

1. Filaments bare at base, above falsely branched. Trichomes 2-3 μ wide; cells shorter than diameter.

1. *S. vaginata*

2. Filaments densely intricate and tortuous below, more or less free above. Trichomes 1.5-3.0 μ wide; cells up to three times longer than diameter.

2. *S. aikenensis*B. Filaments penicillate, in waving fascicles. Trichomes torulose, 5-11 μ wide.3. *S. rivularis*

Subgenus II. Hypheothrix.

Filaments prostrate, often sparingly pseudo-branched, closely intricate in a stratum sometimes calcium-encrusted. Sheaths hyaline.

- A. Filaments exceedingly contorted, scarcely flexuous, not extricated without rupturing. Stratum thin, leathery-membranaceous, never lime-encrusted. Sheaths firm. Trichomes within sheath in pairs or solitary, 1-1.7 μ wide.

4. *S. calcicola*

B. Filaments long and flexuous, extricated without rupturing.

1. Filaments most delicate, exceedingly elongate, scarcely branched.

- a. Stratum lime-encrusted. Trichomes 1-1.7 μ wide; cells longer than diameter.

5. *S. coriacea*

- b. Stratum not lime-encrusted. Trichomes 1.5-2 μ wide; cells longer than diameter.

6. *S. lardacea*

2. Filaments moderately elongate, not delicate, branched.

- a. Trichomes 1.5-3 μ wide; cells longer than diameter, up to 5 μ long.

7. *S. arenaria*

- b. Trichomes 1.7-2 μ wide; cells longer than diameter, 8-12.5 μ long. Not lime-encrusted.

8. *S. longiarticulata*

Subgenus III. Symplocastrum.

Filaments prostrate at base, closely joined above into erect symplocoid fascicles. Sheaths hyaline.

- A. Rigid, erect, spine-like fascicles, 3 cm. or more in height. Trichomes 3-6 μ wide, 4-11 μ long. Protoplasm coarsely granular. 9. *S. Friesii*
- B. Filaments prostrate to somewhat, erect, and at times slightly fasciculate. Trichomes 3.3-3.6 μ wide, length 2-2½ times width. Protoplasm homogeneous to finely granular. 10. *S. mellea*
- C. Filaments long, erect, intricate below, often in short contorted erect fascicles above. Trichomes 4-6 μ wide; cells quadrate or shorter than wide. Apical cell with depressed conical calyptra. 11. *S. Stricklandii*

Subgenus IV. Chromosiphon.

Filaments forming erect or prostrate symplocoid fascicles, or a pannose stratum, rarely free-floating. Sheaths always developing color with age.

- A. Cells subquadrate, or shorter than diameter.
1. Sheaths blue toward inside. Trichomes 7.5-8.5 μ wide. 12. *S. chalybea*
 2. Stratum, caespitose or appressed, semiorbicular. Sheaths reddish. Trichomes may be solitary within sheath, 4-9 μ wide. Apical cell scarcely attenuate, rotund. 13. *S. thelephoroides*
 3. Stratum indefinite. Sheaths purple-gold or peach-color. Trichomes numerous within sheath, 6-8 μ wide. Apical cell conical, often acute. 14. *S. purpurascens*
 4. Stratum never caespitose. Sheaths yellowish-gold. Trichomes scarcely constricted at cross-walls, 7-13 μ wide; cells subquadrate to twice as short as diameter. 15. *S. Muelleri*
 5. Stratum black, cartilaginous. Sheaths dark blue. Trichomes constricted at cross-walls, 4-7 μ wide. Apical cell at first shortly conical, with age becoming longer and most acutely conical. 16. *S. Taylorii*
- B. Cells longer than wide.
1. Filaments moderately elongate. Sheaths yellow-gold. Trichomes 3-4 μ wide. Cells rarely subquadrate. 17. *S. Lamyi*

2. Filaments moderately elongate. Sheaths blue-green to blue, irregular at margins. Trichomes 1.7-3 μ wide.

18. *S. Heufleri*

3. Filaments slender, tortuous. Sheaths rose to dark red, eroded. Trichomes 1-2.5 μ wide. Apical cell rotund.

19. *S. roseola*

4. Filaments elongate. Sheaths internally pale to steel-blue, eroded at margins. Trichomes 2-4 μ wide. Apical cell long and acute conical.

20. *S. Guiseppi*

5. Filaments elongate. Sheaths dark violet, eroded at margins. Trichomes 2.0-2.5 μ wide. Apical cell obtuse conical.

21. *S. violacea*

1. *Schizothrix vaginata* Gomont. Monogr. Oscill. p. 302, pl. 7, f. 1-4 (1892).

Stratum expanded, crusty-mamillose, calcium-encrusted, dark bluish-grey, fragile, or not hardened by lime, greenish-black, very hard in dried specimens. Filaments densely matted in specimens not lime-encrusted, forming a horny mass, erect, parallel or tortuous and intricate, simple bases, apices sparingly pseudo-branched. Sheaths wide, somewhat lamellose, apices acuminate, rarely ocreate, turning blue with chlor-zinc-iodine. Trichomes pale blue-green, few within sheath or solitary, not constricted at cross-walls, 2-3 μ wide; cells often shorter than diameter of trichome, occasionally subquadrate, 1-2 μ long; cross-walls granular.

Lee county: salt flats, region of Hendry creek, about 10 miles south of Fort Meyers, *Paul C. Standley* 73208, 73257, 73274, 11-25 Mar. 1940 (C). Wakulla county: salt flats, north of lighthouse. St. Marks Wildlife Refuge, *Nielsen* 10, 4 Oct. 1951 (C, F).

The species may be found with *Calothrix scopulorum*: B. & F.

2. *Schizothrix aikenensis* (Wolle ex Forti) Philson. Journ. Elisha Mitchell Sci. Soc. 55: 96 (1939).

Stratum expansum, tenue, calce haud incrustatum, aeruginosum vel olivaceum vel fusco-griseum atrum. Fila inferne dense intricata tortuosa, superne plus minusve libera. Vaginae firmas, ambitu leviter erosae, hyalinae, chlorozincico iodurato non coerulescentes, trichomata pauca plerumque solitaria includentes. Trichomata dilute aeruginea, 1,5 ad 3,0 μ crassa, ad genicula non valde constricta; articuli diametro ad triplo longiores, protoplasmate grosse granuloso farcti; cellula apicalis obtusa conica.

Stratum expanded, thin, not calcium-encrusted, blue-green to olive to dark grayish black. Filaments densely intricate and tortuous below, more

or less free above. Sheaths firm, slightly eroded at margins, hyaline, not turning blue with chlor-zinc-iodine reagent, with few trichomes enclosed, usually solitary. Trichomes pale blue-green, 1.5-3.0 μ in diameter, not conspicuously constricted at cross-walls; cells up to three times diameter, protoplasmic granules conspicuous; apical cell obtuse conical.

South Carolina. Aiken, in sluggish pools, *H. W. Ravenel* 243, 1877 (C), type material of *Hypheothrix aikenensis* Wolle. Florida: Holmes county, bank soil of Choctawhatchee river, 5 miles north of Westville, *H. R. Wilson*, 4 Aug. 1952 (C, F). Wakulla county, Spillway dam, Phillips pool, St. Marks Wildlife Refuge, *Nielsen & Madsen* 518, 9 Oct. 1948 (C, F).

The species has been reported for the state by Crowson (1950).

3. *Schizothrix rivularis* (Wolle) Drouet. Field Mus. Bot. Ser. 20 (6): 131 (1942).

Caespitose, delictae gelatinous fascicles up to 10 cm. tall, above blue-green to violet, below and within discolored, hyaline sheath, above slender, below wide, often entirely diffuent, turning brilliant blue with chlor-zinc-iodine. Trichomes blue-green to rose, fragile, easily breaking, 5-11 μ wide, constricted at cross-walls apices attenuate and conical; cells subquadrate, more or less shorter or longer than diameter, cross-walls not granular, containing large refringent protoplasmic granules; apical cell long and obtuse conical.

Wakulla county: Spillway dam, Phillips lake, St. Marks wildlife refuge, *Nielsen, Madsen & Crowson* 730, 5 Dec. 1948 (C, F); *Madsen, Drouet & Crowson* 810, 14 Jan. 1949 (C, F).

The trichomes averaged 7.5 to 9 μ in diameter, and were found with *Hapalosiphon pumilus* B. & F. Crowson (1950) reported the species for the state.

4. *Schizothrix calcicola* Gomont. Monogr. Oscill. p. 307, pl. 8, f. 1-3 (1892).

Stratum never lime-encrusted, gelatinous, very hard upon drying, thin, papery-membranaceous, black or rarely yellowish blue-green. Filaments short, very tortuously and densely intricate, not extricated without rupturing, rarely pseudo-branched. Sheaths firm, subcartilaginous, apices acuminate, at first firm, cylindrical with one trichome included, getting wider with age, sublamellose, eroded and irregular at margins, trichomes two or rarely more included, not turning blue with chlor-zinc-iodine. Trichomes pale blue-green, not constricted at cross-walls, 1-1.7 μ wide; cells longer than trichome diameter, usually 2-3 μ , occasionally up to 6 μ ; cross-walls at times with two protoplasmic granules.

Citrus county: in pothole, Hernando, *Brannon 44, 219*, 10 Nov. 1940 (C); Dade county: base of avocado tree, 5 miles west of Goulds, *C. R. Jackson 5*, 15 July 1952 (C, F); Jackson county: Florida Caverns State Park, *Nielsen & Madsen 332*, 31 Aug. 1948 (C, F); Leon county: moist limestone cliff, Apalachicola river at Jackson Bluff, *Jackson*, 9 Nov. 1950 (C, F); Wakulla county: spring, Phillips picnic grounds, Newport, *Nielsen, Madsen & Crowson 173*, 14 July 1948 (C, F); on rock in Theb's pool, Newport, *A. H. Johnston 75*, 11 Nov. 1950 (C, F).

The species was found with *Calothrix parietina* B. & F., *Anacystis montana* (Lightf.) Dr. & Daily, and *Fischerella ambigua* (B. & F.) Gom. It has been reported for the state by Nielsen & Madsen (1948 a) and Brannon (1952).

5. *Schizothrix coriacea* Gomont. Monogr. Oscill. p. 309, pl. 8, f. 6-7 (1892).

Stratum lime-encrusted, broadly expanded up to $\frac{1}{2}$ cm. wide, crustaceous-leathery, rugulose, greenish-red, pale rose, or brick-red, below discolored. Filaments very densely intricate, fragile, however, separating without rupturing, exceedingly elongate and flexuous, generally sparingly pseudo-branched. Sheaths cylindrical, firm, close, lightly eroded, long acuminate apices, never lamellose, turning very blue with chlor-zinc-iodine. Trichomes pale blue-green, few within sheath, parallel, or solitary, 1-1.7 μ wide, in dried specimens constricted at cross-walls, cells indistinct. Cells generally much longer than trichome diameter, 3-6 μ long; cross-walls rarely granular; apical cell acute conical.

Dade county: quarry, 16th Ave. & 79th St. N.W., Miami, *Ruth Patrick*, Jan. 1939 (C); floating on water in backwash of canal at eastern edge of cypress swamp on Tamiami trail, *Ruth Patrick 3*, 28 Dec. 1937 (D). Jackson county: on limestone walls, Florida Caverns State Park, *Drouet, Nielsen, Madsen & Crowson 10374*, 4 Jan. 1949 (C, F).

The species was found with *Scytonema Hofmanii* B. & F. and *Plectonema nostocorum* Gom. It has been reported for the state by Madsen & Nielsen (1950).

6. *Schizothrix lardacea* Gomont. Monogr. Oscill. p. 311, pl. 8, f. 8-9 (1892).

Stratum expanded, not calcium-impregnated, up to 3 cm. wide, hard and elastic, composed of layers of more or less the same color, dark or olive-green to red. Filaments flexuous, exceedingly elongate, tortuous, not

or insignificantly branched, extricated without rupturing. Sheaths cylindrical, firm, apices contracted, even acuminate, at first firm and smooth, with age wider and rough, turning very blue with chlor-zinc-iodine. Trichomes few within sheath, frequently solitary, parallel, pale blue-green, 1.5-2 μ wide, not constricted at cross-walls in living specimens, torulose when dried, cells longer than trichome diameter, on occasion subquadrate, usually 2-3 μ long; cross-walls generally characterized by two protoplasmic granules.

Jackson county: on limestone, cave entrance, Florida Caverns State Park, *Drouet, Nielsen, Madsen & Crowson 10400*, 4 Jan. 1949 (C, F). Wakulla county: on log, sulphur spring, 1 mile north of Newport, *Drouet, Crowson & Thornton 11329*, 25 Jan. 1949 (C, F); on concrete, swimming pool, one-half mile north of Newport, *Drouet, Madsen & Thornton 11349, 11370*, 25 Jan. 1949 (C, F).

The alga was found with *Fischerella ambigua* (B. & F.) Gom., *Gloeocystis Grevillei* (Berk.) Dr. & Daily, and *Scytonema figuratum* B. & F. The thalli of these specimens were from olive-green to violet. The species has been reported for the state by Madsen & Nielsen (1950).

7. *Schizothrix arenaria* Gomont. Monogr. Oscill. p. 312, pl. 8, f. 11-12 (1892).

Stratum thin, fragile, blue-green, never calcium-encrusted. Filaments firm, exceedingly flexuous and closely intricate, trunk-shaped below, trunk simple, above divided and pseudo-branched, pseudo-branches exceedingly twisted and intricate. Sheaths firm, eroded at margins, apices acuminate, in lower part of filaments broad and lamellose, turning blue with chlor-zinc-iodine. Trichomes pale blue-green, few in lower portion of filaments, loosely aggregated, parallel, often solitary in pseudo-branches, 1.5-3 μ wide, constricted at cross-walls (in dried specimens); cells longer than wide, to 5 μ long; apical cell acute conical.

Florida: *Smith*, Mar. 1878 (P).

Drouet (1939) reported the species for Florida from the *Wolle* collection. *Brannon* (1952) reported it also from the state, but the Alachua county collections have been redetermined as *Microcoleus paludosus* Gom. and *M. vaginatus* Gom.

8. *Schizothrix longiarticulata* Gardner apud Geitl. Mem. N. Y. Bot. Gard. 7: 50, pl. 10, f. 95 (1927).

Filaments prostrate, 4.5-5.5 μ in diameter, moderately regular and smooth along surface, may be branched toward the ends; 1-2 trichomes in sheath,

1.7-2 μ in diameter, not constricted at cross-walls; cells 8-12.5 μ long, non-granular; apical cell conical; sheath colorless, homogeneous.

Lee county: on moist sand, region of Hendry creek, about 10 miles south of Fort Myers, *Paul C. Standley* 73206, 73485, 11-25 Mar. 1940 (C). Monroe county: south shore of Big Pine key, *M. Alice Cornman*, 4 Mar. 1943 (C); barren soil, shore near Big Pine Inn, Big Pine key, *M. Alice Cornman*, 2 May 1943 (C); Saddle-bunch Keys, 5 miles east of Key West, *Julian A. Steyermark* 63211a, 11 Mar. 1946 (C); saline flats south of Big Pine Inn, Big Pine key, *E. P. Killip* & *J. Francis McBride*, Apr. 1951 (C); thallus deep green, marshy places, stunted buttonwood stand west of artificial lake, Big Pine key, *E. P. Killip* 41909, 9 Feb. 1952 (C); on dark grayish mud, near buttonwood section, toward North Pine bridge, Big Pine key, *E. P. Killip* 41939, 18 Feb. 1952 (C); on dry soil in depression in limestone, pine-palm woods, Big Pine key, *E. P. Killip* 41938, 18 Feb. 1952 (C); on dry gray soil, near buttonwood section toward North Pine bridge, Big Pine key, *E. P. Killip* 41940, 19 Feb. 1952 (C); at Tavernier, *Lawrence B. Isham* 2, 1 Oct. 1952 (C). Palm Beach county: on old cement walks by Royal Poinciana blvd., east of Flagler memorial bridge, Palm Beach *Drouet* & *Louderback* 10216, 24 Dec. 1948 (C). Santa Rosa county: depression in sand dune, Pensacola beach, *Drouet, Nielsen, Madsen, Crowson* & *Pates* 10573, 10587, 10596, 10598, 10609, 8 Jan. 1949 (C, F). Broward county: on barren ground beside the road between Dania beach and Hollywood beach, *Drouet* & *Louderback* 10271, 28 Dec. 1948 (C); in barren spots of a road-embankment in the mangrove swamp south of South lake, Hollywood, *Drouet* 10286, 29 Dec. 1948 (C).

The thallus of these specimens varied from gray to dark green; they were not found on limestone, but formed incrustations in barren spots on soil and sand. They were found with *Lingbya aestuarii* Gom., *Porphyrosiphon fuscus* Gom., *P. Notarisii* Gom., *Scytonema figuratum* B. & F., *S. crustaceum* B. & F., *S. ocellatum* B. & F. and *Schizothrix purpurascens* Gom. The species was reported for the state by Madsen & Nielsen (1950).

9. *Schizothrix Friesii* Gomont. Monogr. Oscill. p. 316, pl. 9, f. 1-2 (1892).

Stratum indefinite, expanded, black or olive to steel-blue. Lower filaments tortuous and intricate, above erect, parallel, subdichotomously and

falsely branched at ends, forming spiny erect rigid fascicles 3 cms. or more high. Sheaths cylindrical, firm, acuminate apices, lamellose, smooth or a little eroded at margins, turning blue with chlor-zinc-iodine. Trichomes pale blue-green, few within sheath or solitary, parallel, conspicuously constricted at cross-walls, 3-6 μ wide; cells quadrate or up to twice the width, 4-11 μ long, all except apical cell filled with large protoplasmic granules; apical cell truncate-conical.

Florida: *Smith*, Mar. 1878 (P). Jackson county: on barren red clay banks, U. S. highway no. 90, 5 miles east of Marianna, *Drouet, Nielsen, Madsen & Crowson 10340*, 4 Jan. 1949 (C, F). Liberty county: Florida highway no. 20, swamp at Ochlockonee river, *Nielsen & Kurz 875*, 19 Feb. 1949 (C, F). Walton county: Florida highway no 81, 5 miles north of Redbay, *Nielsen & Madsen 448*, 3 Sept. 1948 (C, F).

This species was reported for the state by Drouet (1939) and Nielsen & Madsen (1948b).

10. *Schizothrix mellea* Gardner. Mem. N. Y. Bot. Gard. 7: p. 53 (1927).

Filaments prostrate to somewhat erect, and at times slightly fasciculate, 400-800 μ long, 8-15 μ diameter, moderately and alternately branched; apices acuminate, closed; trichomes 1-3, or as many as 6, within a sheath, 3.3-3.6 μ diameter, straight or arcuate, with filaments not congested, slightly constricted at cross-walls; cells 2-2.5 times as long as broad, homogeneous to finely granular, pale aeruginous to slightly honey-color; cross-walls thin, but conspicuous; apical cell blunt-conical; sheath homogeneous, hyaline, but soon changing to dense honey-color.

Schizothrix mellea var *minor* Gardner. Mem. N. Y. Bot. Gard. 7: p. 53 (1927).

Trichomes 2.2-2.4 μ in diameter.

Collier county: on dry sand near Naples, *Paul C. Standley 73382*, 19 Mar. 1940 (C). Lee county: on wet sand, region of Hendry creek, about 10 miles south of Fort Myers, *Standley 73534*, 11-25 Mar. 1940 (C). Washington county: stream bank, Falling Waters, 4 miles south of Chipley, *C. R. Jackson*, 14 Jan. 1951 (C, F).

The thalli of the specimens examined varied from black to dark gray. *Zygonium ericetorum* (Roth.) Kütz. was found with several specimens.

11. *Schizothrix Stricklandii* Drouet. Amer. Midl. Nat. 29: 51 (1943).

Stratum expanded, pannose, from olive to green through black; filaments long erect robust, below intricate, above branching often in contorted short erect fascicles; sheath hyaline at first slender, with age becoming wider and lamellose, eroded at margins, turning brilliant blue with chlor-zinc-iodine; trichomes blue-green to olive, 4-6 μ wide, not or very slightly constricted at cross-walls, apices not or very little attenuate; cells quadrate or shorter than diameter (never longer), cross-walls especially conspicuous, protoplasmic granular; apical cell short and truncate-conical, membrane thickened above and more or less depressed-conical.

Alachua county: Hibiscus Park, Gainesville, *Brannon* 219, 4 Apr. 1944 (C, U); 261, 2 Aug. 1944 (C); 339, 5 June 1946 (C). Gadsden county: barren ground in upland woods, U. S. highway no. 90, 4 miles east of Quincy, *Drouet, Nielsen, Madsen & Crowson* 10424, 4 Jan. 1949 (C, F). Jackson county: at wayside park, U. S. highway no. 90, 1 mile west of Cottondale, *Nielsen & Madsen* 852, 19 Feb. 1949 (C, F). Marion county: Rainbow Springs near Dunnellon, *Brannon* 376, 20 Oct. 1946 (C). Monroe county: on dry compact soil, along upper N-S road about $\frac{1}{4}$ mile north of E-W road, *E. P. Killip* 41772, 17 Jan. 1952 (C). Wakulla county: barren ground, St. Marks river bridge, Newport, *Drouet, Madsen & Crowson* 10796, 10817, 13 Jan. 1949 (C, F).

Plectonema Wollei Gom. and *P. Nostocorum* Gom. were frequently found with these specimens. The species has been reported for the state by Madsen & Nielsen (1950) and Brannon (1952).

12. *Schizothrix chalybea* Gomont. Monogr. Oscill. p. 319, pl. 9, f. 3-5 (1892).

Stratum indefinite, tomentose, pale blue-green to steel blue. Filaments undulate, moderately elongate, pseudo-branched, false branches dichotomous, appressed, joined loosely in erect fascicles two mm. high. Sheaths very wide, lamellose, layers discolored, internal pale steel blue, external hyaline, firm, cylindrical, smooth or a little eroded at the margins, turning blue with chlor-zinc-iodine. Trichomes dark green, few within sheath and parallel, or often solitary, conspicuously constricted at cross-walls, 7.5-8.5 μ wide. Cells generally shorter than diameter of trichome, occasionally subequal, 3-8 μ long, all except apical cell filled with large protoplasmic granules. Apical cell up to 11 μ long, obtuse to acute conical.

Florida: *Smith*, Mar. 1878 (P).

Scytonema crustaceum B. & F. was found with this specimen. Drouet (1937) states that this species appears usually to inhabit moist limestone. He (1939) has reported it for the state.

13. *Schizothrix thelephoroides* Gomont. Monogr. Oscill. p. 319, pl. 10, f. 1-4 (1892).

Stratum pannose, blackish-red, caespitose to appressed, semi-orbicular. Filaments dichotomously divided and pseudo-branched at appressed edges, forming fascicles one-half cm. high, apices acuminate, more or less spirally contorted. Sheaths, firm, very wide, lamellose, layers discolored, internal reddish, external hyaline, below acuminate apex most often dilated, slightly eroded at margins, transversely corrugate, turning blue with chlor-zinc-iodine. Trichomes blue-green, many or solitary within sheath, occasionally two, parallel, separate, conspicuously constricted at cross-walls, 4-9 μ wide; cells in lower portion of trichome consistently twice as long as wide, in upper portion subquadrate, 6-14 μ long, filled with large protoplasmic granules; apical cell scarcely attenuate, rotund.

Lee county: on sand, region of Hendry creek, about 10 miles south of Fort Myers, *Paul C. Standley 73430, 73451, 73465*, 11-25 Mar. 1940 (C).

14. *Schizothrix purpurascens* Gomont. Monogr. Oscill. p. 320, pl. 9, f. 6-8 (1892).

Stratum indefinite, expanded, blackish-violet. Filaments somewhat elongated, more or less divided and pseudo-branched subdichotomously, intricate below, above parallel and forming tortuous creeping fascicles. Sheaths purplish-gold to rose, apices hyaline, firm, solid, very broad and lamellose, irregular and eroded at the margins, apices acuminate, turning blue with chlor-zinc-iodine. Trichomes pale blue-green, numerous within sheath, somewhat separate and parallel, generally constricted at cross-walls, 6-8 μ wide; cell length equivalent to trichome diameter or to one-half width, usually 3-8 μ long, all except apical cell filled with large protoplasmic granules; apical cell conical, often acute.

Var. *purpurascens* (*alpha*). Sheaths purple-gold. Trichomes not constricted at cross-walls.

Var. *cruenta* Gom. Sheaths purplish-rose or peach-color. Trichomes generally constricted at cross-walls.

Florida: *Smith*, Mar. 1878 (C, P, N). Calhoun county: barren soil, state highway no. 20, 3 miles west of Blountstown, *Drouet, Crowson & Livingston 10712, 10714*, 10 Jan. 1949 (C, F). Escambia county: depression in sand dunes, Gulf of Mexico, west of Gulf Beach, *Drouet, Nielsen, Madsen & Crowson 10550*, 8 Jan. 1949 (C, F). Gadsden county: barren soil of upland woods, U. S.

highway no. 90, 4 miles east of Quincy, *Drouet, Nielsen, Madsen & Crowson*, 10412, 10414, 10416, 10417, 10419, 10420, 10425, 10426, 10431, 4 Jan. 1949 (C, F); Apalachicola river flood plain. U. S. highway no. 90 at Chattahoochee, *Nielsen* 1442, 9 July 1949 (C, F). Jackson county: on barren red clay, U. S. highway no. 90, 5 miles east of Marianna, *Drouet, Nielsen, Madsen & Crowson* 10334, 4 Jan. 1949 (C, F). Leon county: clay bank near Ochlockonee river, U. S. highway no. 90, west of Stephenville, *Drouet, Crowson & James Petersen* 10481, 10587, 6 Jan. 1949 (C, F); eroded clay bank, Meridian road between Lake Iamonia and Ochlockonee river, *Drouet, Kurz & Nielsen* 11262, 11268, 24 Jan. 1949 (C, F); barren ground, north-west shore of Lake Iamonia, *Drouet, Kurz & Nielsen* 11279, 11281, 24 Jan. 1949 (C, F); barren ground, open pine woods, Fla. state highway no. 61, 6 miles south of Tallahassee, *Drouet, Madsen & Crowson* 11551, 11553, 11556, 27 Jan. 1949 (C, F); barren ground at Blue Sink, state highway no. 61, 8 miles south of Tallahassee, *Drouet, Nielsen, Madsen, Crowson & Atwood* 11582, 29 Jan. 1949 (C, F). Liberty county: limestone canyon walls, Aspalaga on Apalachicola river, *Nielsen, Madsen & Crowson* 773, 12 Feb. 1949 (C, F). Santa Rosa county: depression in sand dunes, Pensacola beach, *Drouet, Nielsen, Madsen, Crowson & Pates*, 10572, 10574, 10575, 10576, 10589, 10596, 10609, 8 Jan. 1949 (C, F). Wakulla county: Spillway dam, Phillips pool, St. Marks Wildlife Refuge, *Drouet, Madsen & Crowson* 10840, 13 Jan. 1949 (C, F). Washington county: soil along U. S. highway no. 90 at Chipley, *Nielsen & Madsen* 444, 3 Sept. 1948 (F); *Nielsen & Madsen* 861, 19 Feb. 1949 (C, F).

The species has been reported for the state by Drouet (1939); he has redetermined the Smith specimen cited by Wolle as *Phormidium congestum* Rabenh. *S. purpurascens* Gom. has also been reported by Nielsen & Madsen (1948b) and by Crowson (1950). The form is found commonly with other algae; some of these include: *Cylindrospermum* sp., *Microcoleus paludosus* Gom., *M. rupicola* (Tild.) Dr., *Mougeotia* sp., *Plectonema Nostocorum* Gom., *Porphyrosiphon Notarisii* Gom., *Schizothrix Lamyi* Gom., *S. longi-articulata* Gard., *Scytonema figuratum* B. & F., *S. Hofmannii* B. & F., *Stigonema panniforme* B. & F. and *Zygonium ericetorum* (Roth.) Kütz.

15. *Schizothrix Muelleri* Gomont. Monogr. Oscill. p. 321, pl. 10, f. 5-7 (1892).

Filaments in an expanded, indefinite stratum, dark to blackish-green, intricate or forming fixed mossy decumbent fascicles, or free-floating, elongate and somewhat flexuous, divided and pseudo-branched at the ends. Sheaths yellow-gold, firm or partially diffluent, irregular at margins, apices acuminate, turning blue with chlor-zinc-iodine. Trichomes blue-green, few within sheath, occasionally solitary, slightly constricted at cross-walls, 7-13 μ wide; cells one-half trichome diameter or a little longer, usually 4-9 μ , filled with large protoplasmic granules; apical cell obtuse-conical.

Liberty county: Deep Cut creek, Aspalaga, Apalachicola river, *Madsen, Wagner & Pates* 2052, 15 Apr. 1950 (F).

16. *Schizothrix Taylorii* Drouet. Amer. Midl. Nat. 30 (3): 673 (1943).

Filaments among other algae or joined into a black cartilaginous stratum, growing straight, subrigid, subparallel, bases branched, sheath at first thin and hyaline, with age getting wider, dark blue and within black to steel-blue, lamellose, smooth at margins or eroded, turning blue with chlor-zinc-iodine; trichomes pale blue-green, 4-7 μ wide, constricted at cross-walls, frequently torulose, apices attenuate and acuminate; cells quadrate or shorter or longer than diameter, protoplasm inconspicuously granular, cross-walls not granular; apical cell at first shortly conical, with age becoming longer and most acutely conical.

Collier county: dry sand, Marco Island, *Paul C. Standley* 73399, 73401, 73410, 19 Mar. 1940 (C). Monroe county: south shore of Big Pine key, *M. Alice Cornman*, 4 Mar. 1943 (C); Saddlebunch key, 5 miles east of Key West, *Julian A. Steyermark* 63210 a, 11 Mar. 1946 (C); saline flats south of Big Pine Inn, Big Pine key, *E. P. Killip & J. Francis McBride*, Apr. 1951 (C); Cudjoe key, *Lawrence B. Isham* 6, 1952 (C); greenish saline flats near Knight home, Big Pine key, *E. P. Killip* 41819, 24 Jan. 1952 (C); Indian key, *Lawrence B. Isham* 15, 1 Oct. 1952 (C).

The thalli of the specimens examined and cited above varied from grey to steel-blue, and were found with *Microcoleus chthonoplastes* Gom., *Porphyrosiphon fuscus* Gom. and *Schizothrix longiarticulata* Gardn. The species differs from *S. chalybea* Gom. in the nature of the sheath, size of trichome and configuration of the apical cells.

17. *Schizothrix Lamyi* Gomont. Monogr. Oscill. p. 323, pl. 11, f. 1-3 (1892).

Stratum compact, dark olive-green to green. Filaments moderately elongate, intricate, exceedingly tortuous and pseudo-branched, false branches more or less spread part. Sheaths yellow-gold, firm, very lamellose, irregular at margins and often fimbriate, apices acuminate, turning blue with chlor-zinc-iodine. Trichomes blue-green, few within sheath or solitary, parallel, slightly constricted at cross-walls, 3-4 μ wide; cells generally longer than diameter of trichome, occasionally subquadrate often 4-8 μ long, filled with large protoplasmic granules; apical cell truncate-conical.

Alachua county: Swan Lake, Melrose, *Brannon* 351, 26 June 1946 (C). Calhoun county: barren ground in a high boggy prairie, state highway no. 20, 3 miles west of Blountstown, *Drouet, Crowson & Livingston*, 10710, 10712, 10713, 10714, 10715, 10723, 10 Jan. 1949 (C, F). Escambia county: fresh-water pool, dunes of Gulf beach, *Drouet, Nielsen, Madsen & Crowson* 10539, 10541, 10547, 8 Jan. 1949 (C, F). Holmes county: soil, 5 miles north of Westville, Choctawhatchee river, *C. E. Ruff*, 4 Aug. 1952 (C, F). Jefferson county: soil, Judge Hopkin's camp, Lake Miccosukee, *Nielsen & Crowson*, 956, 11 Mar. 1949 (C, F). Lee county: on dry open sand, region of Hendry creek, about 10 miles south of Fort Myers, *Paul C. Standley* 73208, 11-25 Mar. 1940 (C). Leon county: eroded clay bank, Meridian road between Lake Iamonia and Ochlockonee river, *Drouet, Kurz & Nielsen* 11262, 11263, 11268, 24 Jan. 1949 (C, F). Liberty county: Florida highway no. 20, Ochlockonee river swamp, *Nielsen & Kurz* 392, 19 Feb. 1949 (C, F); Rock Bluff, Apalachicola river valley, *Nielsen & Kurz*, 30 Oct. 1950 (F). Okaloosa county: stream beside U. S. highway no. 98, east of Fort Walton, *H. Tiffany*, 27 Dec. 1948 (C). Walton county: roadside pool, U. S. highway no. 98, 5 miles west of the Walton-Bay county line, *Drouet, Nielsen, Madsen, Crowson & Pates* 10660, 10666, 10667, 9 Jan. 1949 (C, F).

The specimens examined above were frequently found with the following: *Hapalosiphon pumilus* B. & F., *Scytonema figuratum* B. & F., *S. Hofmanii* B. & F., *Schizothrix purpurascens* Gom., *Stigonema panniforme* B. & F., *Tolypothrix tenuis* B. & F. and *Zygonium ericetorum* (Roth.) Kütz. The species has been reported for the state by Madsen & Nielsen (1950).

18. *Schizothrix Heufleri* Gomont. Monogr. Oscill. p. 325, pl. 9, f. 7-8 (1892).

Filaments firm, tortuous, entangled, often divided into fascicles and pseudo-branched. Sheaths steel-blue, or black to blue-green, firm, wide, lamellose, irregular at margins, eroded above, below fimbriate, apices acuminate and generally fibrillar, turning blue with chlor-zinc-iodine. Trichomes blue-green, few within sheath, separate, parallel, generally solitary in a branch, not constricted at cross-walls, 1.7-3 μ wide; cells longer than trichome diameter, 4-8 μ long, sparingly filled with large protoplasmic granules; apical cell moderately attenuate, obtuse.

Broward county: barren ground in Circle, Hollywood blvd., Hollywood, *Drouet & Louderback 10257*, 27 Dec. 1948 (C, F); on cement block in Australian pine woods, south of South lake, Hollywood, *Drouet 10312*, 29 Dec. 1948 (C, F). Lee county: on dry sand, Bonita Beach, *Paul C. Standley 73215*, 14 Mar. 1940 (C); on dry sand, region of Hendry creek, about 10 miles south of Fort Myers, *Paul C. Standley 73352*, 11-25 Mar. 1940 (C). Wakulla county: on bark of tree, south side of spring-pool, Wakulla Springs, *Drouet, Madsen & Crowson 11499*, 27 Jan. 1949 (C, F); on rock in over-flow from Club spring, north of Newport, *D. Blake*, 23 July 1952 (C, F).

The specimens cited were found with *Anacystis montana* (Lightf.) Dr. & Daily, *Porphyrosiphon fuscus* Gom., *Scytonema figuratum* B. & F., *S. ocellatum* B. & F. and *Schizothrix sp.* It has been reported for the state by Madsen & Nielsen (1950).

19. *Schizothrix roseola* (Gardn.) Drouet. Field Mus. Bot. Ser. 20 (6): 132. (1942).

Stratum rose-color to dark, crustaceous; filaments slender, tortuous, flexuous, above united into erect to repent fascicles, below pseudo-branched; sheath at first hyaline and then later rose to dark red and wider, eroded, turning blue with chlor-zinc-iodine; trichomes blue-green, 1-2.5 μ wide, cylindrical, slightly constricted at cross-walls, apices not attenuate; cells subquadrate to longer than diameter, occasionally cross-walls granular, protoplasm very homogeneous; apical cell rotund.

Gadsden county: upland woods, U. S. highway no. 90, 4 miles east of Quincy, *Nielsen, Madsen & Crowson 10430*, 4 Jan. 1949 (G, F); clay bank, Aspalaga, Apalachicola river, *J. E. Harmon 10*, 4 Nov. 1950 (C, F). Lee county: on moist sand, Hendry creek, 10 miles south of Fort Myers, *P. C. Standley 73463*, Mar. 1940 (C).

Liberty county: Rock Bluff, Apalachicola river valley, *Nielsen & Kurz*, 30 Oct. 1950 (C, F). Monroe county: on black mud, plant greyish-white, pine-palm woods, north-west of Inn, sink-hole Big Pine key, *E. P. Killip & Jason R. Swallen 40392*, 25 Mar. 1950 (C).

Stigonema panniforme B. & F. and *Gloeocystis Grevillei* (Berk.) Dr. & Daily are found with the species. It has been reported for the state by Madsen & Nielsen (1950).

20. *Schizothrix Guiseppeii* Drouet. Field Mus. Bot. Ser. 20 (6): 133 (1942).

Stratum blue-green to black-crustaceous. Filaments long in fasciculate branches, below intricate, above joined into erect fascicles repent and often twisted. Sheath at first hyaline finally internally pale blue or steel-blue, wide, lamellose, eroded at margins, turning brilliant blue with chlor-zinc-iodine. Trichomes blue-green or yellowish green, long, straight, fragile, 2-4 μ wide, not constricted at cross-walls, apices abruptly attenuate and acuminate, cells up to 3 times longer than diameter, cross-walls never granular, protoplasm never or scarcely granular, apical cell long and more or less acute conical.

Lee county: on salt flats, region of Hendry creek, about 10 miles south of Fort Myers, *Paul C. Standley 73187*, 11-25 Mar. 1940 (C). Monroe county: on dark greyish muck, near buttonwood section, toward North Pine bridge, Big Pine key, *E. P. Killip 41939*, 18 Feb. 1952 (C).

Specimens may be found with *Schizothrix longiarticulata* Gardn.

21. *Schizothrix violacea* Gardner. Mem. N. Y. Bot. Gard. 7: 52, pl. 11, f. 99 (1927).

Filaments elongate, subrigid, sparingly tortuous, pseudo-branches appressed, often aggregated into repent fascicles; sheaths violet (upon maturity blackish-violet) to apices, rarely hyaline or pale violet, firm, wide, lamellose, frequently eroded at margins, occasionally fimbriate, apices long attenuate and acuminate, turning blue with chlor-zinc-iodine; trichomes pale blue-green, few within sheath, separate, parallel, more often solitary in branch, slightly constricted at cross-walls, 2-2.5 μ wide; cells up to 3 times longer than trichome diameter, rarely subquadrate, 2-7 μ long; protoplasm with dispersed large granules; cross-walls never conspicuous, never granular; apical cell obtuse-conical, without calyptra.

Collier county: dry bank, Marco Island, *Paul C. Standley 73393*, 19 Mar. 1940 (C). Lee county: south of Estero, *Paul C. Standley 92781*, 15 Mar. 1946 (C); between Estero and Bonita Spgs., *Julian A. Steyermark 63199 a*, 10 Mar. 1946 (C).

The thalli of the specimens examined produced a black crustaceous stratum, and were found with *Porphyrosiphon fuscus* Gom. and *Scytonema crustaceum* B. & F.

(To be concluded in Vol. 17, No. 2)

A SIMPLIFIED SYNTHESIS OF 3-AMINO-4-NITRO-BENZOIC ACID AND ETHYL 3-AMINO-4-NITROBENZOATE

By MORRIS J. DANZIG¹ and HARRY P. SCHULTZ
University of Miami

Kaiser (1885) and Thieme (1891) reported the synthesis of 3-amino-4-nitrobenzoic acid; the first synthesis was accomplished by nitration of 3-acetamidobenzoic acid and the second by ammonolysis of ethyl 3-ethoxy-4-nitrobenzoate. Both syntheses, however, required unusual starting materials and gave poor yields of 3-amino-4-nitrobenzoic acid. The need for relatively large quantities of 3-amino-4-nitrobenzoic acid in this Laboratory stimulated development of a new synthesis of this compound.

The new method developed in this Laboratory for the synthesis of 3-amino-4-nitrobenzoic acid was patterned after the synthesis used by Ullman and Uzbachian (1903) for the preparation of 2-amino-5-nitrobenzoic acid from 2-acetamido-5-nitrotoluene.

EXPERIMENTAL PROCEDURES

3-Amino-4-nitrotoluene.—This material was prepared from *m*-acetamidotoluene in 36% yield according to the procedure of Green and Day (1942).

3-Acetamido-4-nitrotoluene.—This substance was prepared by acetylating 3-amino-4-nitrotoluene according to the general procedure given by Fieser and Martin (1935) for the acetylation of *o*-nitroaniline. Using charcoal treatment, the crude reaction product (melting at 80-83°) was recrystallized twice from ligroin (boiling point 90-120°) to give an 84% yield of 3-acetamido-4-nitrotoluene melting at 82-83°. Morgan and Mickelthwaite (1913) reported a melting point of 88-89° for this compound.

3-Amino-4-nitrobenzoic acid.—In a 2-l., three-necked flask equipped with a stirrer, gas inlet tube, and reflux condenser were placed 900 ml. of water and 23.0 g. (0.118 mole) of 3-acetamido-4-nitrotoluene. The temperature of the reaction mixture was raised

¹ Currently post-doctorate fellow, Chemistry Department, University of Minnesota.

to 80°, carbon dioxide was rapidly bubbled into the suspension, and stirring was commenced. Potassium permanganate (18.4 g.) was added, whereupon the temperature of the mixture attained 85°; this temperature was maintained for the remainder of the reaction by using an electric mantle. At thirty minute intervals two more 18.4 g. portions of potassium permanganate were added, making a total of 55.2 g. (0.35 mole) of oxidizing agent added to the reaction mixture. After a total of three hours of reaction time, 10 g. of filter-aid was added to the reaction and the mixture filtered, rinsed, and cooled to room temperature, whereupon the filtrate was again filtered to remove a further small quantity of coagulated manganese dioxide and precipitated starting material.

The filtrate was acidified with 25 ml. of concentrated hydrochloric acid, allowed to stand at 10° for twenty-four hours and filtered. The residue was taken up in 100 ml. of 15% ammonium hydroxide solution and a small quantity of insoluble material was removed by filtration and discarded. The filtrate was again acidified with 50 ml. of hydrochloric acid and cooled at 10° for twenty-four hours; the precipitate was removed by filtration, rinsing and pressing the 3-acetamido-4-nitrobenzoic acid as dry as possible.

The damp 3-acetamido-4-nitrobenzoic acid was transferred to a 1-l., round-bottomed flask and hydrolyzed with a solution of 45 ml. of concentrated sulfuric acid in 75 ml. of water at 90° for two hours. After cooling the reaction mixture in ice water, the 3-amino-4-nitrobenzoic acid was removed by suction filtration, rinsed, and dried to give 12.5 g. (58% yield) of orange powder melting at 299-301°. Kaiser (1885) reported a melting point of 298° and Thieme (1891) reported a melting point of 290° for this substance.

Ethyl 3-amino-4-nitrobenzoate.—Into a 1-l. flask equipped with a condenser and drying tube were placed 200 ml. of absolute ethanol, 5 ml. of concentrated sulfuric acid and 15 g. (0.0825 mole) of 3-amino-4-nitrobenzoic acid. The reaction mixture was refluxed for twenty-four hours, after which the condenser was set for downward distillation, and 150 ml. of solvent was removed. The residue in the reaction flask was poured into 100 ml. of ice water, whereupon ethyl 3-amino-4-nitrobenzoate precipitated. The product was removed by suction filtration, slurried ten minutes

with 50 ml. of 10% sodium bicarbonate solution, re-filtered, rinsed and dried to give 17.0 g. (98.3% yield) of ethyl 3-amino-4-nitrobenzoate melting at 138-139°. Kaiser (1885) reported a melting point of 139° for this substance.

SUMMARY

1. 3-Amino-4-nitrobenzoic acid has been prepared in 58% yield by oxidation of 3-acetamido-4-nitrotoluene with potassium permanganate, removing the protecting acetyl group after the oxidation step had been completed.

2. Ethyl 3-amino-4-nitrobenzoate has been prepared in 98% yield by the direct esterification of 3-amino-4-nitrobenzoic acid with ethanol, using sulfuric acid as a catalyst.

LITERATURE CITED

FIESER, L. F., and MARTIN, E. L.

1935. A Comparison of Benzotriazole with Benzene. *Journal of the American Chemical Society* **57**: 1835-1939.

GREEN, H., and DAY, A. R.

1942. The Tautomeric Character of the Imidazole Ring. *Journal of the American Chemical Society*, **64**: 1167-1173.

KAISER, A.

1885. Ueber Mononitroderivate der p- und m-acetamidobenzoësäure sowie deren Reduktionsproducte. *Berichte der deutschen chemischen Gesellschaft*, **18**: 2942-2952.

MORGAN, G. T., and MICKELTHWAITE, F. M. G.

1913. The Constitution of the ortho-Diazoimines. Part III. The alpha- and beta-Acyl-3,4-tolylenediazoimides as Structural Isomerides. *Journal of the Chemical Society*, **103**: 1391-1404.

THIEME, P.

1891. Ueber die Einwirkung von Ammoniak und Methylamin auf nitrierte Oxybenzoësäureather. *Journal für praktische Chemie*, **43**: 451-482.

ULLMAN, F., and UZBACHIAN, J. B.

1903. Ueber die Verwendung von Permanganaten als Oxydationsmittel. *Berichte der deutschen chemischen Gesellschaft*, **36**: 1797-1807.

A VEGETATIVE KEY TO THE NATIVE AND COMMONLY CULTIVATED PALMS IN FLORIDA

HUGH NELSON MOZINGO
Florida Southern College

Palms, large and small, graceful and grotesque, characterize more than any other plant family the native and cultivated vegetation of Florida. About 14 species are native to Florida, the uncertainty being due to doubt about the taxonomic validity of certain forms.

While this is a relatively small number, two species, *Serenoa repens* and *Sabal palmetto*, are so ubiquitous that it is difficult to be very far out of sight of either one. An attempt has been made to introduce into Florida a large segment, possibly as much as 25%, of the approximately 4,000 species of palms in existence.

Although many such efforts have not met with success, it is probable that at least 500 different species and varieties exist in Florida at the present time. However, despite their abundance, there appears to be no available vegetative key to our common native and introduced forms.

It was with this deficiency in mind that the following key was constructed. Eighty species are treated, including all of the valid native species recognized by Small, the commonly cultivated species, and some of the rarer forms. It is hoped that the following key, inadequate as it may prove to be, will encourage a more complete survey of this group as it occurs here. Native species are designated by an asterisk (*); the dubious native species by a double asterisk (**).

1a.	Palmate leaved species	2
1b.	Pinnate leaved species	34
2a.	Stems very slender, not much over 2.5 cm. in diameter ...	3
2b.	Stems stouter	4
3a.	Leaves with 5 to 10 or more segments, central ones 5 to 7 cm. broad	<i>Rhapis excelsa</i>
3b.	Leaves with 7 or 8 segments, usually not more than 3 cm. broad	<i>Rhapis humilis</i>
4a.	Trunk none or creeping	5

- 4b. Trunk evident, usually tall 8
- 5a. Stem with numerous long, sharp, black spines
 —*Rhapidophyllum hystrix**
- 5b. Stem without spines 6
- 6a. Petioles with spines along the margins *Serenoa repens**
- 6b. Petioles without spines 7
- 7a. Midrib none *Sabal minor**
- 7b. Midrib extending nearly through the blade ... *Sabal etonia**
- 8a. Spines present on petioles 9
- 8b. Spines absent on petioles 21
- 9a. Leaves 60 cm. wide, or less 10
- 9b. Leaves over 60 cm. wide 12
- 10a. Petioles armed with large, sharp spines; leaves not cor-
 date at the base 11
- 10b. Petioles armed with numerous small, sharp spines; leaves
 cordate at the base *Serenoa repens* (erect form)*
- 11a. Leaves rigid, rarely over 60 cm. wide; trunk rarely over
 1 m. high; spines black *Chamaerops humilis*
- 11b. Leaves somewhat lax, 60 to 90 cm. wide; trunk up to 12
 m. high (petioles with flat, orange, upcurved spines)
 —*Paurotis wrightii**
- 12a. Most leaves between 60 and 90 cm. wide
 —*Paurotis wrightii**
- 12b. Leaves well over 90 cm. wide 13
- 13a. Leaves over 1.8 m. wide *Corypha utan*
- 13b. Leaves under 1.8 m. wide 14
- 14a. Petioles lightly or heavily tomentose; stocky palms with
 large rigid leaves 15
- 14b. Not as above 17
- 15a. Leaves very glaucous *Latania loddigesii* (juvenile form)
- 15b. Leaves not glaucous 16
- 16a. Leaves light green; petiole heavily tomentose, margins
 orange *Latania verschaffeltii* (juvenile form)
- 16b. Leaves darker green; petiole lightly tomentose, margins
 red *Latania borbonica* (juvenile form)
- 17a. Leaves somewhat recurved 18
- 17b. Leaves not recurved 20
- 18a. Petioles spiny throughout their length .. *Livistona australis*
- 18b. Only the lower portion of the petioles spiny 19

- 19a. Lower half of the petiole with hard, brown spines, up to 15 mm. long *Livistona chinensis*
- 19b. Lower half of the petiole with larger, crooked, shiny brown spines *Livistona rotundifolia*
- 20a. Leaf segments margined with very numerous stiff fibers; leaves gray-green (not glaucous); petioles usually armed to the middle or somewhat beyond with stout, hooked spines; trunk very stout, not usually expanded at the base
—*Washingtonia filifera*
- 20b. Leaf segments with few fibers, except when young; leaves bright green; petioles usually with spines mostly throughout their length; trunk not as stout, expanded at the base
—*Washingtonia robusta*
- 21a. Leaves rigid, or only slightly drooping 22
- 21b. Leaves not rigid, leaf tips very obviously drooping (see also 28) 30
- 22a. Leaves very glaucous on both surfaces ... *Latania loddigesii*
- 22b. Leaves not glaucous at maturity on both surfaces 23
- 23a. Leaf base cuneate 24
- 23b. Leaf base not cuneate 25
- 24a. Leaf segments about 90 *Pritchardia pacifica*
- 24b. Leaf segments about 50 to 60 *Pritchardia thurstonii*
- 25a. Slender tree covered with coarse, matted root-like fibers *Coccothrinax miraguama*
- 25b. Not as above 26
- 26a. Petioles tomentose 27
- 26b. Petioles not tomentose 28
- 27a. Leaves light green at maturity, when young, reddish or purplish; petioles heavily tomentose, margins orange
—*Latania verschaffeltii*
- 27b. Leaves darker green at maturity, when young, distinctly yellowish; petioles lightly tomentose, margins red
—*Latania borbonica*
- 28a. Dwarf, maximum height of 2 m.; slender petioles; leaves bright green *Thrinax morrisii*
- 28b. Taller; not as above 29
- 29a. Stout tree; long pliable petioles; leaves light green above *Thrinax microcarpa**

- 29b. Slender tree; petioles shorter and stiff; leaves yellow green above *Thrinax parviflora**
- 30a. Trunk very slender, under 15 cm.; leaves silvery beneath *Coccothrinax argentata**
- 30b. Not as above 31
- 31a. Trunk slender, with a covering of coarse, black fibers; leaves up to 1.2 m. wide *Trachycarpus fortunei*
- 31b. Trunk not as above; leaves frequently larger 32
- 32a. Ligule less than 12 cm. long; trunk moderately stout; leaves green *Sabal palmetto**
- 32b. Not as above 33
- 33a. Trunk massive; ligule usually not over 15 cm. long; leaves not glaucous, segments about 60, with abundant fibers
—*Sabal causiarum*
- 33b. Trunk not so massive, frequently thickened in the middle; ligule 15 cm. long or longer; leaves glaucous, segments about 80, with fewer fibers *Sabal umbraculifera*
- 34a. Trunk spiny 35
- 34b. Trunk not spiny 40
- 35a. Leaf segments broad, wedge-shaped, apex truncate and ragged *Aiphanes caryotaefolia*
- 35b. Leaf segments not as above 36
- 36a. Trunk very slender, to 4 cm. wide 37
- 36b. Trunk considerably stouter 38
- 37a. Trunk 2.5 to 4 cm. in diameter; leaves dull green
—*Bactris major*
- 37b. Trunk to 2 cm. in diameter; leaves gray-green .. *Bactris minor*
- 38a. Spines on the petiole bases, trunk smooth after those have fallen *Acrocomia hospes*
- 38b. Spines on the trunk 39
- 39a. Trunk fusiform; leaves bluish to gray beneath
—*Acrocomia armentalis*
- 39b. Trunk cylindrical; leaves green beneath *Acrocomia totai*
- 40a. Trunk smooth, or relatively so 41
- 40b. Trunk not smooth, frequently with leaf bases remaining attached 66
- 41a. Leaf segments cuneate or delta-shaped 42
- 41b. Leaf segments not as above 43
- 42a. Leaves 1.2 to 2.7 m. long; producing suckers; stem with a maximum diameter of 13 cm. *Caryota mitis*

- 42b. Leaves 5.5 to 6 m. long; not producing suckers; stem much larger in diameter *Caryota urens*
- 43a. Sheathing petiole bases forming a prominent green column atop the trunk 44
- 43b. Sheathing petiole bases not forming a prominent green column atop the trunk 55
- 44a. Trunk slender, less than 13 cm. wide, with a characteristic swelling at the base; leaf segments erose at the apex
—*Ptychosperma elegans*
- 44b. Not as above 45
- 45a. Trunk disproportionately stout for its height; leaves 1 to 2 m. in length 46
- 45b. Not as above 47
- 46a. Trunk sometimes bulged below leaf cluster; leaf segments about 60 cm. long, 2.5 to 4 cm. wide, lateral veins not prominent *Mascarena verschaffeltii*
- 46b. Trunk bulged near base, frequently constricted at the top; leaf segments 30 to 40 cm. long, 5 cm. wide or wider, with prominent lateral veins *Mascarena lagenicaulis*
- 47a. Trunk characteristically slightly bulged near the middle or upper part 48
- 47b. Trunk not as above 50
- 48a. Leaf segments with prominent lateral veins; maximum height of 12 to 18 m. *Roystonea regia*
- 48b. Leaf segments not prominently ribbed or veined 49
- 49a. Maximum height of 27 to 30 m.; trunk light gray
—*Roystonea elata**
- 49b. Maximum height of 9 to 14 m.; trunk darker, more prominently bulged near the middle *Roystonea borinquena*
- 50a. Trees with slender trunks, bulged at the base; leaf segments 5 to 7.5 cm. wide 51
- 50b. Trees or leaf segments not as above 52
- 51a. Leaf segments with long tapering points and prominent lateral veins *Dictyosperma album*
- 51b. Leaf segments short-pointed and with indistinct lateral veins; young leaves with orange-colored veins
—*Dictyosperma aureum*
- 52a. Short, maximum height about 6 m.; trunk stout, tapering; leaves glaucous with very prominent lateral veins
—*Adonidia merrillii*

- 52b. Taller; cylindrical trunk slender or stout 53
- 53a. Trunk slender; leaf segments ashy-glaucous beneath, secondary nerves quite prominent ... *Archontophoenix alexandrae*
- 53b. Not as above 54
- 54a. Longer leaf segments to 45 cm., green beneath; slender trunk more prominently ridged by leaf scars than the following *Archontophoenix cunninghamiana*
- 54b. Leaf segments in one plane, longest about 1 m.; trunk stouter, less prominently ridged by leaf scars than the above, perfectly cylindrical *Roystonea oleracea*
- 55a. Leaf segments obliquely cut and erose-dentate at the apex; stems suckering freely *Actinophloeus macarthuri*
- 55b. Leaf segments not obliquely cut at the apex 56
- 56a. Leaf segments relatively few (14 to 24); stems very slender, to 4 cm. thick *Chamaedorea elegans*
- 56b. Leaf segments more in number; stems over 6 cm. thick ... 57
- 57a. Trunk relatively slender, not much over 6 cm. thick 58
- 57b. Trunk not slender 62
- 58a. Trunks usually in clumps; leaves gracefully arched, yellow green; trunk 10 to 15 cm. in diameter
—*Chrysalidocarpus lutescens*
- 58b. Not as above 59
- 59a. Petiole length not over 1/5 of blade length 60
- 59b. Petiole length considerably over 1/5 of blade length ... 61
- 60a. Leaves short petioled (1/7 of the leaf), resembling *Roystonea* species; mature trunk with swollen base
—*Gaussia attenuata*
- 60b. Leaves longer petioled (1/5 of the leaf), somewhat arched, deep green; trunk not swollen at the base .. *Heterospathe elata*
- 61a. Leaves about 3 m. long; very long petioles; leaf segments quite definitely drooping *Howea forsteriana*
- 61b. Leaves 2 m. long or less; petioles considerably shorter than above; leaf segments not as prominently drooping
—*Howea belmoreana*
- 62a. Leaves quite erect, dark green; tall tree to 18 m.
—*Orbignya cohune*
- 62b. Leaves not erect 63
- 63a. Trunk swollen in part 64
- 63b. Trunk not ordinarily swollen 65

- 64a. Trunk swollen at base; leaves to 5.5 m. long, yellow green *Cocos nucifera***
- 64b. Trunk swollen near middle; leaves to 2 m. long, dark green *Pseudophoenix sargentii***
- 65a. Leaf outline long lanceolate, segments in groups of 2 to 4 along rachis *Arecastrum romanzoffianum*
- 65b. Leaf outline somewhat orbicular, segments not in groups along rachis *Hedyscepe canterburyana*
- 66a. Leaves decidedly glaucous 67
- 66b. Leaves not prominently glaucous, or if so, leaves not strongly recurved 69
- 67a. Tip of leaf segments cut into two narrow divergent lobes at least 2.5 cm. long *Butia eriospatha*
- 67b. Tip of leaf segments not usually cut deeper than 2 cm., lobes not divergent 68
- 68a. Leaves to 3 m. long; middle leaf segments about 2.5 cm. wide; trunk to 7.5 m. tall *Butia yatay*
- 68b. Leaves to 2 m. long; middle leaf segments narrower; trunk shorter *Butia capitata*
- 69a. Leaflets conspicuously drooping; petioles with 2.5 to 4 cm. spines; long stick-like petiole bases clothing stem
—*Arikuryroba schizophylla*
- 69b. Not as above 70
- 70a. Leaves white-glaucous below; leaf segments erose-dentate *Wallichia caryotoides*
- 70b. Not as above 71
- 71a. Petioles spiny serrate *Elaeis guineensis*
- 71b. Petioles, if spiny, with the lower leaf segments modified into spines 72
- 72a. Trunk small and bulb-shaped, not elongated 73
- 72b. Trunk not bulb-shaped 74
- 73a. Leaf segments very rigid; fascicles tending to be opposite *Phoenix acaulis*
- 73b. Leaf segments soft; fascicles irregularly arranged
—*Phoenix humilis*
- 74a. Base of petiole very abruptly and widely flaring
—*Jubaea spectabilis*
- 74b. Base of petiole becoming wider, but not very abruptly flared 75

- 75a. Young stem prominently covered with long, black coarse fibers *Arenga saccharifera*
- 75b. Stem not so covered 76
- 76a. Leaf segments soft 77
- 76b. Leaf segments rigid 79
- 77a. Small palm; short, slender trunk 78
- 77b. Much larger, to 6 m. tall; leaves shiny, yellow green; leaf segments tending to be in one plane *Phoenix rupicola*
- 78a. Leaf segments decidedly drooping; trunk clothed with old clasping, persistent petiole bases *Syagrus Weddelliana*
- 78b. Leaf segments not as prominently drooping; trunk with knob-like stumps of petiole bases *Phoenix loureirii*
- 79a. Trunk short (to 1.2 m.) and stout; leaves 1.2 to 1.5 m. long *Phoenix pusilla*
- 79b. Trunk and leaves not as above 80
- 80a. Leaf segments 17 to 25 cm. long, bright green; slender trunk, small to 6 m. *Phoenix zeylanica*
- 80b. Not as above 81
- 81a. Leaf segments sword-shaped, whitish or mealy beneath; trunk 8 to 10 cm. in diameter, 2.5 to 8 m. tall
..... —*Phoenix paludosa*
- 81b. Not as above 82
- 82a. Trunk slender, usually leaning, with many suckers at the base *Phoenix reclinata*
- 82b. Trunk stouter, not usually with many suckers at the base .. 83
- 83a. Leaves slender, gracefully arching; trunk massive
..... —*Phoenix canariensis*
- 83b. Leaves stouter and shorter; trunk not so massive 84
- 84a. Leaves glaucous *Phoenix dactyliferu*
- 84b. Leaves not glaucous *Phoenix sylvestris*

Acknowledgment

The author is grateful to his wife, Katherine W. Mozingo, for her gracious help in the preparation of the manuscript for publication.

REFERENCES

ARNOLD, L. E.
 1937. Check list of Native and Naturalized Trees in Florida. *Proc. Fla. Acad. Sci.* 2: 52-66.

BAILEY, L. H.

1934. American Palmettoes. *Gentes Herbarum* 3: 274-337.
 1935. The Royal Palms—Preliminary Survey. *Gentes Herbarum* 3: 342-387.
 1936. The Butias. *Gentes Herbarum* 4: 16-50.
 1936. Washingtonia. *Gentes Herbarum* 4: 52-82.
 1942. Palms of the Mascarenes. *Gentes Herbarum* 6: 50-104
 1943. New Palms in Panama, and others. *Gentes Herbarum* 6: 198-264.
 1943. *The Standard Cyclopedia of Horticulture*. The Macmillan Co., New York.
 1944. Revision of the American Palmettoes. *Gentes Herbarum* 6: 366-459.
 1949. *Manual of Cultivated Plants*. The Macmillan Co., New York.

COKER, W. C., and H. R. TOTTEN

1937. *Trees of the Southeastern States*. Univ. of N. C. Press, Chapel Hill.

EICK, MARY NUNEZ TEN

1950. *Florida Plant Checklist*. Life Line Prtg. & Book Co., Inc., Tampa.

HARPER, R. M.

1949. A Preliminary List of the Endemic Flowering Plants of Florida. *Quart. Journ. Fla. Acad. Sci.* 11: 25-35; 39-57.
 1950. A Preliminary List of the Endemic Flowering Plants of Florida. *Quart. Journ. Fla. Acad. Sci.* 12: 1-19.

MOWRY, HAROLD (Revised by R. D. Dickey and Erdman West)

1952. Native and Exotic Palms of Florida. *Fla. Agric. Ext. Serv. Bull.* 152.

SMALL, J. K.

1933. *Manual of the Southeastern Flora*. The Sci. Press Prtg. Co., Lancaster.

WEST, ERDMAN, and LILLIAN E. ARNOLD

1946. *The Native Trees of Florida*. Univ. of Fla. Press, Gainesville.

A METHOD FOR PREPARING AND MOUNTING THIN GROSS SECTIONS OF HUMAN OR OTHER LARGE BRAINS

GRANVILLE C. FISHER, PH.D. and FREDERIC D. GARRETT, PH.D.

University of Miami

Mechanical models of the brain have been used effectively for teaching purposes. However, they are limited by the fact that they are imitations, and never leave the serious student quite satisfied as to the true characteristics of the real object of study. The possibility of providing the student with objective study material that would enable him literally to leaf through the brain, with the sections oriented in each of the three cardinal planes, has been of interest to the authors for some time. It could be accomplished in some fashion after the manner of Polyak's excellent series of transparencies on the eye. But here again the student is not presented with the actual material. The mounting of sections of the brain in plastic has been attempted with some success. The major objection to this method has been that the thickness of the sections often left unrevealed small structures such as the mammillo thalamic tract, etc. If the sections could be no more than one-eighth or one-sixteenth of an inch in thickness, and mounted successfully in some plastic container, this would seem to be an ideal manner of presenting gross sections of the whole brain for study. But how can gross sections of the brain be sliced so thinly without falling to pieces or without giving rise to other difficulties? By combining information from several sources, and by putting such information to the empirical test, the authors herewith report in detail a procedure which has proved most gratifying, and leaves very little to be desired.

To obtain the best specimen, one should secure a fresh brain, and allow it to remain about one month in a fifteen or twenty percent solution of formalin. An adjustable wooden mold should be constructed of $\frac{3}{4}$ " plywood, following the design of Figure 1. Five C-clamps with $1\frac{1}{2}$ " openings will be needed. The inside dimensions may be adjusted to accommodate the brain. The C-clamps allow for its disassembling without force. When the mold is assembled, the joints should be sealed on the inside with wet

potter's clay. The brain may now be placed in the mold and held away from the bottom and from the sides by waste pieces of other brains. Around the brain we can now pour a supporting medium which has been prepared as follows: mix 900 gms. fine white cornmeal and 750 gms. commercial granulated gelatin in 3500 cc. water and boil until the cornmeal is well softened. The cornmeal appears to provide a consistency to the mass which ensures greater regularity in the slices which cannot be gained by use of the gelatin alone. The hot mixture is then poured slowly around the brain, covering it entirely. When the mixture has thoroughly cooled (postponing operations until the following day is a safe procedure) it constitutes a firm supporting mass. The C-clamps should now be loosened, and the walls of the form separated from the gelatin, except for the one wall parallel to the line of slicing. The gelatin should not be loosened from this form wall for reasons which we shall soon understand.

The block of gelatin still attached to the one form, and with the brain embedded, is now placed on a hand-operated meat slicing machine such as is used in a butcher shop. Before the wooden forms are constructed, measurements should be taken of the slicing machine intended for use in order that the proper fit may be assured. It will be seen now that the attached form wall lends support to the gelatin mass, reducing the possibility of distortion during the slicing operation. Uniform sections down to one sixteenth of an inch in thickness can now be obtained with ease. The gelatin affords enough support to keep the brain slices intact if care is exercised in their handling after cutting. The slices may be stored indefinitely in 10% formalin prior to mounting.

For mounting, $\frac{1}{8}$ " plexiglas is cut on a circular saw in sizes 6" x 7" and for the separating strips at the edges, $\frac{1}{8}$ " x $\frac{1}{4}$ ", following essentially the method described by Farner, Pence and Moëller. In preparation for receiving the brain specimen, a "tray" is prepared by fastening $\frac{1}{8}$ " x $\frac{1}{4}$ " strips to all four sides of one 6" x 7" sheet of plexiglas. The strips are fastened by moistening generously with trichlorethane, using an eyedropper for applying, and then clamping with spring clamps for about thirty minutes. As many such trays should be prepared ahead of time as there are brain sections to be mounted. One can anticipate this by

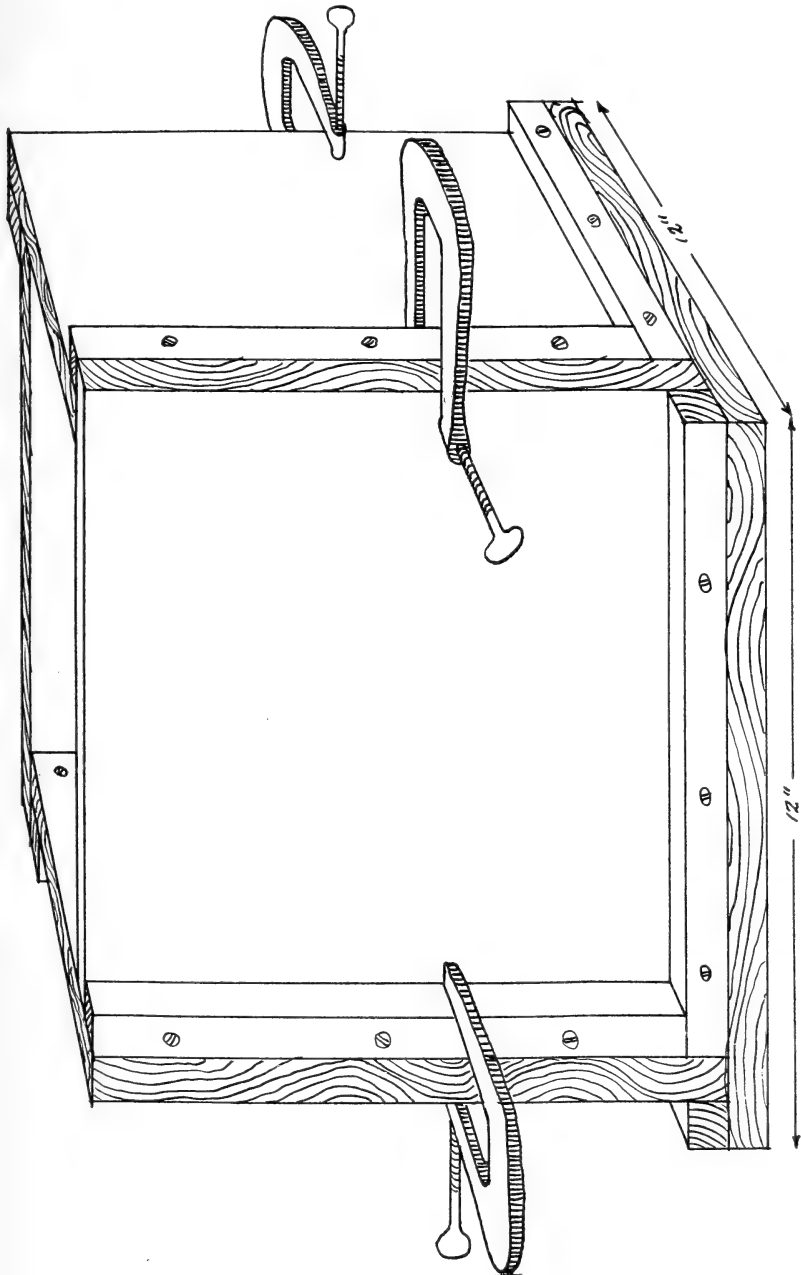

Figure 1.

measuring the brain before embedding it in the gelatin. At the time of mounting one should have at hand a supply of clear liquid gelatin and a brush about 1" in width. The plexiglas tray is painted with the gelatin on the inside, and onto this gelatin is placed immediately the brain section, the surrounding gelatin-cornmeal having just been removed. At this point the separator strips are moistened with the solvent, and a second 6" x 7" sheet of plexiglas is pressed and clamped on as a cover. It should remain clamped for about thirty minutes. At the end of this time a hole large enough to accommodate the needle of a hypodermic syringe is bored in one of the corners. The syringe is filled with a 10% solution of formalin which is then injected into the interior of the plexiglas box until it is filled. The needle is withdrawn and the hole filled with plexiglas "dust" mixed with a bit of the solvent, making the box now air-tight. The specimen is now mounted and ready for use.

Sections may be mounted unstained, or stained to emphasize contrast between gray and white matter. The authors have used a one per cent solution of nigrosin for this purpose.

It is felt that a detailed presentation of this method will render it available to interested persons, and that it may suggest other uses to which it may be put.

The authors wish to express their thanks to Dr. Robert T. Hill, Chairman of the Department of Anatomy, University of Miami Medical School, and Mr. J. Richard McElheny, Department of Education, for their support and suggestions which have made this project possible.

REFERENCES

FARMER, T. W., L. M. PENCE and M. MOELLER

1951. A Simple Method of Mounting Gross Biologic Material in Plastic Boxes. *Science*, 114(2957): 236-237; 3 figs.

MEMBERSHIP LIST OF THE FLORIDA ACADEMY OF SCIENCES

- Adams, Miller K., 3205 Obispo St., Tampa 9, Physical Education
Addington, Conley R., University of Miami, Accounting
Albertson, Mary Susan, Route 3, Box 127, West Palm Beach, Fla., Biology
Alexander, Taylor R., University of Miami, Botany
Allabough, Edwin D. Jr., Box 1719, Delray Beach, Fla., Biology and Physical Sciences
Allee, W. C., University of Florida, Biology
Allen, E. Ross, Florida Reptile Institute, Silver Springs, Fla., Herpetology
Allen, Ezra, 223 W. Minnesota Ave., Deland, Fla., Biology
Allen, Francis, 1536 Christobal Dr., Tallahassee, Sociology
Allen, Howard D., 205 W. Myrtle St., Lakeland, Fla., Chemistry
Allen, John S., University of Florida, Astronomy
Allen, Robert P., Box 205, Tavenier, Fla.
Allison, R. V., University of Florida, Everglades Experiment Station, Belle Glade, Biology
°Almodovar, Luis R., Florida State University
°Anderson, James Robert, Florida Southern College, Lakeland, Biological Sciences
Anderson, J. V., Florida A. & M. College, Social Sciences
Anderson, Stuart L., Florida Southern College, Biology
Andrews, Alfred C., 3734 Main Highway, Miami 33, Social Sciences
Andrews, Mrs. Dorothy, Box 87, Brewster Hall, Bradenton, Fla., Psychology
Argus, Mary Frances, University of Florida, Cancer Research
Arnold, Lillian E., University of Florida, Agricultural Experiment Station, Taxonomic Botany
°Azoff, Manuel, 1430 Marseille Dr., Miami Beach, Biology
Badgley, W. J., University of Miami, Chemistry Dept., Physical Sciences
Barrett, Mary F., 70-A Fremont St., Bloomfield, N. J., Botany
Baum, Werner A., Florida State University, Meteorology and Physics
°Baumel, Julian J., Creighton University, Omaha, Nebraska, Medicine
°Bayless, William J., Box 644, Anna Maria, Fla., Physical Sciences
°Beach, Judy, 14 Princeton Pl., Lakeland, Fla., Biological Sciences
Beard, Harold C., Florida State University, Chemistry
Beck, Elizabeth, 1621 River Bluff Rd., Box 443, Arlington, Fla., Entomology
Becker, H. F., Florida State University, Geography
Becknell, G. G., University of Tampa, Physics
Beery, John R., Dean, School of Education, University of Miami
Beidler, Lloyd M., Florida State University, Physiology
°Belanger, Larry, RFD 1, Box 281, Winter Haven, Fla., Social Sciences
Bellamy, R. E., 2311 B St., Bakersfield, California, Entomology
Bellamy, R. F., Florida State University, Sociology
Benfield, Charles W., Box 2051, Orlando, Physical Sciences

° Collegiate Member.

- Berner, Lewis, University of Florida, Entomology
 Bernstein, Clarence, 740 N. Magnolia Ave., Orlando, Medicine
 *Berry, Frederick, Flavet 1, Apt. 320-C, University of Florida, Biological Sciences
 Bignell, James, University of Tampa, Physical Sciences
 Bird, L. C., 303 S. 6th St., Richmond, Va., Business
 Black, A. P., University of Florida, Chemistry
 Bless, Arthur, University of Florida, Physics
 Bly, R. S., Florida Southern College, Chemistry
 Boles, Leo L., Little River School, Miami, Physical Science & Chemistry
 Boliek, Irene M., Florida State University, Zoology
 Boyd, Mark F., 615 E. 6th Ave., Tallahassee, Epidermiology
 Boynton, J. O., University of Florida, Geography
 Brautlecht, Charles A., 332 Phelps Ave., Winter Park, Physical Sciences
 Breder, C. M., Jr., American Museum of Natural History, Ichthyology
 Breen, Ruth S., Florida State University, Botany
 *Breidenbach, Andrew W., University of Florida, Biological Sciences
 Brey, Wallace S., Jr., 1503 NW 11th Rd., Gainesville, Physical Sciences
 *Briggs, Marjorie, University of Florida, Biology
 Brillhart, William, Emory University, Biological Sciences
 *Brindle, Mary H., R.D. No. 2, Box 94, Ft. Lauderdale, Biology & Social Sciences
 Brodkorb, Pierce, University of Florida, Biology
 *Brown, Arden, Florida State University
 Brues, C. T., Georgetown, Florida, Zoology
 Buckland, Charlotte, 2623 Herschel St., Jacksonville, Biology
 Bullen, Ripley P., 103 Seagle Bldg., Gainesville, Archaeology
 Bullen, Mrs. Adelaide K., 103 Seagle Bldg., Gainesville, Anthropology
 *Burgeson, John W., Florida State University, Physics
 Burgess, William D., Florida Christian College, Tampa
 Burke, Rev. Cyril, Barry College, Miami, Political Science
 Burton, B. S., Jr., Box 2024, University Station, Gainesville, Physical Sciences
 *Bushong, Allen D., 627 SW 12th St., Gainesville, Social Sciences
 Butcher, F. Gray, University of Miami, Entomology
 Byers, C. Francis, University of Florida, Zoology
- Caldwell, Miss Ann, 103 E. Park St., Auburndale, Fla., Biological Sciences
 Caldwell, David K., University of Florida, Biology
 *Caldwell, Harry B., Jr., Box 163, Florida Southern College, Biological Sciences
 Campbell, Doak S., Florida State University, Education
 Campbell, Robert B., Route 3, Box 573, Ft. Myers, Geology
 Cantrell, Irving J., Edwin S. George Reserve, Pinckney, Mich., Zoology
 Carr, A. F., Jr., University of Florida, Zoology
 Carratt, Chris A., Box 562, Stetson University, Social Sciences
 Carroll, Don W., Rollins College, Physical Sciences
 *Carter, Charles L., Florida State University, Economics & Social Sciences
 Carter, Claude F., 5970 SW 46th St., Miami, Physical Sciences
 Carter, John V., Box 111, Curundu, Canal Zone, Peruvian Archaeology

- Carter, Mrs. John V., Box 111, Curundu, Canal Zone, Peruvian Archaeology
 Carver, W. A., University of Florida, Cotton Breeding
 Case, Egbert A., Florida Southern College, Mathematics
 Chace, James E., Jr., 1014 NE 5th St., Gainesville, Labor & Personnel
 Chauvin, Robert S., Stetson University, Social Sciences
 °Clark, Charles W., Florida Southern College, Biological Sciences
 Clark, Sarah, 216 Verona St., Kissimmee, Fla., Chemistry
 Clayton, H. G., University of Florida, Agriculture
 Clouse, J. H., University of Miami, Physics
 °Coggan, William G., Florida State University
 Cogan, Eric S., 424 Lake Bonny Dr., Lakeland, Social Sciences
 Conn, John F., Box 655, Deland, Fla., Chemistry
 Conner, Ruth, Florida State University, Home Economics
 Collins, Margaret S., Florida A. & M., Tallahassee, Biological Sciences
 Cook, D. H., University of Miami, Chemistry
 Cook, Dr. Thomas J., 1342 du Pont Bldg., Miami, Fla.
 Corrington, Julian D., University of Miami, Zoology
 Coulson, John, 811 S. Rome Ave., Tampa, Physics
 Covington, James W., Tampa University, Social Sciences
 Craig, Palmer, Box 56, University Station, Miami, Physics
 Creveling, Harold F., 1701½ Jetton Ave., Tampa, Social Sciences
 Crist, Raymond E., University of Florida, Geography
 Cross, Clark I., University of Florida, Geography
 Cumming, Robert B., Box 3065, University Station, Gainesville, Biological Sciences
 °Curl, Herbert Jr., 202 Bradford Rd., Tallahassee, Biological Sciences
- D'Aguanna, William, Florida State University, Biology
 Dambaugh, Luella N., University of Miami, Geography
 °Darlington, Julian T., 61 NE Barksdale Dr., Atlanta, Biological Sciences
 Davis, John H., University of Florida, Botany
 °Day, Orvis E., P. O. Box 74, Greenville, Fla., Biological Sciences
 Deedmeyer, George, 3958 Park Ave., Miami, Business
 Dees, Jesse W., Jr., Bethune-Cookman College, Daytona Beach, Social Sciences
 DeMelt, W. E., 419 E. Maxwell St., Lakeland, Social Sciences
 Denyes, Helen A., Florida State University, Physiology
 Dequino, John F., Box 251, Leesburg, Fla., Conservation
 Deviney, Ezda, Florida State University, Zoology
 Dickinson, J. C., Jr., University of Florida, Ornithology
 Dickson, John D., 7534 Hardee Dr., S. Miami, Biological Sciences
 Dietrich, T. Stanton, Route 3, Box 25-C, Tallahassee, Sociology
 Dietrich, Sigismond DeR., University of Florida, Geography
 Dijkman, Marinus J., 4013 Douglas Rd., Coconut Grove, Fla., Agronomy
 Dittmer, Karl, Florida State University, Physical Sciences
 Dodd, Dorothy, State Library, Box 814, Tallahassee, History
 Drach, Mildred A., 175 Lake Morton Dr., Lakeland, Social Sciences
 Duggan, Sister Ann Charler, Barry College, Miami, Physical Sciences

- Duke, Douglas, 1939 NW 2nd Ave., Gainesville, Physical Sciences
 Dunning, Wilhelmina F., University of Miami, Microbiology
 Dyer, Donald R., University of Florida, Geography
 Dyrenforth, Lucien Y., 3885 St. Johns Ave., Jacksonville, Medicine & Chemistry
 *Earle, Lewis S., 735 Wilkie St., Dunedin, Fla., Physical Sciences
 Eddy, Walter H., 5610 Georgia Ave., W. Palm Beach, Chemistry
 Edson, Seton N., Box 2002 University Station, Gainesville, Biology
 Edwards, Richard A., University of Florida, Geology
 Elliott, John E., 108 W. 15th, Austin, Texas, Petroleum Economics
 Ellis, Walter H., Box 168, Florida A. & M. College, Physical Sciences
 Erck, G. H., P. O. Box 448, Leesburg, Fla., Horticulture
 *Ericson, Mrs. Sylvia E., Florida State University, Biological Sciences
 *Ericson, Wallace W., Box 312, Dunedin, Fla., Physical Sciences
 Evans, Elwyn, 601 Magnolia Ave., Orlando, Medicine
 Ewing, Upton C., 362 Minorca Ave., Coral Gables, Biological Sciences
- Fairchild, David, 4013 Douglas Rd., Miami, Botany
 Fargo, William G., 506 Union St., Jackson, Mich., Ornithology
 Fearney, Edward M., University of Florida, Social Sciences
 Feaster, John P., University of Florida, Biological Sciences
 *Fenstermaker, Quincy Belle, 4125 Park St., St. Petersburg
 *Ficarrotta, Frank Jr., Apt. 235-C, Flavet III, Gainesville, Social Sciences
 Finner, Paul F., Florida State University, Psychology
 Fisher, Fran E., Citrus Experiment Station, Lake Alfred, Fla., Biology
 Fisher, Granville C., 3518 S. Moorings Way, Coconut Grove, Psychology
 Flowers, John W., University of Florida, Physics
 Fogle, Orin G., Box 695, Hallandale, Fla., Biology
 Foote, Perry A., University of Florida, Pharmacy
 Ford, Ernest H., University of Florida, Botany
 Frish, Harry M., P. O. Box 153, Okeechobee, Fla., Biology
 Frye, O. E., Jr., Game & Fresh Water Fish Commission, Tallahassee, Biology
 Fuller, Walter P., 505 Florida Theatre Bldg., St. Petersburg, Social Sciences
 Furman, Rev. W. L., University of Florida, Physics
- Gager, William A., University of Florida, Mathematics
 Gathman, Craig A., 1101 21st Ave., N., Lake Worth, Fla., Biology
 Geer, Lawrence P., 2506 Morrison Ave., Tampa, Bacteriology
 Geltz, Charles G., University of Florida, Forestry
 George, T. S., 43 Riverside Dr., Patrick AFB, Cocoa, Fla., Mathematics
 *Gibson, Ronald, Box 235, Cantonment, Fla., Physical Sciences
 Gilbert, Norman E., Rollins College, Physics
 Gildea, Ray Y., University of Florida, Social Sciences
 Gilman, Lauren C., University of Miami, Zoology
 Gist, M. N., Box 7, McIntosh, Fla., Native Plants
 Goddard, Morrill Jr., 4370 SW 5th Terrace, Miami, Zoology
 Goethe, C. M., 720 Angelo Bank Bldg., Sacramento, Calif., Biological Sciences
 Goggin, John M., University of Florida, Archaeology
 Goin, Coleman, University of Florida, Biology

- Goldsmith, William M., University of Tampa, Biology
 Grace, H. T., Florida Southern College, Geography
 Graff, Mary B., Mandarin, Fla., Social Sciences
 Gratz, L. O., University of Florida, Plant Pathology
 Graybiel, Ashton, School of Aviation Med., NAS, Pensacola, Medical Research
 Gregg, James H., University of Florida, Biology
 Griffith, Mildred, University of Florida, Botany
 Grobman, Arnold B., University of Florida, Biology
 Grunwald, Ernest, Florida State University, Chemistry
 *Guccione, Ignatius, 711 Hollingsworth Rd., Lakeland, Biology
 Gunn, Colin D., Micanopy, Fla., Social Sciences
 Gut, H. J., Box 700, Sanford, Fla., Vertebrate Paleontology
- Haas, Mrs. Flora A., Box 623, Sorrento, Fla., Biology
 Haeger, James S., Box 308, Vero Beach, Fla., Biological Sciences
 Hall, Arthur, Lt., USN School of Aviation Med., NAS, Pensacola
 Hamilton, Henry G., University of Florida, Agricultural Economics
 Hamilton, Steve F. Jr., 2936 Vineville Ave., Macon, Ga., Geography
 Hanks, Robert W., Florida State University, Botany
 Hanna, A. J., Rollins College, History
 Hansen, Keith L., University of Florida, Biology
 Hanson, Harold P., University of Florida, Physical Sciences
 *Hargis, William J., Florida State University, Biological Sciences
 Harper, Roland, University of Alabama, Plant Geography
 Hart, Sister Mary Jane, Barry College, Miami, Chemistry
 Hartz, Edwin R., Weapons Training Battalion, USMC, Parris Island, S. C.
 *Hauke, Richard, 16843 Littlefield, Detroit 35, Mich., Biological Sciences
 Hawkins, J. E., University of Florida, Chemistry
 Hayward, Wyndham, Lakemont Gardens, Winter Park, Fla., Horticulture
 Hazzard, William L., Jr., 801 NE 88th St., Miami, Chemistry
 Hendrix, Major Wilson H., Route No. 3, Box 631, Gainesville, Social Sciences
 Henry, Laura M., 365 Hawthorne Ave., Palo Alto, Calif., Zoology
 *Herblin, William F., P. O. Box 394, Maitland, Fla., Physical Sciences
 *Herring, John L., University of Florida, Biology
 Hess, Seymour L., Florida State University, Physical Sciences
 Higginbotham, A. Curtis, Florida State University, Physiology
 Hinckley, Elmer D., University of Florida, Psychology
 Hobbs, H. H., Jr., Miller School of Biology, Charlottesville, Va., Zoology
 Holland, Ira H., Florida State University, Social Sciences
 Hood, Mary N., Florida State University, Bacteriology
 Horel, George, Box 1392, Lakeland, Fla., Biology
 Houston, Alfred, Box 590, St. Augustine, Law
 Hubbel, T. H., University of Michigan, Ann Arbor, Zoology
 Hubbs, Carl L., Scripps Institute of Oceanography, La Jolla, Calif., Zoology
 Huddle, H. B., University of Miami, Chemistry
 *Hudson, Joyce, Florida Southern College, Biological Sciences
 *Hughes, Evelyn, 2400 Ave. S., NW, Winter Haven, Fla., Biological Sciences
 Hull, F. H., University of Florida, Agronomy

Humm, Harold J., Florida State University, Marine Biology
Hunt, Burton P., University of Miami, Zoology
Hunt, Harry G., 7232 Linda Dr., Jacksonville, Chemistry
Hunter, F. R., Florida State University, Physiology
Huntley, Ralph, 310 Concord Dr., Fern Park, Fla., Physics
Hussey, Roland F., University of Florida, Biology

Idyll, Clarence P., Marine Lab., University of Miami, Marine Zoology
Ireland, Joseph C., Florida Southern College, Biological Sciences

*Jackson, Curtis R., 2837 Iroquois, Jacksonville, Botany
Jaggi, Martin P., University of Florida, Biology & Physical Sciences
*Jenkins, Leeman, Box 147, Florida Southern College, Biological Sciences
Johnson, Robert P., 3607 St. Charles Ave., New Orleans, Biological Sciences
Johnston, Helen, Oak Ridge Lab., Oak Ridge, Tenn., Biological Sciences
Jones, E. Ruffin, University of Florida, Biology

*Kamm, Mary Lou, Florida State University, Biological Sciences
*Kauffman, George B., University of Florida, Physical Sciences
Keech, J. Maynard, 2453 Inagua Ave., Miami, Business
Kidd, A. L., Florida A. & M. College, Social Sciences
Kilby, John D., University of Florida, Biological Sciences
Killip, Ellsworth, Big Pine Inn, Summerland Key, Fla., Biology
Kilpatrick, Wylie, 707 NW 20th St., Gainesville, Economics
Kinsler, B. M., Box 1059, Eustis, Fla., Geology
Kiser, R. S., Florida Southern College, Biology
Klein, Michael, Box 120, Route 5, Gainesville, Cancer Research
Komarek, E. V., R.R. 3, Thomasville, Ga., Biology
Kovach, Eugene G., Sea Island, Ga., Chemistry
Krause, Henry, 511 W. Government St., Pensacola, Biology
Kurz, Herman, Florida State University, Botany

Lackey, James B., 1534 NW 7th Pl., Gainesville, Biological Sciences

Laessle, Albert M., University of Florida, Biology

Lagasse, F. S., 14 NE 10th St., Gainesville, Biological Sciences

Lamb, E. B., 5 Plaza Way, SW, Atlanta, Ga.

Landrum, Harry G., Box 355, Graceville, Fla., Botany

*Lanter, Walter S., Florida State University, Biological Sciences

Larson, Edward, VA Hospital, Coral Gables, Physical Sciences

Larson, Olga, Florida State University, Mathematics

Last, William P., 75 Martense St., Brooklyn, N. Y., Biological Sciences

Lauter, Werner, MR 2, Kirkwood, Gainesville, Pharmacy

Leake, James M., University of Florida, History & Political Science

Leavitt, Benjamin, University of Florida, Biology

Ledin, Bruce R., Subtropical Experiment Station, Homestead, Fla., Botany

Leffler, John, Florida State University, Chemistry

*Legerton, Edward, Box 2339, Lakeland, Physical Sciences

Leigh, W. Henry, University of Miami, Zoology

- Lesperance, J. P., University of Miami, Physical Sciences
 Lewton, Frederick, 1911 Englewood Rd., Winter Park, Fla., Biological Sciences
 Lipman, Aaron, 6140 SW 45th St., Miami, Sociology
 °Lockman, Betty Sue, Orange Court Hotel, Orlando, Biological and Physical Sciences
 Longstreet, Rupert J., Box 65-C, Route 2, Deland, Fla., Psychology
 Loucks, Kenneth W., Citrus Experiment Station, Lake Alfred, Plant Pathology
 Lovell, William V., Route 1, Box 243, Sanford, Fla., Physical Sciences
 Lowenstein, B. E., P. O. Box 1438, S. Miami, Biological Sciences
 Lutz, Nancy, Virginia TB Association, Richmond, Va., Botany
 Lyster, J. G., 516 Greenleaf Bldg., Jacksonville, Neurological Surgery
 Lynch, S. J., 29800 Newton Rd., Homestead, Fla., Subtropical Horticulture
- MacDowell, Charles H., 1300 College Point, Winter Park, Chemistry
 MacGowan, W. Leroy, 1561 Marion Ave., Tallahassee, Biology
 McKenzie, Doris, University of Miami, Biological Sciences
 McLane, William M., Welaka, Florida, Biological Sciences
 Madsen, Grace C., Florida State University, Botany
 °Maines, Ray, Box 275, Bushnell, Fla.
 Mann, Chester A., 122 Ave. C., NE, Winter Haven, Biological Sciences
 Manzi, Mrs. Joseph A., Millbrook, N. Y.
 Marlow, Guy, Box 252, Bushnell, Fla., Biological Sciences
 °Marlowe, James M., 417 E. McDonald St., Lakeland, Biological Sciences
 Marshall, Nelson, Florida State University, Biological Sciences
 °Martin, Bobby E., Route 1, Box 781, Winter Haven, Biological Sciences
 Martin, Julia M., Florida A. & M. College, Chemistry
 Melvin, M. Avramy, 608 W. Call St., Tallahassee, Physical Sciences
 Merrill, Mrs. Frank, 1504 River Hills Circle, Jacksonville, Physical Sciences
 Metz, Charles B., Florida State University, Zoology
 Meyer, S. L., Florida State University, Botany
 Michelson, Edward H., Harvard University, Cambridge, Mass., Biology
 Miller, Dennis E., 71 Fairview Ave., Box 998, Ormond Beach, Biology
 Miller, E. Morton, University of Miami, Zoology
 Mills, Alfred P., University of Miami, Chemistry
 °Mitchell, Robert W., Box 236, Florida Southern College, Biological Sciences
 °Moody, Iona, Florida State University, Biological Sciences
 Moody, Harold L., c/o Florida Anglers Resort, Tavares, Fla., Biology
 Moore, Joseph C., Everglades National Park, Homestead, Biology
 °Morgan, William H., 301 S. Grove Lane, Panama City, Social Sciences
 Morrill, John B., Florida State University, Biological Sciences
 °Morris, Jon L., Florida Southern College, Biology
 Morse, Jerome G., University of Miami, Chemistry
 Morse, Marian, Palm Beach Jr. College, History & Psychology
 Morton, Mrs. Julia, University of Miami
 Morton, Kendal, University of Miami
 Morton, Richard L., William and Mary College, Williamsburg, Va.
 Mowry, Harold, Apartado 1649, San Jose, Costa Rica, Horticulture
 Mozingo, Hugh Nelson, Florida Southern College, Biology

- °Mulson, Joseph, Box 128, Longwood, Fla., Physical Sciences
 Murray, Mary Ruth, 1326 SW 1st St., Miami, General Sciences
 Mustard, Margaret, 4170 Ventura Ave., Coconut Grove, Bio-Chemistry
 Myrick, Mrs. Ida, 703 N. Adams St., Tallahassee, Chemistry
- Nance, E. C., President, University of Tampa
- °Nathurst, Hugh Lee, Florida Southern College, Biological Sciences
- °Newell, Elaine, Route 1, Cantonment, Fla., Physical Sciences
- °Nez, Martha M., Florida State University
 Nielsen, C. S., Florida State University, Botany
 Nielsen, E. T., Box 308, Vero Beach, Biological Sciences
- Odum, Howard T., University of Florida, Biology
- °Oetjer, Leroy, Box 66, Leesburg
 Oglesby, Woodson R., Jr., 541 N. Broadway, Shawnee, Okla., Geology
 Oliver, James A., New York Zoological Society, New York City, Biology
- °Oliver, James H., Fla. State University, Biological Sciences
 Olson, F. C. W., Florida State University, Oceanography
 Oroshnik, Jesse, 3515 Chesapeake Ave., Hampton, Va., Physical Sciences
- °Page, Elizabeth, 16 Columbia Way, Lakeland, Biological Sciences
 Page, Ralph E., University of Florida, Social Sciences
 Parker, Garald, U. S. Geological Survey, Washington, D. C., Geology
 Pates, Anne L., Florida State University, Bacteriology
 Pearson, Jay F. W., President, University of Miami, Zoology
 Pearson, Paul G., University of Florida, Biology
 Perry, Lynn, 1924 Ferdinand St., Coral Gables, Physical Sciences
 Phelps, Isaac K., Rollins College, Chemistry
 Phinizy, Thomas B., Florida State University, Biological Sciences
 Phipps, Cecil G., 1106 SW 5th Ave., Gainesville, Mathematics
 Pierce, E. Lowe, University of Florida, Biology
 Pierson, William H., University of Florida, Geography
 Pollard, C. H., University of Florida, Chemistry
 Pomeroy, Lawrence, Oyster Research Lab., Bivalve, N. J.
 Popper, Annie, Florida State University, History
 Powell, Robert D., University of Florida, Botany
- °Powella, Emma Rita, Route 4, Box 505, Lakeland, Biological Sciences
 Prichard, Elmer G., 605 N. Amelia, Deland, Biology
- °Prouty, Charles, 923 E. Lexington St., Lakeland, Biological Sciences
 Rabkin, Samuel, 511 Sylvan Drive., Winter Park, Dentistry
 Rainwater, Clarence S., University of Miami, Physics
 Rappenecker, Caspar, University of Florida, Geology
 Ray, Francis E., University of Florida, Cancer Research
 Reddick, Donald, R. D. No. 5, Box 119, Gainesville, Biological Sciences
 Reed, Clyde T., University of Tampa, Biology
- °Reese, William D., Florida State University, Biological Sciences
 Rehmund, John C., 23 N. 10th St., Haines City, Fla., Social Sciences
 Reid, George K., Jr., 108 Kyle St., College Station, Texas, Zoology

- Reinsch, B. P., Florida Southern College, Mathematics & Physics
 Reitz, J. Wayne, University of Florida, Biology
 Rethlingshafer, Dorothy, University of Florida, Psychology
 °Rewis, Carlton, 122 E. Park St., Lakeland, Biological Sciences
 Reynolds, Ernest, University of Miami, Botany
 Reynolds, J. Paul, Florida State University, Zoology
 Rhaney, Mahlon C., Florida A. & M. College, Biology
 Rich, Charles E., Route 2, Box 335-H, Pensacola, Physical Sciences
 Richards, Harold F., Florida State University, Physics
 Richardson, James G., University of Florida, Social Sciences
 Riley, J. W., Florida A. & M. College, Social Sciences
 Rivas, Luis Rene, University of Miami, Marine Zoology
 °Roberts, Estella, Box 3, Florida Southern College, Biological Sciences
 Roberts, Leonidas H., University of Florida, Physical Sciences
 Robertson, Harry S., University of Miami, Physics
 Rogers, Robert W., Florida State University, Zoology
 Rogosa, George L., Florida State University, Physics
 Rolfs, Clarissa, Colegio Americano, 71 Porto Alegre, Rio Grande de Sul, Brasil
 Ross, John S., Rollins College, Physics
 °Rufh, Chester E., 45 6th St., Campbell, Ohio
- Sanders, D. A., University of Florida, Biology
 Sanders, Murray, M.D., University of Miami, Microbiology
 Saunders, Dorothy C., University of Florida, Biological Sciences
 Saute, George, Rollins College, Mathematics
 Sawyer, Earl M., University of Florida, Physics
 Scanlon, Sister M. Elaine, Barry College, Miami, Social Sciences
 Schrader, H. W., 1636 NW 7th Ave., Gainesville, Physics
 Schubart, Frederick C., University of Tampa, Chemistry & Physical Sciences
 Schultz, Harry P., University of Miami, Chemistry
 Schwarz, Guenter, Florida State University, Physics
 Scott, Col. Bruce von G., USAF, ret., 5836 SW 25th St., Miami, Physical Sciences
 Scudder, Delton L., University of Florida, Social Sciences
 Selig, Max J., 120 S. Kentucky Ave., Lakeland, Social Sciences
 Senn, P. H., University of Florida, Biology
 Sherman, H. B., University of Florida, Biology-Mammals
 Shippy, W. B., Route 1, Box 73, Sanford, Plant Pathology
 Shores, Venila L., Florida State University, History
 Short, Robert B., Florida State University, Zoology
 Shuttleworth, F. S., University of Miami, Botany
 Sickels, Jackson P., 541 San Esteban Ave., Coral Gables, Physical Sciences
 Singeltary, Mary L., 122 Emmett St., Kissimmee, Biological Sciences
 Sleight, Frederick W., Box 94, Mount Dora, Physical, Social Sciences
 Sleight, Virgil G., University of Miami, Geology
 Smith, Alex, University of Florida, Physics
 Smith, Charles U., Florida A. & M. College, Social Sciences
 Smith, Earl D., 2309 Coventry Ave., Lakeland, Chemistry

- Smith, Frederick B., University of Florida, Microbiology
Smith, F. G., University of Miami, Marine Fisheries
Smith, Marshall E., M.D., 418 W. Platt St., Tampa, Chemistry
Smith, Reynolds B., University of Florida, Forestry
°Smith, Tim Murphy, Florida State University, Biological Sciences
Smyth, J. Adger, Florida State University, Marine Biology
Sokoloff, Boris, Florida Southern College, Biology
Soret, M. G., University of Miami, Microbiology
Soule, Mortimer J., 213 E. Bldg., Gainesville, Botany
Spivey, Ludd M., Florida Southern College, Sociology
Springer, Stewart, P. O. Box 185, Pascagoula, Miss., Biology
Steinbach, Warren H., 5834 SW 32nd St., Miami, Chemistry
Stevenson, Henry M., Florida State University, Ornithology
Stickler, W. Hugh, Florida State University, Biology
Stifler, Mrs. Cloyd B., 315 16th St., Bradenton, Botany
°Stinson, Walter S., Route 4, Box 1263, Lakeland, Biological Sciences
Stoddard, Herbert L., Sherwood Plantation, Thomasville, Ga., Biology
°Stoddard, Miss Jackie, 305 Coronado Dr., Clearwater Beach, Biological Sciences
Stoye, Frederick H., 604 Rosemont St., La Jolla, Calif., Biology
Streltsov, Leo A., Box 32, Florida Southern College, Physical Science
°Strickland, Mitchell R., University of Florida, Physical Sciences
Strohecker, H. F., University of Miami, Zoology
Stubbs, Sidney A., P. O. Box 722, Houston, Texas, Geology
Surrency, Winder H., 3600 Bay Shore Dr., Sarasota, Law
Swanson, D. C., University of Florida, Physics
Swindell, David E., Jr., Game & Fresh Water Fish Commission, Newport, Biological Sciences
- Tanner, W. Lee, Box 17, Panasoffee, Chemistry
Taylor, H. M., 111 N. Adams St., Jacksonville, Otolaryngology
Tchakarín, H. H., Box 463, Coral Gables
Tebeau, Carl P., University of Miami, Chemistry
Tebeau, C. W., University of Miami, History
Teller, Morton H., University of Florida, Curator
Terry, Ruth F., 127 E. Belvedere, Lakeland, Physical Sciences
°Theuer, Bert, University of Florida
Thomas, Dan A., 1335 Mayfield Ave., Winter Park, Physical Sciences
Thompson, Donald A., 4363 S. Lamon, Chicago, Social Sciences
°Thompson, Eunice, Florida State University, Biological Sciences
Thrift, Charles T., Florida Southern College, Social Sciences
Tiedtke, John, Rollins College
Tinner, J. C., Florida A. & M. College, Physical Sciences
Tisdale, W. B., University of Florida, Botany
Tissot, A. N., University of Florida, Entomology
Totten, Henry R., University of N. C., Botany
Toulmin, Lyman D., LSU, Baton Rouge, La., Geology
Twenhofel, W. H., Route 3, Orlando, Geology

- Vaughen, John V., 547 W. New York Ave., Deland, Chemistry
 Venning, Frank D., University of Miami, Botany
 Vestal, Paul A., Rollins College, Botany
 *Vihler, Jerry G., Box 212, Windermere, Fla., Biological Sciences
- Wade, Thomas L., Florida State University, Mathematics
 Waite, Alexander, Rollins College, Psychology
 Wallace, Harold E., Florida Southern College, Biological Sciences
 Wallace, Howard K., University of Florida, Biology
 Walsh, Sister Thomas Mary, Barry College, Miami, Biology
 Ware, Ethan E., Florida A. & M. College, Biological Sciences
 Wass, Marvin L., Mullet Key Marine Museum, Pass-A-Grille, Biological Sciences
- Watkins, Marshall O., University of Florida, Soils
 Weber, George F., University of Florida, Biology
 Week, Gertrude P., 629 W. Jefferson St., Tallahassee
 Weiss, Dr. A. Kurt, School of Medicine, University of Miami
 West, Erdman, University of Florida, Botany
 West, Frances L., St. Petersburg Junior College, Biology
 Westfall, Minter J., University of Florida, Biology
 White, Sarah P., 186 Marlborough St., Boston, Medicine
 *Wilhelm, Daniel A., 10 NE 3rd St., Ft. Lauderdale, Biological Sciences
 *Wilkinson, David, 235 3rd Ave., S., St. Petersburg, Physical Sciences
 Williams, H. Franklin, University of Miami, History
 *Williams, John W., Jr., 24 Lake Hollingsworth Dr., Lakeland, Biological Sciences
- Williams, Louise Ione, Lakeland High School, Biology
 Williams, Robert H., University of Miami, Marine Botany
 Williamson, B. F., Box 17, Gainesville, Tung Oil
 Williamson, R. C., University of Florida, Physics
 Wilson, Druid, U. S. Geological Survey, Washington, D. C., Paleontology
 Wilson, Roy A., Rollins College, Physical Sciences
 Wilson, W. Harold, Box 2227 University Station, Gainesville, Mathematics
 Winchester, A. M., Stetson University, Biology
 *Wind, Henry, 610 E. Amelia, Tampa
 Winnie, W. W., Jr., Box 3505 University Station, Gainesville, Social Sciences
 Winsor, Herbert, Box 2847 University Station, Gainesville, Soil Chemistry
 Winters, H. H., Florida Geological Survey, Tallahassee, Biological & Physical Sciences
- *Wise, David Jr., P. O. Box 455, University Branch, Coral Gables, Physical Sciences
- Wolfenbarger, Dr. Daniel, Sub-Tropical Experiment Station, Homestead, Biological Sciences
- Wood, F. G., Jr., Marine Studios, Marineland, Biology
 *Woodard, Jack, Route 1, Box 2, Leesburg
 Wright, A. Gilbert, Florida State Museum, Gainesville, Biological, Physical & Social Sciences
 Wynn, Mark F., 2716 SW 33rd Court, Miami, Biology

- Yates, Bernard, 901 William-Oliver Bldg., Atlanta
Yerger, Ralph W., Florida State University, Zoology
Yoho, Herbert, University of Florida, Geology
Yothers, W. W., 457 Boone St., Orlando, Entomology
Young, Frank N., University of Indiana, Entomology
Young, Sadie G., Florida State University, Economics

Ziegler, Arthur W., 1606 Meridian Rd., Tallahassee, Botany

NEWS AND COMMENTS

The Council of the Academy has approved several important policy matters which should be called to the attention of the membership. These policies were motivated by a desire to make the Academy a live organization even between the annual meetings so it could better serve its membership. Furthermore, it is sincerely hoped that by these new or renewed features, as the case may be, the Academy will render a fruitful service to the people of Florida.

The first of these changes is the revival of the "News and Comments" section. It is hoped that the membership will assist the Editor by supplying pertinent information for publication in this section. Again motivated by the desire to serve Florida the News and Comments section will carry information about the field of resource-use education submitted by the Florida Resource-Use Educational Committee.

The second important new service rendered by the Academy to Florida is the radio program "The Academy Speaks." This will be a regular monthly 15-minute broadcast over a number of stations throughout the State. The Academy is going to present the results of pertinent research to the radio audience in a form suitable to that medium of communication. The initial broadcast will be over WRUF at 8:00 P.M. May 29, 1954, at which time a forum discussion on "Florida's Future" will be presented. At later dates other stations will carry the program.

The radio program, which will be distributed from the University of Florida in cooperation with radio station WRUF, is an *Academy* program and it is hoped that all institutions will participate in it. The University of Miami is already in harness with Dr. W. Henry Leigh being chairman of the local subcommittee. Dr. D. R. Dyer, OF-7, University of Florida, is chairman of the Radio Committee. Interested members should write to him concerning the program.

Scientists all over the country are showing an increasing interest in problems involved in education for science. At the Tampa meeting in 1951 the Academy manifested its interest in the matter in passing a resolution concerning education. This concern prompted the Council's decision to approve a panel discussion on the problems of "Science and Education" for the customary Thursday evening opening meeting. A special call will be made to the

members for papers dealing with the practical aspects of the teaching of the sciences.

The Secretary-Treasurer has worked diligently in the preparation of an up-to-date membership list which is published in this issue. This work focused sharp attention upon the necessity of increasing the membership of the Academy. Dr. J. C. Moore, president-elect, had been appointed as chairman of the Membership Committee. It is hoped that all members will assist him in his task by inviting at least one qualified person to become affiliated with the Academy. In this connection, it is hoped that collegiate membership will be increased too. In order to carry out this task, the Council authorized the appointment of a committee on collegiate membership. Any member interested in this work should contact the President.

We would also like to remind the members of the Academy that the JOURNAL has a section headed "Research Notes" for the publication of shorter articles.

INSTRUCTIONS FOR AUTHORS

Contributions to the JOURNAL may be in any of the fields of Sciences, by any member of the Academy. Contributions from non-members may be accepted by the Editors when the scope of the paper or the nature of the contents warrants acceptance in their opinion. Acceptance of papers will be determined by the amount and character of new information and the form in which it is presented. Articles must not duplicate, in any substantial way, material that is published elsewhere. Articles of excessive length, and those containing tabular material and/or engravings can be published only with the cooperation of the author. Manuscripts are examined by members of the Editorial Board or other competent critics.

MANUSCRIPT FORM.—(1) Typewrite material, using one side of paper only; (2) double space *all* material and leave liberal margins; (3) use 8½ x 11 inch paper of standard weight; (4) do not submit carbon copies; (5) place tables on separate pages; (6) footnotes should be avoided whenever possible; (7) titles should be short; (8) method of citation and bibliographic style must conform to JOURNAL style—see Volume 16, No. 1 and later issues; (9) a factual summary is recommended for longer papers.

ILLUSTRATIONS.—Photographs should be glossy prints of good contrast. All drawings should be made with India ink; plan linework and lettering for at least ½ reduction. Do not mark on the back of any photographs. Do not use typewritten legends on the face of drawings. Legends for charts, drawings, photographs, etc., should be provided on separate sheets. Articles dealing with physics, chemistry, mathematics and allied fields which contain equations and formulae requiring special treatment should include India ink drawings suitable for insertion in the JOURNAL.

PROOF.—Galley proof should be corrected and returned promptly. The original manuscript should be returned with galley proof. *Changes* in galley proof will be billed to the author. Unless specially requested page proof will not be sent to the author. *Abstracts* and *orders for reprints* should be sent to the editor along with corrected galley proof.

REPRINTS.—Reprints should be ordered when galley proof is returned. An order blank for this purpose accompanies the galley proof. The JOURNAL does not furnish any free reprints to the author. Payment for reprints will be made by the author directly to the printer.

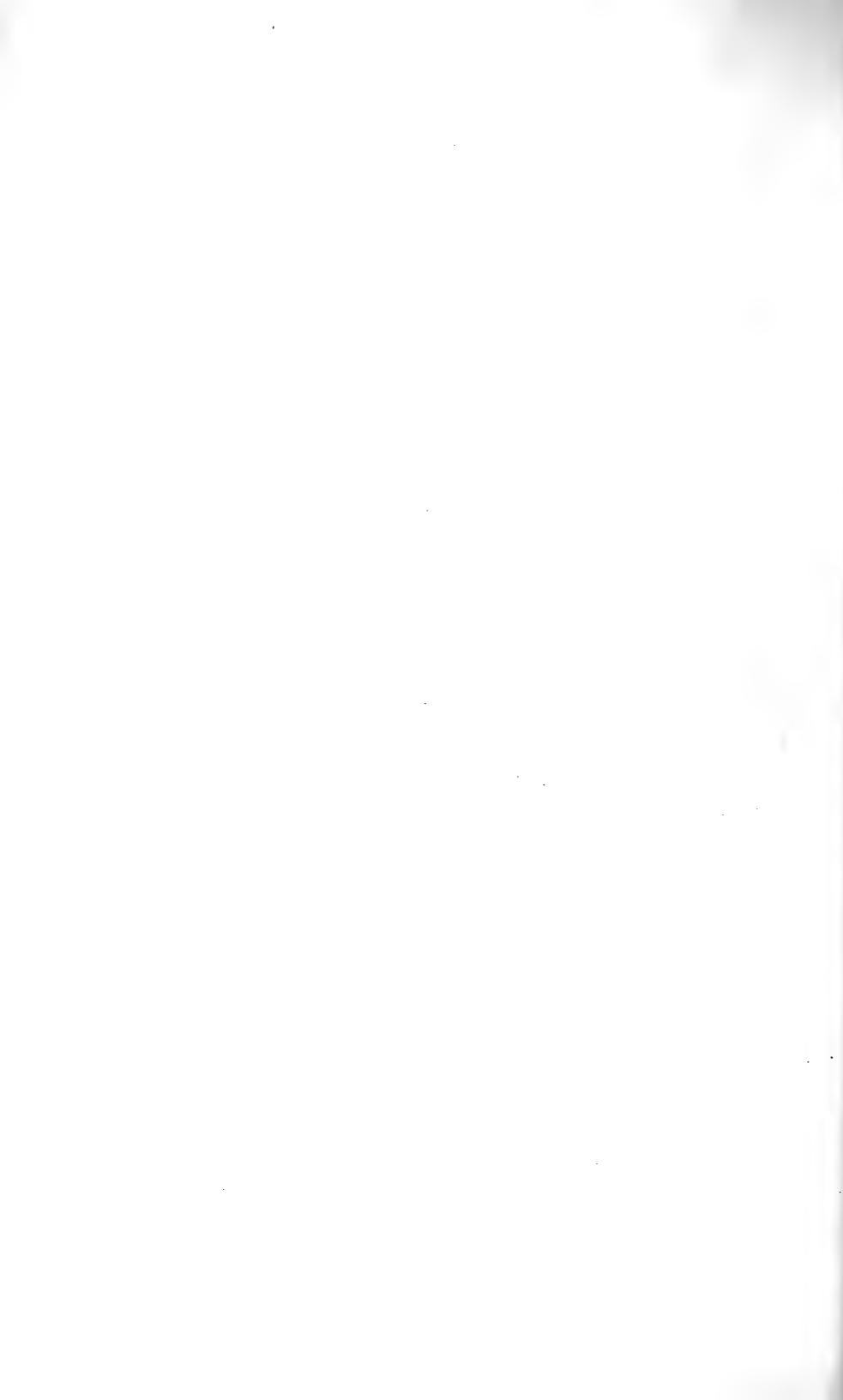

76F63

Quarterly Journal

of the

Florida Academy of Sciences

Vol. 17

June, 1954

No. 2

Contents

Becker—Florida's Resource-Use Education Problems	73
Nineteenth Annual Meeting of the Florida Academy of Sciences	82
Edson and Thornton—A Rapid Colorimetric Test for Organic Matter in Certain Mineral Soils	83
Nielsen—The Multitrichomate Oscillatoriaceae of Florida	87
Odum and Parrish—Boron in Florida Waters	105
Hobbs—A New Crayfish from the Upper Coastal Plain of Georgia (Decapoda, Astacidae)	110
Johnson—A Suggested Inorganic Fertilizer for Use in Brackish Water	119
News and Comments	128

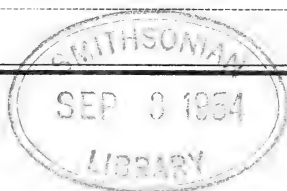



VOL. 17

JUNE, 1954

No. 2

QUARTERLY JOURNAL OF
THE FLORIDA ACADEMY OF SCIENCES

A Journal of Scientific Investigation and Research

Published by the Florida Academy of Sciences

Printed by the Pepper Printing Co., Gainesville, Fla.

The business offices of the JOURNAL are centralized at the University of Florida, Gainesville, Florida. Communications for the editor and all manuscripts should be addressed to H. K. Wallace, *Editor*, Department of Biology. All subsequent correspondence concerning manuscripts may be handled directly between authors and *associate editors*: J. C. Dickinson, Jr., *Biological Sciences*, Department of Biology and Florida State Museum; Donald R. Dyer, *Social Sciences*, Department of Geography; John W. Flowers, *Physical Sciences*, Department of Physics. Business communications should be addressed to R. A. Edwards, *Secretary-Treasurer*, Department of Geology. All exchanges and communications regarding exchanges should be addressed to The Gift and Exchange Section, University of Florida Libraries.

Subscription price, Five Dollars a year

Mailed August 18, 1954

THE QUARTERLY JOURNAL OF THE FLORIDA ACADEMY OF SCIENCES

VOL. 17

JUNE, 1954

No. 2

FLORIDA'S RESOURCE-USE EDUCATION PROBLEMS

HENRY F. BECKER
Florida State University

THE NEED FOR RESOURCE-USE EDUCATION

It has often been pointed out that the directives for education in any society can be discovered by consulting the needs of its people. A study of Florida reveals some interesting and highly significant facts indicative of such needs. A few of these are cited below.

Population. It is generally known that Florida's population is a growing one. During every decade since 1860 its rate of growth has exceeded that of the Southeast and of the Nation. Between 1930 and 1940 the total population of the state grew about 29 per cent. During the same period, however, 13 counties in the state *lost* people. Between 1940 and 1950 the state gained 46 per cent in population but 18 *counties lost people* (Figure 1). Sixteen of these 18 counties were in North Florida. Often those who leave are the vigorous, able young men and women seeking better economic opportunity elsewhere.

Income. Per capita effective buying income (gross income less individual income taxes) in Florida ranks above that of the rest of the Southeast but somewhat below the national level. In 1940 the average for Florida was \$475, that of the rest of the Southeast \$369, and that of the Nation \$692. In 1950 the Florida average was \$1131, that of the Southeast \$887, and that of the Nation \$1311. Within the state the average per capita income ranged from a low of \$90 to a high of \$688 in 1940; in 1950, from \$277 to \$1853. Low ranking counties were again concentrated in North Florida (Fig. 2).

Age of Population. North Florida obviously is poor as indicated above. And, as is usually the case with poor folks, families are

AUG 3 1 1954

large. Consequently, of the 36 counties with the highest percentage of their total population under 21 years of age, 34 are concentrated in a solid block in north and west Florida.

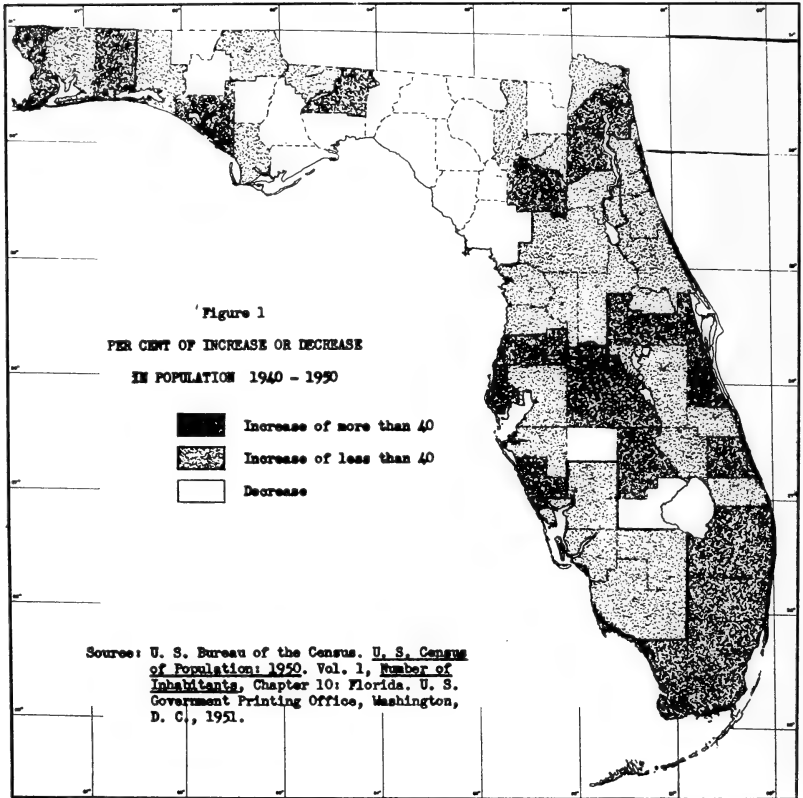

An Interpretation. These facts and many more, together with their implications and inter-relationships concerning not only Florida but also the Southeast, the Nation, and the world, are a necessary part of the equipment of a people concerned with creating a high level of civilization on an enduring basis. For example, behind the loss of people in certain North Florida counties for the last 10 to 30 or more years is a story of the misuse of a major natural resource—forests. In many parts of the Nation the destructive exploitation of forests was followed by farm settlement. Although all the answers are not yet in, it now appears to expert opinion

that close to two-thirds of Florida's land should be in trees, or possibly grass, rather than in farm lands. Going back to the North Florida counties that have been losing people, one sees that following the rapid removal of the forest cover to secure naval stores and lumber, both land and workers were abandoned by the companies operating under a "cut out and get out" policy.

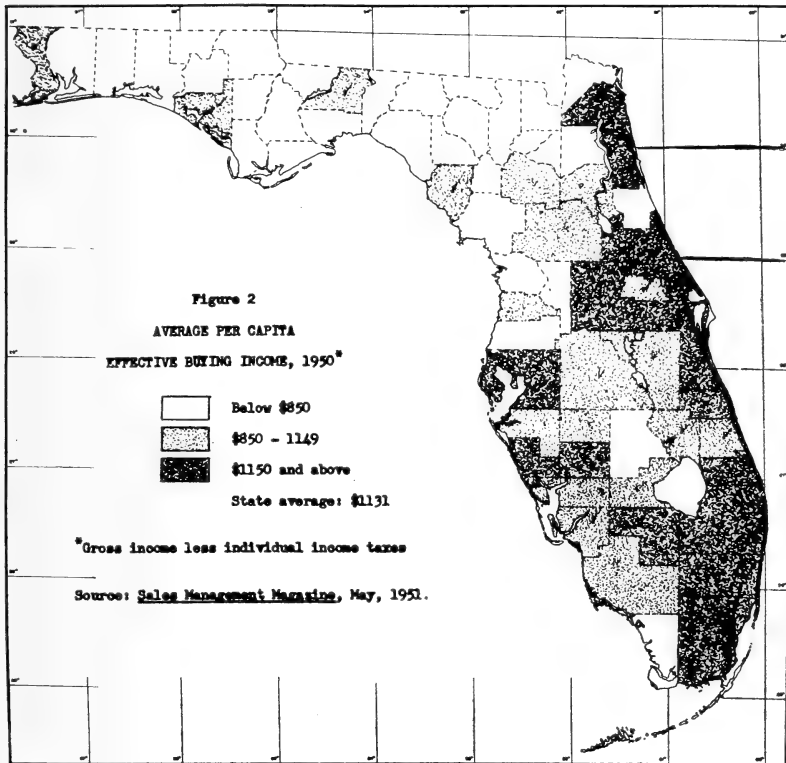

For the next 10 to 20 years, a stranded white population with neither skill nor capital tried to farm land unfit for crop production. About 20 years ago there were ten million acres of idle, cut-over, burned-over, tax-delinquent land in the state. Large areas of such land had grown up in scrub oak. Similar land in widely scattered areas of North Florida was in poor, unsuccessful farms, many of which have since been abandoned. In the ill-constructed houses on these farms it was often possible to "study geology through

the floor and astronomy through the roof." Counties whose major resource consisted of such land, soon found themselves unable to secure tax money with which to finance schools and other social services for their people. Thus they emerged as Florida's economic and educational problem number 1. It is significant that these counties are in the old part of the state; old enough to have gotten into trouble through misuse of resources. Let us hope that education can help the newer parts of the state avoid similar mistakes with reference to the use of water and other resources.

Fortunately the remedy for making misused forest lands productive again is at hand. Trees can grow faster in Florida than in any part of the United States. Florida has 5,000,000 acres of potential forest land on which trees will not re-seed themselves. Since 1928 only *4 out of every 100 of these acres* on which trees should be planted have been salvaged. At this rate it will take 500 years to complete the job. In 1948 there existed 17 per cent less timber in Florida than in 1934. If this rate of use continues, the end of Florida's timber supply would be reached in 92 years. These estimates, based on the recent biennial report of the Florida Board of Forestry, are said to be conservative (Florida Board of Forestry, 1950). Much of the ten million acres on delinquent land referred to above is still unproductive. Here is a resource-use education job that needs doing and which, if done would add millions of dollars of annual income in a relatively short time. Even more important than the money income would be the effect on the physical, mental, and spiritual health of people. Defeatism and loss of purpose thrive in communities where the economic struggle is unrewarded. Social institutions deteriorate and promising young people leave—which is where we started with this cycle. All of these trends could be reversed if everyone realized the need for reclaiming misused or unused land.

Summary of Needs. What is needed by all people is more knowledge and understanding of the gains that have been made and of the needs and problems still to be faced.

Florida's need for resource-use education is clearly of a two-fold character:

1. Those needs evidenced in more than twenty counties of North Florida and West Florida by problems common to the rural Southeast: the well-known problems of an older South which has ex-

ploited wastefully its best soils and its forests, a process which finally ended in numerous maladjustments in the use of natural resources and generally low levels of living for most of the people. These people are of southern origin and outlook, people from nearby states who came in search of new land and economic opportunity. Here, as in most of the rural Southeast, people have lived long enough on the land for the consequences of their mistakes to catch up with them. Hence this portion of the state shares with many parts of the South such common problems of poverty as poor health, poor housing, few modern conveniences, a high rate of natural increase, and inability to finance adequate schools and other institutions. Here all too frequently are insufficient economic opportunities and an out-migration of ambitious, able, and vigorous young people.

2. Those needs evidenced in the newer, more urbanized eastern, central, and southern parts of the state. Here in contrast to the general and subsistence farming areas of north and west Florida are the highly commercialized winter fruit and vegetable producing lands with their migratory workers and their early-season appeal to the high prices of northern markets. Here both urban and rural population are for the most part recent arrivals from northern and western as well as southern states, hence more cosmopolitan and possibly more sophisticated. Although these eastern, central, and southern parts of the state share to some extent the problems of north and west Florida, their difficulties stem largely from the fact of expanding, growing population still learning how to make use of resources in a subtropical environment different from that of the rest of the Southeast and the state. Here at first glance all seems to be well, but on probing beneath the facade of higher average incomes (Figure 2), larger number of better buildings, greater expenditures for schools, and larger amounts of taxable property, various problems emerge. Seasonal migration of population creates problems of education, of housing, of living costs, of temporary urban congestion, and of seasonal unemployment. Here are engendered the psychology of optimism based on catering to rich tourists who appear to come in endless streams, and the smugness which accompanies sudden and spectacular, if sometimes precarious, financial success. In short, here are the new parts of the State where the major problem might

well be defined as how to avoid the serious errors in use of resources that lead to trouble. Already there are evidences that it is high time to act to prevent serious water conservation problems from developing and to forestall soil depletion and the evils of over-drainage of wet lands. Already there are the problems of ill-housed and un-wanted migratory farm workers and of urban slums.

IMPLICATIONS FOR EDUCATION

In a democracy problems cannot be solved and human needs met by experts alone. It is essential also to have an enlightened public, understanding enough to support sound programs of resource-use. Hence, education must meet a four-fold need for:

A. Better-informed citizens of all ages who understand such basic assumptions as these (Becker and Brubaker, 1949):

1. The major short-term objective of a democratic society is the achievement of better living for more people; the major long-term objective, the best possible living for all people.
2. Any community (local, state, nation, world) is dependent for its living on its human, natural, and social resources. To continue permanently, a society must maintain all of its resources in productive condition.
3. The community loses when any resource is unused or mis-used.
4. The community suffers when resources are damaged, depleted, or destroyed. Mistreatment of resources threatens everybody's living level and must, therefore, be everybody's concern.
5. In nature undisturbed by man there is a delicate and easily upset balance among the various factors of the natural environment. It is so much easier to destroy this balance than to maintain it or to substitute a new one for it.
6. With intelligent use, renewable resources not too badly damaged can be restored to productive use. Wise use of resources helps to raise everybody's living level and must, therefore, be everybody's concern.
7. Cooperative effort in identifying and solving problems to secure group benefits is essentially democratic. Human be-

ings grow and develop through engaging in such a social process.

8. Failure to understand and act on all of the above assumptions creates numerous complex problems.

B. Specialists who can serve as foresters, soil conservationists, health officers, social workers, engineers, and the like, working directly with problems of resource-use.

C. Social scientists and scientists as library and field research workers to make available sound basic data and conclusions.

D. Translators and interpreters of research for use in education and action programs. This group may include persons from both groups above and, in addition, public administrators, journalists, newscasters, teachers, writers of textbooks, and many others. These people constitute a powerful force in American life. With the proper knowledge and understanding they can greatly accelerate the spread of needed facts and insights. It is here that one finds the big gap between what is known by research workers and what is used in educating school children, college students, and the public.

Obviously the educational job just outlined is of major proportions and will call for assistance from all agencies and institutions equipped to give aid. This is not a new educational panacea, but a re-focusing of educational effort upon a clearly defined goal. It involves not so much new courses at various levels as the re-assessment and re-pointing of practically all courses in science and social science now in the schools toward this goal.

FLORIDA'S RESOURCE-USE EDUCATION PROGRAM

Recognition by educational leaders of the kinds of problems described above resulted in a South-wide movement in what is now commonly called "resource-use education." Florida has participated in this movement since its inception.

Although several small beginnings had been made in resource-use education prior to 1943, Florida's program like many others in the south grew in large measure out of the Gatlinburg Conferences sponsored by the Committee on Southern Regional Studies and Education. In its November, 1943, meeting following the attendance of several Florida representatives at the first of these

Conferences, the Florida Courses-of-Study Committee adopted the following resolution:

The State Courses-of-Study Committee is convinced that there is a vital need for planning for the better utilization of all resources, both natural and human, in the State and believes that the schools can contribute materially to the attainment of this objective. This body strongly recommends that plans be developed for bringing about the necessary reorientation of the school program of the State and urges the State Department of Education to investigate all possibilities and secure a grant from the General Education Board, if possible, to assist in carrying out the projects.

On March 4, 1944, the Florida State Department of Education, on behalf of itself and the Florida State Planning Board, Florida State College for Women (now Florida State University), the University of Florida, and the Florida Agricultural and Mechanical College, made application to the General Education Board for financial assistance for a three-year program to be entitled "A Proposed Program for Improving Utilization of the Human and Natural Resources of Florida Through Education." This application was approved by the General Education Board and the program began to function on May 15, 1944, under the somewhat simpler title: "Florida Resource-Use Education Project." Financial assistance from the General Education Board was supplemented by funds and services from the sponsoring state agencies and institutions.

The Florida Program proceeded under the direction of a Coordinator, appointed by the State Superintendent of Education, and an Advisory Committee composed of one representative of each of the following institutions, agencies, and organizations:

- State Department of Education (two representatives, one for white public schools and one for Negro colleges and public schools)
- State Planning Board (abolished at the end of the first year of the program)
- Florida Courses of Study Committee
- Florida Teacher Education Advisory Council
- Florida Education Association
- Florida State College for Women (now Florida State University)
- University of Florida
- Florida Forest and Park Service

In addition to the agencies and institutions represented on the Advisory Committee, numerous others participated in the program. These included all teacher institutions in the state, both white and Negro, and various agencies such as the Florida Forest Service, the Florida Park Service, the Florida Geological Survey, the Florida

Game and Fresh Water Fish Commission, the Florida Department of Agriculture and Immigration, the Florida Advertising Commission, and the United States Soil Conservation Service. During Governor Caldwell's Administration this Committee was replaced by the Florida Resource-Use Education Committee referred to above.

The following aims and policies have guided the organization and administration of the program since its inception:

1. To develop and spread as widely as possible the point of view which forms the basis of an effective resource-use education program.
2. To attack the problems of resource use and resource-use education along as many fronts as possible.
3. To secure the active participation of as many agencies, institutions, groups, and individuals as possible.
4. To aid pre-service and in-service teachers to become better equipped to carry on resource-use education.
5. To make available needed new materials for the use of teachers and pupils.
6. To provide an adequate program for Negroes as well as for whites.

LITERATURE CITED

BECKER, HENRY F. and HARRY F. BRUBAKER

1949. A better living for Florida's people? *Jour. Fla. Educ. Assn.*, March, 1949.

FLORIDA BOARD OF FORESTRY

1950. *Eleventh Biennial Report*, Florida Forest Service, 1948-1950.

NINETEENTH ANNUAL MEETING
of
THE FLORIDA ACADEMY OF SCIENCES

DECEMBER 9, 10, 11, 1954
FLORIDA STATE UNIVERSITY
TALLAHASSEE, FLORIDA

Meetings will be held Thursday evening the 9th, Friday the 10th and Saturday morning the 11th of December, 1954. The formal call for papers will be issued and forms provided by the Secretary about October 1. These forms should be returned to the Section Chairmen by October 22 in order that the program may be mailed to the members about November 20.

With "Science and the Aims of Education" as the theme for the Thursday evening Symposium, the Council invites members to present papers concerned with the practical aspects of teaching science at the other sessions of this year's meeting.

A RAPID COLORIMETRIC TEST FOR ORGANIC MATTER IN CERTAIN MINERAL SOILS¹

SETON N. EDSON and GEORGE D. THORNTON²
University of Florida

It is generally agreed that the organic matter content of the soils of the Coastal Plains area is an important factor in determining their value for economic farming. Peech (1939) pointed out that the exchange capacity of these soil was largely dependent on the organic matter content. A light sandy soil, with less than 1.0 percent organic matter, is considered to be low in this component and is suitable for only limited types of agriculture. On the other hand, dark sandy soils with over 2 percent of organic matter are considered more desirable for many types of crops.

The color of a soil gives a rough estimate of its organic matter content; however, this may sometimes be misleading. The characteristic black color of organic matter in soils can be totally masked by iron stains, leading to an erroneous estimation of the organic matter content. Yet, farms are frequently bought and sold on the basis of the amount of black coloration present in the soil. A simple test for organic matter has long been needed as a tool for estimating more accurately the content of this constituent in soils.

The chromic acid procedure has been recognized as a standard method for determining soil organic matter (Merkle, 1940; Peech, Alexander, Dean and Reed, 1947; Purvis and Blume, 1941). However, none of these workers have succeeded in simplifying the procedure so that it can be useful as a rapid test for organic matter.

When the test is conducted in the conventional manner, it is time consuming and does not lend itself readily to the efforts of persons untrained in laboratory techniques. These limitations have been largely overcome by the development of a colorimetric method. This colorimetric method utilizes as a source of heat that of dilution of sulfuric acid when rapidly added to soil-chromic acid mixture. It also embraces the use of color standards, thus eliminating the tedious titration of the conventional method. The amount of organic matter oxidized by this procedure, up to 4.0 percent, is

¹ Florida Agricultural Experiment Station, Jour. Series, No. 240.

² Assistant Prof. of Soils, College of Agri. and Soil Microbiologist, Agr. Exp. Sta.

proportional to the amount of chromate reduced. As reduction takes place, the characteristic yellow color of the dichromate ion changes to chrome green. Change of color resulting from this method is correlated with soils of known organic matter content. A permanent set of reference solution colors are prepared which correspond with the changes of color of the reduced chromate ion when none-1-2-3- and 4-percent organic matter content are present. Such colors are conveniently mixed from acid solutions of copper sulfate and ferric chloride (Snell and Snell, 1950).

Only three test solutions, a small mortar and pestle, two small graduated cylinders, a single beam gram balance, an asbestos pad, and several 16 x 150 mm. test tubes are needed to make the colorimetric test described in this paper.

The chemical reaction taking place is vigorous and rapid, requiring only a few seconds to complete over 95 percent of the digestion. The remaining oxidation is completed on standing for a period of 20 minutes. It is important to have an asbestos pad under the cylinder when digestion is taking place in order to insure uniform cooling.

TEST SOLUTIONS

Concentrated sulfuric acid solution: Reagent grade H_2SO_4 .

2 N potassium dichromate solution: 98.08 gms. of reagent grade $\text{K}_2\text{Cr}_2\text{O}_7$ in distilled water diluted to 1 liter.

80% phosphoric acid solution: 800 ml. of H_3PO_4 in distilled water diluted to 1 liter.

2 N copper sulfate solution: 124.84 gms. of reagent grade $\text{CuSO}_4 \cdot 5\text{H}_2\text{O}$ in 1% HCl solution making total volume 1 liter.

2 N ferric chloride solution: 90 gms. of reagent grade $\text{FeCl}_3 \cdot 6\text{H}_2\text{O}$ in 1% HCl solution making total volume 1 liter.

REFERENCE STANDARDS

Soil samples from Alachua County, Florida, were used as a basis for the reference standards. These soils were collected by personnel of the United States Department of Agriculture and Florida Agricultural Experiment Station and analyzed for organic matter content in the laboratory by the conventional chromic acid method.

Tests by the rapid colorimetric method were conducted on these soils and permanent color reference solutions were prepared to correspond with the amounts of organic matter known to be present (Table I).

TABLE I

Known Soil Standards and Equivalent Permanent Color Reference Solutions

Soil Type	Depth of Soil	Known O. M. Content ^o	2 N CuSO ₄ .5H ₂ O	2 N FeCl ₃ .6H ₂ O	Organic Matter Rating
		%	ml.	ml.	%
Silica sand	None	None	15.0	0
Hernando f. s.	5"	1.18	0.5	15.0	1
Parkwood f. s. ...	5"	2.02	1.5	14.0	2
Fellowship f. s. ...	5"	3.10	5.5	10.0	3
Parkwood f. s. ...	4"	4.17	9.0	6.0	4

^o Recorded data from Soil Survey of Alachua County, Florida.

PROCEDURE

Since a representative soil sample is very important for reliable tests, approved soil sampling methods using a vertical cut to a depth of 6 inches were followed. Several sub-samples from the area were combined and the test sample drawn from the composite.

After screening the air dried soil through a 20-mesh sieve, a portion of the dry soil is ground in the mortar. One gram of the crushed soil is weighed and added to a 50 ml. graduate resting on an asbestos pad. With a dropping pipette 2.5 ml. of 2 N K₂Cr₂O₇ solution are added. Ten milliliters of concentrated H₂SO₄ are measured into a 25 ml. graduate and rapidly poured into the 50 ml. graduate containing the chromate and soil.

The soil is then allowed to digest for exactly twenty minutes. The colored supernatant liquid is poured to the 1.0 ml. mark on a 16 x 150 mm. test tube and followed by the 80 per cent H₃PO₄ solution added to the 5.0 ml. mark on the same test tube. Finally, the contents are mixed and the resultant color compared directly with the liquid color standards.

RESULTS

Results obtained for the determination of organic matter in Coastal Plains Soils are demonstrated by the data in Table II. A comparison is made with results obtained by the standard chromic acid procedure.

TABLE II

Comparative Values of Organic Matter Content of Some Typical Coastal Plains Soils by the Standard Chromic Acid and Rapid Colorimetric Methods.

Soil Type	Depth of Soil	Standard Chromic Acid* % O. M.	Rapid Colorimetric % O. M.
Scranton sand	6"	3.68	4.0
Greenville f. s.	6"	0.90**	1.0
Leon sand	5"	1.86	1.5
Ducker s. l.	6"	4.06**	4.0
Scranton f. s.	6"	3.90**	3.5
Gainesville l. f. s.	7"	2.42	2.5
Rex f. s.	8"	1.84	2.0
Plummer f. s.	8"	1.53	1.5

* Recorded data from Soil Survey of Alachua County, Florida.

** Recorded soils samples, College of Agriculture, University of Florida.

It will be noted in these data that fairly close agreement occurs between the two methods. In all cases the difference has been within 0.4 percent, a part of which may be attributed to the fact that two individual soil samples were involved.

LITERATURE CITED

MERKLE, F. G.

1940. Soil Testing—Operation, Interpretation and Application. Penn. State Agr. Exp. Sta. Bull. No. 398.

PEECH, M., L. T. ALEXANDER, L. A. DEAN and J. F. REED

1947. Methods of Soil-Fertility Investigations. U.S.D.A. Circ. No. 757.

PEECH, M.

1939. Chemical Studies on Soils from Florida Citrus Groves. Fla. Agr. Exp. Sta. Bull. No. 340.

PURVIS, E. R., and J. M. BLUME

1941. Truck Crops Investigation. Va. Truck Agr. Exp. Sta. Bull. No. 106.

SNELL, F. T., and C. T. SNELL

1950. Colorimetric Methods of Analysis. Vol. 1. Van Nostrand Co., New York, N. Y.

Quart. Journ. Fla. Acad. Sci. 17(2), 1954.

THE MULTITRICHOMATE OSCILLATORIACEAE
OF FLORIDA

C. S. NIELSEN
Florida State University

Continued from Vol. 17, No. 1

2. *Porphyrosiphon* Kützing ex Gomont.

Filaments simple. Sheaths purple or peach-colored. Trichomes solitary—few within sheath; apical cell never capitate.

A Trichomes never constricted at cross-walls, 4-6.6 μ wide, apical cells rotund or subconical. 1. *P. fuscus*

AA Trichomes generally constricted at cross-walls, 8-19 μ wide. Apical cell attenuate-obtuse. 2. *P. Notarisii*

1. *Porphyrosiphon fuscus* Gomont apud. Frémy. Mus. d'Hist. Nat. Bull. 33: 115 (1927).

Stratum thin, dark to black. Filaments variously curved and densely intricate. Sheaths firm, moderately wide, hyaline to often brownish-purple (in dried specimens), apex generally contracted, turning blue with chlor-zinc-iodine. Trichomes blue-green, never constricted at cross-walls, often moving out of sheath, 4-6.6 μ wide; cells most often longer than trichome diameter, 4.4 to 9 μ long, filled with indistinct protoplasmic granules. Apical cell rotund or subconical.

Collier county: Marco Island, *Paul C. Standley* 92839, 14 Mar. 1946 (C). Escambia county: freshwater pool behind dunes, Gulf beach, *Drouet, Nielsen, Madsen & Crowson* 10532, 10533, 8 Jan. 1949 (C, F). Jackson county: wayside park, U. S. highway no. 90, 1 mile west of Cottondale, *Drouet & Nielsen* 854, 19 Feb. 1949 (C, F). Jefferson county: Judge Hopkin's camp, Lake Miccosukee, *Nielsen & Crowson* 967, 11 Mar. 1949 (C, F). Lee county: Bonita beach, *Paul C. Standley* 92789, 10 Mar. 1946 (C). Monroe county: Cudjoe key, *Lawrence B. Isham* 6, 1952 (C). Santa Rosa county: in a depression in sand dunes, Pensacola beach, *Drouet, Nielsen, Madsen, Crowson & Pates* 10573, 8 Jan. 1949 (C, F). Wakulla county: on high eroded east bank of East river, west of St. Marks lighthouse, on the Gulf of Mexico at the mouth of St. Marks river, *Drouet, Madsen & Crowson* 11739, 2 Jan. 1949 (C, F).

P. fuscus Gom. has been found with *Porphyrosiphon Notarisii* Gom., *Scytonema figuratum* B. & F. and *Schizothrix longiarticulata* Gardn. It was reported for the state by Madsen & Nielsen (1950).

2. *Porphyrosiphon Notarisii* Gomont. Monogr. Oscill. p. 331, pl. 12, f. 1-2 (1892).

Stratum expanded, tomentose, dark purple. Filaments diversely curved and densely intricate. Sheaths purple, apex often hyaline, sometimes forming discolored layers, internally colored, externally hyaline, firm, finally very wide and exceedingly lamellose, apices acuminate and fibrillose, turning blue with chlor-zinc-iodine. Trichomes blue-green, generally constricted at crosswalls, 8-19 μ wide; cell length equal to or to 3 times as short as trichome diameter, 4.5-12 μ long, filled with protoplasmic granules; apical cell attenuate-obtuse.

Florida: W. C. Sturgis (C); J. D. Smith, Mar. 1878 (C, N, P). Alachua county: on ground in sandy places, Gainesville, *Ravenel* 5, 7, 20, 29, 1875 (C, H, N.Y., P). Bay county: in depression in sand, pine woods beside U. S. highway no. 319, 5 miles north-west of Beacon Hill, *Drouet & Nielsen* 11632, 31 Jan. 1949 (C, F). Franklin county: on debris, washed up on sand dunes, west side of Eastpoint, *Drouet & Nielsen* 11658, 11665, 11666, 31 Jan. 1949 (C, F). Gadsden county: Apalachicola river at Chattahoochee, *Nielsen, Madsen & Crowson* 293, 31 Aug. 1948 (C, F); barren ground in upland woods, beside U. S. highway no. 90, 4 miles east of Quincy, *Drouet, Nielsen, Madsen & Crowson* 10425 b, 10431, 4 Jan. 1949 (C, F); Apalachicola river flood plain, U. S. highway no. 90, Chattahoochee, *Nielsen* 1433, 1440, 1441, 1443, 9 July 1949 (C, F). Gulf county: among grasses on low sand dunes, shore of Gulf of Mexico, southeast of Beacon Hill, *Drouet & Nielsen* 10853, 10856, 14 Jan. 1949 (C, F). Jackson county: on barren red clay banks beside U. S. highway no. 90, 5 miles east of Marianna, *Drouet, Nielsen, Madsen & Crowson* 10339, 4 Jan. 1949 (C, F); on sand, 3 miles east of Marianna on U. S. highway no. 90, *D. Blake* 1, 2, 28 July 1952 (C, F). Lake county: on dry sand, Eustis, *R. Thaxter*, 1897 (D). Lee county: on log, region of Hendry creek, about 10 miles south of Fort Myers, *Paul C. Standley* 73183, 73200, 73234, 73269, 73454, 11-25 Mar. 1940 (C). Leon county: on clay bank near Ochlockonee river, U. S. highway no. 90, west of Stephensville, *Drouet, Crowson & J. Petersen* 10481, 6 Jan. 1949 (C, F); on clay bank beside Meridian road between Lake Iamonia and Ochlockonee river,

Drouet, Kurz & Nielsen 11261 b, 24 Jan. 1949 (C, F); in old field by magnolia woods, west of Lake Iamonia, *Drouet, Kurz & Nielsen 11277, 11279*, 24 Jan. 1949 (C, F); barren ground in a fallow field near north-west shore of Lake Iamonia, *Drouet, Kurz & Nielsen 11280, 11281*, 24 Jan. 1949 (C, F); barren ground in Blue Sink, a sink-hole in limestone beside state highway no. 61 (175) about 8 miles south of Tallahassee, *Drouet, Nielsen, Madsen, Crowson & Atwood 11575, 11576*, 29 Jan. 1949 (C, F). Levy county: upland and barrens in north-west part of Way key, Cedar Keys, *Drouet & Nielsen 11169*, 22 Jan. 1949 (C, F); barren ground in sandy open woods beside state highway no. 20, 1 mile east of Sumner, *Drouet & Nielsen 11206*, 23 Jan. 1949 (C, F). Liberty county: Apalachicola river flood plain at Bristol, *Nielsen & Madsen 433*, Aug. 1948 (C, F). Nassau county: near Hilliard, *Paul C. Standley 92768*, 18 Mar. 1946 (C). Polk county: north of Lake Wales, *Paul C. Standley 92773*, 16 Mar. 1946 (C). Santa Rosa county: in depression and sand dunes, east of Pensacola beach, *Drouet, Nielsen, Madsen, Crowson & Pates 10573, 10583, 10596, 10599, 10609*, 8 Jan. 1949 (C, F). Taylor county: on bank of creek, U. S. highway no. 27, 1 mile north-west of Perry, *Drouet & Nielsen 10747*, 11 Jan. 1949 (C, F). Wakulla county: Spillway dam, Phillips lake, St. Marks wildlife refuge, *Nielsen & Madsen 704*, 5 Dec. 1948 (C, F). Washington county: dry ground, Falling Waters, 4 miles south of Chipley, *C. R. Jackson 1*, 14 Jan. 1951 (C, F); moist stream bank, Falling Waters, 4 miles south of Chipley, *C. R. Jackson 2*, 14 Jan. 1951 (C, F); *M. H. Voth*, 14 Jan. 1951 (C, F).

The alga may be found with *Microcoleus paludosus* Gom., *M. vaginatus* Gom., *Porphyrosiphon fuscus* Gom., *Schizothrix purpurascens* Gom., *S. longiarticulata* Gardn., *Scytonema figuratum* B. & F. *S. ocellatum* B. & F., *Stigonema panniforme* B. & F. and *Symploca Kieneri* Dr. The species has been reported for the state by Drouet (1939), Nielson & Madsen (1948b) and Crowson (1950).

3. *Hydrocoleum* Kützing ex Gomont.

Filaments forming more or less pseudo-branched caespitose cushions, very rarely lime-encrusted, or indefinite tufts, or strata phormidioid and never caespitose. Sheaths always hyaline, cylindrical, lamellose, more or less mucous, amorphous and becoming

entirely diffuent with age, never turning blue with chlor-zinc-iodine. Trichomes few within sheath, often loosely aggregated; cells shorter than trichome diameter, in several species extremely short; apex of trichome straight, more or less attenuate; capitate; membrane of apical cell thickened above into a calyptra. Plants aquatic, specifically marine.

Plants more or less green, never red, marine. Trichomes 8-24 μ wide; cells very short.

1. Trichomes 8-16 μ , generally 9-11 μ wide, conspicuously capitate, cells 2.5-4.5 μ long. 1. *H. lyngbyaceum*
2. Trichomes 9.5-14.3 μ , generally 11 μ wide, not conspicuously capitate, cells 1.9-3.8 μ long. 2. *H. penicillatum*
3. Stratum never caespitose, mucous, dark yellow to yellow-green. Sheaths amorphous or entirely diffuent. Trichomes 14-21 μ , generally 17-19 μ wide. 3. *H. glutinosum*
4. Stratum caespitose, green-violet. Sheaths cylindrical, moderately mucous. Trichomes 14-21 μ wide.

4. *H. comoides*

1. *Hydrocoleum lyngbyaceum* Gomont. Monogr. Oscill. p. 337, pl. 12, f. 8-10 (1892).

Plant mass tufted blackish-green broadly expanded mucous stratum. Filaments joined, bases simple, above numerous appressed pseudo-branches. Sheaths wide, mucous, eroded at margins, apices acuminate or often open, occasionally entirely diffuent and agglutinated. Trichomes yellowish-green, numerous at base of filaments and spirally intricate and contorted, solitary in branches, not constricted at cross-walls, 8-16 μ , generally 9-11 μ wide; cells 3 to 6 times shorter than diameter, 2.5-4.5 μ long; cross-walls granular; apex of trichomes attenuate-truncate.

Var. (*alpha*) *lyngbyaceum*. Caespitose, generally epiphytic; sheaths firm.

Var. *rupestre* Gom. Stratum expanded, mucous, sheaths entirely diffuent.

Florida: *Smith*, Mar. 1878 (after *Wolle*). Franklin county: forming conspicuous dark turf on barnacles, whistle buoy 26, 10 miles southeast of Alligator point, *H. J. Humm*, 27 July 1952 (C). Levy county: on pilings, municipal wharf, Way key, Cedar Keys, *Drouet & Nielsen 11122*, 22 Jan. 1949 (C, F). Monroe county: irregular & rounded masses on rocks, Key West, *Marshall A. Howe 1490*, 28 Oct. 1902 (C). Taylor county: Keaton's beach, *Madsen & Pates 1092*, 4 May 1949 (C, F).

The species has been reported for the state by Tilden (1910), by W. R. Taylor (1928) from Dry Tortugas, Drouet (1939), and Madsen & Nielsen (1950).

2. *Hydrocoleum penicillatum* Taylor. Bull. Torrey Bot. Club 56: 201, f. 1, 2 (1929).

Expanded stratum, little color, mucous but including calcareous sediment or partly calcified. Filaments in fascicles usually 3 cm. tall, or up to 5 cm. and 2.0 mm. in diameter, simple or with 1-10 main branches, mucous and pale below, above increasingly pilose with dark brown-violet filaments, the ends more or less penicillate and attenuate; trichomas 9.5-14.3 μ in diameter, cells 1.9-3.8 μ long; trichomes with depressed rounded calyptra and pale straw color to nearly colorless; trichomes hardly capitate, slightly tapered near the apex which is nearly straight, slightly constricted at cross-walls which are inconspicuously and rarely granulated; sheaths confluent, the individual ones hardly recognizable.

Monroe county: south shore near Battery and south of Old Fort, Key West, R. Thaxter, Feb. 1898 (C, H).

The species was originally described and reported for the state by W. R. Taylor (1929) from the 1898 Thaxter collection.

3. *Hydrocoleum glutinosum* Gomont. Monogr. Oscill. p. 339 (1892).

Stratum dark yellow or dark yellowish-green, never caespitose, mucous, indefinite expanse, or cylindrical thallus. Sheaths very irregular at margins and amorphous, occasionally entirely diffuent. Trichomes pale to dark green, not constricted at cross-walls 14 to 21 μ , generally 17-19 μ wide; cells 3 to 6 times shorter than diameter, 2.5-3.5 μ long; cross-walls granular; apex of trichome attenuate-truncate.

Var. *glutinosum*. Stratum phormidioid, amorphous, expanded.

Var. *vermiculare* Gom. Thallus elongate-cylindrical, pale or dark green.

Monroe county: Tortugas, F. W. Hooper, about 1850, (C). St. Johns county: north of bridge on west side of Anastasia island, St. Augustine, Madsen, Pates & S. Parker 2026, 2 Jan. 1950 (C, F).

4. *Hydrocoleum comoides* Gomont. Monogr. Oscill. p. 335, pl. 12, f. 3-5 (1892).

Plant mass pulvinate, hemispherical, green-violet, caespitose, mucous, up to one-half cm. high. Filaments erect, tortuously and often spirally intricate-contorted below, above free, straight, rarely branched. Sheaths ample, lyngbyaceous, regular at margins, smooth, insignificantly mucous, occasionally lamellose, and fibrillose, apices generally open. Trichomes blue-green, few within sheath, solitary in upper portion of filaments, con-

stricted at cross-walls in dried specimens, 14-21 μ wide; cells 3 to 7 times shorter than trichome diameter, 3-5 μ long; cross-walls granular; apex of trichome attenuate-truncate.

Monroe county: Tortugas, *F. W. Hooper*, about 1850 (C); walls of fort, Key West, *R. Thaxter*, 1898-99 (C); in small rounded or irregular cushion-shaped masses on rocks, Key West, *Marshall A. Howe* 1490, 28 Oct. 1902 (C); West Summerland key, *H. J. Humm* 3, 2 Jan. 1946 (C); surface of intertidal limestone, West Summerland key, Overseas highway, *H. J. Humm*, 27 Jan. 1946 (C). Pinellas county: on old oyster shells in intertidal zone near main bridge, Campbell causeway, Tampa bay, *Nelson Marshall*, 18 Jan. 1953 (C).

4. *Sirocoleum* Kützing ex Gomont.

Filaments elongate, caespitose, fruticulose, dichotomously branched. Sheaths firm or slightly diffuent, never colored, cylindrical, not lamellose, not turning blue with chlor-zinc-iodine. Trichomes numerous within sheath, often aggregated into many distinct fascicles; apex of trichome straight; apical cell conical, never capitate. Plants marine.

A Trichomes torulose, 4-5.5 μ wide; cells subquadrate, or longer than diameter. 1. *S. guyanense*

AA Trichomes not torulose, 7-10 μ wide; cells shorter than diameter. 2. *S. Kurzii*

1. *Sirocoleum guyanense* Gomont. Monogr. Oscill. p. 348, pl. 14, f. 1, 2 (1892).

Caespitose, thin, dark green or dark blue-green, up to 3 cm. high. Filaments dichotomous or fasciculate branching. Sheaths hyaline to dark yellow-green, wide agglutinated, repeated transverse corrugations and nearly squamous, not diffuent, apex closed and acuminate or open. Trichomes blue-green, few within sheath at the base of the filaments, above numerous, straight, parallel, never funiformly contorted, constricted at cross-walls, 4-5.5 μ wide; cells subquadrate to 3 times trichome diameter, 3.5-12 μ long, occasionally filled with large protoplasmic granules; cross-walls never granular; apical cell acute conical.

Collier county: Marco island, *Paul C. Standley* 92834, 14 Mar. 1946 (C). St. Johns county: on palmetto piers, *Marshall A. Howe* 1211, St. Augustine, 7 Oct. 1902 (C, D); on *Cladophora*, Key Largo, *Ruth Patrick Hodge* 2, 24 Nov. 1935 (D).

3. *Sirocoleum Kurzii* Gomont. Monogr. Oscill. p. 349, pl. 14, f. 3, 4 (1892).

Caespitose, penicillate, thin, waving, sometimes dark, other times brilliant green. Filaments pseudo-branched, false branches appressed. Sheath hyaline, mucous, wide, smooth on outside or rough and corrugate, apex closed and acuminate or open. Trichomes pale blue-green, or violet, parallel, straight or funiform contorted, apex acuminate, not constricted at cross-walls, 7-10 μ wide; cells 2 to 4 times shorter than diameter, 2-4 μ long; cross-walls frequently granular; apical cell obtuse conical.

St. Johns county: on palmetto piers, St. Augustine, *Marshall A. Howe*, 1211, 1213, 7 Oct. 1902 (D).

5. *Microcoleus* Desmazières ex Gomont.

Filaments simple or here and there pseudo-branched, creeping on substrate, occurring among other algae. Sheath hyaline, more or less regularly cylindrical, never lamellose, in many species finally becoming diffluent, turning blue with chlor-zinc-iodine in two of the listed species. Many trichomes developing in the filaments within sheath, firmly intricate, often funiform and contorted; apex of trichome straight, attenuate; apical cell acute, rarely obtuse conical, capitate in one species.

- A Apical cell capitate 1. *M. vaginatus*
- AA Apical cell not capitate B.
- B Apical cell acute-conical
 - 1. Trichomes constricted at cross-walls, 2.5-6 μ wide; cells subquadrate to twice the width. 2. *M. chthonoplastes*
 - 2. Trichomes constricted at cross-walls, 1.5-2 μ wide; cells to four times diameter in length. 3. *M. tenerrimus*
 - 3. Trichomes not constricted at cross-walls, 1.8-2.2 μ wide; cell length 2-4 times width. 4. *M. acutissimus*
- BB Apical cell obtuse-conical
 - 1. Sheaths somewhat mucous, not or scarcely diffluent. Trichomes not constricted at cross-walls, 5-7 μ wide. 5. *M. paludosus*
 - 2. Sheaths mucous, diffluent. Trichomes very constricted at cross-walls, 4-5 μ wide. 6. *M. lacustris*
 - 3. Sheaths hyaline, wide, often diffluent. Trichomes somewhat constricted at cross-walls, 3-4 μ wide. 7. *M. rupicola*

1. *Microcoleus vaginatus* Gomont. Monogr. Oscill. p. 355, pl. 14, f. 12 (1892).

Filaments creeping, dispersed, rarely matted, in black glistening stratum, tortuous, rarely ever in disorderly pseudo-branches. Sheaths cylindrical, more or less eroded at margins, agglutinated, apices acuminate and closed, or open and diffluent, occasionally entirely diffluent, not turning blue with chlor-zinc-iodine. Trichomes blue-green, numerous within sheath, firmly intricate, generally funiform-contorted, never constricted at cross-walls, apices long attenuate and capitate, 3.5-7 μ wide; cells subquadrate to one-half trichome diameter, rarely twice width, 3-7 μ long; cross-walls frequently granular; membrane of the apical cell thickened above into a depressed conical calyptra.

Var. *Vaucheri* Gomont. Trichomes 4.4-6.6 μ wide; cells subquadrate to half as short as diameter.

Var. *monticola* Gomont. Trichomes 3.5-4 μ wide; cell length frequently double the diameter.

Alachua county: Hibiscus Park, Gainesville, *Brannon 173, 189*, 11 May 1943 (C, U); *180*, 14 July 1943 (C); *183*, 17 July 1943 (C, U); *224, 225*, 4 Apr. 1944 (C, F); *217 a*, 20 Apr. 1944 (C, U); *229*, 12 May 1944 (C, U); *306*, 24 Aug. 1945 (C, U). Bay county: U. S. highway no. 319, 5 miles north-west of Beacon Hill, *Drouet & Nielsen 11637*, 31 Jan. 1949 (C, F). Gadsden county: U. S. highway no. 90, 4 miles east of Quincy, *Drouet, Nielsen, Madsen & Crowson 10413*, 4 Jan. 1949 (C, F). Jackson county: wayside park, 1 mile west of Cottondale, *Nielsen & Madsen 857*, 19 Feb. 1949 (C, F). Lee county: dried pool, region of Hendry creek, about 10 miles south of Fort Myers, *Paul S. Standley 73195*, 11-25 Mar. 1940 (C). Leon county: Oven's woods, Magnolia hts. Tallahassee, *Nielsen & Madsen 417*, Aug. 1948 (C, F); open woods, west of F.S.U. campus, *Drouet & Crowson 10447, 10448*, 5 Jan. 1949 (C, F); on soil near F.S.U. greenhouse, Tallahassee, *Drouet & Crowson 10456, 10458*, 5 Jan. 1949 (C, F); state highway no. 20, 19 miles west of Tallahassee, *Nielsen & Madsen 799*, 22 Jan. 1949 (C, F). Levy county: sandy open woods, state highway no. 20, 1 mile east of Sumner, *Drouet & Nielsen 11206*, 23 Jan. 1949 (C, F). St. Johns county: Hastings, *Brannon 294*, 28 Nov. 1947 (C). Wakulla county: wet bank, St. Marks river, Newport, *Drouet, Madsen & Crowson 10822*, 13 Jan. 1949 (C, F); sulfur spring, Newport, *Nielsen*, 23 July 1952 (C, F); sulfur spring, Newport, *C. E. Ruffh*, 23 July 1952 (C, F).

The filaments of some of the specimens examined were not closely entangled to form a stratum, but were commonly found with such

other algae as *Hassallia byssoidea* B. & F., *Microcoleus paludosus* Gom., *Phormidium tenue* Gom., *Porphyrosiphon Notarisii* Gom. and *Symploca Kieneri* Drouet. In others a stratum was formed, dark green to black in color. Trichome diameters averaged about 5 μ and cell length varied from 2.5-3.5 μ .

Drouet (1943) states that *M. vaginatus* along with species of *Schizothrix* and *Porphyrosiphon* forms a superficial crust wherever silt has collected and ground is barren. In depressions where water remains standing for some days after rains, the trichomes move out of the sheaths and form phormidioid masses which are often confused with *Phormidium autumnale* Gom. and *P. uncinatum* Gom. Where such strata become desiccated in a very short time, the filaments almost invariably contain a single trichome. The species has been reported for the state by Nielsen & Madsen (1948b) and Brannon (1952).

2. *Microcoleus chthonoplastes* Gomont. Monogr. Oscill. p. 353, pl. 14, f. 5-8 (1892).

Filaments forming a dark, blackish-green stratum, ragged, a long and broad compact expanse, stratified, strata discolored, or growing sparingly between other algae, tortuous, not often branched. Sheaths cylindrical, more or less irregular and eroded at the margins, apices generally open, occasionally entirely diffluent, not turning blue with chlor-zinc-iodine. Trichomes brilliant blue-green, short, straight, numerous within sheath, firmly aggregated into fascicles, generally acuminate apices, rarely funiform and contorted, constricted at cross-walls, 2.5-6 μ wide; cells subquadrate, or to twice the diameter in length, 3.6-10 μ long; cross-walls not granular; apical cell never capitate, acute conical.

Bay county: shore of St. Andrews bay, West bay, *Drouet & Nielsen 10858*, 15 Jan. 1949 (C, F). Broward county: tidal mudflat, Dania beach, *Drouet & Louderback 10278*, 28 Dec. 1948 (C, F); on drying ground beside intracoastal waterway between Dania beach and Hollywood beach, *Drouet & Louderback 10270*, 28 Dec. 1948 (C, F); tidal mud flat, mangrove swamp, south of South lake, Hollywood, *Drouet 10305, 10306*, 29 Dec. 1949 (C, F); wet sand, mangrove swamp, south of South lake, Hollywood, *Drouet 10311, 10313*, 29 Dec. 1949 (C, F). Collier county: dried pool, Marco Island, *Paul C. Standley 73396*, 19 Mar. 1940 (C). Flagler county: on intertidal rocks, Marineland, *H. J. Humm*, 6 June 1948 (F). Franklin county: intertidal, on palmetto stumps, Gulf of Mexico at Lanark,

Drouet & Nielsen 10852, 14 Jan. 1949 (C, F); intertidal, north shore of St. Vincent sound, 10 miles west of Apalachicola, *Drouet & Nielsen 10982, 10985*, 16 Jan. 1949 (C, F); intertidal, shore of Apalachicola bay, south-east Apalachicola, *Drouet & Nielsen 11005*, 16 Jan. 1949 (F); intertidal, shore of St. George sound, mouth of New river, *Carrabelle, Drouet & Nielsen 11676*, 31 Jan. 1949 (C, F). Lee county: on moist sand, region of Hendry creek, about 10 miles south of Fort Myers, *Paul C. Standley 73459*, 11-25 Mar. 1940 (C). Levy county: intertidal, shore of cove, northwest Way key, Cedar Keys, *Drouet & Nielsen, 11149, 11150, 11151, 11157, 11160*, 22 Jan. 1949 (C, F); wood work, bridge between mainland and Way key; Cedar Keys, *Drouet & Nielsen 11180*, 22 Jan. 1949 (C, F); intertidal on pilings, east end of bridge between mainland and Way key, Cedar Keys, *Drouet & Nielsen 11184a*, 22 Jan. 1949 (C, F); intertidal mud on shore opposite municipal wharf, Way key, *Drouet & Nielsen 11185*, 22 Jan. 1949 (C, F). Monroe county: Cocanut Grove, *R. Thaxter*, 1898-99 (D); barren ground along shore near Big Pine Inn, Big Pine key, *M. Alice Cornman*, 2 May 1943 (C); in shallow water on ocean side of Key Largo, Tavernier, *H. J. Humm*, 30 Aug. 1950 (C); saline flats, south of Big Pine Inn, Big Pine key, *E. P. Killip & J. Francis Macbride*, Apr. 1951 (C); Big Pine key, *E. P. Killip 41683*, 9 Jan. 1952 (C); *41808*, 22 Jan. 1952 (C); *41850*, 29 Jan. 1952 (C); *41857*, 31 Jan. 1952 (C); *41967*, 18 Mar. 1952 (C); *42018*, 19 Mar. 1952 (C); *42073*, 29 Mar. 1952 (C); West Summerland key, *Lawrence B. Isham 4, 10*, 1 Oct. 1952 (C); Cudjoe key, *Isham 7*, 1 Oct. 1952 (C); Indian key, *Isham 5, 29, 30 Nov. 1952*. (C). Palm Beach county: on stones at sewer outlet, Lake Worth Flagler memorial bridge, Palm Beach, *Drouet & Louderback 10218*, 24 Dec. 1948 (C, F). Taylor county: intertidal, confluence of Daughter creek and Steinhatchee river, Steinhatchee, *Drouet & Nielsen 11217, 11220, 11221, 11221a, 11225*, 23 Jan. 1949 (C, F); intertidal, shore of Steinhatchee river, south Steinhatchee, *Drouet & Nielsen 11230, 11233, 11234a*, 23 Jan. 1949 (C, F); mouth of Steinhatchee river, Steinhatchee, *Nielsen 2085, 2088*, 1 Apr. 1950 (F); Deckle beach, *Madsen, Pates, Higginbotham & Harris 1080, 1081, 1082*, 23 Apr. 1949 (C, F). Wakulla county: intertidal, shore of St. Marks river, Port Leon, *Drouet & E. M. Atwood 11439, 11441, 11445, 11446, 11447*, 26 Jan. 1949 (C, F); bank of East river, west of St. Marks lighthouse, Gulf of Mexico, *Drouet, Madsen & Crow-*

son 11728, 11749, 1 Feb. 1949 (C, F); jetties, St. Marks lighthouse, H. J. Harris, 25 Mar. 1950 (F); on rock, brackish stream along road, St. Marks wildlife refuge, Nielsen 1, 2, 3, 4, 5, 7, 4 Oct. 1951 (C, F); floor of channel, Shell Point, Gulf of Mexico, Nielsen 07, 7 Nov. 1952 (C, F).

The specimens examined above varied from 2.5 to 3.5 μ in trichome width, and from 4.5 to 7 μ in cell length. They were frequently found with the following algae: *Bostrychia* sp., *Entophysalis crustacea* (J. Ag.) Dr. & Daily, *Hydrocoleum* sp., *Lyngbya aestaurii* Gom., *L. semiplena* Gom., *Microcoleus tenerrimus* Gom., *Oscillatoria amphibia* Gom., *O. brevis* var. *neapolitana* Gom., *O. Corralinae*, Gom., *O. nigro-viridis* Gom.; *Scytonema ocellatum* B. & F., *Schizothrix* sp., *Symploca atlantica* Gom., *S. laeteviridis* Gom. and *Vaucheria* sp. The species has been reported for the state by W. R. Taylor (1929), Madsen & Nielsen (1950) and Humm 1952).

3. *Microcoleus tenerrimus* Gomont. Monogr. Oscill. p. 355, pl. 14, f. 9-11 (1892).

Filaments densely matted into a blue-grey to blue-green stratum or mixed with other algae, simple to sparingly pseudo-branched. Sheaths wide, irregular at margins, apices acuminate or open, occasionally entirely diffluent, not turning blue with chlor-zinc-iodine. Trichomes green-olive, more or less numerous within sheath, elongate, flexuous, generally loosely aggregated, very constricted at cross-walls, apices long attenuate, 1.5-2 μ wide; cells longer than wide, frequently 3 times the trichome diameter, 2.2-6 μ long; cross-walls clear, never granulate; apical cell never capitate, very acute conical.

Bay county: intertidal, St. Andrews bay at Panama City, on pilings and barnacles, Drouet & Nielsen 11609b, 11615, 30 Jan. 1949 (C, F). Duval county: pier pilings, 2 miles south of St. Johns river mouth, Jacksonville beach, H. J. Humm 4, 19 Mar. 1948 (C). Franklin county: intertidal, Gulf of Mexico at Lanark, shore and on palmetto stumps, Drouet & Nielsen 10848, 10852, 14 Jan. 1949 (C, F); intertidal, on docks in New river, Carrabelle, Drouet & Nielsen 10971, 16 Jan. 1949 (C, F); intertidal, north shore of St. Vincent sound, 10 miles west of Apalachicola, Drouet & Nielsen 10985, 16 Jan. 1949 (C, F); intertidal, shore of Apalachicola bay, south-east Apalachicola, Drouet & Nielsen, 10993, 16 Jan. 1949 (C, F). Gulf county: intertidal, on shore, rocks and palmetto stumps, St. Joseph bay, at mouth of a tidal stream, north of Port St. Joe, Drouet & Nielsen 10933, 10937, 10938, 15 Jan. 1949 (C, F); inter-

tidal, in tidal stream, north of Constitution park, Port St. Joe, *Drouet & Nielsen 11643*, 31 Jan. 1949 (C, F). Hernando county: on *Juncus*, Battery Point, Gulf of Mexico, *Brannon 563*, 33 Oct. 1948, (C, U). Lee county: salt flat, region of Hendry creek, about 10 miles south of Fort Myers, *Paul C. Standley 73250*, 11-25 Mar. 1940 (C). Levy county: intertidal, on wood, Way key, *Drouet & Nielsen 11110*, on docks, Way key, *Drouet & Nielsen 11132, 11147*, shore of cove, Way key, *Drouet & Nielsen 11150, 11154, 11199*, 22 Jan. 1949 (C, F). Monroe county: Cudjoe key, *Lawrence B. Isham 22*, 1 Oct. 1952 (C). Palm Beach county: on rocks between tide-marks, west shore of Lake Worth at Flagler memorial bridge, West Palm Beach, *Drouet & Louderback 10196*, 23 Dec. 1948 (C). Taylor county: on rope, brackish water of Daughter creek, Steinhatchee, *Drouet & Nielsen 11222*, 23 Jan. 1949 (C, F); intertidal, confluence of Daughter creek and Steinhatchee river, Steinhatchee, *Drouet & Nielsen, 11223*, 23 Jan. 1949 (C, F); on pilings, intertidal, shore of Steinhatchee river, Steinhatchee, *Drouet & Nielsen 11241a*, 23 Jan. 1949 (C, F). Wakulla county: intertidal, St. Marks river, Port Leon, *Drouet & E. M. Atwood 11453, 11455, 11456, 11466a*, 26 Jan. 1949 (C, F); shore of East river, at Gulf of Mexico, *Drouet, Madsen & Crowson 11741*, 1 Feb. 1949 (C, F); salt flats, north of lighthouse, St. Marks wildlife refuge, *Nielsen 7, 8, 9*, 4 Oct. 1951 (C, F).

As many as 12 trichomes were frequently observed within a common sheath. Cells were generally about 5μ in length with apical cells about 8.5μ . Trichome diameter was $1.5-2 \mu$. The hormogonial stages of this species may easily be confused with *Oscillatoria amphibia* Gom. The alga is commonly found with *Bostrychia* sp., *Calothrix scopulorum* B. & F., *Entophysalis crustacea* (J. Ag.) Dr. & Daily, *Lyngbya aestuarii* Gom., *L. lutea* Gom., *L. semiplena* Gom., *Microcoleus chthonoplastes* Gom., *Oscillatoria Corallinae* Gom., *O. margaritifera* Gom., *Plectonema calotrichoides* Gom. and *Symploca atlantica* Gom. It has been reported for the state by Madsen & Nielsen (1950) and Brannon (1952).

4. *Microcoleus acutissimus* Gardner. Mem. N. Y. Bot. Gard. 7: p. 55, pl. 11, f. 2 (1927).

Filaments small and relatively straight, 400-500 μ long, 20-35 μ diameter, containing 15-30 trichomes, closed at the conical tips when young, later opened and the trichomes extruding; trichomes straight, almost parallel

in the sheath, not constricted at the cross-walls, long and very sharply acuminate at the apices; 1.8-2.2 μ diameter; cells pale aeruginous, homogeneous, 2-4 times as long as diameter; apical cell longer and very sharp, conical; cross-walls obscure; sheath hyaline, irregular along the margin, somewhat mucous, not turning blue with chlor-zinc-iodine reagent.

Florida: *Smith*, Mar. 1878 (P). Alachua county; soil, Primrose St., Hibiscus Park, Gainesville, *Brannon*, 187, 188, 23 July 1943 (C, U); Gainesville, *Brannon* 307, 20 Aug. 1945 (C, U). Broward county: soil, forest south of South lake, Hollywood, *Drouet* 10315, 29 Dec. 1948 (C, F). Franklin county; sand dunes shore of Apalachicola bay at east end of John Gorrie causeway, west of Eastpoint, *Drouet* & *Nielsen*, 10960, 16 Jan. 1949 (C, F). Lee county: on tidal flats, region of Hendry creek, about 10 miles south of Fort Myers, *Paul C. Standley* 73180, 73466, 11-25 Mar. 1940 (C). Marion county: Dunnellon, *Brannon* 377, 20 Oct. 1946 (C). Monroe county: thallus green, on black mud, button-wood marsh in pine-palm woods north-west of Inn, Big Pine key, *E. P. Killip* 41942, 18 Feb. 1952 (C). Pinellas county: water-fall, Belleair, *Nielsen*, *Madsen* & *Crowson* 467, 19 Sept. 1948 (C, F). Wakulla county: Phillips picnic grounds, Newport, *Nielsen*, *Madsen* & *Crowson* 197, July 1948 (C, F); Spillway dam, Phillips pool, St. Marks wildlife refuge, *Nielsen*, *Madsen* & *Crowson* 479, 9 Oct. 1948 (C, F); on bases of trees in St. Marks river, Newport, *Drouet*, *Madsen* & *Crowson* 10815, 13 Jan. 1949 (C, F); among moss, bank of limestone ditch, Newport, *H. R. Wilson*, 23 July 1952 (C, F).

Average cell length was 7 μ . The species was commonly found with *Coccochloris stagnina* Spreng., *Anacystis dimidiata* (Kütz.) Dr. & Daily, *Microcoleus paludosus* Gom., *M. vaginatus* Gom., *Schizothrix Lamyi* Gom., *S. purpurascens* Gom., *Scytonema crustaceum* B. & F. and *S. ocellatum* B. & F. It has been reported for the state by *Drouet* (1939), *Nielsen* & *Madsen* (1948a), *Crowson* (1950) and *Brannon* (1952).

5. *Microcoleus paludosus* Gomont. Monogr. Oscill. p. 358, pl. 14, f. 13 (1892).

Filaments growing among other algae, or intricate in a black to blue-green stratum, tortuous, simple or cleft apices. Sheaths somewhat mucous, apices diffluent and open or acuminate and closed, not turning blue with chlor-zinc-iodine. Trichomes brilliant blue-green, parallel, straight, or funiform-contorted, not constricted at cross-walls, 5-7 μ wide; cells about as

long as diameter to double the width, 4-13 μ long; cross-walls never granular; apical cell never capitate.

Microcoleus paludosus var *acuminatus* Gardner. Member N. Y. Bot. Gard. 7: p. 57, pl. 11, f. 5 (1927).

Trichomes few in sheath, 5-6 μ diameter, pale aeruginous, 3-5 cells at the apices tapering to a very sharp point, and in part slightly uncinatae.

Alachua county: in culvert, Bivens Arm to Paynes prairie, south of Gainesville, *Brannon* 97, 14 Aug. 1942 (C, U); Hibiscus park, Gainesville, *Brannon* 179, 14 July 1943 (C, U); *Brannon* 243, 4 Apr. 1944 (C, F, U); 221, 30 Apr. 1944 (C, F, U); 271, 18 Aug. 1944 (C, U); 361, 19 July 1946 (C, U); 377, 18 Aug. 1948 (C, U). Dixie county: near Shamrock, *Paul C. Standley* 92730, 6 Mar. 1946 (C). Franklin county: sand dunes, shore of Apalachicola bay at east end of John Gorrie causeway, west of Eastpoint, *Drouet & Nielsen* 10958, 10962, 16 Jan. 1949 (C, F). Gadsden county: Little river, U. S. highway no. 90, 8 miles east of Quincy, *Nielsen* 1432, 9 July 1949 (C, F); Apalachicola river flood plain, U. S. highway no. 90, Chattahoochee, *Nielsen* 1439, 1441, 1442, 9 July 1949 (C, F). Jackson county: on bank, under Chipola river bridge, 1 mile north of Marianna, *C. E. Ruff*, 28 July 1952 (C, F). Leon county: St. Marks river, Little Natural Bridge, *Nielsen, Madsen & Crowson* 145, June 1948 (C, F). Judge Andru's magnolia forest, Lake Iamonia, *Nielsen & Madsen* 378, 379, 412, Aug. 1948 (C, F); U. S. highway no. 90, Ochlockonee river, *Nielsen & Madsen* 275, 31 Aug. 1948 (C, F); dried pool, open woods west of F.S.U., Tallahassee, *Drouet & Crowson* 10444, 5 Jan. 1949 (C, F); on roadside bank, west of F.S.U., Tallahassee, *Drouet & Crowson* 10449, 5 Jan. 1949 (C, F); barren ground, greenhouse F.S.U., *Drouet & Crowson* 10458, 10465, 10466, 5 Jan. 1949 (C, F); barren grounds, woods along Ochlockonee river at U. S. highway no. 90, west of Stephenville, *Drouet, Crowson & Petersen* 10493, 10504, 6 Jan. 1949 (C, F); along state highway no. 20, 19 miles west of Tallahassee, *Nielsen & Madsen* 799, 22 Jan. 1949 (C, F); F.S.U. campus, *Nielsen*, 14 July 1952 (C, F). Liberty county: Apalachicola river flood plain, Bristol, *Nielsen & Madsen* 437, Aug. 1948 (C, F); Ochlockonee river swamp at state highway no. 20, *Nielsen & Kurz* 876, 877, 19 Feb. 1949 (C, F); Rock Bluff, *J. E. Harmon* 4, 4 Nov. 1950 (C, F). Monroe county: on black mud, saline flats along road through Matthews property, Big Pine

key, *E. P. Killip* 41900, 7 Feb. 1952 (C). Santa Rosa county: sand dunes, east of Pensacola beach, *Drouet, Nielsen, Madsen, Crowson & Pates* 10575, 8 Jan. 1949 (C, F). Wakulla county: Phillips picnic grounds, Newport, *Nielsen, Madsen & Crowson* 176, July 1948 (C, F); Log sulfur spring, Newport, *Nielsen, Madsen & Crowson* 244, Aug. 1948 (C, F); wet bank, St. Marks river, Newport, *Drouet, Madsen & Crowson* 10822, 13 Jan. 1949 (C, F); dried pool in road near St. Marks river, Newport, *Drouet, Madsen & Crowson* 10792, 13 Jan. 1949 (C, F).

The species has been found with *Anacystis montana* (Lightf.) Dr. & Daily, *Cylindrospermum licheniforme* B. & F., *Microcoleus rupicola* (Tild.) Drouet, *M. vaginatus* Gom., *Nostoc Muscorum* B. & F., *N. ellipsoidum* B. & F., *Porphyrosiphon Notarisii* Gom., *Schizothrix purpurascens* Gom. and *Symploca Muscorum* Gom. It has been reported for the state by Nielsen & Madsen (1948a) and Brannon (1952).

6. *Microcoleus lacustris* Gomont. Monogr. Oscill. p. 359 (1892).

Filaments matted into a black to blue-green stratum, tortuous, simple or branched here and there with cleft apices. Sheaths somewhat thin, mucous and agglutinated, occasionally diffluent, apices often diffluent, never turning blue with chlor-zinc-iodine. Trichomes brilliant blue-green, parallel, outside sheath straight, very constricted at cross-walls, 4-5 μ wide; cells generally subglobular to three times trichome diameter, 6-12 μ long, sparsely scattered globular protoplasmic granules; cross-walls never granular; apical cell! more or less obtuse conical, never capitate.

Alachua county: Primrose St., Hibiscus park, Gainesville, *Brannon* 172, 179, May 1942 (C, F). Gadsden county: Little river at U. S. highway no. 90, 8 miles east of Quincy, *Nielsen* 1427, 9 July 1949 (C, F); edge of river, Rock Bluff, *J. E. Harmon* 29, 4 Nov. 1950 (C, F). Monroe county: marshy places, stunted button-wood stand, west of artificial lake, Big Pine key, *E. P. Killip* 41911, 9 Feb. 1952 (C). Wakulla county: shallow stream, 5.5 miles south-east of Newport, St. Marks wildlife refuge, *Nielsen, Madsen & Crowson* 44, 2 May 1948 (C, F); Phillips picnic grounds, Newport, *Nielsen, Madsen & Crowson* 192, July 1948 (C, F); sulfur springs, one-half mile north of Newport, *Drouet, Crowson & Thornton* 11341a, 25 Jan. 1949 (C, F).

The species is found with *Lyngbya* sp., *Microcoleus rupicola* (Tild.) Dr., *Pithophora oedogonia* (Mont.) Wittr. and *Spirogyra* sp.

It has been reported for the state by Brannon (1945, 1952) and Nielsen & Madsen (1948a).

7. *Microcoleus rupicola* (Tild.) Drouet. Field Mus. Nat. His. Bot. Series 20 (7): 167. (1943).

Stratum ragged, fragile, blue-green to discolored, long delicate filaments, bases of heavy cylinders including up to 50 trichomes, above abundantly branched, solitary branches often with many trichomes included; sheath hyaline wide, either not or obscurely lamellose, eroded or corrugate at margins, turning blue with chlor-zinc-iodine; trichomes blue-green, 3-4 μ wide, not or scarcely constricted at cross-walls, attenuate apices, cell length 1½-more times the diameter, protoplasm blue-green, sometimes granular, cross-walls not granular, apical cell long and conical, apex obtuse.

Alachua county: in culvert, Bivens Arm to Paynes prairie, south of Gainesville, *Brannon* 97, 14 Aug. 1942 (C, U); soil, Hibiscus park, Gainesville, *Brannon* 219, 235, 20 June 1944 (C, F); 274, 21 Aug. 1944 (C, U); 373, 14 Oct. (C, U). Gadsden county: soil, U. S. highway no. 90, 4 miles east of Quincy, *Drouet, Nielsen, Madsen & Crowson* 10412, 4 Jan. 1949 (C, F); at Little river, U. S. highway no. 90, 8 miles east of Quincy, *Nielsen* 1414, 1415, 9 July 1949 (C, F); edge of river, Rock Bluff, *J. E. Harmon* 29, 4 Nov. 1950 (C, F). Jackson county: red clay banks, U. S. highway no. 90, 5 miles east of Marianna, *Drouet, Nielsen, Madsen & Crowson* 10332, 10336, 4 Jan. 1949 (C, F); on path of headquarters bldg. Florida Caverns State Park, *Drouet, Nielsen & Madsen* 10371, 10373, 4 Jan. 1949 (C, F). Leon county: St. Marks river at Little Natural bridge, *Nielsen, Madsen & Crowson* 147, June 1948 (C, F); Lake Iamonia dam, *Nielsen & Madsen* 411, 412, August 1948 (C, F); Natural Well, 1 mile north-east of Woodville, *Nielsen, Madsen & Crowson* 587, 30 Oct. 1948 (C, F). Liberty county: Apalachicola river flood plain, Bristol, *Nielsen & Madsen* 437, August 1948 (C, F); sandy clay bank, Apalachicola river at Rock Bluff, *M. H. Voth* 26, 3 Nov. 1950 (C, F); edge of Apalachicola river, Rock Bluff, *J. E. Harmon* 4, 4 Nov. 1950 (C, F). Palm Beach county: sand in park at Flagler drive and 3rd St., West Palm Beach, *Drouet & Louderback* 10225, 24 December 1948 (C, F). Wakulla county: Spillway dam at Phillips lake, St. Marks wildlife refuge, *Drouet & Crowson* 821, 14 Jan. 1949 (C, F).

In the specimens examined, trichome diameter averaged 3 μ , cell length varied from 4 to 7 μ with apical cell length about 5 μ . There

were conspicuous constrictions at the cross-walls. Usually 10-20 trichomes were enclosed in a common sheath. Drouet states that where filaments have become parasitized by fungi, the sheaths are lamellose and corrugate, and simulate those of *Schizothrix lacustris* Gom. The following algae were commonly found associated: *Fischerella ambigua* (B. & F.) Gom., *Microcoleus lacustris* Gom., *M. paludosus* Gom., *M. vaginatus* Gom., *Nostoc ellipsorum* B. & F., *Plecotonema Nostocorum* Gom., *Schizothrix purpurascens* Gom. and *Symploca muscorum* Gom. The species has been reported for the state by Nielsen & Madsen (1948a), Crowson (1950), and Brannon (1952).

Microcoleus corymbosus Harv. reported from Key West by W. H. Harvey (1875) and by W. G. Farlow (1875, 1876) has been re-determined as *Gardnerula corymbosa* (Harvey) J. De-Toni. *Microcoleus subtorulosus* Gomont has been reported for the state by Wolle (1887) and by Smith & Ellis (1943). Drouet (1939) has re-determined the J. D. Smith specimen as reported by Wolle as *Lynghya putealis* Mont. ex. Gom. No specimen has been preserved of the Smith and Ellis collection. The inclusion of the species in Tilden (1910) on the basis of the one Florida specimen above, makes it very probable that their alga was one of the more common soil forms.

LITERATURE CITED

BRANNON, MELVIN A.

1945. Factors affecting the growth of Myxophyceae in Florida. *Quart. Journ. Fla. Acad. Sci.* 8 (4): 296-303.
1952. Some Myxophyceae in Florida. *Quart. Journ. Fla. Acad. Sci.* 15 (2): 70-78.

CROWSON, DOROTHY E.

1950. The Algae of a Modified Brackish Pool. *Fla. State Univ. Studies* 1: 1-32.

DROUET, FRANCIS

1937. Some Myxophyceae from the Canal Zone. *Bull. Torrey Bot. Club* 64: 599-604.
1939. Francis Wolle's Filamentous Myxophyceae. *Field Mus. Nat. Hist. Bot. Series* 20 (2): 17-64.
1943. Myxophyceae of Eastern California and Western Nevada. *Field Mus. Nat. Hist. Bot. Series* 20 (7): 145-176.

FARLOW, W. G.

1875. List of the Marine Algae of the United States. *Proc. Amer. Acad. Arts & Sci.* 11: 351-380.

1876. List of the Marine Algae of the United States. *Report of the U. S. Fish Commission.* pp. 1-28.

GOMONT, M.

1892. Monographie des Oscillariees. *Ann. Sci. Nat. Bot.* VII. 15: 263-368; 16: 91-264.

HARVEY, WILLIAM H.

1857. Nereis Boreali-Americana. *Smithsonian Contribution XIX*: 1-40.

HUMM, HAROLD J.

1952. Notes on the Marine Algae of Florida. I. The Intertidal Rocks at Marineland. *Fla. State Univ. Studies* 7: 17-23.

MADSEN, GRACE C., and C. S. NIELSEN

1950. Check List of the Algae of Northern Florida II. *Quart. Journ. Fla. Acad. Sci.* 13: 1-19.

NIELSEN, C. S.

1954. The Non-sheathed Oscillatoriaceae of Northern Florida. *Hydrobiologia* (in press).

NIELSEN, C. S., and GRACE C. MADSEN

1948a. Preliminary Check List of the Algae of the Tallahassee Area. *Quart. Journ. Fla. Acad. Sci.* 11 (4): 111-117.

1948b. Check List of the Algae of Northern Florida I. *Quart. Journ. Fla. Acad. Sci.* 11 (2-3): 63-66.

SMITH, F. B., and H. R. ELLIS

1943. Preliminary Report on the Algal Flora of some Florida Soils. *Proc. Fla. Acad. Sci.* 6 (1): 59-65.

TAYLOR, WILLIAM RANDOLPH

1928. Marine algae of Florida with special reference to the Dry Tortugas. *Papers from the Tortugas Laboratory (Carnegie Institution of Wash.)* 25: 1-219.

TILDEN, JOSEPHINE

1910. *Minnesota Algae*, Vol I, Bot. Series VIII, Minneapolis, Minn.

WOLLE, FRANCIS

1877. Fresh Water Algae III. *Bull. Torrey Bot. Club* 6 (35): 181-189.

1887. *Fresh Water Algae of the United States.* Bethlehem, Pa.

BORON IN FLORIDA WATERS

HOWARD T. ODUM and BRUCE PARRISH
Dept. of Biology, University of Florida

As part of a study of the factors controlling productivity of Florida's constant temperature springs, a few boron analyses were made of waters from springs, lakes and streams to determine if existing boron concentrations were limiting plant growth in Florida's aquatic communities.

Boron is one of the biologically active minor elements. Boron is present in plant tissues in high concentration relative to the plants substrate (Hutchinson 1943). Like many biologically active elements it is necessary in small concentrations and becomes toxic in larger concentration. (Zittle, 1951.)

Water samples collected in plastic vessels were analyzed for boron with a tumeric colorimetric method modified from Naftel (1939) and Winsor (1948). We are especially grateful to Mr. H. W. Winsor of the Florida Agricultural Experiment Station for showing us his analytical methods and criticizing our results. This method which had been used with heterogeneous soil extracts seemed suitable for natural waters. Repeated analyses of the same sample of water from Silver Springs showed a standard deviation of .00311. Thus the percent error expected in 95% of the analyses is less than 25%.

The data on boron in Florida waters are given in Table I. These data are arranged in order of the chlorinities of the waters. Similar concentrations were found for Hawaiian waters by Tanada and Dean (1942).

As shown in the graph in Figure 1 there is a correlation between the boron and chloride concentrations. This is not a chloride bias effect on the chemical analysis because the three analyses of sea water did not differ radically from the 4.7 ppm usually found by other methods in the open ocean water of chlorinity 19,000 (Sverdrup, Johnson, Fleming, 1946).

Boron can be expected to be associated with chlorides because of some similarities in the geochemical behavior of the two elements. Both tend to be washed out of rock strata rapidly and to become concentrated in the ocean or in the desert lakes of arid regions. Where residual salt water is trapped in pore spaces of

sediments and is entering springs and streams in the ground water, both boron and chloride may be expected to be added together. The observed correlation of boron and chloride in Florida waters is probably due to these geochemical similarities. As shown in Table I the ratio of boron to chloride in those waters which receive ground water salt is of the same order of magnitude as that in sea water. Data are given by Odum (1953) showing that the chloride content of fresh water in peripheral Florida below 25 ft. elevation can be accounted for by residual pore space salt from the ground water.

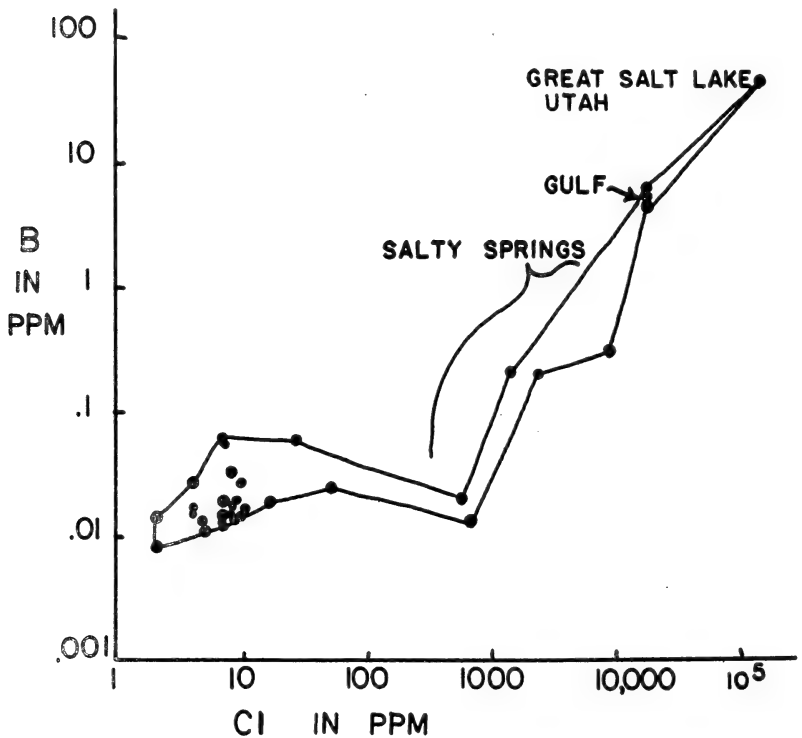

In several springs, especially two Sarasota County springs, Warm Salt Springs, Little Salt Springs, the B/Cl ratio is considerably lower than that in the sea. One possible explanation is that these drain evaporite deposits. Dr. A. P. Black, Dept. of Chemistry, Univ. of Florida, suggested that the high temperature of Warm

TABLE I

Boron in Florida Waters. Chlorinities Determined with the Mohr Method or from Ferguson, et. al., 1947 and B/Cl Ratios Are Given. Great Salt Lake, Utah, is Included for Comparison.

Locality and Date	Boron ppm	Chloride ppm	B/Cl $\times 10^{-4}$
Great Salt Lake, Utah, 1950 (water furnished by Dr. W. Hartmann, Univ. of California)	43.5	149,224	2.9
Sea Water			
Mouth of Tampa Bay, May 30, 1953	4.4	18,700	2.3
Gulf, June, 1953	6.3	19,000	3.3
Gulf, June, 1953	5.4	19,000	2.8
Florida Springs, 1953			
Warm Salt Springs, Sarasota Co., June 17	.30	9,350	.3
Salt Springs, Marion Co., June 14	.20	2,439	.8
Little Salt Springs, Sarasota Co., June 17	.20	1,430	1.4
Blue Springs, Volusia Co., June 19	.125	775	1.6
Ponce DeLeon Springs, Volusia Co., June 19	.055	622	.9
Homosassa Springs, Citrus Co., June 6	.186	570	3.3
Chassahowitzka Springs, Citrus Co., June 20	.024	53	4.5
Silver Springs, Marion Co., May 28			
Boil, mean of 5 replications	.0154	8	19.
$\frac{3}{4}$ mile downstream, mean of 5 replications	.0170	8	21.
$\frac{3}{4}$ mile downstream, mean of 4 samples	.015	8	19.
Sanlando Springs, Seminole Co., June 19	.032	8	40.
Magnesia Springs, Alachua Co., June 10	.015	8	19.
Orange Springs, Marion Co., June 1	.019	7	27.
Weekiwachee Springs, Hernando Co., June 6	.013	5	26.
Ichtucknee Springs, June 9, at Rt. 27 bridge	.017	4	42.
Streams, 1953			
Orange Creek, Marion Co., June 1	.019	9	21.
Fenholloway River, Foley, June 9	.027	4	68.
Suwannee River, Branford, June 9	.012	7	17.
Santa Fe River, High Springs, June 9	.027	10	27.
Hogtown Creek, Gainesville, Rt. 26, May 31	.012	7	17.
Hatchet Creek, Gainesville, Rt. 24, May 31	.015	7	21.
Lakes, 1953			
Morris Lake, Putnam Co., June 1	.011	5	22.
North Twin Lake, Putnam Co., June 1	.013	7	53.
Lady Slipper Lake, Putnam Co., June 1	.016	4	41.
Lochloosa Lake, Alachua Co., June 3	.017	11	15.
Newnans Lake, Alachua Co., May 31	.012	7	17.
Rainwater, thunderstorm, Gainesville, June 14			
Sample No. 1	.009	2	43.
Sample No. 2	.015	---	---

Salt Springs in contrast to most of Florida's springs might be due to the heat of solution. Alternatively some boron in residual salt water may have been removed from the water by the sediments.

In the upland waters which do not receive so much salty ground water the boron content is low. However, the B/Cl ratio is 10 times or more larger than sea water and this raises a problem. Some of the boron like much of the chloride may come from cyclic salt. If representative, the two rainwater analyses suggest that the atmospheric derived boron might be adequate to account for the boron in upland lakes. However, this explanation of the boron content in lake waters requires a differential action in the cyclical salt transfer to account for the high B/Cl. Small amounts of the boron mineral tourmaline are found in some of Florida's sands so that the high B/Cl ratio may alternatively be accounted for by boron received from soils.

In many natural waters inorganic phosphorus is limiting to plant growth. A comparison of phosphorus with boron shows which is more likely to be used up first and thus limiting to growth. The B/P ratio in Silver Springs water is maintained at .35, but the B/P ratio in the aquatic plants (algae coated *Sagittaria*) is .0018. Thus if boron and phosphorus are removed from the water in the ratio found in the plants phosphorus will be used up long before boron.

A trace element may affect the growth rate even when its concentration is not so small as to be limiting. Baumeister (1943) found that .5—100 ppm B had a growth promoting effect on aquatic spermatophytes. Whether the higher boron concentrations in the more salty springs and streams contribute to fertility there is not known definitely.

LITERATURE CITED

BAUMEISTER, W.

1943. Influence of Boron on Photosynthesis and Respiration of Submerged Plants. *Jb. wiss. Bot.*, 91: 242-277. Only an abstract seen (*C.A.* 39, 1899).

FERGUSON, G. E., LINGHAM, C. W., LOVE, S. K., and VERNON, R. O.
1947. Springs of Florida. *Fla. Geol. Surv. Bull.* 31.

HUTCHINSON, G. E.

1944. The Biogeochemistry of Aluminum and of Certain Related Elements. *Quart. Rev. Biol.*, 18: 1-29, 129-253, 331-363.

NAFTEL, J. A.

1939. Colorimetric Microdetermination of Boron. *Indus. & Engin. Chem., Analyt., Ed.*, 11: 407-409.

ODUM, H. T.

1953. Factors Controlling Marine Invasion in Florida Waters. *Bull. Mar. Sci. Gulf and Caribbean*. In press.

SVERDRUP, H. U., JOHNSON, M. W., and FLEMING, R. H.

1946. *The Oceans*. Prentiss-Hall, N. Y.

TANADA, T., and DEAN, L. A.

1942. Boron in Some Hawaiian Soils and Crops. *Hawaii Plant. Rec.* 46: 65-74. Only an abstract seen.

WINSOR, H. W.

1948. Boron Microdetermination in Fresh Plant Tissue. *Analyt. Chem.*, 20: 176-181.

ZITTLE, C. A.

1951. Reaction of Borate with Substances of Biological Interest. *Advanc. Enzymol.* 12:

Quart. Journ. Fla. Acad. Sci. 17(2), 1954.

A NEW CRAYFISH FROM THE UPPER COASTAL PLAIN
OF GEORGIA (DECAPODA, ASTACIDAE)

HORTON H. HOBBS, JR.

Samuel Miller Biological Laboratories, University of Virginia

The Advena Section of the genus *Procambarus* was erected by Hobbs (1942) to indicate the close affinities of six species and subspecies [*advena* (LeConte, 1856: 402); *geodytes* Hobbs (1942: 80); *pygmaeus* Hobbs (1942: 83); *r. rogersi* (Hobbs, 1938: 61); *r. ochlocknensis* Hobbs (1942: 89); and *r. campestris* Hobbs (1942: 90)] which inhabit certain areas of the Coastal Plain in Georgia and Florida. Because the former three species are so obviously more closely allied to one another than any one of them is to the three subspecies of *P. rogersi* Hobbs proposed that the Section consist of two groups which he designated the Advena and Rogersi Groups. The species herein described, while resembling the members of the Advena Group more closely than those of the Rogersi Group, is so distinct that it seems advisable to erect a monotypic group for its reception. Further, the first pleopod of the male is so modified that the definition of the Section must be revised in order that this disjunct species may be included within it.

ADVENA SECTION (HOBBS, 1942: 73)

Diagnosis.—The cephalodistal surface of the first pleopod of the first form male never terminates in a ridge or knob-like prominence but in a corneous, often-reduced cephalic process; if the cephalic process is absent, then the cephalodistal surface is almost flush with the centrocephalic process of the central projection, *or the terminal elements are directed distinctly caudad*. The mesial process is spiniform or blade-like, and directed distad *or caudad*; the central projection is decidedly the most conspicuous terminal element, and is either laterally compressed or directed across the cephalodistal tip of the appendage. The caudal element is present as a large bump or thumb- or lip-like knob. The rostrum is broad and short and without lateral spines; the areola is narrow or obliterated; the male has hooks on the ischiopodites of the third, or on the third and fourth pereopods; the chelae are depressed and bear a cristiform row of tubercles along the inner margin of the palm.

TRUCULENTUS GROUP

Diagnosis.—The terminal elements of first pleopod of first form male arise from the caudal side of the distal portion of the appendage and are directed caudad; the mesial process is completely obscured in lateral aspect by the central projection. The distal portion of appendage is greatly elongated in the longitudinal plane of the body (not the appendage). Hooks are present on the ischiopodites of the third pereopods of the male.

PROCAMBARUS TRUCULENTUS,¹ sp. nov.

Diagnosis.—Rostrum without lateral spines; areola very narrow with room for only two punctations in narrowest part; male with hooks on ischiopodites of third pair of pereopods only; palm of chela with a cristiform row of tubercles; suborbital angle lacking; postorbital ridges terminating cephalad without spines or tubercles; no lateral spines present on carapace. First pleopod of first form male terminating in three caudally directed parts: mesial process and central projection acute; caudal knob, present immediately proximad of central projection, truncate and somewhat flattened (Figs. 1 and 5). Annulus ventralis ovate with its greatest length in the longitudinal axis of the body; sinus originates in bottom of submedian pit, runs gently caudosinistrad, then caudodextrad, again caudosinistrad to the midventral line where it turns caudad, and terminates before cutting the caudal margin of the annulus.

Holotypic Male, Form I.—Body subovate, compressed laterally. Abdomen narrower than thorax (11.5-15.9 mm. in widest parts respectively). Width of carapace slightly greater than depth in region of caudodorsal margin of cervical groove. Areola very narrow with room for only two punctations in narrowest part (punctations widely spaced in two irregular rows); cephalic section of carapace 1.6 times longer than areola (length of areola about 39% of entire length of carapace).

Rostrum excavate above, almost reaching distal end of penultimate segment of antennule; margins converging, raised but not thickened; acumen indistinct; upper surface of rostrum smooth except for a single row of setiferous punctations at base of marginal ridges and two or three scattered ones. Subrostral ridges well defined but

¹ *L. trux*—savage, rough, ferocious; *L. lentus*—tenacious.

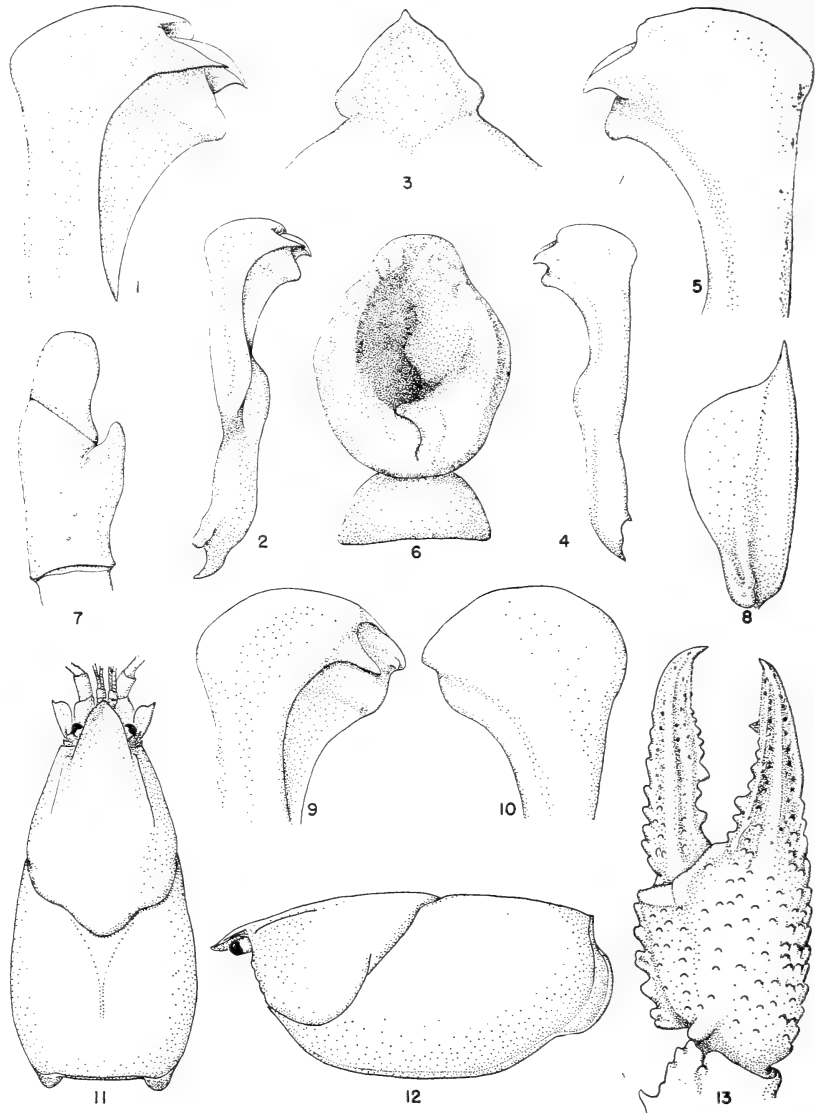

EXPLANATION OF PLATE

Procambarus truculentus

- Figs. 1 and 2—Mesial view of first pleopod of holotype.
 Fig. 3—Epistome of holotype.
 Figs. 4 and 5—Lateral view of first pleopod of holotype.
 Fig. 6—Annulus ventralis of allotype.
 Fig. 7—Basipodite and ichiopodite of third pereiopod of holotype.
 Fig. 8—Antennal scale of holotype.
 Fig. 9—Mesial view of first pleopod of morphotype.
 Fig. 10—Lateral view of first pleopod of morphotype.
 Fig. 11—Dorsal view of carapace of holotype.
 Fig. 12—Lateral view of carapace of holotype.
 Fig. 13.—Upper surface of distal podomeres of cheliped of holotype.

scarcely evident in dorsal aspect. Postorbital ridges moderately strong, grooved, and terminating cephalad without spines or tubercles. Suborbital angle lacking, branchiostegal spine moderately strong. No spines present on sides of carapace. Surface of carapace punctate and polished dorsad, granulate laterad.

Abdomen shorter than carapace (27.3 - 31.7 mm.).

Cephalic section of telson with two spines in the dextral and three in the sinistral caudolateral corners.

Epistome (Fig. 3) subtriangular with a cephalomedian spine. Antennules of the usual form; however, no spine present on ventral surfaces of basal segments. Antennae extend caudad to second abdominal segment; antennal scale (Fig. 8) small with a strong spine on outer distal margin; lamellar portion gently rounded and broadest distad of middle.

Right chela (Fig. 13) moderately strong, depressed, and studded with tubercles. Inner margin of palm with a cristiform row of seven tubercles (left chela with eight). Fingers only slightly gaping. Opposable margin of dactyl with nine corneous tubercles on proximal four-fifths; between and distad of these is a single row of minute denticles. Mesial margin of dactyl with a row of strong ciliated tubercles which are progressively more squamous distad. Upper surface of dactyl with a well-defined submedian ridge which is flanked proximally by tubercles and distally by setiferous punctations. Lower surface of dactyl tuberculate proximad and bearing setiferous punctations distad. Opposable margin of immovable finger with a row of six large tubercles on proximal three-fifths, and a much larger one at base of distal fourth. Outer margin of immovable finger with a distinct ridge which bears a row of ciliated tubercles proximad, the latter giving way to a row of setiferous punctations distad. Proximal, inner, lower surface with a row of five prominent tubercles; outer proximal portion with scattered tubercles, and distal portion with setiferous punctations. Median ridge on upper surface of immovable finger flanked proximally by tubercles and distally by setiferous punctations. Near tip on outer margin of immovable finger is a large punctation bearing a heavy growth of setae; a similar punctation near tip of dactyl.

Carpus of first right pereopod about 1.6 times longer than broad; a well-defined longitudinal groove above; punctate except on inner surface which bears several spike-like tubercles (two distinctly

larger ones in middle, and two large ones somewhat below and distad of these two); in addition an irregular row of seven smaller ones along upper inner margin.

Merus punctate laterad and mesiad; upper surface with two very irregular rows of tubercles which are progressively larger distad; lower surface with a mesial row of eleven spike-like tubercles, and an outer row of eight; cephalad these two rows are joined by an oblique row of four similar tubercles.

Hooks on ischiopodites (Fig. 7) of third pereiopods only; hooks large with proximal surface excavate and setiferous. Bases of coxopodites of fourth and fifth pereiopods with ventrally projecting prominences; those on fourth large, heavy, and truncate; those on fifth smaller than those on fourth but more acute.

First pleopod (Figs. 1, 2, 4 and 5) reaching base of second pereiopod when abdomen is flexed. Tip terminating in three parts. Mesial process triangular with an elongate, acute, corneous tip; central projection corneous, short, and subtriangular; caudal element consists of a swollen and slightly compressed caudal knob lying immediately proximad of central projection. All three terminal elements directed caudad at about right angles to the main shaft of the appendage.

Allotypic Female.—Differs from the holotype in the following respect: Sides of epistome emarginate; cephalic section of telson with two spines in the dextral and one in the sinistral caudolateral corners; inner margin of palm of chela with a cristiform row of ten tubercles; other slight differences exist in the size and number of tubercles present on the several structures described for the holotype. Annulus ventralis (Fig. 6) deeply imbedded in sternum, subovate, with the greatest length in the longitudinal axis; deeply excavate (for course of sinus see Diagnosis). (See *measurements*.)

Morphotypic Male, Form II.—Differs from the holotype in the size and number of tubercles present on the several structures described, and while the three terminal elements of the first pleopod are present all are reduced and none corneous; the usual reduction of the secondary sexual characters is evident. (See Figs. 9 and 10, and *Measurements*.)

Color Notes.—Ground color of carapace grayish-tan; cephalic portion lighter than thoracic region, the latter dark green with a buff suffusion changing to buff along ventral margins. Cervical

groove, margins of rostrum, and postorbital ridges bluish-green. Abdomen grayish-buff with nondescript markings in cream and dark gray; pleura pale mauve on buff with a light greenish-gray line along base; telson and uropods with lateral portions and tips like pleura, otherwise colorless with grayish-green splotches. Ground color of chelae and pereopods buff with greenish-blue and gray markings (particularly at joints and on upper surfaces); tubercles on chelae bluish-green as are the bases of joints of dactyls; row of tubercles on inner margin of palm greenish-blue at base but cream at tips; outer margins of chelae and lower surfaces light orange-buff with pink suffusions; tubercles on opposable margins of fingers cream. Lower portion of body and appendages whitish cream. Hair on ventral surface light gray.

Measurements—(In Millimeters)

	Holo-type	Allo-type	Morpho-type
Carapace—			
Height	15.3	13.5	11.7
Width	15.9	14.5	12.4
Length	31.7	29.8	24.7
Areola—			
Width6	.7	.5
Length	12.0	11.0	9.2
Rostrum—			
Width	4.7	4.5	4.2
Length	4.7	4.4	4.1
Chela—			
Length of inner margin of palm	7.8	7.0	5.5
Width of palm	10.0	9.0	7.1
Length of outer margin of hand	23.2	19.2	15.7
Length of dactyl	14.9	12.0	10.0

Type Locality.—Boggy, seepage area 11 miles north of Lyons in Emanuel County, Georgia, on U. S. Highway 1. This seepage area lies on a gently sloping hill at the foot of which is a small sluggish creek. The area in which the crayfishes were found is approximately 200 feet up the hill from the creek, and probably only in rainy seasons is there any appreciable surface run-off into the stream. Conspicuous elements of the flora are pines, *Nyssa* sp., *Hypericum fasciculatum*, *Sarracenia flava*, *S. minor*, and *Lycopodium* sp. Other plants in the area are *Sarracenia psittacina*, *Syngonathus flavidulus*, *Cyanococcus* sp., *Erigeron vernus*, *Rhynchospora*

oligantha, *Drosera* sp., *Pogonia ophioglossoides*, *Juncus* sp., *Setiscapella subulata*, *Panicum* sp., *Pilostaxis racemosa*, and *Helenium* sp.²

Disposition of Types.—The holotypic male (No. 95670), allotypic female (No. 95671), and morphotypic male (No. 95672) are deposited in the United States National Museum. Of the paratypes one male, Form II, and one female are in the Museum of Comparative Zoology; one male, Form II, and one female in the Tulane Collection, and one male, Form I, 3 males, Form II, and 21 females are in my personal collection at the University of Virginia.

Range.—Jenkins, Emanuel, and Bulloch counties, Georgia. Apparently this species is confined to an area between the Ogeechee and Altamaha rivers in the upper Coastal Plain.

Specimens Examined.—GEORGIA: *Emanuel County*—5.5 miles northeast of Swainsboro, St. Hy. 56 (5-445-1b, 1 ♂ II, 1 ♀; 6.8 miles south of Swainsboro, U. S. Hy. 1 (6-1534-1, 1 ♂ II, 1 ♀); 11 miles north of Lyons, U. S. Hy. 1 (Type locality) (8-2337-3, 1 ♂ II, 6 ♀ ♀), (6-940-1, 3 ♀ ♀), (5-2541-1, 3 ♀ ♀), (8-0041-1, 1 ♂ I). *Bulloch County*—14.2 miles south of Millen, U. S. Hy. 25 (4-1744-3b, 1 ♂ I, 2 ♂ ♂ II, 3 ♀ ♀). *Jenkins County*—9.2 miles south of Millen, U. S. Hy. 25 (3-2739-6, 1 ♂ II, 1 ♀).

Relationships.—*Procambarus truculentus* is probably most closely allied to *Procambarus advena* (LeConte), but may readily be separated from it by the position assumed by the mesial process and central projection of the first pleopod of the male. The females of the two species are almost indistinguishable. While there are certain superficial resemblances of the first pleopod of the male of *truculentus* to that of the typical *Cambarus* pleopod it will be noted that in the former the mesial process is not evident in lateral aspect, whereas, the mesial process of the first pleopod of all species belonging to the genus *Cambarus* is always clearly seen in lateral view. Too, the prominent caudal knob is never so conspicuously evident in the latter.

Variations.—Considerable variation occurs among the specimens available. Particularly are the numbers of spines and tubercles on the cheliped variable; e.g., the inner margin of the palm may bear from seven to ten tubercles. The basal segment of the antennule

² Dr. A. M. Laessle of the University of Florida kindly identified these plants for me.

may or may not have a spine on its lower surface. The annulus ventralis may or may not show the low lateral tubercles shown in the drawing of the allotype. The mesial process of the first pleopod of the first form male from Bulloch County is broader throughout its length—not tapering as in the holotype.

Remarks.—In the rather small known range of *Procambarus truculentus* it occurs in colonies where each member apparently constructs its own complex burrow. These burrows are not unlike those described for *P. advena* (See Hobbs 1942: 78).

Unlike some of the more astute burrowing species, *P. truculentus* may be attracted to the surface of the water in the burrow thus obviating the necessity for laborious digging. Most of my specimens were collected by opening the mouth of a burrow with a spade and vigorously roiling the water. After this was done other burrows were similarly opened. When a number of them had been so treated, upon quietly approaching the open burrows, the crayfish were often seen at the surface of the water, lying in a horizontal position with one of the branchiostegites exposed, and thus relatively easily caught with the hand.

In order to determine the extent of some of the burrows they were carefully dissected, and it was found that while there were a number of passages that wound both vertically and horizontally, with several openings to the surface, there was usually only one passage which dipped much below the normal water table. Such passages were seldom more than two or three feet deep, and they usually had no more than one side branch.

The soil in the localities from which most of the specimens were taken is a black, sandy muck, and supports a dense growth of wire grasses, pitcher plants, and other bog-inhabiting plants. The water table fluctuates from the surface to about two feet below it.

The type locality has been visited in March, May, June, and August and in no instance was a first form male found; however, one of the males taken in August was brought into the laboratory where it moulted to first form in November. [Another second form male collected in another locality in April moulted in the laboratory during the following October.] In May more than a dozen burrows were examined, and all of them contained females with young approximately 10 mm. in length (from tip of rostrum to tip of telson). At this time no males could be found.

Procambarus truculentus is aggressively ferocious. On several occasions individuals placed in trays of shallow water have been observed to hurl themselves above the water surface in attempting to reach an object moved across the tray at a height of one foot. A previous "teasing" period was not required to elicit this aggressive response. The actual height of the jump was not measured but the animals can jump above the water surface when it is as little as two inches above the bottom of the container.

LITERATURE CITED

HOBBS, HORTON H., JR.

1938. A new Crawfish from Florida. Journ. Wash. Acad. Sci., 28 (2): 61-65, 1 fig.

1942. The Crayfishes of Florida. Univ. of Florida Pub., Biol. Sci. Series, 3(2): 1-179, 3 text figs., 11 maps, 24 pls.

LECONTE, JOHN

1856. Description of New Species of *Astacus* from Georgia. Proc. Acad. Nat. Sci., Philad., 7: 400-402.

Quart. Journ. Fla. Acad. Sci. 17(2), 1954.

A SUGGESTED INORGANIC FERTILIZER FOR USE IN BRACKISH WATER

MALCOLM C. JOHNSON

Marineland Research Laboratory, Marineland, Florida

INTRODUCTION

In July, 1952, funds were made available through the Marineland Research Laboratory to explore the possibilities of developing a commercial brackish-water pond culture system. The economics of such a system dictate an intensive type culture. That is, the per acre yield of any given seafood item must be sufficiently large to show a profit in the face of high investments and production costs. In view of the meager unit-area production figures available for saltwater ponds, it seemed highly improbable that the natural carrying capacity of coastal waters was great enough to meet this demand. Production then, had to be increased either through the addition of feed stuffs or by increasing the basic fertility of the pond water.

Smith and Swingle (1938) have shown that the carrying capacity, in terms of pounds of fish, of fresh waters varies directly with the production of plankton organisms. They demonstrated further that the production of plankton algae could be greatly increased by the addition of the major plant nutrients, nitrogen, phosphorus and potassium. To be properly utilized these materials had to be applied in such relative quantities as to be available in solution in the proportion in which they were absorbed by plankton algae (Swingle, 1947). Satisfactory fertilizer formulas have been ascertained for fresh waters in various parts of this country, the proportion of N:P:K varying with the relative nutrient deficiency of an area.

More recently, workers in Scotland (Gross, et al, 1946; Ramont, 1947) and at Woods Hole Oceanographic Institution (Edmondson and Edmondson, 1947; Pratt, 1949) have correlated increased plankton crops with the addition of inorganic fertilizers to brackish-water areas. The workers at Woods Hole did not study fertilization as such. Pratt (1949) studied the nutrition of phytoplankton by the artificial increase of nutrient elements that seemed most likely to be limiting natural plankton populations, while the Edmond-

sons (1947) undertook to study the general problems of productivity in aquatic environments. On the other hand, pond culturists, notably Smith and Swingle (1938), Surber (1943), Swingle (1947) and Ball (1949) concerned themselves with fertilization as a means to increased fish production with little emphasis on the intermediate nutritive cycle.

At Marineland the initial pond culture experiment was set up to give information on the carrying capacity, in terms of pounds of fish, of unfertilized estuarine waters and the increase in production due to fertilization. It was therefore necessary to determine a mixture of inorganic fertilizer that contained the major limiting plant nutrients in a ratio that would give satisfactory results when applied to salt or brackish water. At that time facilities were not available at the Research Laboratory for preliminary greenhouse experiments, so a fertilizer was formulated theoretically and used throughout the experiment. The purpose of the particular study reported here was to obtain an estimate of the efficiency of the formula devised.

FORMULATING THE FERTILIZER MIXTURE

Potassium is present in excess in sea water and was not considered a limiting factor in plankton production.

Nitrate nitrogen and phosphate phosphorus are present in sea water in the constant ratio 16:1 by atoms, or approximately 7:1 by weight. These materials are absorbed and released by marine plankton algae in the same ratio (Sverdrup, Johnson and Fleming, 1942). It seemed reasonable to assume that a satisfactory fertilizer for salt water would be one that delivered these nutrients in solution in the 7:1 ratio.

Because the analysis of commercial inorganic fertilizer is expressed as per cent elemental nitrogen, phosphoric acid, and potash, it was necessary to convert the 7:1 nitrate:phosphate ratio to the $N:P_2O_5$ equivalent. This gave a ratio of 1.6:0.76, which was the relative proportion of N to P_2O_5 desired in solution. Then, since Pratt (1949) had shown that a loss of $\frac{2}{3}$ of the added phosphorus might be expected, the relative P_2O_5 proportion was tripled, resulting in a 1.6:2.3 ratio, or approximately a 6-9-0 (1.6:2.3x4) analysis fertilizer. A commercial 7-9-0 fertilizer which was available in the Marineland area was adopted instead.

Actually, except *in vitro* an exact fertilizer for aquatic use is purely theoretical. Any mixture that gives the desired results without large excesses of any one nutrient would be acceptable.

EXPERIMENTAL UNITS

Four $\frac{1}{8}$ -acre rectangular ponds were excavated in alluvial mud soil typical of the tidal marsh areas of the Southeast Atlantic States. The above water portion of the dikes was composed of an admixture of mud, sand, and oyster shells, and was sufficiently high to prevent topping by flood waters. A twelve-inch inlet pipe was installed through one dike in each pond. The pipes in three of the ponds were fitted with automatic storm-gate valves that allowed water from the Intracoastal Waterway to enter the ponds whenever the pond water level fell below that of flood tide. The valves prevented the efflux of water during ebb tides. On the other pond the pipe was fitted with a stand-pipe that permitted the inflow and outflow of tidal water whenever flood tide exceeded the height of the stand-pipe. Each pond had an average depth of 3.5 feet.

The mud in which the ponds were dug was extremely impervious to water. Loss of water due to seepage was not measured, but was relatively slight, since each pond lost only two to four inches in depth between one high tide and the next.

The ponds are hereafter referred to by numbers 1 through 4.

METHODS

Each pond was stocked with 2,000 fingerling mullet (*Mugil cephalus*) per acre on December 31, 1952. Ponds 1 and 3 were fertilized, ponds 2 and 4 unfertilized during 1953.

Applications of the 7-9-0 fertilizer were made at the rate of 200 pounds per acre per month, which is equal to fourteen pounds of elemental nitrogen and eighteen pounds of P_2O_5 . On the basis of the calculated pond volume, the potential increase in dissolved N was approximately 1.48 ppm and in P_2O_5 approximately 1.69 ppm at each application. Actually these materials do not go into solution immediately but gradually over a period of hours or days, and are utilized in whole or part by algae as they dissolve. This being true, it was considered useless to make immediate determinations for dissolved N and P_2O_5 , since the concentrations indicated

would be only that part of the total nutrients that had dissolved but had not yet been absorbed by plants or bound chemically with other materials. Instead it seemed reasonable that when using guaranteed analysis fertilizer in a body of confined water that the total increase at fertilization would be the theoretical increase. The degree of balance of the mixture was determined by estimating the amounts of dissolved phosphorus and nitrogen at intervals intermediate to the applications of fertilizer. A consistent excess of one nutrient would indicate that the other had become limiting to plankton production and should be increased in subsequent experiments.

TABLE I
Nutrient Analysis of Fertilized Ponds, 1953

Pond 1									
Date	Date of Last Fertilization	7-9-0/ Acre	P ₂ O ₅	NO ₃ ⁻	NH ₄ ⁻	Total Dissolved N	Salinity	pH	Temp.
		Lbs.	ppm	ppm	ppm	ppm	0/00		°F.
	1-12	200							
	1-26	200							
	2-10	200							
	3-7	200							
	4-9	200							
	4-22	100							
5-19	5-9	100	0.32	0.00	---	0.00	35.5	---	83
6-2	5-25	100	T	0.00	0.00	0.00	35.4	7.8	83
6-19	6-9	100	0.62	0.00	0.00	0.00	35.6	7.6	84
7-21	6-23	100	0.00	0.00	T	T	35.0	---	85
9-3	8-4	200	0.00	T	0.10	0.08	17.0	7.9	84
	9-15	200							
10-22	10-13	200	1.54	0.00	T	T	9.6	7.6	75
Pond 3									
	1-12	200							
	1-26	200							
	2-10	200							
	3-7	200							
	4-9	200							
	4-22	100							
5-19	5-9	100	0.32	0.00	---	0.00	33.9	---	83
6-2	5-25	100	T	0.00	0.00	0.00	34.3	7.8	84
6-19	6-9	100	0.32	0.00	0.00	0.00	35.2	8.0	84
7-21	6-23	100	0.00	0.00	T	T	34.5	---	85
9-3	8-4	200	0.00	T	T	T	16.3	7.9	84
	9-15	200							
10-22	10-13	200	T	0.05	T	0.01	8.1	8.1	75

Although fertilization was begun Jan. 12, 1953, the first nutrient analysis was not made until May 19, 1953.

Beginning May 19, 1953, estimates were made for dissolved phosphorus and nitrogen in both the fertilized and unfertilized ponds between each application of fertilizer. The results of these determinations are tabulated in Tables I and II as ppm P_2O_5 , ppm nitrogen as the nitrate and ammonia radicals and ppm total dissolved nitrogen as N. In addition salinity, pH, water temperature and the last date of fertilization are given for each pond on the date analyses were made.

TABLE II
Nutrient Analysis of Unfertilized Ponds, 1953

Pond 2 °							
Date	P_2O_5	NO_3^-	NH_4^-	Total Dissolved N	Salinity	pH	Temp.
	ppm	ppm	ppm	ppm	0/00		°F.
5-19	0.00	T	---	T	29.1	---	83
6-2	1.15	0.00	0.00	0.00	31.7	7.9	83
6-19	0.62	0.00	0.05	0.04	35.1	8.1	84
Pond 4							
5-19	0.69	T	---	T	32.1	---	83
6-2	T	0.00	0.00	0.00	33.6	7.9	83
6-19	0.62	0.00	0.00	0.00	35.3	8.0	84
7-21	T	0.00	T	T	34.2	---	85
9-3	0.00	0.10	0.10	0.10	8.7	7.8	84
10-22	0.23	0.05	T	0.01	7.6	8.1	75

° Pond 2 was drained and put in a feeding experiment on July 8, 1953.

DETERMINATIONS

Phosphorus: Phosphorus was estimated by adding standard ammonium molybdate-sulfuric acid, and stannous chloride solutions (A. P. H. A., 1946) to 50 ml. of the water samples and comparing the blue color that developed in the presence of soluble phosphorus with that of like portions of distilled water to which known quantities of phosphorus had been added. A salt correction factor of 1.35 was applied (Harvey, 1945).

Nitrate Nitrogen: Nitrate nitrogen was estimated by the phenol-disulfonic acid method. This method had to be altered somewhat for use in sea water (A. P. H. A., 1946). The nitrites were oxidized to nitrates by the addition of K_2MnO_4 . The chlorides were determined by titration with $AgNO_3$, and sufficient Ag_2SO_4 added to precipitate all but 0.1 mg. chlorides in a 100 ml. sample. The standard method was then followed and the yellow color that developed in the presence of nitrates upon dissolution in strong ammonium hydroxide was compared with like portions of distilled water to which ammonium hydroxide and known quantities of nitrates had been added. The results recorded as nitrates were actually nitrites plus nitrates.

Ammonia Nitrogen: Ammonia nitrogen was estimated by direct nesslerization after treating the samples with a 10% solution of $ZnSO_4 \cdot 7H_2O$ and raising the pH to 10 with a 50% solution of $NaOH$ (A. P. H. A., 1946). The reddish color produced by Nessler's reagent in the presence of ammonia nitrogen was compared with like portions of distilled water to which known quantities of ammonia nitrogen had been added.

Salinity: Salinity was determined by titrating 10 ml. samples with 0.1595 N $AgNO_3$ using K_2CrO_4 as an indicator (Harvey, 1945).

pH: The pH was determined with a model G. Beckman portable pH meter.

Temperature: All temperatures were surface temperatures taken by immersing a mercurial pocket thermometer in the surface six inches of water.

The methods of estimating the dissolved phosphorus, NH_4^- nitrogen and NO_3^- nitrogen limit the accuracy of the determinations, and the tabulated values should not be considered as absolute. In each case standards were prepared at intervals of 0.05 ppm, and comparisons made visually. Concentrations less than 0.05 ppm are indicated in the tables by the symbol T (trace).

RESULTS

The surface temperatures ranged from 75°F. to 85°F. on the days nutrient determinations were made. The low for the entire fertilization period was 43°F. and the high 87°F. The extremes in salinity on the days nutrient determinations were made were

7.6 0/00 in pond 4 to 35.5 0/00 in pond 1. The extremes for the entire fertilization period were 7.6 0/00 in pond 4 to 35.7 0/00 in pond 1. None of the ponds had a pH below 7.6 or above 8.1 on the days nutrient determinations were made. The lowest pH in any pond was 7.5 and the highest 9.4 for the entire fertilization period.

In the fertilized ponds phosphorus was present at least in trace quantities in four of the six determinations. On October 22, 1953, there was 1.54 ppm dissolved phosphorus as P_2O_5 in pond 1. This determination was made during a period of such heavy rainfall that the salinity of the pond water was less than 10 0/00, and the previous fertilization had not resulted in any visible increase in plankton. It should be noted that small amounts of nitrogen were also present in both fertilized ponds on this date, but that in all other analyses where there was a positive P_2O_5 determination no N was evident.

Pond 2, though unfertilized, was not a good unfertilized control. It lay between the two fertilized ponds and had a lower surface level due to low stand-pipe elevation. It is believed these conditions were favorable for a relatively high rate of seepage from the bordering fertilized ponds. Pond 2 was drained following the June 19, 1953, nutrient analysis, but had sustained a very heavy bloom prior to that time. In pond 2 P_2O_5 was in excess on June 2 and June 19, 1953, being 1.15 ppm on June 2.

Pond 4 did not produce a visible plankton bloom, but had much the same appearance throughout the year as the surrounding natural water. The chemistry of this pond is thought to have been representative of these natural waters. In pond 4 P_2O_5 was present at least in trace quantities in four out of six determinations. On June 19 the waters contained 0.62 ppm P_2O_5 . On two occasions dissolved nitrogen, either as NO_3^- or NH_4^+ , as well as dissolved phosphorus gave positive tests; on two other dates only soluble nitrogen was present in detectable amounts.

DISCUSSION

From the foregoing data it would seem that dissolved phosphorus was, in general, present in the fertilized waters in quantities greater than those necessary to maintain the desired N: P_2O_5 ratio. The need for further study is evident, and in subsequent fertilization experiments the per cent N content of the fertilizer will be

increased to yield approximately a 9-9-0 mix. This is certainly an arbitrary increase, but due to the chemical variation of estuarine water exact calculation would be impossible.

The unfertilized ponds contained excesses of P_2O_5 comparable to those in the fertilized ponds. Therefore, the possibility should not be overlooked that a 6-9-0 mix may be correct as a basic salt water fertilizer requiring modification for use in any particular coastal area. That is, it would only be necessary to adjust the N: P_2O_5 ratio according to the relative amounts of nitrogen and phosphorus derived from land drainage.

Fertilizer is applied to water to increase the production of photosynthetic plants. A specific test for the benefits of fertilization would be to measure the relative amounts of these plants in fertilized and unfertilized water. Unfortunately circumstances did not permit such measurements during the experiment. However, in the mullet rearing experiments (results to be reported elsewhere) the best fertilized pond produced 276.8 pounds fish per acre, an increase of 122.4 pounds or 79.3 per cent over unfertilized water.

LITERATURE CITED

A. P. H. A.

1946. Standard Methods for the Examination of Water and Sewage. 6th Edition American Public Health Association, New York.

BALL, ROBERT C.

1949. Experimental Use of Fertilizer in Production of Fish-food Organisms and Fish. Bull. Agri. Exp. Sta. Mich. State Coll., No. 210.

EDMONDSON, W. T., and Y. H. EDMONDSON

1947. Measurements of Production in Fertilized Salt Water. Jour. Mar. Res. 6: 228-246.

GROSS, F., J. E. G. RAYMONT, S. R. NUTMAN and D. T. GAULD

1946. Application of Fertilizers to an Open Sea Loch. Nature, Lond., 158: 187-189.

HARVEY, H. W.

1945. Recent Advances in the Chemistry of Sea Water. Cambridge University Press, London.

PRATT, D. M.

1949. Experiments in the Fertilization of a Salt Water Pond. Jour. Mar. Res. 8: 36-59.

RAYMONT, J. E. G.

1947. A Fish Farming Experiment in Scottish Sea Lochs. Jour. Mar. Res. 6: 219-227.

SMITH, E. V., and H. S. SWINGLE

1938. The Relationship Between Plankton Production and Fish Production in Ponds. *Trans. Amer. Fish Soc.*, 68: 309-315.

SURBER, EUGENE W.

1943. The Effects of Various Fertilizers on Plant Growths and Their Probable Influence on the Production of Smallmouth Black Bass in Hard-water Ponds. *Trans. Amer. Fish Soc.*, 73: 377-393.

SVERDRUP, H. U., M. W. JOHNSON and R. H. FLEMING

1942. *The Oceans*. Prentice-Hall, Inc., New York.

SWINGLE, H. S.

1947. Experiments on Pond Fertilization. *Bull. Agri. Exp. Sta. Ala. Poly. Inst.*, No. 264.

Quart. Journ. Fla. Acad. Sci. 17(2), 1954.

NEWS AND COMMENTS

At a meeting of the Council of the Academy plans for a series of informative monthly broadcasts, entitled "The Academy Speaks," were made. Dr. Donald R. Dyer, Assistant Professor of Geography at the University of Florida, was elected chairman of the Radio Committee in charge of the broadcasts. He will be assisted by the Editorial Board of the Quarterly Journal and by committee representatives in the several colleges and universities that are participating in the series.

The first program was presented over radio station WRUF, Gainesville on May 29, and is being distributed throughout the state by tape-recording. It consisted of a half-hour broadcast, a forum discussion of Florida's future. The participating members were Dr. Sigismond deR. Diettrich, moderator, Professor Henry F. Becker of Florida State University, Dr. Charles T. Thrift, Jr. of Florida Southern College, Dr. H. G. Hamilton of the University of Florida, and Professor E. P. Martinson of the University of Florida. Subsequent programs are designed to be 15-minute length and will be scheduled monthly.

The committee is anxious to present programs that will acquaint the public with important scientific research being carried on by members of the Academy, particularly in regard to Florida. Suggestions will be welcomed. The cooperation of schools with Departments of Radio or Radio Guilds is being secured in order to widen participation in the tape-recorded broadcasts. Attempts have been made to organize a regular circuit of radio stations throughout the state in order to distribute the tapes to all sections.

INSTRUCTIONS FOR AUTHORS

Contributions to the JOURNAL may be in any of the fields of Sciences, by any member of the Academy. Contributions from non-members may be accepted by the Editors when the scope of the paper or the nature of the contents warrants acceptance in their opinion. Acceptance of papers will be determined by the amount and character of new information and the form in which it is presented. Articles must not duplicate, in any substantial way, material that is published elsewhere. Articles of excessive length, and those containing tabular material and/or engravings can be published only with the cooperation of the author. Manuscripts are examined by members of the Editorial Board or other competent critics.

MANUSCRIPT FORM.—(1) Typewrite material, using one side of paper only; (2) double space *all* material and leave liberal margins; (3) use 8½ x 11 inch paper of standard weight; (4) do not submit carbon copies; (5) place tables on separate pages; (6) footnotes should be avoided whenever possible; (7) titles should be short; (8) method of citation and bibliographic style must conform to JOURNAL style—see Volume 16, No. 1 and later issues; (9) a factual summary is recommended for longer papers.

ILLUSTRATIONS.—Photographs should be glossy prints of good contrast. All drawings should be made with India ink; plan linework and lettering for at least ½ reduction. Do not mark on the back of any photographs. Do not use typewritten legends on the face of drawings. Legends for charts, drawings, photographs, etc., should be provided on separate sheets. Articles dealing with physics, chemistry, mathematics and allied fields which contain equations and formulae requiring special treatment should include India ink drawings suitable for insertion in the JOURNAL.

PROOF.—Galley proof should be corrected and returned promptly. The original manuscript should be returned with galley proof. *Changes* in galley proof will be billed to the author. Unless specially requested page proof will not be sent to the author. *Abstracts* and *orders for reprints* should be sent to the editor along with corrected galley proof.

REPRINTS.—Reprints should be ordered when galley proof is returned. An order blank for this purpose accompanies the galley proof. The JOURNAL does not furnish any free reprints to the author. Payment for reprints will be made by the author directly to the printer.

506.73
.F6F43

Quarterly Journal

of the

Florida Academy of Sciences

Vol. 17

September, 1954

No. 3

Contents

Argus and Agnew—Studies of Fluorene Derivatives in Tumor Chemotherapy	129
Fox—The Frustration-Aggression Hypothesis in Corrections...	140
Moody—Adult Fish Populations by Haul Seine in Seven Florida Lakes	147
Grace—A Regional Study of the Phosphate Industry	168
A. A. A. Research Grant	181
Caldwell—Additions to the Known Fish Fauna in the Vicinity of Cedar Key, Florida	182
Notice of Annual Meeting	184

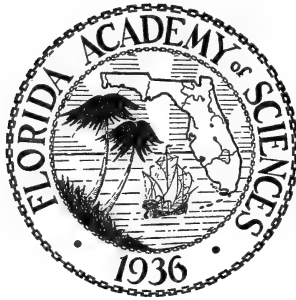

VOL. 17

SEPTEMBER, 1954

No. 3

QUARTERLY JOURNAL OF
THE FLORIDA ACADEMY OF SCIENCES

A Journal of Scientific Investigation and Research

Published by the Florida Academy of Sciences

Printed by the Pepper Printing Co., Gainesville, Fla.

The business offices of the JOURNAL are centralized at the University of Florida, Gainesville, Florida. Communications for the editor and all manuscripts should be addressed to H. K. Wallace, *Editor*, Department of Biology. All subsequent correspondence concerning manuscripts may be handled directly between authors and *associate editors*: J. C. Dickinson, Jr., *Biological Sciences*, Department of Biology and Florida State Museum; Donald R. Dyer, *Social Sciences*, Department of Geography; John W. Flowers, *Physical Sciences*, Department of Physics. Business communications should be addressed to R. A. Edwards, *Secretary-Treasurer*, Department of Geology. All exchanges and communications regarding exchanges should be addressed to The Gift and Exchange Section, University of Florida Libraries.

Subscription price, Five Dollars a year

Mailed October 13, 1954

THE QUARTERLY JOURNAL OF THE FLORIDA ACADEMY OF SCIENCES

VOL. 17

SEPTEMBER, 1954

No. 3

STUDIES OF FLUORENE DERIVATIVES IN TUMOR CHEMOTHERAPY¹

MARY F. ARGUS and L. R. C. AGNEW

The purpose of chemotherapeutic studies in the field of cancer research is to discover an agent which will destroy cancer cells in the host, or so effect these cells that they become vulnerable to the host's own defense mechanisms; while at the same time inflicting no serious injury on normal cells.

Various factors have influenced the selection of chemical compounds for cancer chemotherapeutic studies. Because x-rays can cause the induction as well as the regression of tumors and because many chemical carcinogens have been observed to have an inhibiting effect upon body growth, carcinogenic chemicals have been tested as potential cancer cures; e.g., Haddow (1935, 1938a, 1938b) investigated the possible therapeutic use of a series of structurally related carcinogenic and non-carcinogenic compounds. Since certain derivatives of fluorene are known to produce tumors in various sites in the animal body (Wilson, DeEds, and Cox, 1941; Bielschowsky, 1944, 1947; Morris, Dubnik and Johnson, 1950), it was considered worth while to investigate other derivatives of this molecule as possible tumor chemotherapeutic agents.

Several characteristics of the sulfonamido linkage endow these substances with therapeutic potentialities. So far as could be found in the literature, the work of Ray and Argus (1951) describes the only case of *in vivo* hydrolysis of a sulfonamido linkage and this hydrolysis occurred to the extent of only 0.5 per cent. In addition to localizing in certain tissues (Bloch *et al.*, 1945; Stevens

¹ A contribution from the Cancer Research Laboratory, University of Florida, Gainesville, Florida. This study was supported by grant C-1356 of the National Cancer Institute, U. S. Public Health Service and grant DRIR 101-33B of the Damon Runyon Memorial Fund.

et al., 1950), sulfonamides have been shown to reduce the effective vitamin intake of animals by suppressing the intestinal flora, and this reduction of essential vitamins in the diet of tumor bearing mice is known to inhibit growth of tumors (Boylard, 1938). For these reasons, a disulfonamido derivative of fluorene was studied in the present work. The compound employed was fluorene-2,7-disulfonamido-2'-pyridine (2,7-FDSPy) (Figure 1).

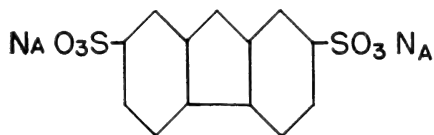

DISODIUM FLUORENE-2,7-DISULFONATE

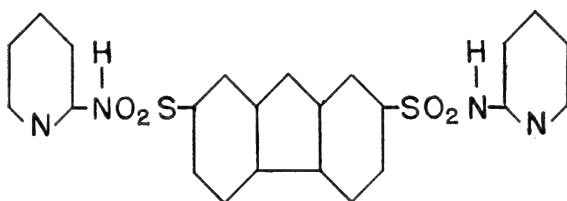

FLUORENE-2,7-DISULFONAMIDOPYRIDINE

Figure 1.—Compounds tested as tumor chemotherapeutic agents.

Disodium fluorene-2,7-disulfonate (2,7-FDS) (Figure 1) was selected for the present investigation since distribution studies with this compound labeled with sulfur-35 revealed a localization of the radioactivity in tumor tissue (Argus, 1953).

MATERIALS AND METHODS

Chemical Compounds:

Disodium fluorene-2,7-disulfonate: Fluorene, 50 gm. (0.3 moles), together with concentrated H_2SO_4 , 69 ml. (1.20 moles) was warmed on a steam bath. After one-half hour the fluorene dissolved. The solution was warmed an additional one and one-half hours during which time a white precipitate formed. Sufficient ice was added

to dissolve the product and the solution was freed of any undissolved residue by filtering. The white disodium salt was precipitated by the addition of a saturated aqueous solution of NaCl. Recrystallization was carried out by dissolving the compound in a minimum of boiling water, filtering hot, adding absolute ethanol until turbid and allowing to cool. Yield, 95.42%. Sulfur analysis gave 17.23% S; the calculated value is 17.31%. The *p*-toluidine salt melted at 326°; the melting point of the disulfonyl chloride was 225-226°; Courtot and Geoffroy (1924) found 225-226° for fluorene-2,7-disulfonyl chloride.

Fluorene-2,7-disulfonamido-2'-pyridine: Fluorene-2,7-disulfonyl chloride, 4 gm., and 2-aminopyridine, 5.15 gm., were dissolved separately in a minimum of hot benzene. The solutions were then combined and refluxed for 3 hours, during which time a light yellow precipitate formed. After cooling, the product was collected, recrystallized from aniline and the resulting white compound washed first with benzene and then with glacial acetic acid. Yield, 95%. Melting point, 309°. Analysis gave 11.69% N and 13.27% S; calculated values are 11.71% N and 13.39% S.

Animal Experiments:

Four to five-week old, male, strain A (Bar Harbor) mice were employed as hosts for the subaxillary transplantation of a keratinizing squamous cell carcinoma (Line A stomach carcinoma originally obtained from the Animal Supply and Research Units of the British Empire Cancer Campaign). A total of 82 of these tumor-bearing mice were divided into groups for three experiments as follows:

Experiment A: To study the effect of a single dose of 2,7-FDS. Solutions were administered by tail vein injection.

Group 1 (12 animals): Received 0.25 ml. normal saline containing 5 mg. 2,7-FDS, one day prior to receiving tumor transplant.

Group 2 (12 animals): Received 0.25 ml. normal saline containing 5 mg. 2,7-FDS, immediately following tumor transplant.

Group 3 (12 animals): Received 0.25 ml. normal saline containing 5 mg. 2,7-FDS, five days following tumor transplant.

Group 4 (12 animals): Received 0.25 ml. normal saline immediately following tumor transplant. (Controls.)

Experiment B: To study the effect of repeated doses of 2,7-FDS. Solutions were administered intraperitoneally.

Group 5 (9 animals): Received five injections, each consisting of 0.25 ml. normal saline containing 5 mg. 2,7-FDS; one injection immediately after tumor transplant, and one at 4, 8, 12, and 16 days after transplant.

Group 6 (9 animals): Received five injections, each consisting of 0.25 ml. normal saline at the same time intervals as for Group 5. (Controls.)

Experiment C: To study the effect of repeated doses of 2,7-FDSPy. Solutions were administered intraperitoneally.

Group 7 (8 animals): Received five injections, each consisting of 0.25 ml. 1% Na_2CO_3 containing 5 mg. 2,7-FDSPy; one injection immediately after tumor transplant, and one at 4, 8, 12 and 16 days after transplant.

Group 8 (8 animals): Received five injections, each consisting of 0.25 ml. 1% Na_2CO_3 , at the same time intervals as for Group 7. (Controls.)

Preliminary toxicity experiments with the doses employed revealed them to be well tolerated by the animals.

Each animal was weighed twice weekly and the dimensions of the tumor measured, horizontally and vertically, with calipers graduated in millimeters. The size of the tumor was recorded on a mimeographed form with the outline of the mouse superimposed on graph paper divided 10 millimeters to the centimeter (Figure 2). Red pencil was used to indicate the areas of ulceration. This gave a permanent record of the location, growth and condition of the tumor through the duration of the experiment.

The animals which had not died after 8 months, were killed by cervical fracture. A complete autopsy was performed on each mouse and the following tissues prepared for histological study: tumor, stomach, lung, liver, kidney and lymph nodes. After fixing in chilled 80% ethanol, paraffin sections, 4-6 μ thickness, were made and the following stains applied: Harris's haematoxylin and eosin, Weigert's fibrin stain, mucicarmine, and the periodic acid-Schiff technique.

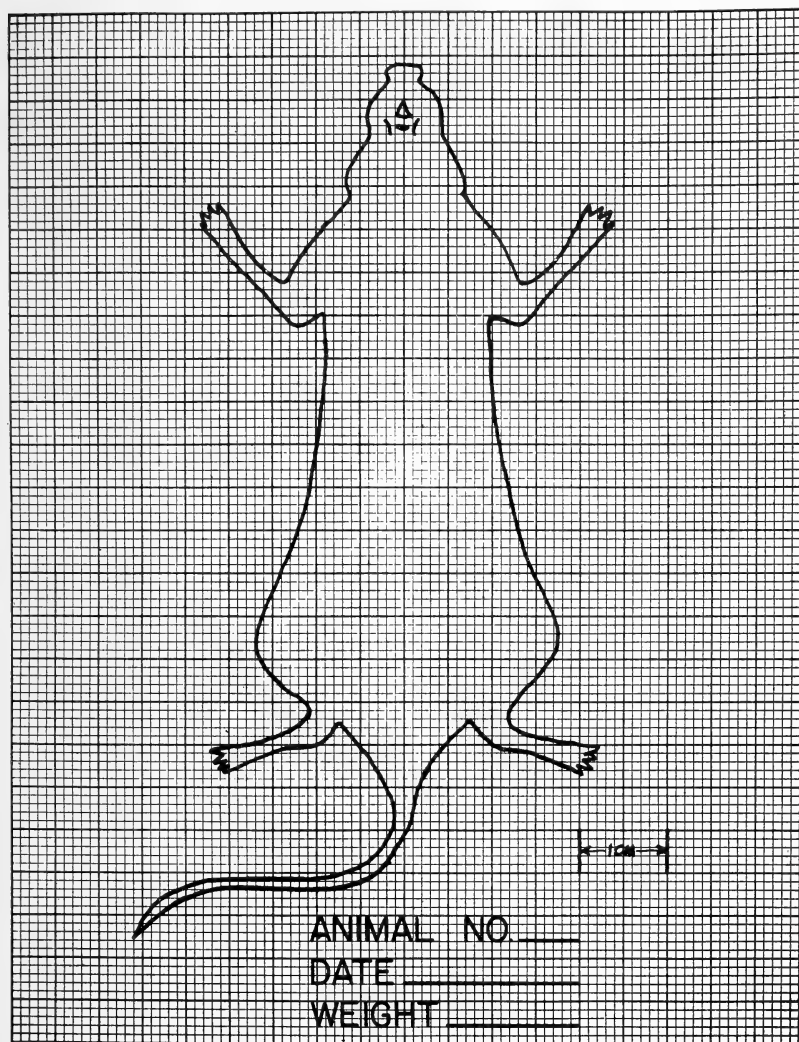

Figure 2.—Graph form used for recording location and size of tumor.

RESULTS

EXPERIMENT A: Effect of a single intravenous dose of 2,7-FDS.

The compound was injected intravenously one day before transplanting the tumor (Group 1), immediately after the transplant (Group 2), or five days later (Group 3). Control animals (Group 4)

were injected intravenously with 0.25 ml. normal saline immediately after receiving the transplant. The transplants "took" in all animals and developed rapidly. The compound had no significant effect on the development and subsequent growth of the transplants, and did not affect the weight or the life span of the mice. After a period of 3 to 6 weeks the tumors of the experimental and control animals tended to ulcerate and to expel a core of necrotic tissue; in a few cases, complete regression of the tumor occurred. Histologically, variable degrees of necrosis, ulceration and secondary infection were observed in those tumors that remained at the end of the experiment. The compound did not seem to influence any of these pathological changes.

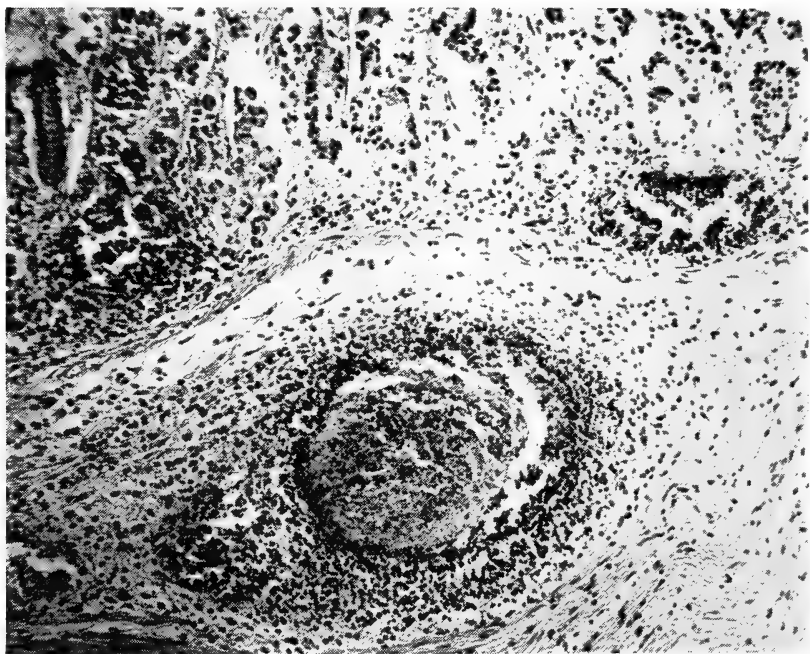

Figure 3.—Section of glandular part of stomach showing two small mucosal abscesses and one large submucosal abscess. Hematoxylin and Eosin. Mag. x 165.

Three well-defined lung metastases from the transplant were observed, one in Group 2 and two in Group 3. Figure 3 shows one of these lesions from a mouse of Group 3. Two other lung lesions,

less clearly defined, were regarded as possible metastases and were found in mice of Group 2. No lung metastases were observed in mice of Group 1, or in the controls (Group 4). This suggests that the 2,7-FDS administered immediately following and five days following transplantation of the tumor might have stimulated metastasis to the lung. This fluorene derivative, which is known to localize in tumor tissue (Argus, 1953), has detergent properties by virtue of its two sodium sulfonate groups. This could possibly have altered cohesion between the tumor cells and facilitated metastasis. The rapid elimination of 2,7-FDS from the animal body (Argus, 1953), could account for the absence of such influence in the mice injected previous to receiving the tumor transplant. On the other hand it should be pointed out that serial sections of lung were not made and it may well be that this lesion was also present in animals of Groups 1 and 4, because only one of the lung metastases found was grossly visible at autopsy.

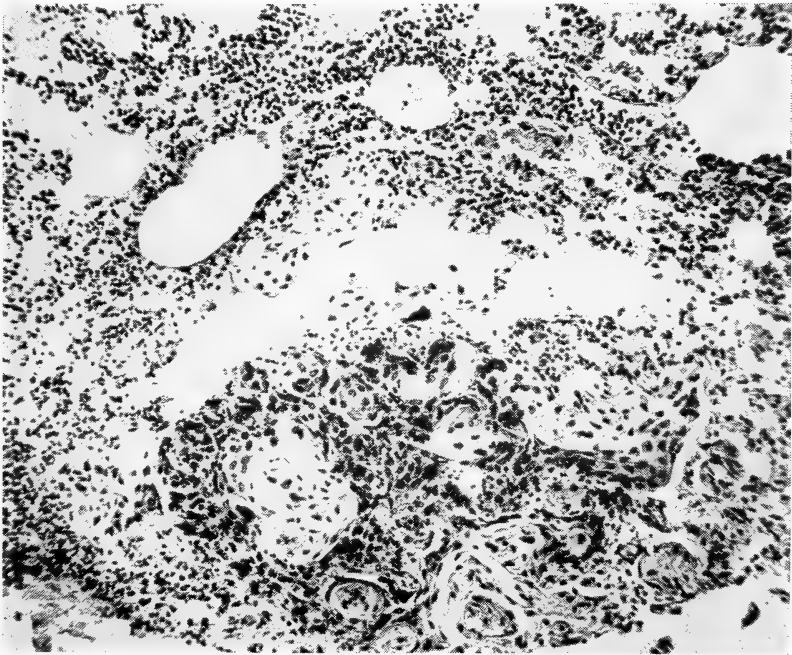

Figure 4.—Section of lung showing metastasis from tumor transplant. Hematoxylin and Eosin. Mag. x 165.

An occasional abscess was observed in the wall of the glandular part of the stomach of experimental and control mice. Figure 4 shows an example of this lesion; two small abscesses are visible in the mucosa, and one large one in the submucosa. In one control



Figure 5.—Section of forestomach showing sessile papilloma with well-marked epithelial "pearl" formation. Hematoxylin and Eosin. Mag. x 165.

mouse, a huge liver abscess was observed that was possibly secondary to abscesses that were also present in the wall of the stomach. It is possible that these abscesses were originally derived from infection of the tumor transplants; as mentioned before, the transplants showed variable degrees of ulceration, infection and necrosis. An occasional focus of round cell infiltration, either at the base of the gastric glands or in the submucosa, was seen in experimental and control animals. Less frequently, similar foci were seen in the lamina propria of the forestomach, particularly near or at the limiting ridge. The significance of these round cell foci is not known. In the forestomach, small papillomas or small papillomatous outgrowths were often found in experimental and control animals.

The compound did not appear to affect the liver grossly or microscopically.

EXPERIMENT B: Effect of repeated intraperitoneal injections of 2,7-FDS.

The results were similar to those observed in Experiment A except that no lung metastases from the transplanted tumors were observed. In the forestomach of one of the control mice (Group 6) a large sessile papilloma was found. At first sight (Figure 5), the presence of epithelial "pearls" or "cell nests" suggested a diagnosis of squamous epithelioma, but the epithelial cells did not appear malignant, nor did they infiltrate through the muscularis mucosae. Marked round cell infiltration was present in the submucosa beneath the affected epithelium. The epithelium was acanthotic but not hyperkeratotic. This apparently benign tumor resembled fairly closely a sessile papilloma obtained by Stewart and Lorenz (1949; Plate 21, Fig. 6 B) who fed mice carcinogenic hydrocarbons in oil emulsions; hyperkeratosis, however, was a feature of their tumor.

EXPERIMENT C: Effect of repeated intraperitoneal doses of 2,7-FDSP_y.

This compound had no significant effect on the development and subsequent growth of the transplants, or on the weight or life span of the mice. The pathological changes observed in the tumor and in the stomach were essentially those already described for Experiment A. No lung metastases, however, were found. In one control

mouse (Group 8) an area of forestomach epithelium showed marked hyperkeratosis, acanthosis, and an increase in size of the rete plugs; this lesion was diagnosed as a sessile papilloma.

SUMMARY

The synthesis of a new compound, fluorene-2,7-disulfonamido-2'-pyridine is described. Repeated intraperitoneal injections of this compound and single intravenous, or repeated intraperitoneal, injections of disodium fluorene-2,7-disulfonate did not inhibit the growth of a transplanted keratinizing squamous cell carcinoma, or the weight or life span of mice bearing this tumor. At least three lung metastases from the primary tumor were observed in experimental animals. Two sessile papillomas of the forestomach were found in control mice. Small papillomas or small papillomatous outgrowths of the forestomach were frequently found in experimental and control mice, all of which bore tumors. Focal infiltration of round cells and, in some cases, actual abscess formation, in the stomach wall was found occasionally in similar control and experimental animals.

ACKNOWLEDGMENTS

The authors acknowledge their gratitude to Mrs. Nell Benjamine, Mrs. Virginia Paul, Mrs. Lois Sumner and Mrs. Zorada Wilkinson for their technical assistance.

REFERENCES

ARGUS, M. F.

1953. Distribution of radioactivity following administration of sulfur 35-labeled disodium fluorene-2,7-disulfonate in mice bearing a transplantable stomach carcinoma. *Brit. J. Cancer*, 7: 273-278.

BIELSCHOWSKY, F.

1944. Distant tumors produced by 2-amino and 2-acetylaminofluorene. *Brit. J. Exptl. Path.*, 25: 1-4.
1947. The carcinogenic action of 2-acetylaminofluorene and related compounds. *Brit. M. Bull.*, 4: 382-385.

BLOCH, H. S., L. SCHIFF, D. E. FLEMING, N. SHAPIRO and H. H. STEINBERG

1945. Gastric excretion of sulfonamides in man. II. Excretion of sulfa-pyridine. III. Calculation of theoretical concentration ratios. *Gastroenterology*, 4: 421-425.

BOYLAND, E.

1938. Experiments on the chemotherapy of cancer. I. The effect of certain antibacterial substances and related compounds. *Biochem. J.*, 32: 1207-1213.

COURTOT, C., and R. GEOFFROY

1924. Sulfonation of Fluorene. *Comp. rend.*, 178: 2259-2262.

HADDOW, A.

1935. Influence of certain polycyclic hydrocarbons on the growth of Jensen rat sarcoma. *Nature*, 136: 868.

- 1938a. The Influence of carcinogenic compounds and related substances on the rate of growth of spontaneous tumors of the mouse. *J. Path. and Bact.*, 47: 567-579.

- 1938b. The influence of carcinogenic substances on sarcoma induced by the same and other compounds. *J. Path. and Bact.*, 47: 581-591.

MORRIS, H. P., C. S. DUBNIK and J. M. JOHNSON

1950. Studies of the carcinogenic action in the rat of 2-nitro, 2-amino, 2-acetylamino, and 2-diacetylamino fluorene after ingestion and after painting. *J. Nat. Cancer Inst.*, 10: 1201-1213.

RAY, F. E., and M. F. ARGUS

1951. Studies on the metabolism, distribution and excretion of 2-p-toluene-sulfonamidofluorene-S³⁵ in the rat. *Cancer Research*, 11: 783-787.

STEVENS, C. D., P. M. QUINLIN, M. A. MEINKEN and A. M. KOCK

1950. Sulfapyrazine precipitated in cancer tissue upon repeated glucose injections. *Science*, 112: 561.

STEWART, H. L., and E. LORENZ

1949. Morbid anatomy, histopathology, and histopathogenesis of fore-stomach carcinoma in mice fed carcinogenic hydrocarbons in oil emulsions. *J. Nat. Cancer Inst.*, 10: 147-165.

WILSON, R. H., F. DeEDS and A. J. COX

1941. The toxicity and carcinogenic activity of 2-acetaminofluorene. *Cancer Research*, 1: 595-608.

THE FRUSTRATION-AGGRESSION HYPOTHESIS IN CORRECTIONS

VERNON FOX
Florida State University

The evaluation of a prison program in terms of success or failure on parole of the men who have been exposed to it is essential to effective progress in penal treatment. The presence of psychologists, social workers, educators, psychiatrists, and other treatment-oriented personnel and programs in a penal setting may be justified only by a high ratio of success to failure of the men to adjust in the free community. The experiment cited in this paper began with the problem of determining the effect of a program of treatment. The psychological, psychiatric, sociological, and educational services were considered to comprise the "treatment program".

In order to obtain a clue as to how to proceed, casual and intensive interviews were held with 100 prisoners over a period of three years from 1948 to 1950, inclusive. Twenty-five of these interviews were made in Michigan's Cassidy Lake Technical School, 25 in the conservation-prison camps, 25 in the trusty division of the State Prison of Southern Michigan, and 25 within the walls of the State Prison of Southern Michigan. The interview was unstructured to allow flexibility so that the prisoners could be put at ease and not feel constrained to emphasize the importance of the treatment program because of the interviewer's identification with it. The purpose of the interview was to identify what major influence on his thinking and adjustment the prisoner had found in his surroundings. Specific reference was made toward the status of the treatment program.

While the influence of the treatment program varied widely in degree of importance as regards influencing adjustment and social attitude, in no instance did it achieve primary importance. The inmates unanimously considered the emphasis in prison treatment to be on the raw social conditioning through being forced to live with other men who had also failed to adjust themselves adequately in our culture. This conditioning was considered to be in the form of learning to suppress aggressive reaction to frustrating social circumstances. This suggests that the frustration-aggression hypothesis as presented by Dollard and his associates may be

operating in the correctional processes (Dollard, 1939). The investigator discussed this point with a group of ten custodial and professional personnel at the State Prison of Southern Michigan and the hypothesis received consensus.

The frustration-aggression hypothesis, according to Dollard and his associates, simply holds that when a person is frustrated, he will react aggressively or find a substitute for aggressive reaction. Aggression is the primary and characteristic reaction to frustration. The strength of the aggression varies directly with the amount of frustration. When aggression, criminal or otherwise, is observed in an individual, its source is frustration. While frustration may also lead to responses other than aggression, the show of violence is considered as conclusive proof of the presence of frustration. Therapy in many cases may consist primarily of ferreting out the source of the frustration.

Whether or not aggression results from frustration depends on the place of aggression in the reacting repertoire of the personality. Previous social experience may have modified the reacting repertoire so that all or most of the available responses are socially acceptable and may not be overtly aggressive. Conditioning by environmental pressures may cause a frustrated person to suppress his aggressions and compensate or rationalize in order to resolve the frustrating circumstances in a manner more socially acceptable than overt aggression. Such a person takes into account some of the expectations and demands of group living, and might be referred to as a well-socialized personality. Swinging the hammer lustily in repairing the porch, deliberated whistling, or ill-concealed insults may be considered higher in the reacting repertoire than overt aggression in such a personality, so that aggression would not result from frustration. If these other responses lead to reduction in the original frustration, the strength to aggression is thereby reduced. The forces which prevent overt aggression in these cases are threats of punishment by physical violence or social and economic pressure, that is to say, any interference in directly achieving the goal-object by overt aggression. This interference is social in nature, and may be considered a socializing medium which promotes tranquil and orderly social living.

On the other hand, aggression is the most readily satisfying response to frustration, provided other serious complications do not

arise. The inhibition of aggression varies directly with the amount of punishment anticipated for the act. If an individual reacts aggressively to frustration, and no undesirable consequences obtain, the strength of instigation to aggression is reinforced. Simultaneously, responses of nonaggression are reduced in strength. A successive extinction of responses of nonaggression leads to the dominance of aggressive reactions.

CRIME AS AGGRESSION

Aggressive action may be operationally distinguished from substitute response. The substitute response may or may not be aggressive, and may not be pointed directly toward the object of the instigating frustration. In either case, aggression is present but may not be overt. Substitute responses merely involve the removal of the interference or the shifts of goals so that the interference may be partially circumvented. Any goal-object has two meanings for the individual. The intrinsic meaning holds satisfaction of achieving the goal-object. The symbolic value, however, becomes primary in many substitute responses, and the intrinsic meaning is relegated to secondary importance.

Many crimes are the result of direct aggression. These offenses occur in persons having generally lower intelligence than the average prison inmate and being less amenable to environmental socializing influences. In the behavior of such persons, there is more direct and less symbolic behavior. In first degree murder, rape, and assaults, the goal-object has direct intrinsic value to the perpetrator. The direct expression of aggression in these instances was higher in the repertoire of responses in the individuals involved than were substitute responses.

Other crimes of less violent nature are still regarded as aggressive in that they hold symbolic meanings of defiance against society's code. Thefts, narcotics violations, homosexuality, and other offenses are perpetrated by individuals with generally higher intelligence than the average prison inmate and with greater sensitivity to social standards. These persons commit non-violent offenses in an attempt to adjust their frustrations without rousing overt and violent hostility between the individuals and society. Aggressive criminal behavior of non-violent nature was higher than the socially accepted substitute response patterns in the reacting reper-

toire of car thieves, burglars, thieves, and persons committing non-violent crimes.

The need to express aggression directly varies with the individual's tolerance to frustration. Persons with low tolerance to frustration need to build up straw men upon whom they may vent their aggressions. Then the aggression can be directed toward a police system, a set of laws, or some other object. Persons with high tolerance to frustration may require severely frustrating circumstances before they react aggressively. It is obvious that there is a direct relationship between tolerance to frustration and ability to live orderly with others. Persons with low tolerance to frustration have frequent quarrels and fights with others. Persons with high tolerance to frustration are more patient and better socialized. Herein lies a crucial point in correctional treatment.

PROCEDURE

After interviewing 100 prisoners and finding that the operation of the frustration-aggression hypothesis was consciously considered to be the primary existing function of the prison program as it relates to the prisoner, the investigator searched for a method to test the operation of the treatment program. Only two of the four groups maintained similar conditions of custody and group living and had varied in their treatment programs. The Cassidy Lake Technical School had minimum-security group living as well as psychological, sociological, and educational services. The conservation-prison camp program had similar minimum security group living, but no psychological, sociological, or educational services. Men were selected for both of these programs similarly except for age and there was considerable overlapping in this factor.

Using IBM equipment, the available social factors of all the men paroled from Cassidy Lake and the conservation-prison camp program prior to January 1, 1950, were tabulated. The Cassidy Lake parolees were matched individually with men from the conservation-prison camp program on the basis of (1) previous jail terms, (2) previous prison terms, (3) previous probations, (4) commitments to juvenile institutions, (5) age, (6) race, (7) length of minimum sentence, (8) urban or rural residential background, (9) marital status, (10) I.Q. within five points either way, (11) grade completed in school, (12) results of academic achievement tests,

and (13) religion. While there were 521 in the Cassidy Lake group and 297 men in the camp group, only 83 men could be individually matched on all the selected social factors. These 83 were compared on the basis of adjustment or failure under parole supervision.

RESULTS

The results of the comparison by the chi-square method of the two groups regarding adjustment on parole show significant differences. With 26.0 men expected by chance from each group to have been successfully discharged from parole, 28 of the Cassidy Lake group were so discharged, while 24 of the prison camp group were successfully discharged. While 27.0 men from each group would be expected by chance to be still on parole, thus far successful, 37 of the Cassidy Lake group were still under successful supervision, while only 17 of the prison camp group enjoyed such status. By chance, 3.5 men from each group would be expected to be on parole with minor restrictions imposed by the parole officers, the Cassidy Lake group and the prison group showed four and three men, respectively, still on parole with such restrictions imposed. A chance expectancy would be that 18.5 men from each group would have been returned to prison as parole violators, but only 8 from the Cassidy Lake group were so returned as compared with 29 returnees from the prison-camp group. By chance, 8.0 from each group would have returned with a new sentence, but Cassidy Lake had 6 returnees with sentences while the prison camp group had 10 new convictions. A chi-square value of 21.721 shows that these differences are statistically significant beyond the .01 level of confidence. The conclusion is, then, that over and above the operation of the frustration-aggression hypothesis, the presence of a treatment program at Cassidy Lake is significantly superior to the lack of such a program in the conservation-prison camp program in terms of success or failure of their respective parolees.

DISCUSSION

Despite differences shown by the presence or lack of a treatment program, the fact remains that 100 prison inmates interviewed regarded that the primary conscious effect of the prison program lay in raising the individual's tolerance to frustration. Penal institutions with or without professional services apparently have much

of their "rehabilitative" method based on the beneficial effects of group living. The advantage of group living is in raising the tolerance to frustration of the individuals in the group. Within the narrow confines of a small group, the conditioning effects of punishment by violence or social pressure will tend to reduce instigation to aggression among individuals in whom overt aggression was previously a primary reaction. In these cases, the substitute responses with greater symbolic than intrinsic meaning tend to be reinforced and raised in the hierarchy of the individual's response patterns. Thus, the tolerance to frustration in the institutional situation is raised. The hope of the prisons' programs is that this raised tolerance to frustration in the institutional situation can be maintained at the raised level and transferred to the civilian community when the individual is released from prison.

If the conditioning effect of group living in the institution could be reinforced to the extent that it would continue after the individual returns to the community, the rehabilitative purpose of incarceration would have been achieved. Continuation of the conditioned response without reinforcement, however, tends to extinguish the response. Institutional controls cannot be transferred to the community. Consequently, the prognosis for this type of treatment alone is not hopeful. The results of the tabulations and computations described in this paper support this thesis. As in experiments in training rats to run a maze for a palatable meal or for dried sunflower seeds, it is observed that the performance of the organism is not motivated in accordance with "learning" alone, but in accordance with the strength of incentive.

In addition to the operation of the frustration-aggression hypothesis, then, there must be incentive or reinforcement to conform to social standards. This conformity may be developed through successful participation in group activities like recreation and occupational pursuits. It may be enhanced by a program of psychotherapy. The resulting social satisfactions and re-orientation may furnish the incentive that will reinforce the beneficial effects of the operation of the frustration-aggression hypothesis. As previously stated, the primary value of group living is the raising of tolerance to frustration by the functioning of the frustration-aggression hypothesis and social conditions. In order to make this raising of the tolerance to frustration lasting, however, the reinforcement by

successful adjustment and re-orientation in the community must be present. It must be encouraged by successful adjustment in a well-rounded psychological, social, recreational, occupational, religious, and educational program in the institution. The prison program must maintain adequate facilities to develop this reinforcement. Only by such complementary incentive can the full benefit of the operation of the frustration-aggression hypothesis in corrections be realized.

BIBLIOGRAPHY

- DOLLARD, JOHN, NEAL E. MILLER, LEONARD DOOB, O. H. MOWRER and R. R. SEARS
1939. *Frustration and Aggression*.
- HYBL, A. R., and ROSS STAGNER
1952. Frustration Tolerance in Relation to Diagnosis and Therapy. *Journal of Consulting Psychology*, 16: 163-170.
- ICHHEISER, GUSTAV
1950. Frustration and Aggression or Frustration and Defense: a Counter-Hypothesis. *Journal of Genetic Psychology*, 43: 125-129.
- McKELLAR, PETER
1950. Provocation to Anger and the Development of Attitudes of Hostility. *British Journal of Psychology*, 40: 104-114.
- MORLAN, GEORGE K.
1949. A Note on the Frustration-Aggression Theories of Dollard and His Associates. *Psychological Review*, 56: 1-8.
- MOWRER, O. H.
1949. Frustration and Aggression. *Encyclopedia of Criminology* by V. C. Branham and S. B. Kutash.
- PASTORE, NICHOLAS
1950. A Neglected Factor in Frustration-Aggression Hypothesis: a Comment. *Journal of Psychology*, 29: 271-279.
1952. The Role of Arbitrariness in the Frustration-Aggression Hypothesis. *Journal of Abnormal and Social Psychology*, 47: 728-731.
- SEARS, ROBERT R.
1951. Symposium on Genetic Psychology: 3. Effects of Frustration and Anxiety on Fantasy Aggression. *American Journal of Orthopsychiatry*, 21: 498-505.

ADULT FISH POPULATIONS BY HAUL SEINE IN SEVEN FLORIDA LAKES

HAROLD L. MOODY

*Florida Game and Fresh Water Fish Commission
Leesburg, Florida*

INTRODUCTION

This study presents an evaluation and comparison of the statics of the principal adult fish populations in several of the larger Florida lakes. The data were gathered in connection with the operation of the State Game and Fresh Water Fish Commission's rough fish control unit under supervision of the author. The lakes are analyzed qualitatively as well as quantitatively in terms of pounds of the several species available to this sampling device and taken in each of the lakes studied. The size distributions within the various species are noted and compared by means of length-frequency studies. The observed physiographic characteristics of the bodies of water are presented; and the relative yields to the net are discussed and compared.

METHODS

Fish were sampled by means of a haul seine varying in length from 750 to 835 yards with a constant minimum mesh size of three inches (stretched), operated by three experienced fishermen and supervised by the Commission's biologist. Equipment consisted of a gasoline-powered launch for pulling the net, two or three fish boats, a seine boat, and the seine. The unit was provided with trucks and trailers to effect its mobility by land. Since the site of operations was often in remote localities, a tent with camping equipment was also included.

The game fishes taken in the operations were released while catfishes were sold dressed, usually to the wholesale fish dealer bidding highest. The other rough fishes: gizzard shad, garfishes, chub sucker, mudfish, stingray, and golden shiner, were destroyed or sold to fertilizer companies. Dressed turtles and gizzard shad roe were sometimes sold to the market for food.

The proceeds from the sale of the fish and fish products were used to help defray the cost of operations—three-quarters of the

total amount went to the fishermen as their pay and the remaining one-quarter was retained by the Commission to aid in paying its operational and maintenance costs.

The dip-net method (Dequine, 1951) was used in estimating total populations of game fishes taken in the seine hauls. Largemouth bass were counted as they were released from each haul, and individuals were weighed at random in order to arrive at the average weight per bass. This average was used as the basis for determining the total weight of bass taken in the haul. The fish removed were weighed.

As many fish as possible were measured at random as time and their abundance permitted. Measuring was done by means of a thirty-inch board graduated at half-inch intervals. The graduations were made in such a manner as to group all measured fishes into inch and half-inch classes. For example: a fish in the 7.5-inch size class is between 7.3 and 7.7 inches total length, inclusive; and a fish in the 8.0-inch size class is within the limits of 7.8 and 8.2 inches, inclusive, etc.

Water analysis was made by means of the Schleicher-Dequine Water Analysis Kit. Dissolved oxygen and carbon dioxide in parts per million were determined by titration with sodium thio-sulfate and sodium hydroxide respectively, and pH was ascertained by the colorimetric method. Air and water temperatures were taken at the surface.

It was inevitable for varying conditions to exist in the operation of the seine, within the same lake as well as from lake to lake. Seldom were any two hauls alike. Weather conditions, bottom characteristics, state of the net, and fishermen's vagaries were some of the factors affecting the area of the haul ground pulled and fishing success.

It is believed that the circumstances which affected fishing success did not bias the data. Therefore: (1) the amounts of fish caught by the rough fish net are considered representative of the populations within the net selectivity in each lake during the period of study, and (2) the populations thus determined for one lake are compared quantitatively as well as qualitatively with those similarly determined in another lake at about the same season of the year. It is admitted that the comparisons may be very approximate ones, but it is felt that within the limitations of the data they are dependable.

The lakes are summarized in terms of average pounds of fish taken per haul during the given periods, and in terms of the percentage composition by weight of each species taken in that average haul.

LAKE ASHBY

Lake Ashby, in Volusia County, has an area of 1,192 acres or 1.86 square miles. It is a shallow saucer-shaped lake with wide sandy beaches in a pine flatwoods region. The average depths in the central area during the period of stay were five to six feet. The water stage was moderately low. Littoral areas were extensive, and consisted partly of sloughs and swamps. The bottom was chiefly of hard sand, although some black mud, varying in depth from about two inches to two feet, was present in a few places. Mussels were observed living on the bottom of the lake in considerable numbers. A light plankton bloom was present in the water at the time of operations. Maiden cane (*Panicum* sp.) grew on the edges of the beach and some eel grass (*Vallisneria americana*) was found in a few areas in the lake. In times of moderately high water Lake Ashby is remotely connected with the St. Johns River by a branch of Deep Creek which flows from Lake Harney and enters Ashby from the south. This branch goes periodically dry when the River is at a low stage. On the west shore a canal drains water from adjacent low flatwoods into the lake. On July 16, 1951 at 10:25 A.M. the water temperature was 90° F. and the air 89° F., the pH 7.0, dissolved oxygen 6.8 ppm, and CO₂ 2.5 ppm.

At the time of operations, in July 1951, available adult fish populations were low: 482 pounds constituted the average haul. The channel catfish (*Ictalurus punctatus*) was the most abundant species; it comprised 41.6 per cent by weight of the catch. The shellcracker (*Lepomis microlophus*) was the next most abundant species: it made up 21.0 per cent of the weight of the catch. Few gizzard shad (*Dorosoma cepedianum*) were taken at the time, and they represented about five per cent of the total weight caught. For other species see Table 1.

LAKE HARNEY

Lake Harney is in Seminole and Volusia Counties, and is part of the St. Johns River. It is an oblong saucer-shaped lake, in a pine flatwoods region, with about 8.73 square miles (5,558 acres)

TABLE 1

Adult Fish Populations in Lakes Ashby, Harney, and Monroe as Determined by Haul Seine Samples.

Name of Waters	Lake Ashby			Lake Harney			Lake Monroe		
County	Volusia			Seminole			Volusia and Seminole		
Approximate Area	1,192 Acres			5,558 Acres			8,814 Acres		
Average Depth Surveyed	3-6 Feet			3-6 Feet			4-7 Feet		
Predominant Bottom Type	Hard Sand			Hard Sand			Hard Sand		
Dates of Survey	July 13-20, 1951			July 26-August 3, 1951			August 17-23, 1951		
Length of Haul Seine	835 Yards			825 Yards			753 Yards		
Minimum Mesh (Stretched)	3 Inches			3 Inches			3 Inches		
Species	Pounds Taken	Average Pounds per Haul	Composition by Percent	Pounds Taken	Average Pounds per Haul	Composition by Percent	Pounds Taken	Average Pounds per Haul	Composition by Percent
Stingray	33	5	1.0	17	2	0.4	116	29	4.7
Mudfish	156	22	4.6	391	49	9.7	88	22	3.6
Longnose Gar	133	19	3.9	19	2	0.5	22	5	0.9
Florida Spotted Gar	164	23	4.9	1,495	184	36.6	1,246	311	50.7
Gizzard Shad	24	3	0.7						
Eastern Chub Sucker	3								
Golden Shiner	1,404	201	41.6	630	79	15.6	192	48	7.8
Channel Catfish	176	24	5.2	21	3	0.5	19	5	0.8
White Catfish	12	2	0.3	4	0.5		2	0.5	0.1
Speckled Bullhead									
Yellow Bullhead	1								
Chain Pickerel									
Warmouth									
Shellcracker	707	101	21.0	92	11	2.3	121	30	4.9
Bluegill	213	30	6.3	201	25	5.0	130	33	5.3
Black Crappie	136	19	4.0	181	23	4.5	160	40	6.5
Redbreast	1			3			10	3	0.4
Black Bass	207	30	6.1	860	107	21.4	237	59	9.6
Croaker				3					
Mullet	1			110	14	2.7	115	29	4.7
Mud Eel									
Totals	3,371	482		4,024	503		2,458	615	
Number of hauls		7			8			4	
Pounds rough fish removed		2,107			2,687			1,800	
Pounds rough fish removed per acre			1.77			0.48			0.20
Predatory turtles	9	1		125	16		22	5	
Non-predatory turtles	1,458	208		588	74		97	24	

of surface area. Littoral areas were large and of the same general character as those of Lake Ashby. The bottom rose gently on all sides to the conspicuous, wide, sandy beaches. At mean low water the average depth in the middle is six feet. The water was at this stage during the period of operations. The bottom was a hard sand, covered in some places by several inches of black mud. Numerous mussels were observed living on the bottom. A light plankton bloom was present in the water. Maiden cane was noted growing near the edges of the shore, and sparse growths of eel grass were found in the lake. On July 26, 1951 at 10:25 A.M. the pH of the water was 7.0; dissolved oxygen 4.20 ppm, and the temperature of the water was 84° F. when the air temperature was 85° F.

Low populations of adult fishes were available to the seine during the period of operations—July 26 to August 23, 1951—only 503 pounds were taken in the average haul. The predominant species found was gizzard shad, which composed 36.6 per cent by weight of the catch. Next in abundance was the largemouth bass, *Micropterus salmoides floridanus* (LeSueur), which represented 21.4 per cent by weight of the catch—the highest percentage found in any of the seven lakes discussed. Channel catfish followed the bass in order of abundance, and comprised 15.6 per cent by weight of the catch. For average weights per haul and additional data see Table 1.

LAKE MONROE

Lake Monroe is a part of the St. Johns River and is bounded by Seminole and Volusia Counties. It is about 13.77 square miles (8,814 acres) in area, saucer-shaped and roughly circular in outline. The margins were gently sloping, with wide sandy beaches and extensive sloughs and marshes, resembling Lakes Ashby and Harney except for the bulkheaded shore on the Sanford side. The depth was fairly uniform—it averaged about seven feet in the middle. The water stage was low during the operational period. The bottom type was predominantly hard sand, but a great deal of black mud was present at the south end. No plankton bloom was noticeable in the water at the time of operations; *Panicum* and *Vallisneria* were present as in Lakes Ashby and Harney. On August 21, 1951 at 8:50 A.M. the pH was 7.0; dissolved oxygen 10.0 ppm; and the water temperature was 86° F. when the air temperature was 86° F.

Lake Monroe, like Lakes Harney and Ashby, yielded low adult fish populations during August 1951—615 pounds were taken in the average haul. The predominant species represented here was the gizzard shad, comprising 50.7 per cent by weight of the catch. Next in abundance, as in Lake Harney, was the largemouth bass, representing 9.6 per cent by weight of the catch. Again as in Lake Harney, channel catfish was third and composed 7.8 per cent by weight of the catch (Table 1).

LAKE JESSUP

Lake Jessup is approximately fifteen miles southeast of Sanford in Seminole County. It is 12.38 square miles (7,922 acres) in size and is roughly crescent-shaped. Jessup is one of the St. Johns Chain of lakes, although it does not lie directly within the River, as do Lakes Harney and Monroe. It is connected to the River by a short channel on the eastern end. This channel is divided by a muddy island. The lake is fed by a number of springs, some of them sulphurous, from its bed as well as from its shores. Littoral areas are very large, although the shore falls off less gently than that of Ashby, Harney, or Monroe. The margins are generally soft: sand and mud, with some shell. The entire eastern half is surrounded by a marshy margin about one-half mile in width which is composed of inlets, sloughs, and creeks. The western half has a more solid shoreline. The bottom of the lake is composed mostly of soft black mud, mixed with some sand, snail shells, and clay. It is not so uniform in depth as Ashby, Harney, and Monroe. At mean low water (the stage found during the unit's stay) the depth varies from three to seven feet. Adjacent to Bird Island, in the middle of the lake, the bottom was of hard sand and sloped up gently to a water depth of about a foot within two hundred feet of the island. The lake was colored with a fairly heavy greenish plankton bloom at the time of operations. Luxuriant grasses and emergents grew along the shallow places near the shore, and there were numerous beds of eel grass in the lake. On September 10, 1951, at 11:45 A.M., the pH of the water was 7.5, the water temperature 84° F. and the air 84° F. Dissolved oxygen was 10.30 ppm, and CO₂ 3.0 ppm.

In Lake Jessup large numbers of fishes were available to the net during the period August 29 to October 9, 1951. The average

weight per haul was 2,318 pounds. Gizzard shad was the dominant species and comprised 48.3 per cent of the total weight of the catch. White catfish, *Ictalurus catus*, was the species second most abundant, and represented 22.2 per cent by weight. Bluegill was third—11.1 per cent; and channel catfish, stingray, longnose gar, black bass, and black crappie followed, respectively, in order of abundance (Table 2).

LAKE PANASOFFKEE

In Sumter County about six miles north of Bushnell lies Lake Panasoffkee with an area of 7.32 square miles (4,685 acres). It is situated in a climax hammock region of many large oaks, hickories, and magnolias, and is surrounded by extensive cypress and saw-grass marshes. Panasoffkee is a kidney-shaped lake directly connected with the Withlacoochee River by the Panasoffkee River, which drains the lake from its west shore. The lake is relatively shallow, and at the time of operations had an average depth of about five feet (a low water stage). The bottom is composed of a deep, soft, yellowish silt. Large dense beds of eel grass were present in the lake and were especially thick and wide at its northern and southern ends, and on the eastern side. Personal observation revealed a pronounced green plankton bloom manifested in the water through the fall, spring, and summer months. The lake supported a dense population of the snail, *Vivipara g.*, and considerable numbers of mussels. The water is derived principally from springs. At the time of operations it exhibited a milky appearance underlying its greenish plankton layer. Littoral areas are extensive, and large beds of giant pickerel weeds (*Pontederia* sp.) figure prominently in the dense vegetation. From the marshy saw-grass ringed shoreline the silty bottom slopes gently to five foot depths. On May 1, 1951 the water temperature was 78° when the air was 75° F., the pH was 8.3, dissolved oxygen 7.6 ppm, and CO₂, zero ppm.

Lake Panasoffkee exhibited high fish populations during April and the first two days in May 1951. The average weight per haul was 3,439 pounds. The species of fish taken most abundantly was the longnose gar, *Lepisosteus osseus*, which represented 34.9 per cent by weight of the catch. Second in abundance was the gizzard shad, composing 30.5 per cent. Shellcracker ranked third—16.3 per cent; and bluegill fourth, comprising 5.4 per cent (Table 2).

TABLE 2
Adult Fish Populations in Lakes Jessup and Panasoffkee and Black Lake as Determined by Haul Seine Samples.

Name of Waters County Approximate Area Average Depth Surveyed Predominant Bottom Type Dates of Survey Length of Haul Seine Minimum Mesh (Stretched)	Lake Jessup			Lake Panasoffkee			Black Lake		
	Pounds Taken	Average Pounds per Haul	Composition by Percent	Pounds Taken	Average Pounds per Haul	Composition by Percent	Pounds Taken	Average Pounds per Haul	Composition by Percent
Stingray	2,190	95	4.1	33	2	0.1	1,250		
Mudfish	1,390	60	2.6	15,628	1,202	34.9	70		73.5
Florida Spotted Gar	233	10	0.4	1,266	97	2.8	125		4.1
Gizzard Shad	25,750	1,119	48.3	13,658	1,051	30.5			7.3
Eastern Chub Sucker				183	14	0.4			
Golden Shiner	3			7					
Channeled Catfish	2,715	118	5.1	113	9	0.3	235		13.8
White Catfish	11,836	515	22.2	18	1				
Speckled Bullhead	123	5	0.2	1,639	126	3.7	5		0.3
Yellow Bullhead				2					
Chain Pickerel				4					
Warmouth				1					
Shellcracker	624	27	1.2	7,272	559	16.3			
Bluegill	5,939	258	11.1	2,400	185	5.4	2		0.1
Black Crappie	903	39	1.7	1,071	82	2.4	10		0.6
Redbreast	1								
Black Bass	1,426	62	2.7	1,413	109	3.2	4		0.2
Croaker	141	6	0.3						
Mullet	49	2	0.1						
Mud Fel									
Totals	53,323	2,318		44,708	3,439		1,701		
Number of hauls		23			13			1	
Pounds rough fish removed		42,099			32,547			1,685	
Pounds rough fish removed per acre			5.31			6.95			4.13
Predatory turtles	80	3		55	4				
Non-predatory turtles	361	16		10,405	800				

An outstanding fact about Lake Panasoffkee was the abundance of the hard-shell turtle or "cooter", *Pseudemys floridana peninsularis*. In no other lake, to the writer's knowledge, was it found so abundantly. A total weight of 10,405 pounds were taken, representing 18.9 per cent of the combined weight of the catch. The weight of the average cooter was about eight pounds.

JOHNS LAKE

Johns Lake is located several miles WSW of Winter Garden in the western part of Orange County and extends into eastern Lake County. It is 4.24 square miles (2,714 acres) in size, very irregular in outline, and is divided into three sections by narrow channels. The easternmost portion is nearly separated from the middle one by an island—Deer Island—and a peninsula—Williams Peninsula. The west section of the lake, known locally as "Clear Lake" because of the transparency of its water (in contrast to the dark colored appearance of that of the other two divisions), is differentiated from the middle section by a second narrowing. The bottom is hilly, rolling, and uneven. Depths in the central portions varied from four to twenty-five feet. Littoral areas were usually small and the shore, in general, had a fairly steep slope. The shoreline was generally high, although there were a few marshy areas where heavy growths of aquatic and emergent vegetation were in evidence.

Chemical and Physical Characteristics

Date	Time	pH	ppm	Temperature °F.	
			Dissolved Oxygen	Water	Air
November 14, 1950	10:00 A.M.	6.2	7.9	69	70
December 14, 1950	8:30 A.M.	6.5	8.2	56	50
March 14, 1951	9:55 A.M.	6.5	7.6	64	49

Except for these scattered areas there was almost no vegetation growing at the shoreline, and none was observed at greater depths. The bottom is composed of sand and black mud with some clay. No plankton bloom was observed in the water at the time, nor was found on subsequent occasions when the lake was revisited. The only body of water with which Johns Lake has any known connection

TABLE 3
Adult Fish Populations in Johns Lake as Determined by Haul Seine Samples.

Name of Waters County Approximate Area Average Depth Surveyed Predominant Bottom Type Dates of Survey Length of Haul Seine Minimum Mesh (Stretched) Type of Haul	Johns Lake Orange and Lake 2,714 Acres 8-12 Feet Mud and Sand March 14-28, 1951 835 Yards 3 Inches Unbaited			Johns Lake Orange and Lake 2,714 Acres 8-12 Feet Mud and Sand Nov. 24-Dec. 28, 1950 825 Yards 3 Inches Baited		
	Pounds Taken	Average Pounds per Haul	Composition by Percent	Pounds Taken	Average Pounds per Haul	Composition by Percent
Species						
Stingray	5	0.3				
Mudfish	1,828	101	4.7	717	80	6.2
Longnose Gar	617	34	1.6	176	19	1.5
Florida Spotted Gar	9,466	526	24.4	1,834	204	15.9
Gizzard Shad	58	3	0.1	36	4	0.3
Eastern Chub Sucker	35	2	0.1	1		
Golden Shiner	16,976	943	43.7	3,377	375	29.3
Channel Catfish	1,563	87	4.0	955	106	8.3
White Catfish	291	16	0.7	937	104	8.1
Speckled Bullhead				12	1.3	0.1
Yellow Bullhead	18	1		6	0.6	
Chain Pickerel	6	0.3		15	2	0.1
Warmouth	51	3	0.1	91	10	0.8
Shellecracker	4,893	272	12.6	2,355	262	20.4
Bluegill	1,409	78	3.6	696	77	6.0
Black Crappie						
Redbreast	1,597	89	4.1	311	35	2.7
Black Bass						
Croaker						
Mullet						
Mud Eel	1					
Totals	38,813	2,156		11,519	1,280	
Number of hauls		18			9	
Pounds rough fish removed		30,838			8,045	
Pounds rough fish removed per acre			11.36			2.96
Predatory turtles				14	1	
Non-predatory turtles	134	7		108	12	
				15,612	2,230	
					7	
					14,466	
						5.32

is Black Lake, about a mile to the east. It is joined to it by a canal draining a marsh between the two lakes.

The seine hauls pulled in Johns Lake are separated into three groups: (1) unbaited ones made at random in the lake during the first period of operations, (2) baited ones made at a single location during the first period, and (3) random unbaited hauls made about two months later.

Random hauls made during the first period yielded high fish populations—the average weight per haul was 2,156 pounds (Table 3). Channel catfish was the dominant species taken, and composed 43.7 per cent of the weight of the catch. Second most abundant was the gizzard shad, 24.4 per cent of the combined weight of populations caught. Third was the bluegill, 12.6 per cent of the total weight. Longnose gar was fourth, largemouth bass fifth, white catfish sixth, and black crappie (*Pomoxis nigromaculatus*) seventh.

In the second period of operations, after a two months lapse of time, random hauls yielded smaller total populations. The average weight per haul had dropped to 1,280 pounds. The dominant species remained the channel catfish, but it comprised only 29.3 per cent by weight of the catch. Bluegill had become the second most abundant species—it represented 20.4 per cent of the weight taken. Third, fourth, and fifth in order of abundance were, respectively, gizzard shad, white catfish, and speckled bullhead. Sixth and seventh were longnose gar and black crappie (Table 3).

Johns Lake was the only lake extensively baited for catfishes included in this study. The purpose of baiting is to attract large numbers to an area. The area should be baited repeatedly so as to accustom them to come there to feed. The haul ground area selected in Johns Lake was baited every day for a week before the first haul was made, and was baited daily and fished about twice a week thereafter. All the gizzard shad, garfishes, and other rough fishes (with the exception of catfishes, no parts of which were used for bait) caught were cooked, salted, and placed in the baited area. Seine hauls were made early in the morning before the "cats" had a chance to leave after eating the bait.

Baited hauls in Johns Lake proved extremely successful. The average weight per haul of all fishes was 2,230 pounds, of which 88.7 per cent by weight consisted of catfishes. The principal species

caught was the channel catfish, which represented 80.5 per cent by weight of the catch. Second was the white catfish, 8.0 per cent; third, the bluegill, 4.9 per cent; fourth, gizzard shad, 3.5 per cent; black crappie, fifth, 1.6 per cent; and black bass, sixth, 0.7 per cent by weight of the total catch. No longnose garfish were caught from baited hauls in Johns Lake (Table 3).

BLACK LAKE

Black Lake lies about a mile east of Johns Lake and is located in Orange County. It was 0.64 square miles (408 acres) in size, and was roughly circular in shape. Littoral areas were wide, the lake was shallow—four to five feet deep in the middle; the bottom was chiefly of sand with some black mud. No plankton bloom was observed on its waters, which like those of most of Johns Lake were dark colored in appearance. Some maiden cane grew along the shoreline, together with pickerel weed and other emergents. There is a large marsh contiguous with Black Lake extending eastward approximately three miles. Black Lake is connected directly with Johns by a canal about a mile long.

A single haul was made in Black Lake. Because of the lake's small size and because the haul was pulled near its central part, it is believed that the sample can be considered representative of the fish populations available to the net on March 30, 1951.

The total weight of all fishes taken was 1,701 pounds: 73.5 per cent of this weight consisted of longnose gar; 13.8 per cent, of channel catfish; and 7.3 per cent of gizzard shad. Black crappie, bluegill, and black bass, jointly, represented only about 0.9 per cent of the total weight of the catch (Table 2).

SIZE DISTRIBUTIONS

Size distributions among the populations of the several species are summarized in Table 4. The average lengths presented were determined from length-frequency data by multiplying the number of fish measured in each size group by the total-length measurement of that size group, summing up the products and dividing by the total number of fish in the sample. Occasionally where average lengths were not available, average weights are presented instead, and in the few cases where data were available the average

weight corresponding to the average length of the species in question is also given. It is regrettable that the volume of work attendant on the supervision of the rough fish unit precluded length-weight studies, particularly for the bass, bream, and crappie, which had to be released alive.

It is believed that the size distributions presented in Table 4 may be considered representative for the populations of the lakes during the periods of study. Large samples were generally taken for analysis, and efforts were made to keep them uniformly random.

COMPARISON

In drawing comparisons from lake to lake it should be recognized that the abundance of fishes available to the haul seine in a given body of water is subject to "seasonal and cyclic fluctuations" (Dequine 1951) caused perhaps principally by fish movements in connection with spawning and feeding activities which lead them to shallow water where the seine cannot go, or even outside the lake itself (H. L. Moody, Unpublished Data). It is apparent, therefore, that bodies of water sampled at about the same time of year should be more readily comparable than bodies sampled at different times. Ashby, Harney, and Monroe are logically comparable in this respect; Panasoffkee is comparable with Black Lake; and, although the sampling in Jessup was done in early fall almost a year after the first period of operations in Johns in late fall, striking over-all population similarities justify their comparison.

Lakes Harney and Monroe, similar type lakes in the St. Johns River, yielded nearly equal yet low average poundages of fishes to the sampling device, and there was a close similarity in their species composition. The three most abundant fishes in the two lakes were respectively, gizzard shad, black bass, and channel catfish. Nearby Lake Ashby, of the same bottom type as the former lakes, yielded about the same total average poundages, but yielded an extremely low shad population. Channel catfish and shellcracker were, respectively, the two most abundant species taken in Lake Ashby.

Lake Panasoffkee and Black Lake are similar in two respects only: (1) the high proportions of garfishes present and (2) the high average poundages taken. The 1,320 pounds of garfishes caught in Black Lake represented 77.6 per cent of the total weight of the

TABLE 4

Minimum, Average and Maximum Sizes of Adult Fishes Caught by Haul Seine in the Seven Lakes. The Lakes Are Listed in Descending Order of Abundance by weight of the Various Species in the Several Lakes.

Species	Lake	Sizes		
		Minimum	Average	Maximum
Black bass (<i>Micropterus salmoides floridanus</i>)	Panasoffkee	7.5 inches	12.84 inches	26.0 inches
	Harney	10.0 inches	14.12 inches	25.5 inches
	Johns	8.5 inches	17.27 inches	27.0 inches
	Jessup	10.5 inches	16.37 inches	24.0 inches
	Monroe	10.5 inches	13.36 inches	21.0 inches
	Ashby Black	8.0 inches	12.05 inches	22.0 inches
Black crappie (<i>Pomoxis nigromaculatus</i>)	Johns	5.0 inches	7.85 inches	11.5 inches
	Panasoffkee	6.5 inches	12.80 inches	15.0 inches
	Monroe	8.5 inches	11.65 inches	13.5 inches
	Jessup	7.0 inches	11.59 inches	15.0 inches
	Harney	8.5 inches	11.74 inches	13.5 inches
	Ashby Black	8.5 inches	10.92 inches	12.5 inches
Bluegill (<i>Lepomis macrochirus</i>)	Johns	4.5 inches	6.56 inches	10.0 inches
	Jessup	4.5 inches	7.88 inches	9.5 inches
	Panasoffkee	5.0 inches	8.37 inches	12.0 inches
	Monroe	5.5 inches	8.07 inches	9.5 inches
	Ashby	5.0 inches	7.19 inches	9.0 inches
	Harney Black	4.5 inches	6.56 inches	9.5 inches
Shellcracker (<i>Lepomis microlophus</i>)	Panasoffkee	6.0 inches	10.37 inches	14.0 inches (3.25 pounds)
	Ashby	5.5 inches	8.26 inches	13.0 inches
	Monroe	8.0 inches	9.18 inches	10.5 inches
	Jessup	5.5 inches	9.76 inches	12.0 inches
	Harney	7.5 inches	9.26 inches	11.5 inches
	Johns Black	-----	-----	-----
Channel catfish (<i>Ictalurus punctatus</i>)	Johns	8.5 inches	16.26 inches	41.0 inches
	Black	-----	-----	-----
	Ashby	9.5 inches	14.90 inches	34.0 inches
	Jessup	10.0 inches	18.46 inches	36.0 inches
	Harney	9.5 inches	12.36 inches	22.0 inches
	Monroe Panasoffkee	-----	4.31 pounds	27.0 inches (9.0 pounds)
White catfish (<i>Ictalurus cactus</i>)	Jessup	10.0 inches	12.69 inches	15.5 inches
	Johns	9.5 inches	11.08 inches	13.5 inches
	Ashby	9.5 inches	10.96 inches	15.0 inches
	Harney	-----	-----	-----
	Monroe	-----	-----	-----
	Panasoffkee Black	-----	13.50 inches	(1 fish)

TABLE 4—(Concluded).

Species	Lake	Sizes		
		Minimum	Average	Maximum
Speckled bullhead (<i>Ameiurus nebulosus marmoratus</i>)	Panasoffkee	14.5 inches	16.21 inches (2.6 pounds)	18.0 inches
	Ashby	9.5 inches	14.50 inches	16.0 inches
	Johns	-----	14.50 inches (1.14 pounds)	16.0 inches
	Jessup	-----	1.75 pounds	-----
	Monroe	-----	1.70 pounds	-----
	Harney Black	-----	2.00 pounds	-----
Longnose gar (<i>Lepisosteus osseus</i>)	Black	-----	11.26 pounds	-----
	Panasoffkee	-----	9.72 pounds	-----
	Johns	-----	13.99 pounds	-----
	Jessup	-----	11.80 pounds	-----
	Harney	-----	13.96 pounds	-----
	Monroe	-----	8.32 pounds	-----
	Ashby	-----	8.56 pounds	-----
Florida spotted gar (<i>Lepisosteus platyrhinchus</i>)	Panasoffkee	-----	1.50 pounds	-----
	Black	-----	-----	-----
	Johns	-----	2.27 pounds	26.5 inches
	Ashby	-----	1.15 pounds	-----
	Jessup	-----	2.09 pounds	-----
	Monroe	-----	2.75 pounds	-----
	Harney	-----	2.38 pounds	-----
Gizzard shad (<i>Dorosoma cepedianum</i>)	Jessup	-----	-----	-----
	Panasoffkee	7.0 inches	12.58 inches	16.5 inches
	Johns	6.5 inches	9.07 inches	15.0 inches
	Monroe	-----	-----	-----
	Harney	8.0 inches	15.71 inches	18.0 inches
	Black Ashby	----- 9.0 inches	----- 12.92 inches	----- 18.0 inches
Yellow bullhead (<i>Ameiurus natalis</i>)	Johns	-----	0.67 pounds	-----
	Panasoffkee	-----	2.00 pounds	-----
	Ashby	-----	1.00 pounds	-----
	(None were caught in the remaining four lakes)			
Eastern chub sucker (<i>Erimyzon sucetta sucetta</i>)	Panasoffkee	-----	1.74 pounds	-----
	Johns	-----	1.54 pounds	-----
	Ashby	-----	1.20 pounds	-----
	(None were caught in the remaining four lakes)			
Mudfish (<i>Amia calva</i>)	Ashby	-----	4.13 pounds	-----
	Panasoffkee	-----	4.76 pounds	-----
	Harney	-----	4.25 pounds	-----
	Johns	-----	2.30 pounds	-----
	(None were caught in the remaining three lakes)			
Chain Pickerel (<i>Esox niger</i>)	Johns	-----	2.50 pounds	-----
	Panasoffkee	-----	3.38 pounds	-----
	(None were caught in the remaining five lakes)			

catch, while in Panasoffkee the average weight per haul of 1,299 pounds of garfishes amounted to only 37.7 per cent of the total weight. In Black Lake the garfishes greatly outweighed all the other species caught, while in Panasoffkee they represented about one-third of the total weight.

Lake Jessup (August-October 1951) and Johns Lake during the first period (November-December 1950) produced about the same total average poundages of fishes to the haul. The two principal species, in order of abundance by weight, were gizzard shad and white catfish in Jessup, and channel catfish and gizzard shad in Johns Lake. In both lakes bluegill, longnose gar, and black bass represented the next most important segments of the populations. The removal of 16.68 pounds of rough fishes per surface acre of water from Johns Lake (Table 3) during November and December 1950 may have accounted for the decline in the average catch per haul in March 1951, since this decline was nearly identical with the decline in the average pounds taken per haul of rough fishes, and the average weight per haul of game fishes taken showed an increase during the second period (Table 5). However, the cyclic, seasonal fluctuations of abundance previously mentioned cannot

TABLE 5
Comparisons of Poundages of Fish Taken During Two Periods of Stay in Johns Lake.

	November 15 - December 28, 1950	March 14-28, 1951	Differences
Average weight per haul— all fishes (includes baited and unbaited hauls) -----	2,177 pounds	1,280 pounds	897 pounds (decline)
Average weight per haul— rough fishes removed: prin- cipally channel catfish, white catfish, gizzard shad, and garfishes -----	1,812 pounds	894 pounds	918 pounds (decline)
Average weight per haul— game fishes taken: prin- cipally bass, crappie, blue- gill, and shellcracker -----	365 pounds	386 pounds	21 pounds (increase)

be ruled out, and the over-all catch decline might, on the other hand, not have been due to fish removal.

A comparison of baited hauls with unbaited ones (Table 3) made over the same period of time discloses almost equal total average poundages per haul. Baited hauls, however, proved highly selective for catfishes—they comprised nearly 90.0 per cent of the total weight of the catch, while less than 50.0 per cent by weight were taken from the unbaited hauls.

Comparisons of the average sizes of fish in the several lakes are drawn with a recognition of their static nature. The samples were not taken concurrently, the factor of growth is ignored, and fish movements due to seasonal spawning and feeding activities are not taken into account. Nevertheless certain facts brought out by Table 4 are interesting.

In Lake Panasoffkee nine of the fourteen species of fish for which measurements are available were of larger average sizes than those found in any of the other lakes discussed. Shellcracker were taken more abundantly in Lake Panasoffkee than elsewhere, and their average size was much greater. Black crappie, bluegill, white catfish, speckled bullhead, yellow bullhead, chub sucker, mudfish, and chain pickerel were also of larger average sizes in Lake Panasoffkee. Seven of these nine species, viz., black crappie, shellcracker, speckled bullhead, yellow bullhead, chub sucker, mudfish, and chain pickerel held either first or second place in order of abundance by weight in the catches from the seven lakes.

DISCUSSION

Certain salient features of the data will be underlined in this section and they will be commented upon as occasion arises.

The haul seine is doubtless the most efficient instrument in existence for sampling adult fish populations in the large shallow Florida lakes with relatively level bottoms. However, an inspection of Tables 1, 2, and 3 will reveal certain obvious limitations: (1) the seine does not yield adequate quantitative samples of the populations of those fishes whose habitat is limited mainly to the peripheral areas of the water—warmouth, redbreast, mudfish, and several other species; and (2) when the sampling is not carried on over a protracted period of time it is possible for dispersal or schooling to result in low or high catches which are not representa-

tive of the true value of the productivity, or of the size of the populations of a given body of water.

Low catches in Lakes Ashby, Harney, and Monroe during July and August 1951 could be illustrative of the latter case. It is interesting to note by comparison that during the period of the "Controlled Seining Program" in Lake Crescent (July 1952 to February 1953) the average catch per haul was similarly low in July, August, and September, but more than tripled in weight during the months of November, December, and January (Dequine 1953). It seems extremely probable, therefore, that had the sampling continued over a longer period in Ashby, Harney, and Monroe similar catch increases would have become evident.

Schoolings and dispersals of fish in Florida's fresh waters cannot be predicted since their causes are not definitely known, but directed and integrated investigation cannot fail to uncover these secrets. Tagging studies now in progress should do much to determine whether fish leave or enter lakes in large numbers, or, alternately, whether they merely move into and out of areas of availability within them.

The close correspondence in average pounds per haul, and in the species composition of the catch in Harney and Monroe suggest that the linkage of these lakes by the St. Johns River might be the cause of a homogeneity in their populations.

Interesting differences in the populations of the several lakes raise many unanswered questions. Why, for example, was the population of Johns Lake composed principally of channel catfish, when catfishes of all species were extremely scarce in Panasoffkee? Was the tremendous abundance of the hard-shelled cooter in Panasoffkee associated with the presence of huge beds of eel-grass? Could the marsh contiguous with Black Lake be a factor contributing to its large garfish population? What reason could be advanced to explain the large sizes of the fish in Panasoffkee? Why did Lake Jessup yield large poundages of fish to the unit haul while nearby lakes in the same chain yielded low poundages? Why was the gizzard shad scarce in Lake Ashby, when in all the other lakes, with the exception of Black Lake, it came close to being the dominant species?

Nearly all these lakes have an admitted past history of commercial seining and, in some, rumor has it continuing illegally at the time of this writing. Needless to say it is not possible to secure

data from such operations. Perhaps significant changes have been brought about by large scale "manipulations" of the populations. If the past history of these and other lakes were definitely known a great contribution would have been made toward intelligent management of Florida's fresh water fishing.

Johns Lake is the only lake in this study from which rough fish were removed by haul seine where it was possible to return at a later period and compare results. After removing 45,384 pounds of rough fish (chiefly channel catfish), or 16.68 pounds per acre of total water surface (Table 3) the net left at the end of December 1950 and returned two and one-half months later. It was found that the average catch per haul was reduced to nearly one-half that of the first period, and that the combined weight of rough fishes per average haul was also reduced by about one-half (Table 5). Here the net appeared astonishingly effective in reducing the populations of rough fishes. The slight rise in average weight per haul of game fishes is probably not significant as a real increase since insufficient time had elapsed between the two periods for reproduction to occur.

CONCLUSION

The haul seine is a useful and efficient tool for sampling adult fish populations in shallow level bottom Florida lakes. In five of the seven lakes discussed, garfishes and gizzard shad constituted about half or more of the total weights of the populations taken. In all seven of the lakes, rough fishes, including catfishes, composed sixty per cent or more of the total weight of the catch.

SUMMARY

Fish population studies were made by the author in Lakes Ashby, Harney, Monroe, Jessup, Panasoffkee, Johns Lake, and Black Lake by means of a rough fish removal unit employing a haul seine of about 800 yards in length, deep enough to fish the bottom, and with a minimum mesh size of three inches, stretched measure. The minimum average water depth in which the net was used was about three feet, and the maximum twelve. The mesh size permitted no fishes smaller than those of the size of bluegills of 4.5 inches in total length to be taken.

Harney and Monroe in the St. Johns River chain yielded low fish populations. Gizzard shad made up the bulk of the catch

in both lakes. Lake Ashby also yielded low populations; channel catfish and shellcracker were the more abundant species. Lake Jessup, connected with the St. Johns River, was found to have high populations, but about fifty per cent of the catch was gizzard shad, and about twenty-seven per cent catfishes. Lake Panasoffkee hauls revealed high fish populations, but about seventy per cent of the catch was composed of rough fishes, principally gizzard shad and garfishes. Despite this fact the average sizes of the individuals of numerous species, particularly the shellcracker, were larger than those found in the other lakes. The hard-shelled cooter, *Pseudemys*, was taken in very large numbers. The fish populations in Johns Lake were dominated by the channel catfish and the gizzard shad. Baiting a haul area for catfishes was practiced with considerable success. A check on the effectiveness of the rough fish removal here was made possible by a re-entry two and one-half months later. The catch of rough fish was found reduced by one-half. In Black Lake more than seventy-seven per cent of the total weight of the populations taken consisted of garfishes, and about one per cent of gamefishes.

LIST OF SPECIES TAKEN

FISHES:

- Stingray: *Dasyatis* spp.
 Mudfish: *Amia calva* Linnaeus
 Longnose Gar: *Lepisosteus osseus* (Linnaeus)
 Florida Spotted Gar: *Lepisosteus platyrhinchus* DeKay
 Gizzard Shad: *Dorosoma cepedianum* (LeSueur)
 Eastern Chub Sucker: *Erymyzon sucetta sucetta* (Lacépède)
 Golden Shiner: *Notemigonus crysoleucas bosci* (Cuvier and Valenciennes)
 Channel Catfish: *Ictalurus punctatus* (Rafinesque)
 White Catfish: *Ictalurus catus* (Linnaeus)
 Speckled Bullhead: *Ameiurus nebulosus marmoratus* (Holbrook)
 Yellow Bullhead: *Ameiurus natalis* Jordan
 Chain Pickerel: *Esox niger* LeSueur
 Warmouth: *Chaenobryttus coronarius* (Bartram)
 Shellcracker: *Lepomis microlophus* (Gunther)
 Bluegill: *Lepomis macrochirus purpurescens* Cope
 Black Crappie: *Pomoxis nigromaculatus* (LeSueur)
 Redbreast: *Lepomis auritus* (Linnaeus)

Black Bass: *Micropterus salmoides floridanus* (LeSueur)

Croaker: *Micropogon undulatus* (Linnaeus)

Mullet: *Mugil* spp.

AMPHIBIANS:

Mud eel: *Siren lacertina* Linnaeus

REPTILES:

Florida cooter or "Hard-shelled" Turtle: *Pseudemys floridana peninsulari* Carr, and other spp.

Southeastern Soft-shelled Turtle: *Amyda ferox* (Schneider)

ACKNOWLEDGMENTS

The writer wishes to express gratitude to William M. McLane and Melvin T. Huish of the Florida Fish Management Division for encouragement and advice in the preparation of the manuscript, and to Eva M. Bryan, who did the typing and offered many helpful suggestions.

LITERATURE CITED

DEQUINE, JOHN F.

1951. Fisheries Investigations of the St. Johns River and Lake Okeechobee, 1948-50, with Recommendations for Management. Fla. Game & Fresh Water Fish Comm., 48 pp; 7 tables; 5 figs.; 1 form. (Mimeographed.)
1953. Preliminary Progress Report on Florida's Controlled Seining Program, 1 April 1952 through 28 February 1953. A Report to the Director and Members of Fla. Game & Fresh Water Fish Comm. Fla. Game & Fresh Water Fish Comm., 31 pp.; 4 tables; 6 figs. (Mimeographed.)

A REGIONAL STUDY OF THE PHOSPHATE INDUSTRY

H. T. GRACE

Florida Southern College

Phosphorus is necessary to support all plant and animal life. It is very alarming then to observe that the amount of phosphorus in most soils in the United States is being depleted at a far greater rate than it is being replaced. Recent calculations report that a ton of wheat extracts from the average soil 17 pounds of nitrogen, 18 pounds of phosphoric acid, and 12 pounds of potash (Jones, 1941, p. 91). Unless these nutritive elements (or materials) are replaced the fertility of the soil is decreased. To replace the annual loss of elemental phosphorus from crop and pasture lands (estimated at 1,365,000,000 acres) would require the phosphate from between 10 and 20 million tons of average-quality phosphate rock.

The heavy demands placed upon the phosphate industry by the ever-increasing need for fertilizer production, which replenishes our depleted soil, has been one of the chief factors responsible for the rapid growth of this industry.

Since 1940 the total production of phosphate mineral has more than doubled. In recent years the phosphate demands of the fertilizer industry consumed 85% of the annual production in this country. The remaining 15% is used in processing of foods, feed for animals, water softening, in chemical, textile, plastic, petroleum, and other industries (Jacobs, 1950, p. 29).

In trade circles phosphate is known as tricalcium phosphate or bone phosphate of lime (B. P. L.). Over 90% of the phosphate rock used in the fertilizer industry is treated with sulphuric acid, which converts it into superphosphate or triplephosphates. The former usually contains from 18 to 20 per cent of phosphoric acid and the latter grades contain from 43 to 48 per cent. The latter concentration thus reduces the transportation costs by one-half. One long ton of phosphate rock with 74% of bone phosphate of lime, equivalent to 33.9% of phosphoric acid, would make almost two short tons of superphosphate, containing 20% of phosphoric acid.

Aside from the phosphate itself, the normal superphosphates of contemporary commerce contain such plant nutrients as potassium,

magnesium, sulphur, manganese, and calcium, the latter in substantial quantity. Mehring estimates that over one and a half million tons of calcium is furnished each year to the soil of this country through the use of phosphate rock (Mehring, 1948, p. 12).

Almost 50% of the world's supply of phosphate comes from one small region located in the west-central part of peninsular Florida (Fig. 1). The deposits of this region in Polk and Hillsborough Counties are well suited to the use of modern mining methods. Few mining enterprises in North America have made more technological progress for the extraction of mineral resources than the large-scale operations of the pebble phosphate district in Florida.

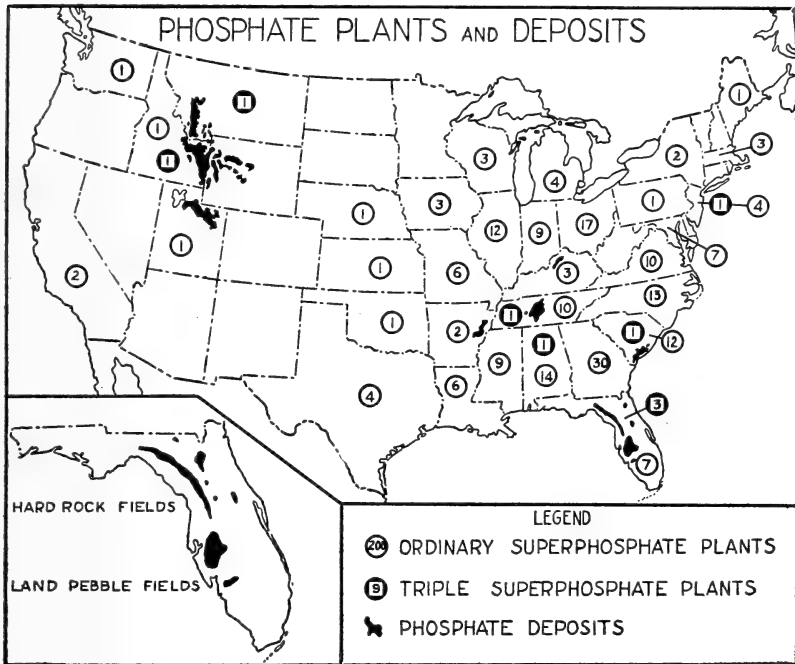

Figure 1.

During the past decade, the discovery that Florida pebble phosphate deposits contain small amounts of uranium was responsible for an intensive study in this region by the U. S. Geological Survey. The Federal Government has recently approved processing plants

for this valuable by-product. These new plants, estimated to cost several million dollars, have been constructed near Bartow, Polk County, Florida, by some of the largest phosphate companies of this area. No doubt the construction of these plants will stimulate greater mining activity in phosphate rock during the next few years in this region.

The market fluctuations in prices of phosphate rock have followed in a general way the five major periods of economic development, being influenced partly by competition from foreign sources. Prices dropped from \$8.00 per ton in 1870 to their all-time low, \$2.50 per ton, in 1898. Since 1947 the price of phosphate rock has risen to an average of over \$5.00 per ton. In the domestic and foreign markets the pebble phosphate of Florida usually sells for fifty cents to one dollar per ton under the same grade of Tennessee and Idaho phosphate, because of their cheaper methods of mining and slightly higher content of iron and aluminum.

Export trade has formed an important part of the domestic phosphate industry. Prior to 1900 over 40% of the total production was for export markets. The South Carolina region furnished nearly all of the shipments abroad prior to 1892. The all-time low in exports occurred in 1918 during the war period when only 6% was shipped abroad. Taking the total output into account more than 25% has been exported since 1867. In recent years, however, less than 15% has been sold in the foreign market with the pebble phosphate region of Florida furnishing over 90% of all U. S. exports.

The number of workers employed in the extraction of phosphates reached its all-time high in 1892, with a total of 9,175, of whom 5,242 were employed in South Carolina, 3,915 in Florida, and 15 in North Carolina (Wright, 1896, p. 106). The second highest period of employment occurred in 1909 when over 7,900 workers were used. With improvement in equipment, however, a rise in output per man took place alongside a long continued drop in workers employed. During the depression period of 1932, when output fell off, only 1,900 men held jobs. Even in 1954, with production at its highest level, only about 4,800 men were required. Two factors account for this rapid decline in the number of workers employed. First, the almost complete mechanization in Florida and Tennessee regions; second, the recovery of much higher percentage of phosphate mined.

PERIODS OF DEVELOPMENT OF THE PHOSPHATE INDUSTRY
IN THE UNITED STATES

The life span of this country's phosphate rock industry can be divided into five distinct periods. Each has its own peculiar characteristics, reflecting the new inventions, mining methods, economic and financial conditions, and methods of exploitation adapted to regional differences in the geologic and geographic factors distinguishing the different areas.

The first period, from 1867 to 1880, was one of steady growth in the amount of phosphate rock mined annually. All of the operations during this period were limited to the South Carolina deposits, where use was made of small dredges, scrapers, and wheelbarrows in mining the ore.

During the second period, 1881 to 1900, the rich deposits of Florida and Tennessee were brought into competition with South Carolina operations. Land deposits came into production with the aid of small steam shovels and suction pumps, with the result that river-mining operations declined.

The third period, from 1900 to 1920, ushered in further improvements in the mining of land deposits by hydraulic methods. The development of a deep-water harbor by the U. S. Government at Tampa, Florida, gave the rich pebble deposit a great advantage in cheap transportation for domestic and foreign export because of the proximity of the mining operations to a deep-water port (Fig. 2). Electrical power was used for pumping the "matrix", consisting of clay, sand, ore-pebbles, and water to the separation plant. Discovery of western deposits took place during this period, and mining operations were begun there in 1906 on a small scale.

Prior to 1900 considerable quantities of Florida phosphate rock were shipped abroad to German chemical plants, for processing into fertilizer, and was later sent back to Atlantic Coast ports for distribution to American farms.

The fourth period, 1920 to 1940, saw great fluctuations in the mining of phosphate, due to alternating prosperity and depression. Extensive operations in the rich North African phosphate area, moreover, built up considerable competition in the foreign market during this period. Introduction of the electric dragline, and discovery and perfection of the oil-flotation process in later years,

resulted in much cheaper production and in the recovery of a much larger per cent of the phosphates actually mined than formerly.



Figure 2.—Loading phosphate at the deep water port, Tampa, Florida.

The last period, from 1940 to the present time, witnessed the development of a settling-pond process, which recovered phosphates from waste slime. Mammoth electrical draglines were introduced, resulting in greater efficiency, but requiring larger investments. This was a burden which many of the smaller companies could not readily carry; accordingly, many consolidations resulted (Fig. 3).



Figure 3.—The matrix (ore) of pebble phosphate in foreground with overburden removed.

Since commercial production of phosphate started in the United States in 1867, over 194 million long tons had been mined by 1950. Of this amount 72% came from Florida, 18% from Tennessee, 7.5% from South Carolina, and 3.5% from the western states.

The known deposits of phosphate rock that give promise of economic importance in the United States are located in Florida, South Carolina, Virginia, Tennessee, Kentucky, Arkansas, Idaho, Montana, Wyoming, and Utah. The occurrence and quality of these phosphate rock deposits varies somewhat in each of the states where they have been examined.

GEOLOGICAL OCCURRENCE OF PHOSPHATE ROCK

“Phosphate Rock” is a general term applied by common usage to rocks of diverse origin, character and occurrence that contain phosphorus. These rocks, whether phosphatized limestone, sandstone, or shale, may exist in consolidated or unconsolidated forms. The numerous types of phosphate rock range from soft marl and sand to hard, massive flint-like rock, varying in color from white to tan or coal-black.

Because of the variable mineralogical content and the variable proportions of the minerals present, phosphate rocks do not have a uniform chemical composition. Chemical analyses show a great predominance of calcium and phosphorus present in the “matrix”

(ore), usually reported as calcium oxide (CaO) and phosphoric oxide (P_2O_5) (Johnson, 1944).

Fluorine is a constituent of all types of domestic phosphate rock. It ranges from 3 to 4 per cent in quantity, and from this source we obtain a large part of our commercial supply. The phosphate deposits of the United States are estimated to contain more than 400 million tons of fluorine. Iron and aluminum are the two most objectionable impurities. Phosphate rock containing more than 6% of these two elements is unsuitable for the manufacture of superphosphates.

The phosphates of Idaho, Montana, Utah, and Wyoming occur in marine sedimentary deposits chiefly of the Permian system, but include also some rock of the Mississippian system. Most of the deposits have been subjected to intense folding, faulting, and erosion. Consequently, bands occur along the flanks of the larger and simpler folds, in the more complex crumplings in the smaller folds, and along the borders of faulted areas. In some places, the Permian phosphate formation occurs in separate layers with several feet of phosphatic sandstones and shales in between.

In other areas the development of commercial deposits resulted from a favorable intervention of various geological processes. These processes concentrated the original low-grade phosphate into workable deposits along the Atlantic Coast and the Gulf of Mexico. The subaerial weathering and leaching, as well as wave action, were the chief processes that redeposited most of these secondary deposits during the Pliocene Epoch (Cathcart, 1950, p. 6).

REGIONAL PHOSPHATE DEPOSITS AND INDUSTRIAL DEVELOPMENT OUTSIDE FLORIDA

Commercial production of phosphate rock in the United States started in South Carolina in 1867. This region for the next twenty-one years supplied nearly all of the United States' output. The deposits are located about ten miles from the coast in a strip not more than twenty miles wide in the vicinity of Charleston. They extend from the Wando River on the north to the Broad River on the south for a distance of seventy miles. The phosphate industry of South Carolina was employing 2,500 workers by 1880 and that year produced 210,000 tons of phosphate rock. Two types of phosphates were worked there—landrock and riverrock.

The landrock occurs in a more or less irregular bed which represents the undisturbed phosphatized *Edisto* marl of the Miocene formation. The South Carolina deposits were believed to have been deposited under similar conditions to the pebble phosphate deposits of Florida.

South Carolina's landrock deposits occur in beds, usually 8 to 16 inches thick, but in places as much as 30 inches, and are ordinarily covered by less than 15 feet of sand, clay, and marl. The river-rock is believed to consist, in part, of the original phosphatized marl and of fragments derived from land deposits and concentrated in and along the river beds.

Landrock deposits were mined from 1867 to 1925, and riverrock from 1870 to 1910. The South Carolina ores were not as rich and extensive as the pebble fields of Florida. Two serious setbacks in the early part of the 1890s resulted in the ultimate loss of the industry's foreign market, which was taken over by the Florida operators. The exporting operators in South Carolina moved their operations to the Florida pebble-phosphate region due to lengthy court litigation over taxes (Rogers, 1914, p. 207). The state of South Carolina was levying a tax of one dollar per ton against all phosphate mined along the river banks. Because of this tax the Coosaw Company, one of the chief exporters of phosphate rock, became involved in 1891 in lengthy litigation and because of this litigation was forced to discontinue operation for over 12 months. Two years later, August 31, 1893, a cyclone which destroyed a large part of the plants and buildings in this area, caused approximately a six-month additional interruption to operations in South Carolina (Mappus, 1935, p. 20). Taking advantage of this grave disability in South Carolina, the Florida phosphate industry gained an important position in the export market during this period.

Three types of phosphate rock have been mined in Tennessee: brown, blue, and white rock. Tennessee deposits came into production in 1894 and gained an important position in the early development of the industry due to their location in the middle of a great agricultural region. Brownrock ores have furnished most of the phosphate mined in Tennessee for more than 50 years. These deposits occur in the western part of the Nashville Basin. The open-pit mining of brown rock has centered principally around Mount Pleasant and Columbia, in Maury County. Most deposits

average less than 6 feet, but sometimes occur 50 feet thick in the deeper depressions. The bluerock deposits require expensive underground methods of mining. The white rock is of too low grade to be commercially profitable.

The commercial development of phosphate rock in Idaho was begun in 1906 and in Wyoming and Utah the following year. The Idaho deposits are sometimes mined by open-cut methods, but usually underground operations are required because of the thick overburden. Utilization of Montana's deposits, which are relatively small in total reserves, has not been great. Beginning in 1921, a gross extraction of some 13.4 millions of long tons by 1950 had been shipped mainly to the Consolidated Mining and Smelting Company, of Canada, Ltd., at its Trail plant in British Columbia. There it is changed into ammonium-phosphate fertilizer.

Such is the occurrence of phosphate rock and its commercial extraction in this country in states other than Florida.

DEVELOPMENT OF THE PHOSPHATE INDUSTRY IN FLORIDA

Four principal types of phosphate have been mined in Florida since production started in 1887. They are: landpebble, riverpebble, hardrock, and soft phosphates. Landpebble and hardrock constitute the two chief sources of Florida's production in recent years.

Landpebble deposits occur in the Bone Valley formations, ranging in colors from white, brown, gray, and green to black. The main landpebble field, which furnishes 95% of Florida's phosphate, is found in Polk, and Hillsborough Counties (see map insert Fig. 1). These deposits are in the west-central part of the state, about 20 miles east of Tampa, extending in a north-south direction for some 65 miles and in an east-west direction for about 45 miles. The pebbles range in size from clay particles to small boulders over a foot in diameter. Other landpebble deposits of lower grade are known to exist in adjoining counties.

The riverpebble phosphate deposits, which occur as bars and banks in stream channels and adjacent lowlands, were formed from any phosphatic material that the stream happened to cross. This type of phosphate was the first to be mined in Florida along the Peace River near Arcadia, DeSoto County, in 1887. It has not

been mined since 1914, due to competition of the landpebble phosphates.

The main hardrock field comprises a belt, about 110 miles long and 5 to 30 miles wide, that extends southward from Suwannee and Columbia Counties to the northern part of Pasco County. Mining has been done in many other counties but at the present time the hard field operations are limited to a small area near Dunnellon, Marion County (Fig. 4).



Figure 4.—Mining of phosphate in hard rock field of Florida. Note 50 feet or more overburden.

Waste ponds in the hardrock district contain considerable quantities of soft phosphate derived from former hardrock deposits. This sediment usually yields 25% or more of P_2O_5 , and is commonly known as collateral phosphate or wastepond phosphate. Very little commercial phosphate is produced in this manner at the present time.

The mining of Florida's phosphates prior to 1890 was similar in methods to those used in South Carolina. These consisted largely in the dredging of rivers and streams. The discovery of hardrock deposits along Florida's west coast created one of the largest mining booms since the Pacific Coast gold rush of 1849. Numerous small towns of that section of the state in the early 1890s had all of the attributes of pioneer gold-mining towns of the Far West,

with much land speculation. Importing of Negro labor from Georgia and Alabama and the use of convict labor were some of the means used to meet labor shortages.

Speculation in phosphate lands was stimulated to a large degree by the foreign capital invested in hardrock as well as in rich pebblerock regions. Britain, Belgium, and France were the chief sources of foreign funds invested in Florida operations. One of the companies with the largest foreign holdings was Phosphate, Ltd., of London, England, which listed its capital and assets at a million dollars as early as 1891. Other foreign operators about 1900 included the following: The French Syndicate, of New High Springs, Florida; French Phosphate Company, of Luraville, Florida; The Societe Universelle de Mines, Industrie, Commerce et Agricole, of Paris, France; and J. Bottenboch and Company, of Brussels, Belgium, which is the only foreign company still operating in Florida at the present time. Most of the above-named foreign holdings were sold to American interests prior to, or immediately following, the first World War. The British acquired phosphate sources in the Pacific and the French turned their attention to the rich deposits in French North Africa. The importance of the British and French production from those deposits in 1950 can be noted in a Producer's Report of The International Superphosphate Manufacturers' Association, London, March 7, 1951. Of the 20,237,689 metric tons of sales and shipments reported (not including an estimated 2 million tons in the U.S.S.R.), the United States supplied 52 per cent, North Africa 32 per cent, and the Pacific islands 10 per cent.

RESERVES OF PHOSPHATE ROCK

Having examined the development of this industry in the United States and particularly in Florida, the main producer, a check on the reserves of this country as well as those abroad is in order.

A reported estimate of the reserves of the United States in phosphate rock indicates a total of nearly 13.5 billion long tons (see Table I). Of this amount 38% is in the state of Florida, 60% in the western states (43% in Idaho alone), and limited reserves in Tennessee and South Carolina. These figures are only estimates, but they do provide some idea of the magnitude of our probable reserves and their distribution among the states.

TABLE I

Production and Reserves of Phosphate Rock in the United States.*
(Data as of 1950)

Operations Started	Market Production (Long Tons) Accumulative Totals	Estimated Reserves (Long Tons)
South Carolina (1867)	13,358,717	11,000,000
Florida (1887)	126,139,371	5,046,409,000
Tennessee (1896)	31,927,819	183,971,000
<i>Western States:</i>		
Idaho (1906)	3,196,786	5,734,187,000
Utah (1907)	20,571	1,702,480,000
Wyoming (1907)	252,062	232,585,000
Montana (1921)	1,764,163	389,946,000
All Other States	207,906	22,863,000
Grand Total United States ---	176,866,395	13,321,239,000

* Data from Minerals Yearbook, U. S. Bureau of Mines, and K. D. Jacobs, U. S. Dept. of Agriculture, Washington, D. C.

A better perspective as to the phosphate industry of this country can, of course, be had through a comparison with estimated known reserves in other parts of the world.

Jacobs of the United States Department of Agriculture estimated the world reserves of phosphate rock and apatite in billions of metric tons as follows: French Morocco, 21,000; United States, 13,535; U.S.S.R., 7,568; Tunisia, 2,000; Algiers, 1,000; Brazil, 572; Islands of the Pacific and Indian Oceans, 182; Egypt, 179; 23 other countries with a total of 670; with a grand total of 46,706. These figures do not include reserves of 16 other countries where known reserves exist because of lack of accurate data. The United States Department of Agriculture estimates that French Morocco alone has reserves about 50% greater than ours, though we do seemingly possess nearly 30% of the world's appraised deposits. It must be recognized, however, that additional deposits of unknown magnitude probably exist. Estimated reserves of 1 to 8 billion metric tons or more are also found in Russia, Tunisia, and Algeria.

FUTURE DEVELOPMENTS

Future production of phosphate rock is difficult to anticipate because it depends on factors of diverse nature including the general

financial conditions that exist from time to time. On the assumption that the supply factor remains constant and the present prosperous conditions continue in this country, the use of phosphate rock will probably increase still more, owing to the heavy demands in the fertilizer and chemical industries, as well as the use for supplementary feeding of livestock. Progress has been made in the latter by extensive research.

Operations in the phosphate mines in Idaho and the Rocky Mountain region probably will be stimulated further to meet the increasing fertilizer demands of the western states, because of the high cost of transportation of phosphate from Florida to that section. Tennessee's total phosphate output will probably continue to remain at about 15% of the domestic supply. Because of the limited reserves and low-grade deposits, South Carolina's operations are not likely to be resumed in the near future.

The rich pebble district of Florida's west coast will probably continue for many years to furnish three-fourths of the total supply of the United States. Major reasons for this large output are: (1) the advantages in economical production because of extensive occurrence of the matrix; (2) access to water transportation for a large part of the domestic and foreign supply; (3) unconsolidated deposits permitting large-scale operations and allowing the utilization of lower-grade ores; (4) production of uranium and rare earth by-products in the future probably will further reduce total operational costs.

Florida, Idaho, and Utah have more than 12 billion tons of estimated phosphate reserves. The present rate of phosphate production in the U. S. is over 10 million tons annually. It is, therefore, encouraging to note that domestic reserves should be ample to supply domestic needs for several hundred years.

LITERATURE CITED

CATHCART, JAMES B.

1950. Distribution of Uranium in the Florida Phosphate Fields. Unpublished report before the American Institute of Mining Engineers, Tampa, Florida, May 6, 1950.

HAZEL, P. E.

1904. *The Century in Phosphate and Fertilizers*. Lucas and Richardson Co., Charleston, S. C.

JACOBS, K. D.

1950. Phosphate Resources and Manufacturing Facilities in the United States. Unpublished paper before the Soil Science Association, College Park, Maryland, August 21, 1950.

JOHNSON, B. L.

1944. Economic Factors of United States Phosphate Industry. *Mining and Metallurgy*, October, p. 76.

JONES, W. R.

1941. *Minerals in Industry*. New York, Penguin.

MAPPUS, HELEN F.

1935. The Phosphate Industry of South Carolina. Unpublished thesis, University of South Carolina, Columbia.

MEHRING, A. L.

1948. Calcium in Fertilizers. *Soil Science*, 65: 12.

ROGERS, G. S.

1914. The Phosphate Deposits of South Carolina. Washington, Government Printing Office.

WRIGHT, CARROLL D.

1896. The Phosphate Industry of the United States. U. S. Department of Labor *Bulletin*, 6th Special Report, Washington, D. C.

Quart. Jour. Fla. Acad. Sci., 17(3), 1954.

A. A. A. S. RESEARCH GRANT

The annual A. A. A. S. Research Grant of \$73.00 has been made available to the Academy for 1954-55. Application may be made for all or part of these funds by the members of the Academy. Please send application to R. A. Edwards, Secretary-Treasurer, Florida Academy of Sciences, Geology Department, University of Florida, Gainesville, Florida, for the committee. Application should be received prior to December 1, 1954, so that the announcement can be made at the Annual Meeting. Request for funds should include the following:

1. Name
2. Address
3. Research Project
4. Special purpose for which research funds are requested.

ADDITIONS TO THE KNOWN FISH FAUNA IN THE
VICINITY OF CEDAR KEY, FLORIDA

DAVID K. CALDWELL
University of Florida

Recent studies by Kilby (1950) and Reid (1954) have presented an essentially complete picture of the ichthyofauna of Cedar Key, Levy County, Florida. However, with the increasing interest in the biology of this Gulf coastal area brought about by the establishment of the University of Florida's Seahorse Key Marine Laboratory, the list of the known fishes of the area should be kept as complete as possible, even though the species included herein are possibly only occasional visitors to Cedar Key.

For some 18 months prior to the writing of this paper, I was engaged in a detailed study of the Pinfish, *Lagodon rhomboides*, in the Cedar Key area. The regular pursuance of this study resulted in the collection and observation of many fishes other than this species. Seven of these incidental species are apparently new to the known fish fauna of the area, an eighth is confirmed, and a ninth previously unreported for some 70 years.

I wish to thank Mr. Ormond Folks, of the R. B. Davis fish house at Cedar Key, for saving the specimens referred to as having been obtained from the commercial fishery.

Unless otherwise indicated, all of the specimens included below are deposited in the University of Florida fish collection. Measurements are expressed as standard length.

ANNOTATED LIST

Carcharinus acronotus (Poey). Black-nosed Shark. A 335 mm. male was collected at Cedar Key by Dr. L. R. C. Agnew of the University of Florida Cancer Research Laboratory on June 1, 1953.

Brevoortia gunteri Hildebrand. Menhaden. An 89 mm. specimen, here tentatively identified as *B. gunteri*, was seined on June 21, 1953, in an enclosed salt marsh pond (fed by high tides) on Way Key.

Anchoa hepsetus hepsetus (Linnaeus). Anchovy. A 105 mm. specimen was taken in a small otter trawl on the edge of the main ship channel near Seahorse Key on April 25, 1953. (Private collection of Dr. E. Lowe Pierce, University of Florida.)

Polynemus octonemus Girard. Eight-fingered Threadfin. A 183 mm. specimen was collected from the commercial fishery on August 10, 1953. This individual had been taken in a gill net from a shallow grassy flat near one of the islands of the area.

Promicrops itaiara (Lichtenstein). Spotted Jewfish. Reid (1954: 74) stated that this species is to be expected at Cedar Key, but that no definite records were available. On June 28, 1953, I identified a 367 pound specimen, approximately 4½ feet in length, taken on hook and line by a sport fisherman from the main pier at Cedar Key.

Xyrichthys psittacus (Linnaeus). Pearly Razorfish. A 132 mm. specimen was obtained on September 1, 1953, from the commercial fishery. The specimen had been taken 15 miles west of the town in about 7 fathoms on a rocky bottom.

Paraclinus fasciatus (Steindachner). Blenny. Two examples, 41 mm. and 37 mm., were trawled on the edge of the main ship channel between Seahorse and Grassy Keys. These were taken on January 24, 1954, and February 7, 1954, respectively. This is probably the "*Paraclinus* sp." noted by Reid (1954: 60), a suggestion already made by him in that paper for his specimens. I wish to thank Mr. Victor Springer of the University of Texas for his positive identification of my specimens.

Porichthys porosissimus (Cuvier & Valenciennes). Midshipman. A 79 mm. example was trawled at night in the main ship channel just off Seahorse Key on November 13, 1953.

Ancylopsetta quadrocellata Gill. Ocellated Fluke. Although this species was recorded by Jordan and Swain (1884: 234), as *Paralichthys ommatus* Jordan & Gilbert, it seems desirable to include it here since it has not been recorded from Cedar Key since that time. These authors note it as "rather common". However, I collected only two specimens, and it was not reported at all by Reid (1954) or Kilby (1950). My specimens were trawled from a deep grassy flat on the west side of North Key on February 7, 1954, and from the main ship channel just outside of Seahorse Key on April 10, 1954. These measured 39 mm. and 91 mm. respectively.

LITERATURE CITED

- JORDAN, DAVID S., and JOSEPH SWAIN
1884. Notes on fishes collected by David S. Jordan at Cedar Keys, Florida.
Proc. U. S. Nat. Mus., 7: 230-234.

KILBY, JOHN D.

1950. The fishes of two Gulf coastal marsh areas of Florida. Mss. (unpub.).
Dissertation presented to the Graduate Council, Univ. of Fla., February, 1950, vii + 179 pp.

REID, GEORGE K., JR.

1954. An ecological study of the Gulf of Mexico fishes, in the vicinity of Cedar Key, Florida. Bull. Mar. Sci. of the Gulf and Carib., 4(1): 1-94.

Quart. Jour. Fla. Acad. Sci., 17(3), 1954.

NOTICE OF ANNUAL MEETING

The 19th meeting of the Florida Academy of Sciences will be held at Florida State University, Tallahassee, December 9, 10, 11. The meeting will begin with a Symposium Thursday night on "Science and Aims of Education". Members are urged to submit papers in the other sessions on the problems of teaching scientists. The deadline for papers is October 22nd, when all papers are due in the hands of the appropriate Chairman.

Word has been received that Dr. H. Horton Sheldon, past President of the Academy, formerly of New York and more recently Dean of the Division of Research and Industry of the University of Miami, has been appointed consultant to the Organization for European Economic Cooperation. His headquarters for the next year will be Paris, France, from which point he will visit a number of European countries.

INSTRUCTIONS FOR AUTHORS

Contributions to the JOURNAL may be in any of the fields of Sciences, by any member of the Academy. Contributions from non-members may be accepted by the Editors when the scope of the paper or the nature of the contents warrants acceptance in their opinion. Acceptance of papers will be determined by the amount and character of new information and the form in which it is presented. Articles must not duplicate, in any substantial way, material that is published elsewhere. Articles of excessive length, and those containing tabular material and/or engravings can be published only with the cooperation of the author. Manuscripts are examined by members of the Editorial Board or other competent critics.

MANUSCRIPT FORM.—(1) Typewrite material, using one side of paper only; (2) double space *all* material and leave liberal margins; (3) use 8½ x 11 inch paper of standard weight; (4) do not submit carbon copies; (5) place tables on separate pages; (6) footnotes should be avoided whenever possible; (7) titles should be short; (8) method of citation and bibliographic style must conform to JOURNAL style—see Volume 16, No. 1 and later issues; (9) a factual summary is recommended for longer papers.

ILLUSTRATIONS.—Photographs should be glossy prints of good contrast. All drawings should be made with India ink; plan linework and lettering for at least ½ reduction. Do not mark on the back of any photographs. Do not use typewritten legends on the face of drawings. Legends for charts, drawings, photographs, etc., should be provided on separate sheets. Articles dealing with physics, chemistry, mathematics and allied fields which contain equations and formulae requiring special treatment should include India ink drawings suitable for insertion in the JOURNAL.

PROOF.—Galley proof should be corrected and returned promptly. The original manuscript should be returned with galley proof. *Changes* in galley proof will be billed to the author. Unless specially requested page proof will not be sent to the author. *Abstracts* and *orders for reprints* should be sent to the editor along with corrected galley proof.

REPRINTS.—Reprints should be ordered when galley proof is returned. An order blank for this purpose accompanies the galley proof. The JOURNAL does not furnish any free reprints to the author. Payment for reprints will be made by the author directly to the printer.

Quarterly Journal

of the

Florida Academy of Sciences

Vol. 17

December, 1954

No. 4

Contents

Auffenberg—Additional Specimens of <i>Gavialosuchus Americanus</i> (Sellards) from a New Locality in Florida	185
Elected Officers for 1955	210
Beck—Studies in Stream Pollution Biology	211
Sherman—The Occurrence of Bison in Florida	228
Telford—A Description of the Larvae of <i>Ambystoma cingulatum bishopi</i> Goin, Including an Extension of the Range	233
Mergen—Anatomical Study of Slash Pine Graft Unions	237
Gildea—Modern Wholesale Market Facilities	246
Pope—The Geoduck Clam in Florida	252
News and Comments	253
Index to Volume 17	254

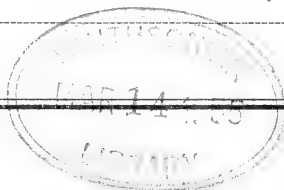

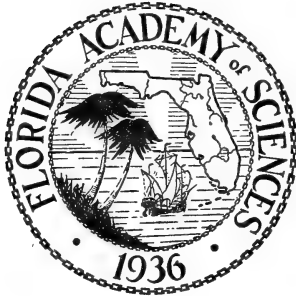

VOL. 17

DECEMBER, 1954

No. 4

QUARTERLY JOURNAL OF
THE FLORIDA ACADEMY OF SCIENCES

A Journal of Scientific Investigation and Research

Published by the Florida Academy of Sciences

Printed by the Pepper Printing Co., Gainesville, Fla.

The business offices of the JOURNAL are centralized at the University of Florida, Gainesville, Florida. Communications for the editor and all manuscripts should be addressed to H. K. Wallace, *Editor*, Department of Biology. All subsequent correspondence concerning manuscripts may be handled directly between authors and *associate editors*: J. C. Dickinson, Jr., Biological Sciences, Department of Biology and Florida State Museum; Donald R. Dyer, *Social Sciences*, Department of Geography; John W. Flowers, *Physical Sciences*, Department of Physics. Business communications should be addressed to R. A. Edwards, *Secretary-Treasurer*, Department of Geology. All exchanges and communications regarding exchanges should be addressed to The Gift and Exchange Section, University of Florida Libraries.

Subscription price, Five Dollars a year

Mailed February 18, 1955

THE QUARTERLY JOURNAL OF THE FLORIDA ACADEMY OF SCIENCES

VOL. 17

DECEMBER, 1954

No. 4

ADDITIONAL SPECIMENS OF *GAVIALOSUCHUS AMERICANUS* (SELLARDS) FROM A NEW LOCALITY IN FLORIDA

WALTER AUFFENBERG

Biology Department, University of Florida

The fossil crocodylian *Gavialosuchus americanus* was first described by Sellards (1915a) on the basis of fragments of a skull and lower jaw from the vicinity of Brewster, Polk County, Florida. Additional fragments of skulls and lower jaws were described by the same author in later papers (1915b and 1916). The first fairly complete skull (AMNH 1651) was figured and described by Mook (1921a), who also used this specimen as a basis for placing *americanus* in the genus *Gavialosuchus*. Lydekker (1886) had previously synonymized *Gavialosuchus* Toule and Kail with *Tomistoma* Müller. In a later paper Mook (1924) described an even more complete skull (AMNH 5663) which verified the generic validity of *Gavialosuchus*.

Although Sellards mentioned a few bones which probably belonged to this species, the postcranial skeleton was still relatively unknown. Therefore, the discovery of a fairly complete specimen in a fairly well articulated state allows an adequate description to be given at the present time, and contributes materially to our knowledge of the osteology of this species. Elements of practically the entire postcranial skeleton as well as a skull and lower jaw, more complete than any previously reported, are available. Portions of at least eight specimens have been found at this locality.

All of the specimens which have been reported in previous papers were collected from a locality near Brewster, Polk County, Florida. The formation from which they were taken is known as the Bone Valley Gravel. The distribution of this formation is not too well known, although it seems to be somewhat restricted to a circular area centering around Hillsborough and Polk counties.

MAR 2 1955

It is entirely possible that it occurs in a considerably greater area, although this has not been fully demonstrated (Cooke, 1945). The discovery of the same species of crocodylian, apparently in the same formation, in western Alachua County, Florida, is thus of considerable geologic interest as well.

The new locality is at the village of Haile, approximately 4 miles northeast of Newberry, Alachua County, Florida (NE $\frac{1}{4}$ Sec. 23, T. 9 S. R. 18E.). The elevation is about 84 feet above sea level (Gunter, *et al.*, 1948). This locality is one quarter mile from another sinkhole containing many Pleistocene fossils (Brodkorb, 1953, 1954, and Tihen, 1952).

STRATIGRAPHY

The fossil remains of crocodylians obtained at this locality were first discovered on the surface, where they were being weathered out of a sinkhole, formed in the Ocala Limestone (restricted). The bed was first exposed when it was practically cut in half by mining operations.

The clay-filled sink is 44 feet deep. The width is 21 feet at the top and 5 feet at the bottom. The general stratigraphy is shown in Figure 1. Since Mr. E. C. Pirkle of the Department of Geology, University of Florida plans to discuss this locality in detail in a future publication, I will give only a brief description of the stratigraphy, as follows:

Bed Number 6. A brownish, cross-bedded clay containing many small broken pieces of bone and limestone. In many instances the bone is polished and water-worn. Isolated shark teeth, cetacean ribs, ray plates and small fish vertebrae are common. Gar scales (*Lepidosteus* sp.), pieces of turtle shells (*Testudo* sp., *Pseudemys* sp., and *Terrepene* cf. *caniliculata*), mammalian teeth (*Equus* sp., *Tanupolama* cf. *mirifica*), and crocodylian teeth and dermal plates (*Alligator* cf. *mississippiensis* and *Gavialosuchus americanus*) are also commonly encountered. This certainly represents a well-mixed fauna, of Eocene, Miocene and/or Pliocene and Pleistocene time. The character of the fossils and the stratigraphy seem to reflect a Pleistocene stream bed that cut through older deposits, thoroughly mixing the faunas from each.

Bed No. 5. A stratum composed of variegated greenish and reddish to yellowish or gray clay. This layer is only found on the northern wall of the sink and may represent a weathering of Bed No. 3. No vertebrate remains have been found in this bed.

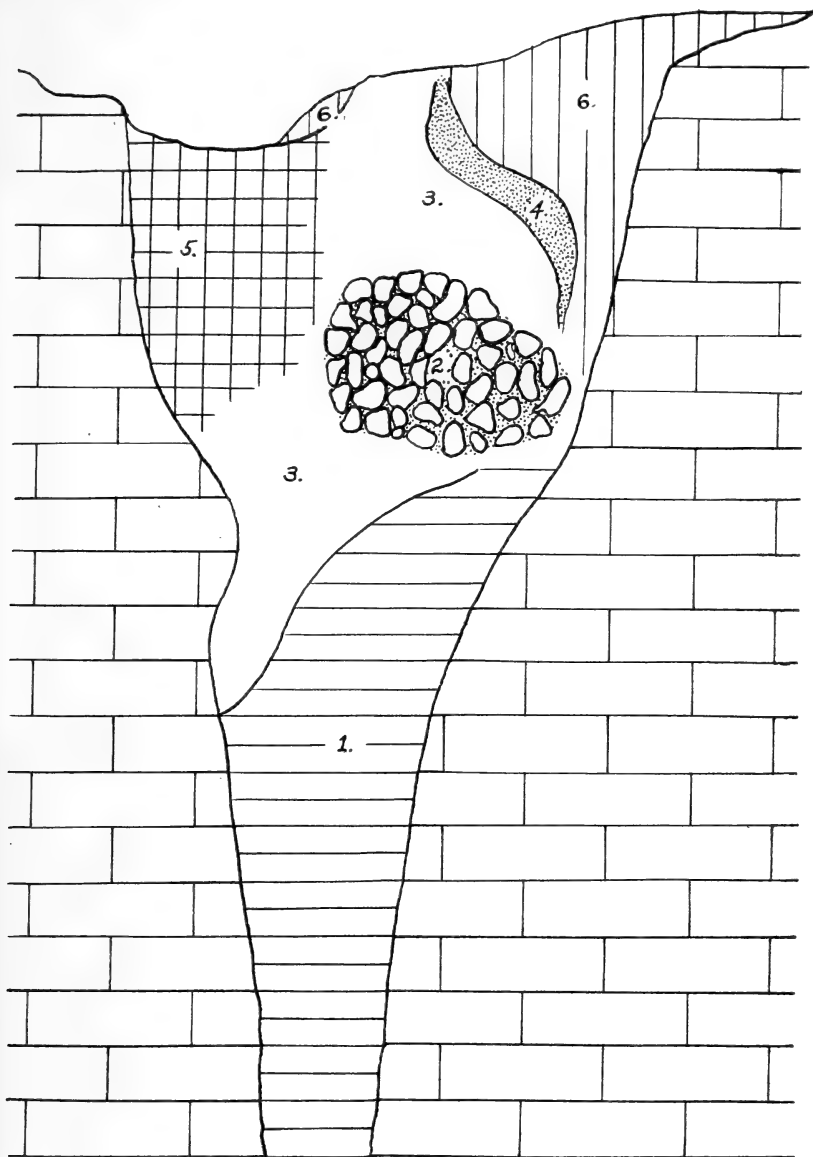

Figure 1.—The general stratigraphy of the Haile, Florida fossil locality from which additional specimens of *Gavialosuchus americanus* are known. Bed No. 6—a brownish crossbedded clay representing a Pleistocene stream bed. Bed No. 5—a variegated greenish to rust-colored or yellowish clay, presumably representing a weathered product of bed number 3. Bed No. 4—bedded phosphatic sands and gravel, grayish to pink in color, and equivalent to the commercially mined portion of the Bone Valley Gravel formation. Bed No. 3—a faintly bedded green to olive-colored clay equivalent to certain facies of the Bone Valley Gravel formation, and containing numerous fossil marine vertebrates, including *Gavialosuchus*. Bed No. 2—a boulder "plug" composed of weathered Ocala Limestone (restricted). Bed No. 1—a pale blue to grayish sandy clay with fine sandy partings and apparently devoid of vertebrate fossils.

Bed No. 4. A bedded stratum composed of grayish to reddish or pinkish sands, containing many phosphatic pebbles which vary in color from gray to purplish or black. Interbedded with these layers are thin beds of grayish, greenish or brownish clays. Thin white or gray, limey or phosphatic layers of secondary origin are also present. Only one tarsal element of a *Gavialosuchus* was found in this layer, and then close to the contact with bed 3. This fossil may have actually been worked out of bed 3.

Bed No. 3. This is a fairly uniform stratum of green to olive-colored clay. There is some evidence of bedding in that there are fine layers of greenish to yellowish sands, or soft limey concretions. This layer contains all of the material assigned to *Gavialosuchus americanus* with the exception of those remains indicated. A shark is represented by practically all of the teeth of the upper and lower jaws, as well as a large number of denticles. Sting rays are represented by poison-conducting caudal spines. The vertebrae of various types of fishes are quite abundant, with many of the elements being articulated. All of these animals suggest a shallow marine environment.

Bed No. 2. This bed is composed of many boulders of Ocala Limestone, with the spaces filled with a pale greenish clay, or white to gray sand. The entire bed is approximately 6 feet thick and 8 feet long. It does not extend across the entire sink, and is located near the center of bed 3. The boulders vary in size from $\frac{1}{2}$ inch to $2\frac{1}{2}$ feet in diameter. Many are somewhat cherty, and their edges are smoothed, apparently as a result of solution.

Bed No. 1. This bed fills all of the lower portions of the sink. It is a pale to dark bluish or greenish clay, with sand partings which are white, gray or yellowish. No vertebrate remains have been found in this bed.

On the basis of lithology, stratigraphy and fauna, the main crocodylian-bearing bed seems to represent a faintly bedded, essentially greenish clay, apparently of marine origin, that is in close proximity to definitely bedded phosphatic pebbles and sands. This description best fits that of the land pebble phosphates, or the Bone Valley Gravel formation (Cooke, 1945, 1939, Cooke and Mossom, 1929, Sellards, 1915a, Matson and Clapp, 1909, *et al.*). This deposit is generally assigned to the Pliocene Epoch. There has been a diversity of opinion as to whether it represents lower or middle Pliocene (= Clarendonian or Hemphillian ages), although the lat-

ter seems most tenable (Lower: Simpson, 1930, Parker and Cooke, 1944, Sellards, 1915a, *et al.*; Middle: Wood, *et al.*, 1941, Stirton, 1936, Cooke, 1945, *et al.*). It has also been regarded as representing late Miocene (Kellogg, 1924) and early Pleistocene (Hay, 1923). The problem requires more study before a definite age can be assigned to the formation.

The Alachua formation, a non-marine deposit frequently considered contemporaneous with the Bone Valley Gravel is found in a long and narrow belt from near the Suwannee River southward to Hernando County. The present locality is near, or within, the area usually indicated as the Alachua Clays (Dall, 1903, 1887, Sellards, 1910, 1914, Simpson, 1930, Cooke, 1939, 1945, Cooke and Mossom, 1929, Parker and Cooke, 1944, Vernon, 1951, *et al.*). Cooke (1945) and Vernon (1951) have correctly indicated that the Alachua formation represents the Miocene, Pliocene and Pleistocene Epochs. However, Simpson (1930) has shown that the fossils in this formation are not thoroughly mixed, but are found as discreet faunas in unmixed portions of many of the sink holes.

Since the two ecologically divergent formations are considered contemporaneous (at least in part) the presence of an outlier of the Bone Valley Gravel formation within, or very close to the area mapped as the Alachua Clays is very interesting. Parker and Cooke (1944), Sellards (1914, 1913), and many other authors have stated that the Pliocene sea did not, or probably did not, cover this portion of the state. Yet, the present locality indicates that it did. Its extent is of course unknown, but its presence is assured (providing the Bone Valley Gravel is Pliocene in age as generally supposed). The marine conditions existent over this portion of the state during the Pliocene Epoch, even for a very short time, may alter many of our concepts concerning the geology of this region. The Pliocene terrestrial species from deposits far beyond the limits of either the Bone Valley Gravel and the Alachua Clay along the St. Johns River Valley also have an important bearing on this problem (personal communication from H. J. Gut). Davis (1946) has pointed out the possibility of Pliocene muck deposits near the St. Johns.

AVAILABLE MATERIAL

The following is an account of the available material from the Haile localities:

UF 6225. This is a fairly complete skeleton in which practically all of the skull and lower jaw, and a large number of the postcranial elements are available. Many of these bones were found in a fairly well articulated state. The size of this individual was probably about 23 feet in length, provided the body proportions are similar to those of modern crocodiles.

UF 6226. One femur from a specimen obviously smaller than UF 6225.

UF 6227. One femur and two fragmental fibulae from a specimen slightly smaller than UF 6226.

UF 6228. One fragmental femur from a specimen slightly smaller than UF 6227.

UF 6229. A portion of the parietal bone and most of the supraoccipital from a rather small specimen (UF 6230?).

UF 6230. A fragmental femur, a complete tibia, fibula and radius are all obviously from the same specimen in view of their close proximity in the deposit and the general agreement in size. One of the two small available left quadrates probably belongs to this specimen. In addition a fairly complete coracoid is also available.

UF 6231. Very fragmental elements which had washed out of the deposit and were found on the surface are given this number. These bones obviously represent a number of individuals. Assignment of these elements to a particular individual is impossible at this time.

UF 6232. The axis and cervical vertebrae numbers 2, 3 and 8 as well as one dorsal vertebra are assigned to this number. It is possible that these remains belong with the portions of the appendicular skeleton indicated as UF 6228 or 6230. From their position in the deposit the latter is most tenable.

UF 6233. One complete fibula.

UF 6234. One fragmental scapula.

UF 6237. A complete basioccipital and fragmental associated skull bones of a small specimen, which along with 6233 and 6234, may represent 6228 or 6230.

UF 6238. A few fragmental vertebrae, pieces of the skull and carpal and tarsal bones belong to a specimen practically identical in size to UF 6225.

Besides these specimens at least two others are represented in the collection. However, these specimens are from different

sink holes and presumably contemporaneous with the deposit under consideration. These are:

UF 6235. A few vertebrae and fragments of a skull were found in a sinkhole approximately 100 feet east of the first locality. The greenish clay is overlain with a reddish to brownish sandy clay which, at present, is not found in the first locality. The greenish clay grades laterally into a brownish clay, presumably the weathered product of the former.

UF 6236. A few vertebrae and dermal plates from a sinkhole 22 feet east of the first locality. The stratigraphy is similar to that described in detail for the first locality.

DESCRIPTION

CAVITIES OF THE SKULL. The various openings of the skull have been described by Mook (1924). The following notes are added to supplement his description.

Supratemporal Fenestrae. In UF 6225 these openings are smaller and more rounded than in AMNH 5663. They are only slightly broader than long, and about the same size as the narial openings, and slightly smaller than the orbit.

Palatal Fenestrae. The shape of these openings has never been fully described. In the present specimen the shape can be fairly well established, since the basioccipital bone somewhat determines the position of the pterygoids, both of which are available. The anterior edge of the pterygoids are provided with an outline of a portion of this opening. Together with the anterior border of the ectopterygoids and the antero-lateral border of the palatines this opening is fairly well defined, at least in general shape (Figure 2).

The shape of the orbits, nasal orifice and the premaxillary foramen seem to be identical with those of AMNH 5663.

Internal Nares. The shape of this opening is the diagnostic character of the genus *Gavialosuchus* (Mook, 1921a, 1924). Although the entire border of this orifice has never been described, the available material led Mook to conclude that its shape is subtriangular, rather than rounded as in most crocodilians. The present specimen corroborates Mook's findings. An important portion of the basioccipital is available, and indicates the approximate position of the available fragmental pterygoid, which forms the anterior border of the opening. In AMNH 1651 the anterior bor-

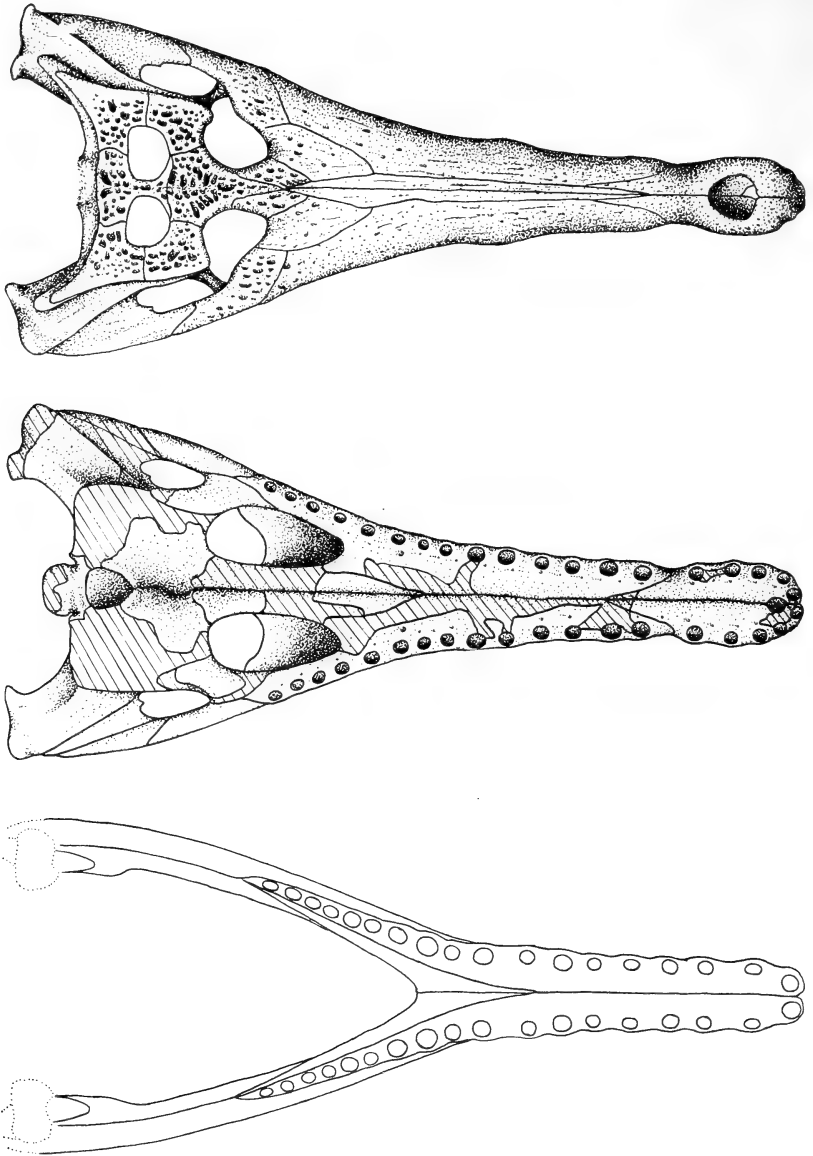

Figure 2.—Dorsal (upper) and palatal (middle) aspects of the skull of *Gavialosuchus americanus* (UF 6225). Considerably more pieces are missing from the palatal surface than the dorsal surface. For this reason the missing elements of the former are indicated by shading. Since all sutural lines, as well as the shape and size of all cranial openings are known for the dorsal surface, the designation of many very small missing chips would only be confusing. An outline drawing of the lower jaw to indicate the shape of the various elements comprising the jaw, as well as the shape and the position of the alveoli of the mandibular teeth is shown in the lower drawing. The articular region of this specimen is rather fragmental and is thus omitted.

der is triangular, the edges being at right angles to one another. Mook (1924) provided a photograph to show the shape of this opening in AMNH 1651. From this figure it appears that the borders of the opening are relatively straight. In UF 6225 they are not straight. The anterior edges of the opening are approximately 90° to one another, as in AMNH 1651, but instead of continuing in this direction, they turn inward, reducing the angle to approximately 60° .

BONES OF THE SKULL. Unless otherwise indicated the bones and their articulations are identical with those of the skulls described by Mook.

Premaxillaries. These bones are the same as in AMNH 5663, except that their palatal contact with the maxillaries extends to the region between the second and third maxillary teeth, as in the type specimen, USNM 8816 (formerly FGS 3697), and in AMNH 1651. However, in AMNH 5663 this contact extends slightly farther than the level of the third maxillary tooth.

Maxillaries. These bones are very similar to those in AMNH 5663, except that in the latter the forward extension of the palatine extends to the level of the eighth maxillary tooth. In UF 6225 it extends to between the seventh and eighth teeth.

The prefrontals and the nasals are alike in both UF 6225 and AMNH 5663, even to a slight inward bend of the right nasal at its contact with the maxillary.

Lacrimals. The shape of these bones are similar in both specimens. However, the contact between the anterior portions of the lacrimals and the nasals, not present in AMNH 5663, are fairly well indicated in UF 6225.

Jugals. The posterior ends of these elements are broken off in AMNH 5663, whereas they are well preserved in UF 6225. In this specimen they extend backward as far as the level of the middle of the supratemporal fenestrae.

The frontal, parietal and squamosal bones are identical with the shape of these elements in AMNH 5663. The postorbitals of UF 6225 are similar to those of AMNH 5663, except that the inferior processes are broken off in the former.

Supraoccipitals. In both UF 6225 and AMNH 5663 these elements cover the posterior surface of the cranium and do not enter into the formation of the cranial table. However, in UF 6229

this bone is quite obvious from above, forming the most posterior portion in a shallow and wide "V"-shaped notch in the parietal. This difference in UF 6229, which is a much smaller specimen than UF 6225 or AMNH 5663, undoubtedly shows a segment of the ontogenetic change in the shape and position of various skull bones in this species.

Palatines. The anterior parts of these bones in both UF 6225 and AMNH 5663 are the same. The middle and posterior portions are absent in AMNH 5663. In UF 6225 the posterior part is present on the left side. The contact of this element with the pterygoid is near the medio-posterior border of the palatal fenestra. Medially this suture moves posteriorly and is well behind the border of the fenestra along the midline.

The ectopterygoids are incomplete, although the fragmental remains seem identical with these elements in AMNH 5663. No part of the basisphenoid is known, although the exoccipitals are represented by a small fragment. The pterygoids are not complete, but identical with the fragmental elements of AMNH 5663, except in the shape of the anterior portion of the internal nares. This difference has been described under "cavities of the skull". A fair portion of the basioccipital is available. It is obvious from this fragment that the element enters into the formation of the condyle. UF 6237, composed of an entire basioccipital and fragmentary associated cranial bones shows that the condyle is composed of this element alone. The lateral and superior edges of the foramen magnum are composed of the two exoccipitals.

MANDIBLE. The lower jaw of UF 6225 is fairly well preserved, and more complete than any other previously reported. It is identical with AMNH 5662 as described by Mook (1921a), except as indicated below.

The second mandibular teeth are widely separated from the third, as in AMNH 5662, but the fourth is farther from the third than in the latter. Sellards (1916) estimates that the total number of mandibular teeth in this species is from 17 to 18. Mook (1921a) states that in AMNH 5662 there are at least 17 teeth. In UF 6225 there are indications of at least 18 teeth. This is probably the correct number for this specimen. Thus, it seems that Sellards estimate, based on fragmental material, is correct.

The symphysis extends to between the eleventh and twelfth teeth, rather than to the twelfth as in AMNH 5662. The splenial

extends forward to the eighth tooth, rather than to between the seventh and eighth teeth, as in the American Museum specimen. In UF 6225 this element extends posteriorly to just behind the level of the last tooth, which is indicated by the position of the last alveolus.

TABLE I

Comparative Measurements of Two Skulls of *Gavialosuchus americanus* in cm.

Measurements	AMNH 5663*	UF 6225
Length of skull, extremities of squamosals to the tip of the snout	90.0	94.0
Length of skull, median line	86.0	88.0
Breadth across extremities of squamosals	22.0	28.0
Breadth of cranial table	21.3	21.5
Length of cranial table	14.0	14.2
Breadth across supratemporal fenestrae	15.5	14.8
Breadth across jugals	33.3(est.)	32.5
Breadth between supratemporal fenestrae	1.5	1.5(est.)
Breadth across orbits	20.5	21.0
Breadth between orbits	5.2	5.0
Length of post. border of skull to ant. and of ant. process of frontal, along median line	24.7	24.1
Total length of nasal	46.2	45.1
Total length of premax., superior surface	29.8	29.0
Median length of premax., superior surface	10.8	19.0
Breadth of snout across narial opening	10.0	10.5
Breadth of snout across notch at premax.-max. suture of lateral surfaces	7.8	8.2
Breadth of snout across first max. teeth	10.5	11.6
Breadth of snout across fifth max. teeth	13.6	15.0
Breadth of snout across ninth max. teeth	17.0	20.0
Breadth of snout across fourteenth max. teeth	25.0	27.0
Length of dental series of max., right side	47.3	50.0
Vertical height of skull, lower ends of ectopterygoids to cranial table	17.2	?
Length of premax. on palate	30.0	28.2
Length of max. along median line of palate	21.5	26.7
Diameter of alveolus of fifth max. tooth	3.2	2.7
Length of quadrato-jugal	?	17.1
Distance from outer edge of articular surface of quadrate to midline of skull	?	21.6
Greatest diameter of articular surface of quadrate (horizontal)	?	9.5
Smallest diameter of articular surface of quadrate (vertical)	?	2.0

* *fide* Mook (1921a).

The external mandibular foramen lies in a horizontal axis, and is fairly oval in shape. Its forward portion extends to the level

of the alveolus of the seventeenth tooth. The anterior portion of the angular is broken off, but on the basis of the sutural surface on the dentary it extends anteriorly to at least the eleventh mandibular tooth. The suture between the surangular and angular begins near the upper posterior radius of the mandibular foramen and curves downward slightly. The inner portions of the mandible are absent, so that the shape of the internal mandibular foramen is unknown. The shape of the articular is not characteristic. Table I gives all of the pertinent measurements of the skull of AMNH 5663 as compared with UF 6225. Table II gives the jaw measurements.

TABLE II

Comparative Measurements of Two Mandibles of *Gavialosuchus americanus* in cm.

Measurements	AMNH 5662*	UF 6225
Length from tip of snout to alveolus of seventeenth tooth	71.3	67.2
Length of symphysis	51.2	47.1
Splenic portion of symphysis	17.5	16.0
Breadth of mandibles at ninth tooth	10.1	12.2
Length of external mandibular foramen	?	12.2
Greatest height of external mandibular foramen	?	5.2
Length from tip of jaw to most ant. border of the external mandibular foramen	?	73.5
Height of mandible at the center of the external mandibular foramen	?	11.2

* *vide* Mook (1921a).

As has been mentioned previously the postcranial skeleton of this species has never been adequately described. Sellards (1915b, 1916) mentions a few elements which he believed represented this species. However, it is not entirely certain that all of the crocodylian remains from the Bone Valley Gravel formation should be assigned to *Gavialosuchus*, since the remains are never found in an articulated condition. The following description of a large portion of the postcranial skeleton of this form follows. The measurements outlined by Mook (1921b) are given as a basis for future comparisons among the Crocodylia.

CERVICAL VERTEBAE. Only two cervical vertebrae of UF 6225 are available. Measurements indicate that they may be the

seventh and eighth elements, comprising the last two before the dorsal series begins.

TABLE III

Measurements of Cervical Vertebrae of UF 6225 (in cm.)

	Length of Centrum	Breadth of Centrum at Ant. End	Height of Centrum at Ant. End	Spread of Prezygop- physes	Spread of Diapophyses	Height, Total	Spread of Postzygop- physes
Cervical 7 ?	7.4	3.8	*	4.6	7.0	*	*
Cervical 8 ?	7.8	5.3	5.5	4.5	7.8	*	*

* Measurements unknown.

The atlas of two specimens are available. Since one element is a surface find it is not at all certain to which individual it belongs. The other element is obviously from UF 6225 due to its position in the deposit. In shape these elements are considerably different than those of *Crocodylus*. This is especially true of the intercentra. When viewed from the front the articular surfaces of the neural arch pedicles and the intercentrum slope downward, rather than being raised and straight across as in *C. americanus*. When viewed from behind, a posterior, rounded, median keel takes part in the articulation with the axis, so that this lower surface is not rounded as in *americanus*, but together with the rib articulations on either side produces a shallow "M"-shaped lower edge. A fragmental axis is also available for UF 6232.

DORSAL VERTEBRAE. Numerous vertebrae are identified as belonging to the dorsal series. Many of these vertebrae are known to belong to UF 6225, but the presence of UF 6238, practically identical in size, plus the fact that some elements were surface finds, leaves much to be desired in assigning these vertebrae to one specimen or another.

LUMBAR VERTEBRAE. Three vertebrae have been identified as lumbar elements. However, it should be noted that Mook (1921b) has shown that posterior dorsal vertebrae are sometimes very difficult to separate from the lumbar series. The fact that the neural spines are quite low, that the diapophyses extend out-

ward a considerable distance, and that the length of the centrum is relatively short are all fair reasons for assigning these vertebrae to the lumbar series.

TABLE IV

Measurements of Dorsal Vertebrae of UF 6225 (Entirely?) in cm.

	Length of Centrum	Breadth of Centrum at Ant. End	Height of Centrum at Ant. End	Spread of Prezygophyses	Spread of Diapophyses	Spread of Parapophyses	Total Height
Dorsal 1	8.0	6.1	5.8	4.3	*	3.6	*
2	8.9	*	5.7	4.1	12.7	4.1	*
3	---	---	---	---	---	---	---
4	8.1	6.2+	5.8	4.3	*	7.6	*
5	8.2	*	6.0	4.3	17.4	9.1	15.9
6	8.9	*	*	*	*	*	*
7	9.2	6.4	5.8	4.6	18.0	10.3	*
8	---	---	---	---	---	---	---
9	9.5	6.6	6.3	4.3	18.4	12.7	*
10	9.5	6.0+	6.3	5.0	*	*	15.2
11	9.8	6.2	6.2	*	*	*	*
12	---	---	---	---	---	---	---
13	9.3	7.4	5.8	5.0	*	*	*

* Measurements unknown.

SACRAL VERTEBRAE. Both sacral vertebrae are known from UF 6225. Another is known from UF 6238. Unfortunately, the ends of the sacral ribs are broken off in all of the available specimens.

TABLE V

Measurements of Lumbar Vertebrae of UF 6225 (in cm.)

	Length of Centrum	Breadth of Centrum at Ant. End	Height of Centrum at Ant. End	Spread of Prezygophyses	Spread of Diapophyses	Height, Total
Lumbar 1	9.0	6.8	5.5	5.0	15.0	15.0
2	9.0	6.8	5.6	5.0	*	*
3	7.8	6.2	*	*	*	*

* Measurements unknown.

TABLE VI

Measurements of Sacral Vertebrae of UF 6225 (in cm.)

	Length of Centrum	Breadth of Centrum at Ant. End	Height of Centrum at Ant. End	Spread of Prezygophyses	Spread of Postzygophyses	Height at Median Line
Sacral 1 -----	7.9	7.5	5.2	5.0	*	*
2 -----	6.0	5.9	4.9	*	3.8	11.5

* Measurements unknown.

CAUDAL VERTEBRAE. Many caudal elements are available, representing bones from more than one specimen. However, the following series is thought to contain only elements of specimen number 6225, since many were found in an articulated state, and in close proximity to other bones of this specimen. Another smaller series from a smaller individual is also available.

TABLE VII

Measurements of the Caudal Vertebrae of UF 6225 (in cm.)

	Length of Centrum	Breadth of Centrum at Ant. end	Height of Centrum at Ant. End	Spread of Postzygophyses	Spread of Prezygophyses	Spread of Transverse Process	Height, Total
Caudal 1	8.7	6.2	5.6	3.2	3.0	11.0	15.6
v - -	9.7	5.3	5.4	*	3.3	*	*
v - -	9.6	5.4	5.0	*	2.9	*	*
v - -	7.8	2.6	2.8	*	0.9	*	*
v - -	7.9	2.4	*	*	0.9	*	*
v - -	7.7	2.9	3.6	*	1.2	*	8.7+
v - -	7.7	3.1	3.2	0.7	*	*	*
v - -	7.5	2.2	3.1	*	0.9	*	*
v - -	7.1	2.5	3.2	0.8	1.1	*	*
v - -	6.7	2.3	2.7	0.4	0.7	*	*
v - -	6.4	1.8	2.0	*	0.6	*	*
v - -	6.3	2.1	2.5	0.4	0.7	*	5.8+
v - -	6.0	1.9	2.3	0.3	0.7	*	*
v - -	5.2	2.0	*	*	*	*	*

* Measurements unknown.

Besides these elements, numerous chevron bones, and ribs, including ventral and cervical elements, were found, but in most

cases they are too fragmental for correct measurement. In some cases it is not certain that they belong to UF 6225. A comparison of these elements with those of *Crocodylus americanus* and *Alligator mississippiensis* indicates no diagnostic characteristics.

DORSAL RIBS. Numerous fragments of dorsal ribs, known to belong to UF 6225 were found. In most instances the exact position of these ribs is unknown. On the basis of the distance between the tubercular and capitular facets certain of these elements may be assigned to definite regions, although the exact vertebrae with which they articulated are unknown. Their fragmentary nature precludes measurement.

PECTORAL GIRDLE AND FORELIMBS

SCAPULA. This element is fairly complete in UF 6225. It agrees quite well with that of *Crocodylus americanus*, as described by Mook (1921b), except that the angle between the blade and the inferior articular surface is smaller. Other fragmental scapulae are available for other individuals.

TABLE VIII

Measurements of the Scapula of UF 6225 (in cm.)

Length, total	24.4
Antero-posterior diameter of the superior border	9.6
Antero-posterior diameter of the inferior border	9.8
Maximum thickness of the distal end	4.8

CORACOID. Portions of the coracoids of two specimens are available. These elements do not appear to differ greatly from those in *Crocodylus americanus*, except that the anterior edge of the blade is not as curved and hook-like as in the latter (Fig. 3). The posterior edge is missing in both elements representing the fossil species, so that its exact shape is unknown.

TABLE IX

Measurements of the Coracoid of UF 6225 (in cm.)

Length, total	16.2
Antero-posterior diameter of the inferior surface	6.9
Maximum thickness of the superior surface	1.0

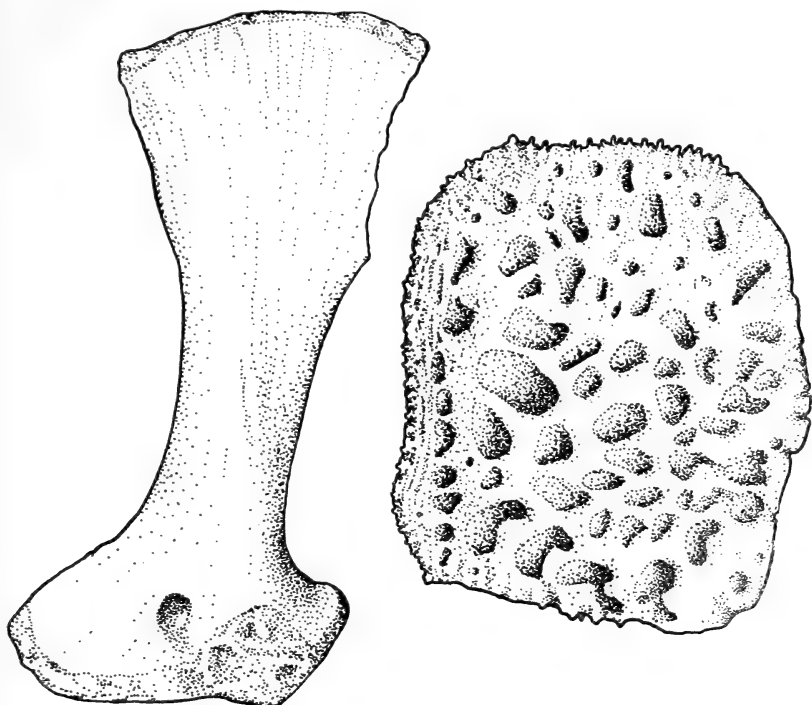

Figure 3.—Left: Coracoid; Right: Dorsal plate of *Gavialosuchus americanus* from Haile, Alachua County, Florida.

HUMERUS. Only one humeral element is mensurable. This bone is questionably from UF 6225. Many other fragmental humeri are also available.

TABLE X

Measurements of Humerus of UF 6225 (in cm.)

Length, total	29.3
Breadth of proximal end	9.3
Breadth of distal end	9.6
Circumference of shaft	12.1
Circumference of shaft	
Total length	.413

RADIUS. Only one complete radial element is known, and this is not from UF 6225, but a smaller individual (UF 6230).

TABLE XI
Measurements of Radius of UF 6230 (in cm.)

Length, total	11.7
Breadth of proximal end	3.1
Breadth of distal end	3.4

CARPUS. Both radiale and ulnare are available. On the basis of their position in the deposit there is reason to believe that they are from UF 6225. However, as they were not found articulated with any other elements known to belong to this individual, exact assignment is impossible.

MANUS. Many elements of the manus were found, but because of their position, great variability in size, and the large number of surface finds, it is impossible to assign them to particular individuals, or to even identify them as to position.

PELVIC GIRDLE AND HIND LIMBS

ILIUM. Only portions of these elements have been found in this deposit. The fact that they are so very fragmentary precludes mensuration.

ISCHIUM. At least two specimens are represented by the ischia from this deposit. Two of these elements, a right and a left, are definitely associated with other remains of UF 6225. The dimensions of only the left element are worthy of tabular representation.

TABLE XII
Measurements of the Ischium of UF 6225 (in cm.)

Maximum length, oblique	24.8
Antero-posterior diameter, proximal end	5.8

PUBIS. Only very small fragments of this bone have been found.

FEMUR. The femora of at least five specimens have been found in this deposit. Comparative measurements of four of the more complete elements are given below. Slight ontogenetic change is indicated in the length/circumference ratios between UF 6225 and 6227.

TABLE XIII

Measurements of the Femora of Four Specimens of *Gavialosuchus* (in cm.)

	6226	6225	6227	6228
Length, total	°	40.5	29.7	°
Breadth, proximal end	4.9	8.5	3.6	3.7
Breadth, distal end	°	9.0	6.3	°
Circumference of shaft	12.6	15.2	10.5	9.0
Distance from fourth trochanter to proximal end	12.7	15.3	10.2	9.6
Distance from fourth trochanter to distal end	°	25.2	19.5	°
Circumference of shaft	°	.375	.353	°
Total length				

° Measurements unknown.

TIBIA. Only one complete tibia of this species has been found in this deposit. This element is probably from UF 6230. Another element with the proximal end broken off may represent UF 6225.

FIBULA. At least three specimens are represented by the fibulae from this deposit. In two of the specimens, both right and left elements are available. A series of ontogenetic changes in the length/circumference ratios are indicated by UF 6230, 6233 and 6225.

TABLE XIV

Measurements of the Tibia of UF 6225 (in cm.)

Length, total	16.8
Maximum diameter at proximal end	8.2
Maximum diameter at distal end	5.4
Circumference of shaft	7.4
Circumference of shaft	
Total length	.434

TARSUS. Various tarsal elements were found, but most of these were surface finds and assignment to certain individuals is untenable. The same applies to the pes.

Certain elements of UF 6225 are missing. Unfortunately many of the remaining bones are not definitely known to belong to this

TABLE XV
Measurements of Three Fibulae of *Gavialosuchus* (in cm.)

	UF 6225	UF 6233	UF 6230
Length, total	25.8	23.0	15.9
Maximum diameter at proximal end	5.2	4.8	3.3
Maximum diameter at distal end	4.7	4.2	2.8
Circumference of shaft	7.2	6.4	3.7
Circumference of shaft			
Total length279	.277	.232

TABLE XVI
Ratios of Limb and Girdle Bones of *Gavialosuchus americanus* *

UF 6225		UF 6230	
Length of scapula	.832	Length of radius	.696
Length of humerus?		Length of tibia	
Length of ischium	1.016	Length of radius	.723
Length of scapula		Length of fibula	
Length of scapula	.602	Length of fibula	.946
Length of femur		Length of tibia	
Length of fibula	1.059	Length of radius	.722
Length of scapula		Length of coracoid	
Length of ischium	.846	Length of coracoid	.904
Length of humerus?		Length of tibia	
Length of humerus?	.723	Length of coracoid	1.017
Length of femur		Length of fibula	
Length of fibula	.841		
Length of humerus?			
Length of fibula	.637		
Length of femur			

* Bones not definitely known to belong to UF 6225 are followed by a question mark.



An exhibit in the Florida State Museum showing the most complete specimen of *Garialostichus americanus* discussed in this report (UP 6225). Reconstruction and assembly by Mr. S. Olsen, Museum Comparative Zoology, Harvard.

specimen. Mook (1921b) has given many ratios of limb and girdle bones, which he considered to be valuable in a comparison of fossil and modern crocodylians. A complete table of these ratios in UF 6225 is impossible because of the missing pieces and the uncertain assignment of some remains to this individual. However, of such elements that are known to represent this specimen their ratios have been calculated. Various ratios for UF 6230 are available and these are also given.

DERMAL PLATES. Sellards (1916) very briefly described a dermal plate presumably of this species, from Brewster, Florida. No other writer has mentioned this armor. Approximately 50 plates have been recovered from the Haile deposit. Since these elements are rather characteristic and are easily told from the genus *Alligator*, which is also known as a fossil from various deposits throughout the state, a description of these bones is of some value.

From above the shape is quite variable, ranging from practically circular to rectangular. The plates of the median series are usually rather square, but always with one obviously rounded corner. The two edges opposite this radius are generally beveled, so that it appears as though the plates were overlapping in life. They are not provided with the median keel found on the dorsal plates of most crocodylians. The upper surface is deeply pitted, each pit being somewhat rounded, and not arranged in any definite order (see figure 3). Since these elements vary considerably in size and shape in various regions of the body, measurements of the entire series seems unjustified, as their exact position in life is unknown. However, most of the elements from UF 6225 are approximately 9 cm. long, 8 cm. wide and 2 cm. thick. The largest plate is 10.1 cm. long, 9.3 cm. wide and 2.5 cm. thick.

DISCUSSION

Mook (1924) has shown that *Gavialosuchus americanus* is closest to *Gavialosuchus eggenburgense* Toulou and Kail and *Tomistoma calaritanus* Capellini. The former is known from the Miocene of Austria while the latter is from the Italian Tertiary. *Gavialosuchus* is readily separated from *Tomistoma* on the basis of the shape of the internal nares, which are subtriangular in the former and rounded in the latter.

Gavialosuchus eggenburgense is told from *americanus* on the basis of the characters enumerated below. Many of the thirty characters of *americanus* listed by Mook in a comparison of a number of species are now shown to be more variable than he supposed with the availability of the recently discovered skull. Thus, the main difference between *eggenburgense* and *americanus* are: (1) 14 maxillary teeth in *americanus*, 15 in *eggenburgense* (will probably be found to vary as more specimens are uncovered of both species); (2) 5th maxillary tooth much larger than the 4th in *americanus*, equal in *eggenburgense*; (3) expansion of skull at 5th maxillary teeth in *americanus* and at 8th in *eggenburgense*; (4) maxillo-palatine suture extends forward to 8th maxillary tooth in *americanus*, and to the 9th in *eggenburgense*.

It is obvious that these two species are very close, though apparently distinct on the basis of the available specimens.

The locality discussed in the present paper indicates that this species inhabited shallow inshore marine waters as well as estuaries. There is reason to believe that *americanus* inhabited an ecological situation which was undoubtedly widespread during the past as well as the present. Its range may well have embraced the major portion of the Gulf Coast as well as a possible extension up the Atlantic Coast in appropriate sheltered bays and estuaries. Its presence is easily determined in Tertiary marine deposits in eastern United States on the basis of the un-keeled dorsal plates with which it is provided. Examination of these elements from ecologically equivalent deposits in appropriate localities may shed much light on the former distribution of this interesting crocodylian.

ABBREVIATIONS

Throughout the course of this paper the following abbreviations have been used: FGS—Florida Geological Survey; USNM—United States National Museum; AMNH—American Museum of Natural History; UF—University of Florida.

ACKNOWLEDGMENTS

I wish to take this opportunity to thank the many individuals who have been so very helpful in many diverse ways throughout the course of this problem. In particular I wish to thank Doctors A. B. Grobman, P. Brodkorb, J. C. Dickinson, R. Bader and R. A.

Edwards, as well as Messrs. E. C. Pirkle, J. W. Crenshaw, R. Highton and R. M. Johnson, all of the University of Florida. I also wish to thank Messrs. R. O. Vernon and H. Winters of the Florida Geological Survey for helpful criticism, and for the loan of specimens. To Mr. J. Gut of Sanford, Florida, I wish to show appreciation for the identification of some mammalian remains.

LITERATURE CITED

BRODKORB, P.

1953. Pleistocene birds from Haile, Florida. *Wilson Bull.*, 65(1): 49-50.
 1954. Another new rail from the Pleistocene of Florida. *Condor*, 56(2): 103-4.

COOKE, W. C.

1939. Scenery of Florida. *Bull. Fla. Geol. Surv.*, (17): 1-118.
 1945. Geology of Florida. *Bull. Fla. Geol. Surv.*, (29): 1-393.

COOKE, W. C., and S. MOSSOM

1929. Geology of Florida. *Ann. Rept. Fla. Geol. Surv.*, (20): 29-228.

DALL, W. H.

1887. Notes on the geology of Florida. *Amer. Jour. Sci.*, (34): 161-170.
 1903. Tertiary fauna of Florida. *Wagner Free Inst., Sci. Trans.*, 3(6): 15-54.

DAVIS, J. H., JR.

1946. The peat deposits of Florida. *Bull. Fla. Geol. Surv.*, (30): 1-247.

HAY, O. P.

1923. The Pleistocene of North America and its vertebrated animals from the states east of the Mississippi River and from the Canadian Provinces east of Longitude 95°. *Carnegie Inst. Wash. Publ.*, 322: 1-405.

GUNTER, H., ET AL.

1948. Elevations in Florida. *Bull. Fla. Geol. Surv.*, (32): 1-1158.

KELLOGG, A. R.

1924. Pelagic mammals of eastern North America. *Bull. Geol. Soc. Amer.*, 35(4): 755-766.

LYDEKKER, R.

1886. On the occurrence of the crocodilian genus *Tomistoma* in the Miocene of the Maltese Islands. *Quart. Journ. Geol. Soc. London*, 42: 20-22.

MATSON, G. C., and F. G. CLAPP

1909. A preliminary report on the geology of Florida. *Ann. Rept. Fla. Geol. Surv.*, (2): 50-67.

MOOK, C. C.

- 1921a. Skull characters and affinities of the extinct Florida gaviel, *Gavialosuchus americanus* (Sellards). *Bull. Amer. Mus. Nat. Hist.*, 44: 39-46.

- 1921b. Notes on the postcranial skeleton in the Crocodylia. *Bull. Amer. Mus. Nat. Hist.*, 44: 67-100.
1924. Further notes on the skull characters of *Gavialosuchus americanus* (Sellards). *Amer. Mus. Nat. Hist. Nov.*, (155): 1-2.
- PARKER, G. G., and C. W. COOKE
1944. Late cenozoic geology of southern Florida, with a discussion of the ground water. *Bull. Fla. Geol. Surv.*, (27): 1-119.
- SELLARDS, E. H.
1910. A preliminary paper on the Florida phosphate deposits. *Ann. Rept. Fla. Geol. Surv.*, (3): 21-41.
1913. Origin of the hard rock phosphates of Florida. *Ann. Rept. Fla. Geol. Surv.*, (5): 23-80.
1914. The relation between the Dunnellon formation and the Alachua Clays of Florida. *Ann. Rept. Fla. Geol. Surv.*, (6): 161-2.
- 1915a. The pebble phosphates of Florida. *Ann. Rept. Fla. Geol. Surv.*, (7): 25-116.
- 1915b. A new gavial from the late Tertiary of Florida. *Amer. Journ. Sci.*, pp. 135-8.
1916. A new tortoise and a supplementary note on the gavial, *Tomistoma americana*. *Amer. Journ. Sci.*, pp. 235-40.
- SIMPSON, G. G.
1930. Tertiary land mammals of Florida. *Bull. Amer. Mus. Nat. Hist.*, 59: 149-211.
- STIRTON, R. A.
1936. Succession of North American continental Pliocene mammalian faunas. *Amer. Journ. Sci.*, 32: 161-206.
- TIHEN, J.
1951. *Rana grylio* from the Pleistocene of Florida. *Herp.*, 8(3): 107.
- VERNON, R. O.
1951. Geology of Citrus and Levy Counties, Florida. *Bull. Fla. Geol. Surv.*, (33): 1-186.
- WOOD, H. E., *ET AL.*
1941. Nomenclature and correlation of the North American continental tertiary. *Bull. Geol. Soc. Amer.*, (52): 1-48.

FLORIDA ACADEMY OF SCIENCES

ELECTED OFFICERS FOR 1955

- President.....J. C. Moore (Biology)
Everglades National Park, Homestead
- President-Elect.....H. K. Wallace (Biology)
University of Florida, Gainesville
- Secretary-Treasurer.....R. A. Edwards (Geology)
University of Florida, Gainesville
- Chairman, Biological Sciences Section.....Ralph Yerger (Zoology)
Florida State University, Tallahassee
- Chairman, Physical Sciences Section.....Harry Robertson (Physics)
University of Miami, Coral Gables
- Chairman, Social Sciences Section.....Burke Vanderhill (Geography)
Florida State University, Tallahassee
- Council Member at Large.....Grace Madsen (Botany)
Florida State University, Tallahassee
- Council Member at Large.....J. P. Lesperance (Physical Sciences)
University of Miami, Coral Gables

STUDIES IN STREAM POLLUTION BIOLOGY

I. A SIMPLIFIED ECOLOGICAL CLASSIFICATION OF ORGANISMS

WILLIAM M. BECK, JR.
Florida State Board of Health

INTRODUCTION

In recent years stream pollution investigations have been receiving increasing attention. With modern industrial expansion and increasing urbanization nationally, the need for greater conservation of our aquatic resources has become more obvious, due to shortages of water in some areas and destruction of the value of other streams by increasing pollutional loads. This need is being met with varying degrees of success by our federal and state agencies, and by an increasing awareness of their own responsibilities by public officials and by industry. In spite of greater activity with regard to the chemical and physical aspects of pollution investigation, biological data do not at the present time constitute a standard part of this work in many parts of the country. The reasons for this neglect of biotic data are not too hard to find.

Most stream pollution investigations are carried out or directed by engineers. While many of these engineers desire, or at least approve of, the use of biotic data, the ideas that such biological investigations are exceedingly complicated and prohibitively expensive are widespread. A brief review of the history of biological measurement of pollution will show why these ideas exist.

The works of Kolkwitz and Marsson (1908-1909) were pioneering studies in the use of aquatic organisms as indicators of the ecological conditions under which they exist. Organisms were classified as oligosaprobic, mesosaprobic and polysaprobic, depending on the concentration of decomposable organic matter in the streams under consideration.

Richardson (1921, 1925, 1925a, 1928) studied the organisms of the polluted Illinois River where he developed a classification of the bottom organisms using seven groups of species. These are as follows:

- I. The pollutional group, which includes the Tubificidae and at least two species of midge larvae.

- II. The sub-pollutional group, unusually tolerant subdivision. Included here are several each of the Sphaeriidae, leeches, midge larvae and Bryozoa.
- III. The sub-pollutional group, unusually tolerant or doubtful subdivision. This category was set up for several doubtful species of midge larvae.
- IV. The sub-pollutional group, less tolerant subdivision. This group included several species of midge larvae, Sphaeriidae, one gastropod, one leech, a few worms and a few young Unionidae.
- V. Pulmonate snails and air-breathing insects.
- VI. Current-loving species other than pulmonate snails and air-breathing insects.
- VII. Cleaner-water species.

Major contributions to an understanding of the biotic effects of pollution were made by Lackey and summarized in his own report published in 1941.

The paper by Gaufin and Tarzwell published in 1952 is an excellent study of the utilization of aquatic invertebrates in stream pollution investigations. They employ both indicator species and indicator associations. Conclusion 5 (p. 64) states: "Pollutional associations are characterized by few species but large numbers of individuals." This is a fundamental concept in any classification of organisms with regard to decomposable organic pollutants in which a toxic effect is negligible.

Patrick (1949) bases her evaluation of stream conditions only on diversity of fauna and flora. Her study was the result of the work of Dr. Patrick, some twenty members of her staff, and twenty consultants. The total amount of information gathered by this group is great, but hardly within economic reach of the average state regulatory agency or industry, and the information obtained is not available to the general research worker.

Certain fundamental differences between the Gaufin and Tarzwell approach and that of Patrick are brought out in a recent article by Patrick (1953) and its accompanying discussion by Gaufin and Tarzwell. The most important differences are in the extent of survey work performed in the programs of these two groups of investigators. Patrick's methods suggest that the bio-dynamic cycle

should be maintained in the primitive condition, while Gaufin and Tarzwell believe that this cycle may be altered to a major degree without destroying the value of a stream. Thus the methods of Gaufin and Tarzwell allow for equitable stream use, while any deviation from the primitive bio-dynamic cycle is interpreted by Patrick as evidence of pollution.

I had occasion to discuss the Gaufin and Tarzwell program with them while attending a training course at the research and training center at which they did their work, and I have made two surveys with Dr. Patrick and her staff. Both programs are consequently well known to me and are respected.

In the paragraphs above, some five programs for the biotic examination of streams have been outlined. Of these programs only one, that of Lackey, appears to be relatively simple and economical. Kolkwitz and Marsson attempted to classify all aquatic organisms with regard to degrees of pollution, a project that must have required the full-time service of an impressive array of biologists. The reports by Richardson cover work done by most of the staff of the Illinois State Natural History Survey, again a program that is too costly for most regulatory agencies. The Gaufin and Tarzwell program is simpler, but still one that uses four or five biologists. Patrick's surveying methods have received the most publicity and are consequently better known among state regulatory agencies than are the others. In this case the best known program is the most complex and costly one. The need for a simplified, economical program for the biological evaluation of stream condition is, therefore, a real one.

A number of writers have published shorter works with many valuable ideas and suggestions. Bartsch (1948) and Van Horn (1949) presented general ideas on the biotic response to various types and degrees of pollution. The paper published by Henderson in 1949 demonstrates the amount of biological information that might be gathered by one man using the Surber sampler.

The above and many other papers constitute a fairly extensive literature on the subject of stream pollution biology. A review of this literature indicated that a simple, yet adequate, program could be developed.

The present study began early in 1948 with chemical, biochemical and physical investigations of stream conditions in Florida. Biological work started in August, 1950, and has continued to the

present. Thus two and one-half years were devoted to obtaining a general understanding of the chemical and physical aspects of pollution and stream behavior before any attempt was made to examine the biological conditions extant in Florida streams.

Setting up a biological program was accompanied by certain problems in the selection of methods and organisms. The methods selected should, of course, be effective, they should be economical, and they should not be too time-consuming.

The first consideration became the choice of method. As outlined above, there have been two main directions of investigation into the biology of stream pollution—the study of indicator organisms or a study of the diversity of fauna. It was felt that both viewpoints could be examined simultaneously, thus avoiding two separate lengthy studies. My employment by a state stream regulatory agency proved a major asset in that at least some information regarding the condition of every stream within the state was either in our files or could be obtained quickly. In the case of interstate streams such information could generally be obtained in a few days.

The selection of organisms required more careful consideration. Three groups of animals have been used in the past; the fishes, the plankton, and the macroscopic invertebrates (frequently referred to as “bottom organisms”). The fishes presented several problems which made them undesirable for this work. Their superior swimming ability enables them to cover significant distances in a brief period and possibly enables them to withdraw entirely from a polluted area; it is difficult for one man to collect a fair representation of the species present quickly; and storage of specimens rapidly becomes a problem.

Total plankton, or various elements comprising it, have been widely used in the past. My initial objection was that these organisms had received comparatively little attention in Florida and were virtually unknown. In addition, they are, by definition, at the mercy of currents and are, in essence, a moving fauna.

The macroscopic invertebrates were finally selected as biological indicators of ecological conditions for a number of reasons. As a group they are relatively well known in Florida. Faunal studies have been made of the Ephemeroptera, Odonata, aquatic Coleoptera, Trichoptera, Culicidae, aquatic Hemiptera, Tipulidae, crayfishes and sponges. Contributions have been made toward a knowledge of the molluscs, Plecoptera and Ceratopogonidae. Many

of these organisms live in cases attached to immovable objects, burrow in the bottom of the stream or are vegetation dwellers. The aquatic life-histories are long enough in most cases to make the development of a fauna in a section of a stream a lengthy process. Ecological studies made of the aquatic invertebrates in Florida strongly indicate that definite response to environmental alterations, i.e., organic pollution in the present study, might be predicted. In addition, the number of species in some of these groups is not great.

It is probable that an adequate definition of pollution has not been written. The following, inadequate though it may be, is used in this report. Pollution is the alteration of any body of water, by man, to such a degree that said body of water loses any of its value as a natural resource. This definition stems in part from the old English common law and the concept of riparian rights. It differs from most other definitions in the natural resource viewpoint. Water is unquestionably one of our truly important natural resources. If we may extend this last viewpoint somewhat and consider a stream as a resource, then a common sense approach to the subject of stream pollution abatement and equitable stream use is not difficult to reach.

ECOLOGICAL CLASSIFICATION

There appears to be no simple classification of the streams of Florida. There are, however, definite categories of streams that exist as distinct types. Ecological distribution of the organisms discussed in this report will be considered in terms of these stream types.

The classification proposed by Rogers (1933) and modified by Herring (1951) has been followed. Herring recognized the following stream types in his study: calcareous, sand-bottomed, swamp-and-bog, and the larger rivers of mixed origin. In a sense this classification is simplified to an extreme degree. Actually there are all degrees of intergradation between any two of the above types.

Calcareous streams originate entirely, or to a major degree, from calcareous springs. These streams are of major importance in Florida which has seventeen springs of first magnitude (average flow of 100 second-feet or more), according to Ferguson *et al* (1947).

In addition, Florida has forty-nine springs of second magnitude (average flow 10 to 100 second-feet). The normal pH range for calcareous streams is 7.0 to 8.2, the alkalinity is generally high and is in the form of bicarbonate. The water is usually clear; the bottom composed of limestone, sand or clay, and plant growth may be slight to heavy. The calcareous stream is widely distributed in the state.

Sand-bottomed streams are fed by lakes, swamps or ground water from seepage areas. These streams are acid (pH 4.5 to 6.5), the water is soft and color is high. Bottom materials consist of sand, occasionally limestone, fine gravel and plant detritus in the quiet pools. Plant growth may be slight to heavy.

The swamp-and-bog streams are characteristically found in the Coastal Lowlands and are very similar in origin and chemistry to the sand-bottomed stream, the most significant difference being the higher velocity normally found in the latter stream type. In the case of the swamp-and-bog stream, flow is frequently imperceptible and the bottom may be of mud or very fine organic detritus. Organisms such as simuliid larvae, stonefly nymphs, or helgramites, generally found in streams of at least moderate velocity, are seldom found in these swamp streams. The invertebrate fauna of this type of stream is more suggestive of a pond or swamp than of a stream. The pH of such a stream may range as low as 4.0.

The larger rivers of Florida are streams of diverse origin and behavior. Since this report does not encompass a study of stream types and origins, only one of these rivers will be discussed here. As an example of a larger stream, the Suwannee River originates in the great Okefenokee Swamp of southern Georgia. Near the Georgia-Florida line, this river has the characteristics of a swamp-and-bog stream with dark, sluggish, acid (pH 4.2) water. A few miles downstream, however, the gradient increases, the stream bed is composed of Ocala limestone and sand, the pH increases to over 5.0, and the river has become essentially a sand-bottomed stream. Downstream from this section of the river the first of a large number of calcareous springs discharges into the stream. The combined effects of the addition of spring water and the solution of limestone in the bed of the river convert the Suwannee into a calcareous stream within comparatively few miles. Thus all three stream types discussed above may be found in the same stream within a few miles of its length and the main stream has to be

classified as yet a fourth type because of its complex origin and unusual behavior. In the Suwannee, variation in discharge is accompanied by most significant variations in water chemistry.

The above discussion points out but a few of the problems involved in classification of the streams of Florida. In the Coastal lowlands and the Central Highlands the acid characteristics of the sand-bottomed stream appear to be derived from organic sources (humic acid, humates, etc.), while in the Western Highlands there are streams (within the defined limits of the sand-bottomed stream) in which the acidity appears to be from an inorganic source. All this merely means that a great deal more work needs to be done in the field of fundamental limnology in Florida.

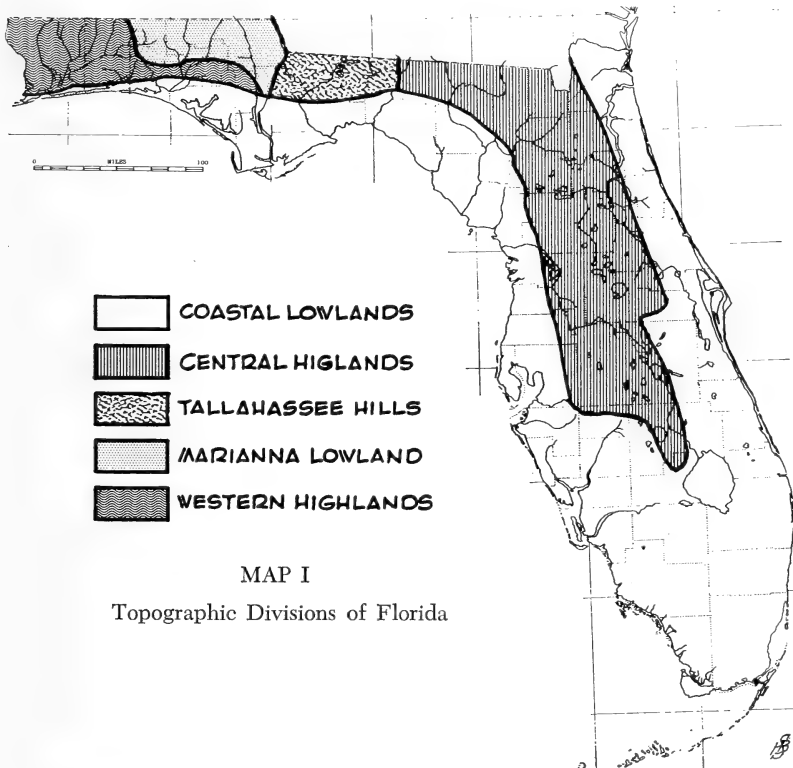

Geographic distribution of organisms is reported by topographic divisions described by Cooke (1939). Cooke (p. 14) writes: "The

part of the Floridian Plateau that lies above sea level—the State of Florida—is divisible into five natural topographic regions: the Coastal Lowlands, or more recently emerged region, which almost everywhere lies less than 100 feet above sea level; and the interior, generally higher, hilly regions, consisting of the Western Highlands, the Marianna Lowlands, the Tallahassee Hills, and the Central Highlands.” The generalized outlines of these regions are shown on map I. The tabulation of distribution of organisms in these regions showed such complete distribution that the table seemed pointless and was consequently omitted.

Most of the organisms reported on in this paper are present in the streams throughout the greater part of the year and collections made during the winter months are fully as significant as are summer collections.

METHODS

The actual mechanics in the establishment of the program involved sampling streams of known pollutional condition. This included streams which received no domestic or industrial wastes, as well as streams exhibiting varying degrees of pollution. It was decided that a given organism must be present in a minimum of twenty collections before any attempt would be made to examine the records with regard to the proposed classification. This was an arbitrary figure which appeared to me to be high enough to represent a significant ecological and geographical distribution and small enough to permit a reasonably lengthy list of organisms to be obtained in a short time. It should be noted that these collections were not made in any definite sequence. In other words, the organisms were not collected from clean streams alone, but streams in all conditions with regard to organic pollution, as well as various rates of flow, were sampled as they were encountered. Such collections were made while I was conducting chemical or bacteriological surveys, with an occasional short period devoted to biological work alone. These collections were obtained for a period of a year before any attempt was made to develop a classification. By that time, approximately two hundred collections had been made. The present paper, with but minor revisions in the initial classification, is based on the study of five hundred collections and an estimated fifty thousand organisms.

General stream collecting methods are used in securing the biological samples. I normally use a dip net, Eckman dredge, coffee strainer, potato fork and a series of shallow, white-enamelled pans. Care must be taken that the various habitats within the area selected are examined and a representative collection obtained. It is more difficult to obtain a reliable collection from a polluted area than from a clean one because the collector must be certain that the more sensitive forms were actually lacking and not merely overlooked due to haste. This is particularly obvious when one considers that the methods here presented are directed toward proving that an area is clean and that inability to do so constitutes evidence of pollution.

An actual survey using these methods begins with the selection of stations with regard to the actual or eventual introduction of waste materials into the stream. Such stations should also be typical of the stream in general and should be readily accessible.

Following careful and representative collecting at all stations in the survey, the material is separated and identified as accurately as possible by the collector. Classification with regard to organic pollution follows next. Certain organisms, tentatively identified by me, are then forwarded to specialists in the various groups represented for final identification.

Essentially all the material collected in these surveys is saved and eventually is sent to private collectors or to museums.

INDICATOR ORGANISMS

As indicator organism is a plant or animal, the presence or absence of which is indicative of some fact or facts with respect to its environment. When the environment is altered by organic pollution both the fact of pollution and the degree of pollution logically should be demonstrable by the use of indicator organisms which have been properly selected.

In the classification of organisms, I decided against the use of a terminology derived from Latin or Greek (as in the Kolkwitz and Marsson system). Such a terminology must be carefully defined and would be most difficult to interpret in view of the complexity of pollution. In addition, most of my reports are submitted to engineering personnel who consider such terminology so much double-talk.

In this study I have divided the aquatic invertebrates into five numbered classes, of which only the first three are important in the reporting of stream conditions. The remaining two classes are categories of convenience, as will be pointed out below.

Class I is comprised of those organisms which have been found to tolerate no appreciable organic pollution, the more sensitive forms. The presence of Class I organisms is considered indicative of the fact that the water in which they are found is clean.

Class II organisms are those which tolerate a moderate amount of pollution, but do not tolerate conditions approaching or reaching the anaerobic. Thus the presence of Class II organisms may be interpreted to mean that the area in question is not heavily polluted.

Class III contains organisms which have been found in heavily polluted areas. It should be understood that no organism in Class III may be considered indicative of pollution. These organisms may be found in clean waters, moderately polluted waters, or grossly polluted waters.

Class IV includes organisms independent of dissolved oxygen—the air breathing forms. In this category are the Hemiptera, most larval and adult Coleoptera, Culicidae, Syrphidae, Tipulidae and pulmonate snails. Since the first effect of an organic waste on a body of water is a reduction in dissolved oxygen content, it seemed that these independent organisms might be placed in a separate category and the time saved could more profitably be devoted to organisms that were closely attached to the aquatic habitat. This does not mean that all the organisms in this classification would of necessity respond similarly to environmental alteration due to organic pollution. Molluscs of the genera *Physa* and *Ferrissia* are listed under Class III due to their frequent occurrence in collections and their demonstrated ability to survive high degrees of pollution.

Class V comprises those organisms which have not been otherwise classified due to such factors as too few records, lack of knowledge of their physiological requirements, or organisms for which identifications are pending. This class is in essence the reservoir from which future representatives of the first three classes will be derived.

Table I lists the number of records for each of the organisms comprising classes I, II, and III with reference to the three degrees of pollution recognized in this study. Examination of this table naturally raises the question as to the level of identification at

which significant indicator value is found. Certainly specific determinations are the most desirable. Florida, however, is still a pioneer area with regard to the taxonomy of many of the groups of organisms which I collect. The genus *Asellus* is an interesting example of the taxonomic problems involved. All specimens of this genus (with the exception of damaged specimens) thus far sent to Dr. Mackin have been determined to species, but there are three species for which only manuscript names are available. In the case of the stoneflies, reporting in this paper is done at the level of order, although all specimens are identified to species. Dr. Gaufin and I have been working on the nymphs of this order for the past eighteen months and the study is quite incomplete. The widely distributed mayfly genus *Stenonema* was used as an indicator organism at generic level before enough records were available to make specific identifications significant. The genus then yielded three Class I species (*exiguum*, *smithae* and *Stenonema* spp., this last including *proximum* and an unknown species). In the case of the damselfly *Argia*, seventy-two records were available before the nymph was even classified.

When at least twenty records for a Class V organism are present each record is examined carefully. If the organism has been found only in clean waters, it is placed in Class I. If, however, a single record is from a moderately polluted area the organism falls in Class II, just as a single record from a heavily polluted area places the organism in Class III.

During a recent discussion of this classification, it was suggested that if a single record may bring about the transfer of a species from a cleaner to a less clean class, eventually all organisms would become Class III. While the suggestion appears quite logical, there has been little in practice to indicate that such is the case. During the nearly three years that this classification has been in use, only two Class I organisms have been lowered to Class II and none from either I or II to III.

It is probable that eventually a statistical scale for the classification of these organisms may be called for. A suggestion of the usefulness of such a scale may be found in Table I. Of a total of seventy records for *Palaemonetes paludosus*, four are from moderately polluted areas, while of sixty-eight records for *Oecetis* spp. only one is from a moderately polluted area. It would thus appear that *Palaemonetes* would more probably be found in an

area of moderate pollution than would *Oecetis*, and that the former is a more reliable member of Class II than is the latter. A statistical scale may be suggested as a future refinement, but does not enter into the present interpretation of results.

TABLE I
Pollutional Distribution

Organism	Clean Water	Moderately Polluted Water	Highly Polluted Water	Total Number Records	Class
<i>Oligochaeta</i>	191	10	9	210	III
<i>Asellus</i> spp.	85	0	0	85	I
<i>Hyalella azteca</i>	87	6	0	93	II
<i>Palaemonetes paludosus</i> ..	66	4	0	70	II
Hydracarina	73	0	0	73	I
Plecoptera	61	0	0	61	I
<i>Stenonema exiguum</i>	58	0	0	58	I
<i>Stenonema smithae</i>	62	0	0	62	I
<i>Stenonema</i> spp.	46	0	0	46	I
<i>Gomphus pallidus</i>	48	3	0	51	II
<i>Gomphus</i> spp.	27	1	0	28	II
<i>Progomphus</i> spp.	40	0	0	40	I
<i>Macromia</i> spp.	39	3	0	42	II
<i>Argia</i> spp.	72	0	0	72	I
<i>Corydalis cornutus</i>	87	0	0	87	I
<i>Oxyethira</i> spp.	36	0	0	36	I
<i>Hydroptila</i> spp.	31	0	0	31	I
<i>Macronemum carolina</i> ...	21	0	0	21	I
<i>Hydropsyche incommoda</i> ..	36	0	0	36	I
<i>Hydropsyche</i> spp.	40	0	0	40	I
<i>Cheumatopsyche</i> spp.	119	2	0	121	II
<i>Polycentropus</i> spp.	72	0	0	72	I
<i>Oecetis</i> spp.	67	1	0	68	II
<i>Leptocella</i> spp.	49	2	0	51	II
<i>Chimarra</i> spp.	76	0	0	76	I
Pyralididae	38	0	0	38	I
Simuliidae	89	0	0	89	I
<i>Pentaneura</i> nr. <i>monilis</i> ..	83	2	2	87	III
<i>Pentaneura flavifrons</i> ..	26	0	0	26	I
<i>Tanypus stellatus</i>	4	2	2	8	III
<i>Corynoneura</i> spp.	70	0	0	70	I
<i>Spaniotoma</i> spp.	35	1	0	36	II
<i>Tanytarsus exiguus</i>	42	0	0	42	I
<i>Tanytarsus gregarius</i>	32	0	0	32	I
<i>Polypedilum fallax</i>	28	1	0	29	II
<i>Cryptochironomus</i> spp. ..	64	4	2	70	III
<i>Cryptochironomus</i> sp. B. (Joh.)	21	0	0	21	I
<i>Chironomus decorus</i>	60	5	6	71	III
<i>Chironomus</i> spp.	14	3	3	20	III

It should be pointed out that only organisms from Classes I, II and III have been listed in the table. Since the other two classes have little immediate importance in these proposed methods, there seems to be no reason for needless tabulation.

TABLE I (Continued)
Pollutional Distribution

Organism	Clean Water	Moderately Polluted Water	Highly Polluted Water	Total Number Records	Class
Ceratopogonidae	109	5	1	115	III
<i>Physa</i> spp.	98	7	5	110	III
<i>Ferrissia</i> spp.	71	4	2	77	III
<i>Goniobasis</i> spp.	45	0	0	45	I
Sphaeriidae	106	5	1	112	III

DISCUSSION

Indicator Organisms

The group of organisms comprising Class III merits some discussion despite the fact that the presence of these forms indicates little regarding the quality of the water. Although certain of the chironomid larvae and the tubificid worms may be passed over hastily with regard to existence under anaerobic conditions the same does not hold true for nymphs of the mayflies *Callibaetis floridanus* and *Caenis diminuta*, nor for one unidentified damselfly nymph. Their ability to survive in waters containing no dissolved oxygen is unexplained, though real.

As stated above, a reduction in dissolved oxygen is the first effect of an organic pollutant. Thus dissolved oxygen is of primary importance in stream quality investigations. Modifications of the Winkler method for the determination of dissolved oxygen give very accurate results for a simple and rapid analysis. There are, however, many variables which must be taken into consideration when interpreting dissolved oxygen figures. Corrections for factors such as temperature, barometric pressure and salinity may be applied by use of tables or nomographs which may be found in many books and shorter publications. Factors such as algal blooms and natural pollutional effects which influence the oxygen concentration must be evaluated by other methods. It will thus be seen

that dissolved oxygen may not be used as a single measure of stream condition with any reliability.

Pure water is not found in streams. A stream without dissolved solids and gasses would be sterile due to lack of nutrients for the lower organisms at the base of the food chain. If one wished to take an extreme viewpoint he might consider the addition of any solid, liquid or gas to a body of water as pollution. In a sense this is true, and the concept of natural pollution must be considered in any evaluation of stream condition. It is not proposed in the present report to discuss the subject of natural pollution at any great length. Special work on this subject is being carried on at present by the Florida State Board of Health and will be reported on at a later date. It will suffice to say here that natural pollution does not interfere with the use of the methods outlined in the present report.

The following excerpts are from Gaufin and Tarzwell (1952:62): "In evaluating aquatic organisms as indicators of pollutional conditions, great caution must be used because of several complicating ecologic conditions. First, many organisms which occur in extremely polluted water may also be found in limited numbers in cleaner situations. Several species of invertebrates, such as the mosquito, *Culex pipiens*; beetle, *Tropisternis* spp.; and sludgeworms, *Limnodrilus* and *Tubifex* spp., which occurred in abundance at Stations 6.5 and 5.2 [polluted waters] also occurred in the clean-water zones. Second, many species listed in Table 2 occurred in such small numbers as to discourage their individual use as indicators. Third, several ecologic factors other than the presence of a pollutant may limit the distribution of certain species; for example, erosion, floods, the size of the stream, the type of bottom, the flight range of the insect, and the portion of the stream under study. It is believed that moderate abundance of single species should not be considered as biological indicators of pollution because organisms such as *Tubifex* usually associated with polluted areas are also found in clean waters. It is the complex or association of organisms which is important for indicating clean or polluted water. All organisms present and their relative abundance must be considered."

Under the first qualification in the above quotation, the four genera listed are members of Classes III and IV in the present study and need not prove deterrents to the use of indicator organisms.

Rare or uncommon organisms would be listed in Class V and would thus not prove misleading. The third factor listed by Gaufin and Tarzwell can hardly be answered briefly. It must be assumed that the person performing such a survey will be an aquatic biologist with a reasonable knowledge of stream ecology.

A review of the literature of stream pollution biology will show that indicator organisms may be used basically in two ways—to indicate the presence of pollution or to indicate the absence of pollution. If an attempt is made to establish a program utilizing the macroscopic invertebrates and based on the concept that there are such organisms which by themselves indicate pollution, then it is my belief that the program must fail. No macroscopic invertebrate has been found in Florida which, by itself, indicates pollution. On the other hand, an effective indicator organism program based on species which indicate absence of pollution can be developed quite easily. I am in complete agreement with Gaufin and Tarzwell when they say that the complex or association is of greatest importance as an indicator of stream conditions.

Diversity of Fauna

In the introduction it was stated that two approaches to this program were to be examined simultaneously—indicator organisms and diversity of fauna. The latter approach was abandoned for one main reason. It became apparent after careful examination of many of the streams of Florida that diversity of fauna was primarily the result of one factor—the diversity of habitat. Studies of the nutrient content of Florida waters have lagged seriously behind studies of other factors, primarily due to the lack of accurate and simple field methods for the quantitative determination of these nutrient elements. It seems probable, however, that above certain limits, the nutrient content would exert a quantitative rather than a qualitative effect on the biotic association.

ACKNOWLEDGMENTS

The taxonomic aspects of this study have been, and remain, complex. I am greatly indebted to the following people for their generous assistance:

Drs. C. Francis Byers and Minter J. Westfall, University of Florida (Odonata); Dr. Lewis Berner, University of Florida (Ephemeroptera); Dr. H. H. Ross, University of Illinois (Trichoptera); Dr.

Horton H. Hobbs, Jr., University of Virginia (Decapoda); Mr. Leslie Hubricht, Danville, Virginia (Amphipoda); Dr. James G. Mackin, Texas Agricultural and Mechanical College (Asellidae); Dr. Arden R. Gaufin, Public Health Service (Plecoptera); Dr. Walter G. Moore, Loyola University (Porifera).

For giving generously of their time for discussions of various aspects of the present study and of stream behavior in general, I am grateful to the following: Drs. A. F. Bartsch and H. Page Nicholson, Public Health Service; Dr. Willis M. Van Horn and Mr. Robert Balch, Institute of Paper Chemistry; Dr. Ruth Patrick and her associates, Academy of Natural Sciences of Philadelphia; Dr. F. C. W. Olson, Florida State University; Dr. Maurice W. Provost, Florida State Board of Health.

In this study I have been dependent on the following men for aid in the taxonomy of the midges of the family Chironomidae: Drs. Willis W. Wirth and Alan Stone, United States Department of Agriculture and Dr. Selwyn S. Roback, Academy of Natural Sciences of Philadelphia.

SUMMARY

A simplified method for the biological detection and measurement of organic pollution is presented. This method utilizes indicator values for selected macroscopic invertebrates. These values are determined by prolonged sampling of waters of known condition with regard to organic pollution.

The methods herein described will enable one man to obtain significant biological data with rapidity and economy. With certain faunal revisions these methods may be adapted easily for use in other geographical or political areas.

REFERENCES CITED

- BARTSCH, A. F.
1948. Biological Aspects of Stream Pollution. *Sew. Works Journ.*, 20: 292-302.
- COOKE, C. WYTHE
1939. Scenery of Florida, Interpreted by a Geologist. *Fla. Geol. Survey, Bull.*, 17: 1-118, illus.
- FERGUSON, G. E., *et al.*
1947. Springs of Florida. *Fla. Geol. Survey Bull.*, 31:1-196, illus.
- GAUFIN, ARDEN R., and CLARENCE M. TARZWELL
1952. Aquatic Invertebrates as Indicators of Stream Pollution. *Public Health Rep.*, 67: 57-64.

HENDERSON, CROSWELL

1949. Value of the Bottom Sampler in Demonstrating the Effects of Pollution on Fish-food Organisms and Fish in the Shenandoah River. *Prog. Fish-cult.*, 1949 (Oct.): 217-230, illus.

HERRING, JON L.

1951. The Aquatic and Semiaquatic Hemiptera of Northern Florida. Part 4: Classification of Habitats and Keys to the Species. *Fla. Ent.*, 34: 146-161.

KOLKWITZ, R., and M. MARSSON

1908. *Oekologie der pflanzlichen Saprobien*. *Ber. d. Deut. Bot. Gesell.* 26a: 505-519.
1909. *Oekologie der tierischen Saprobien*. *Int. Rev. d. ges. Hydrobiologie u. Hydrographie.* 2: 126-152.

LACKEY, JAMES B.

1941. The Significance of Plankton in Relation to the Sanitary Condition of Streams. *Symposium Hydrobiology*. Univ. of Wisconsin Press, Madison. 311-328.

PATRICK, RUTH

1949. A Proposed Biological Measure of Stream Conditions, Based on a Survey of the Conestoga Basin, Lancaster County, Pennsylvania. *Proc. Acad. Nat. Sci. Phila.*, 101: 277-341.
1953. Aquatic Organisms as an Aid in Solving Waste Disposal Problems. *Sew. and Ind. Wastes*, 25: 210-217.

RICHARDSON, ROBERT E.

1921. The Small Bottom and Shore Fauna of the Middle and Lower Illinois River and Its Connecting Lakes, Chillicothe to Grafton; Its Valuation; Its Sources of Food Supply and Its Relation to the Fishery. *Ill. Nat. Hist. Survey Bull.*, 13: 363-522.
1925. Changes in Small Bottom Fauna of Peoria Lake, 1920-1922. *ibid.*, 15: 327-388.
- 1925a. Illinois River Bottom Fauna in 1923. *ibid.*, 15: 391-422.
1928. The Bottom Fauna of the Middle Illinois River, 1913-1925. *ibid.*, 17: 387-475.

ROGERS, J. SPEED

1933. The Ecological Distribution of the Craneflies of Northern Florida. *Ecol. Mono.*, 3: 1-74, illus.

VAN HORN, WILLIS M.

1949. The Biological Indices of Stream Quality. *Proc. Fifth Ind. Waste Conf.*, Purdue Univ.: 215-222.

THE OCCURRENCE OF BISON IN FLORIDA

H. B. SHERMAN
University of Florida

Evidence that modern bison occurred in Florida is given by several authors. The expedition of Marcos Delgado encountered bison a few miles west of Marianna, Jackson County, Florida in 1686, according to Boyd, 1936 and 1937; 7, 23. Bison also occurred on Santa Rosa Island and between Pensacola Bay and the Apalachicola River in 1693, Swanton, 1938, 1941. John Bartram records bison from East Florida in his travels of 1773-74 according to Harper, 1943; 198. Boyd's account, 1949, of the expedition of Diego Pena contains dates and localities where 33 bison, 13 cattle and 51 deer were killed during a journey from St. Augustine to southern Georgia and Alabama in 1716. This report shows that two bison were killed near Newnan's Lake, Alachua County; August 13; three east of Itchetucknee Spring, Columbia County; August 20; and many bison were encountered between the Suwannee and Aucilla Rivers where 13 were killed, August 24 to 30. In the vicinity of Tallahassee and Lake Jackson, bison and cattle were abundant and eight bison were killed in these parts of Leon County, September 7 and 8.

While it is thus apparent that northern Florida was a part of the geographical range of the American bison, few specimens known to belong to that species have been found in the state. Many parts of the skeleton, including teeth, of the bison are so similar to those of cattle of similar size, that it is often impossible to decide to which of these species individual bones should be assigned. The first published record of a specimen of *Bison bison* from Florida is that of John M. Goggin, 1951: 176, who states that at least one bison bone, a part of a humerus, was taken from an excavation at the site of Fort Pupo. This site is situated on the west bank of the St. Johns River about three miles south of Green Cove Springs, Clay County, Florida. Goggin gives reasons for believing that this fort must have been constructed during the early part of the 18th century and it was demolished about July 22 or 23, 1740. Articles excavated here consequently apparently date from the early 18th century.

The part of the humerus mentioned by Goggin was identified by me. It consists of a part of the head and shaft, including the

deltoid tuberosity. The bone had been gnawed and most of the lateral and medial tuberosities are lacking. For this reason it is impossible to make use of the characters mentioned by Barbara Lawrence, 1951, for distinguishing the humerus of *Bison* from *Bos*.

The small size and shape of the deltoid tuberosity shows that this was from a bovine animal rather than a horse. Its size indicates that it came from a large animal, but it was also young for the epiphysis had not fused with the shaft.

It is probable that this bone cannot be from domesticated cattle for all available evidence shows that Florida cattle were small until recent years. In George H. Dacy's "Four Centuries of Florida Ranching" 1940, p. 32, he states: "The dual purpose cows from Portugal and Spain, which were brought to Florida by way of Santo Domingo, were small in size but mighty in ability to withstand hardship." Dacy and other authors point out that the so-called native Florida cattle were able to survive in spite of the Texas fever tick which was often fatal to improved breeds. Dacy states, p. 31, "Around 1905 'Sam' Summerlin imported a carload of Hereford bulls, cows and yearlings from Texas, which he placed on his range at East Gardner, after feeding at Tampa for six weeks. That shipment like the millrun of importations of the period, was sacrificed to the Texas ticks." Dacy also states that it was not until 1924 that an effective program for dipping cattle was started in this state which has since resulted in the eradication of the Texas fever tick in most parts of the state.

The size of Florida native cattle is also mentioned by John M. Scott, 1912; 63, who states:

"At the present time there are about eight hundred thousand head of cattle in Florida. Perhaps 95% of these are the native Florida cattle, which are no doubt descended from the old Spanish stock, with little or no improvement. It is stated, however, that many cattle were shipped into Florida from North Carolina, South Carolina, Alabama and Georgia. This influx of cattle from states further north took place from 1840 to 1850, and perhaps before then. At that time cattle must have been similar to our native cattle, as four- to six-year-old steers weighed from 350 to 500 pounds.

What were probably the first efforts toward the improvement of the native cattle took place about 1845. About this time Mr. McKinnon of Walton County imported direct from Scotland a large Shorthorn bull. This bull did good service for a number of years.

The improvement over the native cattle was noticeable. The size of the grade cattle was larger, the four-year-old steers weighing 450 to 750 pounds."

Food is another factor which undoubtedly contributed to the small size of native Florida cattle. Scott showed that native cattle, when well cared for and well fed weighed slightly more than crosses between native cows and hereford and shorthorn bulls. At about two and half years they weighed about 700 pounds. Scott states, p. 67:

"If the calves in the foregoing experiment had been turned out on the open range to hustle for themselves, they would doubtless on March 1, 1910 have been from 25 to 50 per cent lighter than when weaned on October 28, 1909. This heavy loss in weight would be due to the fact that during the winter season the pastures are very poor, and if forage is not supplied (which is not done by the majority of stock raisers), the animals are almost starved. Under these adverse conditions our native cattle never grow and develop as they should, or as they would if supplied liberally with forage during the season when the pastures do not supply sufficient grazing."

At the time of the occupation of Fort Pupo it seems probable that cattle in Florida were no better cared for than in the early part of the 20th century, and were no larger.

The Fort Pupo humerus, no. 972 Dept. Biology University of Florida (DBUF), was compared with three other humeri as follows: Female *Bison bison*, no. 2494, Museum of Natural History, University of Kansas, which was taken in Beaver County, Oklahoma, November, 1888. Brahma bull, no. 2675 of the author's collection, which was furnished me by Mr. T. A. Peeler, General Manager of Swift and Co., Ocala, Florida. Live weight of this animal was 1,040 pounds. A cow, no. 149 DBUF. This skeleton was found in the flatwoods near Gainesville, Florida. The teeth were much worn indicating that this was an old individual.

The relative size of these humeri are shown in the accompanying figure, which was prepared by Miss Esther Coogle. Each sketch of the four humeri was made to show a longitudinal section of the bone in a plane through the pit at the base of the lateral tuberosity adjacent to the bicipital groove and over the greatest extent of the head. The large size of the Fort Pupo specimen leaves no reasonable doubt that this is a bison bone instead of that of Florida native

cattle. The size of the shaft of this bone in comparison with that of the female bison leads to the interpretation that the Fort Pupo specimen was a male.

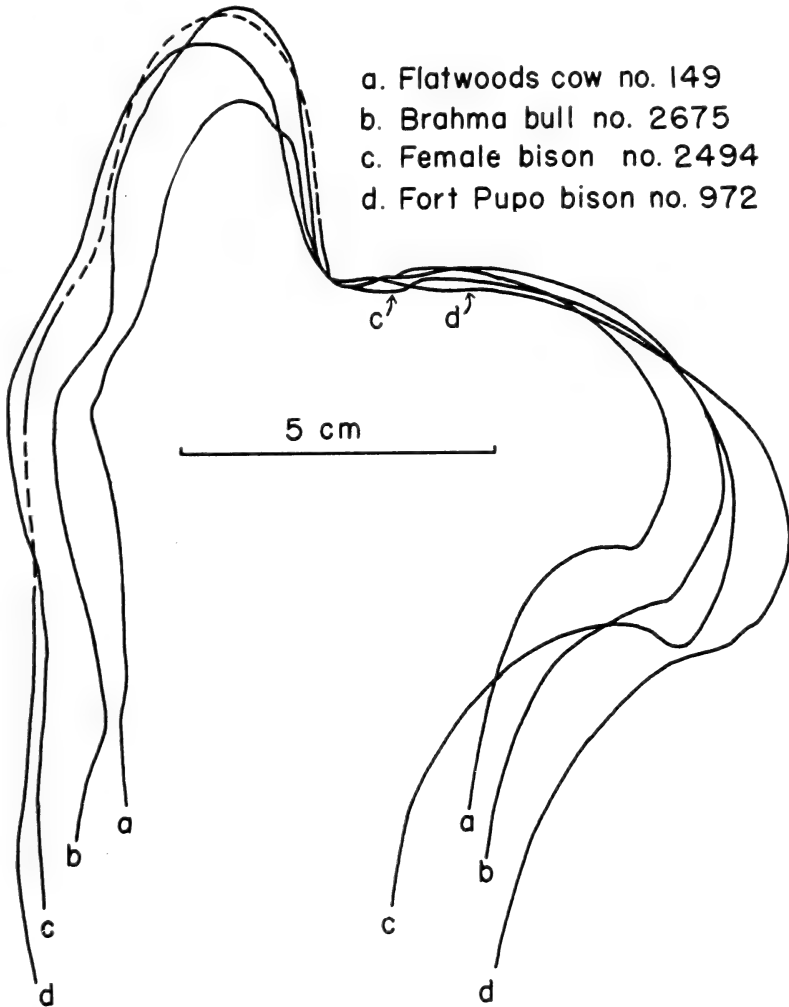

From the same excavation at Fort Pupo four carpal bones were found, 974, 975, 976 and 978, DBUF. These are larger than those of the Brahma bull mentioned above, for which reason they are considered to represent *Bison* rather than *Bos*.

LITERATURE CITED

BOYD, MARK F.

1936. The occurrence of the American bison in Alabama and Florida. *Science*, 84 (2179): 203.
1937. The expedition of Marcos Delgado from Apalache to the Upper Creek Country in 1686. *The Florida Historical Quarterly*, 28(1):1-27.

DACY, GEORGE H.

1940. *Four Centuries of Florida Ranching*. Printed privately.

GOGGIN, JOHN M.

1951. Fort Pupo: A Spanish frontier outpost. *The Florida Historical Quarterly*, 30(2): 139-192.

HARPER, FRANCIS

1943. Travels in Georgia and Florida, 1773-74. A Report to Dr. John Fothergil. William Bartram. Annotated by Francis Harper. *Trans. American Phil. Soc.*, n.s. 33, pt. 2.

LAWRENCE, BARBARA

1951. Post-cranial skeletal characters of deer, pronghorn, and sheep-goat with notes on *Bos* and *Bison*. *Papers of the American Arch. and Eth. Harvard University*, 35(1): 9-43.

SCOTT, JOHN M.

1912. Native and grade cattle-breeding. *Univ. Florida Agr. Exp. Sta., Bull.*, 110.

SWANTON, JOHN R.

1938. Notes on the occurrence of bison near the Gulf of Mexico. *Jour. Mamm.*, 19(3): 379-380.
1941. Occurrence of bison in Florida. *Jour. Mamm.*, 22(3): 322.

A DESCRIPTION OF THE LARVAE OF *AMBYSTOMA*
CINGULATUM BISHOPI GOIN, INCLUDING AN
EXTENSION OF THE RANGE

SAM R. TELFORD, JR.
University of Virginia

The reticulated salamander, *Ambystoma cingulatum* Cope, has recently been found to be considerably more abundant and widespread than hitherto suspected. The larva, whose pattern and coloration is strikingly different from that of the adult, has also been recently brought to light. Further data on distribution and larval forms are presented herein.

There is little published information on this species. Orton (1942) first described the larva of *A. cingulatum* from three small preserved specimens from northwest Florida. Her identification was made by a process of elimination. Although the pattern description is good, no color information is presented since the specimens had evidently been bleached by the preservative. Goin (1950) obtained enough adult material to describe the specimens from the western part of the range as a new subspecies, *A. cingulatum bishopi*. Mecham and Hellman (1952: 129) described from life the larva of the eastern race, *A. cingulatum cingulatum*.

The writer is indebted to Mr. Robert E. Hellman for his careful criticism and advice concerning this paper.

On April 14, 1954, the writer, with the assistance of Dr. Horton H. Hobbs, Jr., and Miss Jean E. Pugh, both of the University of Virginia, collected three larvae of *A. c. bishopi* from a roadside ditch in Newton County, Mississippi, 10.7 miles west of Chunky on U. S. Route 80. The larvae were seined from among unidentified dead aquatic plants in a ditch ten to thirty feet wide, approximately one hundred yards long, and six to twenty-four inches deep. The bottom was muddy, and the water was dark because of the presence of tannic acid. Thick grass and shrubbery border the ditch, and the surrounding terrain is fairly open pine flatwoods. This locality represents a range extension of approximately 180 miles northwest of Mobile County, Alabama, formerly the westernmost known locality for *A. cingulatum*.

The larvae were preserved in the field in five percent formalin, and color notes were taken about three hours later. A yellow-brown

ventro-lateral stripe extends from the posterior margin of the lower jaw to the region of the vent. Laterally, a similarly colored stripe runs from the base of the gills to the region of the vent, breaking up into a fairly close series of large yellow spots on the tail. There is a slightly lighter yellow-brown vertebral stripe extending from the head back along the base of the dorsal crest. The ventro-lateral, lateral, and vertebral stripes are separated by slightly wider black stripes. The dorso-lateral black stripes extend well back on the tail, but the sub-lateral black stripes break up in the region of the hind limbs. The ventral surface is dark grey, with a faint, narrow light line along the mid-ventral blood vessel. The ventral surface of the head is dark grey, well mottled with yellow-brown. The yellow-brown dorsal surface of the head is mottled in the center with dark brown. A broken stripe, dark grey in color, passes along the lower surface of the upper jaw, and a narrow, black band extends from the nostril posteriorly through the eye to the anterior base of the gills. The two lateral head stripes are separated by a wide, light yellow band. The dorsal crest of the tail fin is light yellow-brown with small, dark flecking anteriorly, which darkens to black distally. There are occasional light gold flecks along the anterior part of the dorsal crest. The ventral crest of the tail fin is black and only slightly mottled with yellow. The anterior and posterior limbs are dark grey, slightly banded with yellow-brown dorsally, and darkening to black on the feet. In life, the gills are bright red.

The lateral and ventro-lateral light stripes are slightly brighter than the other yellow-brown areas on the larva, but in general the larvae are far less colorful than the *Ambystoma c. cingulatum* larvae reported by Mecham and Hellman (*loc. cit.*). This may, of course, be due to the fact that the Mississippi larvae are 20 mm. to 30 mm. shorter than the Florida larvae, or to staining action of the tannic acid in the water. Measurements and other pertinent data on the three specimens are as follows:

For purposes of comparison, the same characters used by Mecham and Hellman (*op. cit.*: 131) were checked in these specimens. Only from specimen "A" were the third gill arches dissected out to determine the number of gill rakers. An attempt was also made on this specimen (the largest of the series) to count the larval vomerine teeth, but unfortunately an accurate count was impossible because of the small size of these teeth.

	A	B	C
Total length	51 mm.	43.5 mm.	47.5 mm.
Snout-vent length	24 mm.	22 mm.	23.5 mm.
Head length	8.5 mm.	9 mm.	9.5 mm.
Head width	7.5 mm.	7 mm.	7.5 mm.
Axilla-groin length	12 mm.	11 mm.	11.5 mm.
Gill rakers (anterior face, third arch)	6 - 7	-----	-----
Costal grooves (axilla to groin, all forks)	15 - 15	14 - 14	14 - 14

Mean ratios, determined from the above data, are presented in the table below along with comparative ratios for *A. c. cingulatum*, based on the data of Mecham and Hellman (*loc. cit.*). As may readily be seen, the two forms exhibit considerable differences in larval proportions. These results are minimized, however, by the relatively small numbers of specimens upon which they are based, and the notable size differences in the two series.

Characters	<i>A. c. cingulatum</i>	<i>A. c. bishopi</i>
Head length/snout-vent length363	.389
Head width/snout-vent length274	.314
Axilla-groin/snout-vent length516	.496
Head width/head length729	.816
Number of specimens	4	3

These larvae have been deposited in the writer's personal collection, and designated as SRT No. 889 A,B,C.

LITERATURE CITED

GOIN, COLEMAN J.

1950. A study of the salamander *Ambystoma cingulatum*, with the description of a new subspecies. *Ann. Carnegie Mus.*, 31(14): 299-321; pl. 1.

MECHAM, JOHN S., and ROBERT E. HELLMAN

1952. Notes on the larvae of two Florida salamanders. *Quart. Journal Florida Acad. Sci.*, 15: 127-133; pl. 2.

ORTON, GRACE L.

1942. Notes on the larvae of certain species of *Ambystoma*. *Copeia*, 1942(3): 170-172; 1 fig.

ANATOMICAL STUDY OF SLASH PINE GRAFT UNIONS

FRANCOIS MERGEN¹

Lake City, Florida, Research Center
Southeastern Forest Experiment Station

INTRODUCTION

Incompatibility between stock and scion is often suggested as a possible explanation for graft failures. These incompatibilities might be caused by a number of factors such as the formation of an impermeable contact layer between stock and scion, anatomical differences between the tissues being grafted, or physiological differences such as osmotic pressure of cell sap or difference in plant metabolites (Daniel, 1894, 1928; Proebsting, 1926; Bradford and Sitton, 1929; Herrero, 1951; Mosse and Herrero, 1951). These factors either separately or in combination can delay or completely prevent the formation of a union.

The inherent factors which cause the failure cannot be changed. However, some of the factors which cause these failures might be primarily of a physical nature. Purely physical factors such as formation of an isolation layer might be modified by environmental changes. A study of the anatomical processes connected with the union of grafted tissue is essential for a better understanding of this phenomenon.

There are many reports on callus formation in graft unions in the horticultural and pomological literature, but these reports vary so much from species to species that they are of little value in solving a specific problem with a different species. No report could be located which describes the anatomical features of a graft union in the genus *Pinus*.

Since the morphological and anatomical processes appear to be important in grafting studies, a study of the histological features of graft unions should prove of fundamental importance in the field of grafting.

¹ This article is based on part of a thesis entitled "Rooting and grafting slash pine (*Pinus elliottii*, Engelm.) for application in forest tree genetics" submitted to the Graduate School of Yale University in partial fulfillment of the requirements for the degree of Doctor of Philosophy. The author wishes to express his thanks to Drs. B. H. Paul and M. Y. Pillow of the Forest Products Laboratory for taking the photomicrographs.

In this experiment, cross sections of the various stages during the knitting of slash pine graft unions were studied to find out whether past failures in grafting slash pine scions on slash pine stock failed because of inherent incompatibilities or because of faulty grafting techniques. The information obtained might reveal better grafting techniques for the resinous pines either by modifying the grafting techniques themselves or the environment under which the grafts are kept.

REVIEW OF LITERATURE

Anatomical studies of graft unions have been the object of a number of investigations because the effect of rootstock on scion presents one of the important problems in horticulture. Mendel (1936) and Roberts (1949) reviewed most of the outstanding works on the histology and anatomy of graft unions in horticultural plants. Roberts stated that "many theoretical questions in graftage remain unanswered. . . . Neither technical studies in botany nor practical experience in agriculture have contributed a satisfactory answer to the question of how to predict a successful graft combination."

The histology of healing is dependent upon the type of plant materials. Different patterns of meristematic activities are associated with the various plants. The conclusions of several authors are quoted to give a perception of the diversity of results obtained in the various studies. To quote Eames and MacDaniels (1925): "The important practices of budding and grafting have as their basis the ability of the cambium of both stock and scion to develop callus and unite." Juliano (1941), studying the callus development in graft unions of *Nothopanax* spp., stated that "no evidence of any notable cambial participation in the production of callus tissue was noticed, . . . callus cushions are first formed in the gap through the activity of the parenchyma of both the bark and the pith, and the ray cells of both symbionts." Sass (1932) working with apple grafts found that "no proliferation occurs during the first growing season from the xylem rays . . . callus is produced exclusively by tissues outside of the xylem cylinder. Any living tissue of the bark, excluding the periderm, may proliferate."

The results of the various studies, however, revealed that the anatomical changes involved in the formation of a union are basically

the same; namely the formation of some type of contact layer, generation of callus tissue, differentiation of the callus, elimination of the contact layer, establishment of vascular connections between stock and scion, and the formation of a common cambium. The differences in callus referred to above are not differences in types of tissue but in the source of the callus.

Working with white pine, Riker *et al.* (1943) emphasized the necessity of wrapping the cut surfaces of the stock and scion securely together to hinder the formation of a resinous barrier between them. Mirov (1940), however, looked upon the resin which exudes during the grafting as being beneficial to the success of a union. He felt that the exuded resin helped to cover the cut surfaces of the stock and scion and thus prevent drying of the tissue. Zack (1949) tested the hypothesis that the removal or holding back of the resin from the cut surfaces until stock and scion had been securely fastened would increase the number of successful grafts. The treatments tried by Zack, however, decreased the number of successful grafts. Beside holding back the resin, they probably also destroyed the meristematic tissue along the cut surfaces of both stock and scion.

MATERIAL AND METHODS

During the latter part of November, 1952, five 8-month-old slash pine seedlings were planted in a large clay pot. These seedlings had been selected on the basis of uniformity of size and vigor and were placed in the same clay pot to provide a uniform environment for their subsequent development. In late January, 1953, scion material from 10-month-old nursery-grown seedlings was grafted on the potted seedlings using a side-slit method. The scion and the stock were bound together with waxed nylon twine. Grafting wax was applied after binding to seal out air and water.

A 1-inch layer of moist peat moss was placed around the seedlings and they were covered by a cloche to maintain a high relative humidity around the plants. The object was to permit the various grafts to develop under relatively uniform environmental conditions. At the time of grafting, the plants were 6 inches tall and .15 inch in diameter at the ground line.

The unions for study were collected at weekly intervals, the first being collected one week after grafting. Formalin-acetic acid-

alcohol was used as a killing and fixing fluid. To soften the tissue, glycerin was added to the solution after the unions had been fixed for 3 weeks. The graft unions were imbedded in paraffin and the sectioning of the woody material was facilitated by treating the trimmed blocks prepared for sectioning in ice water for 24 hours. Radial sections were cut about 15-20 microns thick on a rotary microtome. Most of the mounted slides were double-stained with safranin and fast green, while several sections were stained using the quadruple stain: crystal violet, fast green, safranin, and orange G. No attempt was made to obtain differential staining between the stock and scion, but the identity of each was preserved throughout the study. Some 50 sections were mounted permanently in Permount. Only one union was sectioned at each stage to be investigated but it is felt that the samples are fair representations of the various stages since very uniform stock and scion material was grafted under almost identical environmental conditions.

THE ESTABLISHMENT OF A UNION IN SLASH PINE

The first graft was collected 7 days after establishment; therefore, no observations are available on the sequence of cell division during the first week. In the first sections examined, callus formation was already pronounced. The contact layer between stock and scion, which was formed by killed cells along the cut surfaces, by coagulated cell contents, and by oleoresin, had been eliminated in several places and transfusion windows had been formed. Parenchymatous cells from the medullary rays, the phloem rays and the cortex were particularly active in bridging the contact layer and in forming direct connections between stock and scion tissues (Figure 1). The cut ends of some of the medullary rays of the stock appeared fan-shaped when examined in cross-section. Cell proliferation from the medullary rays had assumed a wedge-shaped pattern and started to fill the space between stock and scion. There was some activity in the cambial region, although it was not as far advanced as in the parenchymatous tissue of the rays, phloem or cortex.

The filling-in of the space between both symbionts was mostly with callus tissue derived from the medullary rays (Figure 2).

This filling-in appeared to follow a systematic pattern, and after 3 weeks (Figure 2) a large portion of the cavity had been filled.

The tissue was tender, especially where it connected with the tracheids of the cut surfaces, and was easily torn during sectioning. At some levels of the union the cavity had completely filled after a 3-week period. Some callus was derived from the scion but the stock contributed the greater proportion. Cambium of the stock and scion had united in the lower part where the lip of the stock covered the outer wedge-shaped part of the scion. Transfusion windows along the outer part of the union were pronounced between medullary rays and the phloem or cortex parenchyma. Callus formation around the phloem region was very extensive and progressed outward to the periphery of the cortex. The tissue formed was relatively uniform and it was difficult to distinguish between tissue derived from cambium or phloem parenchyma cells.

Where the pith was exposed during grafting, heavy proliferation developed from its parenchyma cells and it proceeded to fill the cavity in the outward directions as a result of the pressure applied to the union. Five weeks after grafting, the cavity between the symbionts had been filled and some of the newly-formed tissue

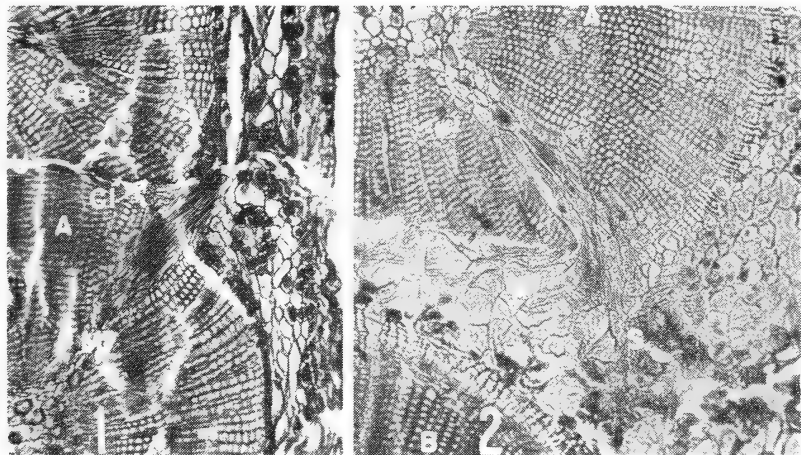

Figure 1.—Cross section through a 1-week-old graft union showing the early activity of a medullary ray (M). Most of the activity was from the stock (A) part. The contact layer (C) along the line of union (U) was formed from cells of both stock and scion (B). X58.

Figure 2.—Cross section of graft union 3 weeks old, showing filler callus (P) which is derived from both stock (A) and scion (B). The callus formation is pushed into the space between the graft symbionts as a suberized layer (S) limits the outward proliferation of the filler callus. X58.

started to differentiate. Callus from the various elements had grown together and produced a compact tissue and cambium cells of the symbionts had joined in localized regions.

In a lower region, where the pressure applied by the binding was not sufficient, the extensive proliferation of the pith developed enough pressure to split the scion (Figure 3). The rupture probably occurred along the ray cells, and the separated parts of the scion were pushed outward by the callus tissue formed by the pith parenchyma cells.

The complete elimination of the contact layer was apparent 6 weeks after grafting (Figure 4). The tissue in the filled cavities showed various stages of differentiation. Many of the callus cells had developed into cambial cells, and started to bridge the cambial ends of the stock and the scion along most of the union. The cambium was continuous in 8 out of 10 sections analyzed. Some of the callus cells were transformed into conducting elements. Phloem, cortex and periderm of the stock and scion had united and formed continuous layers. By this time the scion was growing very vigorously and had added 1 inch of height growth.

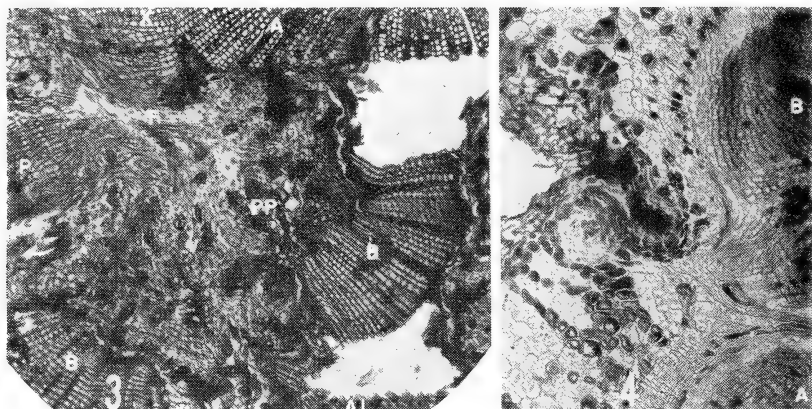

Figure 3.—Cross section through the lower part of a union where the scion (B) was held by the lip (AL) of the stock (A). The pressure supplied by the binding was not great enough to force the newly-formed tissue in between the surfaces of the symbionts. The extensive proliferation of the pith parenchyma cells (PP) split the scion (B) in two. This section illustrates some of the growth 5 weeks after grafting: a transfusion window (T) and differentiated callus tissue (P). As many as 12 layers of xylem cells (X) had been laid down by the stock plant since grafting. X42.

Figure 4.—Radial section of 6-week-old union. The contact layer has been eliminated and the cell differentiation of the filler tissue is quite advanced. A is the stock part while B is part of the scion. X42.

DISCUSSION AND CONCLUSION

The observations made on the newly formed graft unions suggest that there are no inherent factors which make slash pine scions and rootstock incompatible. Incompatibilities between graft partners, however, might not be apparent for some time. In some instances there is a complete failure to unite, while in other cases growth starts, but gradually diminishes (Bradford and Sitton, 1929). In this study, only the early behavior of slash pine graft unions was investigated, and no effort was made to obtain information on the mechanical strength of these unions after they had been established.

Unobstructed contact between the two cambia was made in well-matched grafts. The space between the cut surfaces of the grafting partners became filled in by the spongy callus tissue and the pressure applied by the binding compressed the newly-formed cells until their respective origins became indistinguishable. Most of the wound tissue was the product of the stock, apparently because the initial shock suffered by the stock was not as great as that of the scion.

The regenerative importance of the cambium cells in grafting appears to be overemphasized in the wood anatomy literature. This study illustrated beyond reasonable doubt that wound callus is not only produced by the meristems already present at the time of grafting but that parenchymatous cells of the pith, medullary rays, phloem and cortex can assume meristematic functions. These findings corroborate the conclusions by Juliano (1941) in his study of *Nothopanax* unions.

The contact layer, which is formed by the death and shrinkage of the cells, was most pronounced in the regions of the cortex, phloem, cambium, and pith. A thin layer of exuded oleoresin covered part of the wound; the early proliferation of the active meristematic tissues probably prevented the formation of a continuous resin layer. The even pressure supplied by the binding along the smoothly-cut surfaces prevented the formation of oleoresin pockets. In his studies of graft unions between guayule and sunflower, Artschwager (1951), observed that the thickness of the contact layer depended to a large extent upon the smoothness of the cut and the pressure holding the stock and scion together. When the contacting surfaces were uneven and not under pressure, the

contact layer was broad and irregular and often broke apart, leaving an air-filled cleft between scion and stock. The correct binding and the application of an even pressure along the cut surfaces is of great importance in the knitting of a union.

The knitting process of the union was probably more rapid with the material under study than can be expected with scions from old trees. In the young pine branches, cells remain meristematic for a longer period of time than in older tissue (Delisle, 1942). However, the general pattern of union formation with scion material from older trees should be very similar to the one described if the grafting cuts are made in the current year's growth of the grafting partners.

Judging from these findings, there exists no reason to ascribe failures in grafting slash pines to anatomical inability to bridge the union. The failures can be caused by faulty grafting techniques, unsuitable grafting material, wrong season of the year, or by an unfavorable environment. If proper grafting techniques, together with a suitable environment, are used, a large percentage of success in grafting slash pines should be obtained.

SUMMARY

An anatomical study of the sequence of the knitting of a union in young slash pines showed that parenchymatous cells of medullary rays, phloem, cortex, and cambium, participated in bridging the space between stock and scion tissues. The stock contributed the greatest part of the wound tissue, but the scion took part in callus formation. A continuous bridge between respective anatomical parts of the graft partners was apparent after 6 weeks.

LITERATURE CITED

ARTSCHWAGER, E.

1951. Anatomical studies on graft unions between guayule and sunflower. *U.S.D.A. Tech. Bul.* 1040: 23-26.

BRADFORD, F. C., and B. G. SITTON

1929. Defective graft unions in the apple and the pear. *Mich. Agric. Expt. Sta. Tech. Bul.* 99. 105 pp.

DANIEL, M. L.

1894. Recherches morphologiques et physiologiques sur la greffe. 2e partie.-Physiologie. *Rev. Gen. Bot.*, 6: 60-75.
1928. Sur la formation des thylls chez les plantes greffées. *Compt. rend. Acad. Sci. (Paris)*, 187: 58-60.

- DELISLE, ALBERT L.
1942. Histological and anatomical changes induced by indoleacetic acid in rooting cuttings of *Pinus strobus* L. *Virginia Jour. Sci.*, 3(5): 118-124.
- EAMES, ARTHUR J., and LAURENCE H. MacDANIELS
1925. *An introduction to plant anatomy*. McGraw-Hill Book Co., Inc., XIV + 364 pp.
- HERRERO, J.
1951. Studies of compatible and incompatible graft combinations. *Jour. Hort. Sci.*, 26(3): 212-237.
- JULIANO, JOSE B.
1941. Callus development in graft union. *Philippine Jour. Sci.*, 75: 245-254.
- MENDEL, KURT
1936. The anatomy and histology of the bud-union in Citrus. *Palestine Jour. Bot. and Hort. Sci.*, 1:13-46.
- MIROV, N. T.
1940. Tested methods of grafting pines. *Jour. For.*, 38: 768-777.
- MOSSE, B., and J. HERRERO
1951. Studies on incompatibility between some pear and quince grafts. *Jour. Hort. Sci.*, 26(3): 238-245.
- PROEBSTING, E. L.
1926. Structural weakness in interspecific grafts of *Pyrus*. *Bot. Gaz.*, 82: 336-338.
- RIKER, A. J., T. F. KOUBA, W. H. BRENER and L. E. BRYAM
1943. White pine selections tested for resistance to blister rust. *Jour. For.*, 41: 753-760.
- ROBERTS, R. H.
1949. Theoretical aspects of graftage. *Bot. Rev.*, 15(7): 423-463.
- SASS, JOHN E.
1932. Formation of callus knots on apple grafts as related to the histology of the graft union. *Bot. Gaz.*, 94(2): 364-380.
- ZACK, B.
1949. Importance of resin in the grafting of shortleaf pine. Unpubl. M.F. Thesis, Duke Univ., 34 pp.

MODERN WHOLESALE MARKET FACILITIES

RAY Y. GILDEA, JR.
University of Florida

What causes the strong interest today concerning modern wholesale markets? For one thing people in the field of marketing farm produce are influenced primarily by need. They are constantly faced with the problem of handling more and more produce in overcrowded and unsanitary conditions. The answer appears to be to enlarge the present facilities, or better still, to build new, modern structures. After new markets have been erected, the builders then become aware of numerous benefits that were not always apparent. Thus the benefits were not the driving force towards new efficiency. It was an awareness of the existing confusion that has finally brought action.

TABLE I
Defects in Existing Wholesale Market Facilities

	St. Louis	Miami	Norfolk	Richmond
Population'	1,500,000 1946	350,000 1945	400,000 1947	320,000 1951
Carload equivalent Fruits and vegetables	39,420	27,000	9,000	7,200
<i>Defects</i>				
Lack of rail connections	X	X	X	X
Difficulty of enforcing regulations	X	X	X	X
Lack of proper design for efficient handling	X	X	X	X
Lack of farmers' facilities ..	X		X	X
Heavy traffic congestion	X		X	X
Scattering of market facilities	X		X	X
Lack of platforms and handling equipment	X	X		

Source: United States Department of Agriculture and Virginia Department of Agriculture.

The Need. The evidence of the need for improvements or innovations is apparent. For example, a number of defects found existing in the old wholesale markets of St. Louis, Missouri; Miami, Florida; Norfolk and Richmond, Virginia can be cited (Table I). All four markets lacked satisfactory rail connections. The market of each city lacked unity due to definite selling periods or incomplete knowledge of supplies available. By establishing uniform regulations, many problems could have been solved. Three cities—St. Louis, Miami and Norfolk—reported that their markets were too crowded to promote efficient handling of produce, were in heavily congested traffic areas, contained many scattered buildings, and lacked places for farmers to peddle their produce. Miami's market had a particular problem of lacking adequate surface drainage in the market area.

The Aims. Recognizing the existing defects, what then can be done to remedy such problems? A wholesale market should be a carefully designed system of buildings, roads and parking areas which are intended to bring together all of the buyers and sellers of perishable agricultural commodities.

There should be five primary aims of a modern market:

1. To bring all independent produce wholesalers to one location where all farmers can haul their produce.
2. To allow individual farmers to sell their products at one center instead of transporting them from one wholesaler to another.
3. To allow farmers to collect farm produce in abundant volume in order to attract large buyers.
4. To provide parking, unloading, and maintenance facilities for truckers.
5. To reduce the price spread between the farmer and consumer by cutting down on waste and spoilage. (It has been estimated that up to $\frac{1}{3}$ of farm produce raised today is lost in spoilage).

The Site. Once the purposes of a modern market are clearly understood, the next course of action is to select a site. There are four important factors to be considered in choosing a site: (1) land area, (2) location or situation, (3) cost or value, and (4) availability.

Most modern markets now need on the average about 20-25 acres for the site. This figure will allow room for future expansion, a factor which was generally not considered in the past. A city has also

to consider such factors as room for rail connections, and amount of land already owned by an existing market.

If possible, the market should be made convenient to buyers, sellers, and dealers. It also should be located close to major transportation arteries. For example, it is not wise to force truckers to drive through an entire city in order to reach the market. Miami, Florida, well illustrates how careful consideration was given to the factors of land and location. Having investigated the transportation network and amount of land available, this city decided it was more advisable to expand its present site rather than move to a new location.

A basic principle in estimating the maximum cost of the site is that that cost should not exceed 25% of the value of the market plus the value of the land. In determining the amount of revenue necessary to pay off the investment and secure a fair profit, both the construction costs and the land cost are the determining factors. If the proper balance between building and land values is not achieved and the land value is too high, one of two consequences will take place. Either not enough funds will be available for adequate facilities, or rentals will have to be raised above a reasonable level. For example, when considering a new market within the city limits of Miami, the only site containing a sufficient amount of land was the one already in use. Most important, the cost would be in line with the total value of the market. (In this case 26% of the total value). Further, to move the market would split the fruit and vegetable market, since a number of dealers owning improved property within the old site would refuse to move.

Concerning land availability, let us consider the St. Louis problem. The market builders were faced with several factors. Most of the suitable locations were already taken by industrial, mercantile, or residential buildings. In addition, downtown St. Louis is often confronted by the flooding Mississippi River, limiting the choice of site considerably. Also, a large portion of the city is not adequately serviced by rail facilities. After looking into these problems in detail, the Prairie Avenue site stood out above all other locations. While this area was somewhat far removed from the geographic center of retail distribution, nevertheless, it was more accessible to out-of-town buyers and more convenient to rail connections. Further, a great deal of non-market traffic would be excluded, and the cost of the site was reasonable.

The Facilities. The next step is the placement of facilities on the selected site. What facilities must there be in order to carry out the aims and purposes previously stated? There appear to be at least ten essential ingredients for an up-to-date produce market:

1. Stores for wholesale dealers of fruits, vegetables, poultry, eggs, and other farm products. It might be stated here that the size of a wholesale unit for a modern market is generally considered to be 22½ feet by 60 feet. The number of units each dealer needs depends entirely upon his business volume. However, in order to build a market, 40 units (or 54,000 sq. ft.) are an absolute must.

2. Farmers' and truckers' sheds and auction blocks for the sale of local farm produce. A lack of farmers' and truckers' facilities has always been an important problem in the past.

3. Rail connections to stores and team tracks. This is especially important in view of the amount of bulk commodities and rail shipments that are handled by wholesale markets.

4. Adequate parking space. An often-neglected but highly important feature. Get the cars and trucks off the street.

5. Wide, paved streets. Avoid traffic jams and market confusion.

6. Durable fences. Insure adequate protection for market property.

7. Refrigeration plant. Insure freshness, prevent spoilage, promote attractive displays, and store surplus foods.

8. Public refrigeration warehouse. (Could be combined with item No. 7). This is designed for outsiders who need refrigerated storage space and for odd surplus storage by local dealers.

9. Assembling, processing, and packing sheds for fruits, vegetables, poultry, etc. This service feature permits dealers to handle commodities adequately without working in crowded stores.

10. A central office. Promote unity, better management, and central control.

Other services could well include a service station, rest rooms, and a restaurant for use by all concerned with the market.

Financing. How does one go about paying for this market? There are four generally accepted methods for financing:

1. Private corporation financing, run on a profit basis. Bonds

would be floated and profit rendered on the basis of holdings. Sound financing and sound management are the keys to the permanency of this method.

2. A city or state agency participates by lending a certain percentage of the total cost, the balance to be provided by private funds. For example, Virginia is about to pass a bill establishing a revolving loan fund to be used in building wholesale markets. The state is prepared to lend up to $\frac{1}{3}$ of the total cost of each project in order to insure the availability of sufficient private capital to complete each structure. Each loan is for a reasonable period of time and carries a reasonable rate of interest. In the question of the Richmond and Norfolk markets, each city has set up a Market Authority that is responsible for the attraction of private capital and the repayment of the loan.

3. A public non-profit corporation. Such a corporation would probably be administered by a city, financed by taxes, and profits returned to the public in the form of lower marketing costs and possibly better handling of food. A variation of this would be a private, non-profit organization, financed by one or several wealthy philanthropists.

4. A farmer-wholesaler cooperative organization. This association would be run on a strictly cooperative basis with profits returned to those participating in the form of lower operating costs. The success of this venture again depends in great measure upon sound management.

It may be seen that there are numerous methods for financing new wholesale facilities. The method chosen should, of course, be tailored to fit the needs of the individual city.

Benefits. Who benefits from having a modern wholesale market? People. What people? Little people and big people.

The Farmer Benefits. If marketing costs can be reduced, the farmer may receive a larger percentage of the selling price for his products. Public demand for food may increase, making the farmer produce more. In addition, farmers who use modern markets will benefit from all the education and research that has gone into the establishment of such efficiency.

The Wholesale Dealer Benefits. This type of individual is helped greatly. For one thing, he can supply better service at possibly less cost. He is no longer battling overcrowded conditions but now can

attract more business by handling improved quality in quantity. More attractive displays and more satisfactory refrigeration facilities are further points in his favor.

The Independent Retail Grocer Benefits. He saves time in buying and handling by shopping in one central place with efficient facilities. Modern markets generally offer retailers a wider selection of better quality foodstuffs. The better quality produce, in turn, will eliminate future waste and spoilage in his store.

The Independent Chain Retail Grocer Benefits. He can have a ready supply of produce in large enough quantities so that he does not have to rely on out-of-state shipments.

The City Government Benefits. Improvement in traffic handling is obtained when markets are located away from downtown business districts. Wider streets and adequate parking and unloading areas simplify the city's traffic problem even further. Finally, the city is better able to enforce its sanitation codes in a new, centralized market.

The Consumer Benefits. The consumer is the one who benefits most of all by having a selection of fresh, high-quality produce handled with a minimum of contamination and damage, and refrigerated properly. By having an orderly marketing system, the consumer is paying less in marketing costs. This means that the money saved by this new efficiency goes to the farmer in the form of higher returns and to the consumer in the form of lower prices.

People are realizing today that community progress demands, among other things, adequate wholesale market facilities. The adoption of modern market facilities will provide one important step toward modern community planning.

SELECTED REFERENCES

ELLIOTT, W. H., and A. B. LOWSTATER

1947. *The Wholesale Fruit and Vegetable Market of Miami, Florida.* U. S. Department of Agriculture, Washington, D. C.

NORFOLK CHAMBER OF COMMERCE

1952. *A Wholesale Produce Market for the Norfolk Area.* Norfolk Chamber of Commerce, Norfolk, Virginia.

U. S. DEPARTMENT OF AGRICULTURE, PRODUCTION AND MARKETING ADMINISTRATION

1949. *The Wholesale Produce Market at St. Louis, Missouri.* U. S. Department of Agriculture, Washington, D. C.

Quart. Journ. Fla. Acad. Sci., 17(4), 1954.

THE GEODUCK CLAM IN FLORIDA

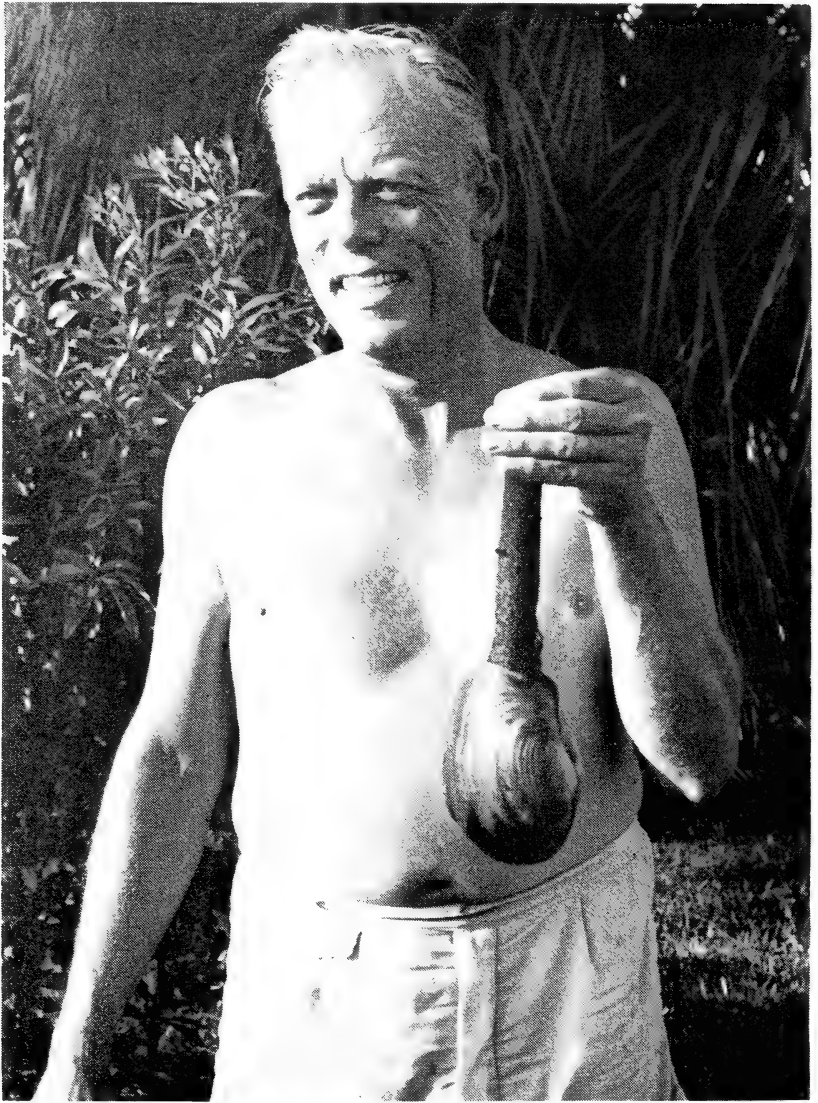

A living specimen of *Panope bitruncata* was collected by the author in the vicinity of St. Augustine, Florida in August, 1954. This is of particular interest to malacologists as R. Tucker Abbott, in his recent book "American Seashells", speculated on the possibility of the species being extinct. The habitat of this marine clam is restricted to a soft substrate covered by a hard layer of sand. The author is shown holding the Geoduck.—Verle A. Pope, St. Augustine, Florida.

... .. 18. p 73-75. d. 4

NEWS AND COMMENTS

This is the last number of the JOURNAL that will come out under the present Editorial Board. The Editor would like to take this opportunity to thank the Associate Editors, Dr. J. C. Dickinson, Jr., Dr. Donald R. Dyer, and Dr. John W. Flowers, for their help and cooperation. He would also like to express to the membership of the Academy his thanks for the opportunity of serving as Editor.

As President-elect your retiring Editor will be charged with the responsibility of conducting a membership drive. Plans are being formulated and will be announced in the not-too-distant future. Think what it would mean to the Academy if every member stirred himself or herself and enrolled just one new member! Dick Edwards has been doing a wonderful job as Secretary-Treasurer. During his term of office we have come out of the "red" and into the "black." As a result every new member on the rolls could mean an increase in the size of the JOURNAL—and it certainly could stand some increasing!

The new Editor has not yet been appointed by the Council. Meanwhile, manuscripts are being received and held for the new Editor.

A new marine biological station, the Cape Haze Marine Laboratory, will be opened at Placida, Florida in January 1955. Situated on Gasparilla Sound, it offers opportunities for studying the fauna and flora of the Gulf of Mexico and will be open to investigators and students in the near future. The laboratory is the first part of a cultural center planned for Cape Haze, a development sponsored by William H. Vanderbilt and Alfred G. Vanderbilt. A museum collection of local fishes and facilities for keeping living specimens have been started. The laboratory will be under the directorship of Dr. Eugenie Clark.

INDEX TO VOLUME 17

- A. A. A. S. Research Grant, 181
- AGNEW, L. R. C., 129
- ALLEN, HOWARD D., 19
- Ambystoma cingulatum bishopi* Goin,
A Description of the Larvae of, In-
cluding an Extension of the Range,
233
- Annual Meeting, Notice of, 82, 184
- ARGUS, MARY F., 129
- AUFFENBERG, WALTER, 185
- BECK, WILLIAM M., JR., 211
- BECKER, HENRY F., 73
- BELLAMY, RAYMOND F., 1
- Bison in Florida, The Occurrence of,
228
- Boron in Florida Waters, 105
- CALDWELL, DAVID K., 182
- Colorimetric Test for Organic Matter
in Certain Mineral Soils, A Rapid,
83
- Crayfish from the Upper Coastal Plain
of Georgia (Decapoda, Astacidae),
A New, 110
- Crime and Social Research, 11
- DANZIG, MORRIS J., 43
- Ecological Classification of Organisms,
A Simplified, 211
- EDSON, SETON N., 83
- Fertilizer for Use in Brackish Water,
A Suggested Inorganic, 119
- Fish Fauna, Additions to the Know.,
in the Vicinity of Cedar Key,
Florida, 182
- Fish Populations by Haul Seine in
Seven Florida Lakes, Adult, 146
- FISHER, GRANVILLE C., 55
- Florida's Resource-Use Education
Problems, 73
- FOX, VERNON, 140
- Frustration-Aggression Hypothesis in
Corrections, The, 140
- GARRETT, FREDERIC D., 55
- Gavialosuchus americanus* (Sellards)
from a New Locality in Florida,
Additional Records of, 185
- Geoduck Clam in Florida, The, 252
- Geometry, Some Methods for the
Treatment of Problems in Dimen-
sional, 19
- GILDEA, RAY Y., JR., 246
- GRACE, H. T., 168
- HOBBS, HORTON H., JR., 110
- JOHNSON, MALCOLM C., 119
- Membership List, 59
- MERGEN, FRANCOIS, 237
- Method for Preparing Thin Cross
Sections of Human or Other Large
Brains, A, 55
- MOODY, HAROLD L., 147
- MOZINGO, HUGH NELSON, 46
- News and Comments, 71, 128, 253
- NIELSEN, C. S., 25, 87
- ODUM, HOWARD T., 105
- Officers for 1955, Elected, 210
- Oscillatoriaceae, The Multitrichomate,
of Florida, 25, 87
- Palms in Florida, A Vegetative Key to
the Native and Commonly Culti-
vated, 46
- PARRISH, BRUCE, 105
- Phosphate Industry, A Regional Study
of the, 168
- POPE, VERLE A., 252
- Relations of People to Each Other, 1
- SCHULTZ, HARRY P., 43
- SHERMAN, H. B., 228
- Slash Pine Graft Unions, Anatomical
Study of, 237
- Stream Pollution Biology, Studies in,
211
- Synthesis of 3-Amino-4-nitrobenzoic
Acid and Ethyl 3-Amino-4-nitro-
benzoate, A Simplified, 43
- TELFORD, SAM R., 233
- THORNTON, GEORGE D., 83
- Tumor Chemotherapy, Studies of
Fluorene Derivatives, 129
- VEDDER, CLYDE B., 11
- Wholesale Market Facilities, Modern,
246

INSTRUCTIONS FOR AUTHORS

Contributions to the *JOURNAL* may be in any of the fields of Sciences, by any member of the Academy. Contributions from non-members may be accepted by the Editors when the scope of the paper or the nature of the contents warrants acceptance in their opinion. Acceptance of papers will be determined by the amount and character of new information and the form in which it is presented. Articles must not duplicate, in any substantial way, material that is published elsewhere. Articles of excessive length, and those containing tabular material and/or engravings can be published only with the cooperation of the author. Manuscripts are examined by members of the Editorial Board or other competent critics.

MANUSCRIPT FORM.—(1) Typewrite material, using one side of paper only; (2) double space *all* material and leave liberal margins; (3) use 8½ x 11 inch paper of standard weight; (4) do not submit carbon copies; (5) place tables on separate pages; (6) footnotes should be avoided whenever possible; (7) titles should be short; (8) method of citation and bibliographic style must conform to *JOURNAL* style—see Volume 16, No. 1 and later issues; (9) a factual summary is recommended for longer papers.

ILLUSTRATIONS.—Photographs should be glossy prints of good contrast. All drawings should be made with India ink; plan linework and lettering for at least ½ reduction. Do not mark on the back of any photographs. Do not use typewritten legends on the face of drawings. Legends for charts, drawings, photographs, etc., should be provided on separate sheets. Articles dealing with physics, chemistry, mathematics and allied fields which contain equations and formulae requiring special treatment should include India ink drawings suitable for insertion in the *JOURNAL*.

PROOF.—Galley proof should be corrected and returned promptly. The original manuscript should be returned with galley proof. *Changes* in galley proof will be billed to the author. Unless specially requested page proof will not be sent to the author. *Abstracts* and *orders for reprints* should be sent to the editor along with corrected galley proof.

REPRINTS.—Reprints should be ordered when galley proof is returned. An order blank for this purpose accompanies the galley proof. The *JOURNAL* does not furnish any free reprints to the author. Payment for reprints will be made by the author directly to the printer.

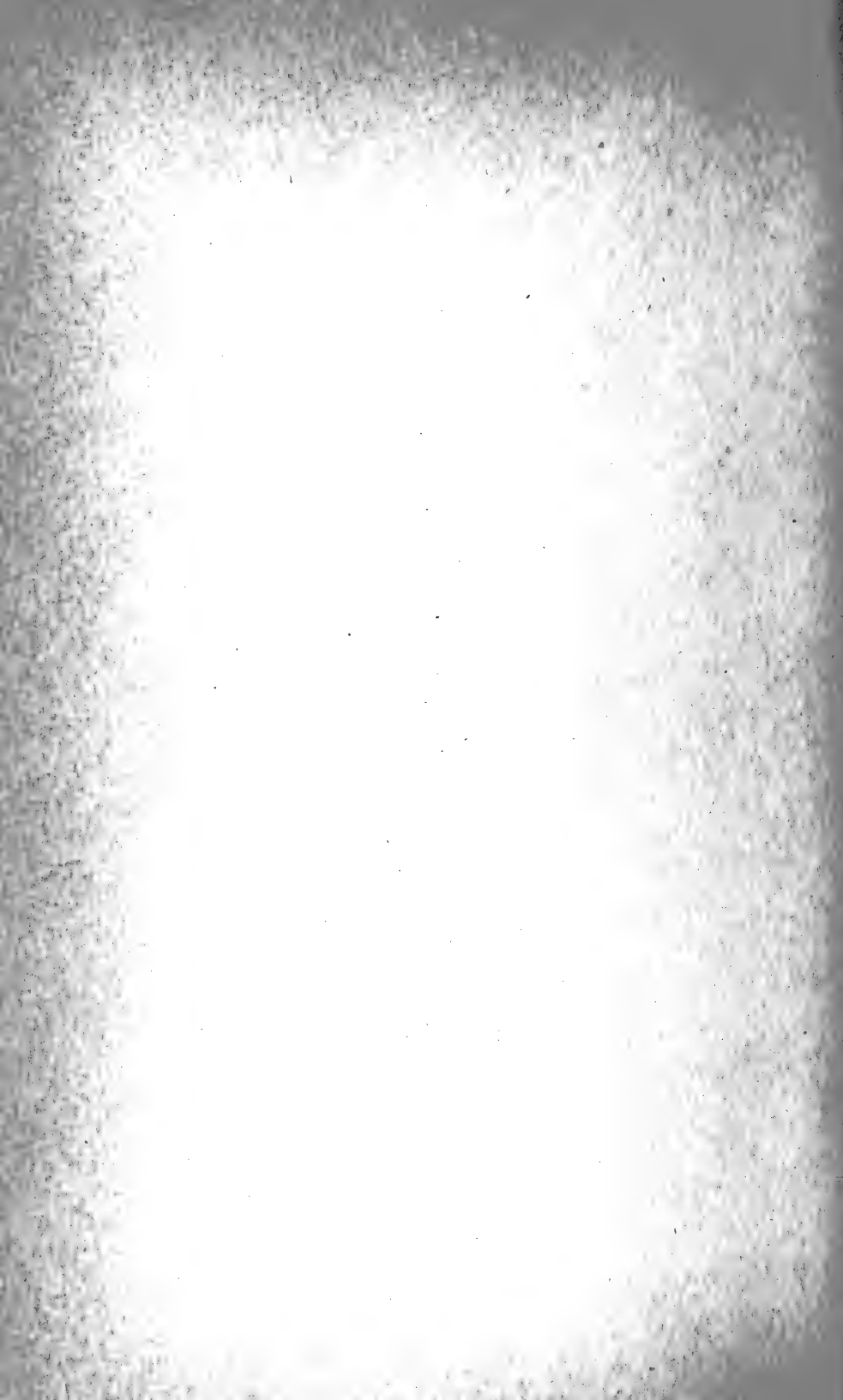

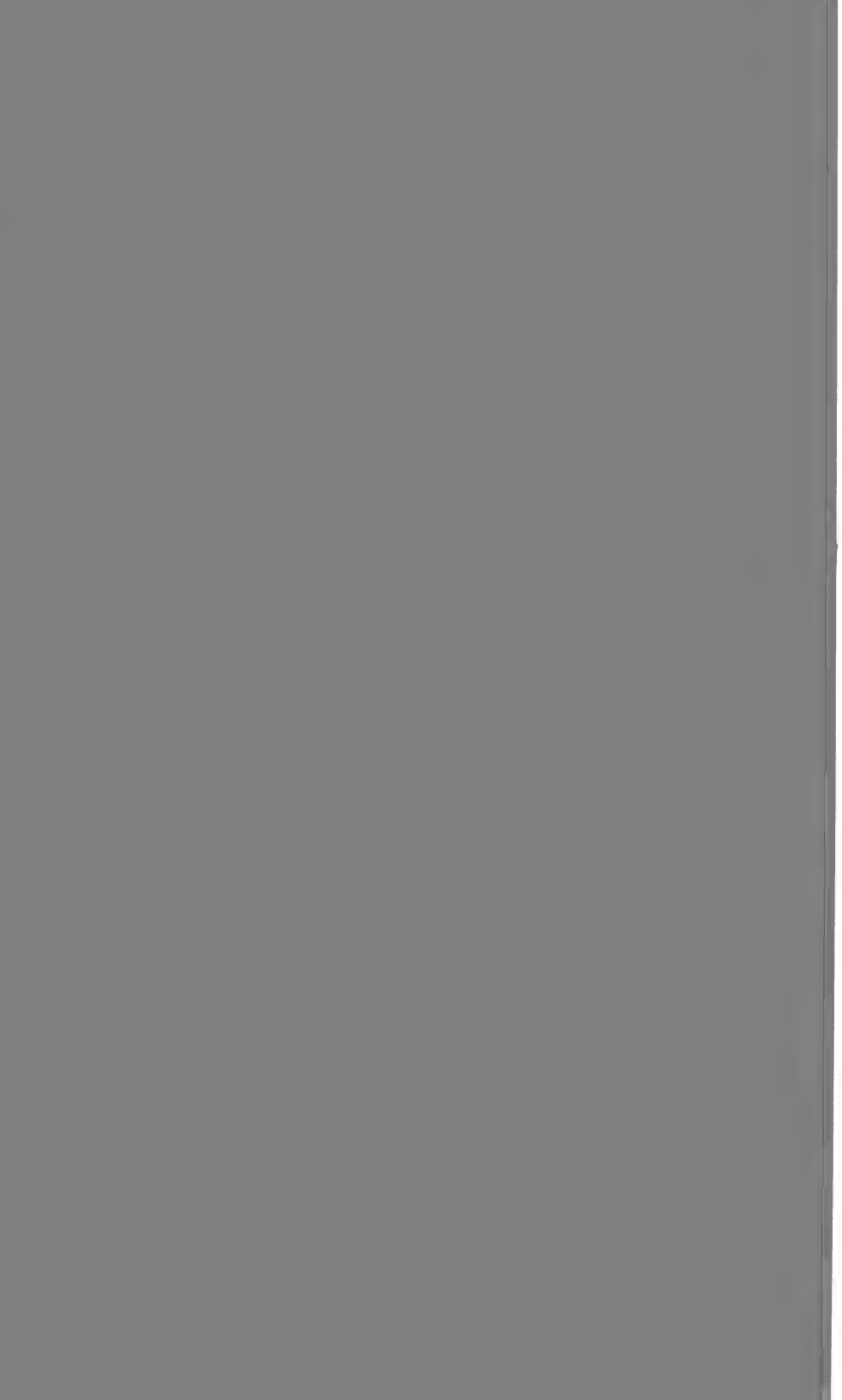



The Quarterly Journal of The Florida Academy of Sciences

A Journal of Scientific Investigation and Research

J. C. DICKINSON, JR., *Editor*
JOHN D. KILBY, *Associate Editor*

VOLUME 18

Published by
THE FLORIDA ACADEMY OF SCIENCES
Gainesville, Florida
1955

DATES OF PUBLICATION

Number 1—May 17, 1955

Number 2—September 9, 1955

Number 3—November 30, 1955

Number 4—May 8, 1956

CONTENTS OF VOLUME 18

NUMBER 1

The Southeastern Species of <i>Baetisca</i> (Ephemeroptera: Baetiscidae). <i>By Lewis Berner</i>	1
The Glossy Ibises of Lake Alice. <i>By Dale W. Rice</i>	20
Observations on the Ecology of the Low Hammocks of Southern Florida. <i>By Taylor R. Alexander</i>	21
A Method of Exposing the Gastric Glandular Mucosa of Mice to Carcinogenic Agents. <i>By Michael Klein and Mary F. Argus</i>	28
Monogenetic Trematodes of Gulf of Mexico Fishes. Part III. <i>By William J. Hargis, Jr.</i>	32
Further Additions to the Known Fish Fauna in the Vicinity of Cedar Key, Florida. <i>By David K. Caldwell</i>	48
The Aged Population of Florida: Number, Proportions, and Characteristics. <i>By Irving L. Webber</i>	49
A Preliminary Survey of the Water Beetle Fauna of Glen Julia Springs, Florida. <i>By Frank N. Young</i>	59
A New Race of <i>Myotis austroriparius</i> from the Upper Mississippi Valley. <i>By Dale W. Rice</i>	67
Food of the Mudfish (<i>Amia calva</i>) in Lake Newnan, Florida, in Relation to its Management. <i>By Frederick H. Berry</i> ...	69
Twentieth Anniversary	76

NUMBER 2

Notes on the Distribution, Spawning, and Growth of the Spot-tailed Pinfish, <i>Diplodus holbrooki</i> . <i>By David K. Caldwell</i>	73
Florida Oscillatoriaceae III. <i>By C. S. Nielsen</i>	84
Monogenetic Trematodes of Gulf of Mexico Fishes. Part VII. <i>By William J. Hargis, Jr.</i>	113
Some Records of Hemiptera New to Florida. <i>By Roland F. Hussey</i>	120
Effect of a Long Shaft on the Polarization of Skylight. <i>By A. G. Smith and M. L. Vatsia</i>	123
Book Review	125
Organization for 1955 Annual Meeting	128

NUMBER 3

The Decapod Crustaceans of Alligator Harbor and Adjacent Inshore Areas of Northwestern Florida. <i>By Marvin L. Wass</i>	129
Florida Oscillatoriaceae III. <i>By C. S. Nielsen</i>	177
American Education and the Stone Wall. <i>By G. G. Becknell</i>	189
A List of Fishes from the Southern Tip of the Florida Peninsula. <i>By John D. Kilby and David K. Caldwell</i>	195
Metachrosis in Snakes. <i>By Wilfred T. Neill and E. Ross Allen</i>	207
A Biological Soil Test for Available Phosphorus by Spontaneous Growth of Soil Organisms. <i>By James P. Flavin and Seton N. Edson</i>	216
Hermaphroditism in a Mouse Related to Strain A. <i>By Michael Klein</i>	223
A.A.A.S. Research Grants	226

NUMBER 4

Subsurface Beach Sands of Alligator Harbor. <i>By Neil Hulings and F. C. W. Olson</i>	227
Jacksonville and Miami: Urban Contrast in Florida. <i>By Donald R. Dyer</i>	233
Report on the Academy Conference	238
A Survey of the Economic, Educational and Social Resources of Bradford County, Florida. <i>By H. T. Grace</i>	239
Review of the Genus <i>Doldina</i> Stal (Hemiptera: Reduviidae). <i>By Roland F. Hussey and Joe C. Elkins</i>	261
A Nest of the Atlantic Leatherback Turtle, <i>Dermochelys cori- acea coriacea</i> (Linnaeus), on the Atlantic Coast of Florida, with a Summary of American Nesting Records. <i>By David K. Caldwell, Archie Carr and Thomas R. Hellier, Jr.</i>	279
The Characteristics and Distribution of the Spotted Cusk Eel, <i>Otophidium omostigmum</i> (Jordan and Gilbert). <i>By John C. Briggs and David K. Caldwell</i>	285
Natural History Notes on the Atlantic Loggerhead Turtle, <i>Caretta caretta caretta</i> . <i>By David K. Caldwell, Archie Carr, and Thomas R. Hellier, Jr.</i>	292
Interaction of Pi^- Mesons with Light Nuclei. <i>By Joseph Callaway</i>	303

506.73
F 6683

Quarterly Journal

of the

Florida Academy

of Sciences

Vol. 18

March, 1955

No. 1

Contents

Berner—The Southeastern Species of <i>Baetisca</i> (Ephemeroptera: Baetiscidae)	1
Alexander—Observations on the Ecology of the Low Ham- mocks of Southern Florida	21
Klein and Argus—A Method of Exposing the Gastric Glandular Mucosa of Mice to Carcinogenic Agents	28
Hargis—Monogenetic Trematodes of Gulf of Mexico Fishes. Part III	33
Webber—The Aged Population of Florida: Numbers, Proportions, and Characteristics	49
Young—A Preliminary Survey of the Water Beetle Fauna of Glen Julia Springs, Florida	59
Rice—A New Race of <i>Myotis austroriparius</i> from the Upper Mississippi Valley	67
Berry—Food of the Mudfish (<i>Amia calva</i>) in Lake Newnan, Florida, in Relation to Its Management	69
Research Notes—Caldwell and Rice	20, 48

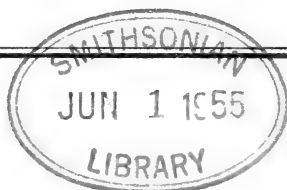



VOL. 18

MARCH, 1955

No. 1

QUARTERLY JOURNAL OF
THE FLORIDA ACADEMY OF SCIENCES

A Journal of Scientific Investigation and Research

Editor—J. C. DICKINSON, JR.

Associate Editor—JOHN D. KILBY

Published by the Florida Academy of Sciences

Printed by the Pepper Printing Co., Gainesville, Fla.

The business offices of the JOURNAL are centralized at the University of Florida, Gainesville, Florida. Communications for the editor and all manuscripts should be addressed to the Editor, Department of Biology. Business communications should be addressed to R. A. Edwards, *Secretary-Treasurer*, Department of Geology. All exchanges and communications regarding exchanges should be addressed to The Gift and Exchange Section, University of Florida Libraries.

Subscription price, Five Dollars a year

Mailed May 17, 1955

THE QUARTERLY JOURNAL OF THE FLORIDA ACADEMY OF SCIENCES

VOL. 18

MARCH, 1955

No. 1

THE SOUTHEASTERN SPECIES OF BAETISCA (EPHEMEROPTERA: BAETISCIDAE)¹

LEWIS BERNER²
University of Florida

The last complete summary of the mayfly genus *Baetisca* was given by Needham, Traver, and Hsu in 1935. These authors re-described the five species known at that time and mentioned the description of *B. bajkovi* by Neave (1934), published after their manuscript had gone to press. The discovery of two new species, *B. thomsenae* Traver (1937) and *B. rogersi* Berner (1940), brought the total of recognized forms to eight. In this paper, I am presenting the description of two additional new species which have been collected in the southeast within the past few years.

The species of *Baetisca* are widely distributed over eastern North America, occurring from Lake Winnipeg southward to north-central Florida. A single species, *Baetisca obesa*, was reported by Eaton (1883-1887) from California; no other representative of the genus has since been reported in the literature from the western part of the continent. The presently recorded distribution of the North American species is as follows:

Baetisca callosa Traver—West Virginia, New York, Quebec

Baetisca carolina Traver—North Carolina, West Virginia, Tennessee, Quebec

Baetisca bajkovi Neave—Manitoba, Illinois, Indiana, Minnesota

Baetisca lacustris McDunnough—Manitoba, Ontario, Ohio

Baetisca laurentina McDunnough—Ontario, Quebec, New Brunswick, Illinois, Michigan

¹ This investigation was supported in part by a research grant, No. G-4058, from the National Institutes of Health, Public Health Service.

² I am indebted to Miss Esther Coogle, Staff Artist, Department of Biology, University of Florida, for the drawings of the *Baetisca* nymphs and for many of the line illustrations in this paper.

Baetisca obesa (Say)—Indiana, Illinois, Michigan, New York, New Hampshire, California, Georgia, Florida

Baetisca rogersi Berner—Florida, Alabama

Baetisca rubescens (Provancher)—Quebec

Until the discovery of the two species herein described, there were only two representatives of the genus reported from the Coastal Plain. If I am correct in my assumptions, *B. rogersi*, *B. escambiensis*, and *B. gibbera* are Coastal Plain species, while *B. obesa* is widespread, occupying much of North America. I believe, however, that it is primarily an inhabitant of lowland streams. *Baetisca carolina* and *B. thomsenae*, synonymized below, appear to be inhabitants only of the Appalachian Mountains and the Piedmont.

Although the pattern of light and dark areas of the wings of *Baetisca* subimagos seems to be variable, I am presenting illustrations of the forewings of three species (Figs. 6, 8, 9). In these, the patterns are definitely unlike, pointing up the desirability of further investigation of this characteristic which may serve to separate the subimagos of this genus.

BAETISCA ESCAMBIENSIS n. sp.

(Figs. 5, 7, 8, 10, 15, 20)

Baetisca escambiensis is entirely distinct from any of the other species of this genus. It differs in the adult stage in having the wings flushed throughout with ruby color; in shape of the penes; and it is the only species in which the eyes are known to be banded with vertical stripes. In the nymphal stage, it is completely different by reason of the unusually long genal and the very long, thin, mesonotal spines, and the lack of frontal projections on the head.

MALE HOLOTYPE: Body length 10.9 mm.; mesothoracic wings 11.3 mm.; caudal filaments 8.4 mm.

Head: Eyes large, almost contiguous. A whitish area extends anteriorly over the vertex and is divided by a heavy, brown, median line. Ocelli large, deep brown at the base; color extends inward as a V-shaped mark toward the median, brown line; median ocellus lies between the arms of the V, and it, too, is extensively brown; area within the arms of the V is mottled brown. Red-brown markings present below the eyes and extending ventrally. Median carina and area below the antennae deep brown. Basal segment of antennae purplish brown; second segment and flagellum brown. Eyes with only a faint indication of a division, the lower portion slightly paler than the upper. Eyes distinctive because of the vertical banding of light and dark areas across their entire surface. The bands begin at the ventral edge of the eye and extend



1



2



3

Fig. 1. Nymph of *Baetisca rogersi*
Fig. 2. Nymph of *B. carolina*
Fig. 3. Nymph of *B. gibbera*

dorsally becoming more distinct in the upper part; they converge toward the ventral part.

Thorax: Pronotum almost completely concealed by the enormously developed eyes; brownish in color; median, brown line present extending the length of the segment. Intersegmental membranes purplish and the membranes between the sclerites also purplish. Mesonotum brown, mottled with lighter color; deepest brown in the central area. At the base of the scutellum there are two large, submedian, oblong, brown marks; remainder pale with margins outlined in dark brown. Metanotum dark brown. Prosternal process deep brown; intersegmental membranes purplish; mesosternum shiny brown; metasternum paler brown. Legs: Forelegs brown, not darker at the articulations; slightly darker at the distal end of the femur and tibia. Coloration of middle and hind legs similar to that of foreleg. Wings: Entire forewing (Fig. 7) and hindwing flushed with ruby; along the costal border the coloration is considerably more intense and extends its full length. Crossveins throughout the costal border are margined with a paler coloration producing a striated appearance; this deeper color extends to the area between R_1 and R_2 . The remainder of the membrane has a delicate flush of ruby. Very close to the base of the wing, and hardly extending beyond the bases of the main veins, there is a brownish tinge. Base of hind wing also colored with reddish-brown which extends up into the costal angle. In the hind wing, the flush of ruby extends throughout the membrane; near the leading edge of the wing and as far as the middle field, the crossveins are margined with paler areas so that there appears to be blocks of deeper ruby color between the crossveins. Longitudinal veins of fore and hindwing are dark with a reddish-brown tinge.

Abdomen: Tergites dark brown; intersegmental membranes give a purplish cast to the posterior border of each of the tergites. The points of former attachment of the gills in the nymphal stage are also outlined with this purplish coloration. On tergites 2-5, there is a very faint, submedian, pale line. Tergites 6-10 with a median, deep-brown line. Adjacent to the median line of tergite 6 and in its anterior half, there are submedian, triangular, pale areas followed by a large, butterfly-shaped, brown area; in the posterior half of the tergite, there is a large, triangular area, which has its apex at the mid-point of the tergite and extends posteriorly with its base on the posterior border of the segment; it is mottled brown, being deep brown toward the middle of the segment. There are large pale blotches in the outer portions of the butterfly-shaped area. The anterolateral portion of tergite 6 is occupied by a large purplish-brown triangular area. Adjacent to the median line of tergites 7-10 there is a lighter brown area, and laterally the tergites are colored with mottled brown that extends to the margins of the segments. Sternites brownish with a purplish tinge, more heavily colored on the lateral margins; middle portions shaded with purplish red which become more intense laterally. Intersegmental membranes purplish. On sternites 7 and 8 there is a large, pale, median, triangular area which is based on the posterior margin of the sternites and extends to about the middle of the segment. Genitalia distinctive (Fig. 20); forceps brown along their outer margins, inner margins pale; penes brown. Caudal filaments brown.

NYMPH: Body length of male nymphs averages 10.6 mm., of females 13 mm.

Head: Genae produced into very long, flat, sharp spines; tipped with deep brown; not upturned at tip. Head mottled with brown. No frontal projections. Antennae pale except at the very tip where they become dusky. Eyes of all nymphs examined are banded vertically as shown in Figure 5. Surface of head tuberculate; however, tubercles are only conspicuous on the genal shelf. Entire margin of head bordered with long hairs.

Thorax: The slightly recurved mesonotal spines, which are sharp and dark tipped, are the most prominent feature of the thorax. Thorax compressed dorsoventrally as compared with other species of *Baetisca* (Fig. 10). Conspicuous, deep-brown marks present as shown in Figure 5; two lateral marks present, one close to the anterolateral corner of the mesonotum, the other somewhat posterior to the first. A third pair of dark brown marks is adjacent to the median line and forms a V-shaped marking about the middle of the mesonotum. Dorsum of mesonotum mottled. Sternum pale except in the median part where there is a brownish area on the mesosternum and in the anterior portion of the metasternum. Entire lateral border of thorax margined with long hairs. Legs: Hairy; clusters of hairs at base of each leg; especially numerous on the femora; no hairs on tibiae and tarsi. Legs pale, unbanded. Claws extremely long and thin (Fig. 15); sharp tipped and golden brown distally.

Abdomen: Lateral margins of segments 6-8 expanded and flared outwards as shown in Figure 5; these segments bordered with long hairs; posterolateral angles terminate in sharp points. Lateral margins of 9 and 10 with only very short hairs; segment 9 also has short, serrate spines on margins. These serrate spines also present on other segments but are partially concealed by the long marginal hairs; serrations begin just before the mesonotal spine and continue posteriorly, becoming more prominent posterior to the spine. Abdominal segment 6 brown on anterior half, posterolateral portions pale; median triangular section posterior to the hump is mottled brown. Tergites 7-10 have a median brown line extending the length of the segment; lateral to the median line on 7 and 8, there is a pale rectangular area; lateral to this and extending almost to the border, the segment is mottled brown; flange translucent. Posterior median portion of tergites 7-9 upturned, although not forming a distinct, posteriorly directed spine (Fig. 10). Ventrally pale; light brown mottling in the anterolateral portions of sternites 3-6. Caudal filaments light brown.

Examination of half-grown nymphs shows that they are very much the same structurally as mature specimens and have similar markings. However, the genal and mesonotal spines are more accentuated, as are the posterolateral spines of the abdominal segments. The upturned posterior edges of segments 7-9 are also more exaggerated. On some young nymphs, the lateral mesonotal spine may be long and thin and half as long as the entire mesonotum; the genal spines are as long as the head. The general spinose appearance of young nymphs rivals that of some of the more bizarre species of membracids.

HOLOTYPE: Male imago (reared) preserved in alcohol. Florida, Escambia County, Escambia River. October 23, 1954. Collected by C. D. Hynes and

L. Berner. Emerged in laboratory on November 6. In the University of Florida Collections.

PARATYPES: 6 males (reared), 5 preserved in alcohol, 1 pinned. Same data as holotype. Emerged in laboratory between November 5 and 14. In the University of Florida Collections.

VARIATIONS: The paratypes are remarkably constant and fit the description of the holotype. They vary only in the slight tendency toward formation of annulations on the tarsal segments of the middle and hind legs.

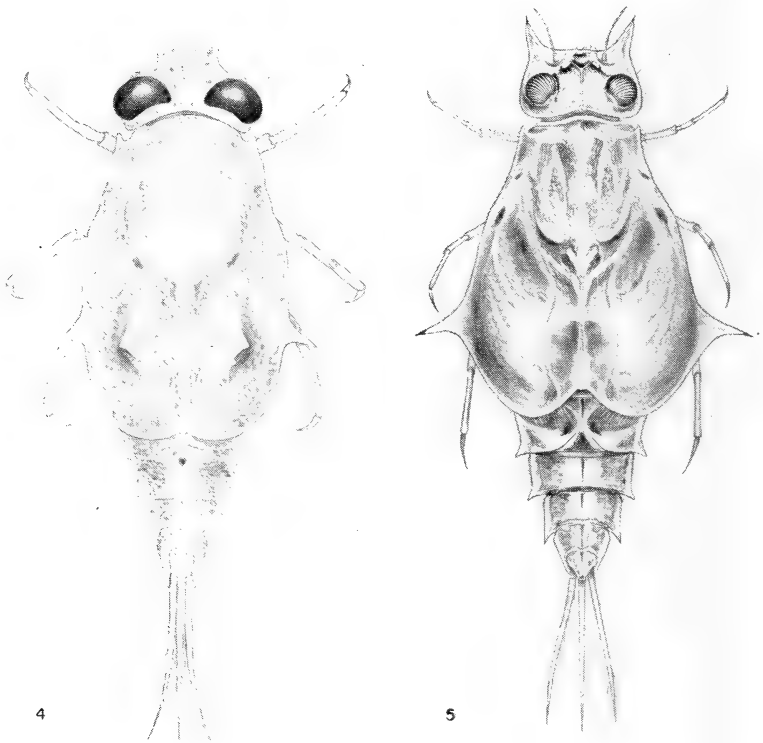

Fig. 4. Nymph of *B. obesa*
Fig. 5. Nymph of *B. escambiensis*

No females were reared to the adult stage although a number of subimagos were obtained. An examination of these immatures indicates that the color pattern of the head, thorax, and abdomen is very much the same as that of the male holotype with only minor differences. The basal segments and the flagellum of the antennae are deep brown in some specimens and in others has the same coloration as that of the male; the face is mostly deep brown. The coxae on the outer sides are colored with deep brown, and the tibiae, in their outer part, and the distal segments of the tarsi of all legs are dark brown. Whether this deeper coloration of the tarsi carries over into the adult stage remains to be determined. The banding of the eyes as seen in the male adults is also present in the female subimagoes.

B. escambiensis nymphs were found on a sandbar in the Escambia River in shallow water from four to five inches up to about one foot in depth, where they lay partially buried in the stream bed. In the area from which the nymphs were taken there was a fine layer of silty mud overlaying the sandy bottom. Where they were most abundant, there was also an admixture of clay in the sand. The current was relatively slow, and in some places there was a growth of algae over the bottom. In almost every place that the *Baetisca* nymphs were found, young *Hexagenia* were also taken. The specimens were collected by the use of a screen held by one person downstream while another kicked up the mud and sand. There was relatively little gravel in the places that the nymphs were found to be most abundant.

Examination of another sandbar, where there was a slight amount of gravel mixed with sand and mud, revealed a few nymphs, but they were not as common as in the first habitat. No more than four nymphs were taken at any one time during the period of collecting on October 23; however, on August 24 they were far more abundant and many nymphs were caught with each disturbance of the sand.

The sandbar which was the most prolific producer of the nymphs was about fifteen feet long and five feet wide (Fig. 23). In August about 50 or 60 nymphs were taken from this bar. During the morning of October 23, in a period of about three hours of hard work, we were able to collect another fifteen mature specimens from the same sandbar. Again in the afternoon we worked an-

other two hours at the same place and found an additional fifteen mature nymphs.

The *Baetisca* nymphs were found on the sloping sides of the sandbar where the shelving was rather steep, the grade being estimated to be roughly about 20 percent. The relatively slow current was deflected laterally across this shallow zone. Where the algae were dense, no *Baetisca* nymphs were found, but where it was sparse and the layer of silty mud overlaying the sand thin, the nymphs appeared to be common.

The Escambia River was clear and colorless at the time of the October collections; the water temperature was 65° F., and was alkaline, as evidenced by the presence of large numbers of snails. The River has a very clean, white, sand bottom with a swift flow in midstream. It is a large river, being about 300 feet across and, at the time we studied it in October, its deepest point was probably not more than about five feet. However, the normal water level of the stream would probably have been around ten to fifteen feet in the deeper regions. This low water level was a reflection of the extremely dry summer that northwestern Florida and southeastern Alabama had suffered in 1954.

The first collection of nymphs was made in August by my assistant, Mr. C. D. Hynes, who discovered them through the painful process of having the spiny insects stick to his arms as he examined material on a collecting screen. As soon as he recognized the nymphs as being those of *Baetisca*, he began collecting a series and was successful in taking a large number. Although we examined the stream in many places in October, we were not often

-
- Fig. 6. Forewing of *B. rogersi*, male subimago
Fig. 7. Forewing of *B. escambiensis*, male adult
Fig. 8. Forewing of *B. escambiensis*, male subimago
Fig. 9. Forewing of *B. obesa*, male subimago
Fig. 10. Profile of thorax and abdomen of *B. escambiensis*, nymph
Fig. 11. Profile of thorax and abdomen of *B. rogersi*, nymph
Fig. 12. Profile of thorax and abdomen of *B. carolina*, nymph
Fig. 13. Profile of thorax and abdomen of *B. gibbera*, nymph
Fig. 14. Profile of thorax and abdomen of *B. obesa*, nymph
Fig. 15. Tarsal claw, right hind leg of nymph, *B. escambiensis*
Fig. 16. Tarsal claw, right hind leg of nymph, *B. gibbera*
Fig. 17. Tarsal claw, right hind leg of nymph, *B. carolina*
Fig. 18. Tarsal claw, right hind leg of nymph, *B. rogersi*
Fig. 19. Tarsal claw, right hind leg of nymph, *B. obesa*
Fig. 20. Male genitalia, *B. escambiensis*
Fig. 21. Male genitalia, *B. obesa*
Fig. 22. Male genitalia, *B. rogersi*

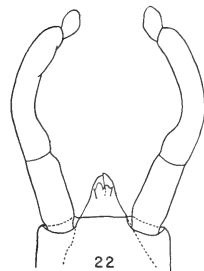
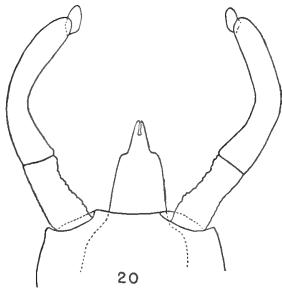
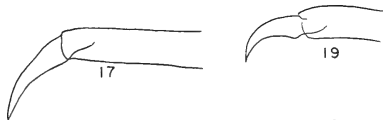
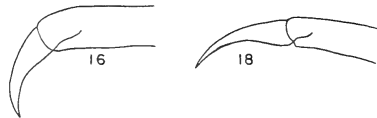
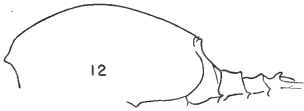
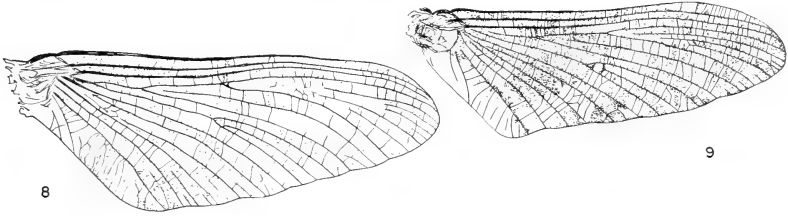
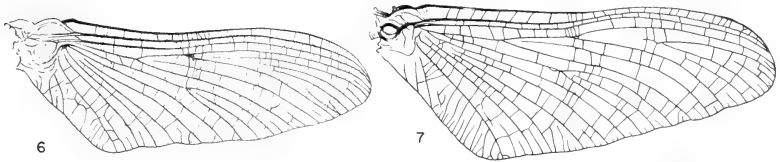

successful in finding the nymphs in other habitats, in spite of the fact that we looked in numerous other shallow, sandy areas that resembled the sandbar from which we collected most of the nymphs.

In the October collections, about 45 nymphs were taken and kept alive. These were brought back to the laboratory for rearing. Despite the long trip to Gainesville and the confinement of the nymphs in gallon plastic containers for nearly 24 hours before being placed in aerated rearing pans, none died.

Observation of the nymphs in the laboratory showed that they lie partially covered in the soft, silty sand with only a small part of the mesonotum and a little of the abdomen protruding above the level of the sand. Most of them were so well concealed that they were not detectable until the sand was disturbed. Their coloration makes it possible for them to blend perfectly with their background.

Even though flowing water was not used in the laboratory for rearing, the insects were kept alive in aerated water in rearing pans as late as November 20. By this date those that had not already emerged finally died. Those that died did so not because of lack of food or air, but simply because they were unable to emerge. Of the 45 nymphs which were kept for rearing, 25 emerged successfully and of these seven male subimagoes molted to the adult stage.

When ready to emerge, the nymphs crawled out of the water onto the air hose or a stick which was kept in the pan. In emerging, they crawled to a distance about one inch above the water level, where they clamped their claws firmly into the support. After several minutes to as much as an hour, the subimago appeared. Earliest observed emergence began at 9:30 a.m. and the latest occurred about 1:30 p.m. Whether this is the time of day the species emerges under natural conditions is still unknown. The average time for the subimagal stage in the laboratory, where the temperature ranged from a low of about 60° F. at night to a high of 75° F. in the daytime, was approximately 40 to 44 hours. Although a number of females emerged, not one was able to undergo the subimagal molt. Because I felt that low humidity might be responsible for the fact that the specimens were unable to undergo their molt, I put them in a chamber in which the moisture was high. Even so, the females were still unable to molt, although they remained alive for as long as four days after emerging.

The nymphs collected in August were half grown. Suspecting that this was probably a late-emerging species, my assistant and I traveled to the Escambia River on October 23 and were fortunate in finding the mature nymphs. These, when brought back to the laboratory, proved that I was correct in my assumptions. November is an unusually late month for emergence of a species of *Baetisca*, especially from the northwestern part of Florida. Other species of *Baetisca* emerge much earlier in the year, usually from February through June. Nymphs of *B. escambiensis* that were taken in August were approximately of the same size; the October specimens were probably from the same brood.

In addition to very young *Hexagenia* sp. nymphs that were taken along with the nymphs of *Baetisca*, nymphs of *Brachycercus* sp. were also collected from the mud in approximately the same place that the *Baetisca* nymphs were found. The *Brachycercus* specimens were also mature and ready to emerge; however, I was unsuccessful in my attempts to rear this species in the laboratory.

BAETISCA GIBBERA n. sp.

(Figs. 3, 13, 16)

A study of available specimens of the various species of *Baetisca* has convinced me that I have a new species of this genus represented only by the nymphal stage. A comparison of my specimens with nymphs of *Baetisca lacustris* from Michigan, as well as with the illustrations of the nymph by McDunnough (1932), reinforces this conviction. The affinities of *B. gibbera* seem to lie with *lacustris* insofar as the structure of the nymph is concerned. The adult is still unknown although nymphs were brought back to the laboratory and kept alive for a period of two weeks in an attempt to rear the species.

Baetisca gibbera differs from all of the known species of *Baetisca* in the shape of the mesonotal spines and the lack of strongly produced frontal and genal processes. The mesonotum is enormously humped; much more so than in most other species. The mesonotal spines are short and blunt, rather than being pointed as in most of the other species.

Because of its distinctive body shape, I am describing this nymph as a new species. It is my opinion that a species is best described

from the form which is most readily differentiated. In the genus *Baetisca*, the nymphal stage is the most useful for this purpose.

HOLOTYPE NYMPH: Body length 7.5 mm.; caudal filaments 2.2 mm.

Head: Genal projections extend only slightly forward in front of the head; broadly rounded at anterolateral corners; projections brown medially and outlined with a clear area of chitin. Frontal projections small, rounded; very slightly elongated at the anterolateral corners (Fig. 3). Remainder of head mostly brownish but deep brown anterior to the eyes. Dark area lateral to antennal base and anterior to compound eye extends out onto the genal shelf. Eyes black. Lateral ocelli just posterior to the antennal bases appear as clear, white spots on the top of the head. Antennae pale; faintly washed with brown. Entire upper surface of head covered with small tubercles. Ventral aspect of genal shelf covered with small tubercles as well as outer parts of mandibles and labrum. Mouthparts like those of other species of the genus.

Thorax: Pronotum covered with the same types of tubercles as those on the head, except that they are somewhat smaller. Mesonotum conspicuously large, being very wide and much humped (Figs. 3, 13). Entire surface tuberculate, but not as distinctly so as the pronotum. Lateral spines short and blunt. Anterior to the lateral mesonotal spines there are sinuous curves as shown in Figure 3. Anterolateral angles of mesonotum extend forward to form a cup into which the head fits and completely enclose the pronotum. No dorsal spines present on mesonotum. On a direct line with lateral spines, there are two large, submedian, white spots and lateral to these there are two additional white spots; an irregular pattern of brownish areas over the whole mesonotum. Metanotum concealed. Ventrally the thorax is also tuberculate. Legs: Femora of all legs tuberculate. Fore femur dark in outer, basal portion; tibia dark on outer side; tarsus banded with brown in medial portion. Mid and hindleg with the coxae dark on outer side; femora dark basally becoming lighter distally; tibiae almost completely covered with brownish shading; tarsi banded medially with brown. Claws of all legs fairly long, tipped with deep amber (Fig. 16). At upper edge, each femur margined with long hairs.

Abdomen: Dorsally all tergites covered with same small tubercles seen on other parts of body; these are much more prominent on posterior margin of tergite 6 than on other tergites; however, they show up well on the lateral margins of the others. No median posterior spines on tergites 7 and 8 but 9 has a short one as illustrated in Figure 13. Tergite 10 with a U-shaped excavation such as found in all other species of this genus; tips of excavation outlined in white. Median line of tergites 7-9 deep brown in anterior half, remainder a fine, white line. Anterior and lateral portions of tergites 7 and 8 shaded with deep brown, median portion lighter; tergite 9 with definite light areas and yellowish blotches. Tergite 10 stippled with brownish blotches. Sternites tuberculate; no distinctive markings. Caudal filaments light brown; median filament slightly darker than the laterals.

HOLOTYPE: Nymph preserved in alcohol. Florida, Escambia County, Escambia River, October 23, 1954. Collected by C. D. Hynes and L. Berner. In the University of Florida Collections.

PARATYPE: 7 nymphs. All specimens in the University of Florida Collections. Florida: Clay County, Black Creek, November 26, 1951, one nymph collected by W. M. Beck; January 25, 1954, one nymph collected by L. Berner; Escambia County, Escambia River, October 23, 1954, one nymph collected by C. D. Hynes and L. Berner. Georgia: Baker County, Ichawaynochaway Creek, November 27, 1953, three nymphs collected by L. Berner; Echols County, Alapaha River, February 2, 1954, one nymph collected by L. Berner.

VARIATIONS: Lateral spines of mesonotum very short and very blunt in one specimen; however, they do form distinct lateral mesothoracic spines. One nymph about a third grown has very long spines which are twice as long in proportion to the width as those of specimens bearing the very shortest spines. The tips of the spines on this long-spined form approach being sharp pointed. Some specimens are intensely blotched with brown on mesonotum and abdomen, and the median line of the abdominal tergites is entirely deep brown. Dark shading on the tibiae is restricted on some specimens to the base just beyond the knee on the outer side.

Baetisca gibbera was first taken in 1951 and reported as *Baetisca* sp. (Berner, 1953). This nymph was collected from Black Creek,



Fig. 23. The Escambia River showing in the foreground the sandbar from which most of the nymphs of *B. escambiensis* were taken. Mr. C. D. Hynes is handling the screen with which the specimens were captured.

a rather swift-flowing, deep, acid stream, where it was found attached to a log. I have revisited the stream and, after a considerable amount of work, took another nymph from a pebbly riffle about 12 inches in depth. Another specimen was taken at the Alapaha River and this nymph, too, was found clinging to the underside of a log that was anchored at the bank of the stream. The Alapaha is a deep, dark-colored stream draining the Okefenokee Swamp. It has a sand bottom and is approximately 100 feet in width. *Baetisca obesa* nymphs were found near the place where the single *B. gibbera* was located.

Three nymphs of *B. gibbera* were collected at the Ichawaynochaway Creek from a pebbly riffle near the shore where the flow was swift. The water was three to five inches deep and the pebbles were rather coarse in size. The nymphs were taken by stirring up the pebbly bottom and catching the material that was loosened as it was carried downstream. Although a careful search of the creek was made, no other nymphs were found. A second examination of this same stream in May, 1954, did not produce any of these nymphs. The Ichawaynochaway is also a fairly large, deep stream in which the water is strongly tinted. The water was alkaline and snails were abundant. The last collection of *B. gibbera* was made in the Escambia River in October, 1954, along with *B. escambiensis*. The nymphs were found on the sloping bank in about three to twelve inches of water where there was a thin overlaying layer of small pebbles. By kicking up the bottom several nymphs of *B. escambiensis* and four of *B. gibbera* were collected on a screen held downstream. Only one of the latter was carried back alive to the laboratory where it lived for about a week without emerging.

BAETISCA OBESA (Say)

(Figs. 4, 9, 14, 19, 21)

The specimens that I am calling *B. obesa* resemble the forms described by Say (1839), Walsh (1863), Traver (1935), and Burks (1953) but differ in certain minor respects. Rather than again re-describe the species, I am simply mentioning the characteristics which deviate from those of the northern form. These differences, which I do not believe to be specific, appear to be confined to the adults; I can find no significant departures in the immature stage.

Male: The forelegs of the southern specimens are washed with a dusky coloration which is distinctly heavier at the femorotibial joint, and each tarsal joint is slightly shaded; the claws are brown. In the hindlegs, the femora, on the outer surface, have a faint, brownish band in the distal portion; the banding of the tarsal segments is quite distinct at the articulations and the claws are deep brown. The abdominal tergites are purplish brown with some variably-shaped, white blotches. Ventrally, the abdominal sternites are purplish brown laterally but very pale medially. There is an obsolescent pair of submedian brown spots on each of sternites 2-5; these are most distinct on sternites 2-4. Genitalia are very similar to those illustrated by Traver (Needham, Traver, Hsu, 1935, Fig. 148). Caudal filaments have the basal three segments distinctly annulate at the joints; distally the annulations become very faint and in the outer $\frac{4}{5}$ ths of the tails there is no banding. Wing length shorter than previously reported for this species, ranging from $7\frac{1}{2}$ to 8 mm.

Female: Legs of the female are rather heavily shaded with brown; tarsal annulations very distinct on all legs; the claws are dark. The first three segments of the caudal filaments are heavily ringed with brown; posteriorly the annulations become less prominent and finally disappear in the distal half. Wing length ranging from $7\frac{1}{2}$ to 9.3 mm.

Although *Baetisca obesa* has been known since the early part of the last century, almost nothing has been written of the ecology and habits of the nymphs. One of the few references is that of Walsh (1864) in which he says "The habits of this species are to frequent rapidly-running rivers, and to attach themselves in repose to the undersurfaces of submerged stones." This is a totally different sort of habitat from that in which my assistant and I have been able to collect the large number of nymphs we have taken. Previously nymphs have been scarce in collections. Whenever I have collected in moss attached to submerged tree trunks at stream banks, I have found the species to be common.

B. obesa has previously been reported from Georgia (Needham, Traver, Hsu, 1935) and from Florida (Berner, 1953). The nymphs almost invariably occur in very slow to almost stagnant water where they may be very common in moss or other vegetation. They have been found in some numbers in moss which is attached to the submerged trunks of cypress, willow and ash. In all of the streams from which these nymphs have been taken, the water has

been strongly colored and deep. The Withlacoochee River, which flows from southern Georgia into northern Florida and empties into the Suwannee River, has been the most prolific producer of this particular species; however, nymphs have been collected from other streams as well. The nymphs are usually found when moss is shaken vigorously into a strainer or taken out of the stream and put into a pan of water and shaken. The nymphs loosen their hold and swim about making it possible to collect them easily.

Nymphs were brought into the laboratory alive on January 28. From these a number of subimagoes emerged from early March to early April. Nymphs collected from the Withlachoochee River, four miles west of Valdosta, Georgia, produced subimagoes until the end of March, when emergence ceased and the remainder of the nymphs died attempting to emerge. Emergence differs from that of other species in that the immatures do not necessarily climb out of the water. That nymphs also to climb out of the water to emerge is evidenced by the fact that on April 13 at the Strong River, Rankin County, Mississippi, a single *B. obesa* skin was found on a bridge piling about ten inches above the water line.

The habits of this species differ entirely from those of any other species of *Baetisca* presently known in that they are not dwellers on the stream bottom and do not live on sand but cling to, and live deep within, vegetation masses. Other species occur where water flows swiftly; *B. obesa* lives in the quieter parts of the stream. This is indeed a departure from the previously described habits for this particular species, or any species in the genus *Baetisca*.

Locality Records: Florida: Hamilton County, Withlacoochee River, February 2, 1954; March 14, 1954; Madison County, Withlacoochee River, January 28, 1954. Georgia: Echols County, Alphaha River, February 2, 1954; Lowndes County, Withlacoochee River, March 13, 1954. Mississippi: Rankin County, Strong River, April 13, 1954.

BAETISCA ROGERSI Berner

(Figs. 1, 6, 11, 18, 22)

Since *B. rogersi* was described in 1940, it has been recorded on several other occasions, but it is still relatively rare in collections. The species is now known from northwest Florida, southeastern Alabama, and from Georgia, south of the Fall Line. The habits and ecology of *B. rogersi* were described earlier (Berner, 1950)

and will not be redetailed here. Locality records include only those previously unpublished.

Locality records: Florida: Liberty County, Sweetwater Creek, April 14, 1951 (adults reared on April 26, 30, and May 5); Gadsden County, Flat Creek, April 4, 1953, nymphs; Crooked Creek, March 20, 1954, nymphs. Georgia: Decatur County, Mosquito Creek at Bainbridge Road, March 28, 1954, nymphs; Peach County, Mossy Creek, April 10, 1954, nymphs.

BAETISCA CAROLINA Traver

(Figs. 2, 12, 17)

I have carefully examined the type specimens of *B. carolina* and paratypes of *B. thomsenae* Traver.³ These two species were differentiated by Traver (1937) solely on relative differences. I am unable to concur in her opinion that these are distinct species and am, therefore, considering *thomsenae* to be a synonym of *carolina*. It is my belief that the deviations in the characteristics used to distinguish these species are due only to local variations. All other species of *Baetisca* are clearly distinct morphologically in the nymphal stage, yet there are no such distinctions here. The degree of intensity of the coloration of the wings is well known to be a variable character in other species. Because the coloration has totally disappeared from the wings of the long-preserved specimens of both species, I was unable to utilize it in my study of these two; in spite of that, I do not feel that it is a valid characteristic for erecting a separate species for the Valle Crucis specimens. The other adult characters used by Traver, in my opinion, are not significant.

In addition to Traver's records of *B. carolina* from North Carolina, the species has been reported from Tennessee (as *B. thomsenae*, Wright and Berner, 1949). I have a single additional specimen also collected in North Carolina from Little River, Transylvania County, June 12, 1953, by M. J. Westfall.

KEY TO NYMPHS

1 Both dorsal and lateral spines present on mesonotum.

Frontal projection strongly developed (Fig. 4) *obesa*

³ I am indebted to Dr. Henry Dietrich, Cornell University, for the privilege of studying types and paratypes of *Baetisca carolina* and paratypes of *B. thomsenae*.

- 1' Lateral spines only on mesonotum. Frontal projection less well developed or absent (Fig. 2) 2
- 2 Genal spines present (Fig. 5) 3
- 2' Genal spines absent (Fig. 3) 4
- 3 Genal spines much shorter than head; upturned at tip. Lateral mesonotal spines moderately developed. Posterolateral abdominal spines incurved (Fig. 2) *carolina*
- 3' Genal spines as long as head; not upturned. Lateral mesonotal spines strongly developed. Posterolateral abdominal spines curve outwards (Fig. 5) *escambiensis*
- 4 Lateral mesonotal spines strongly developed, acuminate; anterior to these spines another lateral projection is present at margin of mesonotum; large spine-like tubercles on dorsal surface of mesonotal spines. Posterolateral angles of abdominal segments not incurved (Fig. 1) *rogersi*
- 4' Lateral mesonotal spines poorly developed; tips blunt; no lateral projection anterior to mesonotal spines. Posterolateral angles of abdominal segments incurved (Fig. 3).....*gibbera*

KEY TO ADULTS

- 1 Wings flushed with ruby. Penes with a lateral angulation near tip (Fig. 20) *escambiensis*
- 1' Wings colored only at base, or without color; penes without strong lateral angulation near tip (Figs. 21, 22) 2
- 2 Wings hyaline *obesa*
- 2' Wings colored basally 3
- 3 Basal third of forewing and basal three-fourths of hindwing reddish-brown; longitudinal veins amber. Abdominal tergites light reddish brown; sternites yellowish white. Coastal Plain species *rogersi*
- 3' Basal portion of wings orange brown; hindwing tinted throughout or only for half its width; longitudinal veins brown. Sternites light tan. Appalachian and Piedmont species *carolina*

REFERENCES

BERNER, LEWIS

1940. *Baetisca rogersi*, a new mayfly from northern Florida. Canad. Ent. 62:156-160. Pl. X.

1950. The mayflies of Florida. xii + 267 p. 88 figs., 24 pls., 19 maps. University of Florida Press, Gainesville.
1953. New mayfly records from Florida and a description of a new species. Fla. Ent. 36(4):145-149. 3 figs.
- BURKS, B. D.
1953. The mayflies, or Ephemeroptera, of Illinois. Ill. Nat. Hist. Surv. Bull., Vol. 26, Art. 1, 1-216, 395 figs.
- EATON, A. E.
1883-1888. A revisional monograph of recent Ephemeridae or mayflies. Linn. Soc. London Trans., Zool. Ser. 3: 1-352. 65 pls.
- McDUNNOUGH, J.
1932. New species of North American Ephemeroptera II. Canad. Ent. 209-215. 3 figs.
- NEAVE, FERRIS
1934. A contribution to the aquatic insect fauna of Lake Winnepeg. Internat. Rev. Hydrobiol. und Hydrogr. 31:157-170. 3 figs.
- NEEDHAM, J. G., JAY R. TRAVER, and YIN-CHI HSU
1935. The biology of mayflies. xvi + 759 p. 168 figs., 40 pls. Comstock Publishing Co., Ithaca.
- SAY, THOMAS
1839. Descriptions of new North American neuropterous insects and observations on some already described. Acad. Nat. Sci. Phila. Jour. 8:9-46.
- TRAVER, JAY R.
1931. The ephemerid genus *Baetisca*. N. Y. Ent. Soc. Jour. 39:45-67. Pls. 5-6.
1937. Notes on mayflies of the southeastern states (Ephemeroptera). Elisha Mitchell Sci. Soc. Jour. 53:27-86, Pl. 6.
- WALSH, B. D.
1864. On the pupa of the ephemerinuous genus *Baetisca* Walsh. Ent. Soc. Phila. Proc., 3:200-206. 1 fig.
- WRIGHT, MIKE, and LEWIS BERNER
1949. Notes on the mayflies of eastern Tennessee. Tenn. Acad. Sci. Jour. 24(4):287-298.

RESEARCH NOTES

THE GLOSSY IBISES OF LAKE ALICE.—Eastern glossy ibises, *Plegadis falcinellus*, are widely distributed in the Old World, but in the New World they have only occasionally been found nesting at a few scattered localities in Puerto Rico, Hispaniola, Cuba, Florida, Louisiana, Texas and South Carolina. In Florida there are four nesting colonies, at King's Bar, in Lake Okechobee; at Lake Washington, in the upper St. Johns River marshes; at Rabbit Island, in Lake Kissimmee; and at Lake Alice, Alachua County. In view of the rarity of these birds in the New World, these observations on the present status of the Lake Alice colony are presented.

The glossy ibises which nest at Lake Alice are apparently descended from the ones which nested at Orange Lake from 1909 to 1916 (Baynard, 1913, *Wilson Bull.*, 25: 103-117; Howell, 1932, *Florida Bird Life*, p. 116); a maximum of nine pairs nested at that locality. In 1937 these ibises had moved to Bivin's Arm, and at least 106 were present, but only 33 remained to nest (Russell, 1937, *Fla. Nat.*, 10: 80-82). In 1941, eight pairs nested there (Mills, 1941, *Fla. Nat.*, 14: 73-74). In 1947 only four glossy ibises were seen (Mills, 1947, *Fla. Nat.*, 20: 44). In 1948 the glossy ibises, along with the herons and white ibises, moved to Lake Alice to nest. Karraker (1953, *The Birds of Lake Alice*, M.S. Thesis, Univ. of Fla.) reported about 50 glossy ibises there in 1951, and about 30 in 1952. My own observations at Lake Alice cover the years 1953, 1954, and 1955.

In 1953 I first saw the glossy ibises on 14 March, when 13 arrived at the rookery with the evening flight of herons and ibises. Subsequent counts revealed that a maximum of 29 glossy ibises were roosting at the rookery in the spring and early summer. Several nests with young glossy ibises were found, but I do not believe that all of the birds nested.

In 1954 I first saw glossy ibises on 25 March, when ten were present. A maximum of 18 used the rookery up until 5 May. After that date there was a steady increase in number until a peak of 59 was reached on 10 July. Many of these birds were in adult plumage, so the increase was not due entirely to the fledgling of young birds, although a fairly large number of nests were found that summer. The last glossy ibises were seen on 26 August.

In 1955 I did not see any glossy ibises until 4 April, when only six roosted in the rookery. However, there was a sharp increase in numbers, and on 16 April 65 glossy ibises arrived at the rookery in the evening flight. Nesting had begun on 29 April. This colony, despite its small size and isolation from other colonies, seems to be maintaining itself.—Dale W. Rice, Department of Biology, University of Florida.

OBSERVATIONS ON THE ECOLOGY OF THE LOW HAMMOCKS OF SOUTHERN FLORIDA

TAYLOR R. ALEXANDER
University of Miami, Coral Gables

INTRODUCTION

In Florida the term "low hammock" is used to designate several types of hammock as far as floristic make-up is concerned. One characteristic seems to be common to all—their location in a low area that is usually wetter than surrounding areas. The low hammocks studied in this investigation are located in the extensive flat and low marl prairie that extends inland from the mangrove belt of subtropical Florida to higher soils of a different nature. This band of marl varies in width and is extensive in Dade County. Typical low hammocks of the type studied may be seen as scattered islands of trees on both sides of U. S. highway 1 south of Florida City and north of the Dade County line.

These hammocks and adjacent vegetation have been studied previously by others and plant lists of the common species have been made. Harper (1927) has sections on low hammocks, Cape Sable Hammocks, and the coast prairie. Each of these falls within the scope of the present study. According to the vegetation map prepared by Davis (1943), the low hammocks studied are "tree islands, bay tree forests," in the southern coast marsh prairies. Egler (1950) named the same hammocks "*Persea* tailed flat hammocks" and called the region the "southeast saline everglades."

The origin and ecology of these hammocks have been discussed by Egler (1950) and Davis (1940, 1943). Davis (1940) quotes Curtis as follows: "The mangrove thickets in the course of time build up a foundation for other species. It is altogether probable that the tree-covered 'islands' in the Everglades and Big Cypress were once mangrove thickets. . . . The mangroves will give place to species that require only brackish soil which, in turn, will be replaced by fresh water or inland forms of vegetation." This, in general, has been accepted by ecologists. As to the exact ecology, Davis (1943) wrote "there is probably some development from bay heads to low hammocks, and perhaps even a building up of

soils to higher almost dry hammocks. In fact the whole development of the sub-tropical hammock needs much more study."

It was to learn more of the succession of plants in this area that the investigation was undertaken. This report is the result of observations and measurements made on trips for the past decade. It gives supporting evidence as to the nature of succession involving these subtropical low hammocks of the marl prairie.

METHOD

After surveys of the area were made two hammocks were selected as representative. The first is about one-half mile west of U. S. 1, north of the Dade County line and just north of the mangrove belt. This hammock is typical for the area lying just inside the mangrove belt. It appears to be a young, immature hammock when compared to the second selection that was obviously older and located farther inland from the mangrove belt. The second hammock is located about two and a half miles west of the Cape Sable road about fifteen miles south of Paradise Key. The former will be referred to as hammock A and the latter as B.

Plant lists were made from data obtained by two methods—the line transect and quadrat techniques. The former was also used to establish successional aspects, particularly at the margins, and to measure changes in elevation of the soil surface. These changes between the elevation of the marl prairie and the interior of the hammock were determined along the line by use of a hand level, the marl prairie being used as "zero" elevation.

The soil profile was sampled with a soil auger. Samples were examined to determine their nature and were analyzed for pH with a Beckman pH meter. Soil moisture determinations were also made.

RESULTS

A line transect starting at the margin of hammock A and running fifty feet toward the center was used. Forty-five plants were listed and this large number is an indication of the dense growth of these tree islands. Twenty-three species were recorded.

Near the margin, *Rhizophora mangle*—red mangrove, *Conocarpus erecta*—buttonwood, *Myrica pumila*—wax myrtle, *Ilex cassine*—dahoon holly, *Tamala borbonia*—red bay, and *Swietenia mahagoni*—mahogany, were abundant.

In the lowest areas *Chrysobalanus Icaco*, the cocoa palm, pre-dominated. The marginal aspects of the hammock disappeared about twenty-five feet within the margin. Sawgrass, the marl prairie dominant, persisted up to this distance in spite of heavy shade. Toward the interior *Eugenia axillaris* and *Calypttranthes* were prominent as small trees under the canopy and were even more common as seedlings. Large trees of *Coccolobis uvifera*, the seagrape, were found in the older parts of the hammock.

A second line transect two hundred and fifty feet long was run from the center of the hammock out into the marl prairie to establish the relative differences in elevation of the soil level, and Table I gives a condensation of eight measurements. The hammock soil was highest near the center and gradually sloped to the lowest point just outside the abrupt hammock margin. This marginal low point was actually one to two inches lower than the surrounding marl prairie. At the highest point the soil level was seventeen inches above the outside prairie. Six inches increase in elevation was sufficient to allow hammock growth of considerable size near the margin.

TABLE I
Edaphic Conditions for Hammocks A & B

Station	Relative Elevation (Inches)		Percent Moisture		pH	
	A	B	A	B	A	B
Hammock center ---	17	28	191.0	90.4	7.9	6.3
Hammock margin ..	-1	-2	492.0	230.0	7.6	3.6
Outside prairie	0	0	106.0	81.3	8.5	7.9

Soil moisture near the hammock center and in the prairie was much lower than that in the low trough at the margin (Table I). The higher soil was composed of rather coarse organic material. The wet soil at the margin was fine textured and dark and contained a large amount of marl. The surface soil of the prairie was marl.

The soil of the low marginal trough was more acid than the organic soil near the center of the hammock or the surrounding marl (Table I).

Hammock B was sampled for edaphic conditions in the same manner as A, and results may be seen in Table I. When the data from these hammocks are compared, some similarity is evident. The two hammocks were sampled in different seasons and this accounts for the extreme differences in soil moisture. The level of the organic soil in hammock B was twenty-eight inches above the surrounding marl.

Hammock B was further analyzed by the quadrat technique, using six quadrats, five meters square. This number was used regardless of the fact that measurements by Cain's (1938) species-area curve method indicated that two such quadrats were a sufficient sample. Table II lists the species according to frequency and also gives their density. Shade tolerant seedlings of *Eugenia axillaris*, lancewood, spicewood, cabbage palm, and *Icacorea* were abundant.

TABLE II

Plant List of Hammock B Determined from Six, 5-Meter-Square Quadrats.

Species	Common Name	Average Density	Frequency
<i>Calyptanthes zuzygium</i>		4.66	100.0
<i>Eugenia axillaris</i>	White stopper	4.17	100.0
<i>Icacorea paniculata</i>	Marlberry	4.17	100.0
<i>Coccolobis laurifolia</i>	Pigeon Plum	1.33	83.3
<i>Swietenia mahagoni</i>	Mahogany	1.00	83.3
<i>Sabal palmetto</i>	Cabbage Palm	1.00	66.6
<i>Hippocratea volubilis</i>		Vine	66.6
<i>Parthenocissus quinquefolia</i>	Virginia Creeper	Vine	66.6
<i>Octotea catesbyana</i>	Lancewood	4.17	66.6
<i>Metopium toxiferum</i>	Poison wood	.66	50.0
<i>Dipholis salicifolia</i>	Bustic	1.16	50.0
<i>Smilax</i> spp.	Greenbrier	Vine	33.3
<i>Elaphrum simaruba</i>	Gumbo-limbo	.33	33.3
<i>Psychotria undata</i>	Wild coffee		33.3
<i>Rhus toxicodendron</i>	Poison ivy	Vine	33.3
<i>Quercus virginiana</i>	Live oak	.50	33.3
<i>Chrysophyllum oliviforme</i>	Satinleaf	.33	16.6
<i>Ficus aurea</i>	Strangler Fig	.33	16.6
<i>Muscadinia munsoniana</i>	Grape	Vine	16.6
<i>Rapanea guayanensis</i>	Myrsine		16.6
<i>Ampelopsis arborea</i>		Vine	16.6
<i>Paurotis wrightii</i>	Palm		16.6
<i>Roystonea regia</i>	Royal Palm		16.6
<i>Blechnum serrulatum</i>	Fern	High	16.6
<i>Nephrolepis exaltata</i>	Fern		16.6

DISCUSSION

The ecological data as presented here have need to be supplemented by observations that are not always subject to inclusion in formal tables. Complete examination of the two hammocks seemed to indicate a close successional relationship, each hammock apparently having developed along identical patterns. In hammock A several large, dead, relic red mangrove trees were found near the center (Figure 1). A study of nearby small islands of



Figure 1.—Prop roots of dead red mangrove relic in center of Hammock A.

trees in the prairie usually proved the existence of red mangrove as a pioneer tree. Hammock B was a much older hammock than A and red mangroves were found only as occasional small marginal trees.

Mahogany and red bay appear to be trees that may enter the succession very early. Mahogany is especially tolerant to brackish conditions. Buttonwood was also common in many large hammocks mostly as a relic tree. Live oak and mahogany apparently had played an important role in the development of hammock B. It should be noted that this hammock is near the inside edge of the marl prairie and close to the pineland ridge.

The mahogany trees of hammock A and adjacent hammocks were small and young compared to those of B. In the latter hammock one tree was found that measured twelve feet six inches in circumference four feet above the ground and its height was estimated at seventy feet. Live oaks of approximately the same size, together with the mahoganies, made up the upper canopy of this hammock. It should also be noted that both the royal and paurotis palms occur with the large mahoganies.

The presence of smaller and younger shade tolerant trees and seedlings indicate that both these hammocks are changing and becoming similar to the high tropical hammock usually located in the pineland, and these hammocks are dominated by a flora having definite affinities with the West Indian flora, as described by Philips (1940). Once the succession is started on the marl prairie, the build-up of the soil level by organic material accumulation seems to control the extent to which development will take place. In this connection the trough around these hammocks should be noted. Egler (1952) presented the hypothesis that "peat-deposition and marl-dissolution work simultaneously." This concept is most likely the answer to the occurrence of this trough. The acids that accumulate in the peat would certainly decompose the marl, that analyzes as high as ninety percent calcium carbonate. When dry, the soil in the trough is quite acid. However, it is usually very wet and undoubtedly plays an important part in controlling the frequent fires that otherwise would burn into these hammocks and kill the trees as well as destroy the organic mound. In the absence of fire these hammocks constantly expand and the inner edge of the trough fills with organic matter as the outer edge is extended by solution. This process of expansion seems to be a constant

pattern during this stage of the development of this type of low hammock.

SUMMARY

1. Two representative low hammocks were studied and analyzed for edaphic conditions and floristic composition to determine the nature of succession in these hammocks.

2. These hammocks exist on low mounds of accumulated organic material and appear to be protected from fire by a low wet trough that is a natural part of the development of these hammocks.

3. The importance of red mangrove, red bay, mahogany and live oak as pioneer plants in these low hammocks was established.

4. Data were obtained to show that these low hammocks can continue developing to the high, tropical hammock type.

LITERATURE CITED

CAIN, S. A.

1938. The Species-Area Curve. *Amer. Midl. Nat.* 19: 573-581.

DAVIS, J. H., JR.

1940. The Ecology and Geologic Role of Mangroves in Florida. Carnegie Institution of Washington. Publication No. 517, pp. 303-412.

1943. The Natural Features of Southern Florida. Geological Bulletin No. 25, State of Florida, Department of Conservation, Tallahassee.

EGLER, F. E.

1950. Southeast Saline Everglades Vegetation, Florida, and Its Management. *Vegetatio Acta Geobotanica*. Vol. III, Fasc. 4-5, pp. 213-265.

HARPER, R. M.

1927. Natural Resources of Southern Florida. From the 18th Annual Report of the Florida State Geological Survey.

PHILIPS, W. S.

1940. A Tropical Hammock on the Miami (Florida) Limestone. *Ecology* Vol. 21, No. 2, pp. 166-175.

A METHOD OF EXPOSING THE GASTRIC GLANDULAR MUCOSA OF MICE TO CARCINOGENIC AGENTS¹

MICHAEL KLEIN and MARY F. ARGUS²
Cancer Research Laboratory, University of Florida

Numerous experiments to induce gastric adenocarcinomas in experimental animals by oral administration of chemical carcinogens have been carried out but without success (Barrett, 1946; Hitchcock, 1952; Klein and Palmer, 1941; and Lorenz and Stewart, 1940). When methylcholanthrene was injected directly into the wall of the stomach, however, tumors of different types including a few gastric adenocarcinomas were observed (Stewart and Lorenz, 1942; and Stewart, Hare, Lorenz and Bennett, 1949). Attempts have also been made to induce adenocarcinoma of the stomach through irradiation damage. Moore, Smith, and Brackney (1953) attached balloons filled with phosphorus-32 against the gastric musoca in the antral region of the stomach of mice. The level of activity employed (56 to 200 μc) was too high, however, and over half of the animals died of radiation necrosis. Although squamous cell carcinomas were observed in some of the surviving animals, none originated in the gastric glandular mucosa.

In order to increase the prospects for obtaining gastric adenocarcinomas in mice, a method has been devised for attaching a pad containing a pellet of carcinogen or impregnated with sulfur-35 labeled barium sulfate directly to the gastric glandular musoca. The following procedure was used in preparing the pads containing a pellet of carcinogen: Two strips of 15 denier, 51 gauge, meshed nylon were impregnated and cemented together with Duco cement, and 4 mm. square pads were cut from the doubled nylon sheet thus formed. A nylon thread was attached to the corners of each pad prior to insertion into the stomach. Pellets of carcinogen 1.5 mm. in diameter were fixed to the center of each pad with celloidin taking care not to cover the surface of the pellet

¹ This investigation was supported in part by research grant C-1709 from the National Cancer Institute of the National Institutes of Health, Public Health Service and research grants DRIR-101 and 33B from the Damon Runyon Memorial Fund.

² With the technical assistance of Hilda M. Banks, Lois C. Sumner and Bert Theuer.

with the cementing substance. For the irradiation experiments, 4 mm. squares of the same nylon mesh, untreated, were used. Two squares were layered and were held together by nylon sutures attached to the corners. The pads were stretched over circular openings in a metal tray and 0.01 ml. of 0.1 M barium chloride was pipetted onto each pad. After one-half hour the pads were treated with 0.01 ml. of 0.1 M sulfuric acid-S³⁵ in the same manner. This precipitated 0.23 mg. of barium sulfate-S³⁵ on each pad. The microcuries of radioactivity per pad were determined by the specific activity of the sulfuric acid employed.

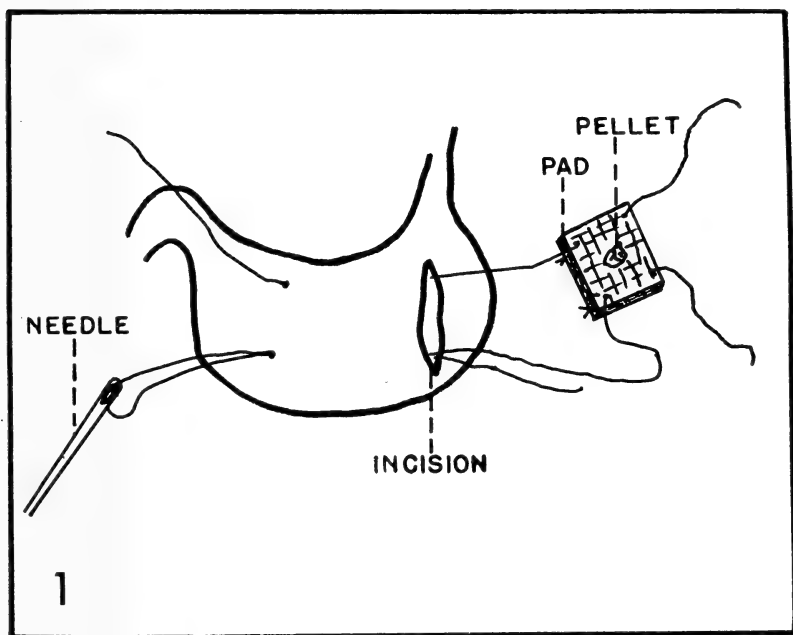

Figure 1.—Diagrammatic sketch, insertion of nylon pad into mouse's stomach.

At the time of operation, the ventral abdominal surface of each mouse was clipped free of hair and washed with 70 per cent alcohol. The stomach was exposed, draped, and kept moist with Ringer's solution. An incision was made in the abdominal wall of the fore-stomach approximately 3 mm. from the limiting ridge. Stomach contents were removed through the incision and the lumen rinsed with Ringer's. Needles were threaded with each of the sutures

on the pad, passed through the opening in the stomach to the antral region, and thrust through the anterior wall (Figure 1). The treated pad was drawn through the lumen and into contact with the glandular mucosa. The sutures were tied in pairs above the serosa. These same threads were then passed through a square of Ivalon surgical sponge³ (4x4x2 mm.) and the ends tied above the sponge (Figure 2). The forestomach incision was closed, the stomach



Figure 2.—Ventral view of mouse showing stomach exposed through a laparotomy sheet; a) ivalon sponge attached to serosa in antral region; b) pyloric end of stomach; c) spleen; d) greater curvature of stomach.

³ Obtained from Clay-Adams Co., Inc., 141 E. 25th St., N. Y. 10, N. Y.

returned to the abdominal cavity and the body wall and skin sutured. Operated animals were maintained on tap water alone for the next 24 hours and then given food *ad libitum*. Operative mortality has been observed to be less than 10 per cent under these conditions.

This method of applying a carcinogenic agent directly to the gastric mucosa has the following advantages: 1) a carcinogen may be placed against the mucosa in any desired region of the glandular stomach; 2) the tissue exposed is delimited and is readily located at autopsy; 3) the tissue surrounding each pad may be subjected to a continuous carcinogenic stimulus for a long time; and 4) since carcinogen remains in contact with glandular epithelium, it is expected that carcinoma induction would be favored.

To date, the following experiments have been completed employing this method. A total of 95 male mice from strain C3H received 3 to 4 mg. pellets of a preparation containing 1 per cent methylcholanthrene in cholesterol. Fifty-one additional mice received pellets of cholesterol alone. At autopsy, pellets of methylcholanthrene and of cholesterol were observed on the pads which had been attached to the glandular mucosa. Reduction in size of the original pellets was also noted. No tumors were observed in either group after as long as 367 days. Forty-eight mice from the same strain were treated with radioactive pads. Twenty-four received a dosage of $0.2 \mu\text{c}$ each while the remainder received $1.0 \mu\text{c}$ per mouse. Although mice were observed 289 days in the $0.2 \mu\text{c}$ group and 318 days in the $1.0 \mu\text{c}$ group, no radiation damage to the gastric mucosa was noted. The lowest dose of radioactivity employed by Moore, Smith, and Brackney (1953) in their experiments with the gastric mucosa of mice was $56 \mu\text{c}$ as compared to a maximum dose of $1 \mu\text{c}$ in the present experiment. Also, these authors employed phosphorus-32, an isotope which has a greater energy than sulfur-35. In the experiments of Stewart, Hare, Lorenz, and Bennett (1949), each mouse was injected intramurally with 0.3 mg. of methylcholanthrene while in the present investigation, each pellet contained 0.03 - 0.04 mg. of carcinogen. The absence of visible tumors with pellets of methylcholanthrene and with pads containing barium sulfate-S³⁵ indicates the need for increased dosages of these carcinogens.

LITERATURE CITED

BARRETT, M. K.

1946. Avenues of approach to the gastric-cancer problem. *J. Nat. Cancer Inst.*, 7: 127-157.

HITCHCOCK, C. R.

1952. Failure of eugenol and heat to potentiate gastric tumor induction by 20-methylcholanthrene in mice. *J. Nat. Cancer Inst.*, 12: 723-733.

KLEIN, A. J., and W. L. PALMER

1941. Experimental gastric carcinoma: A critical review with comments on the criteria of induced malignancy. *J. Nat. Cancer Inst.*, 1: 559-584.

LORENZ, E., and H. L. STEWART

1940. Intestinal carcinoma and other lesions in mice following oral administration of 1,2,5,6-dibenzanthracene and 20-methylcholanthrene. *J. Nat. Cancer Inst.*, 1: 17-40.

MOORE, G. E., G. A. SMITH and E. L. BRACKNEY

1953. The use of intragastric balloons containing P³² in an attempt to produce adenocarcinoma of the stomach in the mouse. *J. Nat. Cancer Inst.*, 13: 963-977.

STEWART, H. L., and E. LORENZ

1942. Adenocarcinoma of the pyloric stomach and other gastric neoplasms in mice induced with carcinogenic hydrocarbons. *J. Nat. Cancer Inst.*, 3: 175-189.

STEWART, H. L., W. V. HARE, E. LORENZ and J. G. BENNETT

1949. Adenocarcinoma and other lesions of the glandular stomach of mice, following intramural injection of 20-methylcholanthrene. *J. Nat. Cancer Inst.*, 10: 359-373.

MONOGENETIC TREMATODES OF GULF OF MEXICO
FISHES. PART III.

THE SUPERFAMILY GYRODACTYLOIDEA
(Continued)¹

WILLIAM J. HARGIS, JR.
The Citadel, Charleston, South Carolina

This paper is the third of the present series treating the monogenetic trematodes of the Gulf of Mexico. It deals specifically with several species belonging to the subfamilies Tetraonchinae Monticelli, 1903, and Diplectaninae Monticelli, 1903, *emend.*, and is a continuation of the data concerning members of the superfamily Gyrodactyloidea Johnston and Tiegs, 1922, obtained during a recently concluded study of these ectoparasites. The scope organization and purpose are the same as for preceding installments.

All measurements were made using an ocular micrometer and are cited in millimeters. In the cases of curved structures measurements are of lines subtending the greatest arcs of those structures. In the descriptions given below the mean is given first, followed by the minima and maxima in parentheses. The number of measurements used to derive the mean is usually the same as the number of individuals measured; otherwise the actual number employed appears in parentheses before the measurements. All drawings were made with the aid of the camera lucida.

PSEUDOHALIO TREMA MUGILINUS n. sp.

(Figures 44-48)

Host: *Mugil caphalus* Linn., Striped Mullet, a benthic-littoral euryhaline marine mugilid.

Location: Gills.

Locality: Alligator Harbor, Franklin Co., Florida.

¹ Contribution from the Biological Laboratories of the Citadel and the Zoology Dept. and Oceanographic Inst. of Florida State University, Tallahassee.

Acknowledgments and dedications of the present installment are largely the same as for preceding ones. In addition, however, the writer wishes to thank Drs. M. H. Knisely and C. A. Higginbotham of the Dept. of Anatomy, Medical College of South Carolina, Charleston, for making optical equipment and working space available for parts of this study.

This research was partially financed by the A.A.A.S.—Florida Academy of Science grant in aid.

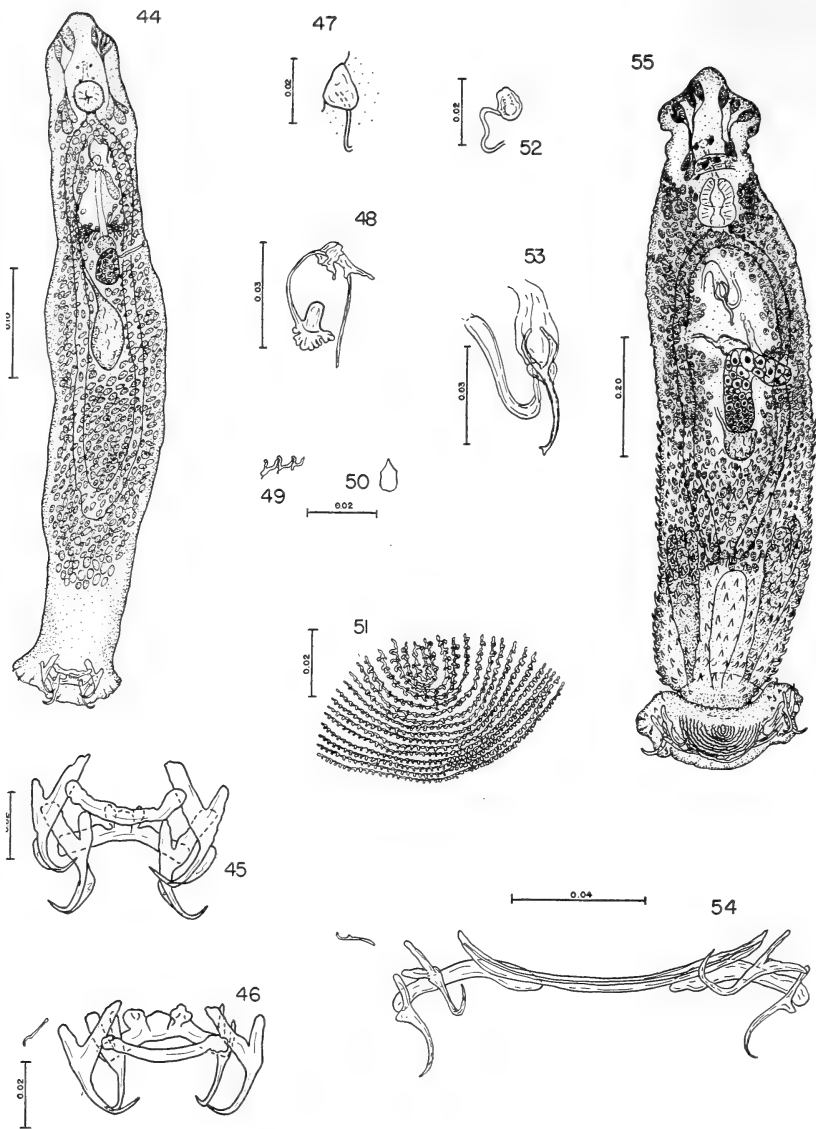

Pseudohaliotrema mugilinus n. sp.

44. Whole mount, dorsal view.
 45. Haptor complex, dorsal view.
 46. Haptor complex, dorsal view.
 47. Vagina.
 48. Cirrus complex.

Diplectanum bilobatus n. sp.

49. Squamodisk sclerites.
 50. Scale-like body spines.
 51. Squamodisk.
 52. Vagina.
 53. Cirrus complex.
 54. Haptor complex.
 55. Whole mount, dorsal view.

Number studied: 135.

Number measured: 5.

Holotype: USNM Helm. Coll. No. 49342.

Paratype: USNM Helm. Coll. No. 49343.

Description: Body somewhat cylindrical, 0.633 (0.605-0.656) long by 0.113 (0.102-0.133) wide, anterior end angular. Cuticle thin and smooth. Prohaptor of 2 to 3 pairs of antero-lateral head organs connected by ducts to cephalic glands lying lateral and posterior to the pharynx. Opisthaptor a slightly flared disk about 0.084 (0.076-0.096) in diameter, opening posteriorly and armed with 2 pairs of centrally located anchors, 2 bars and 14 hooks. Both anchor pairs similar in shape, with long superficial roots, short deep roots, recurved tips and delicate wing-like expansions along shafts; ventral anchors 0.034 (0.032-0.036) long by (4) 0.003 (0.003-0.004) wide at base; dorsal anchors 0.034 (0.028-0.038) long by 0.003 (0.003-0.005) wide at base. Bars slightly dissimilar in size, apparently not articulated with one another; ventral bar broadly V-shaped with prominent anterior sculpturing, 0.037 (0.031-0.043) long by 0.009 (0.008-0.009) wide, dorsal bar broadly V-shaped, smooth, with expanded ends, 0.035 (0.032-0.037) long by 0.005 (0.004-0.005) wide. Hooks delicate, 0.010 (0.009-0.010) long, with thin shafts and recurved tips. Mouth midventral at level of anterior eyespots; narrow buccal canal. Pharynx ovoid, 0.036 (0.025-0.067) long by 0.029 (0.023-0.034) wide, muscular; esophagus very short. Gut bifurcated, crura unramified, confluent posteriorly. Testis saccate (4) 0.058 (0.050-0.066) long by (4) 0.030 (0.023-0.038) wide, equatorial; vas deferens reaching seminal vesicle via left side. Seminal vesicle variable in outline, postero-sinistral to cirrus. Cirrus complex consisting of a dome-like cirrus bulb, cirrus and possibly an accessory piece. Cirrus bulb at base of cirrus; cirrus a long, thin, recurved, hollow tube, 0.033 (0.029-0.038) long by 0.001 wide, surrounded at the curve by an irregular cuticularized mass that may be an accessory piece and not just a cirrus ornamentation. Prostate reservoir postero-dextral to cirrus. Genital pore common, ventral to gut bifurcation. Ovary saccate, pretesticular, slightly dextral to midline; oviduct short. Ootype short; uterus runs anterior in the midventral line to genital pore. Vaginal pore on right margin at ovarian level, surrounded by a cuticularized external plate; vaginal duct cuticularized, opening into spherical seminal receptacle. Seminal receptacle apparently opens into oviduct immediately anterior to ovary. Mehlis' gland around ootype just anterior to seminal receptacle. Vitellaria follicular, near intestinal crura, extending from level just posterior to pharynx slightly past posterior confluence of gut; transverse vitelloducts joining oviduct anterior to seminal receptacle. Egg not observed. Two pairs of angularly situated eyespots antero-dorsal to pharynx.

Discussion: *Pseudohaliotrema mugilinus* n. sp. differs from all others in the genus in the following respects: (1) median ornamentation of the ventral bar, (2) long, thin shape of the cirrus, (3) shape of anchor roots, (4) host.

Haploleidus vanbenedenia (Parona and Perugia, 1890) Palombi, 1949 (= *Ancyrocephalus venbenedeni*) from the gills of *Mugil auratus* Risso from Genoa is apparently very similar to the present species, but differs in the following respects: (1) ornamentation of the ventral bar, (2) cirrus ornamentation, (3) larger size of anchor pairs, (4) host.

As is mentioned in Part I of this series, the characters used to separate the genus *Haploleidus* from other Tetraonchinae are not strong. In addition, the original description and redescrptions of *H. vanbenedeni* are lacking in detail. Therefore, *H. vanbenedeni* needs restudy based on fresh material as does the genus.

Genus TETRANCISTRUM Goto and Kikuchi, 1917

This tetraonchid genus is another which can be easily confused with *Ancyrocephalus* Creplin, 1839 and badly needs rediagnosis. A cursory study of the figures and description of the type species, *Tetrancistrum sigani* Goto and Kikuchi, 1917, indicates that the following characters are present: (1) crura of gut laterally ramified, (2) eyespots present, (3) vas deferens entirely between the intestinal crura medially, (4) Mehlis' gland elements often extend lateral to crura. Some of these features are undoubtedly taxonomically significant. Neither Price (1937) nor Sproston (1946) included these characters in their diagnoses of *Tetrancistrum*. In addition, Price (1937) placed *Tetrancistrum longiphallus* (MacCallum, 1915) Price, 1937 in this genus even though it lacks the first and last of the above characters. Due to the uncertain taxonomic condition of the entire subfamily a reassignment of this species cannot now be made; however, future rediagnosis of the genus may necessitate such action.

T. lutiani Tubangui, 1931, may also have to be reassigned because it, too, apparently does not have the ramified intestinal crura and lateral Mehlis' gland elements mentioned above.

Yamaguti (1953) is the first recent author to recognize the lateral rami of the intestinal crura as being diagnostically significant in these tetraonchids. Because he has actually collected and reported the type species several times it must be assumed that he has verified the presence of these rami.

Tetrancistrum longiphallus (MacCallum, 1915) Price, 1937

Synonyms: *Ancyrocephalus chaetodipteri* Pearse, 1949, n. syn.; *Ancyrocephalus longiphallus* (MacCallum, 1915) Johnston and Tiegs, 1922 and *Diplectanum longiphallus* MacCallum, 1915.

Host: *Chaetodipterus faber* (Broussonet) Spade Fish, a nerito-pelagic marine ephippid.

Location: Gills.

Locality: Alligator Harbor, Florida.

Previously reported host and localities: *C. faber* from Beaufort, N. C.

(Pearse, 1949) and New York Aquarium (MacCallum, 1915).

Number studied: 217.

A study of the type slides, Pearse's USNM Helm. Coll. slide No. 36959 and MacCallum's USNM Helm. Coll. slide No. 35702, and comparison of these with the specimens in the present collection show that the forms described by Pearse (1949) as *Ancyrocephalus chaetodipteri* and MacCallum (1915) as *Tetrancistrum longiphallus* are the same species and their names synonymous. Also, the specimens in the present collection, while a little different, are actually conspecific with them. Some of the variations between the species in the present collection and those in the collections of others are: (1) some slight differences in the shape of the haptor bar ends, (2) anchors vary slightly in shape, etc. Since these characters are actually variable within the collection they are probably not taxonomically significant. MacCallum (1915) described the gut as not confluent posteriorly, but it is confluent in the specimens of the present collection. Fourteen marginal hooks are present. Peduncle glands were also observed in many specimens. In addition, eyespots are present, consisting of many small, melanistic granules scattered in the antero-dorsal region. These were also found in the type slides of MacCallum and Pearse. Similar dots can be observed in the original figures of Goto and Kikuchi (1917) for the type species, *T. sigani*. These dots are labelled "brain" but they are probably photo-receptive granules.

T. longiphallus may not even belong to the genus in which it is presently placed, but its removal must await future taxonomic work.

Subfamily Diplectaninae Monticelli, 1903, *diag. emend.*

Diagnosis: Dactylogyridae in which the posterior half of the body is generally covered with anteriorly directed cuticular spines. Head organs and cephalic glands present. Haptor or peduncles bear plaques,² either dorsal and ventral squamodisks alone or dor-

²The word *Plaque* is proposed as a new term (though used by Sproston, 1946, in an informal way) to apply to the complex holdfasts that are superficially located in the posterior body region and probably derived from the cuticular layers of the organisms possessing them. The different types of Plaques are: *Lateral plaques*—lateral expansions consisting either of many spines or a simple raised area of the cuticle, *Dorsal and Ventral Plaques*—subrectangular groups of hook-like spines on the peduncle, often overlapping the anterior margin of opisthaptor; and *Squamodisks*—oval or circular structures composed of groups of concentrically arranged rows of small spines or lamellate rows of larger, curved spines.

sal, ventral and lateral plaques or, exceptionally, lateral palques only (*Rhabdosynochus*). Two pairs of anchors, three or four bars, and 14 hooks present. Cirrus cuticularized. Genital pore common. Vagina present. Ovary often looped around right intestinal crus.

Type genus: *Diplectanum* Diesing, 1858

The above emendation is made in the subfamily diagnosis to permit the inclusion of *Rhabdosynochus* Mizelle and Blatz, 1941, *emend.* which is definitely a diplectanid genus, and *Rhamnocercus* Monaco, Wood and Mizelle, 1954, *emend.*, whose affinities are thought to be too closely diplectanid to support its being used as the basis of a new tetraonchid subfamily (Rhamnocercinae Monaco, Wood and Mizelle, 1954) as was done by the original authors.

The precise status of the genus *Neodiplectanum* Mizelle and Blatz, 1941, must be established by future studies because recent work indicates that it is not very different from *Diplectanum*. It now appears that the two dorsal bars of *Neodiplectanum* are probably similar to those of other diplectanids.

It is possible that the two dorsal bars of Diplectaninae are homologous to the single dorsal bars of the Tetraonchinae. There is actually a member of the latter subfamily, *Hematopeduncularia bagre* Hargis, in press, whose dorsal bar appears to have developed in two parts. In addition, the two lateral bars of *Murraytrema* Price, 1937, if they actually are homologous to the dorsal bars, may represent an intermediate stage between the medially placed two bars of some tetraonchids and laterally placed bars of diplectanids.

Genus DIPLECTANUM Diesing, 1856

Diplectanum should be restudied critically because there is a strong possibility that several natural groups that deserve generic status are included therein.

DIPLECTANUM BILOBATUS n. sp.

(Figures 49-55)

Host: *Cynoscion nebulosus* (Cuvier and Valenciennes) Spotted Squeteague, a benthic-littoral marine sciaenid.

Location: Gills.

Locality: Alligator Harbor, Franklin Co., Florida and Grand Isle, Jefferson Parish, La.

Number studied: 47.

Number measured: 5.

Holotype: USNM Helm. Coll. No. 49344.

Description: Body elongate, 0.502 (0.388-0.573) long by 0.124 (0.096-0.140) wide, sides nearly parallel, narrowed at level of the eyespots and immediately anterior to opisthaptor, anterior end angularly spatulate. Skin apparently thin and nearly smooth anteriorly, bearing numerous anteriorly projecting scale-like spines around posterior part of body behind level of ovary. Prohaptor of 3-4 pairs of head organs connected by ducts to posterior cephalic glands. Opisthaptor wider than long, 0.104 (0.070-0.153) long by 0.105 (0.070-0.146) wide, somewhat lobulate, armed with dorsal and ventral squamodisks, 2 pairs of anchors, 3 bars, at least 6 pairs of hooks and 2 laterally placed groups of scale-like spines which are near the anchor roots. Anchor pairs similar in size, dissimilar in shape, each member of a pair on opposite lobes of haptor. Ventral anchors 0.034 (0.030-0.041) long by 0.003 (0.003-0.004) wide at base, superficial roots long and thin, set at an unusual angle, deep roots stouter and slightly longer than that of dorsal anchor, shaft short, somewhat angularly recurving tip; dorsal anchors 0.033 (0.030-0.035) long by (4) 0.003 wide at base, superficial roots vestigial, deep roots elongate. Ventral bar very long and thin, slightly curved, 0.074 (0.030-0.094) long by 0.004 (0.003-0.005) wide, with longitudinal furrow; dorsal bars narrower laterally than medially, 0.038 (0.034-0.042) long by 0.007 (0.005-0.010) wide, situated laterally on haptor lobes, articulating with dorsal anchors and attached medially by strong muscular elements. Hooks, only 6 pairs seen, marginal on lateral lobes, 0.009 (0.008-0.009) long, with narrow, delicately curved shafts and sickle-shaped terminations. Squamodisks slightly dissimilar in size, ventral wider than dorsal and often more anteriorly placed, composed of concentrically arranged, chain-like rows of very small somewhat Y-shaped cuticularized pieces; ventral squamodisk 0.070 (0.047-0.081) long by 0.051 (0.037-0.063) wide; dorsal squamodisk 0.071 (0.061-0.077) long by 0.042 (0.032-0.054) wide. Two lateral, saccate peduncle glands filled with cells, and one bladder-like saccate medial structure located in the peduncle, all three structures apparently opening on or near opisthaptor. Mouth ventral to anterior eyespots; buccal canal narrow. Pharynx slightly bilobed in all specimens studied, weakly piriform, 0.038 (0.034-0.043) long by 0.031 (0.023-0.036) wide. Esophagus extremely short. Gut bifurcated, crura unramified and apparently not confluent posteriorly. Testis somewhat irregular in shape, most often ovoid, 0.025 (0.022-0.034) long by 0.023 (0.020-0.027) wide, slightly post-equatorial, in midline; vas deferens apparently passing anteriorly on the left side, appearing to form a seminal vesicle at base of cirrus. Cirrus composed of an unusual forked base, lying within a fusiform chamber, and a hollow, tubular portion with a slightly flared tip, 0.026 (0.022-0.035) long by 0.002 (0.001-0.002) wide. Unidentifiable, seemingly hollow, J-shaped cuticularized structure running into the cirrus dextrally. Genital pore common, slightly dextral to the midventral line near cirrus tip. Ovary tubular, pretesticular, equatorial, looped over the right intestinal crus; wide oviduct joined by vitelloglands. Uterus extending directly to genital pore. Vaginal pore to left of the midventral line at about one-third level of body, cuticularized external

plate situated around vaginal pore; vaginal duct also cuticularized, widened medially to join seminal receptacle which enters oviduct from left. Mehlis' gland not observed. Vitellaria follicular, near intestinal crura, extending from anterior level of pharynx and terminating shortly posterior to intestinal junction; transverse vitelloglands converging immediately anterior to ovary. No eggs observed. "Brain" dorsal to buccal tube; 4 eyespots angularly situated antero-dorsally to pharynx near "brain."

Discussion: *Diplectanum bilobatus* n. sp. is apparently most closely related to *D. girellae* (Johnston and Tiegs, 1922) Price, 1937 from which it differs in the following respects: (1) bifurcation of the cirrus base, (2) ventral anchors with only one prominent root, (3) shape of bars slightly different, (4) host.

The ovary of this species loops around the right crus of the gut, a character which, although not often previously reported, may be significant. Yamaguti (1953) describes the ovary as looping around the gut in one species of *Pseudolamellodiscus* Yamaguti, 1953 and in three species of *Lamellodiscus* Johnston and Tiegs, 1922. Since this character is present in all the diplectanids in the present collection a restudy of the previously described forms will probably confirm it in many of them. This feature is present in many capsulids and may be an indication of some phylogenetic relationship between the two groups.

Rhamnocercus Monaco, Wood and Mizelle, 1954, *emend.*

Diagnosis: Diplectaninae. Body elongate, flattened dorso-ventrally, opisthaptor bilobed. Posterior portion of cuticle spinous. Head organs present. Peduncle glands and medial bladder-like structure present. Lateral plaques, each consisting of a row of hook-like spines and dorsal and ventral plaques, consisting of two chevron-like rows of hook-like spines, present. Dorsal and ventral groups of strong, anteriorly curved spines situated mid-terminally on the opisthaptor. Additional hook-like spines and shorter, often clumped, spines also on opisthaptor. One ventral and two dorsal bars present. Two dissimilar anchor pairs and 14 marginal hooks. Cirrus elongate, cuticularized, spiralled or straight. Ovary pretesticular, looped around right intestinal crus. Vaginal pore ventral or lateral.

Type species: *Rhamnocercus rhamnocercus* Monaco, Wood and Mizelle, 1954.

Synonym: *Pedunculospina* Hargis, 1954.

Rhamnocercus differs from other diplectanids in the following characters: (1) dorsal and ventral plaques and not squamodisks present, (2) spinous lateral plaques on peduncle, (3) additional spines grouped on haptor. Apparently this genus occupies a somewhat isolated position in the subfamily because it is very different from any previously described. The above rediagnosis is given in order to include additional data on the genus obtained from studies of the paratypes (USNM Helm. Coll. No. 49426) of *Rhamnocercus rhamnocercus*, the type species, and *Rhamnocercus bairdiella*

n. sp. The name *Pedunculospina* Hargis, 1954 is listed as a synonym of *Rhamnocercus* because it appeared in an abstract, Hargis (1954), published several days after publication of the latter name by Monaco, Wood and Mizelle (1954).

Rhamnocercus rhamnocercus Monaco, Wood and Mizelle, 1954

This species occurs, according to the original authors, on the gills of the marine sciaenid, *Umbrina roncadora*, in the Pacific Ocean off California. It is interesting and probably phylogenetically significant that *Bairdiella chrysura*, the host of the new rhamnocercid described below, is also a member of the piscine family Sciaenidae.

A study of two paratype specimens on the above listed slides indicates that the original authors were probably mistaken concerning the dorso-ventral orientation of the opisthaptor. Even though the paratypes were twisted several times, careful check reveals that the long, single, longitudinally-furrowed bar is actually dorsal and not ventral. Also, the anchors labelled as ventral in the paper by Monaco, Wood and Mizelle (1954) are really dorsal and vice versa. This clarification means that the bars and anchors are truly diplectanid in location and general shape and not different. Although difficult to ascertain microscopically in the paratypes, it appears that lateral plaques, each composed of a row of anteriorly-directed spines, are present on each side of the peduncle.

As a direct result of microscopic studies of *R. rhamnocercus* and the new species detailed below it is herein contended that the differences employed by Monaco, Wood and Mizelle (1954) as a basis for their subfamily Rhamnocercinae are insufficient to support such action. The reasons underlying this contention are: (1) The dorsal and ventral plaques are probably homologous to the squamodisks of other diplectanids. (The supposed perenchymatous origin of these and other spinous parts which was mentioned by the original authors is much too uncertain to be a taxonomically reliable character.) (2) The detailed similarity of the haptor bars, anchors, hooks, lateral plaques, body shape and the arrangement of internal organs to the same structures in other diplectanids are not counterbalanced by sufficient morphological differences. The existing differences mentioned immediately above in this discussion are herein adjudged of generic but not subfamilial significance; therefore, the subfamily Rhamnocercinae Monaco, Wood

and Mizelle, 1954 is rejected and its type genus *Rhamnocercus* is considered a subordinate, albeit somewhat aberrant, group of the subfamily Diplectaninae.

RHAMNOCERCUS BAIRDIELLA n. sp.

(Figures 56-60)

Host: *Bairdiella chrysura* (Lacépède), Silver Perch, a benthic-littoral marine sciaenid.

Location: Gills.

Locality: Alligator Harbor, Franklin Co., Florida.

Number studied: 158.

Number measured: 5.

Holotype: USNM Helm. Coll. No. 49345.

Paratype: USNM Helm. Coll. No. 49346.

Description: Very small diplectanid, body weakly fusiform, 0.350 (0.298-0.401) long by 0.056 (0.040-0.069) wide, angular anteriorly, narrowed posteriorly to join opisthaptor. Cuticle thin and smooth anteriorly, projected into numerous anteriorly directed spines encircling body from level of ovary to opisthaptor. Prohaptor of 3 pairs of antero-lateral head organs connected by ducts to posterior cephalic glands that are lateral to the pharynx. Opisthaptor bilobed, 0.110 (0.097-0.131) long, armed with 2 pairs of laterally placed anchors, 3 bars, 4 groups of short spines and 14 marginal hooks. Anchors delicate, subequal, dissimilar in shape; ventral anchors, 0.040 (0.036-0.042) long by 0.003 wide, superficial roots delicate, at right angles to main axis anchor, deep roots longer, shafts long and nearly straight, tips slightly recurved; dorsal anchors 0.040 (0.038-0.041) long by (4) 0.001 wide at base, superficial roots shorter than those of ventral anchor, deep roots long. Ventral bar elongate, weakly fusiform, 0.070 (0.061-0.078) long by 0.005 (0.004-0.005) wide, longitudinally furrowed; dorsal bars club-shaped, curved, 0.041 (0.035-0.046) long by 0.005 (0.004-0.005) wide, nearly meeting in midline, articulating with dorsal anchors laterally. Fourteen hooks present, about 0.009 long, 6 pairs on margins of lateral lobes and 1 pair near the mesial ends of dorsal bars. Median plaques located mostly on the peduncle, but extending slightly onto the opisthaptor posteriorly; ventral plaque, (3) 0.057 (0.030-0.081) long by (3) 0.031 (0.028-0.034) wide, composed of 8 to 9 spines, (3) 0.021 (0.018-0.024) long; dorsal plaque, (3) 0.065 (0.036-0.085) long by (3) 0.030 (0.024-0.032) wide, composed of 9 pairs of hook-like spines, (3) 0.020 (0.019-0.022) long, in two rows. Two lateral plaques consisting of 7 to 8 laterally placed spines, spines about (1) 0.015 long. Two saccate peduncle glands situated laterally and a median, elongate, bladder-like structure located in the peduncle; glands and bladder-like structure opening on or near the opisthaptor. Mouth midventral, at level of anterior eyespots; buccal canal leading to pharynx. Pharynx piriform, (3) 0.017 (0.015-0.020) long by 0.015 (0.014-0.018) wide; esophagus absent. Gut bifurcated, crura unramified, apparently confluent posteriorly. Testis saccate, between intestinal crura in posterior half of body, 0.044 (0.041-0.054) long by 0.028

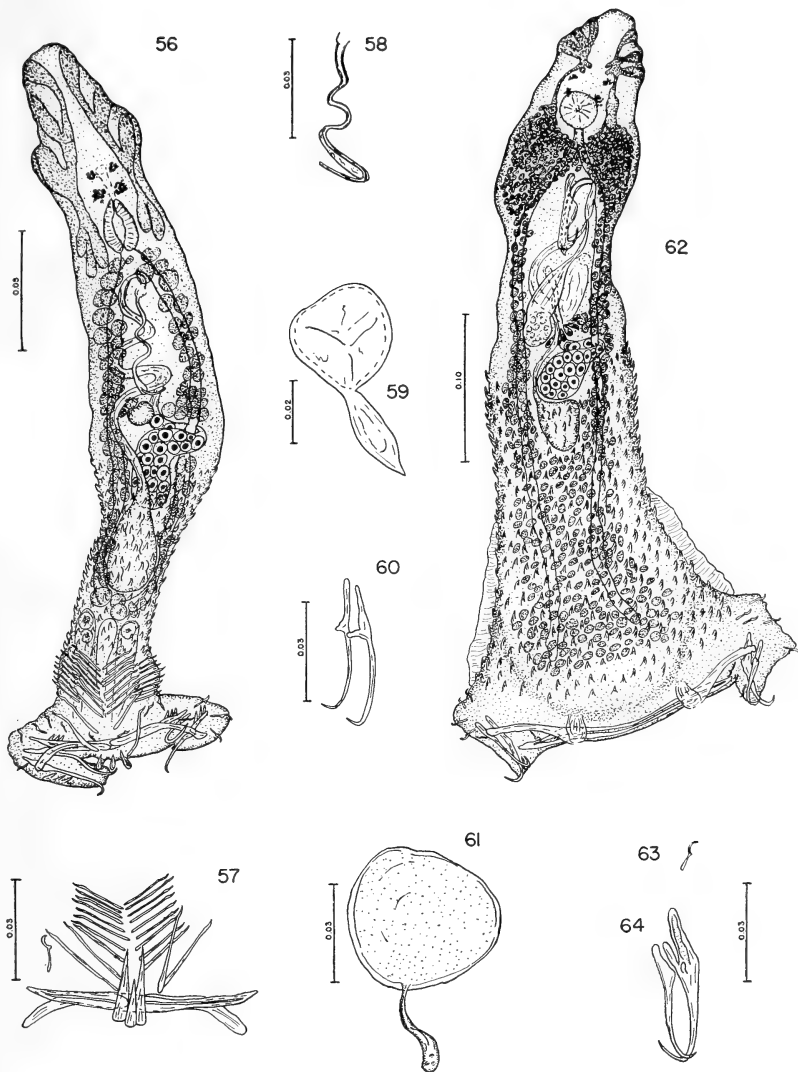

Rhamnocercus bairdiella n. sp.

56. Whole mount, dorsal view.
 57. Ventral plaque, with haptor bars, hooks and spines.
 58. Cirrus.
 59. Egg, *in utero*.
 60. Anchors, ventral anchor uppermost.

Rhabdosynochus rhabdosynochus

61. Egg, *in utero*.
 62. Whole mount, dorsal view.
 63. Hook.
 64. Anchors, ventral anchor largest.

(0.022-0.038) wide; vas deferens prominent. Cirrus complex consisting of a cirrus and possibly an accessory piece. Cirrus, 0.045 (0.032-0.054) long by 0.001 wide, narrow and sinuous; long, thin, spatulate structure curved around cirrus distally may be an accessory piece. Genital pore common, midventral, slightly preequatorial. Ovary elongate, pretesticular, looped over right intestinal crus; oviduct short, joined by vitelloblasts immediately anterior to ovary. Ootype short; uterus short, wide, extending a short distance obliquely and anteriorly toward the midline at level of transverse vitelloblasts; vaginal pore slightly lateral, vaginal tube wide, opening into spherical seminal receptacle; which apparently opens into the oviduct immediately anterior to ovary. Mehlis' gland not seen. Vitellaria follicular, near intestinal crura, extending from pharynx posteriorly to the peduncle; transverse vitelloblasts converging immediately anterior to ovary. Egg *in utero* apparently spherical, with a stout, fusiform filament at one end. Four eyespots dorsal to buccal canal.

Discussion: *Rhamnocercus bairdiella* n. sp. is definitely rhamnocercid in nature but differs from the type species, *R. rhamnocercus*, in the following characters: (1) body and all hard parts much smaller, (2) shape of anchors, (3) cirrus spiralled and not straight, (4) shape and number of the spines of the dorsal, ventral and lateral plaques, (5) host.

As mentioned above, it is interesting and perhaps significant that both of the known species of the aberrant genus *Rhamnocercus* occur on hosts of two genera which belong to the same family, Sciaenidae.

Genus *Rhabdosynochus* Mizelle and Blatz, 1941 *emend.*

Synonym: *Rhabdosynochus* Mizelle and Blatz, 1941. (Definitely a misprint as Sproston, 1946, suggested.)

Diagnosis: Diplectaninae. Body elongate, flattened dorso-ventrally, widened posteriorly. Posterior body spines present. Prohaptor of three pairs of head organs connected by ducts to posterior cephalic glands. Opisthaptor bearing two pairs of dissimilar anchors and three separate bars, two of which are dorsal, and 14 marginal hooks. Lateral plaques present. Cirrus and accessory piece cuticularized. Ovary looped around intestinal crus. Vaginal pore apparently ventral. Intestinal crura not confluent posteriorly.

Type species *Rhabdosynochus rhabdosynochus* Mizelle and Blatz, 1941.

The above emendation is made necessary by the redescription of the type species which demonstrates clearly the diplectanid affinities of the genus (see below). The genus *Rhabdosynochus* is regarded as valid because it is different from all other genera of Diplectaninae in possessing only the clear, lateral plaques and having neither squamodisks nor dorsal and ventral plaques.

Rhabdosynochus rhabdosynochus Mizelle and Blatz, 1941

(Figures 61-64)

Host: *Centropomus undecimalis* (Bloch), Snook, a euryhaline, littoral centropomid.

Location: Gills.

Locality: Tampa Bay, Florida.

Previously reported host and locality: *Centropomus undecimalis*, Myakka River, East Sarasota, Florida.

Number studied: 177.

Number measured: 1.

Holotype: USNM Helm. Coll. No. 49347.

Redescription: Body elongate, 0.503 long by 0.185 wide anteriorly, anterior end angular, posterior end extremely wide and spatulate. Cuticles fairly thick, smooth anteriorly, with numerous anteriorly directed spines in posterior portion. Prohaptor 3 pairs of head organs connected by ducts to posterior cephalic glands. Opisthaptor wide, spatulate, bilobed, 0.049 long by 0.237 wide, armed with 2 pairs of anchors, 3 bars, and 14 marginal hooks laterally placed. Anchors dissimilar in size and shape, laterally placed on haptor lobes; ventral anchors larger, 0.047 long by 0.004 wide at base, superficial roots short, finger-like, deep roots longer and broader, extra protuberance often seen on mesial surface; dorsal anchors shorter, 0.028 long by 0.003 wide at base, superficial roots apparently vestigial, deep roots short, both anchor pairs have delicate, nearly straight shafts and recurved tips. Dorsal bar, 2 pieces, slightly curved, clavate in outline, 0.063 long by 0.009 wide, not fused to ventral bar or each other as described by Mizelle and Blatz (1941), but anchored to the haptor mesially by stout muscular masses and articulated with dorsal anchors laterally. Ventral bar elongate, slightly curved, 0.163 long by 0.004 wide, with pointed ends and a longitudinal furrow. Hooks marginal, mostly on haptoral lobes, delicate, 0.016 long, 1 pair situated near dorsal bars. Peduncle widened to opisthaptor, bearing spines and ornamented with transparent, lateral plaques which are striated by slight thickenings that may be homologous to the spines. Mouth not seen, probably midventral to level of eyespots. Pharynx circular in outline, 0.027 in diameter; esophagus short. Gut bifurcated, crura unramified, not confluent posteriorly. Testis ovoid to subtriangular in outline 0.034 long by 0.026 wide, equatorial in midline posterior to ovary; vas deferens to left of midline, extending sinuously to cirrus bulb. Cirrus complex consisting of an elongate cirrus bulb, cirrus and accessory piece. Cirrus bulb small, elongate, to right of midline, opening into cirrus anteriorly; cirrus stout, curved, hollow tube, 0.054 long by 0.005 wide surrounded throughout most of its length by the accessory piece; accessory piece irregularly shaped, curved around cirrus and recurved on itself distally. Saccate structure interpreted as a prostate reservoir situated obliquely across body to left side, anterior to ovary, some prostate elements apparently in posterior end of this body. Genital pore common, opening dextroventrally at one-third level of body. Ovary tubular to saccate, pretesticular, looped over right crus of intestine; short oviduct proceeding anteriorly. Ootype short; uterus a wide, thin walled duct opening at genital pore. Vaginal pore nearly midventral at posterior one-third level; vaginal tube joining oviduct near junction of Mehlis' gland. Mehlis' gland unicellular. Vitellaria follicular, mostly near intestinal crura, extensive lateral fields just posterior to pharynx, extending nearly to haptor posteriorly; vitellooducts converging to oviduct immediately anterior to ovary. Egg spherical, 0.068 in

diameter, with a short clavate filament. Four eyespots antero-dorsal to pharynx.

A study of the cotype material, USNM Helm. Coll. slide No. 36822, and specimens in the present collection showed that the original authors, Mizelle and Blatz (1941), were mistaken concerning the dorsal bars which they described as medially fused. There are actually two widely separated dorsal bars. In addition, these authors did not mention the cuticular spines and lateral plaques. Also, a vaginal pore is probably present ventrally.

The definite diplectanid characteristics of *R. rhabdosynochus* revealed by the present study necessitate its transfer from Tetraochninae to Diplectaninae. These characters are: (1) three haptor bars, two dorsal, (2) furrowed ventral bar, (3) anchor shape, (4) posterior body spines, (5) ovary looped around intestinal crus, (6) lateral plaques.

SUMMARY AND CONCLUSIONS

In this, the third installment of the present series of papers dealing with monogenetic trematodes from the Gulf of Mexico, it is suggested that the genus *Tetrancistrum* Goto and Kikuchi, 1917 badly needs redefinition. The diagnosis of the subfamily Diplectaninae Monticelli, 1903 is emended in order to include the genera *Rhabdosynochus* Mizelle and Blatz, 1941 *emend.* and *Rhamnocercus* Monaco, Wood and Mizelle, 1954 *emend.* The transfer of *Rhamnocercus* to the subfamily Diplectaninae because of its diplectanid characteristics necessitates rejection of the subfamily Rhamnocercinae Monaco, Wood and Mizelle, 1954 of which it is the type genus. It is concluded that the status of *Neodiplectanum* Mizelle and Blatz, 1941 requires further clarification.

In all, three new and two previously described species are described and/or discussed. These are *Pseudohaliotrema mugilinus* n. sp., *Diplectanum bilobatus* n. sp., *Rhamnocercus bairdiella* n. sp., *Tetrancistrum longiphallus* (MacCallum, 1915) Price, 1937 and *Rhabdosynochus rhabdosynochus* Mizelle and Blatz, 1941. Because the preceding monogeneids were actually recovered from Gulf hosts this constitutes a new locality report for all. In addition, *Haploleidus vanbenedenia* (Parona and Perugia, 1890) Palombi, 1949 is briefly treated. It is suggested that *Tetrancistrum lutiani* Tubanguí, 1931 probably belongs in another genus. As a result of restudy of the type material certain points of the morphology

of *Rhahnocercus rhahnocercus* Monaco, Wood and Mizelle, 1954 are clarified.

This paper completes presentation of data on members of the superfamily Gyrodactyloidea Johnston and Tiegs, 1922. Part IV will treat the superfamily Capsaloidea Price, 1936.

LITERATURE CITED

- GOTO, S., and H. KIKUCHI
 1917. Two new trematodes of the family Gyrodactylidae. Jour. Coll. Sci. Tokyo 39: 1-22.
- HARGIS, W. J., JR.
 1954. Monogenetic trematodes of some Gulf of Mexico fishes. Dissertation Abstracts, Zoology Sect., Publ. No. 8258, Vol. XIV (1954): 1115-1116.
- MacCALLUM, G. A.
 1915. Some new species of ectoparasitic trematodes. Zoologica 1: 303-410.
- MIZELLE, J. D., and V. BLATZ
 1941. Studies on monogenetic trematodes. VI. Two new dactylogyrid genera from Florida fishes. Amer. Midl. Nat. 26: 105-109.
- MONACO, L. H., R. A. WOOD and J. D. MIZELLE
 1954. Studies on monogenetic trematodes. XVI. Rhahnocercinae, a new subfamily of Dactylogyridae. *Ibid.* 52: 129-132.
- PEARSE, A. S.
 1949. Observations on flatworms and nemerteans collected at Beaufort, N. C. Proc. U. S. Nat. Mus. 100: 25-38.
- PRICE, E. W.
 1937. North American monogenetic trematodes. I. The superfamily Gyrodactyloidea. (Cont.). Jour. Wash. Acad. Sci. 27: 146-164.
- SPROSTON, N. G.
 1946. A synopsis of the monogenetic trematodes. Trans. Zool. Soc. London. 25: 185-600.
- YAMAGUTI, S.
 1953. Parasitic worms mainly from Celebes. Part 2. Monogenetic trematodes of fishes. Acta Med. Okayama 8: 203-256.

RESEARCH NOTES

FURTHER ADDITIONS TO THE KNOWN FISH FAUNA IN THE VICINITY OF CEDAR KEY, FLORIDA.—Since the recent reports by Reid (1954, Bull. Mar. Sci. of the Gulf and Carib., 4(1): 1-94), Kilby (1955, Tulane Stud. Zool., *in press*), and Caldwell (1954, Quart. Jour. Fla. Acad. Sci., 17(3): 182-184), the following species of fish have been identified from Cedar Key, Levy County, Florida. For the purposes of this and the papers cited above, the area encompassed in citing records is the saltwater area regularly visited by fishermen from Cedar Key (a maximum of 15 nautical miles from the town). Unless otherwise indicated, the specimens listed below are deposited in the University of Florida fish collection. Measurements are expressed as standard length.

Scomberomorus cavalla (Cuvier & Valenciennes). King Mackerel. Though no specimens are available in the University collections, this species is frequently taken in the more open waters some 5 to 10 nautical miles from the town, primarily during the months of April and May.

Otophidium omostigmum (Jordan & Gilbert). Spotted Cusk Eel. A 161 mm. specimen was collected about March 10, 1953, by a commercial bait-shrimp fisherman in 3 fathoms on a grassy flat at night. Though this specimen was reported in a recent study of this species (Briggs and Caldwell, *Copeia*, *in press*), it is included here in order that the Cedar Key list remain consolidated.

Balistes caprisus Gmelin. Common Triggerfish. A 281 mm. specimen was gaffed on October 10, 1954, by Dr. E. Lowe Pierce of the University of Florida as it rose to the surface at the "pound nets" (a group of pilings located some 12 miles from the town near the end of a long shallow sand bar known as Seahorse Reef).—David K. Caldwell, Department of Biology, University of Florida.

THE AGED POPULATION OF FLORIDA: NUMBERS, PROPORTIONS, AND CHARACTERISTICS

IRVING L. WEBBER

*Department of Sociology and Anthropology
University of Florida*

A major demographic development in the United States during the present century has been a marked increase in the number of older people and in the share of the total population that they comprise. This increase has been distributed unequally among the states. Florida had less than its proportionate number of the aged as recently as 1940 and by 1950 its percentage only slightly exceeded the national average. Yet the state's older population had grown at an amazing rate. In the first half of the century those 65 and over increased by 1603 per cent compared with 424 per cent for the total population; in every decade since 1880 the older population showed much greater proportional gains than the total population. Migration of people at or near the retirement ages has played a significant role in these changes.

If, as seems likely, this trend continues, the social and economic impact on the state will become progressively more important. The purpose of this paper is to analyze the characteristics of the aged component of the population with data from the 1950 census (U. S. Bureau of the Census, 1952). Because it is customary to do so and because census tables lend themselves to it, age 65 will arbitrarily be regarded as the beginning of "old age" in spite of the many shortcomings of such an assumption.

NUMBER AND REGIONAL DISTRIBUTION

The United States Census shows that as of April 1, 1950 the population of Florida aged 65 and over numbered 237,474. At the census date there were 12,269,537 persons in the aged group in the United States. Older people comprised 8.6 per cent of the population of Florida and 8.1 per cent of the population of the nation. In both state and nation, the numbers of older people had increased during the preceding decade at a rate far greater than that of the general population: nearly twice as rapidly in the state and more than twice as rapidly in the nation.

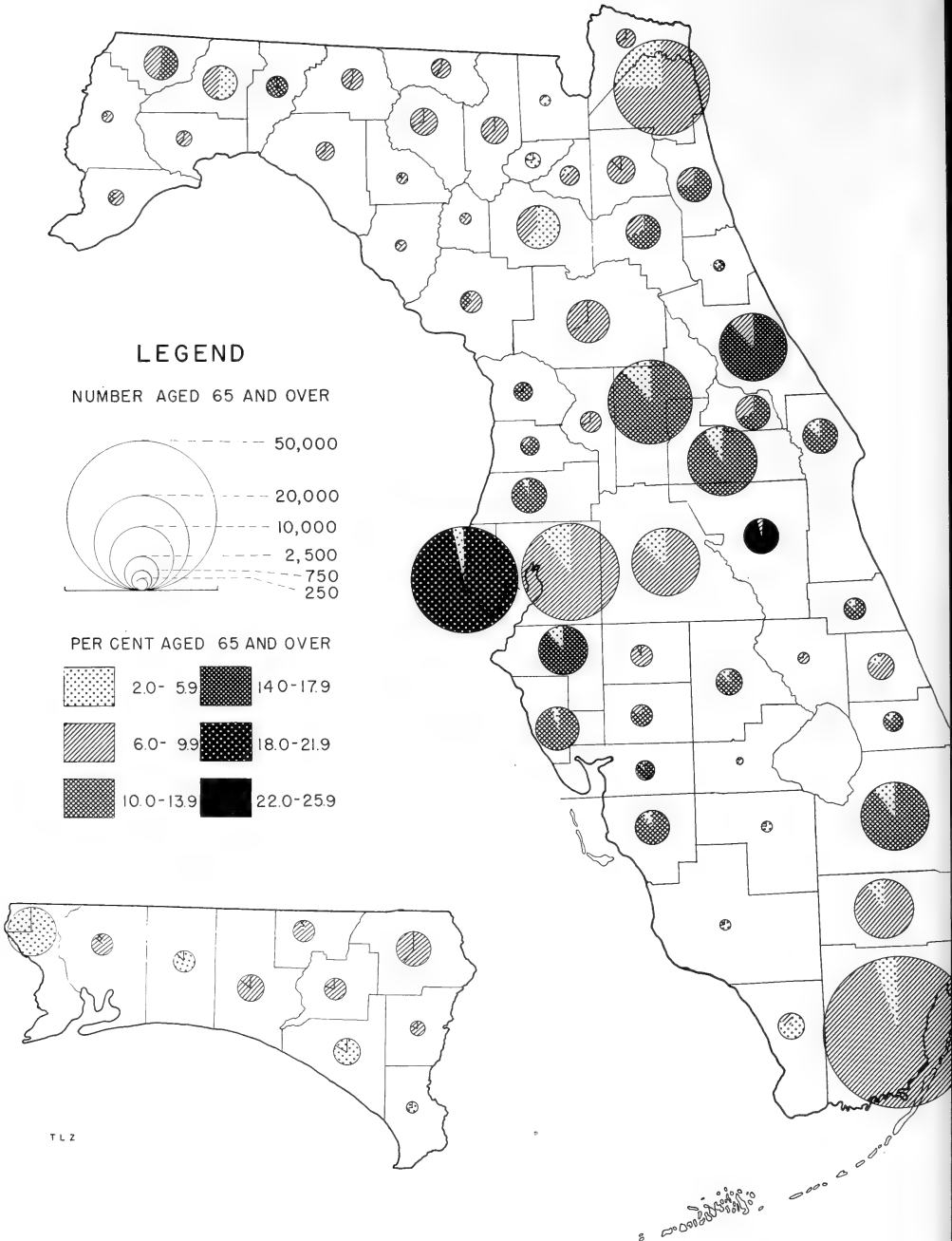

Figure 1.—Absolute and Relative Importance of the Population Aged 65 and Over, by Race, Florida, 1950. (Starting at 12 o'clock on the circles and reading clockwise, the first segment represents the aged white population and the second the aged Negro population. Source: U. S. Bureau of the Census. *U. S. Census of Population: 1950. Vol. II, Characteristics of the Population, Part 10, Florida, Chapter B, Table 41.* U. S. Government Printing Office, Washington, D. C., 1952.)

Florida's amazing increase of 81.0 per cent for its older population between 1940 and 1950 was due in large part to gains resulting from migration into the state of retired persons seeking the advantages of a mild climate. Hitt (1954) has calculated that the state gained 66,000 elderly persons through migration during the decade and that this increment accounted for 62.5 per cent of the total increase of oldsters. Only Arizona and California experienced net migration gains between 1940 and 1950 that approached that of Florida in terms of the part they played in the increase in the aged population.

The manner in which the older population of Florida was distributed in the state at the time of the latest decennial census is shown in Figure 1 by the size of the circles appearing in each of the 67 counties. Dade County, with nearly 38,000 persons aged 65 and over, was outstanding in this respect, while Pinellas County, in which St. Petersburg is situated, had about 30,000 in the older category. Hillsborough County's 20,000 and Duval County's 18,000 likewise placed these jurisdictions among those with the largest numbers of oldsters.

The important role that migration has played, considered along with the fact that this interstate movement has been almost entirely limited to white persons, provides the key to an understanding of the distribution of Florida's oldsters. Turning first to the racial factor, it is essential to understand that older white people make up a significantly larger share of the total white population than do aged Negroes of the total Negro component. In 1950 more than one in every 11 white persons was 65 or over, while less than one in every 18 Negroes was in that age group. The greater importance of the aged in the white segment reflects both the more favorable mortality experience of the majority group and the tremendous part that migration has had.

An imaginary line drawn between Ponte Vedra Beach on the upper east coast and Yankeetown on the west coast a few miles south of Cedar Keys divides the state into two sections which are rather dissimilar so far as the aged white population is concerned. In all but two of the counties lying north and west of this line white oldsters comprise a smaller share of the population than the state average of 9.4 per cent. The two counties in which the aged occupy a more important place are Gadsden (10.3 per cent) and Jefferson (10.2 per cent). The first has experienced population

gains during the past two decades far below those of the state as a whole. In addition, a considerable share of the inmates of the State Mental Hospital, situated in Chattahoochee, are 65 and over. Jefferson County lost population in both decades. The concentration of older people in Jefferson County and to a lesser extent in Gadsden County can therefore be understood as resulting from the exodus of younger persons, leaving oldsters to loom larger in the consequent age structure. We may conclude, then, that Northwest Florida has not in general received a disproportionately large migration of older people.

On the other hand, in a majority of the counties lying south of the line spanning the state between Ponte Vedra Beach and Yankeetown older white persons are relatively more important than they are in the state as a whole. This region includes counties—notably Osceola with 23.5 per cent and Pinellas with 20.6 per cent—with decided concentrations of elderly white people, far exceeding the state average. However, the eleven counties in the southern section which the census revealed have lower proportions of the aged than the state call for additional comment.

It will be observed that for the most part the largest proportions of older white persons in the southern section are found north of the Caloosahatchee River in counties on the east and west coasts. With few exceptions the counties which depart from the usual regional pattern with respect to the share of aged are of two classes, those in the extreme southern part of the state and those in the interior of the peninsula. In the case of counties in the southernmost part of the state, Monroe (4.5 per cent), Collier (5.2 per cent), and Hendry (4.9 per cent) reveal considerable underrepresentation of older whites, while Dade (8.4 per cent) and Broward (9.1 per cent) are not far below the state average. Counties without coastlines in which the aged appear in smaller proportions are Glades (7.5 per cent), Okeechobee, Polk (8.8 per cent), and Sumter (8.0 per cent). The two remaining counties in which white oldsters represent less than 9.4 per cent of the population are Hillsborough (8.5 per cent) and St. Lucie (8.2 per cent), both of which are coastal areas.

On the basis of these data and knowledge about growth trends we may note that South Florida, as defined above, has been characterized by a much greater influx of older migrants than is true of Northwest Florida. Furthermore, the central and northern coun-

ties of the southern section had in 1950 more marked concentrations of older white people in proportion to total white population than those in the southern part of the section. Two factors have probably had a particularly important part in determining this distribution: the attraction that coastal areas have for aged migrants and the reputations certain communities have built up as retirement towns and cities. On an even more fundamental level, the basic difference between the northwest section and the southern section probably results from the definition of "Florida" by residents of northern and midwestern states as the peninsular part of the state. White older people in the northwest section in 1950 made up 6.2 per cent of the white population; by contrast this age group in the southern section accounted for 10.8 per cent of the white segment.

The distribution of the older Negro population by county suggests a slightly different sectional division based on a line crossing the state approximately between Marineland on the Atlantic and Arepika, south of Wewahitchka Springs, on the Gulf. By and large, counties lying north and west of that line have more than their proportional share of aged Negroes; those south of the line have a deficiency in terms of the state average of 5.6 per cent for persons aged 65 and over as a part of the Negro population. In general, then, Northwest Florida's population includes a smaller share of aged whites and a larger share of aged Negroes than the state taken as a whole, while the reverse holds true for South Florida as defined for this purpose.

A few counties in the northwest section and several in the southern section depart somewhat from the general pattern for distribution of older Negroes. Escambia (5.4 per cent), Bradford (5.5 per cent), and Duval (5.3 per cent) are close to the state average, while Bay (4.5 per cent), Gulf (4.6 per cent), and Union (2.9 per cent) are other northwest counties in which aged Negroes make up a relatively smaller part of the population. In the southern section, eight counties—Brevard, Hillsborough, Lake, Manatee, Martin, Pasco, Pinellas, and St. Lucie—had in 1950 between 5.6 and 6.0 per cent of their Negro population in the aged category and thus exceed the state average only slightly. In a few other counties the differences were considerably greater. These included Charlotte (10.0 per cent), Hardee and Osceola (8.7 per cent), Okeechobee (8.4 per cent), Monroe (8.1 per cent), DeSoto (7.9 per cent), Volusia (6.8 per cent), and Seminole (6.0 per cent). Nevertheless,

when the two sections are taken as wholes, the contrast is clear enough. The northwest region had 6.8 per cent of its Negroes in the aged category, while the southern region had 4.6 per cent of its Negroes in that age range.

RACE AND NATIVITY

The importance of the racial factor in an analysis of the older population of Florida has already been noted. Migration to the state for retirement has been almost entirely a phenomenon of the white race. Counties, cities, towns, and villages which function to an unusual extent as residential communities for older white migrants are faced with problems quite different in nature and scope from those in which the number of aged Negroes, most of whom have probably been lifelong residents of these places, is relatively large. Florida resembles the nation in having a higher proportion of elderly people in the white than in the nonwhite population, but the aged are considerably more important in the white population of the state than in that of the nation.

In 1950 the foreign born were relatively much more important in the aged population than in the total population of the state. About 17 per cent of white oldesters reported that they were born in foreign countries, compared with less than six per cent of the total white population. Among Negroes, foreign-born persons were of negligible importance, the 970 in that category constituting less than three per cent of the aged of that race.

It was true, nevertheless, even for nonwhites, that the population of all ages had a considerably smaller proportion of non-native residents. The relatively large percentage of foreign-born persons among older Florida white people is no doubt due to two factors: (1) the great tide of immigration into the United States during the second half of the nineteenth century and the early decades of the twentieth century and (2) the migration of older persons from the Northeastern and Middle States, where the majority of the newcomers took up residence.

THE RATIO OF MEN TO WOMEN

In the United States women outnumber men beginning in the late teens, and the unbalance between numbers of the two sexes becomes greater as the years pass. At age 65 and over there were

in 1950 less than 90 men per 100 women. This situation reflects primarily the fact that death rates for males are higher than for females.

In Florida older women outnumber older men, but the sex ratio—number of men per 100 women—is not as low as that of the nation. At these older ages there were in 1950 among the white population about 95 men per 100 women and among the Negro population over 99 men per 100 women. So far as the white group is concerned, the relatively high sex ratio probably reflects a selective factor which results in the migration to Florida of disproportionately large numbers of men. On the basis of residence, sex ratios for older people are highest in rural farm areas, slightly lower in rural-nonfarm areas, and lowest in urban areas, a generalization which holds for both races.

AGE

The widespread practice of considering the aged as a single category of persons aged 65 and over has tended to cover up significant aspects of their distribution by age. It is important that those responsible for programs touching older people know the proportions of this segment of the population remaining at the various ages up to 100 and over.

Tables published by the Bureau of the Census showing the number of persons enumerated in 1950 by single years of age reveal that about three-fourths of the population of Florida aged 65 and over had not reached the age of 76. Thus the first decade of the age range accounts for a large majority of the older population, leaving one-fourth to people, with ranks that thin rapidly, the remaining 25-year span to 100, when only a handful are left. Nearly half of Florida's white oldsters were below age 71, while about three-quarters had not attained the age of 76. Persons who were 80 and over accounted for only about 10 per cent of all white aged persons. Forty-five white men and women told the census takers that they were 100 years old or older. For men and women of this race, the age distributions were remarkably similar.

The Negro aged were concentrated to an even greater extent in the earlier ages of the 65-and-over category. Interestingly enough, far more Negroes than whites—85 against 45—reckoned their ages at 100 and over. The age distribution of the aged Negro

population, unlike that for the other race, showed a sex differential favorable to men.

In interpreting these data based on single years of age, it is wise to keep in mind two cautions: (1) the increasing skepticism with which age responses must be regarded as the reported ages become greater, and (2) the fact that the census tabulations are based on sample data and are therefore subject to sampling variability.

RESIDENCE

According to the 1950 census, those persons are urban who live in places of 2,500 or more inhabitants (whether or not the center is incorporated) and in the densely settled fringes around cities of 50,000 or more. Rural-farm dwellers are those who live on farms. The third residential class, rural nonfarm, consists of the residue, make up of persons living in nonfarm homes in the open country, in villages and hamlets with less than 2,500 inhabitants, and in some of the fringe areas around the smaller incorporated centers.

A large majority of Florida's older people—nearly 70 per cent—reside in urban areas. Most of the others were found in places classified as rural nonfarm. Less than 8 per cent made their homes on farms. For both races taken together, older people of the state were overrepresented in urban places and underrepresented in both rural-farm and rural-nonfarm areas compared with the total population. Older women were living in cities to an even greater extent than older men, but both sexes were found there in proportions higher than those for all males and females in the state.

An analysis by race brings out significant differences in residence. Well over 70 per cent of white persons aged 65 and over were enumerated in urban areas, and an additional 22 per cent were counted in rural-nonfarm places. Thus less than seven per cent of aged whites lived on farms. As in the case of the total age group, white oldsters were present in disproportionately large numbers in cities by comparison with the total white population.

By contrast less than 59 per cent of the aged Negroes made their homes in urban places, about 30 per cent resided in rural-nonfarm places, and 12 per cent were rural-farm dwellers. The greater tendency for older Negroes to be found on farms reflected a lower concentration in urban areas and a greater concentration in rural-nonfarm and rural-farm areas than was true for Negroes of all ages.

MARITAL STATUS

In 1950 more than half of the older persons in Florida's population were married and nearly two-fifths were widowed. About five per cent reported that they had never been married, and less than two per cent indicated that they were divorced. Of the 54 per cent in the married status, about three per cent were living apart from wife or husband. The pattern of marital status differed somewhat from that of older people in the United States generally. In the nation a higher proportion of persons in this population group were single and a lower proportion of the males were married. Also a slightly higher proportion of the nation's aged men were widowed. These differences may reflect the tendency for the migration of elderly people to places of mild climate to select healthier and more active persons.

As would be expected, there were rather marked differences between the status of persons aged 65-74 and those 75 years of age and over. In the lower age category, 60 per cent of all persons were married; at 75 and over, only 41 per cent were in that status. At ages 65 through 74 a third were widowed; in the older age group, over half were widowed. It is interesting to note that the proportion never married was slightly greater at the more advanced ages, while the reverse was true for divorced persons. In general, the proportion of persons married was much higher for men than for women, especially at the higher ages. The opposite situation prevailed for widowhood, and the share of older women who were widows was particularly great at 75 and over.

Whites aged 65 and over showed higher proportions of single, married, and divorced persons than Negroes. These differentials held true for both the 65-through-74 and the 75-and-over age groups.

EDUCATION

It is well known that older people are at a disadvantage with respect to formal educational status. In the United States the median school years completed for the population aged 25 and over was in 1950 9.3 compared with 8.2 for those 65 and over. A differential unfavorable to the aged prevails for those who have had no formal schooling, for high school, and for college. Despite the prevalence of a large share of Negroes in Florida's older group,

its educational status is somewhat better than that of oldsters in the nation at large.

The usual well-established differentials are found. The educational level of aged Negroes is much lower than that of aged whites. Women in both races have had more years of school than men. Median years of school completed are highest for older people living in urban areas, lowest for those residing on farms, while those in rural nonfarm areas occupy an intermediate position.

CONCLUSION

It would be desirable to extend this analysis of the characteristics of older people in Florida to several other significant aspects such as income status, labor force participation, and employment patterns, but time precludes this for the present. Moreover, a more detailed comparison of the state's oldsters with those in the nation and its socio-economic regions must await the publication of more thorough studies on those levels than are now available. Although students of population have devoted considerable attention to the numbers of the aged and their geographic distribution, very little effort has been directed to the task of determining the composition of this age-group in terms of the usual sociological categories. There is a real need for demographers to interpret the rich store of data on our senior citizens which is to be found in the publications of the Bureau of the Census.

LITERATURE CITED

U. S. BUREAU OF THE CENSUS

1952. *U. S. Census of Population: 1950*. Vol. II. *Characteristics of the Population*, Part 10, Florida, Chaps. B and C. Government Printing Office, Washington, D. C.

HITT, HOMER L.

1954. The Role of Migration in Population Change Among the Aged. *Amer. Sociological Review*. 19(April): 194-200.

A PRELIMINARY SURVEY OF THE WATER BEETLE FAUNA OF GLEN JULIA SPRINGS, FLORIDA ¹

FRANK N. YOUNG
Indiana University

The water beetle fauna of most of the larger springs in Florida is disappointingly meagre. Often only a few common species can be collected after intensive search, or a few species of Gyrinidae flood the surface with great schools. When a spring in fairly natural condition can be found the smaller beetles are mostly representative of the stream fauna of the area; and occur only along the edges in protected backwaters or similar situations. In consequence, the writer was pleasantly surprised at the diversity of habitats and the richness of the water beetle associations found at Glen Julia Springs near Mt. Pleasant in Gadsden County, Florida.

The collections from the Glen Julia Springs area were not confined to a single main boil and the resulting run, as is necessary in the case of most large springs. The richness of the fauna thus reflects the occurrence of specialized situations which have either not been found in other areas, or which occur in such small patches that they are unable to support characteristic associations. The occurrence of several rare or relict species emphasizes the importance of the concept of minor habitats, the "niches écologiques" of Paulian (1948), and may have very broad implications in regard to the supposedly relict fauna of this region of Florida and southern Georgia and Alabama.

The Glen Julia Springs issue from the sides of a ravine about 50 feet deep. The resulting small stream flows eventually into South Mosquito Creek, a tributary of the Apalachicola River. The head of the ravine where collections were made is surrounded by an extensive area of Norfolk sandy loam (Fippin and Root, 1903). The slopes are forested with a mesic hammock containing broad-leaved magnolia, laurel oak, some white oak, and scattered *Pinus glabra* with an understory of *Batodendron arboreum* and Florida dogwood. This merges with a more xeric vegetational association on the upper slopes. The sides of the ravine are not so precipitous

¹Contribution No. 580 from the Zoological Laboratories of Indiana University. Field work aided by a grant from U. S. National Park Service through contract with the Florida State Museum and The Department of Biology at the University of Florida.

as in the "Torreya Ravines" farther south in Liberty County, but there is obviously a very marked difference in local edaphic and climatic conditions within the ravines in contrast to the surrounding drier area.

According to Ferguson, *et al.* (1947), eight or nine small springs issue from fissures in the rocks along the bottom of the ravine. The rate of flow in May, 1946, was about 0.50 million gallons per day and the temperature 69° F. An analysis of the water (Ferguson *et al.*, 1947) indicates that it is of unusual softness compared to other springs in Florida.

Part of the spring flow is diverted into a swimming pool at the bottom of the main ravine, and the area is designated as a county park. We saw little sign of recent use in June of 1954, however, and the pavilion and other "improvements" have fallen into disrepair.

Despite the extensive human intervention, much of the area appears to be in fairly natural condition. Above the swimming pool small streams flow from the springs through little valleys down to the main pool, and below the pool a small stream carries away the overflow. The area was intensively explored for water beetles during June of 1954 by the writer and Mr. Sulvester N. Brown. Twelve collections from specific minor habitats include over 450 individuals representing 55 species and 29 genera of the families Dytiscidae, Noteridae, Haliplidae, Hydrochidae, Hydrophilidae, and Limnebiidae. No Dryopidae or Elmidae were taken, but some must occur in the stream or spring runs. No Gyrinidae were seen in any of the situations investigated, which probably reflects the small size of most of the aquatic habitats available.

An attempt was made to recognize minor habitats of significance in the occurrence of aquatic beetles. In this we were only partially successful because of the often very complex interrelationship of water, vegetation, debris, types of bottom, rate of flow, and various micro-topographical features. The following outline of minor habitats is therefore partly theoretical, and derived in part from a subsequent analysis of the beetles present:

A. Lotic situations:

1. Small sand-bottomed streams, flowing rapidly down fairly steep slopes; with alternating sand-bottomed portions, small cataracts, and pools with deposits of leaf drift and other debris
 - a. In sand along margin of sand-bottomed portions (negative)

- b. In and on debris in pools
 - c. In *Sphagnum* moss dangling in water (negative)
 - 2. Small sand-bottomed stream with moderate rate of flow, below the spring-head area
 - a. In sand along margin in sand-bottomed portions (negative)
 - b. In and under margin where tiny undercut banks have developed
 - c. In and on debris collected in backwaters
 - 3. Seepage at base of slopes, with slight flow, usually through beds of *Sphagnum* and other aquatic mosses.
- B. Lenitic or semi-lenitic situations:
- 1. Small pool, fed by seepage from base of slopes (at A-3). Pool fairly choked with *Ludwigia*, grasses, sedges, dead leaves, sticks, and other organic debris so that the water was only 1 to 3 inches deep over a very flocculent, odoriferous, bottom of organic material
 - 2. Small pool with water up to 6 inches deep, and fairly clear of vegetation, but surrounded by *Typha* and other emergent plants. Partly fed from seepage, and partly from back-flow from swimming pool
 - 3. Large pool formed by damming of spring flow. Water bluish and clear, similar to spring boils in area, but with only very slight flow through drain at center
 - a. On surface (negative)
 - b. Along sandy margins among emergent vegetation of *Typha*, grasses and sedges.

The distribution of the water beetles in these situations is presented in the following table:

DISTRIBUTION OF WATER BEETLES IN MINOR HABITATS AT GLEN JULIA SPRINGS

	Lotic			Lenitic		
	A-1	A-2	A-3	B-1	B-2	B-3
DYTISCIDAE						
<i>Agabetes acuductus</i> (Harris) -----				7	1	
<i>Bidessus cf. affinis</i> (Say) -----				1		
<i>Bidessus lacustris</i> (Say) -----				1		8
* <i>Bidessus</i> n. sp. cf. <i>falli</i> Young -----				9	3	12
<i>Bidessonotus inconspicuus</i> (LeConte) -----				9	5	
<i>Bidessonotus longovalis</i> (Blatchley) -----				3		6
<i>Bidessonotus pulicarius</i> (Aubé) -----				1		2
<i>Celina angustata</i> Aubé? -----				1	1	
<i>Copelatus caelatipennis</i> Aubé? -----		1	1	5	3	
<i>Copelatus glyphicus</i> (Say) -----				1		
<i>Coptotomus interrogatus obscurus</i> Sharp ----				1	1	2
<i>Desmopachria</i> sp. cf. <i>grana</i> (LeConte) -----				2		
<i>Graphoderus liberus</i> (Say) -----				1	2	
<i>Hydaticus bimarginatus</i> (Say) -----		1	1	32	12	

DISTRIBUTION OF WATER BEETLES IN MINOR HABITATS AT
GLEN JULIA SPRINGS—(Concluded)

	Lotic			Lenitic		
	A-1	A-2	A-3	B-1	B-2	B-3
<i>Hydroporus blanchardi</i> Sherman?		2				
<i>Hydroporus brevicornis</i> Fall			2	1	1	
* <i>Hydroporus filiulus</i> Fall?			1			
<i>Hydroporus lobatus</i> Sharp		1				18
<i>Hydroporus niger</i> Say				2		
<i>Hydroporus shermani</i> Fall?		1				
* <i>Hydroporus venustus</i> LeConte						1
* <i>Hydroporus</i> n. sp. cf. <i>oblitus</i> Aubé			3			
<i>Ilybius oblitus</i> Sharp?				1		1
<i>Laccophilus fasciatus</i> Aubé				1		1
<i>Laccophilus proximus</i> Say				6		4
<i>Matus ovatus blatchleyi</i> Leech?					4	
<i>Rantus calidus</i> (Fabricius)	1			16	12	
<i>Thermonectus basillaris</i> (Harris)				4	2	
NOTERIDAE						
<i>Hydrocanthus oblongus</i> Sharp				1	2	
HALIPLIDAE						
<i>Peltodytes</i> spp.						9
HYDROCHIDAE						
<i>Hydrochus minimus</i> Blatchley?						1
<i>Hydrochus foveatus</i> Haldeman						3
<i>Hydrochus rugosus</i> Mulsant				2		2
HYDROPHILIDAE						
<i>Berosus</i> sp. cf. <i>striatus</i> Say					1	3
* <i>Berosus pantherinus</i> LeConte						1
<i>Crenitulus suturalis</i> (LeConte)						1
<i>Cymbiodyta blanchardi</i> Horn?		4	3			
<i>Cymbiodyta vindicata</i> Fall?				1		
<i>Enochrus cinctus</i> (Say)		1	1	24	1	
<i>Enochrus consors</i> (LeConte)				2		
<i>Enochrus ochraceus</i> (Melsheimer)		2	9	4		1
<i>Enochrus perplexus</i> (LeConte)?				3		
<i>Enochrus sublongus</i> (Fall)		1	1	11		3
<i>Helocombus bifidus</i> (LeConte)				6		
<i>Hydrobius tumidus</i> LeConte		1		4	1	1
<i>Hydrochara</i> sp.?			1	3	1	1
<i>Neohydrophilus castus</i> (Say)				1		
<i>Paracymus subcupreus</i> (Say)		2		60		9
<i>Tropisternus blatchleyi</i> D'Orchymont				14	8	3
<i>Tropisternus natator</i> D'Orchymont?				5	4	
<i>Tropisternus lateralis nimbatus</i> (Say)				2		1
<i>Tropisternus mexicanus striolatus</i> (LeConte)				3	4	
LIMNEBIIDAE						
<i>Hydraena marginicollis</i> Kiesenwetter				2		

* New Florida records.

It is evident from the table that certain species are restricted to recognizable subdivisions of the major habitat. A comparison of the lists shows most of these restrictions quite clearly:

A-1 represents the extreme headwaters of a small spring-fed stream. The rate of flow and instability of the bottom are probably limiting factors. With the exception of the Dryopidae and Elmidae, water beetles are not well adapted to maintain position in such situations. The occurrence of *Rantus calidus* merely reflects the abundance of this highly vagile species in a nearby habitat.

A-2 represents a type of small stream typical of the region around Chattahoochee. The source of water seems to be less important than the bottom which is composed of shifting, micaceous sands. Along the banks of such a stream lateral seepage is usually extensively developed, and probably represent the actual breeding places of the typical beetles. In the streams themselves the principal concentrations of beetles are found along or under banks which have been undercut by the stream action or in small collections of debris. These concentrations may result from a sort of trapping action of current and shifting bottom, the fauna being constantly replenished from the seeps.

Hydroporus blanchardi? and *Cymbiodyta blanchardi*? are the only abundant species characteristic of such situations in this region. The small "burrowing" water beetles, such as *Hydroporus vittatipennis*, seldom extend up into these small lateral streams, but are more strictly confined to the sandy margins of the larger rivers, spring runs, and lower streams. *H. shermani* (of which Floridian specimens are doubtfully representative) may also occupy seepages along streams, but the occurrence of this species farther north seems to be largely correlated with larger silty bottomed streams with marginal vegetation. The remaining species listed can probably be ignored as having been washed out of other habitats up stream.

A-3 represents one of several types of seepage areas found in northern Florida. In this particular situation, seepage issues from a steep bank and flows for only a very short distance into a small pool. The actual seepage resents a special minor habitat in which tiny rivulets of water trickle through various aquatic mosses over a bottom of organic debris. Such a situation would be perpetually cool (tending to be about the average temperature of the region) in both winter and summer. Despite the minute area which most

similar seepages occupy, the general type of situation must be very extensively distributed because a number of groups of aquatic beetles are found almost anywhere that similar conditions occur. Important factors influencing water beetles seem to be the flow and relative coolness of the water together with the occurrence of mosses.

At Glen Julia Springs two very interesting species of the *oblitus* group of *Hydroporus* (*filiolus* and n. sp. cf. *oblitus*) were found in A-3. Both of these represent new records for Florida, and both may be new species. All of the members of this group which I have studied occur in springs or seepages with some notable exceptions in northern bogs and bog-like situations. The taxonomy is too confused at present to allow the clear separation of forms without very large series of specimens at hand. Nearly every isolated spring or seep seems to have a distinctive local population which could be separated from others on body shape, genitalia, punctation, coloration, or other characters. If these forms represent relicts of an ancient fauna such diversity would be expected, and the unravelling of their taxonomy will perhaps give us additional information on the probable geological history of the regions in which they occur.

Hydroporus brevicornis is another interesting species taken in the seepage and also in the pool below the seep (B-1). The general shape suggests that this insect is adapted to "burrowing" in unconsolidated organic material on the bottom. It is nearly always found in association with springs or seepages, and often where rheocrene springs flow out over peaty materials.

Among the other species taken in A-3 *Cymbiodyta blanchardi*? is probably characteristic of such situations as noted under A-2 above. *Enochrus ochraceus* occurs almost everywhere in the Eastern U. S. where detritus has accumulated in water so that its abundance is probably of little significance. The large predatory dytiscids in the pools below the seepage may have been responsible for reducing its numbers there. All of the remaining species must be considered accidental or at best sporadic inhabitants of seepages.

B-1 approaches a type of seepage often termed a "helocrene" spring, but combines features not usually found in such situations. Several minor habitats seem to have been telescoped upon one another. The great amount of living and dead vegetation present made part of the situation a veritable mosaic of small partitioned

habitats. Some of these represent situations very similar to those found in true woods ponds to judge from the presence of characteristic woods pond beetles, such as: *Graphoderus liberus*, *Agabetes acuductus*, *Desmopachria grana* complex, *Ilybius oblitus*?, *Enochrus cinctus*, *Helocombus bifidus*, *Hydrochara* sp., and *Hydrobius tumidus*. Most of the other species present occur in a wide variety of types of habitats in Florida and elsewhere.

Agabetes acuductus could be observed at night resting at the surface of minute poolets among the dead leaves and organic debris, exactly as I have seen them do in woods ponds in southern Michigan. When disturbed they dived to the bottom and burrowed into the debris. All of the specimens collected are somewhat larger and darker than northern individuals, and the Florida population may represent a distinct subspecies. So far the species has been recorded only from Alachua County, Florida, south of the Appalachian mountains.

The concentration of hydrophilids, bidessids, and other small beetles in the seepage pool rather than in the more open pool adjacent to it, may again reflect the abundance of predatory forms. The large amount of vegetation and debris in B-1 probably furnished hiding places and protection for the smaller species.

B-2, the open pool, adjacent to and in part continuous with B-1, produced a much less diverse water beetle fauna. Only two species found there were not also found in B-1 (*Matus ovatus blatchleyi* and a species of the *Berosus striatus* complex). Many of the specimens taken in B-1 and particularly in B-2 had the corners of the pronotum or the tips of the elytra chewed off or were lacking parts of the antennae or legs. This was particularly true of the hydrophilids. No specific cases of attacks by one water beetle on another were observed, but it seems highly probable that the many individuals of *Hydaticus* and *Rantus* were responsible for this damage.

The composition of the collections from the empoundment of the spring water (B-3) was about what might be expected. Fish were present in the deeper portions, and nearly all beetles were taken from the margin among emergent plants. The most striking feature of this association was the lack of the large species of *Hydaticus*, *Rantus* and *Thermonectus*, together with the addition of haliplids (*Peltodytes* spp.) and two species of Hydrochidae.

The greater abundance of *Bidessus lacustris* in B-3 confirms what

is now known concerning the occurrence of this species. It is characteristic of the edges of springs, streams, and ponds in this region where sandy or silty margins are present. The occurrence of a new species of *Bidessus* similar to *B. falli* is interesting. These tiny "burrowing" bidessids are apparently characteristic of the sandy or silty borders of clear water, usually flowing, throughout northern Florida, and apparently fill the niche of *Hydroporus mellitus*.

The total association from Glen Julia Springs reemphasizes the contrast between the Upland and Lowland water beetle faunas in Florida. The abundance of *Paracymus subcupreus* and the lack of *P. nanus* is striking. Another difference is evident in the species which occur in both types of situations. The specimens of *Matus ovatus blatchleyi* are larger and much lighter in color than specimens taken only a few miles to the south near Wilma in Liberty County, and the same applies to *Hydrocanthus oblongus* and *Coptotomus i. obscurus*.

The data presented here point up the difficulty of defining minor habitats or "niches écologiques" for aquatic beetles. A vast number of factors act upon the association of beetles in any particular situation. Some of these we can recognize in the field, such as: rate of flow of water, presence or absence of predators, presence or absence of organic debris, and the nature of the bottom. Other factors are either unrecognizable, except by instrumental analysis, or are very obscure in their operation. We seem a very long way from any precise definition of the definitive minor habitat except in most equivocal terms.

LITERATURE CITED

- FERGUSON, G. E., C. W. LINGHAM, S. K. LOVE and R. O. VERNON
1947. Springs of Florida. *Fla. Geol. Surv. Bull.* 31, pp. XII and 196, illus. (and folding map).
- FIPPEN, ELMER O., and A. S. ROOT
1903. Soil Survey of Gadsden County, Florida. *Field Operations Bur. of Soils*, pp. 331-353 (and folding map).
- PAULIAN, R.
1948. Notion, Limites et Importance des Niches Écologiques. *Rev. fr. d'Entom.* 15: 161-165.

A NEW RACE OF *MYOTIS AUSTRORIPARIUS* FROM THE
UPPER MISSISSIPPI VALLEY

DALE W. RICE
University of Florida

Pending the publication of a comprehensive account of the geographical distribution and variation of the *Myotis (Leuconoe) daubentoni* species group, I am presenting this preliminary description of a new race of *Myotis austroriparius*.

The generosity of the following individuals, who loaned specimens from their own private collections or from the institutional collections under their care, has made possible the determination of the characters of this rare bat: James R. Beer; James B. Cope, Joseph Moore Museum, Earlham College; Wayne H. Davis and W. Gene Frum; William H. Elder, University of Missouri Museum of Zoology; C. O. Handley, Jr., U. S. National Museum; Donald F. Hoffmeister, University of Illinois Museum of Natural History; C. M. Kirkpatrick, Purdue University Wildlife Laboratory; Charles E. Mohr; Russell E. Mumford; J. A. Sealander, University of Arkansas Zoology Department; and Philip W. Smith, Illinois Natural History Survey. I am especially indebted to H. B. Sherman for his cooperation and advice.

MYOTIS AUSTRORIPARIUS MUMFORDI new subspecies

HOLOTYPE.—United States National Museum No. 293800, adult male, skin and skull. Collected by Russell E. Mumford, 11 January 1949.

TYPE LOCALITY.—Bronson's Cave, in Spring Mill State Park, 3 miles east of Mitchell, Lawrence County, Indiana.

DIAGNOSIS.—This race occurs only in the gray color phase. Adults with pelage of upperparts Black to Fuscous-Black basally, and Hair Brown to Chaetura Drab on the apical fourth. Pelage of underparts Black basally, and White to Pale Smoke Gray on the apical fifth. Mean length of third metacarpal 34.5 mm. (31.5 - 36.7). (Capitalized color terms are from Ridgway, 1912).

COMPARISONS.—Differs from *M. a. austroriparius* Rhoads, 1897, from Florida, in color. *M. a. mumfordi* has white underparts and

grayish upperparts, whereas *M. a. austroriparius* has pinkish-buff underparts and brownish upperparts. Differs from *M. a. gatesi* Lowery, 1943, from Louisiana, in color and length of third metacarpal. *M. a. mumfordi* occurs only in the gray phase, whereas *M. a. gatesi* occurs only in the red phase. The length of the third metacarpal of *M. a. mumfordi* is 33.0 mm. or greater in 95% of the specimens examined, whereas in *M. a. gatesi* it is less than 32.9 in six of the seven known specimens.

SPECIMENS EXAMINED.—Total, 102, as follows: Indiana: Lawrence County, Bronson's Cave, 15; Donaldson's Cave, 21; Upper Twin Cave, 14. Greene County, Ray's Cave, 1. Crawford County, Saltpetre Cave, 1. Illinois: Hardin County, Layoff Cave, 37; 2.5 miles northwest of Cave in Rock, 1; Cave Spring Cave, 8; Griffith Cave, 1. Alexander County, 0.5 mile north of Olive Branch, 1. Arkansas: Garland County, 12 miles northwest of Hot Springs, 2.

This race is named for Russell E. Mumford, whose studies on the bats of Indiana have greatly added to our knowledge of the habits of these rare bats.

LITERATURE CITED

LOWERY, GEORGE H., JR.

1943. Checklist of the mammals of Louisiana and adjacent waters. Occ. Papers Mus. Zool., La. State Univ., 13: 213-257.

RHOADS, SAMUEL N.

1897. A new southeastern race of the little brown bat. Proc. Acad. Nat. Sci., Philadelphia, 1897: 227-228.

RIDGWAY, ROBERT

1912. Color standards and color nomenclature.

FOOD OF THE MUDFISH (*AMIA CALVA*) IN LAKE NEWNAN,
FLORIDA, IN RELATION TO ITS MANAGEMENT ¹

FREDERICK H. BERRY
University of Florida

My study of the mudfish, or bowfin (*Amia calva*), was begun in an attempt to determine if this species effected any appreciable control on the tremendous and presumably undesirable population of gizzard shad (*Dorosoma cepedianum*) in Lake Newnan. The scarcity of information on the food habits of mudfish suggested that the observations be extended. The carnivorous nature of the species has been long recognized. While Schneberger (1937) concluded that the young (under three inches in length) had not become piscivorous, others have shown that fish comprise the majority of the diet. Miles (1912) declared that the mudfish lives on the same food as the largemouth black bass. Forbes and Richardson (1920) stated that a third of the "entirely animal food" of the stomachs they examined was fish. Scott (1938) found that over half of the stomachs he examined contained fish. Studies by Lagler and Hubbs (1940) and Lagler and Applegate (1942) showed approximately the same results.

Lake Newnan is situated four miles east of Gainesville, Alachua County, Florida. It receives surface runoff mainly from Hatchett Creek and several smaller creeks to the north and from hardwood swamps and pine flatwoods to the east, north, and west. The permanent outlet is through Prairie Creek to the south. Camp's Canal diverts the outflow through the River Styx into the Orange Lake-Orange Creek-Oklawaha River-St. Johns River drainage system. The kidney shaped lake basin covers nearly 6,200 acres and has a shore line of about eleven miles. Water level fluctuates about three feet from dry to rainy seasons. In a gradual slope from the shore the water attains a maximum depth of about twelve feet near the middle of the lake during the drier months. The average depth during this period is estimated to be four feet. The basin of clay-sand is exposed in wave washed areas near the shore; but it is mostly covered by a layer of flocculent liver mud and fine plant debris which is over ten feet in thickness near the middle.

¹ I am indebted to Mr. Wayne Hook and other members of the Florida Game and Fresh Water Fish Commission for their assistance.

Table 1.—Food of the Mudfish.

Date 1954	No. of Stomachs Contain- ing Each Type Food				No. of Stomachs Empty	No. of Stomachs Containing a Single Type or Combination of Types of Food									No. of Stomachs Containing Food	No. of Stomachs Examined
	Speckled Perch	Cattfish	Fish Remains	Miscellaneous		Speckled Perch & Crayfish	Speckled Perch Only	Speckled Perch & Fish Remains	Speckled Perch, Cattfish & Fish Rem.	Cattfish & Fish Remains	Cattfish Only	Fish Remains	Scales	Miscellaneous		
March	7	6	10	1a	1	1	5	1		5	1	4			17	18
April	6	3	7		2	3	2	1	1	1	3				11	13
May	9	6	6		3	9			4	2	5	3			23	26
June	5	3	7	2b	8	3	2		1	2	2		2c		12	20
July		5	1	4d	6e					5	2	3	3		10	16
Nov.		4			1					4					4	5
Totals	27	27	31	7	21	1	20	5	1	11	15	16	6	2	77	98.

a, Crayfish

b, Gizzard

c, Clam Shell Remains

d, Scales Only

e, Trot Line Hook

The brownish, turbid water is frequently tinted green by the abundant phytoplankton. Zooplankters are also abundant.

The lake is bordered by baldcypress (*Taxodium distichum*). Other than filamentous algae, only a few scattered submerged aquatic plants and emergent aquatics occur in the lake. Finely branched submerged roots of the cypress trees appear to serve as a habitat for many of the smaller animals in the absence of other vegetation. The shore mats and floating rafts of water hyacinths (*Piaropus crassipes*) that once covered large portions of the lake have been greatly reduced. Two duckweeds (*Lemna minor* and *Spirodela polyrhiza*) are found inshore in association with the hyacinths.

Twenty-one species of fish have been collected in the lake, and five additional species have been recorded from the mouths of the creeks.

METHODS AND EQUIPMENT

The mudfish were obtained from the seining activities in Lake Newnan in concurrence with the rough fish removal program of the Florida Game and Fresh Water Fish Commission. After laying out the 1,600 yard haul seine, approximately three hours were required to complete the haul and to dip-net the fish from the enclosed pocket. The stomachs were placed in 10% formalin soon after the fish were weighed and measured. Early in the study, identification of the contents and relative degrees of digestion only were recorded. Later, volumetric measurements and length reconstructions of the contents were taken for further analyses. Records of the catch of the haul seine and of collections made with an otter trawl and a 40 foot bag seine were used to estimate the numbers and size ranges of other species in the lake related to this study. The stomachs of three mudfish, that had been force-fed living fish, were examined three hours after feeding in an attempt to obtain some idea of the rate and extent of digestion.

RESULTS

From March 2, 1954, through November 7, 1954, 98 specimens were obtained from 23 seine hauls. Of the 77 with particulate contents, 75 contained fish or fish remains. Of the two with non-fish contents: one contained parts of a clam shell (*Anodonta* sp.); the other, a bird-like gizzard. One stomach containing fish also contained two crayfish (*Procambarus* sp.). Several days after the

capture of this fish, the lake was sprayed with 2-4-D to destroy the water hyacinths. Seining with the small mesh bag seine showed a subsequent scarcity of crayfish from most areas of the lake shore. This observation is included because crayfish were found in abundance in mudfish stomachs in other studies (Forbes and Richardson, Scott, Lagler and Hubbs, Lagler and Applegate). My examination of the stomachs of one specimen taken from Silver Springs, Florida, and one from Orange Lake, Florida, revealed crayfish remains. Apparently this item is utilized as food when it is available. The previously cited studies also reported the following as food items: frogs, snails, clams, insects, leeches, earthworms, and carrion. Generally, these miscellaneous records were few in frequency of occurrence and in volumetric composition.

Fish that were found in the stomachs were of three types: 1) speckled perch, or black crappie (*Pomoxis nigromaculatus*), 2) catfish (one *Ictalurus catus* and several *Ameiurus nebulosus* were identified), and 3) unidentifiable fish remains. The two identifiable species, speckled perch and catfish, were found together in only one stomach. The speckled perch were more common from the March collections to early June, when the catfish became more numerous. This apparent trend does not correlate with changes in size or number of the two types in the lake. Collections with the otter trawl and bag seine yielded relatively constant numbers and sizes of both speckled perch and catfish. Reconstructions of the total lengths of ingested speckled perch furnished a size range of about 4 to 8 inches; of catfish, 2.5 to 6.5 inches. Each of these was present in 27 of the stomachs. Collectively, the identifiable speckled perch and catfish were found in 53 of the stomachs that were not empty.

Forbes and Richardson reported minnows and buffalo fish in the stomachs of their 21 specimens. Scott listed six different identifiable genera (including catfish) from 71 stomachs; Lagler and Hubbs, 13 genera (including catfish, speckled perch, and gizzard shad) from 131 stomachs; Lagler and Applegate, 11 genera from 73 stomachs. Unpublished records of the Florida Game and Fresh Water Fish Commission of mudfish stomach analyses conducted at Lake Okeechobee show that 11 genera were found in 137 stomachs containing food (including speckled perch in 37 stomachs, catfish in 11, and gizzard shad in 28). It is my opinion that the selectivity of the diet of the mudfish in Lake Newnan,

expressed by the finding of only two identifiable species of fish in the stomachs examined, is an atypical expression of its food habits. The main causes of this selectivity are probably the lack of competition pressure among piscivorous species (suggested by population sampling) and a correlation of the activities of the speckled perch and catfish with the feeding habits of the mudfish.

The majority of authors making recommendations regarding control of the mudfish describe it as a noxious, voracious predator and suggest its removal (Forbes and Richardson, Scott, Black, 1954, Dequine, 1952, *et. al.*). It is apparent, however, that: if another species constituted a greater problem to fish management (as the gizzard shad in Lake Newnan); if the predatory habits of the mudfish effected a control upon this species; and if this control were not overbalanced through competition with desirable species, then the mudfish should not be removed. Haul seine reports for Lake Newnan from October, 1953, to October, 1954, listed the following approximate percentage composition by weight: mudfish, 0.8%; speckled perch, 5%; gizzard shad, 84%. Although tremendous numbers of gizzard shad small enough for the mudfish to feed upon were present in the lake, none were identified from the stomachs examined. This indicates that the mudfish effects no control on the shad population; and, since it preys upon a desirable pan fish, the speckled perch, and is generally a detriment to fishing, its removal seems warranted during the course of current seining activities. The undesirable attributes of the mudfish in Lake Newnan are not excessive enough, however, to require control measures strictly in its own behalf at this time.

Lack of information on the rate of digestion of stomach contents was acknowledged as being the possible cause of misinterpretation of the results due to either of two factors: 1) since an average of three hours elapsed from the laying out of the haul seine to the dip-netting of the catch, the mudfish could presumably feed unnaturally upon the many smaller fish enclosed; 2) if digestion were rapid, stomach contents might be enormously reduced from the time of cessation of feeding to preservation. The degrees of digestion of the contents were recorded as: slight, represented by erosion of the skin of catfish and dislocation of fin rays of centrarchids, and moderate, advanced, and unidentifiable, all representing increasingly more advanced stages of digestion.

In November, three mudfish were imprisoned in a 5 x 7 ft. wire cage in the lake. After several days a live speckled perch was forced into the stomach of one, a catfish into each of the other two. The mudfish were taken from the water after three hours, and the stomachs were put in formalin. On laboratory comparison, all three fish that had been force-fed to the mudfish showed less effects of digestive action than any of the fish contained in stomachs obtained from the haul seine. This suggests that digestive action is relatively slow, at least during the first three hours after feeding, and that all fish contents taken from the stomachs of mudfish captured in the haul seine represent those taken in the course of natural feeding. The possibility that these suggestions are valid warrants further experimentation to determine seasonal, psychological, and other influencing factors.

All but three of the 102 stomachs examined (including the three caged specimens) were heavily infested with an unidentified species of tape worm. This is a higher infestation than found by Bangham (1945) in which only 15 of 21 mudfish from other Florida waters contained tapeworm. Scott reported a 20% infestation in Indiana mudfish. The three stomachs that were uninfested were empty. The intestine of one of the uninfested specimens contained a trot line hook embedded near the pylorus with twelve inches of attached line extending out through the anus.

CONCLUSIONS

Comparison of the results of this study with those of other workers show that fish comprise the major portion of the diet of the mudfish. The selectivity of its diet in Lake Newnan is evidently an atypical case, probably governed by the nature of the composition of the present fish population of the lake. Absence of gizzard shad and the presence of speckled perch in the contents show that its feeding activities do not conform to current fish management concepts; consequently, its removal is recommended. The reliability of the results obtained from the haul seine seems plausible in view of the brief experiment conducted on the rate of digestion.

BIBLIOGRAPHY

BANGHAM, RALPH V.

1941. Parasites of fresh-water fish of Southern Florida. Proc. Fla. Acad. Sci., 5(4): 289-307.

BLACK, JOHN D.

1954. Biological Conservation. Blakiston Co., Inc., p. 138.

DEQUINE, JOHN F.

1952. Florida's controlled seining program. Fla. Game and Freshwater Fish Comm., Fish Mgmt. Bul. No. 1: 1-39.

FORBES, S. A., and R. E. RICHARDSON

1920. Fishes of Illinois. Ill. Nat. Hist. Ser., Vol. 3, Ichthyology, pp. 38-41.

LAGLER, K. F., and FRANCES V. HUBBS

1940. Food of the long-nosed gar (*Lepisosteus osseus oxyurus*) and the bowfin (*Amia calva*) in Southern Michigan. Copeia, No. 4: 239-241.

LAGLER, K. F., and V. C. APPLGATE

1942. Further studies on the food of the bowfin (*Amia calva*) in Southern Michigan, with notes on the inadvisability of using trapped fish in food analyses. Copeia, No. 3: 190-191.

SCHNEBERGER, E.

1937. The food of small dogfish (*Amia calva*). Copeia, No. 1: 61.

SCOTT, WILL

1938. The food of *Amia* and *Lepisosteus*. Invest. Ind. Lakes and Streams, 1(9): 110-115.

TWENTIETH ANNIVERSARY

This is the twentieth year of the Florida Academy of Sciences. At its annual meeting this year on the campus of the University of Miami the Academy will celebrate founders' day, honoring its charter members. At such a time as this one may like to glance back over a roster of some of those who have carried on the work of the Academy. The following is a list of the Academy's twenty presidents, six Secretary-Treasurers, and six Editors. Asterisks indicate charter members.

PRESIDENTS

- 1936 Herman Kurz,* Botany, Florida State University
- 1937 H. Harold Hume,* Agriculture, University of Florida
- 1938 R. I. Allen,* Physics, Stetson University
- 1939 Bernhard Paul Reinsch,* Mathematics, Florida Southern College
- 1940 Robert C. Williamson,* Physics, University of Florida
- 1941 Jay F. W. Pearson,* Zoology, University of Miami
- 1942 Raymond F. Bellamy,* Sociology, Florida State University
- 1943 Robert B. Campbell, Geology, Route 3, Box 573, Ft. Myers
- 1944 Lucien Y. Dyrenforth,* Pathology, Jacksonville
- 1945 Frances L. West,* Biology, St. Petersburg Junior College
- 1946 Guy G. Becknell,* Physics, University of Tampa
- 1947 E. Morton Miller,* Zoology, University of Miami
- 1948 George F. Weber,* Plant Pathology, University of Florida
- 1949 John E. Hawkins,* Chemistry, University of Florida
- 1950 H. Horton Sheldon, Industrial Engineering, (then) University of Miami
- 1951 Taylor R. Alexander, Botany, University of Miami
- 1952 Albert M. Winchester, Biology, Stetson University
- 1953 Chester S. Nielsen, Botany, Florida State University
- 1954 Sigismond deR. Diettrich, Geography, University of Florida
- 1955 Joseph Curtis Moore, Biology, Everglades National Park

SECRETARIES

- 1936 - 1942 J. H. Kusner,* Mathematics, University of Florida
- 1943 - 1945 Raymond F. Bellamy,* Sociology, Florida State University
- 1945 - 1947 Taylor R. Alexander, Botany, University of Miami
- 1947 - 1949 Chester S. Nielsen, Botany, Florida State University
- 1949 A. C. Higginbotham, Physiology, Florida State University
- 1950 - 1951 Chester S. Nielsen, Botany, Florida State University
- 1952 - 1955 Richard A. Edwards, Geology, University of Florida

EDITORS

- 1936 Theodore H. Hubbell,* Biology, (then) University of Florida
- 1937 H. Harold Hume,* Agriculture, University of Florida
- 1938 - 1943 Lucien Y. Dyrenforth,* Pathology, Jacksonville
- 1943 - 1945 Theodore H. Hubbell,* Biology, (then) University of Florida
- 1945 - 1948 Frank N. Young, Biology, (then) University of Florida
- 1948 - 1954 Howard K. Wallace,* Biology, University of Florida
- 1955 Joshua C. Dickinson, Biology, University of Florida

INSTRUCTIONS FOR AUTHORS

Contributions to the JOURNAL may be in any of the fields of Sciences, by any member of the Academy. Contributions from non-members may be accepted by the Editors when the scope of the paper or the nature of the contents warrants acceptance in their opinion. Acceptance of papers will be determined by the amount and character of new information and the form in which it is presented. Articles must not duplicate, in any substantial way, material that is published elsewhere. Articles of excessive length, and those containing tabular material and/or engravings can be published only with the cooperation of the author. Manuscripts are examined by members of the Editorial Board or other competent critics.

MANUSCRIPT FORM.—(1) Typewrite material, using one side of paper only; (2) double space *all* material and leave liberal margins; (3) use 8½ x 11 inch paper of standard weight; (4) do not submit carbon copies; (5) place tables on separate pages; (6) footnotes should be avoided whenever possible; (7) titles should be short; (8) method of citation and bibliographic style must conform to JOURNAL style—see Volume 16, No. 1 and later issues; (9) a factual summary is recommended for longer papers.

ILLUSTRATIONS.—Photographs should be glossy prints of good contrast. All drawings should be made with India ink; plan linework and lettering for at least ½ reduction. Do not mark on the back of any photographs. Do not use typewritten legends on the face of drawings. Legends for charts, drawings, photographs, etc., should be provided on separate sheets. Articles dealing with physics, chemistry, mathematics and allied fields which contain equations and formulae requiring special treatment should include India ink drawings suitable for insertion in the JOURNAL.

PROOF.—Galley proof should be corrected and returned promptly. The original manuscript should be returned with galley proof. *Changes* in galley proof will be billed to the author. Unless specially requested page proof will not be sent to the author. *Abstracts* and *orders for reprints* should be sent to the editor along with corrected galley proof.

REPRINTS.—Reprints should be ordered when galley proof is returned. An order blank for this purpose accompanies the galley proof. The JOURNAL does not furnish any free reprints to the author. Payment for reprints will be made by the author directly to the printer.

50673
F6F62

Quarterly Journal

of the

Florida Academy of Sciences

Vol. 18

June, 1955

No. 2

Contents

Caldwell—Notes on the Distribution, Spawning, and Growth of the Spot-tailed Pinfish, <i>Diplodus holbrooki</i>	73
Nielsen—Florida Oscillatoriaceae III	84
Hargis—Monogenetic Trematodes of Gulf of Mexico Fishes. Part VII	113
Hussey—Some Records of Hemiptera New to Florida	120
Smith and Vatsia—Effect of a Long Shaft on the Polarization of Skylight	123
Book Review	125
Organization for 1955 Annual Meeting	128



VOL. 18

JUNE, 1955

No. 2

QUARTERLY JOURNAL OF
THE FLORIDA ACADEMY OF SCIENCES

A Journal of Scientific Investigation and Research

Editor—J. C. DICKINSON, JR.

Associate Editor—JOHN D. KILBY

Published by the Florida Academy of Sciences

Printed by the Pepper Printing Co., Gainesville, Fla.

The business offices of the JOURNAL are centralized at the University of Florida, Gainesville, Florida. Communications for the editor and all manuscripts should be addressed to the Editor, Department of Biology. Business communications should be addressed to R. A. Edwards, *Secretary-Treasurer*, Department of Geology. All exchanges and communications regarding exchanges should be addressed to The Gift and Exchange Section, University of Florida Libraries.

Subscription price, Five Dollars a year

Mailed September 9, 1955

THE QUARTERLY JOURNAL OF THE FLORIDA ACADEMY OF SCIENCES

VOL. 18

JUNE, 1955

No. 2

NOTES ON THE DISTRIBUTION, SPAWNING, AND GROWTH OF THE SPOT-TAILED PINFISH, *DIPLODUS HOLBROOKI*

DAVID K. CALDWELL
University of Florida

Other than brief notes by Reid (1954: 46), almost nothing has been published heretofore concerning the biology of the Spot-tailed Pinfish, *Diplodus holbrooki*.

Intensive field work, primarily concerned with a study of the biology of another member of the family Sparidae, *Lagodon rhomboides*, was started in February, 1953, at Cedar Key, Levy County, Florida. Regular trips to this area continued through May, 1954, and sporadic trips have been continued to this writing, May, 1955. As a consequence, data have now been collected which constitute a contribution to the biology of *D. holbrooki* in that and adjacent regions. During the regular sampling period, 24 collecting trips were made to Cedar Key, with several regular collecting stations being made on each trip.

GEOGRAPHICAL DISTRIBUTION

The range of this species is generally considered to extend from Chesapeake Bay at Cape Charles City, Virginia (Hildebrand and Schroeder, 1928: 268), southward along the Atlantic coast, through the Florida Keys, and thence northward to Cedar Key on the Florida Gulf coast. It has been recorded from the Tortugas by Longley and Hildebrand (1941: 133) and by Jordan and Thompson (1905: 243). Eigenmann and Hughes (1887: 72), although they note the range on the Gulf coast of Florida as extending to Cedar Key, state that specimens of this species were examined by them from Pensacola, Florida. Joseph (1952) does not include *D. holbrooki* in his list of the fishes of the Alligator Harbor (Franklin County) region of

SEP 2 0 1955

Florida, although Dr. Ralph W. Yerger of Florida State University states (personal conversation) that this species is caught on rare occasions in Gulf waters several miles off Alligator Harbor. Reid (*loc. cit.*) indicates that it is not common at Cedar Key, reporting it only in small numbers during May and from September through November. I found that while *D. holbrooki* was not abundant at Cedar Key, it nevertheless occurred there in some numbers during most of the year. This species has been reported twice in offshore trawling operations by the M/V OREGON, exploratory fishing vessel operated by the United States Fish and Wildlife Service. It was taken on July 14, 1952, in 4½ fathoms at 29° 29' N., 83° 33' W. (roughly off the mouth of the Suwannee River), and again on March 11, 1954, in 15 fathoms at 28° 21' N., 83° 38' W. (about 60 miles south of the above locality).

Other writers are probably correct in stating that Cedar Key is the northern end of the normal range of *D. holbrooki* on the Gulf coast, though it is apparently at least an occasional visitor much farther to the north and west on that coast.

AREAS STUDIED AT CEDAR KEY

Most habitats of the Cedar Key area have already been described in previous studies of the fish of that locality. The "bay" (that area extending from the outer islands shoreward to the marshes) was described by Reid (*op. cit.*: 3) and by Moody (1950: 151), the "marsh" by Kilby (1955: 178). It should suffice, therefore, to give only a brief description of two previously undescribed Cedar Key stations, one of which was regularly visited, and the other sporadically sampled. The terminology for other habitat types used in this paper is that of the above writers.

Edge of Channel.—The vegetation of this station near Seahorse Key consisted primarily of various forms of algae (mostly brown). This predominance persisted during the entire year, with a slight reduction in abundance during the early spring. Some manatee (*Cymodocea*) and turtle (*Thalassia*) grass was present during the late spring and all summer months, though at no time did it outrank the algal covering. No slimy coating appeared on this vegetation as it had on that of the cove and shallow flat stations. The bottom material is primarily muddy sand. The depth normally varies from 3½ to 9 feet, with an average of about 4½ feet at mean

low tide. This habitat is very similar to the deep flats, except that it receives the stronger tidal sweep associated with the channels.

"*Pound Nets*".—A series of old pilings located some 12 miles from the town near the end of a long shallow sand bar known as Seahorse Reef. The clear water of the area, approximately 15 feet deep, is frequently visited by sport fishermen. The bottom is white sand, and the vegetation near the pilings consists of scattered patches of mixed algae, manatee grass, and turtle grass.

METHODS

A small (15-foot mouth) otter trawl, made of 1-inch-stretched mesh, and operated at a speed of approximately 3 mph from a small inboard motor boat, was used for sampling at all stations but the "pound nets". The net was dragged from 75 to 100 feet behind the boat, depending on the depth, and was on the bottom for 5 minutes on the flats and channel edge, and for 10 minutes in the channels. A 10- or 25-foot bag seine with $\frac{1}{2}$ -inch-stretched mesh was also used at a cove station during the warm months. During the winter this area was sampled with the trawl. The "pound net" specimens were taken by hook and line. It should be noted that the very young of other species were often caught in the trawl and seine, becoming tangled in vegetation and detritus. Thus it could be assumed that if the young, post-larval, stages of *D. holbrooki* were present, at least some would be caught with this type of gear.

Salinities were measured in the laboratory with a hydrometer. Most of the fish were preserved in the field in a 10% solution of formalin. Measurements are expressed in mm standard length, which is considered as being the uncurved length as measured by dividers from the tip of the snout to the base of the middle rays of the caudal fin.

Most of the specimens studied are deposited in the University of Florida fish collection.

HABITAT DISTRIBUTION AND SEASONAL MOVEMENTS

Reid (*op. cit.*: 46) reports finding *D. holbrooki* at Cedar Key only on deep flats. His specimens collected in May on a sandy-mud bottom with only sparse vegetation ranged from 29 to 39 mm in

length and were taken at a mean temperature of 24.5° C., and a mean salinity of 25.2 ppt. His fall specimens ranged from 56 to 90 mm in length. The surface temperature during this period ranged from 15.5°C. to 22.9°C., while the surface salinity was found to be from 9.7 to 28.6 ppt. My own findings show that a salinity as low as 9.7 ppt. is very exceptional in the "bay" and is usually the result of periods of heavy rainfall, causing a large discharge of fresh water into the "bay" by the Suwannee and Wacassassa Rivers, the mouths of which delimit the "bay" on the north and south respectively. A salinity ranging from 24 to 30 ppt. is generally to be expected in the "bay". The *D. holbrooki* which I collected were taken when surface temperatures ranged from 17.5°C. to 32.5°C., and surface salinities ranged from 24.4 to 31.0 ppt. Kilby (1955) in his study of the "marsh" fishes of the Cedar Key and Bayport areas did not collect this species. Other workers give only brief comments on its habitat. Hildebrand and Schroeder (*loc. cit.*) state that it is "frequently seen along breakwaters and piers on the coast of North Carolina". Longley and Hildebrand (*loc. cit.*) note that "small schools may usually be found along the rocky shore" and "on a bank in the upper of the deep holes in the flats within Bird Key reef". They further state that this species is "rarely found in small numbers about coral stacks on the reef". Jordan and Evermann (1908:443) note that "the young swarm about the wharves" at Beaufort, North Carolina. Dr. John D. Kilby of the University of Florida tells me that he observed one *D. holbrooki* (approximately 6 inches in length) in Salt Spring, Hernando County, Florida, on July 3, 1947. This spring is located approximately 1½ miles inland from the mouth of the Mud River where it flows into the Gulf of Mexico at Bayport. While Dr. Kilby made no salinity determination at that time, data he collected on four other trips to this spring (in September and October, 1948) resulted in a constant salinity of 1.8 ppt., though he states that he does not believe the spring water is always of this salinity, but fluctuates with the amount of rainfall. Herald and Strickland (1949: 99) did not include *D. holbrooki* in their list of the fishes of Homosassa Springs, Citrus County, Florida, nor have I heard of any instances of its occurrence in similar freshwater and brackish-water springs and rivers which afford free access to salt water, and which often contain typically marine fish species. The OREGON records show that this species does occur, at least occasionally, in deeper waters—

down to at least 90 feet. All of the above situations seem to indicate, therefore, that *D. holbrooki* inhabits open waters of relatively high salinity, occurring only rarely in brackish waters, and probably not at all in true fresh waters. As will be noted below, my own collections at Cedar Key seem to substantiate this conclusion. Nearly all of my specimens were taken on open, shallow or deep flats, on a channel edge, or about the "pound nets". No specimens were collected at a cove station or in the channel within the "bay", and they were taken in a channel outside the "bay" on only one occasion. The data also indicate that when in the bays and shallower open Gulf waters a preference is shown for a vegetated bottom, perhaps since the vegetation supports abundant invertebrate forms which seem to constitute the bulk of the food of this species.

Distribution of the O-year Class.—The smallest specimens collected (17 mm) were taken on a shallow flat in March. The O-year class specimens taken in April were also from the same shallow flat. Specimens of this class then appeared on the channel edge in May and continued to be taken on the shallow flat. The class first appeared on a deep flat in June and continued to appear here, on the shallow flat, and on the channel edge through October. Only two examples (75 and 80 mm) were taken in November, on the channel edge. In each month that specimens were taken in more than one of these three habitats, the size range between habitats did not vary to a significant degree, and thus the general size range of the O-year class found in each habitat for a given month can be determined from Figure 1. Seasonal abundance varied somewhat with the three habitats. In general, *D. holbrooki* was most abundant on shallow flats during the spring and summer (through August), moving into the deeper water of the deep flats and the channel edge with the onset of fall and early winter, and finally disappearing completely from the flats and channel edge in winter. The only specimens collected in the channel were taken in late February, 1954, in an area outside the limits of the "bay", and possibly were just moving back into the shallower waters of the "bay" with the onset of spring; none had been taken there during the winter. The apparent winter offshore migration is suggested in Figure 1, in which the same general range of length-frequency groups appears for the O-year class in the fall. This

may of course be due to a slow-down of growth with the colder fall weather, but it can also probably at least be partially explained as an offshore movement (and thus out of sampling range) of the older members of the age group, leaving the smaller fish to reach a size required for the migration. Specimens collected on Seahorse Reef near the "pound nets" (but not among the pilings) in April and May of 1954 (Figure 1) are apparently members of his O-year class. None of these year-old fish were taken in "bay" waters, though a similar sized example (91 mm) was collected on a shallow flat in April, 1953.

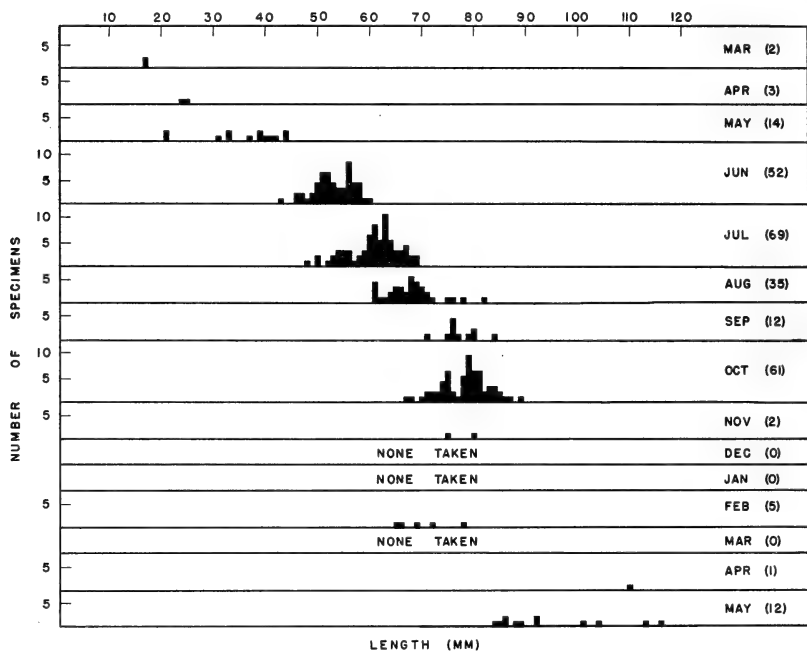

Fig. 1. Standard length-frequency data for the O-year class of *Diplodus holbrooki* at Cedar Key, Florida, during 1953 and early 1954. Numbers of specimens are indicated in parentheses.

Distribution of Older Year Classes.—Specimens of older age groups (91 or more mm in the spring), were taken primarily offshore, at the "pound nets", though occasional specimens were taken on the shallow and deep flats and on the channel edge throughout the spring, summer, and fall months. This older age group disappeared from the "bay" during the winter as did the O-year class,

and it probably disappears for the most part from the "pound nets" as well, though that area is not usually fished in winter due to generally rough weather, and some may remain. Dr. E. Lowe Pierce of the University of Florida stated that on March 26, 1953, large *D. holbrooki* were fairly abundant at the "pound nets" and that they had not been seen there a week earlier. Mr. Leonard Giovannoli, also of the University of Florida, stated that on May 8, 1954, he caught numerous *D. holbrooki* at the "pound nets" and that in general one size group (130 to 156 mm) was taken among the pilings, and that a smaller size group (84 to 113 mm) was caught on the edge of Seahorse Reef near the "pound nets", but away from the pilings.

SPAWNING

Apparently only one definite statement has been made heretofore with regard to the spawning of this species. Reid (*op. cit.*: 47) notes that the size of the individuals he collected in May "would indicate a spring breeding . . .". He also states that he collected one specimen in which the gonads were developed but not mature. Although he states that his individual was 90 mm long, he does not state the month in which it was collected, though it was apparently one of the specimens collected in the fall. My own findings seem to disagree slightly with those of Reid in respect to the time of spawning. My 17 mm specimens were collected on March 28, and were probably little more than two months old (interpolating Figure 2) at the time of capture. Though this must remain an estimate for the time being, it would appear that spawning must take place during late December, in January, or in February. The young of *D. holbrooki* smaller than 17 mm are apparently undescribed. The larger, spawning sizes, vitrually disappear from the inshore waters during the winter season, and it is assumed that spawning takes place at some point far enough offshore to enable the young fish to reach 17 mm length before appearing in the inshore collections, and still not so far that they reach a much larger size before appearing. The presence of early young for such a short time, and the rather narrow range of lengths for the O-year class throughout the summer, indicate that the spawning season is rather short and probably does not last more than two months.

The only pre-spawning season adults (129-153 mm) which were collected were taken during the months of October and November.

The gonads of these fish showed considerable development, with the sexes easily distinguishable. It is unfortunate that specimens were not available during the months of December through March for similar examination (see distribution of the older year classes under HABITAT), though Mr. Charles Crevasse, Sr., a long-time fisherman-resident of Cedar Key, tells me that in earlier years he has seen specimens that appeared to be fully ripe later in the winter than the dates on which my latest specimens were taken.

Some adult fish (130 mm or more) collected at the "pound nets" early in April and in May, 1954, showed a spent gonadal condition, while others had gonads showing definite signs of recovery and beginning development for the next fall-winter spawning season.

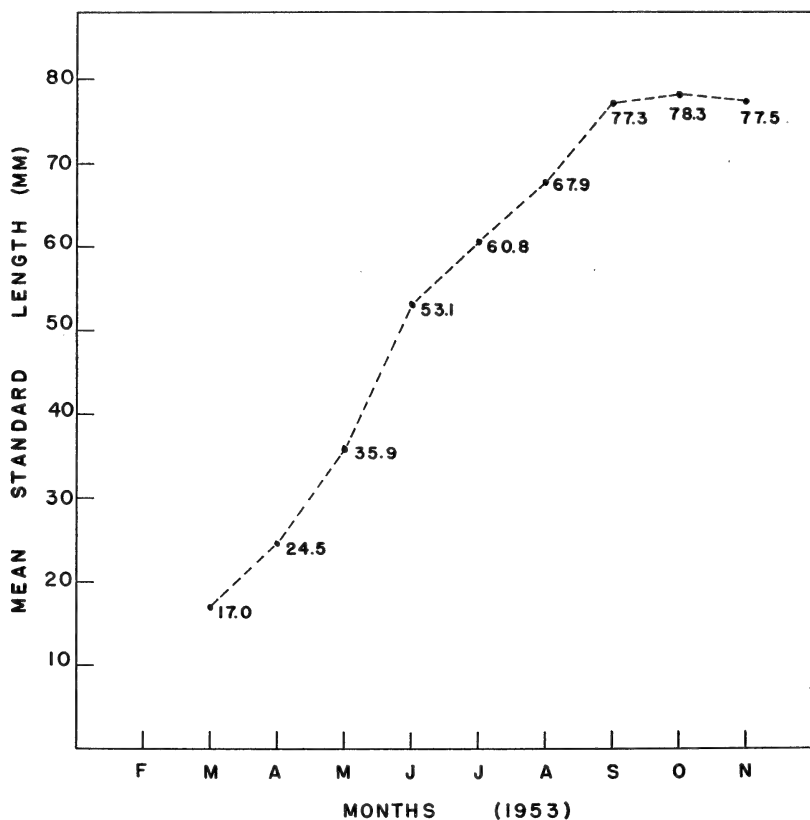

Fig. 2. Growth rate for the O-year class of *Diplodus holbrooki* at Cedar Key, Florida, during 1953. The mean standard length for each month is indicated at each point on the curve.

This latter condition was particularly true of the late May specimens.

Reid's 90 mm specimen was probably in its first year (see fall size ranges, Figure 1). Though I found no evidence of gonadal development in members of the O-year class in the fall of 1953 which would indicate their spawning that coming winter, I did find members of this age group with partially developed gonads when they returned the following spring (May specimens, Figure 1). This development was probably not a condition of recovery after spawning, but one of initial development in preparation for a first spawning, in the coming season. The two conditions are easily confused. Data are sufficient to indicate that only fish 129 mm or over were spawning, and that these fish were undoubtedly in at least their second winter after hatching.

GROWTH RATE

Apparently nothing has been published heretofore concerning the growth rate of *D. holbrooki*. Length-frequency graphs have been prepared for the 1953 O-year class (believed to have been spawned the previous winter of 1952-53). These are summarized in Figure 1. The growth rate for this year class is obviously very rapid, the fish increasing some 60 mm in 6 months. The mean for each month has been calculated and the resulting growth curve drawn, appearing as Figure 2. A typical sigmoid growth curve is shown, with the period of most rapid increase being observed to occur during the early summer months. The leveling off shown in Figures 1 and 2 after September is probably due to two factors already discussed: the expected slow-down of growth with the onset of cold weather, and the offshore movement. When this year class reappears in February, 1954 (Figure 1), it can be seen that there has been no apparent growth during the winter. However, by April and May growth has occurred apparently at a rate comparable with this class during the previous summer.

The fall fish shown in Figure 1 show a slightly larger mean size for any given month than do those collected in the fall of 1950 by Reid (whose specimens, now in the University of Florida fish collection, were measured by me). This may be due to a slightly later time of spawning during the winter period just before his sampling or to varying conditions between the two collecting

periods resulting in a slightly slower growth rate during 1950. His sample of May individuals from the following year (1951) agrees in size much more closely with the samples I collected.

ACKNOWLEDGMENTS

I acknowledge with thanks Dr. John D. Kilby for his Salt Spring data; Dr. E. Lowe Pierce and Mr. Leonard Giovannoli for their comments and for adult specimens; Mr. Stewart Springer for the OREGON records; and Mr. Charles Crevasse, Sr., for his comments on spawning season. I also wish to thank the many people who assisted me in the field, especially Messrs. Frederick H. Berry, Jr., Jerome O. Krivanek, and Dale W. Rice.

LITERATURE CITED

EIGENMANN, CARL H., and ELIZABETH G. HUGHES

1887. A review of the North American species of the genera *Lagodon*, *Archosargus*, and *Diplodus*. *Proc. U. S. Nat. Mus.*, 10: 65-74.

HERALD, EARL S. and ROY R. STRICKLAND

1949. Annotated list of the fishes of Homosassa Springs, Florida. *Quart. Jour. Fla. Acad. Sci.*, 11 (4): 99-109.

HILDEBRAND, SAMUEL F., and WILLIAM C. SCHROEDER

1928. The fishes of Chesapeake Bay. *Bull. U. S. Bur. Fish.*, 43 (part 1): 1-366.

JORDAN, DAVID S., and BARTON W. EVERMANN

1908. *American Food and Game Fishes*. Doubleday, Page & Co., New York. pp. i-xx, 1-572.

JORDAN, DAVID S., and JOSEPH C. THOMPSON

1905. The fish fauna of the Tortugas archipelago. *Bull. U. S. Bur. Fish.*, 24 (1904): 229-256.

JOSEPH, EDWIN S.

1952. The fishes of Alligator Harbor, Florida, with notes on their natural history. Ms. (unpub.). Thesis presented to Florida State University, December, 1952.

KILBY, JOHN D.

1955. The fishes of two gulf coastal marsh areas of Florida. *Tulane Stud. Zool.*, 2(8): 175-247.

LONGLEY, WILLIAM H., and SAMUEL F. HILDEBRAND

1941. Systematic catalog of the fishes of Tortugas, Florida. *Pap. Tortugas Lab.*, Carnegie Inst. of Wash., 34: xii + 331 pp.

MOODY, WILLIAM D.

1950. A study of the natural history of the spotted trout, *Cynoscion nebulosus*, in the Cedar Key, Florida, area. *Quart. Jour. Fla. Acad. Sci.*, 12(3), 1949 (1950): 147-171.

REID, GEORGE K., JR.

1954. An ecological study of the Gulf of Mexico fishes, in the vicinity of Cedar Key, Florida. *Bull. Mar. Sci. of the Gulf and Carib.*, 4(1): 1-94.

FLORIDA OSCILLATORIACEAE III ¹

C. S. NIELSEN

Florida State University

Studies of the species of Oscillatoriaceae found in and reported for Florida which are characterized by a multitrichomate development have been reported in a previous publication (Nielsen 1954 B). The unitrichomate species which do not develop recognizable sheaths and are included in the genera *Oscillatoria*, *Spirulina* and *Arthrospira* were the subject of the first in this series of three reports (Nielsen 1954 A). The present paper deals with the remaining members of this family of the Cyanophyta known from the state.

The collections cited include not only those of the Botany faculty and students of the Florida State University, but also those of the late Dr. Melvin A. Brannon in the Gainesville area, the early collections of J. Donnell Smith as reported in Wolle, Fresh Water Algae of the United States and Tilden, Minnesota Algae I, and numerous others made in the intervening years. The following abbreviations are used to designate the location of the specimens: C, cryptogamic herbarium of the Chicago Natural History Museum; D, personal herbarium of Dr. Francis Drouet; F, herbarium of the Florida State University; H, Farlow Herbarium, Harvard University and P, University of Pennsylvania Herbarium.

Acknowledgment of indebtedness to the many individuals whose names appear with the citation of their collections, and of the invaluable assistance of Dr. Francis Drouet of the Chicago Natural History Museum for determinations and guidance is most gratefully recorded.

GENERA OF THE LYNGBYEAE

Subtribe 1. Lyngbyoideae. Filaments simple or pseudo-branched. Sheaths firm, in several species dark yellow. Trichomes consistently straight to apex.

- a. Filaments free, pseudo-branched, pseudo-branches often geminate 1. *Plectonema*
- b. Filaments ascending from repent bases and joined fasciculate; generally pseudo-branched, pseudo branches solitary 2. *Symploca*

¹ Contribution number 67, Botanical Laboratory, Florida State University.

- c. Filaments simple, free, entangled into a floccose or pan-nose stratum, especially caespitose 3. *Lyngbya*

Subtribe 2. Oscillarioideae. Filaments simple. Sheaths thin, always hyaline, mucous, more or less diffuent, absent in many species or not apparent. Trichomes in some species curving toward apex.

- d. Sheaths agglutinated in part or entirely, never separating without rupture 4. *Phormidium*
- e. Trichomes cylindrical, non-sheathed, aggregated into squamuliform (small scale-like) free-floating fascicles 5. *Skujaella*

The genera, *Oscillatoria*, *Arthrospira*, *Spirulina*, and *Borzia* are generally included in the Oscillarioideae; the first three have been treated in a previous paper (Nielsen 1954 A); the genus *Borzia* is not represented among known Florida collections.

1. *Plectonema* Thuret

Filaments sheathed, free, pseudo-branches arising from side of trichome, pseudo-branches solitary or geminate. Sheaths firm, hyaline, rarely yellow-gold. Trichomes frequently constricted at cross-walls; apex of trichome straight, most rarely attenuate; calyptra absent.

Plants scytonematoid, often caespitose and hydrophilic.

- A. Plants larger, caespitose. Trichomes 3 microns or more wide.
1. Plants very large, indefinite, black, rarely yellow-green. Trichomes never torulose, 28-47 microns wide 1. *P. Wollei*
 2. Tufts indefinite, blackish-purple. Trichomes exceedingly torulose, 3 microns wide 2. *P. purpureum*
- AA. Plant very small, never caespitose. Trichomes 1-2 microns wide.
1. Often with various gelatinous algae. Filaments almost straight. Trichomes pale yellow-green, torulose. Cells longer than diameter 3. *P. Nostocorum*
 2. Filaments subflexuous, on old shells. Trichomes light blue-green, not torulose 4. *P. terebrans*

3. Filaments tortuous. Trichomes light blue-green, not torulose 5. *P. norvegicum*

AAA. Plants intermediate in size. Trichomes 2 - 2.5 microns wide 6. *P. calothrichoides*

1. *Plectonema Wollei* Gomont. Monogr. Oscill. Ann. Sci. Nat. Bot. VII 16: p. 98, pl. 1, f. 1 (1892).

Plants caespitose, waving, with many bases, black to rarely pale yellow-green. Filaments woolly, intricate, fragile (in dried specimens), nearly straight or diversely curved, sparingly pseudo-branched, pseudo-branches solitary, rarely geminate, arising obliquely. Sheaths hyaline, occasionally yellow-gold, with age becoming lamellose, rough along margins, up to 10 mic. wide, not turning blue with chlor-zinc-iodine. Trichomes dark blue-green, occasionally pale yellow-green, never constricted at cross-wall, 28-47 mic. wide; cell 4 to 9 times shorter than trichome diameter, 4-9 mic. long, filled with small protoplasmic granules, larger granules sometimes interspersed; cross-walls never granular; apical cell rotund.

Alachua county: in running stream from spring near Gainesville, *Ravenel* 30, Dec. 1877 (C, D, P). Citrus county: near Crystal River, *Paul O. Schallert* 2070 A, 12 Mar. 1949 (C, D). Jackson county: free-floating in ditch, 2 miles east of Marianna, roadside pk. on U. S. 90, *H. R. Wilson* 85, 28 July 1952 (C, D, F). Lake county: Harris lake, Leesburg, *M. A. Brannon* 329, 31 May 1948 (C, D). Marion county: in spring, Silver Springs, *G. Peek* 408, 25 Mar. 1941 (C, D); Rainbow Springs, *Brannon* 408, 8 Nov. 1945 (C, D); 381, 20 Oct. 1946 (C, D); 210, 1947 (C, D); Rainbow Springs on U. S. 41, 4 miles north of Dunnellon, *Madsen, Pates and Hood*, 1953, 1955, 27 Nov. 1949 (C, D, F). Orange county: Orlando, *Brannon* 334, 340, 343, 31 May 1948 (C, D); in rock spring, Kelly pk., *Schallert* 2278 A, 1 June 1951 (C, D). Wakulla county: in shallow water, south side of spring pool, Wakulla Springs, *Drouet, Madsen & Crowson* 11492, 27 Jan. 1949 (C, D, F).

2. *Plectonema purpureum* Gomont. Monogr. Oscill. Ann. Sci. Nat. Bot. VII, 16: p. 101, pl. 1, f. 7-8 (1892).

Tufts extended, indefinite, black-purple. Filaments intricate, exceedingly flexuous, abundantly pseudo-branched, pseudo-branches solitary or geminate. Sheaths hyaline, firm, somewhat thicker, not turning blue with chlor-zinc-iodine. Trichomes reddish, exceedingly constricted at cross-walls, apex never attenuate, 3 microns wide; cells subquadrate to 1/3 shorter than diameter, 1 - 2.3 microns long, protoplasm homogeneous; apical cell rotund above.

Alachua county: in bird bath, Hibiscus pk., Gainesville, *Brannon* 41, Feb. 1942 (C, D). Pinellas county: inside plastic garden hose, *Sylvia Earle* 311, 4 Apr. 1954 (C, D, F).

3. *Plectonema Nostocorum* Gomont. Monogr. Oscill. Ann. Sci. Nat. Bot. VII 16: p. 102, pl. 1, f. 11 (1892).

Filaments slender, elongate, nearly straight, at first repeated, with age producing pseudo-branches sparingly, pseudo-branches solitary or geminate. Sheaths hyaline, very thin, cylindrical, not turning blue with chlor-zinc-iodine. Trichomes pale yellow-green, constricted at cross-walls, 1 - 1.5 microns wide; cell longer than diameter, 2 - 2.5 microns long; cross-walls not granular; apical cell rotund.

Alachua county: in Sink I, Hibiscus pk., Gainesville, *A. B. Maclay* 28, 108, Nov. 1941 (C, D); Gainesville, *Brannon*, 1947 (C, D). Citrus county: Hernando, *Brannon*, 9 Dec. 1942 (C, D); 210, 15 Apr. 1944 (C, D); on wall of cave, near Lecanto, *Schallert* 2083 A, 12 Mar. 1949 (C, D). Collier county: dried pool, Marco island, *Paul C. Standley* 73389, 19 Mar. 1940 (C, D). Dade county: fresh-water, on rock, Long Pine Key, Everglades Nat. Pk., *L. B. Isham*, 9-17, 1952 (C, D). Escambia county: in depression in sand dunes, west of Gulf beach, *Drouet, Nielsen, Madsen & Crowson* 10565, 8 Jan. 1949 (C, D, F). Franklin county: shore of Alligator bay, east of Theresa, *Drouet & Nielsen* 11683, 31 Jan. 1949 (C, D, F). Gulf county: on rocks of retaining wall, 2 miles N.W. of Port St. Joe on U. S. 98, *Madsen, Pates, Hood & Elias* 1511, 31 July 1949 (C, D, F). Jackson county: on limestone walls of entrance to cave, Fla. Caverns state pk., 3 miles north of Marianna, *Drouet, Nielsen, Madsen & Crowson* 10397, 4 Jan. 1949 (C, D, F); bottom steps of cave entrance, Fla. Caverns state pk., *Nielsen* 1, 28 Aug. 1952 (C, D, F). Lake county: on pilings in pond at 14th & Center sts., Leesburg, *Drouet & Brannon* 11077, 19 Jan. 1949 (C, D). Leon county: on sand rock, Tallahassee, *Brannon* 2, 23, 102, Dec. 1940 (C, D); Botany dept. greenhouse, F.S.U. campus, *Nielsen* 57, 19 May 1948 (C, D, F); Meridian rd., *Nielsen & Madsen* 458, Aug. 1948 (C, D, F); Ochlockonee river, Lake Iamonia channel on Meridian rd., *Nielsen, Madsen & Crowson* 642, 31 Oct. 1948 (C, D, F); on road-bank in cypress swamp beside state highway no. 61, just north of Leon-Wakulla county line, *Drouet, Madsen & Crowson* 11535, 27 Jan. 1949 (C, D, F); partially submerged on limestone, edges of Ochlockonee river, Jackson Bluff, *C. Jackson*, 9 Nov. 1950 (C, D, F); F.S.U. greenhouse, Tallahassee, *Nielsen* 21, 4 Nov. 1952 (C, D, F).

Marion county: Orange Lake, McIntosh, *Brannon 614*, 21 Jan. 1949 (C, D). Monroe county: light gray, dried sink hole, west of inn, Big Pine Key, *E. P. Killip 41731*, 11 Jan. 1952 (C, D); bluish, Southwest Point, on white marl, Big Pine Key, *Killip 41795*, 19 Jan. 1952 (C, D); north end of key, east of bay, Big Pine Key, *Killip 41835*, 25 Jan. 1952 (C, D); green, on decayed vegetation and black mud, Buttonwood pool near east edge of pine-palm woods, N.E. of inn, Big Pine Key, *Killip 41932, 41933*, 15 Feb. 1952 (C, D). Okaloosa county: Santa Rosa sound, at west end of bridge on U. S. 98, Fort Walton, *Drouet, Nielsen, Madsen, Crowson & Pates 10646*, 9 Jan. 1949 (C, D, F). Palm Beach county: in sand walk in park by Flagler dr. at 3rd st. West Palm Beach, *Drouet & Louderback 10225*, 24 Dec. 1948 (C, D). Polk county: Exp. Station greenhouse, Lake Alfred, *Nielsen 453*, Aug. 1948 (C, D, F). Wakulla county: Light-house pool, St. Marks Wildlife Refuge, *Crowson 68*, May 1948 (C, D, F); Spillway dam at Phillips pool, St. Marks Wildlife Refuge, *Nielsen, Madsen & Crowson 521*, 9 Oct. 1948 (C, D, F); on bark of log, Log Spring, north of Newport, *Nielsen*, 23 July 1952 (C, D, F). Washington county: Falling Waters, 4 miles south of Chipley, on log over stream, *M. H. Voth*, 14 Jan. 1951 (C, D, F).

Specimens of the species were commonly found associated with the following: *Calothrix parietina* B. & F., *Coccochloris elabens* (Breb.) Dr. & Daily, *Fremyella diplosiphon* (B. & F.) Dr., *Lyngbya aestuarii* Gom., *L. putealis* Gom., *Oscillatoria amoena* Gom., *O. anguina* Gom., *Scenedesmus dimorphus* (Turp.) Kütz. and *Schizothrix purpurascens* Gom.

4. *Plectonema terebrans* Gomont. Monogr. Oscill. Ann. Sci. Nat. Bot. VII 16: p. 103 (1892).

Filaments slender, elongate, flexuous, generally sparingly pseudo-branched, pseudo-branches more often solitary. Sheaths hyaline, very thin, cylindrical, not turning blue with chlor-zinc-iodine. Trichomes light blue-green, not torulose, 0.95 - 1.5 microns wide; cells longer than diameter of trichome, 2.6 microns long; cross walls characterized by two protoplasmic granules; apical cell rotund.

Bay county: Hathaway bridge west of St. Andrew on U. S. 98, *Madsen, Pates, Hood & Elias 1941 A*, 11 Sept. 1949 (C, D, F); south end of Du Pont bridge, west of San Blas on U. S. 98, *Madsen, Pates, Hood & Elias 1943*, 11 Sept. 1949 (C, D, F). Dade county: culture of algae from Gulf stream near Miami Beach, *Reuben Lasker*, 21 Mar. 1951 (C, D). Franklin county: intertidal on shore of Apalachi-

cola bay in S.E. part of Apalachicola, *Drouet & Nielsen 11001*, 16 Jan. 1949 (C, D, F); intertidal on shoe of Apalachicola bay, west of limits of Apalachicola, *Drouet & Nielsen 11655*, 31 Jan. 1949 (C, D, F). Jackson county: 1 mile north of Marianna, under Chipola river bridge, submerged on limestone, *H. R. Wilson 1*, 28 July 1952 (C, D, F). Leon county: St. Marks river at Natural Bridge, *Nielsen, Madsen & Crowson 574, 575*, 30 Oct. 1948 (C, D, F). Monroe county: on rock, North Key Largo, *L. B. Isham 16*, 1952 (C, D); intertidal, North Key Largo, *R. N. Ginsberg*, 1952 (C, D); on beach rock from Dry Tortugas, west side of Loggerhead Key, *Ginsberg*, Apr. 1952 (C, D); on rock, Largo sound, Key Largo, *L. B. Isham 13*, 23 Nov. 1952 (C, D); Indian Key, *L. B. Isham 14*, 30 Nov. 1952 (C, D); in ditch along U. S. 1, 8 miles north of Key Largo, *D. Blake & R. Hauke 18*, 4 Feb. 1953 (C, D, F). Volusia county: on oyster shells, Halifax river, Daytona beach, *H. J. Humm 7*, 26 Feb. 1946 (C, D, F). Wakulla county: intertidal on shell in St. Marks river, Port Leon, *Drouet & E. M. Atwood 11462*, 26 Jan. 1949 (C, D, F); lighthouse jetty, St. Marks Wildlife Refuge, *Nielsen & Crowson 899*, May 1949 (C, D, F); on rock, brackish stream along main road, St. Marks Wildlife Refuge, *Nielsen 6*, 4 Oct. 1951 (C, D, F).

Specimens were found with: *Entophysalis deusta* (Menegh.) Dr. & Daily, *Hyella caespitosa* B. & F. and *Mastigocoleus testarum* B. & F.

5. *Plectonema norvegicum* Gomont. Bull. Soc. Bot. Fr. 46: p. 34 (1899).

Stratum crustaceous, dark to dark-green, hardening upon drying, never softening without crushing. Filaments slightly elongate, tortuous, abundantly pseudo-branched, pseudo-branches generally geminate, extended, short, of equal width from initial filament. Sheaths never attenuate, at first smooth, hyaline, later thick, eroded, yellow-dark, never turning blue with chlor-zinc-iodine. Trichomes light blue-green, torulose, submoniliform, 1.5-2 microns wide, short cells, cell length one-half the diameter; apical cell rotund.

Dade county: culture of algae from plankton from Gulf stream off Miami Beach, *Reuben Lasker*, 11 Apr. 1951 (C, D). Levy county: intertidal on pilings at east end of bridge on causeway from mainland to Way Key, Cedar Keys, *Drouet & Nielsen 11183*, 22 Jan. 1949 (C, D, F).

6. *Plectonema calothrichoides* Gomont. Bull. Soc. Bot. Fr. 46: p. 30, pl. 1, f. 6-10 (1899).

As a crust formed of various myxophycean algae. Filaments briefly elongate, intertwined into a dense ball, radiating with pressure, exceedingly

tortuous. Ends attenuate in a bilateral fashion and as though hairy, not at all infrequently pseudo-branched, pseudo-branches geminate, expanded, more often parallel. Sheaths in middle portion of filaments wide and darkish gold, toward extremes very gradually attenuate and discolored. Trichomes pale blue-green, torulose, submoniliform, 2 - 2.5 microns wide, short celled; cells to 1/3 diameter in length; apical cell rotund.

Collier county: Marco island, *Paul C. Standley* 92822, 14 Mar. 1946 (C, D). Duval county: pilings of pier 2 miles south of St. Johns river mouth, Jacksonville Beach, *H. J. Humm* 4, 19 Mar. 1948 (C, D). Flagler county: Marineland, Daytona Beach, *T. A. & Anne Stephenson*, 20 March 1947 (C, D). Franklin county: on paint from South Shoals Whistling Buoy No. 26, *Nielsen*, 4 July 1951 (C, D, F). Monroe county: Indian Key, *L. B. Isham* 20, 1952 (C, D); Cudjoe Key, *L. B. Isham* 23, 1 Oct. 1952 (C, D).

Specimens were found with the following species: *Calothrix pulvinata* B. & F., *C. scopulorum* B. & F., *Entophrysalis granulosa* Kütz., *E. deusta* (Menegh.) Dr. & Daily, *Microcoleus tenerrimus* Gom. and *Symploca atlantica* Gom.

2. *Symploca* Kützing

Filaments sheathed, at base prostrate, ascending and in erect fascicles or rarely more or less procumbent and densely joined and anastomosing, generally pseudo-branched, pseudo-branches solitary. Sheaths thin, hyaline, firm or submucous. Trichomes straight to apex, not attenuate (except *S. Kieneri* Dr.); membrane of apical cell slightly thickened above in some species. Plants terrestrial or aquatic, rarely halophilic.

A. Plants halophilic

1. Black-green. Fascicles erect. Trichomes 4-6 mic. wide, torulose throughout entire length 1. *S. atlantica*
2. Brilliant green. Fascicles appressed, slender, 1 mm. never longer. Trichomes 1.5 - 3.5 microns wide, exceedingly torulose 2. *S. laete-viridis*

B. Plants terrestrial or fresh-water

C.

C. Trichomes 3 microns or more wide

1. Fascicles elongate, generally repent, spiniform. Trichomes not torulose, 5 - 8 microns wide; cells subquadrate to longer than diameter 3. *S. Muscorum*

2. Fascicles short, erect, spiniform. Trichomes not torulose, 3.4 - 4 microns wide; cells subquadrate to twice as short as diameter 4. *S. muralis*
3. Fascicles erect or repent and parallel. Trichomes distinctly torulose, 4 - 10 microns wide; cells quadrate to twice trichome width. Sheaths thicker than *S. Muscorum* 5. *S. Kieneri*

CC. Trichomes less than 3 microns wide

1. Whitish-grey, fibrose-compact. Trichomes 1.5 - 2.5 microns wide, not torulose. Sheath turning blue with chlor-zinc-iodine 6. *S. dubia*

1. *Symploca altantica* Gomont. Monogr. Oscill. Ann. Sci. Nat. Bot. VII 16: p. 109, pl. 2, f. 5 (1892).

Fasciculate-caespitose, black-green. Fascicles erect, up to 1 cm. tall. Filaments most densely entangled or free, simple, uncinata and tortuous. Sheaths thin, firm, turning blue with chlor-zinc-iodine. Trichomes greenish-yellow, 4 - 6 microns wide, constricted at cross-walls throughout entire length; cells generally quadrate or shorter than diameter, very rarely longer, 2 - 6 microns long; protoplasm slightly granular; cross walls conspicuous, translucent, never granular; membrane of apical cells thickened above into depressed conical calyptra.

Bay county: intertidal on barnacles on pilings on shore of St. Andrews bay, Cove hotel, Panama City, *Drouet & Nielsen 11615*, 30 Jan. 1949 (C, D, F). Dade county: culture of algae from plankton in Gulf Stream off Miami Beach, *Reuben Lasker*, 28 Feb. 1951 (C, D). Duval county: pilings of pier 2 miles south of St. Johns river mouth, Jacksonville Beach, *H. J. Humm 4*, 19 Mar. 1948 (C, D, F). Franklin county: between tide limits at docks in New river, Carrabelle, *Drouet & Nielsen 10966*, 16 Jan. 1949 (C, D, F); on woodwork between tide limits, at docks in New river, Carrabelle, *Drouet & Nielsen 10967 A, 10969*, 16 Jan. 1949 (C, F, D); intertidal on bases of larger plants, shore of Apalachicola bay, southeast part of Apalachicola, *Drouet & Nielsen 10995, 10996, 11000, 11002*, 16 Jan. 1949 (C, D, F). Levy county: between tide marks on woodwork at municipal dock, Cedar Key, *Drouet & Nielsen 11115*, 22 Jan. 1949 (C, D, F). Manatee county: in depression on beach, west shore of Anna Maria island, *Cloyd B. Stifler*, 24 Dec. 1940 (C, D); in flower bed, Anna Maria island, *Stifler*, 25 Dec. 1940 (C, D). Taylor county: intertidal at confluence of Daughter creek and

Steinhatchee river, Steinhatchee, *Drouet & Nielsen 11217*, 23 Jan. 1949 (C, D, F).

The following species were found associated: *Calothrix pulvinata* B. & F., *Entophysalis deusta* (Menegh.) Dr. & Daily, *Microcoleus tenerrimus* Gom., *M. chthonoplastes* Gom., *Plectonema calothri-choides* Gom. and *Rhizoclonium riparium* (Roth.) Harv.

2. *Symploca laete-viridis* Gomont. Monogr. Oscill. Ann. Sci. Nat. Bot. VII 16: p. 109, pl. 2, f. 6-8 (1892).

Stratum thin, villose, brilliant green to yellowish. Fascicles slender, appressed to substratum, up to 1 mm. high. Filaments moderately flexuous, nearly parallel, agglutinated, simple. Sheaths full, submucous, turning blue with chlor-zinc-iodine. Trichomes brilliant green, 1.5 - 3.5 microns wide, very constricted at cross-walls; cells from a little shorter to twice as long as trichome diameter, 2.5 - 6 microns long; protoplasm never granular; apical cell conical; calyptra absent.

Escambia county: intertidal on shore of bayou near Fort Barranca, *Drouet, Nielsen, Madsen & Crowson 10549*, 8 Jan. 1949 (C, D, F). Monroe county: Key West, Gulf of Mexico, *Farlow* (H); Tea Table Key, black zone, *L. B. Isham 1*, 1 July 1952 (C, D); West Summerland Key, *L. B. Isham 25*, Oct. 1952 (C, D); Indian Key, *L. B. Isham 27*, 1 Oct. 1952 (C, D). Volusia county: Marineland, Daytona Beach, *T. A. & Anne Stephenson*, 20 Mar. 1947 (C, D). Wakulla county: intertidal stones on east shore of East river, west of St. Marks lighthouse, on Gulf of Mexico at mouth of St. Marks river, *Drouet, Madsen & Crowson 11735 A*, 1 Feb. 1949 (C, D, F).

The species is reported for the state by Tilden, p. 130 (1910). It was found with the following forms: *Calothrix scopulorum* B. & F., *Enteromorpha* sp., *Entophysalis crustacea* (J. Ag.) Dr. and *Lyngbya semiplena* Gom.

3. *Symploca Muscorum* Gomont. Monogr. Oscill. Ann. Sci. Nat. Bot. VII 16: p. 110, pl. 2, f. 9 (1892).

Fasciculate or mucose-phormidioid, extensive, black through dark to blue-green. Fascicles tortuous, repent, more rarely erect. Filaments simple, flexible, closely congested, exceedingly tortuous and entangled toward base, above less tortuous and nearly parallel. Sheaths firm, persistent, or more or less mucous, turning blue with chlor-zinc-iodine, up to 2 microns wide. Trichomes blue-green, never constricted at cross-walls, 5 - 8 microns wide; cells from slightly less to twice trichome diameter, 5 - 11 microns long, filled with protoplasmic granules; cross-walls generally inconspicuous, never granular; apical cell rotund above or obtuse conical, with slightly thickened calyptra.

Alachua county: Gainesville, *Brannon* 312, 7 Sept. 1945 (C, D); *Brannon* 398, 18 Dec. 1946 (C, D). Brevard county: in pineapple field, Malabar, *P. H. Ralfs*, Nov. 1903 (C, D). Duval county: soil surface of lawn, Ortega, Jacksonville, *C. Jackson II*, 5 Aug. 1952 (C, D, F). Gadsden county: Ochlockonee river at U. S. 90, *Nielsen, Madsen & Crowson* 268-272, 274, 31 Aug. 1948 (C, D, F); flood plain and limestone cliffs, Aspalaga on Apalachicola river, *Nielsen, Madsen & Crowson* 735, 759, 760, 12 Feb. 1949 (C, D, F). Jackson county: Fla. Caverns state pk., *Nielsen & Madsen* 321, 322, 326, 31 Aug. 1948 (C, D, F); Fla. highway 71, 5 miles south of Marianna, *Nielsen & Madsen* 342, 343, 344, 346, 31 Aug. 1948 (C, D, F); on barren red clay banks, U. S. 90, 5 miles east of Marianna *Drouet, Nielsen, Madsen & Crowson* 10333, 4 Jan. 1949 (C, D, F); on limestone along Chipola river near exit of cave, Fla. Caverns state pk., *Drouet, Nielsen, Madsen & Crowson* 10354, 10358, 4 Jan. 1949 (C, D, F). Leon county: St. Marks river, Natural Bridge, *Nielsen, Madsen & Crowson* 150, June 1948 (C, D, F); St. Marks river, Little Natural Bridge, *Nielsen, Madsen & Crowson* 157, June 1948 (C, D, F); Lake Ella, Tallahassee, *Nielsen* 262, Aug. 1948 (C, D, F); Meridian rd., 16 miles north of Tallahassee, *Nielsen & Madsen* 356 360, 31 Aug. 1948 (C, D, F); St. Marks river, Natural Bridge, *Nielsen, Madsen & Crowson* 492, 19 Sept. 1948 (C, D, F); St. Marks river, Little Natural Bridge, *Nielsen, Madsen & Crowson* 543, 549, 30 Oct. 1948 (C, D, F); St. Marks river, Natural Bridge, *Nielsen, Madsen & Crowson* 570, 572, 573, 582, 30 Oct. 1948 (C, D, F); in dried pool in open woods, west of F.S.U., Tallahassee, *Drouet & Crowson* 10444, 5 Jan. 1949 (C, D, F); wet ground along Ochlockonee river at U. S. 90 west of Stephensville, *Drouet, Crowson & J. Petersen* 10494, 10497, 10523, 6 Jan. 1949 (C, D, F); wet ground beside Meridian rd. between Lake Iamonia and Ochlockonee river, *Drouet, Kurz & Nielsen* 11252, 24 Jan. 1949 (C, D, F); F.S.U. campus, *A. H. Johnston* 1521, 13 Aug. 1949 (C, D, F); U. S. 90, 7 miles west of Tallahassee, *Nielsen & Crowson* 944, 946, 11 Mar. 1949 (C, D, F); on soil, Jackson Bluff, near Ochlockonee river, *C. Jackson*, 9 Nov. 1950 (C, D, F). Liberty county: Fla. highway 20 at Taluga river, *Nielsen & Madsen* 869, 19 Feb. 1949 (C, D, F); Fla. highway 20, Ochlockonee river swamp, *Nielsen & Kurz* 879, 882, 19 Feb. 1949 (C, D, F). Seminole county: on decaying bark, Altamonte Springs, *P. O. Schallert*, 10 Sept. 1951 (C, D, F). Taylor county: in shallow water of creek, U. S. 27, 1 mile N.W. of Perry, *Drouet & Nielsen*

10757, 11 Jan. 1949 (C, D, F). Wakulla county: Log Spring, north of Newport, *Nielsen, Madsen & Crowson*, 245, Aug. 1948 (C, D, F); Natural Bridge, *Nielsen & Madsen* 554, 579, 30 Oct. 1948 (C, D, F); in roadside ditch, St. Marks river, Newport, *Drouet, Madsen & Crowson* 10808, 10814, 13 Jan. 1949 (C, D, F); Spillway Dam, Phillips Lake, St. Marks Wildlife Refuge, *Madsen, Drouet & Crowson* 813, 821, 14 Jan. 1949 (C, D, F); on wet ground beside small sulphur spring, $\frac{1}{2}$ mile north of Newport, *Drouet, Crowson & R. Thornton* 11344, 25 Jan. 1949 (C, D, F); Spillway Pond, Phillips pool, St. Marks Wildlife Refuge, *Nielsen, Madsen & Crowson* 934, 939, 26 Jan. 1949 (C, D, F); in depression in sand beside road to Port Leon, 1 mile southeast of Newport, *Drouet, Nielsen, Crowson & Atwood* 11434, 26 Jan. 1949 (C, D, F); on submerged sticks in "T" pond of Phillips lake, St. Marks Wildlife Refuge, $\frac{1}{3}$ mile east of Newport, *Crowson & Chamberlain* 32, 15 May 1949 (C, D, F); little sulphur spring, $\frac{1}{2}$ mile north of Newport, *Nielsen*, 15 Oct. 1950 (C, D, F); floating, Spillway Dam, Port Leon, *H. R. Wilson*, 23 July 1952 (C, D, F).

Many of the specimens measured 5 - 6.8 microns in trichome diameter and about 10 microns in cell length. They were commonly associated with: *Anabaena sphaerica* B. & F., *Lyngbya putealis* Gom., *Microcoleus rupicola* (Tild.) Dr., *Mougeotia* sp., *Oscillatoria sancta* Gom., *O. splendida* Gom., *Porphyrosiphon Notarisii* Gom., *Rhizoclonium hieroglyphicum* (Ag.) Kutz., *Scytonema guyanense* B. & F. and *Zygnema* sp.

4. *Symploca muralis* Gomont. Monogr. Oscill. Ann. Sci. Nat. Bot. VII 16: p. 112, pl. 2, f. 10 (1892).

Stratum black to steel blue, continuous, broadly expanded; spiniform fascicles, thick, erect, up to 2 mm. high. Filaments simple, elongate, repent toward base, very tortuous, irregularly entwined, in fascicles less flexuous, ascending almost parallel, firmly congested. Sheaths thin, firm, below somewhat mucous, turning blue with chlor-zinc-iodine. Trichomes blue-green to green, never constricted at cross-walls, apex slightly attenuate, 3.4 - 4 microns wide; cells shorter than trichome diameter to subquadrate, 1.5 - 4 microns long, cross-walls not too conspicuous, never granular; apical cell obtuse conical; calyptra absent.

Baker county: in pine seed bed, U. S. Forestry station, Olustee, *Brannon* 228, May 1944 (C, D). Gadsden county: flood plain and limestone cliffs, Aspalaga on Apalachicola river, *Nielsen, Madsen & Crowson* 733, 12 Feb. 1949 (C, D, F). Jackson county: wayside pk., 5 miles east of Marianna on U. S. 90, *Nielsen* 2101, 8 Feb. 1950

(C, D, F). Jefferson county: Judge Hopkin's camp, Lake Miccosukee, *Nielsen & Crowson* 966, 11 Mar. 1949 (C, D, F). Lake county: on soil, Exp. Station, Leesburg, *Brannon* 228, 297, July 1944 (C, D). Leon county: Judge Andru's magnolia forest, Lake Iamonia, *Nielsen & Madsen* 386, 396, Aug. 1948 (C, D, F); Thomasville hunting club, Lake Iamonia, *Nielsen & Madsen* 408, Aug. 1948 (C, D, F). Marion county: on bank on west shore of Orange Lake, *Drouet, Brannon & McKay* 11012, 19 Jan. 1949 (C, D). Monroe county: public beach, Tavernier, *L. B. Isham* 3, 1 Oct. 1952 (C, D). St. Johns county: greenhouse soil, Hastings, *Brannon* 297, 28 Nov. 1947 (C, D). Wakulla county: "Log" sulphur spring, New port, *Nielsen, Madsen & Crowson* 242, Aug. 1948 (C, D, F).

5. *Symploca Kieneri* Drouet. Amer. Midl. Nat. 29: 53 (1943).

Stratum extensive, pannose, black, olive or blue-green, filaments long slender, below twisted and interwoven, above rarely joined in fascicles, erect or repent and parallel; sheath hyaline, wide, obscurely lamellose, eroded at margins, scarcely turning blue with chlor-zinc-iodine or with age no reaction; trichomes blue-green or green or yellow, 4-10 microns wide, distinctly constricted at cross-walls, gradually attenuate toward apices; cells quadrate to twice trichome width, with large scattered protoplasmic granules, cross-walls never conspicuously granular; apical cell rotund or truncate-conical, membrane obviously thickened above.

Alachua county: on wet sand, Hibiscus pk., Gainesville, *Brannon* 172, 182, 11 May 1943; *Brannon* 249, 16 July 1943 (C, D). Bay county: in depression in sand in pine woods, U. S. 319, 5 miles N.W. of Beacon Hill, *Drouet & Nielsen* 11632, 11633, 31 Jan. 1949 (C, D, F); Laguna beach, west of Panama City Beach on U. S. 98, *Madsen, Pates, Hood & Elias* 1947, 11 Sept. 1949 (C, D, F). Broward county: in depressions in old sand dunes between Dania Beach and Hollywood Beach, *Drouet & Louderback* 10269, 28 Dec. 1948 (C, D). Collier county: on dry sand, near Naples, *P. C. Standley* 73381, 19 Mar. 1940 (C, D); on moist sand, Marco Island, *Standley* 73409, 19 Mar. 1940 (C, D). Duval county: on sand, yard area, Ortega, Jacksonville, *C. Jackson* 10, 5 Aug. 1952 (C, D, F). Escambia county: wet sand in depression in dunes west of Gulf Beach, *Drouet, Nielsen, Madsen & Crowson* 10556, 8 Jan. 1949 (C, D, F). Franklin county: in depression in low sand dunes, shore of Alligator bay east of St. Teresa, *Drouet & Nielsen* 11680, 31 Jan. 1949 (C, D, F). Jackson county: on barren red clay banks, U. S. 90, 5 miles east of Marianna, *Drouet, Nielsen, Madsen & Crowson*

10342, 4 Jan. 1949 (C, D, F). Lake county: Leesburg, *Brannon* 249, 28 July 1944 (C, D). Lee county: on dry sand, Bonita Beach, *Standley* 73219, 14 Mar. 1940 (C, D). Levy county: in upland sand barrens, N.W. part of Way key, Cedar Keys, *Drouet & Nielsen* 11169, 11173, 22 Jan. 1949 (C, D, F); barren ground in open sand woods, Fla. highway 20, 1 mile east of Sumner, *Drouet & Nielsen* 11206, 11207, 23 Jan. 1949 (C, D, F). Manatee county: Terra Ceia, terrestrial, low spot in orange grove, *Wm. R. Maxon* 11275, 2 Jan. 1948 (C, D). St. Johns county: south of St. Augustine, *Standley* 92777, 92778, 18 Mar. 1946 (C, D, F). Wakulla county: barren ground in path, "Log" sulphur spring, 1 mile north of Newport, *Drouet, Crowson & Thornton* 11338, 25 Jan. 1949 (C, D, F); barren ground in prairie of Apalachee bay, 2 miles N.E. of Panacea, *Drouet & Nielsen* 11687, 31 Jan. 1949 (C, D, F); on eroded high bank of East river, west of St. Marks lighthouse, on Gulf of Mexico at mouth of St. Marks river, *Drouet, Madsen & Crowson* 11743, 1 Feb. 1949 (C, D, F).

Drouet states that when found in barren depressions in the sand *S. Kieneri* is very similar to *S. Muscorum* Gom.; however, the former develops thicker sheaths and the trichomes are distinctly constricted. Specimens were found with *Calothrix parietina* B. & F., *Nostoc Muscorum* B. & F., *Porphyrosiphon Notarisii* Gom. and *Schizothrix* sp.

6. *Symploca dubia* Gomont. Monogr. Oscill. Ann. Sci. Nat. Bot. VII 16: p. 115 (1892).

Fibrose-compact, broadly expanded, externally yellow, blue-green, grayish or reddish, internally uncolored due to empty sheaths, above fasciculate, fascicles appressed and anastomosed or erect and very twisted. Filaments wavy, entwined at base, parallel in fascicles. Sheaths wide, firm, irregular at margins, turning blue with chlor-zinc-iodine. Trichomes very pale blue-green, never constricted at cross-walls, 1.5 - 2.5 microns wide; cells up to 4 times as long as diameter of trichome, 3 - 8 microns long, with dispersed protoplasmic granules; cross-walls inconspicuous, occasionally with two granules; apical cell rotund; calyptra absent.

Gadsden county: milestone canyon, Aspalaga on Apalachicola river, *Nielsen, Madsen & Crowson* 770, 12 Feb. 1949 (C, D, F).

Lyngbya C. Agardh

Filaments sheathed, free, simple sometimes caespitose, sometimes entangled into a stratum either floccose or pannose. Sheaths firm,

thin, or turning with age wide and lamellose, hyaline, more rarely yellow to dark. Trichomes in several species constricted at cross-walls, apex straight, equal or slightly attenuate; membrane of apical cell occasionally thickened into a calyptra.

Plants marine, fresh-water or thermal, never terrestrial.

Subgenus I. *Leibleinia*. Plants epiphytic, marine. Filaments attached at middle, erect on all sides. Sheaths thin, hyaline. Trichomes cylindrical to apex.

1. Tufts slippery, purple-violet. Filaments elongate, angularly flexuous. Trichomes 5-8 microns wide 1. *L. gracilis*
2. Small tufts fasciculate, mucose, obscurely blue-green, Filaments elongate, straight, trichomes 6.5-8 microns wide
..... 2. *L. Meneghiniana*
3. Tufts fasciculate, obscurely yellow-green, variously colored upon drying. Filaments straight, semirigid. Trichomes 14-31 microns wide 3. *L. sordida*

Subgenus II. *Eulyngbya*. Plants marine, fresh-water or thermal, saxicolous or free-floating, rarely epiphytic. Filaments caespitose, attached at base or entangled into a floccose stratum. Sheaths often turning wide and lamellose with age.

1. Plants marine or saline.

A. Sheaths never turning blue with chlor-zinc-iodine. Cells very short B.

B. Sheaths always hyaline.

1. Stratum extensive, black to dark to blue-green, filaments more or less wavy. Trichomes 16-60 microns wide, apex never attenuate-capitate; cross-walls not granular 4. *L. majuscula*
2. Stratum generally caespitose, yellow to black-green, filaments straight. Trichomes 9-25 microns wide, apex not attenuate-capitate; cross-walls granular. 5. *L. confervoides*
3. Stratum generally caespitose, dark or obscurely green, filaments flexuous. Trichomes 5-12 microns wide, apex often attenuate-capitate; cross-walls granular 6. *L. semiplena*

BB. Sheaths finally yellow-dark.

1. Stratum ferruginous or blue-green. Trichomes slightly attenuate-capitate at apex, 8 - 24 microns wide; cross walls granular 7. *L. aestuarii*

AA. Sheaths turning blue with chlor-zinc-iodine; cells subquadrate or up to $\frac{1}{3}$ of diameter in length.

1. Stratum subgelatinous, yellow-dark. Trichomes 2.5 - 6 microns wide 8. *L. lutea*

2. Plants fresh-water or thermal, occasionally saline.

A. Trichomes 4 microns or more wide B.

B. Plants caespitose.

1. Tufts obscurely blue-green, filaments erect. Trichomes torulose, 7.5 - 13 microns wide; cells quadrate to $\frac{1}{3}$ diameter in length 9. *L. putealis*
2. Tufts brilliant blue-green, filaments straight, parallel, flexuous. Trichomes generally not torulose (rarely slightly constricted toward apex), 4 - 7 microns wide; cells quadrate or shorter than trichome diameter, 2 - 7 microns long 10. *L. Taylorii*
3. Tufts blue-green, filaments long, straight, fragile. Trichomes never torulose, 5 - 10 microns wide; cells 3 - 6 times shorter than diameter 11. *L. Patrickiana*

BB. Plants not caespitose.

1. Filaments forming a compact ferruginous stratum. Trichomes approximately 3 microns wide 12. *L. versicolor*
2. Filaments solitary, regularly spiralled. Cells 1 - 7 microns wide; planktonic, occasionally marine 13. *L. contorta*

AA. Trichomes less than 4 microns wide.

1. More or less regularly spiralled, occasionally straight. Trichomes blue-green, 2 microns wide 14. *L. Lagerheimii*
2. Filaments entwined into a yellow-brown stratum, flexuous, fragile. Trichomes blue-green, exceedingly torulose, 0.9 microns wide 15. *L. ochracea*

3. Filaments solitary, almost straight or subflexuous, epiphytic on other algae. Sheath very thin, hyaline. Trichomes blue-green, somewhat constricted at cross-walls, 1.8 - 2.8 microns wide 16. *L. infixa*
4. Filaments entwined into brilliant blue-green stratum, twisted at base, straight at end. Trichomes not torulose, 2 - 3 microns wide 17. *L. Diguetii*
5. Filaments straight or slightly curved, individual. Trichomes blue-green, 1 - 2 microns wide, not torulose. Planktonic, saline tolerant 18. *L. limnetica*

Subgenus I. *Leibleinia* Gomont.

Filaments caespitose, attached to submerged plants, attached to middle and entwined, then ascending on all sides. Sheaths thin, hyaline, never conspicuously lamellose. Trichomes not attenuate at apex. Plant marine.

1. *Lyngbya gracilis* Gomont. Monogr. Oscill. Ann. Sci. Nat. Bot. VII 16: p. 124, pl. 2, f. 20 (1892).

Tufts extensive, dense, floccose, slippery, purple-violet, often discolored and dark yellow upon drying, up to ½ cm. tall. Filaments elongate, pliable, angularly flexuous. Sheaths firm, smooth, not turning blue with chlor-zinc-iodine. Trichomes rose-colored, torulose (in dried specimens), 5 - 8 microns wide, apex never attenuate; cells quadrate to one-half of trichome diameter, 2.8 - 4.6 microns long, filled with small protoplasmic granules; apical cell rotund, membrane slightly thickened above.

Bay county: St. Andrews Bay, east of St. Andrew, *Madsen, Pates, Hood & Elias* 1570, 17 Apr. 1949 (C, D, F).

2. *Lyngbya Meneghiniana* Gomont. Monogr. Oscill. Ann. Sci. Nat. Bot. VII 16: p. 125 (1892).

Small tufts fasciculate, mucose, obscurely blue-green, to 1 cm. tall. Filaments elongate, straight, exceedingly pliable. Sheaths thin, smooth, not turning blue with chlor-zinc-iodine. Trichomes pale blue-green, torulose (in dried specimen), apices never attenuate, 6.5 - 8 microns wide; cells from 2 - 4 times shorter than diameter of trichome, 2 - 4 microns long, filled with small protoplasmic granules; apical cell rotund, membrane a little thickened above.

Monroe county: Key West, *Marshall A. Howe*, 7 Nov. 1902 (C, D).

3. *Lyngbya sordida* Gomont. Monogr. Oscill. Ann. Sci. Nat. Bot. VII 16: p. 126, pl. 2, f. 21 (1892).

Tufts fasciculate, obscurely to darkly yellow-green, upon drying generally black-violet, to 3 cm. tall. Filaments straight, semirigid. Sheaths smooth, turning blue with chlor-zinc-iodine. Trichomes olivaceous, purple on drying, blue or yellow-green, markedly torulose, apices never attenuate, 14 - 31 microns wide; cells from 2 - 6 times shorter than diameter of trichome, 4 - 10 microns long, frequently sparsely filled with large protoplasmic granules; apical cell rotund; calyptra absent.

Forma *Bostrychicola*.—Trichomes only 14 - 20 microns wide; cells up to 10 microns long.

Wakulla county: as epiphytes on *Padina vickersiae* Hoyt. From rocky bottom about 4 miles ESE of St. Marks lighthouse, in 8 ft. water, *H. J. Humm*, 17 Aug. 1952 (C, D, F).

The specimen cited was found with *Entophysalis conferta* (Kütz.) Dr. & Daily.

Subgenus II. *Eulyngbya*

Filaments entwined into a floccose or pannose stratum or caespitose, fixed at base, even free-floating. Sheaths often becoming wide and lamellose with age, occasionally yellow-dark. Trichomes at times attenuate at apex.

Plants marine, fresh-water or thermal, saxicolous, more rarely epiphytic.

4. *Lyngbya majuscula* Gomont. Monogr. Oscill. Ann. Sci. Nat. Bot. VII 16: p. 131, pl. 3, f. 3 - 4 (1892).

Plants extensive, up to 3 decimeters long, black-blue, obscurely blue-green, dark, even yellowish-green. Filaments exceedingly elongate, more often wavy, even circinate, more rarely moderately flexuous. Sheaths hyaline, becoming very wide with age, externally rough, up to 11 microns wide, not turning blue with chlor-zinc-iodine. Trichomes blue-green, dark green or bluish-gray to steel blue, not constricted at cross-walls, apex never attenuate, 16 - 60 microns, generally 20 - 40 microns wide; cells very short, 1/6 to 1/15 of trichome diameter, 2 - 4 microns long, densely filled with small protoplasmic granules; cross-walls never granular; apical cell rotund; calyptra absent.

Florida, *W. G. Farlow* 33, Nov. 1891 (C, D). Monroe county: Key West, *F. W. Hooper*, (C, D); Key West, *Dr. E. Palmer*, 1874 (C, D); Key West, *Marshall A. Howe* 1627, 7 Nov. 1902 (C, D); Garden Key, *Wm. R. Taylor* 1127, June 1926 (C, D); Bird Key, reef, very shallow water on stone, *Taylor*, 2 June 1926 (C, D).

Pinellas county: St. Petersburg Beach, *Paul O. Schallert 2080A, 2081*, 20 Feb. 1949 (C, D); Pass-a-Grill Beach, St. Petersburg, *Helen Harris*, 12 May 1950 (C, D, F).

The species is reported for the state by Tilden, p. 124 (1910).

5. *Lyngbya confervoides* Gomont. Monogr. Oscill. Ann. Sci. Nat. Bot. VII 16; p. 136, pl. 3, f. 5 - 6 (1892).

Tufts extensive, fasciculate, mucose, approximately 5 cm. tall, dark-yellowish to black-green, occasionally becoming violet upon drying, or entangled as a pannose stratum. Filaments decumbent and entangled at base, ascending elongate, straight, almost rigid. Sheaths hyaline, becoming lamellose with age, externally rough, up to 5 microns wide, never turning blue with chlor-zinc-iodine. Trichomes olive to blue-green not constricted at cross-walls, apex never attenuate, 9 - 25 microns, generally 10 - 16 microns wide; cell $1/3$ - $1/8$ trichome diameter in length, 2 - 4 microns long; cross-walls generally granular; apical cell rotund; calyptra absent.

Bay county: intertidal on stone jetty in St. Andrews bay at Frankfort st. & Beach dr., St. Andrews, Panama City, *Drouet & Nielsen 10916*, 15 Jan. 1949 (C, D, F). Broward county: on pilings in Intracoastal waterway between Dania beach & Hollywood beach, *Drouet & Louderback 10267, 10268*, 28 Dec. 1948 (C, D). Dade county: Cutler, Biscayne Bay, *Humm*, 13 Jan. 1946 (C, D); atop concrete breakwater at foot of 50th st., Miami Beach, *Humm*, 14 Jan. 1946 (C, D). Duval county: pilings of pier, 2 miles south of St. Johns river mouth, Jacksonville Beach, *Humm*, 19 Mar. 1948 (C, D, F). Hillsborough county: in shallow water, south side Davis Causeway near center, Tampa Bay, *Humm*, 11 July 1951 (C, D). Levy county: intertidal on woodwork at Municipal wharf, Way Key, Cedar Keys, *Drouet & Nielsen 11108, 11121, 11142*, 22 Jan. 1949 (C, D, F). Monroe county: Key West, *W. G. Farlow*, Nov. 1891 (C, D). Okaloosa county: intertidal on pilings in Santa Rosa sound, at west end of bridge on U. S. 98, Fort Walton, *Drouet, Nielsen, Madsen, Crowson & Pates 10643*, 9 Jan. 1949 (C, D, F). Palm Beach county: on submerged log, Lake Worth inlet, *R. Thaxter*, 1898-1899 (C, D); on sand between tide-marks in Lake Worth at Flaglar Memorial bridge, West Palm Beach, *Drouet & Louderback 10194, 10195*, 23 Dec. 1948 (C, D, F); near high tide-mark in jetties, ocean beach at east end of Sunset ave., Palm Beach, *Drouet & Louderback 10201*, 24 Dec. 1948 (C, D); in the tide pools on rocks at point north of ocean beach, Singers island, east of Riviera, *Drouet &*

Louderback 10227, 10228, 10232, 25 Dec. 1949 (C, D). St. Johns county: on sand-covered rocks of jetty, littoral, Anastasia island, St. Augustine, M. A. Howe 1186, 4 Oct. 1902 (D); St. Augustine, north of bridge on western side of Anastasia island, Madsen, Pates & Parker 2024, 2 Jan. 1950 (C, D, F). Taylor county: on pilings, between tide limits on shore of Steinhatchee river in southern part of Steinhatchee, Drouet & Nielsen 11229, 23 Jan. 1949 (C, D, F); Adam's beach, Madsen & Pates 1089, 4 May 1949 (C, D, F). Wakulla county: intertidal, St. Marks river, Port Leon, Drouet & Atwood 11454, 26 Jan. 1949 (C, D, F); intertidal on stones of jetty west of St. Marks lighthouse, on Gulf of Mexico at mouth of St. Marks river, Drouet, Madsen & Crowson 11764, 1 Feb. 1949 (C, D, F); lighthouse jetty, St. Marks Wildlife Refuge, Nielsen & Crowson, 1, 2, 3, 4, May 1949 (C, D, F); St. Marks lighthouse, Humm, 25 Mar. 1950 (C, D); Shell Point, Gulf of Mexico, on oyster shells in channel, Nielsen 3, 7 Nov. 1952 (C, D, F).

The species is reported for the state by Tilden, Minn. Alg. I, p. 120 (1910) and by Farlow (1875) as *L. luteofusca* Ag. Collections contained the following species: *Entophyialis conferta* (Kg.) Dr. & Daily, *Lyngbya infixa* Freymy, *Monostroma* sp. and *Phormidium fragile* Gom.

6. *Lyngbya semiplena* Gomont. Monogr. Oscill. Ann. Sci. Nat. Bot. VII 16: p. 138, pl. 3, f. 7 - 11 (1892).

Tufts extensive, mucose, rarely more than 3 cm. high, generally darkly yellow-green, or obscurely green, occasionally upon drying black-violet, or entwining into a pannose stratum. Filaments decumbent and entwined at base, ascending slender and flexuous. Sheaths hyaline, submucous, with age becoming lamellose, up to 3 microns wide, not turning blue with chlor-zinc-iodine. Trichomes yellow-green or blue-green, apex slightly attenuate, capitate, never constricted at cross-walls, 5 - 12 microns, generally 7 - 10 microns wide; cells 1/3 - 1/6 of trichome diameter in length, 2 - 3 microns long; cross-walls frequently granular; apical cell with a calyptra depressed-conical or rotund.

Bay county: intertidal at bridge across west arm of St. Andrews bay, West Bay, *Drouet & Nielsen 10864, 15 Jan. 1949 (C, D, F); intertidal on shore of St. Andrews bay, Cove Hotel, Panama City, Drouet & Nielsen 11610, 11611, 11614, 11617, 11623, 30 Jan. 1949 (C, D, F). Broward county: with *Enteromorpha* sp. on tidal mud-flats behind Dania Beach, *Drouet & Louderback 10264, 28 Dec. 1948 (C, D); on mangrove roots in intracoastal waterway, Drouet & Louderback**

10266, 28 Dec. 1948 (C, D); between tidemarks in mangrove swamp south of South Lake, Hollywood, *Drouet* 10301, 10305, 29 Dec. 1948 (C, D). Collier county: in brackish pool, Marco island, *Paul C. Standley* 73406, 73521, 73527, 19 Mar. 1940 (C, D); 92812, 92813, 14 Mar. 1946 (C, D). Dade county: on shells, Biscayne Bay, Cutler, *Humm*, 13 Jan. 1946 (C, D); 30 Aug. 1950 (C, D); 1 Sept. 1950 (C, D). Escambia county: intertidal on shore of Pensacola Bay north of bay bridge on U. S. 98, Pensacola, *Drouet, Nielsen, Madsen, Crowson & Pates* 10622, 8 Jan. 1949 (C, D, F). Franklin county: between tide limits at docks in New river, Carrabelle, *Drouet & Nielsen* 10971, 16 Jan. 1949 (C, D, F). Gulf county: on rocks of retaining wall, 2 miles N.W. of Port St. Joe on U. S. 98, *Madsen, Pates, Hood & Elias* 1510, 31 July 1949 (C, D, F). Hernando county: Battery Point, *Brannon* 561, Oct. 1948 (C, D). Lee county: Bonita beach, *Standley* 92787, 10 Mar. 1946 (C, D). Monroe county: on rock, North Key Largo, *Isham* 21, 1952 (C, D). Okaloosa county: intertidal on pilings in Choctawhatchee bay, east end of Santa Rosa island, *Drouet, Nielsen, Madsen, Crowson & Pates* 10633, 10635, 9 Jan. 1949 (C, D, F); intertidal on rocks in Santa Rosa sound, west end of bridge on U. S. 98, Ft. Walton, *Drouet, Nielsen, Madsen, Crowson & Pates* 10641, 10643, 9 Jan. 1949 (C, D, F). Palm Beach county: in clam shells in shallow water of Lake Worth at Flagler Mem. bridge, West Palm Beach, *Drouet & Louderback* 10197, 23 Dec. 1948 (C, D); between tide-marks on jetties, Ocean Beach at east end of Sunset Ave., Palm Beach, *Drouet & Louderback* 10202, 10233, 24 Dec. 1948 (C, D); on rocks in tide-pools at point north of Ocean Beach, Singers island, east of Riviera, *Drouet & Louderback* 10230, 25 Dec. 1948 (C, D). Taylor county: between tide limits on shore of Steinhatchee river in southern part of Steinhatchee, *Drouet & Nielsen* 11230, 11236, 11237, 11238, 23 Jan. 1949 (C, D, F); Adams Beach, *Madsen & Pates* 1088, 4 May 1949 (C, D, F). Volusia county: Daytona causeway (west end), *Madsen & Pates* 1605, 19 Mar. 1949 (C, D, F). Wakulla county: lighthouse pool, St. Marks Wildlife Refuge, *Crowson* 69, May 1948 (C, D, F); intertidal on east shore of East river, west of St. Marks lighthouse, Gulf of Mexico at mouth of St. Marks river, *Drouet, Madsen & Crowson* 11729, 1 Feb. 1949 (C, D, F); in salt marsh along East river about 1 mile N.E. of St. Marks lighthouse, Gulf of Mexico at mouth of St. Marks river, *Drouet, Madsen & Crowson* 11764, 11765, 1 Feb. 1949 (C, D, F).

The Florida collection of *Smith*, Mar. 1878 (P, D) cited as *Calothrix Donnellii* in Wolle, Bull. Torr. Club 6: 283 (1879) and in Tilden, Minn. Alg. 1: 271 (1910) has been referred to this species (Drouet 1939). Collections contained: *Amphithrix violacea* B. & F., *Hyella caespitosa* B. & F., *Lyngbya aestuarii* Gom., *L. confervoides* Gom. and *Microcoleus chthonoplastes* Gom.

7. *Lyngbya aestuarii* Gomont. Monogr. Oscill. Ann. Sci. Nat. Bot. VII 16: p. 127, pl. 3, f. 1 - 2 (1892).

Stratum exceedingly expanded, more or less very dark to obscurely blue-green, limicolous, pannose, compact, or floating and floccose. Filaments elongate, pliant, never pseudo-branched, generally tortuous and closely congested, or moderately flexuous to almost straight and loosely entangled, occasionally forming erect fascicles in areas of running water. Sheaths at first hyaline, thin, smooth, with age becoming wide, externally rough, more or less intensely yellow-dark, lamellose, with discolored layers, never turning blue with chlor-zinc-iodine. Trichomes blue-green to olive, never constricted at cross-walls, apex slightly attenuate-capitate, truncate, more rarely subacutely conical, 8-24 microns generally 10-16 microns wide; cells 1/3-1/6 of trichome diameter in length, 2.7-5.6 microns long, filled with small protoplasmic granules; cross-walls never granular; membrane of apical cell slightly thickened above.

Forma *limicola*. Stratum exundate, pannose, compact, almost thin. Filaments closely congested and generally tortuous.

Forma *natans*. Stratum inundate, attached in mud, later floating. Filaments elongate, moderately flexuous or nearly straight, loosely entangled.

Forma *symplocoidea*. Stratum exundate. Filaments prostrate at base, entangled, above joining into dense erect fascicles.

Alachua county: Sink I, Hibiscus pk., Gainesville, *Brannon* 9, III, Sept. 1941 (C, D); Gainesville, *Brannon* 203, 5 Sept. 1943 (C, D). Broward county: intertidal mud-flats at east end of Hollywood blvd., *Drouet & Louderback* 10258, 27 Dec. 1948 (C, D); drying ground beside intracoastal waterway between Dania beach and Hollywood beach, *Drouet & Louderback* 10270, 28 Dec. 1948 (C, D); on tidal mud-flat, Dania beach, *Drouet & Louderback* 10278, 28 Dec. 1948 (C, D); on drying mud-flats in mangrove swamp, south of South lake, Hollywood, *Drouet* 10294, 10302, 10305, 10306, 10313. Dade county: soil in salt flat near Flamingo, Everglades Nat'l, pk., *A. J. Sharp* 732, 21 Dec. 1948 (C, D). Hamilton county: Westlake, *J. H. Davis, Jr.*, summer 1937, (C, D). Hernando county:

in sand on log on shore of Battery Point, *Brannon* 578, Oct. 1948 (C, D). Lee county: on moist sand, region of Hendry Creek, about 10 miles south of Fort Myers, *Standley* 73459, 73252, 73204, 11-25 Mar. 1940 (C, D). Leon county: mouth of drainage ditch on river bank, Jackson Bluff on Ochlockonee river, *C. Jackson*, 9 Nov. 1950 (C, D, F). Monroe county: Key West, *W. G. Farlow*, Nov. 1891 (C, D); in barren ground along shore near Big Pine Inn, Big Pine Key, *M. Alice Cornman*, 2 May 1943 (C, D); saline flats, south of Big Pine Inn, Big Pine Key, *Killip & J. Francis Macbride*, Apr. 1951 (C, D); brackish water, interior of Stake Key, Florida Bay, *L. B. Isham* 18, 1952 (C, D); Cudjoe Key, *Isham* 8, 1952 (C, D); Florida Keys, mud-flats north end of Florida Bay, Snake Bight, *R. N. Ginsberg*, 1952 (C, D); dark green, S.W. point, on white marl, Big Pine Key, *Killip* 41793, 41794, 41796, 19 Jan. 1952 (C, D); saline flats, east side of bay, near Dinosaur stump, Big Pine Key, *Killip* 41809, 22 Jan. 1952 (C, D); grayish white, saline flats near Knight home, Big Pine Key, *Killip* 41818, 24 Jan. 1952 (C, D); black soil which extends downward at least 2 ft., saline flats west of lower part of road to Shell Beach, Big Pine Key, *Killip* 41855, 31 Jan. 1952 (C, D); dried-up sink-hole in clearing, N.E. of Watson Hammock, Big Pine Key, *Killip* 42017, 19 Mar. 1952 (C, D). Taylor county: intertidal at confluence of Daughter creek and Steinhatchee river, Steinhatchee, *Drouet & Nielsen* 11221A, 23 Jan. 1949 (C, D, F). Wakulla county: Mounds pool, roadside ditch, St. Marks Wildlife Refuge, *Nielsen, Madsen & Crowson* 124, June 1948 (C, D, F); 487, 9 Oct. 1948 (C, D, F); *Nielsen & Madsen* 670, 671, 673, 676, 7 Nov. 1948 (C, D, F); in stream from small sulphur spring one-half mile south of Newport, *Drouet, Crowson & Thornton* 11351, 25 Jan. 1949 (C, D, F); on shore of lighthouse pool, west of St. Marks lighthouse on Gulf of Mexico, at mouth of St. Marks river, *Drouet, Madsen & Crowson* 11755, 1 Feb. 1949 (C, D, F); moist earth, Port Leon, *Harmon* 18, 11 Nov. 1950 (C, D, F); soil, edge of Phillips Pool, Port Leon, *C. Jackson* 5, 6, 11 Nov. 1950 (C, D, F); on rock, brackish stream along main road, St. Marks Wildlife Refuge, *Nielsen* 1, 3, 4, 5, 7, 4 Oct. 1951 (C, D, F); salt flats, north of lighthouse, St. Marks Wildlife Refuge, *Nielsen* 7, 8, 4 Oct. 1951 (C, D, F); soil, Shell Point, Gulf of Mexico, *Nielsen* 13, 7 Nov. 1952 (C, D, F); *Nielsen, Hanks & Kurz* 30, 16 Jan. 1953 (C, D, F).

Collections of the species commonly contained the following algae: *Coccochloris stagnina* f. *rupestris* (Lyng.) Dr. & Daily,

Lyngbya semiplena Gom., *L. versicolor* Gom., *Microcoleus chthonoplastes* Gom., *M. tenerrimus* Gom., *Oscillatoria Agardhii* Gom., *O. laetevirens* Gom. and *Schizothrix longiarticulata* Gardn. The species is reported for the state by Wolle, F. W. Alg. 296 (1887) and by Farlow (1875) as *L. luteofusca* Ag.

8. *Lyngbya lutea* Gomont. Monogr. Oscill. Ann. Sci. Nat. Bot. VII 16: p. 141, pl. 3, f. 12 - 13 (1892).

Stratum subgelatinous, coriaceous, yellow-dark to olive, often black-violet upon drying. Filaments twisted, flexuous, closely entangled. Sheaths hyaline, smooth, turning blue with chlor-zinc-iodine, at first thin, becoming lamellose, and up to 3 microns wide with age. Trichomes olive, not constricted at cross-walls, apex never attenuate, 2.5-6 microns wide; cells quadrate or up to 1/3 shorter than diameter, 1.5-5.5 microns long, filled with protoplasmic granules, generally obscuring cross-walls; apical cell producing rotund calyptra.

Bay county: intertidal on woodwork in west arm of St. Andrews bay, West Bay, *Drouet & Nielsen 10878*, 15 Jan. 1949 (C, D, F). Broward county: in intracoastal waterway, Dania beach, *Drouet & Louderback 10275A*, 28 Dec. 1948 (C, D). Collier county: brackish pool, Marco Island, *Standley 73402, 73525*, 19 Mar. 1940 (C, D). Franklin county: intertidal on wood, north shore of St. Vincent Sound about 10 miles west of Apalachicola, *Drouet & Nielsen 10981*, 16 Jan. 1949 (C, D, F). Gulf county: intertidal in stream entering St. Joseph Bay by U. S. 319, north of rd. to Constitution pk., Port St. Joe, *Drouet & Nielsen 11643*, 31 Jan. 1949 (C, D, F). Monroe county: *R. Thaxter*, 1889 (C, D). Okaloosa county: intertidal pilings in Choctawhatchee Bay, east end of Santa Rosa island, *Drouet, Nielsen, Madsen, Crowson & Pates 10633*, 9 Jan. 1949 (C, D, F). Wakulla county: intertidal, St. Marks river, Port Leon, *Drouet & Atwood 11453, 11461B*, 26 Jan. 1949 (C, D, F); lighthouse jetty, St. Marks Wildlife Refuge, *Nielsen & Crowson*, May 1949 (C, D, F).

Specimens were found with *Entophyalis deusta* (Menegh.) Dr. & Daily.

9. *Lyngbya putealis* Gomont. Monogr. Oscill. Ann. Sci. Nat. Bot. VII 16: p. 143, pl. 3, f. 14 (1892).

Tufts extensive, black-green. Filaments exceedingly elongate, firm, straight, rigid upon drying. Sheaths hyaline, thin, papery, not turning blue with chlor-zinc-iodine. Trichomes obscurely green, not constricted at cross-walls, apex attenuate, capitate, 8-11 microns wide; cells 1/2 - 1/4 of trichome diameter in length, 2-4 microns long, filled with large proto-

plasmic granules, cross-walls frequently obscured; cross-walls never granular; apical cell with depressed-conical calyptra.

Alachua county: Sink I, Hibiscus pk., Gainesville, *Brannon* 26, Aug. 1941 (C, D); Gainesville, *Brannon* 38, 27 Mar. 1942 (C, D); Lake Wauberg, Gainesville, *J. S. Rogers* 106, May 1943 (C, D); Gainesville, duck pond on submerged stick, *Brannon* 322, 22 May 1948 (C, D). Brevard county: pineapple field, Malabar, *P. H. Ralfs*, Nov. 1903 (C, D). Citrus county: Hernando, *Brannon* 210, 15 Apr. 1944 (C, D). Franklin county: Apalachicola bay, west end of John Gorrie bridge, Apalachicola, *Madsen, Pates, Hood & Elias* 1509A, 31 July 1949 (C, D, F). Gadsden county: Apalachicola river at Chattahoochee, *Nielsen, Madsen & Crowson* 277, 278, 282, 283, 285, 31 Aug. 1948 (C, D, F); Little River, U. S. 90, 8 miles east of Quincy, *Nielsen* 1428, 9 July 1949 (C, D, F). Hillsborough county: sulphur spring at Beach Pk., west of Tampa, *J. C. Dickinson, Jr.*, 7 June 1939 (C, D). Leon county: submerged on limestone, Ochlockonee river at Jackson Bluff, *C. Jackson*, 9 Nov. 1950 (C, D, F). Marion county: Rock Springs, *Mrs. F. A. Curtiss*, 25 Mar. 1893 (C, D). Palm Beach county: Jupiter inlet, *Mrs. G. A. Hall*, Oct. 1897 (C, D). Wakulla county: limestone, Spillway Dam, Port Leon, *H. R. Wilson*, 23 July 1952.

Specimens were found with *Plectonema Nostocorum* Gom. The species is reported for the state as *Lyngbya subtorulosa* (Breb.) Wolle in Wolle, *F. W. Alg.* 300 (1887).

10. *Lyngbya Taylorii* Drouet & Strickland. *Amer. Journ. Bot.* 27: 628 (1940).

Tufts extensive, penicillate and radiating, up to 1/2 cm. long, brilliant blue-green; filaments elongate, straight, parallel, flexuous; sheaths at first thin later wide and obscurely lamellose, uncolored, turning very blue with chlor-zinc-iodine; trichomes blue-green, 4-7 microns wide, not attenuate toward apex, generally not constricted at cross-walls (rarely slightly constricted toward apex); cells quadrate or shorter than trichome diameter, 2-7 microns long; protoplasm granular, cross-walls never granular; apical cell rotund, with thickened membrane.

Alachua county: Gainesville, *Brannon* 143, 144A, 7 Feb. 1943 (C, D); Bivens Arm, Gainesville, *Brannon* 9, 202, May 1943 (C, D); Lake Wauberg, Gainesville, *Brannon* 106, 111, May 1943 (C, D). Marion county: Dunnellon, *Brannon* 379, 20 Oct. 1946 (C, D). Pinellas county: Old Tidwell Place, *Nielsen, Madsen & Crowson* 471, 19 Sept. 1948 (C, D, F).

Drouet states the species occurs on larger water plants, rocks and wood in fresh water and sometimes is seen detached in floating tufts. The habit and filaments bear a superficial resemblance to that of *Tolypothrix tenuis* B. & F. The Florida specimens included plants of *Lyngbya aestuarii* Gom. and *Oscillatoria princeps* Gom.

11. *Lyngbya Patrickiana* Drouet. Field Mus. Bot. Ser. 20 (6): 135 (1942).

Tufts blue-green, up to 5 cm. tall, slender; filaments long, straight, fragile; sheath at first membranaceous, later thicker and lamellose, turning brilliant blue with chlor-zinc-iodine; trichomes blue-green, cylindrical, 5-10 microns wide, never constricted at cross-walls, not attenuate toward apex; cells 3-6 times shorter than diameter, cross-walls conspicuous, not or finely granular; apical cell rotund, membrane above not or scarcely thickened.

Alachua county: Sink I, Hibiscus pk., *Brannon 20, 84*, Aug. 1942 (C, D); Gainesville, *Brannon 112, 113*, 6 Oct. 1942 (C, D); *121*, 6 Nov. 1942 (C, D); *287*, 18 Oct. 1944 (C, D). Broward county: about 10 miles from Hollywood, on Fla. 149 about one-half block from railroad near turn, *Ruth Patrick* (C, D). Lee county: fresh-water pool, region of Hendry creek, about 10 miles south of Fort Myers, *Standley 73246*, 11-25 Mar. 1940 (C, D). Leon county: F.S.U. botany dept. greenhouse, *Nielsen 101*, June 1948 (C, D). Wakulla county: Mounds pool, St. Marks Wildlife Refuge, *Nielsen 36, 37*, Apr. 1948 (C, D, F); picnic spring, Newport, *Nielsen, Madsen & Crowson 165*, 14 July 1948 (C, D, F); *488, 490*, 9 Oct. 1948 (C, D, F); *668*, 7 Nov. 1948 (C, D, F); *Nielsen 1, 2*, 15 Oct. 1950 (C, D, F).

Collections included the following species: *Aulosira implexa* B. & F., *Lyngbya versicolor* Gom. and *Oscillatoria tenuis* var. *natans* Gom.

12. *Lyngbya versicolor* Gomont. Monogr. Oscill. Ann. Sci. Nat. Bot. VII 16: p. 147, pl. 4, f. 4-5 (1892).

Stratum at first attached, later free-floating, slippery, somewhat delicate, externally ferruginous, internally darkly olive-green. Filaments elongate, tortuous, firmly entangled. Sheaths hyaline, occasionally yellowish, slightly mucose and agglutinated, up to 2 microns wide, turning blue with chlor-zinc-iodine. Trichomes blue-green, not constricted at cross-walls, apex neither attenuate nor capitate, 2.8-3.2 microns wide; cells generally subquadrate, more rarely shorter than or double trichome diameter in length, 2-6.4 microns long; cross-walls translucent, very occasionally granular; apical cell rotund; calyptra absent.

Alachua county: Gainesville, *Brannon 112, 113*, 6 Oct. 1942 (C, D); 287, 18 Oct. 1944 (C, D); fish aquarium, U. of Fla., *H. E. Brantley 72*, July 1944 (C, D). Collier county: Marco island, *Standley 92837*, 14 Mar. 1946 (C, D). Lake county: Griffin's Lake, Leesburg, *Brannon 253, 254, 279*, July 1944 (C, D); in shallow water of Lake Harris in western part of municipal park, Leesburg, *Drouet & Brannon 11061*, 19 Jan. 1949 (C, D). Lee county: Hendry Creek, *Standley 92766*, 10 Mar. 1946 (C, D). Manatee county: on pottery bird bath, 315 16th st., Bradenton, *C. B. Stifler*, fall of 1945 (C, D); water reservoir, Bradenton, *Brannon 360*, 5 June 1949 (C, D). Monroe county: brackish water, interior of Stake Key, Florida Bay, *L. B. Isham 18*, 1952 (C, D); floating on dense mats of *Ruppia* sp., SE Hammock, Big Pine Key, *Killip 41705*, 10 Jan. 1952 (C, D). Wakulla county: Spillway Dam, Phillips lake, St. Marks Wildlife Refuge, *Drouet & Crowson 816*, 14 Jan. 1949 (C, D, F); on outlet of large sulphur spring bathing pool, one mile north of Newport, *Drouet, Crowson & Thornton 11384*, 25 Jan. 1949 (C, D, F).

The Florida collection cited in Wolle, F. W. Alg. 298 (1887) as *Lyngbya obscura* Wolle has been referred to *L. versicolor* Gom. (Drouet 1939). Collections contained *Lyngbya aestuarii* Gom. and *L. Patrickiana* Dr.

13. *Lyngbya contorta* Lemm. Plöner Forschber. 6, p. 202, pl. 5, f. 10 - 13 (1898).

Filaments solitary, floating, regularly spiralled, with tight, nearly circular coils, 1 - 1.5 microns wide. Sheaths narrow, colorless. Cells 1 - 2 microns wide, 3 - 5 microns long, not constricted at cross-walls, with or without granules. Apical cell rounded, not attenuate. Planktonic in lakes, often also in brackish waters.

Lake county: Griffin's Lake, Leesburg, *Brannon 253*, July 1944 (C, D); in shallow water, shore of Lake Harris, western part of municipal park, Leesburg, *Drouet & Brannon 11064*, 19 Jan. 1949 (C, D). Polk county: Lake Eagle, near Winter Haven, *Nielsen 154*, June 1948 (C, D, F). Putnam county: plankton of St. Johns river, opposite Welaka, *E. Lowe Pierce*, 9 July 1940 (C, D).

Gloeocapsa limnetica (Lemm.) Hollerb., *Hapalosiphon pumilus* B. & F. and *Raphidiopsis curvata* Fritsch were found in the collections.

14. *Lyngbya Lagerheimii* Gomont. Monogr. Oscill. Ann. Sci. Nat. Bot. VII 16: p. 147, pl. 4, f. 6 - 7, 1892.

Filaments more or less regularly spiralled, occasionally straight. Sheaths thin, hyaline. Trichomes about 2 microns wide; cells shorter or longer than diameter of trichome, 1.2 - 3 microns long; cross-walls characterized by two protoplasmic granules.

Hamilton county: Westlake, *J. H. Davis, Jr.*, summer 1937 (C, D).
 Monroe county: in shallow fresh-water pond on coral rock, Lower Matecumbe Key, *A. M. Scott 87*, 19 Oct. 1947 (C, D).

Phormidium inundatum Gom. occurred with the above collections.

15. *Lyngbya ochracea* Gomont. Monogr. Oscill. Ann. Sci. Nat. Bot. VII 16: p. 149 (1892).

Filaments very slender, entangled into a yellow-ochraceous stratum, more or less curved, fragile. Sheaths at first thin, hyaline, finally wide and ochraceous, not turning blue with chlor-zinc-iodine. Trichomes blue-green, frequently breaking apart, exceedingly torulose, 0.9 microns wide; cells shorter than trichome diameter, 0.6 - 0.8 microns long; cross-walls never granular; apical cell rotund; calyptra absent.

Alachua county: on sand, Hibiscus pk., Gainesville, *Brannon 192*, Aug. 1943 (C, D). Liberty county: Deep Cut creek, Aspalaga on Apalachicola river, *Madsen, Wagner & Pates 2072*, 15 Apr. 1950 (C, D, F).

16. *Lyngbya infixa* Fremy. Compt. Rend. Acad. Sci. Paris 195: p. 1414 (1932); Mem. Soc. Nat. Sci. Nat. & Math. Cherbourg 41: p. 110, pl. 30, f. 1 (1934).

Filaments solitary or some loosely associated, semi-erect or subflexuous, considerably elongate, attached at base. Sheaths very thin, hardly visible, hyaline, never turning blue with chlor-zinc-iodine. Trichomes in dried specimens pale blue-green; not constricted at cross-walls, generally 1.8 - 2 microns, more rarely up to 2.8 microns wide; cells usually shorter than wide, more rarely subquadrate, 1 - 2 microns long; cross-walls conspicuous, pellucid, non-granular; protoplasm conspicuously granular; apical cell neither attenuate nor capitate, with rotund non-thickened membrane above.

Dade county: Cutler, Biscayne Bay, *H. J. Humm 10*, 13 Jan. 1946 (C, D). The Humm specimen was found with *Lyngbya confervoides* Gom.

17. *Lyngbya Diguetii* Gomont in Hariot, Jour. de Bot. 9: p. 169 (1895).

Filaments to 2 mm. long, forming a brilliant blue-green stratum, twisted at base, straight at ends, 2.5 - 3 microns wide. Sheath thin, turning blue

with chlor-zinc-iodine. Trichomes not constricted at cross-walls, 2-3 microns wide. Cells nearly quadrate or more rarely shorter than wide, 1-3.7 microns long. Apical cell rotund, calyptra absent.

Alachua county: Sink I, Hibiscus pk., Gainesville, *Brannon 10*, 29, 34, 177, Sept. 1949 (C, D). Citrus county: near Crystal river, *Schalbert 2070A*, 12 Mar. 1949 (C, D). Lee county: fresh-water pool, region of Hendry creek, about 10 miles south of Fort Myers, *Standley 73551*, 11 - 25 Mar. 1940 (C, D). Marion county: *Brannon 177*, 10 June 1943 (C, D). Wakulla county: shallow stream, 5.5 miles S.E. of Newport, St. Marks Wildlife Refuge, *Nielsen, Madsen & Crowson 32, 33*, March 1948 (C, D, F); Mounds pool, roadside ditch, St. Marks Wildlife Refuge, *Nielsen, Madsen & Crowson 125*, June 1948 (C, D, F); Little spring, Newport, *Nielsen, Madsen & Crowson 184*, July 1948 (C, D, F); on stones in outlet of large sulphur spring bathing pool about one mile north of Newport, *Drouet, Crowson & Thornton 11400*, 25 Jan. 1949 (C, D, F).

Plectonema Wollei Gom. and *Oscillatoria rubescens* Gom. were found in the collections.

18. *Lyngbya limnetica* Lemmermann. Bot. Centralbl. 76: p. 154 (1898).

Filaments straight or slightly curved, individual, free-floating, 1-2 microns wide. Sheath thin, hyaline. Cells 1-1.5 microns wide, 1-3 microns long, not constricted at cross-walls, with or without granules, pale blue-green.

Lake county: in shallow water, shore of Lake Harris, western part of municipal park, Leesburg, *Drouet & Brannon 11064*, 19 Jan. 1949 (C, D).

The following Florida collections have been referred as follows: (Drouet 1939): *Lyngbya pallida* (Naeg.) Kg. in Wolle, F. W. Alg. 298 (1887) to *Porphyrosiphon Notarisii* Gom.; *Lyngbya Naveanum* Grun. in Wolle, F. W. Alg. 298 (1887) to *Porphyrosiphon Notarisii* Gom.; *Lyngbya obscura* Wolle in Wolle, F. W. Alg. 298 (1887) to *Oscillatoria limosa* Gom.; *Lyngbya vulgaris* (Kg.) Kirch. in Wolle F. W. Alg. 300 (1887) to *Symploca Muscorum* Gom.; *Lyngbya Juliana* Menegh. in Wolle F. W. Alg. 301 (1887) and *Lyngbya lutea* (Agardh) Gom. in Tilden 114 (1910) have been re-examined by Drouet who states "that they are Myxophyceae in an unrecognizable state". *Lyngbya major* Meneghini in Tilden, Minn. Alg. I: 126

(1910) and *Lyngbya hyalina* Harvey in Tilden, Minn. Alg. I: 128 (1910) are Florida records for which specimens are lacking.

Lyngbya hyalina Harvey and *Lyngbya rosea* Taylor have been reported from Key West and Dry Tortugas by Taylor (1928).

(To be concluded in Vol. 18, No. 3)

MONOGENETIC TREMATODES OF GULF OF MEXICO
FISHES. PART VII

THE SUPERFAMILY DICLIDOPHOROIDEA Price, 1936

(Continued)¹

WILLIAM J. HARGIS, JR.
The Citadel, Charleston, South Carolina

This, the seventh paper of the present series treating the monogeneids of the Gulf of Mexico, deals with several species belonging to the genus *Mazocraeoides* Price, 1936 of the family Mazocraeidae Price, 1936. It continues presentation of the data concerning members of the suborder Polyopisthocotylea Odhner, 1912 obtained during a recently concluded study of these ectoparasites of fishes. The organization and purpose are the same as for preceding installments.

All measurements were made using the ocular micrometer and are cited in millimeters. In the cases of curved structures measurements are of lines subtending the greatest arcs of those structures. In the descriptions given below the mean is presented first, followed by the minima and maxima in parentheses. The number of measurements used to derive the mean is usually the same as the number of individuals measured; otherwise the actual number employed appears in parentheses before the measurements. All drawings were made with the aid of the camera lucida.

RESULTS

Suborder Polyopisthocotylea Odhner, 1912
Superfamily Diclidophoroidea Price, 1936
Family Mazocraeidae Price, 1936
Genus *Mazocraeoides* Price, 1936

In addition to the new species described herein, the genus *Mazocraeoides* contains *M. georgei* Price, 1936 and *M. dorosomatis* (Yamaguti, 1938) Sproston, 1946.

¹Contribution from the Biological Laboratories of the Citadel and the Oceanographic Institute of Florida State University, Tallahassee. Work aided by the Florida Academy of Science - A.A.A.S grant-in-aid for 1952.

Acknowledgments and dedication of the present installment are the same as for preceding ones.

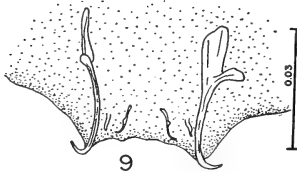
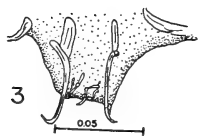
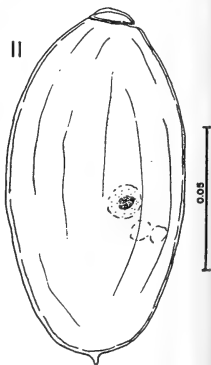
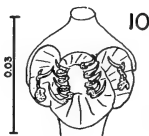
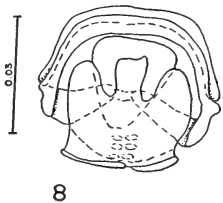
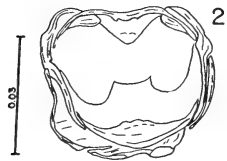
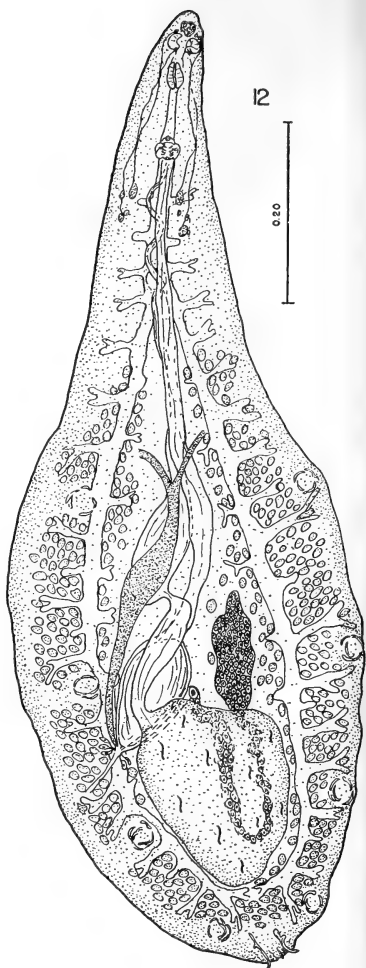
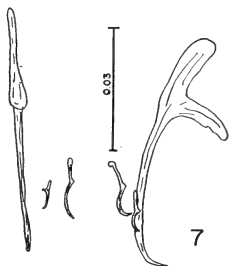
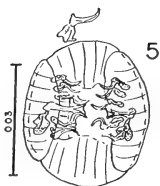
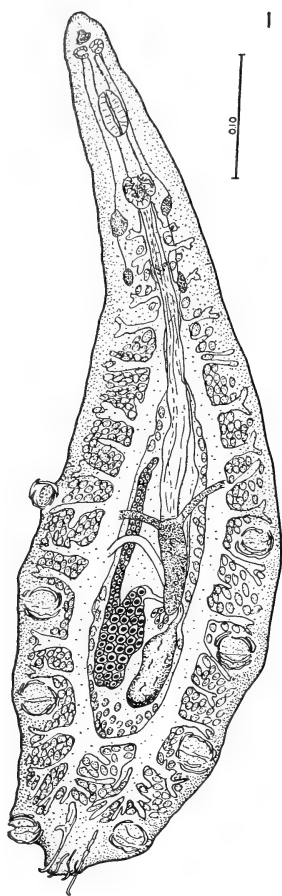

The unusual, somewhat clavate body shape of its members is so characteristic that the genus is easily recognized. However, despite its aberrant shape, its affinities with other mazocraeid genera, *e.g.* genital atrium armament, clamp structure and anchors, are clear.

All of the hosts bearing the known members of this genus belong to the suborder Clupeodei. *M. georgei* and *M. opisthonema*, described below, are the most closely related and occur on gills of members of the family Clupeidae. *M. dorosoma*, the most different one, is parasitic on *Dorosoma thrissa* a member of the clupeoidid family Dorosomidae.

Two redescriptions of *M. georgei* Price, 1936 are given below. The first is of the worms taken from *Brevoortia patronus* from the Gulf of Mexico and the second is of the worms from several *Pomolobus* spp. from the Atlantic Ocean. This is done with the hope that future studies of the group will be facilitated. The reasons underlying this action are: (1) the hosts belong to two different genera and occur in different localities, (2) certain small but constant morphological differences exist between the flukes which because of a dearth of specimens cannot now be regarded as species significant. Later studies may reveal further differences of either sub-specific or specific value.

Explanation of Figures

Mazocraeoides georgei from *Brevoortia patronus*

1. Whole mount, ventral view.
2. Clamp, open.
3. Enlargement of posterior end showing anchors.
4. Genital corona.

Mazocraeoides georgei from *Pomolobus pseudoharengus*

5. Genital corona, with free spine.
6. Clamp, open.
7. Anchors.

Mazocraeoides opisthonema n. sp.

8. Clamp, closed, ventral view.
9. Enlargement of posterior end showing anchors.
10. Genital corona.
11. Egg.
12. Whole mount, ventral view. Composite drawing of the body outline of one specimen and internal organs of another.

MAZOCRAEOIDES GEORGEI Price, 1936

(Figures 1-4)

Host: *Brevoortia patronus* Goode, Gulf Menhaden, a nerito-pelagic marine clupeid.

Location: Gills.

Locality: Alligator Harbor, Florida.

Previously reported hosts and locality: *Pomolobus pseudo-harengus* and *P. mediocris* from Woods Hole, Mass.

Number studied: 9.

Number measured: 5.

Redescription: Body clavate, 1.1 (0.7-1.3) long by 0.4 (0.2-0.5) wide, rounded and not flattened dorso-ventrally as Linton (1940) stated, anterior portion of body long and tapered, posterior end broad and bluntly rounded; opisthaptor not separated from body. Cuticle thin, with delicate anterior striae. Prohaptor a pair of buccal suckers placed laterally in the buccal funnel; cephalic glands opening via ducts to the buccal funnel; posterior-lateral to genital atrium. Opisthaptor consisting of 4 pairs of clamps ventro-lateral in posterior half of body and slight posterior extension of body bearing 3 pairs of anchors. Clamp structure difficult to discern because most views obtained are of the open edges; however, clamps analysable on one specimen showed the following: anterior clamps slightly larger than posterior, (10) 0.037 (0.030-0.045) long by 0.031 (0.026-0.041) wide; ventral loop continuous, dorsal loop elements apparently incomplete though prominent, middle loop complete, center piece sculptured. Anchors postero-medial to posterior clamps; largest anchors lateral, 0.055 (0.047-0.061) long, with stout shafts (deep roots) and sickle-shaped ends; intermediate anchors smallest, similar to larval hooks in other form, 0.007 (0.007-0.009) long; medial anchors, 0.018 (0.014-0.022) long, roots modified giving entire anchor a more or less S-shape. Mouth subterminal. Pharynx ovoid, 0.042 (0.041-0.043) long by 0.030 (0.027-0.036) wide; esophagus broad, ramified posterior to genital atrium, extending to one-third level of body. Gut bifurcate, crura ramified, rami mostly lateral, confluent posterior to testis. Testis saccate, postequatorial, to left of midline between intestinal crura, 0.256 long by 0.054 wide; vas deferens wide, slightly sinuous, in midline. Genital pore midventral, located at about the middle of the esophagus, opening into an armed genital atrium. Genital corona in three pieces; central, ring-like muscular piece, 0.026 (0.023-0.030) long by 0.022 (0.020-0.023) wide, armed medially by 5 pairs of small, dorsally curved spines, 0.005 (0.004-0.007) long; 2 laterally placed curved muscular pieces, 0.018 (0.015-0.019) long by 0.008 (0.007-0.009) wide, armed by a pair of larger, ventrally curved spines, 0.009 (0.007-0.012) long, with irregular bases. Ovary tubular, folded, to right of midline; oviduct extending medially from median end of ovary lobe. (Ovaries and testes in these forms difficult to discern and somewhat variable in shape and extent.) Ootype dorsal to vitelline reservoir; uterus proceeding anteriorly in midline. Genito-intestinal canal apparently curving medially from the right crus. Vaginal pore irregular in outline, middorsal, at posterior end of what often appears to be a long antero-dorsal groove; vaginal duct and internal connections not observed. Mehlis' gland present.

Vitellaria follicular, near intestinal crura, mostly between rami, from a level posterior to genital pore to near posterior end of body; transverse vitelloglands fusing in midline to form Y-shaped vitelline reservoir. Egg not observed.

Discussion: A description of *Mazocraeoides georgei* Price, 1936 was first published in a brief preliminary account and later redescribed and figured by Linton (1940) from the gills of two species of *Pomolobus* from Woods Hole, Mass. The specimens on which the present redescription is based were taken from the gills of a host belonging to the genus *Brevoortia* of the family Clupeidae. This pattern of parasite infection may reflect the relationship of the hosts. As mentioned above it is possible that subspecific or even specific differences exist between these *Brevoortia* parasites and those from *Pomolobus*.

MAZOCRAEOIDES GEORGEI Price, 1936

(Figures 5-7)

Hosts: *Pomolobus pseudoharengus* (Wilson), Alewife and *P. mediocris* (Mitchill), Hickory Shad, from Woods Hole, Mass.

Number studied and measured: 3.

Additional description: Body 1.9 (1.5-2.2) long by 0.7 (0.5-0.9) wide. Anterior clamps larger, (6) 0.045 (0.036-0.049) long by 0.038 (0.034-0.043) wide. Three pairs of anchors; lateral pair largest, 0.063 (0.061-0.065) long; intermediate anchors smallest, 0.012 (0.008-0.018) long; medial anchors, 0.015 (0.009-0.019) long. Pharynx ovoid, 0.054 (0.053-0.054) long by 0.041 (0.038-0.046) wide. Genital corona with three muscular pieces. Center part a ring-like muscular piece, (2) 0.034 (0.034-0.035) long by (2) 0.026 (0.026-0.027) wide, armed medially by three pairs of small dorsally curved spines, 0.007 (0.007-0.008) long; two curved muscular pieces, 0.024 long by 0.008 wide, armed with a pair of large, ventrally curved spines, 0.012 (0.009-0.017) long, these spines apparently not terminally forked. Testis saccate, lying to left of body, 0.329 (0.243-0.425) long by 0.144 (0.121-0.182) wide. Eggs *in utero* appear somewhat variable in shape, generally fusiform, (1) 0.167 long by (1) 0.109 wide; some with filaments at both ends, others with none.

Discussion: This study was made from several specimens on Linton's USNM Helm. Coll. slide No. 35623, and is given because of the lack of detail in previous descriptions.

These forms differ from those on *Brevoortia patronus* (described herein) in the following respects: (1) spines on reniform muscular genital pieces not forked distally, (2) bases of these same spines smaller and of a different shape, (3) shape of the posteriormost spines on ring-like muscular genital piece, (4) host. These differences may later be shown to be either subspecific or specific in stature.

MAZOCRAEOIDES OPISTHONEMA n. sp.

(Figures 8-12)

Host: *Opisthonema oglinum* Gill, Theard Herring, a nerito-pelagic marine clupeid.

Location: Gills.

Locality: Tampa Bay, Pinellas Co., Florida.

Number studied and measured: 3.

Holotype: USNM Helm. Coll.

Description: Body elongate, clavate, 1.1 long by 0.4 (0.4-0.5) wide, narrowed anteriorly, broadly rounded posteriorly, opisthaptor not separated from rest of body. Cuticle apparently thin and smooth. Prohaptor a pair of buccal suckers placed laterally in the buccal funnel; cephalic glands postero-lateral to genital aperture with ducts leading to structures that are probably small head organs near the buccal suckers. Opisthaptor 4 pairs of clamps ventro-lateral on the broadened posterior part of body, anterior clamps slightly larger, (4) 0.025 (0.020-0.027) long by 0.024 (0.022-0.026) wide; ventral loop continuous, dorsal loop elements incomplete, middle loop complete, center piece highly modified, clamp framework apparently much like that of other mazocraeid flukes though no favorable views were available. Anchors subterminal, 3 pairs; lateral anchors largest, 0.038 (0.036-0.039) long, shafts stout, ends sickle-shaped, intermediate anchors smallest, very delicate, appearing very unlike ordinary anchors in shape, 0.007 (0.007-0.008) long, somewhat like the bottle-shaped sclerites found on other monogeneids; medial anchors slightly sigmoid, 0.011 (0.008-0.013) long, with long shafts and delicate sickle-shaped ends. Mouth subterminal. Pharynx piriform to ovoid, 0.041 (0.032-0.050) long by 0.019 (0.019-0.020) wide; esophagus elongate, laterally ramified, extending to anterior one-fourth level of body. Gut bifurcated, crura ramified medially and laterally, rami forked, crura apparently not confluent posteriorly. Genital organs somewhat variable in shape and location, often difficult to discern. Testes large, saccate, roughly ovoid, between intestinal crura postequatorially, 0.256 long by 0.094 wide; proximal end of vas deferens a large tube of irregular caliber, expanding dorsal to vitelline reservoir to form a seminal vesicle, narrowing and becoming somewhat sinuous anteriorly. Genital pore midventral midway the esophagus, opening into the armed genital atrium. Genital corona in 3 parts; center part a ring-like muscular piece, 0.021 (0.019-0.022) long by 0.020 (0.019-0.020) wide, armed medially by 4 separate pairs of small spines, 0.005 long, the posteriormost spine bearing a smaller spine on its base thus making 5 pairs of spines in all; two lateral curved muscular pieces, 0.017 (0.015-0.019) long by 0.007 (0.007-0.008) wide, armed with a pair of ventrally curved spines, 0.007 (0.007-0.008) long, with long irregularly shaped bases. Ovary elongate, folded, lying to left and dorsal to testis; oviduct running dextrally from right ovarian lobe. Ootype obliquely mesial and dorsal to the vitelline reservoir; uterus proceeding in midline to genital pore. Genito-intestinal canal running from right crus to posterior end of vitelline reservoir. Vaginal pore middorsal to gut bifurcation, ducts not observed. Mehlis' gland around base of ootype. Vitellaria follicular, near intestinal crura, from level posterior to gut bifurcation to near posterior end of body; transverse vitelloducts fusing in midline to form obliquely situated, Y-shaped vitelline reservoir. Egg *in utero* elliptical in outline, (1) 0.123 long by (1) 0.068 wide, no terminal filaments on one egg examined.

Discussion: A study of *M. georgei* Price, 1936 and *M. dorosomatis* (Yamaguti, 1938) Sproston, 1946, the other species in this genus, indicates

that the present species is different from both, being apparently more closely related to the former. It differs from *M. georgei* in the following characters: (1) position and shape of ovary and testis, (2) number and arrangement of genital spines, (3) extent of vitelline reservoir, (4) host. Further study of these forms must be conducted in order to ascertain their true relationship since they are morphologically very similar.

The hosts of the two American species, *M. georgei* and *M. opisthonema*, both belong to the family Clupeidae.

SUMMARY

This paper has presented a short discussion of the monogeneid genus *Mazocraeoides* Price, 1936 and its species. *Mazocraeoides georgei* Price, 1936 has been redescribed and discussed, and *Mazocraeoides opisthonema* n. sp. described.

Part VIII of this series continues presentation of the data on the superfamily Diclidophoroidea Price, 1936.

LITERATURE CITED

LINTON, EDWIN

1940. Trematodes from fishes mainly from the Woods Hole region Massachusetts. *Proc. U. S. Nat. Mus.* 88: 1-172.

SOME RECORDS OF HEMIPTERA NEW TO FLORIDA

ROLAND F. HUSSEY

Biology Department, University of Florida

These records are based on specimens in the collections of the University of Florida (UF) and the Florida State Plant Board (SPB), together with some that are in my own collection.

ARADIDAE

Aradus (Quilnus) niger Stål

Four males were collected by me, November 21, 1953, under bark of a log in thinned-out woods beside "Falling Creek", about 4½ miles northeast of Lake City, in Columbia County. (UF).

LYGAEIDAE

Oedancala dorsalis (Say)

The first Florida specimens of this northern species were taken July 12, 1954, by F. W. Mead (SPB), from herbage on the Apalachicola River flood plain at Chattahoochee. In the northern states I have found *O. dorsalis* on herbage in notably damper situations than those frequented by its common southern relative *O. crassimana* (Fabr.)

ENICOCEPHALIDAE

Systelloderes inusitatus Drake & Harris

One specimen is at hand (UF), collected by Dr. F. N. Young, March 21, 1947, about one mile south of Elfers in Pasco County and about three miles north of Tarpon Springs. This is the first new locality record for the species since it was described in 1927 from Woodville, Mississippi.

As noted by its authors, this species has much more incrassate fore femora and much smaller eyes than *S. biceps* (Say). The eyes of *inusitatus*, as seen from the side, do not reach the level of either the dorsal or the ventral margin of the head, while in *S. biceps* they are continued onto its under side and are almost in contact on the mid-ventral line. Also, the short, erect pilosity on head (above and below), pronotum, and scutellum is much thicker in *inusitatus* than in *biceps*.

Although *S. biceps* is not new to the Florida list, it is worth noting that on April 3, 1955, in mid-afternoon, I found sparse

swarms of this species flying in a wet woodland beside the Santa Fe River at Blue Spring, in Gilchrist County.

REDUVIIDAE

Gardena poppaea McAtee & Malloch

One male of this species, previously known only from Texas, was taken by Dr. T. H. Hubbell, December 31, 1924, at Manatee (now incorporated in the city of Bradenton). The specimen (UF) is in fragments, but the characteristic male genitalia afford positive identification. Dr. Hubbell writes me that this emesine was collected at night in a subtropical hammock containing much cabbage palmetto.

Ghilianella productilis Barber

I collected two adults from junipers at Silver Glen Springs, near Lake George in Marion County, March 19, 1955, and I have a nymph that I took from Spanish moss at Lakeland, February 7, 1948. I have also seen specimens (SPB) from Brevard County, collected March 24, 1954, by F. W. Mead, and from Gainesville, October 1953, the latter taken on the University campus by Mr. T. W. Sistrunk. Though not new to Florida, this emesine has previously been reported only from the far southern part of the state and from Cuba.

ANTHOCORIDAE

Lasiochilus comitalis Drake & Harris

I have identified as this species a specimen collected in Alachua County, November 21, 1953, by F. W. Mead (SPB). Described in 1926 from specimens taken on hickory in North Carolina, *L. comitalis* has not been reported elsewhere until now.

MIRIDAE

Coccobaphes sanguinarius Uhler

Dr. H. V. Weems, Jr., collected two specimens of this bright red, maple-dwelling plant-bug in Highlands Hammock State Park, near Sebring, March 24, 1951.

HYDROMETRIDAE

Hydrometra hungerfordi Torre-Bueno

This species was wrongly identified by Herring (1949) as *H. australis* Say. In so doing he was misled by Torre-Bueno's wholly

erroneous remark that in *hungerfordi* the ante-ocular and post-ocular parts of the head are subequal in length, though the measurements in the original description show a ratio of 9:5 for these parts. The name *australis*, according to Drake and Hottes (1952), should be used for the species referred to by Herring and others as *H. myrae* Torre-Bueno. Mr. Herring's material in this genus is now deposited in the University of Florida collections.

GERRIDAE

Rheumatobates clanis Drake & Harris

Mr. Herring has given me several specimens from a series of this species which he took on salt water on the Gulf coast at Bayport, Hernando County, November 2, 1947, and has very kindly permitted me to publish this record together with two others which follow. *R. clanis* is new to the United States list, as it was known before only from British Honduras and from northwestern Cuba.

Rheumatobates minutus Hungerford

I collected several alate and partially de-alated specimens from a pool on the campus of Florida Southern College, at Lakeland, November 9, 1950; and Mr. Herring found this species on fresh water on Big Pine Key, Monroe County, November 11, 1947. It was known previously from Yucatán, Panamá, and Puerto Rico, and a subspecies occurs in Amazonas, Brasil, and in eastern Perú.

VELIIDAE

Microvelia portoricensis Drake

A number of specimens were taken with the preceding species by Mr. Herring on Big Pine Key, November 11, 1947. This veliid is another addition to the water-strider fauna of the United States.

LITERATURE CITED

DRAKE, C. J., and F. C. HOTTES

1952. Distributional and Synonymical Data and Description of Two New Hydrometridae. *Jour. Kansas Ent. Soc.*, 25(3): 106-110.

HERRING, JON L.

1949. Taxonomic and Distributional Notes on the Hydrometridae of Florida (Hemiptera). *Florida Ent.*, 1948, 31(4): 112-116.

Quart. Journ. Fla. Acad. Sci., 18(2), 1955.

EFFECT OF A LONG SHAFT ON THE POLARIZATION OF SKYLIGHT

A. G. SMITH and M. L. VATSIA

Department of Physics, University of Florida

One of the authors (Smith, 1955) has shown elsewhere that a long shaft, such as a chimney, has no appreciable effect on the luminance and color of the daytime sky. Thus, there is no *physical* basis for the common belief that it is possible for an observer at the bottom of such a shaft to see stars during the day. While available physiological data are (as usual) less conclusive, there is a considerable volume of observational evidence which suggests that the shaft will hinder, rather than aid, the observer in achieving optimum visual adaptation. It thus appears unlikely that there is any real basis for this suprisingly widespread belief.

It occurred to the writers that there is an additional important property of skylight which had been neglected in the original investigation, since it does not bear directly on the visual problem.

The light of the sky, like all scattered radiation, is plane polarized in varying degrees, the extent of the polarization depending upon the angular relationship between the sun, the observer, and the area of the sky being studied. It was decided, for the sake of completeness, to undertake measurements of sky polarization from the 157-foot chimney used in the previous program.

The instrument used in the investigation was a 3-inch zenith telescope of 15-inch focal length. The photomultiplier tube of a Photovolt Model 520-A photometer was placed at the primary focus of the telescope. Immediately preceding the photomultiplier was the analyzer, a 2-inch disc of Polaroid material. (In one of the runs the Polaroid was replaced by a large Nicol prism.) Optical bench tests showed that in the crossed position Polaroids of this type transmit only about 0.25 per cent of incident light of the spectral quality of skylight. Sky measurements were made in pairs, with the telescope set up first inside the chimney and then outside; on the average about five minutes elapsed between the two readings of a pair. During each of several runs the percentage polarization of the zenith sky was measured in this fashion for periods ranging from 4 hours to 12 hours.

Figure 1 shows the results of the run of March 11, 1955, which is typical of the data. In this figure, percentage polarization is plotted against time and against solar altitude. (The solar altitude

was computed from astronomical tables.) Since sky polarization is a maximum in the region 90° from the sun, the zenith polarization is of course greatest near sun-up and sun-down. It is clear that both sets of points lie on a single curve, within the scatter to be expected from random errors, and that there is thus no systematic difference between readings taken through the chimney and those taken outside. The measurements, therefore, emphasize the fact that even a shaft as long as this one in no way alters the physical properties of the light from the sky.

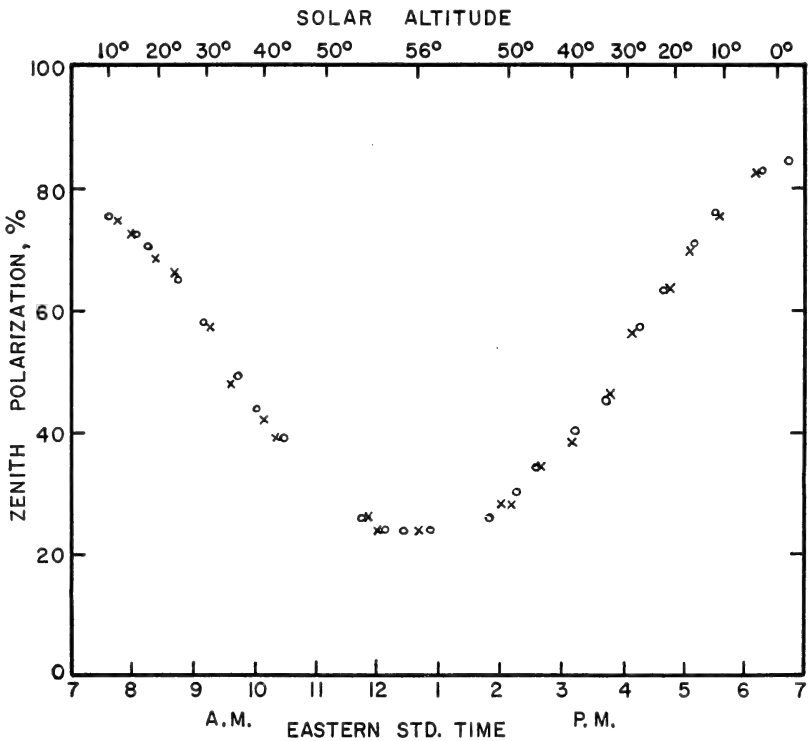

Fig. 1.—Run of March 11, 1955. Circles are observations made through chimney; crosses are observations made outside chimney.

LITERATURE CITED

SMITH, ALEX G.

1955. Daylight Visibility of Stars from a Long Shaft. *J. Optical Soc. of America* (in press).

Quart. Journ. Fla. Acad. Sci., 18(2), 1955.

BOOK REVIEW

A MANUAL OF THE DRAGONFLIES OF NORTH AMERICA (ANISOPTERA). (Including the Greater Antilles and the Provinces of the Mexican Border.) By James G. Needham and Minter J. Westfall, Jr. xi + 615 pp., col. front. 341 figs. Univ. of California Press, Berkeley and Los Angeles, 1955. \$12.50.

To many people, the dragonflies are one of the most fascinating groups of living insects. Their effortless flight, brilliant colors, and complex behavior attract the attention and admiration of laymen and professional scientists alike. To judge from their book, the dragonflies have meant even more to Drs. Needham and Westfall. One is endlessly impressed by the vast amounts of loving labor which have gone into the preparation of this great volume. The minute attention to detail is matched by the completeness of the coverage and the lucid yet vivid language. Even admitting that the probable descendents of the giant protodonates of the Coal Age swamps are worth attention, the scope and perfection of this book is still amazing.

The "Manual of the Dragonflies . . ." is a literary descendent, in a sense, of the now classical and almost unobtainable "Handbook of the Dragonflies of North America" by Needham and Hortense Butler Heywood (1929). It is to be completed in a proposed second volume on the damsel flies by Dr. Westfall. The amount of new material and more extended coverage dictated a number of economies and precluded treatment of the entire order in one book. The result, however, is not entirely unfortunate since the Anisoptera form a natural group very easily distinguished from the damselflies, and an authoritative work on their classification satisfies a very real need.

The general plan is to present through carefully constructed dichotomous keys and tables of characters the means of distinguishing both adults and nymphs, where known, of the five families, 71 genera, and 332 species recorded from the region covered. The inclusion of the Greater Antilles and northern Mexico is an advance over many manuals on other groups which persist in stopping at the arbitrary southern border of the United States. Each genus and species is discussed separately and in considerable detail. The portion on systematic classification is preceded by a discussion of characters and adequate figures so that even the amateur should

be able to use the keys with a fair promise of success. I must admit, however, that they do not work on memories, and I have been quite unable to determine the possessor of the brilliant red abdomen which I have seen so often along the canals of the Everglades.

The most notable feature of the new book is the many fine illustrations, both photographic and line, which were largely prepared by the junior author. With their aid, the use of the keys and tables should attain a high degree of accuracy.

As to the format and printing, they are imposing. It is only to be regretted that they seem to have caused the omission of biological and distributional notes which would have added greatly to the over-all usefulness of the book. To a field naturalist, who does not have time constantly to search the vast literature, the lack of summaries of previous work is at least inconvenient. The price is also discouraging.

The interested reader will find a stimulating review by C. Francis Byers in the March, 1955, issue of the *Florida Entomologist*. Dr. Byers, who has contributed largely to our knowledge of the Florida fauna, presents many interesting aspects of the historical development of the study of dragonflies. He says in part:

The pattern for the development of our knowledge of North American Odonata culminating in the Needham-Westfall volume was set in substantially its present form through the works of H. A. Hagen and the Baron de Selys-Longchamps a hundred years ago. The late E. B. Williamson and Clarence Kennedy together with Drs. P. P. Calvert, E. M. Walker, and J. G. Needham developed and extended this tradition through the early part of the 20th century. These men directly, and through their students, over the years have extended our knowledge of the North American fauna to a point where new vistas must be opened and investigations along different lines initiated.

The new lines of investigation have already been begun and the new vistas are opening. A report on the fantastic mating system in *Plathemis lydia* by Merle E. Jacobs is promised in a forthcoming issue of *Ecology*, and other aspects of dragonfly behavior are being investigated both in the United States and abroad. In the development of this work the "Manual" will play an indispensable part.

All in all, the "Manual of the Dragonflies of North America" is a splendid book. It represents the apex of achievement of a synthesis of our knowledge on a very important group of insects.

This synthesis was only possible through the "know how" of an "old master" and the diligent cooperation of his younger colleague. It is regrettable that Dr. Needham did not live to see the publication of what he must have felt was one of the justifications of his life's work.—FRANK N. YOUNG, *Indiana University*.

THE FLORIDA ACADEMY OF SCIENCES

ORGANIZATION FOR 1955 ANNUAL MEETING AT THE UNIV. OF MIAMI

Local Arrangements Committee: Dr. W. Henry Leigh,* chairman; Dr. Alfred P. Mills, visual aids; Dr. Jackson P. Sickels, campus information; Dr. Virgil Sleight, accommodations; Dr. Ruth Clouse, banquet arrangements; Mr. Oscar Owre, exhibits.

Awards Committee: Dr. Clarence P. Idyll,* Marine Laboratory, chairman; Dr. Luella Dambaugh, Geography; Dr. Harry Robertson, Physics.

Membership Committee: Dr. Howard K. Wallace, University of Florida, chairman.

Collegiate Academy Sponsorship: Dr. R. S. Kiser,* Florida Southern, chairman; Dr. Luella Dambaugh, local chairman.

Junior Academy Sponsorship: Miss Louise Williams,* Lakeland High, chairman.

Conservation Committee: Dr. Benjamin B. Leavitt,* University of Florida, chairman; the Academy's president, vice president, and all past presidents willing to serve; Mr. Robert P. Allen, Tavernier; Dr. O. Earle Frye, Jr., Tallahassee; Mr. Robert M. Ingle, Tallahassee; Dr. Maurice W. Provost, Vero Beach.

Science Fairs Committee: Prof. Clyde T. Reed,* University of Tampa, chairman; Dr. Alfred P. Mills, University of Miami; Dr. Chester S. Nielsen, Florida State University; Dr. Dan A. Thomas, Rollins College; Dr. Gerald A. Thomas, University of Florida.

Florida Academy of Sciences Council (additional to those asterisked above): Dr. Joseph Curtis Moore, president; Dr. Howard K. Wallace, vice president and master of ceremonies; Dr. Sigismond deR. Diettrich, past president; Dr. Chester S. Nielsen, past president; Dr. Richard A. Edwards, secretary-treasurer; Dr. Ralph N. Yerger, chairman, the Biological Sciences Section; Dr. Harry Robertson, chairman, the Physical Sciences Section; Dr. Burke Vanderhill, chairman, the Social Sciences Section; Dr. Murray Sanders, chairman, the one-year trial Medical Sciences Section; Dr. Grace Madson, at large; Mr. J. P. Lesperance, at large; Dr. E. Ruffin Jones, AAAS Academy conference representative; Dr. A. M. Winchester, AAAS council representative; Dr. J. C. Dickinson, Jr., editor of the Quarterly Journal.

* Also member of Council.

INSTRUCTIONS FOR AUTHORS

Contributions to the JOURNAL may be in any of the fields of Sciences, by any member of the Academy. Contributions from non-members may be accepted by the Editors when the scope of the paper or the nature of the contents warrants acceptance in their opinion. Acceptance of papers will be determined by the amount and character of new information and the form in which it is presented. Articles must not duplicate, in any substantial way, material that is published elsewhere. Articles of excessive length, and those containing tabular material and/or engravings can be published only with the cooperation of the author. Manuscripts are examined by members of the Editorial Board or other competent critics.

MANUSCRIPT FORM.—(1) Typewrite material, using one side of paper only; (2) double space *all* material and leave liberal margins; (3) use 8½ x 11 inch paper of standard weight; (4) do not submit carbon copies; (5) place tables on separate pages; (6) footnotes should be avoided whenever possible; (7) titles should be short; (8) method of citation and bibliographic style must conform to JOURNAL style—see Volume 16, No. 1 and later issues; (9) a factual summary is recommended for longer papers.

ILLUSTRATIONS.—Photographs should be glossy prints of good contrast. All drawings should be made with India ink; plan linework and lettering for at least ½ reduction. Do not mark on the back of any photographs. Do not use typewritten legends on the face of drawings. Legends for charts, drawings, photographs, etc., should be provided on separate sheets. Articles dealing with physics, chemistry, mathematics and allied fields which contain equations and formulae requiring special treatment should include India ink drawings suitable for insertion in the JOURNAL.

PROOF.—Galley proof should be corrected and returned promptly. The original manuscript should be returned with galley proof. *Changes* in galley proof will be billed to the author. Unless specially requested page proof will not be sent to the author. *Abstracts* and *orders for reprints* should be sent to the editor along with corrected galley proof.

REPRINTS.—Reprints should be ordered when galley proof is returned. An order blank for this purpose accompanies the galley proof. The JOURNAL does not furnish any free reprints to the author. Payment for reprints will be made by the author directly to the printer.



506.73
.F6F6E



Quarterly Journal

of the

Florida Academy of Sciences

Vol. 18

September, 1955

No. 3

Contents

Wass—The Decapod Crustaceans of Alligator Harbor and Adjacent Inshore Areas of Northwestern Florida	129
Nielsen—Florida Oscillatoriaceae III	177
Becknell—American Education and the Stone Wall	189
Kilby and Caldwell—A List of Fishes from the Southern Tip of the Florida Peninsula	195
Neill and Allen—Metachrosis in Snakes	207
Flavin and Edson—A Biological Soil Test for Available Phos- phorus by Spontaneous Growth of Soil Organisms	216
Klein—Hermaphroditism in a Mouse Related to Strain A	223

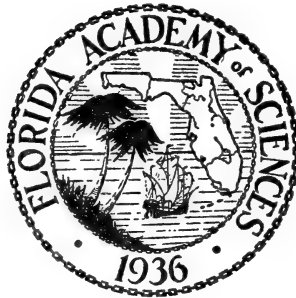

VOL. 18

SEPTEMBER, 1955

No. 3

QUARTERLY JOURNAL OF
THE FLORIDA ACADEMY OF SCIENCES

A Journal of Scientific Investigation and Research

Editor—J. C. DICKINSON, JR.

Associate Editor—JOHN D. KILBY

Published by the Florida Academy of Sciences

Printed by the Pepper Printing Co., Gainesville, Fla.

The business offices of the JOURNAL are centralized at the University of Florida, Gainesville, Florida. Communications for the editor and all manuscripts should be addressed to the Editor, Department of Biology. Business communications should be addressed to R. A. Edwards, *Secretary-Treasurer*, Department of Geology. All exchanges and communications regarding exchanges should be addressed to The Gift and Exchange Section, University of Florida Libraries.

Subscription price, Five Dollars a year

Mailed November 30, 1955

THE QUARTERLY JOURNAL OF THE FLORIDA ACADEMY OF SCIENCES

VOL. 18

SEPTEMBER, 1955

No. 3

THE DECAPOD CRUSTACEANS OF ALLIGATOR HARBOR AND ADJACENT INSHORE AREAS OF NORTHWESTERN FLORIDA¹

MARVIN L. WASS

Oceanographic Institute, Florida State University, Tallahassee, Fla.

The general paucity of organized information on the decapod Crustacea of the northeastern Gulf coast and the evidence that inshore waters of the area support a rich fauna led the writer to undertake this study. The work was begun in the summer of 1952 and completed a year later. Data has been gathered on the distribution and habitats of the *Decapoda* of shallow waters in the general area of Alligator Harbor, Franklin County, Florida, and a key has been prepared to the species collected.

HISTORICAL

Among the earliest collections of marine Crustacea from Florida is that made by Professor H. E. Webster, reported by Kingsley (1879). Webster collected along the Gulf coast south of Sarasota. Ives (1891) lists some decapods collected between Cedar Keys and the mouth of the Caloosahatchie river in 1886. Hemphill did considerable collecting south of Cedar Keys, and Stearns, who obtained most of his material from fish stomachs, was the source of many records from Pensacola prior to 1900; both of these collections were reported on in part by Rathbun (1918, 1925, 1930, 1937).

Offshore collections were made by the *Albatross* in 1885 and by the *Fish Hawk* in 1901 and 1902. The *Pelican* made some collections in 1939, but apparently only the shrimps of the family *Palaemonidae* have been reported on (Holthuis, 1951, 1952).

¹ Contribution No. 37, Oceanographic Institute, Florida State University.

Burkenroad (1934, 1939) has made important contributions concerning the family *Penaeidae* in the Gulf, mostly off Louisiana. Schmitt (1935a) described two new species of mud shrimps from Grande Isle; both are abundant along Alligator Point. A list of the fauna of the Grande Isle region (Behre, 1950) included 69 species of decapods. Chace (1942) described two small shrimps from Sanibel Island; one of these is common in Alligator Harbor. McRae (1950) studied the xanthid crabs of the Cedar Key area.

One of the few thorough studies of a decapod fauna comparable to that found in the northeastern Gulf is the survey of the species found at Beaufort, North Carolina, by Hay and Shore (1918).

THE AREA STUDIED

All decapods reported here were collected in water less than about 35 feet deep off Franklin and Wakulla counties in northwestern Florida. In certain areas, including Alligator Harbor, the Gulf beach of Alligator Point, the bottom near whistle buoy 26 (about 10 miles southeast of Alligator Point), and the area near St. Marks Light, collecting was more intensive than it was in other parts of the region.

Alligator Harbor is a shallow bay, open only at one end, formed by Alligator Point. The salinity is essentially the same as that of adjacent inshore Gulf waters, as there are no important freshwater streams entering the bay. Salinity records usually range from 28 to 34 points per thousand. The bottom is principally muddy sand and supports extensive beds of marine phanerogams of three species, *Thalassia testudinum* Koenig and Sims, *Cymodocea manatorum* Aschers, and *Halodule wrightii* Aschers. Much of the upper (eastern) part of the bay is covered by algae, often unattached, of the genus *Cladophora*. During spring and summer *Spyridia* and *Chondria* are abundant. Intertidal oyster bars occur along the mainland shore of the bay opposite the Alligator Harbor Laboratory. Drum Creek is a meandering tidal stream that originates in a salt marsh behind Drum Point just west of the laboratory.

The Gulf beaches of Alligator Point and Dog Island, about 10 miles southwest, were the source of several species not found elsewhere. Rocky spots in 8-10 feet of water 4-5 miles ESE of St. Marks Light were an important source.

Whistle buoy 26, about 10 miles southeast of Alligator Point in the open Gulf, marks an area of scattered sponges and coral heads in 30 to 35 feet of water where many species were collected.

Much collecting was done by means of dredges, trawls, and diving equipment operated from aboard the laboratory motor vessels *Sea Quest* and *Dolphin*. Fish stomachs from offshore were occasionally examined. Burrowing species were obtained by digging and by collecting in the surf.

KEY TO THE DECAPOD CRUSTACEA OF THE
ALLIGATOR HARBOR AREA ²

- 1. General form shrimp-like; cephalothorax and abdomen usually compressed laterally. (Suborder Natantia) 2
 General form lobster-like or crab-like; cephalothorax and abdomen usually depressed. (Suborder Reptantia) 29
- 2. Pleura of second segment of abdomen not overlapping those of the first segment. (Tribe Panaeidea) 3
 Pleura of second segment of abdomen overlapping those of the first segment. (Tribe Caridea) 10
- 3. First three pairs of legs chelate, all of the legs well developed
 PENAЕIDAE 4
 None of the legs chelate, last two pairs small or wanting...SERGESTIDAE
Lucifer faxoni
- 4. Integument thin; abdomen smooth, not carinate anteriorly 5
 Integument rigid; abdomen more or less carinate throughout its length and marked with furrows 8
- 5. Endopodite of first maxilla elongate and segmented; rostrum with ventral teeth 8
 Endopodite of first maxilla short and unsegmented; rostrum without ventral teeth 7
- 6. Dorsal carina about 2/3 length of carapace, with bordering lateral grooves about 1/2 length of carapace; flagellum of second antenna twice the body length *Penaeus setiferus*
 Dorsal carina of carapace extending from rostrum nearly to posterior margin and bordered on each side by a deep groove; flagellum of second antenna less than twice the body length *Penaeus duorarum*
- 7. Rostrum with long styliform tip, five dorsal teeth near base; posterior pereopods with long feeler-like tips *Xiphopeneus kroyeri*

² Only a small part of the material in this key is strictly original. Most of it has been compiled from keys or descriptive material published by the following authors: Anderson and Lindner, 1943; Burkenroad, 1934, 1939; Chace, personal communications; Coutiere, 1909; Hay and Shore, 1918; Holthuis, 1951, 1952; Lunz, 1937, 1945; Rathbun, 1918, 1925, 1930, 1933, 1937; and Schmitt, 1930, 1935a, 1935b.

(A glossary of terms used will be found at the end of this key.)

- Rostrum short and bearing usually 7 (7-9) equidistant teeth above; posterior pereopods not feeler-like *Trachypeneus constrictus*
8. A sharp spine on anterior margin of carapace below eye; dorsal carina of second abdominal segment not notched 9
 Angle below eye unarmed; a notch in dorsal carina of second abdominal segment *Sicyonia laevigata*
9. Dorsal carina of carapace with 3 or 4 teeth behind orbital margin, of which 3 are large and placed far behind orbit *Sicyonia brevirostris*
 Dorsal carina of carapace with 2 or 3 teeth behind orbital margin, of which 2 are large and placed far behind orbit *Sicyonia typica*
10. Carpus of second pair of legs annulated 11
 Carpus of second pair of legs not annulated PALAEMONIDAE 23
11. Eyes covered by the carapace CRANGONIDAE 12
 Eyes not covered by the carapace HIPPOLYTIDAE 18
12. Hand of large cheliped compressed; species most common in shallow water 13
 Hand of large cheliped cylindrical; species usually found in deeper water 14
13. Orbital lobes forming tooth-like projections; propodus of major cheliped not notched below *Alpheus normanni*
 Orbital lobes rounded; propodus of major cheliped notched on both margins *Alpheus heterochaelis*
14. Dactyls of last three pairs of feet with two unequal hooks, ventral hook always stronger *Synalpheus fritzmuelleri*
 Dactyls with two hooks approximately equal in width at base 15
15. Dactyls long and slender, hooks directed with the axis of the dactyl, little curved, the dorsal hook longer 16
 Dactyls short, hooks strongly curved, nearly equal in length 17
16. Frontal teeth longer than wide and spinous *Synalpheus townsendi*
 Frontal teeth squarish *Synalpheus minus*
17. Fingers of the small chela each armed with three strong flat teeth, crossed in a vertical plane; movable finger of the large hand greatly over-reaching the immovable finger *Synalpheus pectiniger*
 Fingers of the small chela with only two teeth; movable finger of the large hand little longer than the immovable finger
 *Synalpheus longicarpus*
18. Carpus of second pair of legs with two to five annuli 19
 Carpus of second pair of legs with many annuli
 *Hippolysmata wurdemanni*
19. Rostrum exceeding the eyestalks 20
 Rostrum not exceeding the eyestalks *Thor floridanus*
20. Series (5-9) of small spines along anterior margin of carapace below the eye 21
 Single spine on carapace behind base of antenna but none below that 22

21. Carapace and rostrum unarmed above except for a small median spine on gastric region *Latreutes fucorum*
Carapace strongly humped and armed with five or six spiniform teeth, first at about the middle of the carapace, last above the cornea
..... *Latreutes parvulus*
22. Rostrum almost twice as long as carapace proper, smooth above, serrate below *Angasia carolinense*
Rostrum much shorter, with two or three spines above and three below
..... *Hippolyte pleuracantha*
23. Propodi of second pair of legs swollen markedly 24
Propodi of second pair of legs not swollen 25
24. One hand enlarged much more than the other..... *Periclimenaeus wilsoni*
Both hands swollen to a lesser extent *Typton tortugae*
25. Rostrum with teeth above and below 26
Rostrum unarmed below except for one or two minute teeth near tip
..... *Periclimenes longicaudatus*
26. Rostrum directed straight forward, not noticeably upcurved, armed with 2 - 5 teeth below 27
Rostrum upcurved distally, armed with 5 - 9 teeth below
..... *Palaemon floridanus*
27. Second pair of legs long, with both fingers notched on inner edges, causing a conspicuous gap *Periclimenes americanus*
Second pair of legs normal; shrimps more common in brackish waters 28
28. Dorsal teeth of rostrum reaching up to apex which often is bifid
..... *Palaemonetes intermedius*
Dorsal margin of rostrum with an unarmed stretch before tip, thereby dagger-shaped *Palaemonetes pugio*
29. Carapace not fused with the epistome; antennae inserted laterad to the eyes; uropods present (except in Lithodidae), but often greatly modified. (Tribe Anomura) 30
Carapace fused with the epistome, at least at the sides; antennae inserted mediad to the eyes; uropods usually absent, rarely vestigial (Dromiidae and Dynomenidae). (Tribe Brachyura) 49
30. Abdomen symmetrical and covered with an exoskeleton for the most part 31
Abdomen unsymmetrical and generally unprotected; tail fan adapted for holding the body in hollow objects PAGURIDAE 40
31. Abdomen flexed beneath the cephalothorax; cephalothorax depressed or subcylindrical 32
Abdomen extended, lobster-like; cephalothorax compressed laterally
..... CALLIANASSIDAE 33
32. Second to fourth legs normal, crab-like; tail fan well developed and adapted for swimming PORCELLANIDAE 35
Second to fourth legs with the last joint curved and flattened; tail fan not adapted for swimming. (Superfamily Hippidea) 48

33. Rostrum small; chelipeds dissimilar and unequal 34
 Rostrum large; chelipeds similar and subequal *Upogebia affinis*
34. Inner uropods narrow, about four times as long as broad
 *Callianassa islagrande*
 Inner uropods about twice as long as greatest width
 *Callianassa jamaicensis louisianensis*
35. Carapace depressed; cheliped large 36
 Carapace subcylindrical, much longer than broad; chelipeds small
 *Euceramus praelongus*
36. Carapace subcircular, about as broad as long; chelipeds broad and flat 37
 Carapace oval, broader than long; hands slender and distorted
 *Polyonyx macrocheles*
37. Basal article of antenna little developed, flagellum not excluded from the orbit 38
 Inner angle of basal article of antenna expanded to meet the superior margin of the carapace, excluding the flagellum from the orbit 39
38. Body and appendages comparatively smooth *Porcellana sayana*
 Body and legs with numerous tuberculate elevations *Porcellana sorjata*
39. Carpus armed with three, low, distant, spine-tipped teeth
 *Petrolisthes armatus*
 Carpus armed with four teeth or lobes, not including antero-external angle *Petrolisthes galathinus*
40. Chelipeds subequal, or the right one is slightly larger than the left 41
 Left cheliped much larger than the right 45
41. Paired appendages absent on the first abdominal segment of both sexes 42
 Paired appendages present on the first two abdominal segments of the male and, in most species, on the first segment of the female 44
42. Fingers of chelipeds opening and closing horizontally 43
 Fingers opening and closing obliquely or nearly vertically
 *Petrochirus bahamensis*
43. Fingers spooned; antennal flagellum long and not setose
 *Clibanarius vittatus*
 Fingers acuminate; antennal flagellum short and much ciliated
 *Isocheles wurdemanni*
44. Rostrum prominent; paired appendages present on first abdominal segment of female; head appendages white, ringed with black
 *Paguristes tortugae*
 Rostrum rudimentary; no paired appendages on abdomen of female; conspicuous blue spot, bordered distally with black, white, and yellow, on merus of chela *Paguristes hummi*
45. Eyestalks with cornea dilated 46
 Eyestalks with cornea not dilated *Pagurus annulipes*

- 46. Hands broad and flat 47
 Hands subcylindrical; chelipeds slender *Pagurus longicarpus*
- 47. Chelae light-colored, with flat surface *Pagurus floridanus*
 Chelae brick red, a pit or dimple on surface of each at base of im-
 movable finger *Pagurus impressus*
- 48. First pair of legs simple, carapace subcylindrical HIPPIDAE
 *Emerita talpoida*
 First pair of legs subchelate; carapace depressed. ALBUNEIDAE
 *Lepidopa benedicti*
- 49. Anterior thoracic sterna not unusually broad, posterior thoracic sterna
 not keel-like 50
 Anterior thoracic sterna very broad, posterior thoracic sterna narrow
 and keel-like. RANINIDAE *Ranilia muricata*
- 50. Mouth field prolonged forward to form a groove 51
 Mouth field roughly quadrate 54
- 51. Front of body not specially produced and upturned; eyes of normal
 size. CALAPPIDAE 52
 Front of body produced into a projecting, upturned mass, bearing the
 small eyes closer together. LEUCOSIIDAE 53
- 52. Posterolateral region of the carapace expanded and dentate
 *Calappa flammea*
 Posterolateral region of the carapace not expanded
 *Hepatus epheliticus*
- 53. Only three spines on posterior and lateral margins of the carapace
 *Persephona punctata aquilonaris*
 Nine short lateral and posterior tubercles *Persephona crinita*
- 54. Last pair of legs abnormal, dorsal. DROMIIDAE 55
 Last pair of legs normal 56
- 55. Carapace convex, pilose *Dromidia antillensis*
 Carapace flat, membranous above *Hypoconcha arcuata*
- 56. Carapace circular or quadrate, usually broader than long; rostrum
 wanting 57
 Carapace, triangular, with the apex projecting forward and forming a
 rostrum 95
- 57. Free-living crabs with well-developed eyes and firm, hard carapace 58
 Small commensal crabs with very small eyes and orbits 86
- 58. Carapace elliptical, rounded anteriorly 59
 Carapace approximately quadrilateral, front region curved downward 78
- 59. Distal articles of last pair of legs flattened for swimming.
 PORTUNIDAE 60
 Distal articles of last pair of legs not flattened. XANTHIDAE 66
- 60. Carapace very broad, antero-lateral teeth nine 61
 Carapace not very broad, antero-lateral teeth five
 *Ovalipes ocellatus guadulpensis*

61. Palate with a longitudinal ridge; color in life, various hues of green, blue, and brown 62
 Palate without a longitudinal ridge; color in life, cream with brick red spotting *Arenaeus cribrarius*
62. Abdomen of male triangular 63
 Abdomen of male J-shaped, last two segments much narrower than the basal segments 65
63. Carapace wide; antero-lateral margin the arc of a circle whose center is near the posterior margin of the carapace; a round bare spot on postero-lateral slope of carapace *Portunus gibbesi*
 Carapace narrow; antero-lateral margin the arc of a circle whose center is near the center of the cardiac region; no round bare spot on postero-lateral slope of carapace 64
64. Interocular teeth eight, the inner orbital bilobed.....*Portunus spinimanus*
 Interocular teeth six, the inner orbital tooth entire
 *Portunus depressifrons*
65. Frontal teeth, including the inner orbitals, four *Callinectes sapidus*
 Frontal teeth, including the inner orbitals, six *Callinectes danae*
66. Frontal margin not transversely grooved 67
 Frontal margin transversely grooved *Leptodius floridanus*
67. Ambulatory legs and carapace not markedly spinulose, granular, or hairy 68
 Ambulatory legs usually spinulose, granular, or hairy 75
68. Carapace more or less hexagonal; anterolateral teeth well developed 69
 Carapace transversely oval; anterolateral teeth not strong; fingers of minor cheliped spooned *Eurypanopeus depressus*
69. Movable finger of major chela with large basal tooth 70
 Movable finger of major chela without large basal tooth
 *Neopanope texana texana*
70. Anterolateral teeth sharp-pointed 71
 Anterolateral teeth not sharp-pointed 74
71. Carapace crossed by broken, transverse, raised, granulated lines on anterior half 72
 Carapace not crossed by transverse raised lines 73
72. Sixth segment of male abdomen much broader than long; chelipeds very unequal, color of immovable finger running slightly back on palm; fingers of minor cheliped partially spooned *Panopeus turgidus*
 Sixth segment of male abdomen very little broader than long; color of immovable fingers running well back on palm in male; fingers of minor cheliped not spooned *Panopeus herbsti*
73. Front arcuate, forming a regular curve with anterolateral margins. Second anterolateral tooth lobiform, separated from the first by a shallow sinus *Neopanope packardi*
 Front narrow and extending beyond curve of anterolateral margins. Anterolateral teeth evenly produced *Hexapanopeus angustifrons*

74. Third to fifth segments of male abdomen fused; fingers white
 ----- *Eurytium limosum*
 All seven segments of male abdomen distinct; fingers black
 ----- *Menippe mercenaria*
75. Anterolateral borders with spines or spine-tipped teeth 76
 Anterolateral teeth not spine-tipped *Micropanope pusilla*
76. Carapace and chelipeds spinulose 77
 Carapace granulose anteriorly, pubescent posteriorly; chelipeds granu-
 lose *Lobopilumnis agassizi*
77. Two or more superhepatic spines; long spines dark-colored; ground
 color varying from orange in young to dark red in adults
 ----- *Pilumnus sayi*
 No superhepatic spines; major palm smooth or bare on outer surface;
 ground color more drab *Pilumnus dasypodus*
78. Carapace with three, sharp anterolateral spines. Species found in water.
 GONEPLACIDAE *Euryplax nitida*
 Anterolateral spines minute. Species normally found on land 79
79. Front broad, eyestalks of moderate length or short; outer maxillipeds
 do not conceal central part of mouth opening. GRAPSIDAE 80
 Front of moderate width, eyestalks long; outer maxillipeds almost com-
 pletely conceal mouth opening. OCYPODIDAE 81
80. Lateral margin of carapace with a tooth behind the outer orbital tooth;
 body strongly convex above; inhabits salt marshes .. *Sesarma reticulatum*
 Lateral margin of carapace without a tooth behind the outer orbital
 tooth; body nearly flat above; inhabits beaches above the drift line
 ----- *Sesarma cinereum*
81. Eyestalks slender; chelipeds of male very unequal 82
 Eyestalks stout; chelipeds of male nearly equal *Ocypode quadratus*
82. Anterior part of side margins convex and curving gradually back-
 wards 83
 Anterior part of side margins almost straight, continuing backward with
 an angular turn *Uca speciosa*
83. An oblique tuberculate ridge on inner surface of larger palm of male
 extending upward from lower margin 84
 No oblique tuberculate ridge on inner surface of palm *Uca pugilator*
84. Front wide, at least 1/3 of fronto-orbital width; leg joints red; found
 along brackish streams *Uca minax*
 Front narrower; less than 1/3 of fronto-orbital width; carapace in life,
 greenish black; lives in muddy areas *Uca pugnax rapax*
85. Dactyli of the walking legs simple, acute 86
 Dactyli of first three walking legs bifurcate 93
86. Third walking leg little, if any, longer than the other legs 87
 Third walking leg longer and stronger than the others, often consider-
 ably so 88

87. Palpus of outer maxilliped small, not nearly half as large as merus
 *Pinnotheres strombi*
 Palpus of outer maxilliped large, nearly or quite half as large as merus
 *Pinnotheres maculatus*
88. Carapace with a ridge entirely across hinder part, behind which the
 surface slopes steeply down *Pinnixa chacei*
 Carapace without a ridge on back part or with a ridge on cardiac region
 only 89
89. Fourth leg when extended reaching end or beyond end of merus of
 third leg 90
 Fourth leg when extended not reaching end of merus of third leg
 *Pinnixa floridana*
90. Carapace less than twice as wide as long 91
 Carapace more than twice as wide as long 92
91. Propodus of third leg as wide as long or nearly so *Pinnixa cylindrica*
 Propodus of third leg distinctly longer than wide *Pinnixa retinens*
92. Single bilobed cardiac ridge present *Pinnixa pearsei*
 Two short ridges on cardiac region *Pinnixa chaetoptera*
93. Dorsal ridge oblique 94
 Dorsal ridge transverse *Dissodactylus stebbingi*
94. Dactyls of first three legs bifurcate half way to their base
 *Dissodactylus mellitae*
 Dactyls of first three legs bifurcate less than halfway to their base
 *Dissodactylus crinitichelis*
95. Chelipeds mobile, seldom much larger than the other legs.
 INACHIDAE 96
 Chelipeds not specially mobile, much larger than the other legs; carapace
 sharply triangular. PARTHENOPIDAE
96. Basal article of antenna extremely slender throughout its length; eyes
 without orbits and not concealed 97
 Basal article of antenna not slender, often very broad; eyes with orbits
 or capable of concealment 101
97. Carapace elongate, narrowed in front; external maxillipeds somewhat
 pediform, with the palp large and coarse, merus often narrower than
 ischium; basal article of antenna subcylindrical 98
 Carapace usually subtriangular; external maxillipeds with the merus as
 broad as the ischium and the palp small; basal article of antenna flattened
 or concave ventrally *Inachoides laevis*
98. Rostrum very long; dactyli of walking legs shorter than the propodites 99
 Rostrum short; dactyli of walking legs shorter than the propodites ... 100
99. Carapace smooth and even above; antennae concealed beneath the ros-
 trum; color, red, with black stripes *Stenorynchus seticornis*
 Carapace rough and uneven above; antenna long, flagella exposed
 *Metoporphaphis calcarata*

100. Dactyli of last three ambulatory legs curved, short, contained twice, or more than twice, in their respective propodites; cardiac prominence low; pterygostomian region protuberant, more or less compressed and prolonged in a tubercle at the middle; sternal segments of males separated by deep grooves *Podochela riisei*
 Dactyli of last three legs more than half as long as their respective propodites; cardiac prominence greater, spiniform; pterygostomian region with long, thin lamina produced downward; sternal segments of males flat, with sharp-edged margins *Podochela sidneyi*
101. Basal article of antenna of moderate width; orbits incomplete, never entirely concealing the cornea 102
 Basal article of antenna very broad; orbits always complete enough to conceal the retracted cornea from dorsal view; eyestalks usually long 106
102. Eyes with orbits, having a large, cupped postocular process into which the eye is retractile 103
 Eyes without true orbits; carapace oblong with two lateral lobes; rostrum slightly bilobed at tip *Epialtus dilatatus forma elongata*
103. Supraocular eave in close contact with the postocular process; spines and tubercles on the carapace 104
 Supraocular eave not in close contact with the postocular spine; small crab with smooth, evenly rounded carapace *Pelia mutica*
104. Median spines six, tubercles few 105
 Median spines of carapace nine; tubercles numerous, unevenly placed *Libinia emarginata*
105. Fork of rostrum in adult shallow, horns blunt; lateral marginal spines in young large *Libinia dubia*
 Fork of rostrum in young deeper, horns acute, curved toward each other. Lateral marginal spines small except for the posterior one, which is long and slender *Libinia erinacea*
106. Orbits projecting sideways beyond the general outline of the carapace and often tubular; legs not cristate 107
 Orbits not projecting sideways beyond the general outline of the carapace; cardiac prominence high, crenulate plates on legs *Hemus cristulipes*
107. Carapace not truncate anteriorly 108
 Carapace broadly truncate anteriorly; orbits facing forward; rostrum minute *Pitho anisodon*
108. Carapace ovate, as broad as long; orbits not tubular 109
 Rostrum large, usually with two strong horns 110
109. Carapace without smooth, oblique branchial sulci *Mithrax pleuracanthus*
 Carapace with smooth, oblique, branchial sulci *Mithrax forceps*
110. Orbits tubular, strongly projecting; basal antennal article very broad 111
 Orbits little projecting; basal antennal article moderately broad, armed with a prominent spine at anteroexternal angle *Microphrys bicornutus*
111. Rostral horns adjacent and subparallel at base. Four dorsal bosses, each with a sharp tubercle at tip 112

- Rostral horns divergent from base. Dorsal protuberances spiniform
 ----- *Macrocoeloma camptocerum*
112. Posterolateral projections narrow, spinelike.....*Macrocoeloma trispinosum*
 Posterolateral projections very broad, their margins continuous with marginal lines of carapace ----- *Macrocoeloma trispinosum nodipes*
113. Carapace not laterally expanded over the ambulatory legs
 ----- *Parthenope serrata*
 Carapace more or less expanded to form a vault in which the ambulatory legs are concealed ----- *Heterocypta granulata*

GLOSSARY OF TERMS USED IN THE KEY

- Ambulatory legs—legs used for walking rather than feeding (cheli-peds), swimming, or cleaning.
- Annuli—rings or joints.
- Antennae—styliform tactile organs placed laterad to the smaller antennules.
- Article—joint; often used synonymously with annulus.
- Branchial region—lateral area of the carapace extending from the hepatic region to the posterior border.
- Carapace—part of shell covering the cephalothorax.
- Cardiac region—median area of the carapace located behind the cervical suture and ahead of the intestinal (last) region.
- Carina—a keel-like prominence.
- Carpus—(wrist) fifth segment of leg or maxilliped.
- Chelae—forceps-like pinching claws, the last two segments of the cheliped.
- Crenulate—minutely scalloped.
- Dactyl—movable finger of chela or terminal segment of pereopod.
- Endopodite—inner or main branch of an appendage.
- Epistome—narrow structure between the mouth parts and the antennular bases.
- Flagellum—styliform terminal process of an antenna or antennule.
- Front—usuall, the anterior border of the carapace between the orbits; sometimes, the anterior margin between the anterolateral extremities.
- Gastric region—median area of the carapace between the cardiac and frontal regions.
- Hepatic region—small anterolateral region between the epibranchial and orbital regions.
- Interocular teeth—projections of the carapace between the eyes.
- Ischium—Third segment (from the body) of a leg or maxilliped.

- Maxillipeds—the three outermost pairs of masticatory organs.
- Merus—fourth segment (from the body) of a leg or maxilliped.
- Usually the first long segment of a cheliped.
- Orbital lobes or teeth—the first of the anterolateral teeth behind the orbits.
- Palp—last two or three joints following the merus joint of a maxilliped.
- Palate—roof of the mouth.
- Pediform—foot-shaped.
- Pereiopods—the chelipeds and walking legs.
- Pilose—covered with soft hair.
- Pleopods—appendages on the underside of the abdomen.
- Pleura—lateral plates of the abdominal segments of a shrimp.
- Postocular process—equivalent to the orbital tooth or postorbital spine.
- Propodus—sixth segment of a leg or maxilliped. In a cheliped, the palmar portion or manus and the immovable finger.
- Pterygostomian region—triangular space on the ventral surface of the carapace, on either side of the buccal cavity.
- Rostrum—forward projection of the carapace between the bases of the eyestalks.
- Sterna—plates on the ventral surface of the thorax.
- Styliform—developed into a slender process.
- Subchelate—imperfectly chelate, the terminal segment folding back against the next one.
- Subcylindrical—approaches a cylindrical form.
- Sulci—furrows or grooves.
- Tail fan—posterior appendages of the abdomen usually used in swimming backward; found in most *Macrura* and *Anomura*.
- Telson—central appendage of the tail fan.
- Truncate—the end cut off even; not tapering.
- Uropods—appendages of the tail fan flanking the telson.

ANNOTATED LIST OF SPECIES

Suborder NATANTIA

Tribe PENAEIDEA

Family PENAEIDAE

Penaeus setiferus (Linnaeus). (3, 8).³ The white shrimp is the most important commercial species of the Apalachicola fishery (Idyll, 1950). It is often taken in abundance in Mud Cove, on the outer beach of Alligator Point. None were taken in Alligator Harbor during this study.

Penaeus duorarum Burkenroad. Grooved shrimp are less abundant along the Gulf Beach of Alligator Point, although juveniles are often abundant in the bay. Approximately 100 of medium size were taken by a single pull of a 30-foot minnow seine near the laboratory pier on July 6, 1952. Larger individuals were found during winter months. The closely related *P. aztecus*, abundant off Louisiana, is said to occur in commercial catches at Apalachicola in the summer (Idyll, 1950).

Trachypeneus constrictus (Stimpson). This is a smaller species than the commercial shrimps. Two females, 59 and 66 mm in length, were taken 2 miles off Cape St. George Light on February 28, 1951. A 23 mm specimen was taken in Alligator Harbor, November 1, 1952.

Xiphopeneus kroyeri (Heller). (3, 32). Miles (1951) reported a catch of over 700 pounds of "sea bobs" in one trawl haul near Apalachicola, May 25, 1951. Because this species is small, shrimp fishermen usually avoid them if possible as there is no market in Florida at present. Burkenroad (1934) observed that *X. kroyeri* seldom enters inside waters of Louisiana, probably because of low salinity. None were found in Alligator Harbor during this study, although H. J. Humm observed a school under the laboratory pier in September, 1951. Four specimens collected by Miles ranged from 115 to 132 mm.

Sicyonia laevigata Stimpson. (8, 17). Hardbacks or coral shrimp (common names for the genus) prefer firm or irregular bottom and do not occur in schools. One specimen was taken in a dredge haul in the boat canal near St. Marks Light on a soft mud bottom.

³ Numbers refer to titles in the literature cited which contain figures or photographs of the species discussed.

Sicyonia brevirostris Stimpson, (8, 17). A single specimen was taken by trawl about 2 miles off Cape St. George Light on February 28, 1951, by Robley Miles. The length was 70 mm.

Sicyonia typica Boeck. (17, 32). A common species formerly known as *edwardsi*. A specimen taken near Carrabelle, February 18, 1950, was determined by Martin Burkenroad of the Texas Institute of Marine Science. Others have been taken along the break-water at St. Marks Light, in Alligator Harbor, and in the Gulf off Alligator Point. Length of the largest specimen was 49 mm. Distinctive longitudinal patches of bright blue color occur on the outer uropods.

Family SERGESTIDAE

Lucifer faxoni Borradaile. (8). This holoplanktonic decapod occurs sparingly in Alligator Harbor and more abundantly in the Gulf proper. A 10-minute tow with a No. 10 plankton net near buoy 26 off Alligator Point produced 137 specimens ranging from 2 to 11.2 mm in length.

Tribe CARIDEA

Family CRANGONIDAE

Alpheus heterochaelis Say. (8, 32). This large snapping shrimp or pistol shrimp inhabits quiet, shallow water, especially oyster bars. Its loud snapping is often heard at low tide along Drum Creek. A pistol claw from one of these shrimps was found in the stomach of a grouper caught in 6 fathoms of water by H. J. Humm.

Alpheus normanni Kingsley. (8). Often found among colonies of the ascidian, *Styela plicata*, this is probably the most common of the snapping shrimps in Alligator Harbor. A few were also found near buoy 26.

Synalpheus minus (Say). (7, 8). Common in sponges in deeper water, especially near buoy 26. Two specimens, however, were found in an ascidian cluster in Alligator Harbor. Adults usually occur in pairs. The species is easily recognized by the red color of the distal third of the snapping claw. The body is yellow to yellow-green.

Synalpheus fritzmulleri Coutiere. (7). Twelve of these colorful shrimps were taken from a tube sponge, *Callyspongia vaginalis*, at

the edge of South Shoals, about 8 miles SE of Alligator Point, on March 12, 1953. The color in life has been well described by Schmitt (1930).

Synalpheus townsendi Coutiere. (7, 8). The most frequently taken snapping shrimp in the buoy 26 area. This species seems less dependent on sponges than the other members of the genus taken locally.

Synalpheus pectiniger Coutiere. (7). Smallest species of the genus recorded here, it was collected only once, when 13 specimens were taken from a large yellow sponge secured by trawl about 2 miles off the mouth of the Ochlockonee river on March 14, 1953. This shrimp was found only in channels near the periphery of the sponge and usually in pairs. *S. longicarpus* occurred throughout the sponge but never close to *S. pectiniger*.

Synalpheus longicarpus (Herrick). (7, 8). Although the most abundant snapping shrimp at Beaufort, N. C. (Hay and Shore, 1918), this species seems to be restricted to loggerhead sponges and a similar, yellow sponge in this area. Coutiere (1909) emphasized the variations of many species of this genus. A specimen taken four miles ESE of St. Marks Light lacked both a rostrum and projections of the orbital lobes. A total of 893 specimens, most of them small, were taken from the same sponge mentioned in the discussion of *S. pectiniger*. The sponge was about 700 cubic inches in volume. Only 10 of these specimens were ovigerous, possibly resulting from overcrowding of the habitat as suggested by Coutiere (1909) to explain a similar observation.

Family HIPPOLYTIDAE

Angasia carolinensis (Kingsley). (8, 32). The grass shrimp is found in beds of turtle grass, *Thalassia testudinum*, where it is often abundant. Ovigerous specimens were 28 to 42 mm long. This shrimp is usually green in color, occasionally brown, with the young translucent.

Hippolyasmata wurdemanni (Gibbes). (8). The scarlet stripes of this shrimp provide an easy means of identification. It is usually encountered in clumps of algae, sponges, or ascidians and is widely distributed locally. The largest found was an ovigerous female 38 mm in length, which was taken January 7, 1950.

Hippolyte pleuracantha (Stimpson). (8). Ovigerous specimens of this tiny, translucent species ranged from 9.2 to 11.6 mm. It is abundant in shallow water among algae and eel grass.

Thor floridanus Kingsley. (14). Nine ovigerous specimens were found on a large plant of *Sargassum linifolium* growing on a rocky spot in ten feet of water, four miles ESE of St. Marks Light, August 17, 1952. Spawning had apparently just begun when 80 specimens, only three ovigerous, were taken from the same area, March 8, 1953. This shrimp has a very short rostrum and is almost as stocky as *Latreutes parvulus*; ovigerous specimens were 11 to 13.2 mm in length.

Latreutes parvulus (Stimpson). (8, 32). Twelve specimens of this shrimp were taken in the vicinity of Dog Island and near buoy 26; all were ovigerous and varied in length from 8.4 to 12.8 mm. They are usually associated with *Sargassum*, with which their mottled brown color blends. Fenner A. Chace, Jr., of the U. S. National Museum made the identification and provided the correct name for this species, which was formerly known as *Concordia gibberosus*.

Latreutes fucorum (Fabricius). (8, 32). *Sargassum* weed is also favored by this shrimp. Ovigerous specimens taken off the mouth of Ochlockonee Bay, March 14, 1953, were from 12.2 to 18.5 mm long. A single specimen was found in Alligator Harbor. The rostrums of those examined varied greatly as to length, depth, and number of spines.

Family PALAEMONIDAE

Periclimenes americanus (Kingsley). (9). This species is widely distributed in the area studied although it was never taken at the same time as the more numerous *P. longicaudatus*. Those from ESE of St. Marks Light were associated with *Sargassum*. Ovigerous females were taken from early March through August. The chelipeds have two dark bars at the bases of the dactyls and are unusually long, 12 mm on a specimen 14 mm long.

Periclimenes longicaudatus (Stimpson). (9). The translucence and small size of this shrimp cause it to be easily overlooked. It was not taken near St. Marks Light or buoy 26. Ovigerous females were taken in March and September.

Periclimenaeus wilsoni (Hay). (9). Pairs of this snapping shrimp occupy the canals of sponges. The major propodus is larger than

in any shrimps of the genus *Synalpheus* examined by the writer. For two pairs taken July 7, 1952, the ratio of the length of the propodus to that of the body was about one to four in the females and about two to three in the males. It has been reported previously only from Beaufort, N. C., and Tortugas, Florida (Holthuis, 1951).

Typton tortugae McClendon. (9). Two of these active little shrimps were found near the periphery of the same yellow sponge from which 893 *Synalpheus longicarpus* were taken. The hands are more nearly equal in size than in any other snapping shrimps so far found in this area. The chelae and dorsal part of the body are faintly orange in color and sprinkled with red spots. The movable finger of the chela and the tip of the fixed finger have dark borders. This species has not been reported previously north of Tortugas in the Gulf of Mexico.

Palaemon floridanus Chace. (10). This comparatively large member of the family was described (Chace, 1942) from specimens taken at Captiva Island, Florida. A number of these shrimps were observed hovering around a piling in the boat harbor near St. Marks Light, August 22, 1952; of 18 captured, 9 were ovigerous. Three specimens, two ovigerous, were taken in Alligator Harbor, April 28, 1950. One ovigerous specimen was 45 mm long.

Palaemonetes intermedius Holthuis. (10). Three specimens, 19 to 22 mm long, were taken in Alligator Harbor, January 14, 1950. They are much smaller than local specimens of the closely related *P. pugio*.

Palaemonetes pugio Holthuis. (10). This glass shrimp is abundant locally in brackish water. Forty specimens were seined from "tidal channels south of East River on the St. Marks Light road, 6.2 miles SSE of Newport" by R. W. Yerger and students, May 18, 1952. Two specimens, one ovigerous, were taken from drifting seaweed (*Gracilaria*) at the east end of the Apalachicola bridge, north side, February 18, 1953, by H. J. Humm. It is abundant in a landlocked, brackish pond near the Alligator Harbor Laboratory. A single specimen was taken in Alligator Harbor, April 4, 1953.

Family PORCELLANIDAE

Porcellana sayana (Leach). (32). A total of 28 were taken in dredge hauls near buoy 26 between October 18 and December 21,

1952; none was ovigerous. The largest was a male 12 mm long. George Grice collected 7 specimens near the mouth of the Ochlockonee River on October 31, 1954. Six of these, including a male 14 mm long, show the typical spotted coloration, but a single ovigerous female is cream-colored.

Porcellana soriata Say. (8). These warty little crabs are usually found in the interstices of sponges. Of 7 females taken from sponges of the genus *Ircinia* near buoy 26, July 7, 1952, 6 were ovigerous.

Petrolisthes armatus (Gibbes). This widely ranging anomuran crab is common in the Alligator Harbor area wherever it can find a hiding place in shallow water, especially on oyster bars. Although the species is common at Bermuda, it is not known from the east coast of the United States, except for a questionable record from Connecticut (Rathbun, 1905).

Petrolisthes galathinus (Bosc.). (8). The two species of *Petrolisthes* apparently do not overlap in habitat in local waters. *P. galathinus* is found in deeper water where it is one of the most abundant decapods. Thirty specimens taken 8 miles south of Alligator Point on November 18, 1952, ranged from 2 to 10.6 mm in length; the largest was an ovigerous female. None of the 54 specimens taken March 12, 1953, was carrying eggs.

Polyonyx macrocheles (Gibbes). (8). A pair of crabs of this species or of *Pinnixa chaetoptera* are usually to be found in the tube of the annelid, *Chaetopterus variopedatus*, although the two species of crabs are not known to occur together. Ovigerous specimens were found in November, 1953.

Euceramus praelongus Stimpson. (8). Specimens were taken near Dog Island and off Alligator Point. The largest specimen, 16 mm in length, was found under a shell on a beach west of Apalachicola, January 11, 1953, by Sue Barnett.

Family CALLIANASSIDAE

Callianassa islagrande Schmitt. (31). Although very abundant in a narrow band of the lower intertidal zone of Gulf sand beaches, this burrowing shrimp was not described until 1935 (a) by Waldo Schmitt from specimens collected at Grande Isle, Louisiana. A square meter dug to a depth of about 20 inches in the Gulf beach of Alligator Point produced 30 females (two ovigerous) and 3 males.

Mature individuals of both sexes from Alligator Point beach averaged 57 mm in length and somewhat longer from Dog Island where 3 males ranged from 75 to 78 mm. The species does not occur where the wave action is too slight, as in Alligator Harbor, or too strong, as at Cape San Blas.

Callianassa jamaicence louisianensis Schmitt. (31). This subspecies, abundant in sheltered bays and estuaries locally, was described at the same time as *C. islagrande* (Schmitt, 1935a). The mud-lined burrows are often over 3 feet in depth, hence specimens are not easily obtained. The method used by Lunz (1937b) in capturing *C. major* has not succeeded with either of the local species. Ovigerous females were taken near the Alligator Harbor Laboratory pier on September 10 and October 4, 1954. Body length of a female was 60 mm; of a male, 63 mm. Several red-patterned commensal copepods were usually found on this mud shrimp.

Upogebia affinis (Say). (8). This mud shrimp burrows in softer bottom than *Callianassa* does, especially where the narrow-leaved eel grass, *Halodule wrightii*, stabilizes the muddy substratum. It was taken along the rock breakwater near St. Marks Light, at Bald Point, and on the flats off the end of Alligator Point. A. S. Pearse (1952) described a parasitic isopod, *Phylloporus robustus*, from a specimen collected by H. J. Humm at the mouth of Alligator Harbor, June 19, 1952.

Family PAGURIDAE

Clibanarius vittatus (Bosc.). (8). The striped hermit crab is common along sheltered shores and is the largest species of Paguridae found in Alligator Harbor. It is frequently taken in shells of *Melongenella corona*, less often in *Busycon* and *Fasciolaria*. Many were found out of water at low tide.

Paguristes hummi, sp. nov.

Type: Male, holotype; Cat. No. 95,596, United States National Museum; from Alligator Harbor, Franklin County, Florida; June 1, 1952; collected by A. S. Pearse. *Paratypes:* 1 male in a sponge, April 17, 1952, and 2 males occupying a single sponge, May 10, 1952, from Alligator Harbor, collected by H. J. Humm; 1 male from a *Murex* shell, Alligator Harbor, April 4, 1953; 4 males, 1 female, from Mullet Key breakwater tidepool, Tampa Bay, Florida, October 10, 1953; 20 females (10 ovigerous), 25 males from the last locality, October 16, 1954. All type material is deposited in the U. S. National Museum.

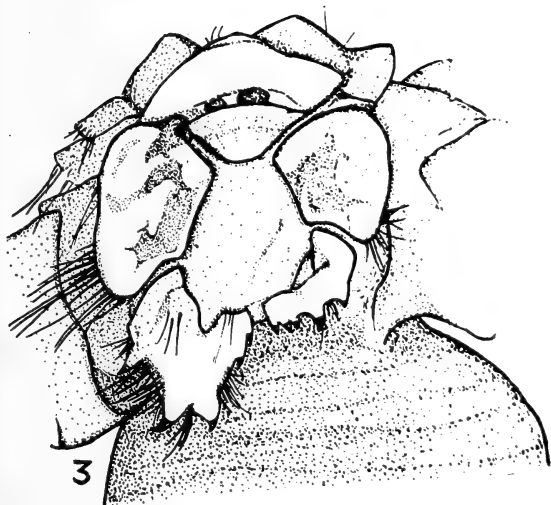
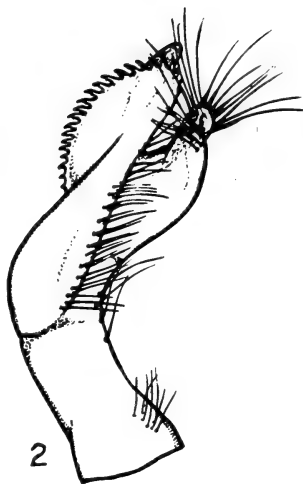
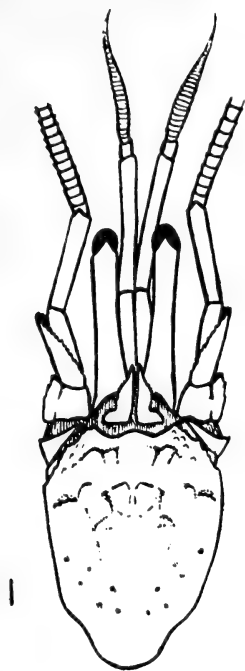

EXPLANATION OF FIGURES

1. Anterior portion of carapace and head appendages of *Paguristes hummi*. X 10.
2. First pleopod of *P. hummi*. X 55.
3. Ventral view of telson of *P. hummi*. X 20.
4. Second pleopod of *P. hummi*. X 55. (All figures are of holotype.)

Description: Anterior portion of carapace slightly longer than wide; rostral tooth obtuse, shorter than laterals, not reaching to base of eye scales; laterals short, armed with minute, marginal spinules; surface with a few setose tubercles, transverse depression in postfrontal region.

Eye-stalks, including the cornea, long, slightly exceeding the peduncles of the antennae; constricted in mid-section. Eye-scales medially adjacent from base to apex, except for shallow indentations near the bases; base sub-quadrate, lateral projections produced anterolaterally; apical regions armed with 4-7 spines anteriorly, the largest at the tip.

Antennal acicle extends $3/4$ length of eye-stalk; 5 spines on the inner margin, none on the outer. Third segment of peduncle of antennule reaches past cornea by half its length. Flagellum of antennule bears single rows of dense cilia on ventral surface, while that of the antenna has two rows forming a 120 angle ventrally, the rows consisting of a pair of long cilia at each articulation.

Chelipeds equal, similar, moderately spined, sparsely setose; merus crested dorsally with spinules and setae, single short spine on inner distal margin, inner surface smooth, outer surface and lower margin granular; carpus armed with 6-8 spines on inner margin of upper surface and 9 or more on the outer margin, with the spines increasing in length and number distally; the surface between the margins bears fewer spines and setae; lateral and ventral areas between the upper third of the inner surface and the outer margin are smooth. Manus twice as long as wide; armed with 4 longitudinal rows of spines on the upper surface, 6 spines in the inner row, only 4 that are distinct in the 2nd row, 5 in the 3rd row (all topped by a single bristle), 15 or more in the outer, marginal row, with the pollex bearing the largest spines; the bases of the outer row are setiferous. The prehensile edge of the pollex has 4 small teeth and many calcareous denticules; the 1st and largest tooth is $1/3$ the distance from the angle to the apex. The outer edge of the dactyl has 9 or more protuberances, only the first 3 of which are spinulose. The fingers gape slightly for $3/4$ of the distance to the corneous apices.

Ambulatory legs slender, propodi $3/4$ as long as dactyli, 1st pair crested with spinules on merus and propodus, 2nd pair with tubercles only; both pairs setose except for lateral surfaces of meri and inner surfaces of propodi.

Telson asymmetrical, bifid, and armed with a variable number of spines; on each lobe the two apical spines are the largest.

Color: In life, the outstanding color mark is an iridescent blue patch on the inner surface of the merus of the cheliped; this area is bordered anteriorly by a narrow black line, followed by a similar yellow line. In alcohol, the blue and yellow fade and the black line becomes brick red; the ambulatory legs have pinkish bands and the chelae are marked with blotches of similar coloring.

Measurements: Male holotype; length from rostrum to telson 22 mm, of anterior portion of carapace 4 mm, width 3.5 mm, length of cheliped 12 mm, of merus 4.5 mm, of carpus 2.7 mm, of manus 5.5 mm, of dactyl 3 mm; width of manus 2.7 mm, length of eyestalk 3.2 mm, of antennal acicle 2.5 mm.

Range: In Alligator Harbor this hermit is uncommon. At Mullet Key, in Tampa Bay, it was plentiful at times during the summer of 1953. It was not

observed at Mullet Key in 1954 until October 16, when several hundred were found in small tidal pools behind the breakwater after the season's first cold front had passed.

Habitat: Small sponges were the usual habitation in Alligator Harbor, although two specimens were taken in *Murex* shells. At Mullet Key it has been found only on the south side of the island, in the intertidal zone. The crabs averaged smaller here and were found in a variety of small gastropod shells, most commonly in those of the genus *Terebra*. Several were found in *Olivella* shells and one was taken in a scaphopod shell.

*Remarks:*⁴ This proposed species bears a closer resemblance to several species of the genus *Paguristes* found along the coasts of western and southern Africa, than it does to most of the American species. Of the 15 African species figured by Forest (1954), it resembles *P. hispidus* Edwards and Bouvier and *P. microphthalmus* Forest in the rudimentary development of the rostrum and in having the eye scales closely adjacent and similar in outline although differing in the number and position of the spines. *P. hummi* differs from all African species in the absence of spinules on the outer margins of the antennal acicles. The second pair of male pleopods most closely resemble those of *P. fagei* Forest (1954), although the two species are otherwise dissimilar. Of the American species, it is most like *P. praedator* Glassell (1937), from the Gulf of California, but differs in having larger spinules on the eye scales, 5 spinules instead of 2 or 3 on the inner side of the antennal acicle, and more spines on the chelipeds.

This proposed species is named for Dr. Harold J. Humm, of Duke University, who collected the first specimen and contributed it to the U. S. National Museum.

Isocheles wurdemanni Stimpson. One specimen, a male, was found occupying an *Oliva* shell on the outer beach of Alligator Point. It was the only hermit crab found in a shell of that genus in the area. The species does not seem to be abundant anywhere, although Dr. Fenner A. Chace, Jr., reports (*in litt.*) that there are specimens from Louisiana, Texas, and Venezuela in the U. S. National Museum. It resembles young of *Petrochirus bahamensis* but is white in color.

Petrochirus bahamensis (Herbst). (8). This large red hermit is rare in the Alligator Harbor area. A specimen with carapace

⁴ Reference has been made to the following papers since the original manuscript was prepared.

FOREST, JACQUES

1954. Les Paguristes des cotes occidentales et meridionales d'Afrique. Ann. S. Afr. Mus. 41(part 4): 159-213.

GLASSELL, S. A.

1937. The Templeton Crocker Expedition. XI. Hermit crabs from the Gulf of California and the west coast of Lower California. Zoologica, N. Y. Zool. Soc. 22(part 3): 241-263.

length 26 mm was dredged near buoy 26, March 12, 1953. It occupied a Scotch bonnet shell, *Phalium granulatum*, which bore on the outside six anemones, *Calliactus tricolor*. A larger specimen, carapace length 47 mm, was taken near the mouth of the Ochlockonee River by George Grice, October 31, 1954. It was occupying a *Busycon* shell.

Pagurus floridanus (Benedict). The flat-clawed hermit is characteristic of bays and inshore waters, although usually in somewhat deeper water than *P. longicarpus*. *Polynices duplicata*, the shark-eye shell, seems to be its favorite abode; its claws fit the snail shell like an operculum when it retracts. A sea anemone, *Calliactus tricolor*, is often present on the outside of the shell. There is some doubt that *P. floridanus* is specifically distinct from *P. pollicaris*, the closely-related Atlantic coast species (Chace, 1953, *in litt.*).

Pagurus longicarpus Say. (8). This plain little hermit is probably the most abundant pagurid in Alligator Harbor. It generally occupies gastropod shells smaller than those which shelter *P. floridanus*. An ovigerous female was taken from a *Nassarius* shell on September 8, 1952, in Alligator Harbor.

Pagurus annulipes (Stimpson). (8). Adults of this small hermit are often overlooked or taken to be juveniles of larger species. Though widely distributed locally, it seemed to be most abundant in the extensive grass beds off St. Marks Light. It occupies a variety of small snail shells and one was found in a tooth shell, another in a sponge. Five of 67 specimens taken March 7, 1953, off St. Marks Light were ovigerous. Carapace length of the largest was 6.8 mm.

Pagurus impressus (Benedict). The dimpled hermit is frequently taken by trawl or dredge on South Shoals between Mud Cove and buoy 26. Three specimens from near buoy 26 occupied these interesting abodes: (1) a tough, green sponge; (2) a shell of *Melongenacoma corona*, a gastropod found only in estuaries and bays; (3) a shell of *Murex brevifrons*, a gastropod not yet known alive locally.

Family ALBUNEIDAE

Lepidopa benedicti Schmitt. This beach burrower that roughly resembles the well-known mole crab, *Emerita*, was taken in the same habitat as *Callianassa islagrande*. As many as four were taken

in a square meter area though they seemed to be less abundant than this ordinarily. Another quadrat 4 by 20 feet yielded only 8 specimens, two of which were ovigerous, with lengths of 14.3 and 20 mm. It seemed to be more plentiful at Cape San Blas, west of Apalachicola, where the wave action is stronger than at Alligator Point.

Family HIPPIDAE

Emerita talpoida (Say). (32). Along the Gulf beach of Alligator Point the mole crab is gregarious but seldom abundant. On September 26, 1952, 158 were taken from an area of approximately two square meters. Of a total of 261 taken from September 26 to October 17, 1952, 221 were ovigerous with lengths from 18-32 mm. Modes occurred at 23-24 mm and 27-28 mm. They were scarce after October.

Tribe BRACHYURA

Family RANINIDAE

Ranilia muricata H. Milne Edwards. (8, 28). A portion of a carapace of this species was found on the outer beach of Dog Island in January, 1953. Since the identity was clear and the species known from the Anclote area (taken by the *Fish Hawk* in five fathoms in 1901), the species is included. Hay and Shore (1918) state that “. . . it appears to be confined to sand bottoms well offshore.”

Family DROMIIDAE

Dromidia antillensis Stimpson. (8, 28). This hirsute crab typically carries a sponge or ascidian large enough to cover its carapace. One specimen from off Alligator Point carried the ascidian, *Eudistoma capsulatum* (kindly determined by Dr. W. G. Van Name). Carapace color is usually dark red, but in a “soft shell” from near buoy 26 it was bright orange.

Hypoconcha arcuata Stimpson. (8, 28). Three specimens have been secured: one near Carabelle on February 18, 1950; another near buoy 26 at a depth of forty feet, July 28, 1953; and a third on the flats off the end of Alligator Point on October 24, 1953, by Miss Phyllis Carter. This “pelecypod hermit” lives in the concave side of a clam shell valve which it grasps “so tightly that it is almost impossible to remove the live animal from its abode without crushing it” (Hay and Shore, 1918).

Family CALAPPIDAE

Calappa flammea (Herbst). The flame-streaked box crab is found locally in deeper water offshore where it is often taken by shrimp trawlers. It was taken near buoy 26 and along South Shoals. The largest was an adult female 72 mm long and 107 mm wide. *Calappa* may spend much of its time partially buried in the sand (Pearse, Humm, and Wharton, 1942).

Hepatus epheliticus (Linnaeus). (8, 28). Though not taken in Alligator Harbor, liver crabs were often found along the outer beach where four males 37 to 43 mm wide were taken January 10, 1953. Carlgren and Hedgpeth (1952) present a figure of *Hepatus* carrying the anemone *Calliactis tricolor*. This commensal relationship was not observed locally, although a small *Hepatus* placed in an aquarium soon carried three anemones.

Family LEUCOSIIDAE

Persephona punctata aquilonaris Rathbun. (8, 28). The largest of the two purse crabs taken, this species was found only in Alligator Harbor. It is characterized by red blotches on the cream-colored carapace.

Persephona crinita Rathbun. (8, 28). Found in Alligator Harbor, where it is less common than the above species, off Alligator Point and in Apalachicola Bay, the latter record by Miles (1951). In this species the carapace is uniform blue-gray.

Family PORTUNIDAE

Ovalipes ocellatus guadulpensis (Saussure). (8, 26). Lady crabs frequent sandy shoals and none were found in Alligator Harbor. The numbers of shed carapaces on the beach indicated a greater abundance off Dog Island than off Alligator Point. An adult female from near buoy 26 was 68 mm wide. Eleven males were taken in one trawl haul eight miles south of Alligator Point, March 12, 1953.

Portunus gibbesi Stimpson. (8, 26). During winter months the catch of this species in trawl hauls exceeded that of all other portunids combined. Three trawl hauls in Mud Cove, January 10, 1953, yielded 92; 52 females, 38 males, and 2 juveniles. A large male, width 60 mm, was regenerating both chelipeds and one leg;

seven crab barnacles, *Chelonibia patula*, were attached to the carapace. *P. gibbesi* was more common near shore than at buoy 26.

Portunus spinimanus Latreille. (8, 26). Larger and narrower than *P. gibbesi*, *P. spinimanus* seems to be more generally distributed both with reference to depth and season. The largest female taken was 73 mm wide and 42 mm long. An ovigerous female was taken off Alligator Point, July 7, 1952.

Portunus depressifrons Stimpson. (8, 26). A single specimen was taken near buoy 26, November 29, 1952; length 25 mm, width 40 mm. The color pattern is somewhat similar to that of *P. spinimanus*, but the carapace is darker and more evenly mottled. Paddles and feet are light blue.

Callinectes sapidus Rathbun. (8, 26). The edible blue crab is abundant along the northern Gulf coast of Florida. Two spawning periods are evident in this region, one beginning in late February or early March and a second in late August or September. At these times, males and females tend to occupy separate areas (Miles, 1951). In Tampa Bay, females often swim at the surface, probably when migrating.

Barnacles of several species often occur on *C. sapidus*; *Balanus amphitrite* and *Chelonibia patula* attach to the carapace, *Octolasmis mulleri* parasitizes the gill chamber, and the sacculinid parasite, *Loxothylacus texanus*, lives beneath the abdomen. Humes (1941) found 640 specimens of *Octolasmis* in one gill chamber of *C. sapidus*.

Callinectes danae Smith. (26). Two small specimens were taken in Alligator Harbor and three along the outer beach. Miles (1951) reported this species quite common on the shrimp fishery grounds off Apalachicola. An ovigerous female taken by Miles is 67 mm wide.

Arenaeus cribrarius (Lamarck). (8, 26). Speckled sand crabs were common along the outer beach of Alligator Point. Between September 3 and October 17, 1952, 79 were taken in the wave line; eleven of these were adult females with widths from 79 to 96 mm, average 88 mm. None were ovigerous. The largest male seen was 110 mm wide. These crabs were taken at night with the aid of a light.

Family XANTHIDAE

Leptodius floridanus (Gibbes). (26). Two females, widths 18 and 22 mm, in the collection of the Florida State University Marine

Laboratory, were taken at Shell Point, Wakulla County, February 12, 1950. Rathbun gives no records for the United States north of the Florida keys and Tortugas.

Panopeus herbsti H. Milne Edwards. (8, 26). Found in two habitats in Alligator Harbor; on oyster bars and in the mud banks of Drum Creek. A male, 55 mm in width, was collected at the St. Marks Light breakwater on February 2, 1950, by Rollin Stevens. The dark body color, continued on legs and chelae, distinguishes *P. herbsti* from *Eurytium limosum*, which has propodi dark green above and tan below, with the fixed finger white, the movable finger lavender shading to tan.

Panopeus turgidus Rathbun. (26). A single specimen was taken at Wakulla Beach and determined by Dr. Fenner A. Chace, Jr. It apparently is more common further west along the Gulf coast.

Neopanope texana texana Stimpson. (26). Two other species, *N. packardi* and *Eurypanopeus depressus* are not easily distinguished from *N. texana*, all three of which are abundant in Alligator Harbor. *N. packardi* has a large basal tooth on the movable finger of the major chela. *E. depressus* adults are easily identified but the juveniles resemble species of *Neopanope* except for the more oval shape and flattened carapace. *Neopanope* spp. are most abundant in shallow water with soft bottom and ample vegetation (McRae, 1950).

Neopanope packardi (Kingsley). (26). Although this species seems to be more abundant locally than *N. texana*, it apparently is not known north of Miami on the Atlantic coast (Rathbun, 1930). The largest specimens were found during the cooler months.

Hexapanopeus angustifrons (Benedict and Rathbun). (8, 26). Occurs in Alligator Harbor but is more common in outside waters. On August 17, 1952, 27 specimens were taken from a piece of driftwood on the outer beach. Nine of these were males, 18 were females among which eight were ovigerous. Adults ranged from 8 to 12 mm in width. The variable russet, gray, and yellow color patterns are an aid in identification. There is often a yellow band along the anterior border of the carapace.

Eurypanopeus depressus (Smith). (8, 26). Although found in greatest abundance on oyster bars, *E. depressus* also occurs on barnacle-encrusted pilings and in clusters of the ascidian, *Styela plicata*. Nine ovigerous females collected in Alligator Harbor in

September averaged 9 mm in width while ten others (not ovigerous) taken in January ranged from 11 to 18 mm wide.

Eurytium limosum (Say). (8, 26). Probably no other locally occurring xanthid is more deserving of the name "mud crab." It is plentiful in the soft, muddy banks of Drum Creek. When this creek was treated with rotenone in July, 1952, many left their burrows to feed on dead minnows. The largest male taken was 34 mm wide; four ovigerous females taken in August ranged from 15 to 22 mm in width. This species resembles *Menippe mercenaria* but the habitats do not appear to overlap. A similar crab found in the same habitat was *Panopeus herbsti*, forma obesa.

Micropanope pusilla H. Milne Edwards. (26). Three specimens, including an ovigerous female, were taken near buoy 26 in July. This species was the smallest xanthid found.

Menippe mercenaria (Say). (8, 26). Juvenile stone crabs are abundant in local waters but large adults are uncommon. Young specimens are black or dark purple with white bands at the leg articulations. The dark color changes to dull red and finally to a grayish ground color with many deep purple spots. The young are widely distributed, taking refuge in natural holes and crevices, although McRae (1950) stated that *Menippe* shuns oyster bars and soft bottoms, and prefers turtle grass flats. Several large specimens were taken in the vicinity of rocky areas in 6 to 10 feet of water about five miles ESE of St. Marks Light in July, 1953.

Pilumnus sayi Rathbun. (8, 26). Locally the hairy mud crab is the most widely distributed of the xanthids and perhaps of all the decapods. It is uncommon in Alligator Harbor but at buoy 26 it is the most abundant species. Of 201 decapods (25 species) taken there December 8, 1952, 72 were *P. sayi*. Thirty of the 60 specimens taken along South Shoals in March, 1953 were adult females, 25 of which were ovigerous. They ranged from 12 to 31 mm in width, with an average of 17 mm. The largest male observed was 32 mm wide.

Pilumnus dasypodus Kingsley. (8, 26). Smaller, darker and less bristly than *P. sayi*, this species is also much less common in local waters. It was taken at St. Marks Light, Mud Cove, and near buoy 26. An ovigerous female taken in July, 1952 was 9.7 mm wide.

Lobopilumnus agassizi (Stimpson). (8, 26). A single specimen, a male 14 mm wide, was taken near buoy 26 in July, 1952 by H. J. Humm.

Family GONEPLACIDAE

Euryplax nitida Stimpson. (24). A male, width 26 mm, was found under a conch shell on the flats at the mouth of Alligator Harbor in November, 1952 by H. J. Humm. A 9 mm specimen was taken from the stomach of a blackfish (*Centropristes melanus*) caught near buoy 26, December 21, 1952.

Family PINNOTHERIDAE

Pinnotheres strombi Rathbun. (24). Miss Sylvia A. Earle found a single female while examining 137 specimens of *Strombus alatus* taken by trawl about three miles SSW of Alligator Point, June 17, 1953.

Pinnotheres maculatus Say. (8, 24). Mussel crabs were common in the scallop, *Pecten gibbus*, in Alligator Harbor during the summer of 1952 but were not found in scallops taken several miles SE of St. Marks Light at that time. Males were occasionally seen swimming at the surface. A female was found in the large clam, *Atrina rigida*. All females taken in July were ovigerous.

Dissodactylus mellitae Rathbun. (8, 24). Although commonly associated with the sand dollar, *Mellita quinquesperforata*, this species appears to be least specific with reference to host of any of the three species of the genus recorded from the area. All are characteristically found clinging to the underside of a sand dollar or sea biscuit. An examination of 50 *Mellita* from the outer beach on August 25, 1952, yielded 68 *D. mellitae*. Sand dollars in Alligator Harbor, however, had very few commensal crabs. Thirty-five from near the laboratory pier produced only one crab; 110 sand dollars from Drum Point had only seven crabs. At the harbor mouth sand bar, a collection of 50 *Mellita* yielded 182 *Dissodactylus* on 41 of the sand dollars. These crabs were 0.9 to 4.8 mm in width. Ovigerous females were noted in July.

Near buoy 26, a male was taken along with five *D. stebbingi* from the sea biscuit, *Clypeaster subdepressus*, on July 7, 1952. Eight were taken from the purple sand dollar, *Encope michelini*, on November 15, 1952, about eight miles south of Alligator Point. Ten *D. crinitichelis* were also present on these sand dollars.

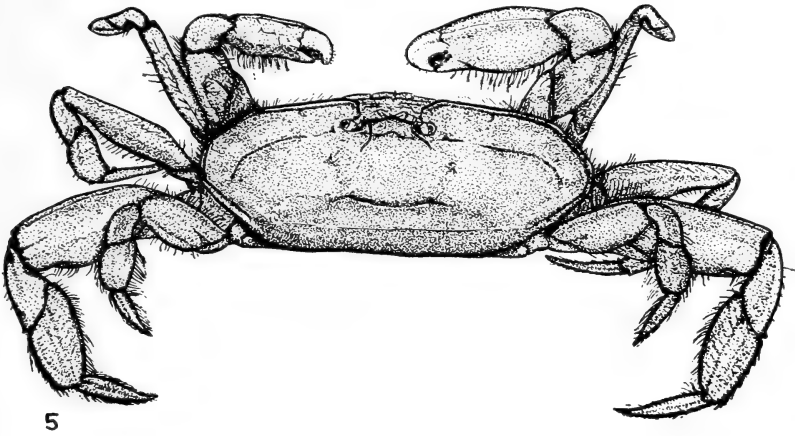

5

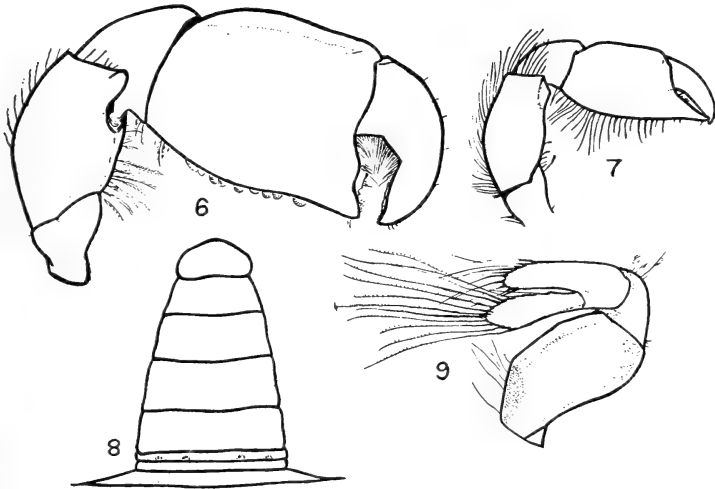

EXPLANATION OF FIGURES

5. Dorsal view of *Pinnixa chacei* holotype male. X 15.
 6. Right cheliped of *P. chacei* holotype male. X 30.
 7. Right cheliped of *P. chacei* allotype female. X 30.
 8. Abdomen of *P. chacei* holotype male. X 30.
 9. Left outer maxilliped of *P. chacei* holotype male. X 60.

Dissodactylus crinitichelis Moreira. (24). The ten specimens mentioned above were 2.4 to 10 mm wide; one female was ovigerous. This species attains a larger size than *D. mellitae* and varies from white to dark-patterned. Rathbun described this crab under the appropriate name, *D. encopei* in 1901, and was unaware of its previous description when she published her monograph on the grapsoid crabs in 1918. She listed it correctly in her 1933 report on the *Brachyura* of Porto Rico and the Virgin Islands.

Dissodactylus stebbingi Rathbun. (24). Five specimens were found on the underside of sea biscuits taken near buoy 26, July 7, 1952. The largest was an ovigerous female 4.2 mm wide. Sea biscuits taken at other times did not yield the commensal crab, although it is probable that the crabs are often washed off before the dredge or trawl is taken aboard.

Pinnixa chacei, sp. nov.

Types: Male holotype, Cat. No. 95,694, and ovigerous female allotype, from Gulf Beach of Alligator Point, Franklin County, Florida; collected on October 4, 1952. Paratypes: 5 other males taken at the same time; 6 females (1 ovigerous) from the same place, August 30, 1952; 14 specimens from Cat Island, Mississippi, including 2 adult and 6 juvenile males, 3 adult ovigerous females and 3 juveniles, collected by H. M. Hefley. All type material is deposited in the U. S. National Museum.

Description: Carapace broad, 2.5 times as wide as long. A high sharp carina extending across carapace in cardiac region, meeting posterior ends of lateral crests near posterolateral borders. Postfrontal crest reaching orbital margins laterally and interrupted medially by a shallow groove. Granulate anterolateral line extending transversely from orbits and curving to meet lateral crests between bases of 4th and 5th legs. Subhepatic margins continuous with lateral crests and prominent from lateral angles to epistome. Frontal region conspicuously recessed behind subhepatic margins; epistome plainly visible from above. Front trilobate, median point obtuse, extending as far as laterals; orbits ovoid, half as wide as front. Surface of carapace smooth, subhepatic regions pubescent. Antenna equal to front in length.

Chela large in male. Palm short, high, and thin, $3/5$ as thick as high, $5/6$ as high as long; dorsal margin ridged and straight; lower margin convex for first $3/5$ of distance, straight distally to tip; dense tuft of pubescence in gape. Chela otherwise smooth except for single row of fine hair extending upward from near lower edge on inner surface. Thumb short, prehensile edge truncate, bidentate; proximal tooth beginning at lower edge of gape, 4 times as high as wide and separated from distal tooth by a groove equal to the vertical height of the latter; both teeth set with minute denticles, a single denticle in the groove. Movable finger evenly curved on outer surface; prehensile

edge concave proximally, straight on distal half, with at least 9 denticles on the proximal 3/4.

Dactyls of walking legs slender, of 4th leg straight, of the others slightly curved, especially so on 2nd pair; dactyl of 4th leg slightly overreaching merus of 3rd. Merus and propodus of 3rd leg broad, merus more than twice as long as wide, propodus more than one and a half times; legs bare and smooth except for fine fringes of hair on the margins.

Abdomen widest at base, tapering uniformly, except for 6th segment which is somewhat constricted; segments subequal in length.

Variations: Chelae much smaller in female; fixed finger 2/3 length of movable finger; upper tooth absent; small indentation on lower edge of movable finger near base; no tuft of hairs in angle of gape but a continuous fringe on upper surface of movable finger. Abdomen of female fringed with hair. Chelae of juvenile males resemble those of females. Adults from Cat Island, Mississippi, have a short, dark pubescence in the fissures of the carapace and on the subhepatic regions, apparently due to adhering particles; the margins of the legs have the hair worn away.

Color: In life, males white, with brown specking; females slate grey, with translucent legs; juveniles paler. In alcohol, males white, females amber.

Measurements: Male holotype, length of carapace from rostral tip to posterior border 3.3 mm, width 8.2 mm; length of 3rd leg about 9.8 mm, of merus of 3rd leg along the outer margin 3.7 mm, width 1.7 mm, length of propodus 2.4 mm, width 1.5 mm. Female paratype, length 2.7 mm, width 6 mm.

Range: Known to occur from Alligator Harbor, Florida, to Grande Isle, Louisiana (specimens examined by Fenner A. Chace, Jr., and returned to collector).

Habitat: Intertidal zone; commensal with *Callinassa islagrande*, living in the upper part of the fragile sand-walled burrows.

Remarks: This proposed species is near *P. patagoniensis* Rathbun (1918), known only from San Matias Bay, eastern Patagonia. The most apparent difference is the recessed frontal region of *P. chacei*; in this species the margin of the front lies about half way between the frontal crest and the epistome, whereas in *P. patagoniensis* the frontal margin is almost directly above the epistome and in line with the subhepatic margins of the carapace. *P. chacei* also has the cardiac crest slightly irregular and concave in outline rather than even and convex, and the crest terminating laterally farther from the postero-lateral borders; the anterolateral line less prominent and less evenly curved laterally; the gastro-cardiac furrow deeper and straighter; the merus of the 3rd walking legs less dilated ventrally and entire, instead of armed with minute teeth and the propodal length-width ratio 2.2 rather than 1.8 as in *P. patagoniensis*; and the penultimate segment of the abdomen less narrowed distally.

The proposed species differs from *P. cristata* Rathbun (1918), from the coasts of the Carolinas, in the following respects: The carapace is less broad, the width-length ratio 2.5, compared with 2.85 in *P. cristata*; the lateral angles are less acutely produced, the frontal region more recessed; the anterolateral line begins at the orbits and curves to meet the border further back instead

of starting in the hepatic region and extending almost straight to the border; the post-frontal crest is more distinct; the antennae are shorter by half the length of an orbit; a narrower groove separates the proximal tooth from the distal tooth and the proximal tooth is broader; the movable finger is less evenly curved; and there is a pubescent tuft in the gape and a fringe of hair on the palm, whereas in *P. cristata* the chela is nearly bare. The 3rd walking leg is proportionately heavier, the length-width ratio of the merus and propodus being 2.2 and 1.6 respectively, rather than 2.9 and 1.8 as in *P. cristata*; the posterior margin of the 3rd leg is bare rather than densely pubescent. The penultimate segment of the abdomen is shorter and slightly less constricted than in *P. cristata*. Females of *P. cristata* have a rudimentary proximal tooth above the fixed finger, whereas this tooth is absent in *P. chacei*.

This species is named for Dr. Fenner A. Chace, Jr., Curator, Division of Marine Invertebrates, U. S. National Museum, who first recognized significant differences between this species and those previously known.

Pinnixa floridana Rathbun. (24). This is the only species of *Pinnixa* found here which was not obtained by digging, hence its commensal relationship is not known locally. A male was found under a rock in about ten feet of water four miles ESE of St. Marks Light, July 13, 1952. Three others, one male and two ovigerous females, were taken from a compound ascidian growing at the base of a soft coral, *Eugorgia virgulata*, which washed ashore on the outer beach of Alligator Point in August, 1952.

Pinnixa retinens Rathbun. (24). An ovigerous female was taken from the burrow of the mud shrimp, *Upogebia affinis*, on the bar at the mouth of Alligator Harbor in June, 1952. Dr. Fenner A. Chace, Jr., stated (*in litt.*) that this was only the second report of this crab since its discovery in Chesapeake Bay in 1918. He had received another specimen from Joel Hedgpeth, Texas Institute of Marine Science, a few weeks earlier.

Pinnixa chaetoptera Stimpson. (8, 24). This species is represented by two forms along the northern Gulf Coast. The larger form lives in the tubes of the annelid, *Chaetopterus variopedatus*, the smaller one in the burrow of *Callianassa jamaicensis louisianensis*. The latter form is probably the more common one, but it apparently has been overlooked previously (Chace, *in litt.*). The crab seems to prefer the upper narrow portion of the *Callianassa* burrow. Of 44 specimens taken September 19 and October 1, 1952, 20 were males ranging in width from 3.1 to 7.0 mm with a width/length ratio of 2.3/1; fourteen were adult females rang-

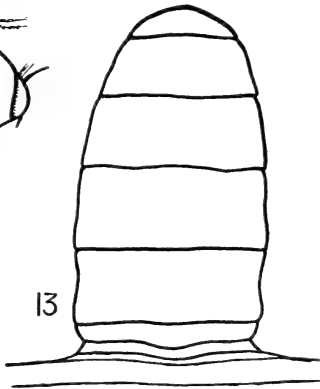
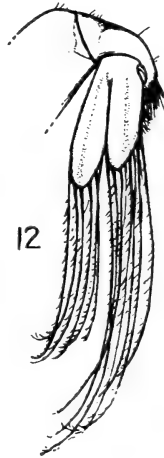
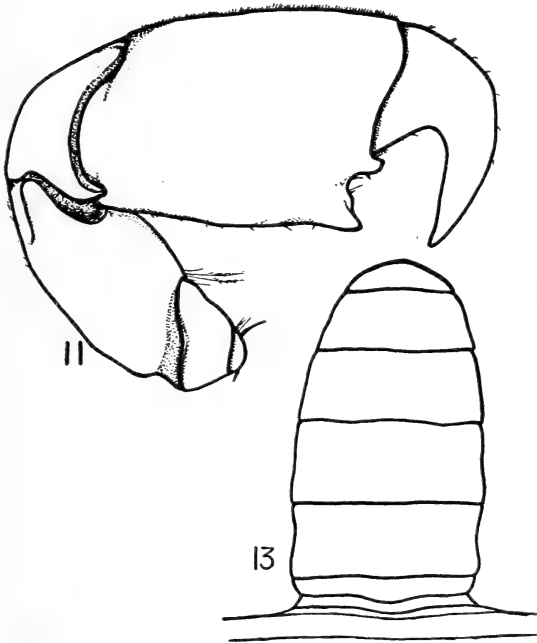
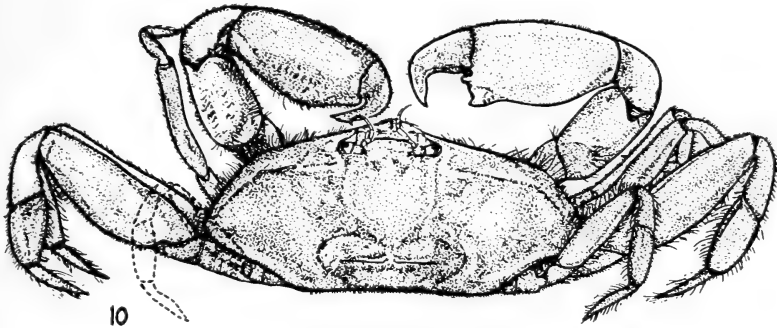

EXPLANATION OF FIGURES

10. Dorsal view of *Pinnixa pearsei* holotype male. X 10.
 11. Right cheliped of *P. pearsei* holotype male. X 30.
 12. Right outer maxilliped of *P. pearsei* holotype male. X 60.
 13. Abdomen of *P. pearsei* holotype male. X 30.

ing in width from 4.8 to 8.8 mm with a width/length ratio of 2.4/1. Ten of these females were ovigerous.

An ovigerous female of the larger form was taken from a *Chaetopterus* tube May 3, 1952; it was 13.6 mm wide.

Rathbun (1918) reported an ovigerous female from Rio de Janiero with a width of only 7 mm and with other slight differences from typical specimens. This suggests that the small form may be widely distributed.

Pinnixa pearsei, sp. nov.

Types: Male, holotype; Cat. No. 74959, from a sand-mud beach among *Diopatria* tubes, at Indian Pass, Apalachicola, Florida; November 30, 1935; collected by A. S. Pearse. Male, paratype; found in a worm tube at the mouth of Alligator Harbor, Franklin County, Florida; November 22, 1952; collected by H. J. Humm.

Description: Carapace broad, over twice as wide as long. Cardiac crest a straight line rising from branchio-cardiac fissures to an elevated, bilobed prominence medially. Anterolateral crest denticulate, extending from inner hepatic region to base of 3rd leg. Deep urogastric depression joined anteriorly by longitudinal fissures which bifurcate 3 times before passing the orbits laterally, the branch furrows are connected by a cervical groove; posteriorly, diagonal furrows delimit the cardiac carina. Wide depressions parallel the raised posterolateral border. Posteriorly, the carapace slopes abruptly from the cardiac crest. Surface punctate, lateral extremities pubescent, prominences worn bare; 2 rows of hair in pterygostomial region, the lower composed of dense, short hair, the upper of long, feather-like hair.

Chela massive, thickness and height respectively $\frac{3}{5}$ and $\frac{4}{5}$ the length; upper margin convex, lower straight; thumb bidentate; distal tooth truncate, tipped with sharp spine, the point of which is at right angles to the lower and distal margins of the palm; small peg-like tooth proximal to insertion of dactyl. Tip of dactyl meeting fixed tooth on inner angle. Entire surface of chela finely pubescent. Legs long and slender, except 3rd which is much more broad.

Abdomen broad, tapering uniformly to rounded distal segment.

Variations: The paratype male has a proportionately larger proximal tooth on the chela; the cardiac ridge is less raised and lacks the prominent lobes; there is less hair present; and the chelae are less swollen.

Color: In alcohol, the adult male is brown; the smaller male is nearly white.

Measurements: Male holotype, length of carapace 3.5 mm, width 8 mm; length of 3rd leg about 9.6 mm, of merus of 3rd leg along the outer margin 4 mm, width 2.3 mm, length of propodus 1.4 mm, width 0.8 mm. Male paratype, length of carapace 2.6 mm, width 5.7 mm.

Range: Known only from the types.

Habitat: Sand-mud areas in the intertidal zone; host unknown, probably an annelid worm.

Remarks: This proposed species is closely allied to *P. sayana* Stimpson, Rathbun (1918), which ranges from Massachusetts to Sarasota Bay, Florida. *P. pearsei* may be separated by these characters: The cardiac crest is higher, straight, and has peaks less than a fourth the distance from the midpoint to the end, whereas, in *P. sayana* the crest is advanced forward and is highest midway between the ends and the midpoint; the slope behind the cardiac crest is much steeper; the gastro-cardiac depression is greater; the carapace is broader, 2.3 and 2.2 times as long as wide in the type and paratype respectively, instead of 1.8 to 2.0 times as in *P. sayana*; and the propodus of the 3rd walking leg is broader, 1.7 and 1.5 times as long as wide respectively in the type and paratype, instead of 1.8 to 2.6 times as in *P. sayana*.

This species is named for Dr. A. S. Pearse, who collected the type specimen.

Pinnixa cylindrica Say. (8, 24). This species has been collected in the intertidal zone at a number of stations and seems to be associated with several of the larger annelids. It does not seem to have been studied since Stimpson stated in 1859 that "it lives with the lobworm (*Arenicola cristata*)" as quoted by Rathbun (1918).

Family GRAPSIDAE

Sesarma reticulatum (Say). (8, 24). The soft mud banks of Drum Creek have been the only source of specimens of this salt marsh crab, although it is probably widely distributed locally. It reaches a larger size than the more often seen *S. cinereum*.

Sesarma cinereum Say. (8, 24). The square-backed fiddler is abundant throughout the area on and above the drift line of sheltered beaches. Ovigerous females were observed in August.

Family OCYPODIDAE

Ocypode quadratus (Fabricius). (8, 24). The ghost crab is abundant above the intertidal zone along the outer beach of Alligator Point, but is not seen on the bay side. In a collection of 50, only two were adult males (24 and 27 mm wide), 14 were adult females (23 to 38 mm wide), and 34 were juveniles (9 to 17 mm wide). The 17 to 23 mm range in which no specimens fell probably separated juveniles of that summer from adults hatched the previous year. It is the opinion of H. J. Humm that this species attains a larger size in North Carolina than at Alligator Point.

Uca minax (Le Conte). (8, 24). The red-jointed fiddler was found only along a drainage ditch at Spring Creek, but it is probably common in other similar areas of fresh water drainage. The largest male collected was 23 mm wide.

Uca pugnax rapax (Smith). (24, 27). The mud fiddler was found along mud banks and in salt marshes. It seems to avoid open sandy areas. A large male was 21 mm wide.

Uca speciosa (Ives). (24). This is the smallest and apparently the least abundant of the four local species. It has been found along Drum Creek, Alligator Harbor, and at Wakulla Beach; areas with muddy substrata. An adult male was 11 mm wide.

Uca pugilator (Bosc). (8, 24). This abundant fiddler is seen in droves along sandy bay beaches during the warmer months of the year; during cool weather it remains inactive in burrows 6 to 12 inches deep.

Family MAJIDAE

Stenorynchus seticornis (Herbst). (8, 25, 27). Only two specimens of this widely distributed arrow crab were taken, both dredged near buoy 26. The contrasting red and white lines on the clean carapace make it easily recognized.

Metoporphaphis calcarata (Say). (8, 25). This "submarine daddy-long-legs" is common in Mud Cove but is not found at buoy 26. It is able to remain in suspension in the water by rhythmic waving of its long, setae-lined legs. It was not seen to carry foreign material on its rough, spiny, carapace. Oviparous females were observed in March and August.

Podocheila riisei Stimpson. (8, 25, 27). These long-legged spider crabs were most abundant around the rocky areas about four miles ESE of St. Marks Light. Ascidiarians are often found on the carapace and bryozoa are frequently attached to the legs. Those collected near or in growths of *Sargassum* were brown; specimens from near buoy 26 were brick red and bore species of red algae on the carapace, especially *Calathamnion byssoideum*, a filamentous species. The largest oviparous female examined, length 21 mm, was collected near Carabelle on February 18, 1950.

Podocheila sidneyi Rathbun. (8, 24). Four specimens were collected, three from near buoy 26 and one from near Carabelle. One male was 21 mm long. This species is easily separated from *P. riisei* by the flat sternal plates on the ventral side.

Inachoides laevis Stimpson. (25, 27). Adults of this species are easily mistaken for young of *Podochela*. Seven of nine taken near buoy 26, November 29, 1952, were ovigerous females 4.6 to 5.5 mm long. The largest male was 8.1 mm long. It was found only near buoy 26.

Epialtus dilatatus forma elongata Rathbun. (25). One of the many *Crustacea* which seek shelter in attached plants of *Sargassum* is this rather uncommon, guitar-shaped crab, the elongated form of which is known only from the west coast of Florida. An ovigerous female taken off Ochlockonee Bay, March 14, 1953, was 12 mm long. The largest male observed was 16 mm long.

Pelia mutica (Gibbes). (8, 25, 27). One of the most widely distributed of the spider crabs locally, *P. mutica* is also one of the smallest. In shallow water it is often found in clumps of the ascidian, *Styela*. Ovigerous females were taken in July and November and ranged from 4.8 to 9.5 mm long.

Libinia emarginata Leach. (8, 25). Immature specimens of this spider crab are common in local waters but adults have been taken infrequently. The largest was a male with a length of 102 mm and a width of 95 mm. Distance between the outstretched chelae was 38 cm.

Libinia dubia H. Milne Edwards. (8, 25). *L. dubia* seemed to be more common in Alligator Harbor than *L. emarginata*, but the reverse was true in outside waters. A large female, length 70 mm, taken in Alligator Harbor, June 11, 1952, weighed 153 grams, although this included 93 *Balanus eburneus* attached to the carapace. Adults of *dubia* and *emarginata* are readily distinguished when compared, but immature specimens are separated with difficulty. The rostrum of *L. dubia* is much longer, forming a V; the carapace is not so wide, and there is but one spine on the intestinal region (most posterior) whereas *L. emarginata* has two. Ovigerous specimens of *Libinia* were not observed.

Libinia erinacea (A. Milne Edwards). (25). Adults of this species have never been found, and Rathbun (1925) has predicted that they may prove to be only a variety of *L. dubia* when found. Small specimens have been collected locally in Alligator Harbor and near Carabelle. The two largest were determined by Dr. Fenner A. Chace, Jr., U. S. National Museum.

Hemus cristulipes A. Milne Edwards. (25, 27). Six of these odd little crabs were taken near buoy 26 in November and December, 1952. The crenulate plates on the legs and the pyramidal carapace distinguish it from *Pelia mutica*. A female was 5.3 mm long.

Pitho anisodon (von Martens). (25). Small specimens of *Pitho* were taken at rocky places SE of St. Marks Light and near St. Teresa. The only adult found was a male, width 30 mm, length 25 mm. The carapace is usually covered by a growth of sessile animals and plants.

Mithrax pleuracanthus Stimpson. (25). Juveniles were frequently taken near buoy 26 although adults seemed rare. The largest was a male 28 mm wide and 24 mm long.

Mithrax forceps (A. Milne Edwards). (8, 25). A female 13 mm long and 11 mm wide was taken from the stomach of a blackfish, *Centropristes melanus*, caught near buoy 26. Two small males were found by Richard Durant on some material brought up with the anchor near buoy 26. This crab is much flattened and probably lives in rock crevices. Its color is brick red.

Macrocoeloma trispinosum trispinosum (Latreille). (8, 25). Largest specimen taken was a male 20 mm long. Sponge crabs increase in number as buoy 26 is approached. Offshore specimens are red or maroon in color while those from shallow water are brown or olive. Larger specimens usually carry a considerable growth of sponge.

Macrocoeloma trispinosum nodipes (Desbonne). (8, 25). A male 27 mm long and 23 mm wide was taken near buoy 26. The clean carapace and bright orange color indicated that it had recently shed.

Macrocoeloma camptocerum (Stimpson). (8, 25). The single specimen of this species was taken in Alligator Harbor, May 19, 1951, and sent to Dr. Fenner A Chace, Jr., who made the determination.

Microphrys bicornutus (Latreille). (8, 25, 27). H. J. Humm collected the only specimen, a female, near buoy 26. The carapace was 9 mm long and covered by foreign material.

Family PARTHENOPIDAE

Heterocrypta granulata (Gibbes). (8, 25). The triangle crab is adapted to living on shell bottoms. The largest specimen, 14 mm wide, was taken in Alligator Harbor.

List of Species Known or Expected to Occur Off the Coast of Northwestern Florida within the Thirty Fathom Line But Not Found During This Study.

Species	Area	Latitude	Longitude	Depth
PENAEIDAE				
<i>Penaeus aztecus</i> Ives	Pensacola			
<i>Sicyonia dorsalis</i> Kingsley	Off Louisiana			
<i>Trachypeneus similis</i> (Smith)	Pensacola Bay			
SERGESTIDAE				
<i>Acetes caroliniae</i> Hansen	Louisiana coast			
GRANCONIDAE				
<i>Crangon armillatus</i> (H. Milne Edwards)	Grande Isle, La.	29 15 30	85 29 30	21 fath.
<i>Synalpheus brooksi</i> Coutiere	Tampa Bay			21 fath.
<i>Synalpheus goodiei</i> Coutiere				6.5 fath.
<i>Synalpheus grampusi</i> Coutiere		27 04 00	83 21 15	26 fath.
<i>Synalpheus hemphilli</i> Coutiere	St. Martins Reef			
<i>Synalpheus herricki</i> Coutiere	Anclote section (150 specimens)			
<i>Synalpheus tanneri</i> Coutiere		29 15 30	85 29 30	27 fath.
PALAEEMONIDAE				
<i>Anchistoides antiguensis</i> (Schmitt)	West coast of Florida			
<i>Leander tenuicornis</i> (Say)	Punta Rassa, Fla.	28 46	84 49	
<i>Neopontonides beaufortensis</i> (Borradale)	Beaufort, N. C. and Tortugas Is.			
<i>Palaeomonetes vulgaris</i> (Say)	Apalachicola			
<i>Periclimenaeus maxillulidens</i> (Schmitt)	Off Cape San Blas	29 18 15	85 32 00	25 fath.
<i>Pontonia margarita</i> Smith	Off Panama City	30 06 00	85 45 00	
<i>Pontonia domestica</i> Gibbs	Port St. Joe			
HIPPIDAE				
<i>Emerita benedicti</i> Schmitt	Tampa Bay			
<i>Emerita portoricensis</i>	Pensacola			
ALBUNEIDAE				
<i>Albunea gibbesi</i> Stimpson	Santa Rosa Island			
<i>Albunea oxyphthalma</i> Leach	Santa Rosa Island			

List of Species Known or Expected to Occur Off the Coast of Northwestern Florida within the Thirty Fathom Line But Not Found During This Study—(Continued).

Species	Area	Latitude	Longitude	Depth
DROMIIDAE				
<i>Hypoconcha sabulosa</i> (Herbst)	South of St. George Island	28 47 30	84 37 00	24 fath.
<i>Hypoconcha spinosissima</i> Rathbun	South of St. George Island	28 46 00	84 49 00	26 fath.
DORIPPIDAE				
<i>Clythrocerus nitidus</i> (A. Milne Edwards)	SW of Cape San Blas			25 fath.
EBALIIDAE				
<i>Ebalia cariosa</i> A. Milne Edwards	Cedar Keys	29 18 15	85 32 00	2 fath.
<i>Lithadia cadaverosa</i> Stimpson	SW of Cape San Blas	29 14 00	85 29 15	25 fath.
<i>Osachila semilevis</i> Rathbun	Off Cap San Blas	29 19 30	83 46 00	10 fath.
<i>Spelaeophorus nodosus</i> (Bell)	Off Pepperfish Key			
PORTUNIDAE				
<i>Portunus ordwayi</i> (Stimpson)	Pescicola	28 02 30	87 43 45	
<i>Portunus sayi</i> (Gibbes)	Surface			
<i>Portunus selbac</i> (H. Milne Edwards)	Anclote section			
<i>Portunus spinicarpus</i> (Stimpson)	SW of Cape San Blas	29 14 00	85 29 15	25 fath.
XANTHIDAE				
<i>Carpoporus papulosus</i> Stimpson	SW of Cape San Blas	29 18 15	85 32 00	25 fath.
<i>Glyptoxanthus crosus</i> (Stimpson)	SW of Cape San Blas	29 17 00	85 30 45	26 fath.
<i>Leptodus agassizi</i> H. Milne Edwards	Off Carrabelle Light, N. by W., 14 2/3 miles			10 fath.
<i>Micropanope nuttingi</i> (Rathbun)	SW of Cape San Blas	28 46 00	84 49 00	25 fath.
<i>Micropanope sculptipes</i> Stimpson	South of St. George Island			26 fath.
<i>Micropanope xanthiformis</i> A. Milne Edwards	Cedar Keys			
<i>Panopeus rugosus</i> A. Milne Edwards	North Key section	28 55 30	83 02 00	25 fath.

List of Species Known or Expected to Occur Off the Coast of Northwestern Florida within the Thirty Fathom Line But Not Found During This Study—(Continued).

Species	Area	Latitude	Longitude	Depth
<i>Pilumnus floridanus</i> Stimpson	Cedar Keys Aucilla section Aucilla section	29 44 09	84 06 30	low tide
<i>Pilumnus lacteus</i> Stimpson		29 54 00	84 06 00	7 fath.
<i>Pilumnus pannosus</i> Rathbun				4.5 fath.
PINNOTHERIDAE				
<i>Dissodactylus borradalei</i> Rathbun	Cedar Keys Off St. Martins Reef	26 33 30	83 15 30	27 fath.
<i>Parapinnixa hendersoni</i> Rathbun		28 45 00	85 02 00	30 fath.
<i>Pinnotheres hemphilli</i> Rathbun				Between tides
<i>Pinnotheres moseri</i> Rathbun		28 43	82 56	17 feet
MAJIDAE				
<i>Aepinus septemspinus</i> (A. Milne Edwards)	S. of Cape San Blas SE. of Apalachicola S. of Cape San Blas SE. of Cape San Blas SE. of Apalachicola North Key section S. of Dog Island Off St. Martins St. Martins section Deadmans Bay section S. of Dog Island Pepperfish Key section	29 14 00	85 29 15	25 fath.
<i>Anasinus latus</i> Rathbun		28 46 00	84 49 00	26 fath.
<i>Arachnopsis filipes</i> Stimpson		29 18 15	85 32 00	25 fath.
<i>Batrachonotus fragosus</i> Stimpson		28 45 00	85 02 00	30 fath.
<i>Colloides trispinosus</i> Stimpson		28 45 00	85 02 00	26 fath.
<i>Epialtus dilatatus</i> A. Milne Edwards		29 05 00	83 22 30	5.5 fath.
<i>Macrocoelata septemspinus</i> (Stimpson)				
<i>Mithrax acuticornis</i> Stimpson		28 47 30	84 37 00	24 fath.
<i>Pitho laevigata</i> (A. Milne Edwards)		28 46 00	84 49 00	20 fath.
<i>Pitho lherminieri</i> (Schramm)		28 34 45	83 08 00	5.75 fath.
<i>Stenocionops furcata</i> coelata (A. Milne Edwards)	29 43 40	83 49 45	5.25 fath.	
<i>Tyche emarginata</i> White	28 47 30	84 37 00	24 fath.	
	29 21 00	83 32 00	6.75 fath.	
PARTHENOPIIDAE				
<i>Cryptopodia concava</i> Stimpson	S. of Cape San Blas North Key section Off Cape St. George	28 45 00	85 02 00	30 fath.
<i>Mesorhoca sexspina</i> Stimpson		29 02 30	83 14 00	25 fath.
<i>Solenolambrus tenellus</i> Stimpson		28 45 00	85 02 00	30 fath.

Parthenope serrata (H. Milne Edwards). (8, 25). One specimen was obtained by dredge about six miles SE of Alligator Point in the open Gulf in August, 1953, by H. J. Humm.

DISCUSSION

A total of 113 species and subspecies of decapods (72 genera, 22 families) have thus far been collected in inshore waters of Franklin and Wakulla counties from depths of less than six fathoms. An additional 62 species not yet obtained in this area may be expected to occur within the 30 fathom line along the northwest Florida coast (Table 1). Of this group, 28 species were taken by the U. S. Fish Commission vessel *Albatross* in depths of 20 to 30 fathoms which, in these waters occur more than 50 miles offshore. If these 28 species are eliminated as of unlikely occurrence in inshore waters, there remain but 32 known species to be expected in the Alligator Harbor area in addition to the 113 species reported in this paper.

Schmitt (1924) compared the number of decapod species found within the 100 fathom line of the Tortugas Islands with those found within that line in other places. The 125 species found at Tortugas were compared with the 51 species known at that time from Woods Hole, 73 for the entire New England coast (Rathbun, 1905), 120 at Bermuda, 137 at Beaufort, N. C., and 70 from San Francisco Bay and adjacent waters. These are relatively low figures compared with the 242 species known from Puerto Rico by 1902. Rathbun (1933) and Schmitt (1935b) listed 315 species from Puerto Rico, but these included offshort collections to a depth of 278 fathoms.

The decapod fauna of the Alligator Harbor area is notably similar to that of Beaufort, N. C.; 81 of the species found here also occur at Beaufort. Only 23 of the species found locally are also known from the New England coast, while 53 local species are reported from Puerto Rican waters. The local decapod fauna appears to be more closely related to that of Beaufort, N. C., than to that of the Tortugas. Thirteen of the local species appear to be confined to the west coast of Florida or the northern Gulf coast. Another 15 species are found in this area and at Beaufort, but are not known from the Florida Keys.

Ten miles offshore southeast of Alligator Point near whistle buoy 26, forty species have been taken. Sixty-two species were collected within Alligator Harbor, but the number approaches 70 if the sand bar at the harbor mouth and the outer beach of Alligator Point are

included. Probably the four to six fathom water around the whistle buoy was much less thoroughly sampled than the shallow waters of the harbor.

The three new species are from shallow water. A small form of *Pinnixa chaetoptera*, the most abundant representative of the genus in local waters, apparently has not been reported previously.

ACKNOWLEDGMENTS

I am especially indebted to Dr. Fenner A. Chace, Jr., Curator, Division of Marine Invertebrates, United States National Museum, for the identification of many less well known species, for critical review of the paper, for making facilities available at the National Museum, and for much helpful assistance.

I am also grateful to Dr. Irene Boliek of Florida State University for translations and other assistance; to Dr. Harold J. Humm of Duke University who directed the study and collected many specimens; and to Miss Sylvia A. Earle, a student at Duke University, for her preparation of the figures.

SUMMARY

A survey of the decapod fauna of Alligator Harbor and adjacent littoral areas from St. Marks Light to Apalachicola was undertaken from June, 1952, to April, 1953. Previous collections are also reported. The most intensive collecting was done in Alligator Harbor and along Alligator Point, near St. Marks Light and in the vicinity of buoy 26.

A total of 113 species and subspecies of decapods in 72 genera and 22 families have thus far been taken by the author and other personnel from the Florida State University Marine Laboratory in the area studied. Each species taken is discussed in the annotated list. A key for the determination of the species was compiled from available literature and personal findings. Three proposed new species, one in the genus *Paguristes* and two in the genus *Pinnixa*, are described.

Sixty-two other species which either have been found or may be expected to occur off the northwest coast of Florida within the 30 fathom line are listed.

The ranges of several species have been extended by this study. These include *Periclimenaeus wilsoni*, *Typton tortugae*, *Paguristes*

tortugae, and *Leptodius floridanus*, all of which were not previously known in the Gulf north of the Tortugas. A form of *Pinnixa chaetopterana* not previously known was found to be a commensal of *Callinassa jamaicensis louisianensis*.

LITERATURE CITED

ANDERSON, W. W., and M. J. LINDNER

1. 1943. A provisional key to the shrimps of the family *Penaeidae* with special reference to American forms. Trans. Amer. Fish Soc. 73: 286-319.

BEHRE, E. H.

2. 1950. Annotated list of the fauna of the Grande Isle region, 1928-1946. Occ. Papers Marine Lab. L. S. U., No. 6: 66 pp.

BURKENROAD, M. D.

3. 1934. The *Penaeidea* of Louisiana with a discussion of their world relationships. Bull. Amer. Mus. Nat. Hist. 68: 61-143.
4. 1939. Further observations on the *Penaeidea* of the northern Gulf of Mexico. Bull. Bing. Oceanogr. Lab. 6. (art. 6), 62 pp.

CARLGREN, O., and J. W. HEDGPETH

5. 1952. *Actinaria*, *Zoantharia*, and *Ceriantharia* from shallow water in the northwestern Gulf of Mexico. Publ. Inst. of Marine Sci. (Univ. of Texas) 2: 141-172.

CHACE, F. A., JR.

6. 1942. Six new species of decapod and stomatopod crustacea from the Gulf of Mexico. Proc. New Eng. Zool. Club 19: 79-92.

COUTIERE, H.

7. 1909. The American species of snapping shrimps of the genus *Synalpheus*. Proc. U. S. Nat. Mus. 51: 569-579.

HAY, W. P., and C. A. SHORE

8. 1918. The decapod crustaceans of Beaufort, N. C., and surrounding region. Bull. Bur. of Fish. 35: 371-475.

HOLTHUIS, L. B.

9. 1951. A general revision of the Palaemonidae (*Crustacea Decapoda Natantia*) of the Americas. I. The subfamilies *Euryrhynchinae* and *Pontoniinae*. Allan Hancock Foundation Publ., Occasional Paper No. 11, 331 p. (Univ. of S. Calif. Press.)
10. 1952. A general revision of the Palaemonidae (*Crustacea Decapoda Natantia*) of the Americas. II. The subfamily *Palaemoninae*. Allan Hancock Foundation Publ., Occasional Paper No. 12. 369 p. (Univ. of S. Calif. Press.)

HUMES, A. G.

11. 1941. Notes on *Octolasmis mulleri* (Coker), a barnacle commensal on crabs. Trans. Amer. Micro. Soc. 60: 101-104.

IDYLL, C. P.

12. 1950. Report on the present status of the Franklin County shrimp industry. Fla. State Board of Conser. Mimeo. Sep., 14 p.

IVES, J. E.

13. 1891. Crustacea from the northern coast of Yucatan, the harbor of Vera Cruz, the west coast of Florida, and the Bermuda islands. Proc. Acad. Nat. Sci. Phila. 42: 176-207.

KINGSLEY, J. S.

14. 1879. On a collection of Crustacea from Virginia, North Carolina, and Florida, with a revision of the *Crangonidae* and *Palaemonidae*. Proc. Acad. Nat. Sci. Phila. 30: 383-427.

LUNZ, G. R., JR.

15. 1937a. *Xanthidae* (mud crabs) of the Carolinas. Charleston Museum Leaflet No. 9, 9-28.
16. 1937b. Notes on *Callinassa major* Say. Charleston Museum Leaflet No. 10, 15 p.
17. 1945. Carolina shrimps of the genus *Eusicyonia*. Charleston Museum Leaflet No. 20, 12 p.

McRAE, E. D.

18. 1950. An ecological study of the xanthid crabs in the Cedar Key area. Unpubl. master's thesis, Univ. of Florida. 72 p.

MILES, R. M.

19. 1951. An analysis of the "trash fish" of shrimp trawlers operating in Apalachicola Bay and adjacent Gulf of Mexico. Unpubl. master's thesis, Florida State Univ. 45 p.

PEARSE, A. S.

20. 1952. Parasitic crustaceans from Alligator Harbor, Florida. Jour. Fla. Acad. Sci. 15: 187-243.

PEARSE, A. S., H. J. HUMM, and G. W. WHARTON

21. 1942. Ecology of sand beaches at Beaufort, N. C. Ecological Monographs 12: 135-190.

RATHBUN, MARY J.

22. 1901. The *Brachyura* and *Macrura* of Porto Rico. Bull. Bureau of Fisheries 20(part 2): 1-127. (1900)
23. 1905. List of the *Crustacea*. Fauna of New England. Occasional Papers, Boston Soc. Nat. Hist. 7: 1-117.
24. 1918. The grapsoid crabs of America. Bull. U. S. Nat. Museum 97, 461 p.

25. 1925. The spider crabs of America. Bull. U. S. Nat. Museum 129, 613 p.
26. 1930. The canceroid crabs of America of the families *Euryalidae*, *Portunidae*, *Atelecyclidae*, *Canceridae*, and *Xanthidae*. Bull. U. S. Nat. Museum 152, 609 p.
27. 1933. Brachyuran crabs of Porto Rico and the Virgin Islands. Sci. Survey of Porto Rico and the Virgin Islands 15: 1-121.
28. 1937. The oxystomatous and allied crabs of America. Bull. U. S. Nat. Museum 166, 272 p.

SCHMITT, W. L.

29. 1924. Observations on the Decapod Crustacea of Tortugas. Carnegie Inst. of Wash., Yearbook 23: 200-201.
30. 1930. Some observations on the Crustacea of Tortugas, Florida. Carnegie Inst. of Wash., Yearbook 29: 343-346.
31. 1935a. Mud shrimps of the Atlantic coast of North America. Smithsonian Misc. Coll. 93: 1-21.
32. 1935b. *Crustacea Macrura* and *Anomura* of Porto Rico and the Virgin Islands. Sci. Survey of Porto Rico and the Virgin Islands 15: 125-227.

FLORIDA OSCILLATORIACEAE III ¹

C. S. NIELSEN
Florida State University

4. *Phormidium* Kützing

Filaments sheathed, simple, adhering into a pannose stratum or more rarely floating attached at base and edges, never separating without rupturing. Sheaths thin, hyaline, mucose, agglutinated, diffuent in part or all. Trichomes cylindrical, constricted at cross-walls in several species, even moniliform, apex more often attenuate, straight or curved, capitate or not capitate, never conspicuously spiraled; membrane of apical cells in many species thickened above into a calyptra. Plants terrestrial or aquatic, not infrequently halophilic.

Section I. Moniliformia. Trichomes exceedingly torulose, even moniliform, apex neither curved nor capitate.

A. Trichomes up to 4 microns wide.

1. Thermal or saline. Trichomes 1.2 - 2.3 microns wide; cells subquadrate 1. *P. fragile*
2. Fresh-water, damp soil. Trichomes 2 - 3 microns wide; cells subquadrate to 1/2 shorter than diameter 2. *P. minnesotense*

Section II. Euphormidia. Trichomes rarely and scarcely torulose, apices straight or curved, in many species capitate.

A. Trichomes up to 3 microns wide B.

B. Stratum purple-violet.

1. Filaments exceedingly tortuous. Trichomes never constricted at cross-walls; cross-walls characterized by four protoplasmic granules 3. *P. purpurascens*

BB. Stratum blue-green or olive.

1. Stratum thick, coriaceous. Trichomes never constricted at cross-walls; 2 - 2.5 microns wide, apices straight, obtuse 4. *P. valderianum*

¹ Concluded from Quart. Journ. Fla. Acad. Sci., 18(2): 84-112, 1955.

2. Stratum thin, membranaceous. Trichomes slightly constricted at cross-walls, 1 - 2 microns wide, apices later attenuate and uncinata; cross-walls not granular
..... 5. *P. tenue*
 3. Stratum mucose, membranaceous; trichomes markedly constricted at cross-walls, 1 - 2.5 microns wide; cells subquadrate to twice diameter in length 6. *P. Weisii*
- AA. Trichomes 3 microns or more wide B.
- B. Trichome apices straight, never capitate a.
 - a. Apical cell obtuse conical; plants never calcium encrusted.
 1. Filaments nearly straight. Trichomes 3 - 5 microns wide; cross-walls obscured by protoplasmic granules 7. *P. inundatum*
 2. Filaments exceedingly flexuous. Trichomes 3 - 5 microns wide; cells scarcely as long as diameter; cross-walls conspicuous 8. *P. papyraceum*
 - aa. Apical cell not or scarcely attenuate; truncate.
 1. Sheaths thin, fragile, exceedingly diffluent. Trichomes 4.5 - 12 microns wide; cells longer than diameter to just 1/2 diameter in length
..... 9. *P. Retzii*
- BB. Trichome apices straight, capitate a.
- a. Trichomes slightly constricted at cross-walls.
 1. Halophilic. Trichomes 5 microns wide; cells subquadrate or longer than diameter
..... 10. *P. submembranaceum*
 2. Fronds penicillate. Trichomes 6 microns wide; cells quadrate to twice as long as diameter, 7 - 12 microns 11. *P. penicillatum*
 - aa. Trichomes never constricted at cross-walls.
 1. Thermal or fresh-water. Trichomes elongate, flexuous, 4.5 - 9 microns wide, apices long and gradually attenuate; cells subquadrate; apical cell obtuse-truncate 12. *P. favosum*

2. Trichome apices scarcely attenuate, 6 - 8 microns wide; apical cell obliquely truncate above
----- 13. *P. calidum*
3. Fresh-water. Trichomes straight, fragile, apices extremely and briefly attenuate, 5.5 - 11 microns wide; cells up to 1/4 shorter than diameter; apical cell straight conical above ----- 14. *P. subfuscum*

BBB. Trichome apices more or less curved, capitate.

1. Plants blue-green or dark-yellow; aquatic; trichomes 6 - 9 microns wide; apex conspicuously uncinuate or shortly spiralled ----- 15. *P. uncinatum*
2. Plants blue-green or dark-yellow; terrestrial; trichomes 4 - 7 microns wide; apex scarcely curved, generally straight ----- 16. *P. autumnale*

1. *Phormidium fragile* Gomont. Monogr. Oscill. Ann. Sci. Nat. Bot. VII 16: p. 163, pl. 4, f. 13-15 (1892).

Stratum mucose, lamellose, yellow- or darkly blue-green. Sheaths dissolving into gelatinous fibrous mucus, not turning blue with chlor-zinc-iodine. Trichomes more or less flexuous, brilliant blue-green, diversely entangled or almost parallel, moniliform, apices attenuate, 1.2 - 2.3 microns wide; cells subquadrate, 1.2 - 3 microns long; protoplasm never granular; apical cell acute conical; calyptra absent.

Leon county: walls of salt water pool, courtyard of History bldg. F.S.U. campus, Tallahassee, *H. J. Humm*, 31 Dec. 1952 (C, D). Wakulla county: Shell Point, Gulf of Mexico, on oyster shells in channel, *Nielsen 03*, 7 Nov. 1952 (C, D, F).

2. *Phormidium minnesotense* (Tild.) Drouet. Field Mus. Bot. Ser. 20 (6): p. 136 (1942).

Stratum beautifully blue-green, thin, gelatinous, with diffuent hyaline sheaths; never turning blue with chlor-zinc-iodine; trichomes blue-green, rigid, fragile, straight, arranged compactly and parallel, 2 - 3 microns wide, constricted at cross-walls, not attenuate toward apices; cells subquadrate to 1/2 shorter than diameter, cross-walls not granular, homogeneous protoplasm; apical cell rotund, membrane not thickened above.

Alachua county: Sink I, Hibiscus pk., Gainesville, *Brannon 178*, 10 June 1943 (C, D). Lake county: fresh-water, Leesburg, *Brannon 283*, 28 July 1944 (C, D).

The Brannon specimens were found with *Fremyella diplosiphon* (B. & F.) Dr. and *Oscillatoria tenuis* Gom.

3. *Phormidium purpurascens* Gomont. Monogr. Oscill. Ann. Sci. Nat. Bot. VII 16: p. 166, pl. 4, f. 19 (1892).

Stratum compact, coriaceous, dark-violet. Filaments exceedingly tortuous, closely entangled. Sheaths at first firm, papery, finally diffuent and agglutinated, not turning blue with chlor-zinc-iodine. Trichomes pale dark-violet, apex neither attenuate nor curved, never constricted at cross-walls, 1.5 - 2.5 microns wide; cells subquadrate to twice trichome diameter in length, 2 - 4.5 microns long; cross-walls characterized by four protoplasmic granules; apical cell rotund; calyptra absent.

Wakulla county: Little Spring, Newport, *Nielsen, Madsen & Crowson 254*, Aug. 1948 (C, D, F).

4. *Phormidium valderianum* Gomont. Monogr. Oscill. Ann. Sci. Nat. Bot. VII 16: p. 167, pl. 4, f. 20 (1892).

Stratum slippery, expansive, lamellose, up to 3 cm. thick, composed of discolored lamellae, above darkly green, below uncolored. Filaments flexuous, densely entangled. Sheaths firm, papery, finally diffuent and agglutinated in a persistent mucus, turning blue with chlor-zinc-iodine. Trichomes blue-green, apices straight, not attenuate, never constricted at cross-walls, 2 - 2.5 microns wide; cells longer than diameter, 3.3 - 6.7 microns long; cross-walls characterized by 2 or 4 protoplasmic granules; apical cell rotund; calyptra absent.

Dade county: culture of marine algae, Univ. of Miami Lab., Coral Gables, *R. Lasker*, 24 Apr. 1952 (C, D). Marion county: Orange Lake, *Brannon 153*, 14 Mar. 1943 (C, D). Wakulla county: small sulphur spring, 1/2 mile north of Newport, *Drouet, Crowson & Thornton 11354*, 25 Jan. 1949 (C, D, F); surface of submerged log, Log Sulphur Spring, Newport, *C. Jackson 1010*, 11 Nov. 1950 (C, D, F).

5. *Phormidium tenue* Gomont. Monogr. Oscill. Ann. Sci. Nat. Bot. VII 16: p. 169, pl. 4, f. 23-25 (1892).

Stratum brilliant blue-green, thin, membranaceous, expansive. Filaments elongate, nearly straight, densely entangled. Sheaths thin, finally dissolving into a fibrose mucus, turning blue with chlor-zinc-iodine. Trichomes brilliant blue-green, straight, slightly constricted at cross-walls, generally cells indistinct, apices at first straight, finally uncinatate and attenuate, never capitate, 1 - 2 microns wide; cells up to 3 times longer than trichome diameter, 2.5 - 5 microns long; protoplasm homogeneous; apical cell finally acute conical; calyptra absent.

Alachua county: Sink I, Hibiscus pk., Gainesville, *Brannon 129, 284*, Apr. 1942 (C, D); Sulphur Springs, *Brannon 293*, 15 Mar. 1945 (C, D). Citrus county: Lakes Tsala and Apopka, *Brannon 131*,

9 Dec. 1942 (C, D). Indian River county: sulphur spring, McKee Jungle garden, Vero Beach, *S. H. Grove* & *E. Sella*, 25 Mar. 1951 (C, D). Jackson county: wayside pk., U. S. 90, Marianna, *Nielsen, Madsen* & *Crowson* 312, 31 Aug. 1948 (C, D, F). Lake county: Robinson Lake, Leesburg, *Brannon* 284, 15 June 1944 (C, D). Leon county: Lake Iamonia dam, *Nielsen* & *Madsen* 409, Aug. 1948 (C, D, F). Liberty county: Apalachicola river flood plain, Bristol, *Nielsen* & *Madsen* 439, Aug. 1948 (C, D, F). Marion county: Orange Lake, *Brannon* 158, 14 Mar. 1943 (C, D). Wakulla county: picnic spring, Newport, *Nielsen, Madsen* & *Crowson* 246, Sept. 1948 (C, D, F); Log Sulphur Spring, in woods along St. Marks river, one mile north of Newport, *Drouet, Madsen* & *Crowson* 11327, 11328, 11330, 11331, 25 Jan. 1949 (C, D, F); small sulphur spring, 1/2 mile north of Newport, *Drouet, Crowson* & *Thornton* 11344A, 11346, 11358, 11359, 11367, 25 Jan. 1949 (C, D, F); *Nielsen* 1, 2, 3, 15 Oct. 1950 (C, D, F); Newport, *J. E. Harmon* 22, 11 Nov. 1950 (C, D, F); *Nielsen* 6, 8, 23 July 1952 (C, D, F).

The following were commonly found with the cited specimens: *Oscillatoria amoena* Gom., *O. chalybea* Gom., *O. articulata* Gardn., *Spirulina major* Gom. and *S. subtilissima* Gom.

6. *Phormidium Weisii* Drouet. Field Mus. Bot. Ser. 20 (1): p. 10 (1939).

Stratum blue-green or blackish, mucose even membranaceous; trichomes straight to wavy, fragile, parallelly arranged in an amorphous hyaline mucus, never turning blue with chlor-zinc-iodine, markedly constricted at cross-walls, never torulose, 1 - 2.5 microns wide; above straight or curved and uncinata, gradually and acutely attenuate to apices; cells subquadrate or up to twice the diameter, 1.5 - 5 microns long; protoplasm of entire cell homogeneous, rarely finely granular; cross-walls conspicuous, never granular; apical cell acute conical, never capitate, without calyptra.

Florida: southwest Florida, *J. D. Smith*, Mar. 1878 (C, D).

The collection has been reported for the state as *Phormidium Boryanum* Wolle in Bull. Torr. Club 6: 283 (1879) (Drouet 1939).

7. *Phormidium inundatum* Gomont. Monogr. Oscill. Ann. Sci. Nat. Bot. VII 16: p. 172, pl. 4, f. 31-32 (1892).

Stratum blue-green, membranaceous. Filaments almost straight, fragile (in dried specimens). Sheaths thin, dissolving into an amorphous mucus, turning blue with chlor-zinc-iodine. Trichomes blue-green, straight or arcuate, not constricted at cross-walls, apices straight, shortly attenuate, not capitate, 3 - 5 microns wide; cells subquadrate to longer than diameter,

4 - 8 microns long; cross-walls obscured by protoplasmic granules; apical cell obtuse conical; calyptra absent.

Monroe county: in shallow fresh-water pond on coral rock, Lower Matecumbe Key, A. M. Scott 87, 19 Oct. 1947 (C, D). Pinellas county: Bellair, waterfall, Nielsen, Madsen & Crowson 465, 466, 9 Sept. 1948 (C, D, F).

Specimens were collected with *Lyngbya Lagerheimii* Gom. and *Oscillatoria proboscidea* Gom.

8. *Phormidium papyraceum* Gomont. Monogr. Oscill. Ann. Sci. Nat. Bot. VII 16: p. 173, pl. 5, f. 3-4 (1892).

Stratum expansive, black-green, glisteningly silky, thin, leathery, fragile on drying. Filaments elongate, exceedingly flexuous, most densely intricate. Sheaths thin, papery, occasionally diffuent, turning blue with chlor-zinc-iodine. Trichomes blue-green, not constricted at cross-walls, apices straight, briefly attenuate, not capitate, 3 - 5 microns long, occasionally filled with protoplasmic granules; cross-walls generally conspicuous, never granular; apical cell obtusely conical; calyptra absent.

Columbia county: Ichtucknee Springs Run, Brannon 80, 105, 23 July 1942 (C, D).

The Brannon specimen contained also *Amphithrix janthina* B. & F.

9. *Phormidium Retzii* Gomont. Monogr. Oscill. Ann. Sci. Nat. Bot. VII 16: p. 175, pl. 5, f. 6-9 (1892).

Stratum very blue-green, or darkly steel blue, wide, compact, or more rarely in waving penicillate fascicles, tree-like, here and there branched, attached at base. Filaments diversely entangled, more or less straight, fragile. Sheaths thin, fragile, usually continuously dissolving into an amorphous mucus, not turning blue with chlor-zinc-iodine; trichomes blue-green, generally not constricted at cross-walls, more rarely torulose, apices straight, not capitate, 4.5 - 12 microns wide; cells shorter or longer than trichome diameter, 4 - 9 microns long, filled with protoplasmic granules, occasionally obscuring cross-walls; cross-walls not granular; apical cell scarcely attenuate, truncate, membrane slightly thickened above.

Forma *fasciculata*. Fascicles attached at base, penicillate or arbuscular, here and there branched, waving.

Forma *rupestris*. Trichomes torulose toward apex.

Leon county: Natural Bridge, Nielsen, Madsen & Crowson 80, May 1948 (C, D, F); Ochlockonee river on U. S. 90, Nielsen, Madsen & Crowson 103, June 1948 (C, D, F).

The species has been reported for the state as *Lyngbya vulgaris* (Kg.) Kirsch. in Wolle, F. W. Alg. 300 (1887). The Smith specimen

(Tilden, 102) of *P. Retzii* Gom. has been referred to *Schizothrix Friesii* Gom. (Drouet, 1939).

10. *Phormidium submembranaceum* Gomont. Monogr. Oscill. Ann. Sci. Nat. Bot. VII 16: p. 180, pl. 5, f. 13 (1892).

Stratum membranaceous, coriaceous, black-green. Trichomes lacking sheaths, densely entwined, with abundant amorphous mucus, not turning blue with chlor-zinc-iodine, agglutinated, blue-green, constricted at cross-walls, 5 microns wide, apex gradually straight and long, attenuate-capitate; cells subquadrate to twice the trichome diameter in length, 4 - 10 microns long; protoplasm homogeneous, apical cell with depressed-conical calyptra.

Dade county: on *Pedalion alata* from seawall at end of road leading down to Biscayne Bay at Cutler (south of Miami), *H. J. Humm*, 10 Jan. 1946 (C, D). Levy county: intertidal on woodwork of municipal wharf, Way key, Cedar Keys, *Drouet & Nielsen 11111*, 22 Jan. 1949 (C, D, F).

11. *Phormidium penicillatum* Gomont. Bull. Soc. Bot. Fr. 40: p. CLIX (1893).

Fronds attached at base, penicillate, tortuous, exceedingly elongate, waving, in lower portion filiform, discolored, gelatinous, above extended and somewhat clathrate, in living plants chestnut brown, in dry lilac. Filaments exceedingly elongate, curved, reticulately intricate. Sheaths gelatinous, becoming progressively entirely diffuent into an amorphous mucus, never turning blue with chlor-zinc-iodine. Trichomes sparse at base of frond, in upper portion numerous and free at extremes, elongate, flexuous, pale brown-lilac (in dried specimens), 6 microns wide, lightly constricted at cross-walls, apices straight, not or scarcely attenuate, sub-capitate; cells from trichome diameter to twice as long, 7 - 12 microns long, filled with very small protoplasmic granules; cross-walls never granular; apical cell with rotund to depressed-conical calyptra.

Monroe county: south shore near Battery, Key West, *R. Thaxter*, Feb. 1898 (C, D).

12. *Phormidium favosum* Gomont. Monogr. Oscill. Ann. Sci. Nat. Bot. VII 16: p. 180, pl. 5, f. 14-15 (1892).

Stratum blackish blue-green, same on drying, moderately expansive, papery or wide, attached at base, floating. Trichomes generally lacking sheaths, agglutinated in an amorphous mucus, not turning blue with chlor-zinc-iodine, blue-green, elongate, more or less flexuous, not torulose, 4.5 - 9 microns wide, straight or very loosely spiralled toward ends, apices gradually attenuate, exceedingly capitate; cells quadrate to 1/2 trichome diameter in length, 3 - 7 microns long; cross-walls characterized by a double line of pearly granules; apical cell obtuse-truncate, calyptra subhemispherical.

Var. *alpha*. Trichomes straight above.

Var. *beta*. Trichomes twisted above in very loose spirals.

Wakulla county: Club sulphur spring, one mile north of Newport, *Nielsen, Madsen & Crowson 219, 223, 225, 235, 240*, Aug. 1948 (C, D, F); *Drouet, Crowson & Thornton 11383, 11385, 11396*, 25 Jan. 1949 (C, D, F).

13. *Phormidium calidum* Gomont. Monogr. Oscill. Ann. Sci. Nat. Bot. VII 16: p. 182, pl. 5, f. 16 (1892).

Stratum thin, membranaceous, obscurely green. Trichomes devoid of sheaths, parallelly agglutinated into an amorphous mucus, obscurely blue-green, nearly straight, not torulose, 6-8 microns wide, apices straight scarcely attenuate and capitate; cells subquadrate to 1/2 diameter, 3/8 microns long; cross-walls non-granular; apical cell with obliquely depressed-conical calyptra.

Alachua county: in Hatchet creek, Gainesville, *Brannon 38*, 8 Jan. 1942 (C, D).

14. *Phormidium subfuscum* Gomont. Monogr. Oscill. Ann. Sci. Nat. Bot. VII 16: p. 182, pl. 5, f. 17-20 (1892).

Stratum broadly expanded, blackish-green or blackish-olive, wooly, thin, lamellose. Filaments straight, fragile, short, parallel, agglutinated into a lamellated mucus of diffuent sheaths. Sheaths not turning blue with chlor-zinc-iodine. Trichomes obscurely blue-green, not torulose, 5.5-11 microns wide, apices straight, capitate, more or less briefly attenuate; cells 1/2-1/4 shorter than diameter of trichome, more rarely subquadrate, 2-4 microns long, densely filled with protoplasmic granules; apical cell with rotund calyptra or straight cone.

Var. *alpha*. (*Oscillatoria subfusca* Agardh). Trichomes 8-11 microns wide, apex briefly attenuate.

Var. *beta*. (*Phormidium Joannianum* Kützing). Trichomes 5.5-7 microns wide, apex more often somewhat long attenuate.

15. *Phormidium uncinatum* Gomont. Monogr. Oscill. Ann. Sci. Nat. Bot. VII 16: p. 184, pl. 5, f. 21-22 (1892).

Stratum broadly expanded, blackish-green or darkly to reddish-black, attached, thin, firm, even floating, attached at base. Filaments straight or subflexuous. Sheaths mucose, agglutinated, distinct or entirely dissolving into abundant amorphous mucus, not turning blue with chlor-zinc-iodine. Trichomes blue-green, not constricted at cross-walls, 6-9 microns wide, apices shortly attenuate, exceedingly capitate, curved or shortly spiralled; cells 1/2 to 1/3 (rarely subquadrate) of trichome diameter in length, 2-6 microns long; cross-walls frequently granular; apical cell with calyptra rotund or depressed—conical.

Alachua county: in Hatchet Creek, Gainesville, *Brannon 146, 147*, 10 Feb. 1943 (C, D); Club spring, north of Newport, *Nielsen, Madsen & Crowson 178*, July 1948 (C, D, F).

16. *Phormidium autumnale* Gomont. Monogr. Oscill. Ann. Sci. Nat. Bot. VII 16: p. 187, pl. 5, f. 23-24 (1892).

Stratum expanded, fragile, glistening, blackish blue-green, occasionally yellow-dark. Filaments straight, more rarely flexuous, diversely entwined. Sheaths firm, fragile, mucose, distinct or dissolving into amorphous mucus and agglutinated, not turning blue with chlor-zinc-iodine. Trichomes blue-green, never constricted at cross-walls, 4-7 microns wide, apices shortly attenuate and exceedingly capitate, scarcely curved or straight; cells quadrate to 1/2 trichome diameter in length, 2-5 microns long. Cross-walls frequently granular; apical cell with rotund calyptra.

Alachua county: in H. E. Brantley greenhouse, U. of Fla. *Brannon 43, 74, 128, 130*, 17 Feb. 1942 (C, D). Franklin county: intertidal on woodwork on shore of Apalachicola bay in S.E. part of Apalachicola, *Drouet & Nielsen 10992, 10994, 11004*, 16 Jan. 1949 (C, D, F). Jackson county: U. S. 90, Wayside pk., Marianna, *Nielsen, Madsen & Crowson 310*, 31 Aug. 1948 (C, D, F); Fla. 71, 5 miles south of Marianna, *Nielsen and Madsen 345*, 31 Aug. 1948 (C, D, F); Merritt's mill, pond, Blue Springs, *Nielsen*, 23 Oct. 1950 (C, D, F). Lake county: on rocks in inlet of pool, in western part of municipal pk., Leesburg, *Drouet & Brannon 11042*, 19 Jan. 1949 (C, D). Leon county: wet sand in greenhouse, F.S.U., Tallahassee, *Drouet & Crowson 10453*, 5 Jan. 1949 (C, D, F); F.S.U. greenhouse, Tallahassee, *Nielsen*, 4 Nov. 1952 (C, D, F). Martin county: from shell of turtle deposited under a peat bog, 14 miles west of Palm City, *Sackett*, 1939 (C, D). Okaloosa county: on cement in outlet of sewer into Santa Rosa sound at west end of bridge on U. S. 98, Ft. Walton, *Drouet, Nielsen, Madsen, Crowson & Pates 10642, 10647*, 9 Jan. 1949 (C, D, F). Orange county: top soil of flower pot, Orlando, *Brannon 351A*, 5 June 1948 (C, D, F). Polk county: experiment station greenhouse, Lake Alfred, *Nielsen & Madsen 452*, Sept. 1948 (C, D, F). Wakulla county: on mud beside St. Marks river, Newport, *Drouet, Madsen & Crowson 10823*, 13 Jan. 1949 (C, D, F); woodwork, submerged in swiftly running water, Club spring north of Newport, *Nielsen 11*, 23 July 1952 (C, D, F).

Specimens were found with: *Gloecapsa minuta* (Kutz.) Hollerb., *Nostoc* spores, *Oscillatoria brevis* Gom., *O. tenuis* Gom. and *Scenedesmus* sp.

Phormidium persicinum (Reinke) Gomont has been reported from Dry Tortugas by Taylor (1928).

5. *Skujaella* (Gom.) J. DeToni (*Trichodesmium* Ehrenberg)

Trichomes cylindrical, non-sheathed, aggregated in temporary mucus into scale-like fascicles, discreet, free-floating, apices straight, attenuate, slightly capitate. Apical cell truncate-conical, with convex calyptra.

1. Fascicles scarcely up to 1 mm. long. Trichomes straight, torulose, 7 - 11 microns, more rarely up to 21 microns wide; cells subquadrate to 1/3 trichome diameter in length
----- 1. *S. erythraeum*
2. Fascicles up to 5 mm. long. Trichomes straight, not torulose, 13 - 22 microns wide; cells always shorter than trichome diameter. No known records from Florida....2. *S. Hildebrandtii*
3. Fascicles up to 6 mm. long. Trichomes flexuous, funiform-contorted, not torulose, 7 - 16 microns wide, apices generally inflated; cells generally longer than trichome diameter
----- 3. *S. Thiebautii*

1. *Skujaella erythraeum* J. DeToni. Noter. Nomencl. Algol. IX, 292 (1939).

Fascicles very short, scarcely up to 1 mm. long, purple to blood red, bluish gray to green or dark in dried specimens. Trichomes straight, parallel, constricted at cross-walls, slender, apices long attenuate, wide, 7 - 11 microns, more rarely to 21 microns wide; cells subquadrate to 1/3 trichome diameter in length, 5.4 - 11 microns long, filled with large protoplasmic granules.

Dade county: culture of algae from Gulf Stream near Miami Beach, U. of Miami Marine Lab., Coral Gables, *Reuben Lasker*, 21 Mar. 1951 (C, D).

2. *Skujaella Hildebrandtii* J. DeToni. Noter. Nomencl. Algol. IX, 292 (1939).

Fascicles 2 - 5 mm. long, in dried specimens yellow-dark to dark green. Trichomes never constricted at cross-walls, apices briefly attenuate, 13 - 22 microns wide; cells always 1/3 trichome diameter in length, filled with small protoplasmic granules to homogeneous.

3. *Skujaella Thiebautii* J. DeToni. Noter. Nomencl. Algol. IX, 292 (1939).

Fascicles to 6 mm. long, dark green in dried specimens. Trichomes in middle part of fascicle funiform-contorted, at ends more free, never constricted at cross-walls, apices briefly attenuate or occasionally inflated, 7-16 microns wide; cells up to twice trichome diameter in length, more rarely subquadrate, 8-26 microns long, filled with large protoplasmic granules, often obscuring cross-walls.

Dade county: marine plankton tow, 2 miles east of Cape Florida, *Chas. C. Davis* 86, 18 Oct. 1947 (C, D); culture of algae from Gulf Stream near Miami Beach, U. of Miami Marine Lab., Coral Gables, *Reuben Lasker*, 21 Mar. 1951 (C, D); *Laster*, 1950 (C, D). Her-
nando county: on *Ruppia* sp., *Brannon* 558, 23 Oct. 1948 (C, D). Lee
county: marine plankton tow in bright yellow water, 1 mile south
of Useppa island, Pine Island sound, *Chas. C. Davis* 18, 28 Jan.
1947 (C, D).

LITERATURE CITED

BRANNON, MELVIN A.

1945. Factors affecting the growth of Myxophyceae in Florida. *Quart. Journ. Fla. Acad. Sci.* 8 (4): 296-303.
1952. Some Myxophyceae in Florida. *Quart. Journ. Fla. Acad. Sci.* 15 (2): 70-78.

CROWSON, DOROTHY E.

1950. The Algae of a Modified Brackish Pool. *Fla. State Univ. Studies* 1: 1-32.

DE TONI, J.

1939. Noterelle Di Nomenclatura Algologica IX. *Archivio Botanica* 15: 288-292.

DROUET, FRANCIS

1937. Some Myxophyceae from the Canal Zone. *Bull. Torrey Bot. Club* 64: 599-604.
1939. Francis Wolle's Filamentous Myxophyceae. *Field Mus. Nat. Hist. Bot. Series* 20 (2): 17-64.
1943. Myxophyceae of Eastern California and Western Nevada. *Field Mus. Nat. Hist. Bot. Series* 20 (7): 145-176.

FARLOW, W. G.

1875. List of the Marine Algae of the United States. *Proc. Amer. Acad. Arts & Sci.* 11: 351-380.
1876. List of the Marine Algae of the United States. *Report of the U. S. Fish Commission*, pp. 1-28.

GOMONT, M.

1892. Monographie des Oscillariees. *Ann. Sci. Nat. Bot.* VII. 15: 263-368.

HARVEY, WILLIAM H.

1857. *Nereis Boreali-Americana*. *Smithsonian Contribution XIX*: 1-40.

HUMM, HAROLD J.

1952. Notes on the Marine Algae of Florida. I. The Intertidal Rocks at Marineland. *Fla. State Univ. Studies* 7: 17-23.

MADSEN, GRACE C., and C. S. NIELSEN

1950. Check List of the Algae of Northern Florida II. *Quart. Journ. Fla. Acad. Sci.* 13: 1-19.

NIELSEN, C. S.

1954a. The Non-sheathed Oscillatoriaceae of Northern Florida. *Hydrobiologia VI* (3-4): 352-368.

1954b. The Multitrichomate Oscillatoriaceae of Florida. *Quart. Journ. Fla. Acad. Sci.* 17 (1): 25-42 and 17 (2): 87-104.

NIELSEN, C. S., and GRACE C. MADSEN

1948a. Preliminary Check List of the Algae of the Tallahassee Area. *Quart. Journ. Fla. Acad. Sci.* 11 (4): 111-117.

1948b. Check List of the Algae of Northern Florida I. *Quart. Journ. Fla. Acad. Sci.* 11 (2-3): 63-66.

SMITH, F. B., and H. R. ELLIS

1943. Preliminary Report on the Algal Flora of Some Florida Soils. *Proc. Fla. Acad. Sci.* 6 (1): 59-65.

TAYLOR, WILLIAM RANDOLPH

1928. Marine algae of Florida with special reference to the Dry Tortugas. *Papers from the Tortugas Laboratory (Carnegie Institution of Wash.)* 25: 1-219.

TILDEN, JOSEPHINE

1910. *Minnesota Algae*, Vol I, Bot. Series VIII, Minneapolis, Minn.

WOLLE, FRANCIS

1877. Fresh Water Algae III. *Bull. Torrey Bot. Club* 6 (35): 181-189.

1887. *Fresh Water Algae of the United States*. Bethlehem, Pa.

AMERICAN EDUCATION AND THE STONE WALL

G. G. BECKNELL

Department of Physics, University of Tampa

For many years the superiority in efficiency of English and European education has been quite apparent to scientists, although perhaps not so evident to our schools of education and their high priests of the educational art. For the last quarter century criticisms have emanated from all sections of this country commenting on the ignorance of high school, and even college, graduates in such major subjects as English, history, arithmetic, algebra, and plane geometry. And yet these young people hold diplomas that indicate, seemingly, how much time they have done in high school or college, and not how much of the school has penetrated their "intellohesions".

Our free public school system has become a sort of glorified sausage machine, with fresh meat fed in at one end and crowded out at the other with very little change in the product on the way, except that it is neatly packaged in a transparent wrapper called—a diploma.

An article in Harper's Magazine for November, 1954, bears the title "Can Teachers Read and Write?" It is an account of a university extension course given to twenty-eight students who were teachers in the public schools of the state, teachers of various ages who were evidently endeavoring to renew their teaching certificates by taking this extension course in American Literature. The author gives many examples from the essay papers assigned showing flagrant misspelling, misuse of words, and a general inability to make understandable sentences.

Nearly all of these teachers instructed in English as one of their assigned subjects. So the author asks, "How illiterate can you be, and go on teaching in our public schools?" Yet in the end he admits, "I passed 'em. What would you have done?" Well, if they had shown some notable improvement, since they were already in the school system, I suppose I would have passed them, too; but with the lowest mark possible for most of them.

I wonder how many of you who teach the natural sciences or mathematics in college have noticed that when you have had a student who was notoriously weak in mathematics he almost in-

variably took his degree in the School of Education. Then, having landed a job in the public school system, have you noticed that his school principal, also trained in Education with a capital E, with the very first throw of the dice, chose him to teach mathematics? It is a case of the blind of one generation leading the blind of the next. This merely illustrates the evident contempt with which many of our school principals look upon the subject of mathematics. It sometimes seems as if they were saying, "Look how far I have come through politics, without any mathematics whatever."

If I had my way in the matter no student would ever graduate from college, whatever his field, without taking at least six semester hours of college mathematics, and doing it successfully besides.

Every normal school child should begin algebra in the fifth grade, and continue the subject every year along with arithmetic and under a competent teacher all the way through high school. Algebra is not a second rate subject. It is a major subject absolutely necessary to everyone who does analytical thinking, and an unflinching aid to anyone who even pretends to think. It must be considered fully the equal in importance with English, and even more universal. If people delude themselves into thinking that they can get along without algebra, it will be because they never intend to do any careful or intricate thinking.

As long as we allow these educational troglodytes to fix the standards of Elementary Education in our state, so that candidates for degrees in that field can obtain college diplomas and certification for teaching without ever having subjected themselves to a single hour of college mathematics, we are going to continue to turn out teachers of inferior training in mathematics; and the product that they in turn furnish us will continue to testify to the deadly efficiency of their subversive handiwork.

Why is our government vainly trying to fill countless positions with competent technicians? Why are candidates for West Point grossly deficient in their preparatory training? It is because we are no longer able to turn out enough competent graduates from our colleges to fill the jobs. It is because only a small number of our high school graduates have undergone the rigorous training necessary, and have developed the required courage, to attempt technological and scientific careers. Even our newer crop of Ph.D.'s are showing deficiency in elementary training, and they are likely

to get worse and worse as the years go by. Such a condition is intolerable, if we desire our civilization to survive.

A couple of years ago two of my physics students, who were rather proficient in mathematics, decided that they would like to teach mathematics in the Junior or Senior High School. So they visited one of the junior high schools just to see how well the job was being done. They were shown by the principal into a classroom where algebra was being taught, one where he considered a model of successful teaching was being exhibited; one where the young lady teacher was very popular with the students, being the product of a school of education. When one of the two visitors asked the teacher to see a copy of the textbook she was using, she most naively replied, "O I don't use the book, the problems in there are too hard. I make up easy ones for the students to do." Both of the young visitors saw the real heart of the situation at once. It wasn't the students who were afraid to meet the nextbook problems face to face, it was the teacher.

All of which reminds me of the advice once given me as an upperclassman in the university by one of my physics professors. "Becknell", said he, "if you ever decide to write a high school textbook that will sell, never write one that the teacher cannot understand. I once made that fatal mistake."

But, of course, there are many fine and sincere teachers in our school system who would be inspired to do more effective work, if they had more students who really desired to earn an education. Many of these are the older teachers who long ago had many students in whom they were deeply interested; the older teachers who knew English, arithmetic, history, and algebra, before Education with the capital E had replaced education with the small initial. However, these are the best teachers in the school system, who are forced to retire because of the age limit. Now, our educational wise men tell us that all will be well in a few years when the new style of teacher is put on the market. All will go smoothly under the New Dispensation, for then it will make no difference whether the student moves the decimal point to the right or to the left when he multiplies by ten. It will merely be a matter of convenience. In that halcyon day clerks will be trained who probably will measure off a yard and a half of cloth instead of a yard, or who will do as one of them did for me this summer, measure and cut off a small piece of carpet from a long roll, and

then instead of delivering to me the short piece will deliver the whole roll for the same price. These cute little tricks, of course, will be enjoyed by the dealer.

These older retiring teachers declare that they are glad to escape from this New Dispensation where so much of the teacher's time is wasted in filling out record sheets, answering questionnaires, and attending to absolutely ridiculous folderol, that there is little time left to do any drilling of pupils in the realm of thought.

Due to many causes our American system of free public education is today almost a total failure, a sobering catastrophe of major importance; unless, perhaps, we count our football scholars, our strutting majorettes, our well-drilled yelling teams, and our hot-rod technicians. The breakdown in education of our elementary school system, both public and private, begins with the date of incubation of some of our putty-headed teachers' colleges, whose soft approach to elementary education has been as deadly as though public enemies had torpedoed the foundations of our democracy. The effect has been to weaken the will of the younger generation to earn an education, when a high school diploma can just as well be obtained by "doing time" in one of our high schools. Within ten years, if the present rate of intellectual decay persists, it will be almost impossible to find suitably trained material for reliable clerks, physician's and dentist's technicians, engineers, scientists, physicians, and even college professors. I am frightened into the belief that we cannot soon improve upon the present Senate of the United States, where there are some blackmailers, and where many members have such questionable records that they can be blackmailed and made to do things that they know are wrong.

We are fast coming to the day when the Man of the Hour will be that finished product of our civilization, The Great American Moron. Wouldn't it be supposed that Nature has the capability to produce enough morons without asking for assistance from our educational experts?

By this time I have, in a very brief way, described the heavy stone wall which has been built squarely across our educational frontier, a wall which shuts out the light of day from millions of young minds that need nothing more than stern discipline in analytical studies and in general behavior to make them the saviors of American civilization.

Why is it that the United States has found it necessary to depend so heavily upon foreign trained physicists for her own survival. There is only one valid reason, and that is because we are not turning out enough thoroughly trained mathematicians and physicists ourselves to meet the needs of the nation, to say nothing of the engineers and other skilled technicians which are in demand. No half-baked variety is going to fill this need.

And who is the chief architect of this stone wall of obstruction? It is none other than Teachers' College, Columbia University, that has been building this monstrosity, stone upon stone, for the last half century, and which has hypnotized state after state into believing that it, and it alone, was the architect of a new day in American education. Well, perhaps, I should admit that it is a new day; but it is a day with the darkness of midnight.

In order to impress upon our young people the absolute necessity for their learning to the full every basic subject offered to them in the public schools stern discipline must be reintroduced into the school room as well as into each family in the nation. Juvenile delinquency is no accident. It is the result of carelessness in discipline both in the family and in school, especially during the early years. To impress upon young students the seriousness of elementary education, some of their present privileges should be removed.

First of all free public education should end with the completion of the Junior High School courses, for all those who have not thoroughly demonstrated by that time that they can profit fully by attending High School. The high school must be freed from litter. It is no place to entertain the idlers and the wiseacres who think they already know all that it is necessary to know. There should be two types of high school in each community, a classical high school and an industrial high school; but both of high quality with stiff requirements. The industrial high school must not be made the dumping ground for the lazy and the mischievous. If it is objected that many poor students must be kept in high school until they have reached the legal age to leave school, I would say that they should be sent back to the grades to make up the work they have disregarded, and not kept in the high school to make it a nightmare for the teachers as well as for the serious students. At present we are not giving our young men and young women of ability the attention that they deserve. The students who show

particular genius should be segregated from the ones of medium ability, and particularly from the idlers.

Furthermore, interscholastic games should be abolished as hindrances to real education, and replaced by an adequate system of physical education for all. The training of bands and orchestras undoubtedly is of great value, if it is not overdone to the point where high school students think that all school work should be play. Such major subjects as English, arithmetic, algebra, plane geometry, history, and foreign languages should get the principal attention during the school day.

Students of mine have told me that they hated mathematics in high school, so the teacher sent them to the blackboard to draw pictures during the arithmetic and algebra periods. Such a teacher deserves to be dismissed as a menace to education. Some students have told me that their principals would not allow them to study mathematics. Such a principal is not worthy of his position.

In America we need a great National Incentive, something that should be initiated by the government of the United States, an Educational Incentive as powerful as that of the Soviet Union, one that will blast the stone wall of obstruction from the pathway of technical education, and develop all the superior brains that the Nation can furnish. This can only be done by dethroning Education with a capital E, and replacing it with a thoroughly rational and exacting program, one that will leave no doubt in the student's mind that education is a serious process.

A LIST OF FISHES FROM THE SOUTHERN TIP OF
THE FLORIDA PENINSULA¹

JOHN D. KILBY and DAVID K. CALDWELL
University of Florida

The distribution of Florida fishes has not received sufficient attention to permit accurate delineation of the ranges for many species. One of the least known areas of the state is the southern tip, much of which is covered by the Everglades. This area is an extremely difficult one to collect, except under the fortuitous circumstances which we enjoyed during a recent field trip. A drought had concentrated the fishes in residual waters at a time when the noxious insects were not intolerable, permitting us to obtain a variety of fishes, some of which we took in satisfactory series. The specimens obtained have been deposited in the University of Florida Fish Collection.

We were reasonably satisfied that our collections, plus the several sight records, produced the majority of the strictly freshwater species to be expected. Such is not the case for the euryhaline fishes, but many of these are known as a result of published records from the Florida Keys. Thus this list is directed mainly to documenting the occurrence of those freshwater fishes which we found at the southern tip of the Florida peninsula.

The stations at which we collected were located in several of the major physiographic regions of south Florida as defined by Davis (1943), and we use his terminology below:

Everglades-Lake Okeechobee Basin: Stations 1 and 2.

Southern Coast and Islands:

Mangrove swamp present: Stations 11-17 and 19-24.

Mangrove swamp absent: Stations 3, 4, and 7-10.

Miami Rock Ridge: Stations 5 and 6.

Southwest Coast and Ten Thousand Islands: Station 18
(Narrow fringe of mangrove swamp bordering water-
course).

¹A contribution from the Florida State Museum and the Department of Biology, University of Florida.

Salinities, when stated to the nearest tenth of a ppt., were measured in the laboratory with a hydrometer. Several salinities were estimated in the field by taste. Those stations for which no salinity is indicated were considered to be strictly fresh water.

Bailey, Winn, and Smith (1954: 148-50) have treated the problem of subspecific designation of species considered polytypic by one or more recent authors. For the purposes of this paper we follow their example for most species.

Many of the stations visited were located within the Everglades National Park. Collecting in the Park was made possible by the kind permission of the superintendent, Mr. Dan Beard, whose staff extended to us many courtesies in the field.

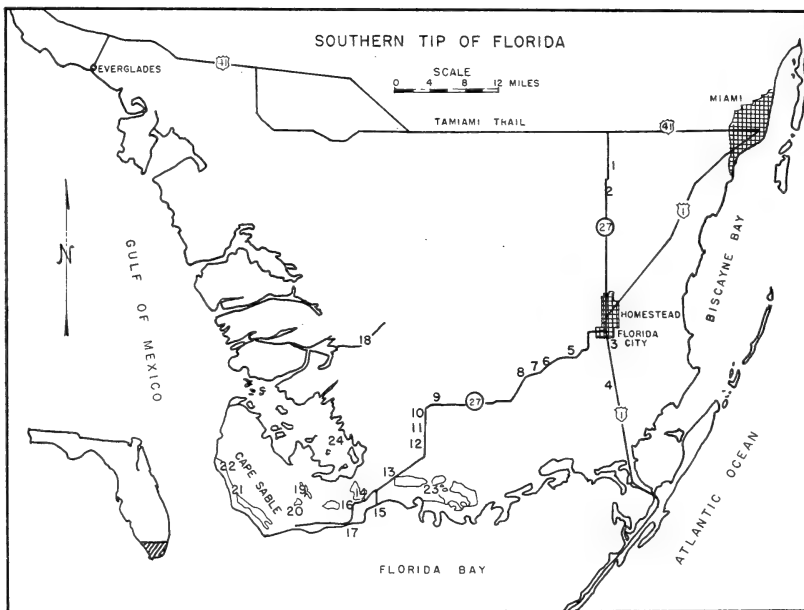

Figure 1. The approximate location of the collecting stations are shown by numbers corresponding to the numbered stations in the text.
(Map prepared by E. Coogle, staff artist.)

COLLECTING STATIONS

The species numbers enclosed in parentheses are, for various reasons, reliable sight records. All other species numbers listed are represented by specimens in the University of Florida Fish

Collection. The approximate locations of the stations are shown on Figure 1.

Station 1. Canal beside Florida highway 27, 17.6 miles north of Homestead, Dade Co., May 8, 1955, Kilby and Caldwell (field no. K-5-855-2). Water very turbid, greenish, very low; bottom mud and rock; *Ceratophyllum* abundant, patches of *Pontederia* and *Typha* along edges; depth to 4 feet, width 30 feet. Fish collected by cast net and seine. UF 5068-76.

Species: 2, (3), 9, 10, 15, 20, 21, 29, 31, 32.

Station 2. Canal beside Florida highway 27, 13.8 miles north of Homestead, Dade Co., May 8, 1955, Kilby and Caldwell (field no. K-5-855-1). Water very turbid, greenish, very low; bottom mud and rock; choked with *Najas*; depth to 4 feet, width 20 feet. Fish collected with seine. UF 5061-67.

Species: 2, 14, 20, 21, (28), 29, 30.

Station 3. Roadside ditch 1 mile south of Florida City on U. S. highway 1, Dade Co., May 7, 1955, Kilby and Caldwell (field no. K-5-755-1). Water clear, green, low; bottom limey mud; abundant *Najas*, *Cabomba*, and filamentous green algae, some unicellular green algae; depth to 6 feet, width 35 feet. Fish collected with cast net and traps. UF 5013-18.

Species: 2, 10, 28, 29, 30, 31, 32.

Station 3A. From the same ditch but about a mile south of Station 3, Mr. A. Newton made a collection on July 7, 1949. UF 211-13.

Species: 20, 21, 22.

Station 4. Canal beside U. S. highway 1, 8 miles south of Homestead, Dade Co., May 6, 1955, Kilby and Caldwell (field no. K-5-655-1). Water clear, colorless, low; rock bottom; sparse *Ruppia* and filamentous green algae along the edge; depth to 6 feet, width 50 feet. Fish collected with cast net, dip net, traps, and hook and line. UF 5001-07.

Species: (2), 14, 20, 21, 28, (29), 30, 31, 32.

Station 5. Borrow pit along Florida highway 27, approximately 2 miles west of Florida City, Dade Co., May 7, 1955, Kilby and Caldwell (field no. K-5-755-2). Water clear, colorless, very low; bottom white marl mud and rock; very sparse patches of *Chara*;

depth to 10 inches, width to 15 feet. Fish collected with seine. UF 5094-99.

Species: 13, 15, 18, 19, 20, 22.

Station 6. Borrow pit along Florida highway 27, 0.8 miles west of the main entrance to the Everglades National Park, Dade Co., May 7, 1955, Kilby and Caldwell (field no. K-5-755-13). Water clear, colorless, very low; bottom marl rock; sparse filamentous green algae; depth to 4 feet, width 75 feet. Fish collected with seines and traps. UF 5051-54.

Species: 20, 22, 29, 31.

Station 7. Canal and adjacent Taylor Slough (Anhinga Trail) along Florida highway 27, in the immediate vicinity of the Royal Palm Ranger Station, Everglades National Park, Dade Co.; bottom rock with mud in patches; abundant *Najas* and various emergent aquatic plants; depth to 4½ feet, width 5 to 25 feet.

7A. February 2 and 3, 1955, Caldwell. Water clear, colorless, level normal.

Species: (2), (3), (10), (20), (28), (29), (30), (32).

7B. May 7, 1955, Kilby and Caldwell (field no. K-5-755-14). Water clear, greenish, low. Fish collected with seines and traps. UF 5055-60.

Species: 2, 10, 15, 20, 21, 29.

Station 8. Canal beside Florida highway 27, 0.5 miles west of the Royal Palm Ranger Station, Everglades National Park, Dade Co., May 7, 1955, Kilby and Caldwell (field no. K-5-755-3). Water clear, greenish, low; bottom mud on rock; abundant *Najas* and filamentous green algae, some *Nelumbo*; depth to 3 feet, width 20 to 25 feet. Fish collected with cast net and traps. UF 5019-24.

Species: (2), 9, (10), (15), (20), (21), 28, 29, 30, 31, 32.

Station 9. At concrete bridge beside Florida highway 27 in canal 12.6 miles southwest of the Royal Palm Ranger Station, Everglades National Park, Dade Co., May 7, 1955, Kilby and Caldwell (field no. K-5-755-12). Water clear, colorless, low; bottom rock; very sparse *Najas*; depth to 2 feet, width 25 feet. Fish collected with seine. UF 5048-50.

Species: 2, 28, 30.

Station 10. Canal beside Florida highway 27, 15 miles southwest of the Royal Palm Ranger Station, Everglades National Park, Dade Co., May 7, 1955, Kilby and Caldwell (field no. K-5-755-4). Water clear, colorless, low; bottom lime mud and rock; abundant *Najas* and filamentous green algae; depth to 2 feet, width 20 feet. Fish collected with cast net and dip net. UF 5026-30.

Species: (2), 9, 15, 20, 21, (28), 30.

Station 11. Canal beside Florida highway 27, 16.5 miles southwest of the Royal Palm Ranger Station, Everglades National Park, Dade Co., May 7, 1955, Kilby and Caldwell (field no. K-5-755-5). Water very turbid, green, low; salinity 2.4 ppt.; bottom mud on rock; abundant *Najas* and filamentous algae; depth to 5 feet, width 30 feet. Water very stagnant, numbers of dead fish floating.

Species: (2), (4), (13), (20), (21), (22), (29), (30).

Station 12. Canal beside Florida highway 27, 17.4 miles southwest of the Royal Palm Ranger Station, Everglades National Park (at Whiskey Creek), Dade Co., May 7, 1955, Kilby and Caldwell (field no. K-5-755-6). Water moderately turbid, brownish, low; salinity 22.2 ppt.; red mangrove (*Rhizophora*) along the edge, some filamentous green algae; depth to 6 feet, width 10 to 30 feet. Fish collected with dip net. UF 5031-32.

Species: (2), (4), 16, 20, 21, 22, (29).

Station 13. Boat landing on north side of West Lake Pond along Florida highway 27, 23 miles southwest of the Royal Palm Ranger Station, Everglades National Park, Dade Co., May 7, 1955, Kilby and Caldwell (field no. K-5-755-7). Water very turbid, milky, low; salinity 7.0 ppt.; no vegetation; depth to 2 feet. Fish collected with seine. UF 5033-37.

Species: 16, 19, 20, 22, (25), 37.

Station 14. Boat landing on south side of Coot Bay Pond at the Coot Bay Ranger Station, Everglades National Park, Monroe Co. Bottom rock fill; no vegetation; depth to 4 feet.

14A. February 1, 1955, Caldwell. Water very turbid, milky, level normal. Salinity not taken.

Species: (20).

14B. May 7, 1955, Kilby and Caldwell (field no. K-5-755-10). Water very turbid, greenish, level normal; salinity 21.0 ppt. Fish collected with seine. UF 5042-47.

Species: 5, 7, 22, 23, 26, 27, 37.

Station 15. Florida Bay at end of Snake Bight canal, Everglades National Park, Monroe Co., May 7, 1955, Kilby and Caldwell (field no. K-5-755-11). Water very turbid, milky, high tide; salinity estimated by taste to exceed 25 ppt.; bottom lime mud; no vegetation; depth to 2 feet. Fish collected with seines. UF 5088-93.

Species: 11, 12, 16, 19, 22, 26.

Station 16. East end of Homestead canal near the Coot Bay Ranger Station, Everglades National Park, Monroe Co. Bottom mud; no vegetation; depth to 3 feet, width 25 feet.

16A. January 23 and 24, 1955, Caldwell. Water fairly turbid, brownish, level normal. Salinity not taken.

Species: (1), (2), (20), (25).

16B. May 7, 1955, Kilby and Caldwell (field no. K-5-755-8). Water fairly turbid, greenish-brown, level normal; salinity 41.1 ppt. Fish collected with cast net. UF 5038.

Species: 4.

Station 17. Florida Bay at Flamingo, Everglades National Park, Monroe Co. Bottom mud and sand.

17A. April 19, 1954, Caldwell and Leonard Giovannoli (field no. C-4-1954-1). Water turbid, colorless; low tide (rising); salinity 39.3 ppt.; depth 5 feet; approximately 1 mile from shore; sparse shoal grass (*Halodule*) and turtle grass (*Thalassia*). Fish collected hook and line. UF 5156-57.

Species: 6, 35.

17B. May 7, 1955, Kilby and Caldwell (field no. K-5-755-9). Water very turbid, milky brown; high tide; salinity 42.1 ppt.; depth to 3 feet; along shore; no vegetation. Fish collected with cast net and seine. UF 5039-41.

Species: 7, 36, 37.

Station 18. Junction of Avocado Creek and Rookery Branch at Little Banana Patch (headwaters of Shark River), Everglades Na-

tional Park, Monroe Co., January 28, 1955, Caldwell, Noble Enge, Nathan Moskowitz, Dale W. Rice, and Gerald Simon (field no. C-1-2855-1). Water clear, colorless, level normal; moderate current; bottom mud, marl, peat, and detritus; abundant *Najas*, some *Cabomba* and filamentous green algae; depth to 6 feet. Though this creek is fed by runoff from the Everglades proper, it has a marked resemblance to the run of a typical large Florida spring. Fish collected with hook and line and dip net. UF 4459-62.

Species: (2), (9), (15), 20, (25), 28, 29, 30, (32).

Station 19. Southeast shore of Middle Fox Lake, Everglades National Park, Monroe Co., January 24, 1955, Caldwell, Enge, Moskowitz, Rice, and Simon (field no. C-1-2455-1). Water clear, colorless, level normal; brackish by taste; bottom mud, marl, and detritus; no vegetation; depth less than 1 foot. Fish found in a submerged hollow log. UF 4463.

Species: 38.

Station 20. Southeast shore of Gator Lake, Everglades National Park, Monroe Co., January 24, 1955, Caldwell, Enge, Moskowitz, Rice, and Simon (field no. C-1-2455-2). Water fairly turbid, colorless, level normal; brackish by taste; bottom mud, marl, and detritus; red mangrove (*Rhizophora*) prop roots; depth 1 foot. Fish collected with dip net. UF 4464.

Species: 20.

Station 21. Southeastern end of Little Sable Creek near its junction with Lake Ingraham, Everglades National Park, Monroe Co., January 26, 1955, Caldwell and Enge. Water turbid, colorless, low tide; salinity estimated by taste to exceed 25 ppt.; bottom black mud; no vegetation; depth 1 foot, width 25 feet. Fish collected by flipping it onto the bank with a canoe paddle.

Species: (33).

Station 22. Northeastern portion of Little Sable Creek, Everglade National Park, Monroe Co., January 26, 1955, Caldwell, Enge, Moskowitz, Rice, and Simon. Water turbid, colorless, mid tide; salinity estimated by taste to exceed 25 ppt.; bottom black mud; no vegetation; depth to 3 feet, width 30 feet.

Species: (1), (2), (4), (20), (23), (25).

Station 23. Streams connecting West Lake and Long Lake and connecting Long Lake and Cuthbert Lake, Everglades National Park, Dade Co., February 2, 1955, Caldwell. Water fairly turbid, colorless; level normal; salinity estimated by taste to exceed 25 ppt.; bottom mud; no vegetation except red mangrove (*Rhizophora*) roots; depth 1 foot.

Species: (2), (20).

Station 24. Whitewater Bay about midway down eastern side on a spit of land, Everglades National Park, Monroe Co., February 1, 1955, Caldwell (field no. C-2-155-1). Water clear, colorless, level normal; salinity estimated by taste to exceed 25 ppt.; bottom marl and sand; very sparse green algae, red mangrove (*Rhizophora*) roots; depth to 3 feet. Fish collected with dip net. UF 4465.

Species: 27, (34).

LIST OF SPECIES

The station numbers in parentheses indicate that the species was observed but not collected.

SHARKS

1. *Sharks*

Though none were definitely seen or collected, evidences seen by one of us (DKC) at stations (16A), (22), and in the Little Shark River near Tarpon Bay (just southwest of Station 18), and statements by park rangers, indicate that sharks occur in enclosed waters in the southwest tip of the peninsula.

LEPISOSTEIDAE—Gars

2. *Lepisosteus platyrhincus* DeKay. Florida spotted gar

This is undoubtedly the most abundant large fish in the freshwaters of the area studied.

Stations: 1, 2, 3, (4), (7A), 7B, (8), 9, (10), (11), (12), (16A), (18), (22), (23).

AMIIDAE—Bowfins

3. *Amia calva* Linnaeus. Bowfins; Mudfish

Stations: (1), (7A).

MEGALOPIDAE—Tarpons

4. *Tarpon atlanticus* (Valenciennes). Tarpon
Stations: (11), (12), 16B, (22).

ELOPIDAE—Ten Pounders

5. *Elops saurus* Linnaeus. Ten pounder; Ladyfish
Station: 14B.

CLUPEIDAE—Herrings

6. *Harengula pensacolatae pensacolatae* Goode and Bean. Pilchard
Station: 17A.

ENGRAULIDAE—Anchovies

7. *Anchoa mitchilli* (Valenciennes). Bay anchovy
Stations: 14B, 17B.

CATOSTOMIDAE—Suckers

8. *Erimyzon sucetta* (Lacépède). Lake chubsucker; Eastern chub-sucker

A single specimen (UF 458) of this species is in the University of Florida Fish Collection labeled "open limestone cave between Coomes and Florida City, Dade Co., (vicinity of Station 3), collected on December 17, 1930, by M. K. Brady".

CYPRINIDAE—Minnows

9. *Notemigonus crysoleucas* (Mitchill). Golden shiner
Stations: 1, 8, 10, (18).

ICTALURIDAE—Catfishes

10. *Ictalurus natalis* (LeSueur). Yellow bullhead
Stations: 1, 3, (7A), 7B, (8).

CYPRINODONTIDAE—Killifishes

11. *Fundulus grandis* Baird and Girard. Killifish
Station: 15.
12. *Fundulus similis* (Baird and Girard). Long-nosed killifish
Station: 15.

13. *Fundulus confluentus* Goode and Bean. Spottfin killifish
Stations: 5, (11).
14. *Fundulus chrysotus* Holbrook. Golden topminnow
Stations: 2, 4.
15. *Lucania goodei* Jordan. Red-finned killifish
Stations: 1, 2, 5, 7B, (8), 10, (18).
16. *Lucania parva* (Baird and Girard). Rainwater killifish
Stations: 12, 13, 15.
17. *Adinia xenica* (Jordan and Gilbert). Diamond killifish
Reported from the stomachs of the Wood Ibis, *Mycteria americana*, from Alligator Lake (vicinity of Station 20) by Howell (1932: 115) as *A. multifasciata*.
18. *Jordanella floridae* Goode and Bean. Flagfish
Station: 5.
19. *Cyprinodon variegatus* Lacépède. Sheepshead killifish
Reported by Howell (*loc. cit.*) from Alligator Lake (vicinity of Station 20).
Stations: 5, 13, 15.

POECILIIDAE—Livebearers

20. *Gambusia affinis* (Baird and Girard). *Gambusia*
Reported by Howell (*loc. cit.*) from Alligator Lake (vicinity of Station 20). Mr. Luis R. Rivas of the University of Miami has a *Gambusia* from brackish waters of southern Florida which is in the process of description (personal communication). Quite possibly some of our specimens, especially those from the brackish water stations, represent the new form.
Stations: 1, 2, 3A, 4, 5, 6, (7A), 7B, (8), 10, (11), 12, 13, (14A), (16A), 18, 20, (22), (23).
21. *Heterandria formosa* Agassiz. Least killifish
Stations: 1, 2, 3A, 4, 7B, (8), 10, (11), 12.
22. *Mollienesia latipinna* LeSueur. Sailfin molly
Reported by Howell (*loc. cit.*) from Alligator Lake (vicinity of Station 20).
Stations: 3A, 5, 6, (11), 12, 13, 14B, 15.

BELONIDAE—Needlefishes

23. *Strongylura* sp.

We have juvenile specimens from Station 14B which we are unable to place specifically. Sight records of adults from Station (22) are also included here for like reason.

APHREDODERIDAE—Pirate-perches

24. *Aphredoderus sayanus* (Gilliams). Pirate-perch

There is a single specimen (UF 541) in the University of Florida Fish Collection labeled "open limestone cave between Coomes and Florida City, Dade Co., (vicinity of Station 3), collected on December 17, 1930, by M. K. Brady".

MUGILIDAE—Mulletts

25. *Mugil cephalus* Linnaeus. Striped mullet

Stations: (13), (16A), (18), (22).

26. *Mugil curema* Cuvier and Valenciennes. White mullet

Stations: 14B, 15.

ATHERINIDAE—Silversides

27. *Menidia beryllina* (Cope). Tidewater silverside

Stations: 14B, 24.

CENTRARCHIDAE—Sunfishes

28. *Micropterus salmoides floridanus* (LeSueur). Florida large-mouth bass

Stations: (2), 3, 4, (7A), 8, 9, (10), 18.

29. *Chaenobryttus coronarius* (Bartram). Warmouth

This appears to be the most abundant Centrarchid in the area. Stations: 1, 2, 3, (4), 6, (7A), 7B, 8, (11), (12), 18.

30. *Lepomis punctatus* (Valenciennes). Stumpknocker; Spotted sunfish

Apparently the most abundant *Lepomis* in this region. Stations: 2, 3, 4, (7A), 8, 9, 10, (11), 18.

31. *Lepomis microlophus* (Günther). Shellcracker; Redear sunfish

This species was reported from Alligator Lake (vicinity of Station 20) by Howell (*loc. cit.*) as *L. holbrookii*.

Stations: 1, 3, 4, 6, 8.

32. *Lepomis macrochirus* Rafinesque. Bluegill
 Stations: 1, 3, 4, (7A), 8, (18).

SERRANIDAE—Sea Basses

33. *Mycteroperca microlepis* (Goode and Bean). Gag
 Station: (21).

LUTJANIDAE—Snappers

34. *Lutjanus griseus* (Linnaeus). Gray snapper; Mangrove snapper
 Station: (24)

SPARIDAE—Porgies

35. *Lagodon rhomboides* (Linnaeus). Pinfish
 Station: 17A.

LEIOGNATHIDAE—Moharras

36. *Eucinostomus gula* (Cuvier and Valenciennes). Common moharra
 Station: 17B.
37. *Eucinostomus argenteus* Baird and Girard. Spotfin moharra
 Stations: 13, 14B, 17B.

BATRACHOIDIDAE—Toadfishes

38. *Opsanus beta* Goode and Bean. Toadfish
 Station: 19.

LITERATURE CITED

- BAILEY, REEVE M., HOWARD ELLIOTT WINN, and C. LAVETT SMITH
 1954. Fishes from the Escambia River, Alabama and Florida, with ecologic
 and taxonomic notes. *Proc. Acad. Nat. Sci. Phil.*, CVI: 109-164.
- DAVIS, JOHN H., JR.
 1943. The natural features of southern Florida. *Fla. Geol. Surv., Geol.
 Bull. No. 25*, pp. 1-311.
- HOWELL, ARTHUR H.
 1932. Florida Bird Life. Florida Dept. of Game and Fresh Water Fish
 in cooperation with Bureau of Biological Survey, U.S.D.A., i-xxiv,
 1-579, 58 pls., 72 figs.

METACHROSIS IN SNAKES ¹

WILFRED T. NEILL and E. ROSS ALLEN

Research Division, Ross Allen Reptile Institute, Silver Springs, Fla.

Little seems to be known about metachrosis in snakes; indeed, its very existence in this group has sometimes been denied. The pertinent literature is scanty and contradictory. Schmidt and Davis (1941) declared, "Snakes are unable to change color as many lizards can." However, Klauber (1931) had previously mentioned that the sidewinder, *Crotalus cerastes*, and the Pacific rattlesnake, *C. viridis oreganus*, were capable of changing color. Klauber (1939) had also stated, ". . . snakes . . . have little or no power of color change; in fact, there are those who say that no snake has any such power, although I am certain that it is evident to a slight degree in some species of *Crotalus*." Kauffeld (1943) denied the contentions of Klauber, suggesting that the latter had observed only a slow and progressive lightening of color in captive specimens. Klauber (1944) subsequently remarked, "There seems little doubt that the colors of live sidewinders are somewhat affected by temperature in the manner so much more evident in lizards." Neill (1951) described relatively rapid and marked color change in a sidewinder, thus verifying Klauber's findings.

Rahn (1941), in a study of the prairie rattlesnake, *Crotalus v. viridis*, found that a dark pattern, superimposed on a yellowish-white background, was produced by three types of melanophores, all of which could disperse or concentrate their melanin pigment. Such dispersion or concentration was dependent upon the presence or absence of the pars intermedia hormone of the pituitary gland, and when this organ was removed, the reptiles permanently assumed a cream color as the result of complete pigment concentration in the melanophores. In a later study of the prairie rattlesnake, Rahn (1942) reported that exposure to high temperatures produced a light coloration just as did hypophysectomy, and that low temperatures resulted in considerable darkening through melanin dispersion. Although Rahn did not so comment, his experimental temperatures were no higher or lower than those apt to be encountered by snakes in nature.

¹Presented before the 34th Annual Meeting of the American Society of Ichthyologists and Herpetologists, University of Florida, September 8, 1954.

In spite of the papers cited above, Werler and Smith (1952) stated, ". . . color change in lizards may be a response to . . . light, heat, excitement or death, but there is no information to indicate that the same factors will elicit a similar response in snakes." Werler and Smith then noted that the light bands of a captive cat-eyed snake, *Leptodeira mystacina*, became lighter and "opaque" during the night, and that a somewhat similar change had been observed by Robert Snedigar in captive reticulated pythons, *Python reticulatus*.

In the present paper we wish to emphasize that some snakes can and do change color under natural conditions, apparently as a result of temperature fluctuations.

At the Reptile Institute, eastern diamondback rattlesnakes, *Crotalus adamanteus*, are kept in an outside enclosure. This pen is roofed over to shield the reptiles from the hot summer sun, and is surrounded by a moat of running water to prevent them from freezing during the colder days of winter; but otherwise the captive rattlesnakes are exposed to local temperature conditions. Usually there is a good bit of individual color variation among these snakes (which are from widely scattered localities). The ground color may be whitish in one specimen, yellow in another, olive in a third; and the dark pattern may be much more intense in some examples than in others. Should the weather turn cold, however, overnight all the rattlesnakes become very dark, and no individual color variation is evident early the following morning.

Frequently, on cold mornings, several diamondbacks chance to be coiled in a shaft of direct sunlight, and these specimens will be noticeably lighter than those still resting in the shade. The lighter coloration of the basking individuals is definitely not an optical illusion produced by variation in illumination.

On one occasion a large number of western diamondback rattlesnakes, *Crotalus atrox*, were collected in Webb County, Texas. Some of the specimens were unusually colored, displaying a silvery-white or a golden-yellow ground color. After overnight exposure to low temperatures, however, all the snakes had become relatively dark, and no individual color differences could be detected.

These observations were casual ones, and there was an obvious need for experimentation under controlled laboratory conditions. Accordingly, studies were made of metachrosis in a captive adult sidewinder, *Crotalus cerastes laterorepens*. Thirteen areas of the

snake's body were examined and their color noted. These areas were as follows: (1) right postorbital stripe midway of its length, scale tip; (2) right postorbital stripe midway of its length, scale base; (3) last dark tail ring at dorsal midline; (4) light tail ring preceding last dark one, at dorsal midline; (5) first dark tail blotch posterior to level of vent, at midline; (6) center of third blotch on body, at midline (all body blotches counted forward from the level of the vent); (7) posterior dark border of third blotch on body, at midline; (8) ground color of dorsum between the third and fourth dorsal blotches; (9) proximal lobe of rattle-matrix; (10) ground color of side at a level midway between the ninth and tenth dorsal blotches; (11) side of snout midway between gape and post-ocular dark stripe; (12) small spot in parietal region, one of many such spots on the head; (13) midline of venter, near midbody. For convenience these areas will be referred to hereafter by number. Parenthesized color names and notations are from Maerz and Paul (1950).

With the snake's cloacal temperature at 31° C., the various areas of the body were colored as follows: (1) yellowish-cream (9 G 2); (2) medium brown (14 D 11); (3) black; (4) whitish; (5) light brownish (12 D 7, bran); (6) light brownish (12 D 7, bran); (7) inconspicuously gray- and black-stippled; (8) light flesh color (a little lighter than 9 B 2, polar bear); (9) black; (10) tannish-beige (11 B 3, champagne) with faint gray stippling; (11) very light flesh color (a little lighter than 11 A 2, flesh); (12) light brownish (12 E 8); (13) white. The color notations were made indoors at a window, under direct sunlight on a winter morning.

The snake's temperature, as determined cloacally by a mercury thermometer, was then lowered. This was accomplished by placing the snake, cage and all, out of doors in fairly bright but not direct sunlight, and allowing it to remain there for four hours. At the end of this time the snake's cloacal temperature was approximately 8° C. Color notations were then made out of doors in direct sunlight. Several areas of the reptile's body had altered in appearance. (1) had become duller yellow (11 G 3); (2) was a darker brown (15 E 11, new bronze); (4) had a faint buffy cast (a little lighter than 12 A 2, moonmist); (6) seemed a slightly duller brown (13 D 6, cracker); (7) had become more intensely stippled with dark gray and black; (8) had darkened slightly (11 B 2, putty); (10) was more conspicuously stippled; (11) had become so heavily gray-stippled

as to obscure most of the previously recorded color; (12) had not perceptibly altered, yet appeared much less distinct owing to a slight darkening of the ground color of the head.

The snake was then brought into a heated room and allowed to remain there, in direct sunlight near a window, for two hours. At the end of this time its cloacal temperature was about 35° C. Color notations were made in direct sunlight. Several areas of the body had lightened. (2) had become a somewhat lighter brown than ever (13 D 7, oakbuff); (4) was again whitish; (5) was light brownish (12 B 5, fallow); (6) was light brownish (12 B 4, Long Beach); (7) again showed but inconspicuous stippling; (8) had returned to light flesh color (a little lighter than 9 B 2, polar bear); (10) was but faintly stippled; (12) was again in sharp contrast with the head. However, (1) was slow to lighten, and (11) remained for a time rather heavily stippled. Throughout the experiment, areas (3), (5), (9), and (13) were not observed to alter in coloration.

It is not contended that all of the apparent color changes were significant. The precise matching of colors may be hampered by several factors, particularly by diversity of surface textures. It is especially difficult to compare small areas of a living reptile with the plates of a color chart and achieve absolutely accurate results. The same color might conceivably be recorded as, say, (11 B 4) on one occasion and (11 D 3) on another, the apparent difference arising from variation in the environment or in the observer rather than in the color itself. Nevertheless, some of the recorded color changes in this case were too great to be explained away in any such fashion.

Metachrosis in the present specimen might be summarized as follows: At the beginning of the experiment, under a warm temperature, the scales of the postorbital stripe were brownish except for yellowish tips. Upon exposure to cold, the brown became darker through the development of a minute but dense stippling, and the brown areas encroached upon the yellowish scale tips which themselves seemed to darken. The brownish dorsal body blotches were edged with a grayish-black stippling which intensified when the reptile was chilled; and the actual blotches appeared to darken slightly. At warmer temperatures, the side of the snout, between the postorbital stripe and the gape, appeared almost white on gross inspection; faint grayish stippling was present but evident only on close examination. Under the influence of cold, the stip-

pling intensified to a marked degree. The lateral ground color of the body also became more heavily stippled at lower temperatures. The whitish interspaces between the dorsal blotches seemed to darken slightly in the cold-induced phase, but they did not darken as markedly as did the areas bordering them. Consequently, the interspaces stood out rather sharply, like a row of small, light spots, when the snake was cold, and were much less conspicuous when it was warm. The brownish spots of the head did not alter with temperature, but in the cold-induced phase they contrasted less strongly with the ground color of the head. The whitish tail rings seemed to darken very slightly under the influence of cold. No one area of the body changed color to a really pronounced degree, but the small changes of value were sufficient to alter the snake's general appearance considerably.

A color sensation is generally considered to have three attributes, sometimes called hue, value, and saturation. In the sidewinder, value was the only one of these attributes to vary with temperature. In other words, the observed metachrosis involved only a darkening or a lightening, presumably resulting solely from expansion or contraction of melanophores.

Metachrosis in the above-mentioned specimen was far less pronounced than in the one previously reported on by Neill (*op. cit.*). However, the former was a *Crotalus cerastes laterorepens* with a dull buffy ground color and dull brownish blotches, while the latter was a very light *C. c. cerastes* with shades of cream, orange, and pink in the pattern. Expansion of melanophores would probably be more impressive, visually, in very light specimens.

Habits, habitat, and temperature tolerances of *Crotalus cerastes* have been discussed by Cowles and Bogert (1944) and by Klauber (1939). Sidewinders are inhabitants of certain western desert areas. In portions of the species' range, summer air temperatures may rise to 55° C., while winter nights may be freezing. During a 24-hour period the temperature may vary as much as 30° C. Although primarily nocturnal, sidewinders are sometimes found abroad in daylight, particularly during early spring and late fall, or in the early morning hours. They are occasionally active in quite cold weather, and have been noted on desert roads at night when the cold wind was so strong as literally to sweep them across the smooth highway. Their spring season of activity is as early as that of any snake found within their desert range, and they are

among the last snakes to go into hibernation in the fall. On the other hand, they are occasionally found coiled and fully exposed to the midsummer sun. Nevertheless, under captive conditions approximating those of their normal habitats, sidewinders were noteworthy for their ability to maintain a constant body temperature within the narrow limits of 31-32° C. From these observations, it might be suspected that metachrosis in the sidewinder is of considerable importance as a thermoregulatory mechanism, permitting longer periods of activity both daily and seasonally.

Klauber (1939) stated that sidewinders tend to match the hues of the sand on which they dwell. This circumstance may have arisen through natural selection; but conceivably, metachrosis might be involved. Clearly there is a need for intensive field study of this interesting reptile.

Rahn (1941) found that hypophysectomy, and concomitant concentration of melanin in the melanophores, resulted in paling, not only in the prairie rattlesnake, but in two species of garter snakes, genus *Thamnophis*; in the bull snake, *Pituophis melanoleucus sayi*; and in the Florida banded water snake, *Natrix sipedon pictiventris*. In all these reptiles, the pigmentary effects of hypophysectomy could then be largely neutralized by the injection of intermedin. Evidently, in various colubrid snakes as well as *Crotalus*, there is a pituitary regulation of melanophores; and one might suspect that this physiological mechanism is not completely useless to the species involved, even though its precise function is not known at present.

Although there are few published accounts of metachrosis in snakes, several herpetologists have witnessed this phenomenon and have kindly permitted us to mention their observations. Among colubrids, the glossy snake, *Arizona elegans*, is capable of changing color. This fact was brought to our attention by Charles M. Bogert. Dr. Bogert stated that specimens collected by him darkened considerably overnight, probably as a result of the lowered temperatures that prevailed after sunset. Cowles and Bogert (*op. cit.*) found that the glossy snake was exposed in nature to wide fluctuations of temperature; and, like the sidewinder, seemed markedly tolerant of cold. Howard Campbell stated that a juvenile Great Plains rat snake, *Elaphe guttata emoryi*, collected by him in a desert situation of Mexico, seemed capable of metachrosis; at times it appeared reddish, at other times dull brownish. L. Neil Bell in-

formed us that the eastern hog-nose snake, *Heterodon platyrhinos*, had been observed to darken under the influence of cold.

William E. Duellman called our attention to metachrosis in a Mexican boa, *Constrictor constrictor imperator*, which darkened most noticeably when chilled. This boa was in the possession of Arthur E. Damman, who generously permitted us to keep it for several days, and to observe the way its coloration varied with temperature. The snake was a very light example of its kind, at least at summer room temperatures, being marked with shades of pinkish and fawn; this circumstance may explain why its metachrosis was so impressive visually. Most Mexican boas are dark, being patterned with blackish, chestnut, and wood brown. Metachrosis in such dark snakes might be overlooked, or dismissed as an optical illusion resulting from variations in lighting. L. Neil Bell has also observed that some boas of this species become much darker when cold.

Metachrosis seems to be much more widespread among snakes than is generally realized, some sort of color change having been noted in crotalid, colubrid, and boid species. In *Crotalus* and probably in *Arizona* and *Elaphe guttata emoryi*, metachrosis may function chiefly as an aid to thermoregulation, permitting longer periods of activity. As for the common hog-nose snake, it has been described as "the last reptile to go into hibernation" in Georgia; young of the year have been found foraging as late as November and December (Neill, 1948). Metachromatic thermoregulation might therefore be quite useful to the species. The Mexican boa ranges from northern South America northward almost to the United States border in Sonora, Mexico; in the northern part of its range, at least, it is exposed to extremes of temperature and so might profit by a thermoregulatory mechanism. According to Werler and Smith (*op. cit.*), the light crossbands of *Leptodeira mystacina* became decidedly lighter at night although there were but negligible temperature fluctuations, and so another explanation must be advanced for color change in this species. An hypothesis may be offered. By day the pattern of this rear-fanged snake affords a remarkable example of disruptive coloration through constructive shading. However, in the absence of metachrosis the light (grayish) bands would not especially contrast with the dark ones by night, when the snake is most active. Actually, the light bands become paler by night and so continue to maintain somewhat the same degree

of contrast with the dark ones, thus breaking up the snake's outline and helping to conceal the reptile from keen-eyed nocturnal predators or from potential prey. A similar situation might exist with *Python reticulatus*, which is elaborately camouflaged and largely nocturnal.

The slow and progressive lightening of captive snakes, mentioned by Kauffeld (*op. cit.*), might be explained as loss of "suntan." Nothing much seems to have been recorded about "tanning" in reptiles. We have previously mentioned its occurrence in alligators (Allen and Neill, in press). At any rate, this type of color change is not metachrosis and need not be discussed here.

The pituitary regulation of melanophores, reported in *Thamnophis*, *Natrix*, and *Pituophis*, might function on a seasonal basis, darkening the snakes as winter approaches. In this connection, the senior author is under the purely subjective impression that several common colubrid snakes are apt to be unusually dark when unearthed from shallow hibernating sites in cold weather.

Metachromatic responses in snakes appear to be somewhat unpredictable; they may be affected by visual stimuli or other factors, as well as by temperature. This, however, remains to be demonstrated. At any rate, the subject of metachrosis in snakes merits much further study, from the standpoints of physiology, ecology, and animal behavior.

LITERATURE CITED

ALLEN, E. ROSS, and WILFRED T. NEILL

In press. Some Color Abnormalities in Crocodylians. *Copeia*.

COWLES, R. B., and C. M. BOGERT

1944. A Preliminary Study of the Thermal Requirements of Desert Reptiles. *Bulletin of the American Museum of Natural History*. Vol. 83, Art. 5.

KAUFFELD, CARL F.

1943. Field Notes on Some Arizona Reptiles and Amphibians. *The American Midland Naturalist*. Vol. 29, No. 2, pp. 342-359.

KLAUBER, L. M.

1931. A Statistical Survey of the Snakes of the Southern Border of California. *Bulletins of the Zoological Society of San Diego*, No. 8.

1939. Studies of Reptile Life in the Arid Southwest. *Ibid.*, No. 14.

1944. The Sidewinder, *Crotalus cerastes*, with Description of a New Subspecies. *Transactions of the San Diego Society of Natural History*, Vol. 10, No. 8, pp. 91-126.

MAERZ, A., and M. R. PAUL

1950. Dictionary of Color. Second edition. McGraw-Hill Book Co.

NEILL, WILFRED T.

1948. Hibernation of Amphibians and Reptiles in Richmond County, Georgia. *Herpetologica*, Vol. 4, Part 3, pp. 107-114.

1951. Notes on the Natural History of Certain North American Snakes. Publications of the Research Division, Ross Allen's Reptile Institute, Vol. 1, No. 5.

RAHN, HERMANN

1941. The Pituitary Regulation of Melanophores in the Rattlesnake. *Biological Bulletin*, Vol. 80, No. 2, pp. 228-237.

1942. Effect of Temperature on Color Change in the Rattlesnake. *Copeia* No. 3, p. 178.

SCHMIDT, K. P., and D. D. DAVIS

1941. Field Book of Snakes of the United States and Canada. G. P. Putnam's Sons.

WERLER, J. E., and H. M. SMITH

1952. Notes on a Collection of Reptiles and Amphibians from Mexico, 1951-1952. *The Texas Journal of Science*, No. 4, pp. 551-573.

A BIOLOGICAL SOIL TEST FOR AVAILABLE PHOSPHORUS BY SPONTANEOUS GROWTH OF SOIL ORGANISMS

JAMES P. FLAVIN and SETON N. EDSON
University of Florida

The search for a simple and more rapid biological technique to aid in determining available nutrients in the soil has been a desirable problem of long standing. Winogradsky (1925), using the *Azotobacter* soil-plaque technique, observed a close correlation between certain limiting factors for *Azotobacter* and those for growing plants. In 1927, he suggested that the responses of these microbes to calcium, phosphorus, and potassium could serve to indicate the limiting factors for these minerals with closer correlation to available amounts than may be achieved by chemical methods. Various ramifications of his basic technique followed (Sackett and Stewart, 1931; Halversen and Hodge, 1932). Results of these techniques as compared with Neubauer's seedling method (1923) showed both good and fair correlation (Stewart, *et al.*, 1931; Dahlberg and Brown, 1932; Green, 1932).

Another method which emanated from the earlier works of Butkewitsch (1909) in Russia was the *Aspergillus niger* technique. Through the efforts of Niklas, *et al.* (1930), and Niklas and Poschenreider (1936), there evolved a qualitative and quantitative method for the determination of available phosphorus, potassium, and to some extent, magnesium. Following this, Melich, *et al.* (1934), having modified Nicklas' method (1933), developed the *Cunninghamella*-plaque method for quantitative determinations of available phosphorus in soils. Comparisons between this latter method, the *Aspergillus niger* method, chemical methods, and field trials revealed good agreement with field test results.

It is to be noted that in all of the above cited references the techniques developed have utilized only isolated, specific cultures of soil organisms. However, those who are familiar with microbiology are well aware of the problems and the effort required to maintain aseptic techniques, as well as the storage of pure cultures. In the soil there exist not only the kinds of organisms used in these techniques mentioned, but countless numbers of other bacteria and fungi which are all classified as lower forms of plant life. They,

too, require phosphorus in varying amounts. The possibility exists that the combined numbers of spontaneous microbial growth in a relatively large sample of soil (one-half pound), when supplied with varying quantities of phosphorus (other nutrients being constant),

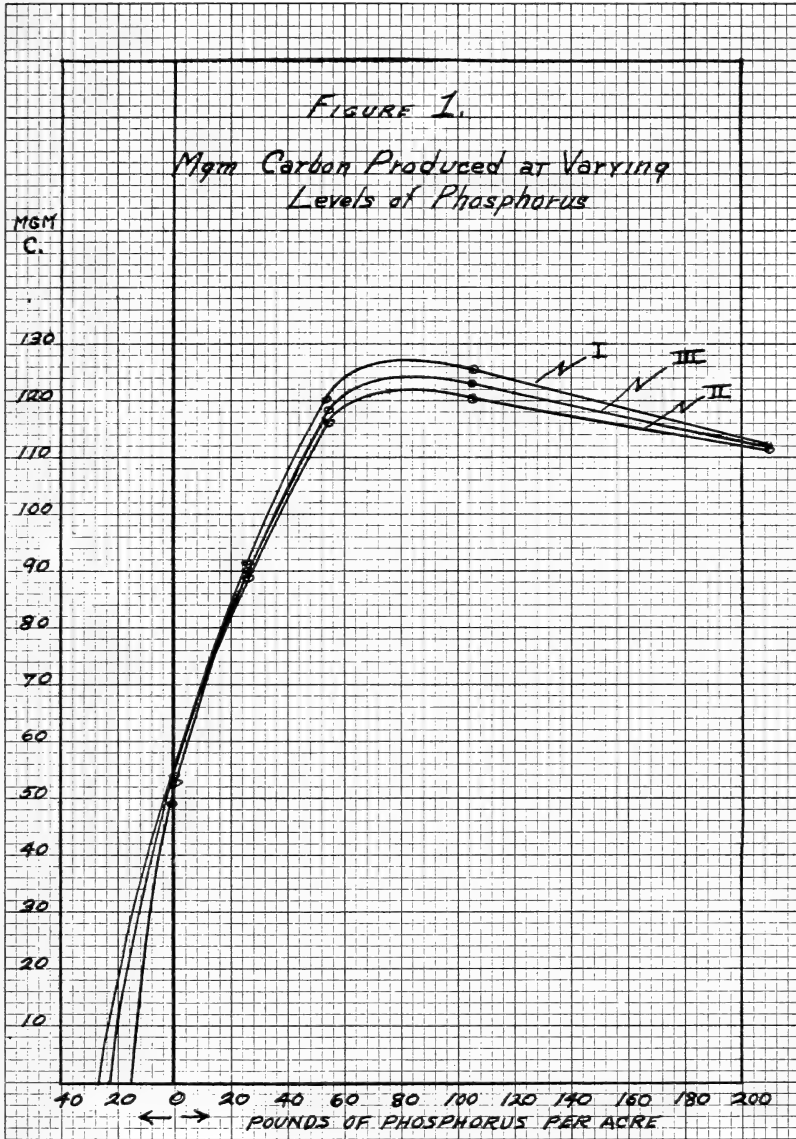

would increase in growth with a ratio commensurate with the amounts of phosphorus available. As these numbers increase, their rate of respiration (carbon dioxide) would also increase proportionately. By measuring the amounts of CO_2 evolved at varying rates of phosphorus supplied, an indication of the phosphorus available to these organisms could be ascertained. It was for this purpose that the following project was undertaken.

METHOD

Since the method presented is designed to be preliminary in nature, a soil type that was known to fix phosphorus in relatively large amounts was selected. A Red Bay sandy loam, taken from a corn field near Marianna, Florida, was utilized. The soil was air-dried and sieved through a 20-mesh screen. One-half pound quantities of soil were weighed and placed in the required number of clean two quart glass topped mason jars.

The nutrient level used was based on an application of 1,000 pounds of a 6-6-6 fertilizer per acre. Amounts of phosphorus were made to vary in each set of three replications from zero percentage P_2O_5 to 48 per cent, by increments of none, 6, 12, 24, and 48 per cent P_2O_5 . Calcium and magnesium as dolomitic limestone, and the minor elements in the form of "FTE"¹ were also added. These were applied at rates of 2,000 pounds and 200 pounds per acre respectively. As a rapid source of energy, sucrose, based on 1 gram per one-half pound of soil, was included. Sources of nitrogen, phosphorus, and potassium were added as the salts, NH_4NO_3 , Na_2HPO_4 , and KCl in solution form. By using measured amounts of these solutions, accuracy and uniformity of the experiment was increased. The following quantities were dissolved separately in one liter amounts of distilled water:

Nitrogen	1.94 gms. of NH_4NO_3
Phosphorus	1.36 gms. of Na_2HPO_4
Potassium	1.07 gms. of KCl
Carbon	500.00 gms. of Sucrose

One ml. of each solution, except sucrose, yields the equivalent of 6 per cent nitrogen, P_2O_5 and K_2O respectively. Thus, volumes zero, 1, 2, 4, and 8 ml. of the Na_2HPO_4 solution corresponded to the

¹ Fritted Trace Elements, Ferro Co. (Dupont product.)

desired variations of phosphorus. All quantities were calculated on the basis of 2,000,000 pounds per acre of mineral soil, 6-inch depth. As a source of energy, the sugar solution was added at the rate of 1 gm. per half-pound sample of soil, or the equivalent of 2 ml. of sugar solution. Dolomite and FTE powder were mixed, weighed, and incorporated in the soil. Since the volume of nutrient and energy solutions that were added to the soil were not sufficient to moisten the entire volume, it was decided to augment each portion of soil in the jars by a quantity of water, until all soils had the equivalent of 20 ml. of solution. The amount of water added was sufficient to bring the soil to about 40 per cent of saturation.

After the solutions had been added, the soil were thoroughly mixed to insure uniformity. The uncapped jars were placed in an incubator which had previously been set to maintain a temperature of 28 degrees C. These jars were allowed to remain uncapped for a period of 12 hours. Following this, 50 ml. quantities of 0.5 N. NaOH were placed in small, uniform size, dispensary bottles. By means of a fine wire secured around the neck of the bottle, they were lowered into the glass jars until their bases rested on the soil surface. The opposite end of the wire was allowed to hang over the rim of the jar. The jars were sealed and allowed to incubate for 31 hours at 28 degrees C. Temperature is critical and should be maintained at a uniform condition in all parts of the incubator.

At the termination of this period, the jars were removed from the incubator, unsealed, and the dispensary bottles removed. Each 50 ml. quantity was poured into a 125 ml. Ehrlenmeyer flask. To precipitate the carbon as the carbonate, an excess of 2 N. BaCl₂ was added. With phenolphthalein as an indicator, the remaining NaOH was titrated with 0.5 N. HCl. To determine the amounts of carbon produced,² the following formula was used:

Ml. of NaOH used—ml. standard HCl used x 3 = mgm. of carbon.

RESULTS

After titrating the remaining NaOH against the standard acid and employing the formula, the values expressed as mgm. of carbon for the three replications are shown in Table 1.

² Amounts may be expressed in mgm. CO₂ evolved by substituting the factor 11 for 3.

TABLE 1

Mgm. of Carbon Produced at Varying Levels of Phosphorus

Percent P ₂ O ₅ (Fertilizer Formula)	Lbs./Acre (Phosphorus Applied)	Replications		
		I	II	III
0	0.0	49.5	54.0	52.8
6	26.16	91.5	88.8	89.7
12	52.32	120.0	116.4	118.2
24	104.64	125.4	119.7	123.0
48	209.28	111.9	111.3	111.9

The mgm. of carbon plotted against the quantities of phosphorus, in terms of pounds per acre added, are shown on the graph (Figure 1). A smooth curve is constructed for each replica and extended to the base-line to determine the approximate pounds of available phosphorus per acre. For this particular sample of soil, the available phosphorus, as indicated by the graph, is between 15 to 27 pounds per acre.

DISCUSSION AND SUMMARY

The similarity of the three curves suggests a correlation between the amount of phosphorus available to the organisms and the amounts of CO₂ evolved, or the amount of carbon produced. Leaving the jars uncapped during the latent or initial stationary phase enables the microorganisms to adjust to the new environment and enter a phase of accelerated growth. All other factors being constant during this and the phase of logarithmic increase, phosphorus would serve as the limiting factor.

Preliminary experiments indicated that incubation in excess of 60 hours created a noticeable negative oxygen tension which may be assumed to adversely affect normal microbial growth and phosphorus utilization. All indications showed normal growth and uniform CO₂ evolution for the 30 hours incubation period. The break at the peak of the curves were assumed to be the effects of excessive phosphorus.

The slope of the smooth curves at the lower values for phosphorus strongly suggests the possibility that an extension of these lines to the base of the graph enables the investigator to determine the initial quantity of phosphorus available in the untreated sample

of soil. By fundamental geometric axioms, it becomes evident that the point of interception of the slope of the line with the abscissa, whether to the left or to the right of the ordinate, is basically the same. Therefore, in this case, the range of available phosphorus can be estimated to be between 15 and 27 pounds per acre for the untreated soil sample.

A new method, utilizing spontaneous microbial growth as a rapid, practical biological method for determining the approximate quantities of available phosphorus is offered. Microbial activity is shown to increase in proportion to the amounts of available phosphorus supplied. Future possibilities are suggested by correlation with field trials for establishing the amounts of available phosphorus in soils.

LITERATURE CITED

BUTKEWITSCH, W.

1909. Die Kultur des Schimmelspilzes *Aspergillus Niger* als Mittel zur Bodenuntersuchung. *Zhur. Opytn. Agron.* (Russian Jour. Landw.) 10: 136-141.

DALBERG, H. W., and R. J. BROWN

1932. A Study of the Neubauer and Winogradsky (*Azotobacter*) Methods as Compared with a Chemical Method for the Determination of Phosphate Deficiency in Western Soils. *Jour. Am. Soc. Agron.* 24: 460-468.

GREEN, R. A.

1932. The Applicability of the *Azotobacter* (Plaque) Method for Determining the Fertility Requirements of Arizona Soils. *Soil Sci.* 34: 83-94.

HALBERSEN, W. V., and W. G. HOGE

1942. The *Azotobacter* Plaque Test as Applied to the Determination of Phosphate Deficiency in Idaho Soils. *Jour. Am. Soc. Agron.* 34: 503-512.

MEHLICH, A., E. B. FRED, and E. TRUOG

1934. The *Cunninghamella* Plaque Method of Measuring Available Phosphorus in Soil. *Soil Sci.* 38: 445-461.

NEUBAUER, H., and W. SCHNEIDER

1923. Die Nahrstoffaufnahme des Keimpflanzen und ihre Anwendug suf die Bestimmung des Nahrstoffgehalts de Boden. *Ztschr. Pflanzener-nahr. u. Dungung.* (a) 2: 329-362.

NIKLAS, H., and H. POSCHENRIEDER

1932. Die Ausfuehrung der *Aspergillus* Methode zur Prufung auf Kali. *Ernahr. Pflanze.* 28: 86-88.

1936. Zur Feststellung der Magnesia-Dunge-Bederetigkeit und Magnesia-Dungewirkung Im Boden Mittels *Aspergillus Niger*. *Bodenk. u. Pflanzenernahr.* 1: 235-247.

NIKLAS, H., H. POSCHENRIEDER, and J. TRISCHLER

- 1930a. Eine Neue Microbiologische Methode Zur Feststellung der Dungebedurftigkeit der Boden. *Ztschr. Pflanzenernahr., Dungung, u. Bodenk.* (a) 18: 129-157.

- 1930b. Die Kultur des Schimmelspilzes *Aspergillus niger* zur Biochemischen Bestimmung de Kali und Phosphorsaurebedurftigkeit der Boden. *Ernahr. Pflanze.* 26: 97-103.

SACKETT, W. G., and L. C. STEWART

1931. A Bacterial Method for Determining Mineral Soil Deficiencies by Use of the Soil Plaque. *Colo. Agri. Exp. Sta. Bul.* 375: 1-36.

STEWART, L. C., W. G. SACKETT, D. W. ROBERTSON, and A. KEZER

1932. A Comparison of the Soil Plaque Method with the Neubauer and Hoffer Corn Stalk Methods for Determining Mineral Soil Deficiencies. *Colo. Agri. Exp. Sta. Bul.* 390: 1-59.

WINOGRADSKY, S.

1925. Etudes sur la Microbiologie du Sol: II. Sur les Microbes Fixateurs d'Azote. *Ann. Inst. Pasteur* 40: 455-520.

1927. Etudes sur la Microbiologie du Sol: III, Sur Le Pouvoir Fixateur les Terres. *Ann. Inst. Pasteur* 42: 36-62.

HERMAPHRODITISM IN A MOUSE RELATED TO STRAIN A¹

MICHAEL KLEIN
University of Florida

Although mice have been used extensively in research, few instances of lateral hermaphroditism have been reported in this species since Danforth first observed a gynandromorph in 1927 (Blotevogel, 1932; Fekete, 1937; Fekete and Newman, 1944; Hooker and Strong, 1944; Klein, 1955). The hermaphrodite last described (Klein, 1955) was discovered at autopsy in an albino mouse related to strain A/He. Recently, the author had occasion to repair a right inguinal hernia in an animal from the same colony. Inguinal hernias have been observed previously in association with hermaphroditism (Young, 1937; Grollman, 1947). When the mouse was anesthetized and the abdominal cavity entered, it was observed that the animal, which externally was indistinguishable from other males, had a testis on the left side but none on the right. The testis was located in the scrotum and although small, appeared in good condition. A vesicular and coagulating gland also were present on the left side. However, an ovary-like structure was discovered on the opposite side caudad to the right kidney. Associated with the latter gonad was a well developed uterine horn which measured 2 - 3 mm. in diameter. A firm 5 x 7 mm. mass was attached to the base of this horn and appeared outwardly to represent a rudiment of the left uterine horn. Following these observations, the hernia was repaired and the animal isolated for further study.

One week following the operation, the mouse was mated to a group of young adult non-virgin mice and the latter were inspected daily for evidence of mating. No vaginal plugs were observed during the two months which followed and no pregnancies ensued. In an attempt to induce pregnancy in the hermaphrodite, a viable sperm preparation was introduced into the cephalic end of the right uterine horn on five successive days. The mouse died several days thereafter and the genital tract was excised and fixed. Serial or semi-serial sections were prepared in some instances.

The following details were revealed upon microscopic examination:

¹ A contribution from the Cancer Research Laboratory, University of Florida, Gainesville, Florida.

I. *Testis and Male Sex Accessories.* The seminiferous tubules were compact and appeared well developed. Cells in all stages of spermatogenesis including spermatozoa were found in the tubules. The vas deferens contained a well folded mucosa which was lined with a tall columnar epithelium. There were fewer folds than normal in the mucosa of the vesicular gland and these generally projected but slightly into the lumen. A coagulating gland adjoined the vesicular gland and contained a well folded mucosa composed of tall columnar cells in good condition. Both ventral and dorsal prostates were observed and the tubules of each appeared normal.

II. *Ovary and Femal Sex Accessories.* Microscopic examination disclosed the right gonad to be an ovary. The germinal epithelium was intact and invaded the stroma in places. Granulosa cells, occasionally in glandular arrangement, were observed throughout the ovary while follicles were almost entirely absent. The gonad contained an abundance of interstitial tissue with large and frequently deeply pigmented cells. The uterus contained a slightly folded mucosa with columnar to tall columnar cells. Secretion, desquamated cells, leucocytes, cellular debris, and spermatozoa were found within the lumen. The globular mass at the base of the right uterine horn contained a large lumen which joined the lumen of the right horn and was lined with a stratified squamous epithelium similar to that in the vagina. No passageway was found between the lower end of the uterine tract and the urethra.

Microscopic examination of the adrenals and kidneys, in each instance, revealed structures indicative of the male rather than the female (Crabtree, 1941; Howard Miller, 1927). Thus the zona fasciculata and zona reticularis of the adrenals were not separable and the cells lining the parietal layer of Bowman's capsule in the kidneys were cuboidal to low columnar.

LITERATURE CITED

BLOTEVOGEL, W.

1932. Hermaphroditismus glandularis s. verus unilateralis bei der maus. *Zentralbl. Gynakol.*, 56: 2250-2252.

CRABTREE, C. E.

1941. The structure of Bowman's capsule as an index of age and sex variation in normal mice. *Anat. Rec.*, 79: 395.

DANFORTH, C. H.

1927. A gynandromorph mouse. *Anat. Rec.*, 35: 32.

FEKETE, E.

1937. A case of lateral hermaphroditism in *Mus musculus*. *Anat. Rec.*, 69: 151.

FEKETE, E., and L. B. NEWMAN

1944. A case of hermaphroditism in the mouse. *Yale J. Biol. and Med.*, 17: 395.

GROLLMAN, A.

1947. *Essentials of Endocrinology*. J. B. Lippincott Co., Washington Square, Philadelphia 5, Pa.

HOOKEE, C. W., and L. C. STRONG

1944. Hermaphroditism in rodents, with a description of a case in the mouse. *Yale J. Biol. and Med.*, 16: 341.

KLEIN, M.

1955. Unilateral hermaphroditism in the mouse. *Anat. Rec.* In press.

HOWARD MILLER, E.

1927. A transitory zone in the adrenal cortex which shows age and sex relationships. *Am. J. Anat.*, 40: 251.

YOUNG, H. H.

1937. *Genital Abnormalities, Hermaphroditism, and Related Adrenal Diseases*. Williams and Wilkins Co., Baltimore, Md.

A.A.A.S. RESEARCH GRANTS AVAILABLE

The Academy has available a little over \$100 to be awarded for research grants from the American Association for the Advancement of Science. Applications for all or part of these funds may be made to Dr. Clarence P. Idyll, Chairman of the Awards Committee, Marine Laboratory, University of Miami, Coral Gables, Florida.

Requests should include: 1. Name and address of applicant; 2. A brief statement of research project; 3. The special purpose for which the funds are to be used; 4. The amount of the grant. Applications should be in the hands of the Chairman prior to the Annual Meeting December 8, 1955, and the awards will be announced at the Annual Banquet.

AN APOLOGY

In a recent review of Dr. James G. Needham and Minter Westfall's "A Manual of the Dragonflies of North America," I made an unpardonable error in stating that the senior author was deceased. No offense was intended, but I am to be severely censured for not having checked the facts.—Frank N. Young.

INSTRUCTIONS FOR AUTHORS

Contributions to the *JOURNAL* may be in any of the fields of Sciences, by any member of the Academy. Contributions from non-members may be accepted by the Editors when the scope of the paper or the nature of the contents warrants acceptance in their opinion. Acceptance of papers will be determined by the amount and character of new information and the form in which it is presented. Articles must not duplicate, in any substantial way, material that is published elsewhere. Articles of excessive length, and those containing tabular material and/or engravings can be published only with the cooperation of the author. Manuscripts are examined by members of the Editorial Board or other competent critics.

MANUSCRIPT FORM.—(1) Typewrite material, using one side of paper only; (2) double space *all* material and leave liberal margins; (3) use 8½ x 11 inch paper of standard weight; (4) do not submit carbon copies; (5) place tables on separate pages; (6) footnotes should be avoided whenever possible; (7) titles should be short; (8) method of citation and bibliographic style must conform to *JOURNAL* style—see Volume 16, No. 1 and later issues; (9) a factual summary is recommended for longer papers.

ILLUSTRATIONS.—Photographs should be glossy prints of good contrast. All drawings should be made with India ink; plan linework and lettering for at least ½ reduction. Do not mark on the back of any photographs. Do not use typewritten legends on the face of drawings. Legends for charts, drawings, photographs, etc., should be provided on separate sheets. Articles dealing with physics, chemistry, mathematics and allied fields which contain equations and formulae requiring special treatment should include India ink drawings suitable for insertion in the *JOURNAL*.

PROOF.—Galley proof should be corrected and returned promptly. The original manuscript should be returned with galley proof. *Changes* in galley proof will be billed to the author. Unless specially requested page proof will not be sent to the author. *Abstracts* and *orders for reprints* should be sent to the editor along with corrected galley proof.

REPRINTS.—Reprints should be ordered when galley proof is returned. An order blank for this purpose accompanies the galley proof. The *JOURNAL* does not furnish any free reprints to the author. Payment for reprints will be made by the author directly to the printer.

500-75
1.F6F6E

Quarterly Journal

of the

Florida Academy of Sciences

Vol. 18

December, 1955

No. 4

Contents

Hulings and Olson—Subsurface Beach Sands of Alligator Harbor	227
Dyer—Jacksonville and Miami: Urban Contrasts in Florida ...	233
Report on the Academy Conference	238
Grace—A Survey of the Economic, Educational and Social Resources of Bradford County, Florida	239
Hussey and Elkins—Review of the Genus <i>Doldina</i> Stal (Hemiptera: Reduviidae)	261
Caldwell, Carr and Hellier—A Nest of the Atlantic Leatherback Turtle, <i>Dermochelys coriacea coriacea</i> (Linnaeus), on the Atlantic Coast of Florida, with a Summary of American Nesting Records	279
Briggs and Caldwell—The Characteristics and Distribution of the Spotted Cusk Eel, <i>Otophidium omostigmum</i> (Jordan and Gilbert)	285
Caldwell, Carr and Hellier—Natural History Notes on the Atlantic Loggerhead Turtle, <i>Caretta caretta caretta</i>	292
Callaway—Interaction of Pi^- Mesons with Light Nuclei	303

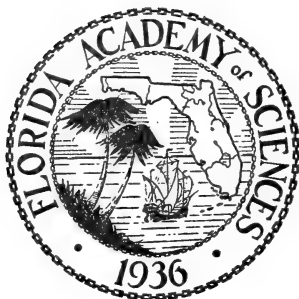

Vol. 18

DECEMBER, 1955

No. 4

QUARTERLY JOURNAL OF
THE FLORIDA ACADEMY OF SCIENCES

A Journal of Scientific Investigation and Research

Editor—J. C. DICKINSON, JR.

Associate Editor—JOHN D. KILBY

Published by the Florida Academy of Sciences

Printed by the Pepper Printing Co., Gainesville, Fla.

The business offices of the JOURNAL are centralized at the University of Florida, Gainesville, Florida. Communications for the editor and all manuscripts should be addressed to the Editor, Department of Biology. Business communications should be addressed to R. A. Edwards, *Secretary-Treasurer*, Department of Geology. All exchanges and communications regarding exchanges should be addressed to The Gift and Exchange Section, University of Florida Libraries.

Subscription price, Five Dollars a year

Mailed May 8, 1956

THE QUARTERLY JOURNAL OF THE FLORIDA ACADEMY OF SCIENCES

VOL. 18

DECEMBER, 1955

No. 4

SUBSURFACE BEACH SANDS OF ALLIGATOR HARBOR¹

NEIL HULINGS and F. C. W. OLSON
Florida State University

In May, 1955, a soil sample was taken four feet below mean sea level (MSL) from the north shore of Alligator Harbor (Station 1, Figure 1). A hasty examination revealed the presence of several large (2 to 3 mm), sharp, angular grains. Since the appearance of these grains was unlike any yet observed in the present beaches of this region, it was at first thought that these might be from river sands. Apparent support for this hypothesis came from a study of the topographic map of the land between Ochlockonee Bay and Alligator Harbor. There are two low regions almost cutting across the land which could be interpreted as the course of an ancient river. To test this hypothesis, mechanical soil analyses were made from three borings (Stations 1, 2 and 3, Figure 1) on the north shore of the harbor.

Alligator Harbor is located at 29° 53.9' N. and 84° 22.9' W. in Franklin County, Florida. It is the site of the Florida State University Marine Laboratory operated by the Oceanographic Institute. The harbor is about 1¼ miles wide, 4 miles long and is oriented roughly east to west. It is comparatively shallow, the mean depth at mean low water being about 4 feet. The northern side of the harbor is extensively covered with *Juncus* marshes. A complicated system of channels run through these marshes. The southern side of the harbor is mostly sandy beaches. Ochlockonee Bay is located about 4 miles north of Alligator Harbor. The Ochlockonee River empties into the Bay approximately 5½ miles northwest of the harbor. The Ochlockonee River is a part of the Crooked-Ochlockonee-Sopchoppy River System. A detailed de-

¹ Contribution No. 38 from the Oceanographic Institute of Fla. State Univ.

MAY 17 1956

scription of the hydrography of Alligator Harbor has been given by Olson (1955).

We wish to express our thanks to Dr. Stephen Winters for his helpful suggestions during the course of this investigation.

PROCEDURE

Figure 1 shows the locations of the three stations. These were sampled at or near low tide because the low lying marsh land is usually flooded at high tide.

It was hoped to use a Priddy sampler (Priddy, *et al*, 1955) in the top layer of marsh mud and muck. While this sampler is unexcelled for mud of thin to moderate consistency, some difficulty was encountered with the stiffer mud in the top one foot layer. At depths from one to two feet, the mud was usually thinner and the Priddy sampler could be used. Below this depth, a posthole digger of the auger type was effective. The maximum depth reached by the auger was 8 feet. An effort was made to take samples at half foot intervals, but when obvious changes in soil type were noted, samples were taken at closer intervals. The sample size was about 300 grams.

Since the soils of this area do not slake after drying, a wet method of soil analysis is necessary. The Pedometer method described by Rouch (1943) had previously been used with some success for bottom sediments in the harbor and for this reason it was used in this study. In the Pedometer method, about 10 cc of the sample is placed in a flat-bottomed glass tube 15 mm in diameter and 24 cm long. Water is added to within an inch of the top and the mixture thoroughly shaken. The tube is then placed vertically in a rack and the soil is allowed to settle. The sand falls out within 40 seconds. After one hour, the ratio of the height of the sand to the total height is determined. This ratio is a measure of the amount of sand present in the sample on a volume basis. It is expressed as % sand.

Unfortunately, the more refined method of elutriation described by Priddy *et al* (1955) did not appear in print until this study was nearing completion. Since our primary interest was in sand size distribution, it was felt there was little to be gained in repeating the work with the elutriation method.

Sand sizes were determined with a set of U. S. Standard Sieves of the following mesh:

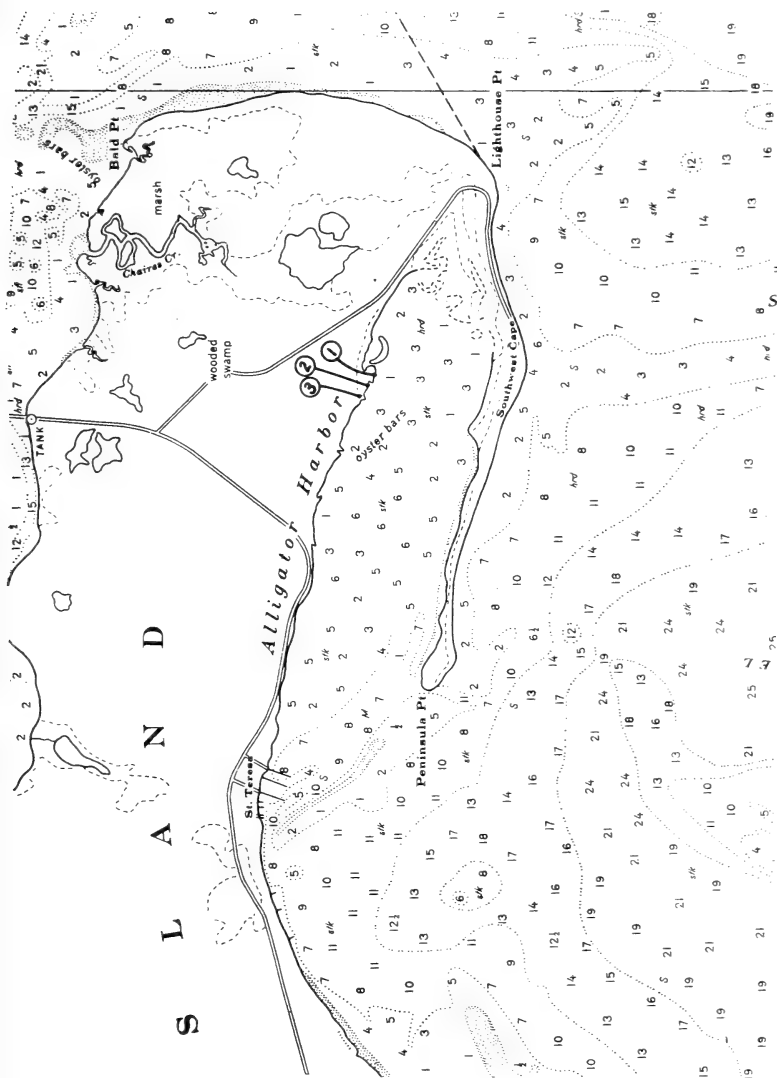

Figure 1. Map showing locations of Stations 1, 2 and 3. Depths indicated are in feet below mean low water. From U. S. Coast and Geodetic Survey Chart No. 1261.

No. 10 — 2.0 mm	No. 60 — 0.25 mm
No. 20 — 0.84 mm	No. 80 — 0.177 mm.
No. 40 — 0.42 mm	No. 100 — 0.149 mm.

The sample was placed on the top of the nested sieves, thoroughly washed and then dried in a drying oven after which it was shaken in an up-and-down and rotating manner by hand for 4 minutes. From the weights of sand on the various screens, the median diameter, sorting coefficient and skewness were obtained by the quartile method (Krumbein, 1939). Quartiles were obtained by plotting cumulative frequencies on semi-log paper. Samples containing less than 40% sand were not analyzed. The results are given in Table 1.

TABLE 1
Results of Analyses of Soil Samples

Depth (Ft. Below MSL)	Md (mm)	So	Sk	% Sand
Station 1				
4.2 -----	0.29	1.41	0.96	73
4.8 -----	0.26	1.42	0.93	70
5.6 -----	0.30	1.38	0.99	64
5.7 -----	0.28	1.42	0.92	70
Station 2				
2.7 -----	0.26	1.44	0.98	43
3.3 -----	0.30	1.36	0.93	62
3.7 -----	0.27	1.40	1.00	59
4.3 -----	0.30	1.41	0.90	59
4.6 -----	0.31	1.36	0.95	71
5.0 -----	0.29	1.45	0.99	68
Station 3				
4.7 -----	0.30	1.37	0.93	54
5.2 -----	0.30	1.41	0.99	58
5.8 -----	0.30	1.41	0.96	57
6.3 -----	0.32	1.42	0.90	64
6.8 -----	0.32	1.42	0.95	66
7.2 -----	0.28	1.44	1.00	68
7.5 -----	0.30	1.40	0.92	87

From a microscopic examination of the grains, it appeared that about 85% are subrounded. The remaining 15% are subangular or rounded with the latter dominating. The sand was almost entirely clear quartz with only an occasional grain of magnetite. Other heavy minerals were practically absent. Remains of invertebrates were very scarce. On rare occasions broken tests of arenaceous foraminifera were noted. No trace of mollusk shells or

fragments was found. Some of the sand grains appeared to be coated with iron oxide (of organic origin?) giving them a pink to reddish tinge.

A thin flocculent layer formed on top of some of the tubes in the Pedometer test. A cursory examination revealed a few sponge spicules and diatom tests but most of the material was fine plant debris.

DISCUSSION

The sands analyzed in this study were remarkably uniform as Table 1 clearly indicates. The median diameter, sorting and skewness seem to vary neither with depth nor with station. It is interesting to compare these results with those previously described by Olson (1955) for Alligator Harbor and the adjacent Gulf beach. This is done in Table 2.

TABLE 2
Comparison of Sand Analyses

Region	No. of Samples	Md			So			Sk		
		Max.	Min.	Avg.	Max.	Min.	Avg.	Max.	Min.	Avg.
Alligator Harbor subsurface	17	0.32	0.26	0.29	1.44	1.36	1.40	1.0	0.9	0.95
Alligator Harbor beach	21	0.59	0.25	0.48	1.5	1.2	1.3	1.2	0.9	1.1
Alligator Harbor outer Gulf Beach	12	0.52	0.34	0.40	1.5	1.1	1.3	1.3	0.8	1.2

Since beach sands are generally finer offshore than at the water's edge, one may expect that the subsurface sands be finer than the present beach sands. A more difficult factor to evaluate is the different techniques used in sand analysis. In the present study, the wet sieve method was used but the dry sieve method was used for the beach sands. Due to clumping, one may expect a somewhat higher median diameter with a dry sieve.

We may conclude that the subsurface sands of Alligator Harbor are similar to the present beach sands and that they represent a homogenous accumulation of beach sand. The conjecture that river sands were deposited along the north shore of Alligator Harbor is not substantiated by these findings.

As an isolated observation, this conclusion can hardly be of great interest. However, in relation to the problem of determining the history of the Alligator Harbor sand spit, it becomes an essential piece of data. Some of the complexities of this problem have already been mentioned (Olson, 1955). Among them are the following facts: (1) mean sea level at Cedar Keys has risen about 0.4 feet in the past 10 years and about one foot at Galveston in the past 40 years (Marmar, 1954); (2) many dead pine stumps are now under water on the outer beach of Alligator Point; (3) the mean depth of Alligator Harbor was practically the same in 1867 as in 1954; (4) Indian pottery found near Drum Point (a small cusped spit inside Alligator Harbor) is from a culture at least 1200 years old (800 A. D. or before); (5) a Carbon 14 analysis from a sample taken at Shell Point (14 miles from Alligator Harbor) indicates that MSL at 400 A. D. was at least 2.85 feet below present MSL.

To these we may now add: (6) subsurface sands to a depth of 7 feet below MSL on the north shore of Alligator Harbor closely resemble present beach sands. Although it would be premature to attempt to draw conclusions from these 6 items, yet from them we may gather hope that soon enough data will be available to solve in large measure the problem of determining the recent geological history of Alligator Harbor.

REFERENCES

- KRUMBEIN, W. C.
1939. Graphic presentation and statistical analysis of sedimentary data. In *Recent Marine Sediments*. Parker D. Trask, Ed. The American Association of Petroleum Geologists, Tulsa, Oklahoma.
- MARMER, H. A.
1954. Tides and sea level in the Gulf of Mexico. In *Fishery Bulletin* 89, U. S. Fish and Wildlife Service, vol. 55.
- OLSON, F. C. W.
1955. The hydrography of Alligator Harbor, Franklin County, Florida. Contribution 28, Oceanographic Institute, Florida State University. Mimeographed.
- PRIDDY, R. C., R. M. CRISLER, JR., C. P. SEBREN, J. D. POWELL and H. BURFORD
1955. Sediments of Mississippi Sound and inshore water. *Mississippi State Geological Survey Bulletin* 82.
- ROUCH, J.
1953. *Traite d'oceanographie physique-sondages*. Payot, Paris.
- Quart. Journ. Fla. Acad. Sci. 18(4), 1955.

JACKSONVILLE AND MIAMI: URBAN CONTRASTS IN FLORIDA ¹

DONALD R. DYER
University of Florida

Jacksonville and Miami, the two largest urbanized areas in Florida, contrast in several respects—natural, physical, social, and economic. To those who have visited or have lived in the two places, undoubtedly quite striking contrasts in mental images are brought to mind. In fact, if one were asked in what ways the two are *similar*, one would hesitate—probably for a long time—before answering. Such a dilemma, however, is common in comparisons of urban centers. One school of thought in the field of geography emphasizes that geographic studies should be concerned primarily with descriptions of *differences* from place to place on the earth. Although geographic studies have been concerned traditionally with the *land*, modern geographic investigations have been expanded to include also visible *non-natural* features, such as manmade alterations of the landscape—buildings, roads, etc. This paper deals with contrasts between the landscapes of Jacksonville and Miami, including the populations.

Jacksonville, situated on the deep-water estuary of the wide St. Johns River in northeastern Florida, is essentially a commercial city with good highway and railway connections to other parts of North Florida and the Southeast. Miami, situated near the southeastern extremity of peninsular Florida, is essentially a resort city with excellent highway and railway connections to the eastern U. S. and airway connections to the U. S. and to Latin America.

Contrasting in locations, the two cities also contrast in sites (Fig. 1). Jacksonville's site is riverside on the bend of a wide, deep river about 15 miles from the sea; topography is mostly level, with low bluffs of 20 to 40 feet on the east side of the river. Miami's site is bayfront, at the mouth of a small river on a wide, shallow bay separated from the ocean by a string of low, sandy islands; topography is flat, being mostly 10 to 15 feet above sea level.

Reflecting the process of settlement from north to south through peninsular Florida after the cession of Florida to the United States

¹ Read before the 20th Annual Meeting of the Academy, at the University of Miami, December 1955.

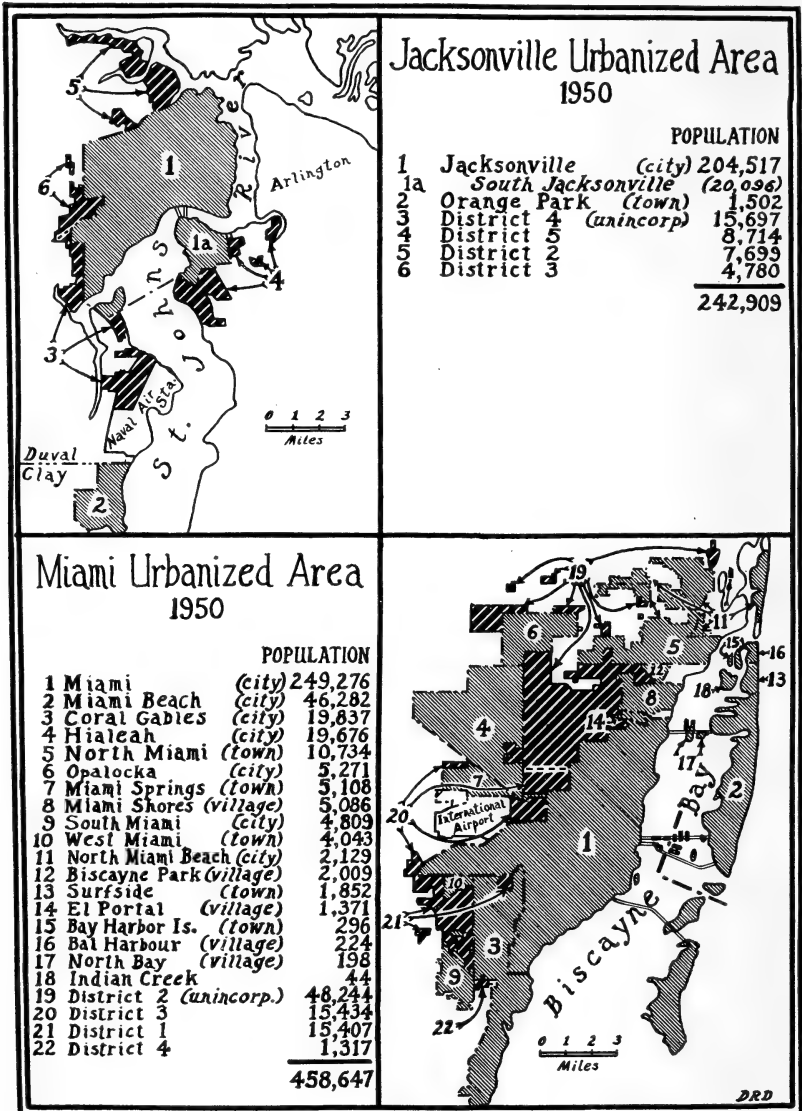

in 1819, Jacksonville was platted in 1822 but Miami not until 1896. Jacksonville's growth was slow until after the Civil War; but with a railway connection westward after 1868 and active river commerce southward up the St. Johns River after 1876, its population increased to 17,000 in 1890 before Miami was born. Railway connections were made to the north by 1881 and southward to Tampa by 1885. Jacksonville's connection down the east coast of Florida extended to St. Augustine after 1885, to West Palm Beach in 1894, and to Miami in 1896. Called by many "City of Hotels" and "Winter City in Summer Land," Jacksonville was an outstanding tourist city during the 1880s and 1890s. Port facilities really began to be constructed on modern lines in Jacksonville after the disastrous fire of 1901; harbor improvements made in 1906, 1916, and 1945 have successfully deepened the channel to 34 feet. Construction of the first highway bridge across the St. Johns parallel to the railway bridge of 1890 was completed in 1921, and by 1932 South Jacksonville had been annexed. A second highway bridge was finished in 1941, and a third and fourth recently.

Although Miami was slow to start, its jolt into life with the arrival of the tourist-laden Florida East Coast Railway in 1896 was forceful. Counting more than 5,000 by 1910, Miami's population jumped to nearly 30,000 in 1920 and was close behind Jacksonville with 110,000 in 1930 after the boom of the 1920s (Table 1). Taking into account only populations within city limits, Jacksonville and Miami were almost identical in 1940; however, considering also the closely-settled fringe areas of the cities, Miami exceeded Jacksonville by about 30,000. The gap in population between the two cities was widened during the 1940s until Miami had 250,000 within the city and another 210,000 in the urban fringe areas in 1950, in contrast to 205,000 in Jacksonville city and less than 40,000 on the fringes. The Greater Miami urbanized area encompassed 18 incorporated villages, towns, and cities hugging the central city in 1950 (Fig. 1). The largest were Miami Beach (46,000), Coral Gables (20,000), Hialeah (20,000), and North Miami (11,000).

The initial population contrast, then, is that Jacksonville expanded gradually and steadily absorbed fringe areas, whereas Miami exploded with fringe areas being filled in rapidly between the central city and the numerous suburbs. Other contrasts in population are racial composition, place of origin, age composition, and birth rate (Table 1). First, Jacksonville's population is about 35% colored,

TABLE 1
Selected Data for Jacksonville and Miami

	Jacksonville City—Urbanized Area		Miami City—Urbanized Area	
Population: 1900	28,420		1,681	
1910	57,699		5,471	
1920	91,558	est. 95,000	29,571	est. 32,000
1930	129,549	est. 135,000	110,637	est. 130,000
1940	173,065	est. 195,000	172,172	est. 225,000
1950	204,517	242,909	249,276	458,647
Non-white (1950)	35.5%	30.9%	16.3%	12.2%
Foreign-born white	2.1	2.1	10.8	10.9
Median age (1950)	31.0 yrs.	30.1 yrs.	35.8 yrs.	34.4 yrs.
Under 5 years of age	10.4%	11.1%	7.7%	8.8%
Over 65 years of age	6.5	6.2	8.5	7.8
Birth rate (live births per 1,000 population) ..	30.2		20.3	
Median family income (1949)	\$2,676	\$2,853	\$3,004	\$3,178
Median value of owner- occupied 1-dwelling unit structure	\$6,943		\$10,440	
Median gross monthly rent	\$38.69		\$51.43	
Labor force:				
Retail trade	19.5%	19.7%	24.6%	23.7%
Wholesale trade	6.3	6.5	4.8	4.7
Manufacturing	13.4	13.0	8.0	8.0
Transportation	13.9	13.7	11.0	11.3
New residential construction	\$9,957,000		\$26,232,000	
1-family structures		86%		56%
New non-residential construction ..	\$8,269,000		\$14,995,000	

Source: U. S. Bureau of the Census. *County and City Data Book: 1952.* Washington, 1953.

Miami's 16%, making Jacksonville typical of Southern cities and Miami typical of Northern cities. Second, Jacksonville's population is largely native-Floridian with a large segment of Georgia-born persons and other Southerners. Miami's population, on the other hand, is only about one-fourth native-Floridian with large numbers of northern-born people. Moreover, more than 10% of Miami's population is foreign-born; Jacksonville has only 2% foreign-born. Third, Jacksonville's population is younger than Miami's; the median age is 31 and 36, respectively, reflecting the greater number

of retired persons in Miami, where 8½% of the people are 65 years of age or older. Fourth, Jacksonville's birth rate is somewhat higher than Miami's—30 per thousand versus 20 per thousand; part of this difference reflects the greater number of Negroes in Jacksonville, part represents the younger age composition in Jacksonville.

In summary of differences in populations, if one walked the streets of Jacksonville he would expect to see one person in 3 as colored, few old people but relatively numerous children, and would hear predominantly Southern accents; on the other hand, in Miami one would expect to see only one in 6 as colored, 1 of 11 of age 65 or over, relatively few children, and northern or mid-western accents—as well as frequent signs in store windows "Se habla español."

Economic contrasts between the two cities appear in the median family income. In 1949, the median income was \$2,676 in Jacksonville and \$3,004 in Miami. Such contrast also appears in values of houses and in rental rates. The median values of owner-occupied, single-dwelling units were about \$7,000 in Jacksonville and \$10,000 in Miami in 1950. Median rents were just under \$40 per month in Jacksonville, but more than \$50 per month in Miami.

Economic contrasts also appear in the labor forces of the two cities. In both instances the largest number of the employed labor force are engaged in retail trade; however, Jacksonville's 19.5% is about the same as the U. S. urban average, but considerably below Miami's 24.6%. The wholesale trade, manufacturing, and transportation segments of the labor force are relatively more important in Jacksonville than in Miami. In the national picture, both cities stand above the average city in wholesale trade and in transportation, but below the national average in manufacturing. Although manufacturing plants are more numerous in Miami than in Jacksonville, the average size is nearly 3 times as large in Jacksonville. The average of the 267 factories in Jacksonville in 1950 employed 46 workers and added \$244,000 in value to products; Miami's averages were 17 employees and \$93,000 value added by manufacture.

Finally, construction activities in Jacksonville and Miami indicate contrasting emphases. In 1950, new building in Jacksonville was distributed 55% residential / 45% nonresidential, whereas in Miami it was about 65% residential / 35% nonresidential. In other words,

emphasis has been more on business, industrial, and other non-residential uses in Jacksonville than in Miami. In the field of residential construction, marked contrast in emphasis appears in single-family structures in Jacksonville (86% of the total) and in multi-family structures in Miami (44% of total). Continued contrasts in emphasis on apartment building will result in greater density of population in Miami as well as in larger total population.

Estimates of 1955 populations of counties in Florida indicate that Duval has 397,000 and Dade 714,000. These both represent growths somewhat higher than the growth rates of 1940-1950. They indicate additions of nearly 100,000 people to Duval County and more than 200,000 to Dade County in only 5 years. Expansion is particularly rapid in South Jacksonville and across in the Arlington section aided by the construction of two new bridges across the St. Johns. Expansion is rapid in all sections of the Miami area, even to the point of new land dredged from the bay.

Quart. Journ. Fla. Acad. Sci. 18(4), 1955.

REPORT ON THE ACADEMY CONFERENCE

The Annual Academy Conference held in conjunction with the annual meeting of the American Association for the Advancement of Science convened in Atlanta on December 28, 1955, with President Leland H. Taylor of West Virginia University presiding. Father Patrick H. Yancey of Spring Hill College Alabama is President elect of the conference and Mrs. Thelma Heatwole of Staunton, Virginia, Secretary-Treasurer. The morning business session was devoted to reports of committees and reports by delegates on the activities of the various academies. Well over half of the 41 state, regional or city academies were represented and some of the reports proved of considerable interest. Most of the Academies have various sections: publish proceedings, news letters or a journal at more or less regular intervals—sponsor Junior Academies, Science Talent Searches, Science Fairs and in many cases Collegiate Academies. Some reported financial problems, but it was interesting to note how many had solved their financial problems by establishing industrial memberships. Without exception those academies which have tried this type of membership reported that it was a very effective and easy method of obtaining financial support. In most instances it was started to pay for a definite project such as publications, Science Talent Search, Science Fair, etc., but very soon more money was received from this source

(Continued on Page 284)

A SURVEY OF THE ECONOMIC, EDUCATIONAL AND SOCIAL RESOURCES OF BRADFORD COUNTY, FLORIDA

H. T. GRACE
Florida Southern College

INTRODUCTION

The cultural pattern of Bradford County has undergone many changes in the last century. Little vestige of the five groups of people that vied for the control of North Florida can be found today. There is little doubt that permanent settlement by the white man was delayed over 100 years by the bitter "five-way" struggle for the control of this part of Florida.

Should Chief Micanopy of the Seminole Indians return to Bradford County today, he would no doubt be startled to find automobiles and trucks speeding along paved highways. Gone are the "Spanish Trails" and missions as well as the federal troops stationed at Fort Crabbe, Fort Van Courtland, and Fort Harlee, that helped force his people to migrate to Oklahoma or to the "land of game and 'gators" in the Everglades. He would miss the dense pine, oak, and hickory virgin forests that covered most of the county. Instead, he would hear the "put-put" of the tractors cultivating truck crops that have replaced the forest (Bradford County Telegraph, 1954:4).

Even more strange to Chief Micanopy would be the thriving city of Starke or the towns of Lawtey, Brooker, and Hampton. In the vicinity of these towns some of his ancestors had once built palisades of logs to protect the Indian villages surrounded by their patches of corn, pumpkin, and beans.

Bradford County was formed in 1861 and was divided in 1921 to form both Union and Bradford counties. It has a total area of 293 square miles or 187,520 acres and is the third smallest county in the State. The mean annual temperature is 69.1°F. with an average rainfall of 49.22 inches. The growing season averages 271 days with the first average killing frost November 26 and the last February 28 (F. S. C. C. Abstract of Florida Counties, 1944:8).

Bradford, like a number of other counties of North Florida, has gone through several stages of development under the Indian and the white man. Some of the stages were fishing and hunting;

pastoral and hoe culture; subsistence and exploitive agriculture including forest products; intensive agriculture including row crops, vegetables, and fruits; and finally some mining and manufacturing.

Bradford County was selected for this study because its social and economic problems are somewhat typical of a rural agricultural county of North Florida having very little manufacturing, a minimum of tourist influence, and a relatively high Negro population when compared with other counties. Located some 46 miles southwest of Jacksonville, the farms in the county are small in size, owned and operated in the main by farmers whose ancestors migrated from nearby Southern states.

In the study of Bradford County's social and economic resources, our attention should be focused upon four major changes that have taken place in Florida since 1920: *first*, the shift from rural to urban residence; *second*, the decline in the ratio of Negro to white population; *third*, the increase in the size of farms and land holdings; and *fourth*, the mechanization of agriculture. Each of these will be discussed later; however, brief mention here of the increased land holdings will give some idea of the vast changes that have taken place.

From 1940 to 1950 the average farm holdings in Bradford County almost doubled in size while those in the State more than doubled. In the State most of the large tracts of land in rural areas were purchased because of their suitability for four primary purposes: *first*, timber, pulpwood, forest products, or naval stores; *second*, citrus fruits; *third*, winter vegetables; and *fourth*, pastures for beef or dairy cattle. In the main, less out-of-state capital was involved in the purchase of pasture and ranch lands than was true of the forest and citrus lands.

This study will explore certain influences, such as climate, soils, and labor, that have kept the farms of Bradford County small in size and will note some of the effects that land tenure and land utilization may have had upon the social and economic life of the white and Negro families. Other questions that will receive limited consideration are the following: What are some of the factors that may have influenced population changes in the county? How has the Negro fared in relation to the white man? Have the farmers of the county been able to support their families from their farm income in recent years? Do the social and economic problems con-

fronting the people of a rural county like Bradford have any implication for educators and social scientists?

In the social and economic development of a region, man is the most important factor. He furnishes the labor, mental and physical, to organize and execute the process of bringing about a change in the cultural landscape. Improved truck and rail transportation, and technological developments in farm machinery have changed the man-land ratio as well as the know-how of the people. Perhaps the 20th century has witnessed more scientific and technological changes in farming than all previous years since this country was founded.

GROWTH OF POPULATION

A better understanding of the population changes in Bradford County can be had by reviewing briefly some of the major population patterns of the State. In the last three decades, Florida has experienced several population changes that include: (1) an unprecedented migration to cities and resultant growth of urban district (410.0 per cent increase); (2) a decline of rural farm population (28.8 per cent to 8.4 per cent); a decline from $\frac{1}{3}$ to $\frac{1}{5}$ in the ratio of Negroes to whites; and (4) a high immigration from the North and the East.

Almost all of the counties of peninsular Florida have retained practically all of their natural increase in population and absorbed large numbers through migration. This is in contrast with most rural agricultural counties in North Florida where the natural increase is high and many inhabitants are lost to other areas by migration. For example, Florida experienced a 29 per cent increase in population in the decade of 1930 to 1940, while thirteen rural agricultural counties in the State including Bradford showed a net decline in population. Between 1940 and 1950 there were eighteen rural counties that showed a net decline in population while the State as a whole was gaining 46 per cent. Sixteen of these 18 counties were in North Florida (Becker, 1954:73).

Composition of Bradford County's Population: During the decade of 1940 to 1950 the population of the county increased from 8,717 to 11,451, which was an increase of 2,714 or 31.4 per cent. The natural increase was 2,194 or 25.2 per cent, while the net immigrations were 546, or 6.2 per cent. There was a decline of 1,413 or

AGE - SEX PYRAMID FOR BRADFORD COUNTY, FLORIDA

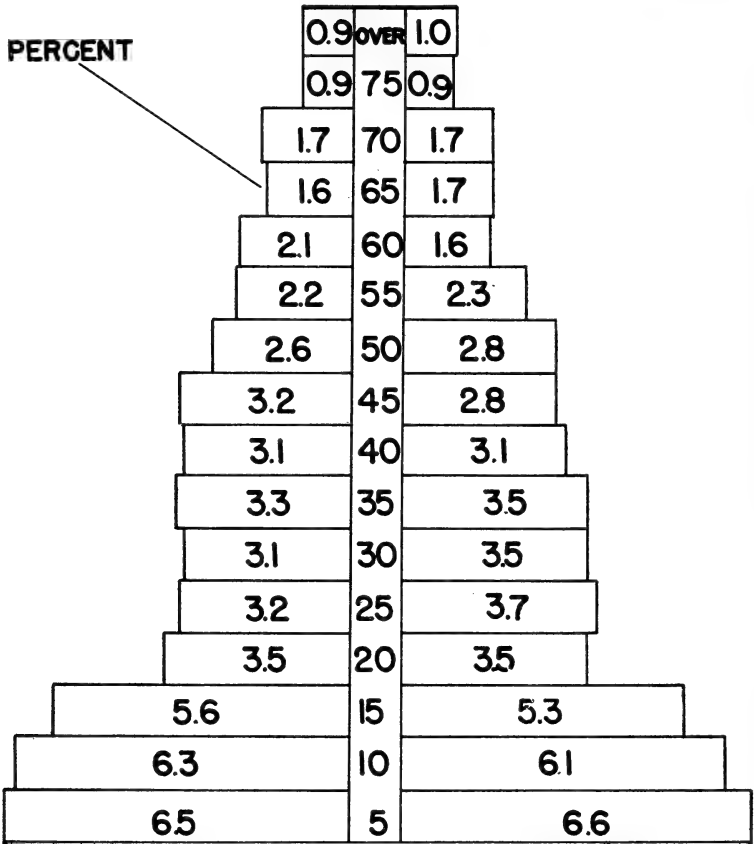

FIG. 1

MALE AGE FEMALE

SOURCE U. S. CENSUS, 1950, FLA. PB10

AGE - SEX PYRAMID FOR JACKSONVILLE, FLORIDA

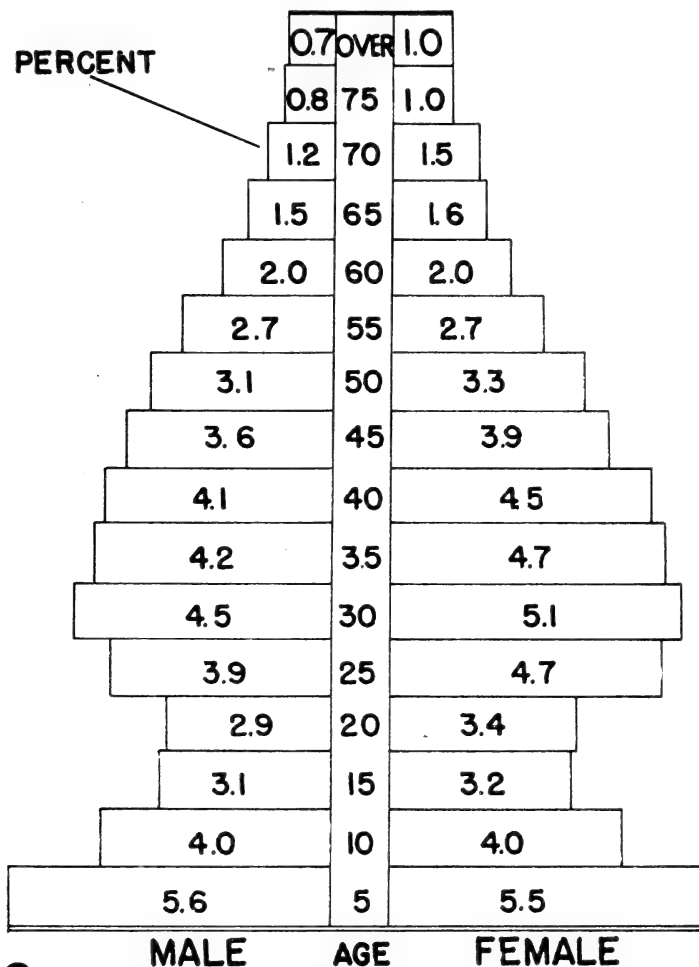

FIG. 2

SOURCE: U. S. CENSUS, 1950, FLA. PB 10

26.8 per cent in the rural farm group while the city of Starke showed a gain of 1,463 or 98.9 per cent (Dietrich, 1954:11, 12).

The population of the county in 1950 was predominantly white, this group comprising 75.6 per cent while the Negro population comprised 24.4 per cent. A breakdown of the county's population in the same year showed that the rural non-farm component accounted for 40.6 per cent. The rural farm group was 33.7 per cent and Starke, the only urban district and county seat, had 25.7 per cent (Saunders, 1953:5). A breakdown of the population for the State and Nation in 1950 revealed that 65.4 per cent and 64.1 per cent lived in urban areas, and 26.1 per cent and 20.7 per cent were in rural non-farm areas, respectively. Florida's population living on rural farms was 8.4 per cent while the Nation had 15.2 per cent in this group (U.S.D.C. Statistical Abstract, 1954:31).

Migration of Population: A salient feature of age-sex composition of Bradford County's population as compared with the State, is the predominance of children under the age of twenty. This ratio is even more pronounced when contrasted with a large urban county of Florida like Duval, with three-fourths of its population in the metropolitan city of Jacksonville.

The age-sex pyramids showing the population of Bradford County and of Jacksonville show clearly the contrast of age groups in 1950 (Figures 1 and 2). Figure 1 shows that 36.4 per cent of the population of Bradford County is under twenty years of age, while Figure 2 indicates only 25.4 per cent is under twenty years of age in Jacksonville (U. S. Census 1950, Fla. P. B-10).

The natural increase in population of a rural county like Bradford is retarded by the out-migration of young people to urban districts for better economic and social opportunities. This is supported by the fact that the birth rate in the county in recent years has averaged 25.0 per 1,000 population, (while the State had 17.5) or 7.5 more per thousand population for the same period with little difference for the death rate for the two groups.

NEGRO POPULATION

The Negro population of Bradford County and Florida has not followed the trends of the South during the last two decades. Some of the trends as well as changes in the Nation's economy are indicated in a remark made recently to a farm group: "The

cotton has gone West, the cattle have gone East, the Negroes have gone North, and the Yankees have come South." Historically, the Negroes in the United States have comprised a rural group; however, if several of the changes that have taken place in recent years in the Negro population of Bradford County and Florida are to be understood, it will be necessary to review some of the migrations of this group in the United States.

PERCENT OF TOTAL POPULATION REPRESENTED BY NEGROES IN FLORIDA, BRADFORD COUNTY AND UNITED STATES

1870 — 1950

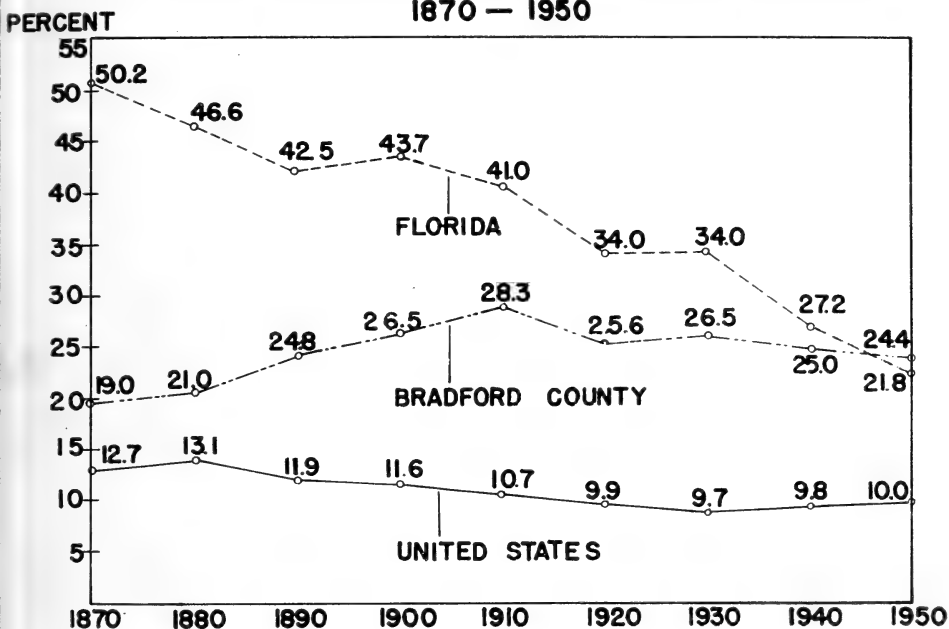

FIG. 3

At the time of the first census in this country in 1790, the proportion of Negroes to whites was one person to every five (19.3 per cent); however, by 1950 this had declined to one person in 10 (10 per cent). This is approximately a 50 per cent decrease in the proportion of Negroes to whites in the last 160 years (Figure 3). It is of interest to note that the total Negro population for the

Nation increased a total of 122 per cent for the period beginning 1870 to 1950 or an annual increase of 1.5 per cent (Trenholm, 1954:22).

The Negroes living on the farms in the South are usually found near the bottom of the scale socially and economically. Most migrations from the farms to urban regions in the South or North appear to be an effort on the part of the Negro to better his lot from the standpoint of income, citizenship, and social standing. The emigration from the southern states of Negroes with a naturally high rate of increase has led to a net decline in the population of Negroes between 1940 and 1950 as follows: Mississippi (8 per cent), Arkansas (11 per cent), Oklahoma (14 per cent), Georgia (2 per cent), and West Virginia (2 per cent). Some of the states with the largest gains in Negro population in this decade, were, New York (60 per cent), Illinois (67 per cent), Michigan (112 per cent), and the District of Columbia (49 per cent) (U.S.D.C. Statistical Abstract, 1954:38). It is significant that those states which received the greatest number of Negro migrations furnished a large percentage of the white emigrants to the State of Florida.

The Negro population in urban districts in the Nation increased from 49 per cent in 1940 to 62 per cent in 1950 or a change of thirteen percentage points. During this same time the Negro population in urban districts of Florida increased 38 per cent while the rural farm Negro population declined 29.1 per cent.

Figure 3 shows that the Negro population of Florida was at its zenith in 1870 when over one-half of the total population (50.2 per cent) was made up of this group (Mayo, 1945:9). It was not until forty years later, in 1910, that the Negro population in Bradford County reached its highest point with 28.3 per cent. By 1950 this percentage had declined to 21.8 per cent for the State, while Bradford County's Negro population showed less than 4 per cent fluctuation during this period.

It is interesting to note that the ethnic trend in urbanization has followed a definite pattern in the State. In 1920 slightly more than one-third of the Negro population (36.6 per cent) and almost the same (36.8 per cent) of the white population lived in cities. In 1950 the same relationship existed with 65.5 per cent Negro population and 65.4 per cent white being urban (Maclachlan, 1953:5). Sixty per cent of the total Negro population of Bradford County lived in the rural non-farm areas in 1950, while 25 per cent

lived in rural farm areas with only 15 per cent living in Starke. This is in contrast with 29 per cent of the white population living in Starke and 34.6 and 36.4 per cent respectively living in rural farm and rural non-farm areas.

Several observations can be made with regard to trends in the Negro population of Bradford County in relation to the rest of the State that need to be borne in mind. *First*, there has been a shift of the rural Negro to urban districts. *Second*, the ratio between Negro and white population has declined in the State while the ratio of Bradford County's Negro group to whites has remained almost constant during the past three decades. *Third*, Negroes average about eight years less in length of life than whites and have a much smaller percentage in the old age (over 65) of both sexes (Dietrich, 1952:22).

SOIL CLASSIFICATION

The Soil Conservation Department of Florida classifies 82 per cent of the land of Bradford County as "flatwoods" or a total of 153,810 acres which includes 6,089 acres under water and 10,771 acres of public land. Less than one-fourth of the soils of the flatwoods are suited to the cultivation of row crops. The Portsmouth and Leon Sands that comprise most of the soils of this group are underlaid with a hardpan which occurs from 18 to 36 inches below the surface (Sellers, 1915:225). This leaves 33,710 acres or 18 per cent that is classified as Middle and Upper Coastal Plain. Some of the most productive soils in the County are found in this classification. The Norfolk Fine and Coarse Sands comprise most of the soils of this group. The soils found along the Santa Fe River and New River are usually classified as bottom lands. There were some 80,971 acres or 43 per cent of the total area of the county in farm lands in 1950. Over two-thirds of these farm lands are devoted to pasture and woodlands.

The forest lands of the County are listed at 144,300 acres or more than three-fourths of the total area of the County. Almost 40 per cent of the remaining one-fourth, *i.e.* 43,220 acres of the land contains soils that are too low and moist for the growing of truck crops and is better suited to pasture and grazing (Gunn, 1954:2). Figure 4 shows an improved pasture on poorly drained land.



Figure 4. White Dutch Clover pasture on a beef cattle farm two miles north of Starke in Bradford County, Florida. Clover is a legume that improves the soil and produces better beef cattle.

In 1930 there were 921 farms which averaged 60.7 acres per farm. By 1950 the number of farms had declined to 736 and had increased in size to an average of 105 acres. Farms in Florida during the past decade have increased in average size from 133 acres to 290 acres, almost three times the size of the average farm in Bradford County. If we examine the land in farms in the small as contrasted with the large holdings some idea can be learned as to how misleading average figures can be. One hundred and twenty-three of the County's farms under 10 acres contain a total of only 626 acres and there are 199 farms with 10 to 29 acres with 3,416 acres. If all farms with from 30 to 49 acres be combined with the two groups above, the total of the three groups would equal 560 farms or 73 per cent of the total farms in the County consisting of only 11 per cent of the total farm acreage. In contrast, the eight farms with over 1,000 acres each contain a total of 33,450 acres or 41 per cent of the total farm area. These eight farms contain more than four times as much acreage as the 560 farms under 49 acres (U. S. Census, 1950: Fla. V. 1-pt. 18).

A number of factors have tended to keep the farms small in Bradford in comparison with the rest of the State. Climate, the

type of soils, and the shortage of labor have all played a part; however, a relatively high percentage of farm owners and the pattern of original settlement have probably exercised considerable influence. The establishment of two farmers' markets in the county and technological changes in farming have helped the farmers to market their produce and has brought some relief from the difficulties arising from the shortage of labor. The number of Bradford County farm owners has increased and the number of share-croppers, tenants, and renters has declined since 1930. During this time the share-croppers and renters have declined from 209 to 54.

Several conditions in the county operate against the farmer making it almost impossible for him to support his family adequately from his farm income. Late frost, poorly drained land, lack of farm machinery, and shortage of capital are all handicaps.

LEVELS OF LIVING

The level of living is assumed in this paper to be the status or position of people relative to others, based on their current consumption or utilization of goods and services, with services being broadly interpreted to include both publicly furnished and privately obtained services which contribute to well-being or provide satisfactions (Hagood, 1944:78).

A study of the "Levels of Living" in Florida by Allen in 1951 (based on data for 1940) estimated the composite indices of Bradford County at 43.7 in which 100 was used as a base for all 67 counties of the State. Better insight as to the county's relative standing in this study can be had by considering the high for Dade County which was 149 and the low of Liberty County which was 23. The five indices included and the rating of Bradford County in Allen's study were: (1) per cent of dwellings with radios (42 per cent); (2) per cent of dwellings with running water and private bathtubs or showers (14.8 per cent); (3) per cent of population age 25 and over who have completed high school (11.9 per cent); (4) number of passenger automobiles per 1,000 population (160.8); and (5) number of persons filing federal income tax returns per 1,000 population (10). (Allen, 1951:30).

Bradford County was in the lowest quartile of number two (sanitation and housing) in this study. The average number of

dwellings in the State with private bath or shower was 54.8 per cent in 1940 which was only slightly less than the U. S. with 56.2 per cent. By 1950 Bradford had increased to 26.2 per cent for this item or a 77 per cent increase while Florida and the Nation increased less than 10 per cent on these fixtures. Bradford County was also low in number three (education) of the above mentioned study with less than 12 per cent of the population above 25 years of age having completed high school. In 1940 the average for Florida for this item was 26.2 per cent while for the U. S. it was 28.1 per cent. The number of homes in Bradford County with radios had increased to 68 per cent and privately owned automobiles increased 50 per cent during the decade 1940 to 1950 (Allen, *loc. cit.*:30).

A more recent study of rural levels of living in counties of the United States has been made by the Bureau of Agricultural Economics, U. S. Department of Agriculture, under the direction of Hagood (1952). Data for 1930, 1940, 1945 and 1950 were used. In this study of rural-farm operators, the four indices were based upon the following: (1) percentage of farms with electricity; (2) percentage of farms with telephones; (3) percentage of farms with automobiles; (4) average value of products sold or traded. This study also used a base of 100 for all U. S. counties for the year 1945.

Bradford County scored higher in the Hagood study of 1950 than in Allen's study for 1940 in relation to other counties of Florida. The rating in the Hagood Study for Bradford County was 37, 40, 48, 65; while Florida rated 45, 53, 76, and 105 for the years 1930, 1940, 1945, and 1950 respectively in the order named. The average for the counties of Florida was about three-fourths of the U. S. average while Bradford County scored only about one-half of the national average which was 75, 79, 100, 122 for the four dates respectively (Hagood, 1952:6, 11, 12).

Education: The average educational achievement for Bradford County was two years below the State average in 1950. The migration of the youths in the county who have finished high school to other regions lowers the educational level of the rural farm and rural non-farm groups. For example during the last decade there was a 2 per cent decrease of those over 25 years of age who had completed high school or one out of ten. One male in twelve had completed high school in 1950 which was one-third less than females with one out of eight. This is very low when compared

with the National average (34 per cent) which showed one out of three graduated from high school. High school graduates over 25 years of age in the city of Starke were more than double the rural farm and non-farm groups in the county but were only half the national average in high school graduates with one out of every six.

In 1950 there were no high school graduates in the Negro rural farm population of the County and only 15 white persons or less than 1 per cent of the total population for this group. In the rural non-farm group there were no Negro High school graduates over 25 years and 190 high school graduates among the whites or 13 per cent.

Perhaps, a better picture of educational training can be had by considering the median number of years completed. The median educational achievement for the population over 25 years of age for the county was 8.1 years in 1950. The white population shows 9.1 years or 3.9 years more than the Negro average for the county with 5.2 years. The average number of years of schooling completed for the Negro for Bradford County is almost two years less than the national average for this group which was 7.0 years. (U. S. Census 1950, Fla. P. B-10). Table I gives the median number of years of school completed and expenditures for white and Negro pupils.

TABLE I

Median number of years completed in school by individuals over 25 years of age and median expenditures per pupil for white and Negro pupils in Bradford County, Florida, ten Southeastern States, and the United States for 1950.

	Median Number of Years School Completed		Median Expenditures per Pupil in Public Schools	
	White	Negro	White	Negro
Bradford County, Florida	9.1	5.2	166.25	166.50
The State of Florida	10.9	5.8	196.42	136.71
Ten Southeastern States *	9.4	5.3	153.60	102.50
The United States	9.7	7.0	224.00**

Source: Trenholm, H. C., Editor, *The Bulletin*, Montgomery, Alabama, May 1954. U. S. Census, 1950, Fla. P, B-10.

* Includes: Mississippi, Alabama, Florida, Georgia, South Carolina, North Carolina, Virginia, West Virginia, Kentucky, and Tennessee.

** Includes all races.

Housing: According to the U. S. Census of 1950, the value of homes in Bradford County is less than one-half of the value of the average home in the State (\$3,036 against \$6,612). The number of homes with running water and indoor toilets is less than 50 per cent of the State average for these items. Only about 25 per cent of the rural non-farm homes have any modern sanitary facilities. Negroes occupy over 60 per cent of the homes in this group, many of which are in rundown condition without screens or sanitary toilets. Lack of sanitation is reflected in the poor health of the white and Negro families. There is a shortage of hospital and medical facilities (Saunders, *loc. cit.*:8).

There were 3,415 housing units in Bradford County in 1950 and they were 90 per cent occupied. A breakdown of the total shows there were 1,423 rural non-farm homes, 1,000 rural farm homes and 992 homes in the city of Starke. In 1950 there were 1,469 white and 391 Negro families that owned their homes in the County while 841 white and 299 Negro families rent their homes. Sixty Negro families owned their homes in Starke and 75 rented. The assessed value of the average Negro homes is slightly over one-half that of the average white homes. (U. S. Census, 1950: Fla. H-A-10).

Another insight into the cultural level can be gained by noting the number of homes with electric washing machines and electric refrigerators. In 1950 there were 2,584 out of a total of 3,415 homes in the county with electric lights and of these 2,460 (over two-thirds) of the homes had radios and 34 per cent owned washing machines while 48 per cent had electric refrigerators (Morris 1953:380). This represents a 50 per cent increase over 1940 for these items. The number of trucks, tractors, and other farm machinery such as potato diggers and cultivators also increased considerably during the last decade.

The almost total absence of running water and refrigerators of any kind for Negroes in the County gives some insight into the low living standards for this group of the county's population. In 1950 there were some 690 Negro dwellings, 21 with flush indoor toilets and only 34 with running hot and cold water including those in the city of Starke.

Income and Employment: The median income for families of Bradford County in 1950 was \$1,373 while the median for the States was \$1,950. Starke families compare favorably in median income with the urban families of the State with \$2,057 and \$2,152

respectively. The median rural farm family of the county had an income of \$1,219 while the State's median income for the same group was \$1,629. The median income of \$1,096 for the rural non-farm group of the county was about two-thirds of the State's median (60 per cent of this group were Negroes).

Three-fourths of the rural families in the county had incomes below \$2,000 while over one-half of the families of Starke had incomes of more than \$2,000 in 1950. The median income for Negro families was \$771 for Bradford County. This was the fourth lowest in the State. By way of contrast, the median income for Negro families in the two urban counties of Dade and nearby Duval was \$1,567 and \$1,485 respectively at the same time. (U. S. Census 1950: Fla. P. B-10). A breakdown of the income for white and Negro families of Bradford County as compared with those of Florida and the United States will be found in Table II.

TABLE II

Median incomes for white and Negro families in Bradford County, Florida, and the United States in 1950.

	White Income	Negro Income
The median income for Bradford County families	\$1,373	\$ 771
The median income for families in Florida	1,950	1,144
The median income for families of the U. S.	2,619	1,350

Source: U. S. Census 1950, Fla. P, B-10.

In Bradford County during 1950, 28 per cent of the people were employed in agriculture, 4 per cent forestry and fishing, 4 per cent in mining, or a total of 36 per cent, while the State had less than 15 per cent in these occupations. There are several small manufacturing establishments in Starke that employ about 8 per cent of the people. They include the following: one clothing, one furniture factory, one lumber mill, and three or four small processing plants of plastics and foodstuffs. The rest of the people are dependent upon trade, service, and professional pursuits except for day laborers on the farms.

The farmers of the county are finding it increasingly difficult to earn their living on the farm. They or some member of their family in about 75 per cent of the homes are employed part or full time in some nearby urban district.

FARMERS' MARKETS

State farmers' markets were established at Starke and Brooker and they have helped in the preparation and sale of farm produce. Figure 5 shows the loading platform and packing facilities of the Farmers' Market at Starke. Truck crops of fruits and vegetables have brought higher prices with this service. The farmers' market in Brooker had sales for the year ending June 30, 1954 of \$163,584 which consisted of the following primary crops named in order of highest sale values: potatoes, string beans, peppers, cucumbers, butter beans, and corn, with an average sale of \$1.32 per hamper, tub or crate.



Figure 5. State Farmers' Market at Starke, Florida. This is one of two State markets for the preparation of farm produce in Bradford County.

Much of the produce of Brooker and Starke is not ready for market until late spring and is sold in competition with other districts in the Southeast. For example, in 1954 cucumbers sold at the Florida State Market in Fort Myers for \$3.22 per bushel in January and February, which was over four times the average price paid at Brooker about sixty days later. The farmers' market at Starke had total sales of \$271,523 which included sales of strawberries amounting to \$88,616 and corn totaling \$81,646. (Lewis, 1954:2, 4, 20). The other important crops sold at Starke in 1954

were cucumbers, pecans, peppers, and peas. The total sale of all farm products of the county for 1950 was \$757,599 which included livestock \$268,584, poultry \$81,202 and forest products \$55,483. (Hurff, 1952:59).

The total retail sales for the county were \$5,645,000 in 1948. This was over four times the retail sales in 1939 which amounted to \$1,398,000 for that year. Since 1950 retail sales have been averaging between six and seven million dollars.

It is of interest to note that only one rural family in three had a milk cow in 1950 which would seem to indicate the lack of milk in the diet of many families. This condition was especially noticeable in most Negro and rural non-farm families. There were also 229 farms that had no mules, horses, or tractors of their own.

LAND TENURE

Since the formation of Bradford County in 1861 several epochs of economic adjustment have influenced the land tenure patterns for the inhabitants. The first saw the building of railroads and the cutting of dense virgin forest which was followed by heavy migration of white farmers and Negro settlers from Georgia, South Carolina, and Alabama after the "War Between the States". Some came to avoid the "carpet baggers", for Florida was scarcely involved in the struggle. The lure of new land appealed to others. Land speculations and the planting of orange groves brought northern capital and settlers during the second epoch which ended with the "Big Freeze" in 1895-6. People from the Chicago area settled at Lawtey and Starke. Following the "Big Freeze", the land was returned to the growing of cotton, corn, and peanuts during the first three decades of the 1900's. This might be termed the third epoch.

The man-land ratio has undergone several major changes in Bradford County, following the depression of the 1930's, forming a fourth epoch. Citrus and general farming proved unsatisfactory and man resorted to new technological improvements to earn his livelihood from the soil. Truck farming, beef cattle, and forest products have been the latest developments in the age of commercial and specialized farming.

The in-roads by the paper, lumber, and chemical companies is shown by the purchase, or long term lease, of large blocks of land. Few if any residences are found in these tracts of land. Most of

the pulp, paper, and chemical companies operating in Bradford have home offices outside of the state. Personal interviews with local residents indicate that there is concern as to whether these corporations will continue as others have in the past to follow a "cut out and get out" policy or use sound long range conservation programs. Corporations are often market-minded and commodity-conscious; their interests are often limited to the short runs. There is a natural tendency to think of the present profits. Frequently in the past the health, educational, and the social needs of society have been somewhat neglected by business.

Will corporation management in Bradford County make wise use of conservation practices of the land for present and future forest needs? Will they use a part of their profits to help rehabilitate the white and Negro farm families by transferring them to the more productive farm lands of the county? If so, corporation skill and capital should be a stimulation for future progress in the county. Long term leases for forest lands appear to offer better possibilities for all concerned for income to the county and population growth rather than outright sale of land and timber by farm families.

IMPLICATIONS FOR FUTURE EDUCATION

There is little doubt that the problems raised in this study have grave implications for the welfare of not only Bradford County but also for Florida and the Nation as well. The rural white population lacks the skill, education, and capital to meet the problems of education, housing, health, and poverty among themselves. The same is true of the Negro families who are even more unfortunate. Lack of planning and loss through emigration of the physically stronger and more mentally able young people to the urban regions offer little hope for the improvement of those left behind, in a social, economic, physical, mental, and spiritual way.

Many farm families short of income have resorted to commercial farming or the growing of cash crops, while neglecting the diet of their families. This is evident by the fact that only one out of three rural families owns a milk cow and 299 farm families own no horses, mules, or tractors but must hire or rent them.

It is estimated that the typical farm family in Bradford County would need more than double the present average size farm of 105 acres to support his family adequately. This would make it

possible for him to be employed the year round on the farm and permit him to obtain a good balance between cash crops of fruits, vegetables, hay, and pasture for his livestock. This would also allow approximately one hundred acres of land to be utilized in forest on a long-range sustained-yield basis for timber, pulpwood, or naval stores.

Good transportation facilities and a surplus of labor should encourage some further light manufacturing to locate in or near Starke. Development of further tourist facilities with roadside stands of fruits and vegetables should help increase the County's income along U. S. Highway 301. The above improvements would increase the use of the County's resources but would not solve the rural farm problems.

Educational planners and leaders in governmental agencies should focus their attention and assistance upon the well-being of our white and Negro families living in rural counties like Bradford. All of our people should come to realize that much of our nation's economy and future well being is dependent upon the health, education, and welfare of a stable farm population because it is the producer of the basic commodities upon which much of our economy is dependent. Some way must be found to impart to our rural people the knowledge, understanding, and facts now available to research workers. No doubt better planning and training of local leaders through action programs would help.

To anticipate the extent, intensity and implication of problems of economic, social, and human adjustment in a rural county such as Bradford will require that specialists in education, social engineers, and economists undertake careful studies.

SUMMARY AND CONCLUSIONS

Bradford County is basically agricultural; less than 8 per cent of the population is employed in manufacturing, 4 per cent in fishing and forestry, and 4 per cent in mining. The farms in the county have been kept small because of the types of soil, the shortage of labor, and the types of crops grown. The high percentage of farm owners and the pattern of original settlement have probably exercised considerable changes in farming. In addition, improved roads and transportation have made it possible for farmers to have better markets for their produce.

The farmers are finding it increasingly difficult to support their families because of the small sizes of the farm, delay in the planting of truck crops, uncertain prices for produce, lack of capital, and high prices that must be paid for home and farm equipment.

The high natural increase in the County's population has been offset by the out-migration of young people to urban districts for better economic and social opportunities. Emigration is especially high among the Negro young people; their families' income averaging only one-half of the County's as a whole, or 23 per cent of the national average.

Conditions of sanitation, health, diet, recreation, and education are sub-standard for white rural families and are even lower for the Negro families living in rural or urban districts. Only one person in ten in the county over 25 years of age has graduated from high school. Less than 1 per cent of white people and no Negroes over 25 years of age living on the farm have finished high school. The median years of school completed for Negroes is 5.2 years which is less than two-thirds of white population with 9.1 years. Poverty, poor health, and lack of education are prime factors that are retarding further progress of the white and Negro races in the County.

From the foregoing data and analysis of Bradford County it can be concluded that (1) the farm population is declining (26.8 per cent from 1940 to 1950), (2) the use of land is changing, (3) agricultural products of greater cash and real value are being produced. Other trends that will probably influence future developments of the county included the mechanization of agriculture, the increase of improved pasture and forest land, the reduction of acreage planted in cultivated crops, and the increase in size of farms and land holdings. The declining rural farm population suggests the need for each rural community to reappraise its economic, educational, and social problems periodically. The leaders of educational institutions, civic groups and community betterment organizations in a rural county like Bradford must assume the responsibility to meet the needs of a changing population. The decline of farm population and migration to urban districts of young people from farms suggests four types of community planning: *First*, the curriculum of the secondary schools must be designed to prepare the farm boys and girls to enter non-agricultural pursuits. *Second*, the use of cooperative leadership by industrial management, plan-

ning commissions and educators must provide for the transition of a declining rural farm population. *Third*, there is the need for immediate and long range employment of farm youth in non-agricultural pursuits. *Fourth*, ways must be found to help farmers to become more efficient producers and to obtain a larger share of the income from agricultural commodities produced on the farm.

LITERATURE CITED

ALLEN, FRANCIS R.

1951. *Levels of Living in Florida Counties*. Fla. St. Univ., Soci. Sci. Bul. No. 2:30, 31.

BECKER, HENRY

1954. "Florida's Resource-Use Problems", *Quart. Journ. Fla. Acad. Sci.* 17(2):73-76.

BRADFORD COUNTY TELEGRAPH

1954. 75th Anniversary Ed., No. 12, Sec. 4, pp. 4-6, Starke, Fla.

DIETRICH, T. STANTON

1952. *Florida's Older Population*, Fla. St. Improv. Com., Tallahassee, Fla., Res. Rep. No. 2:22-26.

DIETRICH, T. STANTON

1954. *Statistical Atlas: Florida's Population: 1940 and 1950*. Fla. St. Univ.; Soci. Res. Lab., Res. Pep. No. 3:11, 12.

FLORIDA STATE CHAMBER OF COMMERCE STATISTICS

1944. *Abstract of Florida Counties, Jacksonville, Fla.*, pp. 1-10.

GUNN, COLIN

1954. *Soil Conservation Service Report, Bradford Co.*, Gainesville, Fla., pp. 2-3.

HAGOOD, MARGARET J.

1944. "What Levels of Living Indexes Measure," *Am. Soc. Rev.* Vol. IX:78-80.

HAGOOD, MARGARET JORMAN

1952. *Levels of Living Indexes of Farm-Operator-Family of the United States*, U. S. Dept. of Ag., Bur. of A. Ec., Washington, D. C., pp. 1-30.

HURFF, GEORGE B.

1952. "Retail, Wholesale and Service Trades in Florida." *Bur. of Eco. and Bus. Res.*, Univ. of Fla., 59:3-46.

LEWIS, L. H.

1954. *Florida State Farmers' Markets*, 20th Ann. Rep., Winter Haven, Fla., pp. 1-44.

MACLACHLAN, JOHN H.

1952. "Florida's Population 1920-1950," *Public Administration Clearing Service*, Univ. of Fla., pp. 3-8.

MAYO, NATHAN

1945. *The Seventh Census of Florida*, Dept. of Agric., Tallahassee, Fla. pp. 5-141.

MORRIS, ALLEN

1953. *Florida Handbook*, the Peninsular Pub. Co., Tallahassee, Fla., pp. 380-385.

SAUNDERS, JOHN VAN DYKE

1953. "Preliminary Report of the Bradford County Survey" (unpublished), Univ. of Fla. *Department of Soc.*, Gainesville, Fla., pp. 5-8.

SELLERS, E. H.

1915. *Florida Geological Survey*, Tallahassee, Fla., p. 225.

TRENHOLM, H. COUNCIL

1954. Ed., *The Bulletin*, Montgomery, Ala., 29:12-28.

UNITED STATES DEPT. OF COM.

1954. *Statistical Abstract of the United States*, U. S. Gov. Print Office, Washington, D. C., pp. 31-62.

U. S. BUREAU OF THE CENSUS

1950. *Population Census Report*, Florida. U. S. Dept. Com., Washington, D. C., P. B-10:14-60, Fla. H-A-10:10-31, Fla. V-1, Pt. 18:8-26.

REVIEW OF THE GENUS DOLDINA STAL
(Hemiptera: Reduviidae)

ROLAND F. HUSSEY¹ and JOE C. ELKINS²

Doldina Stal, 1859, is a new-world genus pertaining to the tribe Zelini of the subfamily Harpactorinae. Most of its species are quite similar in size and general habitus. They are slender, usually parallel-sided forms, averaging 16 to 17 mm. in length, with bodies six to eight times as long as wide, with the pronotum lightly declivent anteriorly, and with a porrect, more or less cylindrical head which commonly is about twice as long as wide across the eyes. In dorsal view the head gradually narrows toward the base, becoming about one-fourth narrower there than at or just behind the ocelli; in side view it appears almost uniformly thick, with dorsal and ventral surfaces subparallel, nearly to the base where it is abruptly coarctate (especially below) to form a short neck. There is a dorsal spine at the base of each antenniferous tubercle, longer than the vertical height of an eye in one or two species, somewhat shorter in some others, and reduced almost to the point of obsolescence in a few species.

The pronotum is gradually narrowed toward the front, the anterior angles are thick and blunt, and the anterior margin between them is deeply, roundly emarginate. The two lobes are separated by a shallow sulcus; the anterior one is commonly smooth and more or less shining, the posterior one commonly is closely but not deeply punctate. The posterior lobe, like the abdominal margin, varies greatly in its armature in different species. Sometimes it bears a pair of discal spines and a pair of lateral spines above the humeri; in other species the discal pair alone, or both pairs, may be greatly reduced or entirely absent, but no discal spines are ever found unless lateral spines are also present. In some species marginal spines occur on all the connexival segments (five in males, six in females), while in others they may be restricted to the first three, the first two, or even the first segment alone. In these latter cases the next following segment may have its apical angle acutely prominent, in the form of a small tooth rather than a spine; and

¹ University of Florida, Gainesville, Florida.

² American Optical Co., Instrument Division, Atlanta, Georgia.

sometimes individuals are not symmetrical in this respect on the two sides of the body.

The front and hind legs are long, the middle ones notably shorter, and though the femora are not spinose beneath, they all are armed with a small but distinct apical spine on each side. The middle legs often have both femur and tibia lightly curved downward, and the front femora of one species have a slight bisinuous lateral curvature. The front femora and tibiae are provided with short, dense pubescence on the entire length of the ventral surface. In addition, all the legs, the antero-ventral part of the prothorax, the sides of the head (especially behind the eyes), and the first antennal segment bear much longer pilosity whose density differs in the various species.

In generic keys *Doldina* is coupled with *Ricolla* Stal, as they are the only American Zelini whose femora are spined at the tips. This is a rather superficial character, and the true relationships of *Doldina* may possibly be elsewhere. The species of *Ricolla* are more robust and less elongate, with the abdomen more definitely widened behind the middle, and the head in side view tapers gradually toward the base. There is some resemblance between *Doldina* and *Debilis* Stal, but the latter has a shorter and differently formed head, the costal margin of the corium is concavely sinuate (which is rarely seen in *Doldina*), and the post-scutellum is separated from the scutellum: *Debilis* possibly is closer to *Lindus* Stal and *Socius* Champion. Some species of *Heza*, too, superficially resemble *Doldina*, but they are at once distinct by possessing the small mesopleural tubercle characteristic of members of the tribe Harpactorini. A comprehensive study of the entire tribe Zelini will be necessary to determine the phylogenetic relationships of *Doldina* and its allies with any certainty.

The more robust form of *Doldina lauta* (Stal) and its somewhat more declivent pronotum may perhaps have been among the factors which led Stal (1862) to erect the genus *Hygromystes* for it, though in subsequent keys (1866) he used only the spinose or non-spinose nature of the pronotum to separate *Doldina* and *Hygromystes*. In his last work on American Reduviidae (1872), he treated these two taxa as subgenera, employing the junior name *Hygromystes* for the combined genus. Bergroth (1913), approving this consolidation, restored the senior name *Doldina*, and described a new species which he stated to be "exactly intermediate in structure

between the subgenera." Fracker and Bruner (1924), overlooking Bergroth's paper, redescribed this species under another name and proposed a new subgenus *Ceballum*, in *Hygromystes*, for the intermediate category. Blatchley (1926) quite properly rejected all subgenera in *Doldina*. In our opinion the characters on which they were based have no more than specific value, and indeed they vary somewhat even within some of the species.

Wygodzinsky (1949) catalogued seven species of *Doldina*. Two of these are here synonymized with others, and two new species are described. The species are predominantly neotropical in their distribution. In the North American material examined we can recognize only a single species, most common in the Gulf states but ranging northward along the coast at least to North Carolina (to Maryland, according to Van Duzee, 1917) and southward to Cuba, Isle of Pines, and Honduras.

Little has been published regarding the habits of *Doldina*. Blatchley (1926) found *D. interjungens* "frequent on tall dead grasses along the borders of ponds, lakes, and the sloughs of the Everglades," and certainly the type of this then undescribed species was one of the two specimens of "*Hygromystes* sp." that Torre-Bueno and Engelhardt listed as taken on sedges back of the beach at Roanoke Island, North Carolina. Barber and Bruner (1937) said this same species was taken in Cuba by sweeping coarse, dry grasses in old fields. Also, they listed it from one locality more than 2,500 feet above sea level, but it seems to be primarily a lowland species. Elkins (1951) said that in Texas it is "abundant along the Gulf," though occurring elsewhere in the state, sometimes being found on trees; and in Texas and Louisiana it has been reported as coming to lights (Elkins, 1951; Sibley, 1951).

Dr. T. H. Hubbell, Director of the University of Michigan Museum of Zoology, has most kindly furnished us field data on numerous specimens of *D. interjungens* taken by him in Florida and Louisiana. Most of them were collected from grasses in or bordering salt marshes, often at night, when they were found by sweeping or by searching with a head-light. Others came from grasses and sedges bordering fresh-water lakes or from fresh-water marshes, and a few were swept from grasses in palmetto-scrub fields at night or were taken at lighted sheet.

Some specimens of *Doldina bicarinata* from Panama, in the U. S. National Museum, are labelled "sweeping around cornfields," others

"from grass and cowpeas." Dr. Wygodzinsky, when he visited Florida in 1955, told us of having found *Doldina* commonly on marsh grasses near Rio de Janeiro.

We wish here to express our thanks to the several individuals and institutions who have loaned us material or have furnished us information regarding specimens in collections under their care. These are Dr. R. I. Sailer (U. S. National Museum), Dr. H. Ruckes (American Museum of Natural History), Dr. H. Dietrich (Cornell University), Dr. H. V. Weems, Jr. (State Plant Board of Florida), Dr. G. E. Wallace (Carnegie Museum), Dr. T. H. Hubbell (University of Michigan Museum of Zoology), Dr. E. S. Ross (California Academy of Sciences), Dr. S. von Keler (Museum of the University of Berlin), Dr. J. Maldonado Capriles (University of Puerto Rico), Ing. F. Valdes Barry (Estación Experimental Agronómica, Santiago de las Vegas, Cuba), and Dr. R. Malaise (Naturhistoriska Riksmuseum, Stockholm). We are especially indebted to the last-named for the privilege of examining type material of two species described by Carl Stal.

Genus *Doldina* Stal

Doldina Stal 1859: 366 [in key] and 368 [diagnosis] [monobasic; haplotype *D. carinulata*, new species]; Stal 1866: 292 and 296; Stal 1872: 78 [as subgenus of *Hygromystes*]; Bergroth 1913: 263; Van Duzee 1917: 266 [catalog]; Blatchley 1926: 567 and 580 [diagnosis, erroneous in part, based on one North American species]; Readio 1927: 168 and 202 [translation, erroneous in part, of Stal's original diagnosis]; Wygodzinsky 1949: 38 [catalog].

Hygromystes Stal 1862: 75 [monobasic; haplotype *H. lautus*, new species]; Stal 1866: 292; Stal 1872: 68 and 78; Fracker and Bruner 1924: 172 [subgenera characterized]; Bruner 1926: 71 [in key].

Ceballum Fracker and Bruner 1924: 172 [as subgenus of *Hygromystes*] [monobasic; haplotype *Hygromystes (Ceballum) armatus*, new species]; Bruner 1926: 71; Blatchley 1926: 580, note 70 [as synonymous with *Doldina*].

1. *Doldina cubana* Barber and Bruner

Doldina cubana Barber and Bruner 1946: 56, figs. 2-4 [♂; Veguita, Oriente Province, Cuba; type in U. S. National Museum]; Wygodzinsky 1949: 38.4.

The characters used in the key below to separate this species from *D. bicarinata* are drawn from the original description and the figures given by the authors. *D. cubana* is known only from the type specimen, and it is the only species of *Doldina* that we have not seen.

2. *Doldina bicarinata* Stal

D[oldina]. bicarinata Stal 1866: 296.1 [♀; "Brasilia borealis," in Stockholm Museum]; Barber and Bruner 1946: 58; Wygodzinsky 1949: 38.2.

H[ygromyastes]. (Doldina) bicarinata, Stal 1872: 78.1.

This species shows the highest development of spines that we have seen in the genus. The post-antennal spines are longer than the vertical height of an eye, the pronotal spines (both discal and lateral) are longer still, and all the connexival segments bear spines which commonly decrease in length posteriorly, the last pair being less than half as long as the first pair. Pilosity of the body parts is relatively thin and short, few of the hairs being longer than the dorsal width of an eye. The specimens we have seen range from 14.6 to 17.3 mm. in length.

Male. Ventral rim of the genital fossa turned outward at posterior apex (Fig. 1), forming a slight, blunt prominence beyond dorsal apex and foreshadowing the condition figured by Barber and Bruner for *D. cubana*; median process of hypopygial margin subvertical, slender, very slightly tapering from base to middle, thence subparallel, extreme tip reflexed.

This is a common species in Panama, judging from the number of specimens examined, and it ranges southward as far as Paraguay. We have seen material from the following localities:

PANAMA: Juan Mina Citrus Plantation, 3♂, 3♀; Flat Rock Plantation, Chagres River, 1 mile above Juan Mina, 3♂, 3♀; Limon Plantation, 2♂, 1♀; Barro Colorado, 1♀; Tabernilla, 1♂ (U.S.N.M.). "Panama," 1♀ (Carnegie Mus.).

COLOMBIA: Palmira, Dept. Valle del Cauca, 3 exx. (Maldonado Capriles coll.); Palmyra, 1♀, "Colombia," 1♀ (U.S.N.M.).

BRASIL: Corumbá, Mato Grosso, lowland, March, 1♂, 3♀; Rio Purús, Hyutanahan, 1♂ (Carnegie Mus.).

PERU: Tingo María, 2200 ft., 1♀ (Amer. Mus. N. H.).

PARAGUAY: Villeta, 1♂ (Carnegie Mus.).

3. *Doldina carinulata* Stal

D[oldina]. carinulata Stal 1859: 368.1 [♀, "Brasilia," in Berlin Museum]; Stal 1866: 296 [comparative notes]; Barber 1923: 28 [as "*D. carinulatus*"; Wygodzinsky 1949: 38.3 [catalog].

H[ygromyastes]. (Doldina) carinulatus, Stal 1872: 78.2.

Doldina antiguensis Barber 1923: 28 [NEW SYNONYMY] [δ ; Antigua, in American Museum of Natural History]; Barber and Bruner 1946: 58 [as "*D. antiquensis*," comparative notes]; Wygodzinsky 1949: 38.1 [catalog].

Dr. S. von Keler, in correspondence, informs us that the unique female type from which Stal's original description was drawn is not now in the Berlin Museum. However, we have received a male from the Stockholm Museum whose pin bears the following items: (1) a label with the word "Amazon" in faded handwriting; (2) a printed label, "Stevens;" (3) a label with "*carinulata* Stal" in Stal's handwriting; (4) a printed label, "TYPUS," on heavy red paper; and (5) a pink label with the printed number "173" and a handwritten number "53." Except that it is a male, and that all four pronotal spines are equally long, this specimen conforms well with the original description. Since the holotype of *D. carinulata* seems no longer to be extant, this male may be accepted as neotype of the species.

This is another wide-ranging species, occurring from the Lesser Antilles to Paraguay. It agrees in size with *D. bicarinata*, but is readily separable from that species by the shorter cephalic spines (only half to two-thirds as long as the height of an eye), by the presence of spines on the first three connexival segments only, and by the terminal structures of the abdomen, among other characters. There is a strong tendency for individuals of this species to become suffused with red, particularly on the legs, antennae, dorsum of head, and to a much lesser degree on the corium; and the dorsum of the abdomen often has conspicuous bright red longitudinal streaks. The costal margin of the corium is more distinctly sinuate than in other species of *Doldina*.

The thoracic spines vary greatly in *D. carinulata*. The lateral spines are well developed as a rule, though shorter than in *D. bicarinata*, and the discal spines may be as long as the lateral ones. Often, however, they are somewhat shorter. The greatest reduction we have seen is in a Venezuelan specimen whose lateral spines are as small as in many *D. interjungens* and whose discal spines are subhorizontal, concolorous, and so small as easily to be overlooked. Such specimens can be separated from *interjungens* by the more widely depressed postero-lateral margins of the pronotum and the lobulate posterior angles, by having spines on three connexival segments instead of two, and by the genital characters. As the specific name indicates, the pronotal carinulae are usually

more distinct here than in other species, with one on the lateral margin of the posterior lobe and two each side on its disk anteriorly.

Dr. Herbert Ruckes has very kindly compared for us the type of *Doldina antiguensis* Barber with a male which we had identified as *carinulata* by comparison with the neotype. He reports that *antiguensis* is at most only a minor variant of the present species, with the posterior lobe of the pronotum a trifle longer, its carinulae somewhat less conspicuous, and with all three connexival spines equally long, but with genitalia apparently identical.

Male. Genital capsule with a narrowly thickened posterior margin, the hind edge transverse; posterior median process a slender spine, slightly triangularly widened at very base, extreme tip reflexed, barb-like; claspers relatively short and thick, their tips (in posterior view) separated from median process by less than their own thickness.

Female. Pygidium subvertical, bent backward on apical half, apex not or very slightly caudad of the lightly produced apex of 8th tergite.

The material before us is from the following localities:

WEST INDIES: Dominica, B.W.I., 2 ♀ (U.S.N.M.).

BRITISH GUIANA: Plantation Drill, 1 ♀ (U.S.N.M.).

VENEZUELA: Tacarigua, Mérida State, 1 ♂ (U.S.N.M.). Puerto Cabello, 1 ♂ (Calif. Acad. Sci.).

BRASIL: "Amazon," ♂ neotype as noted above (Stockholm Mus). Santarem, State of Para, 1 ♂ (Carnegie Mus.). State of São Paulo, Ilha Seca, 1 ♂, and Onda Verde, Fazenda São João, 1 ♂ (exchange from Instituto Oswaldo Cruz). Chapada, State of Mato Grosso, 3 ♂, 3 ♀ (Carnegie Mus.).

PARAGUAY: Horqueta, 1 ♂, 1 ♀ (Van Duzee collection in Calif. Acad. Sci.).

4. DOLDINA LIMERA, new species

Length, ♂, 15.8 mm., humeral width 2.1 mm.

Pale testaceous; membrane hyaline, with numerous rather large fuscous spots inside closed cells and some faint brownish markings outside them; hind femora lightly spotted with brown; connexival segments, above and below, with a small piceous spot in outer apical angle, spots of last two segments becoming linear;

abdominal dorsum with a broad brown median stripe, interrupted at most segmental incisures, with irregular longitudinal lines of black and red each side of median stripe, and with a submarginal row of large, round, brownish spots, one at middle and one at hind margin of each segment. Male genital segment with a few blackish spots.

Head, including neck, slightly longer (257:246)³ than its humeral width, and about two-fifths as wide anteriorly (87:209) as across humeri. Posterior margin transverse before scutellum, posterior angles obtusely rounded, not at all produced backward as lobules, postero-lateral margins not sinuate; supra-humeral spine minute (0.07 mm. long), discal spines represented by minute black conical tubercles. Scutellum much longer than wide (140:96), its Y-shaped tumid area triangularly impressed at about mid-length of scutellum. Outer apical angle of first connexival segment with a small, blunt-tipped, digitiform spinule, second segment with only a small callose node, both of these piceous-brown. Median posterior process of hypopygial margin (Fig. 2) horizontal, directed forward, spatulate, a little broader at middle than at base, very plainly grooved on upper surface, extreme tip reflexed. Internal genitalia not dissected.

Female unknown.

Holotype, ♂, Bonito Province, Pernambuco, Brasil, 2-4-83, in the P. R. Uhler collection, U. S. National Museum.

Readily separated from all known species of *Doldina* by the maculations of the membrane, the hind femora, and the connexival angles, as well as by the position and form of the male hypopygial process. No other *Doldina* has been seen with such greatly reduced spines on the first connexival segment.

5. *Doldina lauta* (Stal)

Hygromystes lautus Stal 1862: 75.1 [♂, ♀; Rio de Janeiro, in Stockholm Museum and Stal collection].

H. (Hygromystes) lautus, Stal 1872: 78.3.

Doldina lauta, Wygodzinsky 1949: 38.6 [catalog].

This seems to be an uncommon species, as there are only four specimens in the material we have examined, one of these being

³ Unless otherwise stated, all measurements are in hundredths of a millimeter.

Stal's female cotype. It is larger and more robust than the other *Doldina* species (though some females of *D. interjungens* are quite as long), the pronotum is slightly more declivent, and the anterior femora show a slight but distinct bisinuous lateral curvature in both sexes. The post-antennal spines are small, the pronotal disk is unarmed, and only one specimen (the male) has as much as a small tubercle at the site of the lateral spine. The first two connexival segments are spined. The hemelytra slightly surpass the abdomen.

Male. Genital capsule about one-fifth narrower than the fossa formed for its reception by the seventh sternite, unique in *Doldina* in having a deep, linear, median, longitudinal impression from base to about the middle, also with a shallow transverse impression shortly before the apical margin. Median process of hypopygial margin directed obliquely forward and upward, its sides subparallel on basal three-fourths of its length, then curved backward so that the apical portion is nearly vertical, postero-dorsal side shallowly grooved at base; claspers very short and thick, failing by nearly their own length to reach the median process.

Female. Pygidium flat, vertical, not reflexed on apical half, overhung by 8th tergite whose posterior margin is roundly and broadly produced very distinctly caudad of apex of 9th tergite.

We have seen the following material:

BRASIL: Rio de Janeiro, 1 ♀ (cotype of Stal, in Stockholm Museum). Lassance, Minas Gerais, 1 ♀ (U.S.N.M.). "Entre Rios, Brazil," 1 ♂; Rio de Janeiro, 1, multilated (Carnegie Mus.).

Several places in Brasil formerly were known as Entre Rios. Since this male bears the same accession number as specimens taken at Chapada and Corumbá, the locality in question would seem to be the one now known as Rio Brillhante, in the state of Mato Grosso not far north of the Paraguayan border.

6. DOLDINA PENALEA, new species

Length, ♂, 16.4 mm., humeral width 2.0 mm.

Pale yellowish testaceous or stramineous; head with a faintly reddish vitta behind each ocellus, reaching base of head; front lobe of pronotum with lateral margins lightly embrowned; a broad longitudinal stripe on corium and sides of venter sometimes lightly suffused with reddish; membrane hyaline, unspotted; apical

fourth of posterior femora either lightly infuscated or slightly tinged with reddish; abdominal dorsum with a brown median vitta, more or less interrupted at segmental incisures, and with a narrower sublateral vermilion streak each side.

Head, including neck, about four-fifths as long as pronotum on median line (239:274) and more than twice as long as its own transocular width (239:104); posterior lobe one-seventh longer (128:112) than anterior lobe measured to tip of tylus; eyes less than half as wide in dorsal view (25:54) than minimum distance between them, ocelli slightly nearer to one another (49:54) than the inter-ocular distance; pre-ocular length of head, seen from side, to tip of tylus two-thirds the post-ocular length (76:113) and one-half greater than length of eye (76:50), tylus surpassing antenniferous tubercles by about thickness of first rostral segment. Cephalic spines small, triangular, subconical, not longer than diameter of ocellus. Lengths of antennal segments I:II:III = 772:205:528, fourth segment approximately twice as long as second, first segment one-fourth longer than head, pronotum, and scutellum combined, with thick erect silvery pilosity, hairs on basal fifth twice as long as thickness of segment, becoming progressively shorter and somewhat more oblique on distal part, those near tip shorter than thickness of segment; second segment much less pilose, third with short, semi-appressed pilosity only. Head, except gula, with short, sub-appressed pilosity, and also (except dorsum of posterior lobe) thickly clothed with long, often curved, silvery hairs, some of which are nearly as long as distance between eyes.

Pronotum one-third longer on median line than its transhumeral width (274:204); anterior lobe two-fifths shorter than posterior lobe (102:172), impunctate, with a short, deep, median longitudinal impression behind middle; posterior lobe closely concolorously punctate, median longitudinal groove broad, shallow, almost obsolete, extending forward to transverse sulcus and there bordered at each side by a short, low carinula which extends to posterior fourth of anterior lobe; discal and lateral spines entirely wanting; posterior margin virtually straight, transverse, posterior angles minimally extended backward, postero-lateral margins straight, oblique; interlobular sulcus tri-sinuate on each side of median line, interrupted only by the paramesal carinulae. Scutellum $5/7$ longer than wide at base (120:76), lightly depressed basally at middle between arms of a Y-shaped subcallose ridge; extreme tip not recurved. Heme-

lytra nearly reaching apex of abdomen (♀) or very slightly surpassing it (♂).

Front femora nearly one-third longer (650:500) than head and pronotum conjoined, one-half thicker than middle or hind femora, slightly longer than front tibiae; middle femora one-third shorter (500:675) than hind ones; all femora and tibiae quite thickly set with erect silvery hairs about as long as thickness of front femora, front legs also with very short, dense, erect pubescence beneath as in other species of *Doldina*.

Male. Median process of hypopygial margin, seen from behind, a very slender erect spine (Fig. 3). Internal genitalia: basal plate moderately robust, with anterior bridge (Fig. 5); aedeagus when retracted mostly covered by basal plate (Fig. 7); everted endosoma (Fig. 6) with two club-like small conformities at dorsal mid-portion, these and several posterior areas of endosoma with many tiny spines on surface.

Female. Eighth tergite broad, twice as wide across base (including connexivum) as its median length (Fig. 4); apex of abdomen with rather long pilosity, partly or largely concealing the oblique pygidium.

Holotype: ♂, Rio Paulaya, El Dorado (Departamento Colón), Honduras, April 16, 1923 (T. H. Hubbell), in University of Michigan Museum of Zoology; collected from a rather small, dry, sedge marsh in an open forest of Caribbean pine and oaks. Paratypes, 2 ♂, taken with the type, in University of Michigan Museum and Hussey collection. Other paratypes as follows:

HONDURAS: 1 ♂, Rio Clauro, Depto. Colón, April 18, 1923, taken beside a trail through lowland selva forest (T. H. Hubbell); Puerto Castilla, March 23, 1924 (J. Becquaert); both of these in Univ. Mich. Museum.

BRITISH HONDURAS: Punta Gorda, Feb. 1931, 1 ♀ (J. G. White), in Elkins collection.

EL SALVADOR: Porillo, Santa Cruz, July 9, 1953, 1 ♂ (Salazar); same locality, Dec. 21, 1953 (M. S. V.), 2 ♂; in U. S. National Museum.

NICARAGUA: Corinto, Jan. 26, 1930, 1 ♀ (T. O. Zscholke), in California Academy of Sciences.

ECUADOR: Guayaquil, 1941, 2 ♀ (C. L. Fagan), in U. S. National Museum.

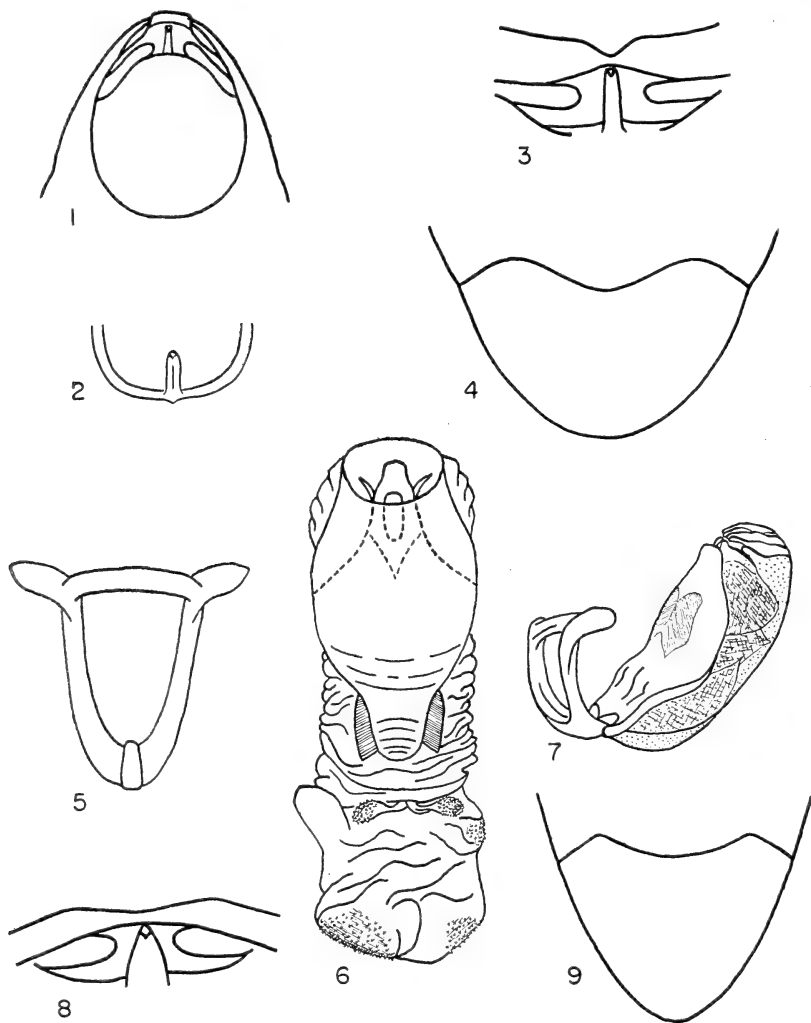

EXPLANATION OF FIGURES

1. *Doldina bicarinata*, male, apex of abdomen, ventral aspect.
2. *D. limera*, male, hypopygial margin and median process, dorsal aspect.
3. *D. penalea*, male, apex of abdomen, posterior aspect.
4. *D. penalea*, female, eighth abdominal tergite.
5. *D. penalea*, basal plate.
6. *D. penalea*, everted endosoma, dorsal aspect.
7. *D. penalea*, retracted aedeagus.
8. *D. interjungens*, male, apex of abdomen, posterior aspect.
9. *D. interjungens*, female, eighth abdominal tergite.

This species most closely resembles *D. bicarinata* in the structure of the male genital segment, both species having the apex of the last tergite rather deeply notched above (Fig. 2), and both have quite similar spine-like median processes on the hypopygial rim; yet these two species represent the two extremes as regards the development of body spines within the genus. *D. penalea* lacks all thoracic spines, the connexivum bears spines on the first segment alone, and the cephalic spines are extremely small. Also, the present species is probably the most pilose of them all, with the long erect hairs of the hind tibiae quite thickly placed on its basal two-thirds, with the first antennal segment much more pilose than in most *Doldinas*, and with a more pronounced comb of long hairs, many of them curved, on each side of the head behind the eyes. The individuals seen range from 15.8 to 17.2 mm. in length.

7. *Doldina interjungens* Bergroth

Hygromystes sp., Torre-Bueno and Engelhardt 1910: 150 [listed, Roanoke Island, N. C.].

Doldina interjungens Bergroth 1913: 263 [♀; Roanoke Island, N. C., coll. by Engelhardt, in Torre-Bueno collection]; Van Duzee 1917: 267.794 [catalog]; Blatchley 1926: 580.555 [redescribed; *D. praetermissa* Bergroth as new synonym]; Readio 1927: 203 [Bergroth 1913 quoted in full]; Bruner and Barber 1937: 188 [with *D. armata* (F.&B.) as new synonym]; Brimley 1938: 73 [listed only]; Wygodzinsky 1949: 38.5 [catalog]; Sibley 1951: 92.44; Elkins 1951: 409.

Doldina praetermissa Bergroth 1913: 264 [♀, Charlotte Harbor, Fla. (Mrs. Annie Trumbull Slosson), and ♀, Belize, British Honduras (C. F. Baker)]; Barber 1914: 506; Van Duzee 1917: 267.793 [catalog]; Barber 1923: 29; Blatchley 1926: 581 [as synonym of *D. interjungens*]; Readio 1927: 203 [Bergroth's original description copied]; Wygodzinsky 1949: 38.7 [catalog]; Sibley 1951: 92.43 [listed from Louisiana]; Elkins 1951: 409 [listed from Texas].

Hygromystes (Ceballum) armatus Fracker and Bruner 1924: 172 [♂, Ceballos, Camagüey Province, Cuba; disposition of type not stated]; Bruner 1926: 80.27; Blatchley 1926: 580, note 70 [as probable synonym of *D. interjungens*]; Bruner and Barber 1937: 188 [as new synonym of *D. interjungens*].

[*Hygromystes flaccidus* Uhler MS], in Heidemann collection, Cornell University.

This is another variable species, ranging in length from 14.6 to 19.0 mm., and in humeral width from 1.65 to 2.13 mm. The largest females rival *D. lauta* in length but are at once distinct by the

narrowly tapering abdomen which is not widest behind the middle and by the much shorter hemelytra.

No discal spines occur on the pronotum of *D. interjungens*, and commonly the lateral spines are reduced to tiny spinules; often they too are entirely absent, yet rarely (in Cuban specimens) they are well developed. The cephalic spines are small, as in *D. penalea*. Commonly the first two connexival segments bear spines; sometimes the third is acutely prominent but is never distinctly spined. Hemelytra of the males usually reach only to the apical third of the seventh tergite, but sometimes they attain or barely surpass the abdominal apex. In females too the hemelytra fail to reach the base of the eighth tergite; and since the eighth segment (Fig. 9) is more narrowly elongate than in other species, the females of *interjungens* have a distinctive habitus which is approached only by females of *D. bicarinata*.

Bergroth described *Doldina praetermissa* from two female specimens, flatly refusing to name either of them as type. One of his cotypes, from British Honduras, has not been located. The other, which was listed first under the description, was from Charlotte Harbor, Florida. Mrs. Slosson gave this specimen many years ago to Mr. H. G. Barber, according to information received from him, and it is now deposited in the U. S. National Museum. We hereby designate it the lectotype of *Doldina praetermissa* Bergroth.

The only differential character given by Bergroth to separate his two species was the presence of supra-humeral spines in *interjungens* and their absence in *praetermissa*, but Barber (1923) noted that this character did not hold good in topotypic specimens of *praetermissa* collected by Mrs. Slosson. We cannot find that two distinct species of *Doldina* occur in the United States, and agree with Blatchley that *praetermissa* should be placed as synonymous with *interjungens*.

We have considered the possibility that Bergroth, when describing *praetermissa*, had females of two species before him, the one from Belize perhaps being referable to the common Honduranian *D. penalea*, just described above. But *D. interjungens* also occurs in Honduras; and the females of these two species are so different in habitus that a hemipterist of Bergroth's wide experience would surely have recognized *penalea* as distinct from the species occurring in Florida.

Through the courtesy of Ing. F. Valdes Barry we have seen the two female specimens standing as *D. armata* (F. & B.) in the collection of the Estación Experimental Agronómica at Santiago de las Vegas. They were collected several years after the species was described, and were among the specimens reported by Bruner and Barber (1937) when they synonymized *armata* with *interjungens*. As noted by these authors, the supra-humeral spines are much better developed in these Cuban examples than in any we have seen from North America, but they alone are not sufficient to warrant recognition of a Cuban species distinct from *interjungens*.

Male. Median process of hypopygial margin (Fig. 8) much wider than in any other species, most commonly broadly triangular as seen from behind, rarely with sides less strongly convergent on basal than on apical half. Claspers very slender, long, distinctly surpassing median hypopygial process when seen from side.

Female. Eighth tergite (Fig. 9) little more than one-third wider at base (including connexivum) than its median length, apex produced somewhat beyond base of pygidium; apex of abdomen quite pilose, hairs partly concealing the oblique pygidium whose tip is only slightly caudad of apex of eighth tergite.

The specimens we have seen are from the following localities:

FLORIDA: Manatee, Cortez Beach, Paradise Key (Royal Palm Hammock), Cape Sable, Ocala National Forest in Marion County, Leesburg, and Cedar Key (Univ. Mich. Mus.); Fort Myers, Fort Lauderdale, Palm Beach, and Paradise Key (U.S.N.M.); Key Largo and Martin County (Fla. Plant Board); Enterprise and Biscayne (Cornell Univ., ex Heidemann); Dunedin and Atlantic Beach (Calif. Acad. Sci., ex Van Duzee); Lutz (Hillsborough County) (Carnegie Mus.).

GEORGIA: Tybee (Calif. Acad. Sci.); Tybee Island (Cornell Univ.).

LOUISIANA: Lake Charles (Univ. Mich. Mus.); Baton Rouge (Elkins coll.).

TEXAS: Galveston and other Gulf coast localities; Huntsville (Elkins coll.).

HONDURAS: Without definite locality, intercepted at New Orleans (U.S.N.M.).

CUBA: Santiago de las Vegas, Habana Prov., and Jaronú, Camagüey Prov. (Estac. Exp. Agr. Cuba).

ISLE OF PINES: Nueva Gerona, on lemon (U.S.N.M.).

Key to the Species of *Doldina* Stal

1. Distinct spines present on apical angles of all connexival segments (5 in male, 6 in female) 2
 Distinct spines present on not more than three proximal segments of connexivum 3
2. Head about one-sixth shorter than pronotum; first antennal segment subequal to or slightly shorter than head and pronotum combined; male pygidium produced behind as a narrow, short, obtusely pointed process *cubana* Barber and Bruner
 Head as long as or slightly longer than pronotum; first antennal segment as long as or longer than head, pronotum, and scutellum combined; postero-lateral submargins of pronotum very plainly depressed below margins, posterior angles lightly produced backward as small lobules; male pygidium seen from below (Fig. 1) obovate, without a short, narrow apical process *bicarinata* Stal
3. Hind lobe of pronotum either distinctly 4-spined, or with a supra-humeral spine (usually well developed) or spinule plus a small spine or tubercle⁴ each side on disk 4
 Hind lobe of pronotum either wholly unarmed, or with a small supra-humeral spine or tubercle only, the disk unarmed 5
4. Membrane, connexivum, and hind femora without fuscous spots; first three connexival segments spinose; post-antennal spines at least half as long as vertical height of an eye; discal spines of pronotum most commonly well developed, seldom much shorter than lateral ones and most rarely reduced to small tubercles; postero-lateral submargins of pronotum depressed below the sub-callose margin, posterior angles produced backward as small lobules (slightly larger than in *bicarinata*) *carinulata* Stal
 Closed cells of membrane with numerous fuscous spots and dashes, hind femora lightly spotted with fuscous, connexival segments above and below with a blackish spot in apical angles; a small piceous digitiform spinule on first connexival segment only; post-antennal spines very small; lateral spines of pronotum minute, discal spines (always?) reduced to small

⁴ Not infrequently one or both discal spines may be broken off close to the pronotum, so that the remaining basal portion appears like a small tubercle. If supra-humeral spines are broken, this usually occurs farther from their bases.

- tubercles not higher than their own diameter
 *limera* new species
5. Front femora, seen from above, with light but distinct bisinuuous lateral curvature; larger species, more robust, more than 18.5 mm. long, pronotum about one-tenth longer than wide, its posterior and postero-lateral margins lightly sinuate
 *lauta* (Stal)
- Front femora straight; smaller, more slender species, usually less than 18 mm. long, pronotum at least one-fourth longer than wide, its posterior and postero-lateral margins straight or virtually so 6
6. Meso- and metapleura concolorous, not striped with fuscous, front lobe of pronotum commonly embrowned toward sides above; first antennal segment, legs, and sides of head with rather dense, long, silvery or concolorous pilosity; pronotum wholly unarmed; hemelytra very nearly (♀) or quite (♂) attaining apex of abdomen *penalea* new species
- Meso- and metapleura with a broad dark-brown vitta, often extended back onto sides of abdomen and sometimes also (in darkest specimens) forward on sides of head below eyes; antennae, legs, and sides of head more shortly and less densely pilose; pronotum without discal spines, the supra-humeral pair sometimes absent, rarely well developed, most commonly present as minute, usually concolorous spinules; hemelytra most rarely (in some males only) surpassing apex of seventh tergite *interjungens* Bergroth

LITERATURE CITED

BARBER, H. G.

1914. Insects of Florida. II. Hemiptera. *Bull. Amer. Mus. Nat. Hist.* 33(31): 495-535.

1923. Report on Certain Families of Hemiptera-Heteroptera Collected by the Barbados-Antigua Expedition from the University of Iowa. *Univ. Iowa Stud. Nat. Hist.* 10(3): 17-29.

BARBER, H. G., and S. C. BRUNER

1946. Records and Descriptions of Miscellaneous Cuban Hemiptera. *Bull. Brooklyn Ent. Soc.* 41(2): 52-61, 5 figs.

BERGROTH, E.

1913. On some North American Hemiptera. *Ent. News* 24(6): 263-267.

BLATCHLEY, W. S.

1926. Heteroptera or True Bugs of Eastern North America. 1116 pages. Indianapolis: Nature Publ. Co.

BRIMLEY, C. S.

1938. The Insects of North Carolina. 560 pages. Raleigh.

BRUNER, S. C.

1926. Sipnosis [sic] de los Redúvidos de Cuba (Hemiptera-Heteroptera). *Mem. Soc. Cubana Hist. Nat.* "Felipe Poey" 7(1-2): 65-82.

BRUNER, S. C., and H. G. BARBER

1937. Additional Notes on Cuban Reduviidae (Hemiptera-Heteroptera). *Mem. Soc. Cubana Hist. Nat.* 11(3): 181-190.

ELKINS, JOE C.

1951. The Reduviidae of Texas. *Texas Jour. Sci.* 1951(3): 407-412.

FRACKER, S. B., and STEPHEN C. BRUNER

1924. Notes on some Neotropical Reduviidae. *Ann. Ent. Soc. Amer.* 17(2): 163-174.

READIO, P. A.

1927. Studies on the Biology of the Reduviidae of America North of Mexico. *Kansas Univ. Sci. Bull.* 17(1): 5-291, 21 pls.

SIBLEY, LONNIE M.

1951. A Study of Reduviids in Louisiana. *Proc. Louisiana Acad. Sci.* 14: 88-93.

STAL, C.

1859. Till kännedomen om Reduvini. *Ofv. Vet. Akad. Förh.* 16: 363-385.

1862.⁵ Bidrag till Rio Janeiro-traktens Hemipter-fauna. *K. Svensk. Vet. Akad. Handl.* 2(7): 1-84.

1866. Bidrag till Reduviidernas kännedom. *Ofv. Vet. Akad. Förh.* 23(9): 235-302.

1872. Enumeratio Hemipterorum, 2. *K. Svensk. Vet. Akad. Handl.* 10(4): 1-159.

de la TORRE-BUENO, J. R., and G. P. ENGELHARDT

1910. Some Heteroptera from Virginia and North Carolina. *Canadian Ent.* 42(4): 147-151.

VAN DUZEE, E. P.

1917. Catalogue of the Hemiptera of America North of Mexico, excepting the Aphididae, Coccidae and Aleurodidae. *Univ. California Publ., Techn. Bulls. Ent.*, Vol. 2. xiv + 902 pages.

WYGODZINSKY, PETR

1949. Elenco sistemático de los Reduviiformes americanos. *Inst. Medic. Reg., Univ. Nac. Tucumán, Monogr.* No. 1. 102 pages.

⁵ Stal himself and most later writers have given 1860 as the date of this publication. The copy before us, with the original paper cover bound in, bears the date 1862. Perhaps separates were issued in 1860, but under the *Règles* this would not constitute publication.

A NEST OF THE ATLANTIC LEATHERBACK TURTLE,
DERMOCHELYS CORIACEA CORIACEA (LINNAEUS),
ON THE ATLANTIC COAST OF FLORIDA, WITH A
SUMMARY OF AMERICAN NESTING RECORDS ¹

DAVID K. CALDWELL, ARCHIE CARR, and THOMAS R. HELLIER, JR.
University of Florida

Carr (1952: 451) pointed out that there has been only one reliable record of the nesting of the Atlantic Leatherback turtle, *Dermochelys coriacea coriacea* (Linnaeus), on the North American mainland beaches during the last 100 years. The case referred to was an emergence in June, 1947, on Flagler Beach, Flagler County, Florida. The evidence given below is thus apparently the second instance, reported by a zoologist, of a leatherback or trunkback, nesting on a North American shore in recent decades; and though the turtle itself was not seen by us, the data seem clear enough to be considered valid. An account of a third such emergence which recently occurred in south Florida is now being prepared for publication by Mr. Wilfred T. Neill of Ross Allen's Reptile Institute.

On the night of July 22, 1955, in company with several other persons, two of us (Caldwell and Hellier) were tagging female Loggerhead turtles, *Caretta caretta caretta* (Linnaeus), as they came out to lay on Hutchinsons Island, Martin County, Florida, opposite the town of Jensen Beach. We were met by Mr. Newt Chase, local officer of the Florida State Board of Conservation, who informed us that a trunkback had nested near the south end of the island about a week or ten days before. The officer did not see the turtle, but it was reported to him by a person who had witnessed the event. He went to the spot with the witness on the next night and found that the tracks, which he measured to be nine feet between the outermost marks of the flipper tips, were still plainly visible. The witness told him that the eggs had been about the size of baseballs. The white sand beach is fairly steep at this point and the nest site was located about 75 feet above normal high water, just at the edge of a line of rather high dunes.

¹Field work supported in part by National Science Foundation Grant G-1684, University of Florida (Principal investigator, Archie Carr), a project on which Caldwell was Research Assistant during the summer of 1955.

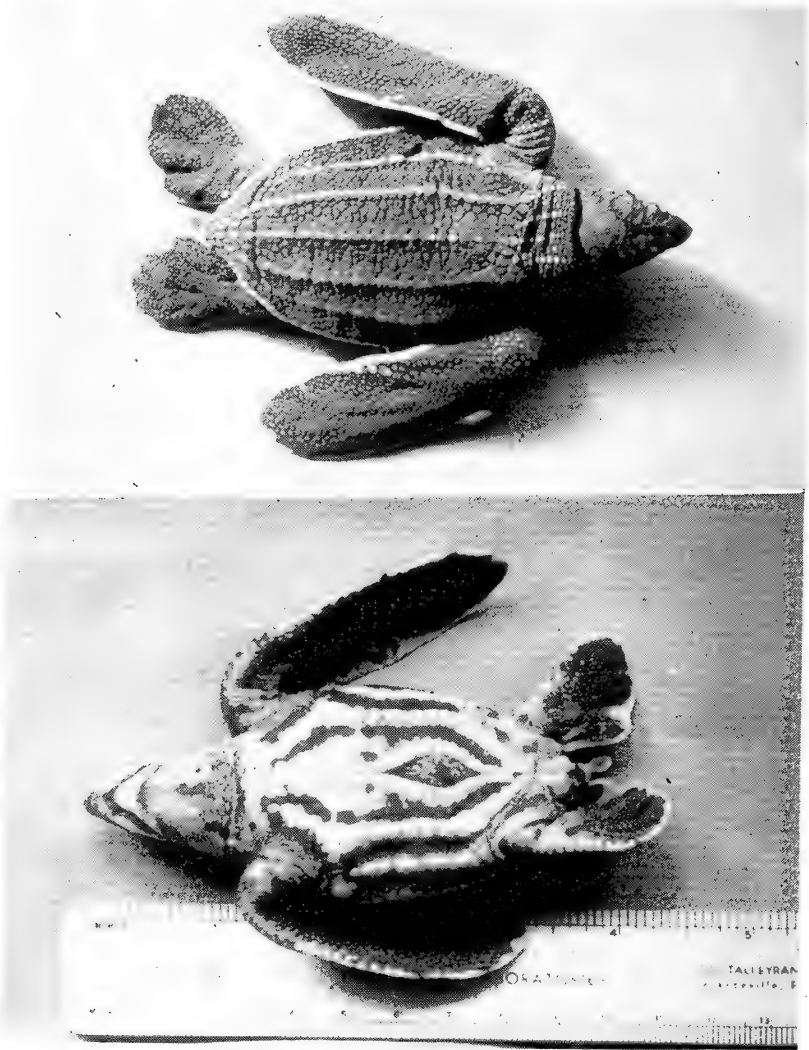

Figure 1. (*upper* and *lower*). Dorsal and ventral views of a hatchling Atlantic Leatherback turtle from Tortuguero, Costa Rica. Note umbilical scar on ventral side. Specimen now UF Accn. No. 16. (Photographs by Leonard Giovannoli.)

We returned to the spot on the 22nd in company with Chase, and found that the tracks were still visible, though partly destroyed by the wind. Even at this late date they were about seven feet across, much too wide for a loggerhead or any other species of sea turtle. The disturbed nest area measured about 12 by 15 feet.



Figure 2. Carefully excavated nest of an Atlantic Trunkback turtle at edge of *Ipornea* zone on beach near Toco, northern coast of Trinidad. The diameter of the opening is thought to correspond closely with the mouth of the original excavation. The stick, which was 49 inches long, rests on what seemed clearly to be the bottom of the nest as dug by the turtle. (From a Kodachrome by Archie Carr.)

The next morning we returned to the site armed with shovels, but were unable to recover any eggs, though we dug holes and trenches to a minimum of $3\frac{1}{2}$ feet over the visible nest area. While it is well known that the large size of this species permits it to bury its eggs quite deep (Carr, 1956: 77), we felt that we should have discovered the top of the nest, though as it is further pointed out (Carr, 1952: 391; 1956: 99), it is often astonishingly hard to find the eggs of even smaller species of sea turtles after they have been covered, even if the entire laying process has been watched. Unfortunately, sea turtle eggs are much in demand by pastry



Figure 3. (*upper and lower*). Eggs from the nest in Figure 2. The extreme range in egg size is characteristic of trunkbacks, both Atlantic and Pacific. The coin shown is an English half crown. The big egg in the graded series was $2 \frac{1}{16}$ inches in diameter and most of the eggs in the nest were, with the wooden calipers used, not measurably different. There were 8 undersized eggs in the clutch of 50. (From Kodachromes by Archie Carr.)

cooks, and it is of course quite possible that the witness took the eggs, refilled the hole, and failed to report this to the conservation agent.

Mr. Chase stated that though he had never seen one himself, two or three trunkbacks are reported nesting in this area each summer.

American nesting records for the Atlantic Leatherback are as follows:

FLORIDA: Flagler Beach, Flagler County, June 6, 1947 (Carr, 1952: 451); Hutchinsons Island, Martin County, (see above). JAMAICA: West end (Negril Bay), March 30 and April 10, 1846 (Gosse, 1851: 306). COSTA RICA: Tortuguero, May, 1953 (Carr, 1954: 138); Tortuguero, June, 1954, several old nests; Tortuguero, July 12, 1955, a single hatchling taken by Leonard Giovannoli (see Figure 1)—with measurements as follows: Carapace length 64 mm (2.56 in.); carapace width, 42 mm (1.68 in.); weight, 44.9 gms (0.099 lbs.). TRINIDAD: Near Toco (northern coast), three nests, August 29, 1953 (Carr, 1954: 138; 1956: 98; see Figures 2 and 3); in the Royal Victoria Institute, Port of Spain, there is a photograph of a trunkback with the notation that it had been taken on the beach at Manzanillo (eastern coast) near the mouth of the Oropuche River, where it had laid 150 eggs the night of May 29, 1937. TOBAGO: August, 1953, old nest (Carr, 1954: 138). Schmidt (1916: 9) named the islands of St. Croix and Tortola, in the Danish West Indies, as sites of nesting emergence, and Audubon (1926: 196) said that trunkbacks nested on the Florida Keys. Honduras, Nicaragua, the Bahamas, and Brazil have also been noted on the basis of old or word-of-mouth accounts as breeding localities (Carr, 1952: 451).

LITERATURE CITED

AUDUBON, JOHN JAMES

1926. *Delineations of American Scenery and Character*. G. A. Baker and Co., New York, pp. 194-202.

CARR, ARCHIE

1952. *Handbook of Turtles*. Comstock Publishing Associates, a division of Cornell University Press, Ithaca, New York. pp. xv + 542.
1954. The zoogeography and migrations of sea turtles. *Year Book of the American Philosophical Society*, 1954, pp. 138-140.

1956. *The Windward Road*. Alfred A. Knopf, New York. pp. xvi + 258 + viii.

GOSSE, P. H.

1851. *A Naturalist's Sojourn in Jamaica*. Longman, London. pp. xxiv + 508.

SCHMIDT, J.

1916. Marking experiments with turtles in the Danish West Indies. *Meddelelser Kommissionen Havundersogelser, Ser: Fiskeri*, 5: 1-26.

Quart. Journ. Fla. Acad. Sci. 18(4), 1955.

(Continued from Page 238)

than was needed for the particular project and some could be diverted to other activities.

The Academy Conference and the Council of the A.A.A.S. agreed on a new basis for the distribution of the small research fund which the Academies receive each year from the A.A.A.S. Grants are to be made for the support of outstanding research projects with consideration being given to applicants in the following order: First, High School students (for projects of the type which are entered in the National Science Talent Search); second, undergraduate students and third, graduate students and faculty members. In each category special consideration is to be given to applicants from the smaller institutions with limited budgets, and none of the money is to be used for prizes or rewards.

The afternoon and evening sessions of the Academy Conference were devoted to a series of discussions on two topics. The first of these was The Role of Academies of Science in the A.A.A.S. Science Teaching Improvement Program. Among the suggestions made along this line were: continued and increased activity by the Senior Academies in establishing and supporting Junior and Collegiate Academies, Science Fairs and Science Talent Searches; and the appointment of Special Academy Committee(s) to make recommendations for improvement in the training of science teachers and especially to help with the establishment of inservice training programs, and to examine existing science curricula in the high schools and try to improve them, especially from the laboratory standpoint.

The second topic of discussion dealt with Science Fairs as an Academy activity. The importance of stimulating an interest in science among students at the Junior High level was discussed and the value of Science Fairs in helping to promote such an interest was pointed out. The Oak Ridge Institute of Nuclear Studies has some very interesting publications in which this matter is discussed at some length.

The Conference concluded with the annual dinner on Wednesday evening.

E. RUFFIN JONES
Academy Conference Representative

THE CHARACTERISTICS AND DISTRIBUTION OF THE
SPOTTED CUSK EEL *OTOPHIDIUM OMOSTIGMUM*

(Jordan and Gilbert)

JOHN C. BRIGGS and DAVID K. CALDWELL
University of Florida

The authors recently had the privilege of observing five living specimens of a rare cusk eel at Marineland, Florida.¹ Two additional individuals were later examined, one from Cortez Beach, Florida,² on the lower Gulf coast, and the other from Cedar Key, Florida, about 120 miles further north on the west coast. Since only two specimens had previously been reported (each described as a separate species), both the morphology and the behavior of these individuals were investigated with considerable interest.

Otophidium omostigmum (Jordan and Gilbert)

Genypterus omostigma Jordan and Gilbert, 1882: 301-302 (Pensacola, Florida).

Otophidium omostigma Jordan, 1887: 914. Goode and Bean, 1895: 345, fig. 305 (Pensacola) Jordan, Evermann, and Clark, 1930: 485 (Pensacola snapper banks).

Otophidium omostigmum Jordan and Evermann, 1898: 2490 (Snapper banks off Pensacola).

Otophidium grayi Fowler, 1948: 1-4, fig. 1 (Marineland, Florida).

DESCRIPTION

The initial values given in the text are the arithmetic means of all specimens measured; the values included in parentheses are the extremes. A robust species, probably attaining a larger size than the other members of this genus. Body depth (taken at dorsal origin) 6.0 (5.2 - 6.3) and head length 4.1 (3.9 - 4.6) in standard length. Head width 1.8 (1.6 - 2.1), snout 3.5 (3.2 - 3.9), eye diameter measured horizontally 4.4 (4.0 - 4.8), and bony interorbital

¹ We are indebted to the directors of the Marine Studios, Marineland, Florida, and to their Scientific Curator, Mr. F. G. Wood, for furnishing both facilities and specimens.

² Obtained as a loan from the University of Miami through the courtesy of Mr. Luis R. Rivas.

space 6.0 (5.1 - 7.1) all in head length. Eye diameter measures 1.3 (1.0 - 1.5) in snout. Mouth slightly inferior; maxillary slopes a little downward from front of snout and reaches to a point under the posterior edge of the pupil. A pair of inconspicuous nostrils on each side, the anterior nostril close to the tip of the snout and the posterior about halfway between the tip and the anterior edge of the eye. A broad band of villiform teeth in both jaws. Teeth on vomer larger, blunt, rounded, extended along the palatines in two or three rows. The gill rakers are large and each is provided with many minute, sharp spines; 4 (4 - 5) on the lower limb of the first arch, the lower three somewhat flattened and elongated; 7 (6 - 8) on second arch, knob-like.

The head is naked, the skin on the top being compressed into a series of very fine, parallel wrinkles. Scales small, thin, cycloid and imbedded in groups at irregular angles; 20 (17 - 24) in the predorsal series and approximately 160 - 185 along the lateral line to the caudal base. The lateral line can be seen as a small tube which disappears somewhat in front of the caudal base; it opens to the exterior through two series of pores, one above the line and another below.

The median rays were extremely difficult to count, since they are delicate and the fins are quite thick and fleshy. About 117 - 126 dorsal rays were found, about 85 - 95 anal, and 8 - 10 caudal. Pectoral rays 20 (19 - 22) and ventral rays 2; the outer ventral ray about twice as long as the inner; this entire ventral apparatus borne on a movable pedicle which projects from the chin (Figure 1).

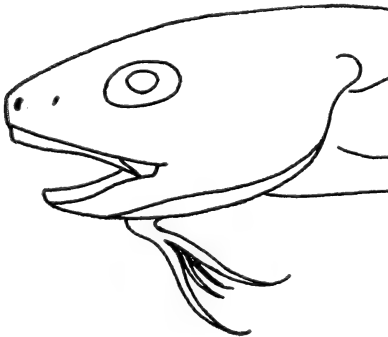

Figure 1. Profile of head showing the ventral pedicle bearing the filaments.

The genus *Otophidium* is still in a most confused state. However, evidently four other western Atlantic species should be recognized, *O. marginatum* (DeKay), *O. schmidtii* Woods and Kanazawa, *O. welshi* Nichols

and Breder, and *O. holbrooki* (Putnam). *O. omostigmum* is immediately distinguishable by its unique color pattern which, fortunately, does not easily fade in alcohol. In fact, the only one of the

other four that possesses distinct markings on the body is *O. welshi*, but these are in the form of four longitudinal lines and could not be easily confused with the large, irregular blotches of *O. omostigmum*.

LIVE COLORATION

Though the color in alcohol has been adequately described by Goode and Bean (1895: 345), and Fowler (1948: 2), its coloration in life has not been previously reported.

Base color a light brown with a very definite pinkish cast, with dark, chocolate-brown blotches; somewhat darker above than below, though the above general colors persist, varying only in degree of intensity. The dorsal, anal, caudal, and pectoral fins edged in dark brown, with the exception of a chalk white area (persisting after preservation) on the edge of the dorsal, extending approximately $1/10$ the length of the fin, beginning at a point about $1/4$ the fin's length from its origin.

MATERIAL EXAMINED

University of Florida number 4572; five specimens from St. Augustine, Florida (three of these will be deposited elsewhere, at the U. S. National Museum, Stanford University, and the Chicago Natural History Museum). University of Florida number 4458; one from Cedar Key, Florida. Academy of Natural Sciences of Philadelphia number 71737; one (holotype of *Otophidium grayi*) from Marineland, Florida. University of Miami (not catalogued); one from Cortez Beach, Florida.

REMARKS

As is shown by Table 2, plus a comparison with available data on the holotype, certain ontogenetic changes in proportion are noticeable: the body depth becomes relatively greater, the inter-orbital space greater, and the snout longer. However, the changes which occur in the air bladder as the result of both growth and sexual maturity are the most interesting. Jordan and Gilbert (1882: 302) found a large posterior foramen in the air bladder of the holotype (a small specimen of only about 90 mm.). In all of our specimens (160 mm. to 293 mm.) the air bladder is entire and, also, a remarkable type of sex dimorphism is demonstrated. In the two

females this structure is more or less heart-shaped from a ventral view (Figure 2), but in the five males (the largest specimens) a prominent posterior projection (Figure 3) is developed. This protrusion is hollow and covered by a membrane at the distal end. Furthermore, this membrane is very elastic and presumably can extend a considerable distance into the coelomic cavity when pressure is exerted upon the comparatively rigid air bladder. Harry (1951: 32) first called attention to the widespread occurrence of this type of sexual dimorphism in the Ophidiidae. Its discovery in this species serves to further indicate it may be a fundamental characteristic of the entire family.

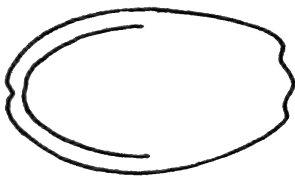

Figure 2. Outline of air bladder from a ventral view; anterior end to the right. Female.

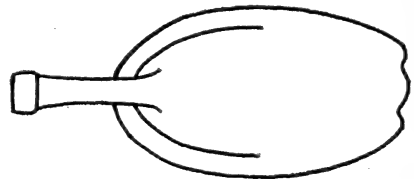

Figure 3. Outline of air bladder in same position as Figure 2. Male.

We consider *Otophidium grayi* Fowler to be a synonym of *O. omostigmum* (Jordan and Gilbert), because the original description of the latter plus the figure drawn by Todd and published by Goode and Bean (1882, figure 305) reveal no well-defined differences that could not be attributed to the juvenile state of the holotype.

TABLE 1
Measurements in Millimeters of Seven Specimens

	Cedar Key Specimen	From Marineland, Florida					Cortez Beach Specimen
Standard length	160	215	255	255	258	260	293
Body depth	25.2	35.0	42.5	44.0	46.1	43.2	56.1
Head length	34.8	53.5	62.0	61.6	66.5	63.8	65.6
Head width	16.4	30.0	38.4	38.2	38.4	39.3	39.6
Snout	9.0	14.6	18.1	18.3	19.8	19.7	19.8
Eye diameter	8.7	12.6	13.0	13.2	15.7	13.5	13.6
Interorbital	5.3	7.5	12.1	10.8	10.7	11.2	12.1
Maxillary	13.8	21.0	24.2	25.0	27.5	25.5	28.8
Longest ventral ray	16.2	24.2	26.4	28.9	28.7	27.9	25.4

RANGE

From Pensacola, Florida, in the Gulf of Mexico, around the peninsula to St. Augustine, Florida, on the Atlantic Coast.

TABLE 2
Measurements as per cent of standard length

	Cedar Key Specimen	From Marineland, Florida					Cortez Beach Specimen
Body depth	15.8	16.3	16.7	17.3	17.9	16.6	19.1
Head length	21.8	24.9	24.3	24.2	25.8	24.5	22.4
Head width	10.2	14.0	15.1	15.0	14.9	15.1	13.5
Snout	5.6	6.7	7.1	7.2	7.7	7.6	6.8
Eye diameter	5.4	5.9	5.1	5.2	6.1	5.2	4.6
Interorbital	3.3	3.5	4.7	4.2	4.1	4.3	4.1
Maxillary	8.6	9.8	9.5	9.8	10.7	9.8	9.8
Longest ventral ray	10.1	11.3	10.4	11.3	11.1	10.7	8.7

HABITAT

At the Marine Studios this is not now considered a rare form, since individuals seem to be generally available during the cooler parts of the year. The east coast specimens were all taken on November 23, 1954, by an otter trawl over a mud bottom at 35 - 40 feet, about one mile off the beach at St. Augustine. The Cedar Key specimen was taken on March 10, 1953, in a shrimp net at 18 feet, about 8.5 miles west of the town of Cedar Key. The Cortez Beach individual was found dead, presumably killed by the red tide outbreak of December, 1953.

OBSERVATIONS ON LIVE INDIVIDUALS

Observation of five live specimens at Marineland showed that the habits of this species have much in common with those of a Pacific cusk-eel (*O. taylori*) as reported by Herald (1953: 381). Though *O. omostigium* never displayed the "tail standing" habit described for *O. taylori*, it did exhibit other habits noted for the latter species.

Individuals quickly buried themselves tail first on their sides, often until only the very tip of the snout protruded, though sometimes the burial was only partially completed. They burrowed in the open sand on the aquarium bottom, under flat rocks, and, on one occasion, beneath a small flounder which was itself buried

in the sand. Sometimes they would lie on their sides completely exposed, either prone or partially curled (Figure 5). In all cases of burial, partial burial, or exposed "side lying", the animals appeared dead, and considerable stimulation was usually needed in order to make them resume a swimming position. This sluggishness may account for their apparent rarity, since a trawl or other net might easily pass over one and fail to frighten it out of hiding and into the net.

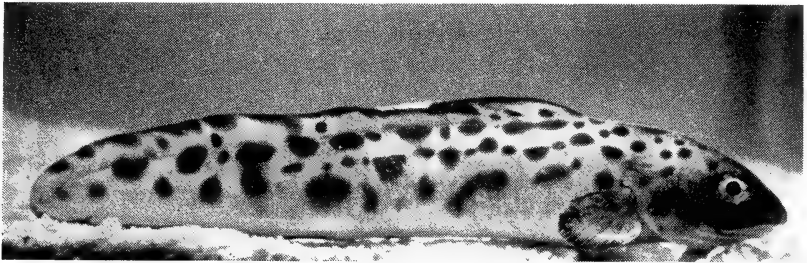

Figure 4. Live specimen in swimming position.

O. omostigmum shows a negative phototrophism, moving away from a strong artificial light and also away from a patch of sunlight in the aquarium. The ventral fins are highly movable and apparently have an important tactile and perhaps an olfactory function; they are kept in continuous motion as the fish swims along just off the bottom. Food was not accepted until after it came in contact with these ventral filaments.



Figure 5. Live specimen in resting position.

LITERATURE CITED

FOWLER, HENRY W.

1948. Description of a new cusk (*Otophidium grayi*) from the east coast of Florida. *Notulae Naturae, Acad. Nat. Sci. Philadelphia*, No. 204: 1-4, 1 fig.

GOODE, GEORGE B., and TARLETON H. BEAN

1895. Oceanic ichthyology, a treatise on the deep-sea and pelagic fishes of the world. *Smithsonian Contrib. to Knowledge* No. 981; xxxv + 1-553, 123 pls., 417 figs.

HARRY, ROBERT R.

1951. A new cusk-eel of the genus *Ophidion* from California, with notes on the genus. *Stanford Ichthy. Bull.*, 4(1): 30-35, 5 figs.

HERALD, EARL S.

1953. Spotted cusk-eel, the strange fish that stands on its tail. *California Fish and Game*, 39(3): 381-384, 3 figs.

JORDAN, DAVID S.

1887. A catalogue of the fishes known to inhabit the waters of North America north of the Tropic of Cancer, with notes on the species discovered in 1883 and 1884. *Rept. U. S. Comm. Fish*, 1885, 13: 789-973.

JORDAN, DAVID S., and BARTON W. EVERMANN

1898. Fishes of North and Middle America. *Bull. U. S. Nat. Mus.*, 47(3): xxiv, 2183-3136.

JORDAN, DAVID S., and CHARLES H. GILBERT

1882. Notes on fishes observed about Pensacola, Florida, and Galveston, Texas, with description of new species. *Proc. U. S. Nat. Mus.*, 5: 241-307.

JORDAN, DAVID S., BARTON W. EVERMANN, and HOWARD W. CLARK

1930. A check list of the fishes and fishlike vertebrates of North and Middle America north of the northern boundary of Venezuela and Colombia. *Rept. U. S. Comm. Fish.*, 1928 (2): 1-670.

NATURAL HISTORY NOTES ON THE ATLANTIC
LOGGERHEAD TURTLE, *CARETTA CARETTA CARETTA*

DAVID K. CALDWELL, ARCHIE CARR, and THOMAS R. HELLIER, JR.
University of Florida

During a general study of the Atlantic forms of American sea turtles,¹ centered chiefly upon the Atlantic Green turtle, *Chelonia mydas mydas* (Linnaeus), and the Atlantic Ridley, *Lepidochelys kempi* (Garman), a number of notes on the Atlantic Loggerhead turtle, *Caretta caretta caretta* (Linnaeus), have accumulated. While sketchy and inconclusive, they nevertheless add something to our remarkably incomplete knowledge of an animal that is familiar to most of the inhabitants of the Gulf coast and the southern Atlantic seaboard.

Thirty-seven loggerheads were marked during the summers of 1953, 1954, and 1955. All were females, taken when they came out to lay. Two kinds of inscribed tags were used. The earlier was a 1-inch circular monel metal disk, the later version an approximately 2- by 1½-inch oval. In each case the tag bore a number and was inscribed, in Spanish and English, with instructions for its return. Most of the work was done on the east coast of Florida (Figure 1) from Fort Pierce (Indian River Inlet) south to Jupiter Inlet, a distance of about 40 miles. Some turtles were tagged at Cocoa Beach near Cape Canaveral and at Daytona Beach. A single individual was tagged on St. Vincents Island, near Apalachicola, Franklin County, Florida (northern coast of the Gulf of Mexico, not shown on Figure 1) in 1955.

Of the marked turtles only one has been retaken. This, unfortunately, was an individual tagged by a student from the University of Florida who volunteered to help with the tagging program and then failed to turn over his notes to us when he was drafted into military service. We know only that the tag was put on late in June, 1955, at Fort Pierce. It was recovered when the turtle was retaken July 15, 1955, by a shrimp trawler off Daytona Beach. The shoreline distance traveled by the turtle was about 130 miles (Figure 1).

¹Field work supported in part by National Science Foundation Grant G-1684, University of Florida (Principal investigator, Archie Carr), a project on which Caldwell was Research Assistant during the summer of 1955.

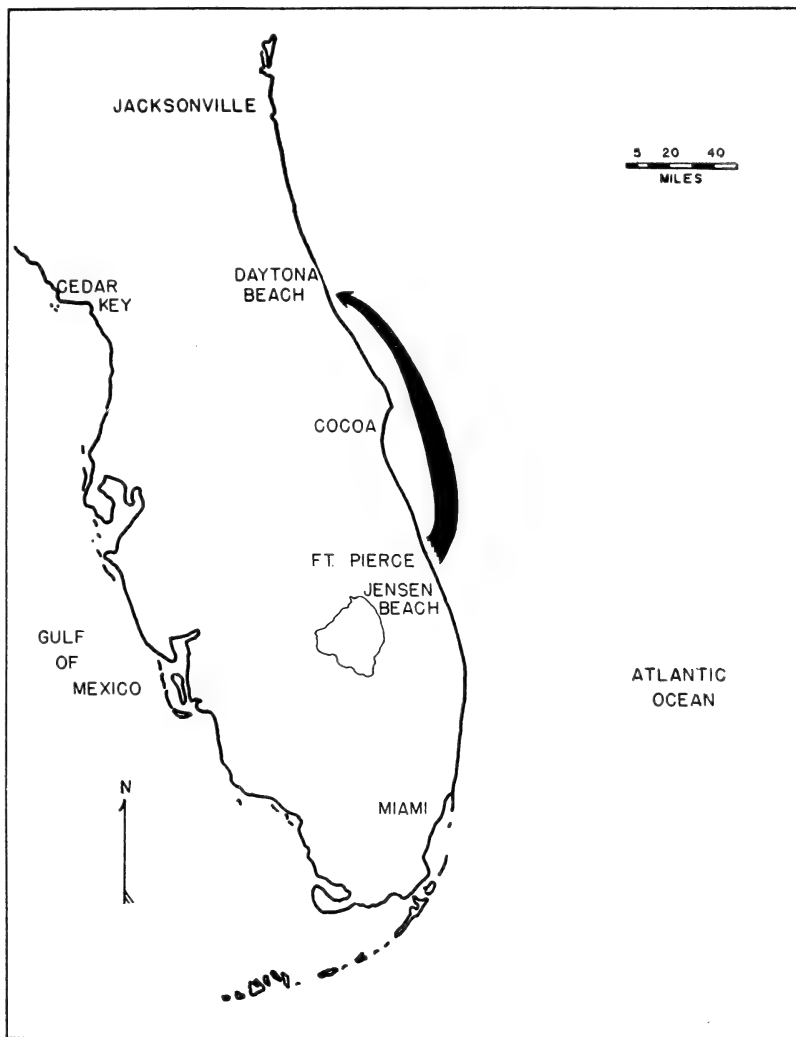

Figure 1. Map of peninsular Florida showing the areas where nesting female loggerheads were tagged during the summers of 1953, 1954, and 1955. The approximate path taken by a tagged individual before recovery is also shown.

NESTING BEHAVIOR

An interesting and unexplained aspect of the group behavior of sea turtles on a nesting beach is the tendency for emergences to clump, in time or about particular sections of beaches. Such a tendency has been noted at the green turtle rookery in Costa Rica, and notes made there during the summer of 1955 will be discussed elsewhere (Carr and Giovannoli, Ms.). Observations possibly bear upon this tendency in the loggerhead were made by Caldwell and Hellier on July 22-23, 1955, at Hutchinsons Island, opposite Jensen Beach, Martin County, Florida:

Nesting loggerheads were extremely common on this beach on the night of the 22nd. Seven and a half miles of beach were patrolled with a jeep, and this distance was covered twice. The evening was clear with little wind, the moon dark, weather warm, and the tide had just turned from flood to ebb, though the water was still fairly high during the 3½ hours spent on the beach. Nine turtles were tagged, another seen, and the fresh tracks of at least 25 others were observed. From our past experience on the beach and from conversations with Mr. Newt Chase, the local officer of the Florida State Board of Conservation, who had been on the beach every night during the season, this seemed, and still seems an exceptionally heavy emergence.

The next night we spent about the same time on the same stretch of beach at the same stage of the tide (thus, somewhat later in the evening) and saw only one fresh crawl and no turtles other than the one to be commented on below. Though Mr. Chase did not accompany us, we saw him during the evening and found that he had not seen any turtles or tracks except that one seen by us, and it might be added that he had covered an even longer stretch of beach than we had. Weather conditions were identical with those of the previous night with the one exception that there had been a high wind during the latter part of the previous night (after we left the beach) which had continued throughout the day, and partly into the second night. Perhaps as a result of this, there was a strong undertow and a heavy surf during the day and on the night of the 23rd. There had been practically no surf on the first night and conversation with the lifeguard on a part of the beach maintained by the county as a park proved that there had also been no undertow during the first day (the 22nd). The under-

tow had cut away a portion of the beach so that there was a definite step or low bluff (up to 12 inches) about midway between high and low water lines. This step was not present the night of the 22nd, nor did we remember its presence on any previous visit to the beach when turtles had been relatively plentiful. Just as we were about to give up on this second night we glimpsed a turtle emerging from the surf. We immediately turned off all lights and waited for her to come out. She continued to move up the beach until she came to the step, which was now about 30 feet from the water's edge. On encountering the rise she unhesitatingly turned and went back to the water. After she had gone, we examined her path and found that she had made no serious effort to get over the step obstruction which was about 8 inches high at this point. A further walk of $\frac{1}{2}$ mile revealed no more tracks or turtles.

Though the above data are scanty, it seems probable that the undertow (or related factors) and the step, when the water lowered enough for it to become a barrier, combined to discourage nesting that second night. The possible deterrent effect of steep-cut banks, and their relation to the Caribbean cocopalms fringe, is discussed by Carr (1956: 114-115, 122).

CUBAN NESTING RECORDS

There is apparently a dearth of reliable nesting records for the Atlantic loggerhead for localities outside the southern United States.

On November 16, 1954, two of us (Caldwell and Carr), while visiting the Marine Laboratory of the Banco de Fomento Agricola e Industrial de Cuba at Playa Baracoa, 15 miles west of Havana on the north shore of Cuba, were presented with two live baby loggerheads which had been taken a few weeks before, after hatching on the beach near the laboratory. These were preserved and are now in the University of Florida herpetology collection (UF 6817).

Other Cuban nesting records were established in the summer of 1955 when one of us (Carr) found shells of eight individuals along two miles of Varadero beach (Atlantic coast, province of Matanzas). Tracks and disturbed nests indicated that the shells were the remains of females that had been killed and butchered where found nesting.

Farther east on the Atlantic side of the island at Gibara, there is a commercial hawksbill, *Eretmochelys imbricata imbricata* (Linnaeus), fishery, and individuals connected with this stated that while hawksbills nest in abundance there in May, June, and July, loggerheads emerge only rarely.

As far as can be determined, the Playa Baracoa record is the southernmost definite nesting locality for the Atlantic loggerhead in America. Fishermen and turtle hunters questioned by Carr at points distributed throughout the Caribbean know the loggerhead as a member of the fauna, but in every case they name either the hawksbill or the green turtle, or both, as the only species regularly nesting in their area. In Trinidad and Tobago all fishermen questioned said flatly that loggerheads do not nest there. Elsewhere, nesting was said to occur sparingly—one or two emergences in a season. The nearest approach to a definite record is the statement by one of the men hired for the green turtle operation at Tortuguero, Costa Rica, that a loggerhead had come up on his section of beach during late July, 1955. Since he had been employed to turn only green turtles, he failed to turn the loggerhead.

Whatever the extremes of nesting range of the loggerhead may be, it seems evident that it is essentially a temperate zone breeder. The possible evolutionary implications of this divergence from other sea turtle species at the critical nesting time, when on good beaches nesting space can become the basis for strong competition, are of interest and probably of significance.

INCUBATION PERIODS

Although hatched under somewhat unnatural conditions, we have accurate incubation periods for two batches of loggerhead eggs to add to the scant data in the literature. In both cases, the eggs were taken as they were laid, moved to a spot where they could be watched conveniently, and reburied in the same type of sand in which they had been originally laid.

One batch was laid July 9, 1955, at Fort Walton Beach, on Santa Rosa Island, Okaloosa County, Florida and then reburied, two days later, back of the open beach near the second series of dunes. Most of these hatched on September 7, after an incubation period of 57 days.

The second batch was taken on July 22, 1955, at Hutchinsons Island, was transported in sand back to Gainesville, along with a supply of beach sand, and was reburied in a sunny yard there on July 25. These hatched September 30—an incubation period of 68 days. Only about one-third of these eggs hatched, possibly due to jolting on the trip back or to unnatural drainage or illumination factors in the new incubation site.

GROWTH OF HATCHLINGS

Two hatchling loggerheads were kept under artificial and somewhat confining conditions for a short period, during which they fed regularly. Measurements of the growth of these are presented in Table 1. Another group of young turtles (Table 2) was measured and weighed at the Gulfarium, The Living Sea, at Fort Walton Beach. Although no exact record had been kept of the ages of the turtles, and individuals from several hatchings were in the same tank, the 48 mm individual was measured about 2 weeks after hatching; those 53 to 71 mm were approximately 11 weeks old; and the one 81 mm was about 13 weeks. Since none of the turtles were marked, on being placed in the community tank, we cannot be certain that an occasional individual was not added to the group from a still different hatching; but the resident aquarists, J. B. Siebenaler and Winfield Brady, believe the above approximate ages to be essentially correct.

There is apparently a considerable variation in growth rates of individual young loggerheads (also noted by Hildebrand and Hatsel, 1927, and Parker, 1926, 1929), since most, if not all, of the 53 to 71 mm group above were from the one hatching of September 7 (see section on incubation periods). As may be seen in Tables 1 and 2, growth is quite slow for the first ten days or so and little weight is gained. This is undoubtedly due to the absorption of the yolk and accompanying fasting of the hatchling. After the hatchlings begin to eat regularly, a marked rise in rate of increase in length and weight occurs.

While it is probable that our captive hatchlings received an unnaturally steady and abundant food supply, other factors possibly tending to make theirs an unnatural growth, such as the confinement factor, the unvarying temperature, lack of "choice" in feeding, etc., are difficult to evaluate. So long as young sea turtles

continue to disappear from view after hatching, however, it is hard to see how early growth can be studied under more natural conditions.

TABLE 1

Growth of two juvenile loggerhead turtles hatched at Fort Walton Beach, Florida on September 7, 1955, and kept in captivity.

Age (days)	Carapace Length (mm)	Carapace Width (mm)	Weight (gms)
Specimen A			
7	46	38	17.8
8	46	38	18.3
9	46+	38+	19.0
10	46.5	39	19.9
11	47	40.5	20.1
12	47.5	41	19.7
13	47.5	—	20.2
14	48.5	—	21.3
16	49.5	—	22.7
27	49.5	—	23.1
20	50.5	—	24.5
Specimen B			
7	46	37	18.8
8	46	37	19.7
9	46+	37.5	19.7
10	46.5	38+	20.5
11	46.5+	38+	21.1
12	47	42	21.1
13	48	—	21.8
14	48.5	—	22.6
16	49+	—	23.6
17	49.5	—	23.3
20	50.5	—	25.5

RELATIONSHIP OF CARAPACE LENGTH TO CARAPACE WIDTH

Though we have only a small sample, some idea of the variation in the length-width relationship of the carapace of adult female loggerheads can be gained from Figure 2. Unfortunately, no comparable measurements are available for adult males. Carr (1952: 386) noted that adult males appear narrower than the females, or at least the carapace appears to be more elongate and tapering behind than in females. Unsexed hatchlings or slightly larger loggerheads exhibit only a slight variation in this relationship (Table

2) and the variation shown in the larger sized turtles must be a dual function of age within a sex and of difference between the sexes themselves.

TABLE 2
Measurements of loggerhead hatchlings and very young

Carapace Length (mm)	Carapace Width (mm)		Weight (gms)		Number of Specimens
	Mean	Range	Mean	Range	
Hatchlings (Eggs from Hutchinsons Island, Florida)					
44	35	34-35	18.4	17.4-19.4	3
45	35	34-36	17.4	17.1-17.7	2
46	35	—	19.6	—	1
47	36	35-37	18.9	18.8-18.9	2
Very young (Eggs from Santa Rosa Island, Florida) kept in captivity					
48	40	—	20.1	—	1
53	44	43-45	25.7	23.9-27.9	3
54	45	44-46	27.4	24.2-29.0	5
55	47	—	32.9	—	1
56	47	46-48	29.7	28.0-31.3	3
57	49	48-50	32.2	31.2-34.2	3
58	50	49-50	33.2	31.2-35.1	2
59	50	49-51	36.0	34.0-38.5	4
60	51	49-52	38.4	36.2-40.8	4
61	52	51-54	39.3	38.2-40.7	3
62	53	52-53	41.3	40.4-42.2	2
63	54	53-56	42.9	40.1-44.6	7
64	54	—	45.7	—	1
65	56	—	44.6	—	1
66	55	—	52.0	—	1
67	58	57-58	48.7	48.3-49.1	2
68	60	—	54.6	—	1
69	61	—	55.4	—	1
70	60	59-60	60.3	59.9-60.6	2
71	57	—	63.9	—	1
81	68	—	95.8	—	1

Carr and Caldwell (1956) showed that variation in the length-width ratio in Atlantic Green turtles and Atlantic Ridleys, while interesting in itself, is also an important factor in determining the relationship of length to weight in turtles of commercial size. This can be important in making decisions or recommendations in fishery work since two individuals of the same sex and length, but of different widths, may have greatly varying weights.

LENGTH-WEIGHT RELATIONSHIP OF HATCHLINGS AND VERY YOUNG

Though we have no weights for adults, we do have accurate data on the weights and carapace lengths of hatchlings and slightly older juveniles, the latter having been maintained in captivity since hatching. These data are presented in Tables 1 and 2.

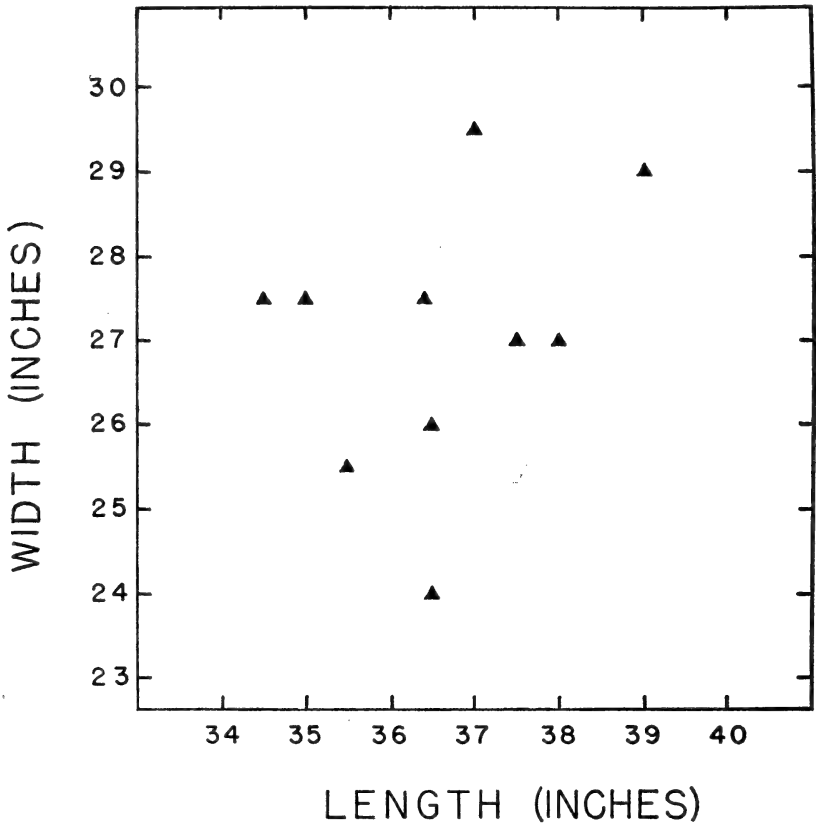

Figure 2. Relationship of carapace length to carapace width in nesting female loggerheads from Hutchinsons Island, Florida.

RANGE-HABITAT

One of the important gaps in the knowledge of sea turtles is a lack of understanding of the range-habitat complex of the several species. In the case of the loggerhead, we know that (1) its breeding range has the greatest northern and least tropical extent of

any of the species and (2) that the non-breeding adults range widely, as solitary individuals (and perhaps peripherally as waifs and strays) throughout the warm and temperate seas of the world. The mainly carnivorous, largely crab-eating, but somewhat omnivorous, habit makes for relatively unrestricted habitat relations, and the willingness to accept nearly any invertebrate food would seem to allow a range extension to limits set naturally only by cold water.

One observation pertinent in this connection was contributed by Dr. E. Lowe Pierce of the Department of Biology, University of Florida. He has noted that in searching for the submerged rocks where he fishes in the Gulf of Mexico at Cedar Key, the blowing of a loggerhead often marks the site of a submerged outcrop. The more tropical elements in the fauna group about these rocks and the communities there presumably include aggregations of crustaceans attractive to the loggerheads. It is of interest that when no loggerheads show up, Dr. Pierce can often locate the 3 to 6 fathom rock bottom by the crackling sound of snapping shrimp under his boat.

Another significant note is that of aqua-lung divers in the Panama City-Pensacola, Florida area who have repeatedly observed loggerheads poking about the old wrecks around which they do their spear fishing and some of which are under as much as a hundred feet of water.

ACKNOWLEDGMENTS

We wish to thank the many people who furthered our studies by supplying information, physical aid, and encouragement. Some of these are: Winfield Brady, Jose A. Suarez Caabro, Marjorie Carr, Thomas Carr, Newt Chase, Edward Crittenden, Jule Gay, Evelyn Hellier, Mary Ann Hellier, Thomas R. Hellier, Sr., A. A. Hendry, Sr., A. A. Hendry, Jr., Phil Hopkins, John D. Kilby, John H. Odum, Larry Ogren, E. Lowe Pierce, the St. Vincents Island Company, J. B. and Marjorie Siebenaler, and Jay A. Schuler.

LITERATURE CITED

CARR, ARCHIE

1952. *Handbook of Turtles*. Comstock Publishing Associates, a division of Cornell University Press, Ithaca, New York. pp. xv + 542.
1956. *The Windward Road*. Alfred A. Knopf, New York. pp. xvi + 258 + viii.

CARR, ARCHIE, and DAVID K. CALDWELL

1956. The ecology and migrations of sea turtles. I. Results of field work in Florida, 1955. *Amer. Mus. Novitates*, in press.

HILDEBRAND, SAMUEL F., and C. HATSEL

1927. On the growth, care and age of loggerhead turtles in captivity. *Proc. Nat. Acad. Sci.*, 13: 374-377.

PARKER, G. H.

1926. The growth of turtles. *Proc. Nat. Acad. Sci.*, 12: 422-424.
1929. The growth of the loggerhead turtle. *Amer. Nat.*, 63: 367-373.

INTERACTION OF Pi^- MESONS WITH LIGHT NUCLEI

Joseph Callaway

University of Miami

Information on the interaction of Pi^- mesons with light nuclei comes from two sources: (1) the displacements of the energy levels in Pi^- mesic atoms from the values predicted by the Klein-Gordon equation for a coulomb potential, and (2) the scattering of these mesons. The displacements of the 1s level in Pi^- mesic atoms have been measured for six elements from the energies of the x-rays corresponding to the 2p-1s transitions.^{1,2} The results indicate an effective repulsion between the Pi^- meson in the 1s state and the nucleus. Predictions of these displacements in rough agreement with experiment have been made, based on the observed scattering amplitudes for Pi^- -p scattering.³ The experimental data are not sufficiently accurate to permit determination of the level width caused by the finite lifetime of the meson in the 1s state. This discussion has the purpose of determining the magnitude of the effective repulsive potential and of relating it to the scattering of mesons by light nuclei.

Since the energy level displacements are reasonably small compared to the energy of the 2p-1s transition as predicted from the Klein-Gordon Equation, the magnitude of the repulsive potential can be computed by first-order perturbation theory from the observed displacement. In this calculation ordinary Schrödinger wave functions can be used because relativistic corrections are small in light elements. If we assume that the interaction can be represented by a square barrier having the radius of the nucleus and of height V_0 we find easily:

$$E = \frac{4}{3} \left(\frac{Z r_0}{a_0} \right)^3 A V_0 \quad (1)$$

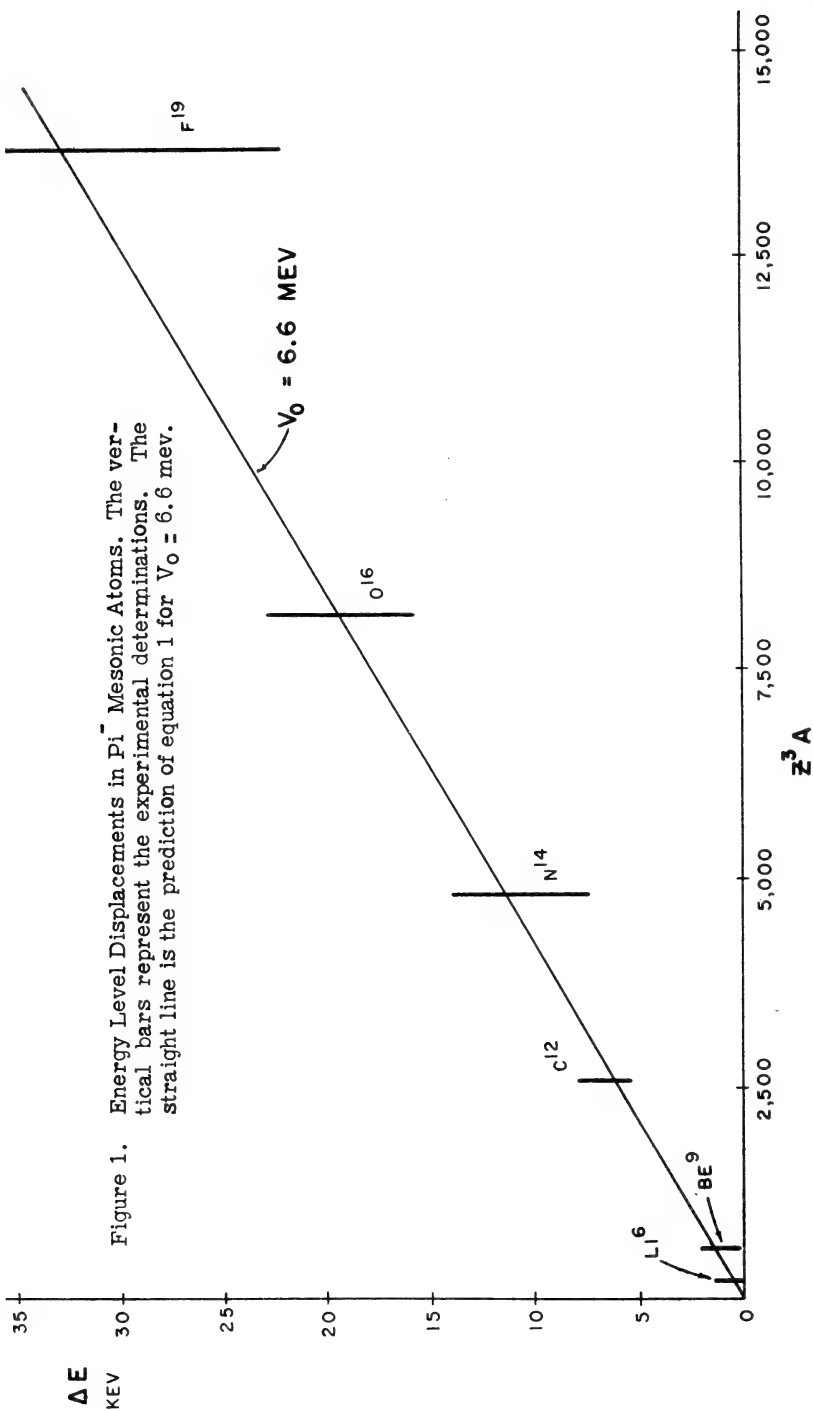

Figure 1. Energy Level Displacements in Pi^- Mesonic Atoms. The vertical bars represent the experimental determinations. The straight line is the prediction of equation 1 for $V_0 = 6.6 \text{ mev}$.

Here the radius of the particular nucleus is assumed to be $r_0 A^{1/3}$; ΔE is the level shift, and a_0 is the meson Bohr radius (1.938×10^{-11} cm). A graph of ΔE against Z^3/A for the six elements Li^6 , Be^9 , C^{12} , N^{14} , O^{16} , F^{19} can be fitted by a straight line within the large experimental uncertainty. The slope of this line gives $V_0 = 6.6 \pm 0.5$ mev. for $r_0 \pm 1.25 \times 10^{-13}$ cm. If we use the treatment of reference 3, we find approximately $V_0 = 6.1$ mev. for this choice of r_0 . To take account of the finite lifetime of the meson, we may add an imaginary part to the potential which could be determined from the width of the 2p-1s x-ray line when measurements are more precise. The estimate of reference 3 would suggest an imaginary part of the potential perhaps one tenth the real part.

The differential cross section for the scattering of Pi^- mesons by carbon has been measured at 62 and 125 mev.^{4,5} This data has been analyzed in terms of the optical model, yielding an attractive potential

$$V = -18 - 9i \text{ (mev)}$$

at the lower energy and a deeper potential at the higher energy.⁴ In order to reconcile the scattering measurements with the result from the Pi^- mesic atom, we may assume that the potential is attractive in p states of the meson about the nucleus while repulsive in s states. A similar situation apparently occurs in Pi^- -p scattering. The optical model potential proposed by Byfield, et al. is then some average of these interactions. Scattering experiments at energies sufficiently low for p wave scattering to be small, if feasible experimentally, should test this hypothesis. It is possible that part of the energy dependence of the optical model parameters⁵ may be explained in terms of differing importance of the various angular momentum states as the energy of the incident meson is varied. The s wave part of the cross section for the scattering of Pi^- mesons on carbon

can be computed from the repulsive potential previously mentioned. A least squares fit to the cross section at 62 mev was made with a function of the form $a + b \cos \theta + c \cos^2 \theta$, and the constant a was compared with the one calculated. The calculated value is somewhat lower than the experimental result although there is a large experimental uncertainty, and would require a stronger interaction than suggested by the mesic atom; perhaps 10 or 15 mev. In addition, there is some indication that the phase shifts for s and p waves have opposite signs, as required by this hypothesis.

In conclusion, we find that observed energy level displacements in light elements can be approximately accounted for by a repulsive square barrier interaction of the meson in the $1s$ state and the nucleus. This assumption is at least qualitatively consistent with present scattering data.

I am indebted to Dr. Roger D. Woods for valuable discussions.

LITERATURE CITED

- 1) M. B. Stearns, M. Stearns, S. De Benedetti; and L. Leipuner, Phys. Rev. 96, 804 (1954).
- 2) M. B. Stearns, M. Stearns, S. De Benedetti; and L. Leipuner, Phys. Rev. 97, 240 (1955).
- 3) S. Deser, M. L. Goldberger, K. Baumann, and W. Thirring, Phys. Rev. 96, 774 (1954).
- 4) H. Byfield, J. Kessler, and L. M. Lederman, Phys. Rev. 86, 17, (1952).
- 5) J. Kessler and L. M. Lederman, Phys, Rev. 94, 689, (1954).

INSTRUCTIONS FOR AUTHORS

Contributions to the *JOURNAL* may be in any of the fields of Sciences, by any member of the Academy. Contributions from non-members may be accepted by the Editors when the scope of the paper or the nature of the contents warrants acceptance in their opinion. Acceptance of papers will be determined by the amount and character of new information and the form in which it is presented. Articles must not duplicate, in any substantial way, material that is published elsewhere. Articles of excessive length, and those containing tabular material and/or engravings can be published only with the cooperation of the author. Manuscripts are examined by members of the Editorial Board or other competent critics.

MANUSCRIPT FORM.—(1) Typewrite material, using one side of paper only; (2) double space *all* material and leave liberal margins; (3) use 8½ x 11 inch paper of standard weight; (4) do not submit carbon copies; (5) place tables on separate pages; (6) footnotes should be avoided whenever possible; (7) titles should be short; (8) method of citation and bibliographic style must conform to *JOURNAL* style—see Volume 16, No. 1 and later issues; (9) a factual summary is recommended for longer papers.

ILLUSTRATIONS.—Photographs should be glossy prints of good contrast. All drawings should be made with India ink; plan linework and lettering for at least ½ reduction. Do not mark on the back of any photographs. Do not use typewritten legends on the face of drawings. Legends for charts, drawings, photographs, etc., should be provided on separate sheets. Articles dealing with physics, chemistry, mathematics and allied fields which contain equations and formulae requiring special treatment should include India ink drawings suitable for insertion in the *JOURNAL*.

PROOF.—Galley proof should be corrected and returned promptly. The original manuscript should be returned with galley proof. *Changes* in galley proof will be billed to the author. Unless specially requested page proof will not be sent to the author. *Abstracts* and *orders for reprints* should be sent to the editor along with corrected galley proof.

REPRINTS.—Reprints should be ordered when galley proof is returned. An order blank for this purpose accompanies the galley proof. The *JOURNAL* does not furnish any free reprints to the author. Payment for reprints will be made by the author directly to the printer.



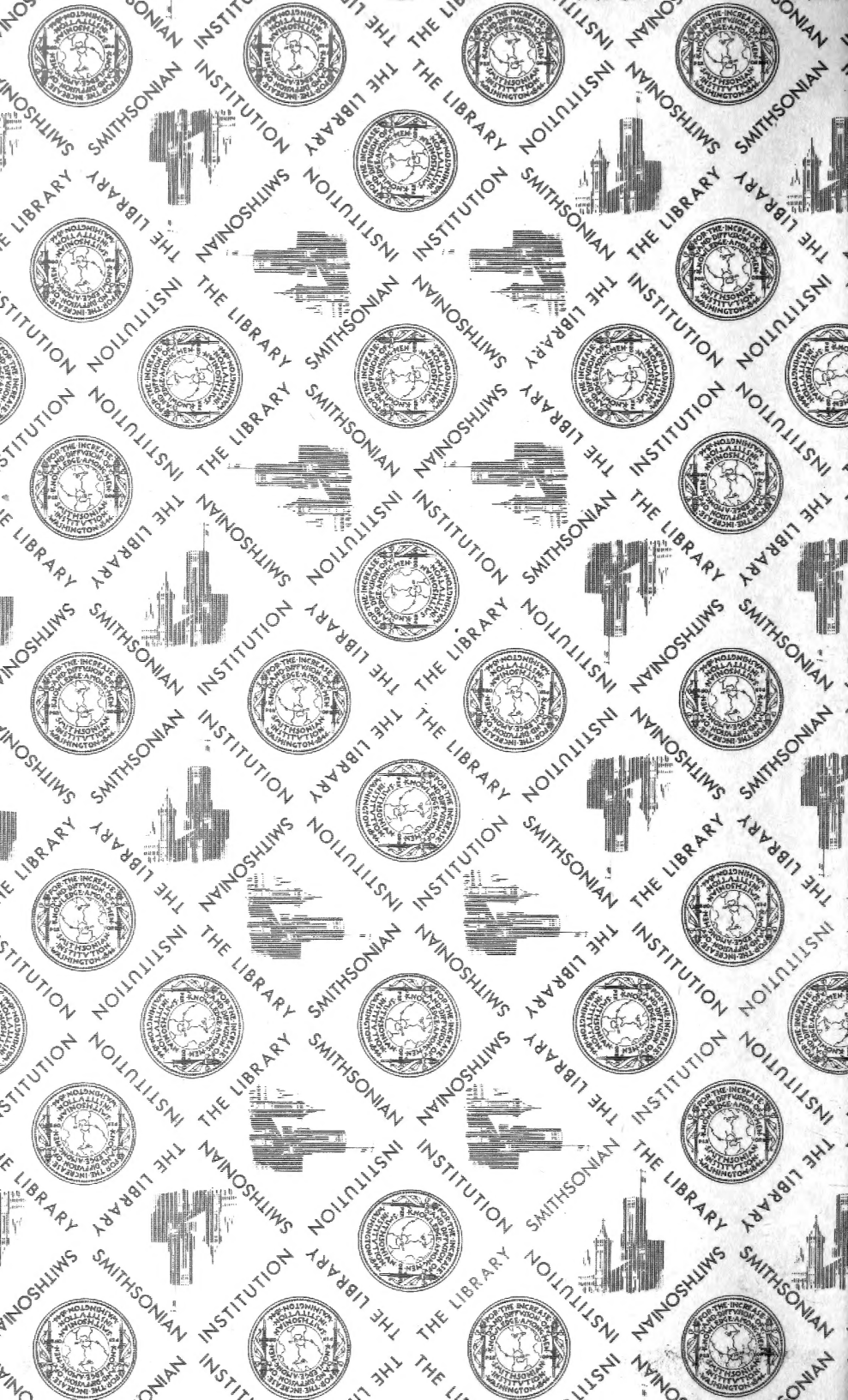

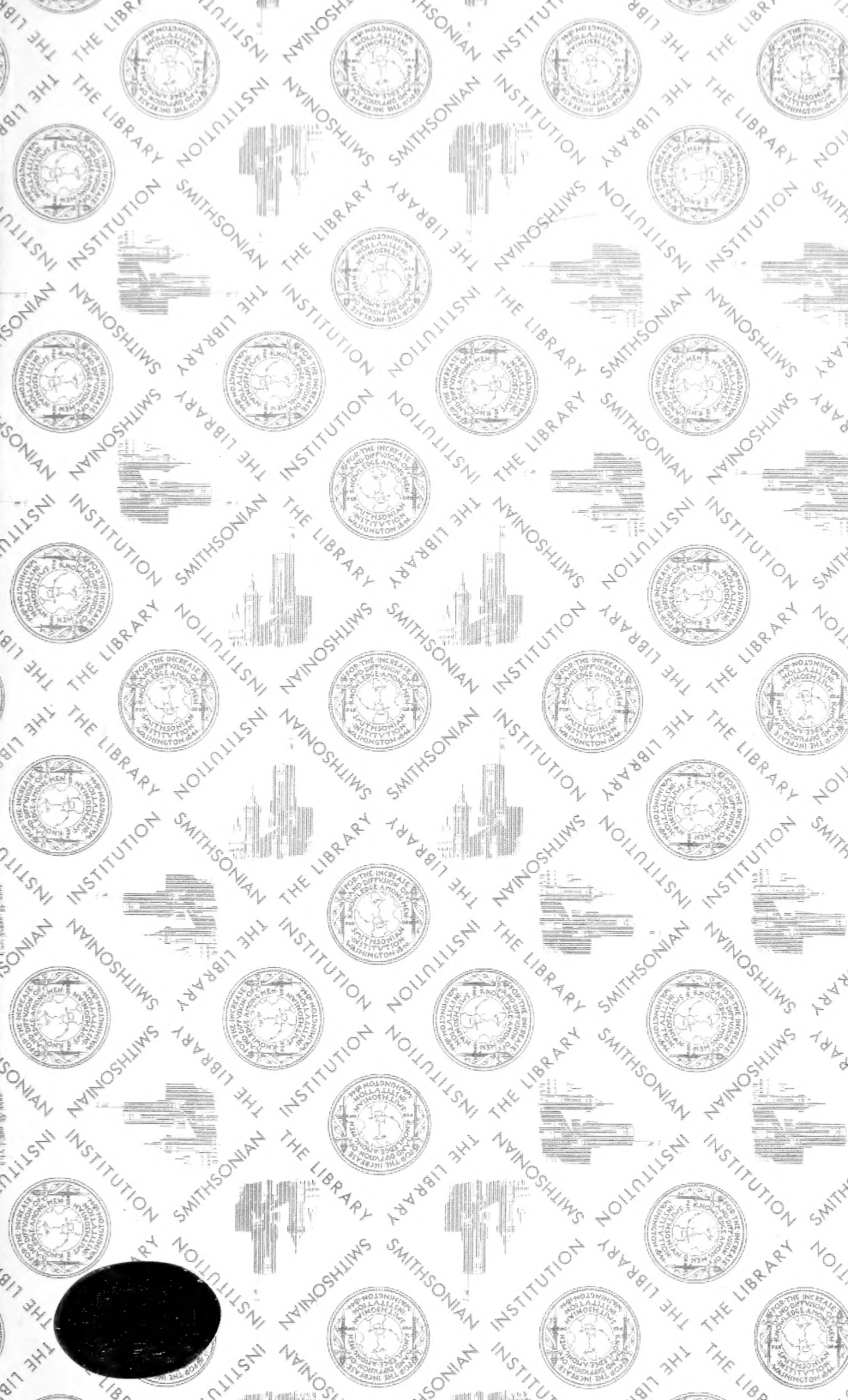

SMITHSONIAN INSTITUTION LIBRARIES



3 9088 90048 2068