

102

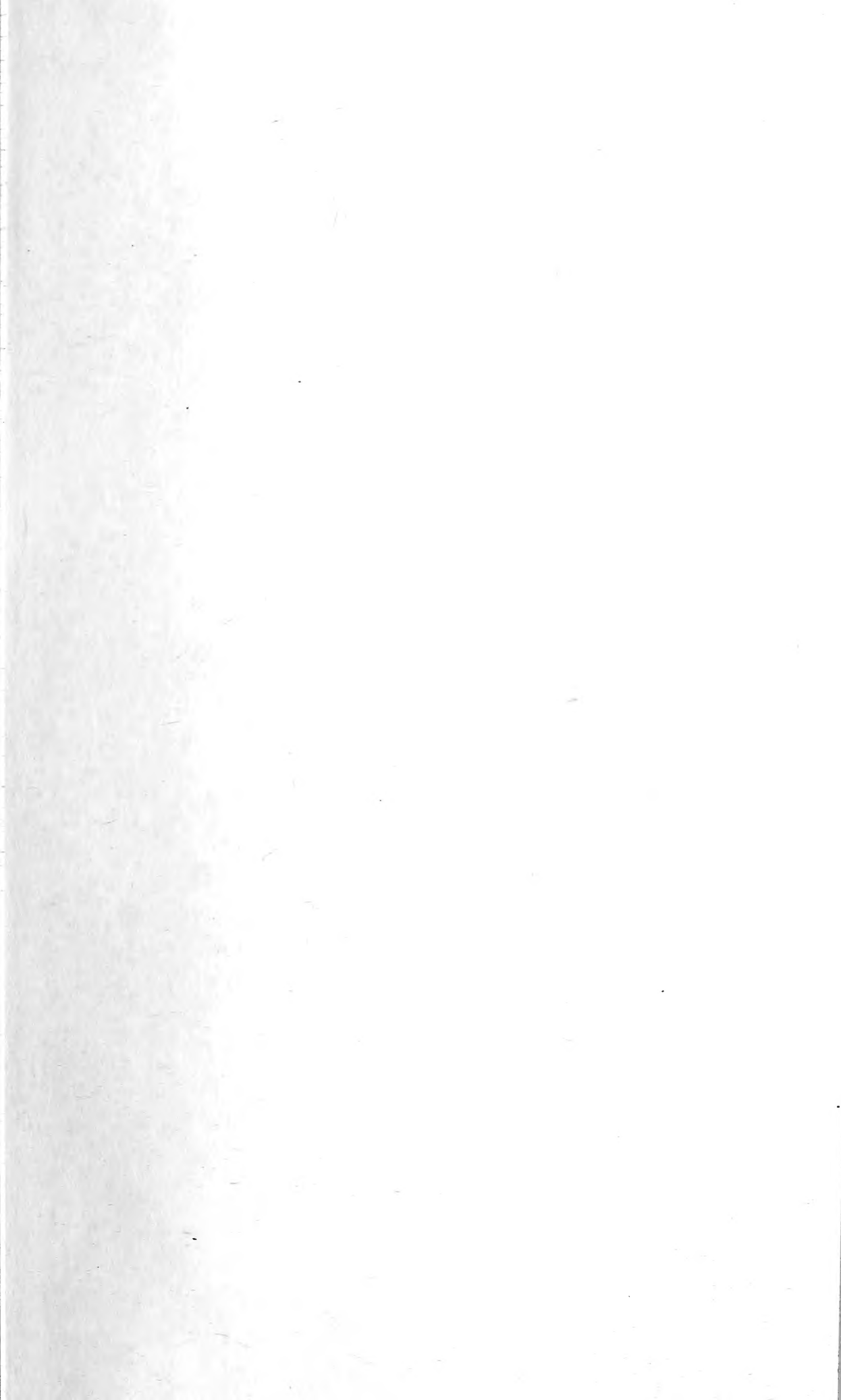



THE
QUARTERLY JOURNAL

OF THE
GEOLOGICAL SOCIETY OF LONDON.

EDITED BY
THE ASSISTANT-SECRETARY OF THE GEOLOGICAL SOCIETY.

Quod si cui mortalium cordi et curæ sit non tantum inventis hæerere, atque iis uti, sed ad ulteriora penetrare; atque non disputando adversarium, sed opere naturam vincere; denique non belle et probabiliter opinari, sed certo et ostensive scire; tales, tanquam veri scientiarum filii, nobis (si videbitur) se adjungant.
—*Novum Organum, Præfatio.*

VOLUME THE FORTY-THIRD.

1887.

LONDON:

LONGMANS, GREEN, AND CO.

PARIS: FRIED. KLINCKSIECK, 11 RUE DE LILLE; F. SAVY, 24 RUE HAUTEFEUILLE.
LEIPZIG: T. O. WEIGEL.

SOLD ALSO AT THE APARTMENTS OF THE SOCIETY.

MDCCCLXXXVII.

List
OF THE
OFFICERS
OF THE
GEOLOGICAL SOCIETY OF LONDON.

~~~~~  
Elected February 18, 1887.  
~~~~~

President.

Prof. J. W. Judd, F.R.S.

Vice-Presidents.

H. Bauerman, Esq.
Prof. T. G. Bonney, D.Sc., F.R.S.

A. Geikie, LL.D., F.R.S.
Henry Woodward, LL.D., F.R.S.

Secretaries.

W. T. Blanford, LL.D., F.R.S.

W. H. Hudleston, Esq., M.A., F.R.S.

Foreign Secretary.

Sir Warrington W. Smyth, M.A., F.R.S.

Treasurer.

Prof. T. Wiltshire, M.A., F.L.S.

COUNCIL.

H. Bauerman, Esq.
W. T. Blanford, LL.D., F.R.S.
Prof. T. G. Bonney, D.Sc., LL.D., F.R.S.
Thomas Davies, Esq.
Prof. P. M. Duncan, M.B., F.R.S.
A. Geikie, LL.D., F.R.S.
Henry Hicks, M.D., F.R.S.
Rev. Edwin Hill, M.A.
W. H. Hudleston, Esq. M.A., F.R.S.
Prof. T. McKenny Hughes, M.A.
J. W. Hulke, Esq., F.R.S.
Prof. T. Rupert Jones, F.R.S.

Prof. J. W. Judd, F.R.S.
R. Lydekker, Esq., B.A.
J. E. Marr, Esq., M.A.
E. Tulley Newton, Esq.
Prof. H. G. Seeley, F.R.S.
Sir Warrington W. Smyth, M.A., F.R.S.
J. J. H. Teall, Esq., M.A.
Rev. G. F. Whidborne, M.A.
Prof. T. Wiltshire, M.A., F.L.S.
Rev. H. H. Winwood, M.A.
Henry Woodward, LL.D., F.R.S.

Assistant-Secretary, Clerk, Librarian, and Curator.
W. S. Dallas, Esq., F.L.S.

Assistants in Office, Library, and Museum.
Mr. W. Rupert Jones.
Mr. Francis E. Brown.



21 DEC. 87
(T. & C^o)

TABLE OF CONTENTS.

	Page
BONNEY, Prof. T. G. Notes on the Structures and Relations of some of the Older Rocks of Brittany. (Plate XVII.)	301
BRODIE, Rev. P. B. Notes on the Upper Keuper Section at Shrewley where Fish were found, and on the Trias generally in Warwickshire	540
CALLAWAY, C., Esq. On the Alleged Conversion of Crystalline Schists into Igneous Rocks in County Galway	517
———. A Preliminary Inquiry into the Genesis of the Crystalline Schists of the Malvern Hills.	525
DAVID, T. W. EDGWORTH, Esq. Evidence of Glacial Action in the Carboniferous and Hawkesbury Series, New South Wales	190
DAVIS, JAMES W., Esq. On <i>Chondrosteus acipenseroides</i> , Agassiz. (Plate XXIII.)	605
DERBY, ORVILLE A., Esq. On Nepheline-Rocks in Brazil, with Special Reference to the Association of Phonolite and Foyaite .	457
DONALD, Miss JANE. Notes upon some Carboniferous Species of <i>Murchisonia</i> in our Public Museums. (Plate XXIV.)	617
DUNCAN, Prof. P. MARTIN. On a new Genus of Madreporaria (<i>Glyphastræa</i>), with Remarks on the Morphology of <i>Glyphastræa Forbesi</i> , Ed. & H., from the Tertiaries of Maryland, U. S. (Plate III.)	24
———. On the Echinoidea of the Cretaceous Strata of the Lower Narbadá Region	150

	Page
DUNCAN, Prof. P. MARTIN. A Revision of the Echinoidea from the Australian Tertiaries	411
ELSDEN, J. VINCENT, Esq. On the Superficial Geology of the Southern Portion of the Wealden Area	637
GARDNER, J. STARKIE, Esq. On the Leaf-beds and Gravels of Ardtun, Carsaig, &c., in Mull. (Plates XIII.-XVI.)	270
GRESLEY, W. S., Esq. Notes on the Formation of Coal-seams, as suggested by evidence collected chiefly in the Leicestershire and South Derbyshire Coal-fields.....	671
GROOM, T. T., Esq. On some new Features in <i>Pelanechinus coralinus</i> . (Plate XXVIII.)	703
HILL, Rev. E. The Rocks of Sark, Herm, and Jethou	322
HILL, W., Esq., and A. J. JUKES-BROWNE, Esq. On the Lower Part of the Upper Cretaceous Series in West Suffolk and Norfolk ..	544
HUDLESTON, W. H., Esq. Supplementary Note on the Walton-Common Section	443
HUGHES, Prof. T. McKENNY. On the Drifts of the Vale of Clwyd and their Relation to the Caves and Cave-deposits. (Plate IX.)	73
———. On the Ancient Beach and Boulders near Braunton and Crojde in North Devon	657
HULKE, J. W., Esq. Note on some Dinosaurian Remains in the Collection of A. Leeds, Esq., of Eyebury, Northamptonshire ..	695
HUTTON, Capt. F. W. The Eruption of Mount Tarawera	178
HUXLEY, Prof. T. H. Further Observations upon <i>Hyperodapedon Gordoni</i> . (Plates XXVI., XXVII.)	675
IRVING, Rev. A. The Physical History of the Bagshot Beds of the London Basin	374
JONES, Prof. T. RUPERT. Note on <i>Nummulites elegans</i> , Sowerby, and other English Nummulites. (Plate XI.).....	132
JUKES-BROWNE, A. J., Esq., and W. HILL, Esq. On the Lower Part of the Upper Cretaceous Series in West Suffolk and Norfolk ..	544
KOTÔ, Prof. BUNDJIRO. On some Occurrences of Piedmontite-Schist in Japan	474
LYDEKKER, R., Esq. The Cetacea of the Suffolk Crag. (Plate II.)	

	Page
LYDEKKER, R., Esq. Description of a Jaw of <i>Hyotherium</i> from the Pliocene of India	19
———. On certain Dinosaurian Vertebræ from the Cretaceous of India and the Isle of Wight	156
———. On a Molar of a Pliocene Type of <i>Equus</i> from Nubia	161
LYONS, H. G., Esq. On the London Clay and Bagshot Beds of Aldershot	431
MARTIN, JOSIAH, Esq. The Terraces of Rotomahana	165
NEWTON, E. T., Esq. On the Remains of Fishes from the Keuper of Warwick and Nottingham; with Notes on the Mode of Occurrence by the Rev. P. B. BRODIE, M.A., F.G.S., and EDW. WILSON, Esq., F.G.S. (Plate XXII.)	537
OWEN, SIR RICHARD. On the Skull and Dentition of a Triassic Saurian (<i>Galesaurus planiceps</i> , Ow.). (Plate I.)	1
PRESTWICH, Prof. JOSEPH. Considerations on the Date, Duration, and Conditions of the Glacial Period, with reference to the Antiquity of Man	393
RADCLIFFE, JAMES, Esq. On Grooves and Quartzite Boulders in the Roger Mine at Dukinfield	599
RAISIN, Miss CATHERINE A. Notes on the Metamorphic Rocks of South Devon	715
REID, CLEMENT, Esq. On the Origin of Dry Chalk Valleys and of Coombe Rock	364
ROBERTS, THOMAS, Esq. On the Correlation of the Upper Jurassic Rocks of the Swiss Jura with those of England	229
ROWE, Rev. A. W. On the Rocks of the Essex Drift	351
RUTLEY, FRANK, Esq. On the Rocks of the Malvern Hills. (Plates XIX.-XXI.)	481
SEELEY, Prof. H. G. On a Sacrum, apparently indicating a new type of Bird, <i>Ornithodesmus clunicultus</i> , Seeley, from the Wealden of Brook. (Plate XII.)	206
———. On <i>Heterosuchus valdensis</i> , Seeley, a Procelian Crocodile from the Hastings Sand of Hastings. (Plate XII.)	212
———. On <i>Patricosaurus merocratus</i> , Seeley, a Lizard from the Cambridge Greensand, preserved in the Woodwardian Museum of the University of Cambridge. (Plate XII.)	216

	Page
SEELEY, Prof. H. G. On <i>Aristosuchus pusillus</i> (Owen), being Further Notes on the Fossils described by Sir R. Owen as <i>Poikilopleuron pusillus</i> , Owen	221
SPENCER, JOHN, Esq. On Boulders found in Seams of Coal	734
THOMSON, JAMES, Esq. On the Occurrence of Species of the Genus <i>Diphyphyllum</i> , Lonsdale, in the Lower Carboniferous Strata of Scotland, with a Description of some new Species and Notices of Varieties. (Plates IV., V.)	33
WALFORD, EDWIN A., Esq. Notes on some Polyzoa from the Lias. (Plate XXV.)	632
WATERS, ARTHUR WM., Esq. On Tertiary Chilostomatous Bryozoa from New Zealand. (Plates VI.-VIII.)	40
———. On Tertiary Cyclostomatous Bryozoa from New Zealand. (Plate XVIII.)	337
WHITAKER, WILLIAM, Esq. Further Notes on the Results of some Deep Borings in Kent	197
WILSON, EDW., Esq. Notes on the Triassic Beds at Colwick Wood, near Nottingham	542
WOODWARD, A. SMITH, Esq. On the Dentition and Affinities of the Selachian Genus <i>Ptychodus</i> , Agassiz. (Plate X.)	121

 PROCEEDINGS.

Annual Report.....	8
List of Foreign Members	17
List of Foreign Correspondents	18
List of Wollaston Medallists	19
List of Murchison Medallists	21
List of Lyell Medallists	22
List of Bigsby Medallists	23
Applications of the Barlow-Jameson Fund	23
Financial Report.....	24

TABLE OF CONTENTS.

vii

	Page
Award of the Medals &c.	30
Anniversary Address	38
Donations to the Library (with Bibliography)	92

BARKLY, Sir ARTHUR. Letter on the Slip of a Peat-Bog in the Falkland Islands	2
ULRICH, Prof. Notice of his discovery of a peculiar alloy of Iron and Nickel in New-Zealand Rocks	3
STANLEY, W. F., Esq. On the probable amount of former Glaciation of Norway, as demonstrated by the present condition of Rocks upon and near the Western Coast	83
“ Société Ouralienne d'Amateurs des Sciences Naturelles,” notice by the President of an exhibition to be held by the, at Ekaterinebourg	86

LIST OF THE FOSSILS FIGURED AND DESCRIBED IN THIS VOLUME.

[In this list, those fossils the names of which are printed in Roman type have been previously described.]

Name of Species.	Formation.	Locality.	Page.
------------------	------------	-----------	-------

PLANTÆ.

<p>Acer, sp. Pl. xiv. f. 1</p> <p>Betula? Pl. xvi. f. 4.....</p> <p><i>Bœhmeria antiqua</i>. Pl. xv. f. 1 ...</p> <p>Corylites Macquarrii. Pl. xv. f. 3.</p> <p>Glyptostrobus europæus. Pl. xiii. f. 2.</p> <p>Myrtaceæ, supposed leaves of. Pl. xvi. f. 2, 3, 5</p> <p>Platanus hebridicus. Pl. xiii. f. 12-15</p> <p><i>Podocarpus borealis</i>. Pl. xiii. f. 3.</p> <p>Quercites grœnlandicus. Pl. xiv. f. 2</p> <p>Sequoia Langsdorfii. Pl. xiii. f. 1.</p> <p>Undetermined leaves. Pl. xiv. f. 3; Pl. xv. f. 2; Pl. xvi. f. 1</p>	<p>Leaf-beds</p>	<p>Mull</p>	<p>290</p> <p>290</p> <p>291</p> <p>290</p> <p>289</p> <p>291</p> <p>289</p> <p>289</p> <p>291</p> <p>289</p> <p>291</p>
---	------------------------	-------------------	--

PROTOZOA.

(*Foraminifera*.)

<p>Nummulites elegans. Pl. xi. f. 1-9. }</p> <p>— lævigatus</p> <p>— variolarius. Pl. xi. f. 10-14. }</p>	<p>Eocene.....</p>	<p>England</p>	<p>142</p> <p>147</p> <p>145</p>
---	--------------------	----------------------	----------------------------------

Name of Species.	Formation.	Locality.	Page.	
CŒLEENTERATA.				
(<i>Actinozoa.</i>)				
<i>Diphyphyllum Blackwoodi.</i> Pl. iv. f. 3	Carboniferous ...	Scotland	36	
— —, var. <i>approximatum.</i> Pl. iv. f. 4				36
— <i>concinnum.</i> Pl. iv. f. 1				35
— —, var. <i>furcatum.</i> Pl. iv. f. 2				36
— <i>cylindricum.</i> Pl. iv. f. 5				36
— <i>gracile.</i> Pl. v. f. 10				37
— <i>latiseptatum.</i> Pl. v. f. 6				37
— —, var. <i>giganteum.</i> Pl. v. f. 7, 8				37
— —, var. <i>interruptum.</i> Pl. v. f. 9				37
<i>Glyphastræa Forbesi.</i> Pl. iii.				Tertiary
ECHINODERMATA.				
<i>Catopygus elegans</i>	Tertiary	Australia	420	
<i>Cidaris (Leiocidaris), sp.</i>				412
<i>Clypeaster folium</i>				415
— <i>gippslandicus</i>				416
<i>Echinolampas ovulum</i>				420
<i>Euspatangus Laubei</i>				426
— <i>murrayensis</i>				426
— <i>rotundus.</i>				426
<i>Holaster australiæ.</i> Fig.				420
— <i>difficilis</i>				421
<i>Lovenia Forbesi</i>				424
<i>Maretia anomala.</i>				422
<i>Megalaster compressus</i>				422
<i>Micraster brevistella</i>				421
<i>Ortholophus lineatus</i>				413
<i>Paradoxechinus novus</i>	415			
<i>Pelanechinus corallinus.</i> Pl. xxviii.	Oolite	England	704	
<i>Pericosmus compressus</i>	Tertiary	Australia	423	
— <i>gigas</i>				423
<i>Psammechinus Woodsi</i>				413
<i>Salenia tertiaria</i>			412	
POLYZOA.				
<i>Cellepora albirostris</i>	Tertiary	New Zealand ...	68	
— <i>coronopus</i>				68
— <i>costata</i>				68
— <i>decepta.</i> Pl. viii. f. 33				69
— <i>tridenticulata.</i>				68
—, sp.				70
<i>Cinctipora elegans</i>				341
<i>Crassohornera waipukurensis.</i> Pl. xviii. f. 2, 3, 4, 9				349
<i>Cribrilina figularis</i>				53
— <i>monoceros</i>				52
— <i>radiata, var. Endlicheri.</i>	53			

Name of Species.	Formation.	Locality.	Page.
POLYZOA (<i>continued</i>).			
<i>Crisina cancellata</i> . Pl. xviii. f. 8, 11			349
<i>Diastopora sarniensis</i> , var. <i>peran-</i> <i>gusta</i>			342
— <i>suborbicularis</i>			342
<i>Entalophora intricaria</i> . Pl. xviii. f. 5, 6			340
— <i>wanganuiensis</i> . Pl. xviii. f. 1			340
<i>Fascicularia tubipora</i>			344
<i>Heteropora napiensis</i>			348
— <i>pelliculata</i>			348
<i>Idmonea contorta</i>			339
— <i>ramosa</i>			339
— <i>serpens</i>			339
<i>Lepralia bistata</i> . Fig. 1			62
— <i>foraminigera</i>			62
— <i>imbellis</i>			60
— <i>longipora</i>			61
— <i>Poissonii</i> . Pl. viii. f. 37			59
— <i>rectilineata</i> . Pl. vii. f. 16; Pl. viii. f. 34–36			60
— <i>rostrigera</i> . Pl. vii. f. 17			61
— <i>semiluna</i> , var. <i>simplex</i> . Pl. vii. f. 19			62
<i>Lichenopora boletiformis</i>			347
— <i>clypeiformis</i>			345
— <i>Houldsworthii</i>			347
— <i>wanganuiensis</i> . Fig.	Tertiary	New Zealand ...	346
<i>Lunulites petaloides</i>			70
<i>Membranipora annulus</i> . Pl. vi. f. 2, 5, 9			47
— <i>Dumerilii</i> . Pl. vi. f. 4			45
— <i>Lacroixii</i> , var. <i>grandis</i> . Pl. vi. f. 1			45
— <i>lineata</i>			45
— <i>monostachys</i> . Pl. vi. f. 3, 6... ..			45
— <i>nobilis</i> . Pl. vi. f. 7, 10			46
— <i>occultata</i> . Pl. vi. f. 12, 13; Pl. viii. f. 40.....			48
— <i>solidula</i>			46
— <i>spinosa</i> . Pl. viii. f. 32.....			48
— <i>trifolium</i>			48
<i>Membraniporella nitida</i> . Pl. vii. f. 18.....			52
<i>Micropora variperforata</i> . Pl. viii. f. 27.....			51
<i>Microporella ciliata</i>			53
— <i>decorata</i> , var. <i>angustipora</i> ...			54
— ? <i>macropora</i>			54
— <i>magnirostris</i>			55
<i>Monoporella capensis</i>			49
—, var. <i>dentata</i> . Pl. viii. f. 39.....			49
— <i>crassatina</i> . Pl. vii. f. 15			49

Name of Species.	Formation.	Locality.	Page.		
POLYZOA (<i>continued</i>).					
Monoporella disjuncta. Pl. vi. f. 8	Tertiary	New Zealand	50		
— <i>waipukurensis</i> . Pl. vi. f. 11			50		
Mucronella ? <i>alvareziana</i> . Pl. vii. f. 24, 25			57		
— <i>firmata</i> . Pl. vii. f. 20			58		
— ? <i>Liversidgei</i>			58		
— <i>nitida</i>			55		
— <i>Peachii</i> , var. <i>octodentata</i>			56		
— <i>porosa</i> , var. <i>minima</i> . Pl. viii. f. 31			57		
— <i>præstans</i>			56		
— <i>tricuspis</i>			57		
— var. <i>waipukurensis</i> . Pl. viii. f. 30			57		
Porella <i>concinna</i>			63		
<i>Porina grandipora</i> . Pl. vii. f. 23			59		
<i>Reptocavea aspera</i> . Pl. xxviii. f. 10, 13			347		
Rhynchopora <i>longirostris</i> . Pl. vii. f. 22			70		
Schizoporella <i>cinctipora</i> , var. <i>personata</i> . Pl. viii. f. 28			67		
— <i>circinata</i> . Pl. viii. f. 41			64		
— <i>clavula</i>			65		
— <i>conservata</i> . Pl. vii. f. 21			65		
— <i>hyalina</i> . Pl. viii. f. 42, 43			68		
— <i>obliqua</i> ? Fig. 2			66		
— <i>Ridleyi</i>			64		
— <i>tuberosa</i> , var. <i>angustata</i> . Pl. viii. f. 26			67		
Smittia <i>biincisa</i> , var. <i>bicuspis</i>			58		
— <i>Napierii</i>			59		
Steganoporella <i>neozelanica</i>			50		
<i>Stomatopora elongata</i> . Pl. xxv. f. 10			Lias	England	636
— <i>granulata</i>			}	}	341
— <i>major</i>					342
Supercyrtis <i>digitata</i>					344
<i>Tubulipora biduplicata</i> . Pl. xviii. f. 12, 14			Tertiary	New Zealand	343
— <i>Campicheana</i> . Pl. xviii. f. 15			}	}	343
— <i>dimidiata</i>					343
— <i>inconstans</i> . Pl. xxv. f. 1-9, 12					Lias
— ? <i>sp.</i> Pl. xxv. f. 11			}	}	635

ANNULOSA.

(*Insecta.*)

Beetle, elytron of. Pl. xiii. f. 8	} Leaf-beds	} Mull.	289
Cercopid, wing of. Pl. xiii. f. f. 9			289

Name of Species.	Formation.	Locality.	Page.	
MOLLUSCA.				
(<i>Gasteropoda.</i>)				
Murchisonia angulata. Pl. xxiv. f. 1, 2	Carboniferous ...	Britain	621	
— kendalensis. Pl. xxiv. f. 3-5...				625
— pyramidata. Pl. xxiv. f. 9 ...				627
— sphaerulata. Pl. xxiv. f. 10 ...				629
— tenuissima. Pl. xxiv. f. 11 ...				629
— Verneuiliana. Pl. xxiv. f. 6-8				626
— zonata. Fig.....			628	
Turritella ? sulcifera. Pl. xxiv. f. 12	Carboniferous ...	Ireland.....	630	

VERTEBRATA.

(*Pisces.*)

Chondrosteus acipenseroides. Pl. xxiii.	Lias	Lyme Regis.....	605	
Palæoniscoid scales. Pl. xxii. f. 9...	Keuper.....	Nottingham.....	539	
Ptychodus decurrens. Pl. x. f. 1-10, 13	Cretaceous	England	123	
— paucisulcatus. Pl. x. f. 12 ...				127
— polygyrus. Pl. x. f. 11.....				127
<i>Semionotus Brodiei.</i> Pl. xxii. f. 1-7	Keuper.....	Warwickshire ...	539	
— sp. Pl. xxii. f. 8	Keuper.....	Nottingham.....	539	

(*Reptilia.*)

<i>Aristosuchus pusillus.</i> Pl. xii. f. 13, 14.....	Wealden	Isle of Wight ...	221
<i>Galesaurus planiceps.</i> Pl. i.....	Trias	South Africa ...	1
<i>Heterosuchus valdensis.</i> Pl. xii. f. 7, 8	Hastings Sand .	Hastings	212
<i>Hyperodapedon Gordoni.</i> Pl. xxvi.	Trias	Britain.....	675
<i>Omosaurus durobrivensis</i>	Kimmeridge ..	Britain.....	699
<i>Ornithopsis Leedsii.</i>	Kimmeridge ..	Britain.....	697
— ? sp. Fig.....	Wealden	Isle of Wight ...	156
<i>Patricosaurus merocratus.</i> Pl. xii. f. 9-12.....	Greensand	Cambridge	216
<i>Rhynchosaurus articeps.</i> Pl. xxvii.	Trias	Britain.....	699

(*Aves.*)

<i>Ornithodesmus cluniculus.</i> Pl. xii. f. 1-6	Wealden	Isle of Wight ...	206
--	---------------	-------------------	-----

Name of Species.	Formation.	Locality.	Page.
------------------	------------	-----------	-------

(Mammalia.)

Balæna primigenia. Fig. 1 & Pl. ii. f. 1, 2	Crag.....	Suffolk.....	8
Balænoptera definita. Pl. ii. f. 3 ...			11
Choniziphius planirostris. Pl. ii. f. 7			14
Equus, sp. Fig.....	Pliocene	India	161
Eucetus amblyodon. Fig. 2	Crag.....	Suffolk.....	13
Globicephalus uncidens. Pl. ii. f. 11			16
<i>Hyotherium perimense</i> . Fig.	Pliocene	India	19
Hyperoodon, sp. Pl. ii. f. 6.....	Crag.....	Suffolk.....	14
Megaptera affinis. Pl. ii. f. 4			11
— minuta. Pl. ii. f. 5			11
Mesoplodon longirostris? Pl. ii. f. 8	Crag.....	Suffolk.....	15
Orca citoniensis. Pl. ii. f. 9, 10 ...)			16

EXPLANATION OF THE PLATES.

PLATE	PAGE
I. {	SKULL OF GALES SAURUS PLANICEPS, to illustrate Sir R. Owen's paper on that fossil 1
II. {	CETACEAN OOLITHS, &c., to illustrate Mr. R. Lydekker's paper on the Cetacea of the Suffolk Crag 7
III. {	GLYPHASTREA FORBESI, to illustrate Prof. P. M. Duncan's paper on that fossil 24
IV. {	SPECIMENS OF DIPHYPHYLLUM, to illustrate Mr. James Thomson's paper on that genus 33
V. {	
VI. } VII. } VIII. }	TERTIARY CHILOSTOMATOUS BRYOZOA FROM NEW ZEALAND, to illustrate Mr. A. W. Waters's paper on those fossils ... 40
IX. {	STONE IMPLEMENTS FROM PONTNEWYDD CAVE, to illustrate Prof. T. McK. Hughes's paper on the Drifts and Caves of the Vale of Clwyd 73
X. {	DENTITION OF PTYCHODUS, to illustrate Mr. A. S. Woodward's paper on that genus 121
XI. {	ENGLISH NUMMULITES, to illustrate Prof. T. Rupert Jones's paper on those fossils 132
XII. {	ORNITHODESMUS CLUNICULUS, HETEROSUCHUS VALDENSIS, PATRICOSAURUS MEROCRATUS, and ARISTOSUCHUS PUSILLUS, to illustrate Prof. H. G. Seeley's papers on those fossils. 206, 212 216, 221
XIII. } XIV. } XV. } XVI. }	FOSSIL LEAVES &c. FROM ARDTUN, to illustrate Mr. J. S. Gardner's paper on the Leaf-beds and Gravels of Mull ... 270
XVII. {	MICROSCOPIC SECTIONS OF BANDED GNEISS, to illustrate Prof. T. G. Bonney's paper on the Older Rocks of Brittany..... 301
XVIII. {	TERTIARY CYCLOSTOMATOUS BRYOZOA FROM NEW ZEALAND, to illustrate Mr. A. W. Waters's paper on those fossils 337
XIX. } XX. } XXI. }	MICROSCOPIC ROCK-SECTIONS, to illustrate Mr. F. Rutley's paper on the Rocks of the Malvern Hills 481

PLATE	PAGE
XXII. { TRIASSIC FISH-REMAINS, to illustrate Mr. E. T. Newton's paper on Fishes from the Keuper of Warwick and Not- tingham	537
XXIII. { CHONDROSTEUS ACIPENSEROIDES, to illustrate Mr. J. W. Davis's paper on that fossil	605
XXIV. { CARBONIFEROUS MURCHISONIÆ, to illustrate Miss Donald's paper on those fossils.....	617
XXV. { LIASSIC POLYZOA, to illustrate Mr. E. A. Walford's paper on those fossils	632
XXXVI. { REMAINS OF HYPERODAPEDON GORDONI and RHYNCHOSAURUS XXXVII. { ARTICEPS, to illustrate Prof. Huxley's paper on the former species	675
XXVIII. { PEDICELLARIÆ OF PELANECHINUS, to illustrate Mr. T. T. Groom's paper on <i>Pelanechinus corallinus</i>	703

ERRATA ET CORRIGENDA.

- Pages 40-68, *passim*, for "Trig's Station" read "Trigonometrical Station."
Page 519, Explanation of figure, for "Fig. 1" read "Fig. 2."
Page 520, Explanation of upper figure, for "Fig. 2" read "Fig. 1."
Page 520, Explanation of Fig. 3. for "Section" read "Plan."
Page 528, line 16, after "breadth" add "of a large block of it."
Page 542, line 2, for "Worcestershire" read "Warwickshire."



PROCEEDINGS

OF THE

GEOLOGICAL SOCIETY OF LONDON.

SESSION 1886-87.

November 3, 1886.

Prof. J. W. JUDD, F.R.S., President, in the Chair.

The List of Donations to the Library was read.

The following communications were read:—

1. "On the Skull and Dentition of a Triassic Saurian, *Galesaurus planiceps*, Ow." By Sir Richard Owen, K.C.B., F.R.S., F.G.S., &c.

2. "The Cetacea of the Suffolk Crag." By R. Lydekker, Esq., B.A., F.G.S., &c.

3. "On a Jaw of *Hyotherium* from the Pliocene of India." By R. Lydekker, Esq., B.A., F.G.S., &c.

The following specimens were exhibited:—

Cast of *Galesaurus planiceps*, Ow., exhibited by Dr. H. Woodward, F.R.S., F.G.S., in illustration of Sir R. Owen's paper.

A portion of head of *Galesaurus planiceps*, Ow., from Kuisementfontein, Caledon-river District, Orange Free State. Collected by — Hatting, Esq., and exhibited by Prof. T. Rupert Jones, F.R.S., F.G.S., on behalf of C. S. Orpen, Esq., Smithfield, O.F.S.

Specimens of Cetacean Ear-bones from the Suffolk and Antwerp Crags, and a portion of the Jaw of *Hyotherium* from the Pliocene of India, exhibited by R. Lydekker, Esq., B.A., F.G.S., in illustration of his papers.

Map of the Mountain Region of British Honduras, scale 4 millimetres = 1 mile, showing the Geological features of the riparian districts, by C. H. Wilson, Esq., F.G.S.

November 17, 1886.

Prof. J. W. JUDD, F.R.S., President, in the Chair.

The List of Donations to the Library was read.

The Secretary announced that the following type specimens had been bequeathed to the Society's Museum by the late Caleb Evans, Esq., F.G.S., viz. :—*Palæocorystes glabra*, H. Woodw. (Quart. Journ. Geol. Soc. xxvii. p. 90), and *Litoricola glabra*, H. Woodw. (Quart. Journ. Geol. Soc. xxix. p. 29), from the Lower Eocene of Portsmouth; also two specimens of elytra of Beetles from the London Clay of Peckham.

The following communications were read :—

1. A letter from the Lieutenant-Governor of the Falkland Islands, communicated by H.M. Secretary of State for the Colonies :—

“ Government House,
Stanley, Falkland Islands,
3rd June, 1886.

“ MY LORD,—I regret to have to report that a slip of the peat-bog at the back of the town of Stanley, similar to that which occurred in November 1878 *, but about two hundred yards to the westward of the scene of that accident, took place last night. A stream of half-liquid peat, over a hundred yards in width, and 4 or 5 feet deep, flowed suddenly through the town into the harbour, blocking up the streets, wrecking one or two houses in its path, and surrounding others so as completely to imprison the inhabitants. Fortunately, as the night was wet and stormy, almost everyone was within doors, and the few who were in the wrecked houses escaped in time. One child was, unfortunately, smothered in the peat, whose body has been recovered, but no other casualties are known to have occurred. An old man is, however, reported to be missing this morning, and it is feared he may also have perished, as part of his house is almost filled with peat. * * * * The slip was caused, apparently, by the unusually heavy rains which have fallen during the last few days, and which the drains constructed by Mr. Bailey, the Surveyor, in 1878, proved insufficient to carry off. Deeper and wider cuttings will now be made, and I trust that the recurrence of any similar catastrophe may thus be prevented. The town of Stanley is, however, from its situation and the mass of peat-bog on the high ground behind it, always to some extent exposed to danger of this nature in times of unusually heavy rainfall.

“ I have &c.,

“ (Signed)

ARTHUR BARKLY.”

“ *The Right Hon. Earl Granville, K.G.,*

&c. &c. &c.”

* See Quart. Journ. Geol. Soc. vol. xxxv. Proc. p. 96.

2. "On the Drifts of the Vale of Clwyd, and their relation to the Caves and Cave-deposits." By Prof. T. McKenny Hughes, M.A., F.G.S.

The following specimens were exhibited:—

Implements and specimens from Drift-deposits, exhibited by Prof. T. McKenny Hughes, M.A., F.G.S., in illustration of his paper.

Specimens of Metamorphic Rocks from the Malvern Hills, exhibited by Frank Rutley, Esq., F.G.S.

Specimens illustrating Metamorphism in Lizard Gabbros, exhibited by J. J. H. Teal, Esq., M.A., F.G.S.

December 1, 1886.

Prof. J. W. JUDD, F.R.S., President, in the Chair.

Henry Howe Arnold-Bemrose, Esq., M.A., Lonsdale Place, Derby ; Richard Assheton, Esq., B.A., Downham Hall, Clitheroe ; Francis Arthur Bather, Esq., B.A., Redhouse, Roehampton, S.W. ; Rev. Joseph Campbell, M.A., Parsonage, Glen Innes, New England, N. S. Wales ; John Wesley Carr, Esq., B.A., University College, Nottingham ; Thomas J. G. Fleming, Esq., Limavady, co. Derry, Ireland ; Thomas Forster, Esq., Umaria Collicry, Umaria, India ; Edmund Johnstone Garwood, Esq., B.A., Villa Giuseppina, Cadenabbia, Lago di Como, Italy ; George Samuel Griffiths, Esq., 22 Collins Street West, Melbourne ; Dr. Frederick Henry Hatch, Ph.D., Aubry Lodge, Wellesley Road, Gunnersbury, W. ; Robert Tuthill Litton, Esq., Market Street, Melbourne ; Frederick William Martin, Esq., 37 Charlotte Road, Edgbaston, Birmingham ; Richard D. Oldham, Esq., A.R.S.M., Geological Survey of India, Calcutta ; Forbes Rickard, Esq., F.C.S., Ashcombe, Carlton Road, Putney, S.W. ; Albert Charles Seward, Esq., B.A., St. John's College, Cambridge ; Herbert William Vinter, Esq., M.A., Wesleyan College, Truro, Cornwall ; and Charles D. Walcott, Esq., U.S. Geological Survey, Washington, D.C., U.S. America, were elected Fellows of the Society.

The List of Donations to the Library was read.

The PRESIDENT announced that he had received from Prof. Ulrich, of Dunedin, N.Z., the announcement of a very interesting discovery which he had recently made. In the interior of the South Island of New Zealand there exists a range of mountains, composed of olivine-enstatite rocks, in places converted into serpentine. The sand of the rivers flowing from these rocks contains metallic particles which, on analysis, prove to be an alloy of nickel and iron in the

proportion of two atoms of the former metal to one of the latter. Similar particles have also been detected in the serpentines. This alloy, though new as a native terrestrial product, is identical with the substance of the Octibeha meteorite, which has been called octibehite. Prof. Ulrich has announced his intention of communicating to the Society a paper dealing with the details of this discovery—which is certainly one of the most interesting that has been made since the recognition of the terrestrial origin of the Ovifak irons.

The following communications were read:—

1. “On a new Genus of Madreporaria—*Glyphastræa*, with remarks on the Morphology of *Glyphastræa Forbesi*, Edw. & H., sp., from the Tertiaries of Maryland, U.S.” By Prof. P. Martin Duncan, M.B., F.R.S., F.G.S., &c.

2. “On the Metamorphic Rocks of the Malvern Hills.—Part 1.” By Frank Rutley, Esq., F.G.S., Lecturer on Mineralogy in the Royal School of Mines.

3. “On Fossil Chilostomatous Bryozoa from New Zealand.” By Arthur Wm. Waters, Esq., F.G.S.

The following specimens were exhibited:—

Specimens of Metamorphic Rocks from the Malvern Hills, exhibited by Frank Rutley, Esq., F.G.S., in illustration of his paper.

Fossil Corals, exhibited by Prof. P. M. Duncan, M.B., F.R.S., F.G.S., in illustration of his paper.

A specimen and section of Great Corndon Laccolite from Shropshire, showing junction of the erupted rock with the overlying Ladywell Schist, exhibited by C. J. Alford, Esq., F.G.S.

December 15, 1886.

Prof. J. W. Judd, F.R.S., President, in the Chair.

John Usher, Esq., Wentworth Court, Sydney, New South Wales, and Joseph Tertius Wood, Esq., Shaw House, Rochdale, were elected Fellows of the Society.

The List of Donations to the Library was read.

The following communications were read:—

1. “Notes on *Nummulites elegans*, Sow., and other English Nummulites.” By Prof. T. Rupert Jones, F.R.S., F.G.S.

2. "On the Dentition and Affinities of the Selachian Genus *Ptychodus*, Agassiz." By A. Smith Woodward, Esq., F.G.S.

3. "On a Molar of a Pliocene type of *Equus* from Nubia." By R. Lydekker, Esq., B.A., F.G.S.

The following specimens were exhibited:—

Specimens of Nummulites, exhibited by Prof. T. Rupert Jones, F.R.S., F.G.S., in illustration of his paper.

Specimens, exhibited by Henry Willett, Esq., F.G.S., and Dr. H. Woodward, F.R.S., F.G.S., in illustration of the paper by A. Smith Woodward, Esq., F.G.S.

Two molars of *Equus*, exhibited by R. Lydekker, Esq., F.G.S., in illustration of his paper.

January 12, 1887.

Prof. J. W. Judd, F.R.S., President, in the Chair.

Frederick Joseph Forfeitt, Esq., Medburn, near Elstree, Hertfordshire; James Lemon, Esq., M.Inst.C.E., Lansdowne House, Southampton, and Palace Chambers, Westminster; Charles Samuel Routh, Esq., 14 Southampton Street, Bloomsbury; and Thomas Davies Whittington, Esq., B.A., 6 Norlands, East Dulwich Road, S.E., were elected Fellows; Professor Josiah Dwight Whitney, of Cambridge, Mass., U.S.A., a Foreign Member, and Professor A. de Lapparent, of Paris, a Foreign Correspondent of the Society.

The List of Donations to the Library was read.

The PRESIDENT announced the sad loss which the Society had sustained since the last Meeting by the death of Mr. John Arthur Phillips, F.R.S., who had been for several years a valuable member of the Council, and one of the Vice-Presidents of the Society.

The following communications were read:—

1. "The Ardtun Leaf-beds." By J. Starkie Gardner, Esq., F.G.S., F.L.S.; with Notes by Grenville A. J. Cole, Esq., F.G.S.

2. "On the Echinoidea of the Cretaceous Strata of the Lower Nabadá Region." By Prof. P. Martin Duncan, M.B., F.R.S., F.G.S.

3. "On certain Dinosaurian Vertebræ from the Cretaceous of India and the Isle of Wight." By R. Lydekker, Esq., B.A., F.G.S.

4. "Further Notes on the Results of some deep Borings in Kent." By W. Whitaker, Esq., B.A., F.G.S.

The following specimens were exhibited :—

Plant-remains, rock-specimens, and microscopic sections, exhibited by J. S. Gardner, Esq., F.G.S., in illustration of his paper.

Echinoderms from the three Calcareous deposits of the Cretaceous formation, Bag Series, exhibited by Prof. P. M. Duncan, M.B., F.R.S., F.G.S., in illustration of his paper.

Specimens of cores, exhibited by W. Whitaker, Esq., B.A., F.G.S., in illustration of his paper.

January 26, 1887.

Prof. J. W. JUDD, F.R.S., President, in the Chair.

Abraham Farrar, Esq., Jun., The Grange, Beech Grove, Harrogate, and Frederick Schute, Esq., 3 West Mount, Scarborough, were elected Fellows of the Society.

The List of Donations to the Library was read.

The following communications were read :—

1. "On the Correlation of the Upper Jurassic Rocks of the Jura with those of England." By Thomas Roberts, Esq., M.A., F.G.S.

2. "The Physical History of the Bagshot Beds of the London Basin." By the Rev. A. Irving, B.Sc., B.A., F.G.S.

The following specimens were exhibited :—

Specimens from the Bagshot Beds, and of combination analyses, exhibited by the Rev. A. Irving, B.Sc., F.G.S., in illustration of his paper.

Photographs of a Glacial Pot-hole, at Archibald, Pa., U.S.A., exhibited by Archibald Geikie, LL.D., F.R.S., V.P.G.S.

February 9, 1887.

Prof. J. W. JUDD, F.R.S., President, in the Chair.

Samuel Farnfield, Esq., Eversley House, Guildford; Henry Hill, Esq., B.A., Napier, New Zealand; and John Morison, M.D., Victoria Street, St. Albans, were elected Fellows of the Society.

The List of Donations to the Library was read.

The following communications were read :—

1. "Evidence of Glacial Action in the Carboniferous and Hawkesbury Series, New South Wales." By T. W. Edgworth David, Esq., F.G.S.

2. "The Terraces of Rotomahana, New Zealand." By Josiah Martin, Esq., F.G.S.

3. "The Eruption of Mount Tarawera." By Capt. F. W. Hutton, F.G.S.

The following specimens were exhibited :—

Specimens of glacially polished blocks, from the Carboniferous glacial beds of New South Wales, and photographs of sections in those deposits, exhibited by T. W. Edgworth David, Esq., F.G.S., in illustration of his paper.

Faceted and striated boulders from the Olive Beds (Pretertiary) of the Salt Range, Punjab, India, exhibited by W. T. Blanford, LL.D., F.R.S., Sec.G.S.

Photographs of the Terraces of Rotomahana, exhibited by Josiah Martin, Esq., F.G.S., in illustration of his paper.

Photographs and specimens of Volcanic materials with microscopic sections, exhibited by Capt. F. W. Hutton, F.G.S., in illustration of his paper.

Maps, plans, and photographs with specimens of Volcanic dust, &c., illustrating the eruption of Tarawera, exhibited by James Hector, C.M.G., M.D., F.R.S., F.G.S.

Striated stone from the Upper Old Red Conglomerate, Pennine Escarpment near Melmerby, Cumberland, exhibited by J. G. Goodchild, Esq., F.G.S.

ANNUAL GENERAL MEETING,

February 19, 1887.

Prof. J. W. JUDD, F.R.S., President, in the Chair.

REPORT OF THE COUNCIL FOR 1886.

IN presenting their Report for the year 1886, the Council of the Geological Society have much pleasure in once more congratulating the Fellows upon the prosperous state of the Society, although they have not to announce any increase in the total number of Fellows. But the Income of the Society has been larger and the Expenditure less than in the year 1885, so that notwithstanding the Investment of a sum of £250, the Balance in the Society's favour shows a considerable increase.

The number of Fellows elected during the year is 41, of whom 30 paid their fees before the end of the year, making with 16 previously elected Fellows, who paid their fees in 1886, a total accession during the year of 46 Fellows. Against this we have to set the loss by death of 28 Fellows, and by resignation of 10 Fellows, while 10 Fellows were removed from the List for non-payment of their contributions, making a total loss of 48 Fellows. There is thus an actual decrease of 2 in the number of Fellows of the Society. Of the 28 Fellows deceased, 5 were Compounders, and 6 non-contributing Fellows; the number of contributing Fellows is increased by 2, being now 833.

The total number of Fellows, Foreign Members and Foreign Correspondents was 1425 at the end of the year 1885, and 1423 at the close of 1886.

At the end of 1885 there was one vacancy in the List of Foreign Members, and this was filled up in the course of 1886. During the year, intelligence was received of the decease of one Foreign Member. The List of Foreign Correspondents also showed one vacancy at the end of 1885, and intelligence was received in 1886 of the decease of another Foreign Correspondent. This loss, with the filling up of the vacancy among the Foreign Members, caused in all 3 vacancies in the List of Foreign Correspondents, two of which were filled up within the year. Thus at the close of the year 1886 there was one vacancy in the list of Foreign Members, and one in that of Foreign Correspondents.

The total Receipts on account of Income for the year 1886 were £2669, being £117 1s. 4*d.* more than the estimated Income for the year. The total Expenditure, on the other hand, was only £2278 14s. 3*d.*, or £229 1s. 9*d.* less than the estimated Expenditure for the year. The excess of the Income over the Expenditure of the year was £390 5s. 9*d.*

A sum of £250 12s. 6*d.* having been expended in the purchase of £250 reduced 3 per cent. stock, the balance at the disposal of the Society at 31st December last amounted to £576 19s. 1*d.* As the Council have every reason to believe that the expenditure of the present year will be well within the estimates, they think it may be advisable in the course of the coming summer to make use of a part of the above balance for the execution of necessary repairs, painting, &c., of the interior of the Society's House.

The Council have to announce the completion of Vol. XLII. of the Society's Quarterly Journal, and the commencement of Vol. XLIII.

In consequence of the sudden death of the late Clerk, Mr. W. W. Leighton, the Council were led to consider the organization of the paid Officers of the Society, and they decided formally to combine the office of Clerk with that of Assistant Secretary, giving him a second Assistant, whose duties should be primarily those of a Clerk in the Office, but with the proviso that he should assist in the work of the Library when required to do so. After a careful consideration of the testimonials of numerous applicants, the Council appointed Mr. F. E. Brown to the vacant post, and the appointment was duly confirmed by the Society at the Meeting of the 21st of April, 1886.

The Council have awarded the Wollaston Medal to J. Whitaker Hulke, Esq., F.R.S., F.G.S., in recognition of the importance to Geological Science of his researches into the structure and affinities of Fossil Reptilia, especially of the Dinosauria.

The Murchison Medal, with the sum of Ten Guineas from the Fund, has been awarded to the Rev. P. B. Brodie, M.A., F.G.S., as a mark of appreciation of his long-continued study of the Stratigraphy of Central England, and of his important contributions to the Science of Fossil Entomology.

The Lyell Medal, with the sum of Twenty-five Pounds from the proceeds of the Fund, has been awarded to Samuel Allport, Esq., F.G.S., in recognition of the admirable work done by him as one of the pioneers of the science of Microscopic Petrology.

The Bigsby Medal has been awarded to Prof. Charles Lapworth, LL.D., F.G.S., as a testimony to the value of his palæontological and stratigraphical researches, and particularly of the additions made by him to our knowledge of the structure and distribution of Graptolites, and of his investigation of the Lower Palæozoic and Archæan Rocks of Scotland.

The balance of the proceeds of the Wollaston Donation Fund has been awarded to B. N. Peach, Esq., F.G.S., in token of appreciation of his important contributions to the Palæontology and Geology of Scotland, and to aid him in future investigations.

The balance of the proceeds of the Murchison Geological Fund has been awarded to Robert Kidston, Esq., F.G.S., in recognition of the value of his studies in Fossil Botany, and to aid him in further prosecuting his researches into the structure and affinities of the plants found in the Carboniferous Rocks.

The balance of the proceeds of the Lyell Geological Fund has been awarded to the Rev. Osmond Fisher, Esq., M.A., F.G.S., in testimony of appreciation of his contributions to the Physical History of the Earth, and to various branches of Physical Geology, and to assist him in continuing his studies of these and similar subjects.

REPORT OF THE LIBRARY AND MUSEUM COMMITTEE.

Library.

Since the last Anniversary Meeting a great number of valuable additions have been made to the Library, both by donation and by purchase.

As Donations the Library has received about 157 volumes of separately published works and Survey Reports, and about 321 separate impressions of Memoirs and other Pamphlets, besides about 153 volumes and 78 detached parts of the publications of various Societies. Besides these about 11 volumes of independent Periodicals, presented chiefly by their respective Editors, and 11 volumes of Newspapers of various kinds have been received. This will constitute a total addition to the Society's Library, by donation, of about 350 volumes and 321 pamphlets.

A considerable number of Maps, Plans, and Charts have been added to the Society's collections by presentation, chiefly, as in former years, from the Ordnance Survey of Great Britain, whose donations amount to 457 sheets, large and small. From the French Dépôt de la Marine, 39 sheets have been received. The remainder, consisting of 39 sheets, includes 6 sheets from the Geological Survey of Saxony, 3 from that of Belgium, 6 from the Roumanian Geological Survey, and 2 from the Geological Survey of Norway, besides 12 sheets of Maps and Plans of Krakatau presented by the Netherlands Government, a Geological Map of Zillah Behar, presented by Prof. W. T. Thiselton Dyer, 2 copies (one coloured, one in black and white) of a geological map of the mountain region of British Honduras, prepared and presented by C. H. Wilson, Esq., F.G.S., 6 sheets of a geological map of Russian Turkestan by M. J. Mouschetoff, and a geological map of the United States of North America, by C. H. Hitchcock, Esq.

The total number of Maps, Plans, and Charts presented during the year was 535.

The books and maps above referred to have been received from 158 personal Donors, the Editors or Publishers of 13 Periodicals, and 177 Societies, Surveys, and other Public Bodies, making in all 348 Donors.

By Purchase, on the recommendation of the Standing Library Committee, the Library has received the addition of 49 volumes of Books, and of 61 parts (making about 20 volumes) of various Periodicals, besides 33 parts of certain works published serially. Of the Geological Survey Map of France, 7 sheets have been obtained by purchase, besides 12 sheets of the smaller Geological Map of France and the neighbouring districts, by MM. Vasseur and Carez.

The cost of Books, Periodicals, and Maps purchased during the year 1886 was £44 17s 10d., and of Binding £66 13s. 4d., making a total of £111 11s. 2d.

With the view of rendering the Library more useful to the Fellows, it is now kept open on the days of the Society's Meetings from 5 to 8 o'clock in the evening.

Museum.

The Collections in the Museum remain in much the same condition as at the date of the last Report of the Committee.

The additions during the year 1886 have not been numerous; they consist of a collection of specimens presented by M. F. Cornet, illustrating his paper on the Phosphatic Beds in the neighbourhood of Mons; of a collection of rock-specimens from Assouan, presented by Sir J. W. Dawson and Prof. Bonney; and of 2 elytra of Beetles from London Clay of Peckham, a specimen of *Palæocorystes glabra*, and one of *Litoricola glabra* from the Lower Eocene of Portsmouth, bequeathed to the Society by the late Caleb Evans, Esq., F.G.S.

COMPARATIVE STATEMENT OF THE NUMBER OF THE SOCIETY AT THE
CLOSE OF THE YEARS 1885 AND 1886.

	Dec 31, 1885.		Dec. 31, 1886.
Compounders	312	314
Contributing Fellows	831	833
Non-contributing Fellows ..	204	198
	<hr/>		<hr/>
	1347		1345
Foreign Members	39	39
Foreign Correspondents	39	39
	<hr/>		<hr/>
	1425		1423

Comparative Statement explanatory of the Alterations in the Number of Fellows, Foreign Members, and Foreign Correspondents at the close of the years 1885 and 1886.

Number of Compounders, Contributing and Non-contributing Fellows, December 31, 1885	}	1347
<i>Add</i> Fellows elected during former year and paid in 1886	}	16
<i>Add</i> Fellows elected and paid in 1886	}	30
		<hr/>
		1393
<i>Deduct</i> Compounders deceased	5	
Contributing Fellows deceased	17	
Non-contributing Fellows deceased	6	
Contributing Fellows resigned	10	
Contributing Fellows removed	10	
	<hr/>	48
		<hr/>
		1345
Number of Foreign Members, and Foreign Correspondents, December 31, 1885	}	78
<i>Deduct</i> Foreign Member deceased	1	
Foreign Correspondent deceased	1	
Foreign Correspondent elected	1	
Foreign Member	}	1
	<hr/>	3
		<hr/>
		75
<i>Add</i> Foreign Member elected	1	
Foreign Correspondents elected	2	
	<hr/>	78
		<hr/>
		1423
		<hr/> <hr/>

DECEASED FELLOWS.

Compounders (5).

Auldjo, J., Esq.
 Cardwell, Viscount.
 Morris, Prof. J.

Romilly, Hon. E.
 Storey, E., Esq.

Resident and other Contributing Fellows (17).

Blount, W., Esq.
 Bunbury, Sir C. J. F.
 Busk, Prof. G.
 Cumming, J., Esq.
 Dawson, J., Esq.
 Downes, Rev. W.
 Evans, C., Esq.
 Enniskillen, Earl of.
 Fergusson, Dr. J.

Grote, A., Esq.
 Guthrie, Prof. F.
 Holl, Dr. H. B.
 Milnes, W., Esq.
 Seyton, C. S., Esq.
 Smith, T. M., Esq.
 Steele, Dr. J. D.
 Whitehead, F. T., Esq.

Non-contributing Fellows (6).

Adams, W., Esq.
 Carey, Sir P.
 Ellis, F. J., Esq.

Harding, Lieut.-Col. W.
 Laurance, J., Esq.
 Richardson, J., Esq.

Foreign Member (1).

Abich, Dr. H.

Foreign Correspondent (1).

Guiscardi, Professor G.

Fellows Resigned (10).

Green, W. A., Esq.
 Hastings, Rev. F.
 Johnson, J., Esq.
 Kimball, Dr. J. P.
 Musson, E. C., Esq.

Provis, E., Esq.
 Ramsay, A., Esq.
 Randell, J. S., Esq.
 Tarbotton, M. O., Esq.
 Thornburn, J., Esq.

Fellows Removed (10).

Duigan, J., Esq.	Parton, T., Esq.
Fisher, H., Esq.	Rogers, Dr. G.
Forster, R. C., Esq.	Shakespear, Lieut.-Col. J. D.
Mason, J. W., Esq.	Simpson-Baikie, E., Esq.
Méchin, Rev. E.	Woodhouse, Rev. T. E.

The following Personage was elected from the List of Foreign Correspondents to fill a vacancy in the List of Foreign Members during the year 1886.

Professor Gustav Tschermak of Vienna.

The following Personages were elected Foreign Correspondents during the year 1886.

Professor J. Vilanova-y-Piera of Madrid.
Professor H. Rosenbusch of Heidelberg.

After the Reports had been read, it was resolved :—

That they be received and entered on the Minutes of the Meeting, and that such parts of them as the Council shall think fit be printed and distributed among the Fellows.

It was afterwards resolved :—

That the thanks of the Society be given to Dr. John Evans retiring from the office of Vice-President.

That the thanks of the Society be given to Dr. John Evans, Dr. G. J. Hinde, John Hopkinson, Esq., and W. Topley, Esq., retiring from the Council.

After the Balloting-glasses had been duly closed, and the Lists examined by the Scrutineers, the following gentlemen were declared to have been duly elected as the Officers and Council for the ensuing year :—

OFFICERS.

PRESIDENT.

Prof. J. W. Judd, F.R.S.

VICE-PRESIDENTS.

H. Bauerman, Esq.
 Prof. T. G. Bonney, D.Sc., F.R.S.
 A. Geikie, LL.D., F.R.S.
 Henry Woodward, LL.D., F.R.S.

SECRETARIES.

W. T. Blanford, LL.D., F.R.S.
 W. H. Hudleston, Esq., M.A., F.R.S.

FOREIGN SECRETARY.

Warrington W. Smyth, Esq., M.A., F.R.S.

TREASURER.

Prof. T. Wiltshire, M.A., F.L.S.

COUNCIL.

H. Bauerman, Esq.	Prof. T. Rupert Jones, F.R.S.
W. T. Blanford, LL.D., F.R.S.	Prof. J. W. Judd, F.R.S.
Prof. T. G. Bonney, D.Sc., LL.D., F.R.S.	R. Lydekker, Esq., B.A.
A. Champernowne, Esq., M.A.	J. E. Marr, Esq., M.A.
Thomas Davies, Esq.	E. Tulley Newton, Esq.
Prof. P. M. Duncan, M.B., F.R.S.	Prof. H. G. Seeley, F.R.S.
A. Geikie, LL.D., F.R.S.	Warrington W. Smyth, Esq., M.A., F.R.S.
Henry Hicks, M.D., F.R.S.	J. J. H. Teall, Esq., M.A.
Rev. Edwin Hill, M.A.	Prof. T. Wiltshire, M.A., F.L.S.
W. H. Hudleston, Esq., M.A., F.R.S.	Rev. H. H. Winwood, M.A.
Prof. T. McKenny Hughes.	Henry Woodward, LL.D., F.R.S.
J. W. Hulke, Esq., F.R.S.	

LIST OF
THE FOREIGN MEMBERS

OF THE GEOLOGICAL SOCIETY OF LONDON, IN 1886.

Date of
Election.

1827. Dr. H. von Dechen, *Bonn*.
1848. James Hall, Esq., *Albany, State of New York*.
1850. Professor Bernhard Studer, *Berne*.
1851. Professor James D. Dana, *New Haven, Connecticut*.
1851. General G. von Helmersen, *St. Petersburg*. (*Deceased.*)
1853. Count Alexander von Keyserling, *Raykiüll, Russia*.
1853. Professor L. G. de Koninck, *Liège*.
1856. Professor Robert Bunsen, For. Mem. R.S., *Heidelberg*.
1857. Professor H. B. Geinitz, *Dresden*.
1859. Dr. Ferdinand Römer, *Breslau*.
1860. Dr. H. Milne-Edwards, For. Mem. R.S., *Paris*. (*Deceased.*)
1864. M. Jules Desnoyers, *Paris*.
1866. Dr. Joseph Leidy, *Philadelphia*.
1867. Professor A. Daubrée, For. Mem. R.S., *Paris*.
1871. Dr. Franz Ritter von Hauer, *Vienna*.
1874. Professor Alphonse Favre, *Geneva*.
1874. Professor E. Hébert, *Paris*.
1874. Professor Albert Gaudry, *Paris*.
1875. Professor Fridolin Sandberger, *Würzburg*.
1875. Professor Theodor Kjerulf, *Christiania*.
1875. Professor F. August Quenstedt, *Tübingen*.
1876. Professor E. Beyrich, *Berlin*.
1877. Dr. Carl Wilhelm Gumbel, *Munich*.
1877. Dr. Eduard Suess, *Vienna*.
1879. Dr. F. V. Hayden, *Washington*.
1879. Major-General N. von Kokscharow, *St. Petersburg*.
1879. M. Jules Marcou, *Cambridge, U. S.*
1879. Dr. J. J. S. Steenstrup, For. Mem. R.S., *Copenhagen*.
1880. Professor Gustave Dewalque, *Liège*.
1880. Baron Adolf Erik Nordenskiöld, *Stockholm*.
1880. Professor Ferdinand Zirkel, *Leipzig*.
1882. Professor Sven Lovén, *Stockholm*.
1882. Professor Ludwig Rüttimeyer, *Basle*.
1883. Professor J. S. Newberry, *New York*.
1883. Professor Otto Martin Torell, *Stockholm*.
1884. Professor G. Capellini, *Bologna*.
1884. Professor A. L. O. Des Cloizeaux, For. Mem. R.S., *Paris*.
1884. Professor G. Meneghini, *Pisa*.
1884. Professor J. Szabó, *Pesth*.
1885. Professor Jules Gosselet, *Lille*.
1886. Professor Gustav Tschermak, *Vienna*.

LIST OF
THE FOREIGN CORRESPONDENTS

OF THE GEOLOGICAL SOCIETY OF LONDON, IN 1886.

Date of
Election.

1863. Count A. G. Marschall, *Vienna*.
 1863. Professor Giuseppe Ponzi, *Rome*. (*Deceased.*)
 1863. Dr. F. Senft, *Eisenach*.
 1864. Dr. Charles Martins, *Montpellier*.
 1866. Professor J. P. Lesley, *Philadelphia*.
 1866. Professor Victor Raulin, *Bordeaux*.
 1866. Baron Achille de Zigno, *Padua*.
 1872. Herr Dionys Stur, *Vienna*.
 1872. Professor J. D. Whitney, *Cambridge, U. S.*
 1874. Professor Iginò Cocchi, *Florence*.
 1874. M. Gustave H. Cotteau, *Auxerre*.
 1874. Professor G. Seguenza, *Messina*.
 1874. Dr. T. C. Winkler, *Haarlem*.
 1877. Professor George J. Brush, *New Haven*.
 1877. Professor E. Renevier, *Lausanne*.
 1877. Count Gaston de Saporta, *Aix-en-Provence*.
 1879. Professor Pierre J. van Beneden, For. Mem. R.S., *Louvain*.
 1879. M. Édouard Dupont, *Brussels*.
 1879. Professor Gerhard Vom Rath, *Bonn*.
 1879. Dr. Émile Sauvage, *Paris*.
 1880. Professor Luigi Bellardi, *Turin*.
 1880. Professor Leo Lesquereux, *Columbus*.
 1880. Dr. Melchior Neumayr, *Vienna*.
 1880. M. Alphonse Renard, *Brussels*.
 1881. Professor E. D. Cope, *Philadelphia*.
 1882. Professor Louis Lartet, *Toulouse*.
 1882. Professor Alphonse Milne-Edwards, *Paris*.
 1883. M. François Leopold Cornet, *Mons*.
 1883. Baron Ferdinand von Richthofen, *Leipzig*.
 1883. Professor Karl Alfred Zittel, *Munich*.
 1884. Dr. Charles Barrois, *Lille*.
 1884. M. Alphonse Briart, *Morlanwelz*.
 1884. Professor Hermann Credner, *Leipzig*.
 1884. Baron C. von Ettingshausen, *Gratz*.
 1884. Dr. E. Mojsisovics von Mojsvár, *Vienna*.
 1885. M. F. Fouqué, *Paris*.
 1885. Professor G. Lindström, *Stockholm*.
 1885. Dr. A. G. Nathorst, *Stockholm*.
 1886. Professor H. Rosenbusch, *Heidelberg*.
 1886. Professor J. Vilanova y Piera, *Madrid*.

AWARDS OF THE WOLLASTON MEDAL

UNDER THE CONDITIONS OF THE "DONATION FUND"

ESTABLISHED BY

WILLIAM HYDE WOLLASTON, M.D., F.R.S., F.G.S., &c.

"To promote researches concerning the mineral structure of the earth, and to enable the Council of the Geological Society to reward those individuals of any country by whom such researches may hereafter be made,"—"such individual not being a Member of the Council."

- | | |
|-------------------------------------|-----------------------------------|
| 1831. Mr. William Smith. | 1860. Mr. Searles V. Wood. |
| 1835. Dr. G. A. Mantell. | 1861. Professor Dr. H. G. Bronn. |
| 1836. M. Louis Agassiz. | 1862. Mr. R. A. C. Godwin-Austen. |
| 1837. } Capt. T. P. Cautley. | 1863. Professor Gustav Bischof. |
| } Dr. H. Falconer. | 1864. Sir R. I. Murchison. |
| 1838. Sir Richard Owen. | 1865. Dr. Thomas Davidson. |
| 1839. Professor C. G. Ehrenberg. | 1866. Sir Charles Lyell. |
| 1840. Professor A. H. Dumont. | 1867. Mr. G. Poulett Scrope. |
| 1841. M. Adolphe T. Brongniart. | 1868. Professor Carl F. Naumann |
| 1842. Baron L. von Buch. | 1869. Dr. H. C. Sorby. |
| 1843. } M. Elie de Beaumont. | 1870. Professor G. P. Deshayes. |
| } M. P. A. Dufrenoy. | 1871. Sir A. C. Ramsay. |
| 1844. Rev. W. D. Conybeare. | 1872. Professor J. D. Dana. |
| 1845. Professor John Phillips. | 1873. Sir P. de M. Grey-Egerton. |
| 1846. Mr. William Lonsdale. | 1874. Professor Oswald Heer. |
| 1847. Dr. Ami Boué. | 1875. Professor L. G. de Koninck. |
| 1848. Rev. Dr. W. Buckland. | 1876. Professor T. H. Huxley. |
| 1849. Professor Joseph Prestwich. | 1877. Mr. Robert Mallet. |
| 1850. Mr. William Hopkins. | 1878. Dr. Thomas Wright. |
| 1851. Rev. Prof. A. Sedgwick. | 1879. Professor Bernhard Studer. |
| 1852. Dr. W. H. Fitton. | 1880. Professor Auguste Daubrée. |
| 1853. } M. le Vicomte A. d'Archiac. | 1881. Professor P. Martin Duncan. |
| } M. E. de Verneuil. | 1882. Dr. Franz Ritter von Hauer. |
| 1854. Sir Richard Griffith. | 1883. Dr. W. T. Blanford. |
| 1855. Sir H. T. De la Beche. | 1884. Professor Albert Gaudry. |
| 1856. Sir W. E. Logan. | 1885. Mr. George Busk. |
| 1857. M. Joachim Barrande. | 1886. Professor A. L. O. Des |
| 1858. } Herr Hermann von Meyer. | Cloizeaux. |
| } Mr. James Hall. | 1887. Mr. J. W. Hulke. |
| 1859. Mr. Charles Darwin. | |

A W A R D S

OF THE

BALANCE OF THE PROCEEDS OF THE WOLLASTON
"DONATION-FUND."

- | | |
|------------------------------------|------------------------------------|
| 1831. Mr. William Smith. | 1861. Professor A. Daubrée. |
| 1833. Mr. William Lonsdale. | 1862. Professor Oswald Heer. |
| 1834. M. Louis Agassiz. | 1863. Professor Ferdinand Senft. |
| 1835. Dr. G. A. Mantell. | 1864. Professor G. P. Deshayes. |
| 1836. Professor G. P. Deshayes. | 1865. Mr. J. W. Salter. |
| 1838. Sir Richard Owen. | 1866. Dr. Henry Woodward. |
| 1839. Professor C. G. Ehrenberg. | 1867. Mr. W. H. Baily. |
| 1840. Mr. J. De Carle Sowerby. | 1868. M. J. Bosquet. |
| 1841. Professor Edward Forbes. | 1869. Mr. W. Carruthers. |
| 1842. Professor John Morris. | 1870. M. Marie Rouault. |
| 1843. Professor John Morris. | 1871. Mr. R. Etheridge. |
| 1844. Mr. William Lonsdale. | 1872. Dr. James Croll. |
| 1845. Mr. Geddes Bain. | 1873. Professor J. W. Judd. |
| 1846. Mr. William Lonsdale. | 1874. Dr. Henri Nyst. |
| 1847. M. Alcide d'Orbigny. | 1875. Mr. L. C. Miall. |
| 1848. { Cape-of-Good-Hope Fossils. | 1876. Professor Giuseppe Seguenza. |
| { M. Alcide d'Orbigny. | 1877. Mr. R. Etheridge, Jun. |
| 1849. Mr. William Lonsdale. | 1878. Professor W. J. Sollas. |
| 1850. Professor John Morris. | 1879. Mr. S. Allport. |
| 1851. M. Joachim Barrande. | 1880. Mr. Thomas Davies. |
| 1852. Professor John Morris. | 1881. Dr. R. H. Traquair. |
| 1853. Professor L. G. de Koninck. | 1882. Dr. G. J. Hinde. |
| 1854. Dr. S. P. Woodward. | 1883. Mr. John Milne. |
| 1855. Drs. G. and F. Sandberger. | 1884. Mr. E. Tulley Newton. |
| 1856. Professor G. P. Deshayes. | 1885. Dr. Charles Callaway. |
| 1857. Dr. S. P. Woodward. | 1886. Mr. J. S. Gardner. |
| 1858. Mr. James Hall. | 1887. Mr. B. N. Peach. |
| 1859. Mr. Charles Peach. | |
| 1860. { Professor T. Rupert Jones. | |
| { Mr. W. K. Parker. | |
-

AWARDS OF THE MURCHISON MEDAL

AND OF THE

PROCEEDS OF "THE MURCHISON GEOLOGICAL FUND,"

ESTABLISHED UNDER THE WILL OF THE LATE

SIR RODERICK IMPEY MURCHISON, BART., F.R.S., F.G.S.

"To be applied in every consecutive year in such manner as the Council of the Society may deem most useful in advancing geological science, whether by granting sums of money to travellers in pursuit of knowledge, to authors of memoirs, or to persons actually employed in any inquiries bearing upon the science of geology, or in rewarding any such travellers, authors, or other persons, and the Medal to be given to some person to whom such Council shall grant any sum of money or recompense in respect of geological science."

- | | |
|--|--|
| 1873. Mr. William Davies. <i>Medal.</i> | 1881. Professor A. Geikie. <i>Medal.</i> |
| 1873. Professor Oswald Heer. | 1881. Mr. F. Rutley. |
| 1874. Dr. J. J. Bigsby. <i>Medal.</i> | 1882. Professor J. Gosselet. <i>Medal.</i> |
| 1874. Mr. Alfred Bell. | 1882. Professor T. Rupert Jones. |
| 1874. Professor Ralph Tate. | 1883. Professor H. R. Göppert. |
| 1875. Mr. W. J. Henwood. <i>Medal.</i> | <i>Medal.</i> |
| 1875. Professor H. G. Seeley. | 1883. Mr. John Young. |
| 1876. Mr. A. R. C. Selwyn. <i>Medal.</i> | 1884. Dr. H. Woodward. <i>Medal.</i> |
| 1876. Dr. James Croll. | 1884. Mr. Martin Simpson. |
| 1877. Rev. W. B. Clarke. <i>Medal.</i> | 1885. Dr. Ferdinand Römer. |
| 1877. Professor J. F. Blake. | <i>Medal.</i> |
| 1878. Dr. H. B. Geinitz. <i>Medal.</i> | 1885. Mr. Horace B. Woodward. |
| 1878. Professor C. Lapworth. | 1886. Mr. W. Whitaker. <i>Medal.</i> |
| 1879. Professor F. McCoy. <i>Medal.</i> | 1886. Mr. Clement Reid. |
| 1879. Mr. J. W. Kirkby. | 1887. Rev. P. B. Brodie. <i>Medal.</i> |
| 1880. Mr. R. Etheridge. <i>Medal.</i> | 1887. Mr. Robert Kidston. |
-

AWARDS OF THE LYELL MEDAL

AND OF THE

PROCEEDS OF THE "LYELL GEOLOGICAL FUND,"

ESTABLISHED UNDER THE WILL AND CODICIL OF THE LATE
SIR CHARLES LYELL, BART., F.R.S., F.G.S.

The Medal "to be given annually" (or from time to time) "as a mark of honorary distinction as an expression on the part of the governing body of the Society that the Medallist has deserved well of the Science,"—"not less than one third of the annual interest [of the fund] to accompany the Medal, the remaining interest to be given in one or more portions at the discretion of the Council for the encouragement of Geology or of any of the allied sciences by which they shall consider Geology to have been most materially advanced."

- | | |
|---|--|
| 1876. Professor John Morris.
<i>Medal.</i> | 1882. Dr. J. Lycett. <i>Medal.</i> |
| 1877. Dr. James Hector. <i>Medal.</i> | 1882. Rev. Norman Glass. |
| 1877. Mr. W. Pengelly. | 1882. Professor C. Lapworth. |
| 1878. Mr. G. Busk. <i>Medal.</i> | 1883. Dr. W. B. Carpenter. <i>Medal.</i> |
| 1878. Dr. W. Waagen. | 1883. Mr. P. H. Carpenter. |
| 1879. Professor Edmond Hébert.
<i>Medal.</i> | 1883. M. E. Rigaux. |
| 1879. Professor H. A. Nicholson. | 1884. Dr. Joseph Leidy. <i>Medal.</i> |
| 1879. Dr. Henry Woodward. | 1884. Professor Charles Lapworth. |
| 1880. Mr. John Evans. <i>Medal.</i> | 1885. Professor H. G. Seeley.
<i>Medal.</i> |
| 1880. Professor F. Quenstedt. | 1885. Mr. A. J. Jukes-Browne. |
| 1881. Sir J. W. Dawson. <i>Medal.</i> | 1886. Mr. W. Pengelly. <i>Medal.</i> |
| 1881. Dr. Anton Fritsch. | 1886. Mr. D. Mackintosh. |
| 1881. Mr. G. R. Vine. | 1887. Mr. S. Allport. <i>Medal.</i> |
| | 1887. Rev. Osmond Fisher. |
-

AWARDS OF THE BIGSBY MEDAL,

FOUNDED BY

DR. J. J. BIGSBY, F.R.S., F.G.S.

To be awarded biennially "as an acknowledgment of eminent services in any department of Geology, irrespective of the receiver's country; but he must not be older than 45 years at his last birthday, thus probably not too old for further work, and not too young to have done much."

1877. Professor O. C. Marsh.		1883. Dr. Henry Hicks.
1879. Professor E. D. Cope.		1885. Professor Alphonse Renard.
1881. Dr. C. Barrois.		1887. Professor Charles Lapworth.

AWARDS OF THE PROCEEDS OF THE BARLOW- JAMESON FUND,

ESTABLISHED UNDER THE WILL OF THE LATE

DR. H. C. BARLOW, F.G.S.

"The perpetual interest to be applied every two or three years, as may be approved by the Council, to or for the advancement of Geological Science."

1880. Purchase of microscope.		1884. Dr. James Croll.
1881. Purchase of microscope lamps.		1884. Professor Leo Lesquereux.
1882. Baron C. von Ettingshausen.		1886. Dr. H. J. Johnston-Lavis.

ESTIMATES *for*

INCOME EXPECTED.

	£	s.	d.	£	s.	d.
Due for Arrears of Annual Contributions	140	0	0			
Due for Arrears of Admission-fees	50	0	0			
	<hr/>			190	0	0
Estimated Ordinary Income for 1887 :—						
Annual Contributions from Resident Fellows, and Non-residents, 1859 to 1861	1490	0	0			
Admission-fees	189	0	0			
Compositions	168	0	0			
Annual Contributions in advance	21	0	0			
Dividends on Consols and Reduced 3 per Cents.	237	0	0			
Sale of Transactions, Library-catalogue, Ormerod's Index, Hochstetter's New Zealand, and List of Fellows	5	0	0			
Sale of Quarterly Journal, including Longman's account	190	0	0			
Sale of Geological Map, including Stanford's account	7	0	0			
	<hr/>			202	0	0

£2497 0 0

THOMAS WILTSHIRE, TREAS.

3 Feb. 1887.

the Year 1887.

EXPENDITURE ESTIMATED.

	£	s.	d.	£	s.	d.
House Expenditure:						
Taxes and Insurance	43	10	0			
Gas.....	22	0	0			
Fuel	30	0	0			
Furniture and Repairs.....	15	0	0			
House-repairs and Maintenance.....	15	0	0			
Annual Cleaning	20	0				
Washing and Sundries.....	33	0	0			
Tea at Meetings	16	0	0			
	<hr/>			194	10	0
Salaries and Wages:						
Assistant Secretary	350	0	0			
Assistants in Library, Office, and Museum ...	220	0	0			
House Steward.....	105	0				
Housemaid	40	0	0			
Errand Boy	46	16	0			
Charwoman and Occasional Assistance.....	30	0	0			
Attendants at Meetings	8	0	0			
Accountant	10	10	0			
	<hr/>			810	6	0
Official Expenditure:						
Stationery	25	0	0			
Miscellaneous Printing	22	0	0			
Postages and other Expenses	65	0	0			
	<hr/>			112	0	0
Library				150	0	0
Publications:						
Quarterly Journal	950	0	0			
, ,, Commission, Postage, and Addressing	90	0	0			
List of Fellows	33	0	0			
Abstracts, including Postage	110	0	0			
	<hr/>			1183	0	0
Balance in favour of the Society				47	4	0
	<hr/>			£2497	0	0
	<hr/>					

Income and Expenditure during the

RECEIPTS.

	£	s.	d.	£	s.	d.
Balance in Bankers' hands, 1 January 1886.	423	1	6			
Balance in Clerk's hands, 1 January 1886.	14	4	4			
	<hr/>			437	5	10
Compositions				210	0	0
Arrears of Admission-fees	100	16	0			
Admission-fees, 1886	189	0	0			
	<hr/>			289	16	0
Arrears of Annual Contributions				145	16	0
Annual Contributions for 1886, viz.:						
Resident Fellows	1508	6	6			
Non-Resident Fellows ...	15	15	0			
	<hr/>			1524	1	6
Annual Contributions in advance				48	6	0
Dividends on Consols	202	19	8			
,, Reduced 3 per Cents.	33	13	6			
	<hr/>			236	13	2
Taylor & Francis: Advertisements in Journal, Vol. 41..				4	4	6
Publications:						
Sale of Journal, Vols. 1-41	105	7	8			
,, Vol. 42*	82	5	9			
Sale of Library Catalogue	2	1	0			
Sale of Geological Map	15	18	11			
Sale of Ormerod's Index.....	2	18	8			
Sale of Hochstetter's New Zealand	0	12	0			
Sale of List of Fellows	0	2	6			
	<hr/>			209	6	6
Journal Subscriptions in Advance.....				0	16	4
*Due from Messrs. Longman, in addition to the above, on Journal, Vol. 41, &c.....	64	11	11			
Due from Stanford on account of Geological Map	1	0	0			
	<hr/>			65	11	11
	<hr/>					

£3106 5 10

We have compared this statement with the Books and Accounts presented to us, and find them to agree.

(Signed) L. FLETCHER,
JOHN HOPKINSON. } *Auditors.*

4 February, 1887.

Year ending 31 December, 1886.

EXPENDITURE.

	£	s.	d.	£	s.	d.
House Expenditure:						
Taxes	29	5	0			
Fire-insurance	14	5	0			
Gas	27	15	9			
Fuel.....	28	4	6			
Furniture and Repairs	15	12	11			
House-repairs.....	29	9	5			
Annual Cleaning	19	10	0			
Washing and Sundries	31	8	5			
Tea at Meetings.....	15	0	0			
				210	11	0
Salaries and Wages :						
Assistant Secretary	350	0	0			
Clerk, Representatives of late	18	0	0			
Assistants in Library, Office, and Museum...	190	0	0			
House Steward	105	0	0			
Housemaid	40	0	0			
Errand Boy	46	0	6			
Charwoman	23	8	6			
Attendants at Meetings.....	7	15	0			
Accountant's Fee	10	10	0			
				790	14	0
Official Expenditure :						
Stationery	22	9	4			
Miscellaneous Printing.....	26	4	0			
Postages and other Expenses	101	15	5			
				150	8	9
Library				111	11	2
Publications :						
Geological Map	14	9	2			
Journal, Vols. 1-41.....	12	12	9			
,, Vol. 42	755	14	1			
,, " Commission, Postage, and Addressing .	89	5	10			
				844	19	11
List of Fellows.....	33	12	6			
Abstracts, including Postage	109	15	0			
				1015	9	4
Investment of £250 Reduced 3 per Cents. at 100 $\frac{1}{8}$				250	12	6
Balance in Bankers' hands, 31 Dec. 1886..	563	16	10			
Balance in Clerk's hands, 31 Dec. 1886 ..	13	2	3			
				576	19	1
				£3106	5	10

“WOLLASTON DONATION FUND.” TRUST ACCOUNT.

RECEIPTS.		PAYMENTS.	
	£ s. d.		£ s.
Balance at Bankers', 1 January, 1886	31 10 2	Cost of striking Gold Medal awarded to Prof. A. L. O. Des Cloizeaux	10 10 0
Dividends on the Fund invested in Reduced 3 per Cents.	31 8 10	Award to Mr. J. S. Gardner	21 0 2
		Balance at Bankers', 31 December, 1886	31 8 10
	<u>£62 19 0</u>		<u>£62 19 0</u>

“MURCHISON GEOLOGICAL FUND.” TRUST ACCOUNT.

RECEIPTS.		PAYMENTS.	
	£ s. d.		£ s. d.
Balance at Bankers', 1 January, 1886	19 8 4	Award to Mr. W. Whitaker, with Medal	10 10 0
Dividends on the Fund invested in London and North-Western Railway 4 per cent. Debenture Stock	38 13 4	” Mr. Clement Reid	27 8 0
		Cost of Medal	0 17 0
	<u>£58 1 8</u>	Balance at Bankers', 31 December, 1886	19 6 8
			<u>£58 1 8</u>

“LYELL GEOLOGICAL FUND.” TRUST ACCOUNT.

RECEIPTS.		PAYMENTS.	
	£ s. d.		£ s. d.
Balance at Bankers', 1 January, 1886	51 1 8	Award to Mr. W. Pengelly, with Medal	21 0 0
Dividends on the Fund invested in Metropolitan 3½ per cent. Stock	68 0 4	” Mr. D. Mackintosh	39 10 9
		Cost of Medal	1 1 0
	<u>£119 2 0</u>	New Reverse Die (Wyon)	6 10 0
		Balance at Bankers', 31 December, 1886	51 0 3
			<u>£119 2 0</u>

“BARLOW-JAMESON FUND.” TRUST ACCOUNT.

RECEIPTS.		PAYMENTS.	
	£ s. d.		£ s. d.
Balance at Bankers', 1 January, 1886	26 6 7	Award to Dr. H. J. Johnston-Lavis	21 0 0
Dividends on the Fund invested in Consols	14 10 0	Balance at Bankers', 31 December, 1886	19 16 7
	<u>£40 16 7</u>		<u>£40 16 7</u>

“BIGSBY FUND.” TRUST ACCOUNT.

RECEIPTS.	£	s.	d.	PAYMENTS.	£	s.	d.
Balance at Bankers', 1 January, 1886	6	1	8	Balance at Bankers', 31 December, 1886	12	3	0
Dividends on the Fund invested in New 3 per Cents.....	6	1	4		£12	3	0
	£12	3	0				

VALUATION OF THE SOCIETY'S PROPERTY; 31 December, 1886.

PROPERTY.	£	s.	d.	DEBTS.	£	s.	d.
Due from Longman & Co., on account of Journal, vol. xli. &c.	64	11	11	Balance in favour of the Society.....	9119	0	1
Due from Stanford on account of Map	1	0	0				
Due from Subscribers to Journal.....	0	16	4				
Balance in Bankers' hands, 31 Dec. 1886	563	16	10				
Balance in Clerk's hands, 31 Dec. 1886	13	2	3				
Funded Property:—							
Consols, at 100	6999	7	4				
Reduced 3 per Cents. at 100.....	1286	5	5				
Arrears of Admission-fee (considered good).....	50	0	0				
Arrears of Annual Contributions (considered good)....	140	0	0				
	£9119	0	1		£9119	0	1

[N.B.—The above does not include the value of the Collections, Library, Furniture, and stock of unsold Publications.]

THOMAS WILTSHIRE, Treas.

3 Feb. 1887.

AWARD OF THE WOLLASTON MEDAL.

In presenting the Wollaston Gold Medal to Mr. J. W. HULKE, F.R.S., the PRESIDENT addressed him as follows :—

Mr. HULKE,—

It is a very pleasant duty which I am called upon to perform in presenting you with the Wollaston Medal, as a recognition of your great services to the study of Vertebrate Palæontology. A member of that honoured profession which has given to Geology—and especially to the biological side of our science—so many diligent and accurate students, you have succeeded, in spite of the labours and anxieties incident to a very active career, devoted to the alleviation of human suffering and the training of others for the same duties, in finding time for very valuable researches among those wonderful forms of Reptilian life which characterize the Mesozoic period. Your hardly-earned vacations have been spent in the search of fossil bones among the mud-flats of Dorsetshire and the sandy cliffs of the Isle of Wight; and in this way you have acquired an exceptional amount of knowledge concerning the exact geological horizons and the mode of occurrence of the fossils you have so admirably described. As by successive discoveries you have been able to add new details to your restoration of the bony framework of *Iguanodon* you must have experienced a joy akin to that of Creation! But though you are best known to the world by these osteological researches, those who, like myself, have had the happiness of being associated with you in the work of this Society, have discovered how wide is the knowledge, how catholic the sympathy, and how keen the interest with which you follow all the manifold developments of our Science.

Mr. HULKE, in reply, said :—

Mr. PRESIDENT,—

I cannot find words adequately to express how highly I value the distinction which the Council has this day, by your hands, conferred upon me. The pleasure I experience in receiving it is in no small degree increased by the words of approbation which have fallen from your own lips. The Wollaston Medal is so truly great a prize, and the work I have done to merit it has appeared to me so little in comparison with that accomplished by the long roll of illustrious men on whom in past time it has been bestowed, that I have fancied that (as occurred to Sir Philip Egerton on a similar occasion) in awarding it to myself the Council may also have desired to mark their recognition of the labours of those who, whilst not devoting the chief part of their time and energy to the culture of that branch of Natural Science for the advancement of which our Society exists, yet endeavour in their leisure hours to do what in them lies to add to our common stock of knowledge. To you, Sir, to the Council, and to the Fellows, I tender my warmest thanks.

AWARD OF THE WOLLASTON DONATION FUND.

The PRESIDENT then presented the Balance of the Proceeds of the Wollaston Donation Fund to Mr. BENJAMIN N. PEACH, F.G.S., and addressed him as follows:—

Mr. PEACH,—

In addition to your services to science as an officer of the Geological Survey of Scotland—and how important those services have been every geologist in recent years has had an opportunity of judging—you have, in conjunction with your colleague and friend, Mr. Horne, devoted your holidays to arduous labour in studying the geology of the Orkneys and Shetlands. Both the glacial and the volcanic phenomena of those islands have been admirably elucidated by your joint researches. But besides your work in the field you have devoted much attention to palæontological investigations; and your discoveries concerning the nature of the Carboniferous Arachnids and their allies have justly excited very great interest. To aid you in the prosecution of such studies the Proceeds of the Wollaston Donation Fund have been awarded to you, and I feel sure that one circumstance in connexion with this Fund will make the award specially welcome to you. In the roll of names of those who have in previous years received this distinction, will be found one, honoured alike by you and by us, that of your lamented father, Mr. Charles Peach.

Mr. PEACH, in reply, said:—

Mr. PRESIDENT,—

I desire to express my cordial thanks for the honour now conferred upon me. The pleasure derived from the pursuit of the researches indicated by you has more than compensated for my labour. It is, however, an additional gratification to me to know that my investigations have been deemed worthy of recognition by the Council of this Society.

 AWARD OF THE MURCHISON MEDAL.

The PRESIDENT next presented the Murchison Medal to the Rev. P. B. BRODIE, M.A., F.G.S., and addressed him as follows:—

Mr. BRODIE,—

Never probably has an award of this Society been made to one who can look back upon so long a record of faithful services to Geology as yourself. It is now 54 years ago since you became a Member of this Society, at a time when the Founder of the Medal which has now been awarded to you, occupied the Presidential Chair.

At the date of your election the 'Principles of Geology' had but just appeared, while Sedgwick and Murchison had not even commenced their researches among the Palæozoic rocks of Western Britain. A pupil of the great Cambridge professor and infected with his enthusiasm, you soon began to contribute to various scientific journals, our own among the number, and in 1845 your valuable 'History of Fossil Insects'—the first treatise of the kind published in any language—made its appearance. A dweller in the provinces, you have shown how the advancement of our Science may best be promoted under those conditions; and in the field-clubs and local societies which have done so much for the study of geology in the West of England, where your home lay, you have long been a prominent and very active worker. Your published papers on a great variety of subjects amount to more than 50, and only last year we were glad to welcome a fresh contribution from your pen, and to hear your clear exposition of it, as you stood before us with eye undimmed and with natural force unabated. The Council of this Society have adjudged you to be a worthy recipient of the Medal founded by their President of 1833.

Mr. BRODIE, in reply, said:—

Mr. PRESIDENT,—

I receive, Sir, this mark of the approbation of the Council with very great pleasure and grateful thanks; and it was more gratifying because it took me quite by surprise. After searching the rocks for more than half a century, and having been a Fellow of this Society for 53 years, it might be expected that I should have done more to enlarge our knowledge of geology; but of course my time was not entirely at my own disposal in this respect, and I could therefore only study Natural Science in the closet and the field during hours of leisure. As a proof that I have not been altogether idle, I have made during that time a large collection of fossils, numbering twenty-three thousand specimens, named and arranged, more or less illustrating every formation in the British Isles. But of course a mere collection of fossils, though having a certain value, is of little worth without an accurate knowledge of the rocks and their organic contents.

The award of the Murchison Medal is especially agreeable to me because I have had many pleasant and instructive days in the field with that distinguished geologist; but I do not forget that at Cambridge I was a pupil of the illustrious Sedgwick, to whom I owe a lasting debt of gratitude for the kind help and encouragement which that great and good professor was ever ready to give to any student anxious to learn. In after years, I can with pardonable pride speak of him as my friend. When I made some of my earlier discoveries of fossil insects and other organisms in the Wealden Purbecks in the Vale of Wardour, I received a letter from him in which he said, "you have made a good hit, go on

and prosper ;” and this medal shows that I have so far done so. It is now more than half a century since I was admitted a Fellow of this Society, just before I went to college, and I know that some hesitation, and very properly, was felt whether I should take up geology to any good or useful purpose. But my kind proposer Mr. Clift, the able Curator of the College of Surgeons, to whom I was well known, and where I often went as a student, would not give me up ; and this proof of the Society’s favour just received shows that he was not altogether mistaken.

In my younger days, when I resided in London, I was a regular attendant at the meetings of this Society, then held in Somerset House, where I was a humble but (I hope) not inattentive listener to the papers read and the discussions which followed, and I recall with pleasure the many intellectual combats between the geological giants of those days. I regret that distance from London and the higher duties of my profession prevent my attending our meetings so often as I could wish ; but though now a septuagenarian, I am thankful to say that I can still hammer the rocks, and that my zeal and love for the noble science we all love so well has not abated ; but I fear I shall not be able to do much more to elucidate their history, though, if younger, this Medal would encourage me to make still further efforts ; and my chief regret is that, for reasons stated, I have not been able to do more to deserve the honour which the Society has kindly conferred upon me. I can only hope that the Society will pardon me for saying so much about myself.

AWARD OF THE MURCHISON GEOLOGICAL FUND.

In handing the Balance of the Proceeds of the Murchison Geological Fund to Dr. HENRY WOODWARD, F.R.S., for transmission to Mr. ROBERT KIDSTON, F.G.S., the PRESIDENT said:—

Dr. WOODWARD,—

The Balance of the Murchison Fund has been awarded by the Council of the Geological Society to Mr. Kidston, to aid him in his important investigations among the fossil plants of the Palæozoic periods. Mr. Kidston’s great knowledge of the extensive literature and the complicated synonymy of these forms is borne witness to by the valuable catalogue which he has prepared under your superintendence, and which was issued only a few months ago by the Trustees of the British Museum ; a large number of remarkable memoirs have also shown his capacity for dealing with this difficult and intricate subject. In seeking to extend our knowledge of the earliest forms of plant-life, Mr. Kidston seems determined to leave no museum unvisited and no stone unturned, if perchance it should be found to exhibit any traces of an ancient vegetation. I will ask

you to convey to Mr. Kidston, with this Award, the hope of the Council that it may be of some assistance to him in enabling him to prosecute his researches.

Dr. WOODWARD, in reply, said :—

Mr. PRESIDENT,—

It is with much pleasure that I am permitted to act as Mr. Kidston's representative here this day, and to receive for him, at your hands, the award of the Murchison Donation Fund. I am sure Mr. Kidston would, had it been possible, have been present in person to receive the award. He writes as follows :—

“ I desire to express my thanks to the President and Council of the Geological Society for the honour they have conferred upon me in acknowledging my labours in Fossil Botany, an honour which I beg to assure them I fully appreciate ; it is one which will act as a stimulus in my future investigations in Vegetable Palæontology. My aim has always been most carefully to work out our palæozoic flora, and in this spirit I hope to continue my labours, trusting that the results may be of use to others.”

AWARD OF THE LYELL MEDAL.

The PRESIDENT then handed the Lyell Medal to Prof. T. G. BONNEY, D.Sc., F.R.S., for transmission to Mr. SAMUEL ALLPORT, F.G.S., and addressed him as follows :—

Prof. BONNEY,—

It is to me an especially gratifying circumstance that it falls to my lot to deliver into your hands for transmission to Mr. ALLPORT the Lyell Medal for the present year. Mr. Allport commenced the microscopical study of rocks at a time when the workers in that department of science were comparatively few, and when the road he had to travel was encumbered with difficulties and stumbling-blocks which have now been, to a large extent, removed by the labours of many earnest and patient workers. It was at that time my good fortune to know him, and to have frequent opportunities of admiring the perseverance and energy with which he carried on his researches. You have yourself from this Chair paid a warm and well-merited tribute to the generosity with which, at that time, he was always ready to assist his fellow-workers. The establishment of one very important principle will always be associated with Mr. Allport's labours, namely, that the apparent differences between the igneous rocks of widely different geological periods are, to a great extent, due to the changes which the constituent minerals of the older rock-masses have undergone since their original formation.

His classic papers on the Archæan rhyolites of Shropshire and the Carboniferous dolerites of various parts of this country furnish the clearest evidence of the truth of this principle, and in several thoughtful and logical essays he has very ably enforced it. On a great variety of other questions connected with Petrology his researches have added largely to our knowledge; and the fine collection of rock-sections now in the National Museum, which were made by his own hands, bear striking testimony to his industry and skill.

Prof. BONNEY, in reply, expressed his regret that Mr. Allport was unable to be present to receive this Medal from the hands of the President, but said that he found some consolation in the fact that he had thus an opportunity of most heartily endorsing what had been said by the President as to the great value of Mr. Allport's own work, and of the kind assistance which he was always so ready to afford to his fellow-labourers in the field of Petrology. Prof. Bonney added that he should best thank the Society by reading to them a letter received from Mr. Allport, in which that gentleman wrote as follows:—

“I much regret to inform you that I shall be unable to attend the Anniversary Meeting of the Geological Society in consequence of the very unsatisfactory state of my health. I venture, therefore, to request that you will kindly express to the Council my very grateful sense of the honour they have conferred upon me by the award of the Lyell Medal.

“It is, I assure you, most gratifying to me that the name of Sir Charles Lyell should be associated with this award; for I have not only ever regarded his character and scientific method with the greatest admiration, but it is undoubtedly to the study of his works that I am chiefly indebted for what little knowledge I possess of the principles of geological science.”

AWARD OF THE LYELL GEOLOGICAL FUND.

The PRESIDENT next presented the Balance of the Proceeds of the Lyell Geological Fund to the Rev. O. FISHER, M.A., F.G.S., and said:—

Mr. FISHER,—

The Council of the Geological Society has awarded to you the balance of the Lyell Fund, in recognition of your great and long-continued services to our science. Nearly forty years ago you commenced your well-known stratigraphical investigations among the Newer Jurassics of Dorsetshire and the Older Tertiaries of the Isle of Wight, your attention being subsequently directed to the Pliocene and Post-Tertiary beds of East Anglia. At a very early period in your career a predilection for the great problems of Physical Geology began to manifest itself; and for dealing with such problems

your mathematical training gave you obvious advantages. In these researches, however, which have been recorded in a number of separate memoirs, worthily crowned by the publication six years ago of your 'Physics of the Earth's Crust,' you have always maintained a just estimate of the proper sphere and necessary limitations of the mathematical method of treatment as applied to such problems. Speaking of the processes you have chosen to employ, you truly remark in the preface to your well-known work, "When it is recollected that, for the most part, we can assign only very hypothetical values to our symbols, it would be affectation to seek close results, which would, after all, have no greater value than those which claim to be only distant approximations." In you we rejoice to see that the geologist has not been altogether lost in the mathematician, and that you have always kept in mind in your researches the weakness no less than the strength of the mathematical method.

Mr. FISHER, in reply, said :—

Mr. PRESIDENT,—

It is no small gratification to me that the Society, through its Council, has expressed approbation of what I have done in the favourite study of a long life. I commenced geologizing almost before I can remember, when my uncle, the Rev. George Cookson, taught me to collect fossils in the cliffs of my native village of Osmington. My work in the field is now finished, and I geologize in my arm-chair out of my inner consciousness, but still, I hope, to some purpose. It appears to be rather these later attempts to unravel some of the physical riddles of our science (although my earlier observations in the field have not been forgotten) which have been thus handsomely recognized; and, indeed, for my own part I think what I have done in applying mathematical methods to these geological problems has been my most useful labour. Nevertheless I feel assured that my earlier work in the field has been of much service to me; for no one can pretend to grapple usefully with the great problems of geology who has not personally studied the actual phenomena. It is in this respect that the greatest physicists of the day fail to give us the decided assistance which they might do had they a more accurate knowledge of the questions to be solved.

We pass on the torch from hand to hand. Some of the ideas which I have tried to work out were suggested by conversations with honoured friends long gone to their rest—Sedgwick, Hopkins, Miller, Phillips, and others. May I hope that when some one now young, in this assembly, receives a similar recognition of a similar life's work, he may think of me as an intermediate link connecting him with those earlier workers?—a link which, whatever may be its intrinsic defects, and however inferior the metal, you have seen fit to gild with the Balance out of the munificent legacy of the great Lyell.

AWARD OF THE BIGSBY MEDAL.

In presenting the Bigsby Gold Medal to Prof. CHARLES LAPWORTH, LL.D., F.G.S., the PRESIDENT said:—

Professor LAPWORTH,—

The late Dr. Bigsby established a Medal to be awarded to one “not too old for further work, and not too young to have done much.” That you admirably comply with the latter qualification every geologist knows; but that your age could possibly fall below the limit prescribed by the founder of this Medal, anyone not personally acquainted with you might be pardoned for doubting. In studying the difficult, but, to geologists, very important group of the Graptolites, in utilizing your knowledge of those remarkable fossils for unravelling the stratigraphical problems presented by the contorted beds of the Scottish Borderland, and in applying the valuable experience thus acquired to the far more difficult examples of involved stratigraphy found in the county of Sutherland, you have exhibited a happy blending of those powers of patient observation and of bold generalization which are equally necessary for the man of science. Those who know you best will feel the least doubt concerning those “favours to come” in the shape of further work, the “lively sense” of which constitutes the staple of our gratitude to you to-day.

Prof. LAPWORTH, in reply, said:—

Mr. PRESIDENT,—

I am deeply sensible of the distinction which the Council of the Geological Society have conferred upon me in awarding me the Bigsby Medal; and I am grateful, indeed, for the generous words in which you have referred to my geological work. If anything could add to the gratification with which I accept this award, it is that I receive it from the hands of one who, since the reading of my first paper before this Society, has been a staunch friend and a sympathetic adviser. I am afraid that the Members of this Society are a little inclined to rate my geological labours somewhat higher than they deserve, and I regard this Medal less as a reward for what I have done in the past than as a stimulus and encouragement for the future. The pursuit of original research has always appeared to me to be the highest and most pleasurable of enjoyments—and none the less pleasurable, as it has for years been associated in my mind with the unfailing interest, sympathy, and friendship accorded me by the Members of this Society. My leisure and means for work of this kind are, however, but small; but I am confident that there is no need for me to assure the Society that such leisure and powers as I possess will in the future be given to the service of that science to which we are all devoted.

THE ANNIVERSARY ADDRESS OF THE PRESIDENT,

Professor J. W. JUDD, F.R.S.

GENTLEMEN,

My next duty is the sad one of glancing over our muster-roll, and taking note of the gaps left in our ranks by those who, since our last Anniversary, have fallen before the hand of death.

In the Right Honourable WILLIAM WILLOUGHBY COLE, third EARL of ENNISKILLEN, we have lost a link with the past. He was elected a Fellow of this Society so far back as the year 1828, and at the time of his death was with one exception our oldest Fellow—that exception being the truly Venerable Archdeacon Philpot, who was elected in 1821, and who still survives as the ‘father of the Society.’ Lord Cole, as he was called before the death of his father in 1840, was born in 1807, and was educated at Harrow, and at Christchurch, Oxford. At the University he came under the influence and teaching of Buckland and Conybeare, and formed a friendship, which became a life-long one, with the late Sir Philip Egerton. The two friends determined to devote their attention to the collection and study of fossil fishes, and with this end in view they travelled together to Solenhofen, Æningen, Monte Bolca, and other places, where the traces of ancient ichthyic life might be sought for. Among the stores of specimens thus patiently collected during many years, both at home and abroad, Agassiz found ready to his hand the materials for his famous monographs. The Cole and Egerton Collections, now appropriately united, occupy one of the galleries of our National Museum, forming the most suitable and enduring monument of the two friends, who were indeed “lovely and pleasant in their lives.”

Lord Enniskillen served upon the Council of this Society on many occasions between the years 1832 and 1867. Of a singularly modest disposition, he did not contribute largely to the literature of science, his only published memoir being a catalogue of the Agassizian types, no less than 154 in number, which existed in his collection; this memoir concludes with a characteristic invitation to ichthyologists to come to Florence Court to study his collections.

In spite of his sad infirmity, a constantly increasing weakness of vision, he found pleasure to the last in the pursuit of his favourite

studies, passing away on the 21st November, 1886, in the 81st year of his age. Until disabled by age and blindness, his tall form and cheerful voice were among the most familiar to those who frequented the Society's apartments; and amid the older Fellows of this Society, a large circle of friends look back with sadness when they remember the hearty joviality, the warm friendship, and the unbounded hospitality which distinguished this "fine old English gentleman."

SIR CHARLES JAMES FOX BUNBURY, Bart., was the son of Sir Henry Bunbury (one of the earliest members of our Society, who contributed a paper to the 'Transactions' in 1822) by his first wife, who was a niece of Charles James Fox. Charles Bunbury, who was born at Messina in 1809, appears to have early imbibed a taste for botanical studies, and after leaving Trinity College, Cambridge, he at the end of 1837 accompanied his friend Sir George Napier to the Cape of Good Hope, making during his year's residence in that colony a number of excursions into the interior in search of rare plants. The results of these researches were published by Sir William Hooker, in the 'London Journal of Botany;' and in 1848 there appeared the 'Journal of a Residence at the Cape of Good Hope' by Mr. Bunbury, with an Appendix by his friend Sir John Herschel. After his return to England, Mr. Bunbury married, in 1844, Frances, the second daughter of Mr. Leonard Horner, and the sister of Lady Lyell. He still continued to devote much time to botanical pursuits, and took up very eagerly the study of fossil plants. At one time he appears to have contemplated either the bringing out of a new edition of Lindley and Hutton's well-known treatise, or the preparation of a fresh work on something like the same lines. Although this design was never carried out, a number of valuable papers on fossil plants, contributed by Mr. Bunbury to our own and other Journals, serve to show what qualifications he possessed for such a task. As the describer of plants collected by Lyell during his two visits to the United States, and as the constant adviser of the author of 'The Principles of Geology' upon botanical questions, Sir Charles Bunbury will perhaps be best remembered by geologists in the future. He accompanied Lyell to Madeira in 1853 and studied the botany of the island while his friend was occupied with the geology. He at one time took an active part in the management of the affairs of this Society, of which he was elected a Fellow in 1837; between 1846 and 1862 he frequently occupied a seat at the Council table, and from 1847 to 1853 was our Foreign

Secretary. Sir Charles Bunbury will always be recognized as one of the ablest pioneers in the study of fossil plants.

Mr. GEORGE BUSK was born in the year 1807. Destined by his father, who resided in St. Petersburg, for the medical profession, he early showed signs of those scientific tastes by which his after life was distinguished. On the completion of his medical education he was appointed surgeon to the Seamen's Hospital-ship 'Dreadnought,' and after 25 years of useful labour he retired from that post with the object of devoting himself entirely to scientific pursuits. One of the first-fruits of the leisure thus secured was seen in his 'Catalogue of Polyzoa in the British Museum,' which appeared in 1852-54, and his splendid monograph on the fossil Polyzoa of the Crag, published by the Palæontographical Society in 1859. This work had been originally undertaken by Jules Haime, and the materials for it were found in the rich collections of Searles Wood and Bowerbank. In this work Mr. Busk showed the value of an exact and extensive knowledge of recent forms to a palæontologist in explaining the fossil representatives of any group, for on all questions connected with the anatomy and physiology of the lowest division of the molluscan series Mr. Busk was recognized by biologists as the highest authority.

In 1863, accompanied by several other English geologists, Mr. Busk attended the Conference called together to discuss the question of the age and authenticity of the human jaw found at Moulin Quignon, and in this way his attention appears to have been directed to a very important class of geological problems. In the following year he proceeded to Gibraltar with Dr. Falconer, for the purpose of investigating the fauna preserved in the bone-caves of that place.

From this time we find Mr. Busk devoting much of his time and attention to the study of the post-Tertiary Mammalia derived from bone-caves and similar situations. His papers on the relations of the extinct Bears to recent species are well known, and he also wrote papers on *Elephas*, *Hyaena*, and *Rhinoceros*. He gave his valuable assistance to Professor Prestwich in the study of the bones found in the Brixham Cave, and to Colonel Lane Fox by describing the bones found in the valley-deposits of Acton and Turnham Green.

During the latter part of his life, Mr. Busk took much interest in ethnological questions, and was an active member of the Anthropological Institute.

This is not the place for attempting to estimate the value of Mr. Busk's numerous contributions to Biological Science, or of his active

and useful career in connexion with the College of Surgeons and other Medical Institutions. The judgment of his contemporaries upon his work was manifested by his election in 1850 as a Fellow of the Royal Society, and by his receiving a Royal Medal from that Society in 1871; he also served as a Member of the Council and Vice-President of the Royal Society. Of our own Society he was elected a Fellow in 1859, and he twice served upon the Council; in 1878 the Lyell Medal was awarded to him, and the year before his death Mr. Busk received the "blue ribbon" of our Society in the form of the Wollaston Medal. During the latter years of his life he filled the office of Inspector of Medical Schools and Physiological Laboratories, under the Cruelty to Animals Act. After a lingering illness he passed away on the 10th of August, 1886, in his 80th year.

All who knew Mr. Busk will acknowledge the justice of the following estimate of his character by his life-long friend Dr. Allman: "A single-minded, true-hearted man, a warm friend, and an able and accomplished naturalist."

In those of whom I have already spoken we have had to sigh over the passing away of men whose strength had already been quenched in the labour and sorrow of fourscore years; but in JOHN ARTHUR PHILLIPS we have lost one of our most active members, fallen untimely,—his work, as we fondly thought, still far from finished.

Mr. Phillips was born, in November 1822, at Polgooth, near St. Austell, Cornwall, his family being connected with the important tin-mine at that place, and it was in Cornwall that the days of his early education were passed. When twenty years of age, the true bent of his mind was indicated by his preparing for the Annual Exhibition of the Cornwall Polytechnic Society a specimen of fine lace delicately covered with a deposit of copper, by the then new process of electro-metallurgy, and for this he received the first prize. On this occasion young Phillips would seem to have made the acquaintance of Robert Were Fox, and for a time to have assisted him in making experiments upon the electrical condition of mineral veins.

Feeling very strongly, however, the necessity of a thorough scientific training, Mr. Phillips determined to go to Paris and study at the Ecole des Mines, there being at that time no institution in this country where a similar course of instruction could be obtained. After passing through the curriculum of the celebrated French school and receiving its diploma, Mr. Phillips obtained employment

for a time in one of the largest French collieries, where he gained considerable experience in conducting mining operations.

On his return to England, Mr. Phillips was appointed Chemist to an Admiralty Commission, then engaged in making inquiries concerning the coals best suited for use in marine boilers, this commission being under the direction of Sir Henry de la Beche and Dr. Lyon Playfair. The completion of this work set Mr. Phillips free to establish a private chemical laboratory, and to enter upon the profession of a consulting engineer in connexion with mining and metallurgical operations. In this capacity he, during the next twenty years of his life, enjoyed abundant opportunities for travel and study—gathering vast stores of knowledge concerning the mode of occurrence of all kinds of mineral deposits in various parts of North America, Europe, and Northern Africa. The fruits of his wide experience on technological questions were given to the world in a number of papers published in the ‘*Chemical News*,’ the ‘*Philosophical Magazine*’ and other journals, but more especially in several well-known treatises. In 1852 he wrote, for the ‘*Encyclopædia Metropolitana*,’ a “*Manual of Metallurgy*,” which after passing through three editions, gave place to the more extended ‘*Elements of Metallurgy*,’ published in 1874, of which a second edition was being prepared with the cooperation of our Vice-President, Mr. Bauermann, at the time of the author’s death. Mr. Phillips had at an early date also written instructions on Gold-mining, based on his extensive experience in California and other countries, and in 1867 appeared his very valuable treatise ‘*The Mining and Metallurgy of Gold and Silver*.’ Mr. Phillips’s most important scientific work, however was ‘*A Treatise on Ore Deposits*,’ which was published as recently as 1884. In all of these works, and especially the last, geologists will find large stores of valuable information, arranged in a skilful manner; and everywhere they must be struck with the rich fund of knowledge which was at the command of the accomplished and widely-travelled author.

Mr. Phillips had already passed the period of middle life before he found an opportunity of devoting himself to those valuable petrographical researches with which his name will be chiefly identified by geologists in the future. But he came to this work with a mind stored with facts and observations gathered in his numerous journeys, with the skill of a practical chemist and the experience of an excellent mineralogist; and all these were combined, in spite of his fifty years, with an almost boyish enthusiasm.

In 1872 he joined this Society, and at once perceiving the land of promise lying open to the student of the microscopical structure of rocks, he set to work to educate himself in making transparent rock-sections. I well remember his ardour in these early days of his work, and the glee with which he assured me that he had so far perfected his arrangements for rock-slicing and grinding that he was ready to supply me, if I needed them, with sections "as large as slices of bread and butter"!

The fruits of this devotion of his well-earned leisure to original research were soon seen in the valuable series of papers on the rocks of his native county, published by Mr. Phillips between 1875 and 1878. Taking as the basis of his studies the field-observations of De la Beche, for whose work he always felt and expressed the greatest admiration, he prepared a series of very remarkable monographs, dealing especially with the very heterogeneous group of rocks that had been called "Greenstones," which he clearly showed to include materials of very different origin.

Mr. Phillips was by no means the man to think that the microscope—valuable as he proved it to be in his studies—ought to supplant all other methods of research; on the contrary, he seems to have been always on his guard against permitting a very useful servant, as the microscope undoubtedly is, to become a despotic master. Every one who reads his memoirs must be impressed alike by his many-sidedness and his industry. In his papers on the Cornish rocks were included the results of over sixty complete chemical analyses, which he performed in his own laboratory; he made many hundreds of slices of the rocks, cutting them in various directions as best suited his purpose, and he visited and revisited the localities till he had satisfied himself, beyond possibility of doubt, of the correctness of his field-observations.

In one respect, perhaps, Mr. Phillips scarcely did himself full justice. Among the laborious and conscientious details of his observations many very valuable generalizations may be found buried which well deserved to be brought out into greater prominence. His observations upon the paramorphic change of augite into hornblende, and the various ways in which this change takes place, his recognition of the fact that massive augitic rocks are converted into hornblende-schists, his demonstration that many of the liquid-cavities found in quartz and other minerals are of secondary origin, these were all announced and their suggestiveness fully appreciated by this careful and honest worker. His researches among

the Cornish rocks, though the principal, were by no means his only ones. A very thoughtful and suggestive essay on "The Physical History of Grits and Sandstones," and another on "Enclosures in Granite," in which he admirably investigates the nature and origin of the different varieties of these well-known phenomena, must be still fresh in the mind of every one present.

Mr. Phillips was elected a Fellow of the Royal Society in 1881. He died suddenly, from an affection of the heart, on the 4th January, 1887, and was buried at St. Mewan's, Cornwall.

His sturdy integrity of character, combined with great knowledge of the world, made Mr. Phillips an invaluable member of the Council of this Society; and during the last two years he worthily filled the office of Vice-President. His generosity in communicating his results to fellow-workers and in aiding them out of his vast stores of knowledge are familiar to all of us. Those who know the amount of time and labour involved in making accurate analyses of rocks and minerals can best appreciate the readiness with which he at all times offered to undertake this task for his friends. Although I know that many around me must cherish similar recollections of the kindness of heart which distinguished our late colleague, I cannot forbear referring to my own personal experience of it. His early association with Sir Henry De la Beche secured for the Royal School of Mines (the child of De la Beche's old age) the warmest sympathy of Mr. Phillips; he had felt the want of such a school in his own youth, and he gladly sent his only son to be educated there. Both my predecessor, Professor Ramsay, and myself have had many proofs of this kindly interest; and any particularly instructive specimen or section was to the last brought and presented with the kindly intimation "You will find it of some use in teaching your young men"! It will be long, indeed, before we forget the tact and courtesy, the soundness of judgment, and the warmth of heart which ever distinguished our departed friend.

In Mr. HENRY MICHAEL JENKINS we regret the loss of one to whose great literary abilities, business habits, and marvellous energy our Society has in the past been greatly indebted. Born near Llan-daff, on the 30th of June, 1841, Mr. Jenkins had the misfortune to lose his father in infancy, and was compelled to enter very early upon the stern battle of life—and this in spite of an asthmatical affection which, early developing itself, compelled him, while still a lad, to take a voyage to the West Coast of Africa. His great capa-

city for business had already manifested itself when, in 1861, he fortunately attracted the attention of Professor T. Rupert Jones, then our Assistant-Secretary and Editor; and, upon his recommendation, young Jenkins was appointed, in the first place a temporary and afterwards a permanent assistant in the library and museum. So diligently did he devote himself to the study of various branches of science, by attending the classes at King's College during his leisure hours, and so rapidly did he acquire a knowledge of foreign languages and skill in literary work, that, when Professor Rupert Jones retired in 1862, Mr. Jenkins, though at that time only 21 years of age, was appointed by the Council to the responsible post of Assistant-Secretary and Editor. Very admirably did he justify the confidence thus placed in him, and for six years he served the Society with conspicuous ability, not only editing the Journal, but, during a part of the time, managing with great skill the financial affairs of the Society.

It was during this time that Mr. Jenkins began to devote his attention to the study of the Tertiary and Recent Mollusca, and he contributed papers on this and other subjects to our Journal, to the 'Quarterly Journal of Science,' to the 'Geological Magazine,' and to other periodicals, many of these papers being of the highest promise. With Professor P. M. Duncan, F.R.S., he was associated in the study of the remarkable fossil known as *Palaocoryne*, the description of which was published by the two authors in the 'Philosophical Transactions' for 1869.

So greatly did the energy and ability of Mr. Jenkins impress all those with whom he came in contact, that at the end of 1868 he was selected for the important and responsible post of Secretary to the Royal Agricultural Society of England, and editor of that Society's journal. Into the duties connected with this new sphere of labour, where his great power of organization and literary facility found such ample scope, he threw himself with characteristic energy; but to these new fields of labour we must not follow him. I cannot, however, forbear quoting the appreciative remarks of one of our own Fellows, Professor Fream, concerning the manner in which Mr. Jenkins made his geological knowledge and experience of service to him in his new career as an agriculturist:—

“As might be expected, the fruits of his early scientific experience are discernible in many of his papers. Particularly is this the case in his clear and accurate descriptions of the geological features of the districts of the farms he reported upon in 1869, of

the prize-farm district around Oxford in 1870, of the geology of Belgium, and of Sweden and Norway. In his report upon Denmark he pointed out how each of the geological formations in that country is characterized by a distinctive system of agriculture."

Mr. Jenkins was elected a Fellow of this Society in 1863, and, in spite of ever multiplying and distracting occupations, he always took the warmest interest in our affairs. To the trying disease against which he had struggled so manfully, he at last fell a victim, passing away last Christmas eve at the early age of 45. Few men have accomplished so much work in so short a time and under such adverse conditions. At his open grave the prince who presided over the great Society which he served so faithfully, and the farmers and peasants whose interests he had spent so large a share of his life in promoting, were alike represented; but among those who mourned his loss there were none who felt it more keenly than his early friends and fellow-workers of the Geological Society.

DR. HARVEY BUCHANAN HOLL was born at Worcester on the 28th of September, 1820, and received his early education in that town and at Birmingham. When only 17 years of age he met Sir Henry De la Beche, whom he accompanied for six months while engaged in his important studies of the geology of Cornwall and Devon. De la Beche seems to have formed such a high opinion of the abilities of the young geologist that he recommended him to the notice of Professor Rogers, and the result was that young Holl found employment for three years on the Geological Survey of Pennsylvania, afterwards travelling for a year in the United States on his own account. From the pupil of such masters as De la Beche and Rogers good services to geological science might be looked for; nor was the expectation disappointed. After returning to England and taking his medical degree, Dr. Holl accompanied the British Army to the Crimea, remaining there till the end of the campaign. For some time after his return he practised his profession in London; but in 1862 he retired to Malvern, and in the same year became a Fellow of this Society. It was then that he found time for the carrying out of his valuable studies on the geology of the Malvern Hills. In opposition to Murchison's views, he maintained the non-intrusive character and the Archæan age of these rocks; constituting himself a pioneer in the study of those isolated portions of the pre-Cambrian floor of Britain which have been uncovered by denudation, and which, during recent years, have attracted so large a share of the attention of geologists.

Other important papers on stratigraphical geology which he contributed to our Journal were those on the correlation of the several subdivisions of the Inferior Oolite in the Middle and South of England, and on the older rocks of South Devon and Cornwall. He also published a number of papers on fossil sponges and Entomostraca, the latter with the cooperation of Professor T. Rupert Jones.

When ill-health prevented him from continuing his work among the Field-Clubs of the west of England, of which he had so long been a most active member, he retired to his native town, still with microscope and pencil carrying on his labours among the minute fossils which he had studied with such loving care.

Dr. Holl succumbed to the effects of heart-disease on September 11th, 1886, and in him we have to mourn the loss of one who has greatly contributed to the advance of geological knowledge in a number of widely different fields.

In Mr. CALEB EVANS we have lost another of those hard-working amateurs to whose exertions the advance of geological science has been so largely due. He was born in July 1831, and educated at University College School. He lost his father while still young, and after being educated as a solicitor, received in the year 1852 an appointment in the Chancery Pay Office, which he retained till 1882, when compelled to retire through ill-health. Mr. Evans was a remarkable example of what can be accomplished by an ardent student of Nature, even when his lot in life happens to be cast in the heart of this human wilderness of London. Having taken up the study of geology in 1855, he found among the excavations for the new sewers in this city, and in unfinished cuttings of railways leading from it, abundant opportunities for the collection and study of fossils, supplementing this work by researches carried on at the seaside during his vacations. In this way he accumulated a large and valuable collection, some important type specimens from which were bequeathed by him to this Society. He took a very active part in the work of that very useful body the Geologists' Association, of which he was one of the earliest members, and to its Proceedings nearly all his papers were communicated. His most notable contribution to geological literature was the well-known paper "On some sections of Chalk between Croydon and Oxted, with Observations on the Classification of the Chalk," in which there was made the first attempt in this country to base a classification of the beds of the Chalk upon palæontological data. This memoir, which

essayed to do for England what Prof. Hébert did for France, has formed the basis of much excellent work since accomplished by M. Barrois, Mr. Jukes-Browne, and other geologists. With this important question of the classification of the Chalk strata Mr. Evans's name will ever be honourably associated, giving him as it does an undisputed claim to a niche in our Geological Temple of Fame. Happy to the end in the study of Nature, to which he devoted his last years of physical weakness and decline, he passed away in his home at Hampstead on the 16th September, 1886.

From a remote Devonshire rectory we have received two papers, short but full of promise, from the pen of the Rev. WILLIAM DOWNES. These papers showed that the Society had secured, by his election in 1872, the aid of an able student of the very interesting Cretaceous rocks of the West of England, and one who had exceptional opportunities for their detailed investigation. We have, alas! to record his death on the 12th October, 1886, at the age of 48.

Professor FREDERICK GUTHRIE, F.R.S., the eminent physicist, who died on the 21st October, 1886, had been for some years a Fellow of this Society. Some of his researches upon physical questions, especially those bearing upon the continuity between the states of solution and fusion, have an important bearing on geological problems, and these their author clearly saw and forcibly pointed out. Born in London in 1833, Dr. Guthrie was educated at University College School and University College, receiving a further chemical training in the Universities of Marburg and Heidelberg. Acting first as demonstrator to Dr. Frankland at Manchester, and then to Sir Lyon Playfair at Edinburgh, he became Professor of Physics at Mauritius; afterwards, succeeding Dr. Tyndall, he obtained the appointment which he so worthily filled at the time of his death, that of Professor of Physics in the Normal School of Science and Royal School of Mines. His death at the early age of 52, which resulted from a morbid growth in the throat, has deprived science of an enthusiastic and ingenious student, and his colleagues of a much-loved friend and coadjutor. One of these, who knew him well, has aptly compared his whimsical admixture of simplicity and wisdom, of kindliness with pungent but never caustic humour, to the immortal character of Uncle Toby.

In Mr. ARTHUR GROTE we have lost one of those valuable members who, after long service in our Indian Empire, return with wide knowledge and ripe experience, ready to be placed at the service of

the scientific societies of their native land. Mr. Grote, who was a younger brother of the historian, was born on the 29th November, 1814, at Beckenham in Kent; from 1833 to 1868 he was a member of the Indian Civil Service, at the end of his career occupying one of the highest administrative posts in the Bengal Presidency. He joined this Society in 1846, and after his retirement from official life found satisfaction for his scientific tastes and sympathies in attending the meetings and assisting in the administration of the affairs of the Royal Asiatic, the Zoological, and the Linnean Societies, as well as of our own. A man of charming manner and most amiable character, his presence will be missed by a large circle of scientific friends.

From our Foreign list we have been compelled to erase the honoured names of Abich, Guiscard, and Cornet.

Dr. HERMANN ABICH was born in Berlin, 11th December, 1806. He first became known to the scientific world by his careful chemical analyses of the spinels and other minerals; but he afterwards devoted his attention to the study of volcanic phenomena, and in this connexion his investigations on the chemical composition of the gases of fumaroles and of the deposits which are found on the sides of volcanic vents are of especial value. He was a warm advocate of Von Buch's theory of "Erhebungscratere," and though few geologists at the present time will be found ready to accept his arguments on this subject, every one must admire the careful observations on the structure of volcanoes which he brought together in several well-known works. In 1837 appeared his '*Vues Illustratives de Phénomènes Géologiques observés sur le Vésuve et l'Etna pendant les Années 1833 et 1834,*' and in 1841 his '*Geologische Beobachtungen über die Natur und den Zusammenhang der vulkanischen Bildungen.*' Having been appointed Professor of Mineralogy at Dorpat, Abich's attention was directed to the study of the geology and mineralogy of different parts of the vast Russian Empire. He subsequently removed to Tiflis, and from that time his studies were chiefly devoted to the elucidation of the geological structure of the Caucasus and surrounding districts. So long ago as 1857 he was elected a Foreign Member of this Society. The last few years of his life were spent at Vienna, where he was engaged in embodying the results of his numerous researches in a great monograph entitled '*Geologische Forschungen in den kaukasischen Ländern,*' of which one part only has as yet appeared. He passed away on July 1st, 1886, in his 80th year.

GUGLIELMO GUISCARDI, who was born in Naples in March 1821, was educated for the profession of an architect. When he was 24 years of age, however, the meeting of a Scientific Congress at Naples, which he attended in order to learn something about building-materials, seems to have directed his attention to the interest attaching to geological studies. Entering the class of the veteran mineralogist Professor Scacchi in the University of Naples, Guiscardi soon became the most distinguished of his pupils. The revolution of 1848 found the young geologist in the ranks of the army which endeavoured to overthrow the Bourbon dynasty in Naples; but on the failure of that attempt, he retired to a private life of intense study for the next twelve years. The victory of the national cause, to which he was so greatly attached, came at last, however, and he was then in 1860 appointed Professor of Geology in the University of Naples, a post which he retained till the time of his death. Professor Guiscardi was a man of very wide culture and extensive knowledge, as was shown by his palæontological papers on the genera *Nerita* and *Aturia*, on the family of the Rudistes, and those on the fossils found in blocks ejected from Vesuvius, by his petrographical papers on the rocks of Vesuvius and the Phlegræan fields, and by his chemical researches on the gases escaping from volcanic vents. He was elected a Foreign Correspondent of this Society in 1879. Many of our members can bear testimony to the cordiality with which foreign students of his science were always welcomed at Naples by our esteemed Correspondent, who ever showed himself ready to assist them in their researches; I can myself never forget the kindness which I received from one with whom I contracted a warm friendship. For some years past an affection of the eyes had caused him much suffering and anxiety, and he died at Naples on the 11th December, 1885, at the age of 64.

FRANÇOIS LEOPOLD CORNET was born at Givry in Belgium on the 21st February, 1834. At the age of 16 he entered as a student the "Ecole des Mines" of Hainault, and, obtaining his diploma in 1853, became a mining engineer. For some years he was engaged in the direction of the operations of several coal-mines, and in this capacity he introduced two notable improvements into the working of the Belgian collieries, namely the employment of compressed air as a motive power, and the use of the endless chain for transport purposes. Forming the acquaintance of another mining engineer, M. A. Briart, now an esteemed Foreign Correspondent of this Society,

M. Cornet entered with him into a scientific partnership, and from this time forth all the valuable geological researches which they carried on were published under their joint names. In 1865 they announced the discovery of an older series of Eocene strata than had hitherto been recognized, and in subsequent papers the stratigraphy and palæontology of these most ancient members of the Tertiary series and of the underlying Cretaceous rocks were carefully elaborated. These papers were, however, interspersed with others bearing upon anthropological questions and on the Carboniferous strata of Belgium. During the later years of his life M. Cornet was engaged in developing the remarkable industry which had arisen in Mons through the working of the phosphate beds of the Chalk. In 1883 he was elected one of our Foreign Correspondents, and only last year he contributed to our Journal a very valuable paper describing the Cretaceous strata of Mons which contain the remarkable deposits of phosphate of lime. Little did we think at the time that this was the last communication which would come from his hands, but in January last we received the sad news of his death at the age of 53.

The Report of the Council indicates a very flourishing condition of our affairs—both in respect to the number of our Fellows and the state of our finances; but I need scarcely remind you that, gratifying as these circumstances are, the true index of the well-being of our Society is to be found in the amount and importance of the original work done by its members, as shown by the contents of our annual volume. During the past year the number of papers submitted to the Society has been at least as large as in any previous year, and I am persuaded that when tried by the test of time there will be found to be no falling off in their scientific value.

In a year when so much attention has been directed to our Colonial and Indian possessions, and when we have had the pleasure of greeting in this room some of our most active members, who are citizens of the Greater Britain beyond the seas, it is not surprising that communications bearing on the geology of these British “outliers” have been as numerous and valuable as they were welcome.

The Societies which occupy common ground with ourselves—our valued auxiliaries the Palæontographical Society, the Mineralogical Society, and the Geologists’ Association—have well kept pace in the ever-forward movements of the past year; the numerous provincial Geological Societies and Field-clubs have all aided in

swelling the strength of the advance; while the 'Geological Magazine,' appearing at shorter intervals than our own Journal, has satisfied all the requirements of the light skirmishers of our army.

The two great state-supported institutions to which Geologists always look for aid in their work have not been wanting in effort since our last Anniversary.

The Geological Survey has already completed the one-inch map of England, that of Ireland will be finished during the next year, while their last great remaining task—the important one of mapping the Scottish Highlands—is being vigorously attacked both from the north and the south. Valuable work of revision in the country already surveyed is also being pressed forward, the most notable achievement in this way during the past year being the complete confirmation by Mr. Clement Reid of Professor Prestwich's important discovery, which was made in 1857, of the existence of Pliocene outliers on the North Downs.

Nor has the Natural History department of the British Museum been behind its sister institution in the work it has accomplished. The rearrangement of the palæontological and mineral collections, under more favourable conditions of space and light, has gone on steadily; valuable monographs like those of Dr. Hinde on the fossil sponges, and of Mr. R. Etheridge, jun., and Mr. P. H. Carpenter on the Blastoidea have been issued; and catalogues like those of Professor Rupert Jones on the Foraminifera, of Mr. Lydekker on the Fossil Mammalia, and of Mr. Kidston on the Palæozoic plants have been published. Among the good work done by some of our members who direct the affairs of the Museum, we must not overlook the admirable and successful efforts which are being made to increase the value of the collections for educational purposes. The specially arranged collections for the guidance of students and beginners, and the cheap and accurate guide-books now issued, afford sufficient evidence that the Director and Keepers of the Museum are alive to a very urgent national want. From among those whose interest has been excited and whose earliest cravings for information have been supplied by such means as these, our own and other societies must look for future recruits. It may not therefore be uninteresting to mention that of the cheap illustrated guide to the Palæontological Galleries, prepared by Dr. Woodward in 1880, four editions have already appeared and over 12000 copies have been sold; while of Mr. Fletcher's Guide to the Mineralogical Gallery, with its charming introduction to the study of Mineralogy, no less than 4000 copies have been disposed of within a very short period.

At the last meeting of the British Association, held at Birmingham, geological questions occupied a full share of the attention of its members. In addition to the comprehensive address of the President, Sir William Dawson, which dealt with very complex geological problems, and the lucid discourse of my predecessor in this Chair, who supplemented the reviews which he has given in this room of the results of the application of microscopic methods to the study of igneous and metamorphic rocks respectively by an equally striking and suggestive treatment of the aqueous rocks from the same point of view, Geologists have to thank the distinguished mathematician, Professor G. H. Darwin, for the comfort afforded to them in his very modest and thoughtful address. Should certain more recent utterances from the mathematical fold have produced a moment's disquiet in any faint-hearted Fellow of this Society, I can confidently recommend to him the perusal of Professor Darwin's cautious and reassuring essay.

The commencement of several important undertakings have marked the present year in the annals of geological science.

Those who desire to perpetuate the memory of the late John Morris could not possibly have chosen a better method for doing so than that of promoting the publication of a new edition of his invaluable 'Catalogue of British Fossils.' In the third of a century which has elapsed since the second edition appeared, the progress of palæontological research has been so rapid that no single individual—even if gifted with the encyclopædic mind of Morris himself—could possibly expect to cope with it. A number of able workers have, however, rendered themselves responsible for the cataloguing of the several groups which they have especially studied, while Dr. Henry Woodward has undertaken to act as Editor. Professor Morris's nearest surviving relative having engaged to supply the necessary funds, and the Syndics of the Cambridge University Press having arranged to print it, we may hope at no distant date to see this important work issued.

Mr. Teall, in his 'British Petrography,' has entered upon a task, the accomplishment of which was much needed, and which is well worthy of the sympathy and support of all geologists. He proposes to prepare descriptions, to be illustrated by carefully executed coloured plates, of the chief types of our British rocks. How competent Mr. Teall is for the execution of such an undertaking, he has given ample proof in several papers laid before this Society. In these days of rapidly increasing petrographical literature, every one must

feel indebted to the author for the careful manner in which he follows up the comparison of our British types with those described by foreign petrographers.

Mr. Mellard Reade, who is so well known to geologists by his thoughtful and suggestive addresses to the Geological Society of Liverpool, has found an admirable subject, which he has treated with great skill and no little originality, in his 'Origin of Mountain Ranges.'

To the manner in which the advancement of geological science is being promoted by the various societies in other countries, and the surveys undertaken by foreign States, I can do no more than barely allude. Everywhere we have to note the same steady and sustained efforts, before which the clouds that have enveloped the story of former times are being gradually rolled back, and the light of knowledge is illuminating the obscurest problems connected with the past history of our globe.

In the advance of an army through an unknown and difficult country there must always be some risk of the communications between its several divisions breaking down, and of their power for effective cooperation becoming impaired; more especially does this danger arise when the army is large in its numbers, complicated in its organization, or swift and sudden in its movements.

Now that vast host of geological investigators which is ever pressing forward to conquer new realms of knowledge is distinguished among all the armies of science by the rapidity of its evolutions; the history of Geology is the chronicle of a brilliant succession of forced marches. It may therefore be prudent if, from time to time, we pause to look around us and to inquire if there be any chance of the centre of our army, while engaged in steadily grappling with the vast physical problems which confront it, losing touch with either of its wings—that which is composed of the cultivators of the mineralogical sciences on the one hand, or that which is formed by the students of the biological sciences on the other.

From that position of elevation and of observation in which I find myself placed by your indulgent suffrages, it has occurred to me that I may possibly render a service by reporting to you the main features of the field of conflict, so far as it is given to me to discern them.

In attempting such a survey, I of course do not forget that a just idea of so vast a field can scarcely be obtained from any single standpoint; but I am satisfied that no better vantage-ground could possibly be found for the purpose than that afforded by this Chair. Without for one moment forgetting the workers belonging to other countries or connected with kindred associations, I may claim for this Society that it has ever taken a foremost place in promoting the progress of geological science; that the initiative in many of its most remarkable advances has been due to our Fellows; and that all the leading episodes of its short but brilliant history will be found faithfully reflected in our publications.

It is my purpose to-day to invite your attention to the past and present relations between Geology and the Mineralogical Sciences.

The geologists of this Society stand in no need of the reminder that "their father was a mineralogist." That little band of enthusiasts who, just eighty years ago, constituted themselves the nucleus of the Geological Society of London were before all things mineralogists; and the initial object of the formation of the Society was a purely mineralogical one, that of securing the publication of Count Bournon's laborious treatise on the varied forms assumed by the crystals of calcespar. Little could its original members have anticipated many of the directions in which the work of the Society was destined to develop itself.

An examination of the first series of our 'Transactions,' published between the years 1811 and 1821, will show that all the really valuable and enduring work of the Society, during this first epoch of its history, was either mineralogical or petrographical. Looking back on that work, we may indeed feel proud of the achievements of these founders of our Society. We find Wollaston engaged in devising his beautiful contrivance for measuring the angles of crystals, and William Phillips illustrating the value of the reflecting goniometer by accumulating a great mass of accurate determinations; we see Whewell, and afterwards Miller, labouring to place on a secure basis the mathematical methods best adapted for the discussion of these measurements; while Brewster and Herschel are steadily feeling their way towards the pregnant generalization that the geometrical forms of crystals are but the outward and visible signs of an inward molecular structure, which becomes clearly manifested by its action upon polarized light; at the same time Macculloch, bringing to bear on his studies in the field a vast amount of accurate chemical and mineralogical knowledge, is found

engaged in laying the foundation in this country of the study of rocks.

If now we turn to the second series of our 'Transactions' and the earlier volumes of our 'Journal,' published between the years 1824 and 1858, we shall perceive a startling falling-off in the contributions to mineralogical science, too sure a sign of that neglect and almost contempt with which Mineralogy had come to be regarded by the geologists of that period.

This unfortunate result was doubtless to some extent due to the powerful counter-attraction exercised by Stratigraphical Geology, which had received such a remarkable impetus from the labours of William Smith, and of Palæontology, which was daily being enriched by the discoveries of Cuvier, Conybeare, Buckland, Mantell, and Owen. But it must, at the same time, be confessed that many mineralogists had at that period permitted themselves to be betrayed into a position of more or less pronounced antagonism to all the later developments of Geology, and their science in turn had come to be regarded by geologists with feelings of suspicion and distrust.

Perhaps I cannot better illustrate the relations which had grown up between the geologists and mineralogists of that day than by referring to an incident which was related to me by Charles Darwin, shortly before his death, as having exercised an important influence on his own career as a geologist. While Darwin was a student at Edinburgh, it was the custom of Jameson, who was justly regarded at that time as the apostle of exact mineralogical knowledge in this country, to take his class to Salisbury Crags and there to inveigh in no measured terms against the infatuation of geologists in maintaining the igneous origin of those masses of basalt. Under such circumstances as these it is not surprising to find that geologists, judging the tree by its fruits, were led to conclude that from Mineralogy there was little to be hoped for in the way of assistance to their own science, and nothing at all to be feared in the way of criticism.

Although this state of estrangement between Geology and Mineralogy has now happily passed away, since the causes which brought it about have disappeared, it may still be doubted whether all the cultivators of these two sciences fully realize their mutual dependence, or clearly recognize their capabilities for mutual assistance. It may not be unprofitable, therefore, to inquire how perfect cooperation between mineralogists and geologists may best be promoted, and to reconnoitre those promising fields of research through which their joint advance must be made.

The realm of Nature has been recognized from time immemorial as consisting of three kingdoms: dealing with the affairs of these three kingdoms, respectively, there have grown up side by side three departments of natural knowledge—Zoology, Botany, and Mineralogy. But in recent years new and, I cannot help thinking, regrettable relations have sprung up between these sister sciences. Zoology and Botany, having developed a method, a classification, and a nomenclature, based on common principles, have been drawn together by bonds so close and firm that many regard them as indissolubly one—the science of Biology. Mineralogy, thus isolated, has been driven to seek new and unnatural alliances,—with Chemistry, with Physics, or with the Mathematical Sciences. For my own part I confess that I regard this threatened “Repeal of the Union” of the natural sciences as alike a misfortune and a mistake.

It is sometimes assumed that the objects dealt with by Zoology and Botany are so different in their essential characters from those treated of by Mineralogy, that the science of “Organic” nature must always follow a different path from that pursued by the science of “Inorganic” nature. The structures commonly known as *organic*, and the processes usually called *vital*, are asserted to be so entirely different, alike in their origin and in their essence, from anything existing in the Mineral kingdom, as to warrant the establishment and perpetuation of a fundamental distinction between the sciences dealing with “living” and “non-living” matter respectively.

In the year 1854 a very acute thinker, who at one time occupied this Chair, made a serious attempt to formulate the distinctions which are supposed to divide living from non-living matter; but at a subsequent date, admitting with characteristic candour that he had altogether outgrown these ideas, Professor Huxley argued, with great skill and cogency, that “vitality” is merely a general term for a set of purely physical processes, differing only in their complexity from those to which “inorganic” matter is subject.

It is a circumstance of no small significance that no definition of *life* which has yet been proposed will exclude the kind of processes which we can now show to be continually going on in mineral bodies. “Life,” said the late George Henry Lewes, “is a series of definite and successive changes, both of structure and composition, which take place in an individual without changing its identity.” Mr. Herbert Spencer prefers to define life as “the definite combination of heterogeneous changes, both simultaneous and successive, in correspondence with external co-existences and sequences.”

If either or both of these definitions of life be accepted as satisfactory, then, as I hope to demonstrate to you, the minerals which build up the crust of our globe unquestionably "live." At all events I am confident of being able to show that "in correspondence with external co-existences and sequences," or, in other words, as the conditions to which they are subjected vary, they undergo "a series of definite and successive changes, both in structure and composition, without losing their identity."

It may seem paradoxical, but it is nevertheless true, that the "vitality" of minerals—I really do not know what other term to use to convey my meaning—is much greater than that of plants, and, *a fortiori*, than that of animals; and this is the direct and necessary consequence of their less complex and more stable chemical constitution.

The Zoologist regards as a case of remarkable vitality the recovery of snails which had been long affixed to a museum-tablet, upon their immersion in warm water. The Botanist cites the germination of seeds taken from ancient Egyptian tombs as a striking illustration of how long life may remain dormant in the vegetable world. Let us now turn to the Mineral kingdom. A quartz-crystal develops to certain dimensions, in accordance with the natural laws of its being, and when the necessary conditions of growth cease to environ it, its increase is arrested. But the crystal still retains its "vitality," that is the power of further development which is dependent on its particular "organization" or molecular structure. We may destroy that "organization" and the "vitality" which is dependent upon it in a single instant, by subjecting the crystal to the action of hydrofluoric acid or of an oxyhydrogen flame. But unless its "organization" and "vitality" be thus brutally stamped out, the crystal and, indeed, every fragment of it retains, not the "promise" only, but the very "potency of life." It may be worn by wind and wave into a rounded and polished sand-grain; it may be washed from the beds of one formation, to form part of the materials of a new one, and this process may be repeated again and again; but after countless wanderings and unnumbered "accidents by flood and field," extending over millions on millions of years, let but the necessary conditions of growth again environ it, and the battered and worn fragment will redevelop, in all their exquisite symmetry, its polished facets, it will assume once more the form of a quartz-crystal, having at least as much claim to *identity* with the original one, as a man has with the baby from which he has grown.

“Life!” “Vitality!” These terms are but convenient cloaks of our ignorance of the somewhat complicated series of purely physical processes going on within plants and animals. “Organization!” Why should the term be applied to the molecular structure of an *Amœba* or a yeast-cell, and refused to that of a crystal? And even if we choose to maintain such distinctions as these, must we also insist that they constitute a basis sufficiently broad upon which to establish our classification of the sciences?

Unquestionably there are differences between the changes which take place in these wonderful cycles in animals, plants, and minerals respectively. As animals differ from plants in not being able to build up their tissues from the simple compounds of the mineral kingdom, so animals and plants alike differ from minerals in their power of growth by intussusception.

But perhaps the most striking difference of all between the “vital” processes in animals, plants, and minerals is found in the *rate* at which they take place. Animals, in consequence of the instability of their chemical constitution, are distinguished by an almost ceaseless activity and a consequent brevity of existence. Plants, in the slower rate at which their vital processes take place, bridge over to some extent the tremendous gap between animals and minerals. In these last the vital processes are so prolonged in their manifestations, owing to the stability of their chemical composition, and they are not unfrequently interrupted by such enormous intervals of time, that they can only be recognized by the geologist.

The changes which take place in an ephemera are rapid indeed as compared with those going on in the oak-tree among the branches of which it may spend its brief existence; but in the rocks among which the oak thrusts its rootlets, other processes are going on compared with which the life of the oak-tree is as “fast” as that of the ephemera compared with its own.

Nevertheless the three forms of “life” seem to start pretty much on a level. A solution of nitre in which crystallites are uniting, in obedience to the laws of “polarity,” to build up crystals with their regular forms, their molecular structure, and their powers of further development; a solution of sugar in which the cell of a yeast-plant is living and growing; and a third liquid with suspended vegetable particles in which an *Amœba* is increasing and multiplying,—these three may surely be compared with one another, however unlike may appear to be the higher developments in the three kingdoms to which they respectively belong.

I do not, of course, for one moment wish to suggest that it is practicable, or even desirable, to attempt an extension of the conventional use of the terms "life" and "organization." But I do think that it is of the first importance that we should clearly recognize the fact that the distinctions between living and non-living matter are not essential and fundamental ones, that cycles of change exactly similar in almost every respect to those occurring in the animal and vegetable kingdoms are equally characteristic of the mineral kingdom—though in the latter they are more difficult to follow on account of the extreme slowness with which they take place.

When this great truth is fully recognized, the separation of the Biological and the Mineralogical Sciences will be at an end, and Mineralogy will begin to profit by that revolution in thought and in method which has already done so much for her sister sciences.

The temporary divorce between Biology and Mineralogy has arisen, not from any inherent differences between their aims, their methods, or the objects of which they treat, but from the circumstance that while the former has in the last half-century advanced with the stride of a giant, the latter has during the same period tottered on with the feeble steps of infancy. Mineralogy is still in the "pupa stage" of its development; it is a classificatory science, with its methods imperfect, its taxonomy undeveloped, and its very notation undefined. Its cultivators, absorbed in the Sisyphean task of establishing new species and varieties, too often treat their science, with all its glorious possibilities, as though it were but akin to postage-stamp lore!

How is it, we may profitably ask, that the Biological sciences have made such prodigious advances, while the Mineralogical ones have lagged so far behind? We must ascribe the result, I believe, to two causes:—

In the first place, improvements in the construction of the microscope, and more especially the perfecting of methods of study by means of thin sections, have immeasurably enlarged the biologist's field of observation; Histology and the cell-theory, Embryology with all its suggestiveness, and many important branches of Physiological research, must have languished, if, indeed, they ever saw the light, but for the aid afforded by the microscopical methods of inquiry.

In the second place, the growth of Geological and Palæontological knowledge has been the leading factor in that profound revolution in Biological ideas which, sweeping before it the superstition of fixity

of species, has endowed this branch of natural science with the transforming conception of Evolution.

Now these two causes which have done so much for Biology are already working out the regeneration of Mineralogy; and I doubt not that in due time the fruits brought forth by the latter science will be equally satisfactory with those of the former.

The application of the microscope to the study of minerals has proved less easy than in the case of animal and vegetable structures. More than a century ago, it is true, several French geologists employed the method of crushing a rock, and of picking out from its powder the several minerals of which it was composed, for microscopic study; and in 1816, Cordier endeavoured, by systematizing the methods followed by his predecessors, Daubenton, Dolomieu, Fleurian, and others, to elaborate a scheme for the mineralogical analysis of rocks by the aid of the microscope. In recent years the French geologists, with MM. Fouqué and Michel Lévy at their head, have shown how, by the employment of the electro-magnet, of fluids of high density, and of various chemical reagents, this work of isolating the several minerals of a rock for microscopic study or chemical analysis may be greatly facilitated.

But the great drawback to this method of microscopic study of rocks, as devised in France, was found in the circumstance that it began by destroying the rock as a whole, and hopelessly obliterating the relations of its mineralogical constituents. Delesse and other observers, it is true, succeeded in obviating this difficulty, to some extent, by studying the structure of rocks as seen in polished surfaces under the microscope by reflected light.

The greatest step in advance in connexion with the microscopic study of rocks was undoubtedly made, however, when it was shown that transparent sections of minerals, rocks, and fossils can be prepared, comparable to those so constantly employed by biologists in their researches. William Nicol, of Edinburgh, was the first to discover, in the year 1827, how the mechanical difficulties in the way of the preparation of such sections could be surmounted; while Mr. Sorby, in a memorable communication to this Society, in 1858, showed us the first-fruits of the wonderful harvest of results to be obtained by the employment of this method.

But if the birthplace of the one method of microscopic study of rocks was France, and of the other Britain, it must be confessed that a large part of the merit of developing and improving these methods of inquiry is due to the Germans. To the labours of the

numerous, patient, and accurate students in that country must be ascribed much of the perfection to which the methods of microscopic mineralogy have now attained; though we must not forget in this connexion many most valuable contributions to the study from Scandinavia, Holland, Italy, and the United States.

As in the case of Biology, the results attained by the geologist have been the means of awakening new interests and inspiring a new philosophy, so in the case of Mineralogy, other problems have been suggested and entirely fresh conceptions of the scope of the science have followed from the development of geological thought. We are thus led to regard minerals, not simply as a set of curious illustrations of mathematical and chemical laws, but as important factors in the evolution of the globe. Mineral collections in the past have resembled greenhouses, wherein only beautiful, though often abnormal, growths are admitted; but in the future they will be like the herbaria of the botanists, where mere beauties of form and colouring are subordinated to the illustration of natural relationships and to the elucidation of the great problems of origin and development. Far be it from me to undervalue those wonderful crystals, the choice flowers of the mineral kingdom, which adorn our museums; but as there are many plants of extreme scientific interest which happen to possess only inconspicuous flowers, so there are not a few microscopic minerals, the study of which may lead us to the recognition of some of the most important laws of the mineral world.

I believe that what Geology has already done for Biology she is now accomplishing for Mineralogy; it may, indeed, be instructive to point out how, in every one of its departments, the employment of microscopic methods and the suggestion of new lines of thought are causing Mineralogy to develop in just the same directions that Biology has already taken before her. In this way we may perhaps best convince ourselves that Mineralogy is once more asserting her true position in the family of the natural sciences.

Every Natural-History science presents us with four distinct classes of problems. With respect to the objects of our study, we may make inquiries concerning their forms, their actions, their relations, and their origin. The answers to the first class of questions constitute *Morphology*, to the second *Physiology*, to the third *Chorology* or *Distribution*, and to the fourth *Ætiology*. The great problems of the mineral world, as I shall proceed to show, fall under precisely the same categories; and we may perhaps gather some useful hints

by a comparison between the immature results of the Mineralogist in each of these departments and those more perfect ones which have been attained by the Botanist and Zoologist.

The Morphology of minerals was for a long time studied to the exclusion of all other branches of the science; for the problems connected with form and structure were those which naturally first attracted the students of the "inorganic" world.

Few generalizations of science are so beautiful, and at the same time so suggestive, as those which have been arrived at by a discussion of the accurate measurements of crystal-angles. The constancy, within certain narrow limits, of corresponding angles, amid the almost infinite diversity of form assumed by crystals of the same mineral, is not less striking than the simplicity of the mathematical laws by which all these varied forms can be shown to be related to one another.

The actual forms assumed by crystals are often seen to be the result of a struggle between opposing tendencies in the molecules to build up diverse forms. In the growth of a quartz-crystal, for example, the tendency towards the termination of the crystal, by the formation of two rhombohedra, is being continually overcome by the opposing tendency towards growth in the direction of the prism-faces; nevertheless the marks of this struggle are manifested in the well-known striæ on the prism-faces, each of which indicates the temporary ascendancy of the rhombohedral over the prismatic bias. The tendencies towards the formation of the two rhombohedra are in turn seldom equal or able equally to assert themselves, and from this cause their unequal development results. In addition to these tendencies, others towards the formation of tetartohedral or other faces may come into play, and the almost infinite variety of forms which may thus be produced is well known to every Mineralogist.

But the study of the Morphology of minerals, which cannot be carried beyond a certain point by the aid of the goniometer, is capable of being pushed infinitely further when we investigate the internal structure of their crystals, as illustrated by their optical and other physical properties. Not only do we find the minutest details of their external form to be correlated with peculiarities of molecular structure, as revealed by their action on a beam of polarized light, but delicate differences in internal organization which the goniometer is powerless to detect become clearly manifested under

the searching tests of optical analysis. For the Mineralogist, indeed, the polariscope with its accessories has supplemented the goniometer, in the same way that the spectroscope has the balance of the Chemist.

What has been stated concerning the optical characters of minerals is equally true of their other physical properties; for the researches of recent years have shown all these properties to be intimately related to the symmetry of the crystal in which they are displayed. In every crystal, the faces of each group bearing the same relations to its axes exhibit characteristic peculiarities in their lustre, in their hardness, and in the manner in which they are acted upon by solvents; and these serve to distinguish such groups of faces from others in the same crystal having different relations to its axes. The elasticity of crystals, their power of conducting heat and electricity, and their phosphorescent, electric, or magnetic properties, whether natural or induced, are all manifested in varying degrees along certain directions which can be shown to be related to the particular symmetry of the crystal.

The more carefully we study both the forms and the physical properties of minerals, the more are we impressed by the conviction that the most intimate relations exist between these characters and the chemical composition of the minerals. The phenomenon of "plesiomorphism," as Miller proposed to call it, that is the slight variation in the angular measurements of crystals in the same species or group, when any of the constituents are replaced by vicarious or isomorphous representatives, very strikingly illustrates this conclusion. And the exact study of the optical properties of minerals shows that the slightest variation in the relative proportions of these vicarious constituents makes its influence felt by changes in their colour, in their pleochroism, in the nature and amount of their double refraction, in the position of their optic axes, and, indeed, in the whole assemblage of the properties of the crystal.

To the admirable investigations of Tschermak on the feldspars, the amphiboles and pyroxenes, the micas, and other groups of minerals we are largely indebted for the establishment of this conclusion; while Doelter, Max Schuster, and other mineralogists have contributed many striking observations which serve to extend and fortify it.

The application of the microscope to the study of the internal structure of minerals—their Histology—has led to the recognition of many beautiful and unsuspected phenomena. Studied in this way, the seemingly homogeneous masses exhibit many interesting inter-

growths and enclosures ; and the study of these, as shown by Sorby, Vogelsang, Renard, and Noel Hartley, may serve to throw new and important light upon the conditions under which the crystals were originally developed. Cavities containing carbonic acid and other liquids, with bubbles in constant and, seemingly, spontaneous movement, serve to awaken the interest of the naturalist not less powerfully than the mysterious creeping of protoplasm in the hair of a nettle, or the dance of blood-corpuscles in the foot of a frog !

Others among these histological peculiarities of crystals must be regarded as having a pathological significance : they are abnormal developments resulting from unfavourable conditions to which the crystals may have been subjected during their growth, or in the course of their long and checkered existence.

The variability exhibited in crystals of the same mineral is sometimes very startling. In addition to the varieties due to the combinations of many different forms, or to the excessive development of certain faces at the expense of others, we have the complicated and diversified structures built up by twinning according to different laws. Again, by oscillatory tendencies in the same crystal towards the assumption of different forms, or by the existence of causes calculated to interfere with the free action of the crystallizing forces, we may obtain varieties with curiously striated or curved faces. Not unfrequently large quantities of extraneous materials, solid, liquid, or gaseous, may be caught up in the crystal during its growth, and these foreign substances may be so far affected by the polar forces operating around them as to be made to assume definite and symmetrical positions within the crystal.

Even in the case of minerals of identical chemical composition and similar crystalline form, marked variations in physical properties may result from differences in the conditions under which they have originated. In lustre, density, and other characters, Adularia differs from Sanidine, and Elæolite from Nepheline. Dr. Arthur Becker has shown that Quartz exhibits marked variations in its specific gravity, according to the particular conditions under which it has been formed.

There is one kind of morphological variability in minerals which has during recent years attracted a great amount of attention, and excited much discussion among Mineralogists. Soon after his memorable discovery of the relations between the crystalline forms of minerals and their optical properties, Brewster detected certain apparent exceptions to his important generalization ; and since his day

many additions to these curious anomalies in the optical behaviour of minerals have been made by other observers. So greatly, indeed, have these been multiplied in recent years, that it is doubtful if any mineral crystallizing in the Cubic, the Tetragonal, or the Hexagonal system could be cited in which the optical properties are precisely what they ought to be according to theory; and similar anomalies are also found in crystals possessing lower degrees of symmetry.

The attempts which have been made by some crystallographers to account for these optical anomalies in crystals, by assuming that they possess only a pseudosymmetry, the result of very complicated twinning, ingenious as they undoubtedly are, remind one of the wonderful addition of eccentrics and epicycles by which astronomers so long sought to maintain the credit of the Ptolemaic theory. But as in the latter case complexities and difficulties alike vanished when the centre of the system was shifted from the earth to the sun, so have the discoveries of Klein and Rosenbusch removed the necessity for the painfully elaborate crystallographic hypotheses to which I have referred.

Most mineralogists will now be prepared to admit, as the result of these researches, that the perfection alike of form and of optical properties which may characterize a crystal when first formed, is liable to slight modification, as the conditions of temperature and pressure under which it exists vary. In consequence of this, almost all natural crystals are found, when we study them with sufficient care, to exhibit slight but very striking and significant differences in form and optical behaviour from what they ought theoretically to possess.

While our knowledge of the ordinary mineral varieties promises to be vastly extended by the improvements which have been made in the methods of optical and chemical diagnosis under the microscope, there is nevertheless, at the same time, reason to hope that the relationship of these numerous varieties will, by the same means, be made more distinctly apparent. As the existence of well-defined natural groups of minerals becomes more clearly established, through the study of interesting though inconspicuous links, we shall obtain a basis for a much-needed reform in Mineral Taxonomy and Nomenclature.

The more carefully we pursue our researches among the diversified forms of the mineral world, the more are we impressed by the conviction that each mineral, like each plant or animal, possesses its own individuality. Nature does not make *facsimiles* in the

mineral, any more than in the vegetable or the animal kingdoms. All the sciences of nature must be content to recognize individuals as the only real entities, and to accept species, like genera, families, and orders, as convenient but purely artificial conceptions.

The geological study of minerals leads us to regard each specimen that we examine as possessing a distinguishing combination of properties, some of which are impressed upon it by causes operating when it came into being, while others are no less clearly the result of the long series of vicissitudes through which it has since passed.

Of all the branches of Mineral Morphology there is none from the study of which the geologist has gained more in the past, or from which he has greater reason to look for future aid, than that of the Embryology of crystals.

In the year 1840 Link showed that the first step in the formation of crystals in a solution consists in the separation of minute spherules of supersaturated liquid in the mass: and subsequently Harting in Holland, and Rainey and Ord in this country, obtained a number of interesting experimental results, by allowing crystallization to take place slowly in mixtures of crystalloids and colloids.

Valuable contributions to the same subject were made by Frankheim, Leydolt, and others: but it is to Hermann Vogelsang that we owe the greatest and most important contributions to Mineral Embryology. By the ingenious device of adding viscous substances to solutions in which crystallization was going on, he succeeded in so far retarding the rate at which the operation took place, as to be able to study its several stages. He thus showed how the minute "globulites" gathering themselves into nebulous masses, or ranging themselves according to mathematical laws, gradually build up skeleton-crystals, by the clothing of which the perfect structures arise.

Since the early and regretted death of Vogelsang, the subject of the development of crystals from their embryos, the so-called *crystallites*, has been successfully prosecuted by Behrens, Otto Lehmann, Wichmann, and other investigators.

Now in all glasses—whether of natural or artificial origin—in which the process of primary devitrification is going on, we have examples of the growth of crystals in a viscous and retarding mass, and in these, as Leydolt, Zirkel, and Vogelsang clearly saw, admirable opportunities are afforded to us for studying the formation of crystallites, and the laws which govern the union and growth of these into crystals. Two years ago, my predecessor in this Chair

submitted to you the interesting results of his own researches upon the devitrification of artificial glasses and slags; and the subject has since been pursued by Velain in France, and by Hermann and Rutley in this country.

The igneous rocks supply us with admirable opportunities for studying Mineral Embryology. In the same rock-mass we may sometimes find every possible gradation, from an almost perfect glass to a holocrystalline aggregate. By the study with the microscope of the several transitions in different parts of the mass, we obtain data for the most important conclusions concerning the phenomena of crystal-development.

There is another line of research in connexion with Mineral-Embryology, which appears to be full of promise, and which has not yet received all the attention it deserves. In the "contact-zones" around great igneous intrusions, we find the curious so-called "spotted slates," which under the microscope are seen to contain nebulous patches, the mere ghostly presentments of crystals, struggling into being in the amorphous mass. The development of these nebulous masses into perfect crystals, exhibiting the characteristic external forms and optical properties of andalusite and cyanite, of garnet and epidote, of hornblende and mica, may be traced in some cases with the greatest facility.

More complicated still are the phenomena exhibited along the foliation-planes of the rocks, which have been made to flow in the act of mountain-making. There, as the old minerals are destroyed, new ones build themselves up from their elements. The study of all the steps of this process is an undoubtedly difficult one; but the results already obtained by Reusch, Lossen, Heim, and Lehmann, by Lapworth, Teall, Roland Irving, and Williams, lead us to look hopefully forward to the full solution of the grand but complicated problems of regional metamorphism.

The field of Mineral-Embryology is indeed a promising one, and its diligent cultivators may hope to gather a harvest no less rich than that which has been reaped by the workers in the same department of the Biological Sciences.

Let us now turn from the statical aspect of minerals, their Morphology, to the dynamical aspects, their Physiology.

Minerals are not fixed and unchangeable entities, as they are sometimes considered. On the contrary, they exhibit varying degrees of instability, and pass through very definite series of metamorphoses.

We have already seen that every alteration in the temperature or other conditions which surround a crystal leads to striking modifications of molecular structure, which are at once revealed by the delicate tests of optical analysis. So sensitive, indeed, are some crystals to the action of external forces, that even the passage of the light-waves through their substance leads to permanent molecular rearrangements which are evidenced by marked changes in colour, translucency, and other properties.

Many minerals have their atoms so arranged that the action of external forces causes them to fall readily into new combinations. In this way we have brought about such paramorphic changes as that of aragonite into calcite, and augite into hornblende. Excessively slight manifestations of force are sometimes sufficient to induce these paramorphic changes.

But the most significant fact of all is that every crystal possesses certain peculiarities of molecular structure, and as the result of this internal "organization" it responds in a definite manner to the action of various external forces, undergoing in this way well-marked series of physical and chemical changes without losing its identity. As the final result of such successive changes, however, the bonds which hold the "organized" structures together are gradually weakened, and at last break down altogether. In this way the separate existence of the mineral comes to an end; but the materials of which it was composed, resolving themselves into new compounds, may go to build up the substance of other "organized" structures. Need I point out that in all these respects minerals behave exactly like plants and animals?

But in the case of plants and animals changes such as these, which are the direct outcome of external forces acting on a special organization, are called *Physiological*, and I know of no valid reason why the same term should not be employed in the case of minerals. It is true that the accomplishment of the cycles of change in minerals often requires periods of time of enormous duration, and that during incalculable intervals they may appear to be wholly suspended; but in these respects the "life" of a mineral differs from that of a plant in just the same manner as the latter does from the life of an animal.

I must ask your attention for a few moments to these peculiarities of internal organization in minerals, and to the way in which the various physical and chemical forces act and react upon them in consequence of their special organization.

Recent researches have shown that every crystal possesses a number of planes, all of which are related to its peculiar symmetry, along which the several physical forces operate in a marked manner to produce changes in the physical and chemical properties of the crystal. These planes have been called the "structure-planes" of the crystal.

By far the most obvious of these structure-planes of crystals are those of cleavage. When crystals are subjected to the action of mechanical force they break up along one, two, or three definite planes, with varying degrees of ease. In some cases when this separation cannot be readily effected by percussion or pressure, it may be brought about by the unequal expansion and contraction in a crystal resulting from alternate heating and cooling. We cannot arrive at the limit of this liability of a crystal to separate along its cleavage-planes; if we powder a calcite-crystal and examine the fine dust under a microscope, each minute grain will be seen to have the form of a cleavage-rhomb!

Now the exquisite molecular structure of a crystal, of which this wonderful property of cleavage is the outcome, is borne witness to, not only by the perfection of the cleavage-surfaces—presenting, as they do, a lustre which no artificial polish can imitate—but by the fact that each particular set of cleavage-surfaces presents definite characteristics, analogous to those seen in the actual faces of crystals. Each exhibits striking peculiarities in its mode of reflecting light; each yields in varying degrees to a hard point drawn across it in different directions; and each, when treated with appropriate solvents, is attacked in a characteristic fashion, giving rise to the geometrical forms known as the etched-figures. Wonderful as these cleavage-surfaces are, however, it must be remembered that the power of cleavage is one that, under ordinary circumstances, remains altogether *latent* in crystals.

Cleavage-planes, however, are not the only latent structure-planes in crystals. Long ago it was shown by Brewster, Reusch, and Pfaff that when minerals are subjected to pressure in certain directions, their molecules appear to glide over one another along certain definite planes within the crystal; and if we examine optically a crystal which has been treated in this manner, it is actually found to exhibit a series of twin-lamellæ arranged parallel to the so-called "gliding-planes." It thus appears that in the movements set up within a crystal by the application of force from without, certain of the molecules of which the crystal is built up, lying in bands

parallel to the gliding-plane, are actually made to rotate through an angle of 180° .

At one time these "gliding-planes" were regarded as being peculiar to a few minerals, such as calcite and rock-salt; but the investigations of Frankenheim, Baumhauer, Foerstner, and especially of Mügge, have shown that they exist in crystals belonging to every group in the mineral kingdom, including all those minerals which occur as common rock-forming constituents, such as the feldspars and pyroxenes.

As is the case with the cleavage-planes, so with the gliding-planes, there may exist one, two, or three in the same crystal. One of these is usually a principal gliding-plane—the slipping movement with its accompanying twin-lamellæ being produced parallel to it with the greatest facility—while the others are subordinate ones.

Strange to say, however, the particular gliding-plane along which a crystal yields appears to be determined, not only by the direction in which the force is applied, but to some extent also by the nature of that force, whether percussive, or a sustained pressure, or a violent stress; in some cases where the application of external force fails to produce the gliding movement with its accompanying lamellar twinning, it may be induced by the strains which result from unequal expansion and contraction during the heating and cooling of a crystal. Some mineralogists have, indeed, proposed to apply distinctive names to the results which follow from the application of different kinds of force—whether a blow (*Schlagfiguren*), pressure (*Reissflächen*), or the effect of heating and cooling (*Contractionsrisse*).

The gliding-planes of crystals are quite distinct from the cleavage-planes, though some very curious and interesting relations have, in certain cases, been shown to exist between them. That the artificial formation of twin-lamellæ, like the production of cleavage, is rendered possible by complicated molecular structures, it is scarcely necessary to point out. The application of external force to such crystals is like the putting of a spark to a train of gunpowder; the molecules lying in parallel bands are in unstable equilibrium, ready, so soon as set in motion, to roll through an angle of 180° .

There is still a third and even more subtle set of structure-planes in crystals to which I must now allude, those, namely, for which the name of *solution-planes* has been proposed.

It was long ago shown by Daniell that when crystals are exposed

to the action of solvents, they are attacked in such a manner as to give rise to peculiar geometrical forms. The subject has been followed up by Baumhauer, Leydolt, Becke, and others, who have shown what a wonderful variety of "etched-figures" may be produced by operating upon the various faces and cleavage-surfaces of different crystals.

Quite recently, however, it has been shown by Von Ebner, as the result of his studies of calcite and aragonite, that all the complicated phenomena of the etched-figures arise from the existence of planes along which solvent or chemical action takes place most readily within a crystal. It thus appears that these complicated etched figures, with their curved and striated surfaces, are indications of the combination or oscillation of tendencies to chemical action along the different solvent-planes of the crystal.

My own experiments have enabled me to show that the chemical action taking place along the solution-planes of crystals leads to the development of cavities, often assuming the forms of negative crystals, which may become wholly or partially filled with the products of the chemical action.

Although the solution-planes are quite distinct, both from the gliding-planes and the cleavage-planes of crystals, I have been able to show that some curious [and interesting] relations exist between them. If lamellar twinning has been already developed in a crystal, then chemical action takes place along the gliding-planes in preference to the normal solution-planes.

It is only when we study the minerals building up the rock-masses of the globe that we fully realize the importance of these molecular structures, and the wonderful changes which crystals are capable of undergoing, as a consequence of their internal "organization." Then, and then only, do we begin to understand the significance and the far-reaching consequences of the *physiological* changes of which minerals are susceptible.

The crystals forming the rock-masses of the globe have been subjected to every variety of mechanical force—violent fracture, long-continued strain, steady but enormous pressure—prolonged over vast intervals of time, to which must be added the potent effects of alternate heating and cooling. Such crystals, moreover, are transfused through their whole substance by various liquids and gases acting under tremendous, and sometimes varying, pressures.

Under such circumstances it is not surprising to find that the crystals have often yielded along their cleavage-planes, and that

cleavage-cracks have been produced. These, by affording a ready channel for the passage of solvents, not unfrequently determine the course of various chemical operations going on within the crystal.

Not unfrequently, too, the rock-forming minerals have yielded along their gliding-planes, and the development in them of twin-lamellæ is the result. Every crystal of calcite in an ordinary metamorphic limestone, and many of the plagioclase feldspars in igneous rocks, exhibit the secondary lamellar twinning which has arisen from the action of mechanical forces upon the mass*. The microcline structure in orthoclases, with many other similar structures in other minerals, must almost certainly be ascribed to the same cause.

Still more remarkable are the consequences which follow from the existence of the solution-planes in crystals. By the action of various solvents under pressure, augite is made to assume the forms known as diallage and pseudo-hypersthene, and feriferous enstatite of bronzite or hypersthene, while the feldspars acquire their avanturine, schiller, and chatoyant phenomena. When, in addition to the statical pressures due to thousands of feet of superincumbent rocks, these solvent agencies work with those tremendous dynamical aids afforded by deforming stresses, such as make the rocks to flow during mountain-making, it is not surprising to find the molecules of the original crystals breaking from their old allegiances, and the liberated atoms uniting to form new minerals, the position of which is determined by the lines of flow in the mass.

Not a few of our gems owe their exquisite beauty to these

* It has often been asserted that the "striation" on the faces or cleavage-surfaces of crystals is an indication of the existence of polysynthetic twinning. In the oligoclase of Ytterby and other localities, however, I have found that many crystals which exhibit striation do not affect polarized light differently in the alternate striæ; but on submitting the crystals to alternate heating and cooling, and sometimes by percussive force, the twinning may be easily developed in them. It appears from these observations that the crystals are built up of lamellæ, in which the molecules are alternately in stable and unstable equilibrium. I have in some cases found that the stresses upon a slice of feldspar which is being heated and cooled and then ground into a thin section, while cemented to a glass plate during the preparation of a microscopic slide, are sufficient to cause the rotation of the molecules in the alternate lamellæ. In some cases, I have no doubt that twin-lamellation, like cleavage-cracks, may be induced in the crystals of our rock-sections during the processes to which they are submitted in their preparation.

physiological changes which have taken place in them since their first formation. The ardent glow of the Sunstone and the pale watery gleam of the Moonstone, no less than the lovely play of azure tints in Labrador-spar and the bronzy sheen of Paulite, are the result of physiological processes taking place in crystals which were originally clear and translucent. In the profound laboratories of our earth's crust slow physical and chemical operations, resulting from the interaction between the crystal, with its wonderful molecular structure, and the external agencies which environ it, have given rise to new structures, too minute, it may be, to be traced by our microscopes, but capable of so playing with the light-waves as to startle us with new beauties, and to add another to

“The fairy tales of science, and the long results of time.”

Yes! minerals all have a *life-history*, one which is in part determined by their original constitution, and in part by the long series of slowly varying conditions to which they have since been subjected. In spite of the circumstance that their cycles of change have extended over periods measured by millions of years, the nature of their metamorphoses and the processes by which these have been brought about are, in all essential respects, analogous to those which take place in a *Sequoia* or a butterfly. In spite, too, of the limitations placed upon us by our brief existence on the globe, it is ours to follow in all its complicated sequence this procession of events, to discover the delicate organization in which they originate, to determine the varied conditions by which they have been controlled, and to assign to each of them the part which it has played in the wonderful history of our globe during the countless ages of the past.

The subject of Distribution, or Chorology, is one of no less importance in the study of the mineral than in that of the vegetable and animal kingdoms. The relations of minerals to one another, and the manner in which they make their appearance in respect both to time and place, constitute a most instructive and suggestive field of research.

The older mineralogists paid some attention to the question of the mode of association of minerals with one another, which they described under the term “Paragenesis.” But this was at a time when only large and freely crystallized specimens received much attention. At the present day this question of the varied distri-

bution of minerals in space and time, and the manner in which they are associated with one another to build up rock-masses, constitutes a most important branch of our science, that to which the name of Petrology is given.

Under the name of "Petrography" an attempt has been made to establish a branch of Natural-History science which shall bear the same relation to Mineralogy as that science does to Chemistry. As minerals are formed by the union of certain chemical compounds, so rocks, it is argued, may be regarded as being built up of different minerals. But it must be remembered that while minerals possess a distinct individuality—the result of their different chemical constitution and their characteristic crystallographic form—we are quite unable to point to anything analogous to these in the case of rocks.

How is a rock- "species" to be defined? It is not enough to state its ultimate chemical composition; for rocks of the most varied character and origin may agree in this respect. Equally futile is it to take mineralogical constitution as the basis of our classification; for, in the same rock-mass, the species of minerals which are present and their proportions to one another may, and, indeed, often do, vary from point to point. Nor does minute structure, though affording admirable criteria for distinguishing certain *types* of rock, supply a sufficiently definite means of diagnosis for all the different varieties which occur. A system of "lithology" may, indeed, be devised, if we confine our attention to the hand-specimens in our museums; but it breaks down the moment that we attempt to apply it in our researches in the field.

I have long felt assured that all attempts at a nomenclature and classification of rocks must, for the reasons just stated, be regarded as tentative and provisional only; but the careful study of rocks is nevertheless bringing to light a number of facts calculated to profoundly modify mineralogical no less than geological thought and speculation.

Petrology forms the link between Mineralogy and Geology, just as Palæontology does between Biology and Geology. Mineralogy has justly been styled the alphabet of Petrology; but if the orthography and etymology of the language of rocks lie in the province of the Mineralogist, its syntax and prosody belong to the realm of the Geologist. In that language, of which the letters are mineral species and the words are rock-types, I am persuaded that there is written for us the whole story of terrestrial evolution.

Petrology, it is clear, could make but little progress until the improvement of microscopic methods enabled us to make accurate determinations of the minerals in a rock, even when these are present as the most minute particles. The characteristic peculiarities of the different rock-forming minerals, so carefully studied by Zirkel, their accurate optical diagnosis, at which Rosenbusch has laboured with so much success, supplemented by the micro-chemical methods of Knop, Bořický, Streng, and Behrens, and the pyro-chemical method of Szabó, have already done much to render exact our methods of recognizing the minerals in a rock. The contrivances, for which we are principally indebted to the French petrographers, for effecting the isolation of the minerals in rocks, so that they may be submitted to accurate chemical analysis, enable us in cases of difficulty or doubt to confirm or check the results of our microscopic studies.

But there is at present perhaps a tendency to confound the end with the means in such researches as these. When all the varieties of minerals in a rock have been correctly identified, the work of the Petrologist is not ended; on the contrary, it is only just begun.

The relationship of the several minerals in a rock to one another the discrimination between such as are original and those of secondary origin, and the recognition among the former of the essential, as distinguished from those that are accessory or accidental,—these are problems of even greater importance than the exact determination of the species or varieties to which each belongs. In not a few rocks it can be demonstrated that every one of its present mineral constituents is different from those of which it was originally made up; in some cases, indeed, it may be shown that the recombination of the elements of the rock into fresh mineral aggregates has taken place again and again. As well might we try to give a rational account of our English speech without taking into account the series of changes through which it has passed in its evolution from the Anglo-Saxon dialects, as to explain the nature of a rock without studying the influence upon it of the forces by which it has gradually acquired its present characters.

With respect to the geographical distribution of the different mineral species, many suggestive observations have been made. Some, like the feldspars, the pyroxenes, and the olivines, appear to be ubiquitous in our earth's crust, and even make their appearance again in those bodies of extra-terrestrial origin—the meteorites. Others, like leucite, nepheline, hauyne, sodalite, and melilite, are

exceedingly abundant in certain areas of the earth's surface, while they appear to be wholly wanting in others.

Still more remarkable are the relations which are found to exist between the types of rocks occurring in different geographical areas. The study of this subject is leading us to the recognition of the fact that there are distinct petrological provinces. In closely adjoining areas—such as Hungary and Bohemia, for example—widely different types of rock have been erupted during the same geological period; and this is a fact not less striking and significant than that of the meeting of two perfectly distinct biological provinces along a line which traverses the Malayan archipelago. It cannot be doubted that the prosecution of this hopeful branch of study—the geographical distribution of minerals and rocks—will lead us to results of the highest interest and value.

That there will be shown to be a distribution of rocks in time, as well as in space, I am perfectly prepared to believe. I cannot but think, however, that some of the generalizations on this subject which have been hazarded are somewhat premature. To a geologist (especially one belonging to the school of Lyell) it is equally difficult to conceive that there should be a broad distinction between the metamorphic rocks of Archæan and post-Archæan age respectively, as that the pre-Tertiary volcanic rocks should be altogether different in character from those of Tertiary and Recent times.

The great object of all our studies (concerning the Morphology, the Physiology, and the Chorology) of the mineral kingdom ought to be to arrive at definite ideas concerning its *Ætiology*—the causes by which the existing forms, capabilities, and positions of minerals and rocks have been determined.

While the *fossils* contained in rock-masses afford us the means for determining the date of their origin, the careful study of the *minerals* which they include may enable us to unravel the complicated series of changes through which they have passed since their first formation.

Eighteen years ago, when endeavouring to show how the origin of a particular rock might be elucidated by a combination of studies in the field, in the chemical laboratory, and by the aid of the microscope, I ventured to offer to this Society some general remarks on this subject. As it has been my constant labour ever since that time to apply the principles then enunciated to the case of rocks of more complicated character and more recondite origin, I may

perhaps be forgiven for repeating the words I then used. Every rock since its first formation "has undergone and it still is undergoing a constant series of internal changes, the result of the action of different causes, as heat, pressure, solution, the play of many chemical affinities, and of crystallographic and other molecular forces, causes insignificant perhaps in themselves, but capable under the factor *time* of producing the most wonderful transformations. The geologist is called upon to unravel the complicated results, to pronounce what portion of the phenomena presented by a rock is due to the forces by which it was originally formed, and what must be referred to subsequent change; to discriminate the successive stages of the latter and to detect their various causes; in short to trace the history of a rock from its deposition to the present moment."

Dr. Wadsworth has well characterized the changes which take place in rock-masses as due to the tendency of unstable mineral combinations to pass into stable ones. It must be remembered, however, that stability is a relative term, and that the arrangement of molecules which is stable under one set of conditions, becomes unstable under another set. As by the internal movements and the external denudation of the earth's crust, the conditions under which rock-masses exist are undergoing slow but continual change, new adjustments of the molecular structure of the mineral elements of such rocks are at the same time necessitated and brought about.

In attempting to reason as to the *original* conditions under which a rock-mass must have been formed, it is of great importance to avoid those sources of error which exist in rocks that have undergone much secondary alteration. Such rocks abound in, though they are not necessarily confined to, the older geological formations; and it is among the younger and fresher rocks, therefore, that we may most hopefully seek the key to many petrological problems.

If, for example, we concentrate our attention upon the more recent and less altered igneous rocks, it becomes clear that the degree of crystallization displayed by them has depended on the slowness with which consolidation has taken place, and that this has in turn been determined by the depth from the surface at which they have been formed. In this way, by the study of igneous rock-masses in Scotland and in Hungary, I was able to show that there is a perfect gradation from highly crystalline rocks (granites, diorites, and gabbros) into the ordinary volcanic types (rhyolites, andesites, and basalts, respectively), and from the latter into the various kinds of volcanic glass. These conclusions have been confirmed by subsequent

investigations like those of Hague and Iddings in the Comstock region, and of Lotti in Elba. Further and more recent researches have enabled me to show that certain types of structure have been determined in rocks, according to the more or less perfect absence of all movement within them during their consolidation.

Very remarkable, indeed, are the internal changes which take place in rock-masses when they are submitted to those powerful stresses which result from the movements that occur during mountain-making.

It was long ago asserted by Scrope and Darwin that the solid rock-masses of the globe, under such conditions as these, must have actually *flowed*, like the viscous lavas of the rhyolitic series. They were even able to show that the separation and disposition of the crystalline elements in such lavas present the closest analogy with what is seen in the crystalline schists and gneisses of greatly disturbed areas.

Since these early and notable researches, which were principally based on the study of rocks in the field, aided only by the pocket-lens, three classes of investigations have served to deepen our insight into the methods by which the schistose and gneissose rocks must have been produced.

In the first place, the experiments of MM. Tresca and Daubrée have shown that solid matter under enormous pressure behaves like a viscous substance, its whole internal structure exhibiting evidence of the flowing movements to which it has been subjected.

In the second place, the studies of M. Spring have established the fact that both paramorphic change and direct chemical reaction may result from simple pressure. Thus the unstable monoclinic form of sulphur, by a pressure of 5000 atmospheres, is at ordinary temperatures instantly converted into the stable rhombic form, a transformation accompanied by change of density and of many other physical properties. Still more striking is the well-known case of the unstable, yellow, rhombic, mercuric-iodide, which, by simple rubbing with a hard substance, passes into its stable, red, tetragonal allomorph. It is instructive to notice that the same change in both instances appears to take place "spontaneously" after a sufficient interval of time; or, in other words, small variations in temperature, pressure, and other surrounding conditions are capable, if sufficient time be allowed, of bringing about the same result as more intense pressure applied suddenly. That the similar paramorphic change of pyroxene into hornblende, which is so frequently exem-

plified in the earth's crust, is sometimes the result of intense pressure, and at other times follows from the repeated slight alteration of conditions during long periods of time, we have, I believe, abundant evidence.

The experiments of M. Spring which prove that direct chemical reactions can result from the action of pressure, are, however, of even greater interest to the geologist. By submitting mixed powders to intense compression, he succeeded in producing metallic alloys and various binary compounds, and also in bringing about double decomposition between many salts. That similar reactions between the complicated silicates which form the minerals of rocks have resulted from the enormous pressures to which they have been subjected, we have the most ample proof. Thus in rocks where such pressure has just begun to act, such as the "flaser-gabbros," wherever the unstable olivine is in contact with the almost equally unstable anorthite, chemical reactions have been set up by the pressure, and these have resulted in the formation of zones of enstatite and anthophyllite, hornblende and biotite, which have been so well described by Torneböhm, Bonney, Adams, and Williams. Provided with the clue supplied by these results, we find little difficulty in going one step further. When the pressure has been still more intense, as in mountain-making movements, reactions are set up among all the minerals of the rock-mass, the elements of which it is composed, set free from their old engagements, enter into new alliances, and the result is the formation of a completely new set of crystallized minerals.

The third class of researches, destined, as I believe, to remove our difficulties in explaining the origin of the schistose and gneissose rocks, are those already alluded to as having been undertaken with the microscope. As yet the details of such changes have only been explained in the case of some of the simpler examples; but I am convinced that the persevering application of the same methods in the field and the laboratory will result in the removal of difficulties that now seem to be absolutely insuperable.

Some observers in this country have been led to infer that the recrystallization of rock-masses under pressure has in all cases been preceded by their pulverization. Of this, I confess that I can find no evidence. That near great faults of all kinds this reduction of rocks to powder does take place, we find abundant proof; but the evidence seems to me to also point to the conclusion that such *rock-crushing*, as distinct from *rock-flowing*, is in every case local and exceptional.

There is another and totally different series of changes which takes place in rocks, when, brought near to the surface by denudation, they are exposed to the action of water, oxygen, carbonic acid, and other atmospheric agents. The breaking-up of the alkaline silicates and the deposition of secondary silica, the formation of the zeolites, the epidotes, the chlorites, and the serpentines, the resolution of crystallized minerals into isotropic mixtures, and the recrystallization of these in new forms, all offer problems of the highest interest to the geologist.

I may venture, in drawing these remarks to a close, to indicate another point of analogy between the three Natural-History Sciences. It is found in the circumstance that experimental verifications of our conclusions are often difficult, if not actually impossible.

We must be content to reason from the proved variability of the existing forms of plants and animals as to the possibility of the production in time of new species. And in the same way, with our limited command of heat, pressure, and especially of time, we can scarcely hope to originate the exact counterparts of all the various minerals and rocks of our earth's crust.

We may nevertheless point with satisfaction to what, in spite of such difficulty, has already been accomplished in this interesting field of research. The honour of having pushed these researches to such successful issues belongs chiefly to the chemists, mineralogists, and geologists of France. To the labours of Senarmont, Daubrée, and a host of other workers we owe the artificial production of a very large number of the minerals of our globe; while the ingenious experiments of Fouqué and Michel Lévy have resulted in the formation of many rocks differing in no essential particulars from those which have been produced by natural agencies.

In the prosecution of his various researches the importance and value of exact Mineralogical knowledge to the Geologist is becoming every day more apparent. The temporary estrangement between the cultivators of Mineralogy and Geology is now happily and for ever at an end; very heartily, indeed, do geologists recognize and welcome the aid of their brethren the mineralogists.

But if it be confessed that the benefits, past and prospective, conferred on geological science by Mineralogy are vast and even incalculable, it must also be admitted that the debt is amply repaid by the beneficial influence which is being exercised in turn upon Mineralogy by Geology.

Some time ago a distinguished mineralogist asked me if I did not

find the ordinary text-books of his science but little calculated to arouse the interest or excite the enthusiasm of students. I am sure that the energy of my assent must at least have assured my friend of the strength of my convictions on the subject.

Too long, indeed, has the accumulated mass of mineral-lore recalled the grim vision of the seer of Chebar. In that gruesome valley the wail of the student, "The bones are very dry!" has been echoed by the sigh of the teacher, "Can these bones live?" But now from the four winds of heaven come the constructive ideas of many minds—from Scandinavia and from France, from Germany and from the United States—and in obedience to this influence behold "a great shaking" in the formless mass. Scattered facts, isolated observations, imperfect generalizations, and tentative hypotheses are falling together "bone to his bone," and are building up a sound body of mineralogical knowledge, into which, the spirit of geological thought entering, Mineralogy shall stand forth a living science!

February 23, 1887.

Prof. J. W. Judd, F.R.S., President, in the Chair.

Edward Bickerton Milward, Esq., Grube Wohlfahrt, Heilenthal, Eifel, Germany, was elected a Fellow of the Society.

The List of Donations to the Library was read.

The following communications were read:—

1. "On the Origin of dry Chalk Valleys and of Coombe Rock." By Clement Reid, Esq., F.G.S.

2. "Probable amount of former Glaciation of Norway, as demonstrated by the present condition of Rocks upon and near the western coast." By W. F. Stanley, Esq., F.G.S.

[Abstract.]

The observations on which this paper are based were made in June last, during a voyage along the west coast of Norway. Inland conditions were also noted in the Hardanger and Sogne Fjords, and a few trips up some of the valleys enabled these inland observations to be further extended. The Author limited his work to searching for outline evidence of ice-action. The aspect of the coast for hundreds of miles consecutively has a uniform character of jagged and pointed rocks nearly to the sea-level. At the mouths of the fjords the rocks are more rounded, particularly at heights less than 100 feet. Within the Arctic Circle the Swartisen glacier reaches nearly to the sea, and here the rocks are more rounded.

The Author exhibited sketches showing the characteristic forms of the rocks, and concluded from a study of these that ice had never prevailed along the entire western coast of Norway, neither had inland ice of any considerable thickness flowed over this coast in sufficient volume to wear off the points of the sharply fractured granite. Even the rocks below 100 feet are not more worn than is sometimes the case in tropical climates. The "shark's teeth" of the Lofotens have not been planed down, nor is there any vestige of the great ice-sheet of our text-books within the Arctic Circle upon the coast of Norway. Even in the fjords there is no evidence of ice-action until we arrive at the head, where it is very evident. There can be no better demonstration of the extent of former glaciation than in the Romsdal valley, where the line of the worn base extends as high up the rock as 600 feet 10 miles inland. He also instanced the principal glaciers of the Folge Fjord, now about 7 miles from the open water of the fjord, though formerly within half a mile. The angular character of

the low rocky island in front of Odde shows that it cannot have advanced further.

The Author concluded that at no period within geologically recent, say Tertiary times, has ice extended much further than at present. Seeing that the morainic matter now in the valleys has been derived from the hills, there must formerly have been a greater extent of land above the snow-line, and this would cause a former extension of glaciers without resort to any extraneous theory or change of climate. The Great Ice Age has left no trace on the Norwegian western littoral.

DISCUSSION.

Prof. GEIKIE said he had visited the country, and had come to precisely opposite conclusions to the writer. It appeared to him that from the outer islands up to the higher mountains the lower grounds have been buried under a thick sheet of ice. Occasionally the higher parts of the sides of fjords are weathered, and the marks of glaciation have disappeared, whilst these marks are still distinct at lower levels.

Mr. BLANFORD asked if Mr. Stanley had seen Christiania Fjord, and remarked that, as clear evidence of glaciation on a large scale was found in Southern Norway, the coast at a more northern latitude could scarcely have been free from ice-action.

Col. McMAHON remarked on the extent to which rocks are worn away and a rough surface given to rocks by severe frosts, as shown in the Himalayas.

Mr. STANLEY said the glaciation was peculiarly distinct in the heads of the valleys, where the granite has retained the polished surface left by the glaciers. The extraordinary fact was that rocks of grey granite close to the sea should be so sharp as they are if ice had gone over them, for instance the so-called "shark's teeth" of the Lofoten Islands. The fact that the Stor Fjord was deeper than the ocean between England and Norway was also opposed to the idea of ice having cut the valley.

The following specimens were exhibited:—

Specimens of Romsdal Gneiss, exhibited by W. F. Stanley, Esq., F.G.S., in illustration of his paper.

March 9, 1887.

Prof. J. W. JUDD, F.R.S., President, in the Chair.

William Barlow, Esq., Hillfield, Muswell Hill, N.; William Worby Beaumont, Esq., Memb.Inst.C.E., 229 Norwood Road, Herne Hill, S.E.; Martin William Browne Ffolkes, Esq., Assoc. Memb. Inst.C.E., 11 Delahay Street, Westminster; Samuel James Hawkins, Esq., 3 The Promenade, Highgate, N.; and Jonathan Coulthard Walton, Esq., Writhlington, near Bath, were elected Fellows of the Society.

The List of Donations to the Library was read.

The following communications were read:—

1. "On *Chondrosteus acipenseroides*, Ag." By James W. Davis, Esq., F.G.S.
2. "On *Aristosuchus pusillus*, Ow., being further Notes on the Fossils described by Sir R. Owen as *Poikilopleuron pusillus*, Ow." By Prof. H. G. Seeley, F.R.S., F.G.S.
3. "On *Patricosaurus merocratus*, Seeley, a Lizard from the Cambridge Greensand, preserved in the Woodwardian Museum of the University of Cambridge." By Prof. H. G. Seeley, F.R.S., F.G.S.
4. "On *Heterosuchus valdensis*, Seeley, a proœlian Crocodile from the Hastings Sands of Hastings." By Prof. H. G. Seeley, F.R.S., F.G.S.
5. "On a Sacrum, apparently indicating a new type of Bird (*Ornithodesmus cluniculus*, Seeley), from the Wealden of Brook." By Prof. H. G. Seeley, F.R.S., F.G.S.

The following specimens were exhibited:—

Specimens of *Patricosaurus merocratus*, Seeley, exhibited by Prof. T. McKenny Hughes, F.G.S., in illustration of Prof. Seeley's paper.
A cast of the specimen of *Heterosuchus valdensis*, Seeley, exhibited by Dr. H. Woodward, F.R.S., F.G.S., in illustration of Prof. Seeley's paper.

March 23, 1887.

Prof. J. W. JUDD, F.R.S., President, in the Chair.

Claude Black, Esq., 33 Kensington Gardens Square, W., was elected a Fellow of the Society.

The List of Donations to the Library was read.

The following communications were read:—

1. "Notes on the Structures and Relations of some of the older Rocks of Brittany." By T. G. Bonney, D.Sc., LL.D., F.R.S., V.P.G.S., Professor of Geology in University College, London, and Fellow of St. John's College, Cambridge.
2. "The Rocks of Sark, Herm, and Jethou." By Rev. E. Hill, M.A., F.G.S.
3. "Quartzite Boulders and Grooves in the Roger Mine at Dukinfield." By James Radcliffe, Esq., F.G.S.

The following specimens were exhibited:—

Rock-specimens and microscopic Rock-sections, exhibited by Prof. T. G. Bonney, F.R.S., V.P.G.S., and the Rev. Edwin Hill, F.G.S., in illustration of their papers.

A Quartzite Boulder in Coal, from the Roger Mine, Dukinfield, exhibited by J. Radcliffe, Esq., F.G.S., in illustration of his paper.

Three Quartzite Pebbles from Coal, exhibited by W. S. Gresley, Esq., F.G.S.

April 6, 1887.

Prof. J. W. JUDD, F.R.S., President, in the Chair.

Rev. Charles Leach, 56 Fernhead Road, London, N.W., was elected a Fellow; and Senh. J. F. N. Delgado, of Lisbon, and Prof. Albert Heim, of Zurich, Foreign Correspondents of the Society.

The List of Donations to the Library was read.

The PRESIDENT stated that the "Société Ouralienne d'Amateurs des Sciences Naturelles," established at Ekaterinebourg, had announced their intention to hold a Scientific and Industrial Exhibition at that place during the present year, opening on the 27th May, and closing on the 27th September.

On the requisition of a Fellow of the Society, three extracts from the Council Minute Book were read by the Secretary.

The following communications were read:—

1. "On the Rocks of the Malvern Hills.—Part II." By Frank Rutley, Esq., F.G.S.

2. "On the alleged Conversion of Crystalline Schists into Igneous Rocks in County Galway." By C. Callaway, D.Sc., F.G.S.

3. "A Preliminary Inquiry into the Genesis of the Crystalline Schists of the Malvern Hills." By C. Callaway, D.Sc., F.G.S.

The following specimens were exhibited:—

Specimens and photographs to illustrate the latest volcanic eruption in Northern California and its peculiar lava, as described by J. S. Diller, Esq., U. S. Geological Survey, exhibited by the President.

Rocks and microscopic rock-sections, exhibited by Frank Rutley, Esq., F.G.S., and Dr. C. Callaway, F.G.S., in illustration of their papers.

Photographs of microscopic rock-sections, exhibited by C. Bird, Esq., F.G.S., in illustration of Dr. Callaway's papers.

April 27, 1887.

Prof. J. W. JUDD, F.R.S., President, in the Chair.

F. G. Brook-Fox, Esq., Assoc. Memb. Inst. C.E., Indian Public Works Department, care of Messrs. Grindlay, Groom & Co., Bombay; and Alfred Woodhouse, Esq., Barberton, Transvaal, South Africa, were elected Fellows of the Society.

The List of Donations to the Library was read.

The following communications were read:—

1. "On the London Clay and Bagshot Beds of Aldershot." By H. G. Lyons, Esq., R.E., F.G.S.

2. "Supplementary Note on the Walton Common Section." By W. H. Hudleston, Esq., M.A., F.R.S., Sec.G.S.

Specimens were exhibited by W. H. Hudleston, Esq., F.R.S., Sec. G.S., in illustration of his paper.

May 11, 1887.

Prof. J. W. JUDD, F.R.S., President, in the Chair.

Hugh Ker Colville, Esq., Linley Hall, near Broseley, Shropshire, and J. Walter Gregory, Esq., Clare House, Goulton Road, Clapton, E., were elected Fellows of the Society.

The List of Donations to the Library was read.

The following communications were read:—

1. "Further Observations on *Hyperodapedon Gordoni*." By Prof. T. H. Huxley, LL.D., F.R.S., F.G.S.
2. "On the Rocks of the Essex Drift." By Rev. A. W. Rowe, M.A., F.G.S.
3. "On Tertiary Cyclostomatous Bryozoa from New Zealand." By Arthur W. Waters, Esq., F.G.S.

The following specimens were exhibited:—

Casts of specimens of *Hyperodapedon Gordoni*, exhibited by Dr. H. Woodward, F.R.S., V.P.G.S., in illustration of Prof. Huxley's paper.

Rock-specimens from the Essex Drift and microscopic rock-sections, exhibited by the Rev. A. W. Rowe, M.A., F.G.S., in illustration of his paper.

Specimens of rocks from the Boulder-clay of Finchley, exhibited by H. M. Klaassen, Esq., F.G.S.

Photograph of mud volcanos, "Devil's Woodyard," Trinidad, exhibited by R. V. Sherring, Esq., F.L.S.

May 25, 1887.

Prof. J. W. JUDD, F.R.S., President, in the Chair.

James William Barry, Esq., 97 Lansdowne Road, W.; William Fairley, Esq., Rugeley; and Joseph William Gray, Esq., Spring Hill, Wellington Road South, Stockport, were elected Fellows of the Society.

The List of Donations to the Library was read.

The following communications were read:—

1. "On the Remains of Fishes from the Keuper of Warwick and Nottingham." By E. T. Newton, Esq., F.G.S.; with Notes on their Mode of Occurrence by the Rev. P. B. Brodie, M.A., F.G.S., and E. Wilson, Esq., F.G.S.

2. "Considerations on the Date, Duration, and Conditions of the Glacial Period with reference to the Antiquity of Man." By Prof. Joseph Prestwich, M.A., F.R.S., F.G.S.

3. "Notes on some Carboniferous Species of *Murchisonia* in our Public Museums." By Miss Jane Donald. (Communicated by J. G. Goodchild, Esq., F.G.S.).

The following specimens were exhibited:—

Specimens of fishes from the Keuper near Shrewley, exhibited by the Rev. P. B. Brodie, F.G.S.; and specimens of the fishes from the Keuper near Nottingham, exhibited by E. Wilson, Esq., F.G.S., in illustration of the paper by E. T. Newton, Esq., F.G.S.

Specimen of *Chondrosteus acipenseroides*, Ag., exhibited by J. W. Davis, Esq., F.G.S.

June 8, 1887.

Prof. J. W. JUDD, F.R.S., President, in the Chair.

Edwyn F. Barclay, Esq., 20 Stanhope Gardens, S.W., and Edward Bouverie Luxmore, Esq., M.A., Bryn-Asaph, St. Asaph, were elected Fellows of the Society.

The List of Donations to the Library was read.

The following names of Fellows of the Society were read out for the first time in conformity with the Bye-laws Sec. VI. B, Art. 6, in consequence of the non-payment of the arrears of their contributions:—G. B. Luke, Esq., W. J. Nevill, Esq., N. W. Rudston-Read, Esq., F. Warwick, Esq., Rev. J. M^cCann, and D. Thomas, Esq.

The following communications were read:—

1. "A Revision of the Echinoidea from the Australian Tertiaries." By Prof. P. Martin Duncan, M.B., F.R.S., F.G.S.

2. "On the Lower Part of the Upper Cretaceous Series in West Suffolk and Norfolk." By A. J. Jukes-Browne, Esq., B.A., F.G.S., and W. Hill, Esq., F.G.S.

3. "On some Occurrences of Piedmontite-schist in Japan." By Prof. B. Kotô. (Communicated by Frank Rutley, Esq., F.G.S.).

The following specimens were exhibited:—

Specimens exhibited by Prof. P. Martin Duncan, M.B., F.R.S., F.G.S., in illustration of his paper.

Specimens exhibited by A. J. Jukes-Browne, Esq., F.G.S., and W. Hill, Esq., F.G.S., in illustration of their paper.

Microscopic rock-sections, exhibited by Prof. B. Kotô, in illustration of his paper.

June 23, 1887.

Prof. J. W. Judd, F.R.S., President, in the Chair.

Charles James Buckland, Esq., Athenæum Club, Sydney, and St. Stephen's Club, S.W.; Henry Ramsay Collins, Esq., Assoc. Memb. Inst. C.E., Durban, Natal; Joseph Landon, Esq., Training College, Saltley, Birmingham; Charles Davies Sherborn, Esq., 540 King's Road, Chelsea, S.W.; and John Udall, Esq., Red Street Board School, Birmingham, were elected Fellows of the Society.

The List of Donations to the Library was read.

The following names of Fellows of the Society were read out for the second time in conformity with the Bye-laws Sec. VI. B, Art. 6, in consequence of the non-payment of the arrears of their contributions:—G. B. Luke, Esq., W. J. Nevill, Esq., N. W. Rudston-Read, Esq., F. Warwick, Esq., Rev. J. M^cCann, and D. Thomas, Esq.

The following communications were read:—

1. "On Nepheline Rocks in Brazil, with special Reference to the Association of Phonolite and Foyaite." By Orville A. Derby, Esq., F.G.S.

2. "Notes on the Metamorphic Rocks of South Devon." By Miss Catherine A. Raisin, B.Sc. (Communicated by Prof. T. G. Bonney, D.Sc., LL.D., F.R.S., V.P.G.S.)

3. "On the Ancient Beach and Boulders near Braunton and Croyde in North Devon." By Prof. T. M'Kenny Hughes, M.A., F.G.S.

4. "Notes on the Formation of Coal-seams, as suggested by evidence collected chiefly in the Leicestershire and South Derbyshire Coal-field." By W. S. Gresley, Esq., F.G.S.

5. "Note on some Dinosaurian Remains in the Collection of A. Leeds, Esq. Part I. *Ornithopsis Leedsii*.—Part II. *Omosaurus*, sp." By J. W. Hulke, Esq., F.R.S., F.G.S.

6. "Notes on some Polyzoa from the Lias." By Edwin A. Walford, Esq., F.G.S.

7. "On the Superficial Geology of the Southern Portion of the Wealden Area." By J. Vincent Elsdon, Esq., B.Sc. (Communicated by the President.)

8. "Report on Palæo-botanical Investigations of the Tertiary Flora of Australia." By Dr. Constantin Baron von Ettingshausen, For.Corr.G.S.

9. "On some new Features in *Pelanechinus corallinus*." By T. T. Groom, Esq. (Communicated by Prof. T. M'Kenny Hughes, M.A., F.G.S.)

10. "On Boulders found in Seams of Coal." By John Spencer, Esq., F.G.S.

The following specimens were exhibited:—

Rock-specimens exhibited by O. A. Derby, Esq., F.G.S., in illustration of his paper.

Rock-specimens and microscopic sections exhibited by Miss Raisin, B.Sc., in illustration of her paper.

Iron model of a boulder, exhibited by John Spencer, Esq., F.G.S., in illustration of his paper.

Specimens exhibited by Edwin A. Walford, Esq., F.G.S., in illustration of his paper.

A Special General Meeting was held, at which the Rev. G. F. Whidborne was elected a Member of the Council, in the room of A. Champernowne, Esq., deceased.

ADDITIONS

TO THE

LIBRARY AND MUSEUM OF THE GEOLOGICAL SOCIETY.

SESSION 1886-87.

I. ADDITIONS TO THE LIBRARY.

1. PERIODICALS AND PUBLICATIONS OF LEARNED SOCIETIES.

Presented by the respective Societies and Editors, if not otherwise stated.

Academy. Nos. 738-764. 1886.

——. Nos. 765-789. 1887.

Adelaide. Royal Society of South Australia. Transactions and Proceedings and Report. Vol. viii. 1884-85. 1886.

J. J. East. On a Geological Section from the Head of St. Vincent Gulf eastward across the Wakefield and Light-River Basins, 1.—G. Scouler. Past Climatic Changes, with special reference to the occurrence of a Glacial Epoch in Australia, 36.—R. Tate. Post-Miocene Climate in South Australia, 49.—W. Howchin. On the Fossil Foraminifera from the Government Boring at Hergott, with general remarks on the Section, and on other forms of Microzoa observed therein, 79.—R. Tate. Supplemental Notes on the Palliobranchs of the Older Tertiary of Australia, and a description of a new Species of *Rhynchonella*, 94.—R. Tate. The Lamellibranchs of the Older Tertiary of Australia, Part 1, 96.

Agram. Societas Historico-Naturalis Croatica. Glasnik. Godina 1. Broj. 1-6. (8vo.) 1886.

D. Gorjanovic-Kramberger. Palæoichthyologische Beiträge, 122.

Analyst. Vol. xi. Nos. 122-128. 1886.

A. Percy Smith. On the Micro-chemical examination of Crystalline Rocks, 191.

——. Vol. xii. Nos. 129-134. 1887.

Annals and Magazine of Natural History. Ser. 5. Vol. xviii. Nos. 103-108. 1886. *Purchased.*

H. A. Nicholson. On some new or imperfectly-known Species of Stromatoporoids, 8.—H. Rauff. On the Genus *Hindia*, 169.—H. B. Brady. Note on *Orbitolites italica*, Costa, sp. (*Orbitolites tenuissima*, Carpenter), 191.—P. M. Duncan. On the Genus *Hindia* and its Species, 226.—T. Rupert Jones and James W. Kirkby. Notes on the Palæozoic Bivalved Entomostraca, No. XXII., 249.—P. H. Carpenter. Note on

the Structure of *Crotalocrinus*, 397.—R. H. Traquair. On *Harpacanthus*, a new Genus of Carboniferous Selachian Spines, 493.

Annals and Magazine of Natural History. Ser. 5. Vol. xix. Nos. 109–114. 1887. *Purchased.*

H. A. Nicholson. On some new or imperfectly-known Species of Stromatoporoids, 1.—G. R. Vine. Notes on a Species of *Entalophora* from the Neocomian Clay of Lincolnshire, 17.—P. H. Carpenter. The Morphology of *Antedon rosacea*, 19.—G. J. Hinde. On the Genus *Hindia*, Duncan, and the Name of its Typical Species, 67.—P. H. Carpenter. The Generic Position of *Solanocrinus*, 81.—P. M. Duncan and W. P. Sladen. On some Points in the Morphology and Classification of the Saleniidæ, Agassiz, 117.—T. Rupert Jones and James W. Kirkby. Notes on the Palæozoic Bivalved Entomostraca. No. XXIII., 177; No. XXIV., 400.—P. M. Duncan. A reply to Dr. G. J. Hinde's Communication "On the Genus *Hindia*, Dunc., and the name of its Typical Species," 260.

Athenæum (Journal). Nos. 3061–3087. 1886.

——. Nos. 3088–3112. 1887.

——. Parts 702–708. 1886.

——. Parts 709–714. 1887.

Barnsley. Midland Institute of Mining, Civil, and Mechanical Engineers. Transactions. Vol. x. Parts 82–87. 1886 and 1887.

R. Gascoyne. On the Eastern Extension of the Leeds and Nottingham Coal-field, 250.

Basel. Naturforschende Gesellschaft. Verhandlungen. Theil viii. Heft 1. 1886.

V. Gilliéron. La faune des couches à *Mytilus* considérée comme phase méconnue de la transformation de formes animales, 133.

——. Schweizerische paläontologische Gesellschaft. Abhandlungen. Vol. xiii. 1886. 1886. *Purchased.*

F. Koby. Monographie des polypiers jurassiques de la Suisse, 6^e partie, No. 1.—A. Wettstein. Ueber die Fischfauna des tertiären Glarnerschiefers, No. 2.—P. de Loriol et l'Abbé Bourgeat. Etude sur les mollusques des couches de Valfin, No. 3.

Bath Natural-History and Antiquarian Field Club. Vol. vi. No. 2. 1887.

H. B. Woodward. Notes on the Geology of Brent Knoll, in Somersetshire, 125.—H. B. Woodward. Notes on the Ham Hill Stone, 182.

——. Royal Literary and Scientific Institution. 16th Annual Report, 1884. 1885.

Belfast Natural-History and Philosophical Society. Report and Proceedings for 1885–86. 1886.

W. H. Patterson. The History and Legends of some Irish Lakes, 7.—W. Swanston. Important local geological discovery, 18.

——. Naturalists' Field Club. Annual Report and Proceedings. 1885–86. Series 2. Vol. ii. Part 6. 1887.

Berlin. Deutsche geologische Gesellschaft. Zeitschrift. Band xxxviii. Hefte 2-4. 1886.

G. Berendt. Der oberoligocäne Meeressand zwischen Elbe und Oder, 255.—G. De Geer. Ueber ein Conglomerat im Urgebirge bei Westanå in Schönen, 269.—J. Walther und P. Schirlitz. Studien zur Geologie des Golfes von Neapel, 295.—R. Beck. Beiträge zur Kenntniss der Flora des sächsischen Oligocäns, 342.—F. Wahnschaffe. Die lössartigen Bildungen am Rande des norddeutschen Flachlandes, 353.—A. v. Groddeck. Zur Kenntniss der Zinnerzlagerstätten des Mount Bischoff in Tasmanien, 370.—K. Keilhack. Beiträge zur Geologie der Insel Island, 376.—C. W. Schmidt. Ueber das Gebirgsland von Usambara, 450.—F. J. P. Van Calker. *Ananchytes sulcatus* in Diluvialgeschieben der Gegend von Nieuw Amsterdam, 452.—Vanhöfen. Einige für Ostpreussen neue Geschiebe, 454.—Gürich. Ueber *Dactylosaurus*, 457.—A. Penck. Beobachtungen über den Aufbau des Elballuvium bei Hamburg von Herrn E. Wichmann, 458.—J. Felix. Untersuchungen über fossile Hölzer, 483.—H. Credner. Das "marine Oberoligocän" von Markranstadt bei Leipzig, 493.—C. Rammelsberg. Ueber die chemische Natur des Eudialyts, 497.—C. Rammelsberg. Beiträge zur chemischen Kenntniss des Vesuvians, 507.—A. Wichmann. Zur Geologie von Nowaja Semlja, 516.—W. Dames. Ueber einige Crustaceen aus den Kreideablagerungen des Libanon, 551.—H. Credner. Die Stegocephalen aus dem Rothliegenden des Plauen'schen Grundes bei Dresden, vi, 576.—K. Öbbecke. Ueber den Glaukophan und seine Verbreitung in Gesteinen, 634.—E. Geinitz. Ueber Äsar und Kames in Mecklenburg, 654.—F. Römer. Ueber ein massenhaftes Vorkommen von grossen Granat-Krystallen im Boden der Stadt Breslau, 723.—G. Böhm. Die Gattungen *Pachymegaloden* und *Durgo*, 728.—W. Bruhms. Der Porphyritzung von Wilsdruff-Potschappel, 736.—F. Römer. Notiz über Bilobiten-ähnliche als Diluvial-Geschiebe vorkommende Körper, 762.—C. Ochsenius. Ueber das Alter einiger Theile der südamericanischen Anden, 766.—J. T. Sterzel. Neuer Beiträge zur Kenntniss von *Dicksonites Pluckeneti*, Brongniart, sp., 773.—F. Nötling. Ueber die Lagerungsverhältnisse einer quartären Fauna im Gebiete des Jordanthals, 807.—F. Nötling. Entwurf einer Gliederung der Kreideformation in Syrien und Palästina, 824.—K. Picard. Ueber Ophiuren aus dem Oberen Muschelkalk bei Schlotheim in Thüringen, 876.—A. von Könen. Ueber das Mittel Oligocän von Aarhus, Jütland, 883.—H. Kunisch. *Voltzia krapitzensis*, nov. spec., aus dem Muschelkalke Oberschlesiens, 894.—C. Schlüter. *Archæocyathus* im russischen Silur?, 899.—E. Geinitz. Ausstehender oligocäner Sand in Mecklenburg, 910.—C. Ochsenius. Ueber das Auftreten von Phosphorsäure im Natron-salpeterbecken von Chile, 911.

——. Gesellschaft naturforschender Freunde. Sitzungs-Berichte. Jahrgang 1886. 1886.

E. Koken. Ueber Gehirn und Gehör fossiler Crocodiliden, 2.—E. Weiss. Ueber Sigillarien, 6.—F. Nötling. Vorlegung einiger fossiler Haifischzähne, 13.—F. Nötling. Vorlegung von Crustaceenresten aus dem oberoligocänen Sternberger Gestein, 32.—W. Dames. Vorlegung eines subfossilen Crocodil-Humerus von Madagascar, 68.—E. Weiss. Mittheilungen zur Sigillarien-Frage, 70.—E. v. Martens. Vorzeigung von Prof. Schweinfurth gesammelter subfossiler Süsswasser-Conchylien aus dem Fajum-Becken in Ägypten, 126.

——. Königlich-preussische Akademie der Wissenschaften. Sitzungsberichte, 1886. Nos. 1-53. 1886.

C. Rammelsberg. Ueber die chemische Natur des Eudialyts, 441.—

J. Kiessling. Die Bewegung des Krakatau-Rauches im September 1883, 529.—J. Partsch. Bericht über die wissenschaftlichen Ergebnisse seiner Reisen auf den Inseln des Ionischen Meeres, 615.—C. Gottsche. Geologische Skizze von Korea, 857.—J. Roth. Beiträge zur Petrographie von Korea, 875.—J. Roth. Vulcanische Ausbruch in Nord-Neuseeland, 940.—J. Roth. Erdbeben in Malta, 943.—M. Websky. Ueber Caracolit und Percylit, 1045.—A. Arzruni. Mineralogisches aus dem Sanárka-Gebiet im Süd-Ural, 1211.

Berlin. Königlich-preussische Akademie der Wissenschaften. Sitzungsberichte, 1887. Nos. 1–18. 1887.

———. Königlich preussische geologische Landesanstalt und Bergakademie. Jahrbuch. 1880–84. 1881–85.

———. ———. Jahrbuch für das Jahr 1885. (8vo.) 1886.

Mittheilungen aus der Anstalt, vii–xv.—A. von Groddeck. Studien über Thonschiefer, Gangthonschiefer und Sericitschiefer, 1.—A. von Könen. Ueber das Verhalten von Dislokationen im nordwestlichen Deutschland, 53.—H. Loretz. Zur Beurtheilung der beiden Haupt-Streichrichtungen im südöstlichen Thüringer Walde, besonders in der Gegend von Gräfenthal, 84.—E. H. Zimmermann. Ein neuer Monomyarie aus dem ostthüringischen Zechstein (*Prospondylus Liebecanus*), 105.—E. Weiss. Untersuchungen im Rybniker Steinkohlengebiete Oberschlesiens, 120.—F. Wahuschaffe. Mittheilungen über das Alluvium der Rathenower Gegend, 124.—H. Grebe. Ueber Thalbildung auf der linken Rheinseite, insbesondere über die Bildung des untern Nahethales, 133.—H. Grebe. Neuere Beobachtungen über vulkanische Erscheinungen am Mosenberg bei Manderscheid, bei Birresborn und in der Gegend von Bertrich, 165.—K. T. Liebe und E. Zimmermann. Die jüngeren Eruptivgebilde im Südwesten Ostthüringens, 178.—K. A. Lossen. Geologische und petrographische Beiträge zur Kenntniss des Harzes, 191.—H. Schröder. Ueber zwei neue Fundpunkte mariner Diluvialconchylien in Ostpreussen, 219.—C. E. Weiss. Gerölle in und auf der Kohle von Steinkohlenflötzen besonders in Oberschlesien, 242.—W. Frantzen. Die Entstehung der Lösspuppen in den älteren lössartigen Thonablagerungen des Werrathales bei Meiningen, 257.—J. G. Bornemann. Beiträge zur Kenntniss des Muschelkalks in Thüringen, 267.—F. Klockmann. Charakteristische Diabas- und Gabbro-Typen unter den norddeutschen Diluvialgeschieben, 322.—G. Berendt. Geognostische Skizze der Gegend von Glogau und das Tiefbohrloch im dortiger Kriegsschule, 347.—C. E. Weiss. Ueber eine Buntsandstein-Sigillaria und deren nächste Verwandte, 356.—C. E. Weiss. Nachtrag zu der Abhandlung "Gerölle in und auf der Kohle von Steinkohlenflötzen, besonders in Oberschlesien," 362.—H. Grebe. Ueber die Verbreitung vulkanischen Sandes auf den Hochflächen zu beiden Seiten der Mosel, 364.—R. Klebs. Gastropoden im Bernstein, 366.—A. Jentzsch. Das Profil der Eisenbahn Berent-Schöneck-Hohenstein, 395.—A. Jentzsch. Das Profil der Eisenbahn Zajonskowo-Löbau, 424.

E. Ramann. Der Ortstein und ähnliche Secundärbildungen in den Diluvial- und Alluvial-Sanden, 1.

———. Paläontologische Abhandlungen. Band iii. Hefte 3 & 4. 1886. *Purchased.*

F. Frech. Die Cyathophylliden und Zaphrentiden des deutschen Mitteldevon, 1 (Heft 3).—J. T. Sterzel. Die Flora des Rothliegenden im nordwestlichen Sachsen, 1 (Heft 4).

Berlin. Zeitschrift für das Berg-, Hütten- und Salinenwesen im preussischen Staate. Band xxxiv. Lief. 3 & 4. 1886. *Presented by the Ministry of Public Works.*

Brathuhn. Die Umarbeitung der Oberharzer Grubenrisse, 175.—Grassmann. Das Richelsdorfer Kupfer- und Kobaltwerk in Hessen, 195.—W. Rittershaus. Der Iberger Kalkstock bei Grund am Harze, 207.

——. ——. Band xxxiv. Statistische Lieferungen 1–3. 1886.

——. ——. Band xxxiv. Atlas. Tafeln 1–19. 1886.

——. ——. Band xxxv. Lief. 1 & 2. 1887.

E. Hilger. Die Ablagerung der productiven Steinkohlenformation in der Horst-Recklinghausener Mulde des Niederrheinisch-Westfälischen Steinkohlenbeckens, unter besonderer Berücksichtigung der neuesten Aufschlüsse der Zechen Schlägel und Eisen, Ewald, Graf Bismarck, General Blumenthal und König Ludwig, 30.—E. Cappell. Ueber die Erzführung der Oberschlesischen Trias nördlich von Tarnowitz, O.S., 99.

——. ——. Band xxxv. Atlas. Tafeln 1–12. 1887.

Bern. Schweizer Alpenclub. Jahrbuch. Jahrgang 21, 1885–86. 1886. Also Beilagen. *Purchased.*

A. Heim. Notizen über Wirkungen des Blitzschlages auf Gesteine, 342.—F. A. Forel. Les variations périodiques des glaciers des Alps, 358.

——. ——. ——. Repertorium und Ortsregister. Band i.–xx. 8vo. 1886.

Birmingham. Mason Science College. Calendar for the Session 1886–87. 1886.

Birmingham Philosophical Society. Proceedings. Vol. v. Part 1 (1885–86). 1886.

C. Davison. On the Existence of Undisturbed Spots in Earthquake-shaken Areas, 57.—J. H. Player. Analyses of Basalts, 122.—H. W. Crosskey. Note on the Glacial Geology of the district around Loch Sween, Argyllshire, 219.

Bordeaux. Société Linnéenne. Actes. Vol. xxxiv. (Sér. 4, Tome ix.). 1885.

E. A. Benoist. Description géologique et paléontologique des communes de Saint-Estèphe et de Vertheuil, 79, 301.—E. A. Benoist. Révision de la list des espèces fossiles, appartenant aux familles des *Buccinidæ* et des *Nassidæ*, trouvées dans les faluns miocènes du Sud-Ouest, xvi.—E. A. Benoist. Sables éruptifs des gravières de Monrepos, xxiv.—E. A. Benoist. Compte-rendu géologique de l'excursion trimestrielle faite à Villandraut et à Balizac, xxxi.—E. A. Benoist. Forage d'un puits au moulin de Perron, commune de Landiras, xxxiii.—E. A. Benoist. Le puits artésien du Parc Bordelas, l.—E. A. Benoist. Compte-rendu géologique de l'excursion trimestrielle à Vertheuil, lxii.

Boston (Cambridge). American Academy of Arts and Sciences. Memoirs. Centennial volume. Vol. xi. Part 4. Nos. 4 & 5. 1886.

——. ——. Proceedings. N. S. Vol. xiii. (whole ser. vol. xxi.). Part 2. 1886.

P. W. Huntington. On the Crystalline Structure of Iron Meteorites, 478.

Boston (Cambridge). American Academy of Arts and Sciences. Proceedings. N. S. Vol. xiv. (whole ser. vol. xxii.). Part 1. 1886. 1887.

G. W. Leighton. Contributions from the Chemical Laboratory of Harvard College, 158.

———. Society of Natural History. Memoirs. Vol. iii. Nos. 12 & 13. 1886.

S. H. Scudder. The oldest known Insect-larva, *Mormolucoides articulatus*, from the Connecticut-River Rocks, 431.—S. H. Scudder. Note on the supposed Myriapodan Genus *Trichiulus*, 433.—S. H. Scudder. A Review of Mesozoic Cockroaches, 439.

———. ———. Proceedings. Vol. xxiii. Part 2. 1886.

M. E. Wadsworth. On the relation of the "Keweenaw Series" to the Eastern Sandstone in the vicinity of Torch Lake, Michigan, 172.—M. E. Wadsworth. The Theories of Ore-Deposits, 197.—M. E. Wadsworth. On a supposed Fossil from the Copper-bearing Rocks of Lake Superior, 208.

Brisbane. Acclimatization Society of Queensland. 20th Report, 1885. 1886.

Bristol Museum and Library. Report of Proceedings at the 16th Annual Meeting, held 24th February, 1887. 1887.

British Association for the Advancement of Science. Report of the 55th Meeting, held at Aberdeen in September 1885. 1886.

J. D. Everett. Seventeenth Report of the Committee appointed for the purpose of investigating the Rate of Increase of Underground Temperature downwards in various localities of Dry Land and under Water, 93.—T. Rupert Jones. Third Report of the Committee on the Fossil Phyllopora of the Palæozoic Rocks, 326.—J. Milne. Fifth Report of the Committee appointed for the purpose of investigating the Earthquake Phenomena of Japan, 362.—C. E. De Rance. Eleventh Report of the Committee appointed for the purpose of investigating the Circulation of Underground Waters in the Permeable Formations of England and Wales, and the Quantity and Character of the Water supplied to various Towns and Districts from these Formations, 382.—H. J. Johnston-Lavis. Report of the Committee for the Investigation of the Volcanic Phenomena of Vesuvius, 395.—J. S. Gardner. Report of the Committee on the Fossil Plants of the Tertiary and Secondary Beds of the United Kingdom, 396.—W. Topley. Report of the Committee appointed for the purpose of inquiring into the Rate of Erosion of the Sea-coasts of England and Wales, and the Influence of the Artificial Abstraction of Shingle or other material in that action, 404.—G. R. Vine. Report of the Committee appointed for the purpose of reporting on recent Polyzoa, 481.—T. G. Bonney. Report on the Rocks collected by H. H. Johnstone, Esq., from the upper part of the Kilima-njaro massif, 682.—C. Meldrum. A Tabular Statement of the Dates at which, and the Localities where, Pumice or Volcanic Dust was seen in the Indian Ocean in 1883-84, 773.—W. Whitaker. List of Works on the Geology, Mineralogy, and Palæontology of Staffordshire, Worcestershire, and Warwickshire, 780.—A. Harker. On Slaty Cleavage and Allied Rock-Structures, with special reference to the Mechanical Theories of their Origin, 813.—J. W. Judd. Presidential Address to Section C, Geology, 994.—G. A. Lebour. On some recent Earthquakes on the Durham Coast, and their probable cause, 1013.—E.

Hull. Notice of an Outline Geological Map of Lower Egypt, Arabia Petræa, and Palestine, 1015.—E. Hull. On the Occurrence of Lower Old Red Conglomerate in the Promontory of the Fanad, North Donegal, 1016.—T. G. Bonney. On Bastite-Serpentine and Troktolite in Aberdeenshire; with a Note on the Rock of the Black Dog, 1016.—W. Ivison Macadam. On certain Diatomaceous Deposits (Diatomite) from the Peat of Aberdeenshire, 1017.—T. Anderson. The Volcanoes of Auvergne, 1017.—R. L. Playfair. On the Re-discovery of lost Numidian Marbles in Algeria and Tunis, 1018.—W. Watson. The Chasm called the Black Rock of Kiltearn, 1018.—J. Davidson. The Bass of Inverurie, a fragment of an ancient Alluvial Bed, 1019.—H. Carvill Lewis. The Direction of Glaciation as ascertained by the Form of the Striæ, 1019.—W. F. Stanley. Proposed Conditions to account for a former Glacial Period in Great Britain, existing under similar meteorological conditions to those that rule at the present time, 1020.—H. Hicks. On the Fynnon Beuno and Cae Gwyn Bone-Caves, North Wales, 1021.—J. G. Phillips. The Elgin Sandstones, 1023.—R. H. Traquair. Preliminary Note on a new Fossil Reptile recently discovered at New Spynie, near Elgin, 1025.—C. Lapworth. The Highland Controversy in British Geology; its Causes, Course, and Consequences, 1025.—B. N. Peach and J. Horne. The Geology of Durness and Eriboll, with special reference to the Highland Controversy, 1027.—T. G. Bonney. Preliminary Note on some Traverses of the Crystalline District of the Central Alps, 1027.—H. C. Lewis. Some Examples of Pressure-Fluxion in Pennsylvania, 1029.—J. Gunn. On Rocks of Central Caithness, 1030.—A. Renard. On some Rock-Specimens from the Islands of the Fernando Noronha Group, 1031.—E. Hill. On the Average Density of Meteorites compared with that of the Earth, 1031.—H. Drummond. Notes on a recent Examination of the Geology of East Central Africa, 1032.—M. Schuster. Some Results of the Crystallographic Study of Danburite, 1033.—Sir R. Owen. American Evidences of Eocene Mammals of the "Plastic Clay" Period, 1033.—H. Miller. Some Results of a detailed Survey of the Old Coast-lines near Trondhjem, Norway, 1033.—J. Melvin. The Parallel Roads of Lochaber, 1035.—B. N. Peach and J. Horne. Further Evidence of the Extension of the Ice in the North Sea during the Glacial Period, 1036.—H. M. Cadell. Recent Advances in West Lothian Geology, 1037.—F. Clowes. Barium Sulphate as a Cementing Material in Sandstone, 1038.—A. C. G. Cameron. Notes on Fuller's Earth and its applications, 1039.—J. C. Howden. On the Glacial Deposits at Montrose, 1040.—A. Ross. Notes on the Rocks of St. Kilda, 1040.—W. Whitaker. On Deep Borings at Chatham: a Contribution to the Deep-seated Geology of the London Basin, 1041.—W. Whitaker. On the Waterworks at Goldstone Road, Brighton, 1041.—O. C. Marsh. On the Size of the Brain in Extinct Animals, 1065.—D'Arcy W. Thompson. On the Hind Limb of Ichthyosaurus and on the Morphology of Vertebrate Appendages, 1065.—E. Hull. On the Origin of the Fishes of the Sea of Galilee, 1063.—E. Hull. On the Cause of the Extreme Dissimilarity of the Faunas of the Red Sea and Mediterranean, 1068.—T. Wilson. A new Cave-Man of Mentone, 1218.—W. Pengelly. Happaway Cavern, Torquay, 1219.

Brussels. Musée Royal d'Histoire Naturelle de Belgique. Bulletin. Tome iv. Nos. 2-4. 1886.

P. Pelseneer. Notice sur un Crustacé des sables verts de Grandpré, 47.—A. Rutot. La tranchée de Hainin, 61.—L. Dollo. Première Note sur les Chéoniens du Bruxellien (éocène moyen) de la Belgique, 75.—L. Dollo. Première Note sur les Chéoniens landeniens (éocène inférieur) de la Belgique, 129.—P. Pelseneer. Notice sur les Crustacés décapodes du

Maestrichtien du Limbourg, 161.—A. Renard. Notice sur la géologie de l'île de Kerguelen, 223.—C. Klement. Notice sur la composition chimique de la météorite de Saint-Denis-Westrem (Flandre orientale), 273.

Brussels. Société Royale Malacologique de Belgique. Annales. Tome xx. (Sér. 3, Tome v.) 1885. 1886.

Mémoires.

F. L. Cornet. Sur une coupe observée à Mesvin dans le terrain quaternaire, 3.—É. Delvaux. Époque quaternaire—Quelques mots sur le grand bloc erratique d'Oudenbosch, près de Bréda, et sur le dépôt de roches granitiques scandinaves découvert dans la région, 6.—É. Delvaux. Note succincte sur l'excursion de la Société géologique de Belgique à Spa, Stavelot et Lammersdorf, 15.—A. Rutot. Sur le terrain quaternaire des environs de Mons, 24.—L. Foresti. Note sur le sous-genre *Smendovia*, Tournouër (1882), 27.—A. Meunier et Éd. Pergens. Nouveaux Bryozoaires du Crétacé Supérieur, 32.—A. Nobre. Catalogue des Mollusques des environs de Coïmbre (Portugal), 45.

Bulletin.

O. Van Ertborn et P. Cogels. Note sur les conséquences de certaines erreurs d'interprétation au point de vue géologique, vii, xix.—E. Van den Broeck. Réponse à la note de MM. Van Ertborn et P. Cogels, x, xxii.—A. Rutot. Quelques mots sur l'étage Asschien, xiii.—E. Van den Broeck. De la constitution géologique du territoire de la feuille d'Aerschot, d'après la carte au 1:20,000 de MM. Ertborn et Cogels, et d'après les levés du service officiel, lix.—F. L. Cornet. Note sur deux gisements des sables et argiles d'Hautrages, lxxiii.—A. Rutot. Sur les résultats de l'étude des étages Landenien et Heersien sur les feuilles de Landen, Saint-Trond et Heers, lxxv.—A. Rutot et E. Van den Broeck. Note sur la nouvelle classification du terrain quaternaire dans la basse et dans la moyenne Belgique, lxxviii.—A. Rutot et E. Van den Broeck. Note préliminaire sur l'âge des diverses couches confondues sous le nom de Tufeau de Cibly, xciii.—F. L. Cornet et A. Briart.—Sur l'âge du tufeau de Cibly, c.—A. Rutot et E. Van den Broeck. Sur l'âge tertiaire du tufeau de Cibly, cviii, cxiii.

———. Procès-Verbaux des Séances. Tome xv. 1886–87.

Pp. i–cxliii. 1886–87.

A. Briart et H. Crosse. Rapport sur "Catalogue des coquilles fossiles de l'éocène des environs de Paris," v.—E. Van den Broeck. Note sur une observation faite à Schriek (Feuille d'Heyst-op-den-Berg) montrant, contrairement aux Levés Géologiques de MM. Van Ertborn et Cogels, l'absence d'Éocène Wemmélien dans le territoire de la Feuille d'Heyst-op-den-Berg, x.—P. Cogels et O. Van Ertborn. De la limite méridionale de l'argile de Boom sur la planche d'Heyst-op-den-Berg, xvi.—P. Cogels et O. Van Ertborn. Contribution à l'étude des terrains quaternaires, xxiii.—E. Van den Broeck. Quelques mots en réponse aux lectures faites par MM. Cogels et Van Ertborn, xxxviii.—O. Van Ertborn. Les coupes et la valeur scientifique des échantillons de quelques puits artésiens, &c. &c., xlv.—J. Lorie. Note sur le forage d'Arnhem, xlv.—P. Cogels et O. Van Ertborn. De l'Infraheersien et du niveau occupé par le crétacé sur le territoire de la feuille de Bilsen, lix.—P. Cogels et O. Van Ertborn. Note sur un gisement de bois de Rennes incisés par l'Homme dans les argiles quaternaires de la Campine, ci.—G. Vincent. Note sur un gîte fossilifère quaternaire observé à Veeweyde, près de Duysbourg, cxxiv.—D. Raeymaekers. Sur la présence de fossiles tongriens fluvio-marins sur la planchette de Louvain, cxxvi.

Buckhurst Hill. Essex Field Club. Transactions. Vol. iv. Part 2 (1886). 1886.

W. Whitaker. Some Essex Well-Sections, 149.

———. ———. Essex Naturalist (continuation of above). 1887. Nos. 1–4. 1887.

T. V. Holmes. On the Subsidence at Lexden, near Colchester, 1.—W. G. Smith. Primæval Man in the Valley of the Lea, 36, 83.—O. Fisher. On the Subsidence at Lexden, near Colchester, in 1862, 39.

Buda Pest. Magyar Földtani Társulat. (Ungarische geologische Gesellschaft. Geologische Mittheilungen.) Földtani Közlöny. Kötet xv. Fuzet 6–12 (1885). 1885.

J. Böckh. A. m. Kir. Földtani Intézet évi jelentése 1884-ről, 217.—J. Matyasovszky. A Rézhegyseg É Ny-i végén, a Nagy-Báród és Felső-Darna között eszközölt részletes fölvételről, 246.—L. Lóczy. A Maros és a Fehér-Körös Közötti hegyvidéken eszközölt földtani részletes fölvételről, 250.—G. Pethö. A Lippa-Odvos. Könop környéki krétaterületről, 266.—G. Pethö. Baltavár ösemlöseiről, 273.—A. Koch. A gyalui havasok É-i szélén, Kalotaszegben és a Vlegyásza hegységben végzett részletes földtani felvételről, 284.—L. Roth. A Bozovicstól É-ra fekvő hegysegrész Krassó-Szörénymegyében, 296.—G. Halaváts. Az Oravicza-Román-Bogsán környékén eszközölt részletes földtani fölvételről, 313.—F. Schafarzik. Mehádia és Herkules-fürdő környéke Krassó-Szörénymegyében, 324.—A. Gesell. A Selmezbánya és Szelakna környékén eszközölt részletes banya-geológiai fölvételekről, 335.—J. Böckh. Jahresbericht der Kön. ungar. geologischen Anstalt für 1884, 393.—J. v. Matyasovszky. Ueber die geologische Detailaufnahme am Nordwest-Ende des Rézgebirges, in den Gegend zwischen Nagy-Báród und Felső-Derna, 423.—L. v. Lóczy. Ueber die im Sommer des Jahres 1884 in der Gebirgsgegend zwischen der Maros und Fehér-Körös ausgeführten geologischen Special-Aufnahmen, 427.—J. Pethö. Ueber das Kreide-Gebiet zwischen Lippa, Odvos und Konop, 446.—J. Pethö. Ueber die tertiären Säugethier-Ueberreste von Baltavár, 455.—A. Koch. Ueber die am Rande des Gyaluer Hochgebirges, in der Kalotaszeg und im Vlegyásza-Gebirge im Sommer 1884 ausgeführte geolog. Specialaufnahme, 465.—L. Roth. Ueber den Gebirgsthail nördlich von Bozovics, im Comitate Krassó-Szörény, 479.—J. Halaváts. Ueber die im Jahre 1884 in der Umgebung von Oravicza-Román-Bogsán durchgeführte geolog. Specialaufnahme, 500.—F. Schafarzik. Ueber das Gebirge zwische Mehádia und Herkulesbad im Comitate Krassó-Szörény, 512.—A. Gesell. Ueber die geologischen Detailaufnahmen in der Umgebung von Schemnitz und Windschacht, 525.—T. Szontagh. Petrographische Beschreibung von Gesteinen aus dem Sohler Comitate im nördlichen Ungarn, 540.—L. Roth. Gekritztes Geschiebe von der Südseite der Hohen-Tátra, 557.—L. Roth. Spuren einstiger Gletscher in der Niederen-Tátra, 558.

———. ———. (———) ———. Kötet xvi. Fuzet 1 & 2 (1886). 1886.

J. Szabo. Elnöki megnyitó beszéd a magyarhoni Földtani Társulat Közgyűlésén 1886 január 13-án, 1.—V. Wartha. A szerpentin-chlorid-csoport ásványairól, 7.—A. Kalecsinszky. Közlemények a magyar kir. földtani intézel chemiai laboratoriumából, 12.—J. Szabo. Jelentés a harmadik nemzetközi geológiai kongresszusról Berlinben 1885, 17.—G. Téglás. Ujabb adatok az erdélyi medence ösemlöseihez, 39.—G. Pethö. Suess előadása a sujto léyről, 44.—V. Wartha. Ueber die Mineralien der Serpentin-Chlorit-Gruppe, 79.—A. Kalecsinszky. Mittheilungen aus dem chemischen Laboratorium der kön. ung. geologischen Anstalt, 84.

Buda Pest. Magyar Földtani Társulat. (Ungarische geologische Gesellschaft. Geologische Mittheilungen.) Földtani Közlöny. Kotet xvi. Füzet 7–12 (1886). 1886.

F. Schafarzik. Levél a Kaukázus vidékéről, 209.—J. Budai. A persányi hegység másodkori eruptív kőzetei, 211.—L. Cseh. Avihnyeí O-Antaltarna bányatelep földtani viszonyai, 224.—J. Halaváts. Magyarországi Valenciennesiák, 227.—F. Schafarzik. Briefliche Mittheilung aus dem Kaukasus, 257.—J. Budai. Die secundären Eruptivgesteine des Persányer Gebirges, 259.—L. Cseh. Die geologischen Verhältnisse der Alt-Antonstollner Berghandlung in Vihnye, 274.—J. Halaváts. Valenciennesia in der fossilen Fauna Ungarns, 279.—S. Schmidt. Levél a Szerkesztokhoz, 305.—G. Primics. Vaskos kvarczfélék előfordulása Tekerön, 308.—F. Jablonszky. A jabloulkai tözegekrol, 314.—P. Szokol. Válasz Dr. Schafarzik Ferencz urnak, 320.—F. Schafarzik. A propylit kérdéséről, 322.—G. Primics. Das Vorkommen der derben Quarzvarietaten bei Tekerö, 247.—F. Jablonszky. Die Torfmoore von Jablonka, 354.—P. Szokol. Erwiederung, 357.—T. Schafarzik. Ueber die Propylite-Frage, 358.

———. Magyar Királyi. Földtani Intézet. (Königlich-ungarische geologische Anstalt) Mittheilungen aus dem Jahrbuch. Band vii. Heft 5. 1886.

A. Gesell. Geologische Verhältnisse des Steinsalzbergbaugesbietes von Soóvár mit rücksicht auf die wiederöffnung der ertränkten Steinsalzgrube, 195.

———. ———. ———. Band viii. Heft 1. 1886.

E. Herbich. Paläontologische Studien über die Kalkklippen des siebenbürgischen Erzgebirges, 1.

———. ———. ———. Band viii. Heft 4. 1887.

J. Halaváts. Paläontologische Daten zur Kenntniss der Fauna der Sudungarischen Neogen-Ablagerungen, 125.

———. ———. Kiadványai. Konyv-és Térképtárának. I. Potczimjegyzéke. (Erster Nachtrag zum Katalog der Bibliothek und allg. Kartensammlung.) 1886.

———. ———. A Magyar Királyi Földtani Intézet es ennek Kiallitási Tárgyai, az 1885, evi Budapesti Altalanós Kiollitás Alkalmából, összeallitotta Böckh János. 8vo. 1885.

———. Kon. ung. geologische Anstalt. Die königlich-ungarische geologische Anstalt und deren Ausstellungs-Objecte zu der 1885 in Budapest abgehaltenen allgemeinen Ausstellung, zusammengestellt von Johann Böckh. 8vo. 1885.

Buenos Aires. Academia Nacional de Ciencias en Córdoba. Actas. Tomo iv. Entrega 1. 1882.

———. ———. Boletin. Tomo v. Entregas 1 & 2. 1883.

F. Ameghino. Sobre una coleccion de mamiferos fósiles del piso mesopotámico de la formacion patagónica recogidos, en las barrancas del Paraná por el Profesor Pedro Scalabrini, 101.—L. Brackebusch. Viaje á la Provincia de-Jujuy, 185.

———. ———. ———. Tomo viii. Entrega 4a. 1886.

- Buenos Aires. Sociedad Científica Argentina. Anales. Tomo xxi.
Entregas 3 & 4. 1886.
- . ———. ———. Tomo xxii. Entregas 1-6. 1886.
P. N. Arata. Contribuciones al conocimiento higienico de la ciudad de Buenos Aires, 5.—J. J. J. Kyle. El oro del Cabo Virgenes, 75.
- . ———. ———. Tomo xxiii. Entregas 1 & 2. 1887.
J. Llerena. Un ensayo sobre la historia geológica de las Pampas Argentinas, 34.
- Calcutta. Asiatic Society of Bengal. Journal. N.S. Vol. liii.
Part 2. No. 4 (1884). 1887.
- . ———. ———. N. S. Vol. lv. Part 2. No. 1-3 (1886).
1886-87.
- . ———. Proceedings. Nos. 1-10 (1886). 1887.
- . ———. ———. No. 1 (1887). 1887.
- Cambridge, Mass. Museum of Comparative Zoology at Harvard
College. Annual Report for 1885-86. 1886.
- . ———. Bulletin. Vol. xii. Nos. 5 & 6. 1886.
- . ———. ———. Vol. xiii. Nos. 1 & 2. 1886.
- Cambridge Philosophical Society. Proceedings. Vol. v. Part 6.
1886.
H. Gadow. On some Caves in Portugal, 381.
- . ———. Proceedings. Vol. vi. Part 1. 1887.
O. Fisher. An attempt to explain certain Geological Phenomena by
the application to a liquid substratum of Henry's Law of Absorption of
Gases, 19.
- . ———. Transactions. Vol. xiv. Part 2. 1887.
- Carlisle. Cumberland and Westmoreland Association for the Ad-
vancement of Literature and Science. Transactions. No. 11
(1885-86). 1886.
J. Postlethwaite. The Mineral Springs near Keswick, 142.
- Catania. Accademia Gioenia di Scienze Naturali. Atti. Serie 3.
Tome xix. 1886.
L. Ricciardi. Ricerche chimiche sulle rocce vulcaniche dei dintorni
di Roma, 177.—A. Silvestri. Monografia chimica sulla sorgente dell'
acqua potabile detta Reitana presso Aci-Reale, 229.
- Chemical News. Nos. 1387-1415. 1886.
- . Nos. 1416-1438. 1887.
- Chemical Society. Abstracts of the Proceedings. Nos. 24-30.
1886.
- . ———. Nos. 31-39. 1887.
- . Journal. Nos. 284-289. 1886.
- . ———. Nos. 290-295. 1887.

- Chemical Society. Abstracts of the Proceedings. Supplementary Number (1886). Vols. xlix. & l. 1886.
- Chesterfield. Chesterfield and Midland Counties (late Chesterfield and Derbyshire) Institution of Engineers. Transactions. Vol. xiv. Part 2. 1885.
- Chicago Academy of Science. Bulletin. Vol. 1. No. 9. 1886.
Presented by Sir W. Dawson, F.R.S., F.G.S.
Sir W. Dawson. On Rhizocarps in the Erian (Devonian) Period in America, 105.
- Colliery Guardian. Nos. 1330–1357. 1886.
——. Nos. 1358–1381. 1887.
- Copenhagen. Kongelige Danske Videnskabernes Selskab. Naturvidenskabelige og Mathematiske Afhandlinger. Række vi. Bind 2. Nos. 8–11. 1885–86.
——. ———. Række vi. Bind 3. Nos. 2 & 4. 1885–86.
——. ———. Række vi. Bind 4. Nos. 1 & 3. 1886–87.
——. ———. Oversigt. 1885. No. 3. 1886.
——. ———. 1886. Nos. 1–3. 1886.
——. ———. 1887. No. 1. 1887.
- Cracow. Akademija Umiejetności w Krakowie. Sprawozdanie Komisji Fizyograficznej. Tomo xx. 1886.
A. M. Lomnicki. Stodkowodny utwór brzeziordny na Podoln galicyjskiem, Csesc II., 48.
- Darmstadt. Verein für Erdkunde zu Darmstadt, und Mittelrheinische geologische Verein. Notizblatt. 4 Folge. 6 Heft. 1885.
——. ———. 4 Folge. 7 Heft. 1886.
O. Böttger. Die altalluviale Molluskenfauna des Grossen Bruchs bei Traisa, Prov. Starkenburg, 1.—O. Böttger. Neue Paludinen aus dem Mainzer Becken, 7.
- Davenport Academy of Natural Sciences. Proceedings. Vol. iv. 1882–84. 1886.
C. Wachsmuth. On a new Genus and Species of Blastoids, with observations upon the Structure of the Basal Plates in *Codaster* and *Pentremites*, 76.—W. H. Harris. Descriptions of some new Blastoids from the Hamilton Group, 88.—C. Wachsmuth. Description of a new Crinoid from the Hamilton Group of Michigan, 95.—W. H. Harris. Descriptions of some new Crinoids from the Hamilton Group, 98.
- Dresden (Cassel). Königliches mineralogisch-geologisches und prähistorisches Museum in Dresden. Mittheilungen. Heft vii. (4to.) 1886. *Presented by Dr. H. B. Geinitz, F.M.G.S., Director.*
J. V. Deichmüller. Die Insecten aus dem lithographischen Schiefer im Dresdener Museum, 1.

Dresden. Naturwissenschaftliche Gesellschaft Isis. Sitzungsberichte und Abhandlungen, 1886. Jan.—Dec., 1886–87.

Abhandlungen.

F. E. Geinitz. Ueber einige Lausitzer Porphyre und Grünsteine sowie den Basalt aus dem Stolpener Schlossbrunnen, 13.—E. Danzig. Bemerkungen über das Diluvium innerhalb des Zittauer Quadergebirges, 30.—A. Purgold. Einige regelmässige Verwachsungen des Rothgiltenerzes, 53.—E. Danzig. Weitere Mittheilungen über die Granite und Gneisse der Oberlausitz und des angrenzenden Böhmens, 57.—J. V. Deichmüller. Die Meteoriten des königlichen mineralogischen Museums in Dresden, 92.

Dublin. Royal Geological Society of Ireland. Journal. Vol. xvii. (N. S. Vol. vii.) Part 1. 1886.

G. H. Kinahan. Notes on the Apatite of Buckingham, Ottawa County, 1.—G. H. Kinahan. Canadian Archæan, or Pre-Cambrian Rocks; with a Comparison with some of the Irish Metamorphic Rocks, 5.—G. H. Kinahan. Notes on the Coal Seams of the Leinster and Tipperary Coalfields, 20.—W. H. Baily. On Trilobites and other Fossils, from Lower or Cambro-Silurian Strata, in the County of Clare, 29.—W. J. Sollas. On the Physical Characters of Calcareous and Siliceous Sponge-Spicules and other Structures, 30.—V. Ball. On the newly discovered Sapphire Mines in the Himalayas, 49.—B. H. Mullen. On a set of Musical Stones in the Science and Art Museum, Dublin, 52.—W. J. Sollas. On a Hexactinellid Sponge from the Gault, and a Lithistid from the Lias of England, 57.—J. P. O'Reilly. On De Rossi's Seismical and Endodynamical Map of Italy, 61.—J. P. O'Reilly. On the Occurrence of Beryl with Schorl in Glencullen Valley, 69.—W. H. Baily. On a New Species of *Orophocrinus* (Pentremites) in Carboniferous Limestone, Co. Dublin, also Remarks upon *Codaster trilobatus* (McCoy) from Carboniferous Limestones, Co. Kilkenney, 71.—E. Hull. On the Occurrence of an Outlying Mass of Supposed Lower Old Red Sandstone and Conglomerate in the Promontory of Fanad, County Donegal, 74.

———. ———. ———. Vol. xviii. (N. S. Vol. viii.) Part 1. 1887.

G. H. Kinahan. Economic Geology of Ireland, 1.

———. Royal Irish Academy. Cunningham Memoirs. Nos. 2. and 3. 1886. (4to.)

———. ———. Proceedings. Ser. 2. Vol. ii. No. 7. Polite Literature and Antiquities. 1886.

W. J. Knowles. Flint Implements from the North-east of Ireland, 436.

———. ———. ———. Ser. 2. Vol. iv. No. 5. Science. 1886.

———. ———. Transactions. Vol. xxvii. Polite Literature and Antiquities. Parts 6–8. 1885–86.

———. ———. ———. Vol. xxviii. Science. Parts 11–25. 1885–1886.

J. P. O'Reilly. Alphabetical Catalogue of the Earthquakes recorded as having occurred in Europe and adjacent Countries, arranged to serve as a basis for an Earthquake Map of Europe, 489.

East-India Association. Journal. Vol. xviii. No. 5 & 6. 1886.

———. ———. Vol. xix. Nos. 1-4. 1887.

Edinburgh. Geological Society. Transactions. Sessions 1884-85, 1885-86. Vol. v. Part 2. 1887.

D. Milne-Home. Inaugural Address, 1884-85, 171.—R. Richardson. Report on the Montreal Meeting of the British Association, 181.—G. Lindström. Preliminary Notice on a Silurian Scorpion (*Palæophonus nuncius*, Torell and Lindström), from the Isle of Gothland, 184.—J. R. S. Hunter. Notes on a new Fossil Scorpion (*Palæophonus caledonicus*), from the Upper Silurian Shales, Logan Water, Lesmahagow, 187.—W. Ferguson. Notices of some Iron Ore Deposits in Aberdeenshire and Banffshire, 192.—J. Reid. Notes on the Origin and Development of Granitic and other allied Varieties of Crystalline Rocks, 199.—R. Richardson. On Canadian and Scottish Glacial Geology, 205.—R. Richardson. Notice of "The Gled Stane" and other Boulders near Pitlochry, Perthshire, 213.—W. T. Kinnear. On the Occurrence and Range of Beds containing Scorpion remains in the Carboniferous Rocks of Fife, 216.—G. H. Kinahan. The Terraces of the Great American Lakes and the Roads of Glenroy, 221.—T. D. Wallace. The Geology of the Parish of Kirkhill and the "Aird," Inverness-shire, 224.—W. Morrison. Precambrian Conglomerate of Lewis, 235.—R. Richardson. Closing Address, Session 1884-85, 243.—R. Richardson. Inaugural Address, Session 1885-86, 249.—J. Melvin. On the Parallel Roads of Lochaber, 268.—W. Morrison. Terraces at Achnasheen, 275.—W. Anderson. Note on the Occurrence of a new Species of Carboniferous Crustacean at Ardross, near Elie, Fife, 280.—A. Johnstone. On the Action of Carbonic Acid Water on Minerals and Rocks, 282.—H. Rink. Results of the Recent Danish Explorations in Greenland, with regard to the Inland Ice (1876 to 1884), 286.—J. Simpson. On Reindeer and other Mammalian Bones discovered by Mr. Macfie of Dreghorn in a Rock-fissure at Green Craig, Pentland Hills, 294.—J. Henderson. On Reindeer and other Mammalian Remains from the Pentland Hills, 302.—W. J. Macadam. Exhibition of, and notes on, Specimens of Red-deer Horns from the Sand Deposits at the Mouth of the Nith, Dumfriesshire, 305.—Romanis. Notes on Upper Burma, 306.—A. Somervail. Notes on the Archæan Gneiss of Ross and Sutherland, 307.—W. Anderson. Notes on the Fish Remains from the Bone Bed at Abden, near Kinghorn, Fife, with remarks by Dr. R. H. Traquair, 310.—W. J. Macadam. Notice of a new Fossiliferous Bed in the Island of Arran, 316.—J. S. G. Wilson and W. J. Macadam. Diatomaceous Deposits in Skye, 318.—D. Cameron. Geological Observations on Easter Ross, Moy and Craggie, and Athole, 330.—D. Cameron. The Geology of Fearn and Tarbat, 330.—A. M'Charles. Notes on the Geology of the Winnipeg District, Manitoba, 331.

———. Royal Physical Society. Proceedings. Session 1885-86. 1886.

B. N. Peach. Opening Address by the President, 1.—R. Kidston. On the Species of the Genus *Palæoxyris*, Brongniart, occurring in British Carboniferous Rocks, 54.—James Rennie and R. Kidston. On the Occurrence of Spores in the Carboniferous Formation of Scotland, 82.

Ekaterinburg. Société Ouralienne d'Amateurs des Sciences Naturelles. Bulletin (4to). Tome iv. 1876.

———. ———. ———. Tome v. Nos. 1-3 (1879-80). 1879-80.

V. M. Malakhoff. Indicateur des lieux de provenance des minéraux

connus jusqu'ici dans les monts Ourals, 1.—N. Brousnitsyne. La psychma en aval du village de Mokraia jusqu'à la ville de Kamyschloff, 11.—A. J. Drezdoff. Les eaux minérales de Kourii et d'Alapævsk, 25.

Ekaterinburg. Société Ouralienne d'Amateurs des Sciences Naturelles. Bulletin (4to). Tome vi. Nos. 1-3 (1880-82). 1880-82.

N. N. Novokréstchennykh. L'usine de Kizel, 43.—V. M. Malakhoff. Indicateur des lieux de provenance des minéraux connus jusqu'ici dans les monts Ourals, 55.—A. J. Drezdoff. Composition chimique des charbons fossiles du versant est des monts Ourals, 63.

———. ———. ———. Tome vii. Nos. 1-4 (1881-84). 1881-84.

A. J. Drezdoff. Matériaux touchant les eaux minérales de l'Oural, 1, 7.—M. H. Trautschold. Traces de l'étage Tongrien près de Kamyschloff, 21.—A. P. Karpinski. Sédiments tertiaires du versant oriental de l'Oural, 60.—J. N. Ochtchepkoff. Qui a découvert le diamant dans les monts Ourals?, 87.

———. ———. ———. Tome viii. No. 1 (1885). 1885.

———. ———. ———. Tome ix. No. 1 (1885). 1885.

Frankfort-on-the-Maine. Senckenbergische naturforschende Gesellschaft. Bericht, 1886. 1886.

F. Kinkelin. Der Meeressand von Waldböckelheim, 135.

Geneva. Société Géologique Suisse. Compte rendu de la cinquième réunion annuelle en Août 1886 à Genève. (8vo.) 1886.

Geological Magazine. Dec. iii. Vol. iii. Nos. 7-12. 1886.

H. A. Nilcholson. On *Desmidopora alveolaris*, Mich., a new genus and species of Silurian Corals, 289.—R. S. Oldham. Essays on Speculative Geology. I. On Homotaxis and Contemporaneity, 293. II. Probable Changes of Latitude, 300.—W. Downes. On the Tunnel Section near Honiton, Devon, 308.—A. J. Jukes-Browne. On the Application of the term Neocomian, 311.—C. Lapworth. On the Sequence and Systematic Position of the Cambrian Rocks of Nuneaton, 319.—T. H. Waller. Preliminary Note on the Volcanic and Associated Rocks of the Neighbourhood of Nuneaton, 322.—G. J. Hinde. Note on *Eophyton*? *explanatum*, Hicks, and on *Hyalostelia* (*Pyritonema*) *fasciculus*, M'Coy, sp., 337.—P. M. Duncan. On a new Species of *Axosmia* (*A. elongata*), from the Pea Grit of the Inferior Oolite of England, 340.—J. S. Gardner. Mesozoic Angiosperms, 342.—J. J. H. Teall. Notes on some Hornblende-bearing Rocks from the Inchnadampf, 346.—A. Irving. The Brookwood Deep Well Section, 353.—J. R. Gregory. The Bois de Fontaine Meteorite, and its probable identity with that of Charsonville of 1810, 357.—J. H. Collins. On the Geological History of the Cornish Serpentinous Rocks, 359.—R. F. Tomes. On some new or imperfectly known Madreporaria from the Inferior Oolite of Oxfordshire, Gloucestershire, and Dorsetshire, 385, 443.—R. Etheridge, jun. Note on the Recent Volcanic Eruption in New Zealand, 398.—A. Irving. The Unconformity between the Bagshot Beds and the London Clay, 402.—S. A. Adamson. Notes on the Discovery of the base of a Large Fossil Tree at Clayton, 406.—T. Rupert Jones and J. W. Kirkby. On some Fringed and other Ostracoda from the Carboniferous Series, 433.—R. H. Traquair. New Palæoniscidæ from the English Coal-measures, 440.—S. S. Buckman. On the Lobe-line of certain Species of Lias Ammonites described in the Monograph by the

late Dr. Wright, 442.—W. J. Harrison. On a Deep Boring in the New Red Marls (Keuper Marls) near Birmingham, 453.—T. Rupert Jones. On Palæozoic Phyllopora, 456.—J. J. H. Teall. The Metamorphosis of the Lizard Gabbros, 451.—T. McK. Hughes. On the Ffynnon Beuno Caves, 489.—A. B. Wynne. On the faceted and striated pebble from the Olive Group Conglomerate of Chiel Hill in the Salt Range of the Punjab, India, 492.—W. T. Blanford. Notes on a smoothed and striated Boulder from a Deposit in the Pretertiary Punjab Salt Range, 494.—J. S. Gardner. On Fossil flowering or phanerogamous Plants, 495.—British Association, 1886. Section C. Geology, 503.—E. Wethered. On the Structure and Organisms of the Lower Limestone Shales, Carboniferous Limestone, and Upper Limestones of the Forest of Dean, 529.—A. Strahan. On the Rocks surrounding the Warwickshire Coalfield, and on the Base of the Coal-measures, 540.—F. Rutley. The Igneous Rocks, etc., of the Neighbourhood of the Warwickshire Coal-field, 557.—G. Sharman. On the new Species *Olenus nuneatonensis* and *Obolella granulata*, from the Lower Silurian ('Cambrian') Lapworth near Nuneaton, 565.—H. Hicks. On the Ffynnon Beuno and Cae Gwyn Caves, 566.

Geological Magazine. Dec. iii. Vol. iii. Nos. 7-12. 1886.

Purchased.

——. ——. Vol. iv. Nos. 1-6. 1887.

H. Woodward. On some Spined Myriapods from the Carboniferous Series of England, 1.—W. A. E. Ussher. The Culm-Measures of Devonshire, 10.—W. S. Gresley. Notes on "Cone-in-Cone" Structure, 17.—H. C. Lewis. On a Diamantiferous Peridotite, and the Genesis of the Diamond, 22.—A. J. Jukes-Browne. Note on a Bed of Red Chalk in the Lower Chalk of Suffolk, 24.—H. C. Lewis. Comparative Studies upon the Glaciation of North America, Great Britain, and Ireland, 28.—R. D. Oldham. Note on the faceted Pebbles from the Olive Group of the Salt Range, Punjab, India, 32.—J. E. Marr. The Lower Palæozoic Rocks near Settle, 35.—British Association, 1886. Section C. Geology, 38, 117.—H. Woodward. Some new British Carboniferous Coleoptera, 49.—E. Hill. In Brittany with the Geological Society of France, 59.—T. G. Bonney. Note on Specimens of the Rauenthal Serpentine, 65.—H. Keeping. On the discovery of the *Nummulina-elegans* Zone at Whitecliff Bay, Isle of Wight, 70.—A. J. Jukes-Browne and W. Hill. Note on the Gault and Chalk-marl of West Norfolk, 72.—C. A. McMahon. Note on the Foliation of the Lizard Gabbro, 74.—T. Wright (the later). On a new *Ophiurella*, 97.—R. F. Tomes. On two Species of Palæozoic Madreporaria hitherto not recognized as British, 98.—A. Smith Woodward. Notes on some Post-Liassic Species of *Acrodus*, 101.—H. Hicks. The Faunas of the Ffynnon Beuno Caves and of the Norfolk Forest Bed, 105.—J. S. Gardner. On the Beds containing the Gelinden Flora, 107.—G. F. Harris. On the Gelinden Beds &c., 108.—A. Irving. An Outlier of Upper Bagshot Sands on London Clay, 111.—H. Woodward. Supplementary note on *Euphoberia ferox*, Salter, 116.—E. T. Newton. Note on some recent additions to the Vertebrate Fauna of the Norfolk "Pre-Glacial Forest-Bed," 145.—A. J. Jukes-Browne. Inter-Glacial Land-surfaces in England and Wales, 147.—J. E. Marr. The Work of Ice-sheets, 151.—H. Hicks. The Cambrian Rocks of North America, 155.—J. S. Gardner. The appearance and development of Dicotyledons in Time, 158.—J. W. Spencer. Notes on the Erosive Power of Glaciers as seen in Norway, 167.—H. A. Nicholson. On *Hemiphyllum sibiricense*, Tomes, 173.—E. Wilson. British Liassic Gasteropoda, 193, 258.—G.

Dowker. The Water-supply of East Kent, in connection with Natural Springs and Deep Wells, 202.—C. A. McMahon. The Gneissose Granite of the Himalayas, 212.—J. H. Collins. On the Geological History of the Cornish Serpentinous Rocks, 220.—O. C. Marsh. American Jurassic Mammals, 241.—R. H. Traquair. Notes on *Chondrosteus acipenseroides*, Agassiz, 248.—J. E. Marr. The Glacial Deposits of Sudbury, Suffolk, 262.—R. Lydekker and G. A. Boulenger. Notes on Chelonia from the Purbeck, Wealden, and London-clay, 270.

Geological Magazine. Dec. iii. Vol. iv. Nos. 1-6. 1887. *Purchased.*

Geologists' Association. Proceedings. Vol. ix. Nos. 6 & 7. 1886.

W. Topley. The Life and Work of Professor John Morris, M.A., F.G.S., 386.—A. Irving. The Stratigraphical Relations of the Bagshot Sands of the London Basin to the London Clay, 411.—J. Johnston-Lavis. On the Fragmentary Ejectamenta of Volcanoes, 421.—J. Starkie Gardner. Fossil Grasses, 433.—J. Postlethwaite and J. G. Goodchild. On some Trilobites from the Skiddaw Slates, 469.—J. G. Goodchild. Observations upon the Stratigraphical Relations of the Skiddaw Slates, 462.—G. S. Boulger. On the Connection in Time of changes in Fossil Floras with those of Faunas, 482.—T. Rupert Jones and J. W. Kirkby. A List of the Genera and Species of Bivalved Entomostraca found in the Carboniferous Formations of Great Britain and Ireland, with notes on the Genera and their Distribution, 495.

———. ———. Vol. x. No. 1. 1887.

A. Smith Woodward. On "Leathery Turtles," Recent and Fossil, and their Occurrence in British Eocene deposits, 2.—H. Hicks. On some further Researches in Bone-caves in North Wales, 14.—P. H. Carpenter. On Crinoids and Blastoids, 19.

Glasgow. Geological Society. Transactions. Vol. viii. Part 1 (1883-84, 1884-85). 1886.

J. Young. Notes on Cone-in-Cone Structure, 1.—R. Craig. On the Upper Limestones of North Ayrshire, as found in the district around Dalry, and elsewhere, 28.—W. Jolly. The Parallel Roads of Lochaber: the Problem, its Conditions and Solutions, 40.—R. Kidston. Notes on some Fossil Plants collected by Mr. R. Dunlop, Airdrie, from the Lanarkshire Coal-field, 47.—W. Jolly. Excursion to Ben Nevis and the Parallel Roads of Lochaber, 72.—J. White. A Glimpse of Skye; with Remarks on Volcanic Action, 105.—J. White. Notes on Tarbert, Argyllshire, 111.—D. Bell. Notes on the Geology of Oban, 116.—J. Young. Notes on the Cathkin "Osmund Stone," a Volcanic Tuff, 134.—J. Young. Notice of the late Dr. Thomas Davidson, 138.—J. Young. Notes on the Carboniferous Brachiopoda, with Revised List of the Genera and Species, 143.—J. R. S. Hunter. The Old Red Sandstone of Lanarkshire, with notes on Volcanic Action during Old Red and Carboniferous Times, 161.—J. R. S. Hunter. Notes on the Discovery of a Fossil Scorpion (*Palaeophonus caledonicus*) in the Silurian Strata of Logan Water, 162.—J. Thomson. The Geology of the Territory of Idaho, U.S., and the Silver Lode of Atlanta, 173.—J. B. Murdoch. Notes on the Principal Geological Papers read at the British Association Meeting, Aberdeen, 1885. 179.

Gloucester. Cotteswold Naturalists' Field Club. Proceedings for 1885-86. 1887.

Sir W. V. Guise. Annual Address of the President, 1.—E. Witchell.

On the Genus *Nerinea*, and its Stratigraphical Distribution in the Cotteswolds, 21.—S. S. Buckman. Some new Species of Brachiopoda from the Inferior Oolite of the Cotteswolds, 38.—J. H. Taunton. Some Notes on the Hydrology of the Cotteswolds and the district around Swindon, 52.—J. H. Taunton. A Visit to the Boxwell Springs, July 1886, 70.—E. Wethered. *Mitcheldeania Nicholsoni*, a new Genus, from the Lower Carboniferous Shales of the Forest of Dean, 77.

Haarlem. Hollandsche Maatschappij der Wetenschappen. (Société Hollandaise des Sciences.) Natuurkundige Verhandelingen. 3de Verz. Deel iv. No. 4. 1887.

———. Archives Néerlandaises des Sciences Exactes et Naturelles. Tome xx. Livr. 5. 1886.

———. ———. Tome xxi. Livr. 1-4. 1886-87.

J. Bosscha, fils. Sur la météorite de Karang-Modjo, ou Magetan, 177.

Halifax. Yorkskire Geological and Polytechnic Society. Proceedings. N. S. Vol. ix. Part 2. Pp. 145-336. 1887.

H. B. Stocks. On a Concretion called Acrospire, 149.—J. Magens Mello. On the Microscopical Structure of Rocks, 151.—W. Horne. On Prehistoric Remains recently discovered in Wensleydale, 175.—G. R. Vine. Notes on the Polyzoa of the Wenlock Shales &c., 179.—J. W. Davis. On the Relative Age of the Remains of Man in Yorkshire, 201.—J. R. Mortimer. On the Habitation Terraces of the East Riding, 221.—G. R. Vine. Notes on the Palæontology of the Wenlock Shales of Shropshire, 224.—J. W. Davis. On some Remains of Fossil Trees in the Lower Coal-measures at Clayton, near Halifax, 253.—J. S. Tute. On the Cayton Gill Beds, 265.—J. W. Davis. On the Exploration of the Raygill Fissure in Lothersdale, 280.—S. A. Adamson. On the Discovery of a Stone Implement in Alluvial Gravels at Barnsley, 281.

Halifax, N. S. Nova Scotian Institute of Natural Science. Proceedings and Transactions. Vol. vi. Part 4 (1885-86). 1886.

D. Honeyman. Additional Notes on Glacial Action in Halifax Harbour, 251.—E. Gilpin. The Carboniferous of Cape Breton, 289.—D. Honeyman. A Revision of the Geology of Antigonish County, 308.

Halle. Academia Cæsareo-Leopoldina Naturæ Curiosorum. Nova Acta. Tomus xlvii. 1885.

———. ———. ———. Tomus xlviii. 1886.

H. Engelhardt. Die Tertiärflora des Jesuitengrabens bei Kundralitz in Nordböhmen, 297.

Halle. Zeitschrift für Naturwissenschaften. Band lviii. Heft 2-6. 1885.

P. Lüdecke. Datolith von Casarza, 276.—P. Lüdecke. Calciumoxydhydrat als Kesselstein, 282.—P. Lüdecke. Beobachtungen an Stassfurter Vorkommnissen (Pinnoit, Pikromerit, Kainit und Steinsalz), 645.

- Halle. Zeitschrift für Naturwissenschaften. Band lix. Heft 1. 1886.
- O. Burbach. Beiträge zur Kenntniss der Foraminiferen des mittleren Lias am grossen Seeberg bei Gotha, 30.
- Hamilton, Canada. Hamilton Association. Journal and Proceedings, 1884–85. Vol. i. Part 2. 1885. 8vo.
- J. W. Spencer. Remarkable Landslide near Brantford, Ontario, 55.
- Havre. Société Géologique de Normandie. Bulletin. Tome x. (1883–84.) 1885.
- P. Bizet. Note explicative sur le profil géologique de la route de Verneuil à Alençon, 44.—G. Lionnet. Réunion à Cherbourg, 53.—G. Lionnet. Sur la présence du terrain crétacé inférieur dans les falaises de la Hève, 71.
- Hertford. Hertfordshire Natural-History Society and Field-Club. Vol. iv. Parts 1–5. 1886–87.
- R. Meldola. The Great Essex Earthquake of the 22nd of April, 1884, 23.
- Hobart Town. Royal Society of Tasmania. Papers and Proceedings for 1886. 1887.
- F. W. Hutton. On the Geology of the New-Zealand Alps, 1.—R. M. Johnston. Contributions to the Palæontology of the Upper Palæozoic Rocks of Tasmania, 4.—R. M. Johnston. Notes on the Geology of Bruny Island, 18.—R. M. Johnston. Reference-List of the Tertiary Fossils of Tasmania, 124.—C. P. Sprent. Antarctic Exploration, 141.—R. M. Johnston. Remarks regarding Coal-seam opened out by Mr. Brock at Compton, Old Beach, 155.—R. M. Johnston. Remarks on the Longford Coal-Basin, 156.—R. M. Johnston. Fresh Contribution to our Knowledge of the Plants of Mesozoic Age in Tasmania, 160.—Baron von Groddeck. On the Tin-Ore Deposits of Mount Bischoff, Tasmania, 189.—R. M. Johnston. Notes on the Geology of the King River, together with a brief account of the History of Gold-mining in Australia, 210.—R. M. Johnston. Notes and Descriptions of Crinoidea from the Upper Palæozoic Rocks of Tasmania, 231.—S. H. Wintle. Notes on Fossil Crabs from the deep dredgings of the Yarra River, and excavation of the Coode Canal, Victoria, 233.
- Industrial Review. N. S. Nos. 27–34. 1887.
- J. Barwise. Subterranean Movements, 418.—F. A. Hill. Geology and Mining in the Northern Coal-field of Pennsylvania, 426.—A. Bowman. Mineral Wealth of British Columbia, 421, 435.—Great Mother-Lode in Amador County, 468.—T. A. Readwin. Mineralogy, 468, 484, 531.—T. A. Readwin. Gold in Wales, 515.—E. S. Moffat. Present Growth of Coal, 533.—Glacial Period and Man, 534.
- Institution of Civil Engineers. Minutes of Proceedings. Vol. lxxxv. 1886.
- J. T. Manby. The Granada Earthquake of 25th December, 1884, 274.
- . ———. Vol. lxxxvi. 1886.
- S. H. Farrar. Note on the Gold-fields of South Africa, 343.

- Institution of Civil Engineers. Minutes of Proceedings. Vol. lxxxvii. 1886.
- . ———. Vol. lxxxviii. 1887.
- . ———. Brief Subject-Index. Vols. lix.—lxxxvi. Sessions 1879–80 to 1885–86. 1886.
- Kingston Queen's College and University, Kingston, Canada. Calendar for the Year 1886–87. 1886.
- Lausanne. Société Vaudoise des Sciences Naturelles. Bulletin. Série 3. Vol. xxii. No. 94. 1886.
- E. Renevier. Résultats scientifiques du congrès géologique international de Berlin, 54.—E. Renevier. Le Musée géologique de Lausanne en 1885, 75.
- . ———. ———. ———. ———. No. 95. 1887.
- R. Häusler. Notes sur quelques foraminifères des marnes à bryozoaires du Valangien de Ste-Croix, 260.
- Leeds. Geological Association. Transactions, 1885–86. Part 2. 1886.
- B. Holgate. The Leeds Lower Coal-measures, 49.—H. H. French. On "Bournes," 51.—J. Stubbins. On Foraminifera, 53.—Monckman. The Volcanic History of England, 56.—J. Spencer. The Evolution and Distribution of the Ancient Floras of the Earth, 58.—B. Holgate. Notes on the Geology of Bournemouth, 61.—C. D. Hardcastle. On Metamorphic Rocks, 62.—A. H. Green. The Drift of the North of England, 64.—C. D. Hardcastle. Presidential Address, 66.—B. Holgate. Surface Indications, a guide to the Geology of a District, 69.—S. A. Adamson. Recent Discoveries of Carboniferous Vegetation in Yorkshire, 71.—S. A. Adamson. Reports of Field Excursions, 77.
- . Naturalists' Club and Scientific Association. Transactions, 1886. 1886.
- Leicester. Literary and Philosophical Society. Report of the Council and Reports of the Sections (1885–86). 1886.
- . ———. Transactions. (New Quarterly Series.) Part 1 (1886). 1886.
- E. F. Bates and L. Hodges. Notes on a recent Exposure of the Lower Lias and Rhætics in the Spinney Hills, Leicester, 22.
- . ———. ———. (———). Part 2 (1887). 1887.
- C. A. Moore. The Influence of the Geological Features of a District on the Health of its Inhabitants, 20.
- Leipzig. Naturforschende Gesellschaft. Sitzungsberichte. 12 Jahrgang, 1885. 1886.
- J. Felix. Strukturzeigende Pflanzenreste aus der oberen Steinkohlen-Formation Westphalens, 7.—A. Sauer und F. Schalch. Ein neues Mineral aus dem Granulite bei Waldheim, 27.
- . Zeitschrift für Krystallographie und Mineralogie. Band xi. Hefte 5 & 6. 1886. *Purchased.*
- G. Flink. Studien über schwedische Pyroxenminerale, 449.—C. Schmidt. Beiträge zur Kenntniss der Skolezit, 587.—C. Schmidt. Albit aus dem Sericit-Gestein von Eppenhain im Taunus, 597.—C.

Schmidt. Ueber die Mineralien des Eisenoolithes an der Windgällen im Canton Uri, 597.—A. Des Cloizeaux. Neue Flächen am Orthoklas von Elba, 605.—C. Hintze. Regelmässige Verwachsung von Bournonit mit Bleiglanz, 606.—C. Hintze. Ueber Arsenolamprit, 606.—J. Lehmann. Contractionsrisse, 608.

Leipzig. Zeitschrift für Krystallographie und Mineralogie. Band xii. Hefte 1-6. 1886. *Purchased.*

R. Scharizer. Ueber den Zwillingsbau des Lepidolithes und die regelmässige Verwachsung verschiedener Glimmerarten von Schüttenhofen, 1.—H. Baumhauer. Ueber die Structur und die mikroskopische Beschaffenheit von Speiskobalt und Chloanthit, 18.—A. Cathrein. Ueber Mineralien von Predazzo, 34.—A. Cathrein. Verwachsung von Ilmenit mit Magnetit, 40.—A. Cathrein. Zwillingsstreifung am Magnetit, 47.—A. Gehmacher. Die Krystallform des Pfitscher Zirkons, 50.—C. Schmidt. Mittheilungen über ungarische Mineralvorkommen, 97.—M. Schuster. Ueber hemimorphe Pyrrargyritzwillinge von Andreasberg, 117.—A. Des Cloizeaux. Ueber das Krystallsystem des Descloizit, 178.—C. S. Bement. Ueber neuere amerikanische Mineralvorkommen, 179.—F. Pfaff. Hartecurve der Zinkblende auf der Dodekäderfläche, 180.—W. Ramsay. Methode zur Bestimmung der Brechungsexponenten in Prismen mit grossen brechenden Winkeln, 209.—A. Becker. Ueber die chemische Zusammensetzung des Barytocalcits und des Alstonits, 222.—C. Bärwald. Untersuchung einiger Cölestine, 229.—A. Brand. Ueber Krystalle aus dem Gestübbe der Bleiöfen in Mechernich, welche dem Mineral Breithauptit entsprechen, 234.—J. Hockauf. Ueber Botryogen, 240.—R. Scharizer. Der Monazit von Schüttenhofen, 255.—E. S. Dana. Ueber den Columbit, 267.—E. S. Dana. Zur Krystallisation des Goldes, 275.—K. Öbbeke. Ueber das Vorkommen des Glaukophan, 282.—H. Bücking. Topas von San Louis Potosi und von Durango, 424, 451.—F. Feist. Topas vom Ilmengebirge, 434.—R. Riechelmann. Datolith von der Seisser Alp, 436.—T. Liweh. Cölestin von Lunenburg, 439.—G. Vom Rath. Einige neue und seltene Flächen an Quarzen aus der Sammlung des Herrn W. C. Hidden, 453.—E. S. Dana. Mineralogische Notizen, 459.—E. Hussak. Ein Beitrag zur Kenntniss der optischen Anomalien am Flusspath, 553.—E. S. Dana. Ueber die Krystallisation des gediegenen Kupfers, 569.—A. Knop. Beiträge zur Kenntniss einiger Glieder der Glimmerfamilie, 588.—A. Knop. Ueber Pseudobiotit, 607.—A. Knop. Ueber krystallisirte Niobsäure, 610.

———. ———. Band xiii. Heft 1. 1887. *Purchased.*

G. Flink. Ueber Långbanit, ein neues Mineral von Långbaushyttan in Wermland, Schweden, 1.—A. Cathrein. Ueber die Hornblende von Roda, 9.—R. Scharizer. Ueber den Xenotim und über eine neue Glimmersverwachsung von Schüttenhofen, 15.—J. Beckenkamp. Baryt von Oberschaffhausen im Kaiserstuhl, 25.—V. von Zepharovich. Neue Pyroxenfunde in den Salzburger Alpen, 45.—C. S. Bement. Ueber neuere amerikanische Mineralvorkommen, 46.—H. Mayer. Kupferkies von Holzheim in Nassau, 47.

Leyden. Geologische Reichs-Museum. Sammlungen. Ser. 2. No. 1. 1887. *Purchased.*

J. H. Kloss. Untersuchungen über Gesteine und Mineralien aus West-Indien, 1.—J. Lorié. Fossile Mollusken von Curaçao, Aruba und der Küste von Venezuela, 111.—M. Schepman. Bijdrage tot de kennis der Molluskenfauna van de Schelpritsen van Suriname, 150.

Liège. Société Géologique de Belgique. Procès-Verbal de l'Assemblée Générale du 21 Novembre, 1886. (8vo.) 1887.

———. Société Royale des Sciences. Mémoires. Sér. 2. Tome xiii. 1886.

Lille. Société Géologique du Nord. Annales. Tome xiii. (1885-86). Livr. 4-6. 1886.

A. Six. Les procédés opératoires de microchimie en histologie minérale, 206.—C. Jannel. Ligne de Gretz à Esternay, 245.—A. Six. Le glaciaire paléozoïque et l'âge des houilles de l'Inde et d'Australie d'après le Dr. W. T. Blanford, 256.—J. Ladrière. La terrain quaternaire de la vallée de la Deûle à Lille, comparé à celui du Nord de la France, 266.—J. Ladrière. Note sur l'existence de la tourbe quaternaire à La Flamengries-lez-Bavai, 288.—J. Gosselet. Tableau de la faune coblenzienne, 292.—J. Gosselet. Note sur les roches draguées au large d'Ostende, 310.—J. Hall. Les Lamellibranches dévoniens de l'état de New York, 311.—J. Gronnier. Compte-rendu de l'excursion de la Société Géologique du Nord du 4 Juillet 1886, 320.—Paulin-Arrault. Sondage au lieu dit le Petit-Château près de l'Etablissement des Boues à Saint-Amand, 329.—Manouvriez. Documents concernant les eaux sulfureuses du Nord, 330.—Manouvriez. Documents concernant les eaux salées du Nord, 331.

———. ———. ———. Tome xiv. (1886-87). Livr. 1. 1887.

J. Gronnier. Note géologique sur le Vermandois, 1.—E. Canu. Sur les ossements trouvés par M. Grégoire dans l'Aachénien de Rocq.—Recquignies, 20.—E. Delecroix. Note sur l'altération des eaux d'un puits en Angleterre, 22.—C. Barrois. Sur le Kersanton de la Rade de Brest, 31.

Linnean Society. Journal. Zoology. Vol. xix. Nos. 114 & 115. 1886.

———. ———. ———. Vol. xx. No. 116. 1886.

P. M. Duncan. On the Anatomy of the Perignathic Girdle and of other parts of the Test of *Discoidea cylindrica*, Lamarck, sp., 48.

———. ———. ———. Vol. xxi. Nos. 126-128. 1886.

———. ———. Botany. Vol. xxii. Nos. 145-148. 1886 & 1887.

J. S. Gardner. Remarks on some Fossil Leaves from the Isle of Mull (Scotland), 219.

———. ———. ———. Vol. xxiii. No. 151. 1886.

———. Transactions. Ser. 2. Zoology. Vol. ii. Parts 12, 15-17. 1885-86.

———. ———. ———. ———. Vol. iii. Part 4. 1885.

Lisbon. Sociedade de Geographia. Boletim. Serie 6. Nos. 1 & 2. 1886.

———. ———. ———. Serie 6. Nos. 4-11. 1886.

J. C. Lang. O petroleo do Dande, 240.

Liverpool Geological Society. Proceedings. 1885-86. Vol. v. Part 2. 1886.

T. M. Reade. The North Atlantic as a Geological Basin, 14.—C. Ricketts. The Occurrence of Bitumen in the Palæozoic Rocks of Shrop-

shire, 131.—H. C. Beasley. On a Section of the Upper Keuper at Oxton, 134.—T. M. Reade. Notes on a Bed of Freshwater Shells and a Chipped Flint from the Alt Mouth, 137.—O. W. Jeffs. On the Occurrence of Copper in the Keuper of Peckforton Hills, 139.—W. Hewitt. Notes on the Topography of Liverpool, 145.—T. M. Reade. Boulders wedged in the Falls of the Cynfael, 155.—T. M. Reade. On a Section of the Trias at Vyrnwy Street, Everton, displaying evidence of Lateral Pressure, 158.—A. N. Tate. The Origin of Petroleum and other Natural Hydrocarbons, 160.—C. Ricketts. Impressions of Footprints and Plants from the Trias of Oxton Heath, 168.—G. H. Morton. The Carboniferous Limestone and Cefn-y-Fedw Sandstone of Flintshire, 169.

Liverpool. Literary and Philosophical Society. Proceedings, 1884–1885. Vol. xxxix. 1885.

R. J. H. Gibson. The Relationship of Palæontology to Biology, 105.

———. ———. ———, 1885–86. Vol. xl. 1886.

London, Edinburgh, and Dublin Philosophical Magazine and Journal of Science. Ser. 5. Vol. xxii. Nos. 134–139. 1886. *Presented by Dr. W. Francis, F.G.S.*

H. Hennessy. On the Physical Structure of the Earth, 233.—H. Hennessy. Note on the Annual Precession calculated on the Hypothesis of the Earth's Solidity, 328.

———. ———. Vol. xxiii. Nos. 140–145. 1887. *Presented by Dr. W. Francis, F.G.S.*

O. Fisher. On the Amount of the Elevations attributable to Compression through the Contraction during Cooling of a Solid Earth, 145.

London Iron Trades Exchange. Nos. 1412–1437. 1886.

———. Nos. 1438–1462. 1887.

Lyon. Muséum d'Histoire Naturelle. Archives. Tome vi. 1887. *Purchased.*

F. Fontannes. Les Terrains Tertiaires et Quaternaires du Promontoire de la Croix-Rousse, à Lyon, 27.

Madrid. Real Academia de Ciencias Exactas, Físicas y Naturales. Memorias. Tomo xi. 1887.

———. ———. Revista de los Progresos de los Ciencias Exactas, Físicas y Naturales. Tomo xxi. Nos. 7–9. 1886.

———. ———. ———. Tomo xxii. Nos. 1–3. 1886–87.

M. Meringo. Los terremotos experimentados en la Liguria, y alta Suiza, y occidente y mediodía de Francia, 196.

———. Sociedad Española de Geografía Comercial. Revista de Geografía Comercial. No. 25 á 30. 1886. (4to.)

F. Quiroga. Estructura de la Peninsula de Rio de Oro, 8.—F. Quiroga. Estructura y formación del Sahara occidental, 63.—F. Quiroga. Colecciones del Sáhara y de Canarias, 72.

Manchester. Geological Society. Transactions. Vol. xviii. Part 20. 1886.

W. Boyd Dawkins. On the Formation of Agates, 525.

———. ———. ———. Vol. xix. Parts 1–7. 1887.

W. B. Dawkins. On the Geography of Britain in the Carboniferous Period, 37.—W. Watts. Geological Sketches at Piethorn and Denshaw, 47.—R. T. Burnett. The Question of the Pre-Atlantic Land, 79.—G. H. Kinahan. The Extent of the Carboniferous Sea as regards Ireland, 114.—P. F. Kendall. The Carboniferous Volcanoes of Great Britain, 133.—T. Ward. On the Subsidences in the Salt Districts of Cheshire, their History and Cause, 152.

Melbourne. Geological Society of Australasia. Transactions. Vol. i. Part 1. 1886. (Small 4to.)

J. Stirling. Notes on the Beni Limestones, 11.—W. Nelson. Geological Observations at Wauru Ponds, 19.—R. von Lendenfeld and J. Stirling. Exploration of Mount Bogong, 22.—T. W. E. David. Notes on some Points of Basalt Eruption in New South Wales, 24.

Milan. Società Italiana di Scienze Naturali. Atti. Vol. xxviii. Fasc. 1–4. 1885–86.

F. Molinari. Nuove osservazioni sui minerali del granito di Baveno, 58.—G. B. Villa. Rivista geologica dei terreni della Brianza, 79.—G. Mercalli. Il terremoto sentito in Lombardia nel 12 settembre 1884, 120.—L. Ricciardi. Ricerche chimiche sulle rocce vulcaniche dei dintorni di Viterbo, 127.—F. Bassani. Avanzi di pesci oolitici nel Veronese, 142.—F. Sacco. La Valle della Stura di Cuneo, 215, 269.—F. Molinari. Il porfido del Motterone, 264.

Mineralogical Society. Mineralogical Magazine and Journal. Vol. vii. Nos. 32 & 33. 1886.

T. G. Bonney. On a Glaucofane-eclogite from the Val d'Aoste, 1.—W. J. Lewis. On Idocrase and other Minerals recently found near Zermatt, 9.—H. A. Miers. Orthoclase from Kilima-njaro and Adularia from Switzerland, 10.—A. Taylor. On the Nomenclature of the Hydrocarbon Compounds, with a suggestion for a new classification, 13.—J. F. Kerr. The Metallic Ores of Chili, 18.—W. H. Bell. New Localities for the Mineral Agalmatolite, with notes on its composition, 24.—W. I. Macadam. On a New Locality for Agalmatolite, 29.—W. I. Macadam. On some New Localities for the Mineral Diatomite, with notes on the Chemical Composition of the Specimens exhibited, 30.—J. S. G. Wilson and W. I. Macadam. Diatomaceous Deposits in Skye, 35.—W. I. Macadam. On the Chemical Composition of the Mineral Bruiachite found by Mr. T. D. Wallace, of Inverness, at Loch Bhruithaich, 42.—C. O. Trechmann. Barytes from Addiewell, West Calder, in Midlothian, 49.—R. H. Solly. Francolite, a variety of Apatite from Levant Mine, St. Just, Cornwall, 57.—H. Robinson. Two Analyses of Crystals of Apatite, 59.—R. H. Solly. Anglesite from Portugal, 61.—E. Kinch. On Plattnerite, 63.—E. Kinch. On a new variety of Mineral from Cornwall, 65.—J. H. Hampton. Cassiterite of the Straits Settlements, 71.—W. I. Macadam. On the Occurrence of considerable Deposits of Limonite (Bog Iron Ore) in North-west Ross-shire, 72.—W. I. Macadam. Further Note on Agalmatolite in Gairloch Parish, Ross-shire, 74.—W. I. Macadam. On the Analysis of a Sample of Talc used in Paper-making, 73.—W. I. Macadam. Analyses of Samples of China Clay (Kaolinite), Cornwall, 76.—D. Honeyman. Note on the Identification of the Scotch and New Brunswick "Albertites,"

77.—F. H. Butler. Note on Schorlaceous Rocks from near St. Austell, 79.—J. W. Judd. On the Relations between the Solution-planes of Crystals and those of Secondary Twinning; and on the Mode of Development of Negative Crystals along the former, 81.—H. A. Miers. Index to Mineralogical Papers, &c., 1885, 93.

Montreal. Natural History Society. Canadian Record of Science. Vol. ii. Nos. 3–6. 1886–87.

Sir J. W. Dawson. Presidential Address before the British Association for the Advancement of Science, Sept. 1886, 201.—H. A. Newton. Relation of the Earth's Rocks to Meteorites, 228.—G. F. Matthew. Discovery of a Pteraspidian Fish in the Silurian Rocks of New Brunswick, 251.—G. F. Matthew. Abstract of a Paper on the Cambrian Faunas of Cape Breton and Newfoundland, 255.—G. M. Dawson. The Canadian Rocky Mountains, 185.—H. M. Ami. Occurrence of *Scolithus* in rocks of the Chazy Formation, 304.—G. F. Matthew. The Pteraspidian Fish of the Silurian Rocks, 323.—F. Bain. On a Permian Moraine in Prince Edward Island, 341.—G. F. Matthew. Illustrations of the Fauna of the St. John Group, 357.—G. M. Dawson. Note on the Occurrence of Jade in British Columbia, and its employment by the Natives, 364.

———. Royal Society of Canada. Proceedings and Transactions for the year 1885. Vol. iii. 1886.

Section IV.

Sir. J. W. Dawson. On the Mesozoic Floras of the Rocky Mountain Region of Canada, 1.—E. J. Chapman. On the Wallbridge Hematite Mine, as illustrating the Stock-formed Mode of Occurrence of certain Ore Deposits, 23.—D. Honeyman. Geology of Cornwallis or McNab's Island, Halifax Harbour, 27.—G. F. Matthew. Illustrations of the Fauna of the St. John Group (*continued*), No. III., 29.

Moscow. Société Impériale des Naturalistes. Bulletin. Tome lxi. 2^e partie (1885). Nos. 3 & 4. 1886.

H. Trautschold. Ueber das Genus *Edestus*, 94.

———. ———. ———. Tome lxii. 1^e partie (1886). Nos. 1 & 2. 1886.

A. Pavlow. Note sur l'histoire de la faune kimmérienne de la Russie, 227.

———. ———. ———. Tome lxii. 2^e partie (1886). Nos. 3 & 4. 1886.

M. Pavlow. Les ammonites du groupe *Olcostephanus versicolor*, 27.

———. ———. ———. Tome lxiii. 1^e partie (1887). Nos. 1 & 2. 1887.

D. Anutschin. Ueber die reste des Höhlenbären aus Transkaukasien, 216, 375.—M. Pavlow. Etudes sur l'histoire paléontologique des ongulés en Amérique et en Europe, 343.

———. ———. Nouveaux Mémoires. Tome xv. Livr. 4. 1886.

H. Trautschold. Le Néocomien de Sably en Crimée, 119.

Munich. Königlich-bayerische Akademie der Wissenschaften. Abhandlungen der mathematisch-physikalischen Classe. Band xv. Abth. 3. 1886.

Nancy. Académie de Stanislas. Mémoires, 1885. 136^e Année.
5^e Série. Tome iii. 1886.

———. Société des Sciences. Bulletin. Série 2. Tome viii. Fasc. 19.
1886.

Fliche. Note sur la flore de l'étage rhétien aux environs de Nancy,
150.

Nature. Vol. xxxiv. Nos. 869-887. 1886.

A. Blytt. On Variations of Climate in Course of Time, 220.—J. M. Alexander. The Craters of Mokuaweowes, on Mauna Loa, 232, 239.—The Volcanic Eruption in New Zealand, 301.—A. Geikie. The recent Volcanic Eruption in New Zealand, 320.—C. Reid. The Pliocene Deposits of North-western Europe, 341.—W. C. Williamson. Our Fossil Pseudo-Algæ, 369.—J. Hector. The recent Volcanic Eruption in New Zealand, 389.—Sir J. W. Dawson. Inaugural Address delivered to the British Association Meeting at Birmingham, 409.—T. G. Bonney. Opening Address to Section C, Geology, British Association, 442.—W. Topley. The recent American Earthquake, 470.—R. von Lendenfeld. A Glacial Period in Australia, 522.—J. S. Gardner. Sketch of the Early History and Subsequent Progress of Palæobotany, 598.—The recent Earthquakes and Volcanic Eruptions, 599.—Sir R. S. Ball. Note on the Astronomical Theory of the Great Ice Age, 607.

———. Vol. xxxv. Nos. 888-912. 1886-87.

E. Hull. The Geology of the Lebanon, 10.—J. Milne. Volcanoes of Japan, 19.—T. C. Mendenhall. Report on the Charleston Earthquake, 31.—W. Topley. The Erosion of the English Coasts, 37.—T. G. Bonney. Volcanic Dust from New Zealand, 56.—H. C. Lewis. Comparative Studies upon the Glaciation of North America, Great Britain, and Ireland, 89.—T. G. Bonney. Volcanic Eruption in Niua-fu, Friendly Islands, 127.—J. S. Hay and J. M. Metzger. Earthquake in Sierra Leone, 141.—Deposits of Volcanic Dust, 174.—J. Stirling. On some Further Evidences of Glaciation in the Australian Alps, 182.—J. W. Judd. The Relations between Geology and the Mineralogical Sciences, 392, 414.—Earthquake in Switzerland, 442.—J. W. Judd. The Relation of Tabasheer to Mineral Substances, 488.—W. E. Hidden. The Mazapil Meteoric Iron, 572.—T. H. Huxley. Preliminary Note on the Fossil Remains of a Chelonian Reptile, *Ceratochelys sthenurus*, from Lord Howe's Island, Australia, 615.

———. Vol. xxxvi. Nos. 914-920. 1887.

R. Abercromby. Upper Wind-Currents near the Equator, and the Diffusion of Krakatao Dust, 85.—A. B. Dick. On Zircons and other Minerals contained in Sand, 91.—J. A. Ewing. A recent Japanese Earthquake, 107.—The Fossil Fishes of Mount Lebanon, 132.—P. W. Bassett-Smith. Notes on the Geology of part of the Eastern Coast of China and the adjacent Islands, 163.

Neuchâtel. Société des Sciences Naturelles. Bulletin. Tome xv.
(1884-1886). 1886.

F. de Tribolet. Notes sur la Carte du phénomène erratique et des anciens glaciers du versant Nord des Alpes suisses et de la chaîne du Mont-Blanc, de M. A. Favre, 3.—F. de Tribolet. Sur la Carte des bassins erratiques de la Suisse d'Arnold Guyot, 9.—A. Hirsch. Note sur l'éruption de Krakatau, 47.—A. Jaccard. Note sur la source de la Reuse et le Bassin des Taillières, 60.—F. de Tribolet. Les tremblements de terre en Espagne, 83.

Newcastle-upon-Tyne. Natural History Society of Northumberland, Durham, and Newcastle-upon-Tyne, and Tyneside Naturalists' Field Club. Natural-History Transactions. Vol. viii. Part 3. 1886.

———. ———. ———. Vol. ix. Part 1. 1887.

———. North of England Institute of Mining and Mechanical Engineers. Transactions. Vol. xxxv. Parts 3 & 4. 1886.

J. D. Kendall. The Iron Ores of the English Secondary Rocks, 105.—
G. J. Binns. Coal-Mining in New Zealand, 175.

———. ———. ———. Transactions. Vol. xxxvi. Parts 1 & 2. 1887.

G. A. Lebour. Notes on the Coal-Measures of Catalonia, Spain, 33.

New Haven. American Journal of Science. Ser. 3. Vol. xxxii. Nos. 187-192. 1886.

C. G. Rockwood, jun. Notes on American Earthquakes, 7.—O. Meyer. Observations on the Tertiary and Grand Gulf of Mississippi, 20.—A. Hague and J. P. Iddings. Notes on the Volcanic Rocks of the Republic of Salvador, Central America, 26.—H. M. Seely. The Genus *Strophochetus*, distribution and species, 31.—N. S. Shaller. Preliminary Report on the Geology of Cobscook Bay District, Maine, 35.—J. D. Dana. On some General Terms applied to Metamorphism and to the Porphyritic Structure of Rocks, 69.—S. L. Penfield and D. N. Harper. On the Chemical Composition of Herderite and Beryl, with note on the Precipitation of Aluminum and Separation of Beryllum and Aluminum, 107.—W. Cross and L. G. Eakins. On Ptilolite, a new Mineral, 117.—J. S. Diller. Notes on the Peridotite of Elliot County, Kentucky, 121.—E. S. Dana. On the Crystallization of Gold, 132.—C. D. Walcott. Classification of the Cambrian System of North America, 138.—J. Le Conte. A Post-Tertiary Elevation of the Sierra Nevada shown by the River Beds, 167.—H. S. Williams. Devonian Lamellibranchiata and Species-making, 192.—G. P. Merrill. Composition of certain "Pliocene Sandstones" from Montana and Idaho, 199.—W. E. Hidden and A. des Cloizeaux. Contributions to Mineralogy, 204.—F. W. Clarke and J. S. Diller. Turquoise from New Mexico, 211.—E. S. Dana and S. L. Penfield. On two hitherto-undescribed Meteoric Stones, 226.—J. D. Dana. A dissected Volcanic Mountain; some of its revelations, 247.—R. D. Irving. Origin of the Ferruginous Schists and Iron Ores of the Lake Superior region, 255.—H. A. Wheeler. Further Notes on the Artificial Lead Silicates from Bonne Terre, Mo., 273.—J. G. Meem. Limonite Pseudomorphs after Pyrite, 274.—O. W. Huntington. On the Crystalline Structure of Iron Meteorites, 284.—W. E. Hidden. A new Meteoric Iron from Texas, 306.—S. L. Penfield and F. L. Sperry. On Pseudomorphs of Garnet from Lake Superior and Salida, Colorado, 307.—G. F. Kunz. Further Notes on the Meteoric Iron from Glorieta Mt., New Mexico, 311.—E. S. Dana. On the Brookite from Magnet Cove, Arkansas, 314.—W. M. Davis. The Structure of the Triassic Formation of the Connecticut Valley, 342.—F. W. Clarke. Researches on the Lithia Micas, 353.—J. C. Branner. Thickness of the Ice in North-eastern Pennsylvania during the Glacial Epoch, 362.—T. M. Chatard. Lucasite, a new variety of Vermiculite, 375.—W. G. Brown. Crystallographic Notes, 377.—S. L. Penfield and D. N. Harper. Chemical Composition of Ralstonite, 380.—E. S. Dana. Mineralogical Notes, 386.—E. S. Dana. On the Crystallization of Native Copper, 413.—W. N. Rice. On the Trap and Sandstone in the Gorge of

the Farmington River at Tariffville, Conn., 430.—H. C. Lewis. Comparative Studies upon the Glaciation of North America, Great Britain, and Ireland, 433.—I. P. Bishop. On certain Fossiliferous Limestones of Columbia Co., N. Y., and their relation to the Hudson River Shales and the Taconic System, 438.—S. L. Penfield. Crystallized Vanadinite from Arizona and New Mexico, 441.—S. W. Ford. Note on the Age of the Swedish Paradoxides Beds, 473.

New Haven. American Journal of Science. Ser. 3. Vol. xxxiii. Nos. 193-197. 1887.

C. A. White. Age of Coal found in the region traversed by the Rio Grande, 18.—J. S. Diller. The latest Volcanic Eruption in Northern California, and its peculiar Lava, 45.—G. F. Becker. The Texture of Massive Rocks, 50.—G. F. Kuntz. Fifth Mass of Meteoric Iron from Augusta Co., Va., 58.—J. S. Emerson, L. L. Van Slyke, F. S. Dodge. Kilauea after the Eruption of March 1886, 87.—J. D. Dana. Volcanic Action, 102.—P. W. Huntington. The Coahuila, 115.—S. L. Penfield. Phenacite from Colorado, with notes on the Locality of Topaz Butte by W. B. Smith, 130.—G. H. Williams. The Norites of the "Cortlandt Series" on the Hudson River, near Peekskill, N. Y., 135, 191.—A. N. Alling. On the Topaz from the Thomas Range, Utah, 146.—G. F. Becker. Natural Solutions of Cinnabar, Gold, and associated Sulphides, 199.—N. S. Shaler. Fluvial Swamps of New England, 210.—W. E. Hidden. On the Mazapel Meteoric Iron, which fell November 27, 1887, 221.—G. F. Kuntz. On two new Meteorites from Carroll County, Kentucky, and Catozze, Mexico, 228.—J. J. Stevenson. The Faults of South-west Virginia, 262.—J. D. Dana. On Taconic Rocks and Stratigraphy, with a Geological Map of the Taconic Regions, 270.—G. H. Kinahan. Irish Esker Drift, 276.—A. H. Chester. Mineralogical Notes from the Laboratory of Hamilton College, 284.—R. T. Hill. The Topography and Geology of the Cross Timbers and surrounding regions in Northern Texas, 291.—O. C. Marsh. American Jurassic Mammals, 327.—C. A. White. On the Inter-Relation of Contemporaneous Fossil Faunas and Floras, 364.—L. P. Gratacap. The Eozoonal Rock of Manhattan Island, 374.—G. H. Stone. Terminal Moraines in Maine, 378.—C. R. Van Hise. Note on the Enlargement of Hornblendes and Augites in Fragmental and Eruptive Rocks, 385.—J. D. Dana. On Taconic Rocks and Stratigraphy, with a Geological Map of the Taconic Region, 393.

———. Connecticut Academy of Arts and Sciences. Transactions. Vol. viii. Part 1. 1886.

New York. Academy of Sciences. Annals. Vol. iii. Nos. 9-12. 1885.

G. F. Kuntz. On remarkable Copper Minerals from Arizona, 275.—G. F. Kuntz. The Meteorite from Glorieta Mountain, Santa Fé, New Mexico, 329.—F. J. H. Merrill. On the Geology of Long Island, 341.—A. A. Julien. On the Variation of Decomposition in the Iron Pyrites; its Cause and its relation to Density, 365.

———. Transactions. Vol. v. (1885-86). Nos. 2-8. 1886.

J. S. Newberry. Description of some Gigantic Placoderm Fishes recently discovered in the Devonian of Ohio, 25.—B. B. Chamberlin. Minerals of Harlem and Vicinity, 74.—J. J. Friedrich. Notes on Local Mineralogy, 121.—R. P. Stevens. On the San Juan Mountains of Colorado, 121.—G. F. Kuntz. Rare Gems and interesting Minerals, 131.—J. S. Newberry. The Cretaceous Flora of North America, 133.—G. F.

Kuntz. Notes on some Minerals from the West, 213.—N. L. Britton. Geological Notes in Western Virginia, North Carolina, and Eastern Tennessee, 215.—G. F. Kuntz. Mineralogical Notes, 223.—G. F. Kuntz. A Meteorite from Catorce, Mexico, 227.—B. B. Chamberlin. Minerals of Staten Island, 228.—G. F. Kuntz. Description of a large Garnet, 265.—G. F. Kuntz. On Rock Crystal; its Cutting in Japan, Germany, and the United States, 267.

New York. American Museum of Natural History. Annual Report of the Trustees, for the year 1886–87. 1887.

———. ———. Bulletin. Vol. i. Nos. 7 & 8. 1886.

R. P. Whitfield. Notice of Geological Investigations along the Eastern Shore of Lake Champlain, conducted by H. M. Seely and Ezra Brainerd, of Middlebury College, with Descriptions of the new Fossils discovered, 295.—R. P. Whitfield. Notice of a new Fossil Body, probably a Sponge related to *Dictyophyton*, 346.

Northampton. Northamptonshire Natural-History Society and Field Club. Journal. Vol. iii. No. 24. 1885.

———. ———. ———. Vol. iv. Nos. 25 & 26. 1886.

B. Thompson. The Upper Lias of Northamptonshire, 16.—B. Thompson. Additional Notes on the Fish and Insect Beds of Northamptonshire, 27.—H. J. Eunson. Notes on the Deep Boring at Orton, near Kettering, Northamptonshire, 57.

———. ———. ———. Vol. iv. Nos. 28 & 29. 1886 & 1887.

W. Tuckwell. The Erratics of Leicestershire and Warwickshire, 145.—B. Thompson. The Middle Lias of Northamptonshire, 167.—H. J. Eunson. List of Works on the Geology, Mineralogy, and Palæontology of Northamptonshire, 178.—G. R. Vine. Jurassic Polyzoa in the Neighbourhood of Northampton, 202.—B. Thompson. The Upper Lias of Northamptonshire, 215.—W. D. Crick. Note on some Foraminifera from the Oxford Clay at Keyston, near Thrapston, 232.

Nottingham Naturalists' Society. Transactions and 33rd Annual Report, 1885. 1886. *Presented by W. Whitaker, Esq., F.G.S.*
E. R. Hodges. The Krakatoa Catastrophe, 39.

———. Transactions and 34th Annual Report, 1886. 1887.

A. T. Metcalfe. Rain and Rivers as Geological Agents, 35.—J. Shipman. Some traces of the Ancient Beach of the Lower Keuper at Donnington, 61.

Palæontographical Society. Monographs. Vol. xl. for 1886. 1887. (Two copies.)

W. C. Williamson. A Monograph on the Morphology and Histology of *Stigmaria ficoides*, part 1.—G. J. Hinde. A Monograph of the British Fossil Sponges, part 1.—W. H. Hudleston. A Monograph of the British Jurassic Gasteropoda, part 1, No. 1.—S. S. Buckman. A Monograph on the Inferior Oolite Ammonites, part 1.—W. Boyd Dawkins. The British Pleistocene Mammalia, part 6.

Paris. Académie des Sciences. Comptes Rendus. Tome cii. Nos. 25 & 26. 1886.

E. Jacquot. Sur la constitution géologique des Pyrénées, 1506.—C. Vélain. Sur la présence d'une rangée de blocs erratiques échoués sur la

côte de Normandie, 1589.—H. Silvestri. Sur l'éruption de l'Etna de mai et juin 1886, 1589.

Paris. Académie des Sciences. Comptes Rendus. Tables. 1886.

———. ———. ———. Tome ciii. Nos. 1-26. 1886.

G. de Saporta. Sur l'horizon réel qui doit être assigné à la flore fossile d'Aix en Provence, 27, 191.—A. F. Noguès. Sur le système triasique des Pyrénées Orientales, à propos d'une communication de M. Jacquot, 91.—E. Rivière. Faune des Invertébrés des grottes de Menton, en Italie, 94.—H. Faye. Sur les rapports de la Géodésie avec la Géologie, 99, 295.—R. Bréon. Sur l'association cristallographique des feldspaths tricliniques, 170.—Viguier. Sur les roches des Corbières appelées ophites, 172.—C. Barrois et A. Offret. Sur les schistes micacées primitifs et cambriens du sud de l'Andalousie, 174.—C. Barrois et A. Offret. Sur les schistes et gneiss amphiboliques, et sur les calcaires du sud de l'Andalousie, 221.—E. Hébert. Observations sur les groupes sédimentaires les plus anciens du nord-ouest de la France, 230.—L. Crié. Recherches sur la végétation miocène de la Bretagne, 290.—C. Lory. Sur la présence de cristaux microscopiques de minéraux du group des feldspaths, dans certains calcaires jurassiques des Alpes, 309.—C. Barrois et A. Offret. Sur la disposition des brèches calcaires des Alpujarras, et leur ressemblance avec les brèches houillères du nord de la France, 400.—E. Willm. Sur la composition des eaux de Bagnères-de-Luchon (Haute-Garonne), 416.—Nadaillac. Sur la découverte, faite en Belgique, d'une sépulture de l'âge du Mammouth et du Rhinocéros, 490.—A. Caraven-Cachin et Grand. Nouvelles recherches sur la configuration et l'étendue du bassin houiller de Carmaux, 527.—L. Crié. Sur les affinités des flores oolithiques de la France occidentale et de l'Angleterre, 528.—L. Vidal. Sur le tremblement de terre du 27 août en Grèce, 563.—F. Schrader. Carte représentant les terrains granitiques et crétacés des Pyrénées espagnoles et leur disposition en chaînons obliques et successifs, 565.—F. Fontannes. Constitution géologique du sol de la Croix-Rousse, Lyon, 613.—F. Gonnard. De quelques roches grenatifères du Puy-de-Dôme, 654.—S. Meunier. Sur le gîte phosphaté de Beauval, Somme, 657.—L. Crié. Contribution à l'étude des flores tertiaires de la France occidentale et de la Dalmatie, 699.—Gurlt. Météorite trouvée dans un lignite tertiaire, 702.—A. Daubrée. Météorite tombée le 27 Janvier 1886 dans l'Inde, à Mammianthul, province de Madras, 726.—C. E. Bertrand et B. Renault. Remarques sur le *Poroxyton stephanense*, 765.—A. de Lapparent. Sur les rapports de la Géodésie avec la Géologie, 772.—C. E. Bertrand et B. Renault. Nouvelles remarques sur la tige des Poroxytons, Gymnospermes fossiles de l'époque houillère, 820.—A. Lacroix. Examen pétrographique d'une diabase carbonifère des environs de Dumbarton (Écosse), 824.—E. Jourdy. Les dislocations du globe pendant les périodes récentes, leurs réseaux de fractures et la conformation des continents, 826.—H. Hermite. Sur l'unité des forces en Géologie, 829.—Stanislas Meunier. Substance singulière recueillie à la suite d'un météore rapporté à la foudre, 837.—H. Faye. Réponse à une Note de M. de Lapparent sur les rapports de la Géodésie et de la Géologie, 841.—Marcel de Puydt et Max. Lehest. Sur les habitants de la grotte de la Bêche-aux-Roches, 893.—L. Crié. Sur les affinités des flores éocènes de la France occidentale et de la province de Saxe, 894.—E. Rivière. Faune des oiseaux trouvés dans les grottes de Menton, Italie, 944.—G. Cotteau. Sur les Echinides jurassiques de la Lorraine, 947.—A. Gaudry. La grotte de Montgaudier, 970.—J. A. Le Bel. Sur les pétroles de Russie, 1017.—S. Meunier. Calcaire grossier marin des environs de Provins (Seine-et-Marne), 1031.—C. Depéret. Sur

le système dévonien de la chaîne orientale des Pyrénées, 1033.—F. Gonnard. Sur les pléromorphoses de quartz de Saint Clément, 1036.—A. Lacroix. Description d'une variété de carphosidérite, 1037.—A. de Lapparent. Sur les conditions de forme et de densité de l'écorce terrestre, 1040.—L. Crié. Contribution à l'étude des fruits fossiles de la flore éocène de la France occidentale, 1143.—E. Bureau. Sur la formation de Bilobites à l'époque actuelle, 1164.—S. Meunier. Examen d'eaux minérales de Java, 1205.—De Folin. Sur une nouvelle situation des roches nummulitiques de Biarritz, 1207.—C. Depéret. Sur l'importance et la durée de la période pliocène, d'après l'étude du bassin du Roussillon ; nouveaux documents pour le faune de Mammifères pliocènes de ce bassin, 1208.—É. Rivière. Des Reptiles et des Poissons trouvés dans la grotte de Menton, Italie, 1211.—F. Gonnard. Sur deux roches à béryl et à apatite du Velay et du Lyonnais, 1283.

Paris. Académie des Sciences. Comptes Rendus. Tome civ.
Nos. 1-24. 1887.

A. F. Noguès. Observations relatives à une Note de M. Viguié, sur les roches des Corbières appelées ophites, et à une Communication de M. Depéret, sur le système dévonien de la chaîne orientale des Pyrénées, 93.—S. Meunier. Examen microscopique des cendres du Krakatau, 95.—A. Lacroix. Examen critique de quelques minéraux, 97.—De Lesseps. Sur divers phénomènes offerts par les puits artésiens récemment forés en Algérie, 135.—L. Collot. Age de la bauxite dans le sud-est de la France, 127.—Venukoff. Considérations sur la Carte géologique du lac Baïkal et de ses environs, 137.—V. Lemoine. Sur le genre *Plesiadapis*, mammifère fossile de l'éocène inférieur des environs de Reims, 190.—S. Meunier. La Giovanite, nouvelle roche cosmique, 193.—A. Lacroix. Description d'une *Thomsonite* lamellaire de Bishopton, Renfrewshire, Ecosse, 234.—A. Lacroix. Sur une épidote blanche du canal du Beagle, Terre de Feu, 235.—A. Issel. Sur l'existence de vallées submergées dans le golfe de Gènes, 250.—F. Gonnard. Sur certains phénomènes de corrosion linéaire de la calcite de Couzon, Rhône, 316.—A. Issel. Sur l'époque du creusement des vallées submergées du golfe de Gènes, 318.—C. Depéret. Sur la faune de Vertébrés miocènes de la Grive-Saint-Alban, Isère, 379.—J. Thoulet. Expériences synthétiques sur l'abrasion des roches, 381.—L. Roule. Sur les gisements et l'âge de la bauxite dans le sud-est de la France, 383.—Favarcq et Grand'Eury. Sur un grès d'origine organique découvert dans les couches de houille du bassin de la Loire, 393.—V. Lemoine. Sur l'ensemble des recherches paléontologiques faites dans les terrains tertiaires inférieurs des environs de Reims, 403.—E. Bureau. Sur le mode de formation des Bilobites striés, 405.—P. Hautefeuille et L. Péan de Saint-Gilles. Sur la reproduction des micas, 508.—D. Ehlert. Sur les oscillations qui se sont produites pendant la période primaire dans le bassin de Laval, 528.—J. Bergeron. Sur la constitution géologique de la Montagne-Noire, 530.—E. Stephan. Le tremblement de terre du 23 février, à l'observatoire de Marseille, 556.—A. Gorgeu. Sur le ferrite de zinc. Production artificielle de la franklinite, 580.—G. Rolland. Sur la géologie de la région du lac Kelbia et du littoral de la Tunisie centrale, 597.—Reilly. Sur les gisements de l'étain, au point de vue géologique, 600.—K. de Kroustchoff. Sur de nouveaux procédés de reproduction artificielle de la silice cristallisée et de l'orthose, 602.—Fines. Sur le tremblement de terre du 23 février, enregistré à l'observatoire de Perpignan, 606.—F. A. Forel. Sur les effets du tremblement de terre du 23 février 1887 dans la Suisse orientale, 608.—S. Meunier. Tremblement de terre du 23 février, à Nice, 611.—A. Tissot. Le tremblement de terre du 23 février, à Voreppe, Isère, 611.—J. Réveille. Le tremblement de terre

du 23 février, à Saint-Tropez, 612.—F. Denza. Tremblement de terre du 23 février en Italie, 659.—François. Propagation du tremblement de terre de la Ligurie, 660.—A. Issel. Sur le tremblement de terre de la Ligurie, 662.—M. E. de Rossi. Sur la tempête sismique italienne-française du 23 février, 1887, 664.—Alluard. Secousses de tremblement de terre ressenties à Clermont-Ferrand, le 23 février, 666.—Perrotin. Le tremblement de terre du 23 février à Nice, 666.—A. Lacroix. Sur les variations de composition des porphyrites carbonifères du Renfrewshire, Ecosse, 717.—F. Gonnard. Sur les associations minérales du basalte de Prudelles, près de Clermont-Ferrand, 719.—E. Fremy. Production artificielle du rubis, 737.—A. Gaudry. Le petit *Ursus spelæus* de Gargas, 740.—F. Fouqué. Renseignements divers recueillis sur le tremblement de terre du 23 février 1887, 744.—F. Denza. Sur le tremblement de terre du 23 février, 757.—S. Meunier. Premiers résultats d'une exploration de la zone ébraalée par le tremblement de terre du 23 février, 759.—II. de Parville. Sur une corrélation entre les tremblements de terre et les déclinaisons de la Lune, 761.—J. L. Soret. Le tremblement de terre du 23 février, en Suisse, 764.—Galli. Le tremblement de terre du 23 février, à l'observatoire de Velletri, 765.—C. Naudin. Quelques observations et réflexions au sujet du tremblement de terre du 23 février, à Antibes, 822.—B. Nièpce. Documents sur les tremblements de terre de Nice, 830.—E. Tamburini. Le tremblement de terre du 23 février à la Spezia, 831.—A. de Vaux. Le tremblement de terre du 23 février, en Ligurie, 832.—F. A. Forel. Tremblement de terre et grisou, 833.—A. Blavier. Sur la cause possible des tremblements de terre de 1755, 1884 et 1887, 835.—A. Lacroix. Étude pétrographique d'un gabbro à olivine de la Loire-Inférieure, 870.—S. Meunier. Examen minéralogique du fer météorique de Fort-Duncan, Texas, 872.—Extraits de divers Rapports du Service local du Génie sur les effets du tremblement de terre du 23 février 1887, 884.—F. Denza. Le tremblement de terre du 23 février 1887, observé à Moncalieri, 887.—H. Resal. Sur un fait qui s'est produit près de Nice lors de la dernière secousse de tremblement de terre, 950.—G. de Saporta. Sur quelques types de Fougères tertiaires nouvellement observés, 954.—A. Lacroix. Note sur une roche à wernérite granulitique des environs de Saint-Nazaire, 1011.—S. Meunier. Examen de quelques galets du nagelfluhe du Rigi, 1013.—Oppermann. Sur les tremblements de terre, 1041.—L. Soret. Sur le tremblement de terre du 23 février 1887, 1088.—S. Meunier. Reproduction artificiels du spinelle rose ou rubis calais, 1111.—A. Offret. Sur le tremblement de terre du 23 février 1887, 1150.—A. Gorgeu. Production artificielle de la magnétite, 1174.—L. Bourgeois. Nouveau procédé de reproduction de la crocoise, 1302.—F. Gonnard. Sur les associations minérales de la pépérite du puy de la Poix, 1304.—L. Lartet. Sur le terrain carbonifère des Pyrénées centrales, 1314.—L. Lecornu. Sur le terrain silurien du Calvados, 1317.—E. Jacquot. Sur la constitution géologique des Pyrénées; le système cambrien, 1318.—P. Thomas. Sur la découverte de nouveaux gisements de phosphate de chaux en Tunisie, 1321.—E. Rivière. De quelques bois fossiles trouvés dans les terrains quaternaires du bassin parisien, 1382.—H. Le Chatelier. Sur la constitution des argiles, 1517.—G. Cotteau. Sur les genres éocènes de la famille des Brissidés (Echinides irréguliers), 1532.—C. Rolland. Sur le régime des eaux artésiennes de l'Oued Rir' (Sahara algérien), 1534.—Munier-Chalmas. Observations sur les actions métamorphiques du granite et des filons de quartz aux environs de Morlaix, 1738.

Paris. Académie des Sciences. Comptes Rendus. Index to
Tome ci. 1885.

Paris. Annales des Mines. Série 8. Tome ix. 2^e et 3^e livraisons de 1886. 1886.

B. de Chancourtois, C. Lallemant, et G. Chesneau. De l'étude des mouvements de l'écorce terrestre poursuivie particulièrement au point de vue de leurs rapports avec les dégagements de produits gazeux, 207.—J. de Morgan. Note sur la géologie et sur l'industrie minière du royaume de Pérag et des pays voisins (prèsqu'île de Malacca), 368.—E. Jacquot. Note sur la carte géologique détaillée de la France, 577.

———. ———. ———. Tome x. 4^e et 5^e livraisons de 1886. 1886.

L. Bochet. Étude sur la bassin houiller de Waldenburg (Basse-Silésie), 221.—M. Pellé. Étude sur les salines de Roumanie, 280.—De Grossouvre. Étude sur les gisements de minerai de fer du centre de la France, 311.

———. Annales des Sciences Géologiques. Tome xv. 1884.
Purchased.

Croisiers de Lacvivier. Études géologiques sur la département de l'Ariège et en particulier sur le terrain crétacé, No. 1.

———. ———. Tome xvi. 1885. *Purchased.*

G. Vasseur. Sur le terrain tertiaire de Saint-Palais, près Royan, Charente-Inférieure, No. 1.—G. Cotteau. Echinides du terrain éocène de Saint-Palais, No. 2.—P. Fontannes. Note sur quelques gisements nouveaux des terrains miocènes du Portugal et description d'un Portunien du genre *Achelous*, No. 3.—H. Filhol. De la restauration du squelette d'un Dinocerata, No. 4.—L. Dieulafait. Étude sur les roches ophitiques des Pyrénées, No. 5.—J. Dollo. Les découvertes de Bernissart, No. 6.—P. Gourret. Constitution géologique du Larzac et des Causses méridionaux du Languedoc, No. 7.

———. ———. Tome xvii. 1885. *Purchased.*

C. Depéret. Description géologique du bassin tertiaire du Roussillon et description des vertébrés fossiles du terrain pliocène du Roussillon, No. 1.—H. Filhol. Observations sur le mémoire de M. Cope intitulé : Relations des horizons renfermant des débris d'animaux vertébrés fossiles en Europe et en Amérique, No. 2.—B. Renault. Recherches sur les végétaux fossiles du genre *Astromyelon*, No. 3.—O. C. Marsh. Monographie des Dinocerata, mammifères gigantesques appartenant à un ordre disparu, No. 4.

———. ———. Tome xviii. 1885. *Purchased.*

E. Fallot. Étude géologique sur les étages moyens et supérieurs du terrain crétacé dans le sud-est de la France, No. 1.—L. Roule. Recherches sur le terrain fluvio-lacustre inférieur de Provence, No. 2.

———. Annales des Sciences Naturelles. Zoologie et Paléontologie. Série 6. Tome xx. Nos. 3-6. 1886. *Purchased.*

———. ———. ———. Serie 7. Tome i. Nos. 1-6. 1886 & 1887. *Purchased.*

———. Annales Hydrographiques. Série 2. Sém. 1 et 2 (1886). 1887. *Presented by the Dépôt de la Marine.*

———. ———. ———. Sém. 1 (1887). 1887. *Presented by the Dépôt de la Marine.*

Paris. Association Française pour l'Avancement des Sciences.
Compte Rendu de la Session 13, Blois, 1884. Parties 1 & 2
1885. *Purchased.*

Partie 1.

E. Cosson. Sur le projet de création en Algérie et en Tunisie d'une Mer dite intérieure, 57.—Rouire. La Mer intérieure Africaine, 75.—G. de Saporta. Note sur les Echinides des couches coralliennes inférieures d'Auxey. Côte-d'Or, 179.—E. Fuchs. Les richesses minérales du Tonkin, 181.—Bleicher. Terrain tertiaire d'Alsace, 183.—G. de Saporta. Sur deux espèces jurassiques du genre *Orthopsis*, Cotteau, 183.

Partie 2.

L. Quénauld. Mouvements lents du Sol et de la Mer, 215.—F. Lefort. Recherches sur l'âge relatif des différents systèmes de failles du Morvan, 226.—G. Cotteau. Sur les échinides des calcaires de Stramberg, 238.—V. Gauthier. Recherches sur le genre *Micraster* en Algérie, 243.—P. de Loriol. Sur le genre *Millericrinus*, 247.—G. de Saporta. Sur un nouveau gisement de plantes fossiles coralliennes, 253.—Douvillé et Le Mesle. Carte géologique des environs de Blois, 255.—V. Gauthier. Sur quelques échinides monstrueux, appartenant au genre *Hemiaster*, 258.—C. Barrois. Eponges hexactinellides du terrain dévonien du Nord de la France, 261.—C. Barrois. Couches à Nercites du Bourg-d'Oueil, Haute-Garonne, 262.—C. Barrois. Roches métamorphiques du Morbihan, 263.—Bleicher. Le lias de Lorraine au point de vue paléontologique, 265.—G. Rolland. Terrains de transport et terrains lacustres du Bassin du Chott Melhir, 267.

———. ———. Compte Rendu de la Session 14, Grenoble, 1885.
Parties 1 & 2. 1886. *Purchased.*

Partie 1.

G. Cotteau. Le Paléontologie en 1885, 44.—A. Pomel. Sur le station préhistorique de Ternifine, près Mascara, 128.—C. Malaise. État actuel des connaissances relatives au cambrien et silurien de la Belgique, 129.—L. Collot. Constitution du crétacé dans les Bouches-du-Rhône, 129.—J. M. Beroud. Sur la grotte des Balmes, près Villereversure, Ain, 132.—E. Fuchs. Sur les graviers aurifères de la Sierra Nevada en Californie, 133.

Partie 2.

L. Collot. Diversité correlative des sédiments et de la faune du miocène marin des Bouches-du-Rhône, 339.—Peron. Note sur les étages de la craie aux environs de Troves, 346.—V. Gauthier. Description de trois échinides nouveaux recueillis dans la craie de l'Aube et de l'Yonne, 356.—G. Cotteau. Considérations générales sur les échinides du terrain jurassique de la France, 362.—P. de Loriol. Coup d'œil d'ensemble sur les crinoïdes recueillis dans les couches jurassiques de la France, 364.—F. Lefort. Recherches sur l'âge relatif des différents systèmes de failles du Nivernais, 372.—L. Quénauld. Sur les oscillations lentes du sol et de la mer, 392.—E. Rivière. Le gisement quaternaire du Perreux, Seine, 401.—E. Rivière. La faune des invertébrés des grottes de Menton, 407.—E. Fuchs. Note sur les gisements de cuivre du Boles, 410.—D'Ault-Dumesnil. Nouvelles fouilles faites à Thenay en Septembre 1884, 463.—F. Daleau. Note sur les silex de Thenay, 467.—J. M. Beroud. La grotte des Balmes, près de Villereversure, en Revermont, Ain, 471.—Sirodot. L'âge du gisement du Mont-Dol, Ille-et-Vilaine, 478.—A. Arcelin. Sur les silex soi-disant taillés de l'époque tertiaire, 503.—A. Pomel. Station préhistorique de Ternifine, Mascara, 504.—E. Rivière. Le Trou au Loup, 553.

Paris. Journal de Conchyliologie. Série 3. Tome xxvi. Nos. 1-4. 1886. *Purchased.*

M. Cossman. Description d'espèces du terrain tertiaire des environs de Paris, 86, 224.—C. Meyer-Eyman. Description de coquilles fossiles des terrains tertiaires supérieurs, 235, 302.

———. ———. ———. Tome xxvii. Nos. 1 & 2. 1887. *Purchased.*

———. Muséum d'Histoire Naturelle. Nouvelles Archives. Sér. 2. Tome viii. Fasc. 1 & 2. 1885-86.

———. ———. ———. ———. Tome ix. Fasc. 1. 1886.

———. Revue Scientifique. Tome xxxvii. No. 26. 1886.

A. de Lapparent. L'attraction des glaces sur les masses d'eau voisines, 801.

———. ———. Tome xxxviii. Nos. 1-24 & 26. 1886.

De Montessus. La constitution interne du globe et les volcans, 369.—G. Cotteau. Association Française pour l'Avancement des Sciences. Session de Nancy (1886), Section de Géologie, 434.—Sir W. Dawson, La géologie de l'Atlantique, 449, 488.—H. Labonne. Les tourbières de l'Islande, 809.

———. ———. Tome xxxix. Nos. 1-25. 1887.

A. de Lapparent. L'excursion de la Société Géologique en Bretagne, 38.—E. Jourdy. Les dislocations du globe pendant les périodes récentes, leurs réseaux de fractures et la conformation des continents, 129, 335.—A. de Lapparent. Les dislocations du globe, 332.—G. Daremberg. Le tremblement de terre du 23 février à Menton, 338.—C. Vélain. Les tremblements de terre, leurs effets et leurs causes, 354, 395.—H. d'Estrey. Les mines d'or de Sumatra, 433.

———. Société Française de Minéralogie. Bulletin. Tome ix. Nos. 4-8. 1886. *Purchased.*

C. Baret. Minéraux des environs de Saint-Nazaire (Loire-Inférieure), 129.—A. Lacroix. Sur l'albite des pegmatites de Norvège, 131.—A. Des Cloizeaux. Note sur quelques formes nouvelles observées sur des cristaux de topaze de Durango, Mexique, 135.—A. Des Cloizeaux. Note sur la forme rhombique de la Descloizite, 138, 190.—A. Des Cloizeaux. Note sur la véritable valeur de l'indice moyen de la Herdérîte de Stoneham, 141.—K. de Kroustchoff. Note sur un nouveau minéral accessoire de la roche de Beucha (près de Leipzig), 143.—K. de Kroustchoff. Supplément à la note sur la Péridotite de "Goose Bay," 147.—A. Lacroix. Compte rendu de publications étrangères, 148, 186.—A. Damour. Note sur un béryl provenant de Madagascar, 153.—A. Des Cloizeaux. Note sur la phénacite de Colorado et de Framont, 171.—A. Des Cloizeaux. Note sur la détermination des paramètres du gypse et sur les incidences des formes observées dans ce minéral, 177.—A. Des Cloizeaux. Sur un minéral qui paraît offrir une forme dimorphe du rutile, 184.—E. Jannettaz. Note sur un chrysocolle de la Californie, 211.—L. Michel. Sur la décoloration partielle du Zircon (Hyacinthe) par la lumière, 215.—H. Dutremblay du May. Décoloration momentanée observée sur des agates soumises à l'influence des rayons solaires, 216.—L. J. Igelstrøm. Pyrrhoarsénite, nouveau minéral de Sjøegrufvan, 218.—G. Césàro. Note sur un assemblage de cristaux de cassitérite, 220.—G. Césàro. Extension de l'observation de M. Mallard sur la macle de Carlsbad, 222.—G. Césàro. Note sur une nouvelle face de la calamine, 242.—F. Gonnard. Sur les minerais auri-

fères des environs de Pontgibaud, 243.—L. Bourgeois. Sur des titanates de baryte et de strontiane cristallisés, 244.—K. de Kroustchoff. Notes pour servir à l'étude lithologique de la Volhynie, 250.—K. de Kroustchoff. Notice sur une hypérite de Seeland, 258.—G. Wyrouboff. Sur la forme cristalline du chlorure de baryum, 262.—G. Wyrouboff. Quelques mots à propos d'un mémoire de M. Schmidt sur la scolézite, 266.—G. Césaro. Note sur une propriété géométrique du rhomboèdre de clivage de la calcite, 281.—Fouqué. Sur un minéral artificiel provenant d'une scorie de forge, 287.—Fouqué. Sur un gisement de gneiss à cordiérite, 293.—N. Chatrian. Sur le gisement de diamants de Salobro, Brésil, 302.—A. Lacroix. Compte rendu des publications étrangères, 305.—E. Jannettaz. Note sur les rubis artificiels, 321.

Paris. Société Française de Minéralogie. Bulletin. Tome x.
Nos. 1-3. 1887. *Purchased.*

M. Lévy et Lacroix. Sur le granite à amphibole de Vaugneray, 27.—K. de Kroustchoff. Nouvelles synthèses du quartz et de la tridymite, 31.—A. Gorgeu. Sur la production artificielle de la Zincite et de la Willemite, 35.—H. Goguel. Comptes rendus des publications françaises, 39.—A. Des Cloizeaux. Liste des travaux de M. Websky, 43.—E. Jannettaz. Note sur l'uranite de Madagascar, 47.—Fouqué. Sur les nodules de la granulite de Ghistorrai, 57.—A. Michel-Lévy. Note sur un basalte riche en zéolithes des environs de Périer (Puy-de-Dôme), 69.—C. Baret. Sur la présence du béryl et de l'erubescite dans les carrières de Miséri, près Nantes, 131.—L. Michel. Note sur la reproduction artificielle de la pyromorphite, de la mimérite et de la campylite, 133.—A. Lacroix. Etudes critiques de Minéralogie, 142.—A. Lacroix. Note sur la composition pétrographique des roches de Blekka et Dalarne (Norwège), 152.

———. Société Géologique de France. Bulletin. Série 3. Tome xiii.
No. 8 (1885). 1886.

Compte rendus de la réunion extraordinaire dans la Jura méridional, du 23 Août au 1 Septembre 1885, 651. [With communications by MM. Bertrand, Parandier, Albert Girardot, Abel Girardot, Bourgeat, Hollande, Renevier, Guirand, De Grossouvre, Collot, G. Boyer, G. Maillard, Tardy, Pillet, De Sarrau, De Lapparent, and P. Choffat.]

———. ———. ———. ———. Tome xiv. Nos. 5-7 (1886). 1886.

De la Moussaye. Les îles flottantes de Clairmarais, 309.—Cornuel. Liste des fossiles du Crétacé inférieur de la Haute Marne, 312.—M. Cossmann et H. Arnaud. Un *Crucibulum* campanien, 323.—R. Zeiller. Note sur des empreintes houillères des Pyrénées-Orientales, 328.—Chaper. Sur une pegmatite diamantifère de l'Indoustan, 331.—J. De Cossigny. Note sur le Jurassique moyen et sa division en étages, 345.—B. Rames. Sur l'âge des argiles du Cantal et sur les débris fossiles qu'elles ont fournis, 357.—F. Sacco. Sur quelques restes fossiles de poissons du Pliocène du Piémont, 360.—A. de Lapparent. Le niveau de la mer, 368.—H. Douvillé. Essai sur la morphologie des Rudistes, 389.—S. Calderon. Note sur le Wealdien du Nord de l'Espagne, 405.—G. De Saporta. Nouveaux documents relatifs à des fossiles végétaux et à des traces d'invertébrés associés dans les anciens terrains, 407.—A. Gaudry. Sur un nouveau genre de reptile du Permien d'Autun, 430.—M. Cossman. Sur les grandes ovules de l'Éocène, 433.—L'Abbé Bourgeat. Observations faites aux environs d'Arinthod et de St. Julien, Jura, 437.—A. Gaudry. Sur des restaurations de reptiles, 444.—E. Jourdy. Note complémentaire sur la Géologie de l'est du Tonkin, 445.—R. Zeiller. Note sur les empreintes végétales recueillies par M. Jourdy au Tonkin, 454.—H. Douvillé. Étude sur les grès de la forêt de Fontainebleau, 471.—L. Flot. Descrip-

tion de *Halitherium fossile*, Gervais, 483.—A. Toucas. Note sur les terrains crétacés de la Valdaren aux environs du Beausset, 519.—A. de Lapparent. Note sur l'attraction exercée par les glaces sur les masses d'eau voisines, 524.—D. Ehlert. Failles et filons des environs de Montsurs, 526.—Mieg. Note complémentaire sur les couches à *Posidonomya Bronni*, de Minversheim (Basse-Alsace), 550.—L'Abbé Bourgeat. Première contribution à l'étude de la faune de l'Oolithe virgulienne du Jura méridional, 560.—S. Meunier. Sur quelques empreintes problématiques des couches boloniennes du Pas-de-Calais, 564.—C. Vélain. Note sur l'existence d'une rangée de blocs erratiques sur la côte normande, 569.—R. Zeiller. Note sur les empreintes végétales recueillies par M. Sarran dans les couches de combustible du Tonkin, 575.—Viguiier. Note sur la position du Poudingue de Palassou, dans l'Aude, 582.—De Rouville. Note sur le Poudingue de Palassou, 580.—E. Hébert. Remarques sur la faune des couches crétacées de Villagrains, 586.—P. W. Stuart-Menteth. Note préliminaire sur les gisements métallifères des Pyrénées occidentales, 587.—A. Pomel. Note sur deux échinides du terrain éocène, 608.—De Lacvivier. Note sur le terrain primaire du département de l'Ariège, 613.

Paris. Société Géologique de France. Bulletin. Série 3. Tome xv. (1887). Nos. 1-3. 1887.

L. de Launay. Note sur deux gisements de cordiérite, sillimanite et grenat dans la région de Commeny, 12.—Moutet. Note sur l'existence d'une formation wealdienne dans le département du Var, au quartier du Revest, près Toulon, 13.—H. Armand. Position stratigraphique des argiles bariolées de Tercis. Landes, 15.—Stanislas Meunier. Examen d'une substance résineuse recueillie à Luchon le 28 juillet 1885 à la suite d'un coup de foudre, 23.—F. Sacco. Le Fossanien, nouvel étage du Pliocène d'Italie, 27.—Salvador Calderon. Résumé de quelques études de physique géologique, 36.—C. Lory. Sur les variations du Trias dans les Alpes de la Savoie, et spécialement dans le massif de la Vanoise, 40.—F. Fontannes. Sur la faune des étages Sarmatique et Levantin en Roumanie, 49.—F. Delafond. Note sur les Tufs de Meximieux, 62.—F. Delafond. Note sur les alluvions anciennes de la Bresse et des Dombes, 65.—A. Tardy. Nouvelles observations sur la Bresse, 82.—L. Flot. Note sur le *Prohalicore Dubaleni*, 134.—P. Thomas. Notes additionnelles sur les vertébrés fossiles de la province de Constantine, 139.—A. Toucas. Observations sur la craie supérieure de Dieulefit, 149.—A. Toucas. Au sujet d'une note de M. de Lacvivier sur l'étude comparative des terrains crétacés de l'Ariège et de l'Aude, 153.—P. Choffat. Note préliminaire sur des fossiles recueillis par M. L. Maheira dans la province d'Angola, 155.—F. Rutot et E. Van den Broeck. Documents nouveaux sur la base du terrain tertiaire en Belgique, et sur l'âge du Tufeau de Ciplu, 157.—Bourgeat. Considérations sommaires sur la position des rognons siliceux du Jurassique supérieur dans le Jura méridional et sur les conséquences qui en découlent, 162.—G. Dollfus. Quelques nouveaux gisements de terrain tertiaire dans le Jura près de Pontarlier, 179.—R. Nicklès. Sur la présence de *Amm. polyschides* et *Amm. Sauzei* dans l'Oolithe inférieure des environs de Nancy, 194.—Pouech. Réponse aux observations de M. Viguiier et de M. de Rouville à propos des poudingues de Palassou, 199.—A. de Lapparent. Conférence sur le sens des mouvements de l'écorce terrestre, 215.

Penzance. Royal Geological Society of Cornwall. Transactions. Vol. xi. Part 1. 1887.

W. W. Smyth. The Anniversary Address of the President, 11.—R. W. Bell. The Pliocene Beds of St. Erth, 45.—R. N. Worth. On an unmapped exposure of Serpentinous Rock in Whitsand Bay, 51.

Philadelphia. Academy of Natural Sciences. Proceedings, 1886.

Parts 1-3. 1886-87.

C. McCormick. The inclusions in the Granite of Craftsbury, Vt., 19.—J. Leidy. An Extinct Boar from Florida, 37.—C. Rominger. On the Minute Structure of *Stromatopora* and its allies, 39.—A. Heilprin. Notes on the Tertiary Geology and Palæontology of the Southern United States, 57.—C. Wachsmuth and F. Springer. Revision of the Palæocrinoidea, Part III. Section 2, 64.—F. L. Harvey. On *Anthracomartus trilobitus*, Scud., 231.—A. H. Smith. The Railway-Cutting at Grant's Ferry Road, 253.—J. Leidy. *Toxodon* and other remains from Nicaragua, C. A., 275.—A. E. Foote. The Opal-Mines of Queretaro, Mexico, 278.—G. A. Koenig. Mineralogical Notes, 281.—L. Woolman. Oriskany Sandstone in Lycoming Co., Pa., 296.—G. A. Koenig. Manganese-Zinc Serpentine from Franklin, N. J., 350.—A. Heilprin. On Miocene Fossils from Southern New Jersey, 351.—C. S. Dolley. On the Helictites of Luray Cave, 351.—G. A. Koenig. On Schorlomite as a variety of Melanite, 355.—H. F. Osborn. Observations upon the Upper Triassic Mammals, *Dromatherium* and *Microconodon*, 359.—F. A. Genth. On an undescribed Meteoric Iron from East Tennessee, 366.

———. American Philosophical Society. Proceedings. Vol. xxiii. Nos. 123 & 124. 1886.

J. C. Branner. The Glaciation of Parts of the Wyoming and Lackawanna Valleys, 337.—E. D. Cope. On two new Species of Three-toed Horses from the Upper Miocene, with Notes on the Fauna of the *Ticholeptus*-beds, 351.—A. S. Packard. Discovery of the Thoracic Feet in a Carboniferous Phyllocaridan, 380.—P. Frazer. Sketch of the Geology of York County, Pennsylvania, 391.

Photographic Society of Great Britain. Journal and Transactions. N. S. Vol. x. No. 9. 1886.

———. ———. ———. Vol. xi. Nos. 1-8. 1886-87.

Physical Society of London. Proceedings. Vol. viii. Parts 1-4. 1886-87.

Pisa. Società Toscana di Scienze Naturali. Atti. Memorie. Vol. viii. Fasc. 1. 1886.

G. Meneghini. *Goniodiscus Ferrazzii*, Mgh., nuova stelleride terziaria del Vicentino, 1.—C. de Stefani. Lias inferiore ad Arieti dell' Apennino settentrionale, 9.—A. de Gregorio. Intorno a un deposito di Roditori e di Carnivori sulle vette di Monte Pellegrino con uno schizzo sincronografico del calcare postpliocenico della Vallata di Palermo, 217.

———. ———. ———. Processi Verbali. Vol. v. Pp. 79-226. 1886-87.

L. Busatti. Sulla trachite della Tolfa, 96.—B. Lotti. Brevi considerazioni sulle trachiti della Tolfa, 99.—A. D'Achiardi. Rocce ottrelitiche delle Alpi Apuane, 110.—G. Ristori. Sui depositi quaternari del Casentino, 114.—G. Ristori. Filliti dei travertini Toscani, 114.—B. Lotti. Metamorfismo di sedimenti cretacei, 140.—B. Lotti. Origine della peridotite, 141.—D. Pantanelli. I cosiddetti ghiacciai apenninici, 142.—G. Meneghini. Sulla fauna del Capo di S. Vigilio illustrata dal Vacek, 152.—M. Canavari. Rilevamento geologico della Sibilla, 162.—V. Simonelli. Echinodermi fossili di Pianosa, 163.—C. De Stefani. Gli schisti cristallini dell' Apennino Savonese, 173.—C. De Stefani. Il piano pontico sui monti della Tolfa, 175.—G. Grattarola. Cerussite di Val Fontana, media Valtellina, 177.—M. Canavari. Di alcuni tipi di

foraminifere appartenenti alla famiglia delle Nummulinidæ raccolti nel Trias delle Alpi Apuane, 184.—M. Canavari. Fossili titoniani nel Monte Pisano, 187.—G. Gioli. Fossili della Oolite di San Vigilio, 195.—D. Pantanelli. La *Melania curvirostra*, Desh., dell' Abissinia, 204.—C. De Stefani. I depositi glaciali nell' Apennino di Reggio e di Modena, 206.—G. Ristori. I dintorni d' Orciatico in provincia di Pisa, 212.—G. Ristori. Filliti nei Travertini delle Sugherelle presso Rio (Isola D'Elba), 217.

Plymouth. Devonshire Association for the Advancement of Science, Literature, and Art. Report and Transactions. Vol. xviii. 1886.

W. Pengelly. Happaway Cavern, Torquay, 161.—A. Somervail. The Physiography of Torquay: the geological structure and origin of its Hills and Valleys, 171.—W. Downes. Geological Notes on the Honiton District, 181.—W. Pengelly. Notes on Notices of the Geology and Palæontology of Devonshire, 488.

———. ———. ———. Extra Volume. The Devonshire Domesday. Part 3. 1886. 8vo.

Plymouth Institution and Devon and Cornwall Natural History Society. Annual Report and Transactions. Vol. ix. Part 2 (1885–86). 1886.

R. N. Worth. The Rocks of Plymouth, 213.

Quekett Microscopical Club. Journal. Ser. 2. Vol. ii. No. 16. 1886.

E. Grove and G. Sturt. On a Fossil Marine Diatomaceous Deposit from Oamaree, New Zealand, 321.

———. ———. ———. Vol. iii. Nos. 17 & 18. 1887.

E. Grove and G. Sturt. On a Fossil Marine Diatomaceous Deposit from Oamaree, 7, 63.

Record of Zoological Literature. (Zoological Record.) Edited by A. C. L. G. Günther, A. Newton, E. C. Rye, and F. J. Bell. 1864–1885. Vols. i.–xxii. 8vo. London, 1865–1886. *Purchased.*

Rio de Janeiro. Museum Nacional. Archivos. Vol. i. (1876). 1876.

———. ———. ———. Vol. ii. (1877). 1877.

O. A. Derby. Contribuições para a Geologia de Região do Baixo Amazonas, 77.

———. ———. ———. Vol. iii. (1878). 1878.

H. Gorceix. Estudos geologicos e mineralogicos sobre algumas localidades da Provincia de Minas Geraes, 9.—L. Dupré, Jun. Estudo geologico e mineralogico da região E. de Ouro-Preto, comprehendida entre aquella cidade, a provação do Taquaral e o rio do Carmo, 11.—L. A. Correa da Costa. Estudo geologico de região de S. Bartholomeu e da mina de Ouro da Tapéra perto de Ouro-Preto, 17.—O. A. Derby. A geologia da Região Diamantifera da Provincia do Paraná, 89.—O. A. Derby. A Bacia Cretacea da bahia de Todos os Santos, 135.—R. Rathbun. Observações sobre a geologia aspecto da Ilha de Itaparica, na bahia de Todos os Santos, 159.

———. ———. ———. Vol. iv. (1879). 1881.

O. A. Derby. Contribuição para o estudo da geologia do Valle do Rio S. Francisco, 87.—O. A. Derby. Observações sobre algumas rochas Diamantiferas da Provincia de Minas Geraes, 121.

- Rio de Janeiro. Museum Nacional. Archivos. Vol. v. (1880). 1881.
- . ———. ———. Vol. vi. (1885). 1885.
- Rochester Naturalist. No. 12. 1886. 8vo. *Presented by W. Whitaker, Esq., F.G.S.*
- C. Bird. The Chalk, 204.
- Rome. Reale Accademia dei Lincei. Atti. Serie 3. Memorie. Vol. xviii. 1884.
- C. De Stefani. Escursione scientifica nella Calabria (1877-78), Jejo, Montalto e Capo Vaticano, 3.—G. Capellini. Il Chelonio veronese (*Protosphargis veronensis*, Cap.) scoperto nel 1852 nel Cretaceo superiore presso Sant' Anna di Alfaedo in Valpolicella, 291.
- . ———. ———. ———. ———. Vol. xix. 1885.
- F. Sansoni. Sulle forme cristalline della calcite di Andreasberg (Hartz), 450.
- . ———. ———. Serie 4. Memorie. Vol. i. (1884-85). 1885.
- G. Strüver. Contribuzione alla mineralogia dei vulcani Sabatini, Parte I., 3.—G. Capellini. Del Zifioide fossile (*Choneziphus planirostris*) scoperto nelle sabbie plioceniche di Fangonero presso Siena, 18.—C. De Stefani. Studi paleozoologici sulla creta superiore e media dell' Apennino settentrionale, 73.—G. Pouzi. Conglomerato del Tavolato, 349.
- . ———. ———. ———. ———. Vol. ii. 1885.
- A. Cossa. Sulla vita ed i lavori scientifici di Quintino Sella, 5.—Lavori di Quintino Sella, 45, 225.
- . ———. ———. ———. Rendiconti. Vol. ii. Semestre 1. Fasc. 12-14. 1886.
- F. Keller. Sulle rocce magnetiche di Rocca di Papa, 428.—G. Strüver. Forsterite di Baccano, 459.—E. Mattiolo. Intorno ad alcune rocce della valle del Penna nell' Apennino ligure, 502, 643.—D. Lovisato. Sopra il granito a sferoidi di Ghistorrai presso Fonni in Sardegna, 507.—E. Stassano. La foce del Congo, 510.
- . ———. ———. ———. Rendiconti. Vol. ii. Semestre 2. Fasc. 1-5, 7-12. 1886.
- A. Piccini. Su di un minerale che accompagna la columbite di Cravoggia in Val Vigezzo, 46.
- . ———. ———. ———. Rendiconti. Vol. iii. Fasc. 1-9. 1887.
- G. Seguenza. Gli strati con *Rhynchonella Berchta*, Oppel, presso Taormina, 10.—F. Giacomelli. Sul terremoto del 29 agosto, 1886, 20.—G. Seguenza. I calcari con *Stephanoceras* (*Sphæroceras*) *Brongniartii*, Sow., presso Taormina, 186.
- . Società Geologica Italiana. Bollettino. Vol. i. (1882). 1882-83.
- Estratto della conferenza sulle serpentine, 14.—T. Sterry Hunt. Riasunto della conferenza, 32.—G. B. Chancourtois. Sulle serpentine, 39.—L. Nicotra. Diatomæ in schistis quibusdam messanensibus detectæ, 45.—F. Molon. I colli berici del Vincentino, 47.—T. Taramelli. Osservazioni geologiche nel raccogliere alcune campioni di Serpentine, 80.—D. Pantanelli. Fauna miocenica a radiolarie dell' Apennino settentrionale, 142.—G. Mazzetti. Relazione intorno al modo di formazione

delle argille scagliose di Montese, 156.—A. De Zigno. Resti di Sauriani nel Lombardo-Veneto, 161.—E. Nicolis. Note di geologia Veronese, 162.—C. De Stefani. Osservazioni sulla carta geologica d'Italia pubblicata in occasione del Congresso di Bologna, 165.—T. Taramelli. Osservazioni fatte nei monti circostanti al passo del Sempione, 183.—T. Taramelli. Osservazioni fatte nell'Apennino di Piacenza, 189.—A. Verri. Trasformazioni idrografiche nel territorio di Rieti e Terni, 191.—I. Cafici. Contribuzione alla fauna cretacea Italiana, 196.—R. Arturo. La provincia di Treviso, 203.—A. Issel. Antiche linee litorali della Liguria, 222.—C. Segrè. Appunto geognostico sulle rocce calcareo-magnesiache, che costeggiano il Velino vicino al paese di Antrodoto, 233.—C. F. Parona. Sopra i lembi pliocenici situati tra il bacino del lago d'Orta e la val Sesia, e sull'altopiano di Boca e di Maggiora, 239.

Rome. Società Geologica Italiana. Bollettino. Vol. ii. (1883). 1883-84.

G. A. Tuccimei. Sulla struttura e i terreni che formano la catena di Fara in Sabina, 16.—A. Verri. Due parole sui tufi leucitici dei vulcani Tirreni, 40.—L. Mazzuoli e A. Issel. Sulla sovrapposizione nella Riviera di ponente di una zona otolitica eocenica ad una formazione otolitica paleozoica, 44.—G. Seguenza. Gli Ostracodi dei periodi terziari e quaternari viventi nel mare di Messina, 57.—T. Taramelli. Dello studio geognostico del suolo agrario in rapporto col proposto censimento dei terreni produttivi del regno d'Italia, 84.—G. Uzielli. Sulle argille scagliose, 95.—A. Verri. Sui bacini del Chiascio e del Topino, 108.—C. Segrè. Sulla costituzione geologica dell'Apennino Abruzzese, 121.—E. Bonardi. Analisi chimica di alcune argille glaciali e plioceniche dell'Alta Italia, 126.—G. Uzielli. Sulle ondulazioni terrestri in relazione con l'orografia degli Apennini e delle Alpi, 138.—A. Neviani. Di un orizzonte a Sestarie nel Bolognese, 164.—T. Taramelli. Sulla necessità di studiare le sponde del bacino Adrio-padano, 167.—E. Nicolis. Sul terziario nelle Prealpi retiche ad oriente del lago di Garda, 171.—C. Fornasini. Nota preliminare sui foraminiferi della marna pliocenica del Ponticello di Savena nel Bolognese, 176.—G. Mazzetti. Della stratificazione delle argille scagliose di Montese e dell'analogia che passa fra alcuni lembi di terreno di Costa de' Grassi nel Reggiano ed alcuni affioramenti di S. Martino e di Ranocchio nel Modenese, 190.—F. Salmoiraghi. Sulla galleria abbandonata di Majolungo in Calabria Citeriore, 193.—L. Gatta. Su alcuni fenomeni fisici relativi all'isola d'Ischia, 210.—A. Negri. Studi sulle Alpi Vicentine, 223.—M. Canavari. Relazione del'escursione fatte il 3 e 4 settembre, 1883, alla grotta di Frasassi e al ponte della Rossa nei dintorni di Fabriano, 229.—V. Simonelli. Il monte della Verna e i suoi fossili, 235.—E. Olivero. Orografia dell'Apennino, 284.

———. ———. ———. Vol. iii. (1884). 1884.

A. Verri. La Creta e l'Eocene nel bacino del Tevere, 18.—C. De Stefani. Sugli studi dell'Ufficio geologico nelle Alpi Apuane e nell'Apennino, 23.—A. Alberti. Dal Garda agli Euganei. Saggio di meccanica stratigrafica, 41.—G. Ponzi. Di un grande osso fossile rinvenuto nei contorni di Roma, 66.—R. Meli. Molluschi terrestri e d'acqua dolce rinvenuti nel tufo litoide della Valchetta presso Roma, 71.—C. Fornasini. I Foraminiferi della Tabella *Oryctographica*, 85.—A. Verri. Di alcune divergenze col dott. Carlo de Stefani sulla geologia dell'Umbria superiore, 95.—A. Verri. Divisione tra le formazioni Liasiche, Giuresi e Cretacee nei monti dell'Umbria, 109.—A. Verri. La valle superiore del Tevere, 114.—A. Rossi. Note illustrative alla carta geologica della provincia di Treviso, 131.—A. Neviani. Note geologiche sul bacino del Samoggia nel Bolognese, 161.

Rome. Società Geologica Italiana. Bollettino. Vol. iv. (1885). 1886.

E. Nicolis e C. F. Parona. Note stratigrafiche e paleontologiche sul Giura superiore della Provincia di Verona, 1.—L. Foresti. Sul *Pecten hystrix* Döderl.-Meli. 97.—C. Fornasini. Textularina ed altri foraminiferi fossili nella marra miocenica di S. Rufillo presso Bologna, 102.—F. Salmoiraghi. Le piramidi di erosione ed i terreni glaciali di zone. Contribuzione alla geologia neozoica del Lago d'Iseo, 117.—F. Bassani. Sull'età degli strati a pesci di Castellavazzo nel Bellunese, 143.—G. Riva Palazzi. La Geologia e gli studii geografici, 149.—A. Verri. Appunti per la Geologia dell'Italia centrale, 176.—C. Fornasini. Lagene fossili nell'argilla giallastra di S. Pietro in Lama presso Lecce, 188.—A. Tommasi. Note paleontologiche, 199.—U. Botti. Puglia e Calabria. schizzo geologico, 223.—D. Pantanelli. Il cretaceo di Montese, 232.—T. Taramelli. Note geologiche sul bacino idrografico del fiume Ticino, 239.—T. Tittoni. La regione trachitica dell'Agro Sabatino e Cerite, 337.—G. Seguenza. Le Spiriferina dei vari piani del Lias Messinese, 377.—P. E. De Ferrari. Relazione della escursione fatte alla miniera di lignite di Castelnuovo presso S. Giovanni, Valdarno, 523.

———. ———. ———. Vol. v. Fasc. 1-3 (1886). 1886.

A. Del Prato. Rinoceronte fossile nel Parmense, 20.—C. Fornasini. Il *Nautilus legumen* di Linneo e la *Vaginulina elegans* di d'Orbigny, 25.—A. Neviani. Una sezione geologica da Bazzano a Tiola lungo la rive sinistra del Samoggia, 31.—G. Terrenzi. Sopra un lembo di lias rosso ammonitico rinvenuto nella montagna di Santacroce presso Narni, 39.—G. Seguenza. Del retico al capo di Taormina, 42.—A. Verri. Sui tuffi dei vulcani Tirreni, 46.—A. Verri. Breccia granitica del monte Deruta, 53.—L. Ricciardi. Sulla composizione chimica delle rocce vulcaniche di Assab, 57.—A. Neviani. Sui giacimenti dei cetacei fossili nel Monteleonese con indicazioni di altri rinvenuti nelle Calabrie, 61.—F. Sacco. Il piano Messiniano nel Piemonte, 74.—G. Ristori. I Crostacei brachiuri e anomuri del pliocene italiano, 93.—C. Fornasini. Foraminiferi illustrati da Soldani e citati dagli autori. 131.—C. Fornasini. Di alcune Biloculine fossili negli strati a *Pecten hystrix* del Bolognese, 255.—F. Cavara. Le sabbie marnose plioceniche di Mongardino e i loro fossili, 265.—E. Mariani. Descrizione dei terreni miocenici fra la Scrivia e la Staffora, 277.—F. Cardinali. Sopra un masso di gneiss rinvenuto nelle argille plioceniche dei dintorni di Appignano, 316.—G. Terrenzi. Il pliocene dei dintorni di Narni, 321.—C. Fornasini. Sulla *Glandulina aequalis* di Reuss, 337.—F. Castracane. I tripoli marini nelle valle Metaurense, 343.—C. Fornasini. Varietà di Lagena fossile negli strati a *Pecten hystrix* del Bolognese, 350.—G. Uzielli. Sopra un cranio di Coccodrillo trovato nel Modenese, 355.—F. Sacco. Il piano Messiniano nel Piemonte, 363.—Trottarelli e A. Verri. Notizie geologiche ed analisi chimiche di rocce calcari e di pozzolane nel territorio del bacino del Tevere, 395.—G. Seguenza. Gli strati a *Posidonomya alpina*, Gras, nelle serie giurassica del Taorminese, 402.—H. Pohlig. Sul pliocene di Moragha (Persia) e sugli elefanti fossili della Caucasia e della Persia, 409.—H. Pohlig. Sopra una monografia degli elefanti fossili della Germania e dell'Italia, 413.—A. Verri. Azione delle forze nell'assetto delle valli, con appendice sulla distribuzione dei fossili nella Valdichiana e nell'Umbria interna settentrionale, 416.—A. Issel. Resti di un'antropoide rinvenuti nel pliocene a Pietra Ligure, 455.—B. Lotti. Gabbro od Eufotide?, 460.—A. Verri. Resoconto delle escursioni, 507.

- Royal Agricultural Society. Journal. Ser. 2. Vol. xxii. Part 2. 1886.
- . ———. ———. Vol. xxiii. Part 1. 1887.
- Royal Asiatic Society of Great Britain and Ireland. Journal. N. S. Vol. xviii. Parts 3 & 4. 1886.
- . ———. ———. Vol. xix. Parts 1 & 2. 1887.
- Royal College of Surgeons of England. Calendar, 1886. 1886.
- Royal Geographical Society. Proceedings. Vol. viii. Nos. 7-12. 1886.
- Ardagh. The Red Sea Petroleum Deposits, 502.
- . ———. Vol. ix. Nos. 1-6. 1887.
- E. Naumann. The Physical Geography of Japan, with remarks on the people, 86.
- Royal Institution of Great Britain. Proceedings. Vol. xi. Part 3. No. 80. 1887.
- J. Dewar. Recent Researches on Meteorites, 541.
- Royal Meteorological Society. Quarterly Journal. Vol. xii. Nos. 59-61. 1886-87.
- Royal Microscopical Society. Journal. Ser. 2. Vol. vi. Parts 4-6 A. 1886.
- C. D. Sherborn and F. Chapman. On some Microzoa from the London Clay exposed in the Drainage Works, Piccadilly, London, 1885, 737.
- . ———. ———. 1887. Parts 1-3. 1887.
- Royal Society. Philosophical Transactions, 1885. Vol. clxxvi. Parts 1 & 2. 1886.
- G. J. Hinde. On Beds of Sponge-remains in the Lower and Upper Greensand of the South of England, 403.
- . ———. Vol. clxxvii. Part 1. 1886.
- Sir R. Owen. Description of Fossil Remains, including Foot-bones, of *Megalania prisca*, 327.
- . Proceedings. Vol. xl. Nos. 243-245. 1886.
- H. J. Johnston-Lavis. The Relationship of the Activity of Vesuvius to certain Meteorological and Astronomical Phenomena, 248.—Sir R. Owen. Description of Fossil Remains of two Species of a Megalanian Genus (*Meiolania*, Ow.) from Lord Howe's Island, 315.—F. Rutley. Notes on Alterations induced by Heat in certain Vitreous Rocks, 430.—G. Ansdell and J. Dewar. On the Gaseous Constituents of Meteorites, 549.
- . ———. Vol. xli. Nos. 246-250. 1886-87.
- J. Prestwich. On Underground Temperatures, with Observations of the Conductivity of Rocks; on the Thermal Effects of Saturation and Imbibition; and on a Special Source of Heat in Mountain Ranges, 1.—J. Prestwich. On the Agency of Water in Volcanic Eruptions, with some Observations on the Thickness of the Earth's Crust from a Geological Point of View; and on the Primary Cause of Volcanic Action, 117.—Sir R. Owen. Additional Evidence of the Affinities of the Extinct Marsupial Quadruped *Thylacoleo carnifex*, Ow., 317.

Royal Society. Proceedings. Vol. xlii. Nos. 251-254. 1887.

J. W. Mallett. On the Occurrence of Silver in Volcanic Ash from the Eruption of Cotopaxi of July 22 and 23, 1885. 1.—W. C. Williamson. Note on *Lepidodendron Harcourtii* and *L. fuliginosum*, Will., 6.—W. C. Williamson. On the Organization of Fossil Plants of the Coal-measures: *Heterangium tiliæoides*, Will., and *Kalovylon Hookeri*, 8.—J. W. Hulke. Supplementary Note on *Polacanthus Focci*, describing the Dorsal and some parts of the Endoskeleton imperfectly known in 1881, 16.—H. G. Seeley. On *Proterosaurus Speneri* (Von Meyer), 86.—T. H. Huxley. Preliminary Note on the Fossil Remains of a Chelonian Reptile, *Ceratochelys sthenurus*, from Lord Howe's Island, Australia, 232.—E. Hull. Note on Dr. G. J. Hinde's Paper "On Beds of Sponge-remains in the Lower and Upper Greensand of the South of England," 304.—E. T. Hardman. Note on Professor Hull's Paper, 308.

Rugby. Rugby School Natural History Society. Report for the Year 1886. 1887.

St. Petersburg. Académie Impériale des Sciences. Bulletin. Tome xxx. No. 4. 1886.

F. Schmidt. Ueber einige neue ostsibirische Trilobiten und verwandte Thierformen, 502.

———. ———. ———. Tome xxxi. Nos. 2-4. 1886 & 1887.

N. de Kokcharoff. Mursinskit, nouveau minéral, 450.—C. Zahálka. Sur les *Phymatelles* des couches crétacées en Bohême, 464.—A. Karpinsky. Contributions à la connaissance géologique du gouvernement de Pskow, 473.—A. Karpinsky. Sur quelques roches métamorphiques de l'Oural contenant le graphite et le grenat, 484.

———. ———. ———. Mémoires. Sér. 7. Tome xxxiii. Nos. 6-8. 1886.

E. Mojsisovics von Mojsvár. Arktische Triasfaunen, No. 6.—J. Lahn- sen. Die Inoceramen-schichten an dem Olenek und der Lena, No. 7.—F. Schmidt. Revision der ostbaltischen silurischen Trilobiten, No. 8.

———. ———. ———. Sér. 7. Tome xxxiv. Nos. 1-13. 1886.

A. Stuckenbergh. Materialien zur Kenntniss der Fauna der devonischen Ablagerungen Sibiriens, No. 1.—A. Struve. Ueber die Schichtenfolge in den Carbonablagerungen im südlichen Theil des moskauer Kohlenbeckens, No. 6.—N. v. Kokscharow. Die etwas näheren Bestimmungen der Walnewit-Krystalle von der Grube Nikolaje-Maximilianowsk, No. 10.

———. ———. ———. Sér. 7. Tome xxxv. No. 1. 1887.

Salem. Peabody Academy of Science. 19th Annual Report. 1887.

Sanitary Institute of Great Britain. Transactions. Vol. vii. (1885-86). 1886.

J. D. Paul. On the Valley of the Soar, 261.

School of Mines (Royal). Magazine. Vol. i. No. 3. 1877.
Presented by W. Whitaker, Esq., F.G.S.

———. ———. Vol. ii. Nos. 1 & 2. 1877-78. *Presented by W. Whitaker, Esq., F.G.S.*

C. L. Morgan. The Drift of Brazil, 3.—H. Louis. On the Copper Deposit at New Annan, 66.—W. H. M. Our Isle of Wight Geological Trip, 77.

Scientific News. Vol. i. Nos. 1-5. 1887.

- Shanghai. China Branch of the Royal Asiatic Society. Journal. N. S. Vol. xix. Part 2. 1886.
- . ———. ———. ———. Vol. xx. Nos. 5 & 6. 1885.
- . ———. ———. ———. Vol. xxi. Nos. 1-4. 1886 & 1887.
- Society of Arts. Journal. Nos. 1753-1779. 1886.
- . ———. Nos. 1780-1804. 1887.
- Society of Biblical Archæology. Proceedings. Vol. viii. 1886.
- Society of Medical Officers of Health. Transactions. Session 1885-86. 1886. *Presented by W. Whitaker, Esq., F.G.S.*
- W. Eassie. On the Waters derived from the Bagshot Beds, considered as Drinking Supplies, 122.
- Stettin. Verein für Erdkunde. Jahresbericht, 1886. 1887.
- Stockholm. Geologiska Föreningen. Förhandlingar. Band viii. Häfte 5-7. 1886.
- O. Gumælius. Också et bidrag till historiken öfver de geologiska undersökningarne i Sveriges fjälltrakter, 383.—H. Sjögren. Meddelande om slamvulkanerna i Baku, 416.—A. Sjögren. Mineralogiska notiser, XI., 430.—A. E. Törnebohm. Karakteristik af bergartsprof, insamlade af den svenska expeditionen till Grönland år 1883, 431.—A. E. Nordenskiöld. Mineralogiska bidrag, 442.—Hampus von Post. Kalgranit med bergbeck, 453.—K. Pettersen. Notitser vedrørende den nord-norske fjeldbygning, 459.—M. Hiriakoff. Om ett fynd af qvicksilfvermahn i distriktet Bachmut, guvernementel Jekaterinoslaw, 470.—A. Sjögren. Mineralogiska notiser, XII., 473.—A. Hamberg. Anatas och titanit på rutil från apatitförekomsten vid Kragerö, 475.—L. J. Igelström. Mineralogiska meddelanden, IV. & V., 477.—M. Weibull. Om manganapatit från Vestanå jemte några anmärkningar öfver apatitens sammansättning, 492.—M. Weibull. Om fluoceriten från Osterby i Dalarne, 496.—G. De Geer. Om vindnötta stenar, 501.—T. Fegærus. Sandslipade stenar från Gotska Sandön, 514.—E. Svedmark. Smärre meddelanden, 519.
- . ———. ———. Band ix. Häfte 1-4 (1887). 1887.
- A. G. Högbom. Om sekulära höjningen vid Vesterbottens kust, 19.—A. E. Nordenskiöld. Mineralogiska bidrag, 26.—A. Lacroix. Mikroskopisk undersökning af thaumasit, 35.—T. Nordström. Sveriges malm- och metall-produktion, 1885, 37.—O. Gumælius. Samling af underrettelser om jordstötter i Sverige, 42.—E. Erdmann. Om en djupborring med diamantborr för sokande efter stenkollstillgångar i Schweiz, 58.—B. Santesson. Nickelmalmfyndigheten vid Kiefva, 66.—A. G. Nathorst. Till frågan om de skånska dislokationernas ålder, 74.—E. Bertrand. Thaumasitens optiska egenskaper, 131.—E. Svedmark. Smärre meddelanden, II., 131.—A. Sjögren. Anteckningar i praktisk geognosi, IV., 146.—G. Nordenström. Om användning af diamantborrmaskiner för malmfyndigheters undersökning, 151.—C. W. Blomstrand. Analys af cer- och ytterfosfater från södra Norge, ett bidrag till frågan om dessa mineraliers kemiska byggnad, 160.—E. Svedmark. Orografiska studier inom Roslagen, 188.—H. von Post. Ytterligare om nickelmalmfyndigheten vid Klefva, 215.—A. G. Nathorst. En ny teori om de svenska klippbäckenas uppkomst, 221.—T. Nordström. Om utsträckningen af begreppet malm, 230.—C. A. Vrang. Fynd af svartmalm med starkt

utpräglad magnetism, 243.—W. C. Brögger. Foreløbig meddelelse om mineralerne på de sydnorske augit- og nefelinsyeniters grovkornige gange, 247.—J. Jönsson. Bidrag till kannedomen om våra plastiska lerors användbarhet, 275.—H. Reusch. Om systematisk indsamling af jordskjælvsagttagelser paa den skandinaviske halvö, 279.

Stuttgart. Neues Jahrbuch für Mineralogie, Geologie und Paläontologie, 1886. Band ii. Hefte 2 & 3. 1886.

L. Langemann. Beiträge zur Kenntniss der Mineralien Harmotom, Phillipsit, und Desmin, 83.—B. Stürtz. Ueber paläozoische Seesterne, 142.—N. Andrussow. Ueber zwei neue Isopodenformen aus neogenen Ablagerungen, 155.—J. v. Siemiradzki. Ueber Anorthitgesteine von S. Thomas (Antillen), 175.—K. von Chrustschoff. Ueber einen eigenthümlichen accessorischen Gemengtheil des Granitporphyrs von Beucha und des Phonoliths von Olbrück, 180.—A. Kenngott. Krystallgestalten des Eises: Formel des Manganostibiits, 184.—B. Hecht. Ueber Prismen, welche zur Bestimmung von Brechungsindices durch Totalreflexion dienen sollen, 186.—A. E. Törnebohm. Ueber das Vorkommen nephritartiger Gesteine in Schweden, 191.—E. Haug. Ueber die systematische Stellung der Gattung *Zurcheria*, Douv., 193.—E. W. Benecke. Ueber eine Ophiure aus dem englischen Rhät, 195.—O. Herrmann. Gletscherschliffe auf der nordsächsischen Grauwacke rechts der Elbe, bei Lüttechau zwischen Grossenhain und Zamenz, 200.—S. Nikitin. Ueber die Beziehungen zwischen der russischen und der westeuropäischen Juraformation, 205.—A. von Könen. Ueber neue Cystideen aus den Caradoc-Schichten der Gegend von Montpellier, 246.—A. B. Meyer. Ein dem Nephrit mineralogisch nahestehendes Aktinolithgestein aus der Ryllshytte-Kompani-Grube in Dalecarlien, 255.—A. Cathrein. Petrefactenfunde bei Brixlegg in Tirol, 257.

———. ——, 1887. Band i. Hefte 1-3. 1887.

M. Bauer. Beiträge zur Mineralogie, V., 1.—R. Brauns. Zur Frage der optischen Anomalien, 47.—C. Schmidt. Diabasporphyrite und Melaphyre vom Nordabhang der Schweizer Alpen, 58.—M. Neumayr. Ueber die Beziehung zwischen der russischen und der westeuropäischen Juraformation, 70.—A. Beutell. Ueber Prehnit von Striegau und Jordansmühl in Schlesien, 89.—F. Sandberger. Weite Verbreitung des Jods in Phosphoriten, &c., 95.—A. Streng. Ueber die in den Graniten von Baveno vorkommenden Mineralien, 98.—G. Vom Rath. Ueber den Ausbruch des Tarawera auf Neu-Seeland 10 Juni, 1886, 101.—F. Sandberger. Bemerkungen über den Silbergehalt des Glimmers aus dem Gneisse von Schapbach und des Augits aus dem Diabase von Andreasberg am Harz, 111.—A. Cathrein. Ueber den Proterobas von Leogang, 113.—F. Römer. Ueber H. v. Meyer's *Mastodon Humboldti*, Cuv.?, aus Mexico, 114.—A. Osann. Ueber Azorit und Pyrrhit, 115.—W. Dames. Entgegnung an Herrn Dr. Carl Diener, 116.—P. Choffat. Kreideablagerungen an der Westküste von Südafrika, 117.—C. Cohen. Ueber Speckstein, Pseudophit und dichten Muscovit aus Süd-Africa, 119.—L. Darapsky. Ueber einige chilenische Alaune, 125.—R. Brauns. Ueber Winkelschwankungen isotroper und doppeltbrechender regulärer Krystalle, 138.—A. Cathrein. Beiträge zur Petrographie Tirols, 147.—F. Römer. *Graptocarcinus texanus*, ein Brachyure aus der oberen Kreide von Texas, 173.—R. Häusler. Die Lageninen der schweizerischen Jura- und Kreideformation, 177.—R. Häusler. Bemerkungen über einige liasische Milioliden, 190.—O. Mügge. Ueber "Gelenksandstein" aus der Umgegend von Delhi, 195.—G. Vom Rath. Ueber Cristobalit vom Cerro S. Cristóbal bei Pachuca, Mexico, 198.—C. Klein. Optische Untersuchung zweier Granatvorkommen vom Harz, 200.—F. Graeff. Laavenit im brasilianischen Eläo-

lithsyenit, 201.—H. Trautschold. Ueber Oligocän am Ostabhang des Ural, 203.—K. von Chrustschoff. Ueber gelungene Versuche zur Darstellung des Quarzes auf nassem und des Tridymits auf trockenem Wege, 205.—K. von Chrustschoff. Beweis für den ursprünglich hyalinmagnetischen Zustand gewisser echter Granite und granitartiger Gesteine, 208.—J. Götz. Ueber Andalusit aus den krystallinen Schiefern von Marabastad, Transvaal, 211.—J. Strüver. Ueber Gastaldit und Glaukophan, 213.—B. Hecht. Ueber die Modifikation, welche die Neigung der Grenze der Totalreflexion bei Benutzung der Wollaston'schen Methode durch den Austritt aus dem Prisma erleidet, 218.—C. Ochsenius. Phosphorsäuregehalt des Natronsalpeters, 221.—C. Klein. Beleuchtung und Zurückweisung einiger gegen die Lehre von den optischen Anomalien erhobenen Einwendungen, 223.—F. Sandberger. Ueber einen neuen Pelekypoden aus dem nassauischen Unterdevon, 247.—H. B. Patten. Hornblende, Oligoklas, und Titanit aus Drusenräumen im Schriesheimer Diorit, 261.

Stuttgart. Neues Jahrbuch für Mineralogie, Geologie und Paläontologie, 1887. Beilage-Band iv. Heft 3. 1886.

H. Reusch. Ueber den Tysnesmeteorit und drei andere in Skandinavien niedergefallene Meteorsteine, 473.—H. Schedtler. Experimentelle Untersuchung über das elektrische Verhalten des Turmalins, 519.—O. Mügge. Ueber einige Gesteine des Massai-Landes, 576.—C. Rammelsberg. Ueber die Gruppe des Skapoliths, 610.

———. ———. Beilage-Band v. Heft 1. 1887.

H. Reusch. Geologische Beobachtungen in einem regionalmetamorphosirten Gebiet am Hardangerfjord in Norwegen, 52.—W. Voigt. Bestimmung der Elasticitäts-Constanten von Beryll und Bergkrystall, 68.—J. Bosscha, jun. Ueber den Meteorit von Karang-Modjo oder Magetan auf Java, 126.—E. Cohen. Geognostisch-petrographische Skizzen aus Süd-Afrika, II., 195.

———. Palæontographica. Band xxxii. Lief. 4–6. 1886. *Purchased.*

M. Blanckenhorn. Die fossile Flora des Buntsandsteins und des Muschelkalks der Umgegend von Commern, 117.—J. Walther. Untersuchungen über den Bau der Crinoiden mit besonderer Berücksichtigung der Formen aus dem Solenhofener Schiefer und dem Kelheimer Diceraskalk, 155.—E. Riefstahl. Die Sepienschale und ihre Beziehung zu den Belemniten, 201.—O. Roger. Ueber *Dinotherium bavaricum*, H. v. Meyer, 215.—E. Fraas. Die Asterien des Weissen Jura von Schwaben und Franken mit Untersuchung über die Structure der Echinodermen und das Kalkgerüste der Asterien, 227.

———. ———. Band xxxiii. Lief. 1–6. 1886. *Purchased.*

A. Rothpletz. Geologisch-paläontologische Monographie der Vilser Alpen, mit besonderer Berücksichtigung der Brachiopoden-Systematik, 1.—J. Schmalhausen. Ueber tertiäre Pflanzen aus dem Thale des Flusses Buchtorma am Fusse des Altaigebirges, 181.—G. C. Laube und G. Bruder. Ammoniten der böhmischen Kreide, 217.

Swansea. South-Wales Institute of Engineers. Proceedings. Vol. xiv. No. 6. 1886.

———. ———. Vol. xv. Nos. 1 & 2. 1886.

H. Laporte. Notes on the Coalfields and Coal Industry in Belgium, 68.

- Sydney. Linnean Society of New South Wales. Proceedings.
Vol. x. Part 4. 1886.
- F. Ratte. On some remarkable Crystals of Siderite, 758.
- . ———. ———. Ser. 2. Vol. i. Parts 1-4. 1886-87.
- F. W. Hutton. The Mollusca of the Pareora and Oamaru Systems of New Zealand, 205.—F. W. Hutton. Notes on some Australian Tertiary Fossils, 481.—J. Stirling. On some Further Evidences of Glaciation in the Australian Alps, 483.—W. Stephens. Notes on the Recent Eruptions in the Taupo Zone, New Zealand, 513.—W. Stephens. Note on a Labyrinthodont Fossil from Cockatoo Island, Port Jackson, 931.—F. Ratte. Notes on Australian Fossils, 1064.—W. J. Stephens. On the Biloela Labyrinthodont, 1112.—W. J. Stephens. On some additional Labyrinthodont Fossils from the Hawkesbury Sandstone of New South Wales, 1174.—J. Mitchell. Notes on the Geology of Bowning, N. S. W., 1192.
- . ———. Record of Proceedings, Oct. 31, 1885. 8vo. 1886?
- . Royal Society of New South Wales. Journal and Proceedings for 1885. Vol. xix. 1886.
- H. C. Russel. Presidential Address, 1.—H. C. Russel. Local Variations and Vibrations of the Earth's Surface, 51.—S. H. Cox. Notes on the Characters of the Adelong Reefs, 135.
- Tokio. College of Science, Imperial University, Japan. Journal.
Vol. i. Part 1. 1886.
- B. Kotô. A Note on Glaucofane, 85.
- . ———. ———. Vol. i. Part 2. 1887.
- . Imperial University of Japan (Teikoku Daigaku). The Calendar for the Year 1886-87. 1886.
- . Seismological Society of Japan. Transactions. Vol. ix. Parts 1 & 2. 1886.
- C. G. Knott. Earthquake Frequency, 1 (part 1).—John Milne. The Volcanoes of Japan, 1 (part 2).
- . ———. ———. Vol. x. 1887.
- J. Milne. On a Seismic Survey made in Tokio in 1884 and 1885, 1.—J. Macgowan. Earthquakes in China, 37.—T. W. Kingsmill. Notes to accompany some Theorems in the Dynamics of Geology, 47.—Seikei Sekiya. Earthquake Observations of 1885 in Japan, 57.—Seikei Sekiya. Catalogue of 482 Earthquakes in 1885, 65.—Earthquake Catalogues for 1881-85, 83.—Catalogue of Earthquakes (May 1885 to January 1887), 97.
- Toronto. Canadian Institute. Proceedings. Series 3. Vol. iv. Fasc. 1. 1886.
- T. N. Dale. New England Upper Silurian, 69.—A. C. Lawson. Gneissic Foliation, 115.
- Toulouse. Société d'Histoire Naturelle. Bulletin Trimestriel. 19^e Année (1885). 1886. Sheets 15-22, concluding the vol.
- . ———. ———. 20^e Année (1886), Jan.-Déc. 1886.
- J. Kühn. Recherches sur les Ophites des Pyrénées, 163.

Turin. Reale Accademia delle Scienze. Atti. Vol. xxi. Disp. 3, 4. 1886.

———. ———. ———. Vol. xxi. Disp. 6, 7. 1886.

E. Mattiolo. Sulla Natrolite di Montecatini, Val di Cecina, 848.—F. Sacco. Intorno ad alcune impronte organiche dei terreni terziari del Piemonte, 927.

———. ———. ———. Vol. xxii. Disp. 1–11. 1887.

G. Spezia. Sulla fusibilità dei minerali, 419.—F. Sacco. Studio geologico dei dintorni di Voltaggio, 613.

———. ———. Memorie. Serie 2. Tomo xxxvii. 1886.

L. Bellardi. I Molluschi dei terreni terziari del Piemonte e della Liguria, Parte iv., 3.—F. Sacco. Fauna malacologica delle alluvioni plioceniche del Piemonte, 169.—A. Portis. Catalogo descrittivo dei Talassoterii rinvenuti nei terreni terziari del Piemonte e della Liguria, 247.—A. de Gregorio. Fossili del Giura-Lias (Alpiniano, De Greg.) di Segan e di Valpore (Cima d'Asta e Monte Grappa), 451.—A. de Gregorio. Nota intorno a taluni fossili de Monte Erice di Sicilia del piano Alpiniano, De Greg. (=Giura-Lias auctorum), e precisamente del sottorizzonte Grappino, De Greg., ecc., 665.

———. Osservatorio della Regia Università. Bollettino. Anno 20, 1885. 1886.

University College Calendar, Session 1886–87. 1886.

Victoria Institute. Journal of the Transactions. Vol. xx. Nos. 78–80. 1886–87.

———. ———. Vol. xxi. No. 81. 1887.

E. Hull. Notes on some of the Results arrived at by Members of the Expedition sent out by the Committee of the Palestine Exploration Fund, in 1883–84, to Arabia Petræa and Western Palestine, 11.

Vienna. Beiträge zur Paläontologie Oesterreich-Ungarns und des Orients. Band v. Heft 3. 1886. *Purchased.*

F. Wähler. Beiträge zur Kenntniss der tieferen Zonen des unteren Lias in den nordöstlichen Alpen, 57.—A. v. Alth. Ueber die Zusammengehörigkeit der den Fischgattungen *Pteraspis*, *Cyathaspis*, und *Scaphaspis* zugeschriebenen Schilder, 61.

———. Kaiserliche Akademie der Wissenschaften. Anzeiger, 1886. Nos. 15–27. 1886.

C. v. Ettingshausen. Beiträge zur Kenntniss der Tertiärflora Australiens, 177.

———. ———. ———, 1887. Nos. 1–8. 1887.

C. v. Ettingshausen. Beiträge zur Kenntniss der fossilen Flora Neuseelands, 1.—M. Wilckens. Ueber ein Fossiles Pferd Persiens, 42.—F. Becke. Ätzversuche am Pyrit, 45.

———. ———. Denkschriften. Band 1. 1885.

Abtheilung I.

C. v. Ettingshausen. Die fossile Flora von Sagor in Krain, 1.—M. Neumayr. Die geographische Verbreitung der Juraformation, 57.

Abtheilung II.

F. Toula. Geologische Untersuchungen in der "Grauwackenzone"

der nordöstlichen Alpen, 121.—G. Bruder. Die Fauna der Jura-Ablagerung von Hohnstein in Sachsen, 233.—F. Toulou und J. A. Kail. Ueber einen Krokodil-Schädel aus den Tertiärablagerungen von Eggenberg in Niederösterreich, 299.

Vienna. Kaiserliche Akademie der Wissenschaften. Sitzungsberichte. Mathematisch-naturwissenschaftliche Classe, 1884. Band xci. Heft 5 (1885). 1885.

———. ———. ———. ———, 1885. Band xcii. Hefte 1–5 (1885). 1885–86.

C. Prohaska. Ueber den Basalt von Kollnitz im Lavantthale und dessen glasige cordieritführende Einschlüsse, 20.—C. W. C. Fuchs. Statistik der Erdbeben von 1865–85, 215.—C. Diener. Die Structur des Jordanquellgebietes, 633.—C. Zahálka. Ueber *Isoraphinia texta*, Röm. sp., und *Scytalia pertusa*, Reuss sp., aus der Umgebung von Raudnitz a. E. in Böhmen, 647.

———. ———. ———. ———, Band xciii. Hefte 1–3 (1886). 1886.

G. Bruder. Neue Beiträge zur Kenntniss der Juraablagerungen im nördlichen Böhmen, 193.

———. K.-k. Bergakademien zu Leoben und Příbram und der königlich-ungarische Bergakademie zu Schemnitz. Berg- und Hüttenmännisches Jahrbuch. Band xxxiv. Hefte 2–4. 1886.

De Charcourtois, Lallemant, und Chesneau. Ueber das Studium der Bewegungen der Erdrinde mit Rücksicht auf deren Beziehungen zum Auftreten schlagender Wetter, 298.

———. ———. ———. Band xxxv. Heft 1. 1887.

———. K.-k. geologische Reichsanstalt. Abhandlungen. Band xii. Nos. 1–4. 1886. (New vol. xii.)

L. Tausch. Ueber die Fauna der nicht marinen Ablagerungen der oberen Kreide des Csingerthales bei Ajka im Bakony (Veszprimer Comität, Ungarn) und über einige Conchylien der Gosaumergel von Aigen bei Salzburg, 1.—D. Stur. Beitrag zur Kenntniss der Flora des Kalktuffes und der Kalktuff-Breccie von Hötting bei Innsbruck, 33.—M. Vacek. Ueber die Fauna der Oolithe von Cap S. Vigilio, verbunden mit einer Studie über die obere Liasgrenze, 57.—G. Geyer. Ueber die liasischen Cephalopoden des Hierlatz bei Hallstadt, 213.

———. ———. Jahrbuch, 1886. Band xxxvi. Hefte 2–4. 1886.

J. Walther. Vulcanische Strandmarken, 295.—A. H. Schindler. Die Gegend zwischen Sabzwár und Mesched in Persien, 303.—F. Lowl. Spalten und Vulcane, 315.—F. von Hauer. Bemerkung zu Dr. A. Brezina's Abhandlungen: Die Meteoritensammlung des k.-k. mineralogischen Hofcabinetes in Wien am 1. May, 1885, 326.—C. von John und H. B. von Foullon. Arbeiten aus dem chemischen Laboratorium der k.-k. geologischen Reichsanstalt, 329.—F. Frech. Ueber ein neues Liasvorkommen in den Stubai-Alpen, 355.—H. Zapalowicz. Eine geologische Skizze des östlichen Theiles der Pokutisch-Marmaroscher Grenzkarpathen, 361.—S. Polifka. Beitrag zur Kenntniss der Fauna des Schlern-Dolomites, 595.—H. Sjögren. Beiträge zur Kenntniss der Erzlagerstätten von Moravica und Dognacska im Banat und Vergleichung derselben mit den schwedischen Eisenerzlagerstätten, 607.—J. v. Siemiradzki. Studien im pölnischen Mittelgebirge, 669.—E. Tietze. Beiträge

zur Geologie von Galizien, 681.—F. Toula. Geologische Notizen aus dem Triestingthale, 699.—F. Teller. Ueber porphyritische Eruptivgesteine aus den Tiroler Central-Alpen, 715.—H. v. Foullon. Ueber Porphyrite aus Tirol, 747.

Vienna. K.-k. geologische Reichsanstalt. Verhandlungen, 1886. Nos. 7–18. 1886.

G. C. Laube. Ueber böhmische Kreide-Ammoniten, 152.—J. Blaas. Ein Beitrag zu den "pseudoglacialen" Erscheinungen, 155.—E. v. Mojsisovics. Vorlage des Werkes "Arktische Triasfaunen," 155.—F. Wähler. Zur heteropischen Differenzirung des alpinen Lias, 168, 190.—J. N. Woldřich. Paläontologische Beiträge, 176.—L. v. Tausch. Ueber die Beziehungen der Fauna der nicht-marinen Kreidebildungen von Ajka im Bakony zu jener der Laramiebildungen Nord-Amerikas, 180.—F. Toula. Mittelneocom am Nordabhange des grossen Flösselberges bei Kaltenleutgeben, 189.—C. v. John. Ueber die Andesite von Rzegocina und Kamionna bei Bochnia in Westgalizien, 213.—H. Lechleitner. Die Kreide von Pletzsch (Ladoi) auf dem Sonnenwendjoch bei Brixlegg, 215.—K. F. Fraunscher. Geologisches aus Egypten, 216.—K. von Chrustschoff. Mikrolithologische Mittheilungen, 230.—C. M. Paul. Aufnahmebericht aus der Gegend zwischen Bielitz-Biala und Andrychau, 239.—V. Uhlig. Reisebericht aus der Gegend von Teschen und Saybusch, 240. L. v. Tausch. Reisebericht aus Saybusch, 241.—A. Bittner. Aus den Umgebungen von Windischgarsten in Oberösterreich und Palfau in Obersteiermark, 242.—G. Geyer. Ueber das Sengsengebirge und deren nördliche Vorlagen, 247.—H. Lechleitner. Zur Rofangruppe, 257.—H. Lechleitner. Das Sonnenwendjochgebirge bei Brixlegg, 261.—E. Palla. Recent Bildung von Markasit in Inkrustationen im Moore von Marienbad, 266.—F. Teller. Die silurischen Ablagerungen der Ost-Karawanken, 267.—R. Scharizer. Der erste österreichische Monazitfund, 283.—C. M. Paul. Aufnahmebericht aus der Gegend zwischen Bielitz und Teschen, 284.—F. Teller. Ein Zinnoberführender Horizont in den Silur-Ablagerungen der Karawanken, 285.—C. v. Camerlander. Reisebericht aus Westschlesien, 294.—A. Cathrein. Zur Gliederung des rothen Sandsteines, 307.—A. Pichler. Vom Sonnenwendjoch, 311.—V. Uhlig. Reisebericht aus der Karpathensandstein-Zone Schlesiens, 315.—L. v. Tausch. Reisebericht aus der Gegend von Saybusch, 317.—F. Römer. Ueber einen bemerkenswerthen Fund von Granat-Krystallen auf der Dominsel in Breslau, 328.—F. Sandberger. Bemerkungen über fossile Conchylien aus dem Susswasserkalke von Leobersdorf, 331.—C. v. Camerlander. Reisebericht aus Westschlesien, 332.—M. Neumayr. Juraablagerungen von Waidhofen an der Ybbs, 348.—E. Döll. Ueber einen Riesenpegmatit bei Pisek, 351.—E. Döll. Pyrit nach Turmalin, eine neue Pseudomorphose, 355.—C. v. Camerlander. Ein Korundvorkommen in nordwestlichen Schlesien, 356.—C. W. v. Gümbel. Kurze Bemerkung über die Nummulitenschichten am Nordrande der Alpen, 367.—F. Herlich. Ueber Kreidebildungen der siebenbürgischen Ostkarpathen, 368.—A. Bittner. Die neuesten Wandlungen in den modernen Ansichten über Gebirgsbildung, 374.—D. Stur. Vorlage des ersten fossilen Schädels von *Ceratodus* aus den obertriadischen Reingrabner Schiefen von Pölzberg nördlich bei Lunz, 381.—D. Stur. Obercarbonische Pflanzenreste vom Bergbau Reichenberg bei Assling in Oberkrain, 383.—G. Stache. Ueber das Alter von bohnerzführenden Ablagerungen am "Monte Promina" in Dalmatien, 385.—A. Bittner. Neue Petrefactenfunde im Werfener Schiefer der Nordostalpen, 387.—G. Bukowski. Mittheilung über eine neue Jodquelle in der miocänen Randzone der Karpathen und über Algenfunde in den wasserführenden Schichten. 391.—F. Sandberger. Die fos-

silen Binnen-Conchylien des Hornsteins von Dukovan bei Oslawan in Mähren, 403.—F. Toula. Ueber ein neues Vorkommen von Kalkes der sarmatischen Stufe am Thebener Kogel, 404.—F. Toula. Ueber das Vorkommen von Congerien-schichten am Hundsheimerberge zwischen Hundsheim und Hainburg, 405.—A. Rzehak. Die Conchylienfauna des marinen Sandes von Rebeschowitz in Mähren, 406.—J. N. Woldřich. Zur diluvial Fauna der Stramberger Höhlen, 407.—A. M. Lomnicki. Die tertiäre Süßwasserbildung in Ostgalizien, 412.—D. Stur. Vorlage der von Dr. Wähler aus Persien mitgebrachten fossilen Pflanzen, 431.—E. Tietze. Beiträge zur Geologie von Galizien, 436.—V. Uhlig. Ueber ein Juravorkommen vom Berge Holikopetz bei Koritschan im mährischen Marsegebirge, 436.—V. Goldschmidt. Ueber das specifische Gewicht von Mineralien, 439.—A. Bittner. Ueber die weitere Verbreitung der Reichenhallen Kalke in den nordöstlichen Kalkalpen, 445.—A. Hofmann. Vorläufige Mittheilung über neuere Funde von Säugethierresten von Göriach, 450.—J. N. Woldřich. Ueber das Vorkommen einiger Mineralien in Südböhmen, 453.—M. Vacek. Ueber die geologischen Verhältnisse des Flussgebietes der unteren Mürz, 455.—H. B. v. Foullon. Ueber neu eingelangte Minerale, 464.

Vienna. K.-k. geologische Reichsanstalt. Verhandlungen, 1887. Nos. 1–8. 1887.

F. Römer. Nachträglichen Daten zu dem Granatenfunde auf der Dominsel, 42.—G. Gürich. Einschlüsse von geröllartiger Form aus Steinkohlenflötzen von Oberschlesien, 43.—F. v. Sandberger. Bemerkungen zu den neueren Veröffentlichungen Lomnicki's über die tertiären Brack- und Süßwasserbildungen Galiziens, 45.—A. Pichler. Zur Geologie der Kalkgebirge südlich von Innsbruck, 45.—G. C. Laube. Pinitführender Granitporphyr von Raitzenhain, 47.—L. Teisseyre. Notiz über einige seltenere Ammoniten der Boliner Oolithe, 48.—F. Kraus. Ueber Dolinen, 54.—C. M. Paul. Geologische Karte der Gegend zwischen Andrychau und Teschen, 63.—E. Tietze. Ueber recente Niveauveränderungen auf der Insel Paros, 63.—C. v. Camerlander. Zur Geologie des Granulitgebietes von Prachatitz, 66.—E. Tietze. Noch ein Wort zu Dr. Diener's Libanon, 77.—A. Bittner. Zur Verbreitung der Opponitzer Kalke in den nordsteirischen und in den angrenzenden oberösterreichischen Kalkalpen, 81.—A. Cathrein. Ueber Augitporphyr von Pillersee, 86.—A. Rzehak. Die Foraminiferenfauna des grünen Oligocänthones von Nikoltzschitz in Mähren, 87.—A. Bittner. Aus dem Gebiete der Ennsthaler Kalkalpen und des Hochschwab, 89.—G. C. Laube. Notiz über eine eigenthümliche Biegung des Muskowitzgneisses auf der Ruine Hassenstein bei Kaaden, 133.—A. Rzehak. Die Foraminiferenfauna des blauen Oligocänthones von Nikoltzschitz in Mähren, 133.—E. Palla. Zur Frage der Palmennatur der *Cyperites*-ähnlichen Reste aus der Höttinger Breccie, 136.—A. Penck. Die Höttinger Breccie, 140.—F. Teller. Die Aquivalente der dunklen Orthoceren-Kalke des Kok im Bereiche der Silurbildungen der Ost-Karawanken, 145.—H. Sjögren. Ueber die petrographische Beschaffenheit des eruptiven Schlammes von den Schlammvulcanen der Kaspischen Region, 165.—D. Stur. Aussprache an die geehrten Anwesenden aus Veranlassung der glücklichen Rückkehr des Collegen Herrn Prof. Dr. O. Lenz von seiner dritten Afrikareise, 170.—D. Stur. Vorlage der Calamarien der Carbon-Flora der Schatzlarer Schichten, 171.—H. B. v. Foullon. Ueber die Zusammensetzung einer accessorischen Bestandmasse aus dem Piseker Riesenpegmatit, 150.—M. Vacek. Ueber einige Pachydermenreste aus den Ligniten von Kentschach in Kärnten, 156.—V. Uhlig. Ueber Neocom vom Gardenzazza-Stock in Sudtiro, 156.—C. v. Camerlander. Aus dem Granitgebiete von Friedeberg in Schlesien, 157.—F

Becke und M. Schuster. Geologische Beobachtungen im Altvatergebirge, 109.—M. Vacek. Ueber neue Funde von Mastodon aus den Alpen, 120.—C. von Camerlander. Vorlage von Mittheilungen Herrn Dr. H. Sjögren's über das transkaspische Naphtagebiet, 123.—G. Geyer. Bericht über die geologischen Aufnahmen auf dem Blatte Kirchdorf in Oberösterreich, 124.—C. J. Wagner. Ueber die Wärmeverhältnisse in der Osthälfte des Arlbergtunnels, 185.—F. Wähner. Ueber die stratigraphische Beziehungen des Alpen-Lias zum Dachsteinkalk, 186.—L. v. Tausch. Einiges über die Fauna der grauen Kalke der Südalpen, 187.

Vienna. K.-k. naturhistorische Hofmuseums. Annalen. Band i. Nos. 3-4. 1886.

A. Gehmacher. Goldsand mit Demantoid vom alten Ekbatana und Hamadan, 233.—R. Köchlin. Ueber ein neues Euklas-Vorkommen aus den österreichischen Tauern, 237.

———. ———. ———. Band ii. Nos. 1 & 2. 1887.

E. Pergens. Pliocäne Bryozoen von Rhodos, 1.—N. Andrussou. Eine fossile *Acetabularia* als gesteinsbildender Organismus, 77.—R. Köchlin. Ueber Phosgenit und ein muthmässig neues Mineral vom Laurion, 185.

———. Mineralogische und petrographische Mittheilungen. N. F. Band vii. Heft 6. 1886. *Purchased.*

B. Doss. Die basaltischen Laven und Tuffe der Provinz Haurân und vom Dîret-et Tulûl in Syrien, 461.—C. Dölter. Synthese und Zusammensetzung des Pyrrhotin, 535.

———. ———. ———. Band viii. Hefte 1-5. 1886-86. *Purchased.*

C. Klement. Analysen einiger Mineralien und Gesteine aus Belgien, 1.—C. Fuchs. Die vulcanischen Ereignisse des Jahres 1885, 21 Jahresbericht, 28.—F. Eigel. Ueber einige trachytische Gesteine von der Insel San Pietro, 62.—F. Eigel. Ueber einige Eruptivgesteine der Pontinischen, 73.—C. von Vogdt. Diabasporphyrit aus der Umgegend der Stadt Petrosawodsk im Plonitzer Gouvernement, 101.—B. Mierisch. Die Auswurfsblöcke des Monte Somma, 113.—H. Wulf. Beitrag zur Petrographie des Hererolandes in Südwest-Africa, 193.—F. Becke. Ätzversuche am Pyrit, 232.—A. Cathrein. Ueber Chloritoidschiefer von Grossarl, 331.—H. Wichmann. Brookit vom Schwarzkopf, 338.—E. Ludwig und G. Tschermak. Der Meteorit von Angra dos Reis, 341.—L. Hubbard. Beiträge zur Kenntniss der Nosean-führenden Auswürflinge des Laacher Sees, 356.—A. Cathrein. Beiträge zur Mineralogie Tirol's, 400.

———. Kaiserlich-königliche zoologisch-botanische Gesellschaft. Verhandlungen. Band xxxvi. Quartal 1-4. 1886.

O. Stapf. Die Pflanzenreste des Hallstätter Heidengebirges, 407.

Warwick. Warwickshire Naturalists' and Archæologists' Field Club. Proceedings, 1885. 1886.

P. B. Brodie. On a recent Discovery of Annulose Animals (*Blatta* and a Scorpion) in British and Foreign Upper and Middle Silurian Rocks, 18.—P. B. Brodie. On the last Boring near London, and its results, 22.

Washington. Smithsonian Institution. Annual Report for the year 1884. Parts 1 & 2. 1885.

———. Bureau of Ethnology. Fourth Annual Report, 1882-83. 4to. Washington. 1886.

Wellington, N. Z. New-Zealand Institute. Transactions and Proceedings, 1885. Vol. xviii. 1886.

S. W. Baker. A Description of the New Volcano in the Friendly Islands, near Tongatabu, 41.—T. J. Parker. Notes on a Skeleton of *Notornis*, 78.—F. W. Hutton. On the Geology of Scinde Island, 327.—F. W. Hutton. New Species of Tertiary Shells, 333.—F. W. Hutton. The Wanganui System, 336.—A. McKay. On the Age of the Napier Limestone, 367.—W. Skey. On a new Mineral (Awaruite) from Barn Bay, 401.—W. S. Hamilton. On Platinum Crystals in the Ironsands of Orepuki Goldfields, 402.

———. ———. ———. Index, Vols. i.—xvii. 1886.

Wiesbaden. Nassauische Vereins für Naturkunde. Jahrbücher. Jahrgang xxxix. 1886.

R. Fresenius. Neue chemische Untersuchung des Kochbrunnens zu Wiesbaden, 1.—H. Fresenius. Chemische Untersuchung der Schützenhof-Quelle zu Wiesbaden, 21.—F. Kinkelin. Zur Geologie der unteren Wetterau und des unteren Mainthales, 55.

Winchester. Natural History Society. Geological Section. Geological Notes. 1886. (12mo.) Presented by E. Westlake, Esq., F.G.S.

York. Yorkshire Philosophical Society. Annual Report for 1886. 1887.

H. M. Platnauer. On the Occurrence of *Strophodus Rigaudi* (Sauv.) in the Yorkshire Cornbrash, 36.

Zoological Society. Proceedings, 1886. Parts 1–4. 1887.

A. Smith Woodward. On the Anatomy and Systematic Position of the Liassic Selachian, *Squaloraja polyspondyla*, Agassiz, 527.—A. S. Woodward. On the Relations of the Mandibular and Hyoid Arches in a Cretaceous Shark (*Hybodus dubrisiensis*, Mackie), 218.

———. Transactions. Vol. xii. Parts 3–6. 1886–87.

E. T. Newton. On the Remains of a Gigantic Species of Bird (*Gastornis Klaassenii*, n. sp.) from the Lower Eocene Beds near Croydon, 143.—J. von Haast. On *Megalopteryx Hectori*, a new Gigantic Species of Apterygian Bird, 161.—J. von Haast. On *Dinornis Oweni*, a new Species of Dinornithidæ, with some remarks on *D. curtus*, 171.

———. Report of the Council for the Year 1886. 1887.

2. BOOKS.

Names of Donors in Italics.

Abel, Sir Frederick. The Work of the Imperial Institute. 8vo. London, 1887.

Adamson, S. A., and A. Harker. Bibliography of the Geology and Palæontology of the North of England, 1885. 8vo. 1886.

———. The Hitchingstone, Keighley Moor. 8vo. Birmingham, 1886.

- Albrecht, P.* Anatomische Schriften des Professors Dr. P. Albrecht. 8vo. Hamburg, 1886.
- . Mittheilungen zur 59 Versammlung deutscher Naturforscher und Ärzte zu Berlin. Aus der Sektion für Anatomie. 8vo. 1886.
- . Ueber den morphologischen Werth überzähliger Finger und Zehen. 8vo. 1886.
- . Ueber die cetoide Natur der Promammalia. 8vo. Jena, 1886.
- . Ueber die morphologische Bedeutung der Penischisis, Epi- und Hypospadie des Menschen. 8vo. 1886.
- . Ueber eine in zwei Zipfel auslaufende rechtsseitige Vorderfloss bei einem Exemplare von *Protopterus annectens*, Ow. 8vo. Berlin, 1886.
- . Verläuft der Nervenstrom in nicht geschlossener, oder geschlossener Strombahn, und wie gelangt er, wenn letzteres der Fall ist, zum Sitze der elektromotorischen Kraft zurück? 8vo. Erlangen, 1887.
- . Zur Diskussion der die Hasenscharten und schrägen Gesichtspalten betreffenden Vorträge der Herren Bisudi und Morian. 8vo. 1886.
- Alsace-Lorraine. Geologische Specialkarte von Elsass Lothringen. Abhandlungen. Band iv. Heft 3. 8vo. Strassburg, 1887. *Purchased.*
- Argentine Republic. Informe oficial de la Comision Cientifica agregada al Estado Mayor General de la Expedicion al Rio Negro (Patagonia) Realizada en los meses de Abril, Mayo y Junio de 1879, bajo las órdenes del General D. Julio A. Roca. Entrega I. Zoología. 4to. Buenos Aires, 1881. *Presented by the Académie Nationale des Sciences résidant a Cordoba.*
- . ———. Entrega II. Botánica. 4to. Buenos Aires, 1881.
- . ———. Entrega III. Geología. 4to. Buenos Aires, 1882.
- . Censo General de la Provincia de Buenos Aires; Demográfico, Agrícola, Industrial, Comercial, &c., verificado el 9 de Octubre de 1881 bajo la administracion del Doctor Don Dardo Rocha. 4to. Buenos Aires, 1883.
- . Sistema di Medidas y Pesas de la República Argentina. 8vo. Buenos Aires, 1881.
- . Ferro-carril Central del Norte. Ramal á la Rioja y Catamarca. Seccion Primera. De la estacion recreo (F.C.C.N.) Chumbicha. Informe General del proyecto con las especificaciones, analisis de precios y documentos justificativos presentado al Ministerio del Interior por el Departamento de Ingenieros civiles de la Nacion. 8vo. Buenos Aires, 1883.

- Army Medical Department.* Report for the year 1884. Vol. xxvi. 8vo. London, 1886.
- Atkinson, E. T.* Annual Address to the Asiatic Society, Calcutta, February 2, 1887. 8vo. Calcutta, 1887.
- Atkinson, W. C.* A Historical and Statistical Account of New Brunswick, B.N.A., with advice to Emigrants. 3rd edition. 8vo. Edinburgh, 1844. *Presented by W. Whitaker, Esq., F.G.S.*
- Bagot, A.* Accidents in Mines; their Causes and Prevention. 8vo. London, 1878. *Presented by W. S. Dallas, Esq., F.L.S.*
- Bargagli, P.* Un nuovo lavoro del Socio sig. Herbert Goss "Di alcuni insetti scoperti recentemente in rocce carbonifere e siluriane." 8vo. Florence, 1886.
- Barrois, C.* Observations sur la constitution géologique de la Bretagne. (2^e article.) 8vo. Lille, 1884.
- . Note préliminaire sur les schistes à staurotide du Finistère. 8vo. Lille, 1884.
- . Sur la Faune de Hout-de-Ver (Haute-Garonne). 8vo. Lille, 1886.
- . Note sur la structure stratigraphique des Montagnes du Menez (Côtes-du-Nord). 8vo. Lille, 1885.
- . Sur les Tremblements de Terre de l'Andalousie. 8vo. Lille, 1885.
- . Mémoire sur le calcaire à polypiers des Cabrières (Hérault). 8vo. Lille, 1886.
- . Note sur le Kerzanton de la Rade de Brest. 8vo. Lille, 1887.
- Bayonne Bar.* Instruction pour aller chercher la Barre de Bayonne, entrer dans la rivière ou mouiller dans les environs, par Bougret de la Grye. 8vo. Paris, 1886. *Presented by the Dépot de la Marine.*
- Beinert, C. C.* Der Meteorit von Braunau am 14 Juli 1847. 8vo. Breslau, 1847. *Presented by the Royal Society.*
- Bell, H. G.* Selections of the most remarkable Phenomena of Nature. 12mo. Edinburgh, 1887. *Presented by W. Whitaker, Esq., F.G.S.*
- Bonney, T. G.* Address to the Mineralogical Section of the British Association, 1886. 8vo. London, 1886.
- . Address to the Mineralogical Society, 1885. 8vo. London, 1886.
- . On a Glaucothane-Eclogite from the Val d'Aoste. 8vo. London, 1886.
- Boulger, G. S.* On the Connection in Time of Changes in Fossil Floras with those of Faunas. 8vo. London, 1887.

- British Museum (Natural History). A Guide to the Exhibition Galleries of the Department of Geology and Palæontology. 4th edition. 8vo. London, 1886. *Presented by the Trustees.*
- . ———. ———. ———. *Presented by Dr. H. Woodward, F.R.S., V.P.G.S.*
- . Catalogue of the Blastoidea in the Geological Department, by R. Etheridge, jun., and P. H. Carpenter. 4to. London, 1886. *Presented by the Trustees.*
- . Catalogue of the Fossil Mammalia. Part IV., containing the Order Ungulata, Suborder Proboscidea. By R. Lydekker. 8vo. London, 1886. *Presented by the Trustees.*
- Brodie, P. B.* On a recent Discovery of Annulose Animals (*Blatta* and a Scorpion) in British and Foreign Upper and Middle Silurian Rocks. 8vo. Warwick, 1886.
- . On the last Boring near London and its Results. 8vo. Warwick, 1886.
- Brough, B. H.* Use of the Magnetic Needle in exploring for Iron-Ore. 8vo. London, 1887.
- Brown, J. A.* Sketch of the Geology of Ealing, with Evidences of Glacial Deposit. 8vo. London, 1884. *Presented by W. Whitaker, Esq., F.G.S.*
- Brückner, E.* Die Vergletscherung des Salzachgebietes nebst Beobachtungen über die Eiszeit in der Schweiz. 8vo. Vienna, 1886. *Purchased.*
- Buckler, W.* See *Ray Society.*
- Buda-Pest. Allgemeine Landes-Ausstellung, 1885. Special-Katalog der Viten Gruppe für Bergbau, Hüttenwesen und Geologie. 8vo. Budapest, 1885. *Presented by the Fachcommission der Viten Gruppe through the Hungarian Geological Institute.*
- Californian State Mining Bureau.* Sixth Annual Report. Parts 1 & 2, for the year 1886. 8vo. Sacramento, 1886-87.
- Callon, J.* Lectures on Mining, delivered at the School of Mines, Paris. Translated at the Author's request, by C. Le Neve Foster and W. Galloway. Vol. iii. 8vo. London, 1886. *Purchased.*
- Canada. Colonial and Indian Exhibition, London, 1886. Descriptive Catalogue of a Collection of Economic Minerals of Canada, by the Geological Corps, *A. R. C. Selwyn*, Director. 8vo. London, 1886.
- . *Geological and Natural-History Survey.* Report. New Series, Vol. i. 1885. 8vo. Montreal, 1886.
- Cape of Good Hope. Report on a supposed extensive deposit of Coal underlying the Central Districts of the Colony, by *E. J. Dunn.* 4to. Cape Town, 1886. *Presented by the Secretary of State for the Colonies.*

- Caruana, A. A.* Recent further Excavations of the Megalithic Antiquities of "Hagiar-Kim," Malta, executed in the year 1885. Obl. fol. Malta, 1886.
- Carthaus, E.* Mittheilungen über die Triasformation im nordöstlichen Westfalen und in einigen angränzenden Gebieten. 8vo. Würzburg, 1886. *Purchased.*
- Caspary, R.* Einige neue Pflanzenreste aus dem samländischen Bernstein. 4to. Königsberg in Pr., 1886.
- Castillo, A. del, y M. Bárcena.* El Hombre del Peñon. 8vo. Mexico, 1885.
- Challenger.* Reports on the Scientific Results of the Voyage of H.M.S. 'Challenger' during the years 1873-76. Botany. Vol. ii. 4to. London, 1886. *Presented by H.M. Treasury.*
- . ———. Zoology. Vol. xv. 4to. London, 1886. *Presented by H.M. Treasury.*
- . ———. ———. Vol. xvi. 4to. London, 1886. *Presented by H.M. Treasury.*
- . ———. ———. Vol. xvii. 4to. London, 1886. *Presented by H.M. Treasury.*
- . ———. ———. Vol. xviii. Parts 1 & 2, and plates. 4to. London, 1887. *Presented by H.M. Treasury.*
- . ———. ———. Vol. xix. 4to. London, 1887. *Presented by H.M. Treasury.*
- Chaper, —.* Note sur une Pegmatite diamantifère de l'Hindoustan. 8vo. Paris, 1886.
- Chaubard, L. A.* Eléments de Géologie mis à la portée de tout le monde. 2^e édition. 8vo. Paris, 1838. *Presented by H. Bauerman, Esq., F.G.S.*
- Chevreul, Centenaire de M.,* 31 Août, 1886. Discours prononcés au Muséum d'Histoire Naturelle. 4to. Paris, 1886.
- Cialdi, A.* Sul moto ondoso del mare e su le correnti di esso. 2^e édition. 8vo. London, 1866. *Presented by the Royal Society.*
- Claypole, E. W.* Buffalo and Chicago, or "What might have been." 8vo. Salem, 1886.
- Close, M. H.* The Geology of the Neighbourhood of Dublin, as affecting its Sanitary Conditions. 8vo. London, 1884. *Presented by W. Whitaker, Esq., F.G.S.*
- Cocco, L.* Risposta alle osservazioni di Luigi F. Schopen fatte circa le opinioni del Prof. Sequenza sul Lias superiore dei dintorni di Taormina, 1886. 8vo. Messina, 1886.

- Cockburn, W. A Letter to Professor Buckland concerning the Origin of the World. 8vo. London, 1838. *Purchased.*
- . A new System of Geology; dedicated to Professor Sedgwick. 8vo. London, 1849. *Purchased.*
- Cole, E. M. Notes on the Geology of the Hull, Barnsley, and West Riding Junction Railway and Dock. 8vo. Hull, 1886. *Presented by G. Bohn, Esq.*
- Conwentz, H. Ueber ein tertiäres Vorkommen cypressenartiger Hölzer bei Calistoga in Californien. 8vo. Stuttgart, 1878.
- . Bericht über die Durchforschung der Provinz Westpreussen in naturhistorischer, archäologischer und ethnologischer Beziehung Seitens des Westpreussischen Provinzial-Museums und der vom Provinzial-Landtage subventionirten Vereine während der ersten sechsjährigen Etatsperiode der Verwaltung des Westpreussischen Provinzial-Verbandes. 8vo. Danzig, 1884.
- . Heinrich Robert Göppert, sein Leben und Wirken. 8vo. Danzig, 1815.
- . Sobre Algunos árboles fósiles del Rio Negro. 8vo. Buenos Aires, 1885.
- . Herstellung mikroskopischer Präparate von fossilen Pflanzen. 8vo. Danzig?, 18—.
- . See Göppert, H. R.
- Cope, E. D. The Vertebrata of the Swift Current Creek Region of the Cypress Hills. 8vo. Montreal, 1885.
- . On two new Species of Three-toed Horses from the Upper Miocene, with Notes on the Fauna of the *Ticholeptus*-beds. 8vo. Salem, 1886.
- . Schlosser on *Creodonta* and *Phenacodus*. 8vo. Salem, 1886.
- . Schlosser on the Phylogeny of the Ungulate Mammalia. 8vo. Salem, 1886.
- . Systematic Catalogue of Species of Vertebrata found in the Beds of the Permian Epoch in North America, with Notes and descriptions. 4to. Philadelphia, 1886.
- . The Phylogeny of the Camelidæ. 8vo. Salem, 1886.
- Cotta, B. von. Geologische Bilder. 6^e Auflage. 8vo. Leipzig, 1876. *Purchased.*
- Cotteau, G. Paléontologie Française. 1^e Série. Animaux Invertébrés. Terrains Tertiaires. Éocène, Echinides. Tome i. Feuilles 1–11. 8vo. Paris, 1885–86.
- . Echinides nouveaux ou peu connus. (4^e article.) 8vo. Paris, 1885.
- . Sur les Echinides des calcaires de Stramberg. 4to. Paris, 1884.

- Cotteau, G.* Considérations générales sur les Echinides du terrain jurassique de la France. 4to. Paris, 1885.
- . Sur les Echinides éocènes de la famille des Spatangidées. 4to. Paris, 1886.
- . La paléontologie en 1885. 8vo. Paris, 1885.
- . La Géologie au Congrès Scientifique de Grenoble in 1885 et Compte-rendu du Congrès. 8vo. Auxerre, 1886.
- , Péron et Gauthier. Echinides fossiles de l'Algérie. Fasc. 9. Etage Eocène. 8vo. Paris, 1885.
- Crane, Agnes.* On a Brachiopod of the Genus *Atretia*, named in MS. by the late Dr. T. Davidson. 8vo. London, 1886.
- Credner, H.* Die Stegocephalen aus dem Rothliegenden das Plauen'schen Grundes bei Dresden. 8vo. Berlin, 1886.
- . Elemente der Geologie. 6^e Auflage. 8vo. Leipzig, 1887.
- Crosskey, H. W.* Note on the Glacial Geology of the district around Loch Sween, Argyllshire. 8vo. Birmingham, 1886.
- Cuvier, F.* De l'Histoire Naturelle des Cétacés ou recueil et examen des faits dont se compose l'histoire naturelle de ces animaux. 8vo. Paris, 1836. *Presented by the Royal Society.*
- Dagincourt, —.* Annuaire Géologique Universel. Tome ii. 8vo. Paris, 1886.
- Dallas, James.* Professor John Morris, M.A., F.G.S. Slip. Exeter, 1886.
- Dana, J. D.* A dissected Volcanic Mountain; some of its revelations. 8vo. New Haven, 1886.
- . Berkshire Geology (U.S.A.). 8vo. Pittsfield, Mass., 1886.
- . On some general terms applied to Metamorphism, and to the Porphyritic Structure of Rocks. 8vo. New Haven, 1886.
- . On Volcanic Eruptions of Barren Island, Vesuvius, and Kilauea. 8vo. New Haven, 1886.
- . Volcanic Action. 8vo. New Haven, 1887. (See Emerson, J. S., &c., on Kilauea).
- Dawson, G. M.* Note on the Occurrence of Jade in British Columbia, and its Employment by the Natives. 8vo. Montreal, 1887.
- . Notes to accompany a Geological Map of the northern portion of the Dominion of Canada, east of the Rocky Mountains. 8vo. Montreal, 1887.
- . On certain Borings in Manitoba and the North-west Territory. 4to. Montreal, 1887.
- . On the Canadian Rocky Mountains, with special reference to that part of the Range between the forty-ninth Parallel and the Head-waters of the Red Deer River. 8vo. Montreal, 1886.

- Dawson, Sir J. W.* Address to the British Association for the Advancement of Science, 1886. 8vo. London, 1886.
- . On Rhizocarps in the Erian (Devonian) Period in America. 8vo. Chicago, 1886.
- . On the Fossil Plants of the Laramie Formation of Canada. 4to. Montreal, 1886.
- Dewalque, G.* Discours prononcé au nom de l'Académie Royale de Belgique lors des Funérailles de M. F. L. Cornet. 8vo. Brussels, 1886.
- Dick, W. H.* The famous Mount Morgan Gold Mine, Rockhampton, Queensland, its History, Geological Formation, and Prospects. 8vo. Rockhampton, 1887.
- Diller, J. S.* Notes on the Geology of Northern California. 8vo. Washington, 1886.
- . The latest Volcanic Eruption in Northern California and its peculiar Lava. 8vo. New Haven, 1887.
- Dowker, G., J. Reid, and J. Marten.* Observations on Romney Marsh and Lydd Beach, with an account of a Botanical Ramble from Appledore to Lydd and Dungeness Point. 8vo. Canterbury, 1868.
- Dressel, L.* Die Basaltbildung in ihren einzelnen umständen Erläutert. 4to. Haarlem, 1866. *Purchased.*
- Duncan, P. M.* On the *Astrocoenice* of the Sutton Stone and other Deposits of the Infra-Lias of South Wales. 8vo. London, 1886.
- . On the Structure and Classificatory Position of some Madreporaria from the Secondary Strata of England and South Wales. 8vo. London, 1886.
- Dupont, E.* Sur le Famennien de la Plaine des Fagnes. 8vo. Brussels, 1886.
- Eley, H.* Geology in the Garden; or the Fossils in the Flint Pebbles. 8vo. London, 1859. *Purchased.*
- Emerson, J. S., L. L. Van Slyke, and F. S. Dodge.* Kilauea after the eruption of March, 1886. 8vo. New Haven, 1887. *Presented by Prof. J. D. Dana, F.M.G.S.*
- Encyclopædia Britannica.* 9th edition. Vol. xxi. Rot-Sia. 4to. Edinburgh, 1886. *Purchased.*
- . ———. Vol. xxii. Sib-Szo. 4to. Edinburgh, 1887. *Purchased.*
- Encyclopædic Dictionary.* Vol. v. Pt. 2. Parc-Quod. 4to. London, 1886. *Presented by the Rev. R. Hunter, F.G.S.*

- Encyclopædic Dictionary. Vol. vi. pt. 1. Quoi-Shipp. 4to. London, 1887. *Presented by the Rev. R. Hunter, F.G.S.*
- England and Wales. *Geological Survey*. Memoirs. Vol. iv. The Geology of the London Basin. By W. Whitaker. 8vo. London, 1872. *Purchased.*
- Ettingshausen, C. von.* Die fossile Flora von Sagor in Krain. Theil III. und Schluss. 4to. Vienna, 1885.
- . Beiträge zur Kenntniss der Tertiärflora Australiens. Zweite Folge. 4to. Vienna, 1886.
- Falsan, A. Notice sur la géologie et la minéralogie du Canton d'Hyères (Var). 8vo. Lyons, 1863. *Purchased.*
- Favre, E.* Revue Géologique Suisse pour l'année 1885. xvi. 8vo. Geneva, 1886.
- Finistère. List of works on the Geology of. 4to. 1886. *Presented by Prof. T. G. Bonney, D.Sc., F.R.S., F.G.S.*
- Fisher, O.* On the Variations of Gravity at certain Stations of the Indian Arc of the Meridian in Relation to their Bearing upon the Constitution of the Earth's Crust. 8vo. London, 1886.
- . An Attempt to explain certain Geological Phenomena by the application to a Liquid Substratum of Henry's Law of the Absorption of Gases. 8vo. Cambridge, 1887.
- . On the Amount of the Elevations attributable to Compression through the Contraction during Cooling of a Solid Earth. 8vo. London, 1887.
- Fleming, J. The Lithology of Edinburgh. Edited with a memoir by the Rev. John Duns. 8vo. Edinburgh, 1859. *Purchased.*
- Frazer, P.* General Notes on the Geology of York County, Pennsylvania. 8vo. Philadelphia, 1886.
- Freiesleben, J. C. Magazin für die Oryktographie von Sachsen. Hefte 1-9. 8vo. Freyberg, 1828-36. *Purchased.*
- Frič, A. Führer durch die geologischen Sammlungen im Museum des Königreiches Böhmen in Prag. 8vo. Prag, 1881. *Purchased.*
- Friedländer, R., und Sohn.* Bibliotheca historico-naturalis et Mathematica. Lager-Catalog. 8vo. Berlin, 1886.
- Gaudry, A.* La Grotte de Montgaudier. 4to. Paris, 1886.
- . Le petit *Ursus spelæus* de Gargas. 4to. Paris, 1887.
- . Sur un bois de Renne, orné de gravures, que M. Eugène Paignon a découvert à Montgaudier. 4to. Paris, 1886.
- . Sur un nouveau genre de Reptile trouvé dans le Permien d'Autun. 8vo. Paris, 1886.
- Geinitz, H. B.* Zur Dyas in Hessen. 8vo. Cassel, 1886.

- Gemmellaro, G. G. Sopra alcune faune Giuresi e Liasiche della Sicilia. Text and plates. 4to. Palermo, 1872-82. *Purchased.*
- Geyler, T., und F. Kinkelin. Oberpliocän-Flora aus den Baugruben des Klarbeckens bei Neiderrad und der Schleuse bei Höchst a. M. 4to. Frankfurt-a.-M., 1887. *Presented by W. H. Lindley, Esq., M.Inst.C.E., F.G.S.*
- Gillieron, V. La faune des couches à *Mytilus* considérée comme phase méconnue de la transformation de formes animales. 8vo. Basel, 1887.
- Goldschmidt, V. Index der Krystallformen der Mineralien. Lief. 1 & 2. 8vo. Berlin, 1886. *Purchased.*
- Goodchild, J. G. Observations upon the Stratigraphical Relations of the Skiddaw Slates. 8vo. London, 1886.
- Göppert, H. R., und A. Menge. Die Flora des Bernsteins und ihre Beziehungen zur Flora der Tertiarformation und der Gegenwart. Band 2, von H. Conwentz. 4to. Danzig, 1886.
- Gottsche, C. Geologische Skizze von Korea. 8vo. Berlin, 1886.
- Great Britain and Ireland. Mines and Minerals. Mining and Mineral Statistics of the United Kingdom of Great Britain and Ireland, including List of Mines and Mineral Works for the year 1885. Prepared by H.M. Inspectors of Mines. 4to. London, 1886. *Presented by the Secretary of State for the Home Department.*
- Gresley, W. S. A Fossil Tree at Clayton, Yorkshire. 8vo. Birmingham, 1886.
- Griffiths, G. S. Evidences of a Glacial Epoch from Kerguelen's Land, being comments upon the 'Challenger' Reports. 8vo. Melbourne, 1886.
- . On the recent Earth-tremors and the conditions which they indicate. 8vo. Melbourne, 1885.
- Groth, P. Repertorium der mineralogischen und krystallographischen Literatur vom ende d. J. 1876 bis anfang d. J. 1885, und Generalregister der Zeitschrift für Krystallographie und Mineralogie, Bände i.-x. 8vo. Leipzig, 1886. *Purchased.*
- Gümbel, C. W. von. Ueber die Natur und Bildungsweise des Glaukonits. 8vo. Munich, 1886.
- . Geologie von Bayern. 1 Theil. Grundzüge der Geologie. Lief. 3 & 4. 8vo. Cassel, 1886 & 1887. *Purchased.*
- Haas, H. J. Die Leitfossilien. 8vo. Leipzig, 1887. *Purchased.*
- Harker, A. On a remarkable Exposure of the Kellaway's Rock in a recent cutting near Cirencester. 8vo. Gloucester, 1887.

- Haviland, A.* On the Study of the Glacial Period in the Isle of Man. 8vo. Douglas, 1886.
- Hazell's Annual Cyclopædia, 1887. Edited by *E. D. Price, F.G.S.* 8vo. London, 1887.
- Hébert, E.* Observations sur les groupes sédimentaires les plus anciens du nord-ouest de la France. 4to. Paris, 1886.
- Heim, A., and A. Penck.* On the District of the Ancient Glaciers of the Isar and of the Linth. 8vo. London, 1886. *Presented by Dr. Hinde.*
- Hemiup, Maria R.* Law of Heat. 8vo. Geneva, N. Y. 1886.
- Hennessy, H.* On the Physical Structure of the Earth. 8vo. London, 1886.
- . Note on the Annual Precession calculated on the Hypothesis of the Earth's Solidity. 8vo. London, 1886.
- . On the Fluid State of Bodies composing our Planetary System. 8vo. Dublin, 1886.
- Hermite, H.* Études géologiques sur les Iles Baléares. 8vo. Paris, 1879. *Purchased.*
- Hertwig, R.* Gedächtnissrede auf Carl Theodor v. Siebold. 4to. Munich, 1886. *Presented by the Academy of Sciences of Munich.*
- Hesse.* Grossherzoglich hessische geologische Landesanstalt. Geologische Karte $\frac{1}{250000}$. Erläuterungen. Lief. 1. Blatt Messel. 8vo. Darmstadt, 1886.
- . ———. ———. Lief. 1. Blatt Rossdorf. 8vo. Darmstadt. 1886. *Presented by the Survey.*
- Hinde, G. J.* On Beds of Sponge-remains in the Lower and Upper Greensand of the South of England. 4to. London, 1886.
- . On the Genus *Hindia*, Duncan, and the Name of its Typical Species. 8vo. London, 1887.
- Hitchcock, C. H.* The Geological Map of the United States. 8vo. Easton, 1886. (See MAPS.)
- Hörnes, R.* Manuel de Paléontologie. Traduit de l'Allemand par L. Dollo. Fasc. 4 & 5. 8vo. Paris, 1886. *Purchased.*
- Howitt, A. W.* The Sedimentary, Metamorphic, and Igneous Rocks of Ensay. 8vo. Melbourne, 1886.
- Hubbard, L. L.* Beiträge zur Kenntniss der Nosean-führenden Auswürflinge des Laacher Sees. 8vo. Vienna, 1887.
- Hughes, T. M'Kenny.* The Sedgwick Memorial Geological Museum. 8vo. Cambridge, 1886.

- Hunt, T. S.* Mineral Physiology and Physiography. A second series of chemical and geological essays with a general introduction. 8vo. Boston, 1886.
- Hutton, F. W.* On the Geology of Scinde Island. 8vo. Wellington?, 1886.
- . On the Geology of the New-Zealand Alps. 8vo. Hobart, 1886.
- . The Mollusca of the Pareora and Oamaru Systems of New Zealand. 8vo. Sydney, 1886.
- India. *Geological Survey*. Palæontologia Indica. Ser. vii. & xiv. Titlepage and Contents of vol. i. of Tertiary and Upper Cretaceous Fauna of Western India. 1886.
- . ———. ———. Ser. x. Indian Tertiary and Post-Tertiary Vertebrata. Vol. iv. Part 1. Siwalik Mammalia. Supplement i. By R. Lydekker. 4to. Calcutta, 1886.
- . ———. ———. ———. Indian Tertiary and Post-Tertiary Vertebrata. Vol. iv. Part 2. By R. Lydekker. 4to. Calcutta, 1886.
- . ———. ———. Ser. xii. The Fossil Flora of the Gondwána System. Vol. iv. Part 2. The Fossil Flora of some of the Coal Fields in Western Bengal. By O. Feistmantel. 4to. Calcutta, 1886.
- . ———. ———. Ser. xiii. Salt-Range Fossils. By W. Waagen. I. Productus-limestone Fossils; VI. Coelenterata. 4to. Calcutta, 1886.
- . ———. ———. Ser. xiv. Tertiary and Upper Cretaceous Fossils of Western Sind. Vol. I. Part 3. The Fossil Echinoidea. Fasc. vi. By P. Martin Duncan and W. P. Sladen. 4to. Calcutta, 1886.
- . ———. Records. Vol. xix. Parts 3 & 4. 8vo. Calcutta, 1886.
- . ———. ———. Vol. xx. Parts 1 & 2. 8vo. Calcutta, 1887.
- . *Indian Museum*. Catalogue of the Remains of Siwalik Vertebrata contained in the Geological Department. Parts 1 & 2. By R. Lydekker. 8vo. Calcutta, 1885 & 1886.
- . ———. Catalogue of the Remains of Pleistocene and Pre-historic Vertebrata contained in the Geological Department. By R. Lydekker. 8vo. Calcutta, 1886.
- International Polar Expeditions, 1882–83. Fort Rae. Observations [Meteorological &c.] 4to. London, 1886. *Presented by the Meteorological Office.*
- Irving, R. D.* Origin of the Ferruginous Schists and Iron Ores of the Lake Superior Region. 8vo. New Haven, 1886.

Jack, R. L. See Queensland.

Johnston-Lavis, H. J. The Relationship of the Structure of Rocks to the Conditions of their Formation. 8vo. Dublin, 1886.

Jones, T. Rupert. On Carboniferous Ostracoda from the Gayton Boring, Northamptonshire. 8vo. Northampton, 1886.

———. On Coal Deposits of South Africa. Slips. London, 1886.

———. On Palæozoic Phyllopora. 8vo. London, 1886.

———. Review. "The Volcanoes of Japan, by John Milne." Slip. London, 1886.

———. The Geology and Mineral Products of South Africa. Slip. London, 1886.

———. History of Sarsens. 8vo. Devizes, 1887.

———. Note on *Nummulites elegans*, Sowerby, and other English Nummulites. 8vo. London, 1887.

———. Notes on the Palæozoic Bivalved Entomostraca.—Nos. 23 & 24. On some Silurian Genera and Species. 8vo. London, 1887.

———. The Mineral Wealth of South Africa. 8vo. London, 1887.

———, and *J. W. Kirkby.* A List of the Genera and Species of Bivalved Entomostraca found in the Carboniferous Formations of Great Britain and Ireland, with Notes on the Genera and their Distribution. 8vo. London, 1886.

———, ———. Notes on the Distribution of the Ostracoda of the Carboniferous Formations of the British Isles. 8vo. London, 1886.

———, ———. Notes on the Palæozoic Bivalved Entomostraca.—No. 22. On some undescribed Species of British Carboniferous Ostracoda. 8vo. London, 1886.

———, ———. On some Fringed and other Ostracoda from the Carboniferous Series. 8vo. London, 1886.

Karsten, H. Géologie de l'ancienne Colombie Bolivarienne, Vénézuëla, Nouvelle-Grenade et Ecuador. 4to. Berlin, 1886. *Purchased.*

Kenngott, A., A. von Lasaulx, and F. Rolle. Handwörterbuch der Mineralogie, Geologie und Palæontologie. 3 vols. 8vo. Breslau, 1883, 1885, & 1887. *Purchased.*

Klein, S. T. Thirty-six Hours' Hunting among the Lepidoptera and Hymenoptera of Middlesex, with Notes on the Method adopted for their Capture. 8vo. Bath, 1887.

- Klement, C.* Notice sur la composition chimique de la météorite de Saint-Denis-Westrem (Flandre Orientale). 8vo. Brussels, 1886.
- Kokscharow, N. v.* Materialien zur Mineralogie Russlands. Band ix. pp. 273-368. 8vo. St. Petersburg, 1886.
- Könen, A. von.* Ueber neue Cystideen aus den Caradoc-Schichten der Gegend von Montpellier. 8vo. Stuttgart, 1886.
- Koninck, L. G. de, et M. Lohest.* Notice sur le parallélisme entre le calcaire carbonifère du nord-ouest de l'Angleterre et celui de la Belgique. 8vo. Brussels, 1886.
- Kowalevski, A.* Observations sur le développement des Brachiopodes. Analyse par *D. Ehlert* et *Deniker*. 8vo. Paris, 1883.
- Lapparent, A. de.* Abrégé de Géologie. 8vo. Paris, 1886.
- . ———. ———. ———. Presented by *Clement Reid, Esq., F.G.S.*
- . Traité de Géologie. 2^e édition. 8vo. Paris, 1885.
- . Conférence sur le sens des mouvements de l'écorce terrestre. 8vo. Paris, 1887.
- Lawrence, E.* The Progress of a Century ; or the Age of Iron and Steam. 8vo. London, 1886.
- Lindley, W. H.* Photographs of Upper Pliocene Flora found in Excavations made near Frankfort-on-Main. 1887.
- Liversidge, A.* Presidential Address to the Royal Society of New South Wales. 8vo. Sydney, 1886.
- Lucas, C.* An Essay on Waters. Part 1. 8vo. London, 1756. Purchased.
- Lütken, C.* Antikritiske Bemærkninger i Anledning af Kæmpe-Dovendyr-Slægten *Cœlodon*. 8vo. Copenhagen, 1886.
- Lydekker, R.* Description of three Species of *Scelidotherium*. 8vo. London, 1886.
- . The Fossil Vertebrata of India. 8vo. Calcutta, 1887.
- Malet, H. P.* Incidents in the Biography of Dust. 8vo. London, 1887. Presented by *W. S. Dallas, Esq., F.L.S.*
- Marcou, J. B.* A List of the Mesozoic and Cenozoic Types in the collections of the U. S. Museum. 8vo. Washington, 1885 ; and Supplement, 1886.
- . Bibliographies of American Naturalists. III. Publications relating to Fossil Invertebrates. 8vo. Washington, 1885.
- Marsh, O. C.* American Jurassic Mammals. 8vo. New Haven, 1887.

- Mediterranean. Instructions Nautiques sur les îles Ioniennes, les côtes de Grèce et de Turquie, l'Archipel, le détroit des Dardanelles, la Mer de Marmora et le Bosphore. Par A. François. 8vo. Paris, 1886. *Presented by the Dépôt de la Marine.*
- Melnikow, M. Geologische Erforschung des Verbreitungsgebietes der Phosphorite am Dajester. 8vo. St. Petersburg, 1885.
- Meneghini, G. *Goniodiscus Ferrazzii*, Mgh., nuova Stelleride terziaria del Vicentino. 8vo. Pisa, 1886.
- Miall, L. C. The Geology, Natural History, and Prehistoric Antiquities of Craven, in Yorkshire. 4to. Leeds, 1878. *Purchased.*
- Miall, L. C., and A. Denny. Studies in Comparative Anatomy. III. The Structure and Life-history of the Cockroach (*Periplaneta orientalis*). An Introduction to the Study of Insects. 8vo. London, 1886.
- Minnesota. *Geological and Natural History Survey 1872-82.* The Geology of Minnesota. Vol. i. of the Final Report. By N. H. Winchell and W. Upham. 4to. Minneapolis, 1884.
- . ———. Thirteenth Annual Report for the year 1884. 8vo. St. Paul, 1885.
- . ———. Fourteenth Annual Report for the year 1885. 8vo. St. Paul, 1886.
- Morgan, C. Lloyd. Contributions to the Geology of the Avon Basin. 8vo. Bristol, 1886.
- Morse, E. S. Ancient and Modern Methods of Arrow-Release. 8vo. Salem, 1886.
- Morton, G. H. The Carboniferous Limestone and Cefn-y-fedw Sandstone of Flintshire. 8vo. Liverpool, 1886.
- Mott, F. T. The Geological History of Charnwood Forest. 8vo. London, 1885.
- Nathorst, A. G. Nouvelles observations sur des traces d'animaux et autres phénomènes d'origine purement mécanique décrits comme "Algues Fossiles." 4to. Stockholm, 1886.
- . Om de sandslipode stenarnes förekomst i de kambriska lagren vid Lugnäs. 8vo. Stockholm, 1886.
- . Om lemningar af *Dryas octopetala*, L., i kalktuff vid Rangil-torp nära Vadstena. 8vo. Stockholm, 1886.
- . Anmärkningar med anledning af A. Hellands uppsats: "Svenske geologer om indsjöerne." 8vo. Stockholm, 1887.
- . Till frågan om de skånska dislokationernas ålder. 8vo. Stockholm, 1887.

- Naumann, E. Die Erscheinungen des Erdmagnetismus in ihrer Abhängigkeit vom Bau der Erdrinde. 8vo. Stuttgart, 1887. *Purchased.*
- Neumayr, M. Erdgeschichte. Band i. Allgemeine Geologie. 8vo. Leipzig, 1887. *Purchased.*
- New Caledonia. Instructions Nautiques sur la Nouvelle-Calédonie et ses dépendances par Chambeyron et Banaré. 3^e édition. 8vo. Paris, 1886. *Presented by the Dépôt de la Marine.*
- New Hebrides. Instructions Nautiques sur les Nouvelles-Hébrides, les Iles Banks, Torrès, et l'Archipel de Santa-Cruz. 8vo. Paris, 1886. *Presented by the Dépôt de la Marine.*
- New Jersey. *Geological Survey*. Brachiopoda and Lamellibranchiata of the Raritan Clays and Greensand Marls of New Jersey, by R. P. Whitfield. 4to. Trenton, N. J., 1886.
- New South Wales. Australian Museum. Catalogue of the Echinodermata in the Australian Museum, by E. P. Ramsay. Part 1. 8vo. Sydney, 1885. *Presented by the Trustees.*
- . ———. Report of *the Trustees* for 1885. 4to. Sydney, 1886.
- . ———. Descriptive Catalogue (with Notes) of the General Collection of Minerals in the Australian Museum, by A. F. Ratte. 8vo. Sydney, 1885. *Presented by the Trustees.*
- . *Department of Mines*. Annual Report for the year 1885. 4to. Sydney, 1886.
- Newton, A., and J. W. Clark. The Woodwardian Professor and the Sedgwick Memorial Museum. 8vo. Cambridge, 1887.
- Newton, E. T. On the Remains of a Gigantic Species of Bird (*Gastornis Klaasseni*) from the Lower Eocene Beds near Croydon. 4to. London, 1886.
- . A Classification of Animals; being a Synopsis of the Animal Kingdom, with especial reference to Fossil Forms. 8vo. London, 1887.
- New York. Geological Survey. Natural History of New York. Palæontology. Vol. v. Part 1. Lamellibranchiata, II. By James Hall. Text. 4to. Albany, N. Y., 1885.
- . ———. ———. ———. Vol. v. Part 1. Lamellibranchiata, I. & II. Plates. 4to. Albany, N. Y., 1885?
- . ———. Report of the State Geologist (*James Hall*) for the year 1882. 4to. Albany, N. Y., 1883.
- . ———. Reports of the State Geologist (*James Hall*) for the years 1883–84. 8vo. Albany, N. Y., 1884–85.
- . ———. Report of the State Geologist (*James Hall*), giving an account of the condition of the work upon which he is engaged. 8vo. Albany, N. Y., 1884.

- New York State Museum of Natural History. Annual Reports 33 to 38. For 1880-1885. 8vo. Albany, 1880-1885. *Presented by James Hall, Esq., F.M.G.S., State Geologist.*
- New Zealand. Colonial Museum and Geological Survey Department. Handbook of New Zealand, by James Hector. 4th edition, revised. 8vo. Wellington, 1886. *Presented by the Agent-General for New Zealand.*
- . ———. ———. *Presented by Dr. James Hector, C.M.G., F.G.S.*
- . ———. Indian and Colonial Exhibition, London, 1886. New Zealand Court. Detailed Catalogue and Guide to the Geological Exhibits. 8vo. Wellington, 1886. *Presented by the Agent-General for New Zealand.*
- . ———. ———. ———. *Presented by Dr. James Hector, C.M.G., F.G.S.*
- . ———. Manual of the New Zealand Coleoptera, by T. Brown. Pts. 3 & 4. 8vo. Wellington, 1886.
- New Zealand Industrial Exhibition 1885, Wellington. The Official Record, 1885. 8vo. Wellington, 1886. *Presented by the New Zealand Colonial Museum.*
- New Zealand. Mines Department. Annual Reports of the Inspectors on Inspection of Mines, 1886. 4to. Wellington, 1886. *Presented by the Hon. Minister of Mines.*
- . ———. Report on the Mining Industry of New Zealand, being papers laid before Parliament during the Session of 1886. 8vo. Wellington, 1887. *Presented by the Hon. Minister of Mines.*
- . Mines Statement, by the Minister of Mines, the Hon. W. J. M. Larnach, C.M.G. 4to. Wellington, 1886. *Presented by the Hon. Minister of Mines.*
- . Preliminary Report of the Recent Volcanic Eruptions, by J. Hector, C.M.G. 4to. Wellington, 1886. *Presented by the Secretary of State for the Colonies.*
- . Preliminary Report on the Recent Volcanic Eruptions, by Dr. James Hector, C.M.G., F.G.S. 4to. Wellington, 1886.
- . Preliminary Report of the Volcanic Eruption of Tarowera 1886, by S. Percy Smith. 4to. Wellington, 1886. *Presented by the Secretary of State for the Colonies.*
- . Report on Goldfields, Classes and Schools of Mines. 4to. Wellington, 1885. *Presented by the Mines Department.*
- . Report on Goldfields, Roads, Water-races, and other works in connection with Mining. 4to. Wellington, 1886. *Presented by the Mines Department.*

- Norman, M. W. A popular Guide to the Geology of the Isle of Wight, with a Note on its relation to that of the Isle of Purbeck. 8vo. Ventnor, 1887. *Purchased.*
- Norwegian North-Atlantic Expedition. Norske Nordhavs-Expedition, 1876-78. *Presented by the Meteorologiske Institut, Christiania.*
- XV. Zoologi. Crustacea II., ved G. O. Sars. 4to. *Christiania*, 1886.
- XVI. Zoologi. Mollusca II., ved H. Friele. 4to. *Christiania*, 1886.
- XVII. Zoologi. Alcyonida, ved D. C. Danielssen. 4to. *Christiania*, 1887.
- Noury, C. Géologie de Jersey. 8vo. Paris, 1886.
- Nova Scotia. *Department of Mines.* Report for the year 1886. 8vo. Halifax, N. S., 1887.
- Æhlert, D. Sur les Fossiles dévonien du département de la Mayenne. 8vo. Paris, 1877.
- . Description de deux nouveaux genres de Crinoïdes du terrain dévonien de la Mayenne. 8vo. Paris, 1878.
- . Note sur le Calcaire de Saint-Roch, à Changé, près Laval. 8vo. Paris, 1880.
- . Crinoïdes nouveaux du dévonien de la Sarthe et de la Mayenne. 8vo. Paris, 1882.
- . Notes géologiques sur le département de la Mayenne. 8vo. Angers, 1882.
- . Note sur le calcaire de Montjean et Chalonnnes (Maine-et-Loire). 8vo. Paris, 1882.
- . Description de deux nouvelles espèces d'*Acroculia* du dévonien inférieur de la Mayenne. 8vo. Paris, 1883.
- . Note sur les Chonetes dévonien de l'Ouest de la France. 8vo. Paris, 1883.
- . Note sur *Terebratula (Centronella) Guerangeri*. 8vo. Angers, 1883.
- . Etudes sur quelques Brachiopodes dévonien. 8vo. Paris, 1884.
- . Etude sur quelques Trilobites du groupe des Proëtidæ. 8vo. Angers, 1885.
- . Description de *Goldius Gervillei*. 8vo. Paris, 1885.
- . Description de deux Centronelles du dévonien inférieur de l'ouest de la France. 8vo. Paris, 1885.

- Æhlert, D.* Etude sur quelques fossiles dévoniens de l'ouest de la France. 8vo. Paris, 1887.
- . Sur les oscillations qui se sont produites pendant la période primaire dans le bassin de Laval. 4to. Paris, 1887.
- , et — Davoust. Sur le dévonien du département de la Sarthe. 8vo. Paris, 1879.
- Omboni, G.* Di alcuni insetti fossile del Veneto. 8vo. Venice, 1886.
- Orpen, C. S.* On Matters Geological. 8vo. Bloemfontein, Orange Free State. 1886.
- Orzabal, A.* Estudio critico y comparativo de las reglas de Descartes y de Newton respecto al numero de raices de las ecuaciones numericas. 8vo. Buenos Aires, 1886.
- Paléontologie Française. Série 1. Animaux Invertébrés. Terrain Crétacé. Livr. 32. Zoophytes par de Fromentel. 8vo. Paris, 1886. *Purchased.*
- . ——. ——. Terrain Jurassique. Livr. 82. Crinoïdes, par P. De Loriol. 8vo. Paris, 1886. *Purchased.*
- . ——. ——. Terrains Tertiaires. Livr. 6-9. Eocène. Echinides. Tome i., par G. Cotteau. 8vo. Paris, 1886-87. *Purchased.*
- . Sér. 2. Végétaux. Terrain Jurassique. Livr. 36-38. Ephédrées; Spirangiées et types Proangiospermiques par G. de Saporta. 8vo. Paris, 1886. *Purchased.*
- Pennsylvania. *Geological Survey.* Annual Report for 1885, and Atlas. 8vo. Harrisburg, 1886.
- Pethö, J.* Die tertiärbildungen des Fehér-Körös-Thales zwischen dem Hegyes-Drócsa- und Pless-Kodru-Gebirge. 8vo. Budapest, 1887.
- Phillips, J. A., and H. Bauerman. Elements of Metallurgy. New edition. 8vo. London, 1887. *Presented by H. Bauerman, Esq., F.P.G.S., &c.*
- Polenus, Joannes. De motu aquæ mixto libri duo. 4to. Padua, 1717. *Presented by the Royal Society.*
- Portugal. *Commission des travaux Géologiques du Portugal.* Recueil d'études paléontologiques sur la faune crétacique du Portugal. Vol. i. Espèces nouvelles ou peu connues par Paul Choffat. Série 1. 4to. Lisbon, 1886.
- Postlethwaite, J., and J. G. Goodchild.* On some Trilobites from the Skiddaw Slates. 8vo. London, 1886.

- Prestwich, J.* On the agency of Water in Volcanic Eruptions. 8vo. London, 1886.
- . On Underground Temperatures; with observations on the conductivity of rocks; on the thermal effects of saturation and imbibition, and on a special source of heat in Mountain Ranges. 4to. London, 1886.
- Queensland. Colonial and Indian Exhibition of 1886. Handbook of Queensland Geology by *R. L. Jack*. 8vo. Brisbane, 1886.
- Quenstedt, F. A. Die Ammoniten des schwäbischen Jura. Hefte 11–15. Text 8vo. Stuttgart. Atlas, 4to. 1886 & 1887. *Purchased*.
- Quiroga, F.* Apuntes de un viaje por el Sáhara occidental. 8vo. Madrid, 1886.
- Rauff, H.* Ueber die Gattung *Hindia* Dunc. 8vo. Bonn, 1886.
- Ray Society.* The Larvæ of the British Butterflies and Moths, by the late William Buckler. Edited by H. T. Stainton. Vol. ii. 8vo. London, 1887.
- Reade, T. M.* The Origin of Mountain Ranges, considered experimentally, structurally, dynamically, and in relation to their geological history. 8vo. London, 1886.
- Reid, C.* Norfolk Amber. 8vo. Norwich, 1886.
- . On the Flora of the Cromer Forest-bed. 8vo. Norwich, 1886.
- Renevier, E.* Rapport sur la marche du Musée Géologique Vaudois en 1886. 8vo. Lausanne, 1887.
- Reyer, E.* Geologie der amerikanischen Eisenlagerstätten (insbesondere Michigan). 4to. Vienna, 1887.
- . Ueber Erstarren. 8vo. Leipzig, 1885.
- Ricciardi, L.* Sull' allineamento dei Vulcani Italiani.—Sulle rocce eruttive sottomarine, subaeree e sottomarine e loro classificazione in due periodi.—Sul graduale passaggio delle rocce acide alle rocce basiche.—Sullo sviluppo dell' acido cloridrico dell' anidride solforosa e del iodio dai vulcani. 8vo. Reggio-Emilia, 1887.
- Rivière, E.* Paléoethnologie. De l'Antiquité de l'Homme dans les Alpes-Maritimes. Livr. 10–12. 4to. Paris, 1886 & 1887. *Purchased*.
- Roberts, Mary.* The Progress of Creation, considered with reference to the present condition of the Earth. 8vo. London, 1846. *Presented by W. Whitaker, Esq., F.G.S.*
- Rohon, J. V., and K. A. v. Zittel.* Ueber *Ceratodus*. 8vo. Munich, 1886.

- Romé de l'Isle, J. B. de. *Essai de Cristallographie*. 8vo. Paris, 1772. *Presented by the Royal Society*.
- . *Cristallographie ou description des formes propres à tous les corps de règne minéral*. Seconde édition. Vols. i.—iii. Text, 8vo. Vol. iv. Atlas, 4to. Paris, 1783. *Presented by the Royal Society*.
- Römer, F. *Die Fossile Fauna der silurischen Diluvial-Geschiebe von Sadewitz bei Oels in Nieder-Schlesien*. 4to. Breslau, 1861. *Purchased*.
- Rondot, N. *Essai sur les propriétés physiques de la soie*. 8vo. 8vo. Paris, 1887. *Presented by Thomas Wardle, Esq., F.G.S.*
- Rosenbusch, H. *Mikroskopische Physiographie der Mineralien und Gesteine*. Zweite Auflage. Band ii. Abth. 1. 8vo. Stuttgart, 1886. *Purchased*.
- Roth, J. *Beiträge zur Petrographie von Korea*. 8vo. Berlin, 1886.
- Russia. *Comité Géologique*. *Bibliothèque Géologique de la Russie*, 1885, No. 1, rédigée par S. Nikitin. 8vo. St. Petersburg, 1886.
- . *Isvestia*. 1886. (Bulletin.) Tome v. Nos. 1–8. 8vo. St. Petersburg, 1886.
- . *Isvestia*. 1887. Tome vi. Nos. 1–5. 8vo. St. Petersburg, 1887.
- . *Mémoires*. Vol. iii. Nos. 2 & 3. 4to. St. Petersburg, 1886.
- Rutot, A., et E. Van den Broeck. *Observations nouvelles sur le Tufeau de Ciply et sur le Crétacé supérieur du Hainault*. 8vo. Liège, 1886.
- Sandberger, F. von. *Pupa (Vertigo) parcedentata-Genesisii und ihre Varietäten-Reihe in der Eiszeit und der gegenwärtigen Periode*. 8vo. Würzburg, 1887.
- . *Ueber einen neuen Pelekypoden aus dem nassauischen Unterdevon*. 8vo. Stuttgart, 1887.
- . *Bemerkungen über einige Heliceen im Bernstein der preussischen Küste*. 8vo. Danzig, 1887.
- Saxony. *Geologische Landesuntersuchung des Königreichs Sachsen*. Erläuterungen zur geologische Specialkarte, Blatt 31, 98, 99, 116, 117, 134. 8vo. Leipzig, 1886.
- Schlüter, C. *Archæocyathus im russischem Silur?* 8vo. Berlin, 1887.
- Schmidt, O. *The Mammalia in their relation to Primeval Times*. 8vo. London, 1885. *Purchased*.

- Schumann, J. Geologische Wanderungen durch Altpreussen. 8vo. Königsberg, 1869. *Purchased.*
- Scudder, S. H. The Cockroach of the Past. 8vo. London, 1886.
- Seguenza, G. Il Lias inferiore nella Provincia di Messina. 4to. Naples, 1885.
- . Monografia delle Spiriferina dei vari piani del Lias Messinese. 8vo. Rome, 1885.
- . Esame di una sezione naturale nel Giurassico di Taormina. 8vo. 1886.
- . Il Lias superiore nel territorio di Taormina. 8vo. Venice, 1886.
- . Il Retico di Taormina. 8vo. Palermo, 1886.
- . Sulla nota del Prof. G. Gemmellaro dal titolo: Sugli strati con Leptæna nel Lias superiore di Sicilia. 8vo. 1886.
- Sherborn, C. D., and F. Chapman. On some Microzoa from the London Clay exposed in the Drainage Works, Piccadilly, London, 1885. 8vo. London, 1886.
- Smythe, G. W. Views and Description of the late Volcanic Island off the coast of Sicily. 4to. London, n. d. *Purchased.*
- South Australia. Colonial and Indian Exhibition, London, 1886. Bibliography of South Australia, compiled by T. Gill. 8vo. Adelaide, 1885.
- . Notes on Geological Map of Gumeracha and Mount Crawford Goldfields, by H. P. Woodward. 4to. Adelaide, 1886. *Presented by the Colonial Government.*
- . ——. ——. *Presented by the Secretary of State for the Colonies.*
- . Report on Geology and Mineralogy of Northern Territory, by J. E. Tenison Woods. 4to. Adelaide, 1886. *Presented by the Secretary of State for the Colonies.*
- . Report on the Ulooloo Goldfield. By H. Y. L. Brown. 4to. Adelaide, 1887. *Presented by the Colonial Government.*
- Spain. Comisión del mapa Geológico de España. Boletín. Tomo xiii. Cuaderno 2. 8vo. Madrid, 1886.
- . ——. Memorias. Descripción física y geológica de la Provincia de Zamora, por G. Puig y Larraz. 8vo. Madrid, 1883.
- . ——. ——. Descripción física y geológica de la Provincia de Alava, por D. Ramón Adán de Yarza. 8vo. Madrid, 1885.
- Spratt, T. A. B. On the Geology of Malta and Gozo. 8vo. Malta, 1852. *Purchased.*

- Spurrell, F. C. J.* On some Palæolithic Knapping Tools and Modes of using them. 8vo. London, 1883.
- . Palæolithic Implements found in West Kent. 8vo. London, 1883.
- . Early Sites and Embankments on the margins of the Thames Estuary. 8vo. London, 1885.
- . A Sketch of the History of the Rivers and Denudation of West Kent, &c. 8vo. Greenwich, 1886.
- Stabile, J.* Fossiles des environs du lac de Lugano. 8vo. Lugano, 1861. *Purchased.*
- Steenstrup, J. J. S.* Kjökken-möddinger. 8vo. Copenhagen, 1886.
- Steinmann, G.* Geologischer Führer der Umgegend von Metz. 8vo. Metz, 1882. *Purchased.*
- Struckmann, C.* Die Portland-Bildungen der Umgegend von Hannover. 8vo. Berlin, 1887.
- Sutcliffe, J.* The Geology of the Avon. 8vo. Bristol, 1822. *Purchased.*
- Svedmark, E.* Några ord med anledning af A. E. Törnebohms referat öfver Kartbladen "Furusund" och "Rådmansö" samt "Gabbron på Rådmansö." 8vo. Stockholm, 1887.
- Switzerland.* *Commission de la Carte Géologique de la Suisse.* Beiträge. Lief. 24. Centralgebiet der Schweiz enthalten auf Blatt xiii., von A. Baltzer, F. J. Kaufmann, C. Moesch, und K. Mayer-Eymar. Erster Theil. Emmen- und Schlierengegenden nebst Umgebungen bis zur Brünigstrasse und Linie Lungerngrafenort, von F. J. Kaufmann. Text and Atlas. 4to. Berne, 1886.
- Symonds, W. S.* Old Stones. 8vo. Malvern, 1855. *Purchased.*
- . Records of the Rocks. 8vo. London, 1872. *Purchased.*
- Tate, R.* Post-Miocene Climate in South Australia. 8vo. Adelaide, 1885.
- . Supplemental Notes on the Palliobranchs of the Older Tertiary of Australia, and a Description of a new Species of *Rhynchonella*. 8vo. Adelaide, 1885.
- . The Lamellibranchs of the Older Tertiary of Australia. Part 1. 8vo. Adelaide, 1885.
- . ——. Part II. 8vo. Adelaide, 1887.
- . A Revision of the Recent Lamellibranch and Palliobranch Mollusca of South Australia. 8vo. Adelaide, 1887.
- . Descriptions of some new Species of South-Australian Marine and Freshwater Mollusca. 8vo. Adelaide, 1887.

- Teall, J.-J. Harris.* British Petrography. Parts 7-10. 8vo. Birmingham, 1886.
- Tolstoi, L. What I believe. Translated by *C. Popoff*. 8vo. London, 1885.
- Toner, J. M. Address before the Rocky-Mountain Medical Association, June 6, 1877, containing some observations on the Geological Age of the World, the appearance of Animal Life upon the Globe, the Antiquity of Man, and the Archæological Remains of Extinct Races found on the American Continent, with views of the Origin and Practice of Medicine among Uncivilized Races, more especially the North-American Indians. 8vo. Washington, 1877. *Presented by W. S. Dallas, Esq., F.L.S.*
- Topinard, P.* Les caractères simiens de la mâchoire de la Naulette. 8vo. Paris, 1886.
- Topley, W.* Report of the Committee on the Erosion of the Sea-coasts of England and Wales. 8vo. London, 1886.
- Umlauft, Fr. Die Alpen. Handbuch der gesammten Alpenkunde. Abth. 1. 8vo. Vienna, 1886? *Purchased.*
- . Die Alpen. Abth. 2. 8vo. Vienna, 1886. *Purchased.*
- United States. *Geological Survey.* Bulletin. Nos. 24-33. 8vo. Washington, 1885 & 1886.
- . ———. Fifth Annual Report (1883-84), by J. W. Powell, Director. 4to. Washington, 1885.
- . ———. Mineral Resources of the United States (1885). 8vo. Washington, 1886.
- . ———. Monographs. Vol. x. Dinocerata, a Monograph of an extinct Order of Gigantic Mammals, by O. C. Marsh. 8vo. Washington, 1886.
- . ———. ———. Vol. xi. Geological History of Lake Lahontan, a Quaternary Lake of North-western Nevada, by J. C. Russel. 4to. Washington, 1885.
- . Geological and Geographical Survey of the Territories. Second Division. Report on the Geology of the Eastern portion of the Uinta Mountains and a region of country adjacent thereto. By J. W. Powell. 4to. Washington, 1876. *Purchased.*
- . *Treasury.* Annual Report of the Director of the Mint, for the year ending June 30, 1886. 8vo. Washington, 1886. *Presented by J. P. Kimball, Esq.*
- . War Department. Corps of Engineers U.S. Army. Report upon the Third International Geographical Congress and Exhibition at Venice, Italy, 1881, accompanied by Data concerning the principal Government Land and Marine Surveys of the World, by *G. M. Wheeler*. 4to. Washington, 1885.

- Victoria. *Department of Mines*. Annual Report of the Secretary for Mines and Water Supply, to the Honourable J. L. Dow, M.P., Minister of Mines for Victoria, on the working of the Regulation and Inspection of Mines and Mining Machinery Act during the year 1885. 4to. Melbourne, 1886.
- . ———. Gold-Fields of Victoria. Reports of the Mining Registrars for the quarter ended 31st March, 1886. 4to. Melbourne, 1886.
- . ———. ———. ——— for the quarter ended 30th June, 1886. 4to. Melbourne, 1886.
- . ———. ———. ——— for the quarter ended 30th September, 1886. 4to. Melbourne, 1886.
- . ———. ———. ——— for the quarter ended 31st December, 1886. 4to. Melbourne, 1886.
- . ———. Mineral Statistics of Victoria for the year 1885. Report of the Secretary for Mines to the Hon. Minister of Mines. 4to. Melbourne, 1886.
- Vilanova y Piera, Juan*. Ensayo de Diccionario geográfico-geológico. 8vo. Madrid, 1884.
- Vogdes, A. W.* Description of a New Crustacean from the Clinton Group of Georgia, with Remarks upon others. 8vo. New York, 1886.
- Vom Rath, G.* Ueber Colemanit. 8vo. Stuttgart, 1885.
- . Vorträge und Mittheilungen. 8vo. Bonn, 1886.
- . Worte der Erinnerung an Dr. Martin Websky. 8vo. Bonn, 1887.
- . Worte der Erinnerung an Professor Dr. A. von Lasaulx. 8vo. Bonn, 1887.
- . Einige geologische Wahrnehmungen in Mexiko. 8vo. Bonn, 1887.
- . Ueber künstliche Silberkrystalle. 8vo. Leipzig, 1887.
- . Ueber Cristobalit vom Cerro S. Cristóbal bei Pachuca (Mexico). 8vo. Leipzig, 1887.
- Wähner, F.* Beiträge zur Kenntniss der tieferen Zonen des unteren Lias in den nordöstlichen Alpen. 2-4 Theil. 4to. Vienna, 1886.
- Wahnschaffe, F.* Die lössartigen Bildungen am Rande des norddeutschen Flachlandes. 8vo. Berlin, 1886.
- . Mittheilungen über das Quartär am Nordrande des Harzes. 8vo. Berlin, 1886.

- Walcher, R. On the Influence of Fluctuations of Atmospheric Pressure on the Evolution of Fire-damp. Translated by G. G. Bagster. 4to. Vienna, 1886. *Purchased.*
- Wardle, T. Les Soies des Vers Sauvages de l'Inde et leur emploi dans l'industrie. 8vo. Paris, 1887. (See also Rondot, N.)
- Warrington, R. A Contribution to the Study of Well-waters. 8vo. London, 1887.
- Western Australia. Report on the Geology of the Kimberley District, Western Australia, by E. T. Hardman. 4to. Perth, 1885. *Presented by John Forrest, Esq., C.M.G., F.G.S.*
- Williams, J. Life in the Soudan: Adventures amongst the Tribes, and Travels in Egypt, in 1881 and 1882. 8vo. London, 1884.
- Winckler, T. C. Histoire de l'Ichnologie. Étude Ichnologique sur les empreintes de pas d'animaux fossiles suivie de la description des plaques à impressions d'animaux qui se trouvent au Musée Teyler. 8vo. Haarlem, 1886.
- Wolterstorff, W. Ueber fossile Frösche insbesondere das Genus *Palæobatrachus*. ii. Theil. 8vo. Magdeburg, 1887.
- Woods, J. E. Tenison. Report upon the Geology and Mineralogy of the Northern Territory of South Australia. 8vo. Darwin, Northern Territory, 1887.
- Woodward, H., and T. Rupert Jones. Fourth Report on the Fossil Phyllopora of the Palæozoic Rocks. 8vo. London, 1886.
- . (Revised.) 8vo. London, 1886.
- Woodward, H. B. Notes on the Geology of Brent Knoll, in Somersetshire. 8vo. Bath, 1887.
- . Notes on the Ham Hill Stone. 8vo. Bath, 1887.
- . The Geology of England and Wales, with Notes on the Physical Features of the Country. Second Edition. 8vo. London, 1887.
- Wright, T. Monograph on the Lias Ammonites of the British Islands. 4to. London, 1878–86. *Bequeathed.*
- Yarkand Mission. Scientific Results of the Second Yarkand Mission; Memoir of the Life and Work of F. Stoliczka, Ph.D., Palæontologist to the Geological Survey of India from 1862 to 1874, by V. Ball. 4to. London, 1886. *Presented by the Government of India.*
- Young, J. Notes on Cone-in-Cone Structure. 8vo. Glasgow, 1885.
- Zittel, K. A. v. Ueber *Ceratodus*. 8vo. Munich, 1886.
- . 1. Ueber *Ceratodus*. 2. Ueber vermeintliche Hautschilder fossiler Störe. 8vo. Munich, 1886.

3. MAPS &c.

The names of Donors in Italics.

- Carez, L., et G. Vasseur. Carte Géologique de France. Feuilles 9, S.O., N.E., S.E.; 10, S.E.; 11, N.O., S.O.; 12, N.E., S.O., S.E.; and 15, N.O., N.E. $\frac{1}{500000}$. *Purchased.*
- France. *Depôt de la Marine.* 4 sheets of charts and plans of various coasts.
- Hesse. *Grossherzoglich hessische geologische Landesanstalt.* Geologische Specialkarte. $\frac{1}{25000}$. Lief. 1. Blatt Messel und Blatt Rossdorf. Darmstadt, 1886.
- Hitchcock, C. H.* Geological Map of the United States and part of Canada, to illustrate the Schemes of Coloration and Nomenclature recommended by the International Geological Congress. 1886.
- New Jersey. *Geological Survey.* Atlas of New Jersey. Sheets Nos. 8, 11, and 12. (G. H. Cook, State Geologist, New Brunswick.) Scale 1 mile to 1 inch. 1887.
- Norway. *Institut géographique de Norvège et la section topographique de l'État Major Général.* Den Geologiska Undersögelse. Karte 15 c and 20 A. $\frac{1}{100000}$.
- Ordnance Survey Maps. *Presented by the First Commissioner of Works.*
 One-inch General Maps. England and Wales. N. S. Outline. 6 Quarter-sheets.
 ———. Ireland (Hills). 2 Quarter-sheets.
 ———. Scotland. 10 Sheets.
 Six-inch County Maps. 22 Sheets; 725 Quarter-sheets.
- Photograph of a Quartzite Pebble found in a Coal Seam, S. Staffordshire (Geol. Mag., July 1873). *Presented by Prof. T. G. Bonney, F.R.S., V.P.G.S.*
- Photograph of the Central Part of the Crater Wall, Pic Rakata, Isle of Krakatau; with a Note by R. D. M. Verbeek. 1886. *Presented by the Count van Bylandt, Netherlands Minister.*
- Photograph of the Section in Mr. Green's Pit, at Sudbury, Suffolk (Geol. Mag., June 1887). *Presented by J. E. Marr, Esq., F.G.S.*
- Photographs of New Zealand Bryozoa, described in papers in Quart. Journ. Geol. Soc. vols. xlii. & xliii. *Presented by A. W. Waters, Esq., F.G.S.*
- Romanovsky, G., et I. Mouchketow.* Carte géologique du Turkestan Russe. Edition 1885. Echelle $\frac{1}{125000}$. Six Feuilles. Fol. St. Petersburg, 1886.

Ruthven, J. Map of the English Lakes and adjoining country, geologically coloured. Scale $3\frac{1}{2}$ miles to 1 inch. 1855. Presented by *W. Whitaker, Esq., F.G.S.*

Saxony. *Geologische Landesuntersuchung des Königreichs Sachsen.* Geologische Spezialkarte. Blatt 31, 98, 99, 116, 117, 134.
 $\frac{1}{250000}$.

Sherwell, W. S. A Geological Map of Zillah Behar. Six miles to an inch. Presented by *W. T. Thiselton Dyer, Esq., C.M.G., F.R.S.*

United States, Geological Map of the, by *C. H. Hitchcock.* 1886.

Wilson, C. H. Mountain Region of British Honduras. Scale, 20 mm.=5 miles. Coloured and uncoloured copies.

II. ADDITIONS TO THE MUSEUM.

Four specimens, bequeathed to the Society by the late Caleb Evans, Esq., F.G.S., viz. :—Two specimens of Elytra of Beetles from the London Clay of Peckham. One specimen of *Palæocorystes glabra*, H. Woodward (Quart. Journ. Geol. Soc. vol. xxvii. p. 90), and one specimen of *Litoricola glabra*, H. Woodward (Quart. Journ. Geol. Soc. vol. xxix. p. 29), both from the Lower Eocene of Portsmouth.

A collection of Rock Specimens of the Rocks of Assouan on the Upper Nile (Geol. Mag. 1886, p. 101, &c.). Presented by *Sir J. W. Dawson, C.M.G., F.R.S., F.G.S., and Prof. T. G. Bonney, F.R.S., V.P.G.S.*

THE
QUARTERLY JOURNAL
OF
THE GEOLOGICAL SOCIETY OF LONDON.

VOL. XLIII.

1. *On the SKULL and DENTITION of a TRIASSIC SAURIAN* (*Galesaurus planiceps*, *Ow.*). By SIR RICHARD OWEN, K.C.B., F.R.S., F.G.S., &c. (Read November 3, 1886.)

[PLATE I.]

IN the year 1858 it was my good fortune to receive from Sir George Grey, K.C.B., Governor of the Cape of Good Hope, a fossil skull from the Triassic sandstone of the Rhenosterberg, which combined dental characters, indicated by the sockets and fragments of teeth, most resembling those of a Carnivorous Mammal, with the unequivocal cranial structure of a Saurian Reptile.

This interesting evidence of the Vertebrate life of that geological period and locality is described and figured in my 'Catalogue of the Fossil Reptilia of South Africa,' 4to, 1876, p. 23, pl. xviii. figs. 6-11, as a species of an extinct genus, *Galesaurus*, and as the type of a Division of the Class REPTILIA, subsequent accessions to which, also described and figured in the same work, led me, by similar modifications of the dentition, to group them in a distinct suborder termed *Theriodontia* (*op. cit.* p. 15).

The collection of fossils from the same formation, in the locality of 'Theba-chou,' Basuto Land, subsequently deposited in the Geological Department of the British Museum of Natural History, by Dr. Exton, which, together with the evidence of a mammalian genus (*Tritylodon*), included remains of the reptilian genera *Kiste-*

cephalus and *Batrachosaurus*, has also furnished the subject of the present paper.

Characters of the skull and teeth, more or less mutilated in the original specimen of *Galesaurus*, have been brought to light by careful removal of the adherent matrix from the present fossil, under the superintendence of my friend Mr. W. Davies, Assistant in the Department.

Cranial and dental characters, so exposed, are given in the annexed drawings of the natural size (Pl. I.); to one of which (fig. 2) is added, in outline, the better-preserved occipital region of the typical specimen of *Galesaurus*, now also in the Geological Department.

In both specimens the reptilian nature of the fossil is exemplified by the single occipital condyle (figs. 2 & 3, 1) and by the degree in which the ex- (2) and supra-occipitals (3) slope forward as they rise to join the parieto-mastoid elements, 7-8. The restricted proportions of the brain are concurrently exemplified by the parieto-frontal ridge-like roof and steeply sloping side-walls of the cranial cavity (fig. 2, 7). The mass of the temporal muscles is indicated by the wide span, 7, of the strong zygomatic arches, the parietal boundaries of which meet and develop a median crest, to which the frontals, 11, also contribute a small proportion. No trace of sagittal suture remains: the chief difference in this part of the cranium from a mature male of a placental or marsupial Carnivore is the retention of the evidence of a primordial "gullet-tract," manifested by the "pineal" or "infundibular" orifice (fig. 2, 7)*. The orbits, *o*, have a strong uninterrupted bony rim, formed above by the pre- (14) and post- (12) frontals, which unite suturally and exclude the mid frontal (figs. 1 & 2, 11); the orbital frame is completed before and below by the lacrymal, maxillary (21), and malar (26) bones. A strong, vertically broad element (8) of the zygomatic arch seems to be excluded from the orbit by a suturally joined malar and postfrontal; the arch bends outward to augment the space for the temporal muscle, and broadly joins the mastoid to form the hind wall of the wide temporal fossa; the muscles so indicated relate to vigorous working of the canine weapons.

The plane of the orbit slopes forward and from above downward and outward (figs. 1 & 2, *o*, *o*). The fronto-nasal suture runs across, in a line with the fore border of the orbits. The nasals (15) diverge anteriorly to form the sides of a single almost terminal outer nostril (*n*), which exposes the fore border of a bony septum. In some other Triassic Reptiles (*Cynosuchus*, c. g.) the nostril is single. The pre-maxillaries complete the nostril. The palatal region (fig. 3) repeats the same general characters as in previously described Theriodonts where it has been exposed, e. g. in *Dicynodon leoniceps* (*op. cit.* pl. xxvi.), *Oudenodon magnus* (*ib.* pl. lvi.), *Oudenodon brevirostris* (*ib.* pl. lviii.).

The pterygo-maxillary vacuities (fig. 3, *y*) are large, but relatively

* See 'Essays on the Conario-hypophysial Tract, and on the Aspects of the Body in Vertebrate and Invertebrate Animals.' By Richard Owen, F.R.S. &c. 8vo, 1883 (Taylor and Francis, Red Lion Court, Fleet Street, London).

less than in the toothless Triassic species quoted. Their proportions and periphery are more nearly repeated by the Crocodiles, among recent forms, than by any known species of Lizard or Chelonian. The pterygoids (fig. 3, 24) divide, with the presphenoid, these vacuities from each other; the diverging fore ends of the pterygoids join the palatal and palato-maxillary boundaries of the posterior nostrils (*palato-nares*). As in the Triassic Dicynodonts and later Crocodilia, the palate is toothless.

The mandible is deep and strong; the rami coalesce at the symphysis; but the sutures between the constituents of the rami are retained, those, for example, between the dentary (32), the angular (30), and surangular (29) (figs. 1 & 3).

The angle of the jaw is not produced, as in the Crocodile, beyond the articular element; in general shape and bony strength the mandible of *Galesaurus* resembles that of a Mammal.

The dentition of the present specimen is in a state of preservation so much better than in the type *Galesaur*, as to call for the present description and illustrations.

The series of upper molars of that fossil (*op. cit.* pl. xviii. fig. 7) were restored as to number in pl. xviii. from remains of the inner enamel-coating of parts of the crown and of the fangs of teeth of the upper jaw. The opposing molars of the lower jaw afforded further indications of molars, and better ones of the canines and incisors. The laniariform character of the canines, their number, position, and relative size, clearly indicate the resemblance of these teeth to their homologues in the carnivorous Mammalia.

In the subject of the present paper the entire crown is preserved in four of the upper molars; the enamelled portion, or crust, shows less length and greater breadth than appears in the above-cited restoration (1876), in which part of the preserved fang is included in the restored outline of the crown. In the perfect molars of the present specimen (fig. 1) the crown shows less length and greater breadth than in the previous restoration; it is moderately convex externally, triangular, with the base flanked by a short cusp before and behind; the corresponding margins of the crown are finely crenulate, as in the molars of *Cynodraco* (*op. cit.* pl. xvii. fig. 6) and *Lycosaurus* (pl. xv. fig. 5, *op. cit.*) An enlarged outline of a perfect upper molar is now given in Pl. I. fig. 4. The incisors with longish, slender, simple-pointed crowns are eight in number in both upper and lower jaws, four in each premaxillary opposed or partially interlocking with the same number in each mandibular ramus; they show a slight increase of size from the first to the fourth. The canines (fig. 1, *c*, *c'*), one on each side of both upper and lower jaws, have the same laniariform shape and size of crown as in the original fossil of *Galesaurus* (*loc. cit.* pl. xviii. fig. 7, *c*). A corresponding interspace for reception of the crowns, the mouth being shut, breaks the dental series. In the right maxillary bone the long, deeply implanted root is exposed; the corresponding part of the lower canine is similarly exposed in the left mandibular ramus. The sum of these characters is shown in the side of the

skull selected for the profile view in fig. 1, Pl. I. No trace of successional teeth, as in ordinary Saurians, has been discovered.

Crocodiles and Alligators, both existing and extinct, have two or more teeth of canine proportions on each side of both upper and lower jaws, the largest and most conspicuous being developed from near the middle of the dental rank*; but these teeth differ in shape from those of Mammalian Carnivores and Galesaurs, have thicker crowns, subcircular in transverse section, chiefly differing in size from the smaller teeth before and behind them. A similar character and disposition of destructive canines is shown by the fossil jaws of the Oolitic great extinct carnivorous Saurians—*Megalosaurus*, for example. In the Triassic Labyrinthodonts the destructive and prehensile laniaries occupy the foremost end of the dental series, are four in number, two on each side, and by position in the lower jaw would rank as “incisors” rather than canines †.

In the poisonous Snakes the canines, in number and position, resemble those in the upper jaw of carnivorous Mammals, but are limited to that locality, and have the well-known modifications of structure and attachment in purposive relation to the infliction of a venomous wound ‡.

As a rule the dental series, in existing Lizards, shows teeth of nearly uniform shape, and either similar in size (see figs. 1, 2, 3, 4, pl. lxvi., ‘Odontography,’ vol. ii.), or gradually increasing, chiefly in breadth of crown, from before backwards (figs. 6, 7, *loc. cit.*). Moreover the cement-clad roots contract bony union with the jaw-bones, both upper and lower; whilst in *Galesaurus* the teeth, besides being distinguished, as in Mammals, by their differential character as incisors, canines, and molars, are implanted freely in sockets of due depth, the cold-blooded characters being manifested solely by the greater number of teeth following the canines, and by the absence of those developmental and formal distinctions which enable the naturalist to classify them, in Mammals, as “premolars” and “molars.”

Here, however, I may remark that some extinct Mammals of the Oolitic period have retained the earlier Reptilian character of the, geologically, older subject of the present communication. I refer to the excess of number of the molar teeth in *Amphitherium* (Brit. Foss. Mammals, 8vo, 1846, p. 29. fig. 15, p. 44. fig. 16), a character still retained in the existing Australian *Myrmecobius*. *Galesaurus* also resembles that and other Marsupials§ in the number and relative size of its upper incisors, while retaining the same number below.

One cannot rise from these comparisons without speculating on the association of the degree or mammalian dental resemblances manifested by the teeth of the old Triassic Reptile at the southern

* ‘Odontography,’ vol. ii. (Atlas), pl. 75 a. figs. 1 & 2.

† *Tom. cit.* pl. 63 a. figs. 4 & 5.

‡ *Tom. cit.* pl. 63. figs. 8, 9, 13.

§ *Tom. cit.* pl. 98. fig. 1, *Thylacinus*; fig. 2, *Dasyurus*; fig. 3, *Phascogale*; fig. 4, *Myrmecobius*.



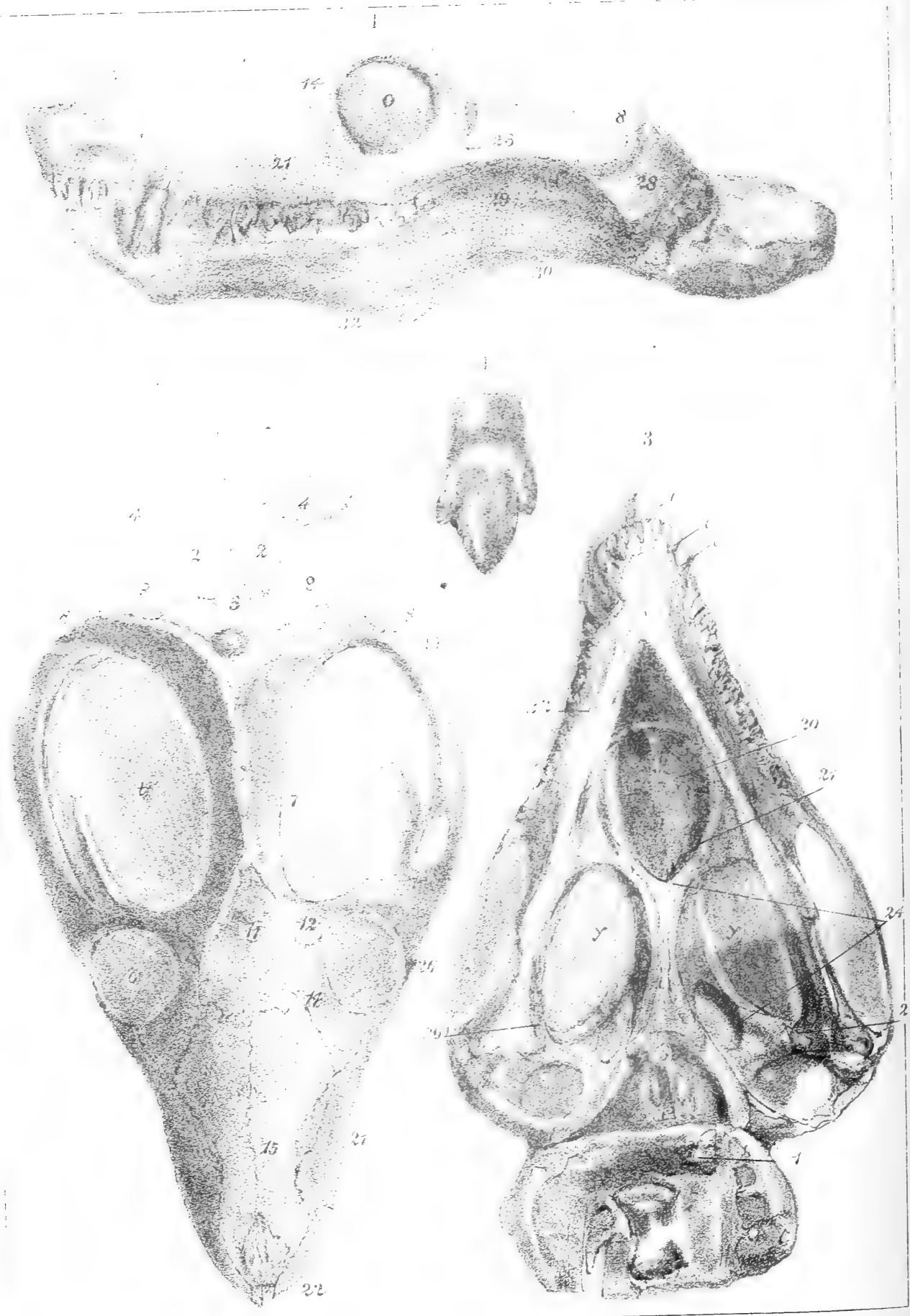

end of Africa with the exceptional incisory and molar characters of some of the low Australian forms of Mammals still in existence at the Antipodes.

EXPLANATION OF PLATE I.

Skull of *Galesaurus planiceps*, Ow.

- Fig. 1. Side view.
 2. Top view.
 3. Base view.
 4. Magnified view, outer side, of molar tooth.

(All the figures, save 4, are of the natural size.)

DISCUSSION.

The PRESIDENT referred to the skilful work of the masons in the British Museum, under the able direction of Mr. William Davies, and was glad to find that the Author's previous suggestions as to structure were fully confirmed.

Mr. CRUTTWELL questioned the Triassic age of the South-African beds in question. They were in conformable sequence to beds full of undoubted Carboniferous fossils. Might not *Galesaurus* rank as a Carboniferous Amphibian?

Prof. SEELEY remarked on the admirable description of this species which the Author had given, and regretted that he was unable to concur in the conclusions as to its classification. He contended that the term Theriodontia used for this animal and its allies was based on resemblances of analogy which did not imply affinity, and that other reptile types had as good a claim to be termed Theriodont from resemblances to other mammalian forms of dentition, and it would be absurd to institute ordinal groups for them. He maintained that the developed tooth in the position of a canine, in these fossils, was not a character on which an order could be based. Spencer's investigation of the organ resembling an eye which occupies the parietal foramen gave new interest to its presence in the fossil, but the character was not Therioid. In the construction of the palate he found no difference of plan from the other Anomodontia. There were differences from Lizards in the mode of union of the pterygoid bones with the sphenoidal mass; but the fossil showed no distinctive type in this region. He urged that the mammalian resemblance noted in the form of the brain-case was equally delusive; for although *Procolophon* was far from being the nearest ally of *Galesaurus*, he thought the resemblance between them in the fore part of the skull, in the divided nares and forms of the bones, justified him in saying that there was no more difference between those genera than differentiated, in another order, the Chelonian genus *Chitra* from the Sea-Turtle, *Chelone*. He therefore considered it unfortunate that an ordinal group, Theriodontia, should have been instituted for these Anomodonts.

Prof. T. RUPERT JONES said that the Stormberg beds, in which the *Galesaurus* is found, lie somewhere between Palæozoic and

Mesozoic, and he expressed his doubts as to the Palæozoic fossils which were alleged to have been found.

Mr. LYDEKKER confirmed the remarks of Prof. Seeley, and expressed his regret that Sir R. Owen had not described one other specimen in the British Museum. It would be sufficient to regard these fossils as constituting a suborder only.

Dr. WOODWARD thought that thanks were due to Dr. Exton, and remarked on the difficulty of getting specimens from Bloemfontein; exchanges of this kind were valuable. He instanced the acquisition of *Tritylodon* and fish-remains not previously known. He differed as to the Carboniferous age of the beds, and considered that the Trias would represent the extreme of their possible antiquity.

Dr. BLANFORD said that he had protested against the term Triassic on the last occasion when Sir R. Owen had described a mammalian skull from the Stormberg beds, and he still thought it a matter for regret that these interesting fossils were definitely assigned to a particular geological system, although it was notorious that the evidence of age was far from clear. The speaker pointed out that some remarkable similarities in Indian beds, and the asserted presence in the Stormberg beds of plants common to the Jurassics of Australia, indicated that the beds from which *Galesaurus* was obtained were at least as likely to be Jurassic or even Neocomian as Triassic. *

Mr. CRUTTWELL referred to the abundance of Carboniferous plants which might be observed at Newcastle and Dundee, in Natal, and he repeated that the Karoo beds may be seen to overlie these in sequence on the route from Camden to Prætoria.

The PRESIDENT regretted that the Author, through illness, was not able to be present to reply to the criticisms as to the systematic position of these forms and the geological age of the beds in which they occur.

2. *The CETACEA of the SUFFOLK CRAG.* By R. LYDEKKER, Esq.,
B.A., F.G.S., &c. (Read November 3, 1886.)

[PLATE II.]

THE fossil Cetacea of the Suffolk Crag have already formed the subject of several memoirs and papers, although no complete treatise has as yet appeared on the whole group. Of the more important memoirs the earliest is one by the late Prof. Henslow, which appeared in the Society's 'Proceedings' for 1843*, and contains a description by Prof. Sir R. Owen of four specimens of the tympanics of the *Balœnidæ*. In Sir R. Owen's 'History of British Fossil Mammals and Birds' (1846) these specimens are again described, and the genus *Balœnodon* is founded on the evidence of an imperfect tooth. In 1864 Prof. E. Ray Lankester † published a paper on Crag fossils containing a notice of some delphinoid remains; while in another memoir, which appeared during the same year in the Society's 'Journal' ‡, Prof. Huxley described the rostrum of one of the Ziphoids under the new generic title of *Belemnoziphius*. In 1870, Sir R. Owen contributed a monograph of the Ziphoids to the Palæontographical Society; and in the latter part of the same year Prof. Lankester § published the description of a rostrum belonging to the same group. Finally, in 1884, Prof. Flower, in part 2 of the 'Catalogue of the Vertebrata in the Museum of the Royal College of Surgeons,' provisionally referred a considerable number of tympanics of *Balœnidæ* to the four species determined by Sir R. Owen, without entering into the question of the correctness of the generic determination. Two specimens were, however, regarded as distinct from all these four species; one of these was referred to *Balœna* and the other to *Balœnoptera*. Some incidental references to Crag Cetacea occur in the works of foreign palæontologists, which need not be definitely quoted.

In the course of preparing the 'Catalogue of the Fossil Mammalia in the British Museum,' I have been led not only to examine every specimen of the remains of Crag Cetacea contained in that collection, but have also examined the collections of the Museum of the Royal College of Surgeons, of the Museum of Practical Geology, and of the Ipswich Museum; and I have also paid a visit to the Brussels Museum in order to compare the unrivalled collection of Pliocene Cetacea contained in that institution with the English specimens ||.

* Proc. Geol. Soc. vol. iv. pp. 283-286.

† Ann. & Mag. Nat. Hist. ser. 3, vol. xiv. p. 356.

‡ Quart. Journ. Geol. Soc. vol. xx. p. 388.

§ *Ibid.* vol. xxvi. p. 502.

|| I desire to express my obligations to the Director-General of the Geological Survey, and Mr. E. T. Newton, of the Museum of Practical Geology, to Dr. J. E. Taylor, of the Ipswich Museum, and to the Director and M. L. Dollo of the Brussels Museum, for their courtesy in placing the collections under their charge at my disposal, as well as for the opportunity of borrowing some of the most important specimens.

As the result of these extensive comparisons, I have been able not only to add a considerable number of species to the British fauna, but to make several important emendations in regard to nomenclature, and also as to the affinities of certain forms which have hitherto been but very improperly known; and I have accordingly thought it advisable (with the permission of the Director and the Keeper of the Geological Department of the British Museum) to bring these results in a collective form under the Society's notice. I think I may be congratulated that I have not found it necessary to make any new species.

Before proceeding to the descriptive part of the paper it may be advisable to state that my own observations fully confirm the conclusions arrived at by Prof. Lankester, as to the essentially Diestian affinities of the English Crag Cetacea. In the Coralline Crag the specimens are usually met with in an unrolled condition; and although the remains found in the bone-bed at the base of the Red Crag are much rolled and water-worn, yet specimens belonging to the same species are found occasionally in the upper portions of that deposit, in a more or less uninjured condition, which clearly proves that such species were inhabitants of the Pliocene sea during the deposition of the Red Crag. With these introductory remarks the consideration of the fossils themselves may be undertaken*.

Balænidæ.—Commencing with the Balænine section of the family, it appears to me to be advisable to include in the genus *Balæna* both *Balænotus* and *Balænula* of Van Beneden, as these forms seem to be nothing more than primitive Right Whales, in which the ankylosis of the cervical vertebræ had not attained the full development characteristic of the existing forms. Of the four tympanics described by Sir R. Owen in the fourth volume of the Society's 'Proceedings,' and in the 'British Fossil Mammals and Birds,' under this generic designation, the only one that really belongs to *Balæna* is *B. affinis*. The type-tympanic is not of very large size, but there are specimens in the British Museum (*e. g.* No. 46681) corresponding in form which indicate a species fully as large as, and apparently closely allied to, the Greenland Whale; there are similar specimens in the Brussels Museum which have been referred to *B. primigenia*, Van Beneden (a reference which, if correct, would indicate that the latter name is a synonym of *B. affinis*), but which differ from typical tympanics of that species. The tympanic of *B. affinis* is characterized by its elongated shape and flat anterior surface, its nearly straight inferior border, which is approximately parallel with the superior border of the inner wall, the height of the inner wall at the Eustachian part of the aperture, the produced antero-inferior angle, and the slight thickening of the involucreum †.

In addition to this type of tympanic the Red Crag contains numerous examples of the tympanics of other large Whales, which in their convex inferior border, absence of a produced antero-inferior

* As the references to the nomenclature will be given in the British Museum Catalogue, it will be unnecessary to quote them in this paper.

† The reflected superior portion of the inner wall.

angle, and the comparative lowness of the Eustachian portion of the aperture agree with the existing Whales of the southern and temperate oceans (*B. biscayensis* and *B. australis*). Very great variation in respect of certain details is found in this type of tympanic, the difference between extreme examples being so great that if we had only a few specimens to deal with, it would be necessary to refer them to more than one species; but in a large series it is found that these variations apparently pass imperceptibly into one another, and all the forms are therefore provisionally referred to one species, which is *B. primigenia* of Van Beneden. In the typical form of tympanic*, which we may call variety A, the inner wall is very high, its superior border oblique, the flattening of the anterior surface extending nearly or quite down to the border, the involucrem considerably thickened, and the inferior border somewhat angulated. There is a very perfect immature tympanic of this specimen in the British Museum (No. 46686), which was identified several years ago by Prof. Van Beneden, and there are others in the Museum of Practical Geology, and in the Ipswich Museum, and one fine example in the Museum of the College of Surgeons (No. 2831). By the courtesy of Mr. Colchester, of Ipswich, I figure (woodcut, fig. 1) a

Fig. 1.—*Balæna primigenia*, Van Beneden, var. A. The imperfect right tympanic; from the Red Crag. Half nat. size.

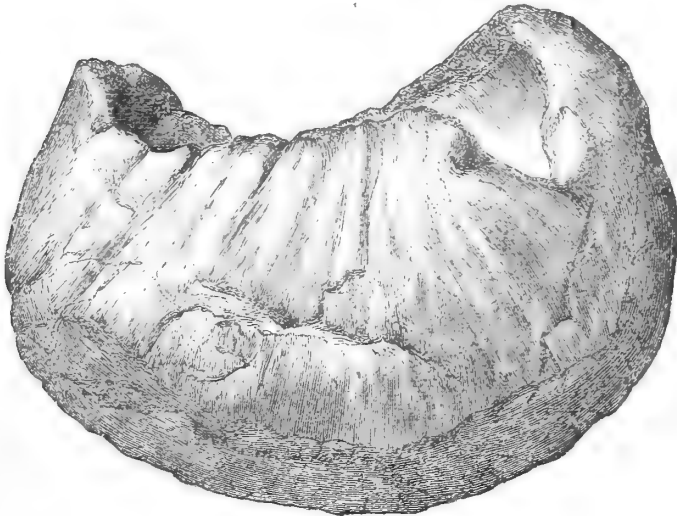

specimen of a right tympanic of this type, which has not been subjected to rolling. In this specimen (of which a cast has been taken by Mr. Colchester's permission for the British Museum) the obliquity of the superior border of the inner wall is only moderate.

In the form which may be called variety B, of which there is a very fine example in the Museum of Practical Geology (Pl. II. figs. 1, 1*a*), the obliquity of the superior border of the inner wall is excessively developed, although most of the other characters are

* See Van Beneden, Ann. Mus. R. Hist. Nat. Belg. vol. iv. pt. 2, pl. xix, figs. 1-4 and 9-12.

similar to those of the type form. This very remarkable type of tympanic presents an approximation to the still more remarkable tympanic of the genus *Neobalæna*, the resemblance being so decided as to indicate the probability of there having been a genetic connection between the two forms. The form which I note as variety C is represented by a tympanic in the British Museum (No. 46685), which, while agreeing in many respects with the type-form, is distinguished by its extreme lateral compression and the total absence of any thickening of the involucreum.

The last variety, which we may term D, is characterized by the lowness of the inner wall, the parallelism of its superior border to the long axis of the bone, the slight downward extent of the flattening of the anterior surface, and the absence of any distinct angulation of the inferior border. There is a fine example of this form in the British Museum (Pl. II. figs. 2, 2a), and a smaller one in the Museum of Practical Geology. It is not always easy to distinguish between some of the smaller tympanics of this type and those of *B. insignis*; but those of the latter are usually more inflated, thicker inferiorly, and with a distinct angulation of the inferior border. Tympanics agreeing with those of *B. (Balænotus) insignis* and *B. (Balænula) balænopsis*, Van Beneden, occur in the Red Crag; and the British Museum possesses an atlas vertebra (No. M. 3542) from the Coralline Crag referred by Professor Van Beneden to the latter species. Both these Whales are of small size, but *B. balænopsis* is the smaller of the two. Prof. Van Beneden mentions certain structural differences by which the tympanics of these two species can be distinguished; but I confess that I was unable to satisfy myself of the validity of such distinctions from an examination of the type specimens in the Brussels Museum: in naming the Crag specimens, I have been forced to content myself with referring the smaller ones to *B. balænopsis*, and the larger to *B. insignis*; and it is difficult, in the case of some immature specimens, to say whether they may not belong to young individuals of the larger species. There is a very beautiful example of the right tympanic of the former species, which was obtained from the Red Crag of Woodbridge, preserved in the Ipswich Museum. The tympanic of *B. insignis* frequently exhibits a flattening of the inferior surface which recalls the structure obtaining in the following section.

In the Balænopteryne section, which is characterized by the absence of ankylosis of the cervical vertebræ and the more inflated and rounded tympanic, in which the Eustachian channel is usually well defined, it may be observed that a very large number of genera and species have been founded by Prof. Van Beneden on the evidence of remains from the Antwerp Crag. Some of these forms have not yet been figured, and their names are therefore little better than MS. ones; while in those which have been fully described it appears to me that some of the generic divisions are unnecessary, and I cannot help thinking that in certain instances some of the forms to which specific names have been applied are not improbably only individual or sexual variations; but as it is impossible to prove this,

I cannot but adopt such species*. In regard, however, to the names applied to two of these species, it is necessary to replace those given by Prof. Van Beneden by the earlier Owenian ones. It may be added that the great number of species in this section renders the specific determination of detached vertebræ in many instances a matter of great difficulty and uncertainty; and it may also be mentioned that owing to the more fragile nature of the outer wall of the tympanic in the Rorquals, fairly perfect specimens of these bones are much less common in the Red Crag than in the case of the Right Whales.

In the genus *Megaptera* (in which the tympanic is more inflated and its involucre more pear-shaped than in *Balænoptera*) we may, I think, certainly include the genus *Burtinopsis* of Van Beneden, which has been described as intermediate between *Megaptera* and *Balænoptera*, although the tympanics figured by Van Beneden † are undistinguishable in structure from those of *Megaptera boops*. To *Megaptera affinis*, Van Beneden, I provisionally refer an immature right tympanic (Pl. II. figs. 4, 4 a) from the Coralline Crag, which is preserved in the Museum of Practical Geology, and in its blunted anterior extremity agrees very closely with the larger example figured by Van Beneden in the Ann. Mus. R. Hist. Nat. Belg. vol. vii. pt. 3, pl. xliii. figs. 1, 2.

A left periotic, from the Red Crag, in the British Museum (No. 39020), from the narrow and elongated form of the portion containing the semicircular canals, evidently belongs to the present genus (as distinct from *Balænoptera* and *Cetotherium*); and as it is apparently adult, and much smaller than the corresponding bone of *M. affinis* figured by Van Beneden in the Ann. Mus. R. Hist. Nat. Belg. vol. vii. pt. 3, pl. xlii. fig. 4, and is apparently too large for *M. (Burtinopsis) minuta*, Van Beneden, the probability is that it belongs to the somewhat larger *M. (Burtinopsis) similis*, Van Beneden. The small *M. minuta* is represented by a nearly perfect left tympanic (Pl. II. figs. 5, 5 a) from the Coralline Crag, which is preserved in the Ipswich Museum, and agrees exactly with the tympanic figured by Van Beneden, *op. cit.* pl. xcvi. figs. 9–11, under the name of *Burtinopsis*. Except by its smaller size, the English specimen can scarcely be distinguished from the tympanic of the existing *M. boops*.

To the genus *Balænoptera* belongs the so-called *Balæna definita*, Owen, of which there is a fairly perfect tympanic in the Ipswich Museum (Pl. II. figs. 3, 3 a). This specimen agrees exactly with the imperfect type tympanic (of which a cast is preserved in the Museum of the College of Surgeons ‡); and as it differs from the corresponding bone of *B. Goropi*, Van Beneden, by its larger size, its

* In many instances it does not appear to me by any means certain that the vertebræ belong to the same species as the tympanics, and it is therefore advisable to regard the latter as the types of such species.

† Ann. Mus. R. Hist. Nat. Belg. vol. vii. pt. 3, pls. lxxxix. & xcvi. The recent tympanic figured in pl. lxxxix. figs. 15, 16, under the name of *Balænoptera antarctica*, certainly belongs to *Megaptera boops*, and might have been drawn from a specimen in the British Museum (No. 2.76.16.18).

‡ Nos. 2805 and 2832 in the same collection belong to this species.

greater inflection, greater height of the inner wall, smaller depth of the Eustachian notch, sharper posterior angle, and more gibbous involucre, there is little doubt of its specific distinctness, and every probability of its being identical with the so-called *B. Sibbaldina*, Van Beneden, of which the tympanic has been hitherto unknown. This is confirmed by a very fine late cervical vertebra from the Red Crag in the Ipswich Museum, which corresponds exactly with the type specimens of the latter form in the Brussels Museum. The rather smaller *B. Goropi*, Van Beneden*, is represented by an imperfect tympanic from the Red Crag, in the British Museum (No. 39016), and probably by some vertebræ in the same collection. Of the still smaller *B. borealina*, Van Beneden, there is an imperfect tympanic (of which the British Museum has a cast) in the Ipswich Museum, from the Red Crag, as well as two similar specimens in the British Museum (Nos. 3907-8). The next form is that named by Owen *Balæna emarginata* (with which *B. gibbosa*, Owen, appears to be identical†), which is represented by several tympanics in the Museum of the College of Surgeons‡, and by one in the British Museum (No. 39016 a); these specimens are absolutely undistinguishable from the tympanics found in the Antwerp Crag, which Van Beneden has named *Balænoptera rostratella*, a name which must give place to the earlier one applied by Owen, so that the species must be known as *Balænoptera emarginata*. With regard to the genus *Plesiocetus* of Van Beneden, I think it advisable to adopt Brandt's view of including it in his genus *Cetotherium*, with which *Heterocetus* §, Van Beneden, may also apparently be grouped. The tympanic is readily distinguished from that of *Balænoptera* by its anteriorly pointed form, the triangular shape of the roughened inferior surface, and the less flattened involucre. To *C. Brialmonti* (Van Beneden) I refer an imperfect axis-vertebra from the Red Crag, in the British Museum (No. 46734); while the smaller *C. dubium* (Van Beneden) is represented by two imperfect tympanics in the Museum of the College of Surgeons (Nos. 2852, A and B)||, and probably by some periotics in the British Museum (*e. g.* No. 30261). Some vertebræ in the latter collection probably belong either to this species or to *C. Burtini* (Van Beneden); while others which belong either to the latter or to *C. Hupschi* (Van Beneden) I have provisionally referred to the last-named species. The still smaller *C. brevifrons* (Van Beneden ¶) is represented by an axis-vertebra in the British, and another in the Ipswich Museum, while it is not

* Syn. *B. musculoïdes*, Van Beneden; the reasons for adopting the former name will be given in the Cat. Foss. Mamm. Brit. Mus. pt. v.

† The form of the involucre on which Owen distinguished this second species alters with age.

‡ Nos. 2822-2825. Some of the other specimens included under the same head are distinct.

§ This is really not more than a MS. name.

|| These numbers do not appear in the published 'Catalogue,' but have been entered in MS. by Dr. Garson in the Museum copy.

¶ Syn. *Heterocetus brevifrons*. The type specimens are not figured, and I have identified the English examples by comparison with those in the Brussels Museum.

improbable that a small tympanic in the latter collection may also belong to this species. A tympanic from the Red Crag, in the Museum of Practical Geology (represented by a cast in the British Museum), indicates the occurrence of *Herpetocetus scaldiensis*, Van Beneden, in this country, and No. 2816 * in the Museum of the College of Surgeons is a second example. The tympanic of this genus (which exhibits some affinity in the structure of the mandible with the *Physeteridæ*) is readily recognized by its egg-like shape, the small and sharply defined involucrum, and the filling-up of the anterior portion of the cavity by osseous matter.

Physeteridæ.—In the *Physeteridæ* the periotic † (which, as in the other families of the Odontoceti, is not ankylosed to the tympanic) articulates anteriorly by a smooth facet (*a*, Pl. II. fig. 6) with the tympanic, and posteriorly is broad and has a distinct median longitudinal ridge (*b*) on the same face for articulation with the free border of the latter bone. The genus *Eucetus*, Du Bus, which appears to be allied in dental characters to *Physeter*, is represented

Fig. 2.—*Eucetus amblyodon*, Du Bus. The left periotic; from the Red Crag. Two thirds nat. size. British Museum (No. 27854). Letters as in Plate II.

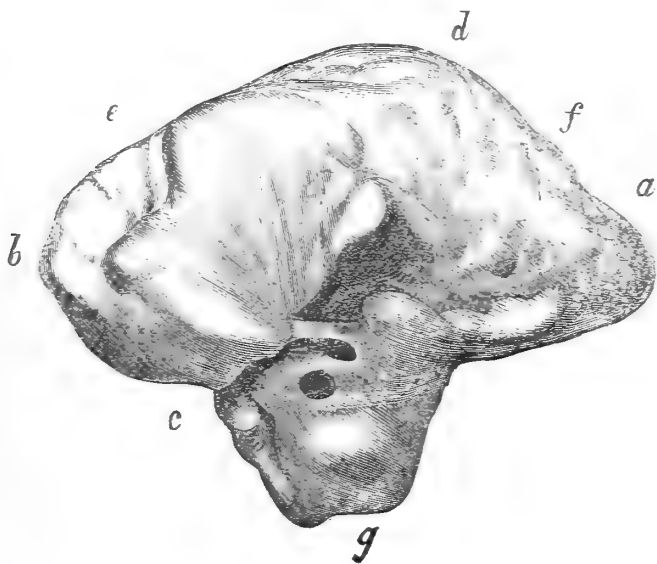

in nearly all Crag collections by many teeth, which belong to the type species *E. amblyodon*; the cement is of great thickness, the dentine-core fusiform, and the osteodentine nodular. I provisionally refer to this species ‡ a large left periotic in the British Museum (woodcut, fig. 2), which in the partial production of its posterior extremity more nearly resembles the periotic of *Hyperoodon* than

* Entered in the Catalogue under the head of *Balæna defnita*.

† While the tympanic is the most characteristic bone in the *Balænidæ*, the periotic (which is more commonly preserved in the fossil condition) is the one affording the best generic characters in the *Physeteridæ* and *Delphinidæ*.

‡ On account of its large size and the circumstance that teeth of *Eucetus* are much commoner than those of *Balænodon*.

that of *Physeter*, and thus, if rightly referred, confirms the generic distinctness of the present form from the latter. The small *Homotetus Villersi*, Du Bus, is, I believe, represented by a tooth from the Red Crag, in the British Museum (No. 49966), and not improbably by other teeth in the Ipswich Museum.

I now come to the genus *Balænodon*, Owen, which was founded upon an imperfect tooth, whose affinities have given rise to much discussion*. In describing the type specimen, Owen regarded it as a segment of a complete tooth, and described the central axis as dentine, and the outer coat as cement; but a comparison with teeth in the Brussels Museum, to which Du Bus applied the name of *Scaldicetus Carreti*, has shown that the cement has entirely disappeared, and that the axis is really the ossified pulp-cavity, and the outer coat the dentine. The English specimen is specifically identical with the Belgian ones, and the name *Balænodon* must therefore supersede *Scaldicetus*. The complete teeth of the genus have their crowns tipped with enamel. Of the allied but smaller genus *Physodon* †, Gervais, there are teeth in the British Museum from the Red Crag corresponding to those of *P. grandis* (Du Bus), while one imperfect tooth (No. 44109) may not improbably belong to *P. fusiformis* (Du Bus). The genus *Hoplocetus* comprehends other *Physeteroids* with enamel-tipped teeth, which are characterized by the excessive thickness of their cement and the presence of a constriction at the base of the crown. Certain worn (and probably derived) teeth from the Red Crag in the British Museum and other collections appear to indicate the occurrence of the Miocene *H. crassidens*, Gervais, while others may be referred to the Diestian *H. borgehoutensis*, Gervais, and others, again (more doubtfully), to *H. curvidens* of the same epoch.

In the *Ziphiine* subfamily *Hyperoodon* is represented by a very perfect right periotic from the Red Crag in the Ipswich Museum (Pl. II. fig. 6). This specimen, which has the accessory ossicle (*c*) still attached, cannot be distinguished from the corresponding bone of the existing *H. rostratus*, and evidently indicates the existence either of that or of a closely allied form in the Pliocene; the occurrence of cervical vertebræ of a member of this genus in the Antwerp Crag has been recorded by Prof. Van Beneden ‡. The genus *Choneziphius*, which appears to be in some respects intermediate between *Hyperoodon* and *Mesoplodon*, and differs from the latter by the non-ossification of the supravomerine cartilage, is represented by the typical *C. planirostris* (Cuv.). The so-called *Ziphius planus*, Owen, also belongs to the same genus, but the type specimen of that species is not sufficiently perfect to determine whether *Choneziphius Packardi*, Lankester (which is of rather later date), is really entitled to specific distinction. I refer to this genus a left periotic (Pl. II. fig. 7) from the Red Crag, preserved in the Museum of Practical Geology, which

* Gervais identified *Balænodon* with *Hoplocetus*, while Van Beneden and Lankester thought it might be a *Squalodon*.

† Syn. *Palæodelphis*, Du Bus.

‡ Bull. Ac. R. Belg. sér. 2, vol. x. p. 407 (1860).

is intermediate between the corresponding bone of *Hyperoodon* and that of *Mesoplodon*, and accords well in relative size with the present genus. This bone (in which the accessory ossicle (*c*) is absent) is nearer to that of *Mesoplodon* than to *Hyperoodon*, but approaches the latter in the shortness of the posterior extremity, the large size of the cavity for the accessory ossicle, and the great development of the longitudinal ridge (*b*) on the tympanic aspect of this portion; the anterior articular facet (*a*) for the tympanic is also less concave than in *Mesoplodon*. The latter genus may be taken to include both *Belemnoziphius* of Huxley and those Crag species placed by Owen in *Ziphius* which do not belong to *Choneziphius*. With regard to species, the identity of Owen's *Z. medilineatus* with *Diopledon Becani*, Gervais, of the Antwerp Crag, has been shown by the latter writer; and as my own observations in the Brussels Museum fully confirm the view expressed by Du Bus as to the identity of the latter with *Ziphius longirostris*, Cuvier (the locality of the type specimens of which is unknown), I think we can have no hesitation in adopting the name of *Mesoplodon longirostris* for this species, which agrees in size with the existing *M. australis*. A left periotic (Pl. II. fig. 8) belonging either to this or one of the equal-sized species, is preserved in the Jermyn-Street Museum, and is almost undistinguishable from the corresponding bone of *M. australis*; the accessory ossicle on the posterior portion of the tympanic aspect is absent in the fossil. The characteristic features of the periotic of *Mesoplodon* are the production and pointed extremity of the posterior portion, the comparatively small vertical height of the longitudinal articular ridge on the tympanic aspect of the same, the small size and oval shape of the accessory ossicle, and the deep transverse concavity of the anterior articular facet for the tympanic. The other described Crag species are *M. tenuirostris* (Owen), *M. gibbus* (Owen), *M. angustus* (Owen), *M. angulatus* (Owen), and *M. compressus** (Huxley); and to these may perhaps be added a form of which there is a rostrum in the Ipswich Museum to which the MS. name of *M. Floweri* has been applied by Mr. Canham †.

Squalodontidae.—The Crag *Squalodon*, of which there are several molar teeth in the Ipswich Museum, may in all probability, as Prof. Lankester suggests, be identified with the large *S. antwerpiensis*, Van Beneden.

Delphinidae.—The periotic of this family (Pl. II. fig. 11) is distinguished by the grooving of the anterior facet (*a*) for articulation with the tympanic, and the narrowness of the posterior tympanic surface, on which the ridge for articulation with the free border of the tympanic is ill-defined and situated close to one edge. The occurrence in the Red Crag of an *Orca* considerably smaller than the existing *O. gladiator* is indicated by a right periotic (Pl. II. fig. 9) in the Museum of Practical Geology, and by an unworn and very perfect tooth (Pl. II. fig. 10) collected by Dr. J. E. Taylor and preserved

* *Belemnoziphius compressus*, Huxley, appears identical with *Ziphius compressus*, Owen.

† See Flower, Cat. Vert. Mus. R. Coll. Surg. pt. 2, p. 562, No. 2915 (1884).

in the Ipswich Museum. The periotic agrees very closely in structure with a specimen of the corresponding bone of *O. gladiator* in the Museum of the College of Surgeons, and accords in relative size with the tooth. As I am unable to distinguish the latter from the teeth of the small *Orca citoniensis*, Capellini*, from the Pliocene of Italy, I am disposed to refer the English form to that species. The next form for consideration is that to which Prof. Lankester† applied the name *Delphinus uncidens* (the generic term being used in the Linnean sense), with which *D. orcooides* of the same author may be united, since the larger teeth to which the latter name was applied are merely the hinder ones of the same species. Some confusion occurs in the description of the larger teeth, since they are stated to agree in size with those of *Pseudorca* and *Orca*‡, whereas they really correspond in this and other respects with those of *Globicephalus*, to which genus they may be referred. The evidence for this reference does not, however, depend solely upon the teeth, since there is in the British Museum a very beautiful associated left periotic and tympanic from the Coralline Crag (the former bone being represented in Pl. II. fig. 11), which agree precisely in size with the corresponding bones of *G. melas*, and only present slight structural differences of specific value. Rolled periotics and tympanics of this type are of extremely common occurrence in the Red Crag, an example of the former being represented in pl. viii. figs. 2, 3 of Prof. Lankester's memoir. To render the foregoing evidence absolutely conclusive, the British Museum possesses a lumbar vertebra (No. 28271) from the Red Crag which is undistinguishable from the corresponding bone of *G. melas*. There are several less perfect vertebræ of the same type in the latter collection, while some unnamed vertebræ in the Brussels Museum apparently indicate the occurrence of the same species in the Antwerp Crag. The last form I have to notice is one indicated by numerous periotics and tympanics in the British Museum and other collections, which indicate a Dolphin agreeing in size with the existing *Lagenorhynchus acutus*; I have not, however, been able to determine the genus of this type, which may include more than one species, and may be identical with one or both of two Belgian species to which Prof. Van Beneden has applied the name of *Delphinus Wasii* and *D. Delannoyi* (the generic term being used in a wide sense). The specimens in the Brussels Museum do not, however, include any examples of the periotic, so that I could not institute any comparison between the Belgian and the English specimens.

I may conclude this paper with a list of the well-authenticated § species of Cetacea occurring in the Red and Coralline Crag, those species of which the identification is doubtful being indicated by a query.

* Mem. Ac. Sci. Ist. Bologna, ser. 4, vol. iv. p. 670 (1883).

† Ann. & Mag. Nat. Hist. ser. 3, vol. xiv. p. 356 (1864).

‡ Mentioned as species of *Delphinus* in Prof. Lankester's memoir.

§ I omit a few forms which have been erroneously recorded from the Crag or of which the description is too vague to admit of identification.

BALÆNIDÆ.

- Balæna affinis*, Owen.
 — *primigenia*, Van Beneden.
 — *insignis* (Van Beneden).
 — *balænoopsis* (Van Beneden).
Megaptera affinis, Van Beneden.
 — ? *similis* (Van Beneden).
 — *minuta* (Van Beneden).
Balænoptera definita (Owen).
 — *Goropi*, Van Beneden.
 — *borealina*, Van Beneden.
 — *emarginata* (Owen).
Cetotherium Brialmonti (Van Beneden).
 — *dubium* (Van Beneden).
 — ? *Hupschi* (Van Beneden).
 — *brevifrons* (Van Beneden).
Herpetocetus scaldiensis, Van Beneden.

PHYSETERIDÆ.

- Eu cetus amblyodon*, Du Bus.
Homocetus Villersi, Du Bus.
Balænodon physaloides, Owen.
Physodon grandis (Du Bus).
 — ? *fusiformis* (Du Bus).
Hoplocetus crassidens, Gervais.
 — *borgehoutensis*, Gervais.
 — ? *curvidens*, Gervais.
Hyperoodon, sp.
Choneziphius planirostris (Cuvier).
 — *planus* (Owen).
 — *Packardi*, Lankester.
Mesoplodon longirostris (Cuvier).
 — *tenuirostris* (Owen).
 — *gibbus* (Owen).
 — *angustus* (Owen).
 — *angulatus* (Owen).
 — *compressus* (Huxley).
 — *Floweri*, Canham, MS.

SQUALODONTIDÆ.

- Squalodon antwerpiensis*, Van Beneden.

DELPHINIDÆ.

- Orca citoniensis*, Capellini.
Globicephalus uncidens (Lankester).
 Delphinoid, gen. non det.

EXPLANATION OF PLATE II.

- Figs. 1, 1a. *Balæna primigenia*, Van Beneden, var. B. The imperfect right tympanic; from the Red Crag. Museum of Practical Geology.
- 2, 2a. *Balæna primigenia*, Van Beneden, var. D. The imperfect right tympanic; from the Red Crag. British Museum (No. 43399).
- 3, 3a. *Balænoptera definita* (Owen). The imperfect left tympanic; from the Red Crag. Ipswich Museum.
- 4, 4a. *Megaptera affinis* (Van Beneden). The imperfect immature right tympanic; from the Coralline Crag. Museum of Practical Geology.
- 5, 5a. *Megaptera minuta* (Van Beneden). The imperfect left tympanic; from the Coralline Crag. Ipswich Museum.
6. *Hyperoodon*, sp. The right periotic; from the Red Crag. Ipswich Museum.
7. *Choneziphius planirostris* (Cuv.). The left periotic; from the Red Crag. Museum of Practical Geology.
8. *Mesoplodon* (? *longirostris* [Cuv.]). The left periotic; from the Red Crag. Museum of Practical Geology.
9. *Orca citoniensis*, Capellini. The right periotic; from the Red Crag. Museum of Practical Geology.
10. Ditto. A tooth; from the Red Crag. Ipswich Museum.
11. *Globicephalus uncidens* (Lank.). The left periotic; from the Coralline Crag. British Museum (No. 36657).

Figs. 1, 2, 3, one half, figs. 4, 5, two thirds, figs. 6, 7, 8, 9, 10, 11, nat. size. All the tympanics are viewed from the inner and inferior, and the periotics from the tympanic aspect. *a*, anterior articular facet for tympanic; *b*, posterior articular ridge for tympanic; *c*, accessory ossicle, or hollow for the same; *d*, *e*, *f* mark the homology of the ridges and hollows in the different bones; *g*, the capsule containing the semicircular canals.

DISCUSSION.

Mr. NEWTON regretted the absence of Prof. Flower. He had tried to determine some of the specimens himself, and recognized how very difficult a task it was. He complimented Mr. Lydekker on his work. With regard to the fossil Physeteroid teeth, he was under the impression that there was more cement in them than in recent teeth.

Mr. LYDEKKER, in reply, said his remark as to the absence of cement only referred to the type specimen of *Balænodon*.

*



5a.

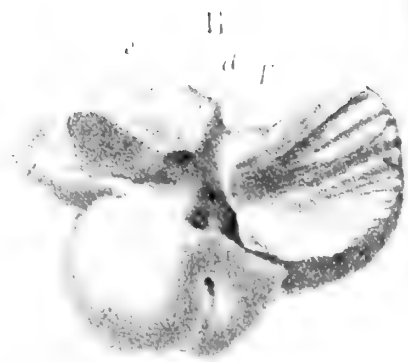

6

9

a

11



9

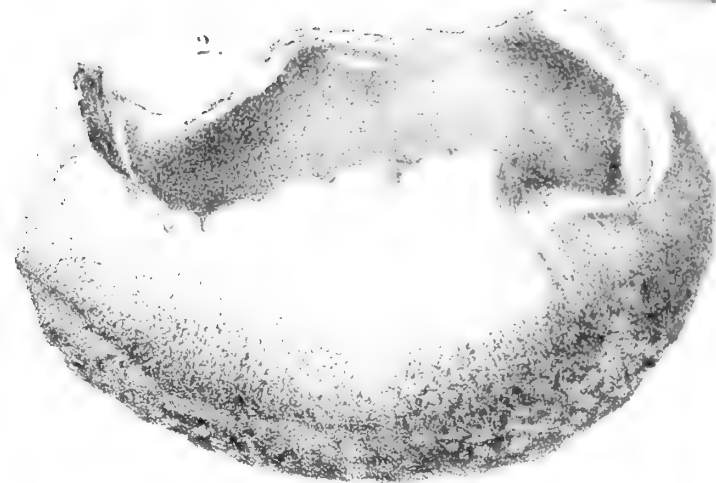

2

10



4a.

21.



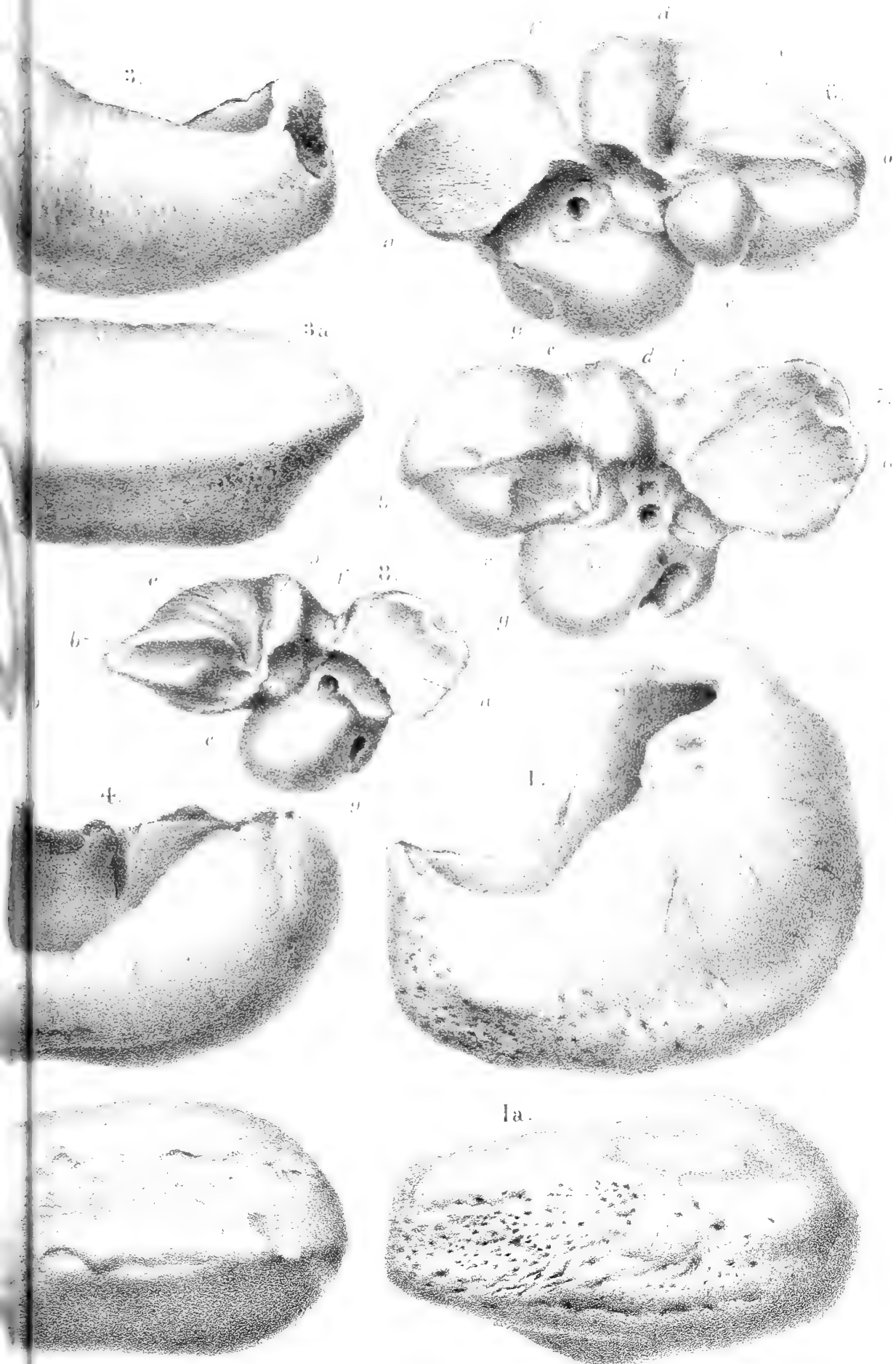



3. *Description of a JAW of HYOTHERIUM, from the PLIOCENE of INDIA.* By R. LYDEKKER, Esq., B.A., F.G.S., &c. (Read November 3, 1886.)

I AM again indebted to Col. J. W. Watson, the Political Resident in Kattiawar, for an interesting addition to our knowledge of the Siwalik fauna of Perim Island, on the western coast of India. The specimen in question (which Col. Watson has presented to the British Museum) is a portion of the left maxilla, with the three true molars, of a species of *Hyotherium*, which is apparently distinct from any named form. The fragment, of which an oral view is given in the accompanying woodcut, has been slightly water-worn, but not to such an extent as to damage it materially; the first molar has the dentine of the summits of the columns exposed by attrition, while the third molar is scarcely affected by such action. The teeth carry

Hyotherium perimense. Part of the left maxilla; from the Siwaliks of Perim Island. (Nat. size.) (British Museum. No. M. 3501.)

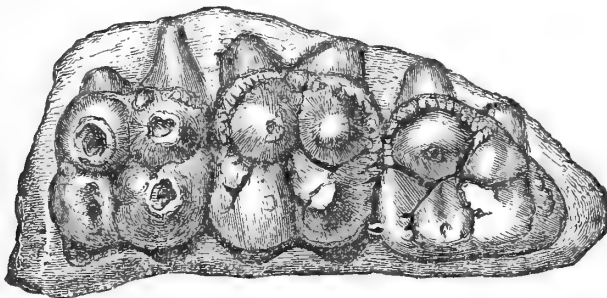

m. 1.

m. 2.

m. 3.

the usual four main columns, with accessory columns on the inner side of the median longitudinal cleft, and have a well-marked and crenulated cingulum on the inner and fore-and-aft surfaces. The crowns of the first and second molars are squared and rather broader than long, while that of the third tooth has its postero-internal angle produced and its outer border sloping towards the median line.

The specimen may without doubt be referred to the genus *Hyotherium*, in the sense in which (following the lead of the late Prof. Peters) I have employed that term in the 'Catalogue of the Fossil Mammalia in the British Museum'*, and we may accordingly proceed to compare it with the named European † and Asiatic

* Part ii. pp. 253-258 (1885).

† A partial synonymy of the more important European species is given in the work cited. It has been subsequently stated by Dr. Max Schlosser that *Chæropotamus steinheimensis*, Fraas, is the same as *H. Sæmmeringi*.

species of that genus, since its distinctness from the American forms may be taken for granted. Before, however, making this comparison, it is necessary to observe that I have already described and figured* a fragment of the mandible of a *Hyotherium* from Perim Island † containing the second true molar, which, from the great relative width of the tooth, I considered might probably indicate a new species. Since the tooth of that specimen agrees precisely in relative size with the corresponding molar of the jaw under consideration, it may be safely regarded as belonging to the same species.

With regard to the European species the present form is distinguished from *H. typum* ‡ (ranging from the Quercy phosphorites to the Middle Miocene of Georgensmünd) not only by its superior size but by the production of the postero-internal angle of the third upper true molar. Confining these comparisons to the larger species like *H. Waterhousei* and *H. Scæmmeringi*, it will be found that the present form agrees with the first-named species § in size, but is distinguished by the relatively wider teeth, the presence of four distinct columns on m. 3, the greater development of the accessory columns, and the absence of an inner cingulum to the upper true molars. With regard to *H. Scæmmeringi* || the upper molars of our specimen are rather smaller than the teeth of that species figured by Peters in the 'Denkschr. k. Ak. Wiss. Wien,' vol. xxix. pl. i. fig. 1, but are otherwise very similar, m. 3 of the Perim jaw agreeing very closely with the specimen represented in fig. 3 of the same plate. The upper teeth appear, however, rather wider than those of *H. Scæmmeringi*, and the lower molar is decidedly wider. This difference, coupled with the improbability of a species which died out in Europe after the Middle Miocene being identical with an Indian Pliocene form, renders it probable that the present form is distinct from *H. Scæmmeringi*, although it is certainly allied.

The only species from India to which a distinct name has been assigned is *H. sindiense* ¶, which occurs in the Lower Siwaliks of Sind. The typical specimens of that species indicate an animal equal in size to the largest race of *H. Scæmmeringi*, and apparently so closely allied that it is very difficult to find any distinctive characters from the cheek-teeth on which the species is founded. With these typical specimens are found other teeth in regard to which it is uncertain whether they belong to small individuals of the same or to a distinct species; the associated lower teeth (which may belong to both the larger and smaller forms) are of a much narrower type than the lower molar from Perim. The type

* 'Palæontologia Indica' (Mem. Geol. Surv. Ind.), ser. 10, vol. iii. p. 97, pl. xii. fig. 5.

† The specimen was reported to be from Perim Island, and its mineral condition indicates that this is certainly correct.

‡ Syn. *H. Meissneri*.

§ See Filhol. 'Ann. Sci. Géol.' vol. xi. art. 1, pl. vi. (1880).

|| Syn. *Palæochærus major*, Pomel.

¶ 'Palæontologia Indica,' *op. cit.* pp. 95-97, pl. xii.

maxilla of the Sind species ('Pal. Ind.' *op. cit.* pl. xii. fig. 6), which contains the last two molars in a much worn condition, belongs to a considerably larger animal than the Perim maxilla, the length of the two teeth of the former being 1.45 against 1.29 in the latter; the talon of m. 3 in the former is also broader and the external cingulum less developed. The smaller Sind upper teeth agree in size with those of the Perim jaw.

If, then, we agree to confine the name *H. sindiense* to the larger Sind form, it would appear that the difference in size would be a specific character in the case of the Perim form; while if, on the other hand, we extend the name *H. sindiense* to all the Sind specimens, the breadth of the lower teeth would likewise point to the specific distinctness of the former.

Provisionally, therefore, regarding the Perim specimens as distinct from *H. sindiense*, the form to which they belong may be named *H. perimense*. This species may be defined as equal in size to *H. Waterhousei*, but distinguished by its wider molars, in which respect it approaches *H. Scemmeringi* and *H. sindiense*, although differing from the former by the greater width of the lower molars, and from the latter either by its inferior size, or by its wider lower molars, or by both these two characters.

Apart, however, from the minor question of specific distinctness, the occurrence of *Hyotherium* in the Siwaliks of Perim Island in association with highly specialized ruminants like *Bramatherium*, *Giraffa*, and Antelopes of modern African types is of very considerable interest, and is one more instance of that remarkable survival in the East of generic forms long after they had passed away from Europe—a circumstance which was, I believe, first brought to notice by Dr. Blanford. In Europe the genus first appeared in the Quercy phosphorites, was exceedingly abundant in the freshwater beds of St. Gérard-le-Puy, and apparently disappeared after the Middle Miocene of Sansan and Steinheim.

In India it was apparently abundant in the Lower Siwaliks of Sind, which are certainly not older than the topmost Miocene, and persisted into the Pliocene of Perim, where, however, it appears to have been very rare. The Siwaliks of Perim appear to be probably intermediate in age between the Lower Siwaliks of Sind and the typical Upper Siwaliks of the Eastern Himalaya, since while they contain several older forms like *Dinotherium* and *Mastodon pandionis* common to the former, they also contain newer types not found in those beds. In the Perim beds *Hyotherium* and *Sus* are found associated, although the latter is very common and the former very rare, this association being paralleled by the occurrence of *Hipparion* and *Equus* in the Eastern Siwaliks.

I will conclude this paper with a few remarks on the affinities of *Hyotherium*. In the first place, the strongly-marked brachyodontism of the genus, the simple structure of the molars, and the circumstance that the last true molar comes into use at a period when the first tooth of the same series is but slightly worn, at once shows the extremely generalized nature of the genus. In structure the true

molars are intermediate between those of *Chœropotamus* and *Sus* — those species in which the molars are widest and there is no talon to m. 3 (*H. typum*) being nearest to the former, while those in which the width of the molars is less and the talon of m. 3 well developed (*H. Waterhousei*) come closer to the latter. In certain examples referred by Dr. Filhol (*op. cit.*) to *H. typum* there is only one external column to pm. 4, which thus shows a retention of a characteristic of *Chœropotamus*. The latter writer has thought that *Hyotherium* should not be regarded as the direct ancestor either of *Sus* or *Dicotyles*; but from the character of its dentition, its wide distribution, its geological horizon, and the absence of any other known form which could occupy such a position, I have long had great doubt as to the correctness of this conclusion, and have expressed myself to the effect that the genus must have been at least closely allied to such ancestral form; and I am now pleased to observe that Dr. Max Schlosser*, of Munich, is of opinion that *Hyotherium* really occupies a middle position between the modern *Sus* and *Dicotyles* and the Upper Eocene (Oligocene) Chœropotamidæ, in the sense in which the latter term is employed by Prof. Flower and myself †. Starting from that family, a line of evolution may be traced in one direction from the type genus to *Anthracotherium*, *Hyopotamus*, and the tetracuspid Selenodonts, while another line may be traced through *Cebochœrus* to *Hyotherium*, *Hippohyus*, *Dicotyles*, *Sus*, and *Phacochoerus*. *Dicotyles* has attained an excessive specialization in respect of the upper premolars (which are as complex as the true molars), while in *Sus* the specialization has been more confined to the true molars; and it is noteworthy that in the specialization of the cheek-dentition of the higher species of the latter genus, while the premolars and first and second true molars only gain a moderate increase in height and complexity, the last true molar becomes enormously developed posteriorly, and does not come into use until the first true molar is almost worn away. This line of specialization culminates in *Phacochoerus*, where all the anterior cheek-teeth may disappear in the adult, and to a certain extent is analogous to the peculiar dental development characteristic of the Proboscidea. Those species of *Sus* which present the greatest specialization in this respect occur in the later Tertiaries of India and North Africa, the common living species (*S. cristatus*) of the former country being probably a descendant of the group which has lost the extreme dental development characteristic of the Pliocene species (*S. Falconeri*) ‡. As examples of species retaining a primitive type of dentition, may be mentioned *Sus andamanensis* of the Andamans, *Sus barbatus* of Borneo, and the River-hogs (*Potamochoerus*) of Africa. At least in the case of the first-mentioned species the retention of a generalized character may be attributed to the absence of competition.

* Morphol. Jahrbuch, vol. xii. pp. 89-92 (1886).

† Dr. Max Schlosser prefers to place *Cebochœrus* in the Suidæ, and to merge *Chœropotamus* in the Anthracotheriida.

‡ For the relations of these species see 'Palæontologica Indica,' ser. 10, vol. iv. pt. 2 (1886).

DISCUSSION.

Dr. BLANFORD described the Island of Perim and the mode of occurrence of the fossils, and showed that the age of the beds was but roughly indicated by their relations to those on the mainland, and was better determined, as had been done by Mr. Lydekker, by the affinities of the fossils with those in the Sind beds, the age of which was accurately demonstrated by marine fossils.

4. *On a NEW GENUS of MADREPORARIA (GLYPHASTRÆA), with REMARKS on the MORPHOLOGY of GLYPHASTRÆA FORBESI, Ed. & H., from the TERTIARIES of MARYLAND, U. S.* By Prof. P. MARTIN DUNCAN, M.B., F.R.S., F.G.S., &c. (Read December 1, 1886.)

[PLATE III.]

MANY years since, the late Dr. S. P. Woodward drew my attention to some very fine specimens of *Septastræa Forbesi*, Ed. & H., in the British Museum, and lately a well-preserved specimen has been sent to me from the Philosophical Institution at Scarborough. There has always been a doubt in my mind regarding the classificatory position of this large branching Tertiary species, and the examination of the specimen lately sent confirms the impression that the species differs so much from the Mesozoic *Septastrææ* that it cannot remain in the same genus, although it must still be placed in the Goniastræoid alliance.

The species mentioned in the 'Histoire Naturelle des Coralliaires' by Milne-Edwards and Jules Haime, described by M. de Fromentel in his 'Introduction à l'étude des Polypiers,' and published by myself in the "Monograph of the British Fossil Corals" (Pal. Soc. Lond.), with one exception, have the axial space nearly or quite open, and the columella is either absent or very rudimentary. But the species named after the late E. Forbes*, I find, has the axial space completely closed, either by united septal ends with some additional tissue, or by a columella, which, by uniting with a number of septal ends and being increased in bulk by a remarkable dissepimental tissue, forms a very projecting central mass in perfect and full-grown calices.

The genus *Septastræa* originated with d'Orbigny in 1849, and the diagnosis he gave was partly reproduced by Milne-Edwards and Jules Haime in 1857†. The species described in the first instance were from the Eocene and Miocene of France and the supposed Miocene of Maryland. A columella is not noticed in the descriptions of any of these types, and it is said, in the generic diagnosis, to be so definitely absent that the want clearly distinguishes *Septastræa* from *Goniastræa*, Ed. & H.

The following was the diagnosis published by Milne-Edwards and Jules Haime from d'Orbigny:—"The corallum is either in the shape of a convex mass or is subdendroid. The calices are polygonal, and their margins are united to those of the neighbouring calices and ordinarily show an extremely delicate line of separation. The septa are large and appear to be formed of perfect laminae, and the endothecal dissepiments are well developed. Columella and pali wanting. Multiplication by fissiparity."

* M.-Ed. & J. H. Ann. des Sci. Nat. 3^e sér. t. xii. p. 164 (1850), and Hist. Nat. des Corall. vol. ii. p. 450. The fossils described were said to be in the collection of the Geological Survey of England and in the Bonn Museum.

† Hist. Nat. des Corall. vol. ii. p. 449.

The genus was placed by M.-Edwards and J. Haime in the family *Astræidæ*, and in a group in which growth took place by means of fissiparity.

The Mesozoic species described by M. de Fromentel and by myself enter the genus thus diagnosed, and the only important modification which I made in revising the genus was to introduce the necessary statement that increase took place by gemmation as well as by fissiparous division of the corallites*. But the genus was included by me in an alliance, the *Goniastræoid*, of several genera, which is characterized by the forms having the corallites united by their walls more or less completely, and without cœnenchyma serial growth not occurring.

A very perfect siliceous specimen of the Maryland species gave the following characters:—

The specimen is generally perfect in its details and once formed a portion of a very large branching colony and was undoubtedly a reef-builder. The fracture across the stem resembles those which occur in large specimens of the genus *Madrepóra* at the present day during violent storms. The outside of the coral is covered with calices in a very perfect condition, and the delicate granular ornamentation of the septa and of the top of a dome of endotheca which fills up the axis and calicular fossa is still to be seen. An excellent natural section of the corallites in the axis of the stem has been the result of fracture. The section shows that the axial or parent corallites have undergone some diminution in the bulk of their walls and septa, and probably this happened during life, for corresponding absorption is seen in many recent forms. On comparing the superficial calices with the sections of their parent axial corallites, very considerable differences will be noticed, and it is evident, after careful examination of this specimen, that had the section alone been present, the description of the details presented by it would not have enabled any palæontologist to give an accurate diagnosis of the species. On the other hand, were the structures seen on examining the superficial calices to be entirely relied on, mistakes regarding the nature of the endothecal structures and of the dimensions of the columella might have been recorded.

The lower endothecal dissepiments are rather stout and horizontal, and are well seen in the axial corallites; and the upper, which are numerous and close near the calices, form perfect oblique or domed floors between the septa, so as to shut out the interseptal loculi beneath them from the surface. These uppermost dissepiments come up to about the same level at the bottom of the calice, and reach up to within a fractional part of a millimetre from the free edges of the septa and columella (Pl. III. fig. 7). Hence the septa seem to rest upon the upper combined dissepiments and to resemble fine linear growths; two long ones are often, but not invariably, continuous with the columella and reach across the calice, apparently, but not truly, as one long septum. The study of the section of a

* "Revision of the Families and Genera of Madreporaria," Journ. Linn. Soc., Zool. vol. xviii. 1884, p. 103.

stem explains these appearances, and it is seen that the septa are really high near the axis, and narrow, and that although some unite with others at the axial space of a corallite, there are generally traces, and usually very definite proofs, of the presence of a trabecular and non-essential columella, it often being reduced to a mere lamina which is in the path of two opposed large primaries. The structures at the bottom of the calices resemble a solid mass, and might be taken to be very large columellæ not very unlike those seen in some rugose corals such as *Clisiophyllum* and *Lonsdalia*; but the true conception of the structures may be obtained by studying the section of the stem and some of the newer calices at the tops of the ramuscles of the upper part of the colony. The theca or wall of one corallite is in contact with those of its neighbours; but fusion only occurred here and there, and, indeed, in one place there are traces of very slightly projecting costæ to be seen running down the outer part of the walls. The union is so decided that the corallites are, and always were, inseparable, and the position of junction is traced by broken lines in the natural transverse section of the axial corallites and by the geometrical grooves at the surface of the colony.

Gemmation is seen on the united walls of corallites, and the buds have six septa; it is also observed, in the natural transverse section produced by the fracture of the stem (fig. 2, *d*), on the surface of the colony amongst the largest calices and also amongst the more rapidly grown calices at the extremity of the stunted branches. Fissiparity is exceptional, but occurs.

The crossing of the calices, so generally but not universally, by what appears to be a long thin septum, which consists of two opposite primaries united at the axis, with or without a columella, is very striking in appearance, and it is difficult to understand how it or the filling-up of the axial spaces could have escaped the notice of Milne-Edwards and Jules Haime; for the structures are perfectly evident in their type, which is now in the British Museum. The granulation of the edges of the septa and columella and even of the top of the dissepiments is most distinct and is as characteristic as the linear grooves which separate, in such a geometrical manner, adjacent calices.

The colonies of this species attained a considerable size, and their shape was very variable. The type of Milne-Edwards and Jules Haime, now in the national collection in the British Museum, is as large as a man's hand and wrist, has a more or less cylindrical lower stem, which enlarges upwards, and is, as it were, compressed, the surface being irregularly swollen in places and smooth elsewhere. There are terminal, subramose, blunt-ended branchlets, and gibbosities resembling nascent branches. In another colony the shape is nearly cylindrical, and there are ill-defined gibbous swellings on it; the size is less than that of the other. A third specimen in the British Museum is a part of a very large colony which has lost its branchlets and much of its main mass. The shape is like that of a thick slice of bread, tall, narrow, and wide. Two of the surfaces are large and broad and nearly flat, and a third or edge-surface

is long and narrow, and marked by the roots of several branchlets which have been fractured from the main mass, their axial corallites being seen in transverse section. The height is 140 millim.; the breadth is rather greater than the height; and the thickness is from 34 to 52 millim.

In Milne-Edwards and Jules Haime's rendering of d'Orbigny's generic definition of *Septastræa* the words "multiplication by fissiparity?" occur. The note of interrogation is not repeated in their own description of the genus in the 'Histoire Naturelle des Coralliaires.' Fissiparity occurs evidently enough in the Mesozoic species without a columella and with an open axial space. It is a fact, however, that there is not a single instance of progressing fission in any calice of the type described by the French authors, which is in the British Museum. There are no calices with a figure-of-eight shape, and in none are there small and new septa starting from the sides of the long septum-like structure which crosses the perfect and full-grown calices. It is quite a mistake to state that this striking feature has to do with fissiparity. In the specimen belonging to the Scarborough Philosophical Society's Museum there is some crowding of the calices at the base of one of the branchlets, and the intercorallite walls there are thin; there is no superficial groove, and the appearance of the septa resembles that of some recent types which are undergoing fissiparity and in which the division is accompanied by very rapid growth (Pl. III. fig. 3). But it is nevertheless true that these appearances may be the result of irregular corallite-growth under the influence of pressure from crowding.

The instances of fissiparity are exceptional; but the process existed, for there is a fair example in the fractured surface of the stem of the specimen first examined (fig. 2), but not in Milne-Edwards's type; and there is a very remarkable and suggestive instance in the smallest of the specimens in the British Museum (figs. 4 and 4'). A section was cut at a slight depth, parallel with the surface, so that sections of corallites were made at a little distance from the calices above. It was evident, on counting the calices and the sectioned corallites, that the former were more numerous than the others, and the reason was because one of the sectioned corallites was divided by fission (fig. 4). The commencement of the process can be traced, and a nipping-in is to be seen with considerable confusion of the septa. The long lamina crosses the corallite at right angles to the commencing fission, and that is not what would have been seen had it been a factor in the process. On examining the free surface of the colony corresponding to the sectioned corallite, two calices are noted which have an incomplete wall between them; moreover a septum will be observed passing from one calice to the other (fig. 4'). These calices are separated from their neighbours by well-developed walls. It appears that the growth of the dividing corallite was rapid.

The number of the calices with the long lamina (that is to say, perfect calices) varies in different parts of the colony; and if square patches are separated and the number of calices of all kinds on them

be counted, it will be found that in some with 55 calices 35 have the long lamina and 10 have an indistinct septal arrangement, while the rest have no long structure crossing the calicular fossa. In a patch with 75 calices of many shapes and sizes there are 55 with the elongate structure. The orientation of the lamina differs even in neighbouring calices.

The septa are bilamellar, and the evidence of a very irregular and narrow interlamellar space is apparent, sometimes superficially, and invariably in microscopic sections of corallites near the calices.

A perfect, full-grown calice has the two opposite primary septa united at the axis by means of a narrow discontinuous columella, which is ornamented in the same manner as the septa, but which, in some instances, has a raised edge (figs. 3, 6, 9, and 10), or they may unite by their inner ends and close partly the axial space with or without the assistance of thickening or of any extra growth (figs. 12, 13, and 14). In buds the columella may be distinct, and there are the usual six primaries (fig. 2, *d*). In large immature calices the six primary septa may converge and unite with a small columella or, what appears to be the more common case, they do not unite. The ends elongate or twist (fig. 16) and, with the dissepimental tissue, close the axial space. It is this closure, either by a columella which sections prove to be occasionally discontinuous and always non-essential in its method of growth, or by united septal ends, or by twisting and elongation of the septal ends, assisted by the tabula-like upper dissepimental structures, that forms the main distinction between the new genus and *Septastræa*.

The endotheca is variable in amount, and whilst it is close and thin in some corallites, or parts of corallites, it is distant and stout in others. In some cases the horizontal stout platforms are fairly regular; but, as a rule, although the dissepiments completely close the interseptal loculi and act as tabulæ, they lack the regularity of those endothecal structures. Thin dissepiments often close the whole of the interseptal loculi at indefinitely placed intervals in the height of the corallites, and as completely as any tabulæ (fig. 6). The uppermost dissepiments are those which close in the calicular fossa and reach up close to the free edge of the septa. There are no deep interseptal spaces in the form, and the dissepiments moreover come close to the top of the axis, and, by joining with the septal ends and the intermediate structure (when it exists), help to close the axial space and to form a columella. The upper surface of the dissepiments at the bottom of the calices is ornamented with sparsely placed granules, and this very exceptional ornamentation is not seen on the lower dissepiments, having been absorbed during growth. The dissepiments are often very close near to the calices, and the visible one at the bottom of the fossa is close above several others, which seem to have followed the same lines of curvature. It is this festooning of the dissepiments which, when seen in a vertical section of the colony, adds to the old-fashioned appearance of the more or less tumid mass at the base of the calicular fossa (figs. 7 and 8). Probably it was the very tabulate appearance of the endotheca of

the fossil which Lonsdale examined that induced him to name it *Columnaria*, and the intercalicular groove doubtless intensified the importance of the internal arrangement in his mind. *Septastræa* has no such dissepimental structures.

The necessity of introducing a new genus is obvious, for the presence of the structures closing the axial space, and the characters of the dissepiments near and at the bottom of the calice, are of great physiological importance. In *Septastræa* proper the mesenteries would have had abundance of support on the sides of the septa, and the visceral cavity would have been prolonged into the axial space; but in the form under consideration there is barely any room for interseptal structures, and the nodule in the axial space would limit the downward extension of the visceral cavity. It is very interesting to notice a columellar structure in this Tertiary reef-builder which is somewhat similar to the axial arrangement in *Lonsdalia* and *Clisio-phyllum*. But the laminate columellæ of those Palæozoic forms are essential and largely developed, and those of the new form are comparatively insignificant; but there is the same crowding of dissepiments close to the axial space and the same apparent extension of a long primary septum.

The following is the diagnosis of the new genus:---

Section MADREPORARIA APOROSA.

Family ASTRÆIDÆ; alliance *Goniastræoidea*.

Genus GLYPHASTRÆA, gen. nov.

Colony large, subramose; corallites prismatic, more or less perfectly united by their walls and having a discontinuous line of separation between them; calices polygonal and shallow, having polygonal linear grooves between them, and the axial space closed; septa unequal, minutely serrate or granulate at the free edge, some narrow within and long; columella small, parietal, lamellar, or ribbon-shaped, uniting opposite primaries, or several septa sometimes absent, and then primary septa unite at the axial space; endotheca well developed, often simulating tabulæ; dissepiments near the calice extending upwards close to the free edges of the septa and columella, closing the interseptal loculi and forming with the septa and columella a dome-shaped mass which projects and fills up the bottom of the calicular fossa; pali absent; increased by gemmation from the walls between the calices, and rarely by fissiparity.

GLYPHASTRÆA FORBESI, Ed. & H., sp.; amended.

Colony large, with a stout stem terminating in gibbous prominences, resembling aborted branchlets; calices numerous, crowded, irregular in size and shape, hexagonal, pentagonal, and even square in outline, shallow, with broad flattish margins separated by straight linear shallow grooves, which form polygonal shapes around each calice; septa broad at the margin, reaching the linear groove, subequal at the wall and granular there. There are three perfect cycles of septa

and, rarely, some members of a fourth. In the first instance the primaries and secondaries reach the axis, and the tertiaries do not project much from the wall. Commonly, in full-grown calices, two long slender opposite primaries unite with the columella so as to cross the calice, having the appearance of one very long septum; in other calices the columella unites several septal ends, and the appearance just noticed does not occur; or opposite primaries may unite without a columella. The inner parts of the septa are slender, often wavy, and their granular free part is very low, on account of the occurrence of dissepiments; upper dissepiments free and granular, uniting with the septa and columella to form a convex mass at the bottom of the calice.

Fissiparity rare, and when gemmation occurs the buds have six primaries; height many inches; breadth of the stem 28 to 32 or more millim.; breadth of calices from 1.5 to 6 millim.; depth 1.5 to 3 millim.

Locality. Maryland Tertiary deposits.

The only notice which I can find in any American publication of *Septastræa Forbesi*, Ed. & H., now *Glyphastræa Forbesi*, Ed. & H., sp., is in the "Check-list of the Invertebrate Fossils of North America," by Meek, Smithsonian Miscellaneous Coll. vol. viii. 1884, "Tert. Syst. Miocene Epoch." But there is nothing more than the name and the locality of Maryland mentioned. The form does not appear to have been figured anywhere.

Lyell was the first geologist who introduced the corals of Virginia and Maryland to the notice of science, and Lonsdale studied the forms. Lyell's communication is in the fourth volume of the Proceedings of this Society, p. 547 (1845), and Quart. Journ. Geol. Soc. vol. i. 1845, p. 413. Amongst other corals Lyell collected from Virginia a compound, ramose, cylindrical, lobed or massive and expanded species, which Lonsdale, in a paper in the same volume (p. 497), described as *Columnaria* (?) *sexradiata*. He figured the form and gave a magnified view of a calice.

I do not think that Edwards and Haime had the opportunity of studying Lonsdale's type, otherwise they would not have placed it in such a remote genus as *Astrangia*. It appears, after studying Lonsdale's careful description, that Meek is correct in placing the so-called *Columnaria* in the genus *Septastræa*, as understood by Milne-Edwards and his school, although Lonsdale stated that he could not find proofs of fissiparity on the surface of the corallum. The magnified view of the calice given by Lonsdale shows a small columella and the stout parts of the primary and secondary septa near the margin; moreover he figures and mentions a groove which bounds the calices; but there is union shown between some of the tertiary septa and the secondaries which does not occur in the calices of the other species. Moreover the open condition of the interseptal spaces of the immature calices of Lonsdale's species is not seen in *G. Forbesi*; nevertheless the alliance of the species is very close. It appears to me that Lonsdale's species must stand as *Glyphastræa sexradiata*, Lonsd., sp. The type of Lonsdale's species is not in the



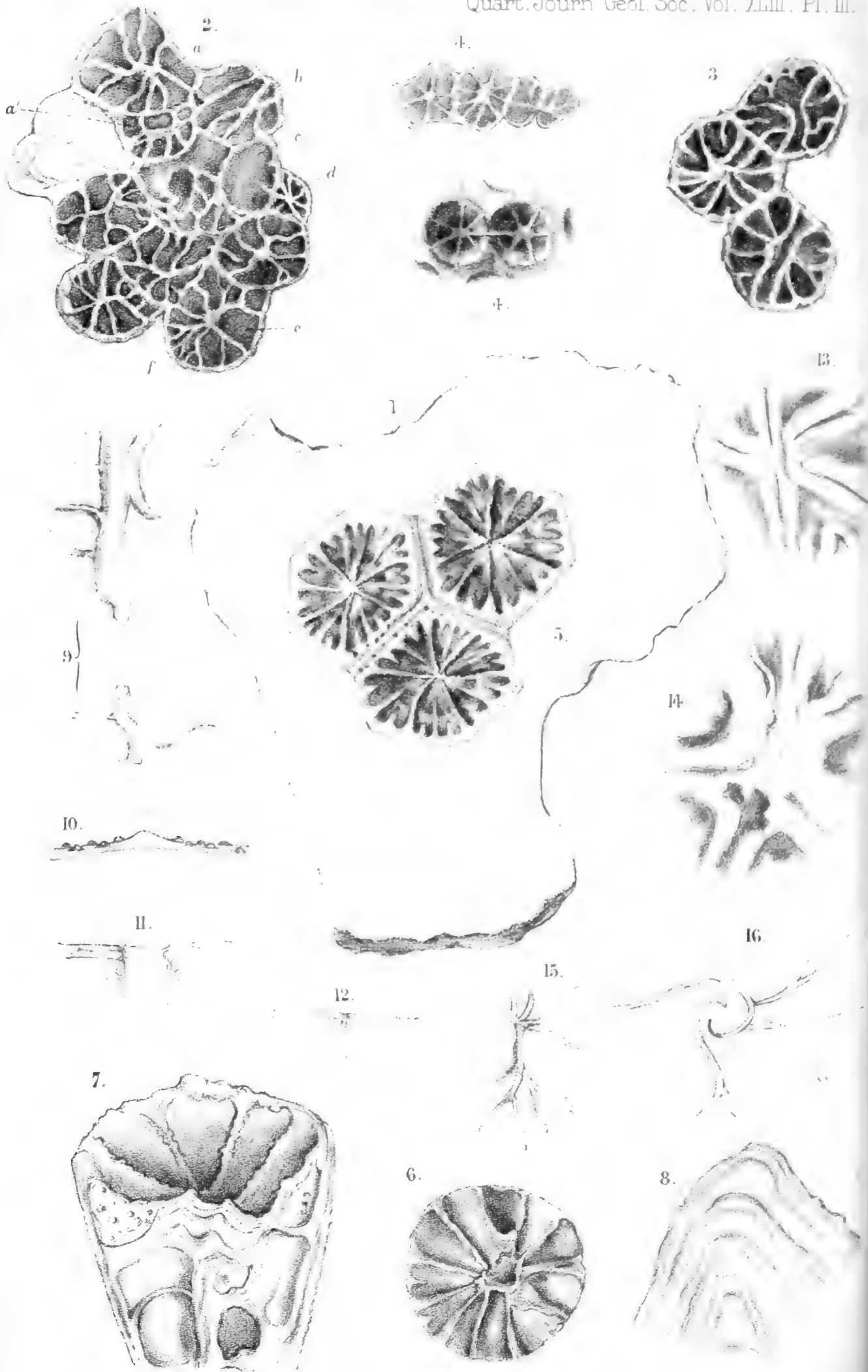

A. S. Foord. ad nat. del. et lith.

Mintern Bros. imp.

GLYPHASTRÆA FORBESI.

collection of the Geological Society. There is, however, a much weathered specimen of *Septastræa Forbesi*, Ed. & H., = *Glyphastræa Forbesi*, with the name of Dr. Koch upon the tablet as that of the collector. The specimen is a very instructive one, and it shows how weathering may destroy all those structures which characterize a species. There is only one calice in the rather large colony which indicates that there was once a small columella, and the intercalicular groove is almost destroyed in every part of the coral. The edges of the neighbouring corallites are often sharp from removal of the inside of the calices. The study of this specimen proves how thoroughly palæontologists may be deceived by describing indifferent specimens.

EXPLANATION OF PLATE III.

Fig. 1. The colony of *Glyphastræa Forbesi*, in outline; nat. size.

2. Part of the fractured stem, magnified. *a*, corallite undergoing fissiparity; *a'*, a part dividing from *a*; *b*, corallite undergoing fission; *c*, corallite with a confused septal arrangement; *d*, a bud with six primaries, a secondary septum, and a columella; *e*, corallite showing a columella; *f*, corallite commencing fission (compare the part nearest the axis of the stem with *a'*, in which the process has been completed).
3. Three weathered corallites, magnified, taken close below the position of the calices; fission in progress in two, and the columella visible in the third.
4. Sections of corallites, one undergoing fission, magnified. Specimen in the British Museum.
- 4'. Two calices corresponding to the fissiparous corallite of fig. 4, magnified.
5. Some calices, magnified.
6. Section of a corallite showing complete endotheca and a ring-shaped columella, magnified. Specimen in the British Museum.
7. Longitudinal section of a corallite showing close successive endothecal dissepiments below that which closes the calice inferiorly, magnified. British Museum specimen.
8. A similar section showing successive layers of endotheca in relation to a columella, magnified. British Museum specimen.
9. Part of a longitudinal section of a corallite showing a discontinuous columella, magnified. British Museum.
10. The central superficial nodule of a columella, magnified. British Museum.
11. The position of the ribbon-shaped part of the columella, placed between the inner ends of two opposite primary septa, magnified; more or less diagrammatic.
12. Primary septa joining at their inner ends, magnified; diagram.
- 13, 14. Junction of septa accompanied by more or less columellar structure in 14; a section magnified. Specimen in British Museum.
15. View of septa and columella from above, magnified. British Museum.
16. Twisted septal ends forming a false columella, magnified.

DISCUSSION.

Dr. HINDE remarked on the interest attaching to the specimens. He inquired if one of the specimens on the table belonging to the Society was not the type of M.-Edwards and Haime. He thought the prolongation of the septa across the calice indicated merely a tendency to fissiparity, and was not a generic character. He was not sure if there was a columella distinct from this prolongation,

which was only well seen in a few calices. He asked if a section of the coral had been made, as this would show whether there is really a columella or not.

Mr. ETHERIDGE said there ~~had been~~ ^{were} several specimens of *Septastræa Forbesi* at the British Museum, and they were identical with those on the table. The septa are waved, and they anastomose more than was shown by Dr. Duncan's figures. The speaker then proceeded to point out some of the other minute characters of the genus *Septastræa*, and especially showed that the junction of the septa at the commencement of fissiparity was very difficult to recognize, but, if seen, was unmistakable.

Dr. DUNCAN, in reply, said the type of M.-Edwards and Haime had been in the Museum of the Geological Survey, and had been sent to the British Museum, consequently he could not lay it on the table. He showed that there was a distinction to be made between the columella and any prolongation of the septa at the commencement of fissiparity, and that this could be recognized in the fractured part of the specimen.

5. *On the OCCURRENCE of SPECIES of the GENUS DIPHYPHYLLUM, Lonsdale, in the LOWER CARBONIFEROUS STRATA of SCOTLAND, with a DESCRIPTION of some NEW SPECIES and NOTICES of VARIETIES.* By JAMES THOMSON, Esq., F.G.S., &c. (Read March 24, 1886.)

[PLATES IV. & V.]

(Abridged.)

THE object of this communication is to offer evidence in favour of the recognition of the genus *Diphyphyllum*, which was defined many years since by Lonsdale, and which has not been definitely accepted by any palæontologist, with the exception of M'Coy. It is proposed to give a slight history of the genus and species, and then to notify the occurrence of all the species with varieties in somewhat remarkable deposits in the Lower Carboniferous series of Scotland, and to describe two new species and a variety of one of them.

The facts now brought forward clearly prove the truth of Lonsdale's diagnosis of the genus, which enters the family Cyathophyllidæ of the Rugosa, and also necessitate the introduction into the generic diagnosis of the words "increase by gemmation and by fissiparity."

The genus *Diphyphyllum* was defined by Lonsdale in Murchison, Keyserling, and De Verneuil's 'Geology of Russia and the Urals' (appendix, p. 622), and the type of the species *D. concinnum*, Lonsd., is in the collection of the Geological Society of London. The definition was as follows:—"A stony lamelliferous polypidom; lamellæ exceeding 12, biplated; branched, branches dichotomous; internal structure, triareal—1, central area intersected by flat, convex, or irregular diaphragms, no persistent axis; 2, intermediate area traversed vertically by lamellæ, interspaces crossed obliquely or downwards by extensions of the diaphragms and subordinate plates; 3, outer area traversed by lateral extensions of lamellæ, interspaces crossed by arched or vesicular laminae inclined upwards and outwards; stems not uniformly thickened by external secretions, but occasionally united when in juxtaposition." In explanation Lonsdale notices that acicular points arise from the upper surface of the diaphragms (tabulæ), and sometimes are continuous through the diaphragms above for a short distance, but there is no persistence of this structure so as to form a columella. The corallites are in ramified masses.

Diphyphyllum concinnum, Lonsd., is defined as follows in the above-mentioned work, p. 624, pl. A. fig. 4:—"Stems cylindrical, nearly smooth; crossed externally by close, fine, waved lines, and stronger, unequal, distant bands; lamellæ numerous, variable; inner surface of plates furrowed strongly upwards and outwards; central area, diaphragms flat, convex or irregular; intermediate area, principal lamellæ exceeding 30, more or less waved; intermediate very unequal; interstitial prolongations of diaphragms inclined sharply downwards, accessory plates nearly horizontal; outer area, lamellæ

variable in strength and range, interstitial plates largely vesicular : terminal cup deep, lined by edges of the lamellæ, no central boss." Relative proportions of areas not constant. Diameter of corallites 4 to 4.5 lines.

Localities. Carboniferous limestone, Kamensk, Siberian side of the Oural, and Bristol, England.

M'Coy found species of the genus and recognized the increase by fission or fissiparity ; he published his definitions in *Ann. & Mag. Nat. Hist.* ser. 2, vol. iii., and subsequently in his 'Palæozoic Fossils of Great Britain,' p. 88 (1855). *Diphyphyllum latiseptatum* and *D. gracile* were there added to the English coral-fauna.

M'Coy notices how rare dichotomous branching is amongst the Cyathophyllidæ, and that this form of increase distinguishes *Diphyphyllum* from *Cyathophyllum*. He states that there is no axis, and that the corallites are biareal, the large central area being occupied by a strong simple transverse diaphragm, deflected at the circumference, surrounded by a narrow, outer vesicular area. Outer wall thick, radiating lamellæ numerous, not reaching the centre. In *D. latiseptatum* there are 28 primary septa and 28 smaller ones ; *D. gracile*, which is a small form, has not one half the septal number of the other species. There is no doubt that M'Coy thoroughly understood Lonsdale's definition, and that his own specific diagnoses are correct.

From the time when M'Coy wrote, down to the present day, nothing but doubt and denial have been associated with the genus so well distinguished by Lonsdale. Milne-Edwards and Jules Haime (*Hist. Nat. des Corall.* vol. iii. p. 434, 1860), considered Lonsdale's species to be the same as M'Coy's *D. latiseptatum*, and that the genus was founded upon specimens of *Lithostrotion* in which the axis had been lost. They do not mention the fissiparous increase of the corallites at all. Prof. Hall (*Pal. New York*, vol. ii. p. 113) describes *Diplophyllum* and separates it from *Diphyphyllum*, recognizing the affinities of the genera.

Billings (*Canadian Journ.*, March 1859) debated the fissiparous method of increase in Lonsdale's genus, and yet separated it from *Lithostrotion* on account of the defective axial structures. He, moreover, considered Hall's genus to be synonymous with Lonsdale's, which it is not.

De Koninck gives an excellent history of the genus in his *Rech. sur les Anim. foss. du Terr. Carb. de la Belg.* pt. 1, p. 33 (1874). He shows how Lonsdale separated the genus from *Lithostrotion* on account of the absence of a columella, and criticizes Milne-Edwards and Jules Haime. He does not, however, admit that fissiparity occurs, and maintains that the appearance is due to the rapid coalescence of young individuals which have been really produced by gemmation. He agrees in this respect with M. Ludwig (*Zur Pal. des Ourals*, p. 14, pl. ii. figs. 4, 5, 7). De Koninck, however, considers that Milne-Edwards and Jules Haime have admitted the fissiparity, as did, of course, M'Coy. He reflects upon the mistakes of D'Orbigny and De Fromentel in using the generic name given by Lonsdale for very

different corals from those to which he intended to apply it, namely the fasciculate Lithostrontionts. Nevertheless, M. de Koninck's reading of Lonsdale's definition of *Diphyphyllum* (*op. cit.* p. 33) does not satisfy those who believe in the fissiparity of the individuals of its species. This is to be regretted, because it is now shown by the Scottish specimens that Lonsdale was correct; and, moreover, in order to complicate matters, there are also forms in the Scottish Carboniferous which agree with De Koninck's insufficient generic diagnosis, and which may be termed Lonsdale's *Diphyphylla*, increasing by gemmation only, and with more or less united corallites (see the concluding sentence of this communication).

The specimen of *Diphyphyllum concinnum*, Lonsd., figured by De Koninck does not show fissiparity; but similar slabs are to be obtained in the Scottish Lower Carboniferous, and fissiparity is seen now and then in them, the greater part of the increase being due to gemmation. De Koninck also considers M'Coy's *D. latiseptatum* to be synonymous with *D. concinnum*, the difference being due to vigorous growth of the first-named coral.

Lindström, in his useful index to the generic names of the corals of Palæozoic formations (Bihang till k. Svenska Vet.-Akad. Handl. Bd. 8, no. 9, 1883), states that *Diphyphyllum*, Lonsdale, 1845, has *Eridophyllum*, Ed. & H., as a synonym. This is an error, for *Eridophyllum* differs very decidedly; it does not increase by fissiparity and has rootlets.

The presence of several forms which must come within the genus *Diphyphyllum*, Lonsd., in the Lower Carboniferous strata of Scotland is placed beyond a doubt, and the difficulty is to distinguish species from varieties. Certainly there are four groups of species and some varieties which have been collected, and they may be divided as follows:—

1. The *D. concinnum* group, with numerous primary and smaller septa, not less than from 45 to 60 in number; endotheca moderate.

2. Large forms with long and shorter septa, about 40 in number; endotheca in two distinct circles. A new species, *D. cylindricum*, comes in here, with a second, *D. Blackwoodi*.

3. Large forms with numerous septa and much endotheca, filling largely the interseptal loculi. Here come in *D. latiseptatum*, M'Coy, and two varieties, var. *giganteum* and var. *interruptum*.

4. Small forms with small corallites with few septa: *D. gracile*, M'Coy.

The following old and new species and varieties of the genus *Diphyphyllum*, Lonsd., occur in the Lower Carboniferous of Scotland:—

DIPHYPHYLLUM CONCINNUM, Lonsd. (Pl. IV. fig. 1.)

A variety with smaller corallites than the type, and about 44 septa; diameter 6 millim. by 8 millim., in the instance of the largest corallites. The distribution of the endotheca, tabulæ, and acicular points is as in the type, and everything is on a smaller scale. The corallites are tall and wide apart. Gemmation appears to be more frequent

than fissiparity, and this may occur so that the parent corallite becomes trilobed in transverse outline, and the fission is double instead of single. That this is not a junction of buds can be proved by studying the growth of the septa from the dividing laminae.

Locality. Lower Carboniferous, Scotland. Kirtle Bridge and Blackridge, Dumfries.

Var. *FURCATUM* (Pl. IV. fig. 2). This variety has slightly smaller septa and wider central space than the type. It does not occur in dense masses.

Locality. Near Fenwick, Ayrshire and Corrieburn, Dumbarton.

DIPHYPHYLLUM BLACKWOODI, sp. nov. (Pl. IV. fig. 3.)

The corallum is in dense fasciculate masses, with corallites of different sizes, cylindrical, tortuous, close or not, rarely in lateral contact. Epitheca delicate. Diameter 4 to 6 millim. Fossula with a small primary, often indistinct. Septa 15 to 20, according to the size of the corallite, with a similar number of smaller ones (30 to 40 in all), the larger extending inwards considerably, but leaving a wide central space; they are very thin and delicate near the equally thin wall, and are stouter and decidedly bilaminate at their junction with the innermost endothecal ring; they may extend beyond that. The smaller septa are short, thin near the wall and thicker near the outer endothecal ring. Acicular points rarely exist—in one corallite out of 14. Endotheca stout between the septa and vesicular; the inner circle of it is often festooned. A vesicular structure is often seen near the wall in the interseptal loculi. Tabulae large, horizontal in the central area and inclined at the edges towards the underlying tabula; sometimes bent upwards and then having a relation to the fissiparity, which is both single and double.

Localities. Auchenmead, Beith, near Fenwick, Ayrshire; Boghead, Lesmahagow, Lanarkshire.

Var. *APPROXIMATUM*. (Pl. IV. fig. 4.)

This has the "rods" very frequently developed.

Locality. Boghead, Lesmahagow, Lanarkshire.

In a coral with closer corallites than the last, and which might almost be considered to be a variety of it, the septa of the principal series extend so far inwards, and the endotheca is so much less like internal walls, that I consider it to form a new species:—

DIPHYPHYLLUM CYLINDRICUM, sp. nov. (Pl. IV. figs. 5, 5 A.)

Corallum in dense fasciculate masses, corallites tall and cylindrical, epitheca thin, with narrow growth-rings. Septa few, 18 to 20 large and as many small, the large passing far in and reducing the dimensions of the central area and tabulae. The small septa extend about one fourth of the distance of the others. The vesicular endotheca is delicate, in two fairly distinct circles in the interloculi, and some delicate inclined stereoplasm occurs. Fissiparity is frequent and is of both kinds; gemmation also occurs.

Locality. Boghead, Lesmahago; Roughwood and Thirdpart, Beith, Ayrshire.

DIPHYPHYLLUM LATISEPTATUM, M'Coy. (Pl. V. fig. 6.)

This form must now be separated from *D. concinnum*, for the specimens show a large corallite with 52 septa in all, longer primary septa than in *D. concinnum*, and a very considerable vesicular endotheca filling the interseptal loculi, and much more of it than in the species determined by Lonsdale. Both kinds of fissiparity are present.

Localities. Corrieburn, Dumbarton, and Fenwick, Ayrshire.

There are two varieties of this species, var. *giganteum* (Pl. V. figs. 7 and 8) and var. *interruptum* (Pl. V. fig. 9).

DIPHYPHYLLUM GRACILE, M'Coy. (Pl. V. fig. 10.)

This is the smallest species of the genus, and the Scottish specimens are fairly undistinguishable from the type. The septal number is small, and there is fissiparity as well as gemmation to be observed in the method of increase of the individuals. The corallites are in tortuous, ascending, and irregular bifurcating masses.

Localities. Cotcastle near Strathaven; Braidwood and Brockley, Lesmahagow; Roughwood and Cunningham, Bedland Dalry, Ayrshire.

List of Scottish Lower Carboniferous Species and Varieties of Diphyphyllum, Lonsd.

1. *Diphyphyllum concinnum*, Lonsd., variety.
var. *furcatum*.
2. " *Blackwoodi*, sp. nov., and var. *approximatum*.
3. " *cylindricum*, sp. nov.
4. " *latiseptatum*, M'Coy, and vars. *giganteum* and *interruptum*.
5. " *gracile*, M'Coy.

Some of these forms are found in large masses and environed and covered by volcanic ash. It is not too much to believe that some of the variability of the species may have been produced by the rather frequent slight changes of external conditions which must have accompanied the vulcanicity of the Lower Carboniferous age. Indeed, the volcanic ejectamenta appear to have finally destroyed the life of the individuals over the area, for the species are not found in a higher geological horizon.

The examination of the numerous species and varieties of the genus established by Lonsdale enables the truth of his description and diagnosis to be appreciated. His only mistake was an omission; for when he stated that the species increased fissiparously, he did not also state, what has been shown here, that gemmation also occurs. The description given of the tabulæ by Lonsdale is correct, and so is that of the acicular points sometimes becoming rods which do not extend for any great height in the centre of the corallum. These

points rise from the surface of a tabula, and when there are rods they transfix, as it were, several tabulæ. The rods are rarely seen, but, by searching, some will be found in a somewhat definite percentage of corallites. The triareal nature of the corallites is to be recognized, but it is a term which has become disused, especially as the endotheca only gives characters of second-rate importance as a rule.

The fissiparity is much better shown in the specimens herein described than it was in those seen by Lonsdale, and there are three kinds of the process. In some corallites bending in and figure of 8 occurs, as in the Mesozoic and Recent Corals, and division took place at the narrowing. But usually a ridge grows across the corallite, and septa are formed on either side, and then the ridge, which, for a time, has been partly the wall, separates into two portions. The third method is singular, for two ridges grow towards the centre of a corallite, and one reaches the other at right angles near the axis, and thus the appearance of a trilobed budding is presented; but it is evident that septa only grow from the ridges, and that would not be the case in buds. After separating, the new corallites grew upwards away from one another. The ridges, which have so much to do with the two commonest kinds of fissiparity, are the extension inwards of oppositely placed large septa; the inner ends unite and shut off the two parts of the corallite, and septa grow from the faces looking towards the new central areas. In another form it appears as if a tabula turned up or grew up at its outer edge and stretched across the corallite at the calice; it came up to the bottom of the visceral cavity, and then septa grew from both sides of it and fission occurred.

Fissiparous growth is a very rare phenomenon amongst the Rugose Corals, and, so far as is known, *Diphyphyllum* is the only genus in which it occurs. The alliances of the genus need hardly be noticed here, as they have been discussed by Milne-Edwards and Jules Haime, and especially by De Koninck in the work already quoted.

The presence in Scotland of a species of a genus which would come within that which should receive De Koninck's *D. concinnum* (non Lonsdale) has been discovered of late, and it necessitates the re-definition and renaming of the Belgian type, so as to separate it from the fissiparous form. This new genus will form the subject of a future communication.

EXPLANATION OF PLATES IV. & V.

PLATE IV.

- Fig. 1. *Diphyphyllum concinnum*, Lonsd., transverse section showing fissiparity.
 2. ———, var. *furcatum*.
 3. ——— *Blackwoodi*, Thoms., transverse section.
 4. ———, var. *approximatum*, transverse section.
 5. ——— *cylindricum*, Thoms., transverse section; 5 A, longitudinal section of corallites.

1

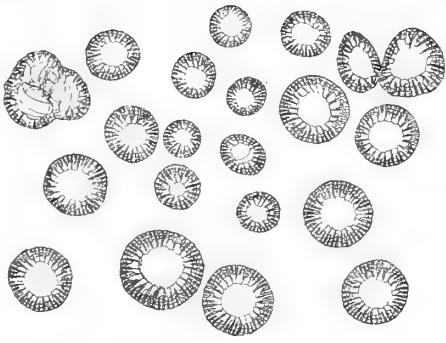

2

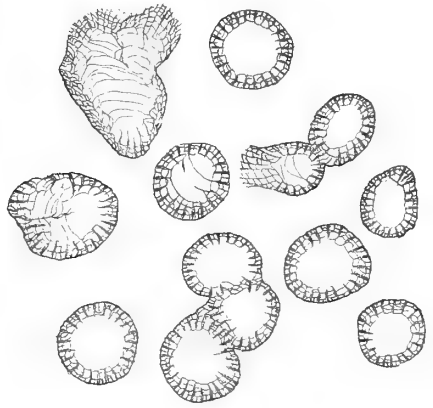

3

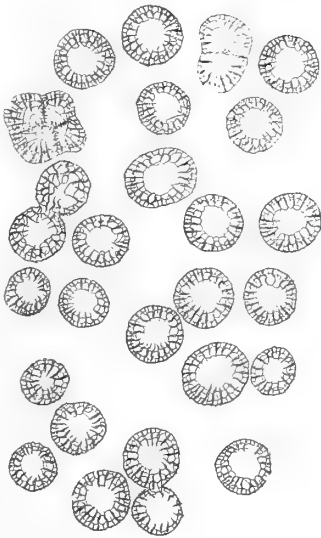

4

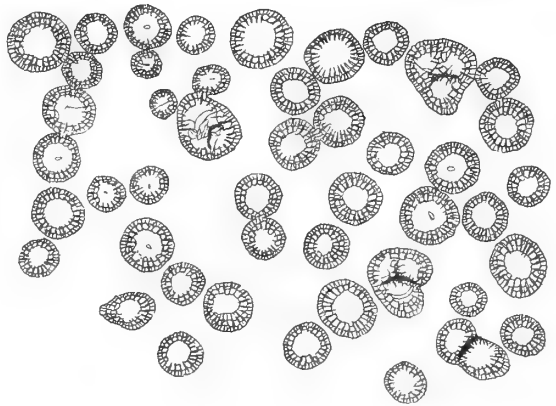

5 A

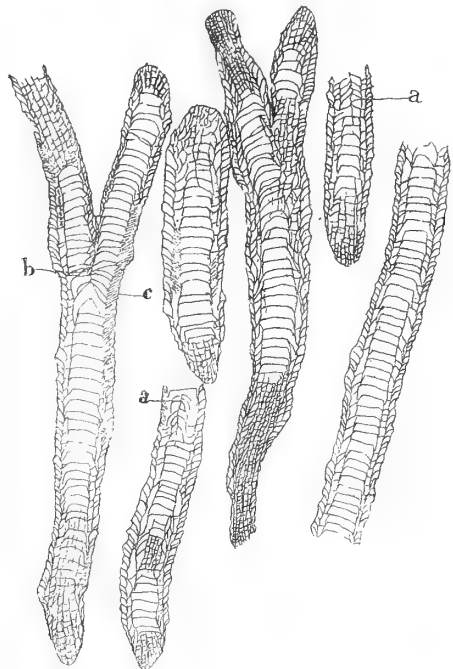

5

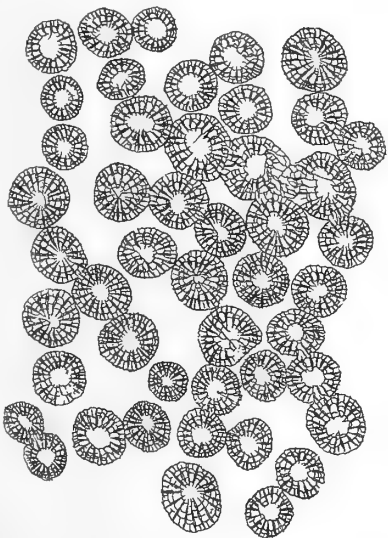



6

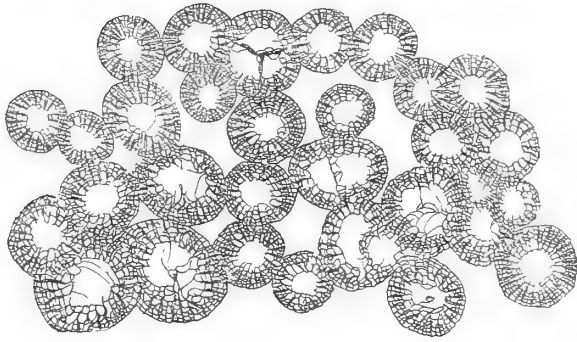

9

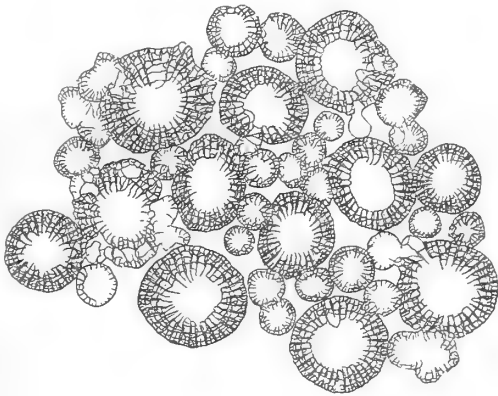

7

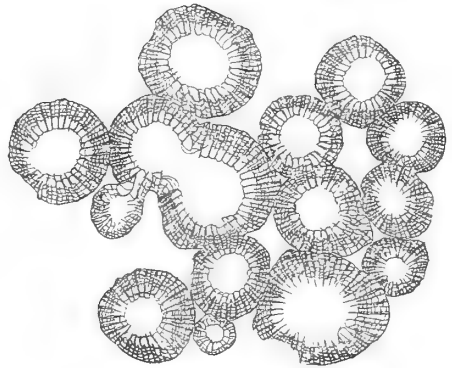

10

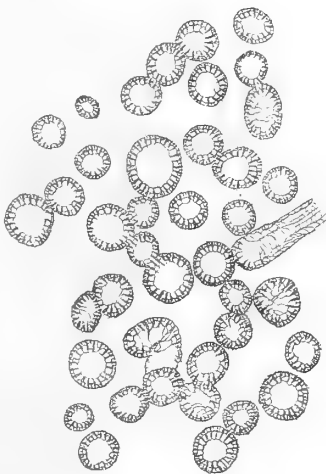

8

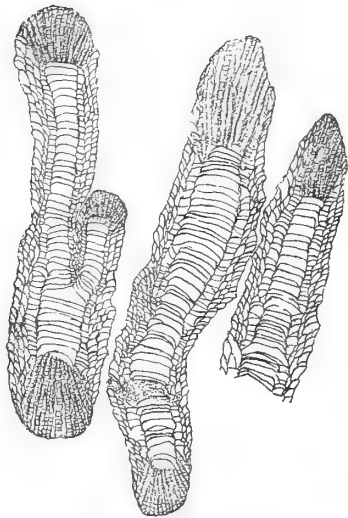



PLATE V.

- Fig. 6. *Diphyphyllum latiseptatum*, M'Coy, transverse section.
 7. ———, var. *giganteum*, transverse section.
 8. ———, ———, longitudinal section of corallites.
 9. ———, var. *interruptionum*, transverse section.
 10. ——— *gracile*, M'Coy, transverse section.

DISCUSSION.

Prof. DUNCAN, after drawing attention to Mr. Thomson's industry, stated that the communication settled the long-disputed value of *Diphyphyllum*, Lonsd. Lonsdale diagnosed the genus from indifferent specimens, and yet clearly established the absence of a columella and the presence of fissiparity in the forms. Mr. Thomson's beautiful specimens prove that Lonsdale was correct, and in addition show that there was also gemmation. It is now evident that the opinions of Milne-Edwards and Jules Haime about the genus are incorrect. In drawing attention to the different aspects of the calices of the Rugosa and of sections made lower down in the corallites, Prof. Duncan remarked that Mr. Thomson placed too great a classificatory value on the endothecal structures, which vary in the same coral.

Dr. HINDE inquired whether the diagrams exhibited related to distinct species or represented characters drawn from different species. Is it the case that both fissiparity and calicular gemmation occur in the same species?

Prof. DUNCAN thought the diagrams were intended to be general.

Prof. RUPERT JONES expressed himself favourably with regard to the paper and the specimens.

The PRESIDENT expressed his regret that Mr. Thomson was not present to receive the personal congratulations of the masters of palæontological science upon his interesting communication.

6. *On TERTIARY CHILOSTOMATOUS BRYOZOA from NEW ZEALAND.* By
ARTHUR WM. WATERS, Esq., F.G.S. (Read December 1, 1886.)

[PLATES VI.-VIII.]

IN the following paper the Chilostomata * from three collections are described, two being kindly lent by Miss Jelly, to whom they had been sent by a correspondent living in the neighbourhood of Napier. They are from Petane and Waipukurau, both representing a well-known horizon, and also some from Waikato † and Trig's Station, Tanner's Run, besides others designated as from the neighbourhood of Napier.

For the third collection, which is only small, I am indebted to the kindness of Professor Hutton, who collected the material from the base of the Shakespeare Cliff, Wanganui.

Petane, Waipukurau, and Wanganui are known localities in what is called the Wanganui system, which Tenison-Woods in his "Corals and Bryozoa of the Neozoic Period in New Zealand" (Colon. Mus. and Geol. Survey Dept. 1880), calls "Upper Miocene," but which Professor Hutton more recently (Quart. Journ. Geol. Soc. vol. xli. 1885, p. 194) calls "Newer Pliocene."

The only papers on New-Zealand fossil Bryozoa with which I am acquainted are those by Tenison-Woods, just mentioned, and one by Stoliczka, "On the Bryozoa from the Marine Beds of the Waitemataschichten of Orakei Bay." The Waitemata beds belong to the Pareora system, and are considered by both Woods and Hutton to be Miocene.

Of some few the state of preservation is very satisfactory, while with most this is by no means the case; yet it is often surprising to find how in badly preserved specimens the characters can be distinctly made out by a detailed examination of cell after cell. As an example, I had examined *Lepralia semiluna*, var. *simplex*, for over an hour before I could tell which was the right way up; but when at last I got the key and examined the best-preserved zoecia, the characters were made out as distinctly as in any fossil that I have yet examined.

The general appearance depends largely upon the conditions of fossilization, and with most of the fossils now examined is quite useless for specific separation; but during the last few years we have been taught how, in the recent forms, we must look almost entirely to the zoecial characters, and our knowledge of the fossils must be increased by a study of each character separately. It will most materially help the study of the recent Bryozoa when the descriptions are given of the separate organs with the organic integument removed, and this must be done before comparisons are made with fossils. Through the kindness of Miss Jelly I have been

* The description of the Cyclostomata will shortly follow.

† This is written "Whakati," but I have not been able to find out that there is such a place, whereas Bryozoa of this age are known from Waikato Heads.

C O P Y.

Canterbury College,
Christchurch, N.Z.
5 April 1887.

Dear Sir,

There are two or three small mistakes as to names of localities in your paper on Chilos. Bryozoa from N.Z. in Q.J.G.S. Feb, 1887 which I am sure you would like to correct.

Whakati is 14 miles north of Napier, quite different from Waikato.

Trig's Station - should be Trig. Station, Petane. It is the common colloquial for Trigonometrical Station of the Survey.

Napier has beds of two ages, Pliocene and Miocene, probably the fossils have got mixed. Petane is Pliocene only. Waipukurau is probably Miocene only, but Pliocene beds do occur a few miles off.

The first and second collections sent you were collected by A. Hamilton, Curator of the Museum at Napier and a most enthusiastic collector and naturalist.

He is rather annoyed at your calling him "the Napier correspondent", and I hope you will get an opportunity of mentioning his name as the collector. I believe he has sent further collections to you.

Yours truly,
F. W. Hutton.

A.W. Waters Esq.

P.T.O.

The original of this letter
is in the Waters Collection
at Manchester Museum.

H. Dighton Thomas.

7th Nov., 1947.

enabled to make such direct comparisons with most of the recent New-Zealand and Australian Bryozoa, making preparations of the covers and other parts, and, during the three years that these collections have been in my hands, have been preparing myself for dealing with the fossils by studying the recent forms.

There are some people who think it is possible to turn aside from other work and off-hand decide on the correctness of an author's interpretation; but, certainly with such a group as the present, criticism such as every author ought to be glad to receive can only be of value when the spirit of the work is entered into after prolonged examination. On this account it is much to be regretted that there are so lamentably few workers on fossil Bryozoa, whereas there are numbers of entirely new fields, and all the older work ought now to be revised from our present stand-point in classification.

The genus *Membranipora*, which is largely represented from near Napier, is not one of the most useful palæontologically, because (1) the shape of the oral aperture is never preserved, but only that of the opesial aperture, which is of but secondary diagnostic value; and (2) in this genus the appearance of the zoecia is remarkably modified by the presence of ovicells, but these are often wanting both in recent and fossil specimens. In fact, among the recent forms, the ovicells are not known in one half of the species, and even in some of the commonest, such as *M. pilosa*, they have not yet been found.

It will be seen from a reference to figures 2 and 5, 3 and 6 how very different the appearance in various parts of the same colony may be; and this is by no means confined to the genus *Membranipora*, but occurs in numerous genera, an example of which may be seen in different parts of *Microporella elevata*, T.-Woods (see Quart. Journ. Geol. Soc. vol. xli. pl. vii. figs. 6 and 9).

In nearly all the commoner species with wide-geographical range, such as *Microporella ciliata*, *Cribrilina radiata*, *Rhynchopora bispinosa*, *Cellepora coronopus*, *Cribrilina monoceros*, *Porella concinna*, &c., the mode of growth, the thickness, the structure of the shell, the size and number of spines*, the position of avicularia, and other characters are known to be liable to great variation, causing the appearance to be quite different. Yet notwithstanding this wide range in common species, it seems to be overlooked that the same is likely to be the case in species with which we are less acquainted; and the comparisons that I have been obliged to make in studying the characters of the fossils have convinced me that not only by those fresh in the field, but also by some of our most competent workers, local varieties, or even specimens, have in many cases been described as species. With the paucity of fossil material, it is impossible that this can always be avoided, but I would urge the advisability of more frequently indicating the relationships.

I have never been satisfied as to the separation of *Smittia* and *Mucronella*; and although we seem on the right track with regard to

* Thus we have *Membranipora Lacroixii* and *M. monostachys* with and without spines.

the classification of the Chilostomata, there are many points which require modification, and the peristomial characters all seem too variable to be used for wider classification.

A list of recent New-Zealand Bryozoa has been drawn up by Professor Hutton (Man. of N. Zealand Moll., Col. Mus. & Geol. Surv. Dept. 1880), and a large number have been described by Hincks in the 'Annals,' and some by Busk in the 'Challenger' Report, besides which, as already said, I have had the opportunity of examining a series, and now our knowledge of the Australian and New-Zealand fauna is being constantly increased by MacGillivray, Hincks, and other workers, so that, although much remains to be done, we are now gaining a fair knowledge of the Australian fauna. We must, however, always remember that in giving the proportion of any fossil series known living, this can only refer to the state of knowledge at one time; even since I commenced writing on the Australian fossils, dredging has brought to light several species at first indicated as only known fossil, so that the proportions then given are somewhat changed.

Besides those mentioned in this and previous papers, *Microporella coscinopora*, var. *armata*, has been found near Port Phillip Heads and Queen's Cliff. *Porella emendata*, Waters, has been described in the 'Challenger' Report (p. 155, pl. xx. fig. 5) as *Mucronella pyriformis*. Mr. Busk does not mention any avicularia, but in a specimen from Port Western I found avicularia to a few cells, placed diagonally as in the fossil. The fossil and recent forms agree in size and every particular.

Cellaria ovicellosa, Waters, has been sent to me recent from Australia by Miss Jelly, and is, no doubt, the *Salicornaria bicornis* of the 'Challenger' Report (p. 90).

Membranipora articulata, Waters, has since been described by Mr. Hincks as *Farciminaria appendiculata*; and I would take the opportunity of again urging the importance of decalcifying recent specimens, for often, as in this case, a very different appearance is given and fresh and important characters are seen. If this had been done, Mr. Hincks would have seen points which have escaped him, and, I think, would then have recognized that the species had already been described.

Micropora cavata, W., is *Aspidostoma giganteum*, Busk. In each paper fresh instances of species with two or more modes of growth have been given; such cases are constantly coming before me and new ones are mentioned in this paper. Recently Dr. Jullien* has made an important addition to our knowledge of the freshwater Bryozoa, and shown that, trusting to the mode of growth, a classification has been used which would often bring various specimens of a species under different genera, and that a revision similar to that which has been made of the Chilostomata is necessary with the Endoprocta.

Enough is not yet known about the New-Zealand and Australian Bryozoa to be able to fix their exact age with certainty, and this

* "Bryozoaires d'eau douce," par Dr. J. Jullien (Bull. Soc. Zool. de France t. x. 1885).

ultimately can only be done by taking into consideration the various groups of fossils; but the facies of those in hand is so recent, that we are inclined to think that some authors have attributed too great an age to the deposits containing them. That they are comparatively recent cannot be doubted, when we consider what a large number are known living in the New-Zealand seas, or are represented there by others very nearly related to them. Out of 78 species, or varieties, 61 are known living, 29 of these from New-Zealand seas, 48 from either New-Zealand or Australian waters, and 28 have been found fossil in Australia.

Figures of a few of the chitinous covers of species discussed are given, as they are the best indication of the shape of the true oral aperture. Figures 34 and 37 are copied and shaded from photographs, and on this account it has been convenient to give them on a larger scale than in my previous papers. Mr. Busk called them the "chitinous organs," which is a very incorrect term, as they cannot in any way lay claim to be organs, but only covers of organs. Neither the opercula nor the mandibles are universally chitinous, although usually so, and it would seem best, when they cannot be spoken of as opercula and mandibles, to call them Bryozoal covers.

With the exception of these and fig. 25 the figures are all magnified 25 times.

List of Species.*

	Page.	Living.	Napier.	Waipukurau.	Petane.	Trig's Station.	Shakespeare Cliff.	Australia (fossil).	Allies and Localities.
1. <i>Cellaria malvinensis</i> , <i>B.</i>	45	*Z	...	*	*	1, 2, 3, 4, 6	
2. <i>Membranipora monostachys</i> , <i>B.</i> ...	45	*Z	*		
3. — <i>lineata</i> , <i>L.</i>	45	*Z	*		
4. — <i>Lacroixii</i> , var. <i>grandis</i> , <i>W.</i> ...	45	...	*	*		
5. — <i>Dumerilii</i> , <i>Aud.</i>	45	*	*	*		Crag.
6. — <i>nobilis</i> , <i>Rss.</i>	46	...	*	*	*	2	Miocene.
7. — <i>solidula</i> , <i>Ald. & Hincks</i>	46	*AZ	...	*	*	...	*		
8. — <i>annulus</i> , <i>Manz.</i>	47	*	*	*	*	2	Napier Harbour.
9. — <i>cervicornis</i> , <i>Busk</i>	47	*A	2	
10. — <i>spinosa</i> , <i>Q. & G.</i>	48	*AZ	*	*		
11. — <i>Flemingii</i> , <i>B.</i>	48	*	*	5	
12. — <i>trifolium</i> , <i>S. Wood</i>	48	*	*		Crag.
13. — <i>occultata</i> , sp. nov.	48	*Z	*	*		
14. <i>Monoporella capensis</i> , <i>B.</i>	49	*	*	*	*		
15. —, var. <i>dentata</i> , nov.	49	...	*	*		
16. — <i>crassatina</i> , <i>W.</i>	49	*Z	*	*	*	2, 5, 6	Whakati.
17. — <i>disjuncta</i> , <i>Manz.</i>	50	*Z(?)	*	*		Pliocene (Italy).
18. — <i>waipukurauensis</i> , sp. nov.	50	...	*	*	*	...	*		
19. <i>Steganoporella neozelanica</i> , <i>B.</i>	50	*Z	*	*	*		
20. <i>Micropora lepida</i> , <i>Hincks</i>	51	*Z	*	*		
21. — <i>variperforata</i> , sp. nov.	51	*Z	*	*	...	*	...		Whakati.

* A or Z indicates that the form is known living in Australia or New Zealand. 1=Curdies Creek. 2=Mt. Gambier. 3=Bairnsdale. 4=Muddy Creek. 5=Aldinga. 6=Murray Cliffs.

List of Species (continued).

	Page.	Living.	Napier.	Waipukurau.	Petane.	Trig's Station.	Shakespeare Cliff.	Australia (fossil).	Allies and Localities.
22. Membraniporella nitida, <i>Johnst.</i> var.	52	*Z	* *						
23. Cribrilina monoceros, <i>B.</i>	52	*A	* ..	* ..	* ..			3	Petane marls.
24. ——— figularis, <i>Johnst.</i>	53	*	.. *	.. *	.. *			6	Crag.
25. ——— radiata, <i>Moll.</i> var. <i>Endlicheri</i> , <i>Rss.</i>	53								Napier Harbour.
26. Microporella ciliata, <i>Moll.</i>	53	*AZ	* *	* *	* ..			2	Whakati.
27. ——— Malusii, <i>Aud.</i>	54	*AZ	* ..	* ..	* ..				Bird Rock (Victoria).
28. ——— macropora, <i>Stol.</i>	54	*A	.. *	.. *	.. *				Miocene.
29. ——— decorata, <i>Rss.</i> , var. <i>angustipora</i> , <i>H.</i>	54	*Z	* *	* *	* *				
30. ——— magnirostris, <i>MacG.</i>	55	*A	.. *	.. *	.. *			2, 6	
31. Mucronella mucronata, <i>Sm.</i>	55	*A	* *	.. *			1, 2, 3, 4, 6	
32. ——— nitida, <i>Verrill</i>	55	*A	* *	* *			3, 6	Tommy Gully, Petane.
33. ——— præstans, <i>Hincks</i>	56	*Z	* ..	* ..	* ..			1, 2	Petane marls.
34. ——— Peachii, <i>Johnst.</i>	56	*	* ..	* ..	* ..				
35. ——— ———, var. <i>octodentata</i> , <i>H.</i>	56	*Z	* ..	* ..	* ..				
36. ——— alvareziiana, <i>d'Orb.</i>	57	*	.. *	.. *	.. *				Whakati.
37. ——— tricuspis, <i>Hincks</i>	57	*AZ	.. *	.. *	.. *				
38. ——— ———, var. <i>waipukurauensis</i>	57		.. *	.. *	.. *				
39. ——— porosa, var. <i>minima</i>	57		.. *	.. *	.. *				Petane marls.
40. ——— Liversidgei, <i>Woods</i>	58		.. *	.. *	.. *			2	Mount Gambier.
41. ——— firmata, sp. nov.	58		* ..	* ..	* ..				
42. Smittia reticulata, <i>MacG.</i>	58	*AZ	.. *	.. *	.. *			2, 3, 6	Whakati.
43. ——— Landsborovii, <i>Johnst.</i>	58	*A	.. *	.. *	.. *			6	
44. ——— biincisa, <i>W.</i> , var. <i>bicuspis</i> , <i>H.</i>	58	*Z	* ..	* ..	* ..				
45. ——— Napierii, <i>Waters</i>	59	*A	* ..	* ..	* ..				Wauru Ponds (Australia).
46. Porina grandipora, sp. nov.	59		* ..	* ..	* ..				{ Whakati, Napier Harbour, Miocene, Europe.
47. Lepralia Poissonii, <i>Aud.</i>	59	*AZ	* ..	* ..	* ..				
48. ——— rectilineata, <i>Hincks</i>	60	*Z	* ..	* ..	* ..				Tommy Gully (Petane).
49. ——— imbellis, <i>B.</i>	60		* ..	* ..	* ..				Wauru Ponds.
50. ——— pertusa, <i>Esper</i>	61	*	* ..	* ..	* ..			4	
51. ——— rostrigera, <i>Sm.</i>	61	*	* ..	* ..	* ..			6	
52. ——— longipora, <i>MacG.</i>	61	*A	.. *	.. *	.. *				
53. ——— semiluna, <i>Rss.</i> , var. <i>simplex</i>	62		* ..	* ..	* ..				Wauru Ponds.
54. ——— foraminigera, <i>Hincks</i>	62	*Z	.. *	.. *	.. *				
55. ——— bistata, sp. nov.	62		* ..	* ..	* ..				
56. Porella marsupium, <i>MacG.</i>	62	*A	.. *	.. *	.. *				
57. ——— ———, var. <i>porifera</i> , <i>H.</i>	63	*	* ..	* ..	* ..				
58. ——— concinna, <i>B.</i>	63	*A	.. *	.. *	.. *			2	Tommy Gully (Petane).
59. Hippothoa flagellum, <i>Manz.</i>	63	*Z	.. *	.. *	.. *				
60. Schizoporella circinata, <i>MacG.</i>	64	*AZ	.. *	.. *	.. *				
61. ——— auriculata, <i>Hass.</i>	64	*A	* ..	* ..	* ..			2, 3	Tommy Gully (Petane).
62. ——— Ridleyi, <i>MacG.</i>	64	*A	.. *	.. *	.. *				
63. ——— marsupifera, <i>B.</i>	65	*AZ	.. *	.. *	.. *				
64. ——— biaperta, <i>Mich.</i>	65	*ZA	.. *	.. *	.. *				
65. ——— cribrilifera, <i>Hincks</i>	65	*Z	.. *	.. *	.. *				Petane marls.
66. ——— clavula, <i>Manz.</i>	65		* ..	* ..	* ..				Italian Miocene.
67. ——— conservata, <i>Waters</i>	65	*A	* ..	* ..	* ..			1, 2	
68. ——— obliqua, ? <i>MacG.</i>	66	*A	* ..	* ..	* ..				
69. ——— cinctipora, <i>H.</i> , var. <i>personata</i>	67	*Z	.. *	.. *	.. *				
70. ——— tuberosa, <i>Rss.</i> , var. <i>angustata</i>	67		* ..	* ..	* ..				
71. ——— hyalina, <i>L.</i>	68	*AZ	.. *	.. *	.. *				Tommy Gully (Petane).
72. Cellepora albirostris, <i>Sm.</i>	68	*A	* ..	* ..	* ..			6	
73. ——— tridenticulata, <i>B.</i>	68	*A	.. *	.. *	.. *			5, 6	Yorke's Peninsula (Aust.).
74. ——— coronopus, <i>S. Wood</i>	68	*	* ..	* ..	* ..			2, 5	
75. ——— costata, <i>MacG.</i>	68	*A	.. *	.. *	.. *				Miocene (Europe).
76. ——— decepta, sp. nov.	69		* ..	* ..	* ..				
77. Rhynchopora longirostris, <i>H.</i>	70	*A	* ..	* ..	* ..				
78. Lunulites petaloides, <i>d'Orb.</i>	70		* ..	* ..	* ..			2, 4	Bird Rock.

1. *CELLARIA MALVINENSIS*, Busk.

Cellaria malvinensis, Waters, Quart. Journ. Geol. Soc. vol. xli. p. 285.

Loc. Living: various localities in the Southern Hemisphere. Fossil: Australia; Nelson (*H.*), Waipukurau and Shakespeare Cliff (New Zealand).

2. *MEMBRANIPORA MONOSTACHYS*, Busk. (Pl. VI. figs. 3 & 6.)

Membranipora monostachys, Busk, Brit. Mus. Cat. p. 61, pl. lxx.

For synonyms see Hincks, Brit. Mar. Polyzoa, p. 131.

A specimen from Napier has a large spine below the aperture and numerous smaller ones round the opesia. The ovicell, which has not been previously seen in *M. monostachys*, is subglobose, with a strong rib on the front enclosing a subtriangular or suboval space, which is divided into two equal parts by a median rib. The ovicell, in structure, somewhat resembles that of *M. aurita*, Hincks, and the raised rib on the ovicell occurs in many *Membranipora*, such as *M. lineata*, *M. galeata*, *M. unicornis*, *M. sophie*, *M. circumclathrata*, *M. dentata*, &c. This differs from *M. lineata* in having a large spine below the opesia, but there is no doubt that this, *M. pilosa*, and *M. pyrula*, Hincks, are closely allied. The ovicell is like that of *M. valdemunita*, Hincks. Miss Jelly has a recent specimen from Napier with similar ovicells.

Loc. Fossil: Napier.

3. *MEMBRANIPORA LINEATA*, L.

In a fossil from Shakespeare Cliff the zoecium has a thick border and was surrounded with spines. The ovicell is short, and between the zoecia there are interspersed small cells, with a small, round, or elongate opening; these I have sometimes called blind cells.

The form of the ovicell seems to indicate that this is *M. lineata*; but as there are several species closely allied, it is difficult to speak with certainty in such a case.

4. *MEMBRANIPORA LACROIXII*, Aud., var. *GRANDIS*. (Pl. VI. fig. 1.)

There are several specimens of *Membranipora* from Napier which I cannot identify with certainty, but which will be recognizable when again found. The opesia, 0.4 millim. long, is oval, occupying nearly a third of the zoecia, and has a distinct border upon which I do not find any spines.

The space between the zoecia sometimes bears an avicularium, but more often is divided into two or three spaces, sometimes with punctures. The ovicell, which is unknown in the typical *M. Lacroixii*, is large, raised, globose.

This is allied to my *M. tripunctata*, but the narrow longitudinal band between the zoecia is wanting.

5. *MEMBRANIPORA DUMERILII*, Aud. (Pl. VI. fig. 4.)

Flustra Dumerilii, Aud., Savigny, Descr. de l'Egypte, pl. x. fig. 12.

For synonyms see Brit. Mar. Polyzoa, p. 156.

Although the ovicell is wider than usual, I think this must be regarded as *M. Dumerilii*, and probably the number of synonyms should be largely increased, as there are many fossil *Membranipora* described with a small avicularium at the base of each zoecium. In a recent British *M. Dumerilii* in my collection there is also a vicarious avicularium with the lower part wide and circular and the mandibular end narrow.

A curious mistake has been made in uniting *Cribrilina Pouilletii* to this. This latter is pl. ix. fig. 12 of Audouin; but Alder made a slip between pls. ix. & x., and Busk followed him, evidently without verification.

Loc. Living: European seas. Fossil: Crag; Waipukurau.

6. MEMBRANIPORA NOBILIS, Rss. (Pl. VI. figs. 7 & 10.)

Membranipora nobilis, Reuss, Foss. Polyp. des Wien. Tertiärbeckens, p. 98, pl. xi. fig. 26.

Zoarium adnate. Zoecia oval, surrounded by a border; in one or two cases a vicarious avicularium with semicircular mandible. Ovicell small, smooth, with a border round the central portion.

This much resembles *M. flustroides*, Hincks, in shape and character: but in the fossil the avicularium is larger, the spines are wanting, and the ovicell is somewhat deeper. A round avicularium only occurs in a few *Membranipora*, such as *M. crassimarginata*, H., *M. lineata*, Manzoni (Bry. of Castrocaro, p. 11, pl. i. fig. 6), *M. flustroides*, H.

A specimen from Napier has the cells, in part of the colony, very elongate, showing that *M. ovalis*, d'Orb., is only a modification of this species.

Loc. Miocene: Austerlitz. Napier and Petane (N. Z.); Mt. Gambier.

7. MEMBRANIPORA SOLIDULA, Alder & Hincks.

Membranipora solidula, Hincks, Proc. Dublin Univ. Zool. & Bot. Assoc. n. pt. i. (1869) p. 75: and Brit. Mar. Polyzoa, p. 158, pl. xx. figs. 7, 8.

Membranipora papulifera, MacGillivray, Trans. Roy. Soc. Vict. vol. xviii. p. 116.

Biflustra papulifera, MacGillivray, Zool. of Victoria, decade xi. p. 27, pl. 106. fig. 9.

A fossil from Shakespeare Cliff, growing on *Entalophora*, has the zoecia plain, suboval, with a thick crenulated border, and a globose ovicell, which is shallow and smooth, with a strong thickened ridge across the upper part. In size and structure of the ovicell this is just the same as specimens from Hastings and Capri, but I do not find any nodules. This, however, in several other species is not a constant character. A specimen from Waipukurau Gorge, which was sent to me queried as *M. papulifera*, is of the same size as the one from Shakespeare Cliff.

Loc. Living: Antrim, Guernsey, Hastings (H.), Capri (A. W.),

Port Phillip Heads (*MacG.*), New Zealand (*Miss Jelly*). Fossil: Shakespeare Cliff (Wanganui), Waipukurau Gorge.

8. *MEMBRANIPORA ANNULUS*, Manz. (Pl. VI. figs. 2, 5, & 9.)

Membranipora annulus, Manzoni, Bry. foss. Ital. 4a cont. p. 7, pl. i. fig. 6 (?); and Bri. di Castrocaro, p. 12, pl. i. fig. 9.

Membranipora dentata, Waters, Quart. Journ. Geol. Soc. vol. xxxviii. p. 263, pl. viii. fig. 14.

Membranipora galeata, Busk, Brit. Mus. Cat. p. 62, pl. lxxv. fig. 5; "Zool. of Kerguelen Island," Phil. Trans. clxviii. p. 195.

There are a number of closely allied forms which, through variations in the shape of the opesial opening, often differ considerably in appearance, but agree in having a central avicularium, supported by two strong spines on each side, sometimes cervicorn, and an ovicell widely open with a raised line arching across the front, a short distance above the opening, enclosing a narrow depressed area. These allies are *M. patula*, Hincks, *M. cervicornis*, B., *Flustrellaria dentata*, d'Orb.

The present form, which I at first thought should be called *M. dentata*, d'Orb., has usually an oval opening; *M. patula* has the lower edge straight; *M. cervicornis*, B., which is no doubt the same as *M. perversa*, Waters, fossil from Mt. Gambier, has the opesia usually nearly straight above and rounded below; but in a large colony of any of these species opesia will be found with very different shapes.

In the New-Zealand fossils the large avicularium on the ovicell is directed downwards to the distal wall.

One specimen from Napier and one from Waipukurau are bilaminate, but the others are adnate. We have also seen *M. cervicornis* (*perversa*, W.) in the *Vincularia*-form. Some specimens have an avicularium below the opesia.

An examination of the British-Museum specimens of *Membranipora galeata*, B., made since my plates were prepared, shows that this is identical with the fossil. The depressed area on the ovicell, which Mr. Busk seems to have overlooked, is very marked; occasionally there are two avicularia, and the cells without ovicells, with the avicularian chamber projecting forwards, exactly resemble my fig. 5.

As Mr. Busk's description was quite insufficient, it will be best to retain Manzoni's name.

Loc. Living: Swains Bay, E. Falkland, in 4-10 fath. (*Darwin*, fide *Busk*). Fossil: Pliocene of Castell-Arquato, Parlascio, Orciano, Castrocaro (*M.*); Mt. Gambier (Australia); Napier, Waipukurau and Petane (New Zealand).

9. *MEMBRANIPORA CERVICORNIS*, Busk (non Haswell).

Membranipora cervicornis, Busk, Cat. Mar. Polyzoa, p. 60, pl. c. fig. 3; MacGillivray, Zool. of Victoria, decade iii. p. 32, pl. xxv. fig. 8; Hincks, Ann. & Mag. Nat. Hist. ser. 5, vol. vii. p. 153.

Membranipora perversa, Waters, Quart. Journ. Geol. Soc. vol. xxxviii. p. 264, pl. ix. fig. 32.

Amphiblestrum cervicorne, Busk, Rep. 'Challenger,' Polyzoa, p. 66.

Loc. Living: Williamstown (Victoria), Curtis Island (*H.*). Station 162, 38 fath. (*B.*), Bondi Bay (N. S. Wales), Adelaide and Port Phillip Heads (*A. W. W. coll.*). Fossil: Mt. Gambier and Napier.

10. MEMBRANIPORA SPINOSA, Quoy & Gaimard. (Pl. VIII. fig. 32.)

Flustra spinosa, Q. & G. Voy. de l'Astrolabe.

Membranipora ciliata, MacGillivray, Trans. R. Soc. Vict. 1868, p. 7; *ibid.* vol. xviii. p. 3, fig. 11; Zoology of Victoria, decade iii. p. 30, pl. xxv. fig. 3.

Membranipora spinosa, Busk, Trans. Roy. Soc. vol. clxviii. p. 195, pl. x. fig. 3; and 'Challenger' Report on the Polyzoa, p. 64; Hincks, Ann. & Mag. Nat. Hist. ser. 5, vol. vii. p. 150.

Chaperia australis, Jullien, "Bry. Cheil." Bull. Soc. Zool. 1881, vol. vi. p. 1 (sep.).

In the fossil from Napier and in a recent specimen from New Zealand there is an elongate lateral chamber on each side below the operculum, and a similar structure occurs also in *M. annulus*, but rather lower down. The length of the opesia opening is in both about 0.25 millim.

Loc. Living: Victoria, Kerguelen Island, S. Patagonia, N. S. Wales, New Zealand. Fossil: Napier, N. Zealand.

11. MEMBRANIPORA FLEMINGII, Busk.

Membranipora Flemingii, Busk, Cat. B. M. ii. p. 58, pl. lxxxiv. figs. 3-5 only; Hincks, Brit. Mar. Polyzoa, p. 162, pl. xxi. figs. 1-3; Waters, Quart. Journ. Geol. Soc. vol. xli. p. 288.

Loc. Living: European Seas. Fossil: Aldinga (Australia), Napier.

12. MEMBRANIPORA TRIFOLIUM, S. Wood. *Amphiblestrum*

For synonyms see Hincks, Brit. Mar. Polyzoa, p. 167.

The fossil from Napier has zoëcia about half as large again as specimens in my collection from the English Crag.

The opesia of the Crag specimens are 0.15 millim. wide; these are 0.25 mm., and *M. appendiculata*, which is related (see Q. J. G. S. vol. xxii. p. 504), has the opesia about 0.4 millim. wide. I am much inclined to think that it would be best to follow Smitt and call this *M. Flemingii*, var. *trifolium*. In the New-Zealand fossil the ovicell is flatter on the front than I have before seen.

Loc. Living: Northern Seas. Fossil: Crag, and Napier.

13. MEMBRANIPORA OCCULTATA, sp. nov. (Pl. VI. figs. 12, 13, and Pl. VIII. fig. 40.)

Zoarium adnate. Zoëcia quadrate, sloping inwards towards the opesia, with three spines on the upper border. Opesia nearly straight below, rounded above, with the sides nearly straight, and a broad serrated edge or denticle on the proximal border. In the

older parts there is a thick calcareous deposit between the cells, so that the mouth is buried at the bottom of a deep cavernous opening, and in the raised calcareous part there are numerous triangular avicularia.

A number of the chief characters remind us of *Rhynchopora profunda*, MacGillivray (New or Little-known Polyzoa, pt. iii. p. 2, fig. 8), and possibly some of the characters are hidden by the calcareous growth in MacGillivray's specimen. I should not have been able to make out all the characters from the fossils, but, having seen them in recent specimens, the fossils became quite clear.

Loc. Living: New Zealand. *Fossil:* Napier (N. Z.).

14. MONOPORELLA CAPENSIS, Busk.

Amphiblestrum capense, Busk, 'Challenger' Report on the Polyzoa, p. 67, pl. xxiii. fig. 3.

Such a form as the present shows at what a great disadvantage the palæontologist is placed in consequence of being unable to find out the form of the Bryozoal covers, for there are many species of *Membranipora* resembling the present species in the shape of the opening; but these, such as *M. dentata*, *M. angulosa*, &c., have a small opercular aperture in the membrane covering the opesia. In this species, on the other hand, the opening is entirely closed by a subcircular or elliptical operculum.

In a recent specimen in my collection, from Algoa Bay, South Africa, the zoarium is erect, cylindrical, or subcompressed, just as figured by Busk, and some cells have the two spines as described; but the majority are without spines, and in none of the fossils do I find any traces of them. The Napier and Waipukurau fossils are both adnate, whereas the one from Shakespeare Cliff is a flat bilaminar fragment. Opesia of all 0.3 mm. wide. Both *Flustrellaria tubulosa*, d'Orb. (Pal. Fr. pl. 727. fig. 10), and *Biflustra Pražáki*, Novak (Böhm. Kreide, p. 18, pl. iii. figs. 20-25), are closely allied to this.

Loc. Living: Simon's Bay, Cape of Good Hope (B.); Algoa Bay (W.). *Fossil:* Waipukurau, Wanganui, and Napier.

15. MONOPORELLA CAPENSIS, B., var. DENTATA, nov. (Pl. VIII. fig. 39.)

There is a specimen from Napier which, on account of a curious structure, it may be best to regard as a variety. In the upper part of the zoecium there appear to be two denticles extending some little distance below the aperture, but these are only a prolongation of a tube from one zoecium to another; in the middle of this tube is the rosette-plate. The distal rosette-plate is, in many cases (as, for example, *Lepralia foliacea*), in the middle of what we may call a rosette-tube; but I know of no other instance in which it is prolonged in this way.

16. MONOPORELLA CRASSATINA, Waters. (Pl. VII. fig. 15.)

Monoporella crassatina, Waters, Quart. Journ. Geol. Soc. vol. xxxviii. p. 270, pl. vii. fig. 8; *ibid.* vol. xxxix. p. 435, and vol. xli. p. 291.

Having seen a recent specimen from New Zealand, and having

a fossil with a very large, much raised ovicell, both broader and longer than the length or width of a zoëcium, I now think that I made a mistake in uniting *Lepralia japonica* of Busk with this species, although they are no doubt closely allied.

The operculum of the recent specimen from New Zealand is thick, membranous, not chitinous, except at the borders, and has two lateral projections directed towards the basal wall of the zoëcium, showing similarity, in this respect, to *Membranipora* and *Cellaria*. It is about 0.35 mm. wide.

Loc. Living: New Zealand (*A. W. W. coll.*). Fossil: Mount Gambier, Wauru Ponds, Aldinga and River-Murray Cliffs (Australia), Napier, Waipukurau and "Whakati" (New Zealand).

17. *MONOPORELLA DISJUNCTA*, Manz. (Pl. VI. fig. 8.)

Lepralia disjuncta, Manzoni, Bry. Plioc. Ital. cont. 1a, Denkschr. Ak. Wissensch. Wien, vol. lix. 1869, p. 5, pl. i. fig. 8, and Bri. del Plioc. di Castrocaro, p. 26, pl. iii. fig. 35.

? *Lepralia urceolata*, Hutton, Manual of New Zealand Moll. 1880, p. 192.

? *Lepralia Auingeri*, Rss. Foss. Bry. Œst. Ung. p. 166, pl. viii. fig. 2.

Zoarium adnate. Zoëcia subovate, distinct, not very much raised, surface covered with very minute granulations. Four spines above the oral aperture, which is large, rounded above, straight below (0.25 mm. wide).

This I at first called *Monoporella crassatina*, W., var. *micrograna*, but it seems to be identical with the *disjuncta* of Manzoni, and this and the last species no doubt are related to *M. polita*, Norm.

Loc. Living: New Zealand? Fossil: Pliocene, Castell-Arquato, Castrocaro (Italy); Napier (New Zealand). *

18. *MONOPORELLA WAIPUKURENSIS*, sp. nov. (Pl. VI. fig. 11.)

Zoarium adnate. Zoëcia oblong, distinct, arranged in parallel series. Oral aperture (0.15 mm.) about half or a third of the width of the zoëcium, straight below, rounded above, with an umbo below the aperture. Ovicell small, globular, raised; surface of zoëcium and ovicell punctured.

The figure of *Lepralia rubens*, Stimpson, looks like this species, and the fossil is no doubt closely allied to *Cyclicopora praelonga*, Hincks; but from comparison of specimens in my collection they do not seem to be identical.

Loc. Napier, Waipukurau cutting, and Trig's Station.

19. *STEGANOPORELLA NEOZELANICA*, Busk.

Vincularia neozelanica, Busk, Quart. Journ. Micr. Sci. n. s. vol. i. p. 155, pl. xxxiv. fig. 5.

Steganoporella neozelanica, Hincks, Ann. & Mag. Nat. Hist. ser. 5, vol. ix. p. 82, pl. v. fig. 9.

It is exceedingly difficult to distinguish *S. magnilabris* and *S. neozelanica* without the opercula, and the determination of fossils

therefore requires great care. In *S. magnilabris* the shelf at the upper part of the opercular opening is much wider than in *S. neozelanica*, in which it is usually quite rudimentary; the lip is also wider and much raised, forming a support for the base of the operculum. The tubular passage is also more distinct in *S. magnilabris*. None of these characters are very satisfactory, as they are all subject to more or less variation. The fossils from Curdies Creek, Mount Gambier, Bairnsdale, Batesford, and Murray Cliffs (Australia) all show the *magnilabris* characters; but a further examination of the Waipukurau and Petane fossils shows that they are *S. neozelanica* in the *Lepralia*-stage.

Loc. Living: New Zealand. Fossil: Waipukurau, Petane, and Napier (New Zealand).

20. MICROPORA LEPIDA, Hincks.

Monoporella lepida, Hincks, Ann. & Mag. Nat. Hist. ser. 5, vol. viii. p. 59, pl. ii. fig. 2.

The fossil from Napier, New Zealand, corresponds in size with a recent specimen from New Zealand. The oral aperture in both is 0.1–0.12 mm.

Loc. Fossil: Napier. Living: Curtis Island (*H.*); New Zealand (*E. C. J.*).

21. MICROPORA VARIPERFORATA, sp. nov. (Pl. VIII. fig. 27.)

This species has caused me great difficulty, as there are apparently two Australian and New-Zealand species, or varieties, most closely allied, and on none of the characters alone could the separation be made. The first of these two is slightly the larger, but has a narrower operculum (0.12 mm.), relatively longer from the proximal to the distal edge, with lateral hinges as in *Membranipora*, and the whole surface is similar in texture; there are two lateral spines. The ovicell is large and not much raised, and the oral aperture of the ovicelligerous zoecia is larger than that of the non-fertile ones. On each side a little below the orifice there is a large circular perforation, and in some specimens many zoecia have a few supplementary pores, usually smaller, round the edge of the cell; the avicularium is smaller than in the following form, and the mandible has a small central opening.

This is *Membranipora stenostoma*, Busk (Cat. Mar. Polyzoa, p. 60, pl. c. fig. 1), but the insufficient description has made it impossible to be sure what was meant, and therefore the name must be dropped as it has since been more fully described as *M. perforata*, MacG. The aperture of the ovicelligerous zoecium is figured by Busk larger than that of the other zoecia; but no difference in size is mentioned; his figure has been drawn from a specimen covered with an integument, and the large openings on each side have been overlooked, although they are very distinct in the Museum slide.

The second form, which I now separate with some doubt and call *variperforata*, on the other hand, has an operculum 0.14 mm. wide, with the upper half the thickest and the lower composed of

two layers; the avicularium is smaller, but the opening on the mandible is larger; the ovicell is smaller and more concealed. In this also there is a similar perforation, and also, in some cases, others round the edge of the cell; but this seems to be rare.

The fossils from Napier, Waipukurau, "Whakati," and Trig's Station agree with this last; and while some specimens may have an avicularium to almost every cell, in others they are seldom found, and in one case they seem to be altogether absent. In many zoecia there is a projecting boss, which seems to be imperforate, replacing the avicularium.

These two forms are evidently closely allied to *M. coriacea*, but differ in not having a knob. The "knob" of *M. coriacea* forms a chamber which communicates with the interior by means of a rosette-plate. (I have already, in a Report to the British Association on the Naples Zoological Station, 1880, pointed out that rosette-plates occur at the base of the spines of *Memb. cervicornis*.) It is also allied to *Micropora lepida*, Hincks, to which it is very similar in appearance when there is a row of pores round the edge. The mandible of *M. coriacea* has a central ridge from the beak, and the same structure is seen in the other two species.

22. MEMBRANIPORELLA NITIDA, Johnst., var. (Pl. VII. fig. 18.)

There are two fossil specimens from Waipukurau, which differ from recent ones from "New Zealand" only in having four spines, and this is probably not a very important character. The lower lip is thickened, and this is the case in a recent specimen from Capri; the ovicell has often more or less of a keel, and has a ridge which cuts off the lower part, and in this respect resembles *M. distans*, MacGillivray (Descrip. of New or Little-known Polyzoa, pt. 2, pl. ii. fig. 5). In the fossils there are no avicularia, whereas in a recent specimen of this variety from New Zealand there is a large spatulate vicarious avicularium, like that figured by Busk for *Cribrilina philomela*, var. *adnata*. The costæ vary from five to eight on a side.

We seem now to have various links, recent and fossil, between *C. figularis*, *C. philomela*, and *Membraniporella nitida*, and there is no hard and fast line between *Cribrilina* and *Membraniporella*.

Loc. Living: New Zealand. Fossil: Napier, Waipukurau.

23. CRIBRILINA MONOCEROS, Busk (non Reuss).

Lepralia monoceros, Busk, Brit. Mus. Cat. p. 72, pl. xcii. figs. 5 and 6; MacGillivray, Zool. of Victoria, decade iv. p. 32, pl. 38. figs. 1 and 2; Ridley, Zool. Coll. 'Alert,' Proc. Zool. Soc. 1881, p. 51.

Cribrilina monoceros, Hincks, Ann. & Mag. N. H. ser. 5, vol. viii. p. 57, pl. iii. fig. 6, and vol. xiv. p. 279, pl. viii. fig. 5; Waters, Q. J. Geol. Soc. vol. xxxviii. p. 507; Busk, Rep. of 'Challenger' Polyzoa, p. 133, pl. xix. fig. 8.

In the Napier fossil the size of the aperture corresponds with that of recent specimens and of the Bairnsdale fossil. In a recent

specimen from Port Western there are lateral denticles and a contraction some distance down the aperture, which may represent the teeth, which are so marked in the Bairnsdale fossil, but have not been found elsewhere. I believe that *L. monoceros* and *L. larvalis* MacGillivray are entirely different.

Loc. Living : Straits of Magellan, 10–20 fath., Tierra del Fuego, 19 fath., Falkland Islands, 4–10 fath., Cape Horn, 40 fath. (*B.*); Elizabeth Island, 6 fath., Sandy Point, 7–10 fath., Tom Bay, 0–30 fath. (*R.*); Bass's Straits (*H.*); Warrnamboul (*MacG.*); 'Challenger:' station 163; Port Jackson, 35 fath.; st. 303, 1325 fath.; st. 235, N. Pacific, 3125 fath.; st. 315, 12 fath. Fossil : Bairnsdale (Victoria) in Eschara-form, Napier (N. Zeal.) adnate, Petane.

24. CRIBRILINA FIGULARIS, Johnst.

Cribrilina figularis, Waters, Quart. Journ. Geol. Soc. vol. xli. p. 293.

Specimens from Waipukurau are very distinctly carinate down the centre, and there is a considerable margin of smooth cell; the ovicells are those characteristic of *figularis*, but I do not find any avicularia. Perhaps this is *Lepralia Haueri*, Rss.

Loc. Living : European Seas, Marion Islands, and Heard Islands. Fossil : Crag; River-Murray Cliffs, Waipukurau.

25. CRIBRILINA RADLATA, Moll, var. ENDLICHERI, Rss.

Lepralia Endlicheri, Reuss, Foss. Polyp. Wien, p. 82, pl. ix. fig. 27, and Foss. Bry. Œst. Ung. Mioc., Denkschr. Ak. Wissensch. Wien, vol. xxxiii. p. 171, pl. i. fig. 9.

A fossil from Napier Harbour has short, broad, oval zoecia with very solid shell. The ribs are irregular, usually 6 or 7 on a side. The oral aperture is larger (0.15 mm.) than that of typical *C. radiata*, and below it there is a distinct raised tubular pore surrounded by a border, so that it appears marsupiate. The ovicell is about the width of a zoecium, and, as far as can be judged, this has a radiate structure. The *L. Endlicheri* of Reuss has been found in several Miocene localities of Austria and Hungary.

26. MICROPORELLA CILIATA, Pall.

Eschara ciliata, Pall. Elench. p. 38, and for synonyms see Hincks, Brit. Mar. Polyzoa, p. 206.

Lepralia calabra, Seguenza, "Formazioni Terziarie," Accad. Lincei, cclxxvii. p. 201, pl. xv. fig. 6.

The fossil from Trig's Station has a large round suboral pore on a prominent mucro, and the avicularian opening is nearly round; surface punctured. Oral aperture 0.1 mm. wide, with six spines. This form is the *Lepralia pleuropora*, Rss. Foss. Bry. Œst. Ung. Mioc. p. 153, pl. iv. fig. 11.

The specimens from "Whakati" and Napier have a smaller round or lunate suboral pore with larger avicularian (vibracular) opening, and the avicularian chamber forms a tube or tunnel with the opening

directed towards the centre of the zoecium. This form is the *M. calabra* of Seguenza.

The specimen from Waipukurau has rather smaller zoecia than the others, but the oral aperture of all is about 0.1 mm. wide.

Loc. Living: Cosmopolitan. Fossil: Miocene, Austria and Hungary; Pliocene, Italy and Sicily, English Crag, Mount Gambier (Australia), Napier, Waipukurau, and Trig's Station (New Zealand).

27. MICROPORELLA MALUSII, Aud.

Microporella Malusii, Aud., Waters, Q. J. Geol. Soc. vol. xxxix. p. 437.

Loc. Living: European seas, S. America, N. Zealand, Australia. Fossil: English Crag, and Pliocene of Italy, Bird Rock (Victoria), Napier, Petane (N. Zealand).

28. MICROPORELLA (?) MACROPORA, Stol.

Lepralia macropora, Stoliczka, Olig. Bry. von Latdorf, p. 84, pl. ii. fig. 3; Sitz. Ak. Wien, Math.-nat. Cl. Bd. xlv. Abth. i. 1862.

Escharipora stellata, Smitt, Floridan Bryozoa, p. 26, pl. vi. figs. 130-133.

Microporella macropora, Waters, Quart. Journ. Geol. Soc. vol. xxxviii. p. 267, pl. viii. fig. 18.

Microporella stellata, MacGillivray, "New or Little-known Polyz." pt. 2, Tr. Roy. Soc. Vict. vol. xix. p. 131, pl. i. fig. 4.

The fossil from Waipukurau has an avicularium at each side of the aperture, and should, as I have before pointed out, perhaps be called var. *biarmata* on that account; and I have again to repeat that although no suboral pore is known, the general characters are those of *Microporella*, the genus in which Professor MacGillivray has also placed it.

Loc. Living: Port Phillip Heads (*MacG.*); Port Phillip (*W.*); Florida (*Sm.*). Fossil: Miocene, Latdorf (with one avicularium); Waipukurau.

29. MICROPORELLA DECORATA, Rss., var. ANGUSTIPORA, Hincks.

Microporella diadema, MacG., form *angustipora*, Hincks, Ann. & Mag. Nat. Hist. ser. 5, vol. xv. p. 249, pl. viii. fig. 3.

MacGillivray and Hincks have made several varieties of *M. diadema*; but it seems to me that they should be called varieties of *M. decorata*, Rss. In the typical *M. decorata* the avicularium is directed directly distally, and in the recent forms there is considerable variation, as, for example, between var. *lata* and var. *lunipuncta*, MacG.

In a fossil specimen of the typical *M. decorata*, from Vigna di Mare, near Reggio, Calabria, the shape of the ovicell is the same as in var. *diadema* and *lunipuncta*, and, so far as the state of preservation allows of comparison, the other characters are the same.

It seems to me that we should divide this group into *M. decorata*, Rss., *typica*; var. *diadema*, MacG.; var. *angustipora*, Hincks; var.

lunipuncta, MacG. ; var. *longispina*, MacG. ; var. *lata*, MacG. ; var. *canaliculata*, MacG.

Loc. Living : New Zealand. Fossil : Waipukurau, Napier, Petane, and Trig's Station (New Zealand).

30. MICROPORELLA MAGNIROSTRIS, MacG.

Lepralia magnirostris, MacGillivray, Trans. Roy. Soc. Vict. vol. xix. p. 134, fig. 6.

Microporella magnirostris, Waters, Quart. Journ. Geol. Soc. vol. xli. p. 296.

Microporella introversa, Waters, Quart. Journ. Geol. Soc. vol. xxxviii. p. 263, pl. ix. figs. 33, 34.

Porina magnirostris, Hincks, Ann. & Mag. Nat. Hist. ser. 5, vol. xiv. p. 279.

Both specimens from Waipukurau are in the *Eschara*-stage, and in the one from "W. cutting" it forms a contorted undulating anastomosing mass.

Loc. Living : Port Phillip Heads. Fossil : Mt. Gambier, River-Murray Cliffs, Waipukurau and "Waipukurau cutting."

31. MUCRONELLA MUCRONATA, Smitt.

Mucronella mucronata, Waters, Quart. Journ. Geol. Soc. vol. xli. p. 293.

Loc. Living : Florida. Fossil : Curdies Creek, Mt. Gambier, Bairnsdale, Muddy Creek, and Murray Cliffs (Australia), Napier (New Zealand).

32. MUCRONELLA NITIDA, Verrill.

For synonyms, see Waters, Quart. Journ. Geol. Soc. vol. xli. p. 293, to which add

Smittia reticulata, var. *spathulata*, MacGillivray, Trans. Roy. Soc. Victoria, vol. xix. p. 135, pl. iii. fig. 14.

Smittia reticulata, MacG., var., Hincks, Ann. & Mag. Nat. Hist. ser. 5, vol. viii. p. 64.

Although MacGillivray describes his variety as with spathulate avicularia, the avicularium figured can scarcely be called spathulate, and in the shape there seems to be great variability. I have specimens from Rapallo (N. Italy), and Victoria (Australia), in which the large avicularia are broadly ligulate, while the small avicularia are oval and have rounded ends. In all cases, the avicularium on one side is large, on the other small, and the name *inæqualis*, which I gave to the Neapolitan specimen, calls to mind the most important character.

Loc. Living : Vineyard Sound and Long Island Sound (V.) ; Africa (H.) ; Victoria Bank, S.E. Brazil, 32 fath. (Ridley) ; Victoria, Bass's Straits (Hincks) ; Naples and Rapallo (Waters). Fossil : English Crag (W.) ; Bairnsdale (Gippsland), River-Murray Cliff (South Australia) ; Waipukurau, Napier, and Tommy Gully (New Zealand).

33. *MUCRONELLA PRÆSTANS*, Hincks.

Mucronella præstans, Hincks, Ann. & Mag. Nat. Hist. ser. 5, vol. x. p. 99, pl. vii. fig. 1.

Mucronella duplicata, Waters, Quart. Journ. Geol. Soc. vol. xxxvii. p. 328, pl. xvi. fig. 54, and vol. xxxviii. p. 266.

The fossils from Waipukurau are surrounded with large pores, as in the Curdies-Creek specimen, and some cells have similar avicularia, but they do not occur in all. My *M. duplicata* was described from a fragment of only a few cells, and although I also referred to a recent specimen sent over by Mr. Hutton as *Lepralia variolosa*, and gave particulars, it may, perhaps, be best to break the rule concerning priority and adopt Mr. Hincks's name.

This is allied to *M. coccinea*, but differs in the larger ovicell, which is not recumbent.

Loc. Living: New Zealand. Fossil: Curdies Creek (S.W. Victoria); Mt. Gambier in *Vincularia*-stage; Waipukurau, Petane marls.

34. *MUCRONELLA PEACHII*, Johnst.

This occurs fossil from Napier and probably the other localities; but in the fossils it is very difficult to always distinguish between this and the following variety, which is common.

35. *MUCRONELLA PEACHII*, var. *OCTODENTATA*, Hincks.

Mucronella Peachii, var. β . *octodentata*, Hincks, Brit. Mar. Polyzoa, p. 361, pl. li. fig. 2.

Mucronella teres, Hincks, Ann. & Mag. Nat. Hist. ser. 5, vol. viii. p. 65, pl. ii. fig. 5.

Mucronella spinosissima, Hincks, loc. cit. pl. iii. fig. 2.

? *Mucronella ventricosa*, var. *multispinata*, Busk, 'Challenger' Report on the Polyzoa, p. 160, pl. xxii. fig. 11.

? *Mucronella levis*, MacGillivray, Trans. Roy. Soc. Victoria, vol. xix. p. 136, pl. iii. fig. 16.

Lepralia arrecta, Rss. Bry. Cest. Ung. Mioc. p. 24, pl. ii. fig. 11.

This is a common fossil from Waipukurau. The zoarium is adnate, with distinct, raised, ovate, smooth zoecia; peristome raised all round, with about eight spines on the upper part, and a broad flat denticle in the oral aperture directed downwards (towards the neural wall); this denticle closes about one third of the aperture. Usually a row of pores round the border of the zoecium. Ovicell small, globular, smooth, recumbent.

Perhaps this should be called *M. Grotriana*, Stol. (see Reuss, Fauna Sept. p. 57, pl. vii. fig. 1; Denkschr. Ak. Wissensch. vol. xxv. p. 173, pl. vii. fig. 1), which only differs in the absence of spines. *L. Hörnesi*, Reuss, is also closely allied.

Loc. Living: Shetland (*A. M. N.*); Capri (*A. W. W.*); Curtis Island (*H.*); Station 148, and Prince Edward's Island, 80-120 fath. (*B.*); New Zealand species sent by Miss Jelly. Fossil: Waipukurau, Trig's Station (Tanner's Run), and Napier (N. Zealand).

36. *MUCRONELLA*? *ALVAREZIANA*, d'Orb. (Pl. VII. figs. 24, 25.)

Escharina alvareziana, d'Orb. Voyage dans l'Amérique, t. v. p. 14, pl. vi. figs. 1, 4.

Lepralia alata, Busk, Cat. Mar. Polyzoa, p. 71, pl. lxxix. fig. 3.

Mucronella alvarezii, Jullien, "Bry. Cheil." Bull. Soc. Zool. 1881, p. 5.

Two specimens from Waipukurau have subhexagonal zoëcia, with radiating grooves on the front and a very prominent umbo in the centre, a small avicularium or vibraculum on each side about the middle; a row of large pores round the edge of the zoëcium situated between the grooves. Above the oral aperture 4-6 spines. Oral aperture about 0.1 mm. wide, rounded on the distal edge, nearly straight below, forming a semicircle; the lower edge is minutely serrated, with three small teeth in the centre; on each side of the aperture a denticle directed inwards.

This differs from *L. alata*, as described by Busk, in the number of spines, and his description leaves us in doubt as to the aperture; and merely from the fossil it is impossible to be quite sure as to the genus. As *Lepralia alata* has never been returned to the British Museum, I have been unable to make a direct comparison.

Loc. Cape Horn, 40 fath. (*B.*); Peru (*d'O.*); Valparaiso (*J.*). Fossil: Waipukurau, Trig's Station, and "Whakati."

37. *MUCRONELLA TRICUSPIS*, Hincks.

Mucronella tricuspis, Hincks, Ann. & Mag. Nat. Hist. ser. 5, vol. viii. p. 66, pl. iii. fig. 1.

Mucronella munita, MacGillivray, Trans. Roy. Soc. Victoria, vol. xix. p. 136, pl. ii. fig. 10.

A specimen from Petane has a row of pores round the edge, and the peristome rises less suddenly out of the zoëcium than in my recent specimen. There are lateral acute avicularia, the ovicell is recumbent, and the fossil most nearly corresponds with MacGillivray's figure.

Loc. Living: Curtis Island (*H.*); Port Phillip Heads and New Zealand (*MacG.*). Fossil: Petane.

38. *MUCRONELLA TRICUSPIS*, Hincks, var. *WAIPUKURENSIS*, nov. (Pl. VIII. fig. 30.)

There is a worn fossil from Waipukurau, which, upon comparison with *M. tricuspis*, Hincks, turns out to be of the same size, and corresponds with it in the screen-like elevation, in both cases enclosing two tubes, as mentioned on page 59. In the fossil, however, the slender lateral mandibles are wanting; but there have been small and apparently nearly round avicularia near the base of the zoëcia.

39. *MUCRONELLA POROSA*, Hincks, var. *MINIMA*, nov. (Pl. VIII. fig. 31.)

A fossil from Petane has the upper part of the zoëcium thickened

and raised, and below this large pores on the surface of the zoëcia. There is a raised suboral avicularium directed laterally, and sometimes also a small round avicularium at the side of the aperture. Ovicell almost concealed in the zoëcium above. The oral aperture is about 0.16 mm., whereas in recent specimens of *M. porosa* from Port Phillip it is 0.33 mm.

40. *MUCRONELLA* (?) *LIVERSIDGEI*, T.-Woods.

Eschara Liversidgei, T.-Woods, Some Tert. Australian Polyzoa, Roy. Soc. of N.S.W. 1876, p. 3, figs. xi., xii., xiii.

A fossil from Waipukurau has the proximal edge of the aperture nearly straight, the distal rounded, and a little distance down the aperture there is a semicircular ridge which almost divides it into two parts. This, I believe, is the lower edge of the concealed ovicell, as we sometimes see it in *Cellaria*.

Just below the oral aperture there is a much raised protuberance, and on each side of this a large semicircular pore; below the protuberance there is a large round pore, below which, again, there is usually a small one, which may be elongate.

Loc. Fossil: Mount Gambier (*Woods*), Waipukurau.

41. *MUCRONELLA* *FIRMATA*, sp. nov. (Pl. VII. fig. 20.)

Zoarium adnate. Zoëcia broadly ovate, distinct, raised, coarsely punctured over the entire surface. Orifice almost semicircular, with a square tooth on the lower margin; peristome forming a broad thickened border round the upper part of the orifice, and thickened at each side near the base.

This differs from *Phylactella labrosa*, B., in having no raised peristome below the mouth.

Loc. Fossil: Napier and Waipukurau.

42. *SMITTIA* *RETICULATA*, MacG.

A badly-preserved *Smittia* from Whakati seems to be *S. reticulata*.

43. *SMITTIA* *LANDSBOROVII*, Johnst.

Lepralia Landsborovii, Johnst. Brit. Zooph. ed. 2, p. 310, pl. liv. fig. 9.

Loc. Living: Arctic and British seas, Mediterranean, Australia. Fossil: River Murray Cliffs (Australia); Petane (New Zealand).

44. *SMITTIA* *BIINCISA*, Waters, var. *BICUSPIS*, Hincks.

Mucronella bicuspis, Hincks, Ann. & Mag. Nat. Hist. ser. 5, vol. xi. p. 110, pl. vii. fig. 2.

The fossil from Mount Gambier (Quart. Journ. Geol. Soc. xxxviii. p. 272, pl. vii. fig. 1) has the avicularia more raised and has more large pores; but I have a recent specimen from New Zealand with more pores than Mr. Hincks figured, and with the avicularia more raised. The denticle ranges from being deeply cleft to being expanded and nearly flat at the tip.

In the important characters the two are unmistakably allied,

and it is with some hesitation that I make a variety of the New-Zealand fossil and recent specimens.

Loc. Living: New Zealand. Fossil: Waipukurau.

45. *SMITTIA NAPIERII*, Waters.

Smittia Napierii, Waters, Quart. Journ. Geol. Soc. vol. xxxix p. 438, pl. xii. fig. 14.

It has been thought that this was the *Mucronella tricuspis* of Hincks (Ann. & Mag. N. Hist. ser. 5, vol. viii. p. 66, pl. iii. fig. 1), and at one time I concurred in this view, which was based upon the examination of a specimen which Mr. Hincks himself had named *M. tricuspis*; but having since found a recent *tricuspis* from Port Phillip, Victoria, I see that they are not identical.

The recent *S. Napierii* has a solid shell, with large pores round the border; the avicularian mucro is directed mostly forwards, that is towards the distal end, and below this there is a narrow bifid denticle. The ovicell is sometimes nearly concealed, and its presence is only revealed by a mucronate elevation, in other cases it is considerably raised and globose.

The *M. tricuspis*, which has also been described as *M. munita*, MacGillivray (Desc. of New or Little-known Polyzoa, pt. 2, p. 136, pl. ii. fig. 10), has a very curious peristome which rises abruptly from the front of the zoecium and is thick in consequence of being hollow, or rather having a tube on each side of the mucro. This has not been mentioned by Mr. Hincks. Inside the peristome there is no denticle, but the proximal edge of the aperture is a straight plate. My specimen is hyaline.

Loc. Living: Port Phillip (Australia). Fossil: Wauru Ponds (Australia); Napier, Waipukurau; Trig's Station, Tanner's Run, N.Z.

46. *PORINA GRANDIPORA*, sp. nov. (Pl. VII. fig. 23.)

Although the state of preservation of this fossil from Napier is so unsatisfactory that a full description of it is impossible, yet, if again found, it may, I think, be recognized. The peristome is much raised, hiding the mouth, and there seems to have been a large avicularium on the summit at each side. In the centre of the zoecium there is a large round pore, and from this it would seem to belong to *Gigantopora* of Ridley.

47. *LEPRALIA POISSONII*, Aud. (Pl. VIII. fig. 37.)

Flustra Poissonii, Aud., Savigny, Descr. de l'Egypte, pl. x. fig. 5.

Lepralia Poissonii, Hincks, Ann. & Mag. Nat. Hist. ser. 5, vol. viii. p. 63, and vol. xv. p. 256.

Lepralia setigera, MacGillivray (non Smitt), Trans. Roy. Soc. Victoria, vol. xix. p. 133, pl. i. figs. 2, 3.

Lepralia odontostoma, Rss. Bry. Œst. Ung. Mioc. p. 16, pl. iv. fig. 8.

Lepralia Kirchenpaueri, var. *teres*, Hincks, Ann. & Mag. Nat. Hist. ser. 5, vol. vi. p. 77, pl. ix. figs. 7, 7a.

This is a very common fossil from Waipukurau and corresponds in

size with recent specimens from New Zealand, in which the front surface is smooth, and the small smooth ovicell has a mucronate ridge down the centre.

In recent specimens the spines do not occur in all zoecia nor in all specimens. The most spinous specimen that I have seen is one from Tahiti, in Miss Jelly's collection. This is nearly related to *Lepralia adpressa*, and I still adhere to my opinion that *L. Kirchenpaueri*, Heller, is only *L. adpressa*, in which, as I pointed out and figured in my paper on the Bryozoa from Naples (Ann. & Mag. N. H. ser. 5, vol. iii. p. 42, pl. xv. fig. 13), there are sometimes "lateral bosses." The best figure of *L. Kirchenpaueri* is given by Manzoni (Supp. alla Fauna dei Bry. Medit. p. 8, tav. iii. fig. 3).

The characters of the opercula of *L. Poissonii* and *L. adpressa* (figs. 37, 38) enable these to be readily distinguished, although also showing a near relationship. In the fossil some cells have the central mucro very prominent and in others it is entirely absent.

Loc. Living: Bass's Straits, Tahiti and New Zealand (*H.*); Port Phillip Heads (*MacG.*). Fossil: Napier and N. Harbour; Waipukurau, "Whakati," and Petane; Shakespeare Cliff (New Zealand); Miocene; Rauchstallbrunngraben, near Baden.

48. *LEPRALIA RECTILINEATA*, Hincks. (Pl. VII. fig. 16; Pl. VIII. figs. 34, 35, 36.)

Lepralia rectilineata, Hincks, Ann. & Mag. Nat. Hist. ser. 5, vol. xi. p. 110, pl. vii. fig. 5.

In a specimen from Waipukurau there is often a small ridge or boss at each side of the aperture, just below which there are two small avicularia, usually near together. Where the aperture is contracted there is a curved denticle directed inwards, and there is a similar one in *L. Dornii*, Kirchenpauer (MS.), from Naples. A specimen from Wanganui has large, elongate avicularia above the aperture, whereas there are none in the one from Waipukurau.

The ovicell, which is not known in the recent form, is raised, globular, about half as wide as a zoecium. Oral aperture 0.18 millim. at widest part.

Loc. Living: New Zealand. Fossil: Waipukurau, Wanganui, Napier.

49. *LEPRALIA IMBELLIS*, Busk.

Hemeschara imbellis, Busk, Crag Polyzoa, p. 78, pl. iv. fig. 6, pl. x. fig. 7.

Eschara pertusa, M.-Edwards, "Obs. sur les Foss. du genre Eschare," Ann. des Sc. Nat. ser. 2, vol. vi. p. 9, pl. x. fig. 3; S. Wood, Ann. Nat. Hist. vol. xiii. p. 16; Busk, Crag Polyzoa, p. 65, pl. x. fig. 2.

As *Lepralia pertusa*, Esper, was described before Milne-Edwards published the present species, the specific name must be changed; and seeing that Busk found it in the Crag, in both the *Eschara*- and the *Hemeschara*-stage, we can take his second name. The fossil from near Napier is adnate, and has elongate cells with large punctures over the surface. There are no ovicells on these fossils. Without

the avicularium this would be *Lepralia delicatula*, Manzoni (Bry. foss. Ital. 3a cont. p. 11, pl. iii. fig. 17).

There are also fossils from Napier, Petane, and Tommy Gully, with shorter cells and large pores arranged in a more or less radiating manner, and in appearance and size much the same as *Lepralia striatula*, Hincks, which I think cannot be regarded as more than a variety of the present. In a specimen of recent *L. striatula* sent me by Miss Jelly there are only two or three zoecia with avicularia at the side of the orifice. In none of the fossils do I find any, but it is possible that some cells that are partly broken-down may have had such avicularia. A fossil from Waipukurau Gorge has rather short cells with but few pores irregularly arranged. Close allies are *Lepralia regularis*, Rss., *L. circumornata*, Rss., and *L. megalota*, Rss., from the Austrian Miocene, and the living *L. Pallasiana* and *L. pertusa*, Esp.

Loc. Fossil: Crag, Sudbourne (*M.-Ed.*); C. Crag (*B.*); Zanclean of Calabria (*Sequenza*). Pliocene: Rametto (Sicily); Gerace, and Tenda del Prado (Calabria) (*A. W. W.*); Napier (N. Z.), and the short variety from Napier, Petane, Tommy Gully, and Waipukurau.

50. LEPRALIA PERTUSA, Esper.

Cellepora pertusa, Esper, Pflanz. Cellep. p. 149, pl. x. fig. 2.

Lepralia pertusa, Busk, B. M. Cat. p. 80, pl. lxxviii. figs. 1 & 3 (non 2), pl. lxxix. figs. 1, 2; Smitt, Floridan Bry. p. 55; Hincks, Brit. Mar. Polyzoa, p. 305, pl. xliii. figs. 4, 5.

Lepralia pertusa, var. *rotundata*, Waters, Ann. & Mag. Nat. Hist. ser. 5, vol. iii. p. 31.

Loc. Living: European seas, Florida, Australia (?); New Zealand (?). Fossil: Muddy Creek; Waurn Ponds (Austr.); Napier (N.Z.).

51. LEPRALIA ROSTRIGERA, Sm. (Pl. VII. fig. 17.)

Escharella rostrigera, Smitt, Floridan Bryozoa, p. 57, pl. x. figs. 203-205.

Lepralia rostrigera, Waters, Quart. Journ. Geol. Soc. vol. xli. p. 298.

The specimen from Napier is larger than the recent Floridan examples, or the fossil from the River-Murray Cliffs. It is adnate, and the zoecia are divided by raised lines; the surface is punctured and granulated; the oral aperture is 0.22 millim., with an avicularium at each side of the aperture. There is a raised border round the aperture.

This is allied to *Lepralia ingens*, Manzoni (Castrocaro, p. 25).

Loc. Living: Florida. Fossil: R.-Murray Cliffs (Australia); Napier (N. Zeal.).

52. LEPRALIA LONGIPORA, MacGillivray.

Lepralia longipora, MacGillivray, "Descript. of New or Little-known Polyzoa," pt. ii., Trans. Roy. Soc. Vict. vol. xix. p. 135, pl. iii. fig. 18.

Cyclicopora praelonga, Hincks, Ann. & Mag. Nat. Hist. ser. 5, vol. xiv. p. 279, pl. ix. fig. 7.

The fossil from Waipukurau has the upper part of the zoecium raised, giving a tubular appearance to the peristome. The surface is granular and has more punctures than are figured by MacGillivray. The ovicell is narrower than a zoecium. In *Mucronella canalifera*, Busk, the peristome is much produced and the ovicell is smaller.

Loc. Living: Port Phillip Heads (Victoria). Fossil: Waipukurau and Trig's Station.

53. LEPRALIA SEMILUNA, Rss., var. SIMPLEX, nov. (Pl. VII. fig. 19.)

Eschara semiluna, Rss. "Die Foram. Anth. und Bry. des deutschen Septar." p. 182 (66), pl. vi. fig. 6, Denkschr. k.-k. Akad. Wissensch. Wien, vol. xxv.

A fossil from Napier is adnate. The zoecium is suboval, only slightly convex, with rather large pores. Oral aperture elongate, straight below and with the sides straight, curved above. Walls at the side of the aperture thickened, forming a kind of peristome. Above the aperture a nearly concealed ovicell with an oval cribriform depression in the middle.

I am unable to find any suboral avicularia, as described by Reuss, and therefore call it var. *simplex*.

The species is described from Söllingen.

54. LEPRALIA FORAMINIGERA, Hincks.

Lepralia foraminigera, Hincks, Ann. & Mag. Nat. Hist. ser. 5, vol. xi. p. 109, pl. vii. fig. 1.

The fossil, though there are only the two upper openings, corresponds with recent specimens; the oral aperture, in each case, is about 0.15 millim. in diameter, and the operculum has a characteristic hinge-projection on each side, which Mr. Hincks seems to have overlooked.

Loc. Fossil: Waipukurau. Living: New Zealand (*H.*); Napier (sp. sent by *Miss Jelly*).

55. LEPRALIA BISTATA, sp. nov. (Woodcut, fig. 1.)

Zoarium incrusting. Zoecia distinct, convex, surface perforated and mamillated. Oral aperture coarctate, with a small denticle at each side where the contraction takes place. Ovicell small, subimmersed, about half the width of a zoecium, and the ovicelliferous cells have a very much wider oral aperture than the other zoecia and an extraordinarily thick lower lip. The zoecia and aperture are about the same size as those of *L. Pallasiana*.

Loc. Waipukurau Gorge.

56. PORELLA MARSUPIUM, MacG.

Porella marsupium, Waters, Quart. Journ. Geol. Soc. vol. xxxix. p. 437.

Loc. Living: Victoria (*MacG.*); Bass's Straits (*H.*). Fossil: Wairn Ponds (Victoria); Waipukurau (New Zealand).

57. *PORELLA MARSUPIUM*, var. *PORIFERA*, Hincks.

Porella marsupium, MacG., form *porifera*, Hincks, 'Ann. & Mag. Nat. Hist. ser. 5, vol. xiii. p. 24, pl. iv. fig. 4.

Loc. Living: Queen Charlotte Island, off British Columbia (*H.*).
Fossil: Waipukurau and Napier (New Zealand).

58. *PORELLA CONCINNA*, Busk.

Porella concinna, Waters, Quart. Journ. Geol. Soc. vol. xxxviii. p. 271.

An incrusting fossil from Tommy Gully, Petane, has the avicularium much raised on a suboral prominence, and in this respect differs from the European types. The zoecia are divided by raised lines, and the surface has large pores.

Loc. Living: European seas; Bass's Straits. Fossil: Mount Gambier; Tommy Gully (Petane).

Fig. 1.—*Lepralia bistata*, Waters, from Waipukurau, New Zealand.

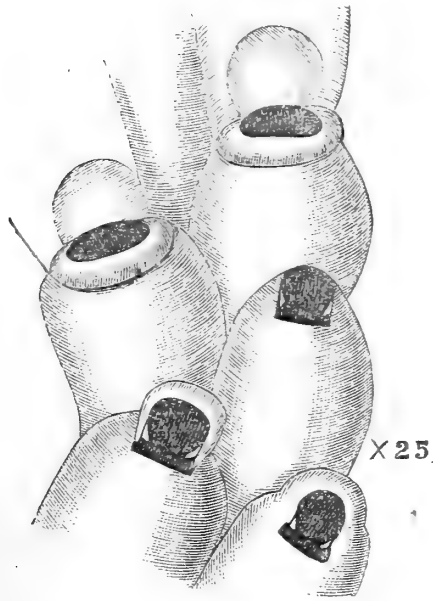
59. *HIPPOTHOA FLAGELLUM*, Manz.

Hippothoa flagellum, Manz. Bry. Foss. Ital. 4a cont. p. 6, pl. i. fig. 5; Suppl. alla Fauna dei Bry. Medit. 1a cont. p. 3; Bri. del Plioc. antic. di Castrocaro, p. 5, pl. i. fig. 14; Hincks, Ann. & Mag. Nat. Hist. 1877, vol. xx. p. 218; Brit. Mar. Polyzoa, p. 293, pl. xlv. figs. 5-7; Busk, Chall. Rep. Polyzoa, p. 4, pl. xxxiii. fig. 7.

Probably also *Terebripora ramosa et irregularis*, d'Orb. Voy. dans l'Amér. Mérid.

Loc. British seas and Medit.; Singapore (*H.*); Heard Island, 75 fath.; New Zealand. Fossil: Pliocene of Italy and Sicily; Napier.

60. SCHIZOPORELLA CIRCINATA, MacG. (Pl. VIII. fig. 41.)

Lepralia circinata, MacG., Nat. Hist. Victoria, dec. iv. p. 21, pl. xxxv. fig. 1.

Schizoporella circinata, Busk, 'Challenger' Rep. of Polyzoa, p. 166, fig. 46; Hincks, Ann. & Mag. Nat. Hist. ser. 5, vol. xv. p. 253, pl. vii. fig. 1.

This is a common fossil from Waipukurau, and in size is just the same as recent specimens from Napier. The long spatulate avicularium, directed downwards, is usually present; the oral aperture (0·07 millim.) is about half the size of that of *S. Cecilioi*, Aud. Mr. Busk describes in both of these a movable appendage jointed to the operculum: but neither of them is figured correctly by him, as in *S. Cecilioi* the appendage is a broad plate below the operculum, and does not become narrower, as may be seen in the figure given in my paper "On the Use of the Opercula" &c. (Proc. Manch. Lit. & Phil. Soc. xviii. 1878, fig. 1), and in *S. circinata* it becomes broader below; and this appendage separates very readily from the rest of the operculum, so that it is difficult to prepare them out together. In both there is a small notch in the proximal edge of the larger piece of the operculum, into which the appendage fits; in *S. circinata* it is very minute, but in *S. Cecilioi* is much more pronounced. It does not seem that this appendage is movable, but that an integument is attached both to it and to the proximal edge of the operculum. In neither have I been able to find the minute fasciculus of muscular fibres at the lower part of the appendage to which Mr. Busk refers, and such a structure would be very inexplicable.

Loc. Living: Victoria (MacG.); off Inaccessible Island, Tristan d'Acunha (*Chall. Exp.*); Napier (*Miss J.*). Fossil: Waipukurau.

61. SCHIZOPORELLA AURICULATA, Hass.

Loc. Living: European and Australian seas. Fossil, Pliocene: Brucoli (Sicily); Reggio (Calabria); Mount Gambier and Bairnsdale (Australia); Napier and Tommy Gully (New Zealand).

62. SCHIZOPORELLA RIDLEYI, MacG.

Schizoporella marsupium, Ridley, Zool. Coll. made by H.M.S. 'Alert,' Proc. Zool. Soc. 1881, p. 48, pl. vi. fig. 6.

Schizoporella Ridleyi, MacGillivray, Trans. Roy. Soc. of Victoria, vol. xix. p. 191, pl. i. fig. 1.

This is a very small species, with the aperture only 0·6 millim. wide. In the fossil the prominent suboral avicularia cover a large part of the zoecium.

This seems to be closely allied to *S. auriculata*, but is smaller. Mr. Hincks (Ann. & Mag. N. Hist. ser. 5, vol. xiii. p. 25) thinks that this is identical with *S. (Escharina) simplex*, d'Orb.; but Mr. Quelch, who has since examined original specimens of *S. Ridleyi*, combats this (Ann. & Mag. N. Hist. ser. 5, vol. xiii. p. 215). I am not quite convinced that this should not be united with *S. simplex*, d'Orb.; but as there is a doubt, it will be best to retain the other name.

Loc. Living: Elizabeth Island, 6 fath. (*R.*); Victoria (*MacG.*).
Fossil: Waipukurau; Napier (?).

63. SCHIZOPORELLA MARSUPIFERA, Busk.

Schizoporella marsupifera, Busk, 'Challenger' Report on the Polyzoa, pt. xxx. p. 165, pl. xxii. fig. 14.

Schizoporella lineolifera, Hincks, Ann. & Mag. Nat. Hist. ser. 5, vol. xvii. p. 267, pl. ix. fig. 10.

Loc. Living: Marion Island, 50-75 fath.; Station 167, off New Zealand, 150 fath. (*B.*); Adriatic (*H.*); Port Jackson, Sydney (*A. W.*). Fossil: Waipukurau.

64. SCHIZOPORELLA BIAPERTA, Mich.

Eschara biaperta, Mich. Icon. Zooph. p. 330, pl. lxxix. fig. 3 (see Hincks, Brit. Mar. Poly. p. 255, pl. xl. figs. 7-9); Waters, Ann. & Mag. Nat. Hist. ser. 5, vol. iii. p. 37, pl. xi. figs. 1 & 2.

Loc. Living: European seas, Florida, Madeira, Tartary, Columbia, New Zealand (*A. W. W. coll.*), Bass's Straits. Fossil: Doué (Miocene); Crag; Pliocene of Italy and Sicily; Waipukurau.

65. SCHIZOPORELLA CRIBRILIFERA, Hincks.

Schizoporella cribrilifera, Hincks, Ann. & Mag. Nat. Hist. ser. 5, vol. xv. p. 250, pl. viii. fig. 5.

The fossil from the Petane marls is adnate, with the cells irregular, as in *Cellepora*, and the aperture deep down, of the same size and shape as in the recent species, but apparently without avicularia.

Loc. Living: New Zealand. Fossil: Petane marls.

66. SCHIZOPORELLA CLAVULA, Manz.

Lepralia clavula, Manzoni, Bry. Foss. Ital. cont. 3a, p. 8, pl. ii. fig. 9.

In the fossil from Waipukurau there are six spines above the aperture, and the ovicell is small, erect, somewhat elongate. At one or both sides of the aperture there is a narrow avicularium directed distally, following the border of the aperture, and usually curved. The surface has probably been papillated, but that cannot be made out with certainty.

Loc. Fossil: Turin (Miocene); Waipukurau.

67. SCHIZOPORELLA CONSERVATA, Waters. (Pl. VII. fig. 21.)

Schizoporella conservata, Waters, Quart. Journ. Geol. Soc. vol. xxxvii. p. 340, pl. xviii. fig. 81, and Q. J. G. S. vol. xxxviii. p. 273, pl. vii. fig. 7; Hincks, Ann. & Mag. Nat. Hist. ser. 5, vol. x. p. 96, pl. vii. fig. 2, and vol. xiv. p. 281.

Schizoporella insignis, MacGillivray (non Hincks), Trans. Roy. Soc. Vict. vol. xix. p. 132, pl. ii. fig. 11.

I could not for some time decide whether the fossils from Curdies Creek and Mount Gambier, the recent forms from near Melbourne, and the fossil from Napier should be united under the same species,

seeing that while certain important characters show that they are closely allied, in other points there are differences which may be varietal. The oral aperture of the New-Zealand fossil has a narrow sinus and is 0·2 millim. wide, which is larger than in the Australian fossils, but not so large as in the recent examples, in which it is 0·32 millim. wide and has a much larger and rounder sinus.

In both the recent specimens and the New-Zealand fossil the ovicell is more concealed than in the fossil first described, and in both there is a row of pores round the flat central part inside the ridge. In fact, in one specimen from Napier the ovicell is quite on a level with the zoecium, and only the ridge and row of pores is visible. These pores are not mentioned by Mr. Hincks in his description, but occur in a recent specimen from Port Western. In the Napier fossil the avicularia are smaller and more raised than in the others, and there is usually only one avicularium to a zoecium; the centre of the zoecium is plain with large pores round it, whereas in the recent examples there is no plain portion, but there is in one a ridge up the centre as first described. The ovicell of the New-Zealand fossil is so much concealed that I am not sure whether there have been radiating lines on its walls.

The affinities and differences of these three varieties, separated as they are in time and locality, are very interesting.

Loc. Living: Port Phillip, Port Phillip Heads, and Port Western (Adelaide). Fossil: Curdies Creek (S.W. Australia), Mount Gambier (S. Australia), and Napier (New Zealand).

68. SCHIZOPORELLA OBLIQUA, (?) MacG. (Woodcut, fig. 2.)

Eschara obliqua, MacGillivray, Austr. Polyz., Trans. Roy. Soc. Viet. vol. ix. p. 137 (1868); Zool. Vict. decade v. p. 39, pl. xlviii. fig. 1.

An adnate specimen, from Waipukurau Gorge, has zoecia sur-

Fig. 2.—*Schizoporella obliqua* (?), MacG., from Waipukurau, New Zealand.

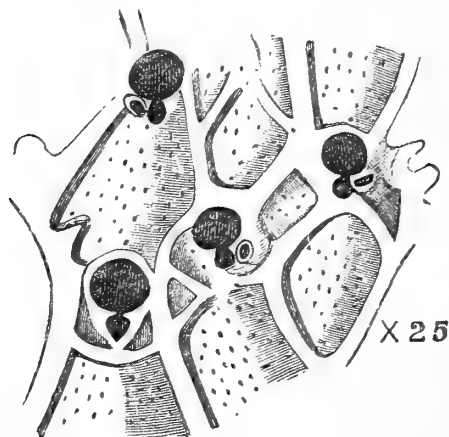

rounded by raised smooth lines, and also frequently a raised line across, or partly across, the zoecium below the aperture, and there

is sometimes at the side of the sinus a small suboral avicularium, so that the fossil differs in these two particulars from the typical *S. obliqua*. The sinus is very distinct, and the aperture almost meets above it.

69. SCHIZOPORELLA CINCTIPORA, Hincks, var. PERSONATA, nov. (Pl. VIII. fig. 28.)

Zoarium adnate. Zoecia ovate, not much raised, divided by slightly raised lines; surface reticulate, with large pores. Oral aperture rounded above, longer than broad, with a distinct sinus on the proximal edge; on each side, below the aperture, on the border of the zoecia, an elongate protuberance; between these, below the aperture, a small rounded avicularium. This differs from the recent forms in having the two lateral bosses. Since describing and figuring the first specimens, I have had another from Waipukurau Gorge, with ovicells, submitted to me. The two lateral bosses, in fully developed ovicelligerous cells, meet in front and form a bridge, as in *Smittia jacobensis*, *S. Landsborovii*, var. *personata*, *Microporella polystomella*, and *Schizoporella polymorpha*, B. In the Waipukurau fossils there are no avicularia. Miss Jelly has a specimen of this variety, recent, from New Zealand, growing in a cylindrical shape.

Loc. Living: New Zealand. Fossil: Petane marls and Waipukurau.

70. SCHIZOPORELLA TUBEROSA, Rss., var. ANGUSTATA, nov. (Pl. VIII. fig. 26.)

Type: *Eschara tuberosa*, Rss. Die Foram. Anth. und Bry. des d. Septarienthones, Denkschr. Ak. Wissensch. Wien, vol. xxv. p. 188, pl. vi. figs. 9, 10, pl. viii. fig. 1.

Schizoporella biturrita, Hincks, Ann. & Mag. Nat. Hist. ser. 5, vol. xiv. p. 280, pl. ix. fig. 8.

This occurs fossil from Waipukurau, with a tubular zoarium, in the Hemeschara-stage. Zoecia indistinct, with few large pores. Oral aperture clithridiate, with a large broad triangular avicularium above the aperture on each side directed towards the aperture. Oral aperture 0.17 millim. wide, 0.21 millim. long.

In mode of growth and general characters this resembles a recent *Schizoporella tuberosa* from the Semaphore, Adelaide, with a large triangular avicularium, which is often much raised, above the aperture on each side, and with a large broad raised ovicell; but in this the aperture is much larger and the sinus is broadly emarginate (see fig. 29).

In the fossil we are reminded of *Lunulites incisa*, H. (*conica*, MacG.), and *Schizoporella biaperta*. The typical *L. tuberosa* also occurs recent in Botany Bay, N.S.W., in the Lepralia-stage. Mr. Hincks describes it from Port Phillip Heads in a bilaminate stage.

I have not seen any from Australia or New Zealand with the avicularia inarching, *i. e.* in the *personata*-stage, as in Busk's *Gephyrophora polymorpha*.

71. SCHIZOPORELLA HYALINA, L. (Pl. VIII. figs. 42, 43.)

For synonyms, see Hincks, Brit. Mar. Polyzoa, p. 271, and add:—
Eschara annularis, Moll, Seerinde, p. 39, fig. 4.

I cannot agree with Mr. Busk in uniting this with *Chorizopora*, which has the proximal edge of the operculum straight, whereas in the ordinary zoecia of *S. hyalina* there is a wide sinus, and it is only in the fertile cells that the proximal edge is nearly straight (see figs. 42, 43). Mr. Busk identified what we now know as *Chorizopora Brongniartii*, Aud., with Savigny's figure of *Flustra Brongniartii*; and as this has been generally accepted it would not be advisable now to change the name, though I quite agree with Mr. Busk in doubting whether Savigny's figure was meant to represent the species.

Loc. Living: Cosmopolitan. Fossil: English Crag; Waipukurau and Tommy Gully, Trig's Station (New Zealand).

72. CELLEPORA ALBIROSTRIS, Sm.

Cellepora albirostris, Waters, Quart. Journ. Geol. Soc. vol. xli. p. 304.

A specimen from Shakespeare Cliff has a free globular form, about 6 millim. in diameter; two specimens from Napier are adnate on shell, while another is a large solid branching form. In none is the preservation very satisfactory, and no spines are seen, so that perhaps they should be called var. *hastigera*, B. The proximal edge of the oral aperture is more curved than in my recent specimens, and in this respect more resembles var. *hastigera*.

Loc. Living: Florida, 25–35 fath.; Sydney (*Sm.*); Shark Island, 8 fath. (*A. W.*); Heard Island, 75 fath. (*B.*); Adelaide (*A. W.*). Fossil: River Murray (Australia), Napier and Wanganui (New Zealand).

73. CELLEPORA TRIDENTICULATA, Busk.

Cellepora tridenticulata, Busk, Journ. Linn. Soc. vol. xv. p. 347; 'Challenger' Rep. on Polyzoa, p. 198, pl. xxix. fig. 3, pl. xxxv. fig. 17; Waters, Quart. Journ. Geol. Soc. vol. xli. p. 306.

The fossil from Waipukurau is adnate, and shows the attachment of the two spines very clearly.

Loc. Living: Cape York; Adelaide. Fossil: Aldinga; River-Murray Cliffs; Yorke's Peninsula (Australia); Waipukurau (New Zealand).

74. CELLEPORA CORONOPUS, S. Wood.

For synonyms, see Waters, Quart. Journ. Geol. Soc. vol. xli. p. 302.

A specimen from Napier occurs in a thick solid branching form. The minute characters are made out with difficulty.

75. CELLEPORA COSTATA, MacG.

Cellepora costata, MacGillivray, Trans. R. Soc. Vict. vol. ix. 1869, p. 136; Waters, Quart. Journ. Geol. Soc. vol. xli. p. 303.

Cellepora globularis, Bronn, Leth. Geogn. ii. p. 877, pl. xxxv.

fig. 15, *a, b*; Reuss, Foss. Polyp. des W. Tertiärbeckens, p. 76 pl. ix. figs. 11–15; Reuss, Foss. Fauna St. von Wieliczka, p. 94; Manzoni, Bri. foss. del Mioc. d'Aust. ed Ungh. p. 51, pl. i. fig. 2.

Cellepora retusa, Manzoni, Bri. del plioc. ant. di Castrocaro, p. 35, pl. v. fig. 59.

Cellepora retusa, Manz., var. *caminata*, Waters, Ann. & Mag. Nat. Hist. ser. 5, vol. iii. p. 194, pl. xiii. fig. 1.

Cellepora rota, MacGillivray, New or Little-known Polyzoa, pt. viii. p. 11, pl. iii. fig. 6.

There are two adnate convex zoaria, fossil, from Napier, about 12 millim. in diameter. In most zoecia the aperture is unarmed, though in a good many there is an avicularium at one side, and these cells exactly correspond with Manzoni's figure of *Cellepora globularis* (I Bri. Mioc. Aust. Ung. p. 51, pl. i. fig. 2); there are, however, a few zoecia with an oral avicularium at each side.

In some specimens of what I may call the typical *Cellepora globularis*, which I collected from the Miocene of Nussdorf, near Vienna, there are nearly always two lateral oral avicularia, but a few zoecia have only one, thus again corresponding with Manzoni's figure. When these Nussdorf specimens have the two avicularia, the appearance is just the same as in some cells of *C. retusa*, var. *caminata*, W., which, however, more frequently has three avicularia. We are thus able to trace the unbroken connexion between the New Zealand fossils, in which the aperture is nearly always unarmed, and the recent Naples form, in which there are usually three very prominent oral avicularia. In all cases the oral aperture is deep down in the peristome.

I have a recent specimen from Port Phillip Heads with long branches, seldom with oral avicularia, but when they occur the mandibles are semicircular. I had not at all recognized the similarity until I prepared out the opercula, which are characteristic and correspond with the Naples specimens. The apertures are larger than those of the fossils, which measure about 0.08 millim. In this Port-Phillip-Heads species there are large spatulate avicularia.

The connexion was thus independently traced up in the fossils by means of the oral avicularia, and in the recent forms by the opercula and other chitinous organs.

I have been in doubt as to whether this should be called *C. costata* or *globularis*; but as it is by means of direct comparison of typical specimens rather than by the descriptions that I have worked up the synonymy, the name *costata* is retained.

Loc. Living: Wilson Promontory and Queenscliff, Victoria (*MacG.*); Port Phillip Heads (*MacG. & A. W. W.*); Glenelg, S. Australia (*A. W. W.*); Naples (*W.*). Fossil: Nussdorf (*A. W. W.*) and numerous other Miocene localities of Austria and Hungary (*Reuss & Manz.*); Pliocene of Italy (*Manz. & W.*); Adelaide, Australia; Napier, New Zealand.

76. CELLEPORA DECEPTA, sp. nov. (Pl. VIII. fig. 33.)

There are two unsatisfactorily preserved specimens from Napier.

The lower edge of the aperture is straight, the upper rounded (0·1 millim. wide). There is an avicularium below the oral aperture, and the avicularian chamber is much raised, so that the appearance of these is sometimes almost like ovicells. The ovicells are usually much concealed. Vicarious avicularia elongate, spatulate, scattered all over the colony. This is related to *C. pertusa* and *C. fossa*.

CELLEPORA.

There is a cylindrical *Cellepora* from Napier with zoecia irregularly placed; the oral aperture subrotundate with a wide sinus. There are numerous avicularia scattered about, some are very large, being the length of three or four zoecia; the mandibular space is acute. It is distinguished from *C. yarraensis*, Waters, by the shape of the aperture.

77. RHYNCHOPORA LONGIROSTRIS, Hincks. (Pl. VII. fig. 22.)

Rhynchopora longirostris, Hincks, Ann. & Mag. Nat. Hist. ser. 5, vol. viii. p. 66, pl. iv. figs. 7, 8.

Fossil, from Napier, adnate. Zoecia elongate, rising towards the mouth with a very long raised avicularian rostrum. On some zoecia there is a very narrow avicularium attached to the rostrum, with the mandible directed towards the proximal part of the zoecium. The oral aperture is suborbicular, with a wide round sinus.

Rhynchopora bispinosa is a most variable species, and when it has been properly worked up will probably have the longest list of synonyms of any Bryozoon, and my first impression was that the fossil belonged to that species. Being unable, however, to find any denticles, and all the cells being equal in size without the peristome rising on either side, I referred the fossil to *Schizoporella*; but receiving a recent specimen from Port Phillip, Australia, in which the long rostrum was well developed, with a lanceolate avicularium to almost every cell, and a slight elevation of the peristome on each side, the species was again brought back to *Rhynchopora*. In the recent form I am able to see in one or two zoecia a small denticle, but cannot find one in most. This seems to be allied to *Cellepora longirostris*, MacG., and *Schizoporella cryptostoma*, MacG.

Loc. Living: Curtis Island (H.); Port Phillip (W.). Fossil: Napier.

78. LUNULITES PETALOIDES, d'Orb.

Lunulites petaloides, d'Orb., Waters, Quart. Journ. Geol. Soc. vol. xxxix. p. 442, pl. xii. fig. 11 a, b, c.

There are several specimens from Shakespeare Cliff, Wanganui, and in these the number of vibracula is very variable; they are often placed regularly for two or three rows, and in the rest of the colony scattered irregularly. The aperture is 0·4 millim. wide.

I do not see any reason for changing the generic name which has now been used for so long and is so generally recognized, nor is any advantage apparent in the alteration to *Lunaria* proposed by

Mr. Busk, and no one, however eminent, has authority to alter a well-established name. The genus, however, can only be looked upon as provisional, since it is almost entirely based on the mode of growth. This I have already shown to be unsatisfactory, and within the last few weeks have received from New South Wales a recent specimen of *Flabellopora elegans*, d'Orb., which is either *Lunulites cancellatus*, Busk, or very closely allied to it. This grows in an irregular sub-crescentic form with two layers of zoecia separated by a cellular structure formed of avicularian cells.

Loc. Fossil: European Cretaceous, Miocene and Pliocene; Mt. Gambier, Muddy Creek, Bird Rock (Australia); Napier and Wanganui (New Zealand).

Besides the species discussed, there are some specimens of *Retepora* from near Napier, and a *Caberea* from Waipukurau which may be the *C. crassimarginata* of Busk.

EXPLANATION OF PLATES VI.-VIII.

PLATE VI.

- Fig. 1. *Membranipora Lacroixii*, Aud., var. *grandis*. From Napier.
 2. ——— *annulus*, Manz.
 3. ——— *monostachys*. From Napier.
 4. ——— *Dumerilii*, Aud. From Waipukurau.
 5. ——— *annulus*, Manz. From the same specimen as fig. 2.
 6. ——— *monostachys*. From the same specimen as fig. 3. From Napier.
 7. ——— *nobilis*, Rss. From Petane.
 8. *Monoporella disjuncta*, Manz. From Napier.
 9. *Membranipora annulus*, Manz.
 10. ——— *nobilis*, Rss., with cells like *ovalis*. From Napier.
 11. *Monoporella waipukurensis*, sp. nov. From Waipukurau.
 12. *Membranipora occultata*, sp. nov., fossil. From Napier.
 13. ——— ———, recent.
 [14. Cancelled.]

PLATE VII.

- Fig. 15. *Monoporella crassatina*, Waters. Whakati.
 16. *Lepralia rectilineata*, Hincks. From Waipukurau.
 17. ——— *rostrigera*, Sm. From Napier.
 18. *Membraniporella nitida*, J. From Waipukurau.
 19. *Lepralia semiluna*, var. *simplex*, nov. From Napier.
 20. *Mucronella firmata*, sp. nov. From Waipukurau.
 21. *Schizoporella conservata*, Waters. Napier.
 22. *Rhynchopora longirostris*, Hincks. From Napier.
 23. *Porina grandipora*, sp. nov. From Napier.
 24. *Mucronella alvareziana*, B., $\times 25$. From Waipukurau.
 25. ——— ———, $\times 85$. Ditto.

PLATE VIII.

- Fig. 26. *Schizoporella tuberosa*, Rss., var. *angustata*. From Napier.
 27. *Micropora variperforata*, sp. nov.
 28. *Schizoporella cinctipora*, H., var. *personata*. From Petane.
 29. ——— *tuberosa*, Rss., recent. From Napier.
 30. *Mucronella tricuspis*, Hincks, var. *waipukurensis*; front of cells broken down.
 31. *Mucronella porosa*, H., var. *minima*. From Petane.
 32. *Membranipora spinosa*, Q. & G. From Napier.
 33. *Cellepora decepta*, sp. nov. From Napier.

- Fig. 34. Operculum of *Lepralia rectilineata*, $\times 85$.
35. Mandible of *Lepralia rectilineata*, $\times 250$.
36. ——— ———, $\times 85$.
37. Operculum of *Lepralia Poissonii*, Aud., $\times 170$.
38. ——— ——— *adpressa*, B., $\times 170$.
39. *Monoporella capensis*, var. *dentata*. From Napier.
40. Operculum of *Membranipora occultata*, sp. nov., $\times 250$.
41. Operculum of *Schizoporella circinata*, MacG., $\times 170$.
42 & 43. Opercula of *Schizoporella hyalina*, L., $\times 170$.

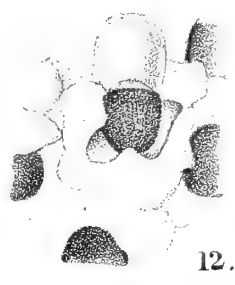
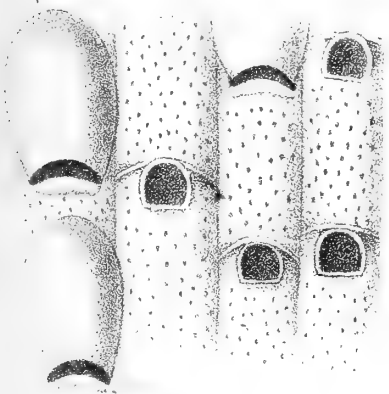
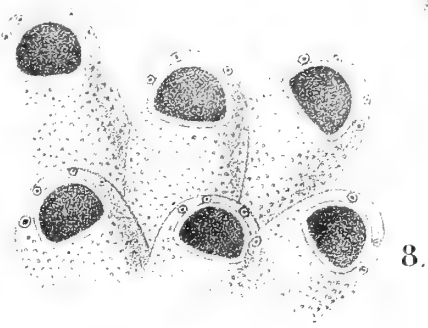
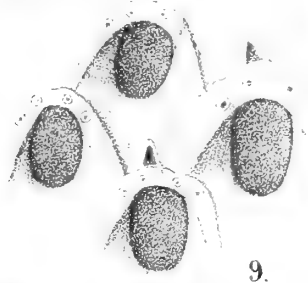
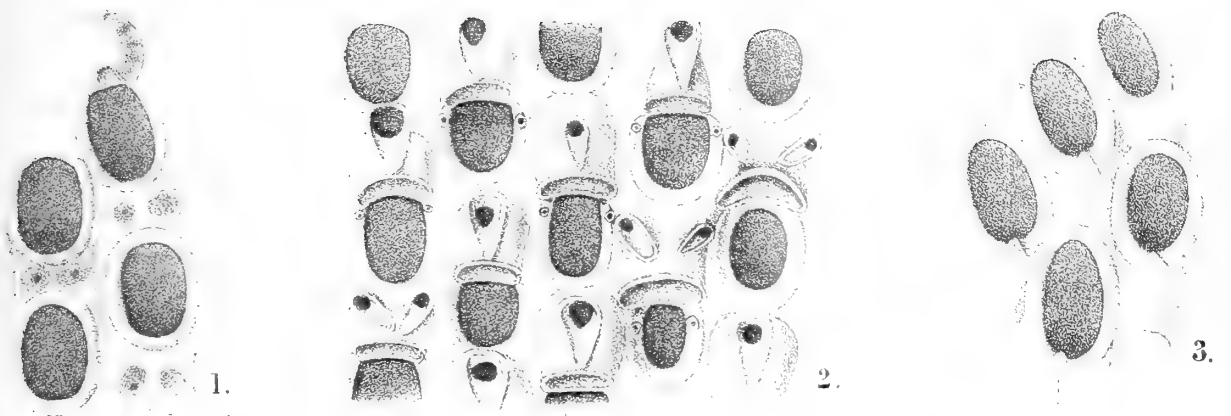

II.

13.



15.



16.

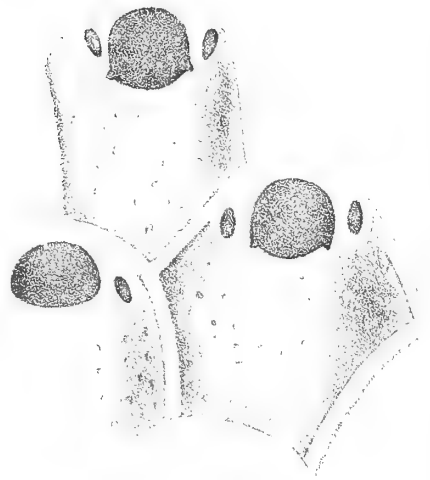

17.



18.



19.

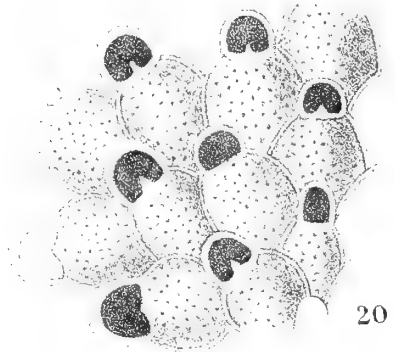

20.

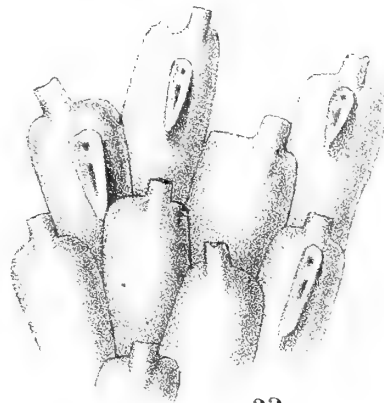

22.

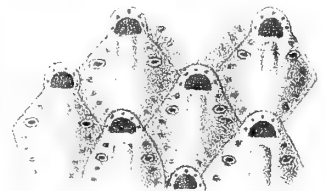

24.

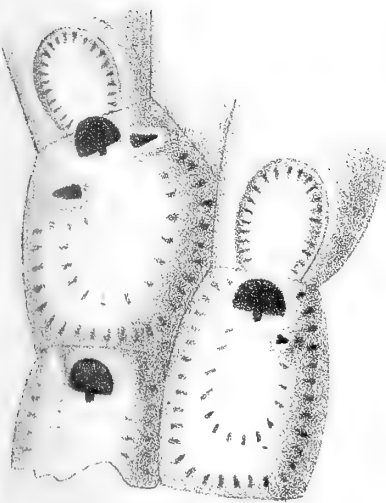

21.

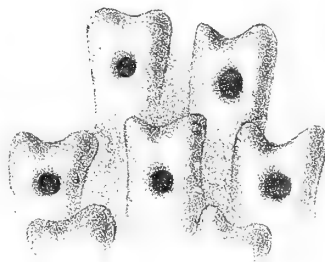

23.

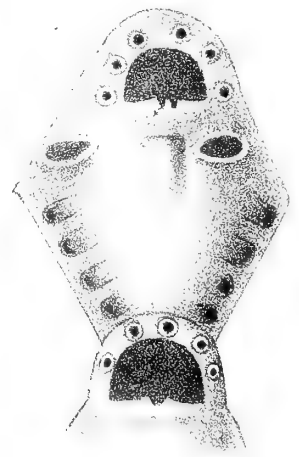

25.

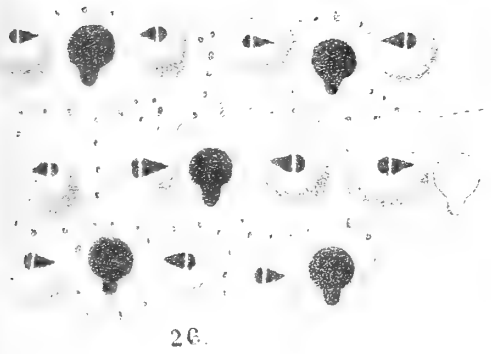

26.

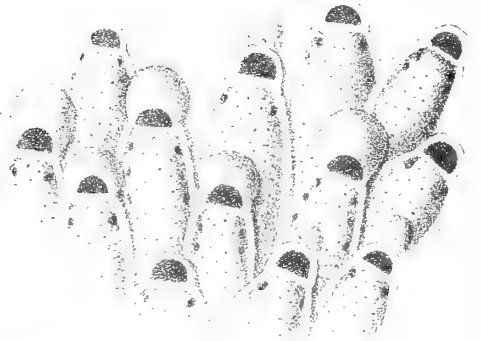

27.

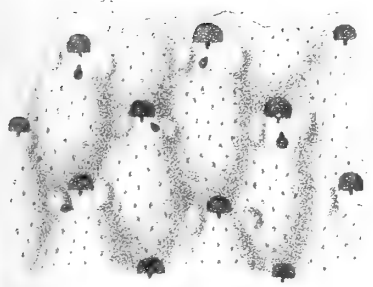

28.



29.

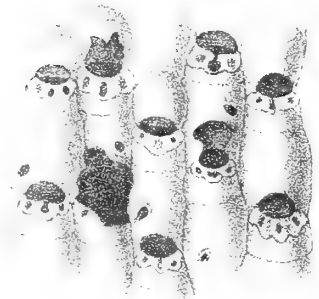

30.

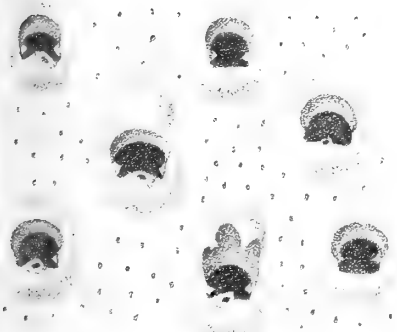

31.

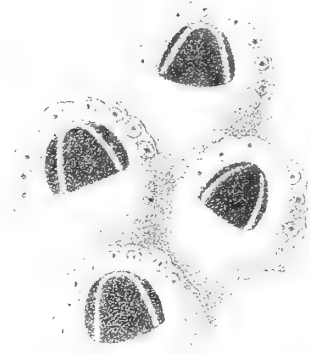

32.



33.



34.



35.



36.

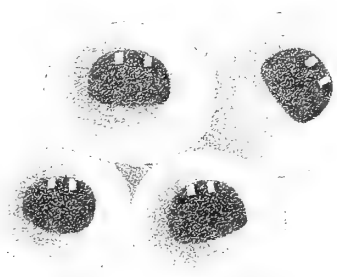

39.

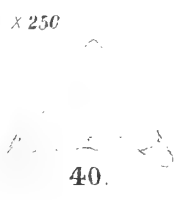

40.

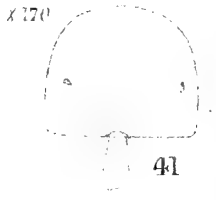

41.



37.



38.

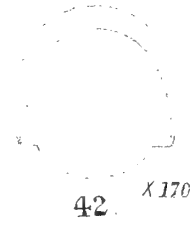

42.

X 170

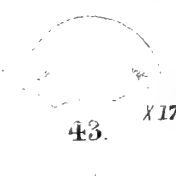

43.

X 170.



7. *On the DRIFTS of the VALE of CLWYD and their RELATION to the CAVES and CAVE-DEPOSITS.* By T. M^cKENNY HUGHES, M.A., F.G.S., Woodwardian Professor of Geology, Cambridge. (Read November 17, 1886.)

[PLATE IX.]

PART I.

Introduction.

THE questions here involved are many and various, and their consideration carries us from one place to another over a very wide area.

We cannot safely draw inferences as to the age and origin of any drifts on the borders of a mountain-land without, on the one hand, tracing it up to the source from which it was transported, to see whether we can explain the distribution of the various kinds of material of which it is composed, and, on the other hand, following it as far as possible down over the lowlands, to see whether any succession of deposits or organic remains or evidence as to its former extent can be made to throw light on the conditions of the age in which it was distributed.

And, seeing that most caves have been formed and filled during the age of accumulation of the various superficial deposits which we include under the name "drift," we cannot safely speculate upon the age or origin of the one set of phenomena without considering all the evidence to be derived from the other also.

Only in the hilly districts can we find caves at all, and, generally, the more important occur along the outskirts of the high lands, where drifts of various character are apt to be found. The relation of the local drifts to the caves may be of great interest if the exact place and age of those drifts have first been clearly made out.

We must first therefore inquire whether it is possible to establish a local succession in the drifts; whether the classification so suggested fits in with the conclusions arrived at in adjoining districts; whether we can arrive at any connected history of the sequence of events connected with the caves consistent with all the information so gathered.

Such are the questions I invite the Society to discuss with reference to a part of North Wales, and I propose to bring forward the evidence I have collected on the subject in the following manner:—

A. *The Drifts of the Vale of Clwyd.*

1. The Arenig Drift.
2. The St. Asaph Drift.
3. The Surface-drift.

B. *The Caves of the Vale of Clwyd.*

1. The Caves.
2. The Cave-deposits.

PART II.

The Arenig Drift.

Any one standing on Arenig or Llyfnant and looking round over the wide expanse of unenclosed moorland, would see at a glance that there, to the west, was a basin in which, under somewhat different conditions, snow might collect to any depth and, compacted into ice, crush its way out towards Bala between the two Arenigs and over the col between Llyfnant and Arenig Mawr, towards the head of Bala lake. There, to the north, was an area on which névés would be formed of the snow that was blown from the crags of Snowdon or Moel Siabod, or many another glorious peak. There is the western sea stretching away beyond the mountains of Harlech, and feeding with moisture the prevalent south-west wind, which keeps the hill-sides for ever damp, and at Blaenau Ffestiniog, as I was informed by Mr. J. H. Williams, throws down yearly 133 inches of rain. The dark southern end of the valley west of Arenig still holds the winter's snow in its deep shadow far through the summer, and has in consequence the name of Twll-yr-eira, "the hole of the snow." The long esgair-like ridges running down from it are probably due to the torrents diverted by the snow.

Push the mountains up till the moisture that fell should all fall as snow, and the summer's sun should quite fail to undo the winter's frost, then the névé must form there, and glacier-ice must flow from the Arenigs and Siabod, from Snowdon and the Carneddau.

But we are not left to mere speculation on this point. Over the col and along the east slopes of Llyfnant the glacial striæ are still seen running south. They score the rock in long east and west furrows on the rounded shoulders of Arenig Mawr above Milltirgerig.

Here and there, in some deep hollow, the remains of the old drift is still seen, and a few scratched stones are found in the fine putty-like felspathic mud worn as the flour of rock in and under the ice from the volcanic ashes that there abound. An example of this drift is seen in the hollow scooped out in the soft Graptolite-bearing shale east of Maengrugog.

Also we see whence the boulders came that lie scattered over all the region to the east. Under every precipice of ash and various porphyritic rock there is a talus formed of enormous blocks fallen from the cliffs above. These are mostly well-marked rocks which do not occur again in place among the formations further east.

So we can trace this drift by its boulders and fine felspathic mud and small variety of rock up to the valleys of the Dee and Clwyd and far beyond.

As we travel east the fragments from the rocks of Arenig and its surrounding district become, of course, less conspicuous compared with the material that the ice has gathered on its way; but all the material has been transported from the west—all from the rocks of Wales—and the striations on the solid rock agree with this. We have already noticed how the grooves ran round the

shoulders of Arenig and pointed to the east. Down into the valley of the Dee between Corwen and Bala; up the steep slope of the Berwyns, as shown by the east and west striæ south of Nantcaweddau; hill after hill bears traces of the passage of the ice in that direction. There must have been some barrier on the north, perhaps the foot of a great ice-sheet from Scotland and the Lakes, so that the Welsh ice crushed its way eastward over hill and dale, ignoring all the highest ranges in its course, down into the Vale of Clwyd, scoring the limestone rocks at Cefn, as seen in the road-cutting behind the stable-yard; then up over the high hills forming the northern end of the Clwydian Range, as seen on the top of the hill S.E. of Cwm; across the Hope Mountain and Minera; all the striations running roughly east. No icebergs coming from the west can have grounded behind Cefn. All the evidence points to land-ice as the agent to which we must refer these striæ on the solid rock.

Along the Clwydian Range huge blocks of the volcanic rocks of Arenig are common. A group is seen by the cottages above the Grove near Bodfari. One enormous boulder lies at the junction of the highest mountain-fences N.W. of Moel Fammau.

The more northern portion of the drift, derived from the Snowdon rather than the Arenig area, might perhaps be distinguished. There seems to be a difference between the older drift near the north coast and that a little further south; but all comes from the west.

The western drift, I think, is seen in the deep sections which the Elwy has cut into the hill-sides above Dolben, and especially at the bend in the river near Dol, where landslips have, however, somewhat complicated the section, bringing down some newer drifts which lay upon it higher up the slope.

One section gave the following succession:—

Fig. 1.—Diagram-Section seen at bend of River Elwy, near Dol.

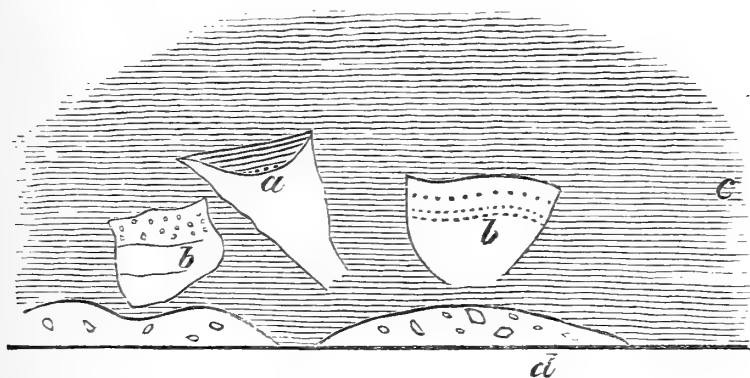

- a.* Black peaty clay. } Masses slipped from above.
b. Sand. }
c. Reddish boulder-clay, resting, with a very irregular line of junction, on *d.*
 (Northern or St. Asaph drift.)
d. Blue-grey boulder-clay. (Western Drift.)

The newer drifts rest with a very irregular line of junction on an

old blue-grey clay with boulders, all from the Welsh rocks to the west.

In the Vale of Clwyd the denudation which cut down through the soft or easily undermined strata of the St. Asaph (or Northern) Drift seems to have been often arrested when it reached the stiff tough older clay which we have called the Arenig (or Western) Drift.

At the bottom of the cliff beyond Brynelwy, near St. Asaph, where the river had removed the débris from the landslips, a dark blue clay, with boulders of Welsh rocks only, used sometimes to be exposed; and below the Mount, nearer St. Asaph, the section by the river often shows a similar dark blue boulder-clay overlain irregularly by the Marine Sandy Drift (see Section, fig. 3, p. 81). The top of this blue boulder-clay is remanié, as in the Colwyn Sections, only that in the Elwy the remanié surface of the old drift is a boulder-clay, while at Colwyn, in the section next to be described, it is a sandy clay.

Along the coast in Colwyn Bay a similar dark blue clay full of scratched stones, all of which are from Welsh rocks, is exposed here and there. For instance, at the base of the cliff about 200 yards N.W. of the Bath House at Aberrhyd, where the following section (fig. 2) may be seen:—

Fig. 2.—Section seen in Sea-cliff, about 200 yards N.W. of Bath House, Aberrhyd, Colwyn Bay. (Scale 80 feet to 1 inch).

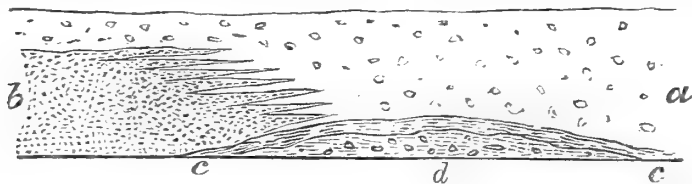

- a. Chocolate-red clay, with boulders; some scratches.
- b. Sand.
- c. Yellow laminated sandy clay.
- d. Blue clay, with many scratched stones.

d represents the older clay left by the ice from the great snowy region to the west, which crept downwards from the central gathering-ground, and probably at one time levelled up much of the low-ridged country on the borders of the mountain land. In this no trace of organism has ever been found, except, of course, the fossils in the fragments transported from the older rocks.

Changing somewhat locally according to the source from which it is derived, it still has much in common wherever it occurs; but its chief character is this, that in the district under examination it contains only material from Welsh mountains in the west.

This, then, is the oldest drift I know of in the Vale of Clwyd. Call it for local purposes the Arenig Drift, the Western Drift, the Snowdon Drift, the Great Ice Drift, the Older Drift.

I deprecate the use of the name "Boulder-clay" as a technical term for any subdivision of the series. As a descriptive term for any

clay with boulders in it, it is required for current language. So the word *drift* is required for common use in the sense of transported superficial deposits not being volcanic ejectamenta, or rock decomposed in place, or otherwise included by more strict definition.

What seems certain is that, starting in the Arenig district, we find an ancient boulder-clay which contains no fragments from any other district, and no trace of marine action, but follows the tracks of the land-ice away to the east. Whether we are right in referring to the same age and origin certain isolated patches of boulder-clay which occur at the base of all the marine drifts of the north-east of Wales and its borders, is another question; but it seems to me that there is a strong *à priori* reason for expecting that such patches should be left here and there, and much evidence that they have been detected in some cases. Besides the sections described above, in which there seems reason to suspect its existence, I may appeal to the publications of many other observers for the occurrence of an older, probably land-ice drift, underlying the marine drifts of the same or adjoining districts. See:—

EYTON. Geol. Mag. vol. v. p. 349.

HALL. Geol. Mag. vol. vii. p. 509.

MACKINTOSH. Geol. Mag. vol. ix. p. 15; Quart. Journ. Geol. Soc. vol. xxix. (1873) p. 355, footnote; vol. xxxiii. (1877) p. 738.

MELLARD READE. Quart. Journ. Geol. Soc. vol. xxx. p. 27; vol. xxxix. p. 83; vol. xli. p. 102.

DE RANCE. Proc. Geol. Assoc. vol. iv. p. 221.

STRAHAN. Mem. Geol. Survey, "Geology of the coasts adjoining Rhyl, Abergele, and Colwyn;" Quart. Journ. Geol. Soc. vol. xlii. (1886), pp. 36, 37.

This drift cannot be traced continuously to the east or north into the drifts of which the succession, local or general, has been made out. We follow it to the margin of the Cheshire plains; but where it ended is not so clear. It is everywhere covered by newer deposits over the low ground around the mountain-group from which it came. Mr. Mackintosh has traced what he considers to be the "junction of the Arenig felstone and Eskdale granite dispersions" along the hills north of Llangollen (Quart. Journ. Geol. Soc. vol. xxxv. 1879, p. 425; vol. xxxvii. 1881, p. 361); and Mr. Searles Wood, chiefly from the evidence collected by Mr. Mackintosh, believed that the Arenig ice terminated somewhere along that line (*ibid.* footnote). But whether left by the Arenig ice at an earlier stage of further eastward extension, or derived from its terminal boulder-clays during the period of submergence, there is no doubt that the Arenig rocks occur in the drifts far over central England.

It is difficult to correlate land-ice drift with marine. Moreover the oldest drifts of East Anglia show such a preponderance of northern material that we must suppose that, although we may find there drift of approximately the same age, it belongs to a different ice-stream. How the various parts of such a sheet turn round the hills, cross, overlap, and, in the greater strength of one or other mass,

predominate, may be seen in the beautifully clear view of the Greenland ice given in the Report of the Danish Commission (*Meddelelser om Grönland, Heft 1: Copenhagen, 1879*).

What is a well-established generalization from the examination of the drifts of Eastern England, and bears upon the question now before us, is that there are along the eastern coasts two quite distinct stages—an earlier stage, in which there is more evidence of the direct action of ice, though the deposits are marine like those of later date, and these older drifts contain an Arctic fauna; and a later stage, also marine, resembling the boulder-clay from which it is chiefly derived, but containing few northern forms of life and no evidence of glacial conditions prevailing near.

See also:—

SEARLES WOOD. *Quart. Journ. Geol. Soc.* vol. xxxvi. 1880, p. 516; vol. xxxviii. 1882, p. 707.

GEIKIE, J. 'The Great Ice Age,' 1877, pp. 366–381; 'Prehistoric Europe,' 1881, p. 264.

SEARLES WOOD. *Geol. Mag.* dec. 2, vol. v. p. 15.

A type of the older drift with Arctic shells, perhaps the marine equivalent of the Arenig drift, may, I think, be seen at Dimlington and Bridlington (see references below, pp. 91, 92).

Other examples might be quoted, for instance the Arctic shells found by Brown in the drift at Elie, in Fife, and Errol, in Perth, which, according to Otto Torell, were the same as those now living in front of the Great Glacier at Spitzbergen. (Brown, *Rev. Thos., Trans. R. Soc. Edinb.* vol. xxiv. p. 627.)

In such investigations we are continually met by the great difficulty of determining whether a drift is not re-made in some way or another, and whether scratched stones and shells may not have been derived from older deposits. (See also, Kinahan, *Geol. Mag.* dec. 2, vol. i. "Glacialoid or Re-arranged Drift;" Mellard Reade, *Proc. Liverpool Geol. Soc.* 1873–74, p. 50, "Tidal Action as a Geological Cause.")

Some have suggested that the shell-bearing drifts of North Wales represent portions of the sea-bottom thrust forward by the ice-foot and pushed up the flanks of the mountains till, on the melting of the ice, they settled down where they now lie. There seems to be no doubt that such transport of frozen masses uphill and the coming to the surface of matter in glacier-ice does occur. It is analogous to the travelling of boulders across valleys and uphill in glacier-ice, as suggested years ago by Mr. Goodchild in explanation of some of the phenomena of the Lake-district (*Geol. Mag.* dec. 2, vol. ii. 1874; *Quart. Journ. Geol. Soc.* vol. xxxi. 1875, p. 55), and more generally by Prof. James Geikie (*Trans. Geol. Soc. Glasgow*, vol. iv. 1874, p. 235, in the 'Scottish Naturalist,' and in his paper "On the Inter-crossing of Erratics"). Professor Carvill Lewis refers the shell-bearing deposits of North Wales to the terminal moraine of a mass of land-ice, which carried granite from Scotland and shells and flint from the bed of the Irish Sea (*Brit. Assoc.* 1886; *Geol. Mag.* dec. 3, vol. iv. 1887, p. 29). I think, perhaps, he would make an exception

in the case of the lower-level sands such as those of the Vale of Clwyd; but this distinction would be difficult to maintain, and the manner of occurrence of the North-Wales Marine drift along well-defined terraces and with current-bedding and horizontal stratification bearing a definite relation to the physical geography of each district renders this explanation improbable in that case. Besides, the character of the shells is not consistent with the idea of such extreme glacial conditions. The Moel Tryfan deposit, as pointed out by Gwyn Jeffreys (Quart. Journ. Geol. Soc. vol. xxxvi. 1880, p. 355), is not strictly glacial; the fauna has a Norwegian rather than an Arctic facies.

So, again, in the case of the marine drifts of the plains of Cheshire and Lancashire, Shone draws attention to the mixture of forms (Quart. Journ. Geol. Soc. vol. xxxiv. 1878), and suggests in explanation that the Scandinavian shells in the sands and gravels were derived from an older Boulder-clay (p. 389). Even in the case of the clay-drift, which he thinks was dropped in quiet deep water, he shows that many of the shells must have been carried into it from a sandy shore, and explains this (p. 388) by reference to existing conditions in the estuary of the Dee, where shells with sand in them now get carried out by thin shore-ice into deeper water. In this case it is clear that scratched boulders of granite &c. from the northern land-ice drift must get dropped into the same clayey deposit without having their striæ obliterated by being rolled along a shingly shore.

Bearing all this in mind, we may now pass on to consider the second division of the drifts of the Vale of Clwyd, a stage in which the deposits were derived in part from the old western drifts above described, and also in part from the boulder-clays which were formed at the end of the ice from the Lake-district, and from the shingle which travelled along the shore from the flint-bearing drifts of other areas.

PART III.

The St. Asaph Drift.

In a paper read before the Chester Society of Natural Science in 1880* I spoke of this as the Clwydian Drift; but as further subdivisions seem to be already possible, I now use the name St. Asaph Drift as more precise for the stratified beds on which the Cathedral of St. Asaph stands. It might be called the *Sea-drift*, being the only drift in the vale which we know to have been of marine origin; or we might speak of it as the *Newer Drift*, to distinguish it from that older deposit on which it rests irregularly wherever the two are found together, and which, on other evidence, seems to belong to a previous state of things. It might be referred to as the *Northern Drift*, seeing that in it we find for the first time in the history of the vale fragments of northern origin.

* Proc. Chester Soc. Nat. Sci. no. 3 (1884)

This drift belongs to a period of submergence of which there is other evidence all round the coast of Wales. Hence it is clear that we must divide it into two stages, the deposits of the submergence and those of the emergence. There must have been the waste along the shore of the encroaching sea as the land subsided, and the further down the valleys sunk the safer from further denudation was the débris swept into the deeper parts. There must have been shingly shores and cliffs of boulder-clay of the Arenig Drift, along which landslips took place, and the clay, not always broken up, and the included stones, not always rolled, settled down into the fjords. Round the shore there would be a shingly beach.

Then there was the period of emergence, when the land rose to where we have it now. This was, of course, a time of greater waste and destruction, when the soft, newly-formed beds were lifted up to the level of the wind-waves, or, if they survived the lash of the waves, were raised out of the sea to be acted upon by the summer sun and winter's frost—by the torrents of rain and the mountain-streams.

So we must expect to find along the margin of the valley more sand and gravel, and towards the centre more clay.

Now, to examine the sections in the drifts of these stages, I will take them in an order convenient for my purpose of correlation, first giving the most typical and clearly made out, and then following them, as suggested by the particular points of variation which I am endeavouring to explain.

The river Elwy, when it has once turned north after breaking out of the gorge under the Cefn rocks, generally clings rather to the eastern side of the valley till it joins the Clwyd at Rhydyddaudwr, above Rhuddlan.

Down as far as Pontyralltgoch it cuts into stained Carboniferous rocks capped by drift; but soon the solid rock drops out of sight, and the river washes the base of a slippery slope of clay and sand, as seen where it cuts into the steep bank south of Brynelwy.

The greater part of the drift seen in this section must be referred to the St. Asaph Drift. The dark-blue boulder-clay sometimes exposed at the base near the north end may be, as we have said above (p. 76), the old *Arenig Drift*. A mass of gravel and sand at the top, which may be the gravel of the shore during emergence, is brought against the red clay by an ancient settlement, the exact amount and direction of which is obscured by subsequent slippings of the face of the cliff; but they both belong to the same set of deposits, and contain the same remains.

In the wood, less than 100 yards to the south, more clay is seen, but the lower part of the section there is obscured by talus and overgrown.

The upper sand and gravel is generally grey; the clay is red. Lower down the valley, about $\frac{1}{4}$ mile south of the Palace of St. Asaph, a similar dark-red clay with boulders rests upon sharp red sand, as if derived largely from New Red Sandstone. North of the city, just below the Mount, another section through the St. Asaph drift is

generally well exposed, being kept clear of talus by the river, which sweeps the foot of the cliff. (See section, fig. 3.)

Here bands of reddish clay occur within the mass, and a red boulder-clay comes on above on the east and south.

It is excavated for brickmaking near the railway, a little north of the station of St. Asaph, and again close to the line where the railway crosses the road to Llanerch farm-buildings. This clay seems to thicken to the south. In the well at Llanerch it was proved to 37 feet 6 inches; while at Maeselwy, in the well, it was found to be 54 feet 10 inches in thickness. The boulders were chiefly at the base.

Fig. 3.—Section seen in East Bank of the Elwy below the Mount, St. Asaph. (Scale 80 feet to 1 inch.)



a. Surface wash.

b. Alternations of sand, with brown or red clay and loam; varies much from year to year, as the river cuts back the cliff. The middle part is, in general, distinctly banded with even-bedded sand and loam; contains flint, granite, and sea-shells; scratched stones not common.

c. Blue clay, with many scratched stones; all from Welsh hills (except some stones from b, which have got into the top puddled and re-sorted part).

On the eastern side of the tongue of drift that parts the Clwyd and the Elwy at St. Asaph, opposite Bronwylfa, on the south, there is a pit showing a similar section in the St. Asaph Drift. Here it is chiefly sand, for which the pit was dug. I have found a few fragmentary sea-shells in it.

On the west side also of the valley a similar drift is seen. In the road-cutting opposite Y Roe there is a red clay with shells and boulders. Up the road towards Wigfair Uchaf red sand and clay is excavated here and there. East of Ffynonfair Chapel, just below the bend of the road where it leaves the cliff, and about $\frac{1}{4}$ mile south of Glanllyn, there is a section, the upper part, at least, of which must be referred to the St. Asaph Drift.

On top in the road-cutting there is a kind of rain-wash brick-earth	ft.	in.
full of nests of wild bees.....	8	0
Below this is a reddish boulder-clay	25	0
which rests on a red sand	25	0
and that on greyish boulder-clay, some stained red	? 35	0

It is about 50 feet from this to the bottom of the valley, but the whole section, though changing from year to year, is generally much obscured by slips and talus, especially towards the base, so that I could not make out whether there was rock at the bottom of the section here. It does occur at this level on the other side of the valley.

These sections show that we have a variable deposit of gravel and sand and boulder-clay; and we must now examine in greater detail the constituents and general characters of the beds before we carry our identification further. There seems to be occasionally a surface-gravel, coarse and grey, the result of the winnowing of the St. Asaph Drift during the emergence; but the highest beds, especially along the central part of the valley, generally consist of red boulder-clay, the middle of sands and gravel, with subordinate clay and loam, the bottom of re-sorted boulder-clay or sand resting on the old blue boulder-clay, some of which, at any rate, seems to belong to the more ancient western land-ice drift.

Again we notice two distinct groups of included fragments—one consisting entirely of those with which we have become familiar in the Arenig or ice-drift. These are stones from the far-off mountains of Wales, and others which the ice carried from much nearer to where they now lie. Where they have been dropped into clay the scratched stones retain their striæ; where they occur in gravel the scratched stones are rare, and only “the ghosts of scratches” can be seen.

But there is another group of rocks, *none of which are scratched*. Among these there are many which do not occur in place in Wales at all. They are in form and surface like the stones found on any beach.

The characteristic rocks are Scotch and Lake-district granite and other igneous rocks and flints. This is true chalk-flint, not chert from Carboniferous rocks, of which there is also some, though rare; for the principal chert-bearing strata had by this time been removed from the country west of the Vale of Clwyd. These all occur both in the gravels and the upper clays.

In the south part of the section, near Brynelwy, I have found an angular fragment of one of the scratched boulders buried in the clay. This boulder had probably been exposed in some preexisting cliff of boulder-clay, had been shattered by frost or sun or fall, and one bit had dropped unrolled into the depth below, where it was buried in the mud and preserved from further injury. Thus it retained the sharp fractured edges, and also one face, which had formed part of the surface of the ice-scratched block. This, I take it, was a stone out of a cliff of the old Arenig ice-drift, which was washed by the sea in the submergence during which the St. Asaph Drift was formed.

I have found also in the sand and gravel of the same section clay-balls, containing inside only fragments of Welsh rocks, but with pebbles of the gravel stuck all over the outside, just as I have seen balls of alluvial clay or older boulder-clays rolled on the shore near Prestatyn, or Pensarn, or Colwyn, or near Penrhos in Anglesey,

all similarly studded over with pebbles, which have stuck to the moistened, softened outside of the clay-balls as they rolled along.

At the time of the formation of the St. Asaph Drift the nearest cliffs of boulder-clay were the masses of western land-ice drift, in which the material was all from the west. All the scratched stones were out of that, and therefore from the west. There were other cliffs of boulder-clay to the north and east, from which northern boulders fell into the sea and drifted along the shore; but the pebbles from them had a long journey by all sorts of conveyances before they reached the Vale of Clwyd and their glacial polish and grooving was all worn away.

Of course, the distinction founded upon the occurrence of north-country granites and flint is only local. The north-country land-ice drift contains the granites and other rocks of that country striated, and the older boulder-clays of the east of England are full of flints and other chalk *débris*. But in the Vale of Clwyd these occur in the newer marine drifts only.

We are not, however, dependent on such evidence alone to prove that these deposits are the result of the action of the sea. Shells are not uncommon. They are generally fragmentary, it is true, just like the shells thrown up in the sand and gravel of the North Welsh coast to-day; but they are, many of them at least, determinable, and I have made a small collection in the river-banks described above, close to St. Asaph.

They were originally determined for me by the late Searles Wood, and have been since seen by many good authorities. The list I have given in column I. in the table, p. 93.

So the evidence goes to show that here we have a marine deposit much like that which is being formed in many places on the North Welsh coast at the present time, where banks of drift and clay of various age are being wasted by the waves. There seems to be no necessity for supposing that glacial conditions still prevailed. The forms of life are not Arctic. None of the stones peculiar to the deposit are glaciated; only those derived from the Welsh hills are striated, and they were probably washed out of the old Arenig ice-drift.

If it is asked, how, then, did the boulders from the north get transported to the Vale of Clwyd? I would reply that many may have travelled south on ice when the northern ice abutted against the ice-bound shore of North Wales, but they were not then carried into the Vale of Clwyd. They came there and along the coast with the shore-shingle, as did the flints, which cannot have come from the same country as the granites. We may expect to find, somewhere further north, patches of the old north-country boulder-clay with the granite blocks in it scored by ice. But when they and the flints were travelling along the shore as shingle all the original striæ were removed.

In following the Arenig Drift to the margin of the Cheshire plains we are, of course, tracing it to what may have been always, and must have been for a long time, its extreme limit. Therefore it is not strange to find that there is a larger proportion of northern forms among the shells found in the drifts of Cheshire and Lancashire.

Mr. Shone, in his excellent paper (Quart. Journ. Geol. Soc. vol. xxxiv. 1878, p. 384) "On the Glacial Deposits of West Cheshire, together with lists of the Fauna found in the Drift of Cheshire and adjoining Counties," discusses the difficulty of explaining the mixture of northern and southern forms in the drift. He says (p. 389) that it is "more than probable that the Scandinavian shells of the Middle Sands and Gravels have been derived from the Lower Boulder-clay;" and again, after pointing out that the Upper Boulder-clay rests upon an irregular surface of the Middle Sands and Gravels, he says, "what, therefore, more likely than that the southern forms, which are very rare in the Upper Boulder-clay, should have been derived from the Middle Sands?" I would only go a little further in the same direction, and ask whether the Upper Boulder-clay may not have been derived, together with its Scandinavian shells, from an earlier Boulder-clay, to which they properly belonged.

It is shown by Dr. Ricketts that flints occur in the Boulder-clay near Birkenhead (Quart. Journ. Geol. Soc. vol. xli. 1885, p. 597). Mr. Mackintosh, in his paper "On the Limits of Dispersion of the Erratics of the West of England and East of Wales"*, notices the occurrence of flint in the marine deposits of sand and gravel along the eastern borders of Wales; and other writers, many of whom are referred to in the course of this paper, notice the occurrence of flint on Moel Tryfan and in the drift of Lancashire and Cheshire.

Aitken records that flint has been found on Holcombe Hill, near Manchester, at an elevation of nearly 1000 feet above the sea (Trans. Geol. Soc. Manchester, vol. vii.).

If shore-ice is needed to explain a few exceptional groups of boulders in the drift or on the hills, that does not involve glacial conditions. I have seen shore-ice in the estuary of the Dee that would float any boulder in the Vale of Clwyd. I have seen at Connahs Quay vessels frozen up in pack-ice 12 feet thick, which broke away in icebergs 50 yards across; and Mr. Alfred Walker has seen the boulders shifted by shore-ice along the same coast.

The St. Asaph Drift falls to lower levels as we trace it down the vale to the north. This is probably due chiefly to the original northerly slope of the valley in which it was thrown down, but also may have been increased by an unequal movement of elevation, and probably more by the greater denudation near the mouth of the estuary.

It occurs in bosses and ridges of red sandy drift near Rhuddlan, the last place where I have seen anything that could be referred to it being a sand and gravel, with bits of red shale and clay, in a ditch-section $\frac{1}{2}$ mile N.W. of the village, and the upper beds passed through in the Aberkinsky borings. It was probably represented in the Foryd boring also †.

* Quart. Journ. Geol. Soc. vol. xxxv. 1879, p. 446; Trimmer, Proc. Geol. Soc. vol. i. 1831, p. 331; Journ. Geol. Soc. Dublin, vol. i. 1838; Mackintosh, Quart. Journ. Geol. Soc. vol. xxxiii. 1877, p. 736; Buckland, Proc. Geol. Soc. vol. iii. 1841, p. 584; 'Athenæum,' 1842; Darwin, Lond., Edinb., & Dubl. Phil. Mag. vol. xxi. 1842.

† "Notes on the Geology of the Vale of Clwyd," Proc. Chester Soc. Nat. Sci. 1884, p. 36

It is of great importance for our present purpose to inquire what is the character of this drift where it abuts against the rock along the flanks of the hills that bound the vale. The clearest section is that seen in the large limestone-quarry by the road north-west of the old British camp of Parcymeirch, near the village of St. George; here a well-washed sand and gravel abuts against a steep slope of weathered limestone, as shown in the section, fig. 4.

Fig. 4.—Section in Quarry near the Village of St. George.
(Scale 30 feet to 1 inch.)

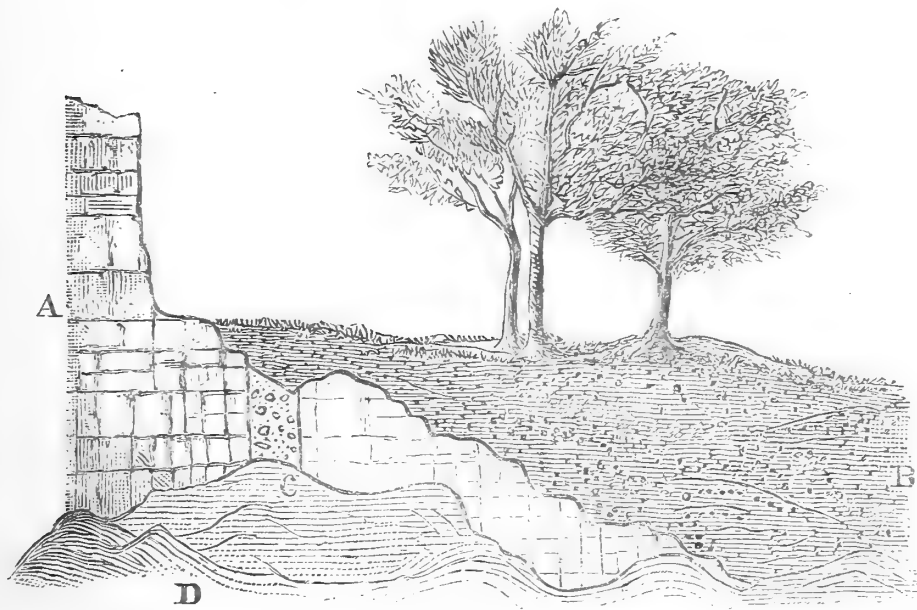

- A. Mountain Limestone, dip 20° N.N.E.
 B. Sand and gravel.
 C. Reddish boulder-clay, with fragments of sea-shells and scratched stones.
 D. Talus.

In this section it is quite clear that a boulder-clay has filled up an embayed corner in the limestone, and that a sand and gravel swept down the ravine, perhaps into the sea, has caught against the projecting mass, covering the crags and the clay-filled hollows. The process of quarrying has left a thin wall of limestone in front of the gravel and underlying clay-drift, the removal of which in one place gives the appearance of a drift-filled fissure. The red colour of parts of this clay may have been derived from the decomposition of the limestone in which it occurred, and not from the New Red.

Further west still, at Colwyn Bay, variable deposits of sand, gravel, and clay occur at various levels up the flanks of the hills. From some of these, at a height of about 120–150 feet above the sea, Mr. Alfred Walker has collected the shells given in column II. of the Table, p. 93.

All, except *Astarte borealis*, are now found upon our coasts (see Jeffreys's Brit. Conch. vol. ii. p. 320).

On the other or eastern side of the Vale of Clwyd, the Talargoch beds abut against the rock at the northern end. Here mining operations have been carried on along the rock-surface, seeking for the lumps of ore that occur in the base of the gravels like the "stream tin" in Cornwall. I have found shells, *Tellina balthica*, in some more clayey beds along the edge of the rock, and, in the deep gravel at the bottom of the workings, bones &c. are said to have been found (Proc. Chester Soc. Nat. Sci. 1884, p. 31) in old times, and in more recent times similar discoveries have been reported.

If we are ever able to distinguish between the deposits of the submergence and those of the emergence, the Talargoch gravels will, I suspect, be referred to a late time in the age when the land was coming up again.

Now we must bear in mind, First, that the colouring-matter of the New Red Sandstone occurs as a thin pellicle of oxide round the grains, so that when they have been much knocked about, the sand is colourless, and the oxide is carried in the water to stain new beds of finer texture where it can settle down.

Secondly, that the New Red does not attain any considerable elevation in the Vale, so that in the submergence it was soon below the reach of ordinary denudation. Thus we may expect that many of the drifts derived from it will not be red, because the colour has been washed out, and many drifts of the same, or only slightly different age, will be the one red, the other grey, according as any source of the red colour was still in the line of drifting or not.

Great masses of grey gravel, near Brynypin, at an elevation of about 500 feet, clearly belong to some part of this age; and when the sea was there it must have left gravel and sand above the more ancient drifts along the Elwy above Pontyrddol.

At Brynypin there must have been a tidal swill. All down the east slope of the same hill, on the south side of Bodelwyddan Park, the red-clay drift is seen in the road-cuttings, where boulders of north-country granite are not uncommon, at any rate up to a height of 300 feet.

On the eastern flanks of the Clwydian range there are grey gravels high up the hill on the south side of Cwm Nannerch, for instance, which might well belong to this same age; but in the absence of fossils and opportunities for a more careful examination of the constituents, we must suspend our judgment here; for they might be also the gravels at the foot of the great ice, when it had receded just so far. The esgair drift below also, near Bryn Nannerch, requires more evidence before we can feel sure about its age.

Three miles and a half to the E.S.E. from here, on the hill-top near where the "g" of Caerhug is engraved on the 1-inch map, $3\frac{1}{4}$ miles W.S.W. of Northop, some 650 feet above the sea, I have collected sea-shells in the drift. This is an interesting place to find them, for it lies halfway between the shell-bearing beds of Moe Tryfan and the similar deposits near Macclesfield; while if we trave

on in the same line, as far again, we find the Hessle beds containing the same fauna.

In all these beds there are flints somewhat rolled, subangular, as they call them, but never worn to pebbles.

Round the south coast to Pembrokeshire we find the same, and the low-lying plateau at St. David's is covered by a gravel containing flints; but I have not as yet found traces of shells in it there.

This is part of a wide submergence, and of course, when the higher hills were submerged to the extent that I have shown above, the lower regions and the hollow places were all below the sea, the lowest going down first; so, as the climate was growing milder at the close of the age of glaciers, the more southern and temperate forms of life kept following on the receding ice, but the earlier deposits would still contain many of the Arctic types. This may be the reason why, in Mr. Shone's lists of shells from the drifts in Cheshire and South Lancashire, there are so many more northern species than appear among the shells in the Vale of Clwyd, or Colwyn Bay, or the higher levels of Moel Tryfan, Caerhug, or Macclesfield. Or it may be that the Scandinavian shells are derived from an older boulder-clay.

But we must not attach too great importance to this point; for the persistence of a few northern forms does not justify our referring even these beds to the glacial age. Nearer the mountains we have abundant evidence that the deposits we have called the St. Asaph Drift are Postglacial. The striated stones are all such as might be derived from the preexisting Arenig Drift; none of the stones peculiar to the St. Asaph Drift are glaciated. Broken glaciated boulders, balls of Arenig boulder-clay, and, with very few exceptions, shells not of Arctic type occur in this St. Asaph Drift.

Deposits of a submergence which succeeded the age of great glaciation have been recognized round the north and east of Wales (Mackintosh, *Quart. Journ. Geol. Soc.* vol. xxxviii. 1882, p. 184). Along the "Severn Straits" and beyond into the Midland counties, relics of the material washed from the older drift are recognized* (Rev. W. Lister, *Q. J. G. S.* vol. xviii. 1862; Davies, *Proc. Geol. Assoc.* vol. iv. 1876, p. 423; Crosskey, *Proc. Birmingham Phil. Soc.* vol. iii. 1882, p. 209).

Marine deposits of this age occur over the plains of Cheshire and Lancashire, as may be seen from the references I give below with the lists of shells (see also:—De Rance, *Quart. Journ. Geol. Soc.* vol. xxvi. 1871, p. 641, *Mem. Geol. Survey*, "Superficial Geology of S.W. Lancashire"; Mackintosh, *Chester Soc. Nat. Sci.* Feb. 1876, *Quart. Journ. Geol. Soc.* vol. xxv. 1869, p. 407, vol. xxxiii. 1877, p. 732; Ricketts, *Proc. Liverpool Geol. Soc.* 1876-7, p. 245; Morton and Shrubsole, *Proc. Liverpool Geol. Soc.* 1875-6; Morton, *G. H.* ib. 1876-7, p. 294, &c., *Rep. Brit. Assoc.* 1876, p. 110, *Geol.*

* In a paper just published, Mr. Deeley says of the Pleistocene succession in the Trent Basin, "all the deposits I have described as belonging to the two previous epochs [Older and Middle Pleistocene] were formed during one continuous period of submergence" (*Q. J. G. S.* vol. xlii. 1886, p. 467).

Mag. dec. 2, vol. iii. 1876, p. 526; Strahan, Mem. Geol. Survey, "Geology of Chester"; Mellard Reade, Quart. Journ. Geol. Soc. vol. xxxix. 1883, p. 92; Wood, S. V., Geol. Mag. dec. 2, vol. iii. 1876, p. 396, footnote).

But along the east coast, both north and south of the Wash, marine conditions prevailed long before the ice had receded into the high mountains, and in the shells of the older drift we find the record of this.

I have not entered into the discussion of the exact subdivisions or correlation of these beds. I have referred to some authorities for just the point above stated of an older Glacial and a newer Post-glacial drift. For local purposes a more minute subdivision is possible and useful, but at present I think we must, for wider correlation, adhere to a simpler system, and speak of one great glaciation succeeded by one great submergence in the west; and in the east, an older marine, probably synchronous with the first or land-ice, and a newer marine, the chronological equivalent of the second or age of submergence in the west. For some suggestive remarks on this subject see Jamieson, "On the Cause of the Depression and Re-elevation of the Land during the Glacial Period," Geol. Mag. dec. 2, vol. ix. 1882. (See also Dakyns, "Glacial Deposits north of Bridlington," Yorksh. Geol. Polytech. Soc. vol. vii.)

In the subjoined table (p. 93) I have given a list of the shells in the St. Asaph Drift and from beds in adjoining districts, which it appears to me belong to about the same age. I have added in the last column for comparison a list of the shells from what is probably a marine deposit of the age of the Arenig land-ice.

By reference to the authors quoted it will be seen that in many cases there are subdivisions of importance in the beds which I have included under one head, and that some of the forms which I have recorded may have been derived from older deposits. It is clear also, from the great difference of elevation, lithological character, and proximity to the mountains, that a somewhat different facies may be expected from deposits which have been laid down at different times in one long age of changing geographical conditions and climate. But nevertheless this point seems to be clearly established, that the shells enumerated in columns I. to VII. all belong to a somewhat northern temperate group (*i. e.* are Post-Glacial), that under the deposits in which they occur on the west are the land-ice drifts of the Welsh and Lake-country mountains, and that below their equivalents in the east are Old Boulder-clays containing, either scattered through the mass or in included masses of contemporaneous sand and clay, a severely Arctic group of shells. These shells are recorded in column VIII.

I have omitted all notice of the Echinoidea or Foraminifera, as not being of sufficiently common occurrence to be useful for our present purpose of correlation.

The references to the formation, locality, and age, and the sources of information are as follows:—

In column I. are indicated the shells found in the marine sands

and gravels of St. Asaph. These were originally determined for me by Searles Wood. The collection is now in the Woodwardian Museum at Cambridge. See also:—

HUGHES. "On the Evidence of the Later Movements of Elevation and Depression in the British Isles," *Vict. Inst. or Phil. Soc. Great Brit.*, March 15, 1880, p. 6.

HUGHES. "Notes on the Geology of the Vale of Clwyd," *Proc. Chester Soc. Nat. Sci.* pt. 3, 1884, p. 29.

In column II. I have given an unpublished list, kindly placed at my disposal by Mr. A. O. Walker, of shells collected and determined by him from beds about 120–150 feet above the level of the sea in Colwyn Bay. These specimens are in the Grosvenor Museum, Chester.

In column III. I have recorded the shells from Moel Tryfan noticed by:—

TRIMMER. *Proc. Geol. Soc.* vol. i. 1831, p. 332; *Journ. Geol. Soc. Dublin*, vol. i. 1838, pp. 286, 335; *Rept. Brit. Assoc.* 1838, *Trans. Sect.* p. 86.

FORBES. *Mem. Geol. Survey*, vol. i. 1846, p. 336.

DARBISHIRE. *Geol. Mag.* vol. ii. 1865, Table, p. 298.

MELLARD READE. *Quart. Journ. Geol. Soc.* vol. xxx. 1874, p. 30.

RAMSAY and ETHERIDGE. 'Physical Geography and Geology of Great Britain,' 1876.

LYELL. 'Antiquity of Man,' 3rd edition, p. 525.

SHONE. *Quart. Journ. Geol. Soc.* vol. xxxiv. p. 383.

GWYN JEFFREYS. *Quart. Journ. Geol. Soc.* vol. xxxvi. 1880, p. 351.

Gwyn Jeffreys says that the Moel Tryfan deposit was not strictly a glacial one. The fauna has a Norwegian rather than an Arctic facies.

In column IV. I have placed the few shells which have been recorded from the sands and gravels which occur at intervals along the high ground that rises from the Cheshire plain on the west, from the Vale of Llangollen to the estuary of the Dee, thus forming the eastern boundary of the Vale of Clwyd. I have verified the occurrence of these by finding some myself, but I have not added to the species recorded by Mr. Mackintosh*.

In column V. I have placed together all the recorded shells from the drifts of the lower levels of Lancashire and Cheshire. For the subdivisions of these beds the paper by Mr. Shone (*Quart. Journ. Geol. Soc.* vol. xxxiv. 1878, p. 383) may be referred to. Mr. Shone thinks that the lower beds of his sections are of considerably greater antiquity, and indicate much more boreal conditions than the overlying sands and gravels and their covering clay. He suggests that some of the northern shells found in the upper deposits may have been washed out of older beds, and therefore not be a fair index of the climatal conditions of the deposit in which they are found. Mellard Reade considers that the various beds from which he has obtained shells in Lancashire and Cheshire are only local developments of one series. Provisionally he groups them all together under the title of

* *Quart. Journ. Geol. Soc.* vol. xxx. (1874), p. 712, vol. xxxvii. (1881), p. 360.

Low-level Boulder-clays and Sands (Quart. Journ. Geol. Soc. vol. xxx. 1874, p. 36).

It does not appear that any one has detected in that area any patches of the drift directly due to the northern land-ice from which so much of the material of all later drifts has been derived. The numerous records of glacial striæ on the solid rock lead one to think that there cannot have been much erosion since the ice, whether land-ice or iceberg, passed over it (see Mellard Reade, Proc. Liverpool Geol. Soc. 1872-73, p. 42; Morton, *ib.* 1876-77, p. 284). But as none of the marine deposits referred to under this head can have been laid down until after the recession of the northern ice, they must belong to an age of less severe climatal conditions. On the other hand, as the ice must have lingered on the high ground of North Lancashire and Wales long after the sea had covered the Cheshire and Lancashire plains, some of these Lancashire and Cheshire drifts may well be nearer the glacial age than the drifts the shells of which are recorded in columns I., II., III., and IV.

See also:—

EGERTON. Proc. Geol. Soc. vol. ii. 1836, pp. 189, 415.

BINNEY. Mem. Lit. Phil. Soc. Manchester, vols. viii., x. (1852).

MORTON. Proc. Geol. Soc. Liverpool, 1870-71, p. 91.

PATERSON. Proc. Warrington Lit. Phil. Soc.

MACKINTOSH. Quart. Journ. Geol. Soc. vol. xxviii. 1872, p. 388, with Note by Gwyn Jeffreys, p. 391, and note by Searles Wood, p. 392.

MELLARD READE. Quart. Journ. Geol. Soc. vol. xxx. 1874, pp. 27, 281, vol. xxxix. 1883, p. 83; Proc. Geol. Soc. Liverpool, 1874-75, p. 35.

FFARINGTON, quoted by DARBISHIRE. Quart. Journ. Geol. Soc. vol. xxx. 1874, p. 38.

In column VI. will be found a list of the Macclesfield drift-shells. I have not distinguished the older and newer beds of Mr. Darbishire. (Manchester Lit. Phil. Soc. vol. iii. 1865, p. 56; Geol. Mag. vol. ii. 1865, pp. 41, 298.) The shells recorded as having been found by Prestwich in 1862 were from the same drift in an adjoining pit.

See also:—

SAINTER. 'Rambles round Macclesfield.'

MACKINTOSH. Quart. Journ. Geol. Soc. vol. xxxvii. p. 363.

PLANT. Geol. Soc. Manchester, Feb. 1865; Geol. Mag. vol. ii. 1865, p. 179.

MELLARD READE. Mem. Lit. Phil. Soc. Manchester, 1864-65.

In column VII. I have marked the shells of the Hessle Beds, that is, practically, the shells collected by Professor Prestwich in the gravels of Kelsea Hill. The list was revised by Gwyn Jeffreys, and published in Prestwich's paper on the Kelsea Hill Beds (Quart. Journ. Geol. Soc. vol. xvii. 1861, p. 448). See also Clement Reid, Mem. Geol. Survey, "Geology of Holderness" (see below, p. 93).

These beds, according to Searles Wood, are postglacial, and are identified with beds which rest on Boulder-clay, and with others which are overlain by still more recent Lacustrine deposits with *Anodonta*, *Cyclas*, *Paludina*, &c.

It is interesting to note the occurrence of *Cyrena (Corbicula) fluminalis* in these beds, which (though, as pointed out to me by Mr. Clement Reid, it ranges down to the Cromer Forest-bed) is such a common and characteristic fossil in the March Beds and the post-glacial river-terraces of the south-east of England—the valley of the Cam, for instance (*cf.* Searles Wood, *Geol. Mag.* vol. ix. 1872). See also:—

PHILLIPS, *Quart. Journ. Geol. Soc.* vol. xxiv. 1868, p. 250.

WOOD and ROME. *Quart. Journ. Geol. Soc.* vol. xxiv. 1868, p. 146.

HALL. *Liverpool Geol. Soc.* Dec. 11, 1866.

SEARLES WOOD. *Geol. Mag.* vol. viii. Sept. 1871, p. 406.

LAMPLUGH. *Yorkshire Geol. Polytech. Soc.* 1879, pp. 8, 9.

JUKES-BROWNE. *Quart. Journ. Geol. Soc.* vol. xxxv. 1879, p. 397.

All the beds from which the fossils were obtained which are recorded in columns I. to VII. must be considered to belong to an age when severely arctic conditions had ceased to prevail, and which therefore may be called Postglacial.

In column VIII. I have indicated the shells which have been obtained from the Bridlington Drift. When examining the Dimlington Section some years ago, in company with Mr. Leonard Lyell, I noticed in the lower part of the cliffs a short lenticular mass of greenish sand full of shells. It was so small that we worked it out completely. In it we found *Nucula Cobboldia* perfect and *Astarte compressa* with valves adherent, and seven other species (see Hughes, "On the Evidence of the later Movements of Elevation and Depression in the British Isles," *Vict. Inst. or Phil. Soc. Great Britain*, March 15, 1880, p. 8). Mr. Lamplugh has since procured shells from similar beds in the same neighbourhood, and has well worked out the equivalent Bridlington Drifts (*Brit. Assoc.* 1881; *Geol. Mag.* dec. 2, vol. v. p. 509, vol. vi. p. 393, vol. viii. 1881, p. 535, vol. ix. p. 383; *Quart. Journ. Geol. Soc.* vol. xl. 1884, p. 312, in which are notes by Gwyn Jeffreys, E. T. Newton, and Dr. Crosskey; *Proc. Geol. Polytech. Soc. Yorkshire*, pt. i. 1881, p. 383, pt. ii. 1882, p. 27, pt. iii. p. 240, 1883).

See also:—

BEAN, WM. "A short account of an interesting deposit of Fossil Shells at Bridlington Quay," *Loudon's Mag. Nat. Hist.* vol. viii. 1835, p. 355.

YOUNG and BIRD. *Geol. Survey Yorksh. Coast*, 1822, p. 22.

SEDGWICK. *Ann. Phil.* 1826, ser. 2, vol. ix. p. 339.

PHILLIPS. *Brit. Assoc.* 1835, *Trans. Sect.* p. 62; *Geology of Yorkshire*, 1835, p. 40 (in the 3rd edit. p. 274, there is a note by Gwyn Jeffreys).

LYELL. *Ann. & Mag. Nat. Hist.* vol. xii. 1839, p. 324; 'Antiquity of Man,' 1873, p. 266.

FORBES. *Mem. Geol. Surv.* vol. i. 1846, p. 392.

SEARLES WOOD. *Crag Mollusca*, 1847-55. The Bridlington drift was then believed to be about the horizon of the

Mammaliferous Crag. Quart. Journ. Geol. Soc. vol. xxvi. p. 92, vol. xxxvi. p. 515, vol. xxxviii. p. 681; Geol. Mag. dec. 2, vol. i. p. 246, vol. v. p. 13.

SORBY. Proc. Geol. Polytech. Soc. West Riding, Yorkshire, vol. iii. 1858, p. 559, with the Foraminifera named by Rupert Jones.

GUNN. Essay on Geol. Norfolk, White's Gazetteer, 1863.

TYNDALL, E. Geol. Mag. vol. i. p. 142; Proc. Geol. Soc. Yorksh. vol. v. 1870, p. 7.

WOODWARD, S. P. Geol. Mag. vol. i. 1864, pp. 49, 142, 216.

CROSSKEY. Proc. Birm. Phil. Soc. vol. ii. p. 373.

SIMPSON. Geol. Nat. Hist. Repertory, vol. i. p. 57.

BEDWELL. Geol. Mag. dec. 2, vol. v. p. 517.

LECKENBY. Brit. Assoc. 1864.

GWYN JEFFREYS. Brit. Assoc. 1874, p. 83.

DAKYNs. Geol. Mag. dec. 2, vol. vi. p. 238, vol. x. p. 93; Proc. Geol. Soc. Yorksh. n. s. vol. vii. p. 123.

And the collections by Bean and others in the British Museum, and the Leckenby collection in the Woodwardian Museum at Cambridge.

In a note at the end of the list drawn up by Gwyn Jeffreys, and published in Phillips's 'Geology of Yorkshire,' 3rd ed. p. 277, he says, "All the above species are now living and inhabit the Arctic and northern seas. *Nucula Cobboldice* is hitherto known from Japan only." He further on makes the following important observations on the admixture of littoral and deeper-water shells:—"I should be inclined to reject from the list of Bridlington shells the following species, viz. *Mytilus edulis*, *Cardium edule*, *Littorina littorea*, *L. rudis*, and *Purpura lapillus*, because they are littoral, and therefore not likely to be associated with species which belong to the coralline zone, such as *Rhynchonella psittacea*, *Venus fluctuosa*, *Dentalium striolatum*, *Admete viridula*, and *Columbella Holböllli*" (= *C. rosacea*). "These littoral shells may have come from an overlying or adjacent bed, and become accidentally mixed with the shells from the deposit under consideration." It is not uncommon to find on any shore among the littoral shells others that have been torn away by currents and tossed up by storms from far below low-water mark. But in that case Gwyn Jeffreys evidently must have thought, from the character of the deposit and other circumstances, that that explanation was not sufficient.

Mr. Lamplugh has worked this question out, and arrived at the conclusion that some of the shell-bearing beds are transported by the agency of ice from sea-bottoms of various depths further north and mixed up with littoral and even freshwater deposits*. Whether any of them have travelled far or not matters little for our present purpose, as the condition must have been somewhat boreal on a shore thus invaded by ice from arctic regions. I have therefore given the list of the shells as a sample of what we should expect in a true glacial deposit, without noticing the character of bed from which it was derived. For such details I refer to Mr. Lamplugh's excellent

* Geol. Mag. dec. 2, vol. vi. 1879, p. 393.

papers, and especially to the recently published Mem. Geol. Survey, "Geology of Holderness," by Mr. Clement Reid, to whom I am indebted for the revision of my list and for much kind assistance. The percentages have been changed by Mr. Reid's work, and the statements of Gwyn Jeffreys and others will have to be modified; but the main conclusions to which I would draw attention remain unaltered, viz. that "with the Bridlington Crag, notwithstanding the close proximity of the deposits, the marine gravels show little connexion" (Clement Reid, p. 69). I am inclined to refer the glacial character of some of the newer marine beds of Eastern Yorkshire to the wasting of old boulder-clay cliffs and the using up of old material, rather than to the recurrence of arctic conditions, and so compare the Arenig land-ice drift of the west with the Bridlington Drift of the east, and the St. Asaph Drift with the shell-bearing sands and gravels of Kelsea and Hessle.

There is more doubt respecting the fauna of the glacial beds south of the Humber, Searles Wood's Mid-glacial, for instance, in consequence of the difficulty of discriminating between the contemporaneous shells and those derived from the Crag, which occurs close by. (See a useful review of the literature of this part of the subject by H. B. Woodward, Proc. Geol. Assoc. vol. ix. See also Jukes-Browne.)

Table of Distribution of Fossils in Drifts.*

	I.	II.	III.	IV.	V	VI.	VII.	VIII.
<i>Rhynchonella psittacea</i> , Chemn.	*
<i>Anomia ephippium</i> , Linn.	*	...	*	*
<i>Ostrea edulis</i> , Linn.	*	...	*	...	*	*	*	*
<i>Pecten islandicus</i> , Müll.	*	*
— opercularis, Linn.	*	...	*	*	...	*
— pes-lutræ, Linn.	*
<i>Mytilus edulis</i> , Linn.	*	...	*	...	*	*	*	*
— (<i>Modiola</i>) <i>modiolus</i> , Linn.	*	*	...	*	*
<i>Crenella decussata</i> , Montagu	*
<i>Nucula Cobboldiæ</i> , Leathes	*
— nucleus, Linn.	*	*	...	*	*
— tenuis, Montagu	*
— —, var. <i>inflata</i> , Hanc.	*
—, sp.	*	*
<i>Leda intermedia</i> , M. Sars	*
— <i>lenticula</i> , Möll.	*	*
— <i>limatula</i> , Say	*
— <i>minuta</i> , Müll.	*
— —, var. <i>buccata</i>	*
— <i>pernula</i> , Müll.	*	...	*	*	...	*
— <i>tenuis</i> , Phil.	*
<i>Pectunculus glycymeris</i> , Linn.	?	*	...	*	*	...	*
<i>Arca lactea</i> , Linn.	*	*
<i>Montacuta Dawsoni</i> , Jeffr.	*

* Column I. St. Asaph; II. Colwyn Bay; III. Moel Tryfan; IV. Minera &c.; V. Lancashire and Cheshire; VI. Macclesfield; VII. Kelsea; VIII. Bridlington.

TABLE (continued).

	I.	II.	III.	IV.	V.	VI.	VII.	VIII.
<i>Axinopsis orbiculata</i> , <i>G. O. Sars</i>	*
<i>Lucina borealis</i> , <i>Linn.</i>	*
<i>Loripes divaricata</i> , <i>Linn.</i>	*	...
<i>Cardita borealis</i> , <i>Conrad</i>	*
<i>Cardium aculeatum</i> , <i>Linn.</i>	*	*
— <i>echinatum</i> , <i>Linn.</i>	*	...	*	*	*	*	*	...
— <i>edule</i> , <i>Linn.</i>	*	*	*	*	*	*	*	*
— <i>exiguum</i> , <i>Gmel.</i>	*	...
— <i>fasciatum</i> , <i>Montagu</i>	*
— <i>grœnlandicum</i> , <i>Chemn.</i>	*
— <i>islandicum</i> , <i>Linn.</i>	*
— <i>norvegicum</i> , <i>Spengler</i>	*	...	*	*
— <i>tuberculatum</i> , <i>Linn.</i> (= <i>C. rusticum</i>).....	*	*
<i>Corbicula (Cyrena) fluminalis</i> , <i>Müll.</i>	*	...
<i>Cyprina islandica</i> , <i>Linn.</i>	*	*	*	*	*	*	*
<i>Astarte borealis</i> , <i>Chemn.</i> (= <i>A. arctica</i> , <i>Gray</i>).....	*	*	*	*	*	*	*	*
— —, var. <i>Withami</i>	*
— <i>compressa</i> , <i>Mont.</i>	*	...	*	...	*	*
— <i>depressa</i> , <i>Brown</i> (= <i>A. crenata</i> = <i>A. crebricostata</i>).....	*	...	*	*
— <i>sulcata</i> , <i>Da Costa</i>	*	...	*	...	*	*
— —, var. <i>elliptica</i> , <i>Brown</i>	*	*	...	*	*	...	*
<i>Venus casina</i> , <i>Linn.</i>	*	...	*
— (<i>Cytherea</i>) <i>Chione</i> , <i>Linn.</i>	*	*	*	...
— (<i>Artemis</i>) <i>exoleta</i> , <i>Linn.</i>	*	...	*	...	*
— (—) <i>lincta</i> , <i>Pult.</i>	*	*
— <i>fluctuosa</i> , <i>Gould</i>	*
— <i>gallina</i> , <i>Linn.</i>	*	...	*	...
— —, var. <i>striatula</i> , <i>Donovan</i>	*	...	*	*	*	...
— <i>ovata</i> , <i>Penn.</i>	*
— <i>verrucosa</i> , <i>Linn.</i>	*
<i>Tapes pullastra</i> , <i>Mont.</i> (= <i>T. geographicus</i>).....	*	...	*
— <i>decussatus</i> , <i>Linn.</i>	*	...
— <i>virginicus</i> , <i>Linn.</i>	*	...	*
<i>Tellina balthica</i> , <i>Linn.</i> (= <i>T. solidula</i>).....	*	*	*	*	*	*	*	*
— <i>calcaria</i> , <i>Chemn.</i> (= <i>T. proxima</i>).....	*	...	*	...	*	*
— <i>obliqua</i> , <i>J. Sow.</i>	*	*
— <i>pusilla</i> , <i>Phil.</i>	*
— <i>tenuis</i> ?, <i>Da C.</i>	*	...
<i>Psammobia ferroensis</i> , <i>Chemn.</i>	*	*	*	...
<i>Donax vittatus</i> , <i>Da C.</i> (= <i>D. anatinus</i>).....	*	...	*	*	*	*
<i>Mactra glauca</i> , <i>Born</i> (= <i>M. helvacea</i>).....	*	*	*	...
— <i>solida</i> , <i>Linn.</i> (= <i>M. ovalis</i>).....	*	*	*	*	*	...
— —, var. <i>elliptica</i>	*	*	...	*	*
— <i>subtruncata</i> , <i>Da C.</i>	*	...	*	...	*	...
<i>Lutraria elliptica</i> , <i>Lamk.</i>	*	*
<i>Scrobicularia piperata</i> , <i>Gmel.</i>	*	...	*	...
— <i>alba</i> , <i>Wood</i>	*
<i>Solen ensis</i> , <i>Linn.</i>	*
— <i>siliqua</i> , <i>Linn.</i>	*	...	*	...
<i>Thracia prætenuis</i> , <i>Pult.</i>	*
— <i>pubescens</i> , <i>Pult.</i>	*	*

TABLE (continued).

	I.	II.	III.	IV.	V.	VI.	VII.	VIII.
<i>Corbula gibba</i> , <i>Olivi</i> (=C. striata =C. nucleus).....	*	...	*	*	*	*
— <i>pusilla</i> , <i>Phil.</i>	*
<i>Mya arenaria</i> , <i>Linn.</i>	*	*	*	*
— <i>truncata</i> , <i>Linn.</i>	*	*	*	*	*	*	*
— —, var. <i>uddevallensis</i>	*	*
<i>Saxicava norvegica</i> , <i>Spengl.</i>	*	...	*	*
— <i>rugosa</i> , <i>Linn.</i> (=S. arctica)	*	...	*	...	*	*
<i>Pholas candida</i> , <i>Linn.</i>	*
— <i>crispata</i> , <i>Linn.</i>	*	*	*	*
<i>Teredo norvegica</i> , <i>Spengl.</i>	*
<i>Dentalium entalis</i> , <i>Linn.</i>	*	...	*	*	*	*
— <i>striolatum</i> , <i>Stimpson</i> (=D. abyssorum)	*	...	*	...	*	*	...	*
— <i>tarentinum</i> , <i>Lamk.</i>	*	*
<i>Patella vulgata</i> , <i>Linn.</i>	*	...	*	*
<i>Tectura virginea</i> , <i>Müll.</i>	*
<i>Lepeta cæca</i> , <i>Müll.</i>	*
<i>Puncturella noachina</i> , <i>Linn.</i>	*
<i>Fissurella græca</i> , <i>Linn.</i> (=F. reticulata)	*	...	*	*
<i>Trochus cinerarius</i> , <i>Linn.</i>	*	*	*	*	*
— <i>cinereus</i> , <i>Couthouy</i>	*
— <i>grœnlandicus</i> , <i>Chemn.</i>	*
— <i>magus</i> , <i>Linn.</i>	*	...	*
— <i>umbilicatus</i> , <i>Mont.</i>	*
— <i>varicosus</i> , <i>Mighels & Adams</i>	*
— <i>ziziphinus</i> , <i>Linn.</i>	*
<i>Lacuna crassior</i> , <i>Mont.</i>	*	...
— <i>divaricata</i> , <i>Fabr.</i> (=L. vineta)	*	...	*	...	*	*
<i>Littorina littorea</i> , <i>Linn.</i>	*	*	*	...	*	*	*	*
— <i>obtusata</i> , <i>Linn.</i> (=L. littoralis)	*	...	*	*
— <i>globosa</i> , <i>Jeffr.</i>	*
— <i>rudis</i> , <i>Maton</i>	*	...	*	*	*	*
— <i>squalida</i> , <i>Brod. & Sow.</i>	*	...
<i>Menestho albula</i> , <i>Fabr.</i>	*
<i>Rissoa labiosa</i> , <i>Mont.</i>	*	...
— <i>ulvæ</i> , <i>Pen.</i> (=R. subumbilicata)	*	...
— <i>parva</i> , <i>Da C.</i>	*
— <i>subperforata</i> , <i>Jeffr.</i>	*
— <i>Wyville-Thomsoni</i> , <i>Jeffr.</i>	*
<i>Homalogyra atomus</i> , <i>Phil.</i>	*
<i>Turritella erosa</i> , <i>Couth.</i>	*
— <i>terebra</i> , <i>Linn.</i> (=T. communis) ..	*	*	*	...	*	*	*	*
<i>Scalaria communis</i> , <i>Lamk.</i>	*	...	*	...
— <i>grœnlandica</i> , <i>Chemn.</i>	*
<i>Odostomia conspicua</i> , <i>Alder</i>	*
— <i>interstincta</i> , <i>Mont.</i>	*
— <i>rufa</i> , <i>Phil.</i>	*	...
<i>Natica affinis</i> , <i>Gmel.</i> (=N. clausa)	*	...	*	...	*	*
— —, var. <i>occlusa</i>	*
— <i>Alderi</i> , <i>Forbes</i> (=N. nitida)	*	*	*	...
— <i>catena</i> , <i>Da C.</i> (=N. monilifera, <i>Lamk.</i>)	*	*	*	...
— <i>grœnlandica</i> , <i>Beck</i> (=N. pusilla)	*	...	*	*

TABLE (*continued*).

	I.	II.	III.	IV.	V.	VI.	VII.	VIII.
<i>Balanus balanoides</i> , Linn.	*			
— <i>crenatus</i> , Brug.....	...	*	*	...	*	...	*	*
— <i>Hameri</i> , Asc.	*	...	*	*	*	*
— <i>porcatus</i> , Da C. (=B. <i>sulcatus</i> , Da C.).....	*	...	*	*
<i>Serpula</i> (<i>Pomatoceros</i>) <i>triquetra</i>	*	...	*			
— <i>vermicularis</i> , Ellis	*			
<i>Spirorbis nautiloides</i>	*			
<i>Cliona perforans</i> ?.....	*	...	*	*	*	*

PART IV.

Alluvium and Surface-drift.

Now we must briefly examine the still more recent superficial deposits of the Vale. In treating of the drifts this is of great importance, seeing that it is so hard to distinguish the re-sorted newest beds from the undisturbed original deposit from which they were derived. Even in the older rocks this is a common source of error. The compact breccia composed entirely of fragments of Mountain Limestone which sometimes makes up the Brockram or base of the Lower New Red Sandstone in the Eden valley is often almost undistinguishable from the parent rock. The surface of the Lower Chalk broken up and reset has often been mistaken for the solid chalk, until a line of angular flints showed that it was only consolidated chalk-gravel. Re-sorted Miocene has been reported to contain remains of man. But the re-sorted drifts almost defy detection in most cases. We have already discussed the characters which help us to make out whether the glacial drift remains as left by the ice, or whether it has been sorted by the sea; so also, if we know the district well, we may ascertain whether we have before us the marine deposit or only some of it washed to lower levels by rain, or worked down the hill by all the other agencies which modify the surface-soil (see Morton, G. H., 'Nature,' Sept. 30, 1880, p. 511).

It is clear that a long time has elapsed since the last of the St. Asaph Drifts was left by the sea; this is evident, first, from an examination of the newer deposits which have been laid down on it or after it. The various kinds of alluvium which have silted up the lower or northern end of the Vale of Clwyd are all newer and must have taken some time to form. We have already pointed out that in the sections near Rhuddlan they are seen resting upon what looks like St. Asaph Drift.

So we come now to the Alluvial Age. Alluvium and rainwash must, from the nature of the case, have been formed in every period

of the world's history when there were land and rain and streams ; but these superficial deposits would be the first to be destroyed, especially in subsequent submergences, and the chances are that only the latest deposits of that kind are seen exposed in any district.

At any rate the alluvium and rainwash of the Vale of Clwyd belongs to the age that succeeded the emergence, and is still going on.

Patches of alluvium can be traced far up into the hill. For example, down the road between Wern and Penybanc, N. of Ponty-rddol, there is a grey gravel, and here and there beds of sand. It was, so far as I could see, all composed of Silurian and Cambrian rocks.

We have no data for determining the absolute age of the alluvial deposits in the upper part of the Vale. I have a very fine, partly ground neolithic implement, picked up by Mr. Stuart Menteith in the gravel of the Elwy above St. Asaph, and given to me ; but there is no evidence as to whether this was carried on to the gravelly bed of the river from the alluvial gravel which there spread across the valley from side to side, or was dropped in from the surface-soil. The North Wales fenlands of Morfa Rhuddlan were formed where the river spread over the low flat lands ; its velocity was checked, and the transport of gravel ceased. So below St. Asaph, near Rhuddlan and Rhyl, for instance, the gravel banks give way to tidal silt, to which we will refer as the Morfa Rhuddlan beds, and which is probably newer still than some, at any rate, of the gravel near St. Asaph. The course of the river has altered considerably since the water-towers of Rhuddlan Castle were built.

Sections through the silt have been sunk for various purposes here and there. For instance, I was informed that when the railway was being made along the coast, they dug out the blue estuarine clay to a depth of 18 feet to make the embankment, and near the bottom of the excavation found the skull of *Bos longifrons*, and the antlers of *Cervus elaphus*, which are now preserved in the Cambrian inn at Pensarn. These remains occur here and there all through the deposit. The *Balani* on the points of another pair of antlers show that it had projected above the surface of the clay for some time.

On the south of Rhyl a trench cut out for draining-purposes exposed the following section :—

	ft.	in.
a. Surface-soil with broken shells of <i>Buccinum undatum</i> at the base, perhaps artificially carried there.		
b. Blue clay, weathering brown in the upper part, containing shells of <i>Scrobicularia piperata</i> , with valves adherent	1	0
c. Peaty silt, no timber	0	6
d. Peat with trees 15 ft. in length and 1 ft. 6 in. in diameter	2	0
e. Blue clay	3	0

On the Morfa Rhuddlan beds rest the sand-dunes and the shingle which form a great natural bulwark against the sea, which is driven fiercely on this coast by the north-west winds. These Eolian beds

are of any recent age down to the present day ; there is no evidence of any of them being of greater antiquity than the Morfa Rhuddlan beds ; yet it is probable that they were always represented along this shore, and played their part in aiding or checking the changes which submergences or elevation from time to time tended to produce.

There are traditions and some other suggestions of there having been such changes within historic times, though history is silent about them. In the churchyard at Abergele there is a sandstone slab bearing this inscription :—“ Here there lies in the churchyard of Michael a man who had his dwelling three miles to the north.”

The sea is now within a mile ; but whatever may be the interpretation of this statement, whether he was a man who lived on board ship, or whatever other explanation can be offered, it does seem to me improbable that changes of that kind and extent can have taken place along that coast within the period that the character of the inscription would allow us to assign to it, or even since Abergele church was built.

The traditions of change in the coast-line may, however, be founded on correct observation. Very likely, for instance, a tongue of drift ran far out by Llandrillo yn rhos, the destruction of which affected the denudation along the shore further east. Very likely there have been some changes of level in comparatively recent times, and the so-called submerged forests near Prestatyn and Pensarn and at the west end of Colwyn Bay are most easily explained on the supposition of a small subsidence *. But we must remember that trees now grow in the marshes behind the sand-dunes on ground over which the sea would rush in high tides, were it not for the protecting barrier, and that by the washing out of sand below such forest-beds they often get still further lowered, while some supposed forests are mere stumps of trees drifted out to sea and generally floated right side up as they are ballasted by the earth and stones caught in the roots. (See Potter, Trans. Liverpool Geol. Soc. 1868-9 ; Whitaker, Mem. Geol. Survey, Guide to Geol. Lond., 4th edition, pp. 77, 78 ; East Essex, p. 18 ; Geol. Ipswich, p. 97 ; Proc. Geol. Assoc. viii. p. 137. See also Rep. Brit. Assoc. 1885, pp. 442-465.)

The peat of the East Anglian fenland is, in the main, of Neolithic age †, though some of the earlier deposits associated with the peat contain palæolithic animals, for these have been shown to be probably only a few derivative specimens from the older gravel-beds on which the peat rested.

So the peat and silt of the estuary of the Clwyd have yielded nothing older than the *Bos longifrons* and *Cervus elaphus*. The Morfa Rhuddlan beds may date from Neolithic times to the present day. Few short rivers running straight out from the hills to the sea without the intervention of low-terraced lands near the mouth

* Mellard Reade observes that the last movement of the land in Lancashire was downwards (Proc. Liverpool Geol. Soc. 1871-2, p. 437).

† ‘ Cambridge Review,’ 1886, p. 366.

have yielded palæolithic remains. As the river is cutting back the steep ground, terraces are soon destroyed, and the rain and agents of degradation keep handing down to lower levels all superficial deposits as soon as formed—so along such valleys great masses of rainwash, or head, or run of the hill gather in hollow places or on ledges; all surface soils merge into such accumulations. Where the ground is covered by vegetation it is to some extent protected; but where the sod is broken, the rain soon undermines and sweeps out the soil, and a ravine is formed. A hole scraped for shelter by a sheep may let the water through the turf and start the work. Looking out on the east from the train near Lowgill Junction in Westmorland, about an acre of land may be seen covered with stones to about 10 feet deep in places. That was all done in about two hours in a thunder-storm, and the gashes from which this débris was swept out are seen on the fellside above. At the mouth of each little gorge along the Upper Rhone a fan-shaped mass of torrent-débris is protruded into the valley. These look like the fragments of moraines as you drive down the valley over a succession of hills, now hanging on to this side, now to that side of the valley. A more careful examination, however, especially from higher ground, soon shows their real character. So in the smaller valley of the Clwyd there are masses of torrent-débris of postglacial age protruded into the vale, as, for example, out of the gorge by Denbigh, from the valley of the Clwydog, or from the smaller tributary streams. But all the while along the slopes the rain brought down the soil and stones, leaving the rocks bare here and there to be disintegrated and furnish more material.

Such débris, derived almost exclusively from Silurian rock, was pointed out to us by Mr. Strahan in a road-section east of Tremeirchion. Where there is soft drift the rainwash is, of course, different, and is more readily transported; but sooner or later every loose material travels down the hill. Where the soil is bared by ploughing, the downward waste is often very rapid. In every long-cultivated hill-country there are terraces so formed. Each man turns down the soil from the upper side, so it accumulates at the lower end of his allotment, and is removed from the bottom of the bank that separates him from his neighbour on the slope above (see fig. 5, p. 111). Thus, in a manner accidentally, are formed the terraces known as "raines" in the north of England.

There are many tests to apply when we are trying to distinguish between a marine shingle, a river-gravel, and the rainwash or run-of-the-hill.

A marine shingle has the finer and coarser gravel somewhat sorted, but the up incline and the over-bank tip are quite distinct. Even in the case of shingle thrown against a cliff there is often a ridge of thrown-up gravel a little way from the rock; this is caused by the recoil of the wave. Just as we may often notice along the pavement on a gusty day, the dust is laid, not along the base of the wall, but in a ridge nearer the middle of the pavement, being driven off the wall by the rebound of the wind from

it; so it often is in the case of material deposited by currents at the foot of cliffs.

The stones of which the shingle is composed lie with their longer axes parallel to the planes of deposition as a rule; but sometimes when the scour is great they have a subordinate arrangement approaching that next described in the case of river-gravels.

River-gravels are left, as the velocity of the current decreases, in the order in which, from their size, weight, form, and other conditions, they first attain their position of rest; but the principal character common to all such gravels is that the flattened oval forms lie packed together obliquely, with their longer axes inclined to the bed of the stream, the lower end pointing up stream, so that the flat stones overlap one another in such a manner as to present a face to the descending current and throw the water up instead of letting it get under the edge and lift the stone.

Of course all gravels deposited by marine currents have this character also; but there are seldom marine currents of the force and velocity of a mountain-river in flood.

In the case of the *run-of-the-hill*, on the other hand, the stones and other materials are more commonly carried down by movement more akin to slips. The position of rest is not that in which the material can best resist the force of a downward current urging it on, but the position in which it can catch by friction, or by arriving at a gentler slope, so that its own downward tendency is overcome. The flat pieces therefore lie with their longer axes parallel to the surface along which the débris is travelling.

The material is roughly stratified because rain helps, and different material catches in different circumstances. The travelling of isolated boulders in the rainwash or marine drift or on the shore is easily explained. Though gravel, consisting of stones of a given size, requires water of a given velocity to move it, it does not follow that one such stone lying on sand requires water of the same velocity to carry it along. The fine material round and below it is removed by the swifter current close to the obstructing mass; it is set in motion, and the water playing on the whole of one face rolls it along over the even surface of sand. So the occurrence of single blocks can often be explained without calling in the agency of ice or any exceptional condition. All around the Vale of Clwyd such débris is everywhere found, sometimes derived from the solid rock, as in the section above quoted (p. 100), near Tremeirchion, sometimes derived from the drift, as up the road from Pontyralltgoch to Wigfair Uchaf, sometimes red with the washings of the New Red and the result of the decomposition of limestone, and sometimes grey where the iron-oxides have been washed away or the rocks from which it is derived contained originally a smaller proportion.

In the Vale of Clwyd this crumbling of all loose material down the hill-sides has been going on ever since the land emerged from below the waves that left the St. Asaph Drift, through the long ages while the sand-dunes and wave-driven shingle were travelling from west to east and damming the streams that ran into the sea between

Llandulas and Prestatyn, while all the Morfa Rhuddlan beds were being laid down, and while the alluvial gravels of the valley were being formed; each shower, each frost, the sunshine, and the animals all helped to work the surface of the hills to lower levels. With so much time, with such continuous agencies at work, the wonder is that any soft material of early date is left upon the hills.

Where are the deposits of Palæolithic age? Perhaps they may be represented by some of the higher terrace-gravels, which are older than the Morfa Rhuddlan beds, and older than most of the gravels of the Elwy and the Clwyd. But the chances are enormously against our finding any remains of that date in the terrace-gravels along the hill-sides. The implements were rare and the bones were quickly decomposed in those porous water-bearing strata.

It is not as if we had plenty of such remains in the gravels of later date. Were it not for that one flint implement preserved by some accident in the more recent gravel of the Elwy, we should know nothing of the occurrence of neolithic man in the district except from the remains found in caves and from some interments.

Perhaps some of the Morfa Rhuddlan beds may go back to the Neolithic age. The *Bos* and the *Cervus* found in them certainly came down to Roman and later times.

Similar phenomena are recorded from West Lancashire* and Cheshire†.

It is perfectly clear that we cannot everywhere draw a hard-and-fast line between these divisions.

The rain and other subaerial agencies must have brought down the débris of the hill-sides, and the tidal silt was being thrown down in the lower reaches of the Clwyd, while the rivers were forming terraces along the cavernous banks of the Elwy. But little of that which was washed down in the earlier times has not been since removed by the continuance of similar agencies, and none can have survived the scour of the submergence.

So river-gravels were being formed in the upper part of the vale while marine deposits were being thrown down in the lower, and so on; but, in the main, there is a general sequence to be made out, and the relative age is pretty clear, though it will take much more work to feel sure where to place the beds seen in every isolated section.

PART V.

Caves.

We must now examine the evidence to be derived from the caves and endeavour to find their place in the chronology of the district.

With a view to this it is of first importance to distinguish clearly between the history of the *caves themselves* and that of the *cave-deposits*.

* Moore, T. J., Trans. Lancashire Historic Soc. 1885.

† De Rance, Quart. Journ. Geol. Soc. 1871, xxvii. p. 655.

There are many kinds of caves, and there are many different ways in which caves are formed, and it is impossible to investigate their age without inquiring somewhat into the geology and physiography of the district; but I shall dismiss this part of the subject very shortly with a reference or two.

First, we are not dealing with artificial caves in any case, nor with caves formed by the sea. The cliffs in which they occur are not sea-cliffs*. We have to do with natural caves, such as rock-shelters due to the subaerial wasting away of parts of the rock which were readily shelled off under the influence of variations of temperature and of the moisture which was condensed upon it.

The most favourable condition for the formation of caves is that the limestone should have been exposed to the action of the weather and its joints opened out, and that then it should be partially covered up by boulder-clay, which would collect all the water into runlets, and so concentrate it upon certain lines of weakness and form underground watercourses †.

Still more common than the rock-shelters, and more important for our present inquiry, are the caves which represent ancient subterranean watercourses in the limestone rocks which flank the vale on either side. *How* such caves were formed is well known; but *when* they were formed, and to what drainage-system they belong, is not always clear.

For instance, in the Elwy valley the Cefn caves are obviously due to the decomposition of the limestone along the weaker lines in the general drainage-system of that valley; but what the particular local conditions were that caused the subterranean channel to plunge down suddenly to an outlet far below, is not so clear.

The adjoining Pontnewydd cave, so far as yet explored, runs approximately on one level.

Near the top of the opposite hill the Plas Heaton cave must have been formed under quite different conditions. It does not lie in the line of any existing drainage-system; it must be a very ancient cave; perhaps it was formed when the streams that flow down near Llysmeirchion ran at a greatly higher level, the intermediate ground being all filled up with drift, or perhaps when the drift choked up the Elwy valley, as we have seen above was once the case, some of its waters may have found their way into the limestone rocks above Plas Heaton.

If the Cefn caves were formed by water collected on the impervious drift, then we must refer them to a later date than the Plas Heaton cave; but this is not quite certain, as they may have been partly formed when the gorge was first being cut back, and the stream ran partly underground, as now in many limestone valleys, and only in flood ran along the channel of the apparent stream-course. More probably some, if not all, of the Cefn caves were formed much later, when the gorge was filled with boulder-clay, and the water ran into swallow-holes along the margin of the drift and rock,

* See Whitaker, *Geol. Mag.* vol. iv. 1867, pp. 447, 483.

† See Prestwich, *Quart. Journ. Geol. Soc.* vol. x. (1854), p. 222.

and part of such a one became a sloping cave. In the submergence this cave cannot have been *formed*, as nothing would make the current fall to open out vertical passages at the bottom of the sea.

Caves of various age occur along the limestone hills that bound the western side of the vale. Some are old fissures enlarged and filled with various minerals, and being now opened out again, as they are brought within the reach of surface-denudation. Such are the water-caves and lodes exposed by mining along the northern slopes of Cefn Meiriadog.

Further north, upon the coast at Llandulas, caves, now left high and dry in the cliffs above the sea, point to different geographical conditions there; while a little inland the travertine below Cefnyr-Ogof tells of the same process carried on to later times along the margin of the drift-covered hills.

Crossing to the eastern side of the vale, the fissured cavernous limestone of Gwaenysgor and Dyserth has only less conspicuous caves, because there are smaller areas of impervious beds above on which the water could collect in streams.

But near Tremeirchion the conditions are more favourable. About half a square mile of limestone rising abruptly from the valley is surrounded on the east and north and south by the Silurian hills, and the water in every little ravine where it touches the limestone tends to form swallow-holes and caves. The drift, too, overlaps the limestone and carries the water further on to it in places. When the gorge was deepened, the old caves were deserted, and the streams burst out at lower levels. Such caves are quickly choked; for the hills are steep, and there is much drift and loose superficial débris being washed down.

One such ravine which runs down from Y Graig by Ffynnon Beuno is full of caves on either side. Some probably were formed when first the water touched the jointed rock in the bed of the little stream. Some in much later times were fed by swallow-holes along the margin of the drift, which was and is still being eaten back by surface-denudation. None of these are necessarily very ancient caves, as we inferred the Plas Heaton and Cefn caves must be. The upper cave, known as the Cae Gwynn cave, was probably fed by a swallow-hole on the margin of the drift above the upper entrance; and from the lower cave you can now look out at the sky above through an ancient swallow-hole which caught the water off the drift-covered slope.

In the valley of the Chwiler, a little further south, we have an interesting proof that the waste of the limestone rocks and the formation of subterranean watercourses was still going on long after the sandy drift was formed.

Near Caerwys Station, behind the inn which takes its name from the white water of the pool, Pwllgwyn, there is a section through a great mass of travertine which has been deposited against a mound of drift. The travertine is shown to be newer than the red sand and gravel, and to have been deposited against a steep slope of it,

as they dovetail into one another, and lines of red sand seem often to have been washed far out on to the growing travertine. Where this drift overlaps the limestone it must be washed into the crevices and caves which are being formed, as the result of the chemical solution of which we see the proof in the deposit of calcareous tufa at Pwllgywn*.

PART VI.

The Cave-deposits.

The age and manner of formation of the deposits in the caves is quite a separate question from that of the age and manner of formation of the caves themselves.

As a general rule, we may say that the time of formation of caves was a time of destruction. Ever increasing streams were rushing into and through the cave as it was being enlarged, and of course but little deposit of that date could permanently remain. It was when the cave had been deserted by the streams that formed it that the age of accumulation of cave-deposits began. For a long time it was still subject to overflow and flood, and the earlier deposits always ran a great chance of being swept out.

Such a cave, brought within reach of the action of the sea, would be soon cleared out, and every tide would swill it out afresh.

When we try to fix the date of cave-deposits we must appeal to the same kind of varied evidence as that on which we base our classification of the sedimentary rocks in a natural system.

We must from an examination of the district try to make out when it was that the local conditions first allowed any deposits to be laid down in the cave, and establish their true order of succession.

We must also examine the palæontological evidence. The deposit may be very recent, yet contain remains not now common in the area from which it was derived, as for instance when a district has been cleared of wood, and the land-shells and other forms of life have changed in consequence, the cave-deposit may tell the story; we should find those forms of life that haunt the woodland succeeded by those that love the open ground. Without taking such circumstances into account, and making due allowance for habit and habitat, percentage is a very unsafe test in palæontology; still, when we are dealing with bone-caves in which great beasts of prey have gathered the remains of all the animals they fed upon, we have the record of many of the forms of life that do not usually frequent caves, and we can compare the list with those drawn up from all the bones found in the ancient river-gravels and old marine deposits, and can tell whether they most resemble the older or the newer groups of life. In this way sufficient evidence has been collected to form a rough chronology to which we can appeal in isolated cases for a date.

Now let us turn to some of the caves in the same district, and see what we can learn from an examination of their contents.

* See Maw, Geol. Mag. vol. iii. p. 253.

First, I will take Plas Heaton. This I explored with the late Mr. John Heaton. The existence of the cave had been long known. It was exposed in opening a quarry, and the broken rock and fallen drift and rainwash round the mouth were by degrees removed. On removing an old wall built across the mouth by earth stoppers we could then get in a little way. The slope of the soil was inwards at the end next the house, showing that the infilling of that part was chiefly from the mouth behind the increasing barrier of rock-débris and washed clay. It rose again towards the far end. A large number of bones occurred in the first part, and the earth was excavated and laid on the land. Among the bones were those of Hyæna, Dog, Wolf, Fox, Glutton, Bear, Badger, Reindeer, Sheep, and Rabbit.

The lower jaw of Glutton I picked up myself, as it was thrown out by a workman who was digging in the cave. Not far from it were pieces of a large bottle, like a magnum, buried in the earth beyond where we could creep before the excavation had commenced. These had probably been thrown in, and appeared to have got so far, partly by being carried on by the rain, partly because this part of the cave had rapidly been filled, and partly because the earth had been disturbed by badgers and other burrowing beasts. We found the skeletons of two badgers and two dogs all together in one place as if two hounds had got into a badger-earth and all had perished together.

When this cave had been further excavated, bones became very scarce, and the cave ended off in a great mass of red clay with boulders, slipped masses and washed débris from the St. Asaph clay-drift, which lies above. Had we come first upon this cave by digging from the end still unexplored, some would have said it was a preglacial cave, and that its mouth was sealed by Boulder-clay.

In the deepest part of the cave, in the hollow between the accumulations drifted in from either entrance, there was a mass of very fine chocolate-coloured clay, in places finely laminated. This was evidently due to the settling down of the finer sediment washed in through crevices when the cave was nearly choked.

When great storms no longer flood a cave, but the rain still causes a pond of muddy water here and there within it, we find that laminated clay is formed. No stream or wind stirs the quiet water in the deep recesses of the cave, nothing but a falling drop breaks its smooth surface; the mud settles down, first the coarser, then the less coarse, and last the very finest. So as there is a parting of coarser material between every layer of fine, the result is a laminated clay, the thickness of each layer depending partly on the depth and partly on the turbidity of the water which filled the hollows.

The lamination is caused by the alternations of wet and dry weather; but as long as the basin does not vary appreciably in depth, and the amount of sediment in the water is the same, the lamination must be approximately regular, whatever the intervals

between the periods of deposition may be. There is no necessity for calling in glacial action or any conditions different from what commonly now recur in caves periodically invaded by muddy water to account for laminated clay.

The Cefn caves were first described by Dr. George Cumming, of Dolhyfryd, near Denbigh (see 'Llandudno, A Handy Guide, &c.,' by J. Price, p. 80).

They have since that time been frequently noticed:—Stanley, Edin. New Phil. Journ. vol. xiv. 1833, p. 40, Proc. Geol. Soc. vol. i. p. 402; Bowman, J. G., Brit. Assoc. 1836, Rep. Sect. p. 88; Falconer, Pal. Mem. vol. ii. p. 541; Anon., 'Geologist,' 1863, p. 114; Dawkins, 'Cave Hunting,' p. 286.

In a discussion before the Society (Quart. Journ. Geol. Soc. vol. xxvii. p. 410) Mr. Symonds explained the manner of occurrence of the shells in those caves, and I stated that I inferred, from what I had myself observed, that they were all introduced with the rain-wash through fissures &c. from overlying beds of shell-bearing drift.

The Pontnewydd cave, near Cefn, I described* some years ago, in conjunction with my friend Archdeacon Thomas. With regard to the traces of human handiwork we said:—

“On the whole, therefore, it would appear that we have fragments of the toughest stone of a country where suitable flint could not be procured, shaped like some of the undoubted flint implements of the caves of Dordogne, occurring in a cave associated with the same group of animals as that found with the French implements; that these instruments are formed of fragments of flintstone such as is abundant in the drift of the neighbourhood and in the cave-deposits. A portion of the original surface left on some of the implements shows that they were formed out of such weathered fragments. Unless, therefore, the fragments from which the implements were formed were brought by man from another and distant river-basin, they must have been obtained from the drift, and this is rendered almost certain by their being found associated with remanié drift mixed with tumble from the roof of the cave. Therefore they must belong to a period later than the glacial dispersion of the Snowdonian drift. Flint flakes and scrapers have been found in the cave; and pieces of undressed flint certainly occur in the older beds (c), which would make it at any rate of not earlier date than the St. Asaph drift.”

I have often worked in this cave since then, and added much to the collection and the evidence, but see no reason to depart from the conclusions at which we then arrived. I referred the bones to Professor Busk, who wrote to me as follows:—

“I have looked over the collection of bones and teeth from Pontnewydd cave, and find they belong to *Hyaena spelæa*, *Ursus spelæus*, *U. ferox*, *Equus caballus*, *Rhinoceros hemiteochus*, *Cervus elaphus*, *C. capreolus*, *Canis lupus*, *C. vulpes*, *Meles taxus*, *Homo sapiens*, besides indeterminable or not easily determinable splinters, many of

* Journ. Anthrop. Inst. vol. iii. 1874, p. 390; see also Brit. Assoc. Rep. 1881 p. 700; Mackintosh, Quart. Journ. Geol. Soc. vol. xxxii. 1876.

which appear to be gnawed by Hyæna or Wolf. Some are rather less infiltrated with manganese than the others, but all appear to be pretty nearly of the same antiquity, not excepting the human molar tooth, which looks quite as ancient as the rest. It is of very large size, and in this respect exceeds any with which I have compared it, except one or two from Australia or Tasmania."

Here was a cave in which we could not only prove that the deposits were postglacial, but even that they were later than the marine drift which we call the St. Asaph beds; and in these cave-deposits were remains of man—a human molar and stone implements of the oldest type yet recognized in the caves of the Vezère (see figs. 1–8, pl. ix.). These are all of felsite, except figs. 7 and 8, which are of chert and flint. It would be very curious if we elsewhere, in the same district, found a cave which contained the same or a newer group of animals and traces of man's handiwork, and which yet turned out to be of Pliocene or Preglacial age.

A similar investigation recently carried on in the caves near Tremeirchion has led Dr. Hicks* to a different conclusion from that at which I had arrived as to the age of the deposits. Dr. Hicks's graphic descriptions, which have been recently laid before the Society, render it unnecessary for me now to do more than call attention to the points bearing immediately upon the age of the deposits in these caves.

Inside, and more especially at the mouth of, most caves there is a breccia, consisting of angular fragments which have fallen from the rock while the cave was exposed to changes in the amount of moisture and in the temperature. Sometimes the mouth is blocked by a perfect barricade of large masses which have fallen from the face of the rock where most exposed. This was very conspicuous at Plas Heaton; at Ffynnon Beuno, however, the fragments were small. They are generally packed in cave-earth, some of which is the red earthy residuum of the decomposed limestone. In the Cae Gwynn cave, that is the upper cave of Ffynnon Beuno, this limestone breccia contained a few bones; and just within the upper mouth of the cave, under a projecting mass of rock which was removed with a view to making steps up to the surface of the ground outside, a flint flake was taken out from sandy clay in the interstices of the limestone breccia in which bones occurred. It was found under a mass of rock which nearly touched the floor and had to be removed to facilitate operations; and the place where it lay was more like a side crevice in the limestone into which it had been washed or worked down than part of the regular cave-deposits. A similar deposit extended under the sandy drift with boulders, as far out as the excavation was carried.

I do not dispute the genuineness of the flake, nor question its occurrence in the cave. The animals found with it belong to the same group as that which is elsewhere undoubtedly associated with palæolithic man, and it would be enough if glacial deposits could be

* Nature, vol. xxxiv. 1886, p. 216; Proc. Geol. Assoc. vol. ix. 1886; Quart. Journ. Geol. Soc. vol. xlii. 1886, p. 3; Brit. Assoc. 1886, Rep. Sect.

proved to have sealed up a cave containing the remains found in the Ffynnon Beuno caves.

But as a question of evidence, we must remark in passing that the flake and bones outside the cave occurred just where the swallow-hole must have descended which fed the upper entrance to the upper cave before it was quite choked up.

The real point of interest is this:—the north-west end of the cave was blocked by drift, and what appeared to be part of the ossiferous cave-deposit extended over the ledge outside the cave and was covered by the drift. What drift was this?

Referring to the table of the drifts, p. 73, I first explain that it cannot be the Arenig Drift, because it contains flint and north-country boulders. It cannot be earlier than the St. Asaph Drift, which is marine-postglacial, and contains no scratched stones except those derived from the preexisting boulder-clay.

This settles the first and most important question. *Even if the cave were sealed by the St. Asaph Drift, the deposits in it would not be preglacial.*

But can it be the undisturbed marine St. Asaph Drift? I think not. I have shown that the marginal deposits of that age, where they can be observed, are sands and gravels, such as we might expect upon a rocky shore, and such as we see now being formed along the North Wales coast—such as are seen up the very same ravine near the limestone rock between Y Graig and Cae Gwyn.

The deposit outside the Cae Gwyn cave consists of fine sand with earthy patches and scattered boulders, of such a character and arranged in such a manner as would result from the working down the slope of surface-débris from the drift.

The cave-deposits of Plas Heaton or Cae Gwyn cannot belong to the period of submergence; for there is no great upsloping bank of shingle, such as may be seen in any cave reached by the tide; nor would such a sea-cave have been the haunt of man or of the hyæna.

It is quite impossible that whether during the occupation of the cave, or during a later submergence, the lashing waves on a rock-bound shore exposed to the north-west winds should not have swept away all loose débris into the fjord below.

That is probably why we have not yet, and possibly may not in any such situation, find the cave-deposits of the age just before the submergence. Such a cave as Cae Gwyn would have been swilled out, and the ledges in front of and around it swept quite clean by every tide, and the washed-out drift would have settled down in the depths below, beyond the reach of the wind-waves and shore-currents.

If, then, the cave-deposits cannot have been formed before the submergence, because rocks first brought into the district during the submergence are found in the drift at the mouth of the cave, and débris from this drift is found in the cave, and if further, from the character and distribution of the cave-deposits, they cannot be due to marine action during the submergence, it follows that they

must be referred to an age *subsequent to the emergence*; but how much later there is nothing save the palæontological evidence to show.

There has been no glacial action in the vale since the age of the emergence, when the Talargoch gravels were formed, nothing but the denudation by rivers and, on the higher slopes, by rain and sub-aerial degradation. And even if we must assign the palæolithic remains in the cave to the age of the deposit that blocks the mouth, there is no reason why there should not be bones in a cave of the age of the submergence. On the contrary, there is a great deal of evidence of more or less value pointing to the occurrence of bones in these and similar marine-drifts. (See Hughes, Proc. Soc. Nat. Sci. Chester, pt. 3, p. 31; Strahan, Mem. Geol. Surv. Expl. Quart. Sheet 79, N.W. p. 33. In the Hessle and Kelsea Beds, see Phillips and Prestwich and other references given below). There is often a difficulty in making out what the beds are from which bones have been recorded (*e. g.* Tindall, 'Geologist,' vol. i. 1858, p. 493, vol. iii. 1860, p. 119; Geol. Mag. vol. i. 1864, p. 142. In S. Staffordshire, Jukes's 'S. Staffordshire Coal-field,' 1859, p. 207; in beds in which were also sea-shells, see Lister, *op. cit.* p. 162). And if the drift that finally closed the mouth of the cave and overlapped the bones outside it is only the run-of-the-hill, we must remember that it is nothing new or unexpected that rainwash and limestone talus should contain the remains of palæolithic man and other animals. On the slopes of Mont Salève, south of Geneva, flint flakes were found in abundance in such talus, associated with bones of reindeer, &c.

But if ever we come upon Preglacial caves we may expect Pliocene animals; and if we find caves belonging to an age anterior to the great submergence, it is probable that the animals whose remains are found in them will belong to an older group than those found in deposits later than the submergence.

We have not, however, an older group in the Ffynnon Beuno cave. We find there the animals of the newer postglacial gravels of the south and east of England. We have *E. primigenius* not *E. antiquus*, *R. tichorhinus* not *R. megarhinus*, *C. tarandus* and *C. megaceros* not *C. verticornis* and *C. Sedgwickii*.

The list drawn up by Mr. Davies* is as follows:—

Felis leo, var. spelæa.	Bos or Bison.
F. catus ferus.	Cervus giganteus.
Hyæna crocuta, var. spelæa.	C. elaphus.
Canis lupus.	C. capreolus.
C. vulpes.	C. tarandus.
Ursus, sp.	Equus caballus.
Meles taxus.	Rhinoceros tichorhinus.
Sus scrofa.	Elephas primigenius.

(See:—Dawkins, 'Cave Hunting,' 'Early Man in Britain,' 1880,

* Quart. Journ. Geol. Soc. vol. xlii. (1886) p. 17.

Quart. Journ. Geol. Soc. vol. xxiii. p. 108, vol. xxiv. p. 515, vol. xxv. p. 213, vol. xxviii. 1872, p. 410; Searles Wood, Quart. Journ. Geol. Soc. vol. xxiii. p. 394, Geol. Mag. vol. iii. pp. 57, 99, 348, 398, vol. ix. 1872.)

If, then, the drift that hangs upon the slopes above Ffynnon Beuno and chokes the mouth of the caves must be later than the emergence which left the Talargoch gravels, what can it be? It is not a river-deposit. If the Vale of Clwyd was ever filled from side to side up to that level by the old western drift, that drift was cleared out during the submergence, and there is no reason for believing that the valley was ever so filled again. Thus there was nothing for rivers to have run upon at that high level. Its character and

Fig. 5.—View of Old Fence, Ffynnon Beuno.

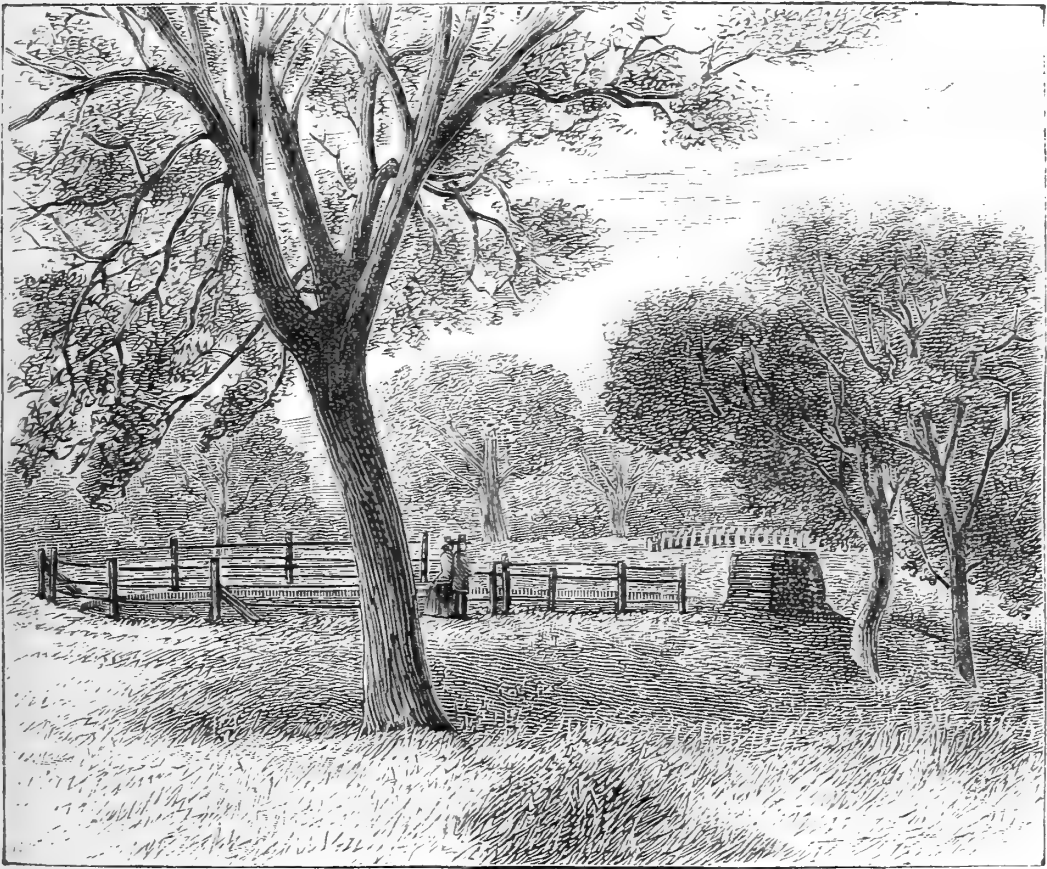

arrangement also prove that it is not alluvium or the torrent-débris of the ravine.

In the Plas Heaton cave the mass of drift overlying the north end of the cave is very like the upper St. Asaph Drift, and is probably derived directly from it; but in the case of Cae Gwynn cave I do not think this is the case. The material that I saw in the section close to the rock where the earth had fallen in did not appear to me to resemble any known section in the undisturbed St. Asaph Drift. It is quite unlike the great masses of red sand exposed here

and there in the Wheeler valley. There is nothing in the sections below the Mount or at Brynelwy at all resembling it. It is not like the drift of Wigfair Isaf or the variable deposits of Wigfair Uchaf, except in each case the obvious top few feet of rainwash. It is like the mixed mud and sand and gravel which we find everywhere overlying the St. Asaph Drift, crumbling down the hill-sides and conforming to the slope of the ground. There is no sorting of the material, as we should expect if currents ran along the rock-face or waves dashed against it; but there is, here and there, an obscure and gentle false-bedding from the cliff as of rainwash creeping down the slope.

All over the slope above Ffynnon Beuno the superficial deposits are creeping down the hill-sides, hanging on every ledge and catching on every obstacle. Any old fence proves how rapidly this process is going on; one such fence ran across the bottom of the field in which the northern end of the cave comes out, passing up to the edge of the precipice, about 16 feet from where the drift fell into the cave.

There we see (fig. 5, from a photograph by Mr. A. D. Walker) that the "head," or travelling talus, has been banked up on the upper side of the hedge, so that there is a fall of some 8 feet from the field on the upper side of the fence to the natural level below it, which also has been lowered by the general working of the soil down the slope. In the sketch the stack of sods lies on the top of this old fence; the tree grows out of the side of it. This superficial talus is the upper part of what has been dug through at the upper mouth of the cave, beyond the two persons standing by the rails, yet it has not been distinguished as different from that which has by some been taken as part of the main mass of the drift; and rightly so, I think. It is all a *remanié* material.

If, after an inspection of the ground, any doubt remained as to the recent age of some, at any rate, of the material which covered the northern mouth of the cave, and which has been by some all equally referred to glacial drift, a more careful inspection of the glaciated stones out of the mass should dispel it. There were plenty of glaciated stones, such as may be found everywhere along the flank of the hill; but some of these, in addition to the more or less well-preserved glacial striæ, carried the deep, rough, irregular grooves of agricultural implements. The tilled soil and the rainwash rapidly accumulate on ledges and against fences on the steep slopes of the Clwydian range. Similar terraces may be seen close by in the second and third field above the road east of Brynbella.

The absence of shells in any of these deposits, so far as negative evidence is of any value, may be explained on the supposition that the beds have been much modified, if not transported some distance down hill, by subaerial action. Fragments of shells are found not uncommonly in the St. Asaph Drift, along the rivers Clwyd and Elwy, but not in the deposits about the Ffynnon Beuno caves. Moreover, the surface of the limestone fragments was decomposed in the drift outside the cave, leaving the less soluble bands sticking out

in sharp relief and showing a chemically fretted surface, not such as is seen on stones rolled in a current, though common on those found travelling in rainwash. This proof of the action of acidulated water makes it probable that, had there been shells in that drift, they would have perished altogether, leaving no trace.

The surface of the solid rock over and round the mouth of the cave was similarly weathered, and the deep undercut ledges are such as are commonly found along all cliffs of the Mountain Limestone when exposed to chemical and ordinary subaerial weathering, and not rounded off by breakers or by ice-action. There was no trace of smoothing by ice.

The scratched stones from the west prove nothing. There can have been no man or hyæna there when the ice-sheet from Snowdon and Arenig carried morainic matter across the Vale of Clwyd.

There are no scratched stones among the rocks peculiar to the drift of the submergence. All the glaciated stones in that are derivative; they are washed from old Arenig and Snowdonian drift into the St. Asaph Drift and into the rainwash, and are being handed on still. On the coast at the present time they are seen, still retaining their striations, some distance from the drift from which they have been derived.

We must remember, too, that the drift blocked only one end of the caves of Plas Heaton and Cae Gwyn, so that there is no difficulty about the manner of occurrence of any of the objects except those in and under the drift at the upper entrance in each case.

PART VII.

Conclusion.

To sum up, I offer the following tentative classification of the principal drifts of the Vale of Clwyd. I place the Talargoch gravels above the St. Asaph clay and sands. The surface of the ground at Talargoch is at a considerably higher level than St. Asaph, and mining-operations have proved the gravels to extend to a much greater depth than the level of the river below St. Asaph; but the central parts of a submerged valley would not receive such rapid additions from the denudation of the surrounding area as would gather along the shore. If we ever recognize the equivalents of the Talargoch gravel near St. Asaph it will probably be, as suggested above, in the upper gravel and sand of the section south of Brynelwy.

Classification of the Drifts of the Vale of Clwyd.

Recent.	A. Rhyl Beds.	Sand-dunes and Shingle.		
Alluvial.	B. Morfa Rhuddlan Beds.	<i>Scribicularia</i> -clays; Estuarine Silt; "Submerged Forests," &c.	Age of Submergence.	Current age.
Alluvial.	C. Newer Elwy Gravel.	Gravel of the Lower Terraces of the Clwyd and Elwy.	Age of Emergence.	Infilling of Plas Heaton Cave. Infilling of Ffynnon Beuno Caves. Formation of Ffynnon Beuno Caves. Infilling of Cefn Caves. Formation of Oefn and Plas Heaton Caves.
Paleolithic.	D. Older Elwy Gravel.	Gravel of the Upper Terraces of the Clwyd and Elwy; the Denbigh Torrent-deltas, &c.	Age of Submergence.	
MARINE.	E. Talargoch Beds.	Ancient shingle of Talargoch, St. George, &c; sea-shells.		
Pre-human.	F. St. Asaph Drift.	Clay, Sand, and Gravel of St. Asaph; sea-shells; fragments of flint and north-country rocks, none stri- ated, except boulders derived from G.		
GLACIAL.	G. Arenig Drift.	Boulder-clay; material all from west; striated boulders; no shells.	Age of Ice.	

There have been many previous attempts to prove the occurrence of remains of Man in Miocene, Pliocene, and Glacial beds; and before this it has been contended that certain cave-deposits were of preglacial age, because a mass of clay with boulders blocked the mouth—for instance, in the Victoria Cave near Settle, where a large group of animals, such as occur elsewhere along with Man, were found in beds overlapped by boulder-clay which had sealed up the mouth of the cave. It was at one time supposed, from wrong determination of a very obscure fragment, that a fibula of Man himself had been found among them; and well there might have been, for they were palæolithic animals. I organized the committee for the exploration of this cave, and watched the excavation at intervals from its commencement, so I had every opportunity of forming an opinion as to the age and mode of formation of the deposits; and “I hold that as the cliff fell back by wet or frost, and limestone fragments fell over the cave-mouth, with them also came masses of clay, which since the glacial times had laid in hollows in the rock above. We dug and found such there, and, more, I observed that the clay lay across the mouth, as though it had thus fallen, and not as if it came direct from glacial ice that pushed its way athwart the crag in which the cave occurs. It seemed to have fallen obliquely from the side where the fissured rock more readily yielded to atmospheric waste, so that it somewhat overlay the part immediately above the cave. On the inside the muddy water which collected after flood, held back by all this clay, filled every crevice and the intervals between the fallen limestone rock, while still outside was the open talus of angular fragments known as screees”*.

Mutatis mutandis, we have the same story over again at Ffynnon Beuno.

Man followed hard on the receding glaciers; but before the ice filled our valleys there is as yet no evidence that Man had visited the north-western part of Europe or our island, if it was an island then.

I do not for a moment deny the possibility or even probability of our some day finding a cave which was formed before the great St.-Asaph-drift submergence, or even before the Great Snowdonian ice rode over the Vale of Clwyd on to the Cheshire plains; but such caves will be few, and their age hard to prove, for many will have been altogether destroyed by denudation, or will have got swilled out by marine and subaerial currents, and no trace of their first inhabitants will have been left. The question is one of such great interest that we are justified in asking for very clear evidence in each case in which it is stated that human remains of great antiquity have been found in caves.

* Victoria Inst., March 1879.

EXPLANATION OF PLATE IX.

On Plate IX. are figured, natural size, the principal types of implements found in Pontnewydd Cave. Nos. 1 to 6 are made of a greenish-grey felstone, probably a fine compact ash; no. 7 is of a black cherty material; no. 8 is of flint, weathered a yellowish white.

- Figs. 1, 1 *a*. A roughly pointed, wedge-shaped, felstone implement on which, at the broader end, a large piece of the original surface of the stone remains, showing that it was manufactured from a drift specimen and not from rock in place.
- 2, 2 *a*. An oval, double wedge-shaped felstone implement, resembling a form I have obtained from the cave of Le Moustier, but more common in the river-drifts.
- 3, 3 *a*. Another of the same type as No. 1.
4. A subquadrate, flat, felstone instrument, approaching the common Le Moustier form. One end of this specimen is covered with travertine.
5. A quadrate, flat, felstone implement, of a common Le Moustier type. The corners appear to have been used rather than the edges. One part of this specimen shows the original surface of a drift stone.
6. A rough felstone scraper; the side not shown in the figure is nearly flat.
- 7, 7 *a*. A flake of black cherty rock, might be a Carboniferous chert.
- 8, 8 *a*. A curved scraper-flake of flint, showing the bulb of percussion and weathered to a yellowish-white colour.

DISCUSSION.

Dr. HICKS said he was entirely unbiassed when he commenced his explorations in the caverns referred to, and would gladly have agreed with Prof. Hughes's views concerning the caverns in the Vale of Clwyd if that had been possible. He had, however, found that all the facts were entirely opposed to the views advocated by Prof. Hughes, and consequently he was unwillingly compelled to disagree with the conclusions arrived at by him. The facts were perfectly clear and had been accepted by every one who had visited the caverns, except by Prof. Hughes. The latter did not see the section at the Cae Gwynn cave until it was almost entirely closed up; and he had also confounded the mixed material placed against the fence by the men in the earlier explorations, as was evident from the diagrams exhibited, with the undisturbed drift, and had based some of his arguments on this mistake and on an ice-scratched boulder on which there was the clearest evidence of its having been recently struck by a workman's pick. The fence-argument was valueless in any case, as it could only affect the surface-deposits and not those shown by the speaker to block up the entrance at a depth of 20 feet.

The Arenig Drift is not necessarily the oldest, in places it may even be the newest, and it is known from well-sinkings to be underlain by sands and gravels like those at Talargoch, in which bones of animals similar to those found in the caverns were discovered. The speaker cited evidence from numerous areas to prove that the oldest drift contained northern erratics, and said that no hard-and-fast lines

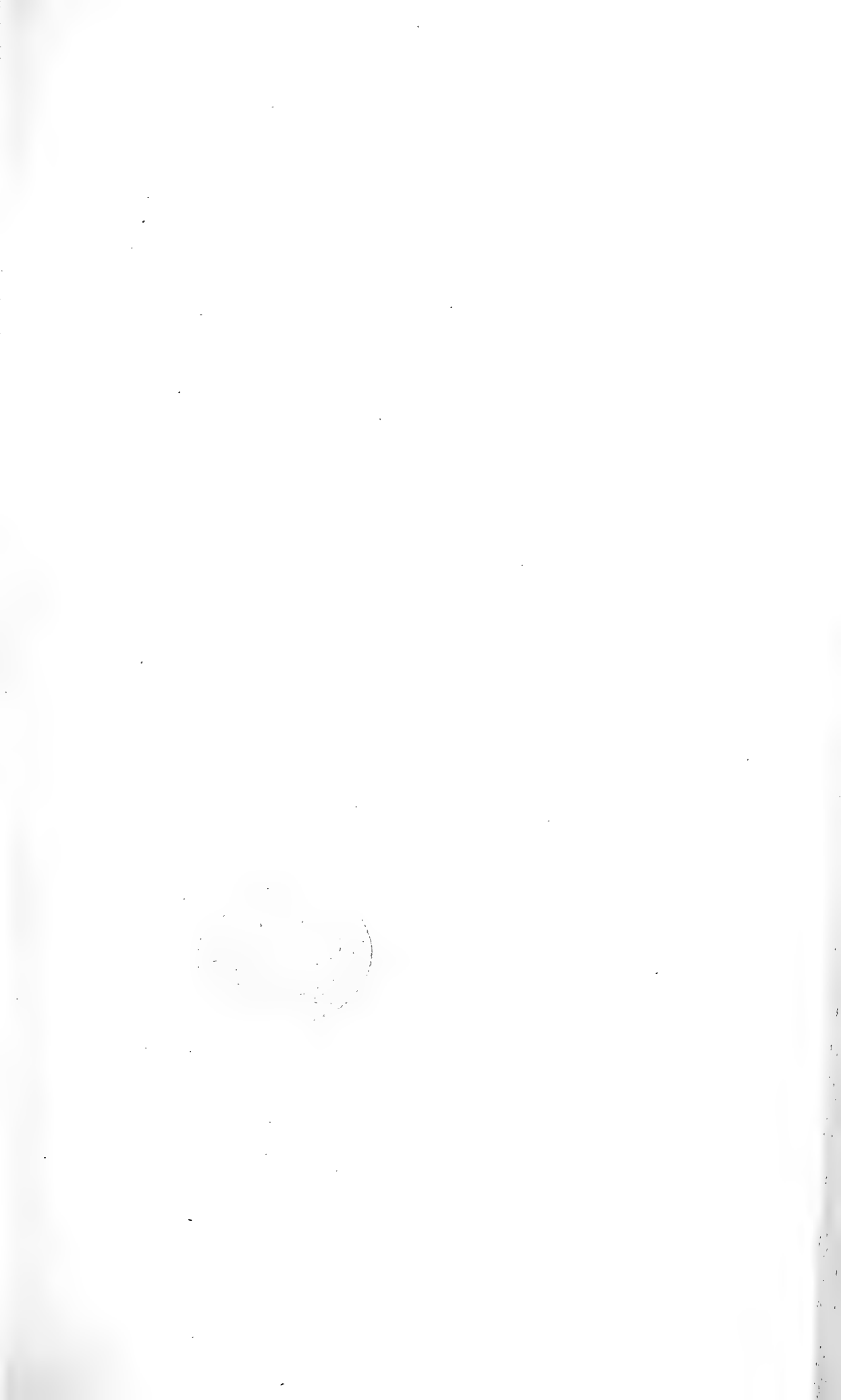

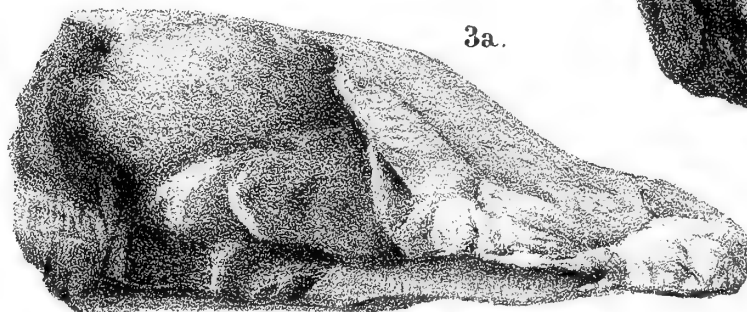
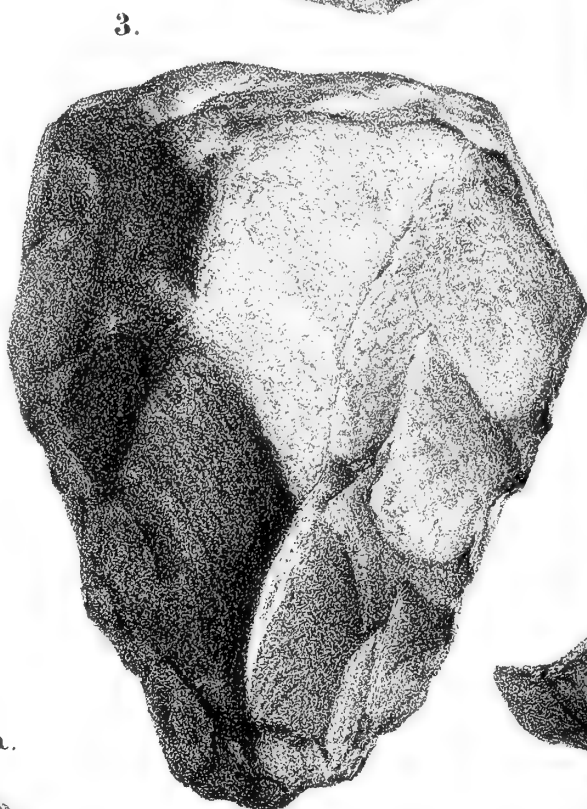
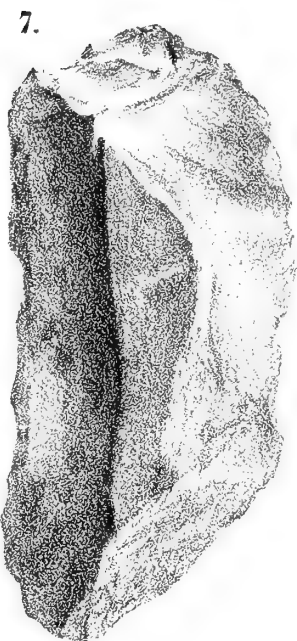
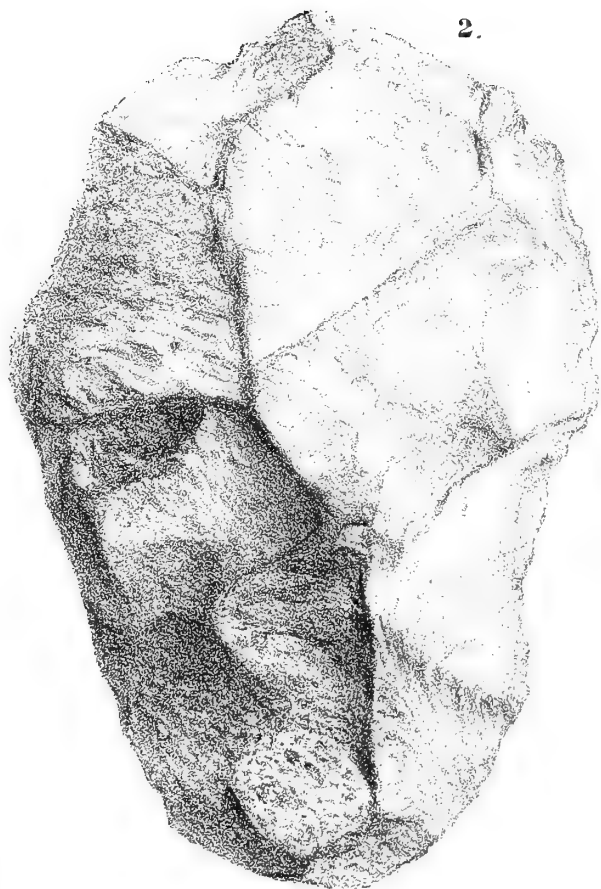

bael del et lith.

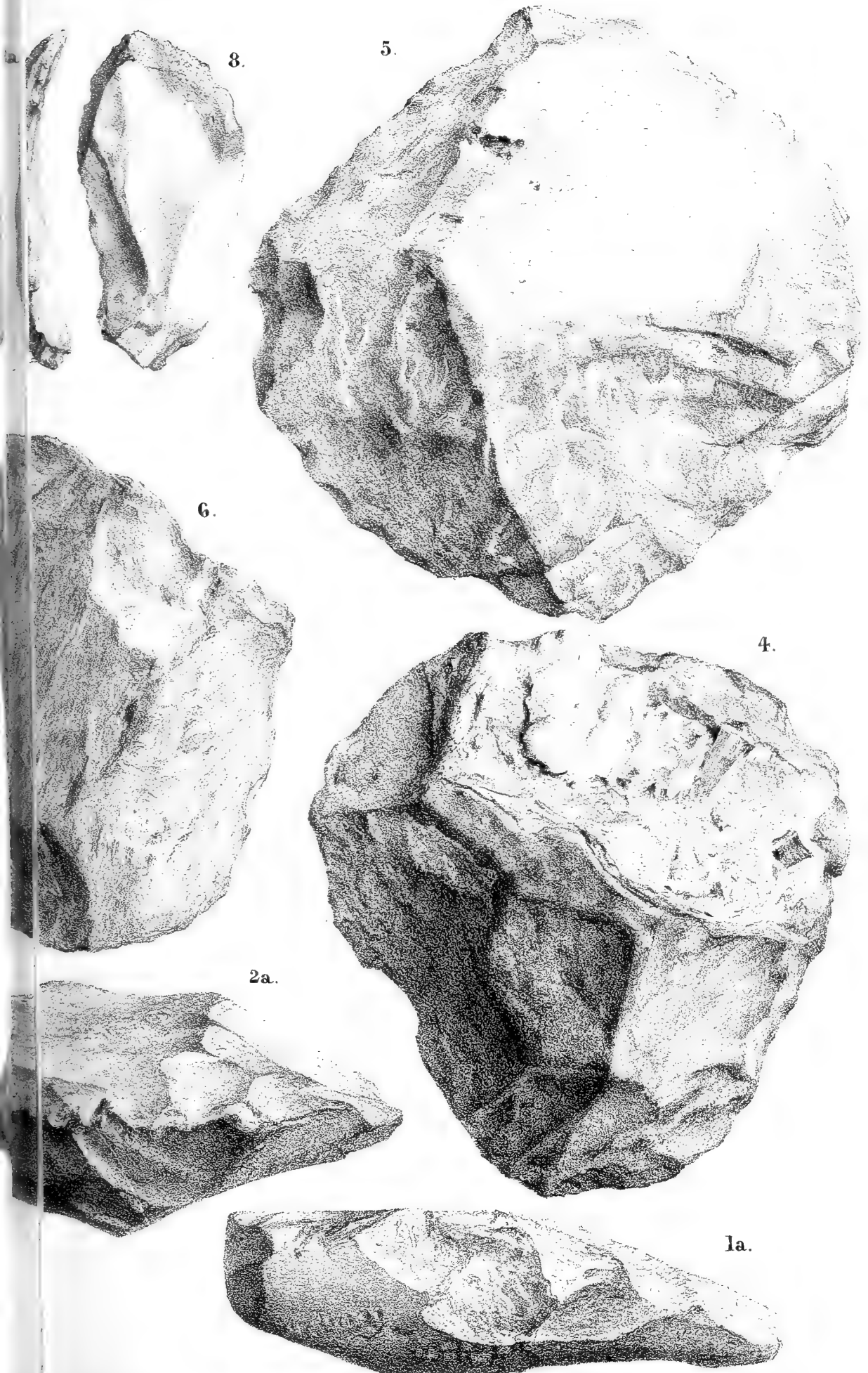

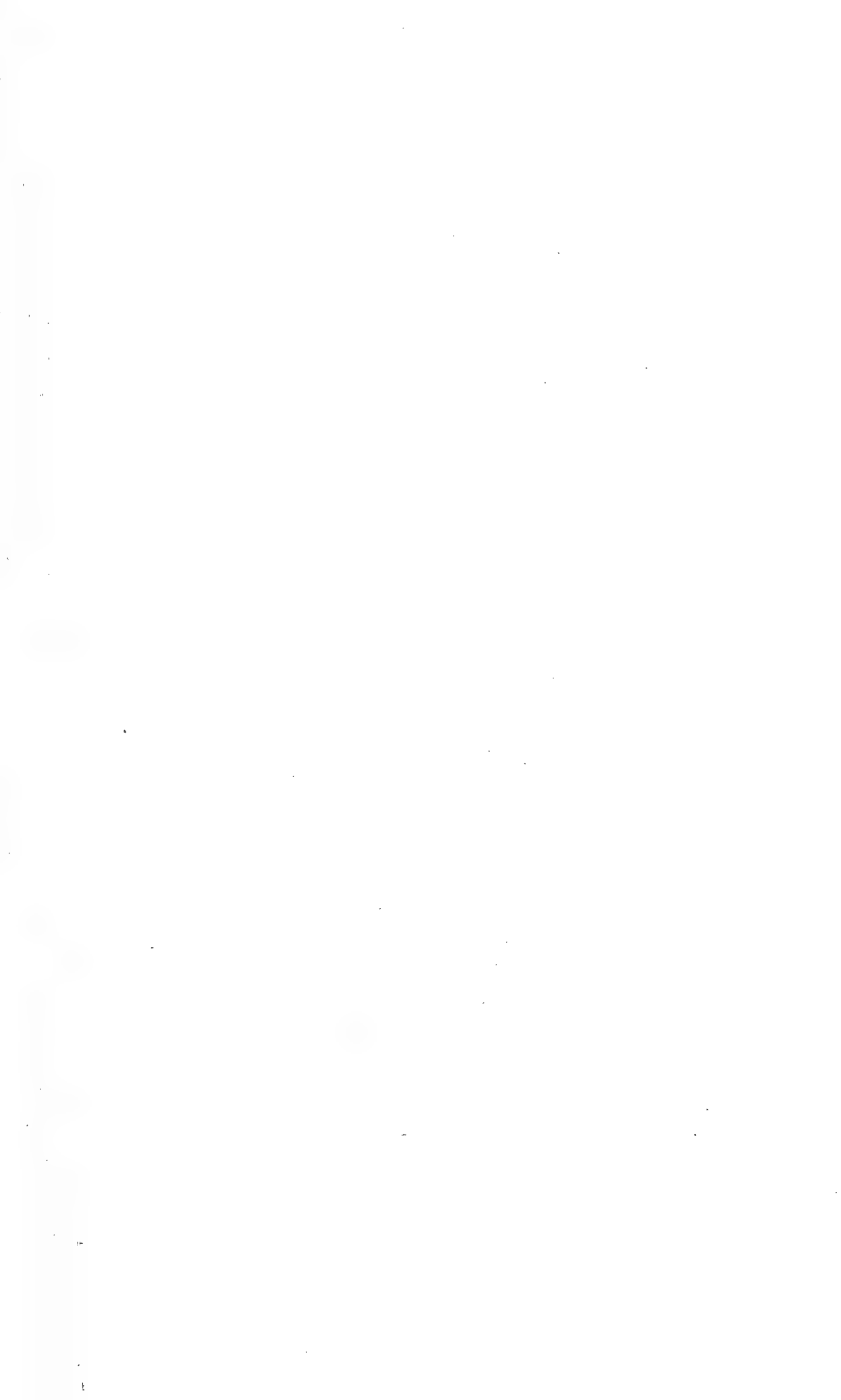

could be made out in the drift of this area. Prof. Hughes's Clwydian or St. Asaph Drift must certainly be considered the newest, as it is mainly remanié. It is situated at a low level between the important rivers Elwy and Clwyd. The high-level drift at Cae Gwyn is a true undisturbed glacial deposit full of ice-scratched boulders, and may be correlated with the deposits mentioned by Mr. Strahan, in his Geological Survey Memoir, as occurring at so many points at a high level in this area. The palæontological evidence shows that the caverns contained a large proportion of the animals found in the Norfolk Forest-bed, which Prof. Hughes admits to be preglacial. The absence of other forms would only show that they had probably not migrated into this area, hence this cannot be relied upon as evidence of difference in age.

Dr. Hicks was perfectly convinced by the evidence found during the explorations that the caverns of Ffynnon Beuno and Cae Gwyn (the other caverns referred to by Prof. Hughes are nearer the great rivers and at a much lower level, therefore the evidence obtained from them is of much less value) must have been occupied by man and the animals before the climax of the ice age. Also that the thick stalagmite was formed during the ice age, that this was broken up by marine action during the submergence, and that the caverns were afterwards completely covered over by materials deposited from floating ice. The mammalian remains and the implements, he therefore maintained, must be considered as of preglacial age.

Dr. J. EVANS spoke on the difficulty of reconciling the views of the two geologists who had spoken; perhaps both were right in part. He pointed out that a valley must have been cut when the upper end of the Cae Gwyn cavern was opened. In a case in Norfolk of supposed preglacial implements, the Boulder-clay beneath which they were found proved to be a remanié deposit.

If the cave were preglacial, either the glacial age in Wales was distinct from that in the east of England, or Man went away and returned again. The implement from Cae Gwyn resembles those of the upper deposits of Kent's Cavern. Now some of the implements in the east of England are made of stones brought into the district by ice of the glacial period. We have also evidence that Plas Newydd cave is postglacial. It is improbable that similar implements are preglacial in Wales and postglacial in the south of England.

Prof. BOYD DAWKINS said that he had examined much of the drifts of Wales and Lancashire, and doubted if those of the Vale of Clwyd could be distinguished from each other as clearly as Prof. Hughes contended. The interest attaching to the cave depends on the light which it throws on the relation of Palæolithic man to the Glacial period. After examining the fresh section he felt obliged to accept Dr. Hicks's evidence. The drift above the place where the implement was found was, in his opinion, not *remanié*, but *in situ*. The fact that Palæolithic implements occurred in Postglacial

deposits in other caves in the neighbourhood did not prove that they are of Postglacial age in this cavern, because there is evidence at Crayford, in Kent, that the river-drift man was Preglacial in the valley of the Thames. Palæolithic implements are found over a wide area in the Old World—in the south of Europe and north of Africa, in Egypt, Palestine, and in India; and their distribution can only be accounted for by the river-drift man having lived for a long series of ages on the earth, long enough, indeed, to be pre- as well as postglacial.

With regard to the Mammalia found in the caves of the Vale of Clwyd, nearly all were living in the eastern counties in the preglacial age. There is clear proof (1) that the Pleistocene Mammalia invaded Europe in the preglacial age; (2) that they were driven away from the British area by the results of the lowering of the temperature and of the depression of the land; and (3) that they returned and occupied the British area after the retreat of the ice and the re-elevation of the land. They therefore afford no evidence as to the relation of the deposit in which they are found to the Glacial period.

Mr. DREW asked Dr. Hicks at what depth (behind the fence) did the solid rock occur beneath the place where there was now material tipped by the workmen.

Dr. HICKS, in reply to Mr. Drew, said that the shaft exposing the drift-section was at the furthest end of the cavern from the old fence.

Prof. CARVILL LEWIS regretted not having seen the cave itself, though he had examined the glacial deposits of the neighbourhood and of North Wales generally. He was glad to hear that the views of the speakers this evening were in favour of a simplification of glacial phenomena. From a study of glacial deposits in many parts of Great Britain and Ireland, he had been led to believe that there had been only one advance of the ice and one retreat, one slight elevation and one slight submergence, and that the submergence in the non-glaciated area was contemporaneous with the maximum extension of the ice in the glaciated area. There were three main areas of local glacial dispersion in Wales, the glaciers from each of these being defined by terminal moraines. But there was also satisfactory evidence that an ice-lobe coming from Scotland and filling the Irish Sea had impinged upon the extreme northern border of Wales, and passing over Anglesey and along the west side of the Snowdonian mountains on the one side, and into Cheshire and along the east of the mountains on the other side, had pushed its terminal moraine against the highlands and in the teeth of the opposing local glaciers. The latter were both earlier and later than the northern ice-lobe, and the two drifts were therefore often commingled. The line dividing the northern ice-lobe from the Snowdonian glaciers was close to the cave under discussion, and the massive deposits near St. Asaph were probably washed out of the common terminal moraine. The undoubted marine deposits, full of

shells, which cover the lowlands of Lancashire up to 150 feet above the sea, also extended up the Vale of Clwyd to the same level; but much of the stratified material in this valley was remanié. Torrential freshwater action operating during the melting of the ice is an important factor not to be omitted in studying valley-gravel. Many terrace-deposits supposed to be marine are of freshwater origin and of late glacial age.

The PRESIDENT insisted on the importance of carefully weighing the evidence adduced by the Author, seeing to what an enormous extent it was proposed to carry back the date of Man's appearance on the earth. All those who had visited the open section seem to have regarded Dr. Hicks's views as, at all events, tenable.

Prof. HUGHES explained that the old hedge to which he referred was that shown in the sketch and photographs which he exhibited (it was about 16 feet from the opening in the drift above the upper entrance), and that no material from the cave had been thrown by the workmen over the part opposite the upper entrance. The scratched boulder produced, with the marks of agricultural implements, was one of many out of the drift dug from before the mouth of the cave, and was the one given him by Mr. Luxmoore as a typical specimen of the boulders in the drift. Pontnewydd and Plas Heaton caves could hardly be said by any one acquainted with the district to be at a low level near the great rivers. He would refer to his paper for the evidence in favour of his classification of the drifts, merely pointing out the difficulty of accepting Dr. Hicks's correction that the Arenig Drift is not necessarily the oldest, though he allows that the St. Asaph Drift must certainly be the newest.

He did not understand Prof. Dawkins's suggestion that Man could have lived through many glacial phases, if he was speaking of the district under consideration. When the Arenig ice covered everything, Man cannot have been there. He was not discussing the question whether Man may have been in existence anywhere on the earth while glacial conditions prevailed in Wales, but only whether there was evidence that the cave-deposits of the Vale of Clwyd were preglacial or a little later or much later. He had shown that, according to the best authorities, there was an earlier and a later Pleistocene group of mammals, and had pointed out that the animals in the Ffynnon Beuno caves belonged to the newer.

In reply to the President's remark, he regretted that Dr. Hicks should, after his attention had been more than once called to the inaccuracy of the statement, have again endeavoured to throw discredit upon his evidence on the ground that he had not had opportunities of examining the sections. Dr. Hicks had no means of knowing how often he had visited the locality, but had had the means of knowing from a printed report that he (Professor Hughes) had examined the caves, and proposed to explore them about a year before Dr. Hicks is supposed to have discovered them. Professor Hughes's home was close by; he had frequently visited the caves, and had on several occasions examined the drift that abutted against

the rock in the section referred to by Dr. Hicks from the bared limestone at the base to the surface. He could assure the President that he had not brought the matter before the Society without taking pains to make himself thoroughly acquainted with the facts of the case.

He was glad to have the concurrence of Prof. Carvill Lewis in the views he had put forward with regard to the sequence of events in Glacial times in Wales.

8. *On the DENTITION and AFFINITIES of the SELACHIAN GENUS PTYCHODUS, Agassiz.* By A. SMITH WOODWARD, Esq., F.G.S., of the British Museum (Natural History). (Read December 15, 1886.)

[PLATE X.]

NOTWITHSTANDING the abundance of the well-known teeth of *Ptychodus* in the Chalk of many localities, and the long list of specific forms that have already been recognized, very little information has hitherto been published in regard to the precise affinities of the fish to which they originally appertained. So rarely, indeed, are any of the teeth found associated in natural sequence, that it has been necessary to await the results of many years' patient collecting before being able to pronounce a decided opinion; but materials are now forthcoming for at least one further step in the determination of their relationships, and I therefore venture to offer to the Geological Society some account of the accumulated evidence.

Since these interesting fossils first became the subject of scientific study, it has been almost the universal custom, as is well known, to refer the genus to the somewhat comprehensive "family" of *Cestraciontidae*. An early determination of Mantell*, it is true, resulted in the suggestion that they formed the dental armature of fishes allied to the Teleostean Diodons; but the elaborate researches of Agassiz†, supported by Owen's simultaneous investigation of their microscopical structure‡, have always been cited as ample proof of the affinity of their original possessor with the *Cestracion* Sharks; and the deeply rooted tendency among palæontologists to refer every isolated crushing-tooth to the same extraordinary group has also contributed to the adoption of this arrangement without serious question.

But the original observations from which the inferences as to the systematic position of *Ptychodus* were deduced are obviously of a very uncertain and inconclusive character. In the absence of any but scattered remains Agassiz was compelled to make use of suggestive appearances and probabilities rather than well-ascertained facts; and in framing his conclusions he particularly emphasized at least two of these leading points. In the first place, certain groups of teeth seemed to be so arranged that the smaller and more prehensile examples occupied an anterior position, while the more truly grinding-teeth were scattered posteriorly, thus indicating a disposition analogous to that of the living *Cestracion*; while, secondly, there were good reasons for suspecting that a number of

* G. A. Mantell, 'Fossils of the South Downs,' 1822, p. 231.

† L. Agassiz, 'Recherches sur les Poissons Fossiles,' vol. iii. pp. 56-59, 150-158, 162.

‡ R. Owen, "On the Structure of Teeth," Brit. Assoc. Rep. 1838, Trans. Sect. p. 140; and 'Odontography,' pp. 57-59, pls. xviii., xix.

curious "Ichthyodorulites" also armed the dorsal fins of the same fish.

Owen's further evidence in a similar direction consisted in the remarkable resemblance between the medullary tubes traversing the dentine of the teeth and those to be observed in the teeth of *Cestracion* and *Acrodus*; and in this particular it became obvious that there was a marked divergence from the dentinal structure of *Rhynchobatus* (*Rhina*)*, with which the peculiarities of mere external form suggested comparison.

The latter superficial resemblance has frequently been noted by subsequent writers †, and Dixon has even remarked ‡ upon the possibility of the genus *Rhynchobatus* affording some clue to the arrangement of the fossil teeth in the jaws. But until eleven years ago the three fundamental arguments of Agassiz and Owen remained unshaken, and it is only within this later period that comparatively satisfactory materials for study have been forthcoming. Professor E. D. Cope was the first, in 1875 §, to show that the supposed dorsal spines of *Ptychodus* were really the paired fins of Teleostean fishes, having discovered much more complete specimens in the Cretaceous beds of the Western Territory of Kansas. And last year, in the pages of 'Science Gossip' ||, I was able to demonstrate briefly that the fossils upon which Agassiz based his conclusions as to the arrangement of the dental armature were likewise misleading, and that there was not the slightest agreement with the Cestraciont plan.

As regards microscopical structure, it seems possible to draw conclusions from Owen's observed facts somewhat different from the original inferences still generally accepted. And it is with a discussion of the two latter questions, especially the first named, that the present communication is particularly concerned.

In the prosecution of such an inquiry the fossils in the National Collection afford several important fragments of evidence, and of these it is proposed to offer some detailed descriptions. But the most beautiful and instructive specimen that I have the honour of bringing before the notice of the Society forms one of the fine series of Cretaceous fossils in the Brighton Museum, collected by Henry Willett, Esq., F.G.S. To the latter gentleman I owe my best thanks for the opportunity of studying it in London and of utilizing it in the present investigation; and I have also to acknowledge much kind help from Edward Crane, Esq., F.G.S., Chairman of the Brighton Museum Committee, who first pointed out to me the fossil last spring.

* R. Owen, 'Odontography,' pp. 44-46, pl. xxiv.

† e. g. Pictet ('Paléontologie,' 2nd edit. 1854, vol. ii. p. 265) and Quenstedt ('Handb. der Petrefaktenkunde,' 1st edit. 1852, p. 181).

‡ F. Dixon, 'Geology and Fossils of Sussex,' 1850, p. 361; 2nd edit., 1878, p. 390.

§ E. D. Cope, "Vertebrata of the Cretaceous Formations of the West" (U. S. Geol. Surv. Terr., 1875), pp. 244 A-F.

|| Smith Woodward, "Chapters on Fossil Sharks and Rays.—IV.," 'Science Gossip,' vol. xxi. 1885, p. 109.

Descriptions of Specimens.

The detached teeth of *Ptychodus* are so familiar and have been so frequently figured, that nothing remains to be added to the published descriptions of their general form. But it will be convenient to anticipate slightly by referring to their original relations in the jaw. Each tooth was so placed that the large characteristic ridges and furrows had a transverse direction, while the borders parallel to these were completely anterior and posterior. Judging from the analogy of several recent Selachians to which the genus is most nearly allied, the somewhat excavated and abrupt boundary of the crown was posterior, while the more gently sloping and overhanging border formed the front; this is the interpretation adopted here, and in all our figures the anterior border is directed downwards.

On examining the associated groups of teeth, it at once becomes evident that they were arranged in the mouth on two distinct, but yet closely similar plans. The first type, of which I have already published a sufficiently accurate diagrammatic sketch (*loc. cit.*), is admirably elucidated by the fossils in the British Museum; and the second is equally well shown in Mr. Willett's specimen, which, moreover, demonstrates that the two arrangements were opposed to each other in the dentition of the same individual.

I. An interesting forerunner of the fossils revealing the first of these plans is a small example of *P. decurrens*, figured many years ago in Dixon's 'Geology of Sussex' (plate xxxii. fig. 5); but this is scarcely complete enough to give any satisfactory clue to the entire armature of which it formed a part. Only nine teeth are shown, though these indicate portions of no less than four parallel rows, one represented by three components, and the remainder exhibiting but two. There is evidence of one series composed of relatively large teeth, and the rows immediately adjoining this on either side are so completely alike in character and dimensions as to appear quite symmetrically disposed in regard to it; while a still more diminutive series alone remains to the left.

II. But the specimen of greatest interest in this respect still remains undescribed, and is shown of the natural size in Pl. X. fig. 1. Its precise locality is unknown, and there is some difficulty in its specific determination; but it is evidently a close ally of *P. decurrens*, even if not a variety of that form. Thirty-four teeth have been disengaged from the surrounding chalky matrix, and of these no less than twenty-three are shown in their natural order. There are remains of six parallel series, and the general appearance of the specimen is at once suggestive of symmetry about the row of largest teeth, which would thus be median when the dentition was complete. This series (0) is represented by five of its components, and it is noteworthy that there is scarcely any variation in size as they are followed from behind forwards; all, indeed, have approximately the breadth of 0.021 m., and the length of 0.016 m.* The series (1) immediately to the left of the median row is likewise

* All the measurements are given in decimal fractions of a metre.

represented by five teeth, but of its homologue to the right only four remain. These teeth also vary but little in size, and their average measurements are 0·013 in a transverse direction, and 0·01 antero-posteriorly. They are not adjusted to the edges of the interposed large teeth with any marked regularity, having no definite relation to the interspaces; but each example appears to be slightly adapted in shape to fit whatever position it occupies. A second lateral row (2), similarly adapted to the outer border of the first, is indicated by six of its components to the left and by two to the right; these are still smaller in size than the others, measuring only 0·01 by 0·009 on the left, though the two corresponding teeth situated more posteriorly on the right are a millimetre longer, and thus square. A still smaller and somewhat oblique series (3), forming a third lateral row, is represented to the right by a single tooth, the dimensions of which are only 0·008 by 0·008.

This specimen affords an excellent opportunity of observing the character of the surface-ornamentation of the teeth in different parts of the mouth, and entirely confirms the conclusions of Agassiz based upon scattered groups. There is no variation of importance, and such as would lead to the establishment of more than one species if the teeth were found detached; and, except in size, the lateral teeth only differ from the median in being slightly flatter, and, in a few cases, somewhat oblique.

III. Another fossil in the British Museum that may perhaps be referred to the same jaw as the preceding, though quite as probably belonging to the opposing dentition, is also of considerable importance, and is shown of the natural size in Pl. X. fig. 2. This is an undoubted example of *P. decurrens*, obtained from the Chalk of Dorking, and forms part of the late Dr. Bowerbank's collection (B. M., no. 39134). Twenty-one teeth are preserved in their natural relations, and these are the representatives of six parallel rows. The largest series, to the extreme right, is only indicated by a single one of its components; but of the second row there are three; of the third, six; of the fourth, six and the impression of a seventh; of the fifth, three; of the sixth, two; and on the back of the fossil there are several scattered examples of a seventh row (fig. 2, 7). In each of these rows there is exceedingly small variation in size, and the maximum transverse and longitudinal measurements are as follow:—

Series.	Transverse Measure.	Antero-posterior Measure.
1.	0·023	0·017
2.	0·015	0·012
3.	0·011	0·009
4.	0·009	0·007
5.	0·008	0·006
6.	0·006	0·005
7.	0·005	0·004

The teeth are slightly more displaced than in specimen No. II.; but the irregular manner in which the components of one series are

adapted to the next is again very evident, and there is the same slight accommodative variability in shape. The superficial ornamentation is also equally constant; but there is a greater tendency to obliquity in all the teeth, this becoming observable even in series no. 2, and especially marked in the rows beyond.

IV. A small example (fig. 3) of the same species from the Lower Chalk of Halling, Kent, affords the first definite indication of the second plan of arrangement already referred to. Only nine teeth are shown in their natural relative positions, forming parts of three parallel rows; but in the absence of further evidence, the remarkable want of symmetry is a most perplexing characteristic. The middle series, represented by four of its components, is considerably the largest; but in the two adjacent rows the teeth of the one side are notably smaller than those of the other, as shown by the following average dimensions:—

Series.	Transverse Measure.	Antero-posterior Measure.
0.	0·006	0·005
1.	0·014	0·010
2.	0·010	0·007

It is also noteworthy that in the smallest teeth the peculiarities of the grinding-surface are somewhat abnormal, the peripheral granulated area encroaching to such an extent upon the transversely furrowed portion that the latter becomes quite inconspicuous.

V. But a complete explanation of this specimen is afforded by Mr. Willett's magnificent fossil from the Chalk of Brighton (Pl. X. figs. 4–10). Like most of the other comparatively undisturbed remains, it is referable to the common *P. decurrens*, and no less than thirty-four teeth are firmly cemented together in their natural relations by slightly crystalline pyrites; while seventy others were originally associated with this mass, though now detached in small groups and isolated specimens.

Of the jaw already described, only seven teeth are cemented in the main mass, and these belong to the median and the first left lateral row; but of the opposing jaw, hitherto entirely unknown, there are satisfactory remains of six longitudinal series, and certain detached fragments afford evidence of still more. Here, again, there is complete symmetry around a median azygous row; and in describing the arrangement it will obviously be necessary to use the terms right and left in the opposite sense to that already employed in reference to fig. 1.

The median series is scarcely visible on the grinding-surface, only a portion of one tooth projecting through the hard pyrites; but evidence of its presence is afforded by the distinct abrasion of the summits of the opposing teeth, and one of its components is exposed on the back of the fossil, while two others are shown in a detached fragment. These teeth (fig. 5) are comparatively small, elongated antero-posteriorly, and, like those of the most diminutive row in specimen No. IV., are somewhat abnormal from the circumstance that the granulated ornament considerably encroaches upon the

median area usually occupied by transverse ridges and furrows. Each tooth is narrowed in front, the blunt anterior end fitting into the slightly forked and broadened posterior end of its predecessor, and the root is extraordinarily deep.

In the series (fig. 4, 1) immediately adjoining this median row on either side are arranged the largest teeth of the jaw, measuring as much as 0·025 in a transverse direction, by 0·019 antero-posteriorly. These (fig. 6) are quite of the normal type, rectangular, not much elevated, and approximately equal in size, so far as is indicated by the ten examples preserved.

The second lateral row (fig. 4, 2) is represented on the left by seven of its components, and on the right by four. These teeth only attain the average dimensions of 0·016 transversely, by 0·013 longitudinally, and there is little trace of obliquity; but a third and much smaller series, of which four teeth remain on the left (3), begin to exhibit a slightly rhomboidal form, and in their fossilized state are directed somewhat backwards. The latter have an average measurement of 0·012 by 0·01, and, like all the others of this jaw, do not exhibit any distinct traces of wearing.

The main mass does not afford evidence of further lateral rows, though some are evidently broken away from each side. But a detached fragment of the fossil (fig. 7) shows three examples of the right row no. 3, flanked outside with three members of a fourth series, which are again smaller and measure only 0·01 by 0·007. These teeth are very oblique, and seem to have been followed by at least one, and probably more outer rows, though no certain proof is forthcoming.

Of the opposing jaw, as already stated, only seven teeth are preserved in their original positions, five of these representing the median series, and the remaining two belonging to the first lateral row on the left. A detached median tooth (fig. 8) also seems to fit in a hollow in the main mass, and this, being divested of all adherent pyrites, may be described as a very typical example. It is rather larger than the largest in the other jaw (fig. 6), and more transversely elongated; and the crown of the tooth has a remarkably conical form, in consequence of the depth of the groove into which it is adapted to fit when biting. It measures 0·032 transversely, by 0·02 longitudinally, and the other corresponding teeth with worn summits are of approximately the same dimensions; but two associated examples, evidently just developed and never functional, are of somewhat greater size, having a breadth of 0·036 and a length of 0·023.

The grinding-surfaces of the two lateral teeth *in situ* are obscured by contact with the cementing pyritous matrix; but there are several loose specimens, and one is shown from two points of view in fig. 9. The dimensions are considerably reduced, averaging only 0·026 by 0·015; but there is the same transverse elongation, and the crown is likewise much elevated. It is also noteworthy that the examples showing most evident traces of wearing have a transverse measurement as much as four millimetres less than that of the newly

developed teeth of the same series, and there is a corresponding diminution in length.

Remains of a second lateral row are preserved in contact with a detached series of the left row no. 1 (fig. 10), and these are, again, smaller (measuring 0·016 by 0·012); but it is not possible to distinguish with certainty any of the teeth originally placed beyond.

Exactly as in the previous specimens—and as is to be observed in all associated groups of Ptychodont teeth—there is no remarkable variation in the ornament of the grinding-surface in different parts of the jaw (except in the small median row), and it is interesting to be able to determine that there is no difference in this respect between the upper teeth and the lower.

Mr. Willett's specimen also supports the conclusion, based upon the National fossils, that there is no regularity in the plan by which one row of teeth is adjusted to the next, and offers many good examples of the slight adaptive variability in shape. But there is one interesting fact in regard to this adaptation which is not so clearly demonstrated in the majority of specimens, and which is worthy of a passing note, since it affords a method of readily distinguishing "lefts" from "rights." The outer edge of every lateral tooth is more or less regular, being almost straight, and terminating anteriorly and posteriorly in a gentle rounded angle, while nearly all the modifications requisite to ensure the continuity of the dental armature are provided by the variable inner edge. In very many cases the posterior inner angle is produced considerably backwards (*e. g.* fig. 9); but neither this nor the other adaptations appear to affect the extent of the transversely ridged median area.

A further point of interest in the Brighton fossil consists in the well-marked character of the pressure-scars, produced—like those in the teeth of Proboscidian Mammals—by the forward progress of the dentition during growth. They occur as small polished patches, exposing in section the minute medullary canals with which the dentine beneath the surface is everywhere traversed; and, as might naturally be expected, they are most prominently shown in the older anterior teeth. Typical examples are shown in figs. 8, 9. Other teeth in the British Museum exhibit the same feature, though I am not aware of its having hitherto been noted, and scarcely any specimens show it so prominently as the example just described.

VI., VII. In the light of the foregoing facts, it will be interesting now to attempt a revision of the various specific types of the genus *Ptychodus*, and to endeavour to interpret the numerous associated groups of teeth that are already within the reach of scientific inquiry; but such will be a work of considerable extent, and it is beyond the scope of the present communication to enter this untouched field.

It may be worth while, however, to append sketches of the median teeth of two of the species, for comparison with those of *P. decurrens*; and the originals of figs. 11 and 12 are such teeth, belonging to *P. polygyrus* and *P. paucisulcatus* respectively. In the former (fig. 11) the ordinary median area is reduced to a small conical

eminence with radiating furrows; while in the latter (fig. 12) the same part of the grinding-surface is represented by about three very short, comparatively broad ridges, and the anterior granulated portion is marked by delicate branching grooves.

VIII. A concluding note may also be added upon a large median tooth of *P. decurrens* (fig. 13), which shows the extent to which abrasion sometimes proceeded before the final shedding. The scar caused by the opposing row of diminutive median teeth has assumed extraordinary proportions, and there are also three well-defined lateral marks of wearing. Two of the latter are observed on the left, and a larger one, connected with the median, is situated somewhat posteriorly to the right.

Conclusions.

On taking a general glance at the fossils just described, and considering their peculiarities as mutually illustrative, it seems possible at last to determine the precise character of the dentition of *Ptychodus*, at least so far as one species is concerned. The specimens numbered II. and V. (figs. 1 and 4) show distinctly the plan of arrangement of the two jaws, and the other small fossil No. III. (fig. 2) will obviously determine the number of parallel rows constituting the complete armature. Unfortunately, however, it is somewhat difficult to decide whether the latter specimen is truly referable to the jaw to which I supposed it to belong when my previously published diagram was sketched, or whether it rather appertains to the new type of dental arrangement revealed by Mr. Willett's fossil. It is undoubtedly an example of *P. decurrens*, and the rows marked 1 and 2 exhibit precisely the same relative proportions as those similarly denoted in specimen No. IV. (fig. 3); while there is no transverse elongation such as is evident in the most fragmentary jaw of No. V. (fig. 4). The larger tooth, on the other hand, does not agree very well either with the original of fig. 6 or that of fig. 8; but, on the whole, it seems most likely that the former is its homologue. Such being the case, there would be originally seven lateral rows on either side of the small median series, and the opposing jaw would almost certainly comprise an equal number. If, however, the large tooth in fig. 2 is one of a median row, there will only have been six lateral series in each.

Having determined so much, it requires but little study to demonstrate that the dentition is that of a true Ray, and does not bear the slightest resemblance to that of the Cestraciont Sharks. Though, at first sight, the specimen No. II. (fig. 1) might suggest its appertaining to a single ramus of the jaw—with the largest series in the middle, much as in the living *Cestracion*—yet the absence of all obliquity in the rows, and their completely symmetrical character, are features that at once forbid this interpretation; and Mr. Willett's specimen (No. V.) furnishes decided proof that such an idea is quite inadmissible. The two mandibular rami were thus placed almost in the same straight line, as is the case in so many of the living Rays,

and the symphysis (as usual in these fishes) produced no line of demarcation in the enveloping dental armature.

This approximate determination of the affinities of *Ptychodus*, indeed, seems to furnish a means of deciding upon the relative positions of the two jaws already described. For on examining recent Rays it will be observed that the contours of the dentition are nearly always slightly wavy, with a prominence at the symphysis of the lower jaw, and a corresponding groove in the upper; and this relation appears to be quite constant throughout the group.

There can be little doubt, therefore, that the lower jaw of the extinct genus under consideration was armed by the teeth so well displayed in the original of fig. 1, while the upper was provided with the series most satisfactorily shown in fig. 4.

But with regard to the *family* with which the Ptychodonts ought properly to be associated, the dentition alone is insufficient to afford a definite clue. For among recent Rays the characters of the teeth are never of more than generic value*; and there is so much variation among the members of the same group that it is impossible to proceed beyond a hazardous speculation. Even so peculiar a dental arrangement as that of *Myliobatis*, for example, does not prevail throughout the entire family to which it belongs, since one genus (*Dicerobatis*) appears totally different and is armed with ordinary diminutive teeth, while another (*Ceratoptera*) possesses no dentition whatever in the upper jaw, and has nothing of importance in the lower †. Owen and others, as already remarked, have frequently noted the superficial resemblance of *Ptychodus* to the living *Rhynchobatus*, and it is quite possible that there may be some natural affinity; but in this form the teeth are diamond-shaped, with the transverse ridges extending from corner to corner; and their quincuncial arrangement and microscopical structure are serious obstacles to a belief in the suggested relation just mentioned. The arrangement of the teeth in parallel rows, crossing the rami at right angles, and their gradual diminution in size from the median series outwards, are features perhaps indicating some affinity with the huge Myliobatidæ; and it is in proximity to these that I would venture to assign the genus a place. Unfortunately, however, the broken fragments of cartilage that constitute the only part of the skeleton hitherto discovered are not sufficiently perfect to yield any more definite information; and it is quite possible that we are here concerned with a representative of an extinct family as yet unknown to biological science.

And, in arriving at such a result, it is impossible to omit a passing allusion to Prof. Sir Richard Owen's supposed decisive argument in a different direction, derived from a study of microscopical structure. The distinguished author of the 'Odontography' himself has doubtless long ago abandoned the idea of being able to recognize fossil Cestraciant teeth from an examination of the pecu-

* A. Günther, 'Catalogue of Fishes in the British Museum,' vol. viii. pp. 434-498.

† A. Günther, *op. cit.* pp. 496-498.

liarities of the vascular dentine; and as such investigations failed to separate the Dipnoan *Ctenodus* and *Ceratodus*—and, still more, the Psammodonts and Petalodonts—from the Cestraciontidæ, it is not surprising that they were likewise unsuccessful in correctly determining *Ptychodus*. Microscopical structure, in fact, seems rather to depend upon function, and not so much on genetic relationship.

In conclusion, the question arises as to whence *Ptychodus* came, and whither its descendants, if any, departed. For, so far as is at present known, not a trace of this generic type occurs in any deposits beyond those of Cretaceous age; and no one has yet succeeded in discovering a Selachian tooth that is obviously a modification of the form so common in the Chalk. Mantell's *Ptychodus Mortoni*, it is true, is suggestive of an approximation to a more ordinary type of tooth, and it is not improbably one of the missing links required; and a Bohemian example, described by Reuss* as *P. triangularis*, is also worthy of special note for exactly the same reason. But the progress of palæontological knowledge is necessarily slow and uncertain, and we are compelled to remain satisfied with the present slight advance, while deferring the solution of these wider problems to a future occasion when still more materials may be available.

EXPLANATION OF PLATE X.

- Fig. 1. Portion of lower dentition of *Ptychodus*, sp. (B. M., no. 40056.)
 2. Portion of upper (?) dentition of *P. decurrens*. (B. M., no. 39134.)
 3. Portion of upper dentition of *P. decurrens*. (B. M., no. 38564.)
 4. Portion of upper and lower dentition of *P. decurrens*. (Collection of Henry Willett, Esq., F.G.S., Brighton Museum.)
 5. Tooth of upper median series, found associated with the preceding specimen.
 6. Tooth of upper series 1, associated with original of fig. 4.
 7. Teeth of right upper series 3, 4, associated with original of fig. 4.
 8. Tooth of lower median series, associated with original of fig. 4.
 9. Tooth of left lower series 1, associated with original of fig. 4.
 10. Teeth of left lower series 1, 2, associated with original of fig. 4.
 11. Tooth of upper median series of *P. polygyrus*. (B. M., no. p 319.)
 12. Tooth of upper median series of *P. paucisulcatus*. (B. M., no. 4358.)
 13. Much-worn tooth of lower median series of *P. decurrens*. (B. M. no. 33247.)

B. M. = British Museum. All the specimens are from the Chalk of Kent and Sussex, and are drawn of the natural size, with the anterior border in each case directed downwards.

DISCUSSION.

The PRESIDENT congratulated the British Museum on obtaining the assistance of so promising a young palæontologist as the author of the present paper.

Prof. SEELEY expressed a high opinion of the paper. The subject was one of much difficulty, as was shown by its having baffled a

* A. E. Reuss, 'Die Versteinerungen der böhmischen Kreideformation,' pt. i. (1845) p. 2, pl. ii. figs. 14-19. This species was subsequently referred to *Acrodus* by A. Fritsch, 'Reptilien und Fische der böhmischen Kreideformation,' 1878, p. 16 fig. 38.

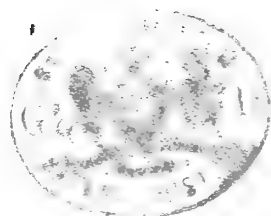

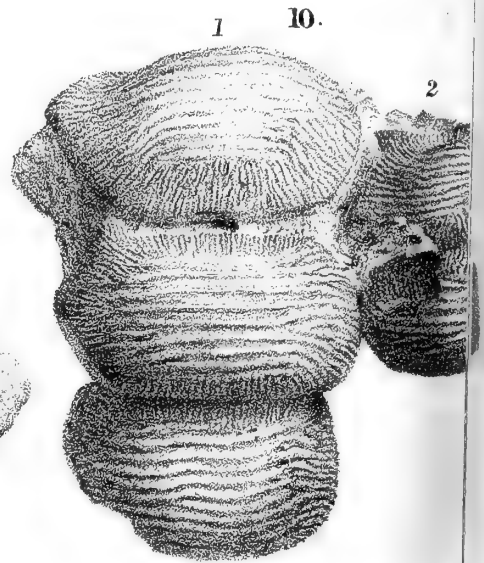
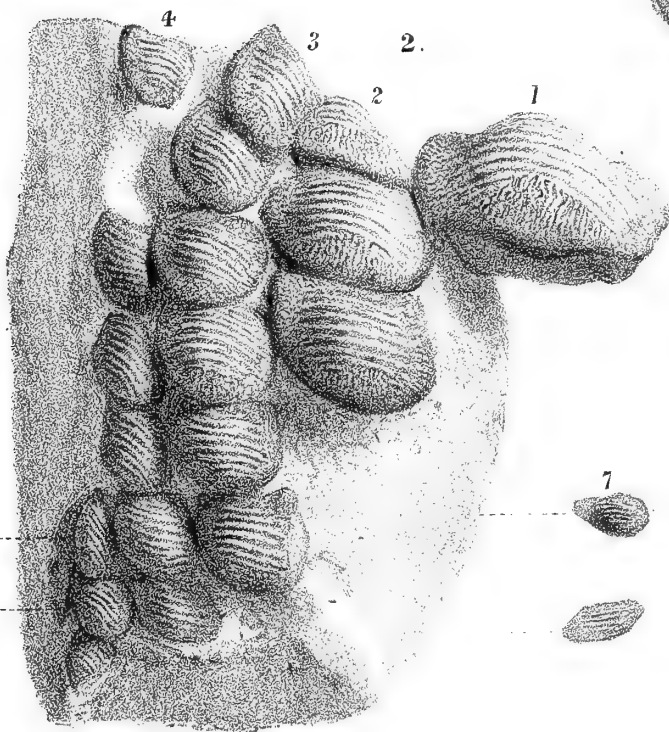
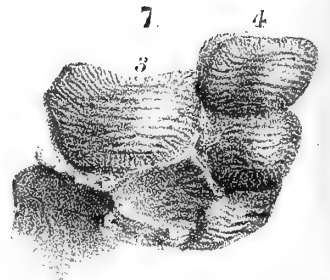
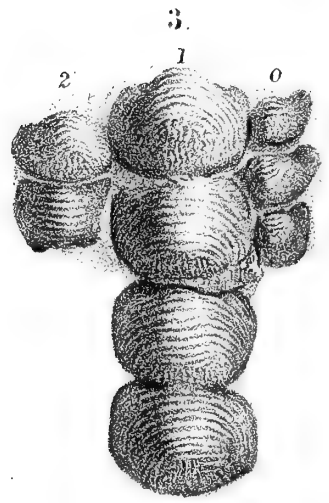
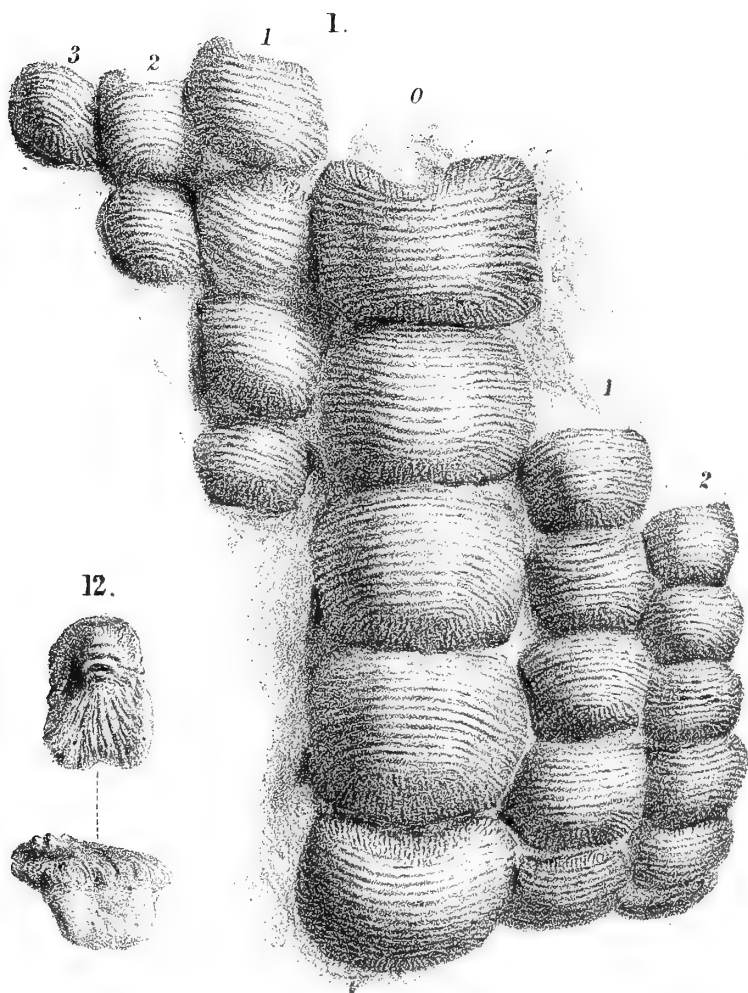

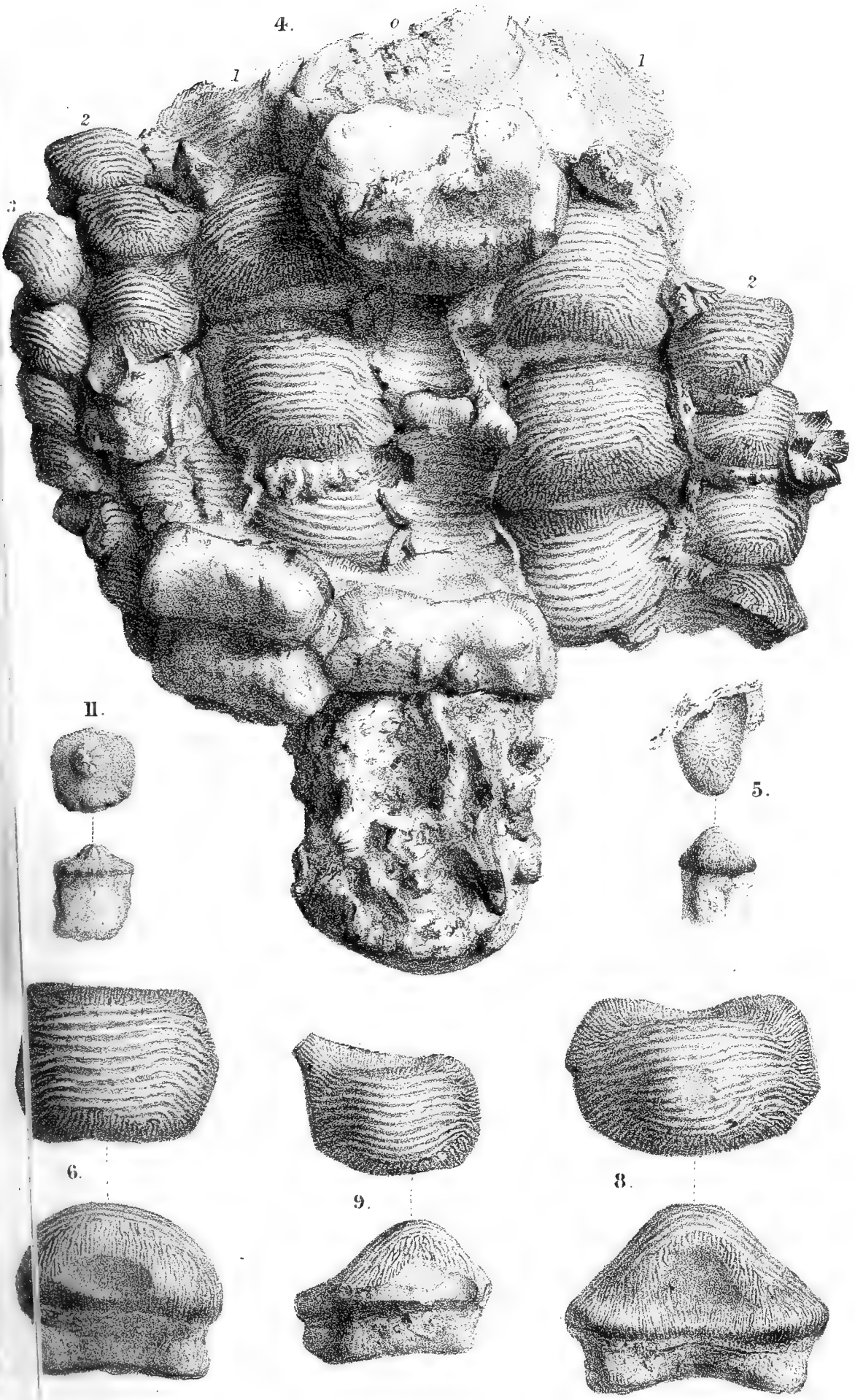



naturalist of so much knowledge as Agassiz. There was a fine series of specimens of *Ptychodus* in the Woodwardian Museum at Cambridge; but although these showed the linear and parallel arrangement of the teeth and apposition of the jaws, and although the method of wearing resembled that of the Rays, the subject had not been dealt with by any one so clearly as the examples in the Brighton and British Museums had been worked out by Mr. Woodward. At the same time Prof. Seeley thought there was still some question if *Ptychodus* was really a Skate. It was certainly the type of a peculiar plagiostomous family.

Mr. NEWTON pointed out that if the arrangement suggested by Mr. Smith Woodward was correct, the large teeth of the lower jaw ought to be worn on both sides, and those of the upper jaw on the inner side.

Mr. LYDEKKER said he had described a dental plate of a *Myliobatis* from the Eocene of India which appeared to show an approximation in its contour to *Ptychodus*.

Dr. H. WOODWARD had not seen the Cambridge specimens, but noticed the very fine example from Brighton; the specimen now exhibited showed portions of the teeth of both jaws well preserved. He pointed out the absence of the Cestraciont prehensile teeth, and their replacement by crushing-teeth in *Ptychodus*. This was a most important observation of Mr. Smith Woodward's. He thought the present discussion would throw some light on the peculiar crushing-teeth of Carboniferous Sharks.

The AUTHOR, in reply, said that in the paper he had treated the question of attrition. The lower median teeth were worn not only on each side, but also on the summit. The evidence at present seemed to him to leave it doubtful whether *Ptychodus* was the type of a new family or not. He agreed with Dr. Woodward that forms like *Psammodus* would have some light thrown on them by investigations into the dental arrangement of *Ptychodus*.

9. NOTE on NUMMULITES ELEGANS, *Sowerby*, and other ENGLISH NUMMULITES. By Prof. T. RUPERT JONES, F.R.S., F.G.S. (Read December 15, 1886.)

[PLATE XI.]

THERE being much confusion in the supposed relationship and published synonymy of *Nummulites elegans* (*Nummularia**, Sowerby), I propose to offer some remarks on the history of this species, more especially as less trouble would have been caused if I had taken more care years ago, and examined all, instead of only some, of Mr. Sowerby's specimens which have been associated with that name.

Having just now seen (October 1886), for the first time, the "Sowerby Collection" at the British Museum (Natural History, Cromwell Road), I find that Sowerby's labelled specimens of "*Nummularia elegans*" are really the same as my variety *Prestwichiana*† of *Nummulites planulatus*, which the late Dr. Philippe De la Harpe regarded as a variety of *N. wemmelensis*‡. Other specimens, however, which belong to true *N. planulatus*, were confused by Sowerby with his *N. elegans*.

Specimens labelled "*Nummularia elegans*" on the original card, No. 44007 (1) in the "Sowerby Collection," are exactly such as come from the well-known bed "no. 29" (at the base of the Barton Clay) of Prof. Prestwich's section of the strata at Alum Bay, Isle of Wight, in the Quart. Journ. Geol. Soc. vol. ii. (1846), p. 257, pl. 9. fig. 1. One horizontal section among them matches one of Sowerby's drawings in the 'Mineral Conchology,' pl. 538, namely the 10th figure on the plate (counted in the order of the figs. 1, 2, 3), included in "fig. 2," and probably magnified two diameters. The other drawings in "fig. 2" do not match the specimens from the bed "no. 29," but those referred to in the text (p. 76, vol. vi.) as having come from "Emsworth," and which are still in the Collection, and are so marked. These so-called "Emsworth" specimens evidently belong to *N. planulatus*, such as is found on the Continent, as indicated by me in the Quart. Journ. Geol. Soc. vol. viii. (1852) p. 350, note.

In 1852, Mr. James De Carle Sowerby, at my request, showed me the "Emsworth" (*N. planulatus*) specimens at his own house; but, not comparing the figures and text of the 'Min. Conch.' at the same time, and not seeing the others (that is, the real "*N. elegans*" of the Collection), we did not discriminate the two sets of specimens; and my note (Q. J. G. S. 1862, p. 92), written on the occasion, refers only

* The generic term *Nummularia* used by Sowerby is an unnecessary synonym of *Nummulites*, Lamarck; and the reasons for preferring *Nummulites* to *Nummulina* are given in full in my 'Catalogue of the Fossil Foraminifera in the British Museum,' 1882, pp. 90, 91.

† Quart. Journ. Geol. Soc. vol. xviii. (1862), p. 93.

‡ Catal. Foss. Foram. Brit. Mus. 1882, pp. 22 & 92.

to the *N. planulatus* (allocated to *Emsworth*) alluded to in the text of the 'Mineral Conchology' at page 76, vol. vi.

No locality is given for Sowerby's real *N. elegans* (pl. 538, part of fig. 2), though its identity with specimens from Bed "no. 29" cannot be doubted; and the mention of "Emsworth" is made incidentally for the other Nummulite, about the relationship of which Sowerby may well have been uncertain.

In the British Museum ("Sowerby Collection") we find No. 44007 (1) labelled "*Nummularia elegans*, W. D. S." There are several specimens mounted on a card. One is illustrated by the 10th figure (part of "fig. 2") on pl. 538, Min. Conch. vol. vi. (September, 1826*), and described at p. 76, under *Nummularia elegans*.

No. 44007 (2) is the same, together with fragmentary shells, in a clay with glauconite and coarse quartz grains, much rounded. This is evidently the glauconitic clay-bed of the Barton series, part of "no. 29" of Prestwich's Section at Alum Bay, Isle of Wight, Q. J. G. S. vol. ii. (1846) p. 257, pl. 9. fig. 1.

As Sowerby's "*elegans*" is definitely the same as *Nummulites Prestwichianus* (var. of *planulatus*), Jones, of the bed "no. 29," and as Dr. Ph. de la Harpe determined some of these Barton ("no. 29") Nummulites sent to him to be a variety of *N. wemmelensis*, we have three names for this little fossil. If it be a species of itself, the name *elegans* would have priority of any other, unless the commingling of the two forms in the 'Mineral Conchology' *loc. cit.* interferes with the value of the evidence of the original card with mounted specimens, labelled "*N. elegans*" by Sowerby. It is unfortunate that Mr. Sowerby at the same time referred some specimens of another species (previously described by Lamarck as "*Lenticulites planulata*") to his *N. elegans*, figuring them with it, and alluding to some of their features in his account of *N. elegans*. Nevertheless it is easily distinguished both among his figures and among his specimens preserved in the British Museum. Accepting "*elegans*" as subordinate to Vanden Broeck and De la Harpe's *N. wemmelensis*, we must replace the varietal name of *Prestwichiana* by that of *elegans*. Doubtless, in a zoological point of view, *wemmelensis* is itself a variety of *planulatus*; and this latter, as De la Harpe puts it, is a subordinate member of the *N. Murchisoni* group, or, as Prof. W. K. Parker and myself have regarded it, a variety of *N. perforatus* lower than *complanatus* and its allies †. Therefore *elegans* (*Prestwichianus*) is a variety of *planulatus* in our sense; but it is not advisable to ignore the specific value of *wemmelensis*, on which Dr. De la Harpe has bestowed much careful research; and *N. wemmelensis*, De la Harpe, var. *elegans*, Sow., is a correct denomination for the Nummulite under notice.

To proceed:—

In the "Sowerby Collection":—No. 44007 (3) contains the individuals shown by the 9th and 11th figures (part of "fig. 2") on pl. 538. No. 44007 (4) has the 6th figure (part of "fig. 2") on

* For the exact dates of the parts and volumes of this work, see Professor E. Renevier's note in the 'Bullet. Soc. Vaudoise Sci. Nat.' 2 Mai, 1855.

† See Ann. & Mag. Nat. Hist. ser. 3, vol. viii. pp. 233, 234.

pl. 538. No. 44007 (5) has the 7th and 8th figures (part of "fig. 2") on pl. 538. These are said to be from Emsworth, near Chichester, and consist of a siliceous shell-rock not otherwise known in England. These specimens, Nos. 44007 (3, 4, 5), were those which I saw with Mr. Sowerby in 1852, and understood to be *N. elegans*. Recognizing them as *N. planulatus*, and probably foreign, and, not seeing the others, I did not adopt the name *elegans*, but designated the Barton specimens of bed "no. 29," in which I was then interested, by a new name.

It will be well to mention that in plate 538 of the 'Min. Conch.' the *Nummulites lævigatus* is illustrated by "fig. 1" at the top; *N. variolarius* by "fig. 3," in the middle; and *N. elegans* [and *N. planulatus*] by "fig. 2," at the bottom. Counting the figures individually, for convenience of detailed reference (as De la Harpe does), "fig. 1" comprises nos. 1-5, "fig. 2" nos. 6-11, and "fig. 3" nos. 12-17, counting in the order of figs. 1, 2, and 3; if in the order of actual position on the plate, the sequence would be different. Of "fig. 2," at the bottom, no. 10 is the real "*elegans*"*, the others being *N. planulatus* at different stages of growth†, and from 3 to 10 millim. in diameter.

Elucidative Scheme of Plate 538 'Mineral Conchology.'

Fig. 1.

1.	2.	3.	4.	5.	}	<i>N. lævigatus</i> (nat. size).

Fig. 3.

12.	13.	14.	15.	16.	}	<i>N. variolarius</i> (nat. size and magnified).

Fig. 2.

6.	7.	8.	9.	10.	11.
Adult.	Young.		Vertical section.	Horizontal section.	Adult.
<i>N. planulatus</i> (nat. size).			<i>N. elegans</i> (enlarged).	<i>N. planulatus</i> (nat. size).	

* This horizontal section, differing from any such on the "Emsworth" stone (on which, indeed, there are only one or two exposed), is like those of the specimens from bed "No. 29;" and if magnified twice, as is probable, would be about $2\frac{1}{2}$ mm. in diameter.

† Such, for instance, as may be observed among a set of specimens of this species from Forêts, near Brussels, and elsewhere.

It may also be remarked that the labelled card, No. 44008 (1), with *Nummulites variolarius* (Lamarck), contains the specimens figs. 12th, 14th, and 17th (part of "fig. 3") of pl. 538. No. 44008 (2) is *N. variolarius*. No. 44008 (3), *N. variolarius*, contains the 13th, 15th, and 16th figures (part of "fig. 3") of pl. 538. No. 44008 (4), *N. variolarius*, without a locality, is a calcareous lump of these little fossils, certainly from France, like the coarser of the two specimens from Betz, Dep. Oise, "P. 969," in the British Museum; 'Catal. Foss. Foram. B. M.' 1882, p. 38.

1826. The description of *N. elegans* by James De Carle Sowerby, in the 'Mineral Conchology,' vol. vi. p. 76, is as follows:—

"NUMMULARIA ELEGANS, Tab. DXXXVIII. fig. 2.

"Spec. Char. Compressed, smooth; whorls about six; septa gently curved from the axis, numerous [alar prolongations of the chambers]; aperture rather prominent.

"This differs from the last [*N. levigatus*] in being smaller, in having fewer whorls, which increase more rapidly, and in the regular curvature of the septa. When young, it is very smooth and regularly lenticular. The large figure [*N. planulatus*] shows several series of diminishing chambers, as mentioned in the observations upon the genus [pp. 73–74].

"A siliceous stone occurs at Emsworth, near Chichester, that contains among other shells an abundance of these Nummulites [*N. planulatus*] filled also with silex, the other shells are too imperfect to ascertain in our specimens.

"It is an intermediate species between *Lenticulina* and Nummulites of Lamarck."

In this description some features of *N. planulatus* are confused with those of *elegans* itself.

The Emsworth stone referred to consists of siliceous internal casts of Mollusks (Bivalves and Gasteropods) and Nummulites, with siliceous cement. This last was sandy, and contains some glauconitic grains.

Inquiring of Prof. Prestwich in 1882, about this "Emsworth" stone, I was favoured with a letter in which he informs me that he has "searched in vain for the section with *Nummulites* at Emsworth, and that it may have been in a small temporary pit in a lane. The place itself is on the [lower] London Clay." ('Catal. Foss. Foram. Brit. Mus.' 1882, p. 24.)

"The village stands in greater part on Chalk and Gravel; but on the outskirts southward it passes on to the Lower Tertiaries, and possibly to the Bognor Beds" (Prof. Prestwich, November 10, 1886). A well, therefore, may reach some Lower Tertiary beds; but no siliceous fossils are known in them.

Prof. Prestwich, however, has suggested to the author that, as very little is known of the "Bognor Rock," and nothing of its lower portion, it is just possible it may possess some peculiar stratum holding *N. planulatus*; and that this would be such as on the Continent occupies the horizon equivalent to that of the London Clay, including the Bognor Rock.

In the 'Proceed. Geol. Assoc.' vol. ii. (1872) p. 158, Mr. Caleb Evans referred to this Nummulite, described by Sowerby and found at "Emsworth Common," as possibly indicating the presence of the "Bracklesham Series" at that place, about 3 miles to the east of Portsdown Hill.

Mr. Clement Reid, F.G.S., who is also well acquainted with the country near Chichester and Havant, writes me (Oct. 23, 1886), in reply to inquiries:—"I have referred to all the maps, but cannot make out how any Nummulite rock can occur *in situ* at Emsworth. It may, however, be possible that Sowerby is right; for having worked within two miles of Emsworth, I find that as the Chichester synclinal is a good deal sharper than on our old Geological Survey map, Bracklesham beds may occur near Emsworth. There is another possible explanation, namely, that Sowerby's specimen was from an erratic block. There are several blocks of Bognor Rock scattered over the country."

Mr. Keeping, in a letter dated November 25, 1886, says—"The strata at Emsworth are London Clay and Woolwich beds; so we may be certain that the occurrence of the Nummulite is a mistake."

In the British Museum, the late Mr. F. E. Edwards's collection contains several loose specimens of both *N. Prestwichianus* and *N. variolarius*, labelled as having come from "Emsworth;" but this is *exceedingly doubtful*, for they and the small Mollusks and other fossils with some of them have every appearance of specimens from Barton and Highcliff.

1837. H. Galeotti, in his "Mémoire sur la constitution géognostique de la Province de Brabant" (Mém. couron. Acad. R. Belg. vol. xii. 1837, p. 141), quotes "*Nummulina elegans*, nobis et Sowerby, Min. Conch. pl. 538. fig. 2," as occurring at Forêts, Jette, and Laeken, in Belgium, and at Barton!

1846. In Prof. Prestwich's memoir "On the Tertiary Formations of the Isle of Wight," in the Quart. Journ. Geol. Soc. vol. ii. at page 254, bed no. 16 at Whitecliff Bay is said to contain "*Nummulites elegans*" (the Rev. G. Fisher regards this as probably being *N. variolarius*, Q. J. G. S. vol. xviii. p. 70; and it is near the position of Mr. Keeping's *Prestwichianus*-bed, see p. 145); beds nos. 14-12 to contain *N. lævigatus*; and bed no. 11 to contain *N. elegans* and *scaber* (referable to *N. variolarius* and *N. lævigatus*). At page 257 the bed "no. 29" at Alum Bay is said to have *N. lævigatus* and *N. elegans*. Here the latter agrees with Sowerby's determination (see above); whilst the former species may occur lower down in the Bracklesham portion of the bed "no. 29," but it is doubtful*. Mr. Keeping states that *N. variolarius* (or a thick *Prestwichianus*) is met with in Mr. Prestwich's "no. 29," in the upper portion of the *brown* part, and the flattened form midway between this and the base of that clay (Letter, November 25 & 29, 1886).

1848. In Bronn's 'Lethæa geognost., Index palæontolog.' vol. i.

* I did not note this species in Mr. Prestwich's collection from Alum Bay in 1852 (see page 147).

p. 628, Sowerby's *N. elegans* is referred to "*Lenticulites planulata*," Lamarck, with doubt.

1850. Dixon's 'Geology of Sussex,' &c. 1st edition.

P. 85. *Nummularia variolaria*, Sow. Min. Conch. t. 538. f. 3, Stubbington; common.

P. 85. *N. elegans*, Sow. M. C. t. 538. fig. 2, Alum Bay, Isle of Wight; rare.

P. 85. *N. radiata* (Montfort), Bracklesham; rare: pl. ix. fig. 7; this is *N. variolaria* with some of its septal lines raised externally.

Mr. Sowerby himself drew up this list, and applied the name "*elegans*" to the specimens from Alum Bay then under notice, having already given that name to the same species from the same place in 1826, though unfortunately mingled with others (*N. planulatus*) in the description and figures.

1850. In his 'Histoire des Progrès de la Géologie,' vol. iii. (1850), p. 236, M. d'Archiac states that, in Sowerby's pl. 538. fig. 2, "les figures de droite, de gauche et la coupe du milieu," named "*elegans*," may be "*N. planulata*"; and at p. 240, that in fig. 2 "les trois plus petites seulement" are "*N. planulata*." These three smallest figures, however, really comprise two of *planulatus* and one of *elegans*.

1852. In the Quart. Journ. Geol. Soc. vol. viii., at p. 350, Sir Charles Lyell added this note to his Memoir on the Belgian Tertiary Formations:—

"Mr. T. Rupert Jones informs me that the Nummulite figured as *N. elegans* in the 'Mineral Conchology' from specimens marked 'Emsworth, near Chichester,' and which Mr. J. de C. Sowerby has kindly permitted him to examine*, is (as suggested by M. d'Archiac, Hist. Progr. Géol. vol. iii.) undoubtedly the *N. planulatus* of continental geologists. It is probable, therefore, that in that part of England where the Bracklesham beds with *N. lævigatus* are so largely developed, strata characterized by *N. planulatus* also exist; and it is highly desirable that their relative position should be carefully studied."

The succession (downwards) of the Nummulites in Belgium is stated in Sir C. Lyell's paper, *op. cit.* pp. 279 and 349, to be:—

Sables moyens, ou Grès de Beauchamp.	} = Upper part of the Calcaire grossier.	} <i>N. variolarius</i> . Laekian. Barton Clay.
Calcaire grossier.		
Sables infé- rieurs, Sables Soissonais, partie supé- rieure.	} <i>N. planulatus</i> .	} { Paniselian? and Up- per Ypre- sian. } [Not in Eng- land †.]

1854. D'Archiac and J. Haime, in their 'Monogr Nummulites,' &c. (1853-54), p. 143, refer to Sowerby's *N. elegans*, 'Min. Conch.' vol. vi. (1829), p. 76, pl. 538. fig. 2, as *N. planulata*, var. *α*, pl. ix.

* Had the Alum-Bay specimens, also labelled "*N. elegans*," been examined at the same time, this name would have been retained for them.

† Unless in an unknown stratum of the "Bognor Rock" (see p. 135)

figs. 10, 10 *a-c*. At p. 146 they properly refer to Sowerby's fig. 3 as *N. variolaria*, and figure it in pl. ix. fig. 13.

1854. In Morris's Catal. Brit. Foss. 2nd edit. p. 38, *N. elegans*, Sow., is placed under *Nummulites planulatus*, Lam.

1862. The Rev. O. Fisher, in his Memoir "On the Bracklesham Beds," Quart. Journ. Geol. Soc. vol. xviii., allocates *Nummulites variolarius*, *laevigatus*, and *Prestwichianus* to their several beds of the Bracklesham and Barton formations, at pages 67, 70-84, and says (p. 84):—"At Alum Bay the greater part of the fossiliferous beds included in No. 29 of Mr. Prestwich's Section (Quart. Journ. Geol. Soc. vol. ii. pl. 9) may be correlated satisfactorily with those usually known as the Barton and Highcliff series. There is a well-known and marked seam of dark green sandy clay, containing abundance of *Nummulina Prestwichiana*. It contains Barton forms; and therefore we may safely carry the Barton series down so far, though it is lower in series than any bed from which fossils have hitherto been collected at Highcliff. The same Nummulite-bed occurs there also" (see p. 87).

1862. At Whitecliff Bay part of the 'No. 17' of Prof. Prestwich's section, Quart. Journ. Geol. Soc. vol. ii. p. 254, and of the xix. of Mr. O. Fisher's section, Q. J. G. S. vol. xviii. pp. 69 & 70, is regarded by Mr. Fisher as the equivalent of the green bands which form the base of the Barton beds at Highcliff and Alum Bay, and these contain the *Nummulina planulatus* [*wemmelensis*], var. *Prestwichiana*.

1862. Quart. Journ. Geol. Soc. vol. xviii. pp. 93, 94. Appendix B to the Rev. O. Fisher's memoir "On the Bracklesham Beds."

"Note on NUMMULINA PLANULATA, Lamarck, sp., var. PRESTWICHIANA, Jones. By T. Rupert Jones, F.G.S.

"This little Nummulite is discoidal, smooth, and flat, rarely in any degree biconvex, even in the young state, unless the outer whorl has been flattened by pressure; about $\frac{1}{10}$ th inch in diameter, and $\frac{1}{7\frac{1}{2}}$ th in thickness. The gently sigmoid and semitranslucent edges of the septa appear at the surface, and but seldom rise above it (except when the specimens are mechanically compressed, which is a common condition). The whorls (three [four] in large specimens) are all visible in empty shells made transparent by water or Canada-balsam; they are proportionally wide for *Nummulina* (the outer whorl making half [$\frac{3}{8}$ th or $\frac{2}{5}$ th] the width of the disk). The chambers are about half as long as wide, neatly curved, but subject to irregularity of growth. The lateral portions of the chambers, though very shallow, are continued over the surface towards the centre on each face, and are rather straighter in old specimens than in the young [?].

"This neat and delicate variety of *Nummulina planulata*, Lamarck, sp., has long been known in a clay containing much green sand, at Alum Bay, Isle of Wight (lower part of the bed 'No. 29' of Mr. Prestwich's Section, Quart. Journ. Geol. Soc. vol. ii. p. 257, pl. 9. fig. 1); but it has not hitherto been described*. It is near to MM.

* The writer did not then know that Mr. J. De C. Sowerby had included this Nummulite under the description of *N. elegans* in the Min. Conch. vol. vi. p. 76.

d'Archiac and Haime's *Nummulites planulata*, var. *a*, from Jette Belgium; but the latter has a biconvex centre (opaque when mounted in balsam), has narrower whorls (in the proportion of 1 to 4, instead of $1\frac{1}{2}$ to 4), and grows to a somewhat larger size. To distinguish our variety (which characterizes a well-marked geological zone), I propose to give it the name of *Prestwichiana*; and, as the small biconvex variety of *N. planulata* passes binomially as *N. variolaria*, so this small depressed variety of the same species may be allowed to stand on a similar footing, and be known as *N. Prestwichiana*.

"In the sandy clay-bed at Alum Bay the shells of this little Nummulite are very numerous, and often well preserved, but not unfrequently much crushed by pressure. In many specimens, especially large ones, the chambers are occupied by iron-pyrites; and neat casts may be obtained by carefully dissolving the shell in weak dilute acid. In the clay at High Cliff the shells are not so numerous, are very much compressed, and so highly pyritized that they are readily destroyed by the atmosphere."

It may be added that even in the smaller specimens the alar chambers though "radiate" are not straight, but curved; and in the largest individuals they become "sinuate"; therefore this form is one of the "sinuo-radiates" *.

1863. In a letter dated November 9, 1863, the Rev. O. Fisher wrote:—

"This *N. Prestwichiana* seems to range over what I have taken as the junction of the Bracklesham and Bartons. At Alum Bay the forms with which it occurs are Barton forms, while at Hunting Bridge it lies at the bottom of a thick bed of Bracklesham fossils." He also refers to *N. variolaria*, a species of the Barton series, as occurring at King's-Garden Gutter, New Forest ("Brook," F. Edwards), "rare, but persistent."

1876. Ann. & Mag. Nat. Hist. ser. 4, vol. xvii. p. 286. Among some fossil Nummulites dredged up in the English Channel, *N. Prestwichiana* was met with, and it is noted that this last form was described in the Quart. Journ. Geol. Soc. vol. xviii. pp. 93, 94, as *N. planulata*, var. *Prestwichiana*, and possibly may be essentially the same as *N. planulata*, var. *α. minor*, d'A. & H., which occurs at Jette, in Belgium."

1878. Dixon's 'Geology of Sussex,' &c., 2nd edition by T. R. Jones.

Page 172. *Nummulina variolaria* (Lamarck). Strongly ribbed; pl. ix. (10), fig. 7.

Page 172, note by T. R. J.:—

"*Nummulina elegans*, Sow. 'Min. Conch.' t. 538, referred to at p. 85 in the First Edition, was [in part] originally described from a specimen said to have come from a well † at Emsworth, near Portsmouth. It is not known anywhere else in England. The figured specimen [11th figure in fig. 2 of the plate] closely resembles speci-

* Ann. & Mag. N. H. ser. 3, vol. v. p. 109, vol. viii. p. 115.

† I do not know where I learnt this fact; perhaps Mr. Sowerby gave me the information.

mens from Belgium. *N. Prestwichiana* (Quart. Journ. Geol. Soc. vol. xviii. p. 93), from the junction-beds of the Bracklesham and Barton series at Alum Bay, may have been mistaken for [on the contrary, was correctly given by Mr. Sowerby as] *N. elegans* in the catalogue at p. 85 of the First Edition."

1879. Writing (October 1, 1879) about some English Nummulites which I had sent to him, Dr. Philippe De la Harpe explained his views about *Nummulites wemmelensis*, and the variety *Prestwichiana*, which latter I now refer to Sowerby's *elegans*; and he stated that of *N. wemmelensis* (which, though rare, occurs at Brussels, Jette, Wemmel, Laeken, Ghent, and Briendereck in Belgium) he recognized the following varieties:—

1. Type: size 2–3 millim.; shape irregularly lenticular, with knob in the centre; surface smooth. Wemmel and Jette.
2. Var. *plicata*: size $1\frac{1}{2}$ –2 millim.; shape lenticular, with depression in the centre; surface plicated. Ghent.
3. Var. *granulata*: size $1\frac{1}{2}$ –2 millim.; shape flat, surface granulated. Brussels, Park St. Gilles.
4. Var. *minor*: size 1 millim.; lenticular, smooth, regular.
5. Var. *Prestwichiana* [= *elegans*]: size 1–2 millim.; flat, smooth, regular.

The spire is very nearly the same in all the varieties; the last is always much larger than the foregoing whorl. By its variations this species has affinities with *N. variolarius*, with *Assilina*, and with *Operculina* *.

In the 'Catal. Foss. Foram. Brit. Mus.' 1882, pp. 91–93, I stated that "the proposed specific name '*N. wemmelensis*' for the type to which my '*N. planulata*, var. *Prestwichiana*' evidently belongs, had such strong justification, that I acceded to the acceptance of my friend Ernest Vanden Broeck's suggestion. Still, for convenience, the term '*Prestwichiana*' has been frequently entered in the Catalogue, as a synonym." It seems now that *elegans* has priority, if not over *wemmelensis*, yet over *Prestwichiana* as one of its varieties.

This *Prestwichiana* or *elegans* is one of the Nummulites which have a large primordial or central chamber, *N. wemmelensis* also having the character typically.

In Belgium the late De la Harpe found eight species, consisting of four pairs of Nummulites, one of each pair having a very small, and the other a large central chamber, thus:—

Small central chamber.	Large central chamber.
1. <i>N. planulatus</i> , Lamarek	{ <i>N. elegans</i> , De la H. (nos. 9 and 11 of Sowerby's fig. 2. pl. 538). <i>N. planulatus</i> , D'Archiac.
2. <i>N. laevigatus</i> , Lam. (Type and varieties <i>scaber</i> , <i>rotula</i> , <i>globularius</i>).	} <i>N. Lamarcki</i> , d'Arch.
3. <i>N. Heberti</i> , d'Arch.	} <i>N. variolarius</i> , Lam.
4. <i>N. Orbigny</i> (<i>Operculina</i> , Galeotti).	} <i>N. wemmelensis</i> , Vanden Broeck (= <i>N. planulatus</i> , var. <i>a</i> , vel <i>minor</i>).

* See De la Harpe's letter in the 'Catal. Foss. Foram. Brit. Mus.' p. 92.

Among Nummulites in general, the same pairing of species holds good, thus :—

Central chamber	
Small.	Large.
N. perforatus.	N. Lucasanus.
N. Brongniarti.	N. Molli.
N. complanatus.	N. Tchihatcheffi.
N. gizensis.	N. curvispira.
N. contortus.	N. striatus.
N. biaritzensis.	N. Guettardi.
Assilina exponens.	Assilina mamillata.
A. spira.	A. subspira.

See Catal. Foss. Foram. Brit. Mus. pp. 92, 93.

The constant association, in the same strata, of large individuals with a small, and small individuals with a large central chamber, is more fully treated in Dr. Ph. De la Harpe's "Mém. on the Nummulites of Switzerland" (Mém. Soc. Pal. Suisse, vol. vii. 1881), at p. 63, &c., thus carrying out to a practical result the observations made by Prof. Parker and myself in the 'Annals Nat. Hist.' ser. 3, vol. vii. 1861, p. 233. Dr. De la Harpe, however, appears not to have seen this paper, nor our "Notes on Nummulites," *op. cit.* vol. v. 1860, pp. 109, 294, &c.; nor Carpenter, Parker, and Jones's observations in the 'Introd. Study Foram.' Ray Soc. 1862, pp. 262–276; at least he does not refer to them in detail.

1881. "Etude des Nummulites de la Suisse," &c., première partie, Mém. Soc. Paléontol. Suisse, vol. vii. At page 29, referring to some forms which he thought that D'Archiac had confused under the name of *planulata*, Dr. De la Harpe stated that the little form, with large central chamber, figured by Sowerby as *N. elegans*, 'Min. Conch.' pl. 538. figs. 6–11 [Sowerby's "fig. 2"], and taken by D'Archiac for young *N. planulatus*, should retain the name given by Sowerby.

I consider the nos. 6–9 and 11 (in "fig. 2") to be really *N. planulatus* of different stages of growth; but, coming under that genus instituted by Lamarck, they did not require a new name; whilst "no. 10" is one of the specimens on Sowerby's card labelled "*Nummularia elegans*," and forming the chief subject of his paragraph on *N. elegans*, *op. cit.* p. 76.

Dr. De la Harpe having found some small lenticular *planulati* with a large central chamber, regards them as one of his *twin species*. Nos. 7 and 8 in Sowerby's "fig. 2" are like these externally, and may or may not have the large central chamber. At all events they either are or have been mixed up, in the siliceous rock of "Emsworth," with *planulatus* (nos. 6–9, and 11). Even if they be the same as De la Harpe's twin species referred to (Numm. Suisse, pl. 7. figs. 12–23), they cannot be called *elegans*, as that name is on Sowerby's label of the *Prestwichiana* variety from Alum Bay.

1883. In the posthumous portion of our deceased friend Dr. Phil. De la Harpe's "Etude des Nummulites de la Suisse et Révision des Espèces Eocènes des Genres Nummulites et Assilines," partie troisième (Mém. Soc. Paléontol. Suisse, vol. x.), 1883, p. 169, we have the synonymy of the little Nummulite under notice thus given:—

NUMMULITES WEMMELENSIS, De la Harpe and Vanden Broeck, pl. xi. figs. 52–70. (Var. *Prestwichii*, figs. 65–70.)

1822. *Nummulites lenticula* (pars), DeFrance, Dict. Sc. Nat. vol. xxxv. p. 226.

1837 (?). *Id.* (pars), Galeotti, Mém. constit. géogn. Brabant; Mém. Acad. Belg. vol. xii.

1837. *N. elegans* (pars), Galeotti, *op. cit.*

1853. *N. planulata*, d'Orb. var. *a. minor*, D'Arch. et Haime, Monogr. Numm. p. 143, pl. 9. f. 10, *a, b, c.*

1861. *Id.* Lam. sp., var. *Prestwichiana*, R. Jones, Quart. Journ. Geol. Soc. vol. xviii. p. 93.

At p. 171, De la Harpe, under "*Nummulites planulata*, Lamarck sp." (pl. vii. figs. 1–11), places:—

"1829. *Nummularia elegans* (pars), Sowerby, Mineral Conchology, vol. vi. p. 76, pl. 548. figs. 6, 7, 8 (*non* figs. 9, 10, 11)."

Excepting no. 10, these (Sowerby's "fig. 2") are in my opinion definitely *N. planulatus* (Lam.).

At p. 175, under "*Nummulites elegans*, Sowerby" (pl. vii. 12–23), De la Harpe places:—

"1829. *Nummularia elegans* (pars), Sow. Min. Conch. vol. vi. p. 76, pl. 538. figs. 9, 10, 11 (*non* 6, 7, 8)." These also, excepting no. 10, are *N. planulatus*; De la Harpe's figures 12–20 are like young *planulatus* with large central chamber, and externally like some (nos. 7 and 8 of Sowerby's "fig. 2") which accompany other *planulati* of larger growth. His figs. 21–23 represent a very thin form ("*depressa*").

The English Nummulites.

I. NUMMULITES ELEGANS, Sowerby. Pl. XI. figs. 1–9.

The following synonymy of *N. elegans*, Sowerby, is here offered as being in accordance with what we have noted above:—

1826. *Nummularia elegans* (part.), Sowerby, Min. Conch. vol. vi. p. 76, pl. 538. fig. 2 (part, namely, no. 10).

1837. *Nummulina elegans* (part.), nobis et Sowerby, Galeotti, Mém. constit. Géogn. Brabant, p. 141.

1846. *Nummulina elegans*, Prestwich *, Quart. Journ. Geol. Soc. vol. ii. p. 257.

1848. *Lenticulites planulata* (?), Bronn, Index Palæont. vol. i. p. 628.

* At p. 254 *N. variolarius* appears to have been misnamed *elegans*.

1850. *Nummularia elegans*, Sowerby in Dixon's Geol. Sussex, p. 85.

1850. *Nummulites planulata* (part.), D'Archiac, Hist. Progrès Géol. vol. iii. pp. 236 and 240.

1853. *Nummulites planulatus* (part.), Jones, Quart. Journ. Geol. Soc. vol. viii. p. 350, note.

1854. *Nummulina planulata*, var. *a*, vel *minor* (part.), D'Arch. & Haime, Monogr. Num. p. 143.

1854. *Nummulites planulatus* (part.), Morris, Cat. Brit. Foss. 2nd edit. p. 38.

1862. *Nummulina planulata*, var. *Prestwichiana*, Jones, Quart. Journ. Geol. Soc. vol. xviii. p. 93.

1878. *Nummulina planulata*, var. *Prestwichiana*, Jones in Dixon's Geol. Sussex, 2nd edit. p. 172, note.

1881. *Nummulites elegans* (part.), De la Harpe, Numm. Suisse, part i. p. 29.

1882. *Nummulites Wemmellensis*, var. *Prestwichii*, De la Harpe, Catal. Foss. Foram. Brit. Mus. pp. 92, 93.

1883. *Nummulites Wemmellensis*, var. *Prestwichiana*, De la Harpe, Numm. Suisse, part iii. p. 169.

1886. Max von Hantken in the Földtani Közlöny, xvi. Kötet, 1886, in a paper on some American Nummulites (p. 188), pl. 1. fig. 4, gives "*N. elegans*" after De la Harpe, Etude Numm. Suisse, p. 175, pl. 7. f. 12-23, with 5 whorls, not rapidly increasing.

In addition to the general description of *N. elegans* (*Prestwichiana*) given above at page 138, the following notes on its size and proportions will be useful in its identification. (Mr. C. D. Sherborn has kindly given me his help in measuring the small English Nummulites.)

Sowerby's figure* no. 10 in "fig. 2," magnified probably two diameters, represents a specimen about $2\frac{1}{2}$ millim. across, with 4 whorls, there being the following number of chambers in the whorls:—

1st.	2nd.	3rd.	4th.
7	14	22	35?

Sowerby's specimens (from the bed "no. 29," Alum Bay), flattened by pressure, are of various sizes, as usual; and one, broken open (not artificially bisected*) and not well preserved, gives:—

* Sowerby's mounted specimens of "*N. elegans*" from Alum Bay do not offer any good horizontal sections. Those that have their median chambers exposed have been broken open, in breaking the matrix, with such an uneven fracture that they do not show sections of an even plane like that seen in specimens carefully ground down, and hence they have the central chambers obscure.

	Measurements in millimetres.		Number of whorls.	Number of chambers in the whorls.			
	Diameter.	Thickness.		1st.	2nd.	3rd.	4th.
One of Sowerby's specimens	$1\frac{3}{4}$	$\frac{1}{2}?$	4	9?	13	14?	20?
Specimens from Alum Bay (bed "no. 29") flattened by pressure.	$1\frac{1}{4}$		4	7	14	21	26?
	$1\frac{1}{2}$	$\frac{1}{4}$					
	$1\frac{3}{4}$	$\frac{1}{4}$					
	$2\frac{1}{4}$						
	2	$\frac{1}{3}$					
	$2\frac{1}{2}$	$\frac{1}{3}$					
From Whitecliff Bay (Keeping's <i>Prestwichianus</i> -bed). Nearly all the specimens are flattened by pressure.....	$3\frac{1}{2}$	$\frac{1}{3}$	4	8	14	20	?
	ordinary	...					
	ordinary	$\frac{1}{2}$					
	3	$\frac{1}{2}$					
From Highcliff ("D," Keeping), not flattened by pressure	$4\frac{1}{2}$ *	$\frac{1}{2}$	4?	8	13	?	?
		$\frac{1}{2}$	4?				
		$\frac{1}{2}$	4?				
	$\frac{3}{4}$	$\frac{1}{4}$	4	8	14	19	?
	$1\frac{1}{4}$	$\frac{1}{2}$					
2	$\frac{1}{2}$						
$2\frac{1}{4}$							
$1\frac{1}{2}$	$\frac{1}{3}$						
From Hunting Bridge, New Forest	$1\frac{3}{4}$	$\frac{1}{3}$	4	8	12	18	25?
	$1\frac{3}{4}$?†					
	$1\frac{1}{4}$?					
	?	?					
	?	?					
	?	?					
	$\frac{1}{2}$	4	8	15	20	?	
	$\frac{1}{2}$	4?	8	15	?	?	
	$\frac{1}{2}$	4?	8	14	?	?	
	2						
	$2\frac{1}{4}$	$\frac{1}{2}$					

In Bed "no. 29" the specimens are thin and compressed, with the alar prolongations ("alæ," or lateral extensions) of the chambers nearly all reaching the centre, somewhat curved; more sinuous and less regular in old individuals (Pl. XI. fig. 1). From the Hunting-Bridge beds specimens given to me by the Rev. O. Fisher, F.G.S., are only slightly flattened; their alæ reach the centre. Mr. Keeping's specimens "B," from Hunting Bridge, are not flattened; their alæ generally, but not in every case, reach the centre. Those from Highcliff (Keeping, "D") are not flattened; their alæ reach the centre. Some individuals of *elegans* have partially radiate or plicate surfaces, due to the lessening of the septal ribs and a local convexity of the alar parts of the chambers, probably the var. *plicata*, De la Harpe (see above, p. 140).

For the localities of Sowerby's *N. elegans* (or *Prestwichiana*) we find in the 'Cat. Foss. Foram. Brit. Mus.' 1882, pp. 22-25 (besides the Bed "no. 29" at Alum Bay) Bracklesham, F. Edwards; biconvex variety, Bracklesham, F. Edwards; Barton, F. Edwards; Barton, with *N. variolarius*, F. Edwards; Emsworth, with *N. variolarius*,

* In the Museum of Practical Geology, Jermyn Street. See Pl. XI. fig. 1.

† These were ground down without their thickness having been measured. They probably ranged about $\frac{1}{2}$ millim.

F. Edwards; and Emsworth, with *Turbinolia*, F. Edwards. Of these some, if not all, may have been wrongly localized (see above, page 136). Further, from Bramshaw, Brook, and Highcliff; the last is thickish and associated with *N. variolarius*; all from the late Mr. Fred. Edwards's Collection. Some rare, dredged off Guernsey, as noted in the Ann. & Mag. N. H. April 1876, p. 283. We have received from the Rev. O. Fisher and Mr. Keeping some from Hunting Bridge and from Highcliff, also some in a glauconitic clay from Whitecliff Bay, found by Mr. Keeping in a zone just below "no. 17" of Mr. Prestwich's Section*, and 13 inches thick. This is regarded as equal to a part of "no. 29," Alum Bay. The specimens are both large and small, compressed, and not pyritous. I may mention that not only did Prof. Prestwich give me characteristic specimens of the *Prestwichianus* and *variolarius* from their several beds in or about 1852, but I took a note of the occurrence of these and other Nummulites as then preserved in his Collection.

II. NUMMULITES VARIOLARIUS (Lamarck). Pl. XI. figs. 10-14.

1804. *Lenticulites variolaria*, Lamarck, Annales du Muséum, vol. v. p. 187, no. 2.

1826. *Nummularia variolaria*, Sowerby, Min. Conch. vol. vi. p. 76, pl. 538. figs. 3 (nos. 12-17).

1854. *Nummulites variolaria*, D'Archiac et Haime, Monogr. Numm. p. 146, pl. 9. fig. 13.

Nummulina et *Nummulites variolaria*, auctorum †.

Small, smooth, lenticular, with a rather sharp edge; the alar extensions are numerous (18-20 visible), distinct, long-triangular, nearly all reaching the umbo on the convex faces of the shell; the median chambers are usually about as high as long; central chamber rather large; the whorls four, regular, increasing slowly. Occasionally the septal lines become thickened and raised, chiefly by a lessening of the shell-matter along the alar intervals; and a radiately-ribbed appearance is thus given to the shell. A swollen condition of the alar extensions also, in some cases, gives a similar appearance. See 'Min. Conch.' pl. 538. fig. 3 (no. 16); and Dixon's 'Geol. Sussex,' pl. 9. fig. 7.

The alar parts of the chambers, in passing to the umbo, often vary from their usual straight line to a gently curved, and even falcate form, thus passing from the "radiate" to the "sinuo-radiate" type of Nummulite. They rarely interfere one with another. The umbo is always conspicuous, and sometimes flattened. The alar septa are often strong, but not so thick as in the young *N. planulatus*. The latter, moreover, soon loses its convexity between the umbo and margin; in its young state it is "radiate," and in the adult condition fully "sinuo-radiate." See Ann. & Mag. N. H. ser. 3, vol. viii. pp. 233, 234.

* See above, page 138. "No. 16" contains *N. variolarius* as a characteristic fossil.

† Some remarks by Dr. Ph. De la Harpe on this species are given in the 'Bull. Soc. Géol. France,' sér. 3, vol. v. pp. 826, 827 (1879).

The dimensions of *N. variolarius* are:—

	Measurements in millimetres.		Number of whorls.	Number of chambers in the whorls.				
	Diameter.	Thickness.		1st.	2nd.	3rd.	4th.	5th.
Sowerby's figure (no. 14, in "fig. 3")	2							
Stubbington*	$1\frac{3}{4}$	$\frac{1}{4}$	4	?	11?	17	23	
Whitecliff Bay, bed no. 16 of Prestwich's section †.....	$1\frac{1}{2}$	$\frac{1}{2}$	4?	7	10	14	?	
Whitecliff Bay, bed no. 11 of Prestwich's section	$1\frac{1}{4}$	$\frac{1}{2}$	4	?	13	15	20?	
King's-Garden Gutter ‡, New Forest (O. Fisher).	$1\frac{1}{2}$	$\frac{1}{2}$						
Three individuals of a large variety from the Barton Shell-bed	2	$\frac{1}{2}$	5	6	11	16	17	20

The three last have a large central chamber; one has straight, another oblique, and another curved alar divisions.

In the 'Catal. Foss. Foram. B. Mus.' 1882, this species is entered as occurring (p. 22) at Alum Bay, in the bed "no. 29" (on the authority of Mr. F. Edwards). At page 23-25 are the following:—

Bracklesham, Barton, and Stubbington, including large, ordinary, and small forms; Emsworth (F. Edwards), probably a wrong locality; Bramshaw, ordinary and large (F. Edwards); Highcliff, ordinary and large (F. Edwards). At p. 26, "a delicate variety like *N. venosa*," from Headon Hill (F. Edwards), is mentioned. Also Hunting Bridge and Shepherd's Gutter (Bramshaw), New Forest, O. Fisher, Quart. Journ. Geol. Soc. vol. xviii. pp. 79 and 81.

In the Quart. Journ. Geol. Soc. vol. xviii. 1862, the Rev. O. Fisher specially notes the occurrence of *N. variolarius* in the Bracklesham series at Whitecliff Bay, in his division xvii. (p. 70), part of Prestwich's "no. 16," Quart. Journ. Geol. Soc. vol. ii. p. 254; in xiv. (p. 71), part of Prestwich's "no. 14;" in ix. (p. 72), Prestwich's "no. 13." At Bracklesham Bay (p. 74) in the beds numbered 22 and 21 and 20. Also (pp. 77-83) at Stubbington, Hunting Bridge, Shepherd's Gutter, and King's-Garden Gutter.

According to Dr. De la Harpe the *N. variolarius* of the Barton beds of Stubbington and White-Cliff Bay is the same as that of

* Quart. Journ. Geol. Soc. vol. xviii. p. 78.

† Mr. Keeping also has contributed some from this zone of *N. variolarius*, which he finds to be 19 feet thick.

‡ This is the "Brook" locality of F. Edwards.

Belgium, and typical. He did not find *N. Heberti* (having a small central chamber) with it, though accompanying it in Belgium and France.

III. NUMMULITES LÆVIGATUS (Bruguière).

This species has been so well described by D'Archiac and other authors * that its structure need not be treated of here. It is well figured in the 'Min. Conch.' vol. vi. pl. 538. fig. 1.

The range of *Nummulites lævigatus* in England is limited. The Rev. O. Fisher has carefully defined its zones and localities, Quart. Journ. Geol. Soc. vol. xviii. In the Bracklesham series at *Whitecliff Bay* (p. 72) in the bed VII. (part of Prestwich's "no. 12"); in VI. (Prestwich's "no. 11"); in IV. (Prestwich's "no. 9"). At *Bracklesham Bay* (p. 75) in the beds 6 and 4; and at *Bury Cross*, near Gosport (Pilbrow). At *Alum Bay* its zone was indicated by Prof. Prestwich many years ago as a lower part of that thick bed, no. 29, which also comprises the glauconitic clay with *N. elegans*, Quart. Journ. Geol. Soc. vol. ii. p. 257; but this is very doubtful. *N. lævigatus* has also been found in the Wells at Wellington College and Woking Asylum.

According to Dr. Ph. De la Harpe the Bracklesham Nummulites comprise both *N. lævigatus* and *N. Lamarcki*, the latter having a large central chamber; and he thought that they indicate a horizon "at the top of the 'Paniselian' or at the bottom of the 'Bruxellian' Stage." Catal. Foss. Foram. Brit. Mus. p. 91.

A table of the range of Nummulites in England is given on the next page.

* Dr. Ph. De la Harpe ('Num. Suisse,' 1881, p. 29) has noticed that in his synonymy of this species in the 'Prodrome,' vol. ii. 1850, 25^e étage, 1302, D'Orbigny has by mistake given the name of *elegans* instead of *lævigatus* to fig. 1. pl. 538, 'Min. Conch.'

Table of the Range of *Nummulites* in England.

	<i>Numm. variolarius.</i>	<i>Numm. elegans (Prest- wichianus).</i>	<i>Numm. lævigatus.</i>	<i>Numm. planulatus</i> †
<i>Alum Bay</i>	In bed "no. 29" ? F. Edwards.	In part of Prest- wich's "no. 29" bed. O. Fisher's bed 10 (p. 84).	In part of Prest- wich's bed "no. 29"?	
<i>Whitecliff Bay</i> ...	In Prestwich's beds 16, 14, 13, 11 : xvii., xiv., ix. of O. Fisher's beds.	In bed just below Prestwich's 17 bed (Keeping) †.	In Prestwich's beds 12, 11, 9. In O. Fisher's beds vii., vi., iv.	
<i>Bracklesham Bay.</i>	In O. Fisher's beds 22, 20.	? (F. Edwards).	In O. Fisher's beds 6, 4.	
<i>Barton Cliff</i>	*	? (F. Edwards).		
<i>Highcliff</i>	*	* Fisher and Keeping.		
<i>Stubbington</i>	*			
<i>Hunting Bridge, New Forest.</i>	*	* Fisher and Keeping.		
<i>Shepherd's Gutter, or Bramshaw.</i>				
<i>King's-Garden Gutter, or Brook.</i>	*			
<i>Emsworth</i>	? (F. Edwards).	* Sowerby

EXPLANATION OF PLATE XI.

- Fig. 1. *Nummulites elegans*, Sowerby. The largest individual known.
× 10 diam. From Whitecliff Bay: collected by Mr. Keeping
(Geol. Mag. 1887, pp. 70-72). Museum of Practical Geology.
- | | | |
|---|---|------------------------------------|
| 2. The same. Ordinary example. × 10 diam. | } | From Bed no.
"29," Alum
Bay. |
| 3. The same. Vertical section. × 10 diam. | | |
| 4. The same. Horizontal section; from a transparent | | |
| individual in Canada balsam. × 20 diam. ; | | |

† In Prof. Prestwich's collection several years ago I noted among his specimens from Whitecliff Bay, in bed 16, *variolarius*; in bed 13 or 12, *lævigatus* and var. *scabra*; and in bed 11, *scabra* and *variolarius*. From Alum Bay only *N. elegans*, from "no. 29."

‡ A small derived or remanié specimen of *N. planulatus* (near *N. Boucheri*, De la H.) has been found in the Crag of Suffolk; see 'Foraminifera of the Crag,' part i. Pal. Soc. 1866, p. 74 &c., pl. 2. figs. 51, 52.

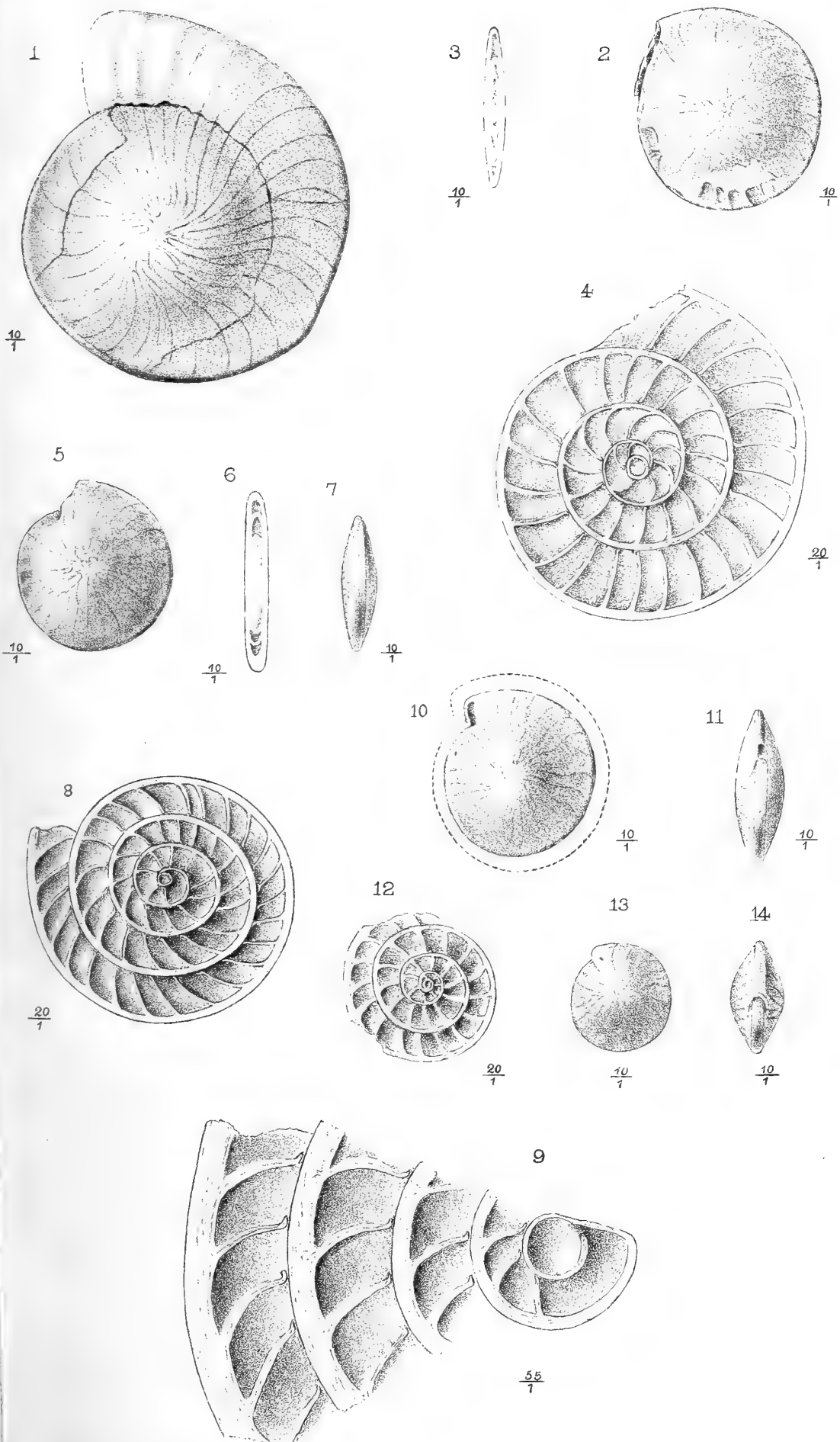

C. Sherborn del.

Geo. West & Sons. lith. et imp.

SOME ENGLISH NUMMULITES.



- Fig. 5. The same. Ordinary example. $\times 10$ diam.
6. The same. Vertical section of another individual. $\times 10$ diam.
7. The same. Edge view. $\times 10$ diam.
8. The same. Horizontal section. $\times 20$ diam.
9. The same. Part of horizontal section. $\times 55$ diam.
10. *Nummulites variolaris* (Lam.). Large individual. $\times 10$ diam. The dotted line around the figure indicates the size of a larger individual.
11. The same. Large individual. Edge view. $\times 10$ diam.
12. The same. Ordinary variety. Horizontal section. $\times 20$ diam. From Bed "No. 16" at Whitecliff Bay.
13. The same. Ordinary example. $\times 10$ diam.
14. The same. " " Edge view. $\times 10$ diam.
- } From Hunt-
ing Bridge,
New Forest.
- } From the Bar-
ton Shell-
bed.
- } From Bed "No. 11"
at Whitecliff Bay.

DISCUSSION.

The PRESIDENT said that the rectification of the name of an old species was of equal importance with the institution of a new form, and congratulated Prof. Rupert Jones on having cleared up an obscure question.

Dr. WOODWARD was glad that Prof. Rupert Jones had found some materials previously unrecorded in the Museum collections. The number of specimens exhibited at the new Museum was fortunately much larger than formerly in Bloomsbury.

Prof. SEELEY spoke of the importance of determining the forms of Nummulites, and gave a sketch of their distribution in the British Eocene rocks. He also called attention to the variation of the different forms.

The AUTHOR said that the subject of the passage between different so-called species of Nummulites alluded to by Prof. Seeley was very interesting. His own view was that all the forms of Nummulites passed into each other, the whole genus being in fact one very variable species.

10. *On the ECHINOIDEA of the CRETACEOUS STRATA of the LOWER NARBADÁ REGION.* By Prof. P. MARTIN DUNCAN, F.R.S., F.G.S.
(Read January 12, 1887.)

OWING to the kindness of H. B. Medlicott, Esq., F.R.S., Director of the Geological Survey of India, I have lately received a considerable number of specimens of Echinoidea, which have been obtained from recorded localities, from the Cretaceous formation, in the Lower Narbadá valley.

A small collection of Echinoidea, Mollusca, and Brachiopoda, and a coral are in the Museum of this Society, and they came from the neighbourhood of Bág on the Narbadá, in the same district whence the forms lately received were found. This small collection was described by me in a communication to this Society in 1865, another collection from S.E. Arabia being associated with it, and an Upper Greensand horizon was given to the strata containing the species (Quart. Journ. Geol. Soc. vol. xxi. p. 349). The persistence of many well-known European species into the far east was noticed. In 1866*, Messrs. Blanford and Wynne surveyed the Bág district, and decided that the succession of the Cretaceous rocks was, from below upwards, as follows:—Sandstone and conglomerate, 20 feet; nodular limestone, nearly unfossiliferous, 20 feet; argillaceous limestone, fossiliferous, 10 feet; and coralline limestone (Bryozoan) 10 to 20 feet. The relation of these conformable beds to the overlying Lameta beds and the Deccan and Malwa Trap was noticed.

The surveyors accepted my decision regarding the age of the beds which had yielded the fossils, namely the argillaceous beds near Deola and Chirákhán. In 1868† a similar horizon was stated to be present in the Sinai area; it was already known in Algeria; and later on, Fraas and Cotteau discovered it in the Lebanon.

The little collection from Bág became very interesting when Stoliczka's great work on the Echinodermata of the Cretaceous rocks of S. India was published; for none of the more northern forms were discovered by him. Yet the presence of the same geological horizon in S. India was placed beyond a doubt. (Pal. Ind. 1873, Cret. Fauna, vol. iv. 3, ser. 8, 3.)

In 1880 the trigonometrical survey having been completed, and a first-class map of the Lower Narbadá valley having been published, the Geological Survey of the district was seriously entered upon, the work of Blanford and Wynne being the basis. Mr. Bose was ordered to pay especial attention to the fossiliferous strata and the igneous rocks. The results of this survey were published in the Memoirs of the Geological Survey of India, vol. xxi. pt. i.,

* Mem. Geol. Surv. India, vi.,; see also Blanford, Geol. Bombay, Records Geol. Survey India, vol. v. pt. 3, 1872, p. 82.

† Quart. Journ. Geol. Soc. vol. xxiii. p. 38, and vol. xxv. p. 44 (1869).

1884, by P. N. Bose, B.Sc. (Lond.), F.G.S. Mr. Bose collected fossils in abundance, from the Nodular limestone, the Argillaceous limestone or marl, and also from the Coralline limestone. He found an *Ostrea*-bed on the top of the sandstone mentioned by Blanford, and his palæontological researches and stratigraphical results led him to adopt the following views :—

The age of the Sandstone is not settled, but the *Ostrea* on the top he believes to be *O. Leymerii*, d'Orb. ; it is Neocomian in Europe. The Nodular limestone rests conformably upon the *Ostrea*-bed and the Sandstone, and some of the same *Ostreae* are found in diminishing numbers in it. The Nodular strata Mr. Bose assigns to the Gault in one part of his work, and to the Albian and part of the Cenomanian in another. The Argillaceous limestone rests conformably upon the Nodular series, and contains the species formerly described in Quart. Journ. Geol. Soc. 1865, which were collected by Captain Keatinge. To this horizon Mr. Bose gives the correct names of Cenomanian with part Turonian. The Coralline limestone rests upon the Argillaceous limestone conformably, and after an examination of its fauna, Mr. Bose decides that it is Senonian in age. Mr. Bose, I regret to state, writes about the determinations of the species having been made by him “roughly ;” and it became evident, after studying his memoir, that there were not sufficient grounds for believing that the whole Cretaceous formation was represented in about 80 feet of conformable strata, the whole of the series from the Gault or Albian, to the Senonian inclusive, following conformably upon a Neocomian.

As Mr. Bose recognized some of the Echinoidea I had noticed, and as there was a good collection made from all the horizons, except the so-called Neocomian, I applied to Mr. Medlicott for the loan of the Echinoidea, with a view of describing them in the Records of the Geological Survey of India. Mr. Medlicott sent me the collection, as also one made by Mr. Blanford many years before, and that of Captain Keatinge, which had been placed in the Museum at Calcutta. The fossils in the Museum at Calcutta which had been collected many years ago by Captain Keatinge, came from the Argillaceous limestone or marl, and therefore were from the same strata as those which had been studied by me in 1865. Unfortunately this little group of well-preserved specimens was not studied by the last surveyor of the Cretaceous rocks, nor does it appear that he made himself acquainted with the forms which had been collected by Mr. Blanford. But Mr. Bose found some species in the collection which he made, and which I had not seen in the marl. In order to arrive at the truth with regard to the Echinoidea, I re-examined the collection in the Museum of this Society, and found that only one species required further consideration. It appeared to me that although the general shape of the *Echinobrissus* warranted the specific name I had given it, the details of the ambulacra were insufficiently seen. These details are well shown on a specimen which Mr. Bose obtained from the same horizon, and there is no difficulty in recognizing the petaloid condition of the postero-lateral

ambulacra which characterizes Cotteau's *Echinobrissus Goybeti* from the Cenomanian of the Lebanon.

I do not propose to alter the determinations of any of the other species of Echinoidea and Mollusca. The late Mr. Davidson was good enough to determine the Brachiopod to be *Rhynchonella depressa*, Sow., and this common Upper-Greensand species was found accompanied by a coral, *Thamnastræa decipiens*, Mich., from the same horizon. The commonest species in the collection in our Museum is *Hemiaster cenomanensis*, Cott., and the only apparent distinction between the type from the French Cenomanian and the forms from the Bág beds is that the posterior ambulacra in the specimens from India are not quite so broad as the others. All the specific characters are present. *Hemiaster similis*, d'Orb., is not uncommon, and two specimens are in our small collection. The identity of the French and Indian species struck me very forcibly, and the species is really a very distinguishable one. Hence the former determinations hold good except in one instance, and the necessary alteration strengthens the view of the Upper-Greensand horizon of the beds which yielded the fossils, or rather, as I put it, of the existence at Bág of a horizon from the top of the Gault to the base of the Chalk with flints.

The collection from the Museum at Calcutta was then investigated.

The first fossil examined was an exquisite *Salenia*, belonging to the group with very narrow ambulacra, and which has the two vertical rows of ambulacral primary tubercles so closely placed that there is no room for more than an occasional granule between them, in fact to the "petalifera" or "scutigera" group. The apical disk of the Indian form is ornamented with ridges and furrows in the usual radiating manner. But the species is not a new one, for it was recognized and described by the industrious and exact M. Cotteau in the collection obtained by Fraas in the Lebanon. Cotteau called it *Salenia Fraasi*, and it was found, in the first instance, in the Cenomanian deposits of the Lebanon. ('Ech. nouv. ou peu connus,' 2^e sér. fasc. 4, 1885, p. 59, pl. 8. figs. 1-5.)

There are numerous specimens of a *Cyphosoma* in the collection, and they are readily to be identified with the well-characterized *Cyphosoma cenomanensis*, Cotteau, from the French Cenomanian.

The other specimens are *Hemiaster cenomanensis* and *similis*.

Mr. Blanford's collection was from the marl near Dussai, 15 miles west of Mandoo, and many specimens came from the Coralline limestone at Chirákhán.

The specimens which could be named belonged to *Hemiaster cenomanensis* and *H. similis*. Hence Mr. Blanford has given us the evidence that there is a community of species between the marl and the overlying and conformable Coralline limestone.

Mr. Bose's collection from the marl was next examined. The two *Hemiasters* were found and also the *Cyphosoma* already mentioned. The *Echinobrissus* is named, according to Mr. Bose, on my authority, but I did not see it until a few weeks ago. Mr. Bose, however, gave me the opportunity, when I examined his specimen,

of correcting my former determination; and the species is *Echino-brissus Goybeti*, Cott., from the Cenomanian of the Lebanon. Several fairly well-preserved parts of a *Cidaris* were collected by Mr. Bose, and one or two belonging to the same species had been collected by Captain Keatinge and placed in the Calcutta Museum. These Mr. Bose considers to belong to *Cidaris cenomanensis*, Cotteau; but there are well-marked specific distinctions present, although the narrow ambulacra have four rows of interporiferous granules and the median suture is sunken in the interradia. The excessive size and irregularity of the warty granules beyond the scrobicular circles, and the proximity and large secondaries of these last-mentioned structures, are sufficient to separate the species, and, moreover, the Indian form is a large one. Mr. Bose was quite right in placing the form near to *C. cenomanensis*. It has been necessary to establish a new species for the form *Cidaris namadicus*, nob.*

An *Orthopsis* was found and recognized by Mr. Bose, and he appears to consider that it is *O. similis*, Stol., described from the Arriáalur strata of S. India. But there are specific differences; the Bág form has two of the radial plates not entering the periproctal ring, and the numerous rows of primaries do not extend so far up above the ambitus as in Stoliczka's species. The other supposed specimens of *Orthopsis* collected by Mr. Bose belong to the genus *Cyphosoma*.

It will have been observed that the Argillaceous limestone has a very interesting fauna, and it appears that *Nucleolites similis* also occurs as a variety, and this species of d'Orbigny brings the beds into relation with the Chloritic Marl of Europe.

The Echinoidea of the underlying Nodular limestone were next examined, and only two species could be identified from Mr. Bose's collection, and they are common. They are the two Hemiasters, *H. cenomanensis* and *H. similis*, the commonest forms in the conformable marl above. There are no Gault or Albian species present, and there are no stratigraphical data which will permit of the division of the few feet of beds into a Gault or Albian and a Cenomanian.

The Coralline limestone, which is above and conformable to the Argillaceous limestone, contains the following species:—*Cidaris namadicus*, nob., which also occurs in the Argillaceous beds below; *Cyphosoma cenomanense*, which has a similar vertical distribution; *Nucleolites similis*, var., *Hemiaster cenomanensis*, and *H. similis*: all these are met with in the limestone below, and the two Hemiasters are also found in the Nodular limestone.

Messrs. Blanford and Wynne, and also Messrs. Medlicott and Blanford, in the 'Geology of India,' considered that the Nodular limestones, the marl, and the Coralline limestones belonged to a conformable group, with a fauna indicating one Cretaceous horizon, and the examination of the collections of Echinoidea proves that these views are correct.

The age of the *Ostrea*-bed at the base of the Nodular limestone

* About to be described in the Records of the Geol. Survey of India.

is not considered in this communication ; for the specimens have not been examined in Europe.

The following is a list of the species of Echinoidea found in the Cretaceous series of the Lower Narbadá Valley:—

Name.	Nodular Lime- stone.	Marl.	Coral- line.	Foreign.
<i>Cidaris namadicus</i> , sp. nov.....	...	*	*	
<i>Salenia Fraasi</i> , <i>Cott.</i>	*	...	Lebanon, Cenomanian.
<i>Cyphosoma cenomanense</i> , <i>Cott.</i>	...	*	*	France, Cenomanian.
<i>Orthopsis indicus</i> , sp. nov.....	...	*
<i>Echinobrissus Goybeti</i> , <i>Cott.</i>	*	...	Lebanon, Cenomanian.
<i>Nucleolites similis</i> , <i>d' Orb.</i> , var.	...	*	*	Europe, Ch. Marl.
<i>Hemiaster cenomanensis</i> , <i>Cott.</i>	*	*	*	France, Cenomanian.
<i>Hemiaster similis</i> , <i>d' Orb.</i>	*	*	*	France, Cenomanian.

DISCUSSION.

Prof. AGASSIZ complimented Dr. Duncan on the work he had done on Echinoderms for the Geological Survey of India.

Mr. SLADEN considered it was undesirable that palæontological work should be criticized by any one who had not studied the actual materials upon which it was based. From his personal acquaintance with Dr. Duncan's extensive knowledge of the Echinoidea, he had full confidence in accepting the important deductions which the Author had laid before the Society.

Dr. BLANFORD explained the circumstances under which the hurried survey made by Mr. Wynne and himself was carried on around Bág in the month of May, the hottest season of the year; it was consequently not surprising that some of the conclusions had to be modified. On the other hand, he had already suspected that the palæontological evidence adduced by Mr. Bose in favour of referring the three limestone beds and the underlying sandstone to four distinct stages of the Cretaceous system was insufficient, and he was not surprised to learn that Prof. Duncan had found Mr. Bose's views to be untenable.

The most interesting point was the additional evidence of the great difference between the fauna of Bág on the one hand, and that of Trichinopoly of the same age on the other, the former being European, the latter containing a small percentage only of European forms. This supported the view already urged by the speaker that in Cretaceous times a land-barrier extended from India to South Africa.

Mr. WHITAKER said that in west Norfolk the whole of the beds from

Lower Greensand and Middle to Upper Chalk were to be found within 80 feet of vertical distance.

Dr. DUNCAN, in reply, said that the statement in the Memoir of the Geological Survey of India was, that the series from the Lower Greensand to the Upper Chalk inclusive was comprehended in 80 feet. In the English example there is a great difference between the fossils of the various strata ; this is not the case in the Bág beds.

11. *On certain DINOSAURIAN VERTEBRÆ from the CRETACEOUS of INDIA and the ISLE OF WIGHT.* By R. LYDEKKER, Esq., B.A., F.G.S., &c. (Read January 12, 1887.)

IN the year 1877 I published * a preliminary description of certain Dinosaurian remains obtained from the Lameta group of the Jabalpur district of India, to which I applied the name of *Titanosaurus indicus*. The Lameta beds, it may be observed, have been usually referred to the Middle Cretaceous (Upper Greensand), but later observations indicate that they may be of somewhat newer age. The remains on which the genus was founded are preserved in the Indian Museum, Calcutta, and comprise an imperfect femur, and a considerable number of late caudal vertebræ, together with one imperfect vertebral centrum from an earlier part of the series. In a later memoir † I gave figures of some of the more important of these specimens, and came to the conclusion that the vertebræ indicated two species, for the second of which I proposed the name of *T. Blanfordi*, adding the proviso that this form might eventually turn out to be generically distinct from *T. indicus*.

Both these types of late caudal vertebræ are characterized by their strongly procœlous centra, to the anterior half of which the anchylosed neural arch is confined; and in the one perfect specimen of *T. indicus* the arch carries two well-marked processes, one of which is directed anteriorly and the other posteriorly. The pre-axial process is bifurcated anteriorly, and bears a pair of prezygapophysial facets; while the hinder one, which (judging from the caudal vertebræ of the Sperm-Whale and of certain other Dinosaurs) I think includes the representative of the neural spine ‡, is single, and carries the postzygapophyses. In *T. indicus* the hæmal aspect of the bone presents two pairs of V-shaped ridges, on the extremities of each of which are a pair of well-defined facets for the attachment of chevron-bones, which look directly downwards; while the centrum is relatively short, with its hæmal surface placed nearly at right angles to the lateral surfaces and characterized by its extreme lateral compression. In the form to which the name *T. Blanfordi* has been applied the centrum is larger and subcylindrical, and the hæmal and lateral surfaces are not distinctly differentiated from one another, the ridges on the former surface are not present, and the facets for chevron-bones are either very indistinct or totally wanting.

These two types of vertebræ appeared to me to come nearest to those of *Cetiosaurus* and the so-called *Pelorosaurus* of the English

* Rec. Geol. Surv. Ind. vol. x. p. 38 (1877). One of the specimens had been previously described and figured (without name) in Falconer's 'Palæontological Memoirs,' vol. i. p. 418, pl. xxxiv. figs. 3-5.

† 'Palæontologia Indica' (Mem. Geol. Surv. Ind.), ser. 4, vol. i. pt. 3, p. 20, pls. iv. & v. (1879).

‡ Many writers adopt a different view in describing analogous specimens.

Wealden, in which the centra are amphiœlous; and also to those of the much smaller *Macrurosaurus** from the Cambridge Greensand, in which there is a slight procœlous character in some parts of the series, and distinct facets for chevron-bones are wanting. Their extreme procœlous character seemed, however, so peculiar that at a later date † I thought myself justified in assigning *Titanosaurus* to a new family of the Sauropoda.

Thus the matter stood till some few months ago, when Mr. W. Davies, of the British Museum, directed my attention to two vertebral centra in the Collection under his charge, which had been obtained by the late Mr. Fox from the Wealden clay of Brook in the Isle of Wight. These centra, as Mr. Davies pointed out to me, agree in general characters with those of *Titanosaurus*, and almost certainly belonged to a closely allied form. The least imperfect of the two specimens, which is figured (with the neural arch restored) in the accompanying woodcut, comprises the whole of the

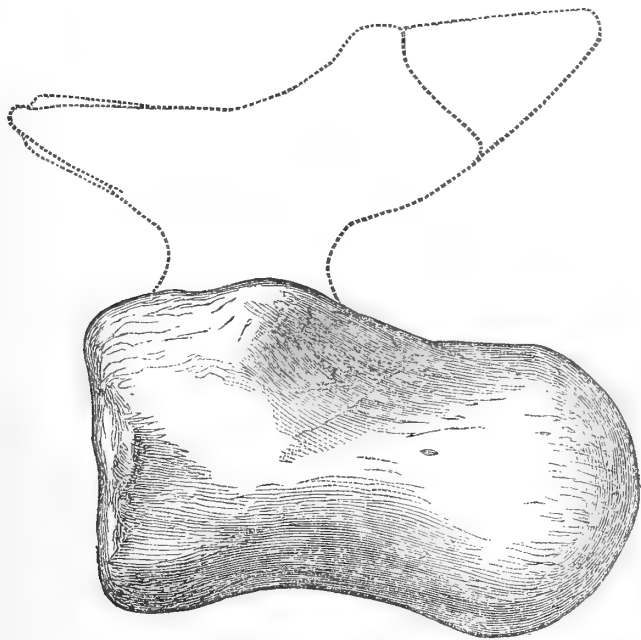

Caudal vertebra of a Dinosaur, with the neural arch restored; from the Wealden of Brook, Isle of Wight. $\frac{1}{2}$ nat. size. British Museum (No. R. 151).

centrum and the base of the ankylosed neural arch. The two extremities are somewhat rolled and water-worn, and have thereby lost somewhat of their original roundness; but in general contour, as well as in size, in the form of the articular surfaces, in the position of the base of the neural arch, and the apparent absence of distinct facets for chevron-bones, this specimen agrees very closely with the centrum of *Titanosaurus Blanfordi* represented in pl. v. fig. 3 of the memoir in the 'Palæontologica Indica' which has been already

* Seeley, Quart. Journ. Geol. Soc. vol. xxxii. p. 440 (1876).

Palæontologica Indica, ser. 4, vol. i. Introductory Observations, p. v (1885).

quoted. The centrum is, however, more compressed in the English specimen, while the hæmal and lateral surfaces are distinctly differentiated from one another, and the former surface carries a pair of V-shaped ridges resembling those of *T. indicus*. The specimen is in fact very nearly intermediate in character between the figured vertebræ of *T. Blanfordi* and *T. indicus*. The abrasion of the rim of the articular cup shows that the internal structure of the bone is coarsely cancellous. The second specimen (No. R. 146 a) comprises the anterior half of the centrum of a slightly smaller vertebra, and has been but little rolled. This specimen shows on the ventral aspect the well-marked V-shaped ridges so well displayed in the type specimen of *T. indicus**, but lacks the distinct chevron-facets of that form.

We may then, I think, consider it most probable that the English specimens indicate the occurrence in the Wealden of a Dinosaur closely allied to *Titanosaurus*; and it now remains to consider whether, in the first place, they can be referred to any genus already described from those beds, and, in the second place, whether or not they should be regarded as generically identical with one or both of the Indian forms provisionally included in the above-mentioned genus.

With regard to the first question, among the large Dinosaurs of the Wealden the caudal vertebræ of *Iguanodon* and its allies are of a totally different type from the present specimens; while equally different are those of *Cetiosaurus* (with which may be grouped the so-called *Pelorosaurus*), as well as those of *Megalosaurus*, in both of which genera the centra have either flattened or slightly hollowed articular surfaces. Turning, however, to the gigantic *Ornithopsis*, we find that the caudal vertebræ have not been hitherto known †, and there is accordingly a strong *primâ facie* presumption that the specimens under consideration may belong to that genus. The nearest allies to *Ornithopsis* are certain North-American Dinosaurs included in Marsh's Sauropoda ‡, such as *Brontosaurus*, *Morosaurus*, *Camarasaurus*, *Amphicælias*, &c.; in these, while the precaudal vertebræ have cavities in the centrum like those of *Ornithopsis*, those of the caudal region are solid. Apparently in all the American forms the centra of the caudal vertebræ are amphicæulous, while those of the cervical region are opisthocæulous; since, however, in some genera, such as *Camarasaurus* §, the dorsal vertebræ are opisthocæulous, like those of *Ornithopsis*, while in others, like *Amphicælias* ||, they are amphicæulous, there is apparently no reason why similar variations should not also occur in the caudal region of other members of the group. In *Brontosaurus*, where

* Palæontologia Indica, ser. 4, vol. i. pt. 3, pl. iv. fig. 1.

† See Hulke, Quart. Journ. Geol. Soc. vol. xxxvi. p. 36. There apparently is no reason why the amphicælian vertebræ there mentioned should not belong to *Cetiosaurus*, since they agree closely with the specimens from the Great Oolite figured in Phillips's 'Geology of Oxford.'

‡ See Marsh, 'Amer. Journ.' vol. xxiii. p. 83 (1882), and vol. xxvii. p. 167 (1884).

§ Proc. Amer. Phil. Soc., Dec. 21, 1877, p. 237.

|| Ibid. p. 243.

the dorsal vertebræ are amphicœlous, Professor Marsh's* figure and description show that the hinder caudals have neural arches of the precise type of those of *Titanosaurus*, while the form of the middle part of their centra is apparently very similar to that of the specimens under consideration. In *Camarasaurus*, again, the centra are laterally compressed as in *Titanosaurus indicus*, although the facets for the chevrons are less strongly marked. *Camarasaurus* and *Amphicœlias*, it may be observed, are of Cretaceous, while *Brontosaurus* is of Jurassic age. The suborder Sauropoda is taken to include *Cetiosaurus*, which, although none of the vertebral centra are hollowed, is evidently allied to *Ornithopsis*; while it is probable, judging from the structure of the caudal vertebræ, that *Macrurosaurus* should also be placed in the same division. There appears therefore to be at least a considerable degree of probability that the Wealden vertebræ may belong to *Ornithopsis*; and if they do not it is pretty certain that they do not belong to any other previously known English genus.

With regard to the second question—*i. e.* whether these vertebræ, which may be provisionally referred to *Ornithopsis*, are generically identical with one or both of the two forms described under the name of *Titanosaurus*—there is far less possibility of arriving at present at any very satisfactory conclusion. It will, however, be safe to say that if the characters which distinguish the vertebræ of *Titanosaurus indicus* from those of *T. Blanfordi* eventually prove to be of not more than specific value, then the English vertebræ might well be also generically identical, in which case *Titanosaurus* should be merged in *Ornithopsis*. If, however, on the other hand, the vertebræ described under the name of *T. Blanfordi* should turn out (as it is highly likely that they will) to be generically distinct from *T. indicus*, then there would also be very considerable probability that the Wealden specimens are likewise generically distinct from both the Indian forms, although their relationship appears nearest to the form called *T. Blanfordi*.

Under these difficult circumstances the only prudent course is to consider that we have evidence in India and Europe of three apparently closely allied Dinosaurs clearly marked off from all other described forms by their strongly procœlous later caudal vertebræ, and for the present to retain the generic name *Titanosaurus* for the type Indian species, to refer the Wealden form provisionally to *Ornithopsis*, and to leave it open whether the form to which the name *Titanosaurus Blanfordi* has been applied is generically identical with one or other or even both of these forms, or whether it should form the type of a third genus †.

In conclusion, it may be observed that the occurrence in the

* Amer. Journ. vol. xxvi. pl. i. (1883), and vol. xxi. p. 420 (1881).

† In my description of *Titanosaurus* I mentioned a larger vertebral centrum which I regarded as precaudal and procœlous. Since, however, similar vertebræ, which are opisthocœlous, occur at Brook, the two types may respectively belong to the early caudal region of the Indian and European Dinosaurs, as the *Crocodylia* and *Macrurosaurus* show that the form of the articular surfaces of the centra may vary in different parts of the caudal region.

higher Cretaceous of India of two species of Dinosaurs apparently closely allied to one from the lowest Cretaceous of Europe seems to be another instance of the survival in India of allied or identical generic types to a date after they had disappeared from Europe. A somewhat similar instance is afforded by the occurrence of *Megalosaurus* in the Arriâlur group (white chalk) of Trichinopoly in Southern India*—that genus being mainly characteristic of the Wealden and Stonesfield Slate, although lingering on to the Maestricht beds †—and also by the oft-quoted Siwalik fauna. I may also observe that if the Wealden vertebræ really belong to *Ornithopsis*, then we shall have good evidence of the distinctness of that genus from the North-American *Camarasaurus*, with which it has been identified by some writers—a distinction which might, I think, justify the reference of the English genus, together with *Titanosaurus*, to a separate family, the Ornithosidæ.

Finally, I may express a hope that the Officers of the Geological Survey of India will direct their attention to the acquisition, from the Lametas of Pisdura, of other remains of Dinosaurs which may include vertebræ of the precaudal region, and thus indicate the true relationship of *Titanosaurus* to *Ornithopsis*.

DISCUSSION.

Prof. SEELEY regretted the absence of the Author. The vertebra on which *Titanosaurus* was founded had long been known in England, but was considered insufficient to enable the relations of the animal to be determined. The femur had not been figured. The characters of the vertebræ were insufficient to show that there was any affinity to *Cetiosaurus*, and *Pelorosaurus* was only a species of *Cetiosaurus*. The speaker considered that the vertebræ from the Isle of Wight were also insufficient for identification. The facets supposed to be those for the attachment of chevron-bones looked forward and outward, so that it was very questionable whether they were facets at all.

The affiliation to *Ornithopsis* rested on insufficient evidence. There was more similarity with *Macrurosaurus*, but the centrum in that genus is cylindrical. Although a large portion of the caudal region of the vertebral column of *Macrurosaurus* was known, its affinities were very doubtful.

Mr. HULKE concurred with the Author in thinking that the close similarity of the Indian and the Isle-of-Wight vertebræ warranted the assumption of a generic, if not specific identity. He had never (nor, he believed, had Mr. Fox) found these vertebræ in the beds hitherto yielding the remains of *Ornithopsis*, and he was inclined to regard their reference to this Dinosaur only as provisional, the view taken, he understood, by the Author.

* Palæontologia Indica, ser. 4, vol. i. pt. 2, p. 26.

† Vide Seeley, Quart. Journ. Geol. Soc. vol. xxxix. p. 246 (1883).

12. *On a MOLAR of a PLIOCENE TYPE of EQUUS from NUBIA.* By R. LYDEKKER, Esq., B.A., F.G.S., &c. (Read December 15, 1886.)

A SMALL collection of mammalian remains, obtained during the late Soudan expedition by Brigade-Surgeon Archer at Wadi Halfa and other places in Nubia, has been submitted to my notice by Dr. Woodward. Many of the specimens are evidently of comparatively recent origin; but those from Wadi Halfa are in much the same mineral condition as the bones from the Upper Pliocene of the Val d'Arno in Tuscany, or the Lower Pleistocene of the Narbada valley in India. Among these remains are several specimens belonging to a large species of *Bos* or allied genus, which do not admit of any attempt at specific determination; but they also comprise an upper molar of an *Equus*, which is of very considerable interest.

It may be well to recall that so long ago as 1865 the late Dr. Falconer described, in the Society's Journal*, part of the left maxilla of a Hippopotamus obtained from fluviatile beds at Kalábshi (Kalábshee or Kalábsheh), a village situated on the Nile a short distance above the first cataract at Assouan, and about 150 miles north of Wadi Halfa, which is at the second, or great cataract. Dr. Falconer referred his specimen, which he observed was in the same state of mineralization as the Val d'Arno fossils, to the existing *H. amphibius*, although remarking that it agreed in size with the teeth of the Pliocene Val d'Arno form, which at that time was regarded as specifically distinct.

The specimen forming the subject of the present communication (figured from the crown-surface in the accompanying woodcut)

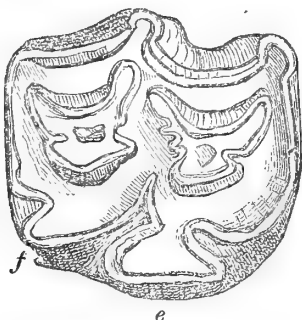

Equus, sp. A right upper cheek-tooth (? *m.1*), from the Upper Tertiary of the Nile valley at Wadi Halfa. †. *e* anterior, and *f* posterior inner pillar.

consists of a right upper cheek-tooth, which, from its comparatively small size, is probably the first or second of the true molar series,

* Quart. Journ. Geol. Soc. vol. xxi. p. 373. See also the writer's 'Catalogue of the Fossil Mammalia in the British Museum,' part ii. p. 279, No. 40855 (1885).

and is in a comparatively early stage of wear. The small antero-posterior diameter of the anterior inner pillar (*e*), and especially the slight production of the part of this pillar placed posteriorly to the "neck," or point of junction with the main body of the crown, indicates that the specimen does not belong to any of the later Pleistocene or recent species of the genus, but to that more generalized group comprising *E. sivalensis* of the Pliocene of India, and *E. Stenonis* of the Upper Pliocene of the Val d'Arno and Algeria and of the Norfolk Forest-bed*. With regard to the upper cheek-teeth of those two forms, which Dr. Forsyth-Major † regards as identical, it appears that in the former the crown-surface of the antero-internal pillar is on the average decidedly more elongated than in the latter ‡, and that it has a greater tendency to the production of its anterior extremity in advance of the "neck," in which respects it makes an approach to *E. quaggoides*, F.-Major §, and is thereby connected with the recent species of the genus. Now in the form and connexions of the pillar in question the Nubian tooth agrees so exactly with the Indian species (being, indeed, absolutely undistinguishable from the first true molar of the maxilla of the opposite side represented in pl. xiv. fig. 2 of the 'Palæontologia Indica,' ser. 10, vol. ii.) that, if found in India, it would be unhesitatingly referred to that species.

When, however, we call to mind the apparent impossibility of distinguishing many of the existing species of the genus by their teeth alone, it would be rash to say that the Nubian fossil belonged to *E. sivalensis*; and it will accordingly be advisable to regard it as apparently indicating the occurrence in that region of a species belonging to the same group, and also as affording pretty conclusive evidence that the ossiferous beds of Wadi Halfa, and probably, therefore, those of Kalábshi, are either of Lowest Pleistocene or of Upper Pliocene age, since this group of horses, both in Europe and Algeria, and in India is unknown after the period of the Norfolk Forest-bed, which is either lowest Pleistocene or highest Pliocene.

The specimen is, however, of interest from another point of view. I have previously expressed an opinion || that the modern African genera, found in the Pliocene of India, may have reached Africa by way of the Gulf of Aden; and it is therefore of especial interest to find in the Tertiary of Nubia a member of the primitive group of the genus *Equus*, which is apparently more nearly allied to the Siwalik than to the European species. The occurrence of *Hippopotamus amphibius* in the same deposits indicates, however, that the early fauna of this part of Africa was also connected with that of Pliocene and Pleistocene Europe, although this connexion was, perhaps, not so close as in Algeria, where we find in the Pliocene

* See 'Cat. Foss. Mamm. Brit. Mus.' pt. iii. p. 71 (1886).

† Quart. Journ. Geol. Soc. vol. xli. p. 2 (1885).

‡ Compare the figures given by the writer in the 'Palæontologia Indica,' ser. 10, vol. ii. pl. xiv., with those given by Forsyth-Major in his "Geschichte der fossilen Pferde, etc." (Abh. schwz. pal. Ges.), pls. i., ii.

§ *Op. cit.* pl. ii. fig. 1.

|| Quart. Journ. Geol. Soc. vol. xlii. p. 175 (1886).

teeth which are undoubtedly referable to *Equus Stenonis* accompanied by others which not improbably belong to *Elephas meridionalis* *.

If further collections of mammalian remains should eventually reach us from the valley of the Upper Nile, I think we may confidently expect that they will afford important information with regard to the relations of the Pliocene faunas of India and Europe with the existing fauna of Africa.

[P.S.—The observations of Drs. Woodward and Blanford mentioned below, in regard to the remains of Deer from the Wadi Halfa beds, lend support to the view taken above as to the comparative antiquity of those deposits.]

DISCUSSION.

The PRESIDENT remarked that all the materials for the evening's work had been supplied from the British Museum (Natural History).

Dr. WOODWARD spoke of remains of Deer and *Bos* which appeared to be in the same mineralized condition as those of *Equus*; they were well-fossilized bones from high above the present Nile level, and were probably of Tertiary age.

Dr. BLANFORD spoke of the occurrence of fossil Deer in Nubia as extraordinary, since the true Deer now only occur in North Africa, none east of the Sahara, where the Deer are replaced by Antelopes. The link shown with Indian Tertiaries was important. The fact recently ascertained by Mr. Lydekker that true Baboons existed in Pliocene Siwalik beds and even later, showed a resemblance between the Indian and African faunas. All this pointed to a different distribution of land during the late Tertiary period in the Persian Gulf and Straits of Bab-el-mandeb. Signs of depression may even now be seen in the former.

Dr. HICKS pointed to the three stages of development shown in the drawings of teeth exhibited, and asked, why do we find a higher form in association with a lower?

Mr. E. T. NEWTON remarked on the little that was known of fossils from that part of Africa, and thought the Deer-antler alluded to by Dr. Woodward even more interesting than the Horse's tooth. The teeth of the Recent and Pleistocene Horses were extremely difficult to distinguish, and he thought the tooth exhibited might have belonged to one of the existing African species. Was there any other evidence as to the probable age of the beds? The Deer would seem to indicate earlier beds than could be inferred from the presence of the Horse.

Dr. WOODWARD observed that the remains came from different deposits, but the piece of Deer's antler was certainly associated with the tooth of Horse.

The PRESIDENT said that amongst some remains brought from the Soudan was a tooth decided to have been that of a very large Antelope.

* See 'Cat. Foss. Mamm. Brit. Mus.' pt. iv. p. 108 (1886).

The AUTHOR, in reply, remarked that *Equus Stenonis*, in Algeria, is associated with the remains of Deer. *E. Stenonis* is intermediate between *Hipparion* and *E. caballus*; but it is impossible at present to say where the evolution connecting these forms took place. He concluded that the evidence was in favour of the species being one of those which disappeared towards the close of the Pliocene period.

13. *The TERRACES of ROTOMAHANA, N. Z.* By JOSIAH MARTIN, Esq., F.G.S., Auckland, N. Z. (Read February 9, 1887.)

THE destruction, by explosion connected with the eruption of Tarawera, 10th June, 1886, of the world-renowned Terraces of Rotomahana invests with a melancholy interest the subject of this paper. A calamity so complete and overwhelming that not a vestige of these magnificent monuments of Nature's architecture remains to mark their site, has called forth expressions of sincere regret, not merely from the inhabitants of New Zealand, but also from every student of Nature's phenomena, every lover of the picturesque and beautiful, as well as from every casual visitor to this wonderful district.

As the chief centre of attraction to tourists through the Hot-Lake district, the Terraces of Rotomahana have been frequently described. Poets, men of science, and historians have endeavoured to express in varied language the impressions which these unique structures have produced upon them, while painting and photography have made known to some extent their delicacy of colour and variety of form. Most of the writers have, however, admitted their inability to give, from a rapid survey of the whole, more than a brief and incomplete description. In fact nothing beyond a generalized or vague idea could be acquired, except by a prolonged residence on the spot, a close familiarity with the place in all its varying aspects, a continuous study of the marvellous range of phenomena, and an intimate acquaintance with and patient observation of their periodicity and more salient characteristics.

The largest and most important structure, but lately so well known as the White Terrace, was of very recent geological formation. Its origin, the Terata Geyser, was situated in a crater-like hollow near the centre of a conical hill of steaming and partially decomposed felspathic tuff on the south-east side of the warm lake Rotomahana. Outspreading fan-like from its cauldron, 100 feet above the lake, and descending by terraced steps of white sinter in a sector of 60° to a broad flat of indurated mud, it encroached upon the lake with a wide sweeping curve measuring 800 feet (see fig. p. 167). The distance from the apex to the frontage was equal to a radius of 800 feet, and the measurement gives an area of about 320,000 square feet or about $7\frac{1}{4}$ acres.

The Terrace was divided by marked differences of structure and elevation into:—

1. The Upper Terrace, with its long horizontal lines of cups steaming and overflowing with hot water.
2. The Middle Terrace, with its massive steps and shaggy fringes without basins or receptacles for the overflow.
3. The Lower Plateau, a series of shallow basins and wide level platforms.

Measurements along a line of radius from the lake to the summit gave the following results:—

		Radial measure- ments.	Elevation. Average.	Temperature of overflow.
		ft.	ft.	
Lower Plateau.	{ 1. Lake-flat.....	80	1 or 1 in 80	60° to 80°
	{ 2. Lower plateau	66	4 = 3° 5' or 1 in 16	80° to 90°
	{ 3. Cold-water Basins.....	150	10 = 3° 5' or 1 in 15	60° to 90°
Middle Terrace.	{ 4. Tabular masses and slopes	240	50 = 11° 5' or 1 in 5	80° to 112°
Upper Terrace.	{ 5. Hot-water Basins	250	35 = 7° or 1 in 8	115° to 160°
	{ 6. Upper platform	30	Level	160° to 170°

The Great Cauldron, or Basin, when empty, appeared to be an extensive excavation lined, decorated and richly ornamented with the characteristic deposit of snow-white sinter. Its form was elliptical, with a longer diameter of 200 feet and a shorter of 165 feet.

The sides of the Cauldron formed a nearly vertical wall 10 feet high, which extended about halfway round on the east side, the other portion sloping inward at an average angle of 30° to a depth of about 20 feet, except under the "Lion Rock," where a magnificent cornice overhung a perpendicular wall 14 feet in height.

The basin-floor was broken into large irregular masses, the whole surface being roughly corrugated into wavy lines (probably caused by convection-currents) and presenting the appearance of wind-drifted snow.

The Cauldron was enclosed by a smoothed and perfectly level rim of silica, about 6 feet in average width.

This enclosing rim formed a pathway round the Cauldron, except on the south side, where its continuity was broken for a distance of 40 feet, being perforated by a number of small steam-holes.

The crater-walls, excavated from the hill by hydrothermal action, rose abrupt and dark from the outer circumference of the rim.

From 50 feet in height behind the Cauldron this wall sloped, as it embraced the hollow, to the sharp ridges which formed the side of the entrance, and, with the "Lion Rock," probably, at an earlier period, completed the circuit at a height of from 12 to 15 feet above the level of its recent overflow.

The opening to the upper platform in front of the Cauldron

extended 123 feet, and near the middle stood the "Lion Rock," a mass of harder material (which had resisted disintegration), 35 feet in length at its base and 10 feet in height. This encroached considerably within the elliptical area of the Cauldron, rendering its surface reniform in contour.

*Sketch Plan and Section of the White Terrace, Rotomahana,
in November 1885.*



Lake Rotomahana.

The opening to the Tunnel was situated about 30 feet to the south-west of the centre of the basin, at a depth of 30 feet below the rim; it measured 15 feet across, narrowing at a further depth of 8 feet into a tube apparently 6 feet in diameter.

The activity of the Geyser varied greatly. From furious ebullition with a rushing overflow fully 10 inches in depth across the whole opening, it would subside into its normal discharge, welling up and

over in ripples of about one inch in depth; frequently the overflow would cease, fluctuations continuing within the basin; and occasionally the water retired altogether within the tube, leaving the basin dry.

During rapid alternations of activity and rest the whole contents of the Cauldron have been observed to retire within the tube in six hours, and the most rapid refilling noticed has taken four hours to complete.

The process of refilling sometimes commenced slowly and was continued steadily, while at other times the action would be spasmodic, and violent eruptions of water would be thrown to an enormous height, sometimes falling beyond the area of the basin.

From the measurements taken of the interior of the Cauldron, its capacity would be about $2\frac{1}{2}$ million gallons.

From numerous and independent observations the activity for 100 days may be stated as:—

	days.
1. Excessive.—Violent disturbances, basin filling in 4 hours with overflow of 600,000 gallons per hour	2
2. Extraordinary.—Basin filling in from 6 to 12 hours, overflow from 200,000 to 400,000 gallons per hour	8
3. Normal.—Constant ebullition in basin, dense steam-clouds, frequent geyser-fountains from 20 to 30 feet above surface, water welling over in rippling waves at 100,000 gallons per hour	75
4. Feeble.—Reduced geyser-action, water rising and falling within the basin, little or no overflow	10
5. Quiet.—Water low, showing floor of basin	3
6. Dry.—Water all retired within the tube	2
	100

Heavy N.E. weather, with falling barometer, was usually associated with excessive action; the water frequently retired, leaving the basin dry, when the wind was from the south, with a clear sky and rising barometer.

Closely comparing the movement of the aneroid with the periodicity of action gave, however, very unsatisfactory results. For three days the activity of the Geyser exactly corresponded with the movement of the barometer—overflow ceasing and the water retiring into the tube when the barometer was rising and wind changing from W. to S., and activity being resumed directly the barometer indicated a downward tendency and the wind shifted toward N.E.

On three following days similar changes of activity took place under exactly opposite conditions as to wind and barometric pressure. During six days succeeding the overflow continued normal, although similar atmospheric changes were experienced.

An approximate analysis of the water gave about 150 grains of solid matter per gallon, viz. :—

Silica, free and combined with soda	grs. 50
Sodium and potassium chlorides.....	60
Alkalies, chiefly soda	30
Sodium sulphate, and other salts.....	10
	150

The amount of rock material thus withdrawn in solution by this geyser at its normal rate of discharge would amount to about ten tons per day. Several observations lead to the conclusion that at least ten per cent. of the silica would be deposited upon the surface covered by the overflow. This would be equivalent to about 120 tons per year, and give an average deposit over the entire surface of one inch in fifteen years. Upon the upper portions of the structure the deposit had formed as rapidly as one inch in five years upon various objects placed for experiment in the course of the overflow.

The *Upper Platform* extended east and west in front of the basin for 130 feet. Its width at the west end was 15 feet, and at the east 10 feet. In front toward the centre it opened out into two large shallow basins. The larger (No. 2 on plan) circular in outline with a diameter of 60 feet, the other (No. 3) semicircular, with a curious double outer rim, had a radius of 20 feet, and between them was a slightly depressed channel 4 feet wide. The outer (eastern) portion of the platform was very curiously broken into miniature lakes and islands, with peninsular points and crescented bays. The surfaces of the elevations were smooth, and of uniform level with the rest of the platform and rim of Cauldron (No. 1). These small depressions, as well as the hollows of the two basins (Nos. 2 & 3), had the nearly uniform depth of twelve inches. The sides of the elevations and the floor of the depressions were covered with delicate coral-like deposits of exquisite beauty.

When the platform was covered by the overflow, these numerous and beautiful depressions escaped notice, the whole surface appearing as a level sheet of water, the visitor being cautiously conducted along the narrow path in front of the rock over which the water would be rippling from the Cauldron.

The double outer rim of No. 3 basin enclosed a deep and beautifully ornamented *crescent*, a yard in width at the widest part. The sides and depths were covered with projecting and interlacing points of coral-like sinter, similar in character and disposition to the fleecy masses which were scattered over the basin floor and which promised in time to fill up the entire cavity.

This seemed to afford strong evidence that the *crescent* as well as the other depressions could not have been excavated by the same agency as that by which they were slowly but certainly filling.

The breach or outer wall of this (No. 3) basin formed a wavy semicircle ten yards in extent and about six feet in height, thickly set with rough projecting bosses and mammillary points.

The outwork of No. 2 basin formed a massive wall ten feet in height, with similar decorations, and presented a conspicuous appearance when the terrace was viewed from the lower levels. The wondrous horizontal lines of "cups" were situated immediately below, on the west and east points of the Upper Platform, meeting the circular walls of the basins; joining at their base, these continued the regular parallels right across the front of the Terrace.

The tiers or rows of "cups" might be classed in four sections, each with its own specialized structure and form:—

1. East lines, slope 1 in 8.
2. West lines, slope 1 in 5.
3. Steep basins (central), slope 1 in 3.
4. Lower series, slope 1 in 10.

(1) Upon the upper eastern portion their crisp and sparkling lips projected like open bivalve shells, overhanging half the cup beneath; seen from below they formed long lines of varying height but perfect in their horizontality; and in section they would appear as a series of crescents, set with points projecting upwards.

(2) On the other portions of the upper slope the projecting rims were reduced and rounded, and formed perpendicular walls with protuberant lips.

(3) Under the walls of basins Nos. 2 & 3 these receptacles were steeper and bolder, and formed a series of *Decorated Basins*, which being a little distance from the beaten track were rarely seen by visitors. Their elevations were curiously embossed and adorned with rosette-like appendages, which, when the Terrace was partially dry, stood out white in bold relief upon a grey ground, and presented to the spectator a more perfect ideal of rich ornamentation than could be seen elsewhere on any part of this wonderful structure.

(4) The lower series of enclosures opened out into wide shallow areas, bounded by low narrow sinuous ridges, almost unnoticed when dry, but strongly defining the differences of elevation when covered by the overflow. When seen full and overflowing from above, these receptacles appeared as segments of azure, outlined with arcs of creamy white, infinite in variety of size, from a semicircle a few inches in diameter, to long and wavy outlines of from 50 or 60 feet, enclosing pools from one to six feet in width, with a few larger areas showing a deeper blue outlined in firmer lines.

In this series of "cups" the silica was deposited by rapid evaporation in a granular form, and when dry had the dazzling brilliancy of frost-work; yet so firm and adherent were the particles that they were with difficulty crushed or scraped away, the outer rim or edge being more compact than the interior.

The upper and lower portions of the Terrace were distinctly separated by the great wall, popularly known as the *Giant Buttress*, which extended its level summit in a wavy outline for more than 80 feet, supporting the shallow pools of the Upper Terrace. Its front was draped with overlapping wool-like fringes and stalactitic pen-

dants, from which the overflow trickled in a glistening shower. This was the most conspicuous portion of the whole structure, the gradual descent of the formation on either side leaving the centre overhanging more than twelve feet above a basin which beautifully reflected its curious architecture.

This natural division was also marked by a level path varying in width from 2 to 20 feet, which extended right across the face of the Terrace from east to west, broken only by a few steps near the centre.

Upon this belt, and almost exactly in the centre of the Terrace, was the rough protruding rock known from its peculiar shape as the *Boar's Head*.

A little further towards the east was the *Broken Basin*, a circular pool 12 feet in diameter, about 26 inches deep, of similar height upon its outer front, the only warm-water basin on the White Terrace deep enough to be used as a bath; its temperature varied, according to the overflow, from 120° to 90°, its interior surface was rough like concrete, and a sedimentary deposit was disturbed when bathing. Some time ago an opening must have been roughly hewn out of the rim, forming a depressed lip about 12 inches across and 4 inches deep, through which the overflow poured into another shallow basin below.

The deposition of sinter here must have been very slow, as scratches and markings made in the hollow of the broken lip two years since were barely covered by a thin glaze.

The Middle Terrace.

The central portion of this part of the structure was distinguished by a series of massive, rugged, and rippled perpendicular elevations, many of which exceeded six feet in height; some were decorated with pendent wool-like fringes, some with deeply engraved parallel lines, and others with small upturned scales. The central ones were approached on either side by lower ridges, which together formed an ascent of about two hundred steps. At increasing distances from the centre, these elevations were again and again reduced until, near the margin, they merged into wide incrustated slopes marked by lines of interlacing ripples which formed protecting ridges less than half an inch in height.

These elevations, although presenting the characteristic lines of level surface, formed compact platforms, tables, or steps—only one depression occurring in the whole series, and that but a small muddy pool.

Although the normal overflow covered the whole of the Terrace, any diminution in quantity left many of these central masses dry. The deposition of silica appeared to be scarcely sufficient to preserve the compact character of the surface, and those parts most exposed to the action of the atmosphere were disintegrating and becoming loose and fragmentary.

It seems but reasonable to suppose that these central elevations

had been formed before the lateral slopes were cleared of vegetation, as such masses could scarcely have been deposited by aqueous agency if such a free outlet as the sloping sides had been open to the escaping flood.

The *Eastern Wing* of the Terrace, divided from the Middle Terrace by a clump of stout manuka trees, formed a steep slope of sinter deposit rippled into small wavy lines. Under the trees some very interesting features of new formation were observed, the prostrate branches forming the foundation of ridges, and drifting twigs and leaves collecting in the hollows became incrustated and cemented, forming receptacles similar in character to those upon the Great Terrace.

The *Western Wing* was separated by a deep cleft and some smaller clumps of bush. Its deposit was similar in character to that of the east wing. Its lower portion was more extensive and formed wide shallow areas, bounded by ridges of from one to three inches in height; these frequently contained beautiful tree-like accretions, which rising on a stem, spread their branches on the surface, the largest specimens extending over four inches.

The *Cold-water Basins* formed the front extension of the lower central portion of the Terrace. Viewed from above, they exhibited an extraordinary combination of circular and crescented areas, extending from five to twenty feet across, of pale, opalescent blue, outlined by broad rims of grey and brown, with encroaching margins of siliceous mud.

From below they formed an ascending series of from one to four feet in height, with rough perpendicular walls, in some instances with a slightly projecting cornice, streaked with vertical lines of white, grey, and brown, mingled with various stains.

Their depth appeared to correspond to their height. The surface-water was cloudy from suspended silica, and the basins full of a fine siliceous ooze, gelatinous and cold. The contents of these receptacles showed every stage of consolidation, and many had already become compact tabular blocks. The conversion of the alkaline silicates into carbonates by exposure to the atmosphere would precipitate the silica in the forms observed in these basins.

The outward trend of every curve in this wonderful series, and the gradual descent from the apex or summit, seems to indicate their origin from the great cauldron above. The theory of the formation of the structure from siliceous deposition only fails to account for the erection of such regular basins at such a distance from the source, the cooled overflow leaving here so little surface-deposit; and further the excavation of the basin-hollows could scarcely have been effected by the same agency as that by which they were now consolidating.

The Lower Plateau skirting the Terrace on the lake-border marked by its regular gradations the gradual lowering of the lake-level through a distance of about four feet. Along the edge of the Terrace it formed a sinter pavement, loose and fragmentary, readily detached in surface-layers of about an inch in thickness. In many

places it was broken through by clumps of trees or small shrubs, and many rush-covered patches appeared on the softer parts.

Towards the lake the margin became uncertain and treacherous, and the boundary between terrace-deposit and lake-mud was undefined.

Changes in Appearance.

The want of a series of systematic observations of the rate and form of deposit can never be supplied.

Comparing photographs and notes taken in 1883 with experiences two years later, it was found that marked changes were taking place upon the upper part of the Terrace.

The surface previously covered by an acicular deposit had now a more granular character, and instead of crunching under foot like hoar-frost, it had the yielding nature of a layer of snow.

The overflow had also worn a slightly depressed channel, leading from the cauldron across the platform, between the two shallow upper basins already described. The flood rising to the lip of the cauldron flowed through this channel and poured down the centre of the Terrace.

The erosion of this stream was evidently deepening its own channel and smoothing the surface of those masses over which it poured, while it threatened in time to alter the whole appearance of the Upper Terrace.

As the water rose more rapidly than it could escape by this new channel, it next filled the circular outer basin (No. 2), and then the other large area (No. 3); a further rise spread over the western end of the platform and down the trees on that side, the receptacles on the east side being supplied by a cooler stream overflowing from the basin (No. 3).

This change of direction from that of the previously characteristic uniform overflow was also apparent in the orange coloration which was extending over the eastern tiers, probably due to confervæ. The temperature of the water in these depressions was only 100°, while in those at the same level on the western side it was 30° warmer.

Before attempting an explanation of the peculiar architecture of the Terrace, it will be necessary to take into account the enormous amount of material removed from the hill in excavating the crater and cauldron; from careful measurements this cannot be estimated at less than $2\frac{1}{2}$ million cubic feet, an amount equal to a deposit of eight feet in thickness over the entire area of the Terrace. This detritus must either have been carried away with the overflow into the lake or deposited upon the hill-slopes.

Observing that the erosive action of the overflow was cutting a channel through the hard siliceous pavement of the upper platform, the torrent would certainly have opened a gorge through the soft rock, if in its initial form the Terata Geyser had exhibited similar characteristics to those with which we have been familiar.

Or had its earlier activity been more feeble and intermittent, the

overflow would have spread its surface-deposits over the face of the hill, as exhibited in the sinter formations of other hot springs in the district.

It also appears quite evident that the siliceous lining of the great cauldron could not have been deposited until the process of excavation was nearly complete, and that the solid precipitous walls, the comparatively level floor, and the perfectly level encircling rim must have acquired stability of form before the deposition of silica upon their surface.

The extension of the platform in front of the cauldron and the massive walls and basins which characterize the structure suggest to the careful observer the probability that their formation was due to the deposit, in a plastic condition; of the material thus removed from the crater.

The phenomena of mud volcanoes exhibited at the plateau of Rotokanapanapa afford to the geologist valuable indications of the probable appearance of the Terata cauldron in the earlier stages of its activity. This circular area, of similar size to the crater of the White Terrace, was situated in a hollow of the same hill, a few chains further towards the west, where the continued or intermittent action of steam escaping through felspathic tuff had gradually converted the rock into a perfectly level lake of mud and clay. The surface was covered with a semi-liquid layer from which rose a large number of miniature cones and craters varying in diameter from 2 to 20 feet, the former emitting steam, with occasional spats of mud, the latter bubbling and seething like boiling paste or porridge. Around the edge or outer rim of the area the mud was sufficiently compact to form a firm and safe footpath, while towards the centre it became very soft and hot.

Extending through a narrow outlet over the slope towards Rotomahana, the mud overflow preserved the same uniformity of level until it fell abruptly over a rounded breastwork which was encroaching upon the vegetation on the hill-side; the surplus water, thick and creamy at first, deposited its solid matter in hollows and upon obstructions, and finally escaped clear through the scrub to the lake.

If this condition had been succeeded by a gradual increase of thermal activity, it seems but reasonable to suppose that the softer clays around the centres of action would be slowly removed, to accumulate as masses of deposit upon the slopes below. Intermittent discharges of siliceous water would carry forward streams of plastic clay, which on meeting level ground would spread out and form sweeping curves of low elevation; this deposit would rapidly harden, as it dried upon the outer surface, into a cement like concrete; other following deposits resting upon those already laid would form a series of terraced steps. Succeeding streams of water penetrating through surface-cracks would excavate the still soft and plastic interior and redeposit the solid material thus removed, in the form of overhanging lips with pendent or stalactitic fringes, or as smaller intermediate steps, instances of which

can be observed at the white mud craters of Wairakei, near Taupo.

The comparative study of local phenomena thus appears to favour the theory that the initial activity of Terata was very similar to that of Rotokanapanapa, and that the successive periods which mark the history of the formation of the White Terrace correspond with the increasing activity of its source.

The hill surrounding Terata being pierced by numerous steam-jets, it is exceedingly probable that a large number around a common centre originally combined to form a crater-lake of seething mud. As activity increased, the outer wall of the crater would be occasionally broken down, and escaping mud-streams would be as frequently liberated. These periodical overflows would form by superimposition upon the hill-slopes the foundation of this curious and complex terraced series. The earlier streams moving slowly through the vegetation on the hill-side, spread out upon the level ground at the base, forming that beautiful series of curves previously described as the *Cold-water Basins*. The excavation of these basins would be easily effected, if, after the induration of their outer walls, *running water* penetrated through surface-cracks before the consolidation of their central mass.

The central steps, which rise immediately above these basins, appear to have been built up by the masses of plastic clay, which issued at successive periods as the wall of the crater yielded to the increasing activity.

The upper platform, with its massive circular outworks, would have been formed as the enlargement of the crater-gap increased to its historic dimensions, and the level surface, including that of the encircling rim, indicates a period when this entire area was in a soft and plastic condition.

As the eruptive force augmented, and as intermittent geyser-fountains succeeded, the smaller vents within the area would tend to unite in one enlarged vertical tube. The argillaceous contents, reduced to an exceedingly fine state of subdivision, would by prolonged boiling be removed and replaced by a siliceous cement, the more compact encircling rim being left entire around the cauldron.

The numerous tiers of shallow receptacles known as the *Upper Series*, hot-water basins, or 'cups' appear to owe their regular outlines to the successive waves of siliceous material which overflowed periodically during the excavation of the cauldron. Evaporation would cause this material to harden rapidly from its outer surface, and thus the lines of elevation would be maintained when the softer interior was removed by succeeding currents. Percolation of water through the pores would increase the deposit of silica within the interstices of the mass and further harden the basin-walls. Thus deposition and removal combined to produce that exquisite variety of form which characterized these horizontal lines of deposition.

The curious depressions upon the Upper Platform are also readily explained upon the hypothesis that the crust of the upper strata of

argillaceous deposit was broken through, and the softer parts of the interior removed.

Thermal activity within the cauldron having at length removed the softened rock, the deposition of siliceous incrustation in all its varied forms of elaborate crystalline ornamentation would decorate the foundations previously laid with that enchanting beauty which was the glory of the White Terrace.

Otukupuaranga, or the Pink Terrace, situated on the opposite side of Rotomahana, about a quarter of a mile further towards the west, had a frontage of 140 feet, and at a distance of 495 feet rose to the height of 85 feet. Of similar but older formation, and resembling the White Terrace in its essential features, it differed in many important details.

The colour from which its name was derived was characteristic only of the older deposits, which a new smooth white enamel was slowly obliterating. There were also numerous indications of diminution in the activity of its source, and of a probable change in the constituents of its overflow.

The structure may be considered in four divisions, corresponding to differences in the angle of inclination, viz. :—

1. The Front Plateau.
2. The Middle Terrace.
3. The Upper Platforms.
4. The Basin or Cauldron.

(1). The Front Plateau extended as a gentle slope 30 feet wide along the frontage, where it rose abruptly about 2 feet above the lake.

The overflow being confined to a central space 45 feet wide, the other portions were partially overgrown with moss and scrub, except at a narrow channel formed on the eastern margin.

(2). The Middle Terrace, or Terrace proper, consisted of sixteen well-defined tabular elevations averaging 4 feet in height, approached by numerous subordinate or intermediate steps, reduced on the margins to rippled and irregular cascades, which formed an easy ascent.

(3). The upper levels, a series of wide, smooth platforms, rising by slight elevations, extended completely across the Upper Terrace, a distance of 224 feet. Here were situated the "Baths," a series of eight hot-water basins, which were the only depressions on the Terrace.

The Baths were smooth shallow cavities, crescentic in outline, averaging 9 feet by 3 feet, with a depth of from 2 to 3 feet, ranging in temperature, according to distance from the Cauldron, from 90° to 130°.

The four principal bathing-pools were situated near the centre on rising grades, with an elevation of one foot, the massive fronts of the upper baths projecting considerably over the basin-area below.

(4). The Cauldron measured about 150 × 160 feet, and was

surrounded by a level rim, in width from 5 to 30 feet. The great basin appeared to be always full of deep-blue boiling water, edged with sulphur and enshrouded by a veil of steam. Usually overflowing without agitation, it was occasionally disturbed by wave-like upheavals. Its margin could only be approached at one part of its circumference, where soundings gave a depth of fifteen feet, and the wall just below the surface was seen set with spiny ridges.

Near the centre of the boiling lake was a dome or mass of spongy sinter, which could be seen only when the steam drifted away and the surface was unruffled.

By the terrible catastrophe of June 10, 1886, the waters of lakes Rotomakiriri and Rotomahana were drawn into the newly opened fissure, which had originated at the base of Ruawahia or Tarawera, and by the extraordinary explosions which succeeded, the terraces of Rotomahana were blown away, and wide steaming areas of desolation are all that remain to mark the site of these once world-renowned structures.

(For the DISCUSSION on this paper, see p. 188.)

14. *The ERUPTION of MOUNT TARAWERA.* By Captain F. W. HUTTON, F.G.S. (Read February 9, 1887.)

THE eruption of Mt. Tarawera, in the North Island of New Zealand, took place on the 10th of June, 1886. I was not able to leave Christchurch at once, but arrived at Rotorua on the 26th of June. During my stay in the district, which lasted till 14th of July, I examined Rotomahana and Okaro, and went across the Kaingaroa plains to Galatea. Subsequently, with Prof. F. D. Brown and Prof. A. P. Thomas, I visited Lakes Rotoiti and Rotoehu.

Description of the District.

About 25 miles south-west of Lake Taupo is Ruapehu (fig. 1), a truncated cone 9195 feet high, covered with perpetual snow. Until lately it was thought to be extinct, and is so described by Dr. von Hochstetter; but for several months past steam has occasionally been noticed issuing from the summit, and on the 16th of April last, Mr. L. Cutten, Surveyor, ascended the mountain and found the crater on the top to be 300 feet deep, with hot, eddying, and steaming water

Fig. 1.—*Sketch Map of the North Island of New Zealand, showing area affected by the Eruption of 10th June, 1886.* (Scale 200 miles to 1 inch.)

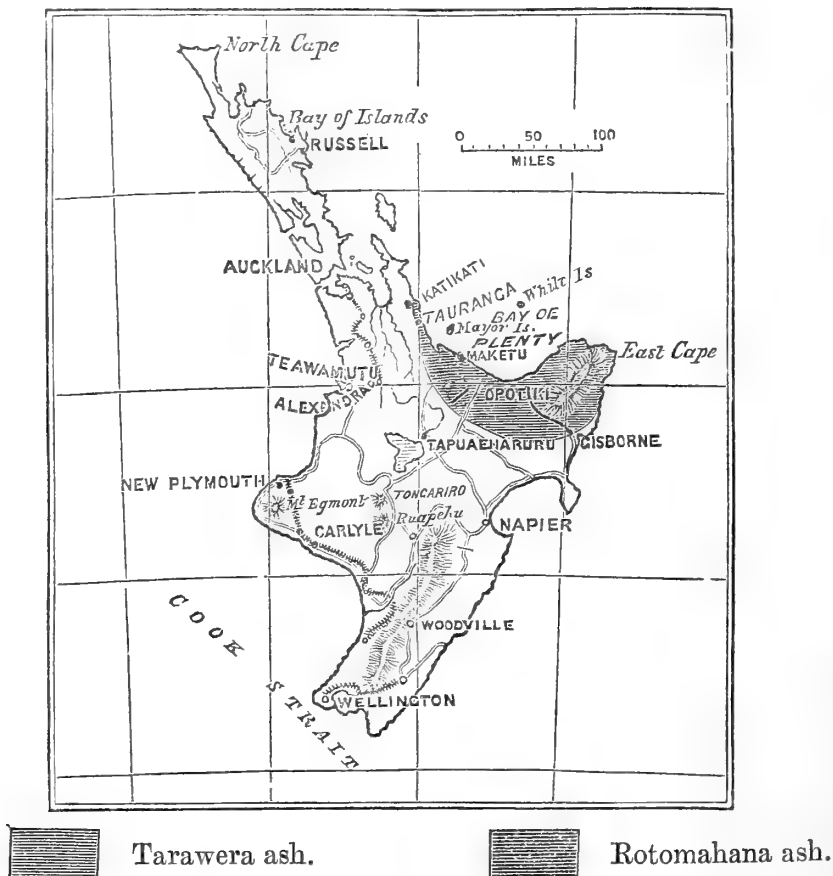

at the bottom, which had melted the snow all round for 40 feet, although about 100 feet above the water there was a fringe of ice.

The next day a large column of steam, 100 feet high, ascended from the crater. No earthquakes are recorded in the neighbourhood during the whole of this time. Between Ruapehu and Taupo lies Tongariro, the principal cone of which, Ngauruhöe, as well as two other smaller cones to the north, constantly emit steam. Ngauruhöe was in active eruption on July 6, 1870.

About 130 miles N.N.E. of Tongariro is White Island, or Waikari, in the Bay of Plenty (fig. 1). It is a solfatara, 860 feet high, and surrounded by water 1200 feet deep half a mile from its shore. Between them is a zone, 20 or 30 miles broad, abounding in solfataras, mud volcanoes, fumaroles, geysers, and hot springs, which has been called the Taupo zone by Dr. von Hochstetter. The scene of the recent eruption is in the centre of this zone, about halfway between Tongariro and White Island.

Mt. Tarawera stands on the eastern side of the lake of the same name. It is a flat-topped ridge about three miles long and nearly half a mile broad, surrounded by rocky precipices, rising abruptly from a plateau and sending out a long spur to the north-east, as well as a shorter one to the south. The highest point of the ridge is 3609 feet above the sea and is called Ruawahia; immediately to the north is a col, about 500 feet deep, which separates from the main part of the ridge a smaller and rather lower portion called Wahanga. The southern peak of the ridge, that which looks over Rotomahana, is called Tarawera by the Maories, but it is only one end of the ridge of which Ruawahia is the other, and Europeans generally apply the name Tarawera to the whole mountain, including Wahanga. It presented no appearance of being a recent volcano; there was no crater on the top, which seems to have undergone extensive denudation; and the Maories have no tradition of its ever having shown signs of activity.



Rotomahana was some two or three miles south of Tarawera (fig. 2). It was a shallow lake, about a mile long and a quarter of a mile broad, surrounded by numerous fumaroles and hot springs among which were the famous White and Pink Terraces. It drained into Lake Tarawera by the Kaiwaka stream. Its height above the sea is given by Hochstetter as 1088 feet. A little to the north-east of Rotomahana, under the spur from Mt. Tarawera, was a small lake called Rotomakiriri, on the shores of which were curious, circular crater-rings*. About two and a half miles south-west of Rotomahana is another small lake called Okaro; it lies immediately under Kakaramea, a pointed hill formed of fumarole clays (decomposed rhyolite) from the sides of which steam constantly escapes; but there were no hot springs in Okaro.

The rocks found in the district are all volcanic, chiefly rhyolite, which is generally the stony variety called liparite, but occasionally it is vitreous. South of Rotomahana, however, and probably on the southern slopes of Mt. Tarawera, a dark-coloured augite-andesite occurs. Near the hot springs the rocks are all decomposed into soft fumarole clays, white, red, yellow, and grey in colour.

* Hochstetter's 'New Zealand,' p. 419, and figure.

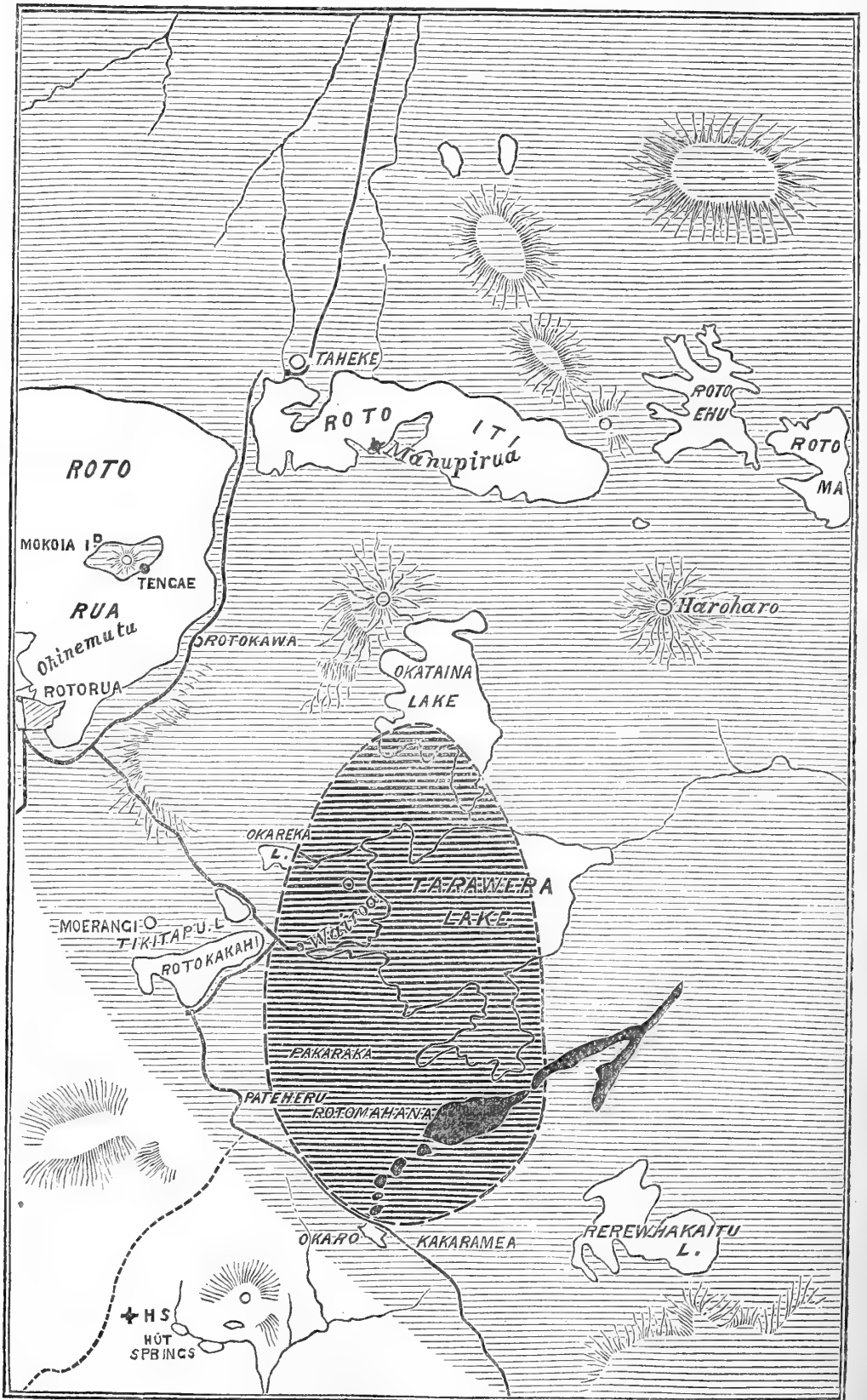
Fig. 2.—Map of the country around Tarawera Volcano after the Eruption of 10th June, 1886. (Scale 5 miles to 1 inch.)



	Places of activity.		Area covered by mud and ashes.		Thick mud-deposit.
---	---------------------	---	--------------------------------	--	--------------------

Account of the Eruption.

Earthquakes of a local character, but sometimes severe, have occasionally been felt in the Tarawera district ever since Europeans have inhabited the country; but during the last few months they had become much more frequent, not enough so, however, to excite alarm or even to arouse a suspicion that anything unusual was going to happen. Although Ruapehu had been seen to steam, Tongariro and White Island remained in their ordinary condition. The hot springs at the Rotorua had been gradually declining in volume and temperature; but this, as well as the low level of the lake, was no doubt due to the exceptionally dry season that had passed. At the end of May a wave, said to be a foot or eighteen inches high, crossed Lake Tarawera; it was unaccompanied by an earthquake, and to this day remains unaccounted for. On Monday, 7th of June, a party of excursionists from Wairoa visited Rotomahana accompanied by the well-known guide Sophia, and they reported nothing unusual there. Wednesday was fine at Rotorua, but showery at Wairoa, and the night was fine and calm everywhere.

At about 12.30 A.M. on the 10th, earthquakes commenced, slight at first, but gradually increasing in intensity, when at 1.15 A.M. Wahanga broke out with a vivid flash of light followed by loud explosions; only a small cloud was seen, which appears to have subsided and all was again quiet. At 1.45 A.M. the main eruption commenced with a roar from Ruawahia, and a black column, glowing with reflections from red-hot rocks below, shot upwards. At 2.10 A.M. a violent earthquake occurred, and Tarawera (proper) exploded with a deafening noise, sending up a broad steam-column. At 2.30 the whole mountain-top, from Tarawera to Wahanga, was apparently on fire, throwing out immense quantities of red-hot scoria. The steam-column, which was at first continuous all along the mountain, separated into seven or more distinct portions, and the huge black cloud spread slowly out from the top in the well-known mushroom shape. Forked lightning, blood-red in colour, flashed from the column, while the edges of the spreading cloud glittered and sparkled with innumerable electrical scintillations, making, together with the rocket-like showers of red-hot stones, a scene which is described as marvellous in the extreme.

At 2.30 A.M. another and quite distinct column of steam, a quarter of a mile in breadth, sprang from the ground far to the west of Mt. Tarawera. As seen from the hill behind Ohinemutu, on Lake Rotorua, this column went straight up to the west of the hill called Moerangi, and consequently it must have been in the direction of Kakaramea. In Wairoa also it was thought that Kakaramea had broken out; but it is now known that the most southern and western crater is two miles north of Kakaramea. This column of steam must therefore have come from what are known as the Okaro craters, between Rotomahana and Kakaramea. At 3.30 a series of violent earthquakes commenced, which lasted till 6 A.M. It was then that Rotomahana exploded, throwing out a column of

steam which out-topped that from Mt. Tarawera and obscured it. No shower of red-hot stones accompanied this explosion; the cloud appeared quite black except where relieved by lightning-flashes from the column and electrical coruscations round the margin.

The sounds now were frightful; even at Rotorua, 15 miles distant, it was necessary to shout as loud as possible in order to be heard two yards off. Mixed with the deafening roar of escaping steam were loud explosions from underground, and long rolls of thunder from above, as well as a hissing noise caused by the solid particles in the air rubbing together. So continuous were the lesser noises that, near the scene of eruption, the louder explosions were not noticed, although the earthquakes caused by these explosions are said to have occurred at Wairoa very regularly every ten minutes. But while the lesser noises were soon dissipated, the loud explosions travelled far, being heard at Auckland and even at Blenheim, 230 miles away. The red-hot stones ejected from Mt. Tarawera were distinctly seen at Gisborne, 75 miles off, and must therefore have risen more than 1500 feet above the top of the mountain. At Wairoa hot stones and scoria began to fall at about 2.30 A.M. At 3 A.M. icy-cold mud came down, the weight of which caused the roof of Mr. Hazard's house to give way at 3.40, and that of McRae's Hotel at 4.30. This mud fell until past 5 A.M., and was followed by fine, dry, flour-like ash, which continued until 9 A.M.

Meanwhile the black cloud swept away to the east and to the north. From 7 to 9 A.M. total darkness prevailed along the east coast from Tauranga to the East Cape, while ash continued to fall until the afternoon.

The crisis was over at 5.30 A.M., the most violent period lasting for three hours only; but the rapidity of the decline differed much in the craters on the mountain and those on the plain.

At 10 A.M. on the 10th of June, the eruption from the mountain was confined to the south end, or Tarawera proper, and this continued very active until midnight; but on the morning of the 11th all was quiet, small steam-jets only issuing along the ridge. The eruption from the mountain, therefore, lasted less than 24 hours.

The craters on the plain, at Rotomahana and Okaro, continued throwing up immense volumes of steam with some stones and mud, although with gradually diminishing force. On Sunday the 13th, the column of steam was calculated by Mr. Humphries, Surveyor, at New Plymouth to reach 22,000 feet above the top of the mountain and to be $1\frac{3}{4}$ or 2 miles broad; but this of course does not accurately measure the violence of the eruption. Sufficient energy continued in these craters to enable them to eject stones for about ten days, although most of them were thrown to small heights and fell back again into the craters. Since then they have slowly decreased, but large volumes of steam are still emitted from Rotomahana and can be seen for many miles around.

No steam was noticed from either Ruapehu or Tongariro on the morning of the 10th; but on the 12th and 13th Tongariro was steaming as usual. No change whatever appears to have occurred

at White Island during or after the eruption. The hot springs at Wairakei, near Taupo, are described as being in an extraordinary state of activity on the 10th; while during the eruption many new ones broke out at Ohinemutu, and the temperature of most of the old ones was raised. Also during the eruption the shore of Lake Rotorua, from Ohinemutu to Rotorua, sank several inches, this being probably due to the earthquakes causing a settlement of the land round the old springs.

The earthquakes which accompanied the eruption, although described as violent, did very little damage; but they appear to have been stronger in a south-west and north-east direction than towards the north-west. In Ateamuri on the Waikato, which is 28 miles from Tarawera, a tumbler was thrown from a box, and at Taupo, 38 miles distant, bottles were broken on a shelf. Nothing more violent than this seems to have taken place at Wairoa, only 5 or 6 miles off; while at Rotorua nothing was knocked down, and a brick chimney 20 feet high has sustained no damage whatever. No earthquakes were felt at Lichfield or at Oxford, although they were felt acutely at Tauranga and Maketu on the coast.

Results of the Eruption (see fig. 2).

The openings in the ground formed during the eruption have, as yet, been only hastily examined; and although Mt. Tarawera has been ascended and Rotomahana has been walked round, no accurate survey has been made, consequently our knowledge of what has happened is incomplete and must remain so until the summer. The following account is founded on my own observations round three sides of the mountain and on photographs which have been taken from many places, including the summit of Mt. Tarawera.

A large open fissure about four miles long and 500 feet broad runs along the top of the ridge from Wahanga to Ruawahia and then descends on the western side of Tarawera to the plain. Another fissure exists on the eastern side of Tarawera, but it is uncertain whether these fissures join. There is also a large crater on the southern end of Tarawera, probably connected with this second fissure. A comparison of photographs of the mountain, taken from Wairoa and from near Te Arika before and after the eruption, shows that there is no appreciable change in the outline of Wahanga; Tarawera Peak looks also much as it was before the eruption, but along the ridge between Tarawera and Ruawahia the accumulations from the fissure have slightly changed the outline, although no cone has been formed. These accumulations are said by Mr. Percy Smith's party, who ascended the mountain on the 28th July, to be about 100 feet in thickness.

Rotomahana is much enlarged and has now precipitous walls about 150 feet high, the whole of the sinter terraces having been blown away. The bottom is covered with mud, in which are several circular holes either emitting steam or filled with water. On the northern part there is a large crater-ring occupying the site

of Rotomakiriri and the White Terraces. Between it and Mt. Tarawera a new lake has been formed, with precipitous sides, about a mile in length and a quarter of a mile broad, but of irregular outline; whether this lake is connected with Rotomahana or not, I do not know. Between the northern end of the new lake and the southern end of the western fissure on Mt. Tarawera is another crateriform hollow, which is not connected with the lake or with the fissure. South of Rotomahana, in the valley of the Haumi, are the Okaro craters. There appear to be six or seven of them, situated on a line which curves round to the south towards Kakaramea. These are not connected by a fissure. They are flat-edged, more or less cylindrical holes, in which the surface rocks can often be seen, and none of them has thrown up a cone more than a few feet high. The first, or southern crater, is two miles from Kakaramea and has been estimated by Mr. Percy Smith at 250 yards long by 100 wide and 120 deep; the sides, however, are falling in, and it will soon become conical. The third crater, called the Black Crater, is divided into two by a narrow ridge of old rock which has been left; it is situated at the foot of a low hill, and when seen from a distance, in certain directions, this hill looks like a scoria cone. From this deceptive appearance it has been called Mt. Hazard; but the hill is part of the old surface, although of course covered, like the rest of the neighbourhood, by several feet of ash and stones.

Products of the Eruption.

The materials ejected are of two kinds, augite-andesite and rhyolite, and each is in both the compact and the vesicular state.

The *Augite-andesite*, when compact, is greyish black, vesicular in places, and with opaque, white, angular fragments of decomposed rhyolite or felsite. It is an andesite lava that has overflowed and included rhyolite; S. G.=2.67. The ground-mass is a brown glass with magnetite globulites, and it contains numerous felspar *laths* which show no fluxion-structure, except that they are arranged round the white rhyolite fragments parallel to their sides. One slide showed a quartz crystal broken across and faulted. In the vesicular state it is black scoria, very opaque; but in thin edges near the vesicles it is seen to be a yellowish-white glass full of glass-inclusions, globulites, and other impurities. It contains fragments of quartz as well as of rhyolite. I saw one broken crystal with aggregate polarization, probably partially decomposed hornblende.

The *Rhyolite* is of two kinds. The first is a pale-grey, stony rock with abundance of quartz grains, fragments of a white mineral like kaolinized felspar, and some pyrites. The ground-mass is opaque, but when very thin is seen to be crypto-crystalline, probably a devitrified glass. It contains abundance of quartz and fragments of decomposing sanidine with aggregate polarization in which occasional traces of Carlsbad twinning are recognizable. There is also a green mineral with aggregate polarization, probably hornblende, and magnetite or ilmenite. With reflected light the base is

white streaked with green. This decomposed rhyolite is a very common surface-rock in the district. The second kind is a soft, dead-white, fine-grained, compact rock, with minute black specks of hornblende or black mica, and crystals of pyrite, as well as occasional small grains of quartz. The ground-mass is a white glass, with innumerable small glass-inclusions, which are pale pinkish violet by transmitted light. It contains quartz, pyrites, and, rarely, sanidine not twinned. The vesicular state of these rocks is white glassy pumice with quartz grains more or less abundantly developed.

From the mountain came, chiefly, vesicular fragments of pumice and scoria, the latter in much larger quantities than the former. Many of the fragments, even those of small size, are composed partly of pumice and partly of scoria with well-defined junctions. The ash that accompanied these fragments is pale brownish grey, and contains much white and brown glass as well as quartz, sanidine, plagioclase, augite, and what appears to be a weakly pleochroic brown hornblende.

From the craters on the plains came angular fragments of compact rocks and lapilli, chiefly rhyolite, without any pumice or scoria. The ash that accompanied them is pale French-grey, and contains much devitrified glass and abundance of quartz with occasionally sanidine, plagioclase, and green augite.

The different ejectamenta are, of course, mixed together; but still a difference in distribution can be made out. That from the mountain spread to the south-west only as far as Kakaramea, but along the coast it extends from Katikati on the north, to Tolago Bay on the east. It is tolerably evenly spread, the heavier scoria at the bottom and the lighter ash at the top, and thins out very gradually. On the Kaingaroa plains, about ten miles south-east of Mt. Tarawera, the thickness of the deposit is five or six inches; while at the Southern Cross Petroleum Co.'s works, near the Waiapu River, between 89 and 90 miles distant, it is one inch thick, but, of course, much finer. This ash fell dry, and it was warm for a distance of eighteen miles from the mountain. The compact rocks from the craters on the plains were not thrown more than two or three miles, and the ash is much more limited in its distribution than that from the mountain. On the south-west it went to the base of Kakaramea; to the west it follows nearly the same line as that from Tarawera, while its easterly limit lies through the east end of Rotoiti to Maketu, but it gradually passes into the deposit from the mountain. Round the craters it fell hot and dry, but further off as intensely cold mud, almost freezing; and further off, again, it fell as dry dust. The mud seems to have fallen in pellets more or less rounded. I collected some of these out of the trees at Pakaraka, near Rotokakahi; they were of all sizes up to an inch in diameter, and some had a small piece of scoria in the centre. They must have formed in the air like rain-drops. One of them had a leaf halfway through it, which it had knocked off in its fall, proving that it was not frozen hard. On the morning when the mud fell there was a severe frost, and it fell so hard that it was

easy, even for horses, to walk over it ; but it soon got soft, owing probably to thawing. This mud deposit thins out very rapidly, the thickest portion forming an oval, from Lake Okaro to beyond Waitangi, ten or twelve miles long and five or six broad (see fig. 2). Beyond this to the north it thins out gradually, and it did not fall as mud much beyond Taheke. The following table shows this :—

	Distance from Rotomahana. miles.	Thickness of Deposit. inches.
Papawera Plateau	2½	39
Wairoa	5	30
Taheke	18	2½
Tauranga	43	1
Mayor Island	63	¼
Alderman Islands	90	⅛

These differences between the two deposits are due to the difference in the amount of water-vapour accompanying the different eruptions. The steam from the openings on the mountain was comparatively small in quantity and did not fall as rain, being dissipated in the atmosphere ; the ash was thus widely and evenly spread by the wind. The enormous volumes of steam which escaped from the craters on the plains condensed in the higher regions of the atmosphere into rain-drops, which, in their fall, brought down large quantities of ash that otherwise would have been carried further.

Round the craters the deposit varies from 10 to 50 feet, but appears to be very irregular ; for Prof. Thomas informs me that east of the new lake, at the foot of Tarawera, the Manuka (*Leptospermum*) is not covered, and the thickness is not much more than six inches.

At Wairoa there are two layers of scoria separated by several inches of mud, the lower of the layers resting on the ground, and the whole covered by about two feet of mud. These two scoria-layers no doubt mark two outbreaks from the mountain, probably when the two fissures were formed. The last outbreak must have taken place between 3 and 3.30 A.M., or just before the explosion of Rotomahana ; it seems therefore likely that the western fissure, which runs towards Rotomahana, was formed at that time, or about an hour and a quarter after the eastern fissure.

The ash began to fall at the Southern Cross Petroleum Co.'s Works near Waiapu, at 4.20 A.M., and at the East Cape at 5 A.M., at Rotoma and Rotoiti at 4 A.M., while it was not noticed at Tauranga until 5.30 A.M. ; so that it passed much more rapidly to the east than to the north. It ceased at Rotoiti at 10 A.M., and at Waiapu between 10 and 11 A.M. ; but along the coast of the Bay of Plenty it continued to fall until the afternoon. The correct time is, however, uncertain ; for, being dry, the wind blew it up in clouds. The night was generally calm, but at Waiapu a strong N.W. wind was blowing. At 3 A.M. at Wairoa a S.W. gale commenced, which, between 4 and 6 A.M., extended all over the eastern part of the

North Island as a southerly or south-westerly gale. The spread of the deposit seems therefore to be due to the ash from Mt. Tarawera having been thrown into an upper stratum of air where the wind was westerly, and this wind changed afterwards to the south. The eruption from the plains did not begin until later, and it was spread by the southerly wind only.

Cause of the Eruption.

The immediate cause of the eruption of Tarawera was, no doubt, the reheating of the old lava-streams of the mountain which were previously saturated with water. The proofs of this are:—

(1) A complete series can be made from compact andesite, with fragments of decomposed rhyolite, to the same rock highly vesicular but still showing fragments of the quartz of the rhyolite.

(2) A similar series can be made from decomposed rhyolite to quartzose pumice.

(3) The Black Crater threw out blocks of compact andesite-lava which had overflowed rhyolite, the two being intimately connected at the line of junction, but not passing one into the other. A similar intimate connexion of scoria and pumice is seen in fragments ejected from Mt. Tarawera; and it is hardly possible that the same intimate connexion between two similar rocks could have been brought about in two different ways.

(4) It follows, therefore, that the scoria and pumice are remelted andesite and rhyolite lava-streams. However, some of the scoria may have had a deep-seated origin, as it does not always contain pumice.

This reheating must have taken place locally in the mountain and not very far from the surface, as the reheated rocks have undergone atmospheric decomposition. It could not, I think, have been due to crushing, because (1) the earthquakes preceding the eruption were not violent, many people both at Wairoa and Rotoma not being awakened until after the eruption had commenced. And (2) as several millions of tons of rock have been fused and ejected, it follows, according to the Rev. O. Fisher*, that several tens of millions of tons must have been crushed and not fused. This unfused rock was certainly not ejected with the fused, and the open fissure on the top of the mountain shows solid rock on each side. There is therefore no evidence of this enormous quantity of crushed but unfused rock, and for other well-known reasons its existence is highly improbable.

The only possible hypothesis seems to be that molten rock came up from below into the mountain and heated the surface-rocks; and this is rendered more probable by the fact that Ruapehu has also been lately heated up without any earthquakes having been felt. The cause of the ascent of the molten rock, whether by occluded vapour or by pressure caused by movement of the earth's

* 'Physics of the Earth's Crust,' p. 230.

crust, need not be here considered; for I do not see that the present eruption throws any new light on the question.

The eruptions that took place on the plains were only hydrothermal in character, no great heat being developed. They followed the eruption of the mountain and were, no doubt, caused by the earthquakes. Their position shows that they are in some way connected with the fissure on the mountain, but they cannot be directly connected with it; for, if that had been the case, they would have ejected scoria like the mountain, and the explosion of Rotomahana would probably have preceded that of the Okaro craters. Probably molten rock was injected, as a dyke, into the fissure below the surface, and the earthquakes caused the surface-water to approach this dyke sufficiently close to be heated and flashed into steam. These explosions, therefore, furnish evidence that water cannot find its way to molten rock by means of open fissures.

DISCUSSION.

The PRESIDENT spoke of the value of the descriptive portions of Mr. Martin's paper. He had enjoyed great opportunities of observation, and the series of photographs sent over by him was of extreme interest. As regards the theoretical portion of the paper, there was room for some difference of opinion. Mr. Martin had, however, based his theory on the study of similar structures in different stages of growth.

Referring to Capt. Hutton's paper, he said that the New-Zealand geologists had shown great energy in studying the eruption. Dr. Hector started at once; some of his photographs, taken at an early stage of the eruption, along with maps and specimens, were on the table. Captain Hutton came somewhat later, and among his discoveries were the augite-andesites which were found associated with the prevailing rhyolites. He was rather disposed to regard the latter as quartz-dacites. He referred to the differences of opinion as to the origin of the eruption.

Prof. SEELEY regretted that Mr. Palmer, who was on the spot at the time of the eruption, and whose travelling companion was killed under a crushed roof, could not be present. His views were slightly different from those of Capt. Hutton; there was no eruption seen of scoriæ and stones, nothing but grey volcanic ash and fine mud covering the country. At the earliest moment possible after the eruption Mr. Palmer reached Rotomahana, which was empty, but boiling and spouting at the bottom. He considered that the Terraces had probably been blown away, but that their sites were covered up by mud and hidden by steam. The water of the lake had gone to furnish some of the steam which had issued from Tarawera. There was no evidence of the outburst being a true volcanic eruption.

The PRESIDENT considered that Mr. Palmer might not have been in the best possible position for ascertaining the effect of the eruption. In fact there were two eruptions; of the one from the mountain the scoriæ are sent by Capt. Hutton. Those first on the spot

would see nothing of these, as they were covered up by the finer ejection. Dr. Hector considered that the stones thrown out were hot but not molten. There can be no doubt that the sites of the Terraces are gone, for Dr. Hector says that fragments of sinter are abundant in the materials ejected from Rotomahana, and this is confirmed by the microscope. Capt. Hutton contested the purely hydrothermal nature of the eruptions from the mountains.

15. EVIDENCE of GLACIAL ACTION in the CARBONIFEROUS and HAWKESBURY SERIES, NEW SOUTH WALES. By T. W. EDG-WORTH DAVID, Esq., F.G.S. (Read February 9, 1887.)

INTRODUCTORY.

THE series of rocks in New South Wales which are coal-bearing, or intimately connected with the coal-bearing division, and are referable to the Mesozoic and Palæozoic eras, have been classed provisionally by the Government Geologist, Mr. C. S. Wilkinson, F.G.S., F.L.S., &c., as follows:—

Mesozoic.	Triassic.	9. Wianamatta series.	{ Fresh water. 700 feet thick.
		8. Hawkesbury series.	{ Fresh water. 800 to 1000 feet thick.
	Passage beds.	7. Clarence series, including the Narrabeen series.	{ Fresh water.
Palæozoic.	Permian.	6. Newcastle series	= { Upper coal-measures. Fresh water.
		5. East Maitland series	= { Middle coal-measures. Fresh water.
	Carboniferous.	4. Upper Marine series	= Branxton series.
		3. Greta series	= { Lower Coal-measures. Fresh water.
		2. Lower Marine series.	
	1. <i>Lepidodendron</i> -series	= Fresh water.	

Evidence of ice-action has been observed in the Carboniferous Marine series (No. 4), and phenomena which appear to be referable to a similar agency in the Hawkesbury series (No. 8).

I. CARBONIFEROUS GLACIAL BEDS.

References by previous observers to Glacial Beds of Carboniferous age in Australia.

The first description of boulder-beds in New South Wales, so far as I am aware, is that given by the late Dr. T. Oldham*, quoted by R. D. Oldham in the 'Records of the Geological Survey of India,' vol. xix. part i. 1886, p. 43. With reference to the Carboniferous marine beds at Wollongong, Dr. Oldham says:—"And still further, many of the lower beds of the Australian group, there so abundantly rich in marine fossils, are very similar to many of the beds in the Indian Talchir series. There is the same mixture of pebbles and

* Mem. Geol. Surv. India, vol. iii. p. 209.

large rolled masses in a matrix of fine silt; and much of this silt is of exactly the same peculiar bluish-green tint so characteristic of these beds in this country, and which when once seen can never be mistaken," &c.

Dr. Oldham, however, does not suggest a glacial origin for this formation. The next account of Carboniferous (?) Boulder-beds is that given by the late Sir R. Daintree in his 'Report on the Geology of the District of Ballan,' Melbourne, 1866, page 10, where he describes part of the Bacchus-Marsh beds in Victoria as:—"Strata mainly composed of fine mud, dotted throughout with various-sized, generally rounded, pebbles, and those pebbles mostly unknown in the vicinity, and some not yet seen in place as far as the Geological Survey has extended a minute examination." Some of the granite boulders are stated to be over a ton in weight, and to be imbedded in soft mud.

The first suggestion of the possibility of ice having played some part in the formation of these rocks was made in the same Report by Sir R. Daintree; and his views therein expressed are upheld by Dr. A. R. C. Selwyn, F.R.S. &c., then Director of the Geological Survey in Victoria, in "Notes on the Physical Geography, Geology, and Mineralogy of Victoria," published at Melbourne in the Official Catalogue of the Intercolonial Exhibition, 1866-1867, page 16. The passage reads as follows:—"The character of the conglomerate beds before mentioned near Darley and on the Wild Duck Creek is such as almost to preclude the supposition of their being due to purely aqueous transport and deposition. It is, however, very suggestive of the results likely to be produced by marine glacial transport; and the mixture of coarse and fine, angular and water-worn, material, much of which has clearly been derived from distant sources, would also favour this supposition. Grooved or ice-scratched pebbles or rock fragments have, however, not yet been observed."

The next mention of ice-action in Carboniferous rocks in Australia is made by Mr. R. L. Jack, F.G.S., Government Geologist of Queensland, in his Report on the Bowen-river Coalfield, dated November 23, 1878 (printed in Brisbane, 1879), page 7. In the middle (marine) series he describes conglomerate beds, chiefly occurring in the lower part of the series, as follows:—"The included pebbles are generally of granite, slate, schist, quartzite, and other metamorphic rocks, with a few of porphyrite. The pebbles, which are not always well rounded, have a remarkable tendency to arrange themselves in groups in some of the conglomeratic sandstone beds—a disposition which may possibly be owing to their having been dropped in heaps from the floating roots of trees, but much more likely from floating ground-ice. Large isolated boulders of granite &c. occur here and there in the midst of strata of fine sandy or muddy material. These could hardly have been brought to their present positions except by glacial action."

The marine fossils associated with these beds prove them to be homotaxial with the Wollongong beds described by Dr. Oldham, and of true Carboniferous age. But it is doubtful whether they can

be correlated with the Bacchus-Marsh glacial beds, the only fossil found in the latter being *Gangamopteris*, a plant of doubtful geological horizon.

In 1884 Mr. C. S. Wilkinson examined the Upper Marine Coal-measures (No. 4 in the table) in the neighbourhood of Branxton, near Maitland, and observed in the road-cutting west of the railway station a very coarse conglomerate containing large subangular boulders of clay-slate and other rocks foreign to the district, which he considered to be erratics; no ice-scratches, however, were at that time noticed.

It was reserved for Mr. R. D. Oldham, A.R.S.M., Deputy Superintendent of the Geological Survey of India, on a visit to the Colony in 1885, to make the important discovery of the presence of boulders and pebbles, unmistakably striated and polished by ice, in a railway-cutting at Branxton, close to the spot where the erratics were first found by Mr. Wilkinson. Mr. Oldham has described these beds in the 'Records of the Geological Survey of India,' vol. xix. part i. 1886, page 44. The marine fauna associated with this formation shows it to be homotaxial with the Bowen-river and Wollongong beds.

Carboniferous Glacial Beds at Grass-tree.

Since this discovery by Mr. Oldham, the author, when commencing a survey of the Northern Coal-field of New South Wales in 1886, found another extensive glacial deposit, probably of the same age, at Grass-tree, near Musclebrook, 28 miles north-westerly from Branxton. A fine section of the Carboniferous glacial beds is exposed here in the railway-cutting, showing them to extend for at least a mile horizontally, and to have a thickness of not less than 30 feet.

The deposit here consists of reddish-brown to greenish-brown shales, and is crowded with round and subangular fragments of rock, from pebbles no larger than marbles up to blocks $\frac{1}{3}$ ton in weight.

The matrix in which the boulders are imbedded is a fine calcareous sandy shale, reddish to rusty brown near the surface, and passing at a depth of 15 feet first into a pale greenish brown, then into a leaden grey. At intervals of from 3 to 20 yards spherical concretions from $\frac{1}{2}$ to 2 feet in diameter, as round as cannon-balls, occur in the shale. When broken open these are found to be composed of a nucleus of carbonate of lime surrounded by a shell of shale partly cemented by calcareous matter.

From the surface downwards, for about 15 feet, there is an appearance in the shale suggestive of bedding, but due probably to the formation of ferruginous bands in the shale through the percolation of surface-water carrying iron in solution. Lenticular patches of gravel may be observed in places filling contemporaneously eroded hollows; but stratification, if it exists, is not strongly marked.

Most of the boulders in the beds are more or less rounded, angular fragments being rare. Their shape is very irregular, but generally one end is more pointed than the other, and as a rule their outlines are less convex than those of water-worn pebbles.

Most of the stones presented the appearance of having been ground, and showed a dull polish, and many exhibit well-marked striæ. The proportion of the boulders possessing the requisite grain, hardness, and durability to receive and preserve delicate ice-scratches was small as compared with the number unfitted for such purpose. Those which are most decidedly striated are dark clay-stones, fine-grained quartzites, and slates. These are scratched on the top, bottom, and sides. The striæ, although plainly visible, are not deeply cut, and no grooves were observed. Most of the boulders are partially covered with a thin crust of carbonate of lime, the derivation of which is obvious from the calcareous nature of the shales. The largest specimen of the glaciated blocks exhibited was found by the author firmly bedded in shale at a depth of 15 feet from the surface. The other specimens were also obtained in position. The largest boulders are those of clay-slate, granite, and aplite.

The following is a list of the different varieties of rocks observed to occur as boulders in the shale:—quartz and felspar-porphyry; clay-slate; dark felspar-porphyry or porphyrite; quartz-felsite, frequently showing fluxion-structure; quartzite, reddish brown, greenish brown, and dark blue with iron pyrites; quartz; black quartz (?); coarsely crystalline quartz and felspar-porphyry; felsite; diorite (?); claystone; shale; felspathic quartzite; granite; aplite; gneissic granite; chloritic quartz-porphyry; decomposed vesicular trap and hornblende-schist.

The nearest parent rock from which some of the boulders could have been derived is about 30 miles distant.

The largest boulder measures 3 feet \times 1 foot 4 inches \times 7 inches. The beds have such a fresh appearance that when viewed from a short distance they might easily be mistaken for Pleistocene moraines. No evidence as to their total depth could be obtained at Grass-tree. At Branxton, however, Mr. Wilkinson roughly estimates their thickness at not less than 1000 feet.

Fossils were not found by the author in the Grass-tree beds, but there is stratigraphical evidence for correlating them, provisionally, with those at Branxton.

At present, all that can be truly stated is that, at Branxton, glacial beds exist of undoubted Carboniferous age, and similar beds, presumably of the same age, at Grass-tree. The coarse marine conglomerates of the lower Coal-measures, near Wallerawang in the western coal-field, containing large smooth blocks of Devonian quartzite, are believed by Mr. Wilkinson to be also partly of glacial origin.

II. PROBABLE ICE-ACTION IN THE TRIASSIC HAWKESBURY SERIES.

Two phenomena observed in the rocks of the Hawkesbury series appear to indicate that ice was present, to a certain extent, during their deposition.

These are:—

1. Disrupted angular fragments of shale.
2. Contemporaneously contorted current-bedding.

Section of Contorted Strata overlain by Current-bedded Deposits, at Coogee Bay, near Sydney, N.S.W.



1. *Disrupted Angular Fragments of Shale.*

The first mention of evidence of ice-action in New South Wales was made by Mr. Wilkinson, in connexion with certain appearances in the shale beds interstratified with the sandstones of the Hawkesbury series, in a paper read before the Royal Society of New South Wales, December 4, 1879 (see Transactions of the Royal Society of New South Wales, vol. xiii. p. 106, 1880.)

He makes the following statement:—“In the sections exposed in the quarries at Fort Macquarie, Woolloomooloo, Flagstaff Hill, and other places, may be seen angular boulders of the shale of all sizes up to 20 feet in diameter, embedded in the sandstone in a most confused manner, some of them standing on end as regards their stratification, and others inclined at all angles. They contain the same fossil plants that are found in the beds of shale from which they have evidently been derived. These angular boulders occur nearly always immediately above the shale beds, and are mixed with very rounded pebbles of quartz; they are sometimes slightly curved as though they had been bent whilst in a semi-plastic condition, and the shale beds occasionally terminate abruptly, as though broken off. Had the boulders of soft shale been deposited in their present position by running water alone, their form would have been rounded instead of angular. It would appear that the shale beds must have been partly disturbed by some such agency as that of moving ice, the displaced fragments of shale becoming commingled with the sand and rolled pebbles carried along by the cur-

rents. . . . These boulder accumulations occur in irregular patches apparently throughout the Hawkesbury series."

This series is fresh water or estuarine, classed on stratigraphical and palæophytological grounds as Triassic, and cannot therefore be correlated with the Wollongong or Bowen-river series.

2. *Contemporaneously contorted Current-bedding.*

The author is not aware that any description has yet been published of this remarkable structure, so frequently seen in the current-bedded sandstones of this series. The nature of this structure is shown on the accompanying figure (p. 194). That the crumpling of the beds was contemporaneous is evident from the undisturbed character of the overlying current-bedded sandstones.

The contortions have evidently been caused by some extensive lateral thrust, such as would be produced by the grounding of floating ice; but more extended observation will be necessary ere this can be demonstrated.

NOTE.

Ice-action in Siluro-Devonian beds in New South Wales.

Two miles north of the town of Temora, Mr. Wilkinson reports the occurrence of gold-bearing conglomerates, which he believes are of Siluro-Devonian age. The boulders are much rounded, polished, and in some cases striated. The blocks consist chiefly of quartz imbedded in a clayey base; the largest have a diameter of 4 feet.

DISCUSSION.

Mr. CRUTTWELL dissented from Mr. David's classification of the Australian Coal-beds. He thought the Wianamatta and Hawkesbury beds equal the Mymyddylwyn and Pennant beds (Upper Carboniferous) of South Wales. He considered the appearance of glacial action due to agencies still prevalent in Australia, such as the effect of melting snow and floods in the higher Cordillera.

Prof. BOYD DAWKINS considered the evidence required further inquiry. Striated pebbles were not alone sufficient evidence of glacial action, they might be produced by earth-movements after the consolidation of rocks. The speaker could see nothing distinctly glacial in the specimens exhibited.

He also sympathized with the doubts expressed by the last speaker as to the classification of the rocks adopted by Mr. David. He could detect no break in the sequence, and he had found *Glossopteris* to the west along with Lepidodendroid plants of Mount Victoria.

One of the specimens on the table was from Old Red Conglomerate, striated by earth-movements. He asked for information about the Punjab specimens exhibited. They had a singularly artificial appearance.

Mr. GOODCHILD said the stone from the Upper Old Red was from

Cumberland, and was an example of striation produced after the rock had been consolidated.

Dr. BLANFORD gave an account of the boulder from the Punjab Olive Bed on the table, and pointed out that the occurrence of large blocks in fine shales had been first noticed, and this observation had, in both India and Australia, been followed by the discovery of striated surfaces.

The marine beds described by Mr. R. Oldham could not have been formed by floods or violent water-action, for the shales containing the boulders held imbedded delicate bivalves, with both valves united, and fine *Fenestellæ*; the boulders must have been transported by a different agency from the fine sediment.

Prof. SEELEY admitted the difficulty of judging the fragments exhibited without seeing the sections. He could see no evidence of glacial action in the specimens exhibited, and thought that similar partly angular blocks might be gathered on any coast where the cliffs were formed of rocks of like character. He had never seen a glaciated fragment similar to that exhibited from the Punjab. The unworn edges of the facets could scarcely have remained uneroded if produced by glacial action. They had no resemblance to wind-worn faces.

Rev. E. HILL said the Punjab boulder might have shifted its position in the bottom of a glacier. However, ice does not necessarily imply a glacial age.

Mr. RUTLEY agreed with the last speaker that the stone in question might have been faceted and scored by the action of ice.

The PRESIDENT regretted the absence of Mr. David, but called attention to the photographs sent by him as illustrating the nature of the beds in which the blocks occur.

16. *Further* NOTES on the RESULTS of some DEEP BORINGS in KENT.
By WILLIAM WHITAKER, B.A., F.G.S., Assoc. Inst. C.E. (Read
January 12, 1887.)

[The fresh information given in this paper is communicated by permission of
the Director General of the Geological Survey.]

CONTENTS.

Introductory Remarks.
The Chattenden Boring.
The Dover Convict-Prison Boring.
New Boring at Strood.
Boring at Lydd.

INTRODUCTORY REMARKS.

THE primary object of my paper read to the Society in 1886* was to describe the boring at Chatham, which had reached Oxford Clay; but the paper was extended, to include other borings in Kent which had passed through the Chalk, and had not been brought to the notice of geologists.

Since then further and fuller information has come to hand with regard to two of these borings, and another deep work has been carried through the Chalk and the Gault into the Lower Greensand.

I have thought it well therefore to send this supplementary paper to the Society, especially as one of the borings, at Dover, has now thrown fresh light on that important and interesting subject, the underground geology of the London Basin. It was originally meant to incorporate these notes with others descriptive of deep borings in Surrey; but as those borings are not yet finished, and as there is a special interest in the Dover boring, it seems better to let the Surrey borings stand over, and to place the new Kentish information in the hands of the Society at once.

With regard to the doubt as to the depth of the second Chatham boring, expressed on p. 30, it should be noted that whilst this depth is rightly made 965 feet *from the surface*, yet it is only 963½ from the point from which the measurements were made, the coping-level being 18 inches below the surface. 20½ feet therefore would seem to be the right thickness of Oxford Clay pierced.

* Quart. Journ. Geol. Soc. vol. xlii. pp. 26-48, pl. iii. Four errors in this paper have been noticed on the wrapper of the May No. of the Society's Journal (1886); but they may be repeated here with three others:—

P. 29, line 8 from foot, *for* 450 *read* 45.

P. 30, lines 9, 10 from foot, *for* "below the 450 feet that was dug," *read* "below 450 feet."

P. 35, line 5 from foot, *for* "180" *read* "280."

P. 47, line 15, *for* "third" *read* "half."

P. 47, line 16, *for* "2640" *read* "1760;" and *for* "double" *read* "treble."

Pl. iii. heading, *for* "S.S.E." *read* "S.S.W."

THE CHATTENDEN BORING.

Since the publication of my paper the boring at the Chattenden Barracks, northward of Chatham, has been successfully finished. I ventured to say that some 60 feet more (than the 1103 already sunk through) should reach the bottom of the Gault, but that desirable result happened in only 59 feet. I did not, however, predict the finding of Lower Greensand here, seeing that there was so little thereof further south at Chatham; but Lower Greensand has been found, and has yielded the wished for water.

Having visited the site, seen some specimens, and got further details from Capt. W. W. Robinson, R.E., who had charge of the work, and who has described its progress*, I am now enabled to amplify the last two lines of the former account, as below.

Chattenden Boring. Details below the Tertiary Beds.

	Thickness in feet.	Depth in feet.
Tertiary beds (as before).....	290	290
Chalk. Specimens of clayey chalk (probably Chalk Marl) at 890, 905, 920, and 940 feet. No springs found. Base not noted. Presumable thickness, judging by the Chatham sections, say	680 or 682	972?
Gault, with some pyrites. Specimens, light-coloured clay at 1100 and 1130, the latter with <i>Inoceramus</i> ; just above 1140 a <i>Rostellaria</i> ; at 1140 a phosphatic nodule, with the cast of the whorls of an <i>Ammonite</i> ; about 1140 a small phosphatic nodule, chiefly an <i>Ammonite</i> ; at 1142 dark grey clay. For the last few feet the clay was dark, but with green grains. About 9 inches of rock at the bottom (specimen of phosphatic nodule, from 1161 feet)..... ? about	192 or 190	1162
The chisel then dropped 3 feet, and water quickly rose to about 107 feet below the surface, some greenish sand being brought up in the first ebullition. Presumably therefore the Lower Greensand was touched. Sand rose about 60 feet up the tube, and a specimen of the earth being removed (in February 1886) consisted of a mixture of Gault clay with some green sand.		

When the bottom of the tube was cleared out, and the tubes were driven down into the sand, the water rose to within 100 feet of the surface.

The almost exact correspondence of the total thickness of the Chalk and the Gault, 872 feet, with the same total at Chatham, where well no. 1 gives the figures 878, and well no. 2 the figures 875, is noteworthy.

The presence of the Lower Greensand here shows that in my section (Quart. Journ. Geol. Soc. vol. xlii. pl. iii.), that formation should have been carried a little further north.

* 'The Royal Engineers' Journal,' vol. xvi. no. 188, pp. 151, 152 (July 1, 1886).

THE DOVER CONVICT-PRISON BORING.

Since the reading of my paper the Dover boring has been carried a few feet deeper, and has been abandoned from want of success in finding water. I have visited the site, in company with Major Beamish, R.E., who had charge of the prison-works, and secured a number of good specimens of the bottom-clays.

The few small specimens previously to hand seemed of rather doubtful character, partly by reason of the attempted personation therein of fossils. The abundant material since to hand, however, disposes of any doubt as to the *bonâ fide* character of the earlier specimens, which is satisfactory.

The new specimens themselves may hardly have been thought satisfactory by my colleagues, Mr. G. Sharman and Mr. E. T. Newton, who carefully examined them; for, after washing and sifting pieces of many of these, they arrived at a negative result. They could find no sign of fossils, save for a solitary specimen of a *Rotalia*. Whether this was really in place in the bottom-clays, or had been carried down into them by the boring-tool, is a question not worth debating.

As we can get no information from fossils, we must turn to the oft-abused lithological character of the specimens for guidance, and in this case, I think, with some result. Before taking up this subject, however, some corrections may be made in the classification of the beds in my former paper.

In the first place, there can be little doubt that the three beds, of a total thickness of five feet, doubtfully classed as the top of the Lower Greensand are really the clayey greensand and nodule-bed that form the base of the Gault.

In the second place, the lowest bed bracketed with the Lower Greensand, though with doubt, is shown by specimens to belong instead to the underlying series.

The taking away of these 18 feet of beds from the Lower Greensand leaves that formation with a thickness of 31 feet only, and it will be of some interest to make out what divisions of that formation are present. At the outcrop, some miles to the S.W., we have four divisions:—the Atherfield Clay, at the bottom, nearly 50 feet thick, much in excess of the usual thickness in Kent; the Hythe Beds, about 60 feet; the Sandgate Beds, here reaching a thickness of about 80 feet, though usually much less; and the Folkestone Beds, 90 feet thick, at the top.

Beginning with the lowest of these, here, as at Chatham, there is no sign of the marine Atherfield Clay. The two borings also agree in the absence of anything like the sandy calcareous mass of the Hythe Beds. When examining specimens from the lower part of the Dover Lower Greensand, it struck me that I had seen something of the same sort amongst the Chatham specimens, and on turning to these it was found that the two sets exactly agreed in character, as far as regards the bottom eleven feet or so; for, on putting the specimens side by side, it was impossible in some cases to see the

slightest difference between them, and in no case was there any notable distinction. We may fairly conclude therefore that this part of the Dover section should be classed with the Sandgate Beds, as was done in the Chatham case.

Whilst at Chatham, however, these compact clayey sands are overlain by looser sand, like that of the Folkestone Beds, at Dover the upward continuation of the Lower Greensand is still in clayey sands, though differing in colour from those alluded to above, and there seems to be nothing representative of the sandy Folkestone Beds. It seems fair therefore to conclude that we have here the Sandgate Beds alone, especially as these are thicker at the neighbouring outcrop than to the west, although that division of the Lower Greensand is the most inconstant of all along the outcrop in Kent, as well as in Surrey.

Returning to the beds below the Lower Greensand, a little mistake in the published account should be put right. A very small specimen of one of the clays is described as "mixed with chalky matter." It contained some white specks, which, from their appearance, were taken to be calcareous. When the larger and better set of specimens was examined, this was found to be a wrong inference; for the peculiar white earth, of which there was plenty, gave no sign of effervescence when dilute hydrochloric acid was poured on it: the acid simply soaked in.

On a like test being applied to various Cretaceous and Jurassic marine clays a very different result followed: as would be expected, they all gave clear signs of containing calcareous matter.

In view therefore of the possibility of these clayey beds being of Wealden age, a possibility which had been already alluded to, it was desirable to examine specimens of Wealden clays. Unluckily our rock-collection at Jermyn Street was very poor in this particular, and it was not until after some time that I was able to make the needful examination.

It having occurred to me that Mr. G. Maw was likely to have a good collection of clays, I applied to him, and he was kind enough to send me twenty-two specimens from Wealden beds. These may be divided into three sets.

Firstly, three specimens of Weald clay. One of these was from a *Paludina*-bed, another was from a bed that rested on the Horsham Stone, and the third came from between layers of that stone. Under these circumstances it is not surprising that, in all, effervescence ensued on the application of hydrochloric acid.

Secondly, eight specimens of Wealden clays from Dorsetshire, none of which caused effervescence. As, however, these were not like our Dover clays, we may pass them by.

Thirdly, ten specimens from the Ashdown Series, at and near Hastings. These showed various points of likeness to the bottom beds of the Dover boring: none of them caused effervescence with hydrochloric acid; some of them had the same whitish colour and the same very fine texture; altogether they reminded one of the Dover specimens, and I feel no doubt that the beds there reached

belong to the Hastings Beds. To say that they belong to the Ash-down Series, the lowest division of these, might be rash, as like beds occur more or less throughout; but at any rate there is a great probability that they may do so.

With the fresh information acquired both from specimens and from notes, for which, in both cases, I have to thank Mr. R. D. Batchelor, the well-sinker, I am enabled to give the following much fuller account of the beds below the Chalk in this important section:—

	Thickness in feet.	Depth in feet.	
To base of Chalk. Specimen of clayey chalk at 630 feet	675	
Gault, 143 feet. {	Gault. Specimens, grey sandy clay at 721; grey sandy clay with green grains at 800 (both calcareous); light-greenish sandy clay or clayey sand at 813; phosphatic nodules, depth not marked. At the site there is plenty of the ordinary dark grey clay, sometimes with green grains, and phosphatic nodules	138	813
	Rocky dead green sand	1	814
	Dead green sand	2	816
	Hard boulder-rock (? nodules)	2	818
	Dead green sand. Specimens, green clayey sand at 822; very fine-grained greenish clayey sand at 826; fine greenish-grey clayey sand, or sandy clay, at 831; a set of fine-grained grey or brownish-grey sandy clays or clayey sands, at 838, 840, 841, 844, 845, 847, and 848, compact and <i>exactly like the specimens from the Chatham boring</i> (932 to 943 feet)	31	849
Lower Green-sand. The lower part (and probably the whole) Sandgate Beds. {	Black sand and clay. Specimens, brownish-grey clay, rather sandy, at 856 and 858; brownish and grey clay at 862	13	862
	Brown Clay. Specimens, brownish-grey, rather sandy clay at 864; grey and brown clay, with specks of pale very fine sand; brown and brownish-grey clay at 875; grey clay, with pale very fine sandy specks (<i>not</i> chalky, as was thought from the small specimens first seen)	17	879
	Dark sand and clay. Specimens, brown and grey clay, one slightly sandy, the other with pale specks (as above) ...	1½	880½
	Rock. All broken up, no specimen got. [Below this the account differs from that published before.].....	½	881
	Light-brown clay. Specimens, brown and grey clay at 882; brown clay at 884; grey clay at 885; grey and brown clay at 886; brown clay, and grey clay with specks of pale fine sand, at 888; grey clay at 890 (rather sandy) and 893	13	894
Wealden. Probably Hastings Beds, 82 feet. {			

	Thickness in feet.	Depth in feet.
Wealden (continued).	Dark clay with pyrites. Specimens, grey clay at 895 and 898	4 898
	Hard dark clay. Specimens, grey clay at 899, 900, 901, and 933, some with pale sandy specks	7 905
	Brown clay. Specimens, grey clay at 906; pale grey pipe-clay, with pale very fine-grained sandy lumps, the whole whitish and calcareous in appearance, but not so really	6 911
	Dark clay, with rag-boulders. (? Some error here, specimen at 913 being of whitish earth, like the last; ? former account more correct.) Specimens, grey clay, with light-coloured patches, at 915; grey clay at 917 (one piece sandy) and 918	14 925
	Very light-coloured clay	5 930
	Darker clay. A small specimen, marked 937 (? should be 927), is light-grey clay, rather sandy? ..	1 931

On comparing the Dover section with that of Chatham (described in my former paper), we see that the underground thinning of the Lower Cretaceous beds has gone further at the latter place than at the former, except as regards the Lower Greensand, which is 41 feet thick at Chatham, where two divisions (the Folkestone Beds and the Sandgate Beds) are represented, whilst at Dover we have but 31 feet, of Sandgate Beds only.

At Chatham, however, all the Cretaceous beds below this have vanished altogether, neither Weald Clay nor Hastings Beds having been found; but at Dover the latter series occurs, for the first time in any of the deep borings in the London Basin, and has not yet been pierced through.

In drawing my transverse section, through Chatham, the Hastings Beds were shown as thinning out before the Weald Clay, that seeming to be the more likely event. The reverse is now proved to be the case at Dover, and this may hold at Chatham also.

The absence of the Weald Clay is perhaps less remarkable at Dover than at Chatham, for whilst the thickness at the outcrop south of the latter place seems to be about 600 feet, Mr. Topley remarks that "we have at present no means of estimating the thickness of the clay further east [than the neighbourhood of Maidstone], but it probably thins regularly in that direction, and may not be more than 350 feet thick near Hythe"* , the nearest outcrop to Dover, which place, moreover, is still further eastward.

It may be of use to notice here the probable thickness of the various divisions of the Hastings Beds at the outcrop south-west of Dover. These are as follows, beginning at the top:—The Tunbridge Wells Sand, 150 feet or more; the Wadhurst Clay, perhaps 100 feet;

* "The Geology of the Weald," to which Memoir I am indebted, also, for the thickness of the divisions of the Lower Greensand given above, and of the divisions of the Hastings Beds.

and the Ashdown Beds about 160 feet—or in all more than 400 feet. We should expect, of course, an underground thinning towards Dover, so that, even supposing the boring there to be in the highest division of the Hastings Beds, it is unlikely that there should be any great further depth to be passed through before a Pre-Cretaceous formation is reached.

At p. 44 of my former paper, attention was drawn to the chief points that should guide us in selecting sites for trial-borings, for the purpose of finding out the deep-seated rocks of the London Basin, and Dover was mentioned, in each case, as a good site, meaning thereby the neighbourhood, and not merely the town itself. It was therefore with some satisfaction that I saw various newspaper-accounts of the projected trial-boring now being made by the South Eastern Railway Company at the foot of Shakespeare's Cliff.

My previously expressed opinion, which was shared by my colleague Mr. Topley, is strengthened by the conclusions now come to as to the bottom-beds of the boring at the Convict Prison, where the lower part of the Wealden Series seems to have been struck, at the depth of 849 feet.

As the well begins at a height of 280 feet above the sea, whilst that of the new boring cannot be much above the sea-level, the latter has a great advantage in being at less vertical distance from the deeper beds. The fact that it has also an advantage from the southerly rise of the beds, may probably be more than neutralized by the inference that it is in that direction that the Lower Greensand and the Wealden Beds are likely, one may say are certain, to thicken. The difference of level taken alone would make the depth to the Wealden Beds some 570 feet at the new boring; but, for the reasons above stated, one would rather count on a slightly greater depth.

It seems to me that it would have been a far more satisfactory thing to deepen the existing boring of the Channel Tunnel Company at St. Margaret's Bay, about $2\frac{1}{2}$ miles E.N.E. of the Prison boring, and for good reasons—the first that the trial-boring in question is already 567 feet deep; the second that it is already some feet in the Gault; and the third that it is in a direction in which one may reasonably expect further underground thinning than that of which we have evidence at the prison.

NEW BORING AT STROOD.

In the early part of last year another deep boring in the neighbourhood of Chatham was finished, and although it does not add much to our knowledge of the underground beds there, yet it is of interest from the fact of its success in getting water from the Lower Greensand, and from its agreement with neighbouring sections in the thickness of the Gault found, which exceeds the previous record only by 3, 2, and $1\frac{1}{2}$ feet respectively. Having been noticed only in newspapers, it is worth while to describe it here.

Stewart Bros. and Spencer's Oil Mills.

? About 15 feet above Ordnance Datum.

From an account in the *Chatham and Rochester Observer*, March 6, 1886, and from information from Messrs. Tilley, who made the boring.

Water overflows in large quantity (? 150 gallons a minute), and it overflowed through a small pipe to a height of 45 feet above the ground. Temperature $62\frac{1}{2}^{\circ}$ Fahr.

	Thickness.		Depth.		
	ft.	in.	ft.	in.	
Mud [Alluvium]	42	0	42	0	
[Chalk, 505 feet]. {	Upper Chalk, with flints	305	0	347	0
	Lower Chalk and Chalk Marl.....	194	0	541	0
	Upper Greensand (base of Chalk Marl).	6	0	547	0
Gault (2 inches of rock at the base on one side, 4 inches on the other)	195	2	742	2	
Lower Greensand: fine sharp greenish-grey sand, with water	14	10	757	0	

BORING AT LYDD.

A boring has lately been made for the War Office, at the southern end of Kent, which may be of interest here, as the most easterly one through the lowest beds of the Wealden Series, and the following account may be of some value. The details were given me by Messrs. S. F. Baker and Sons, who carried out the work.

Holmston Camp, 1886.

Water-level 9 feet down.

	Thickness.		Depth.		
	ft.	in.	ft.	in.	
? RECENT BEDS.	Shingle	15	0	15	0
	Boulders.....	4	0	19	0
	Brown sand	13	0	32	0
	Clay, loam and sand.....	4	0	36	0
	Black or grey sand	20	0	56	0
	Pebbles	1	0	57	0
	Black or grey sand	58	0	115	0
	Stiff loam	1	8	116	8
	Clean sharp sand	4	4	121	0
	Loamy clay	5	0	126	0
	Sand	2	0	128	0
	Clay.....	2	6	130	6
	Fine grey sand	0	9	131	3
	Sandstone	2	3	133	6
	Clay and loam	8	0	141	6
HASTINGS BEDS.	Strong blue clay	5	6	147	0
	Stone	3	0	150	0
	White clay	20	6	170	6
	Marl	29	6	200	0
	Loamy clay.....	8	0	208	0
	Marl	42	0	250	0
	Hard stone.....	4	0	254	0
Very hard stone.....	2	0	256	0	

	Thickness.		Depth.		
	ft.	in.	ft.	in.	
HASINGS BEDS	Milder stone	2	0	258	0
	Tough clay.....	4	0	262	0
	Sandstone	1	0	263	0
	Stone	2	0	265	0
	Sandstone and clay	2	0	267	0
	Hard tough clay	2	0	269	0
	Very fine clay and stone	3	0	272	0
	Clay and stone	2	0	274	0
	Mild clay	3	0	277	0
	Very hard clay	12	0	289	0
	Veins of peat and clay	2	6	291	6
	Hard clay	1	6	293	0
	Very hard clay	2	6	295	6
	Mild sandstone, with water.....	2	6	298	0
	Hard sandstone.....	4	0	302	0
	Mild clay	4	0	306	0
	Dark clay	31	0	337	0
	Red and white mild clay	6	0	343	0
	Hard light-coloured clay	7	0	350	0
	Hard red clay	6	0	356	0
Very hard dark clay	4	0	360	0	
Very mild dark clay	3	0	363	0	
Hard light [coloured] clay	2	0	365	0	
Very hard dark brown stone or rock.	3	0	368	0	
Hard sand rock, with water.....	7	0	375	0	
Dark grey loamy soil	4	0	379	0	
Very tough dark clay	13	6	392	6	
Very hard clay	10	0	402	6	

A great number of specimens have been examined, with Mr. Topley's assistance. They consist mostly of pale greyish clays, with some light-coloured mottled clays, and a few very fine compact light-coloured sands, the whole being of like character to the beds that form the lower part of the Wealden Series, the bottom of which would probably be reached at no very great further depth. Some of the specimens are like some of those from the Dover boring.

17. *On a SACRUM, apparently indicating a new type of BIRD, ORNITHODESMUS CLUNICULUS, Seeley, from the WEALDEN of BROOK.*
By H. G. SEELEY, F.R.S., F.G.S., Professor of Geography
in King's College, London. (Read March 9, 1887.)

[PLATE XII.]

THE discovery of the pneumatic condition of the vertebræ in Ornithosaurs and certain Dinosaurs showed that they diverge from Reptiles in structural characters which are typically Ornithic. The augmented number of vertebræ in the sacrum in both those groups also shows a divergence from existing Reptiles, which is markedly Avian. On the other hand, the small number of sacral vertebræ found in the *Archæopteryx* has proved that a bird may have the sacrum no more complex than in Ornithosaurs and Dinosaurs. The bird's sacrum formerly had a simpler structure, just as the intervertebral articulation was simpler; and we expect to find some of the distinctive osteological attributes of existing birds wanting among earlier representatives of the class. This would also be a fair inference from Prof. Huxley's exposition of the sacrum of the fowl. Sacral vertebræ are defined by their nerves uniting to form the sacral plexus; judged by this test, the fowl has five sacral vertebræ. But ossification has extended beyond them, so as to incorporate in the sacrum the four anterior vertebræ which were originally dorso-lumbar, and the five posterior vertebræ which were originally caudal. When the number of vertebræ is reduced, the structure of the sacrum may be simplified. At the present day the most striking character of a bird's sacrum is the absence of transverse processes extending outward from the bases of the true sacral vertebræ, so that deep depressions are formed in its middle region, comparable to the entire sacrum in some Ornithosaurs. These depressions contain the middle lobes of the kidneys, and therefore may be presumed to be due to the way in which the development of those organs governed the ossification. Hence the presence or absence of this osteological character would imply no more than a slight difference in the deep-seated condition of the kidney; so that the renal recess might be wanting, without implying any important difference in organization.

The specimen which I am about to describe wants the modified renal recesses of the sacral vertebræ of the sacrum (Pl. XII. figs. 2, 3), the typically Avian saddle-shaped intervertebral articulation (fig. 4), and the large number of vertebræ commonly found in a sacrum in existing birds. It is in the Fox collection of the British Museum, and is distinguished by the number $\frac{R}{187}$.

This sacrum is 9.6 centimetres long and slightly curved, so as to be concave in length on the ventral aspect (fig. 3), though the original curvature may have been less than the specimen now shows.

The bodies of the vertebræ and neural arches are both higher in the anterior part of the specimen than in the posterior part, towards which the depression steadily augments (fig. 3).

Anteriorly the articular face of the first centrum is transversely ovate, as among many birds, fully 15 millim. deep, and 20 millim. wide, as preserved (fig. 4). It is in the main flattened, apparently slightly concave from above downward, with a sharp peripheral edge, now a little broken and showing fine cellular tissue.

The posterior articular face is much smaller, and is also extended transversely (fig. 5). It measures over 15 millim. wide at the base, and is much narrower below the neural canal, towards which the sides converge upward. It is over 9 millim. deep. There are two small abraded tubercles which look downward, placed at the outer angles of the base. The articular surface of the centrum is flattened, but slightly concave, and has a small prominence extending backward below the neural canal; the whole surface is inclined obliquely forward so as to look obliquely backward and upward. The small articulation for the caudal vertebra, as compared with the intervertebral articulation in the dorsal region, is a character which has not been found in Dinosauria, and, like the transverse extension, is Avian, though the latter character is also found among some Ornithosaurs. The small caudal articulation implies a small tail; and it will subsequently be seen that we are entitled to infer that this tail was of the type which characterizes existing birds.

The sacrum includes six vertebræ, which are perfectly ankylosed together (figs. 1, 2, 3).

The transverse processes (figs. 1, 2, 3, *t*) are given off at the junction of the centrams. They extend from their origin on the sides of the vertebræ up to the neural platform, which is a horizontal lamina, formed by the blending of the neural arches, extending along the sacrum on each side of the neural spine. This platform (fig. 3, *np*) in its anterior part is directed outward and slightly upward; in the hinder part it is horizontal. The height from the base of the centrum to the neural platform at the junction of the first and second vertebræ is 2.2 centim.; at the junction of the fourth and fifth vertebræ the corresponding measurement is 14 millim. The neural platform does not appear to extend to the sixth vertebra. The width of the neural platform at the second vertebra is 14 millim.; at the fourth vertebra it is about 2 millim. wider. The neural spine is broken (fig. 3, *ns*), but appears to form a thin continuous vertical plate from the second to the fifth vertebra (fig. 1, *ns*). Its base is 3 millim. wide in front, but it is stronger in front than behind. As preserved, it is only half a centimetre high in front, and its height posteriorly was less.

The posterior aspect of the sixth neural arch is worn, so that the zygapophyses are lost, but the neural spine is seen to be vertically grooved. The first vertebra has its zygapophysial facets preserved; they have the characteristic oblique, curved, Avian position resting flat upon the neural arch (fig. 4, *z*).

The sides of the centrams are compressed, and the first two show

long concave lateral depressions, in which are impressed ovate apertures of a pneumatic character (fig. 3, *pn*).

The vertebral centrums are nearly equal in length, but become slightly shorter posteriorly, and the sixth is conspicuously short (fig. 2). The first has a length of 17 millim., the second of 16 millim., the third, fourth, and fifth are slightly shorter, and the sixth measures 13 millim.

The general aspect of the underside of the centrum is flattened, with the flattening augmenting posteriorly. The first centrum is decidedly convex from side to side and concave in length, but the longitudinal concavity becomes obliterated with the next vertebra. The transverse measurement is from 12 to 13 millim. In the second vertebra the centrum is a little wider and flatter, and it widens posteriorly because the transverse process descends almost to the level of the base of the centrum, and widens transversely in a direction nearly horizontal. In the third vertebra the width is nearly 15 millim.; in the fourth it is 16 millim., and in the fifth and sixth it is 13 millim.

The first transverse process (fig. 3, *t*) is on the neural arch; but in the succeeding vertebræ they descend, till the base of the fourth process is on a level with the base of the centrum; their antero-posterior extent gradually increases as they extend backward. The sixth vertebra is at first less conspicuous than the others, because its transverse process does not descend to the base of the centrum, from which it is defined by an emargination. All the transverse processes, except the last, are broken (fig. 2), and the measurement across them and the intervening vertebra, as preserved, in no case exceeds 3 centim.; but the abrasion is probably slight, since the processes are as long as in many existing birds, and in some cases the correspondence with birds in contour and length of the processes is absolute.

The side of the sacrum below the neural platform and between the transverse processes appears in all cases to be excavated. The transverse process between the first and second vertebræ is vertical, 15 millim. high and 6 millim. from front to back. The other processes have some resemblances with *Megalosaurus*, but appear to be vertical (fig. 3, *t*) and constricted in the middle, except the last, which is sub-ovate, but little elevated, 12 millim. high and 10 millim. wide.

The neural canal is wider than high (figs. 4, 5).

The only extinct animals with which this type of sacrum can be compared are Dinosaurs and Ornithosaurs. With described Dinosaurs, notwithstanding many general points of resemblance, it has comparatively little in common. No genus approaches it more nearly than *Hypsilophodon*, in which the character of the sacrum is altogether different in the transverse processes of the first sacral being given off on a level with the base of the centrum, while in the later vertebræ these processes originate higher up on the sides of the centrum. Mr. Hulke has described a shallow median groove as occupying the ventral surface of the centrums of the sacrum in that genus; but it is very different in character from the vascular groove

(fig. 2, *vc*) seen in the median line of this fossil, which is better compared with the similar groove seen on the sacral centra in Vultures and *Ichthyornis victor*. If we were to say that the general analogy with Dinosaurs is such as to give a reasonable probability that some member of the group will be found to resemble it, the prediction would not seem inadmissible; but it would only be another mode of recognizing the approximation of the sacrum in Dinosaurs towards that structure in birds. Unfortunately nothing is known of the sacrum in British Dinosaurs with pneumatic vertebræ; but if the American types which are thus characterized may be taken in evidence, the sacrum has nothing in common with the sacrum described which would tend to affiliate it to the Dinosauria.

The sacral vertebræ in Ornithosaurs are also united into a sacrum. Von Meyer has stated the number of vertebræ in species from the Solenhofen Slate at from 5 to 6. They are ankylosed at a sufficiently late period for the vertebræ not to show the diminished length seen in the sacrum of a bird. There is a resemblance to the fossil in the transverse form of the articular face of the centrum, a less resemblance to the concave articular surface of the first sacral vertebra, and no resemblance to the flat or concave articulation of its last vertebra, which in Cretaceous Ornithosaurs is convex. There is a general resemblance in the pneumatic character of the bones; but I am not aware that any Ornithosaur has the foramina similarly situate, or that the structure of the sacrum is such as this fossil shows.

Turning to birds, the form of the articular face of the first sacral vertebra is variable, so that the Gannet, which has the lower dorsal vertebræ almost biconcave, has the articular face flat, with a central pit in the first vertebra of the sacral mass, which cannot be termed sacral, since it carries ribs. There is therefore no insuperable difficulty in the absence of the typical Avian articulation of the first vertebra in interpreting the sacrum as that of a bird, since the Avian articulation has already been found to be absent in the sacrum of *Enaliornis* from the Cambridge Greensand, and in that of *Ichthyornis*, figured by Professor Marsh.

In *Ichthyornis dispar** there are ten vertebræ in the sacrum; but the specimen forms an interesting link with our fossil, in differing from existing birds by not having the transverse processes of the middle sacral vertebræ elevated from the centrum on to the neural arch. It is true that they rise a little on the last three sacral vertebræ of *Ichthyornis dispar*, but then there are more vertebræ in the sacrum than in this fossil. *Ichthyornis*, however, is no near ally.

Among existing birds, I was led to seek an elucidation of the fossil among the Penguins rather than any other type, because their dorsal vertebræ present the opisthocœlous deviation from the Avian articulation, which has already offered a suggestive explanation of the opisthocœlous articulation in certain vertebræ of some Dinosaurs, towards which the sacrum may approximate in a general way. The sacrum of *Aptenodytes*, however, is typically Avian. Yet in the

* *Ichthyornis victor* may be generically distinct.

large *A. Forsteri*, which is not dissimilar in size, there is enough in common with the fossil to make some comparisons instructive.

In the skeleton of *Aptenodytes Forsteri*, in the Osteological Collection of the British Museum, numbered 1197 *b*, the presacral vertebra is imperfectly anchylosed to the sacrum, and comes away leaving a rugose surface, which is slightly convex from the ventral margin to the neural canal. This is the converse condition to that seen in the fossil. But just as birds have the vertebræ biconcave, flat, and opisthocœlous, as well as saddle-shaped in the intercentral articulation, there is no antecedent improbability in an extinct bird having the articulation procœlous.

This Penguin's sacrum contains ten vertebræ, and differs from the fossil in many details. It has not the median ventral canal, nor the pneumatic pits; but the Penguin is exceptional among water-birds in that respect. The transverse processes of the early sacral vertebræ of the Penguin are inclined forward as they ascend from the centrum to the neural platform, so that the process rises from one centrum to the neural arch in front of it; whereas in the fossil the processes are vertical, and given off at the junction of two centra. The middle three sacral vertebræ of the Penguin, have the character already discussed as typical of existing birds, the attachments for the ilium being given off from the neural arch, and this is an important difference from the fossil. But the posterior widening of the transverse processes seen in the Penguin is well marked in the fossil. And the last vertebra has the vertically ovate tubercle for the ilium upon its own centrum, and is conditioned in every respect in the same way in the Penguin (fig. 6) and the fossil (fig. 5). The correspondence is almost as close in the character of the transverse processes and zygapophyses of the first sacral vertebra. The resemblances further include the flattened neural platform, which is better developed in the fossil than in the Penguin. The neural spine in the fossil is thinner, more as in ordinary birds, and apparently lower than in the Penguin. Another resemblance is in the descent of the transverse processes from the neural platform in the first vertebra to the base of the centrum in the fourth vertebra, in consequence of which the first two vertebræ have their bodies compressed from side to side (fig. 3). In both types the bodies of these vertebræ are of similar form, the first rather flattened on the underside and concave in length, the second widening as it extends posteriorly. Though the centra in the fossil are approximately of equal length, their length diminishes in the middle of the sacrum in a way which is Avian, though the shortening is less than in existing birds. From the Avian form of the last sacral vertebra it may perhaps be legitimately inferred that the tail was not unlike that of a Penguin.

From this comparison it is manifest that the differences which the fossil shows from existing birds are three: first, the small number of vertebræ in the sacrum; secondly, the absence of the sacral recesses for the middle lobes of the kidneys; and, thirdly, the form of the articular face of the first sacral vertebra. Fossil birds lessen the importance of these differences: first the *Archæopteryx* has as

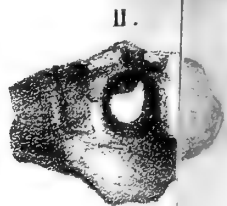
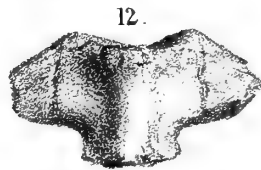
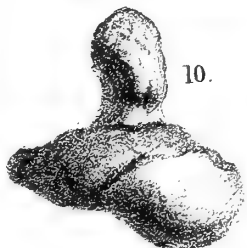
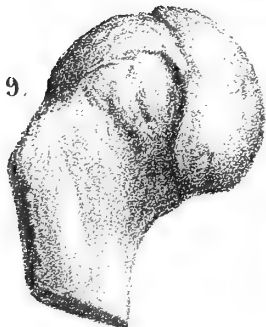
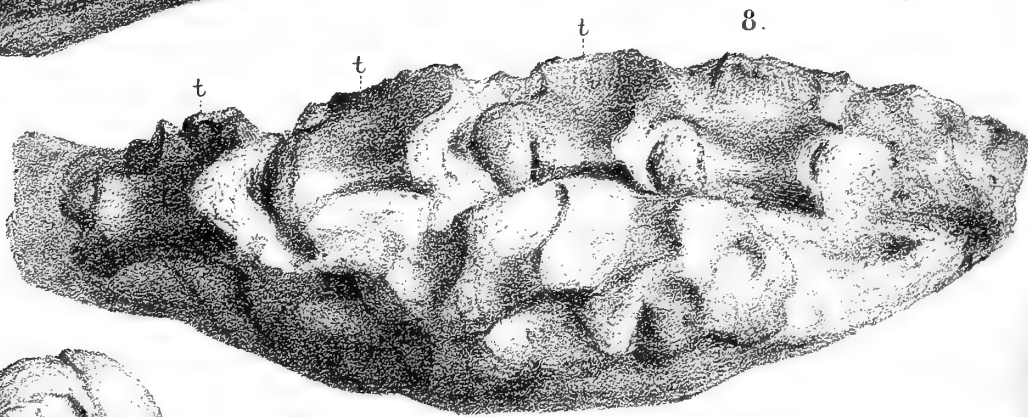
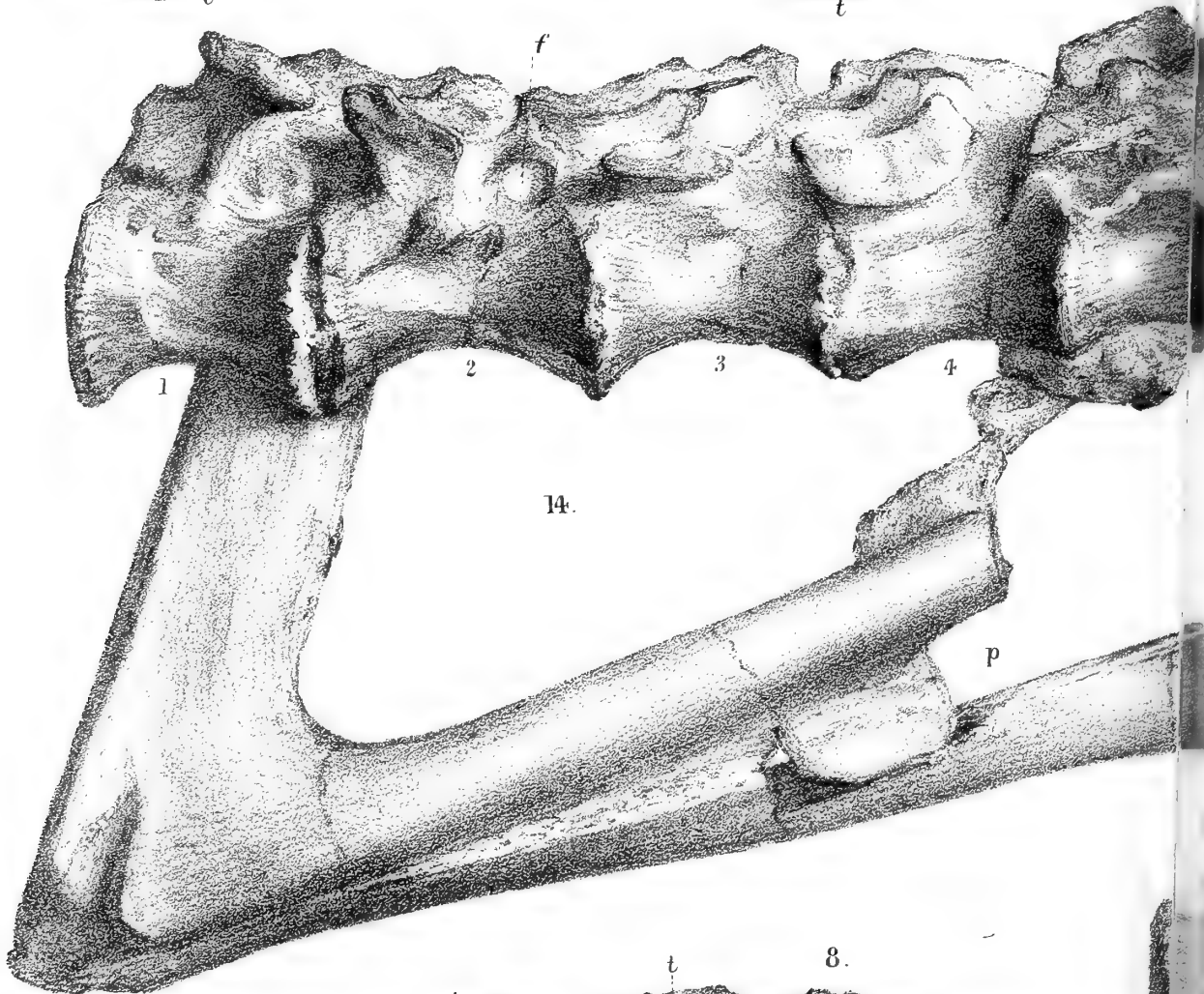
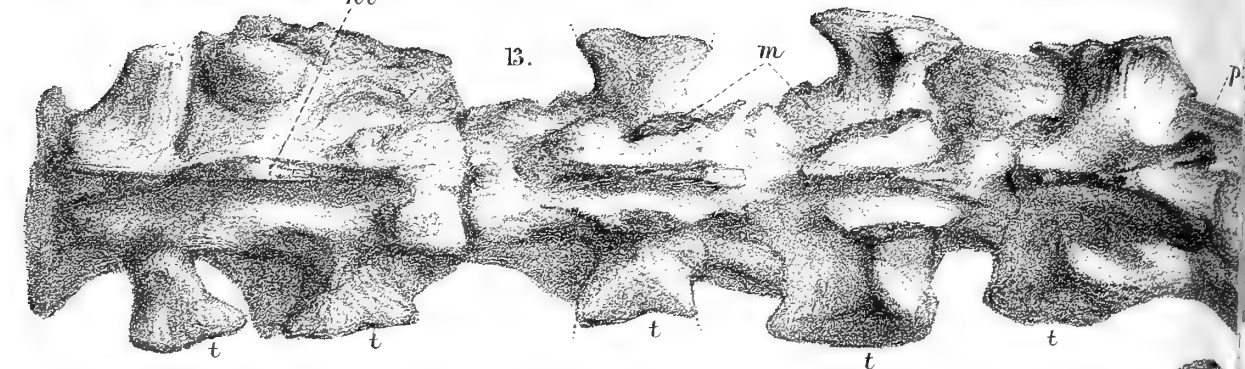

Michael del. et lith.

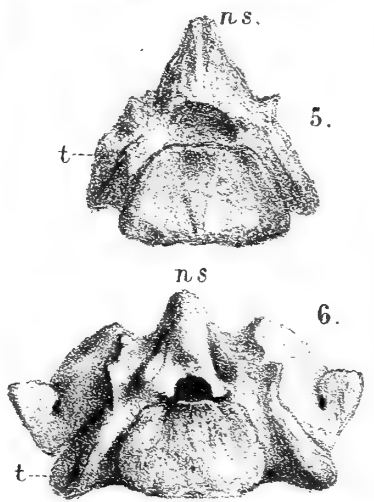
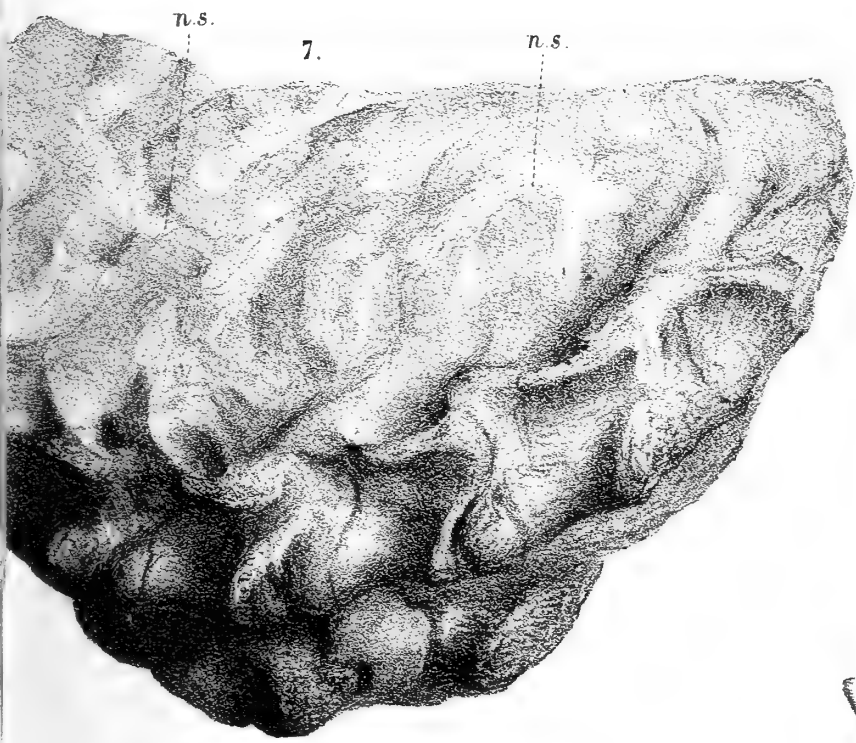
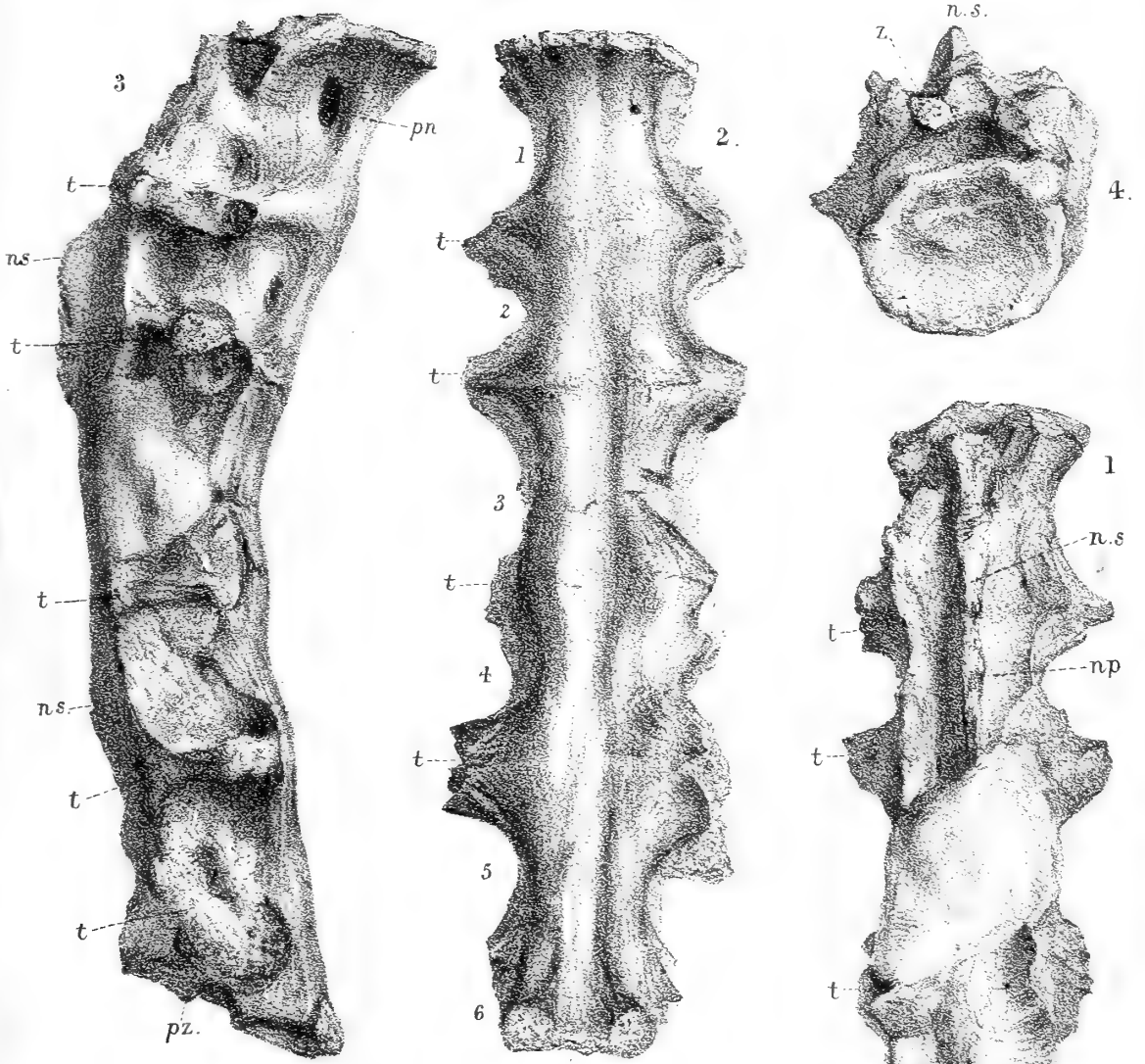



few vertebræ in the sacrum; while *Ichthyornis dispar* has no renal recesses in the middle of the sacrum; and the Gannet makes a sufficiently near approximation to the form of the articulation to remove any improbability as to its being a modified Avian form.

I therefore venture to submit, on the evidence of the resemblances and considerations which have been discussed, that *Ornithodesmus* is probably a bird; but it differs from existing birds, so as to suggest that it is a link towards lower forms. It cannot be placed in any existing division of the class, but approximates towards Dinosaurs in a way of which no bird had previously given evidence.

I am indebted to Dr. Henry Woodward, F.R.S., for facilities afforded me in making this study.

EXPLANATION OF FIGURES.

PLATE XII.

ns, neural spine; *t*, transverse process; *z*, prezygapophysis; *pz*, postzygapophysis; *np*, neural platform; *pn*, pneumatic foramen; *vc*, vascular groove.

- Fig. 1. Dorsal view of sacrum of *Ornithodesmus cliviculus*.
 2. Ventral view of sacrum.
 3. Lateral view of sacrum.
 4. Anterior articular end of first sacral vertebra.
 5. Posterior articular end of last sacral vertebra.
 6. Posterior articular face of last sacral vertebra of *Aptenodytes Forsteri*.

(For the DISCUSSION on this paper, see p. 219.)

18. On *HETEROSUCHUS VALDENSIS*, Seeley, a PROCELIAN CROCODILE from the HASTINGS SAND of HASTINGS. By H. G. SEELEY, F.R.S., F.G.S., Professor of Geography in King's College, London. (Read March 9, 1887.)

[PLATE XII.]

THE specimen in the British Museum, numbered 36555, came there in the second Mantellian collection, which was acquired after Dr. Mantell's death. It is part of a thin ironstone nodule, 10 centim. long and 6 centim. wide, from the Hastings Sand of Hastings, manifestly water-worn, but containing vertebræ which have not hitherto been determined. The nodule (Pl. XII. fig. 7) displays the remains of fully a dozen vertebræ, which extend round the nodule in parts of more than one coil, so arranged as to expose the ventral surface or bodies of the vertebræ, towards the external margin of the concretion. These vertebræ indicate a procelian Crocodile of small size; and although the remains are so imperfect, I refer them to a new genus, since their forms are different from those of any Purbeck Crocodiles or other described Crocodilia.

The nodule displays some other vertebrate remains which may possibly belong to another kind of animal. Thus in a transverse fracture the outlines may be traced of two long ovals which extend in the same axis, and may represent the superior aspect of the parietal region of a small skull, in which each temporal fossa is 13 or 14 millim. wide and 7 millim. long. The external surface appears to show a very fine punctate ornament, not unlike that seen in some small Purbeck Crocodiles; and what might be the quadrate bone is seen to extend in an outward direction as it is prolonged distally. No procelian Crocodile has the temporal vacuities elongated in this way; but from the imperfect preservation and small size I am doubtful whether the skull should be referred to the same animal as the vertebræ, on the hypothesis that it is to be included in the Procelia.

On the worn external surface of the nodule, somewhat below the remains of the sacrum, are some obscure outlines of bones, which can only be followed with difficulty, but which may be pubis and ischium; and in the position in which the acetabulum might exist, there is a well-defined hemispherical pit. These bones are much smaller than would have been expected; but their proximity to the sacral vertebra makes it important to remark that the acetabulum is that of a lacertilian, while the forms of the bones which combine to form it are not crocodilian. In the possibility that all the remains may be portions of one animal, this fossil would diverge from existing Crocodiles in a direction of which no crocodilian has hitherto given evidence.

The vertebræ include one late cervical, eight dorsals, and two which may be classed as sacral. These vertebræ are remarkable

for a completeness of ossification which existing Crocodiles do not show. I have no doubt that the specimen was mature, on account of the length of the neural spines (fig. 7, *ns*). All traces of sutures are obliterated, and there is no trace of the inflation which, in living Crocodiles, commonly marks the line of the neuro-central suture. The articular ball of the centrum was as well ossified as in a lizard or serpent (figs. 7, 8), and the ridges on the upper part of the neural arch are defined with a sharpness unknown among living Crocodiles, and suggestively Dinosaurian. The most distinctive features, however, of these vertebræ are, the side-to-side compression of the bodies of the centra, and the comparatively depressed neural arch, with its strong zygapophysial ridges and well-developed neural spine. The inferior V-shaped approximation of the sides of the centrum, which throws the neural arch out laterally above, is the principal generic character seen in the dorsal region. The cervical vertebræ are so imperfectly exposed that it is difficult to draw generic characters from them; but if the one specimen seen is rightly determined, it shows a fundamental difference from procœlian Crocodiles in the elevation of the facet for the rib upon the neural arch to a position which almost adjoins the prezygapophysis. But as these vertebræ are not continuous with the dorsal series, and there is no diapophysial tubercle on the neural arch, I hesitate to draw what would otherwise be a legitimate conclusion as to affinities from this character.

Two or three cervical vertebræ are present, but only one is partially free from the matrix. The second specimen shows the outline of the neural arch from above; but the neural spines, which had the usual anterior position, are not preserved. The measurement is 24 millim. from the prezygapophysis to the postzygapophysis, and about 17 millim. from side to side over the zygapophysial facets, while the least side-to-side measurement in the median constriction is 8 millim. The one vertebra which is partly free, though badly preserved, shows the neural arch to have been greatly depressed, so that the height from the base of the centrum to the zygapophysis is about 15 millim., and this is apparently also about the length of the centrum. The left side of the centrum is subquadrate and concave, with a small circular facet for the diapophysis external to and impressed immediately below and behind the prezygapophysial facet. There is no trace of a tubercle, such as is seen in Crocodiles; though the parapophysis has the usual oblong form, compressed from above downward, and, though quite on the base of the side of the centrum, is further distant from its anterior border than in existing Crocodiles. The under surface of the centrum is too imperfectly preserved to indicate whether a hypapophysis was developed; but the emargination of the undersides of the bases of the parapophysial tubercles defines a constricted base to the centrum which is not seen in existing Crocodiles.

Seven dorsal vertebræ extend in continuous sequence, and their centra appear to increase slightly in length as they extend backward. All are marked by the obliquity of the cup and ball, which is rather more pronounced than in existing Crocodiles; but as the

inferior margin of the cup is in every case worn, the obliquity appears greater than it was in life. Each centrum is about 19 millim. long; the articular ball is well rounded. The form of the centrum is compressed from side to side below, with the base rounded. The sides are concave, without any thickening of the bone in the position where the neurocentral suture is usually present. The transverse processes are broken, but enough remains to show that the usual posterior concave incision existed between the transverse process and the postzygapophysis. From the hinder margin of the transverse process a sharp ridge descends in a concave curve as it extends backward to the outer border of the articular ball. Posterior to this ridge the bone of the neural arch is impressed, and ascends to the postzygapophysis. The underside of the transverse process (fig. 8, *t*) which was compressed from above downward in the usual way, appears to have been convex at its base. From both the anterior and posterior zygapophyses well-defined compressed rounded ridges ascend and converge, as they extend inward towards the neural spine. Between these ridges is a concave recess with a flat base, forming the inward termination of the upperside of the transverse process. The height from the base of the centrum to the transverse process is greater in the anterior vertebræ of the series than in the later ones. In the third it is 15 millim.; towards the end it is scarcely more than a centimetre. The neural spines are well developed; they ascend vertically in the anterior vertebræ and are inclined slightly forward in the later ones. The height from the base of the centrum to the summit of the neural spine is about 33 millim. The spine widens a little towards its summit, which is convex from front to back; its anterior and posterior margins are slightly concave.

A lumbar centrum is present, and exhibits a rather narrow neural canal.

The sacral vertebræ are imperfectly preserved; there were probably two. From the second the transverse processes are completely lost, but the first shows these processes to have been quadrate and strong. As in existing Crocodiles, they are concave in front, flattened above, and, as they extend outward, depressed below the prezygapophyses. The transverse measurement across the processes, as preserved, is 25 millim.

The vertebral characters described show divergences from existing Crocodilia, such as on the whole are approximations towards Dinosaurian types of Wealden age, a condition of more interest from the Crocodiles of the Gosau beds having shown some approximations in vertebral characters to the Gosau Dinosaurs.

A few isolated vertebræ of similar character were collected by Dr. Mantell, from Tilgate, and from Brook in the Isle of Wight. A small caudal vertebra from Tilgate has the base of the centrum compressed from side to side and rounded, with a concave impression above the middle of the side, immediately beneath the transverse process. The prezygapophysis is long and directed upward and outward. The articular cup is perfectly circular. The centrum is

13 millim. long. Another Tilgate caudal vertebra, later in the series, is about 15 millim. long. It possessed the transverse process and well-developed procœlian articulation; but the neural arch is greatly shortened and limited to the middle of the centrum, as in some Dinosaurs. The procœlian vertebræ of similar size are from Brook. The specimen 36524, however, has the centrum as well rounded from side to side as in existing Crocodiles, and is not referable to this genus.

It may be interesting to remark that although this is the oldest procœlian Crocodile hitherto described, the British Museum contains a single cervical vertebra, no. 48244, from the Purbeck beds, which has a well-defined procœlian cup, and the cervical neural arch is constructed on the usual crocodylian plan.

The existence of this form of vertebra in the Purbeck beds accentuates the apparent difference of the cervical articulation for the rib in the Wealden specimen, a difference sufficiently remarkable to make more striking modifications of the skull and pelvis not impossible.

I am indebted to Dr. Henry Woodward, F.R.S., for the facilities afforded me in studying and describing this specimen.

EXPLANATION OF FIGURES.

PLATE XII.

ns, neural spine; *t*, transverse process.

Fig. 7. Slab, showing sequence of dorsal vertebræ of *Heterosuchus valdensis* Seeley.

8. View of the same slab, showing the underside of the centnums of the dorsal vertebræ.

19. On PATRICOSAURUS MEROCRATUS, *Seeley*, a LIZARD from the CAMBRIDGE GREENSAND, preserved in the WOODWARDIAN MUSEUM of the UNIVERSITY of CAMBRIDGE. By H. G. SEELEY, F.R.S., F.G.S., Professor of Geography in King's College, London. (Read March 9, 1887.)

[PLATE XII.]

No lacertilian has hitherto been recorded from the Cambridge Greensand. The comparative rarity of this group of animals in the deposit is evidenced by the fact that only two fragments of lizard-bones are known to me to have been found during the whole period in which its fossils have been collected. One of these is a sacral vertebra with the transverse processes broken away, which was, I believe, collected by the Rev. H. G. Day prior to 1859. The other is the proximal end of a femur obtained recently by Mr. A. F. Griffith. Slight as is the material, it is worth recording as evidence of a terrestrial animal of a relatively large size, and more nearly allied to existing lizards than are the other Cretaceous representatives of this order of animals.

RIGHT FEMUR (Pl. XII. figs. 9, 10).

The proximal end of the right femur now described is larger than the corresponding bone in the largest existing Monitor. It was unfortunately fractured, subsequently to being mineralized, at a point below the articular head, just where the shaft becomes triangular, so that the length of the bone and its distal characters are entirely conjectural. The shaft consists of dense bony tissue, as in existing lizards, with a small medullary cavity. The fragment is about 3 centim. long. It has the characteristic vertical compression and forward curvature of the convex articular head, and the usual front-to-back compression of the inferior trochanter, which, however, extends further proximally than in existing lizards. The fragment has experienced a little attrition, and a thin external epiphysial layer of bone is partly removed from the proximal articular surface—a character of some interest as repeating the epiphysial growth which is often seen in existing lizards, but in a form no thicker than in the limb-bones of some breeds of domestic fowls, like Bramahs, when a week or two old.

The proximal articular surface is semicircular from front to back; it is 2 centim. wide. Its superior outline, viewed from the proximal end, is comma-shaped, being a centimetre wide in front, and becoming narrower as it extends backward. From above downward the articulation is convex, about 12 millim. thick in the middle, and narrowing away behind. The convexity of the anterior part of the smooth rounded articular head is suggestive of the limb having been carried in a position well raised from the ground. The axis of the articular head of the bone is directed inward and very slightly

upward. The superior aspect of the shaft, which the articulation terminates, is concave; and the concavity runs into the middle of the articulation to give it its crescentic or comma-shaped form (fig. 9). In the Nilotic Monitor this depression receives a talon-like spur from the proximal epiphysis. The anterior margin of the bone below the articular head is concave as it extends distally, but the posterior margin of the superior aspect of the shaft was thicker, trochanteroid, and probably convex in length; though, being a little abraded, it can only be seen to widen and inflate the bone below and behind the articulation. As already remarked, the shaft is triangular; and I am disposed to term the other two sides of the bone anterior and posterior, as they lie in front of or behind the inferior or great trochanter. At its fracture the shaft measures one centim. from above downwards, and 9 millim. from side to side; the outline is flat above and behind, more convex and wider at the inferior trochanteric margin than at the other angles.

The great trochanteric ridge extends longitudinally on the middle of the underside (fig. 10), converging rapidly downward to the shaft, and is vertical to the superior aspect of the shaft, like the stem of a capital T: the thickness through the bone at its proximal termination is about 17 millim., though the superior proximal expansion of the articular surface increases the thickness of the bone to about 22 millim. This characteristic lacertilian trochanteric process extends to within nearly a centimetre of the proximal extremity of the bone; it is concave in length, curving forward proximally, is about 6 millim. thick, and somewhat flattened below, with the anterior margin rounded.

The anterior aspect of the bone is concave, so that the constriction of this side, combined with the concavity of the superior surface, gives a well-defined character to the articular head, almost like a neck, if it were not that these sides converge anteriorly to form a sharp ridge which unites them, and becomes flattened as it extends down the shaft. There is a mark of strong muscular attachment, of which a centimetre is preserved, which commences one centimetre below the trochanteroid ridge, on the inferior border of its anterior aspect.

The posterior aspect of the bone can only be described as saddle-shaped, being convex in length and channelled with a wide, smooth, concave depression, which lies between the inferior and superior trochanters, and curves forward beneath the articular head. The width across the trochanters, where greatest, is 18 millim. There is a small pit about 3 millim. in diameter, which lies immediately behind and below the posterior trochanteroid margin, so as to be between that process and the narrow termination of the articulation of the proximal articular surface. Owing to the posterior thickening of the lateral margin of the great trochanter, its inferior border is wider than the part which rises from the head.

There is no existing lacertilian which this fossil closely resembles. Compared with the Monitor, the more striking differences are that the fossil has the articular surface more developed on the upper and anterior parts of the head, so as to form a deep concavity in the

middle of the superior aspect. Secondly, the great trochanter extends further proximally, but is not developed to quite the same depth distally. The well-marked longitudinal posterior concavity defined by the reflected posterior margin of the trochanter is also a distinctive feature. The comparatively thin proximal epiphysis seems to mark the beginning of a condition of the extremities which has attained greater development in modern lizards. Yet the configuration of the bone is in no sense embryonic or indicative of imperfect ossification, but rather shows that the modern lizards have diverged from this ancient type so far that it is likely to belong rather to a subordinal modification than to an extinct family.

FIRST SACRAL VERTEBRA (Pl. XII. figs. 11, 12).

It is impossible to say that the vertebra which is now to be described pertained to the same species as the femur, for there is no record of the exact locality in the neighbourhood of Cambridge from which the specimens were obtained; but since there is nothing inconsistent with natural association in the characteristics of the two bones, and the sacrum, while conforming to the general plan of existing lizards, yet differs from them in notable characteristics of the neural arch, I have not hesitated to describe them as probably the remains of the same species.

The fossil consists of the first sacral vertebra made up of the complete centrum, the neural arch, which has lost the neural spine, and the prezygapophyses; and the transverse processes which are fractured through the middle were probably complete when the specimen was discovered. These parts are united together by conspicuous sutures (fig. 11).

The centrum is depressed, 11 millim. long and 14 millim. wide, to the sutures with the sacral ribs, which form quadrate transverse processes. The inferior surface is concave in length and convex from side to side in the middle, becoming depressed laterally and constricted posteriorly from side to side, so that behind the transverse processes the bone narrows towards the posterior surface to a width of 9 millim.

The anterior articular cup is about 11 millim. wide and 7 millim. deep, transversely reniform, with a concavity above impressed by the neural canal, and the convexity below. It may have been slightly deeper, since the inferior margin is worn. It is moderately concave from side to side and from above downward, and shows in the middle a small notochordal pit. The posterior articular surface is much smaller and, though not perfectly preserved, may be described as semicircular, 9 millim. wide and nearly 5 millim. deep, very slightly convex from side to side, but on the whole flattened, with a small central notochordal pit.

The neural arch is sharply defined by the sutures which separate it from the transverse processes; but the suture which divides it from the centrum placed at the summit of the anterior articular cup is only seen on the right side. The width of the neural arch

is 13 millim., but rather more dorsally, and slightly less on the centrum as the sutures with the transverse processes diverge upward. The prezygapophyses are broken away, but the width across them from side to side was about 9 millim. Behind the transverse processes the bone is notched in, so that the neural platform projects backward to form the postzygapophyses, and the measurement is a little less over them from side to side than over the prezygapophyses. The dorsal aspect of the neural arch is the most distinctive feature of the specimen, each half of it being horizontal and flattened, with a depression at the base of the neural spine, which was narrow and is broken away. There is no trace of zygapophysial ridges such as occur in *Varanus* and some other lizards. The neural canal is vertically ovate in front, and reaches nearly the height of the neural arch, 7 millim., while the transverse measurement is over 5 millim.

The transverse processes are directed outward and backward as in the first vertebra of existing lizards (fig. 12). They are compressed from side to side and from above downward, so that the transverse section is vertically oblong and inclined a little backward. The process extends from the base of the centrum to the platform of the neural arch, and is 11 millim. deep at the suture. It is 8 millim. wide at the base and 5 millim. wide at the neural platform, so that the flattened anterior aspects look obliquely forward, outward, and upward. The posterior aspect is vertical, with a transverse concavity in the middle. The posterior margins of the processes appear to have been sharp and angular, while the anterior margins are slightly rounded. Both upper and under surfaces are flattened and converge outward. The width of the fragment, as preserved, is 24 millim.

The most distinctive features of this vertebra are found in the convexity of the base of the centrum, and in the transverse processes rising to the level of the flattened neural platform.

I am acquainted with no form of sacrum which approximates toward this fossil so as to need to be distinguished by further comparison.

EXPLANATION OF FIGURES.

PLATE XII.

(The figures are of the natural size.)

- Fig. 9. Antero-superior aspect of femur of *Patricosaurus merocratus*.
 10. Proximal aspect of the same bone.
 11. Anterior aspect of first sacral vertebra.
 12. Inferior aspect of first sacral vertebra.

DISCUSSION.

Mr. HULKE said *Ornithodesmus* was another old acquaintance of his. Several bones were found with it, now lost. He had looked upon it as Pterodactylian.

Mr. BLANFORD suggested that the name *Patricosaurus* should be founded on one specimen, not on the two, lest they should prove to belong to distinct animals, and confusion result as to which should bear the name.

Prof. SEELEY said that out of many thousands of bones from the Cambridge Greensand that had passed through his hands these were the only fragments of Lizards. He thought no others were likely to be found for some time, and there was little chance of any remains of two Lizards occurring. If, however, one bone were to be selected as the type, he would take the femur, to which the specific name referred.

With regard to *Ornithodesmus*, he said that it differs from all Ornithosaurs in having a horizontal neural platform running through the sacrum, and from which a continuous neural spinous ridge rises. The transverse processes and pneumatic foramina did not tend to approximate the two groups; while, so far as he was aware, the Wealden Ornithosaurs had the ventral side of the sacrum much more convex from side to side. He further pointed out that the texture and form of the sacral vertebræ differed from those of known Pterodactyles.

20. On ARISTOSUCHUS PUSILLUS (Owen), being FURTHER NOTES on the FOSSILS described by Sir R. OWEN as POIKILOPLEURON PUSILLUS, Owen. By H. G. SEELEY, F.R.S., F.G.S., Professor of Geography in King's College, London. (Read March 9, 1887.)

[PLATE XII.]

THE Palæontographical Society in 1876 published a memoir upon a Wealden fossil, which Sir Richard Owen described as *Poikilopleuron pusillus*. These bones were then in the collection of the Rev. W. Darwin Fox, and, with the exception of the figured dorsal and caudal vertebræ, subsequently passed into the British Museum, with the Fox Collection. By the kindness of Dr. Henry Woodward, F.R.S., Keeper of the Geological Department, I have been able to examine these remains, and I would express my indebtedness for the facilities given me in making the study of which the results follow.

A question necessarily arises as to the grounds on which the animal is referred to the genus *Poikilopleuron* (recte *Pœcilopleurum*), because these are stated to be "the shape and texture of the vertebræ, and especially the latter." This statement implies that when a dorsal vertebra was divided vertically and longitudinally, it was found to have a medullary cavity, comparable to that seen in the vertebræ of *Poikilopleuron*. In the caudal vertebra the cavity is larger. Dr. Leidy, who has recorded a vertebra of the *Poikilopleuron*-type in the Cretaceous rocks of Colorado, remarks that an internal cavity of like character was only known to him in the caudal vertebræ of the Ox; but it is probably not rare among Dinosaurian reptiles. Mr. Hulke has shown that the character is also found in *Megalosaurus*, and other genera with hollow vertebræ have been described by Profs. Marsh and Cope. Whatever the value of this character may be, I submit that it is not generic, while there is no evidence which would associate any group of osteological characters with chambered vertebræ of this type.

Mr. Hulke has advanced some evidence to show that *Poikilopleuron* is *Megalosaurus*, and it will be admitted that the correspondence in form and character of the caudal vertebræ, and in the distal end of the tibia in these Oolitic Dinosaurs, if insufficient to establish absolute identity, at least proves a close affinity between them. And therefore the conclusion is legitimate that the resemblances found in the tail extend substantially to the sacrum, and that the same type of sacrum is found in *Poikilopleuron* as in *Megalosaurus*. When examining the validity of the genus *Poikilopleuron* Mr. Hulke did not discuss the sacrum, which constitutes the chief part of the evidence for the species *Poikilopleuron pusillus*.

If Sir Richard Owen is correct in his description of the sacrum of that fossil in referring only two vertebræ to the sacral region, and if the sacrum of *Megalosaurus* consists of five anchylosed vertebræ,

it is manifest, I submit, that the *Poikilopleuron pusillus* and *Megalosaurus Bucklandi* belong to two dissimilar genera. But the attempted affiliation of the Wealden fossil, now under discussion, to the genus *Poikilopleuron* does not establish the sacral characters of the genus *Poikilopleuron*, or furnish any ground for associating the genus with the Crocodilia. The characters assigned to this fossil would rather go to show that it belongs to a genus which can have no near affinity to *Poikilopleuron*. In his Report on British Fossil Reptiles, Sir R. Owen fully described the characters of the sacrum of *Megalosaurus*, and he there points out that the neural arch is shifted in position, so that it overlaps the centroms of two contiguous vertebræ, as in the Ostrich and other birds and some Chelonians, so as to cause the perforation for the sacral nerve to be placed above the middle of the centrum, and that the sacral ribs are given off transversely at the junction of the bodies of the vertebræ. When the fossil named *Poikilopleuron pusillus* is examined, both these conditions of the Dinosaurian sacrum are found to be wanting. Each sacral centrum supports its own neural arch, the neural foramen has the same relative position as in other parts of the vertebral column; and the sacral ribs are given off from the bodies of the vertebræ, and not from the suture between them. It is therefore evident that the fossil is far removed from *Megalosaurus*, and inferentially from *Poikilopleuron*. As it differs in fundamental characters from known Dinosaurs, while there are strong reasons for believing it to be Dinosaurian, I regard it as the type of a new genus, *Aristosuchus*.

Sir R. Owen has figured some bones which were associated with this sacrum (see Pl. XII. fig. 14). There is a median symmetrical bone, to which are attached portions of a pair of rib-like bones, on which the author observes, "the nearest guess I can make as to their nature is that they represent part of the series of abdominal ribs with their sternum." These remains I regard as the pubes.

An ungual phalanx is figured on the same plate, and briefly described as being "of the rapacious type." This fossil I think should probably be rejected, as not being a portion of the same animal, for it shows all the characters of a claw-phalange from the fore limb of an Ornithosaur, though it may be observed that in *Laelaps* the claw-phalanges are as much compressed from side to side. With these differences in the interpretation of the remains a new description of their characters becomes a necessity.

I will first examine the pubic bones and assume, as Sir R. Owen has done, that these bones are in natural association with the sacrum, with which they are still closely connected by matrix, though they are displaced and are twisted round, so that the anterior border is directed posteriorly.

The pubic bone is imperfect proximally, and the expanded portion which united with the ischium and ilium is lost. The parts preserved are the anteriorly directed, distally extended, rod-like parts of the pubes, which converge towards their distal extremities, where they merge in a horizontal posterior extension capable of assisting

in the support of the weight of the body when at rest. This type of pubis, which Professor Marsh has described in *Allosaurus* and *Cœlurus*, has not hitherto been detected in this country, but may be present in the Wealden rocks in other species; for while studying this specimen, Dr. Henry Woodward submitted to me the pubis, imperfect distally, of a type very similar to *Cœlurus*, from Tilgate. This corroboration is the more interesting as the Sussex type of animal shows the proximal end of the bone.

The pubes are somewhat crushed together (fig. 14, *p*); I accordingly drew the anterior aspect of one of the bones in its natural position, and repeated it, reversed, on the opposite side, so as to reproduce the form which the pubic bones show when seen from the front (see woodcut below), with the result that a close general resemblance was established to the pubis which Marsh has referred to *Cœlurus*; and without attaching too much taxonomic importance to this fact, it establishes the interest of the fossil, in being a European representative of an American type.

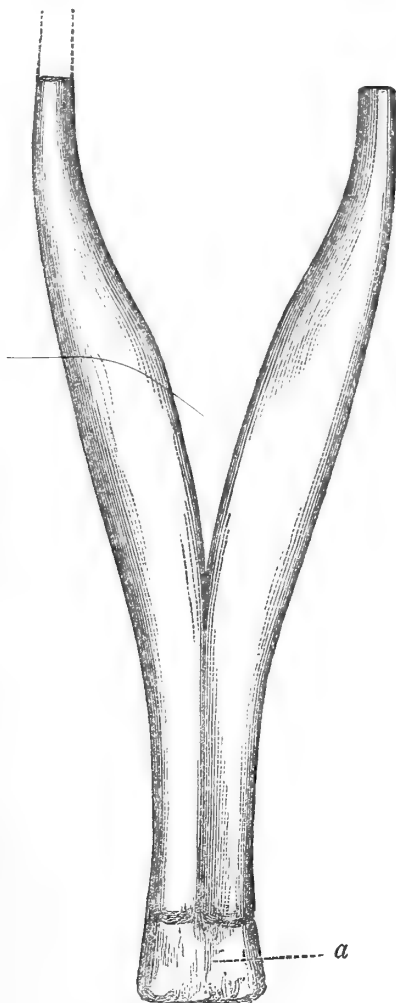

Anterior aspect of pubic bones of *Aristosuchus* restored. $\frac{1}{2}$ nat. size.

a. Unossified extremity of the ventral keel.

The part of the pubic bone preserved in this specimen extends distally for 13 centimetres. Where the bones converge distally they unite at an angle of about 60° with the posterior extension

which extends like the metal of an adze from the haft. Where the bones are fractured proximally they are compressed from side to side, and extend upward with a slight sigmoid curve inward, which is completed distally by the convergence of the bones. At the proximal fracture the bone measures 12 millimetres in the antero-posterior direction, and 6 millimetres from within outward, with the borders rounded in front and behind, but a linear muscular furrow ascends the inner posterior border of the bone. As the bone expands a little in antero-posterior extent as it extends proximally it curves a little forward, making the anterior border of the proximal end of the bone slightly concave, and the posterior border very slightly convex. All the middle portion of the bone preserves about the same antero-posterior measurement of 8 millimetres; but distally the measurement increases by an expansion which is chiefly behind the median axis of the bone, till at its line of junction with the posterior distal expansion its width is 2.5 centimetres.

The middle of the shaft is well-rounded externally, but as the bone widens distally this external surface begins to be flattened till it merges in the flat distal posterior expansion. But the middle of the shaft is compressed from front to back, so as to form a sharp internal edge, and here the measurement from within outward is 13 millimetres. This sharp internal ridge is 6 centimetres long and parallel to the external outline. In this region of the bone the anterior face is convex from within outward, while in length there is a very slight convexity. The posterior aspect is flattened.

Distally for a length of fully 3 centimetres the bone is compressed from within outward. Anteriorly something of the distal termination may be lost, but the mass preserved extends posteriorly for 9.3 centimetres, with a perfectly straight flat base, which is 1.5 centimetres wide in front, and narrows posteriorly to a few millimetres. A median groove deepening in front extends along the anterior end of the base for 3.5 centimetres. The lateral surfaces of this posterior keel are slightly concave; they converge upward to a sharp keel, which has a gently convex contour, as it tapers posteriorly to a blunt point; its depth near the shaft is 2 centimetres.

Both the pubic bones are slightly displaced distally, where they unite with this keel, and these junctions, which are not quite symmetrical, have been regarded by Sir R. Owen as sutures. The point is difficult. The anterior extremity of the bone was certainly cartilaginous, and the anterior extremities of the pubes are exposed, distinct from each other, and distinct from the keel; but this is hardly conclusive evidence of separate ossification, which is not improbable. Proximally a small fragment of a thinner bone is seen, posterior in position, which may have belonged to the ischium.

The only animals with which this form of pubis can be compared have been described by Prof. Marsh as *Cœlurus*, with which genus Prof. Marsh identifies the specimen now described*. So far as I can judge from the figures given by Marsh, it is simply proved to be closely related to *Allosaurus*, *Cœlurus*, and *Ceratosaurus*, and

* American Journal of Science, vol. xxvii. p. 335 (April 1884).

though I may think the resemblance strongest with *Cœlurus* and *Allosaurus*, it may be equally strong with *Ceratosaurus*. But when Prof. Marsh refers pelvic structures so similar as the pubes of *Allosaurus* and *Ceratosaurus* to distinct suborders of the Dinosauria, I can only conclude, if these references are correctly made and sustained, that the pubis is not always a bone on which a generic identification can be based, especially when it is imperfect proximally. I should not thus have ventured to question Prof. Marsh's reference of this pubis to a genus of his own creation were it not that there is what I regard as strong ground for believing that the sacrum associated with the pubis, no less than the dorsal vertebra figured by Sir R. Owen, belong to a genus which can be but distantly related to *Cœlurus*.

Sir R. Owen, in representing the vertical section of the dorsal vertebra, shows that the centrum is formed of the same kind of tissue, and ossified in the same way as the vertebræ of Dinosaurs in general, except that a fusiform longitudinal space is enclosed which gives no indication of being pneumatic, and appears to open into the neural canal. Now, in *Cœlurus*, Prof. Marsh has defined a genus which, in the construction of its axial skeleton, can only be compared to Ornithosaurs, having the bones invested with a thin film of bone-tissue of uniform thickness and distinctive peculiar texture. This character is as well demonstrated in Marsh's section of a dorsal vertebra as in the cervical region. Therefore the dorsal vertebræ of *Aristosuchus* cannot be referred to *Cœlurus*. Moreover the mode of attachment of the ribs is dissimilar. And hence I submit, as the sacrum of *Cœlurus* is unknown, there is no reason to suppose that it would be at all like the sacrum of *Aristosuchus*, which I now describe.

There are five vertebræ in the sacrum completely anchylosed together by their neural arches (fig. 13), and either anchylosed or in process of anchylosis by their centnums. Sir R. Owen regards the two posterior vertebræ as sacral, and the three anterior vertebræ as lumbar. Here the difference of interpretation must be adjusted by the definition of the sacrum which is adopted. If the sacral vertebræ are those from which strong sacral ribs are given off for support of the ilium, then no doubt only two such vertebræ can be counted, and the other three vertebræ in which the ilium is more or less supported on transverse processes given off from the neural arch may be termed sacro-lumbar vertebræ. This, however, involves theoretical considerations which cannot be demonstrated, for it is impossible to say how many sacral nerves united into a sacral plexus. And as all the transverse processes have the same transverse development (fig. 13, *t*), and the anchylosis of the vertebræ shows that they took part in supporting the body, I adhere to the old nomenclature, and regard all the vertebræ which supported the ilium as sacral. I believe the anterior vertebræ also contributed to support the pelvic bones, though their share in the work was less than that of the last two.

There is a fundamental difference in the plan of structure of the

sacrum and that of most other British Wealden reptiles; for while the transverse processes or sacral ribs in *Iguanodon*, *Hylæosaurus*, *Megalosaurus*, &c. are given off at the junction of the centrums, the transverse processes are here, as Sir R. Owen's figure shows, given off from the individual vertebræ to which they belong (fig. 14), as in the American genera described by Marsh, such as *Morosaurus*, *Apatosaurus*, *Atlantosaurus*, *Stegosaurus*, *Brontosaurus*, &c., and as in *Omosaurus*.

The five sacral vertebræ measure 12 centimetres. The first two (fig. 14, 1, 2) are very slightly longer than the succeeding three. The bodies of the vertebræ are constricted from side to side, so that though the flat transversely ovate articular face of the first vertebra measures 2·2 centimetres wide by 1·8 centimetre deep, the transverse measurement through the middle of the centrum is only 7 or 8 millimetres. The form of the centrum is thus almost Teleosaurian in its constriction. The second centrum has a slight tendency to be flattened on the ventral side, which is less marked in the third, while the fourth appears to carry a slight median ridge. The parallel ligamentous striations seen on the anterior border of the first vertebra are necessarily absent from the subcrenulate junctions of the succeeding vertebræ.

The neural spine is very thin and is broken away in every specimen (fig. 13, *ns*), so that the greatest height from the base of the centrum, as preserved, is only 3·5 centimetres. The third and fourth vertebræ develop additional lateral spines, one on each side of the median vertical neural spine, and these spinous processes directed outward and upward, termed metapophyses (fig. 13, *m*), correspond to those seen in the lumbar and caudal vertebræ of many mammals and the sacrum of *Megalosaurus*. Metapophyses are indicated on the second vertebra by long blunt ridges, and on the fifth vertebra by short ridges which are almost tubercles.

The transverse process from the first sacral vertebra (fig. 14, 1) is given off from the sides of the neural arch, and is directed obliquely upward and backward, terminating outward in a narrow vertically compressed process of a wedge shape, constricted in the middle, flattened behind, sharp in front, concave below, and convex above, with a strong tubercle in the middle of the upper surface.

The transverse measurement between the extremities of the processes is 33 millimetres. The antero-posterior extension of the process along its outer border is 12 millimetres, and the corresponding measurement at the middle of the constriction of its sides is 7 millimetres.

The transverse process of the second vertebra is in the anterior half of the vertebra, has a strong base posteriorly, and forms a vertically elongated, somewhat flattened, articulated surface, which is 1·9 centimetre deep in front, where the vertical border is concave, and 1·1 centimetre deep behind, so that the upper and lower surfaces converge posteriorly (fig. 14, 2). Its antero-posterior extent is 1 centimetre. The articular surface is irregular in contour, well defined, and does not extend to quite the same upward elevation as

the first process. Its upper aspect is angular, with an oblique ridge extending outward and forward to its superior angle.

The transverse process of the third vertebra is on a level with the neural canal and has a strong base. It is 12 or 13 millimetres long, is in the middle of the length of the vertebra, and forms a vertically compressed lamina (fig. 14, 3). It is slightly convex below and flattened above, with a sharp ridge on its anterior margin, which extends obliquely inward and backward, and ascends the side of the metapophysis, inclined obliquely backward.

In the fourth vertebra the transverse process is much stronger. It arises from the anterior half of the centrum, and like the process from the preceding vertebra is partly on the centrum and partly on the neural arch. It is elongated in the antero-posterior direction, subreniform on the articular facet, which is expanded, and flattened and convex below, 17 millimetres long, about 8 millimetres deep behind, and less in front (fig. 14, 4). A strong transverse ridge on the hinder part of the upper surface defines an anterior concave area, and ascends the middle of the metapophysis. The transverse measurement between the facets for the ilia, as in the previous vertebra, is about 3 centimetres.

The process on the fifth vertebra is of about the same length. Its antero-posterior extent, 17 millimetres, is slightly greater, but it is less deep. It is flattened on the underside. The outline of the facet for the ilium is subtriangular, owing to the very strong development of the ridge on its upper surface. This ridge extends obliquely forward so as to define an anterior concave cup-like depression, and a posterior oblique area on which is a tubercle which represents the metapophysis. On this vertebra the facets of the postzygapophyses are developed (fig. 14, *pz*). The transverse measurement over them is 12 millimetres; they are divided posteriorly by a deep vertical furrow which ascends the neural spine so far as it is preserved. They have the usual ovate form, and look obliquely downward and outward. Only the margin of the posterior surface of the centrum is exposed.

The outlets for the sacral nerves are through round foramina, situate between the centrum and the neural arch, at the junction of two vertebræ (fig. 14, *f*). They are seen on the left side in the second vertebra, and on the right side in the third and fifth.

The half of the dorsal vertebra preserved has the centrum 2 centimetres long at the base and 2·2 centimetres long on the neural canal, and this indicates that the back was arched. The articular ends of the centrum are very slightly concave, with a ligamentous marking at the external border. The middle of the centrum is constricted and rounded at the base. The transverse process is thin and given off above the neural canal. From the neural platform an anterior ridge descends almost vertically, and another ridge descends obliquely behind it. The height of the platform from the base of the centrum is 2·3 centimetres. The height of the centrum is 1·4 centimetre.

Only a fragment of a caudal vertebra is preserved. It is similar in form to that figured by Sir R. Owen, and similar to that attri-

buted by Marsh to *Cœlurus*, and is similarly hollow. What is the evidence of its association with the other remains cannot now be determined. The bone has a well-marked basal canal, defined at its extremity by the relatively large confluent facets for the chevron bones, which, subtracting from the quadrate end of the bone, convert it into a transversely ovate articulation.

I conclude that this animal is distinct from every British Dinosaur, but that it is nearly related to some imperfectly known types, described by Prof. Marsh, like *Allosaurus*. But what the nature of that relation may be must remain undetermined until more is known of the American Dinosauria.

EXPLANATION OF FIGURES.

PLATE XII.

(The figures are of the natural size.)

- Fig. 13. Neural aspect of sacrum of *Aristosuchus*, showing the transverse processes, metapophyses, and neural spines: *ns*, neural spine; *m*, metapophyses; *t, t*, transverse processes; *pz*, postzygapophysis.
14. Lateral view of sacrum and pubes, showing their association: *f*, foramen of sacral nerve; *p*, pubic bones; *pz*, postzygapophysis.

DISCUSSION.

The PRESIDENT said that valuable work was being done by Prof. Seeley in reexamining forms long since described, and comparing them with the more recent American discoveries.

Mr. HULKE had known the specimen for a long time, even before it was described by Prof. Owen. He quite agreed that the specimen had nothing to do with *Poikilopleuron*. He thought the three anterior vertebræ were different from the two posterior, and doubted if the first three were sacral. The first transverse process appeared to him longer than the others. The question as to whether the remains were Crocodylian or Dinosaurian was intimately connected with this identification of the vertebræ. There was also a question as to whether the bones referred by Prof. Seeley to the pubis had the form of symphyseal union assigned to them. He preferred suspending his judgment for the present.

Prof. SEELEY, in reply, said he thought if the specimen had been before the Society there would not appear to be much difference between his views and Mr. Hulke's. He showed that the last vertebra preserved was the posterior sacral vertebra because the postzygapophyses were preserved, whilst the first three of the five had approximately the same transverse measurement as the last two. No doubt the transverse processes differ, but this is the case in other Dinosaurs. It was quite possible that the pubic bones had the keel separately ossified; but he thought there could be no doubt as to the osteological identification.

21. *On the CORRELATION of the UPPER JURASSIC ROCKS of the SWISS JURA with those of ENGLAND.* By THOMAS ROBERTS, Esq., M.A., F.G.S., Woodwardian Museum, Cambridge. (Read January 26, 1887.)

IN the summer of 1884 the author was sent out by the University of Cambridge, with a grant from the Worts Fund, to study the Jurassic rocks of the Jura. He was accompanied by Mr. E. W. Small, M.A., Christ's College. Some of the results then obtained are given in the present paper.

The Jura range of mountains is formed in great part of rocks of Jurassic age, which have been thrown into a series of folds running more or less parallel to each other in a north-east and south-west direction. These folds are usually quite simple, and it only rarely occurs that the foldings have gone on to such an extent that the beds are inverted.

If one examines a geological map of the district, it will be seen that the surface of the ground is occupied principally by Upper Jurassic Rocks; indeed all the higher ground is so formed, and it is only in the valleys and gorges which run transversely across the folds, or in the centre of the folds where the upper portion has been removed by denudation, that older beds are seen.

In this paper it is proposed to deal only with the Upper Jurassic Rocks. In this term are included all the beds which lie between the base of the Callovian and the summit of the Purbeckian, and as such it is generally understood by English geologists. This classification, however, differs from that given by many foreign authors, since what is here included in the Upper Jurassic is equivalent to their Middle and Upper Jurassic.

It is proposed to give, first of all, a general description of these rocks as seen in the district visited, and then to attempt their correlation with the Upper Jurassics of England. The Jura itself has been fully described by Swiss geologists and others, and the following memoirs refer more particularly to the geology of the portion of the Jura with which it is proposed to deal:—

- (1) GREPPIN, J. B. *Essai géologique sur le Jura suisse.* Delémont, 1867.
- (2) GREPPIN, J. B. *Matériaux pour la Carte Géologique de la Suisse (Jura Bernois et districts adjacents).* Berne, 1870.
- (3) JACCARD, A. *Matériaux pour la Carte Géologique de la Suisse (Jura Vaudois et Neuchâtelois).* Berne, 1869.
- (4) DESOR and GRESSLY. *Etudes Géologiques sur le Jura Neuchâtelois.*

A complete list of papers on the geology of the central part of the Jura is given by Jaccard (*op. cit.* p. 331).

Since the publication of Oppel's work 'Die Jura Formation' in 1856-58, but little has been done towards the correlation of the Jurassic beds of the Jura with those of England, and since that time many new discoveries have been made both in England and in the Jura, which tend to make the task of correlation somewhat more easy.

The district visited is included in the cantons Berne, Neuchâtel, and Vaud; and as the rocks in the north part of the Jura differ considerably from their equivalents in the central Jura, we may conveniently divide the area into two parts, a northern and a southern. The northern district contains the greater part of the Jura Bernois, its southern boundary being a line running east and west through St. Imier. The southern district includes the remaining portion of the Jura Bernois, together with the whole of the Neuchâtelois and Vaudois.

Before commencing the description of the geology of the above districts, it is necessary to state that much valuable assistance was received from the following geologists, who accompanied us on most of the excursions made in their respective districts, and to whom the success of our expedition was in great measure due:—

M. Mathey, at Delémont; Prof. Koby, at Porrentruy; Prof. Rollier, at St. Imier; Prof. Jaccard, at Locle and Neuchâtel; Prof. Golliez, at Ste. Croix.

I have also to thank Prof. Renevier of Lausanne for a letter of introduction to the above-named gentlemen; and to Prof. Hughes I am indebted for much help and advice.

1. THE NORTHERN OR BERNOIS DISTRICT.

The geology of the Jura Bernois has been fully described by Greppin in the works already referred to (1 and 2), and there is a geological map of the district by the same author. He gives ('Jura Bernois,' &c. p. 210) the following classification of the upper series of the Jurassic Rocks:—

	I. Purbeckien.
	II. Portlandien.
	III. Virgulien.
Jura blanc ou Supérieur	IV. Kimméridgien (or Ptérocérien).
	V. Séquanien (or Astartien).
	VI. Rauracien (or Corallien).
Jura Moyen	I. Oxfordien.
	II. Callovien.
Jura ^l Brun	Bathonien, &c.

As already stated, the group of rocks with which it is proposed to deal is included in the above "Jura Supérieur" and "Moyen."

The "Callovien," the lowermost division of the upper Jurassics, is subdivided into:—

2. Le fer sous-oxfordien.

1. La zone à *Ammonites macrocephalus*.

The opinion of the Swiss geologists is not unanimous as to the true position of these beds. Greppin states (*op. cit.*) that in the

north-east part of the district these beds immediately overlie the *Calcaire roux sableux*, and in the south-west region the *Dalle nacrée*, both of which are included in the Bathonian. They are overlain in the southern chains by the *Calcaire à Scyphies inférieur*, and in the northern chains by the *Couche marneuse à Cidaris læviuscula*, *i. e.* Oxfordian. M. Mathey considers that the *Dalle nacrée* overlies the *Zone à Ammonites macrocephalus*. ("Coupes Géologiques des Tunnels du Doubs," extr. from Denkschriften d. Schweiz. Gesellsch. f. d. ges. Naturw. Band xxix. pp. 7 and 15.) Choffat supports the same view (Esquisse du Callovien et de l'Oxfordien, pp. 19, 20). He would also exclude the Callovian from the Jura supérieur (Jornal de Sciencias Mathematicas, &c. no. xl., 1885), an opinion which is controverted by Neumayr (Neues Jahrb. f. Mineral. Geol. &c., 1884, pp. 227–230). The most generally accepted view, however, appears to be that which is adopted by Greppin.

The *Zone of A. macrocephalus*, both by its fauna and petrological characters, is easily recognized. It is described as a rough, red, grey, or blackish limestone, alternating with clays of the same colour, and having a thickness of from 3 to 6 feet.

The exposures in it are not numerous, since it usually forms low ground. A small section was seen on the roadside above Montmelon, showing the following beds:—

1. Oolithe corallien.
2. Terrain à chailles.
3. Oxfordien.
4. (Nothing seen; probably occupied by the clayey portion of the Callovien.)
5. Callovien, a coarse oolitic ferruginous limestone with fossils.

The beds immediately overlying and underlying the Callovian were not shown.

A rock possessing the same lithological characters as the above-mentioned Callovian was pointed out to us by M. Mathey, amongst the material obtained from the Glovelier tunnel, where these beds were cut through.

The following fossils were obtained by us from these two localities:—

Callovian Fossils.

	Montmelon.	Glovelier Tunnel.
<i>Belemnites hastatus</i> , <i>Blainv.</i>	*	
<i>Ammonites hecticus</i> , <i>Rein.</i>	*	*
— <i>anceps</i> , <i>Rein.</i>	*
— <i>tumidus</i> , <i>Rein.</i>	*	
— <i>convolutus</i> , <i>Quenst.</i>	*	*
— <i>Bakeriæ</i> , <i>Sow.</i>	*	
— <i>Gowerianus</i> , <i>Sow.?</i>	*	
<i>Turbo bijugatus</i> , <i>Quenst.</i>	*	
<i>Terebratula dorsoplicata</i> , <i>Suess</i>	*	*
<i>Rhynchonella</i> , <i>sp.</i>	*

The *fer sous-oxfordien* includes the zone of *Ammonites athleta*, *A. ornatus*, and the clays with pyritous fossils. The lower part of the substage is formed of grey or brown calcareous clays, enclosing numerous ferruginous oolitic grains; its upper part consists of blue or black clays containing crystals of selenite and pyritized fossils. Its thickness is estimated at from 3 to 6 feet.

The clays form low ground, and sections in them are rare. The dark clays with pyritous fossils were seen at the river-side, a short distance east of Soyhière, and they also occur at Châtillon. Similar beds, but considerably thicker, are exposed in the Combe Chavatte, below Caquerelle, and they were also seen as far south as Le Cernil, north of Tramelan.

The clays in the upper part of this substage are precisely similar, both in their lithological character and their fossils, to the Oxford Clay of England.

The following fossils were obtained from the localities given below. It must be remembered, however, that this does not represent the whole fauna of these clays, but only the fossils collected by us or presented to us by the geologists named in the introduction.

Fossils from "le fer sous-oxfordien".

	Glovelier Tunnel.	Châtillon.	Combe Chavatte.	Soyhière.	Le Cernil.
<i>Belemnites hastatus</i> , <i>Blainv.</i>	*	..	*	*	*
— <i>Owenii</i> , <i>Pratt</i>	*	
<i>Ammonites Mariæ</i> , <i>D'Orb.</i>	*	*	..	*	
— <i>Lamberti</i> , <i>Sow.</i>	*	*	*		
— <i>Eugenii</i> , <i>Rasp.</i>	*	*	
— <i>hecticus</i> , <i>Rein.</i>	*	*	*	*	*
— <i>lunula</i> , <i>Rein.</i>	*				
— <i>crenatus</i> , <i>Brug.</i>	*	..	*		
— <i>Babeanus</i> , <i>D'Orb.</i>	*	*	*	*	
— <i>sulciferus</i> , <i>Opp.</i>	*	*	*	*
— <i>convolutus</i> , <i>Quenst.</i>	*	*	*		
<i>Nucula elliptica</i> , <i>Phil.</i>	*	*	
<i>Leda Diana</i> , <i>D'Orb.</i>	*		
— <i>lachryma</i> , <i>Quenst.</i>	*	
<i>Pleurotomaria Munsteri</i> , <i>Röm.</i>	*				
<i>Turbo Meriani</i> , <i>Goldf.</i>	*				
<i>Alaria bispinosa</i> , <i>Phil.</i>	*			
<i>Cucullæa concinna</i> , <i>Morr. & Lyc.</i>	*	..	*		
<i>Pentacrinus pentagonalis</i> , <i>Goldf.</i>	*	..	*		
<i>Terebratula impressa</i> , <i>v. Buch</i>	*	..	*		
<i>Rhynchonella Thurmanni</i> , <i>Voltz</i>	*	..	*		

The *Oxfordian* rocks always occupy low fertile ground, and present quite a contrast to the features produced by the overlying beds, which usually stand out in bold relief, forming ridges supporting a meagre vegetation. The hollows or valleys in which the Oxfor-

dian beds lie are known as 'Combes Oxfordiennes.' The rocks of this stage are divisible into:—

2. Le Terrain à chailles marno-calcaire.

1. Le Calcaire à Scyphies inférieur*.

In the northern part of the Jura, the lower part of the Oxfordian is seen overlying the *Marnes à fossiles pyriteux* as a grey or black clay, fairly fossiliferous. The typical locality for this substage is Hobel, south of Basle, and Greppin gives a list of fossils from this place (*op. cit.* p. 63).

The *Terrain à chailles marno-calcaire* is composed of yellowish-grey clays, alternating with limestones of the same colour, and containing *sphérites* or *chailles*.

In the gorge at Thiergarten, near Delémont, the upper Jurassics are cut through, and here, underlying the 'Terrain à chailles siliceux,' about 110 feet of Oxfordian are exposed, consisting of alternations of bluish clays and limestones.

They are also seen in the quarry south-east of Liesberg (see section fig. 1, p. 234) as yellowish limestone separated by sandy clays of the same colour, passing up into bluish clays with thin limestones. Similar beds also crop out below the 'Terrain à chailles siliceux,' south of St. Ursanne station.

In the 'Combe Chavatte,' the Oxfordian is from 100 to 130 feet thick, and consists of bluish marly clays with intermediate beds of limestone; some of the latter are fairly thick and regular, whilst others are nodular. These beds are seen lying between the Clay with pyritous fossils and the 'Terrain à chailles siliceux,' and these yielded the following fossils:—

Pholadomya exaltata, *Ag.*
— *paucicosta*, *Ag.*

Pleuromya varians, *Ag.*
Rhynchonella Thurmanni, *Voltz.*

Further south, at Paturale and Le Cernil (north of Tramelan), above the Clays with pyritous fossils, come grey marly beds containing nodules of impure limestones, from which the following fossils were obtained:—

Ammonites cordatus, *Sow.*
— *convolutus*, *Quenst.*
— *sulciferus*, *Opp.*
— *hecticus*, *Rein.*
— *perarmatus*, *Sow.*
Pleurotomaria Munsteri, *Röm.*
Astarte robusta, *Lyc.*
Modiola bipartita, *Sow.*

Trigonia perlata, *Ag.*
Lima subantiquata, *Röm.*
— *duplicata*, *Sow.*
Pholadomya exaltata, *Ag.*
— *concinna*, *Ag.*
Terebratula insignis, *Schüb.*
— *bisuffarcinata*, *Schl.*

The *Corallian* has been divided by Thurmann into three substages, and this classification is adopted by Greppin:—

3. Le Calcaire à Nérinées.

2. Oolithe Corallienne.

1. Terrain à chailles siliceux †.

* Greppin, in his 'Essai' &c., includes this substage in the 'Callovien.'

† Greppin, in 1867, included this in the 'Oxfordien.'

The *Terrain à chailles siliceux* is somewhat variable in character, but is usually composed of hard, compact limestones, often siliceous and separated by clayey beds; its upper part is often oolitic. Disseminated through the series are numerous nodules, which are usually siliceous, and the fossils are sometimes silicified.

The following sections, amongst others, were observed in the rocks of this substage. At Thiergarten, near the south end of the gorge, the 'Terrain à chailles siliceux' is seen to consist of coarse bluish limestone with clayey partings; some of the limestone bands are nodular, and the whole thickness of the series is about 98 feet.

Fig. 1.—Section in Quarry near Roadside, south-east of Liesberg.

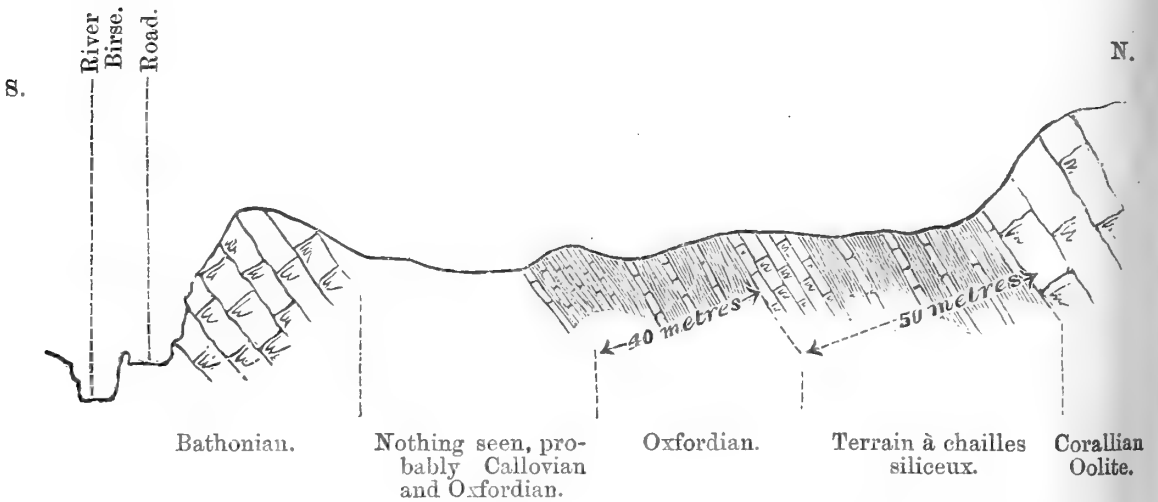

A better section is shown in the quarry south-east of Liesberg (fig. 1). Overlying the Oxfordian are some thin beds of yellowish limestone, succeeded by greyish limestone separated by bands of dark clays, the whole being about 160 feet thick. These beds are worked for hydraulic lime and are very fossiliferous.

Similar beds were seen above Montmelon, and again on the east and west side of St. Ursanne station.

At the 'Combe Chavatte,' further to the west, these beds are more siliceous and contain silicified fossils.

At Pichoux and again at Gobat the 'Terrain à chailles siliceux' is said to be wanting unless represented by some limestones three metres thick, which form the uppermost part of the Oxfordian (Greppin, *op. cit.* p. 66).

The following fossils were obtained from rocks of this substage:—

	<i>Locality.</i>
Belemnites hastatus, <i>Blainv.</i>	} Liesberg.
Ammonites cordatus, <i>Sow.</i>	
— convolutus, <i>Quenst.</i>	
— hecticus, <i>Rein.</i>	
Pleurotomaria Munsteri, <i>Röm.</i>	
Phasianella striata, <i>Sow.</i>	
Chemnitzia heddingtonensis, <i>Sow.</i>	
Natica clymenia, <i>d'Orb.</i>	
Pholadomya paucicosta, <i>Ag.</i>	

	<i>Locality.</i>	
Pholadomya concinna, <i>Ag.</i>	} Liesberg.	
— læviuscula, <i>Ag.</i>		
Lima pectiniformis, <i>Schl.</i>		
Plicatula semiarmata, <i>Et.</i>		
Modiola imbricata, <i>Sow.</i>		
Cardium intextum, <i>Münst.</i>		
Pecten globosus, <i>Quenst.</i>		} St. Ursanne Tunnel.
— inæquicostatus, <i>Phil.</i>		
— articulatus, <i>Schl.</i>		
Rhynchonella Thurmanni, <i>Voltz.</i>		} Liesberg.
— lacunosa, <i>Schl.</i>		
Terebratula insignis, <i>Schüb.</i>		
— delemontana, <i>Opp.</i>		
Waldheimia bucculenta, <i>Sow.</i>		
Cidaris florigemma, <i>Phil.</i>		
Hemicidaris crenularis, <i>Ag.</i>		
Pseudodiadema aroviense, <i>Et.</i>		
Glypticus hieroglyphicus, <i>Ag.</i>		
Collyrites ringens, <i>Ag.</i>		
— bicordata, <i>Des.</i>	} Thiergarten.	
Millericrinus echinatus, <i>Quenst.</i>		
Apocrinus polycyphus, <i>Th. et Et.</i>		
Thecosmilia annularis, <i>Flem.</i>	} Liesberg.	
Isastrea explanata, <i>Goldf.</i>		

Oolithe Corallienne and *Calcaire à Nérinées*.—Passing up from the bluish limestones and clays of the ‘Terrain à chailles siliceux,’ we come to a grey or white oolitic limestone, which usually contains numerous fragments of shells and corals; the whole is from 16 to 33 feet thick. This constitutes the *Oolithe Corallienne*. Overlying it is the *Calcaire à Nérinées*, a rock somewhat variable in character, but always composed of limestones, which may be compact in texture, whilst at other times they are chalky, tuffaceous, and quite soft; its thickness varies from 60 to 270 feet.

These Corallian rocks are more easily denuded than the overlying Astartian; consequently, in the escarpments, where both are seen, the Corallian beds are always weathered out into hollows and caverns, whilst the overlying strata project as overhanging ledges; in this way, the beds are easily recognized.

A good section of the Corallian, Astartian, and Pterocerian is seen on the roadside at Vorbourg, near Delémont. Aided by M. Mathey, we were able to work out almost every bed in the above stages. The section in the Corallian here is as follows, the beds being given in descending order:—

	ft.
8. Compact, fine-grained limestone	22
7. Compact, thick-bedded limestones, with <i>Nerinea</i> .	18
6. Thin-bedded, coarse, subcrystalline, and pisolitic limestones.....	4
5. Compact limestone.....	15
4. Thick-bedded, white limestone, with corals, <i>Diceras</i> , &c.	18
3. Irregularly bedded whitish limestone	14
2. Thick limestones, sometimes oolitic.....	17
1. Greyish oolitic limestone	32

The 'Terrains à chailles siliceux,' which should come below, are not now exposed.

This section is also described by Greppin (*op. cit.* p. 87), but we could not make our measurements quite agree with those published, especially in the upper part of the series.

At the roadside east of Soyhière a quarry is opened in the uppermost division of the Corallian; the rock is a whitish limestone, part of which is hard, but the greater portion is quite soft and tuffaceous, and the whole rock is largely made up of corals.

These beds are also seen at Thiergarten, Courrendlin, and again near Roche, and also at Montmelon. Just behind the station, at St. Ursanne, is a thick series of white limestone; its lower part is somewhat oolitic, but higher up it is quite tuffaceous and contains numerous Gasteropods. A little further to the east, at the west end of the bridge which spans the valley, and apparently somewhat lower in the series, a similar tuffaceous limestone occurs crowded with *Diceras*. Then, again, in the railway-cutting on the eastern side of the valley, still lower beds are seen overlying the 'Terrain à chailles siliceux' as a well-bedded, coarse, oolitic limestone. We have therefore here nearly a complete section in the Corallian between the 'Terrain à chailles siliceux' and the Astartian, and in it the following beds are recognized, in descending order:—

4. Tuffaceous limestones crowded with Gasteropods.
3. Oolitic limestones.
2. Tuffaceous limestone with *Diceras*.
1. Oolitic limestone.

Further west, at Caquerelle, these Corallian beds occur as a white oolitic limestone, which has yielded a large number of corals.

The fossils obtained from the *Oolithe Corallienne* and *Calcaire à Nérinées* are given in the accompanying list.

Fossils from the 'Oolithe Corallienne' and 'Calcaire à Nérinées.'

	St. Ursanne.	Caquerelle.	Soyhière.	Vorbourg.	Liesberg.	Develier-dessus.	Thiergarten.
<i>Purpura Lapierrera, Buv.</i>	*						
<i>Cerithium corallense, Buv.</i>	*						
— <i>buccinodeum, Buv.</i>	*						
— <i>cf. muricatum, Sow.</i>	*	*			
<i>Nerinea speciosa, Voltz</i>	*						
— <i>nodosa, Voltz</i>	*						
— <i>elegans, Thurm.</i>	*						
— <i>Defrancei, Desh.</i>	*	*	..	*			
— <i>bruntrutana, Thurm.</i>	*	*					
— <i>ursicina, Thurm.</i>	*					
— <i>Rœmeri, Philippi</i>	*						
<i>Nerita canalifera, Buv.</i>	*						

Fossils from the 'Oolithe Corallienne' and 'Calcaire à Nérinées'
(continued).

	St. Ursanne.	Caquerelle.	Vorbourg.	Liesberg.	Develier- dessus.	Thiergarten.
<i>Nerita sigaretina</i> , <i>Buv.</i>	*					
<i>Turbo tegulatus</i> , <i>Münst.</i>	*					
<i>Trochus angulatoplicatus</i> , <i>Münst.</i>	*					
<i>Pileopsis</i> , <i>sp.</i>	*					
<i>Patella</i> , <i>sp.</i>	*					
<i>Cardium corallium</i> , <i>Leym.</i>	*					
<i>Diceras arietinum</i> , <i>Lam.</i>	*	..	*			
<i>Lithodomus socialis</i> , <i>Thurm.</i>	*					
<i>Terebratula insignis</i> , <i>Schübl.</i>	*	*		
— <i>moravica</i> , <i>Glöck.</i>	*			
— <i>Bauhini</i> , <i>Et.</i>	*					
<i>Pygaster tenuis</i> , <i>Ag.</i>	*	
<i>Stylina tubulifera</i> , <i>Phil.</i>	*	*			
— <i>Girodi</i> , <i>Et.</i>	*			
<i>Thecosmilia crassa</i> , <i>d'Orb.</i>	*					
— <i>laxata</i> , <i>Et.</i>	*			
— <i>dichotoma</i> , <i>Koby</i>	*			
<i>Rhabdophyllia flabellum</i> , <i>Et.</i>	*
<i>Isastrea explanata</i> , <i>Goldf.</i>	*			
— <i>Thurmanni</i> , <i>Et.</i>	*			
<i>Thamnarea arborescens</i> , <i>Et.</i>	*				
<i>Thamnastrea concinna</i> , <i>Goldf.</i>	*			
<i>Convexastrea</i> , <i>sp.</i>	*				
<i>Cryptocœnia limbata</i> , <i>Goldf.</i>	*			
— <i>decipiens</i> , <i>Et.</i>	*				
— <i>iocœnia corallina</i> , <i>Koby</i>	*				
<i>Stylosmilia Michelini</i> , <i>Edw.</i>	*				
<i>Calamophyllia flabellum</i> , <i>Blainv.</i>	*				
<i>Dendrohelium coalescens</i> , <i>Goldf.</i>	*				
<i>Epismilia multisepta</i> , <i>Koby</i>	*				
— <i>delemontana</i> , <i>Koby</i>	*				
— <i>magna</i> , <i>Koby</i>	*				

The *Sequanian* or *Astartian* consists of a greyish, compact, and often oolitic limestone, with some marly beds. A very constant fossiliferous marly zone occurs about the middle of the series.

The section at Vorbourg, where the whole of the *Astartian* is seen, is as follows, commencing at the summit:—

	ft.	in.
16. Thinly bedded limestones	1	0
15. Thick grey limestones	14	0
14. Limestones similar to 16.....	1	6
13. Thick limestone	3	0
13 a. Ditto	4	0
12. Thin limestones	8	0
11. Irregularly bedded limestones	13	0
10. Irregular limestones.....	30	0
9. Thick, whitish, oolitic limestones	34	0

	ft.	n.
8. Brecciated limestones	4	0
7. Thick limestones, slightly oolitic	14	0
6. Reddish, oolitic limestones	12	0
5. Compact, oolitic limestone	19	0
4. Well-bedded, reddish limestone, very compact...	15	0
3. Grey limestones	22	0
2. Thin-bedded limestones, marly at base and crowded with fossils	30	0
1. Oolitic limestones.....	28	0

(Below this the section was not well exposed.)

At Angolat, about three quarters of a mile west of Soyhière, there is a good section in the marls and also in the beds immediately overlying and underlying them. They are also exposed at Montchaibeut, Thiergarten, and Bassecourt; and Astartian limestones are also seen above the Corallian at St. Ursanne.

The Astartian is largely quarried at Laufon, where the limestones are for the most part oolitic; fossils are not abundant in these beds.

The fossils in the accompanying list were principally obtained from the marls.

Astartian Fossils.

	Angolat.	Laufon.	Montchaibeut.	Vorbourg.	W. of Glovelier.	Bressancourt.	Soyhière.
<i>Belemnites astartinus, Et.</i>	*						
<i>Natica turbiniformis, Röm.</i>	*						
— <i>hemisphærica, Röm.</i>	*					
<i>Phasianella striata, Sow.</i>	*						
<i>Nerinea Gosæ, Röm.</i>	*		
<i>Pholadomya complanata, Röm.</i>	*						
— <i>paucicosta, Ag.</i>	*						
<i>Cyprina tenuirostris, Et.</i>	*	*			
<i>Cardium fontanum, Et.</i>	*	*
<i>Trigonia suprajurensis, Ag.</i>	*					
<i>Mytilus longævus, Et.</i>	*						
<i>Lima astartina, Th.</i>	*	..	*				
<i>Pecten lens, Sow.</i>	*						
<i>Ostrea sequana, Th.</i>	*						
<i>Exogyra nana, Sow.</i>	*	..	*				
<i>Terebratula humeralis, Röm.</i>	*	..	*	*			
— <i>Bauhini, Et.</i>	*						
— <i>suprajurensis, Thurm.</i>	*	
— <i>moravica, Glöck.</i>	*						
<i>Rhynchonella inconstans, Sow.</i>	*	*	*	..	*	
— <i>helvetica, d' Orb.</i>	*						
<i>Cidaris florigemma, Phil.</i>	*						
<i>Hemidiadema stramonium, Ag.</i> (Cour- rendlin.)							
<i>Pseudodiadema neglectum, Thurm.</i> ...	*						
<i>Pedina sublævis, Ag.</i> (Rebeuvelier.)							
<i>Apiocrinus Meriani, Des.</i>	*			

Pterocerian or *Kimeridgian*.—The classical locality for this stage is Banné, near Porrentruy, where it has been known and worked for many years. Its lithological character is very constant in the district, being composed of well-bedded limestones usually very fine in texture and light coloured; there are also some thin beds of marl present, and these are usually very fossiliferous. The limestones are much quarried for building-purposes.

The quarries at Delémont are opened in rocks belonging to this stage, and here the following section was observed:—

Compact grey limestones	} 34 feet.
Fossiliferous marly bed.....	
Thick-bedded limestones	
Compact limestone	

Most of the fossils obtained in this locality come from the marls, because, as a general rule, the compact limestones are not fossiliferous, and when they are so, it is almost impossible to get the fossils out in a determinable condition.

The section at Vorbourg, in the *Pterocerian*, shows compact limestones of much the same character as the beds in the quarries below, and described in the above section.

At Glovelier similar beds were also seen; and in a small exposure at the roadside, a little to the west of the village, the surface of one of the limestone beds is exposed, which is crowded with *Pteroceras*, &c.

Limestones like those of Delémont were seen at Courrendlin and also at Vermes; but in the last-named locality the beds were somewhat nodular.

In the neighbourhood of Porrentruy these beds have been, as already stated, largely worked. They are also quarried a little to the north of Villars, where about 20 feet of the limestones are shown, the uppermost part being fossiliferous.

The fossiliferous *Pterocerian* marls are also exposed at the roadside between Fontenois and Bressancourt, and again at Courgenay. In both these localities the rock is crowded with fossils.

Subjoined is a list of the fossils, which come chiefly from the marls:—

Pterocerian Fossils.

	Delémont.	Fontenois.	Courgenay.	Glovelier.
<i>Nautilus Marcouanus</i> , <i>D'Orb.</i>	*	
<i>Natica gigas</i> , <i>Br.</i>	*	...	*	
— <i>hemisphærica</i> , <i>D'Orb.</i>	*			
<i>Pteroceras oceani</i> , <i>Delab.</i>	*	*	*	*
<i>Rostellaria Wagneri</i> , <i>Thurm.</i>	*	*	
<i>Pholadomya myacina</i> , <i>Ag.</i>	*	
— <i>Protei</i> , <i>Ag.</i>	*	*	*	
— <i>multicosta</i> , <i>Ag.</i>	*

Pterocerian Fossils (continued).

	Delémont.	Fontenois.	Courgenay.	Glovelier.
<i>Pholadomya recurva</i> , <i>Ag.</i>	*	
— <i>paucicosta</i> , <i>Ag.</i>	*			
<i>Thracia incerta</i> , <i>Thurm.</i>	*	
<i>Ceromya excentrica</i> , <i>Ag.</i>	*	...	*	*
<i>Lucina substriata</i> , <i>Röm.</i>	*	...	*	
<i>Cardium bannesianum</i> , <i>Thurm.</i>	*	*	*
— <i>axino-obliquum</i> , <i>Thurm.</i> (<i>cf. dis-</i> <i>simile</i>)	*	
<i>Trigonia muricata</i> , <i>Röm.</i>	*	
<i>Mytilus jurensis</i> , <i>Mer.</i>	*
— <i>subpectinatus</i> , <i>D' Orb.</i>	*			
<i>Modiola subæquiplicata</i> , <i>Goldf.</i>	*	...	*	
<i>Trichites</i> , <i>sp.</i>	*	
<i>Gervillia tetragona</i> , <i>Röm.</i>	*	
<i>Avicula Gessneri</i> , <i>Thurm.</i>	*	
<i>Lima spectabilis</i> , <i>Contj.</i>	*			
<i>Hinnites inæquistriatus</i> , <i>D' Orb.</i>	*	*	*	*
<i>Ostrea semisolitaria</i> , <i>Et.</i>	*	*	*	*
<i>Terebratula subsella</i> , <i>D' Orb.</i>	*	*	...	*
— <i>humeralis</i> , <i>Röm.</i>	*			
<i>Rhynchonella inconstans</i> , <i>Sow.</i>	*		
— <i>semi-inconstans</i> , <i>Et.</i>	*			
<i>Cidaris florigemma</i> , <i>Phil.</i>	*			
<i>Hemicidaris Thurmanni</i> , <i>Ag.</i>	*	*	...	*
<i>Acosalenia aspera</i> , <i>Ag.</i>	*			
<i>Holcypus Meriani</i> , <i>Desk.</i>	*			

Virgulian.—The rocks of this stage occur only in the western and southern portions of the district, its eastern boundary being a sinuous line running from Soleure to Seprais (Jura Bernois). Greppin (*op. cit.* p. 115) points out that the northern part of the Jura was undergoing upheaval during Pterocerian times, and that land existed in the north-eastern portion of the district under consideration at the time when the Virgulian beds were being deposited; in this way he accounts for the absence of rocks of this stage in the north-east Jura.

The Virgulian was at one time well exposed in the neighbourhood of Porrentruy; at present, however, the quarries are filled up and no section is visible. A section in these beds at Pichoux is described as follows (Greppin, *op. cit.* p. 116):—

Whitish limestones	feet. 65
Yellowish or grey clays and shelly limestones with <i>Exogyra virgula</i>	19½
Thick beds of hard compact limestone	65

Fragments of Virgulian were seen on the surface at Waldeck, near Porrentruy; they consisted of a reddish-brown limestone with

Exogyra virgula. Further south, at Tramelan, a small exposure was observed in these beds, which consisted of yellowish marls and impure limestones largely made up of the shells of *Exogyra virgula*.

The *Portlandian* beds, which are so well developed in our southern district, are almost wanting in the northern part of the Jura. The only locality where they were seen in the latter district is north of the railway-station at Moutier. The same remarks apply equally well to the *Purbeckian*, as apparently they have not been found further north than Moutier; and there, overlying the *Portlandian*, is a dark-coloured limestone, about one foot thick, containing numerous freshwater fossils. In the absence of fossils it is hard to define the limit between the *Purbeckian* and *Portlandian* in this section (see fig. 2).

Fig. 2.—Section in Railway-cutting north of Moutier Station.

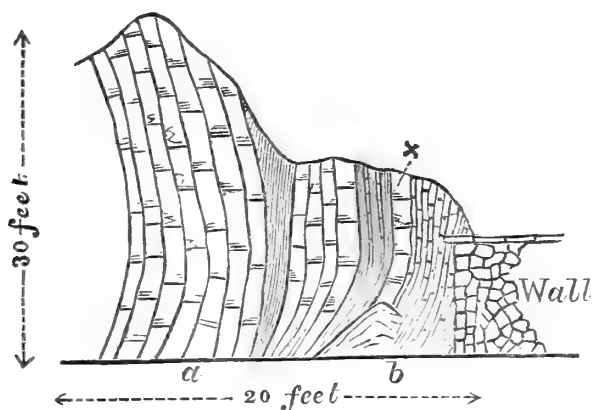

a, *Portlandian*; b, *Purbeckian*.

The bed marked × contains freshwater fossils (*Purbeckian*).

The following fossils were obtained from the black limestone referred to above:—

- | | |
|-------------------------------------|------------------------------------|
| Chara Jaccardi, <i>Heer</i> . | Planorbis Choffati, <i>Maill</i> . |
| Cypris valdensis, <i>Sow. (?)</i> . | Corbula Forbesi, <i>De Lor</i> . |
| Bithynia, sp. | Hydrobia Choparti, <i>Sandb</i> . |

2. THE SOUTHERN DISTRICT.

Nearly the whole of this district is described in Prof. Jaccard's Memoir on the Cantons Neuchâtel and Vaud, and the following classification is taken from his 'coupe théorique,' pl. 4, at the end of the work referred to:—

- | | | | | | | | | | |
|---|---|---|--|---|--|-------------------------------|--|--|--|
| Groupe Jurassique Supérieur,
or <i>Kimméridien</i> | {
4. <i>Purbeckien</i> .
3. <i>Portlandien</i> or <i>Nérinéen</i> .
2. <i>Ptérocérien</i> .
1. <i>Astartien</i> . | } | | | | | | | |
| | | | | Groupe Jurassique Moyen, or
<i>Oxfordien</i> | {
4. <i>Corallien</i> .
3. <i>Pholadomien</i>
2. <i>Spongitién</i>
1. <i>Callovien</i> . | } <i>Oxfordien Calcaire</i> . | | | |
| | | | | | | | | | |
| | | | | | | | | | |

The *Callovian* presents but a feeble development in this district, as compared with that of the northern area. The *fer sous-oxfordien*, which is so constant in the latter, is scarcely, if at all, represented in the southern district. Its total thickness does not exceed 16 feet, and it is usually considerably less. It is, however, possible to distinguish two zones in it:—

2. *An upper one*, composed of grey clay, poor in fossils, and sometimes containing pyrites.
1. *A lower limestone*, which is ferruginous and rich in fossils.

In the 'Combe Grède,' near St. Imier, a somewhat peculiar development of the *Callovian* is seen; it consists of a bed of greyish chert 8 inches thick. The underlying *Dalle nacrée*, however, is very well developed here, and may, in part, represent the *Callovian* of other areas.

A better exposure of it is shown in the eastern side of the quarry at Pouillerel, near Chaux-de-Fonds, where the following section was observed:—

1. Oxfordien.
2. Callovien, 10 ft. $\left\{ \begin{array}{l} b. \text{ Blue sandy clays with fossils.} \\ \text{thick} \dots\dots\dots a. \text{ Thin band of ferruginous marl.} \end{array} \right.$
3. *Dalle nacrée*.

A thicker development of the ferruginous marl occurs in a quarry a little further north, and consists of a brown limestone and marls with ferruginous oolitic grains. The following fossils were obtained from this bed:—

<p><i>Belemnites hastatus</i>, <i>Blainv.</i> <i>Ammonites hecticus</i>, <i>Rein.</i> — convolutus, <i>Quenst.</i> — athleta, <i>Phil.</i> <i>Nucula ornata</i>, <i>Quenst.</i></p>	}	<p><i>Lima rigida</i>, <i>Sow.?</i> <i>Hinnites abjectus</i>, <i>Mor. & Lyc.</i> <i>Terebratula dorsoplicata</i>, <i>Suess.</i> <i>Collyrites ellipticus</i>, <i>Ag.</i> <i>Holcetypus</i>, sp.</p>
---	---	---

The *Callovian* was also seen below the 'Spongitiën' on the roadside opposite Brenets, as a clayey bed with *Belemnites hastatus*, *Ammonites convolutus*, and *A. hecticus*.

The *Oxfordien Calcaire* is divided by Jaccard into:—

2. Pholadomien.
1. Spongitiën.

The 'Spongitiën' is composed of alternations of limestones and clays, having a total thickness of about 15 metres (49 feet). In some localities these beds contain numerous sponges; in others, again, such fossils are either absent altogether or very rare.

In the 'Combe Grède' this lower division of the *Oxfordian* consists of grey compact limestones with some marly beds in its upper part. Further west, near the railway-station at Convers, the 'Spongitiën' is worked for cement; the beds exposed in the quarries are thin-bedded, grey, argillaceous limestone with partings of clay.

Overlying the *Callovian*, in the quarry at Pouillerel, referred to above, about 10 feet of *Oxfordian* are exposed, of much the same

character as in the localities named above. The beds contain numerous crinoid stems and some sponges.

On the roadside opposite Brenets the whole of the 'Spongitiën' is seen as in the following section:—

Pholadomien	ft.
	30
Spongitiën ... { Well-bedded thick limestone, 15 ft. }	} 29
{ Limestone with shaly particles, 14 ft..... }	
Callovien	5
Dalle nacrée	10 seen.

The '*Pholadomien*' is somewhat variable in this district. In the 'Combe Grêde' these beds are very thick and are made up of:—

3. A series of thin-bedded limestones, sometimes nodular, with partings of shale.
2. Thick series of bluish shales, poor in fossils.
1. Thin limestones and shales similar to (3).

In the section opposite Brenets, mentioned above, the Pholadomian is 30 feet thick, and consists of thin limestones with partings of clay of about equal thickness.

The upper beds of this substage have been worked for cement at Les Praises, West of Ste. Croix, and here they consist of nodular, grey, argillaceous limestones. The lower part is more marly. Similar beds were also seen at Les Auges.

The following fossils were obtained from the Oxfordian in the southern district:—

	<i>Localities.</i>
Ammonites convolutus, <i>Quenst.</i> ...	La Vraconne, St. Sulpice, Les Auges, and Combe Grêde.
— hecticus, <i>Rein.</i>	Combe Grêde.
Belemnites hastatus, <i>Blainv.</i>	Combe Denayriez.
Pleuromya varians, <i>Ag.</i>	Ditto.
— Voltzii, <i>Ag.</i>	Ditto.
Pholadomya scutata, <i>Ag.</i>	North of Ste. Croix.
— cingulata, <i>Ag.</i>	Combe Denayriez.
— exaltata, <i>Ag.</i>	Ditto.
Anatina undulata, <i>Phill.</i>	Ditto.
Modiola bipartita, <i>Sow.</i>	Ditto.
Goniomya proboscidea, <i>Ag.</i>	Ditto.
Astarte robusta, <i>Et.</i>	Les Auges.
Nucula ornata, <i>Quenst.</i>	Ditto.
Terebratula orbis, <i>Quenst.</i>	Combe Denayriez.
— bisuffarcinata, <i>Schl.</i>	Ditto.
Collyrites, sp.	Ditto.

The *Corallian* is much less developed in the southern district than in the northern, and, indeed, appears to be represented by a series of beds which correspond only to the *Terrain à Chailles siliceux* of the northern district.

The stage is described (Jaccard, *op. cit.* p. 201) as consisting of:—

3. A dark blue clay, which underlies the Astartian.
2. Reddish-brown limestone, poor in fossils, passing down into a series of thin-bedded limestones, which are very fossiliferous.
1. Barren clays.

They do not, however, present the same lithological character throughout the district.

In the 'Combe Grêde' the lower beds of the Corallian are represented by limestones containing *Rhynchonella inconstans*, *Terebratula insignis*, *Cidaris*, &c., and above these come some greyish compact limestones, containing species of *Cidaris* and *Hemicidaris*.

In the *débris* thrown out from the Loges tunnel, in which the Corallian beds are pierced, the rock pointed out to us as belonging to this horizon is composed of brown and some grey argillaceous limestones, rich in fossils; the following is a list of the principal ones obtained by us:—

Turbo Meriani, <i>Goldf.</i>	Terebratula Bauhini, <i>Et.</i>
Lima rigida, <i>Sow.</i>	Rhynchonella pinguis, <i>Op.</i>
— Renevieri, <i>Et.</i> (<i>cf. grandis</i> ,	Cidaris florigemma, <i>Phil.</i>
<i>Röm.</i>).	Stomechinus perlatus, <i>Ag.</i>
Pecten lens, <i>Sow.</i>	Glypticus hieroglyphicus, <i>Ag.</i>
Ostrea solitaria, <i>Sow.</i>	

The *Astartian* is divided into two substages—an *upper*, calcareous, and a *lower* argillaceous one. The general character of the former is thick-bedded homogeneous limestone, although at times it is oolitic. The oolitic portion of these beds is usually fossiliferous, but the fine-grained limestones rarely contain fossils. The lower or argillaceous division of the *Astartian* near Locle is 50 metres (164 feet) thick, and consists of clays and limestones varying in character and thickness; the limestone is sometimes oolitic and marly, whilst the clays are at times quite arenaceous. In the upper part of this substage there is a fossiliferous zone with *Terebratula humeralis*; and lower down there is another marly bed containing this same fossil in abundance. Both of these fossiliferous marly beds are seen near the summit of Mount Chasseral, and again further north, on the other side of the St. Imier valley.

On the roadside opposite Brenets the following section in the lower beds of the *Astartian* was observed:—

	ft.
5. Well-bedded greyish limestones.....	12
4. Marls, with some thin beds of limestone containing <i>Melania striata</i>	10
3. Greyish limestone.....	20
2. Alternations of limestone and marls.....	8
1. Greyish limestones.....	5 seen.

The marls with *Terebratula humeralis* also occur in the railway-cutting near Noiraigue.

In the neighbourhood of Ste. Croix the *Astartian* is composed of a compact reddish limestone, which is well seen on the roadside to the north-west of that town.

The following fossils come from the marly beds near the summit of the Chasseral:—

Chemnitzia heddingtonensis, <i>Sow.</i>	Terebratula suprajurensis, <i>Ag.</i>
Trigonia subconcentrica, <i>Et.</i>	Cidaris florigemma, <i>Phil.</i>
Terebratula humeralis, <i>Röm.</i>	Hemicidaris, sp.

The *Pterocerian* is, perhaps, the most important stage in the whole Upper Jurassic series, since it forms by far the greater portion of the high ground in this part of the Jura. Its thickness has been estimated at 150 metres (492 feet), and it would appear as if it was thickest in the southern part of the Jura, and thins out to the north. On the whole, it presents much the same lithological character in the district under consideration, but most of the beds are poor in fossils. It has been divided into an *upper* and *lower* substage.

The *Lower Pterocerian* consists of a thick series of coarse greyish limestones with some marls, the whole being usually poor in fossils. The following zones have been made out in the *Upper Pterocerian* (Jaccard, *op. cit.* p. 189):—

3. Very compact lithographic limestones with Bryozoa.
2. White saccharoid or crystalline limestone with Bryozoa, *Nerinea* and *Diceras* (small).
1. Greyish marls, rich in fossils.

In the 'Combe Grède' the following section was observed below the Virgolian:—

3. A thick series of greyish limestones.
2. Greyish, somewhat brecciated limestones, with *Terebratula subsella*, *Ostrea solitaria*, *Nerinea bruntrutana*, &c.
1. Limestones with *Nerinea*.

Similar massive limestones were seen near La Baume, Locle. North of the road-tunnel, near Noirvaux-dessous, on the way to Ste. Croix, a fossiliferous marly band in the Pterocerian is exposed, and overlying it come some well-bedded, grey, very compact limestones. Further south, near Jougne, the Pterocerian is quarried, and the section shows about 24 feet of grey, very compact limestones, with some brownish marly beds. Rocks of this age are also worked near Soleure, and the fossils obtained from the quarries at St. Nicholas (north of Soleure) include remains of Turtles and other Reptiles and of fish.

The following section was seen in one of the three quarries at St. Nicholas:—

- | | |
|--|-----|
| | ft. |
| 4. Hard and somewhat porous limestone | 5 |
| 3. Greenish marls, with <i>Pteroceras</i> , <i>Nerinea</i> , <i>Terebratula</i> , <i>Hemicidaris</i> , &c. | 4 |
| 2. Hard, grey, compact limestone, separated by a thin marly bed from (1) | 7 |
| 1. Thick bed of compact grey limestone. | |

The other two quarries are opened in rocks having the same lithological character as that at the base of the above section.

The following fossils were obtained from the Pterocerian beds at the localities named below:—

Pterocerian Fossils.

	Combe Grède.	Va Bechaz.	Noirvaux- dessous.	Jougne.
<i>Natica gigas</i> , <i>Br.</i>	*
<i>Chemnitzia Bronni</i> , <i>D'Orb.</i>	*
<i>Nerinæa Elsгаudiæ</i> , <i>Thurm.</i>	*
— <i>bruntrutana</i> , <i>Thurm.</i>	*			
<i>Pteroceras oceani</i> , <i>Delab.</i>	*	*
<i>Pholadomya Protei</i> , <i>Ag.</i>	*	*	
— <i>multicosta</i> , <i>Ag.</i>	*	
— <i>helvetica</i> , <i>Desh.</i>	*
<i>Homomya hortulana</i> , <i>D'Orb.</i>	*		
<i>Pleuromya donacina</i> , <i>Ag.</i>	*
<i>Ceromya excentrica</i> , <i>Et.</i>	*	*	*
— <i>inflata</i> , <i>Ag.</i>	*	
<i>Astarte subclathrata</i> , <i>Thurm.</i>	*
<i>Lucina rugosa</i> , <i>Röm.</i>	*
<i>Cardium bannesianum</i> , <i>Thurm.</i>	*	...	*
<i>Diceras suprajurense</i> , <i>Thurm.</i>	*
<i>Trigonia suprajurenensis</i> , <i>Ag.</i>	*	
<i>Modiola subæquiplicata</i> , <i>Goldf.</i>	*		
— <i>perplicata</i> , <i>Goldf.</i>	*
— <i>jurensis</i> , <i>Mer.</i>	*		
<i>Pinna monsbeliardiana</i> , <i>Contj.</i>	*	
<i>Pecten Benedicti</i> , <i>Contj.</i>	*	
<i>Hinnites inæquistriatus</i> , <i>Voltz</i>	*	*	*	*
<i>Ostrea semisolitaria</i> , <i>Et.</i>	*	*	*	*
<i>Terebratula subsella</i> , <i>D'Orb.</i>	*	*	*	*
<i>Hemicidaris Thurmanni</i> , <i>Ag.</i>	*	...	
<i>Isastrea oblonga</i> , <i>Flem.</i>	*	

The *Virgulian* is exposed in the 'Combe Grède' as a thick series of greyish, compact limestones, with some marly beds. At Brenets there is at the base of the Portlandian a marly bed which has yielded *Exogyra virgula*. Further south, owing to the absence of this fossil, it has not been recognized with certainty, although the marly bed, which is more or less persistent at the base of the Portlandian, may probably represent it in part, at least. According to Jaccard, however, the *Virgulian* is said to be wanting, and the term "Portlandien" is used by him to include all the beds between the base of the Purbeckian and the top of the Pterocerian in the Jura Vaudois and Neuchâtelais.

The *lower* division of the *Portlandian* consists of massive grey and compact limestones, which are largely quarried. Towards the base these beds are lighter in colour and become marly. Fossils are never abundant in these rocks, but they nevertheless contain fragments of teeth, scales, and bones of fish and other vertebrates.

The *upper Portlandian* is largely made up of massive limestones, which are often dolomitic, and distributed throughout it are beds of

marl, varying in thickness; the fossils from these beds come principally from the marls.

In the neighbourhood of Brenets and Villers-le-Lac there are several sections in the rocks of this stage. Near Brenets it is seen as a thin-bedded, grey limestone, interbedded with fossiliferous marly beds. Then, again, both sides of the Lac-des-Brenets are formed of these Portlandian limestones, and in this locality present a striking resemblance to the Mountain Limestone in some of the Yorkshire dales. Similar limestones are also seen below the Purbeckian beyond Locle, and the whole series is well exposed in the gorge leading from Neuchâtel towards Valangin, where the following section was observed:—

6. Thick series of thin-bedded, compact, grey limestones.
5. Thick, compact, grey limestones.
4. Thin marly bed.
3. Gray and compact limestones.
2. Marly bed.
1. Thick series of dark-grey limestones.

The *Purbeckian* of the Jura has attracted considerable attention, and has been fully described by Jaccard and De Loriol, and again by Maillard. Jaccard (*op. cit.* p. 176) makes out three subdivisions in this stage:—

An *upper* grey, oolitic and fissile marl, about $\frac{1}{2}$ metre (20 inches) thick, containing brackish-water fossils. This bed occurs at Villers-le-Lac, and also on the road to Valangin, near Neuchâtel. In the last-named locality it is represented by a marly bed, which contains numerous scales of fish. This forms a passage into the overlying Valangian, and below it come some more thin-bedded marls and limestones, with freshwater fossils. At Villers-le-Lac these beds contain numerous *Chara*-spores.

The *middle Purbeckian* is much more variable than the preceding. Below the freshwater marls and limestones there is a fairly constant bed of very porous and almost scoriaceous limestone, which passes down into clayey beds containing numerous small bipyramidal quartz-crystals, and carbonaceous material is sometimes present, as are also crystals of gypsum.

The *lower Purbeckian* consists principally of limestones, and in it the following zones have been made out:—

3. Limestone of scoriaceous texture (*Dolomie celluleuse*), 13 to 16 feet.
2. White, and sometimes oolitic, limestone (*Dolomie saccharoïde*), with *Cardium villerense* and *Corbula inflexa*, 6 feet 6 inches.
1. Fissile, thinly laminated limestones, 34 feet.

None of the sections observed by us in this district showed these three substages, and in most cases only a small exposure was visible. At St. Imier greyish marly limestones with *Limnæa* and *Planorbis* were seen belonging to this stage. The section at Villers-le-Lac, which is perhaps the most typical for the Purbeckian in the Jura, was, at the time of our visit, almost completely hidden by débris; we saw some thin grey limestones and marls with fossils, and below these came clays with gypsum, and there were numerous small crystals

of quartz scattered about the surface of the ground, which had been washed out of the clay. The clayey beds with carbonaceous material and gypsum were seen in the railway-cutting near Locle.

Marly beds of Purbeckian age were also observed north of Ste. Croix; and further south, near Vallorbes, the following section occurs:—

3. Valangian.
2. Purbeckian:—
 - (d) Vesicular and some compact limestones.
 - (c) Compact grey limestone.
 - (b) Scoriaceous limestone.
 - (a) Grey marls.
1. Portlandian.

The section on the road towards Valangin, already referred to, was also visited; and here again the succession was not clear, but the beds of Purbeckian age which were seen consisted of grey limestones and marls.

The Purbeckian of the Jura is said to be conformable to the Portlandian beds below, and to pass up without any physical break into overlying Valangian; and our own observations support this view.

From the description of the beds in the two districts under consideration it will be seen that the various stages differ considerably in their lithological character and, to some extent, in their fossil contents. On account of these differences it is not always easy to correlate exactly the beds in these two parts of the Jura. In the accompanying Table (p. 249) a correlation is given which is probably approximately correct.

In both areas we find the Callovian underlain by the 'Dalle nacrée.' The Callovian itself is, as already stated, but feebly represented in the southern district, and the *Fer sous-oxfordien*, so well marked in the northern parts of the Jura, is scarcely represented in the Central Jura, unless it be by the clayey bed in the upper part of the Callovian, which sometimes contains pyritous nodules.

In the 'Combe Grêde,' near St. Imier, where the Callovian consists of a thin cherty band, the Callovian of the northern district may be represented in part by the uppermost portion of the 'Dalle nacrée.'

The Oxfordian presents much the same palæontological character in both districts, and the correlation indicated in the table is, as far as can be gathered from the study of the fossils, correct.

The Corallian of the southern district, according to Desor and Gressly ('*Etudes Géol. sur le Jura Neuchâtelois*, p. 75), represents only the *Terrain à chailles siliceux* of the Northern Jura, and they are of opinion that the *Oolithe corallienne* and *Calcaire à Nérinées* are wanting in the Jura Neuchâtelois. About 50 per cent. of the fossils from the Corallian of the Central Jura are found in the *Terrain à chailles siliceux*, whilst only about 8 species (out of 54) occur in the *Oolithe corallienne* of the Northern Jura, and most of these appear also in the *Terrain à chailles siliceux*. It is highly probable therefore that the correlation given by Desor and Gressly is correct. If this be the case, the question arises whether any part of the Astartian of the southern district is the equivalent of the *Calcaire*

à *Nérinées* and *Oolithe corallienne*. From an analysis of the fossils it appears that of the 62 species recorded (Jaccard, *op. cit.* p. 199) from the Astartian marls of the south district, 35 occur in the same beds in the northern district, whilst 8 only have been found in the *Calcaire à Nérinées*, and 3 of these range up into the Astartian. There are therefore only 5 species which connect the *Calcaire à Nérinées* with the lower division of the Astartian in the Central Jura. From these considerations it seems probable that these Astartian beds represent palæontologically but little, if any, of the upper portion of the Corallian in the northern Jura.

Table of Correlations of the Upper Jurassic in the North and Central Jura.

NORTHERN DISTRICT.		SOUTHERN DISTRICT.	
Purbeckian.		Purbeckian.	
-----		-----	
Portlandian.		Portlandian.	
-----		-----	
Virgulian.		-----	
-----		-----	
Pterocerian.		Pterocerian.	
-----		-----	
Astartian.		Astartian.	
-----		-----	
Corallian.	Calcaire à Nérinées.	-----	-----
	Oolithe Corallienne.		
	Terrain à chailles siliceux.		
-----		-----	
Oxfordian.	Terrain à chailles mar-no-calcaire.	-----	Pholadomian.
	Calcaire à Scyphies inférieur.		
-----		-----	
Callovian.	Le Fer sous-oxfordien.	-----	Supérieur.
	Zone of <i>Am. macrocephalus</i> .		
-----		-----	
Sathonian.	Dalle nacrée, &c.	Dalle nacrée.	

Correlation of English and Swiss Upper Jurassic Deposits, according to Oppel.

Zones.	Yorkshire.	South-west England.	Swiss Jura.
Purbeck-schichten.		Purbeck Beds.	Marnes de Villars. 36
Zone of <i>Trigonia gibbosa</i> .		Portland Stone.	Portlandien. 35
Zone of <i>Pteroceras oceani</i> .		Kimeridge Clay.	Pterocerien. 34
Subzone of <i>Astarte supracorallina</i> .	Kimeridge Clay.		Astartien. 33
Zone of <i>Diceras arietinum</i> .	? Upper Calcareous Grit.	? Upper Calcareous Grit.	Coral Rag and Nerineenschichten with <i>Diceras arietinum</i> . 32
Zone of <i>Cidaris florigena</i> .	Coral Rag and Coralline Oolite.	Coral Rag.	Terrain à chailles siliceux. 31
Lower Calcareous Grit. Scyphiakalk.	Lower Calcareous Grit.	Lower Calcareous Grit.	Scyphienkalk. 30
Zone of <i>Amm. biarmatus</i> .	Oxford Clay.	Oxford Clay.	Blue clays with pyritous fossils. 29
Zone of <i>Amm. athleta</i> .		Laminated clays with <i>Amm. ornatus</i> .	Grey Clay and Brown Oolite with <i>Amm. anceps</i> , &c. 28
Zone of <i>Amm. anceps</i> .	Kelloway Rock.		27
Zone of <i>Amm. macrocephalus</i> .		Kelloway Stone.	<i>Ammonites-macrocephalus</i> Beds. 26

The Astartian beds in the two districts have many characters in common, and are approximately on the same horizon; and the same may be said of the Pterocerian, except that the latter is considerably thicker in the southern district.

It has already been pointed out that the Virgolian is hardly represented in the southern district, unless it be by the marly bed at the base of the Portlandian.

The two remaining stages, the Portlandian and Purbeckian, are found principally in our southern district, and those recorded from the one locality, Moutier, in the northern district are probably on the same horizon as those similarly named in the southern district.

3. CORRELATION.

When the Upper Jurassic rocks of the Jura are compared with those of England, one cannot fail to notice the marked dissimilarity which occurs in their lithological character; and this is best shown in the upper part of the series, which, in England, consists of the thick clays of Kimeridge and the more variable Portland and Purbecks, whilst in the Jura they are formed of massive limestones. There is, however, a strong resemblance in some of the lower beds in the two areas, and indeed some of them are almost identical in their lithological character. The difference in the nature of the rocks is, of course, accompanied by a difference in their fauna; and on this account it will not, in all cases, be easy to establish the true synchronism of the stages in the two countries. Certain well-marked zones are present in both areas, and these are of great service in working out the correlation of the remaining zones.

Oppel, in his 'Jura-formation Englands, Frankreichs und des südwestlichen Deutschlands,' correlates the English Upper Jurassics with those of the Swiss Jura as in the accompanying table, p. 250 (extracted from his table no. 64).

The classification employed by Oppel differs somewhat from that which is adopted in this paper. His zone 34 includes the Virgolian and Pterocerian of later writers; zone 32 is the 'Oolithe corallienne' and the 'Calcaire à Nérinées;' zone 30 is the Oxfordian; and the zones 26-29 (inclusive) represent the Callovian, of which 27, 28, and 29 are the 'Fer sous-oxfordien.'

In the years 1857-60, Marcou's 'Lettres sur les Roches du Jura,' &c., appeared, and in them he attempted, amongst other things, a correlation of the Jurassic beds of the Franche-comté with those of England, and also refers to the same beds in the Jura. The only beds which he correlates with certainty are included in his *Groupe corallien*, which he makes the equivalent of the Coralline-oolite Group of Phillips. All his other correlations are queried (see his table, p. 101).

Waagen, in 1865, in his 'Versuch einer allgemeinen Classification der Schichten des oberen Jura' (table, p. 30), gives the following correlations of the English and Swiss beds. In the fourth column the classification adopted in this paper has been added.

Correlation of English and Swiss Upper Jurassic Deposits, according to Waagen (1865).

Zones.	England.	South-east France and West Switzerland.	Classification adopted.
Portland Kalk or zone of <i>Trigonia gibbosa</i> .	Portland Stone. Portland Sand.	Dolomite of Neuchâtel.	Portlandian.
Horizon of the Solenhofen Slates.	Upper Kimeridge.	Nerineen-Kalke of the Canton Neuchâtel.	
Zone of <i>Pteroceras oceanii</i> and <i>Amm. mutabilis</i> .	Middle Kimeridge.	Etage Virgulien and Etage Strombien to Pterocerien.	Virgulian. Pterocerien.
Astarte Kalke and zone of <i>Amm. tenuilobatus</i> .	Lower Kimeridge.	Astartien.	Astartian.
Zone of <i>Amm. binammatius</i> and <i>Cidaris florigemma</i> .	Upper Calcareous Grit. Oxford Oolite.	Corallien. White Oolite, with <i>Nerinea</i> and <i>Cid. florigemma</i> . Terrain à Chailles.	Corallian.
Zone of <i>Amm. transversarius</i> and <i>A. Martelli</i> .	Lower Calcareous Grit.	Argovien.	Oxfordian.
Zone of <i>Ammonites biarmatus</i> .	Oxford Clay	Oxford Clay.	Le fer sous-oxfordien

Prof. Blake, referring to Waagen's classification of the British Jurassics, states that he can only make out a two-fold division of the Kimeridge Clay—an *upper*, which agrees with that of Waagen, and a *lower*, which includes the Middle and part of the Lower Kimeridge of Waagen; whilst the remainder of the Lower Kimeridge, together with a portion of the underlying zone of *Cid. florigemma*, Blake includes in his Kimeridge Passage-beds (Q. J. G. S. vol. xxxi. p. 197).

The following table is taken from Renevier's "Tableaux des Terrains sédimentaires" (tab. no. 5, Bull. Soc. Vaud. vol. xiii.) :—

ENGLAND.	JURA OCCIDENTAL.
Purbeck Beds. Dirt Bed of Portland.	Marnes à <i>Planorbis Loryi</i> . Marnes à Gypse. Calc. dolomitique à <i>Corbula inflexa</i> .
-----	-----
Portland Stone. Portland Sand. Upper Kimeridge.	Calcaire Portlandien.
-----	-----
Kimeridge Clay à <i>Exogyra virgula</i> .	Marnes à <i>Ostrea virgula</i> (Virgulien inférieur). Ptérocérien.
-----	-----
Upper Calc Grit et Coral Rag (pars). ?	Astartien compacte, &c. Astartien marneux.
-----	-----
Coralline oolite à <i>Lima rigida</i> ; et Bancs. à <i>Cidaris florigemma</i> .	Oolithe corallienne à <i>Nérinées</i> et <i>Diceras arietina</i> , et Calcaires chailleux.
-----	-----
	Terrain à chailles à <i>Glypticus hieroglyphicus</i> .
-----	-----
Calc Grit à <i>Ostrea dilatata</i> .	Oxfordien { Pholadomien. Calcaire. { Calc. hydraulique. Spongilien.
-----	-----
Oxford-clay à <i>Amm. Dun-cani</i> .	Marne Oxfordienne à fossiles pyriteux.
-----	-----
Kelloway-rock à <i>Amm. cal-loviensis</i> .	Kellovien ferrugineux à <i>Amm. anceps</i> et <i>Amm. macrocephalus</i> .
-----	-----

In the subjoined table an attempt has been made to show the correlations of the authors referred to above, and it will be seen that they differ in several important points.

Correlation of views of different Authors.

		English equivalents according to		
	Swiss Jura.	Oppel.	Waagen.	Renévier.
	Purbeckien.	Purbeck Beds.		Purbeck Beds.
	Portlandien.	Portland Stone.	Portland Stone. Portland Sand. Upper Kimeridge.	Portland Stone. Portland Sand. Upper Kimeridge.
	Virgulien.			
	Ptérocérien.	Kimeridge Clay.	Middle Kimeridge.	Lower Kimeridge.
	Astartien.		Lower Kimeridge.	
Corallien.	Calcaire à Nérinées. Oolithe Corallienne.	? Upper Calcareous Grit.	Upper Calcareous Grit and Oxford Oolite.	Corallian (excluding the Lower Calcareous Grit).
	Terrain à Chailles siliceux.	Coral Rag.		
	Oxfordien.	Lower Calcareous Grit.	Lower Calcareous Grit.	Calcareous Grit with <i>Ostrea dilatata</i> .
Callovien.	Fer sous-oxfordien.	Oxford Clay.	Oxford Clay.	Oxford Clay.
	Zone of <i>Amm. macrocephalus</i> .	Kelloway Rock.		Kelloway Rock.

The lower division of the *Callovian*, or zone of *Ammonites macrocephalus*, as shown in the above table, is regarded by Opper and Renevier as the equivalent of the Kelloway Rock of England. It is a well-known fact that this rock is local in its development in England, and can only be regarded as the basement bed of the Oxford Clay. In Yorkshire, and again in Wiltshire, this rock contains a fairly distinct fauna. A complete list of the fossils from the Kelloway Rock of Yorkshire is given by Mr. Hudleston (Proc. Geol. Assoc. vol. iv. p. 373), and twelve of them are recorded from the *macrocephalus*-zone of the Jura. Very few of these 12 species, however, are peculiar to the Kelloway Rock, since most of them range up into the Oxford Clay. *Amm. macrocephalus* itself does not appear in Mr. Hudleston's list referred to above, although a variety is recorded from these beds (Geol. Mag. 1882, p. 147); the species is, however, recorded from the *Avicula*-shales which underlie the Kelloway Rock. These shales also contain *Avicula echinata*, *Rhynchonella concinna*?, and *Waldheimia lagenalis*, all of which are characteristic of the upper part of the Bathonian of the Jura.

Dr. Wright gives the following arrangement of the beds which come between the Oxford Clay and the Cornbrash in Wiltshire (Proc. Cotteswold Nat. Club for 1869, p. 207):—

Oxford Clay =zone of *Amm. Jason*.
 Kelloway Rock =zone of *Amm. calloviensis*.
 Kelloway Shales =zone of *Amm. macrocephalus*.
 Cornbrash.

The fossils recorded from the Cornbrash of Wiltshire (Wright, *op. cit.* p. 200) include *Pholadomya Heraulti*, *Avicula echinata*, *A. costata*, *Terebratula intermedia*, and *Rhynchonella concinna*, all of which occur in, and most of them are characteristic of, the upper beds of the Bathonian of the Jura. Of the fossils which have been collected from the Kelloway beds of this part of England (*op. cit.* pp. 208 and 209) 10 have been found in the *macrocephalus*-zone of the Jura, but only one of these, viz. *Amm. macrocephalus*, is peculiar to the Kelloway beds. Several of the *ornatus*-group of Ammonites occur in the zone of *Amm. macrocephalus* as well as in the overlying 'Fer sous-oxfordien'; similarly they appear in the Kelloway beds and in the Oxford Clay.

In the Bedfordshire district the *ornatus* Ammonites have been found low down in the Oxford Clay, and the same thing also occurs at Swindon (H. B. Woodward, Q. J. G. S. vol. xlii. p. 295).

From the above remarks, it may safely be stated that the fauna of the Cornbrash links it closely with the upper beds of the Bathonian, and that the lower division of the Callovian (zone of *Amm. macrocephalus*) is represented in England by the Kelloway Rock or, when the latter is absent, by the lower beds of the Oxford Clay.

The *fer sous-oxfordien* has many characters in common with the Oxford Clay of England. Lithologically it is almost identical, and there are several species of Ammonites common to both; and, further, these fossils are preserved under precisely similar conditions,

that is to say, they are pyritized. This sub-stage includes the zones of *Amm. biarmatus*, *A. athleta*, and *A. anceps* of Oppel, who correlates it with the Oxford Clay of S.W. England, and with the Oxford Clay and part of the Kelloway Rock of Yorkshire. Waagen and Renevier similarly place it on the horizon of the Oxford Clay.

In Yorkshire, Hudleston (*op. cit.*) makes a three-fold division of the Oxford Clays:—

3. Upper, with *Amm. perarmatus*, rarely.
2. Middle, with *Amm. Eugeniei*, *A. crenatus*, &c.
1. Lower, with *Bel. Owenii*, *Ammonites Lamberti*, *A. athleta*, *A. oculatus*, and *A. crenatus*.

Further south, in Northamptonshire and Bedfordshire, where there is but a thin development of the Kelloway Rock, the following subdivisions have been made out by Prof. Judd ("Geology of Rutland," Mem. Geol. Surv. p. 232):—

- f. Clays with *cordati* group of Ammonites.
- e. " " Ammonites of the group *ornati* and *Terebratula impressa*.
- d. Clays with *Belemnites hastatus*.
- c. " " — *Owenii*.
- b. " " *Nucula nuda*.
- a. Kelloway Sands, &c.

In the south-west of England the two zones, an upper with *cordati* and a lower with *ornati* Ammonites, have also been recognized (H. B. Woodward, Q. J. G. S. vol. xlii. p. 295).

The list of fossils from the 'Fer sous-oxfordien' of the Jura Bernois given by Greppin (*op. cit.* p. 58) contains 86 species, 26 of which occur in England at the following horizons respectively:—

- | | |
|----------------------------|--|
| 19 species in Oxford Clay. | |
| 4 " " | Lower Calcareous Grit. |
| 1 " " | Corallian. |
| 2 " " | range from Oxford Clay to Lower Calcareous Grit. |

The following fossils, amongst others, are common to the Oxford Clay and the 'Fer sous-oxfordien':—

<i>Belemnites Puzosianus</i> , <i>D'Orb.</i> <i>Ammonites crenatus</i> , <i>Brug.</i> — <i>Lamberti</i> , <i>Sow.</i> — <i>Mariae</i> , <i>D'Orb.</i> — <i>cordatus</i> , <i>Sow.</i> — <i>oculatus</i> , <i>Phil.</i>	<i>Ammonites athleta</i> , <i>Phil.</i> — <i>Henrici</i> , <i>D'Orb.</i> — <i>perarmatus</i> , <i>Sow.</i> <i>Leda (Nucula) lachryma</i> , <i>Sow.</i> <i>Terebratula impressa</i> , <i>v. Buch.</i>
---	--

It will be seen therefore that both the *cordati* and *ornati* Ammonites are well represented. In England *Amm. perarmatus* is found principally in the upper part of the Oxford Clay, but more commonly in the Lower Calcareous Grit; in the Jura it occurs in the Oxfordian as well as in the 'Fer sous-oxfordien,' and this would indicate a high position in the Oxford Clay for the 'Fer sous-oxfordien.' *Gryphaea dilatata*, our most common Upper-Oxford-Clay fossil, is, on the

other hand, absent from the 'Fer sous-oxfordien,' but is recorded from the overlying beds in the Jura. From these considerations it is clearly seen that the 'Fer sous-oxfordien' is represented by the Oxford Clay of England; but whether the former represents the whole of the latter is very difficult to decide. The 'Fer sous-oxfordien' undoubtedly contains several species which occur in our Lower and Upper Oxford Clay; but some characteristic fossils of the latter subdivision are absent, and have been found only in the beds overlying the 'Fer sous-oxfordien,' and it is quite possible that a portion of the Oxfordian beds of the Jura may be the equivalent of the upper part of the Oxford Clay of England.

In our southern district of the Jura it will be remembered that the Callovian is but feebly developed as compared with that of the northern area. Jaccard's list of fossils (*op. cit.* p. 213) from these beds includes 11 species of Ammonites (some belonging to the *cordati* and others to the *ornati* group) nearly all of which occur in the Oxford Clay of England. *Amm. macrocephalus* is not recorded, nor is *Gryphæa dilatata*. The representatives of our Kelloway Rock and Oxford Clay, or at least the greater part of them, must be found in these Callovian beds.

The fauna of the Oxfordian beds in the northern part of the Jura is fairly well marked off from the underlying Callovian, indeed it is much more closely allied to the Corallian. Out of the 154 species recorded from these beds (Greppin, *op. cit.* p. 68) 55 pass up into the 'Terrain à chailles siliceux,' whilst only 13 occur in the Callovian. Amongst the 154 species there are no less than 51 English species coming from the following horizons* :—

Lower Oolites	2 species.
Oxford Clay	3 "
Corallian (including the Lower Calcareous Grit)	23 "
Oxford Clay and Corallian	21 "
" " and Cornbrash	1 "
Kimeridge Clay	1 "
	—
	51

The species peculiar to our Oxford Clay are:—

- Ammonites crenatus, *Brug.*
- flexuosus, *Münst.*
- Terebratula impressa, *v. Buch.*

And such forms as *Amm. perarmatus*, *Amm. cordatus*, *Amm. convolutus*, and *Gryphæa dilatata* are also present, which in England range from the Oxford Clay to the Lower Calcareous Grit. The evidence derived from these fossils supports the view already expressed, that a portion of the Oxford Clay of England is on the horizon of the Oxfordian of the Jura.

* In working out the range of the English fossils the following lists have been used:—Morris's Catalogue of British Fossils; Hudleston, Proc. Geol. Assoc. vol. v. p. 481; Blake & Hudleston, Q. J. G. S. vol. for 1877; Sedgwick Essay for 1886, MS.

As stated above, there are 23 species common to the Oxfordian beds in question and the Corallian of England, and further most of the 21 species which range from the Oxford Clay to the Corallian are more characteristic of the latter than of the former. Of the 23 species which occur in the Oxfordian of the Jura and the Corallian of England, 10 are found in the Lower Calcareous Grit, 6 of which are peculiar to that horizon, and 11 out of the 21 species which range from the Oxford Clay to the Corallian have not been found above the Lower Calcareous Grit. The 6 species peculiar to the Lower Calcareous Grit are:—

Ammonites canaliculatus, *Münst.*
 — *Henrici*, *D'Orb.*
Pholadomya concinna, *Ag.*
 — *cingulata*, *Ag.*
Rhynchonella Thurmanni, *Br.*
Millericrinus echinatus, *Schl.*

The last-named species is one of the most characteristic fossils of the lower beds of the Corallian of England; in the Jura, however, it passes up from the Oxfordian into the Terrain à chailles siliceux, and the same may be said of *Rhynchonella Thurmanni*.

The fauna of the Oxfordian of the Jura has certainly a distinct Corallian *facies*, and appears to be closely allied to the lower part of the English Corallian. From palæontological considerations, therefore, this stage must be regarded as the equivalent of the Lower Calcareous Grit, together with a part of the underlying Oxford Clay.

In the southern district of the Jura, 68 species are recorded from the Spongitan (*Jaccard, op. cit. p. 209*), and 24 from the Pholadomian (*ibid. p. 207*). Nine species of the former occur in England, 7 of which are Corallian and 2 Oxford Clay. The 24 Pholadomian fossils include 4 British species, 2 coming from the Corallian and the same number from the Oxford Clay. The evidence obtained from these fossils points to much the same conclusions as those arrived at above.

The *Terrain à chailles siliceux* has yielded 178 species (*Greppin, op. cit. p. 80*); as already stated, 55 of these are common to the Oxfordian, whilst 11 pass up into the *Calcaire à Nérinées*, excluding those fossils which range up from older beds. The fossils from the 'Terrain à chailles siliceux' include 52 English species, 34 of which are exclusively Corallian, 8 range from the Oxford Clay to the Corallian, and the remaining 10 are Lower-Oolite forms. There is little doubt, therefore, that the 'Terrain à chailles siliceux' of the Jura is on the same horizon as some part of the English Corallian. The latter has been fully described by Blake and Hudleston (*Q. J. G. S. vol. xxxiii. p. 260*), and they have made out the following subdivisions of these beds (*op. cit. p. 389*):—

6. Supracoralline Beds.
5. Coral Rag.
4. Coralline Oolite.
3. Middle Calcareous Grit.
2. The Lower Limestone or Hambleton Oolite.
1. Lower Calcareous Grit.

The question arises how many of these subdivisions represent the 'Terrain à chailles siliceux.' We have already seen that the Oxfordian is on the horizon of the Lower Calcareous Grit, and some of the fossils from the 'Terrain à chailles siliceux' also connect it with the Lower beds of the Corallian, as for example:—

Gervillia aviculoides, <i>Sow.</i>	Millericrinus echinatus, <i>Schl.</i>
Waldheimia bucculenta, <i>Sow.</i>	Gryphæa dilatata, <i>Sow.</i>
Rhynchonella Thurmanni, <i>Br.</i>	Belemnites hastatus, <i>Blainv.</i>

None of these occur above the Hambleton Oolite in England. The siliceous beds in the Jura also contain:—

Ammonites plicatilis, <i>Sow.</i>	Phasianella striata, <i>Sow.</i>
Chemnitzia heddingtonensis, <i>Sow.</i>	Trigonia monilifera, <i>Ag.</i>
Ostrea duriuscula, <i>Phil.</i>	Mytilus pectinatus, <i>Sow.</i>
Lima pectiniformis, <i>Schl.</i>	Glypticus hieroglyphicus, <i>Ag.</i>
Terebratula insignis, <i>Schüb.</i>	Stomechinus gyratus, <i>Ag.</i>
Cidaris florigemma, <i>Phil.</i>	Clypeus subulatus, <i>Y. & B.</i>
Hemicidaris intermedia, <i>Flem.</i>	Montlivaltia dispar, <i>Phil.</i>

All of these are characteristic of the Coralline Oolite and Coral Rag. The sub-zone of *Cidaris florigemma* (Coral Rag) is marked in England by the abundance of this Echinoid, and it is in fact almost limited to this horizon*. In the Jura it makes its first appearance in the 'Terrain à Chailles siliceux,' and extends up to the Pterocerian; as far as was seen by us, however, it occurs abundantly only in the 'Terrain à Chailles siliceux.' *Glypticus hieroglyphicus* is also fairly common in these beds in the Jura, although it is said to range into the overlying 'Oolithe corallienne' and 'Calcaire à Nérinées'; in England it is confined to the Coral Rag. On palæontological grounds therefore the 'Terrain à Chailles siliceux,' while probably representing some portion of the lower divisions of the Corallian (*e. g.* the Hambleton Oolite), must also be regarded as the equivalent of the other subdivisions of the Corallian of England, up to and including a part at least of the Coral Rag.

It has already been shown that the Corallian of the southern district in the Jura probably represents only the 'Terrain à Chailles siliceux' of the district further north. Jaccard (*op. cit.* p. 204) gives a list of 55 species from these beds, 20 of which occur in the British Corallian, and 12 belong exclusively to the Coral Rag and Coralline Oolite. Here, again, the evidence is clearly in favour of the correlation indicated above for the 'Terrain à Chailles siliceux.'

The *Oolithe corallienne* has, as already shown, been recognized only in the northern district of the Jura, and has yielded a fauna consisting of 44 species, 10 of which occur in the Coral Rag and Coralline Oolite of England. These 10 species include—

Ammonites plicatilis, <i>Sow.</i>	Trigonia Meriani, <i>Ag.</i>
Nerinæa Rœmeri, <i>Goldf.</i>	Terebratula insignis, <i>Schüb.</i>
— visurgis, <i>Röm.</i>	Glypticus hieroglyphicus, <i>Goldf.</i>
Cerithium limæforme, <i>Röm.</i>	

* It is recorded from the Kimeridge Passage-beds by Prof. Blake.

The fauna connects these beds also with our Coral Rag, and they must be regarded as belonging to that horizon.

The 'Calcaires à Nérinées,' which are the same as the *Diceras*-beds of Oppel, are, by him, stated to be probably represented in England by part of the Kimeridge Clay, and probably also by the Upper Calcareous Grit (*op. cit.* tab. p. 805); in his tab. no. 64, however, he places them on the horizon of the Upper Calcareous Grit (?).

The list of fossils from these *Nerinea*-beds contains 192 species (Greppin, *op. cit.* p. 88), 28 of which are British; 2 only of these are restricted to our Kimeridge Clay, viz. *Turbo Julii* and *Rostellaria mosensis*, 4 are Lower-Oolite forms, whilst the remaining 22 species are Corallian. Out of these 22 species—

- 13 occur in the Coral Rag.
- 2 occur in the Coralline Oolite.
- 3 occur in the Coral Rag and Coralline Oolite.
- 4 range from Oxford Clay and Lower Calcareous Grit
- to the Coral Rag.
- 22

The Coral Rag and Coralline Oolite species include—

Nerinea Roëmeri, Goldf.
 — clymene, D'Orb.
Turbo princeps, Goldf.
Pecten qualicosta, Et.
Terebratula insignis, Schüb.
Cidaris florigemma, Phil.

Hemicidaris intermedia, Flem.
Glypticus hieroglyphicus, Goldf.
Pseudodiadema radiata, Phill.
Thecosmilia annularis, Flem.
Thamnastrea concinna, Goldf.
Stylina tubulifera, Phil.

All of them belong to our Coral-Rag fauna. It has already been stated that these *Nerinea*-limestones are, in some localities in the Jura, crowded with corals, and here they were undoubtedly the sites of old coral-reefs. Many of the corals in these reefs are similar to those which occur in rocks having much the same character in England, and which are, for the most part, of Coral-Rag age, although not exclusively so, since some are known from the Upper Calcareous Grit, as, for example, the reef at Ringstead Bay (Blake and Hudleston, Q. J. G. S. vol. xxxiii. p. 272). The most striking difference between the coral fauna of the British Corallian reefs and those of the Jura is the larger number of species in the latter. Prof. Koby informed us that about 200 species had been described from these coral-bearing beds at Caquerelle. This richer coral fauna in the Jura may be due to a more suitable climate for coral-growth having existed there than in England. Neumayr has shown that tropical conditions prevailed in the region of the Jura during Jurassic times, whilst in England the climate was more temperate. The mere presence of coral-reefs in the 'Calcaire à Nérinées' of the Jura, and in the Coral Rag of England, does not by any means prove that they are of the same age; when, however, the number of fossils, corals as well as higher forms of life, which are common to both are taken into consideration, it seems highly probable that they belong to approximately the same period. The 'Calcaire à Nérinées' contains no Upper-Calcareous-Grit and only two Kimeridge-Clay fossils, so there

is little or no evidence to show that they represent any part of our Upper Calcareous Grit or Kimeridge Clay. It is possible, and, indeed, appears to be highly probable, that the period during which coral-reefs flourished in the Jura may not have terminated at the same time as in England; if such was the case, then the coral-reef fauna would have survived as long as the physical conditions were favourable, with little or no change. That such was the case in England is shown by the fossils of the Ringstead-Bay reef, which stratigraphically comes immediately below the Kimeridge Clay, yet its fauna is precisely like that of the Coral Rag (Blake and Hudleston, Q. J. G. S. vol. xxxiii. p. 272). If the two Kimeridge-Clay species which are recorded from the 'Calcaire à Nérinées' be taken as an indication of the commencement of the introduction of the Kimeridgian fauna into the Jura, we may then regard the 'Calcaire à Nérinées' as being represented in England by a portion of our Coral Rag and the whole of the Upper Calcareous Grit, and what other evidence there is would not be opposed to such a view.

The three stages which overlie the Corallian of the Jura, viz. the Astartian, Pterocerian, and Virgulian, are closely united together, both in their lithological character and in their fauna, and by some geologists are included in one group, which they term the *Kimeridgian*. The *Astartian* is regarded by Oppel and Waagen as representing the lower part of the Kimeridge Clay; but Renevier places it on the horizon of the upper part of our Corallian. Blake (Q. J. G. S. vol. xxxvii. p. 580) correlates the Astartian of France, which, from its fossils, appears to be the same as that of the Jura, with the Kimeridge Passage-beds, including the Abbotsbury and Westbury ironstone, and with the basal portion of the Lower Kimeridge Clay.

Greppin (*op. cit.* p. 101) gives 210 species from the Astartian of the Bernois district, 40 of which occur in England at the following horizons respectively:—

Lower Oolites.....	2
Coralline Oolite and Coral Rag.....	15
Kimeridge Passage-beds (including the Abbotsbury Ironstone).....	7
Kimeridge Passage-beds and Lower Kimeridge Clay.....	7
Upper Kimeridge.....	1
Corallian and Lower Kimeridge.....	8
	—
	40

The Kimeridge Clay of England has been fully described by Blake (Q. J. G. S. vol. xxxi. p. 196), and the following fossils, amongst others, he regards as being peculiar to the Kimeridge Passage-beds (including the Abbotsbury Ironstone):—

Natica eudora, *D'Orb.*
Pleuromya Voltzii, *Ag.*
 — donacina, *Ag.*
Goniomya parvula, *Ag.*

Arca sublata, *D'Orb.*
Lucina plebeia, *Contj.*
Rhynchonella inconstans, *Sow.*

These 7 species are found in the Astartian of the Jura, together with the following Lower-Kimeridge-Clay forms:—

Strophodus reticulatus, *Ag.*
Natica microscopica, *Contj.*
Pleuromya tellina, *Ag.*
Arca rhomboidalis, *Contj.*

Astarte supracorallina, *D'Orb.*
Terebratula Gesneri, *Et.*
Cidaris spinosa, *Ag.*

From these lists it will be seen that the Lower-Kimeridge-Clay fauna is well represented in the Astartian of the Jura. As stated above, 15 Corallian species also occur in these beds, and some of them range up into the Pterocerian; but these fossils must be regarded rather as the dying-out of the Corallian fauna than as indicating any affinity of the Astartian of the Jura with the Corallian of England. It must be remembered that the Astartian beds are formed principally of limestones, with but little argillaceous admixture, and the absence of the latter material would be favourable to the prolonged existence of some portion of the Corallian fauna of the Jura; whilst in England the Corallian fauna for the most part disappeared at the introduction of the great clayey period at the close of Corallian times. Admitting this to be the case, the Astartian must be regarded as representing part of our Lower Kimeridge Clay and Kimeridge Passage-beds. Blake makes the beds with *Ostrea deltoidea* &c., at the base of the Lower Kimeridge, the upper limit of the Astartian in England; but there appears to be some evidence for including a larger portion of our Lower Kimeridge in the Astartian. *Astarte supracorallina* has been found in the Jura only in the Astartian beds, and this fossil, or at least a form which is very hard to distinguish from it, occurs fairly commonly in the Lower Kimeridge Clay of England, and has also been recorded from the Sandsfoot Clays and Grits (Supracoral-line beds of Blake and Hudleston). In Cambridgeshire the following zones have been made out in the Lower Kimeridge Clay (Sedgwick Essay for 1886, MS.):—

4. Clays crowded with *Exogyra virgula*.
3. Clays with *Ammonites alternans*.
2. „ „ *Astarte supracorallina*.
1. „ „ *Ostrea deltoidea*.

The fossil characteristic of zone no. 2 has not, as yet, been found in this district above that horizon. If the range of *Astarte supracorallina*, which is characteristic of the Astartian, be of any value in indicating the limits of the equivalents of the beds in the two areas, the clays containing this fossil in England should certainly be included in the Astartian. The other Lower-Kimeridge fossils which are present in the Astartian of the Jura also support this view.

The fauna of the Astartian beds in the southern district of the Jura has much in common with that of the northern district, and a comparison of their fossils with that of the Lower Kimeridge of England points to much the same conclusion.

The *Pterocerian* fauna of the northern part of the Jura contains 181 species (Greppin, *op. cit.* p. 110): 31 of these pass down to the Astartian, 14 also occur in the Virgolian, and 17 are common to the Astartian, Pterocerian, and Virgolian, and there are 6 species which have a somewhat wider range; this leaves about 120 species peculiar to the Pterocerian. The 181 species include 34 which have been met with in England in the following beds respectively:—

Lower Oolites	2
Corallian	8
Kimeridge Passage-beds and Lower Kimeridge . .	14
Portland Beds	3
Ranging from Coral Rag to Kimeridge Passage-beds	5
Ranging from Upper Calcareous Grit to Portland Beds	2
	34

The 14 Kimeridge-Clay species include 6 which pass up from the Astartian; the following are the remaining 8 species:—

Ammonites rotundatus, <i>Sow.</i>		*Trigonia muricata, <i>Goldf.</i>
Neritopsis delphinula, <i>D'Orb.</i>		*Astarte pesolina, <i>Contj.</i>
Pholadomya acuticosta, <i>Sow.</i>		Cardium pseudoaxinus, <i>Thurm.</i>
— Protei, <i>Ag.</i>		Ostrea Bruntrutana, <i>Thurm.</i>

The two species marked * are also recorded from the Virgolian. The commonest and most characteristic fossil of this stage (*Pteroceras oceani*) has not, as yet, been found in England. The Abbotsbury Ironstone has yielded a species of *Pteroceras* (Q. J. G. S. vol. xxxiii. p. 274); this deposit is, as already stated, included in Blake's Kimeridge Passage-beds, and is too low in the series to be correlated with the Pterocerian. No true Pterocerian fauna is known to occur in England, though, as Blake points out (Q. J. G. S. vol. xxxi. p. 215), "several of the less peculiar fossils of that group are found associated with Lower Kimeridge forms," a statement which fully agrees with the conclusions to be derived from the fossils quoted above. In the absence of a Pterocerian fauna in England, it is of course difficult to find their equivalents in this country; what evidence there is clearly points to some portion of the Lower Kimeridge of England as being the representative of the Pterocerian of the Jura. Blake, in referring to the Pterocerian of the Paris basin, states that the stage "is adopted solely in deference to its probable justification in the area where it was first introduced, namely the Jura, and to its distinctness palæontologically when the fossils of any locality have been studied. Neither in the basin of Paris, nor in any other part yet studied, is it sufficiently distinct to be of much importance in the field" (Q. J. G. S. vol. xxxvii. p. 578). It has already been shown that in the Jura the Pterocerian fauna is very well marked, and it would appear that it diminishes in importance in a north-westerly direction, and disappears altogether before reaching England.

The Pterocerian fauna of the southern district of the Jura is poorer in species than that of the northern, since it numbers only 63 species (Jaccard, *op. cit.* p. 193), 17 of which occur in England (9 in the Corallian, 4 in the Lower Kimeridge, 1 in Upper Kimeridge, and 3 range from Corallian to Lower Kimeridge). *Exogyra virgula** is recorded from these beds, but apparently does not occur in any abundance. They may, however, represent a portion of the Virgulian of the northern district, which has not been recognized as a distinct formation in the central Jura.

Greppin (*op. cit.* p. 118) records 118 species from the Virgulian of the Jura Bernois, and this includes 21 British species, of which 1 occurs in the Lower Oolites, 6 in the Kimeridge Passage-beds and Lower Kimeridge, 1 in the Upper Kimeridge, 3 in the Portland Beds, while 7 range from the Corallian to the Lower Kimeridge, and 3 from the Corallian and Lower Kimeridge to the Portland beds. The Lower-Kimeridge forms are:—

<i>Ammonites longispinus</i> , <i>Sow.</i>		<i>Astarte pesolina</i> , <i>Contj.</i>
<i>Anatina parvula</i> , <i>Et.</i>		<i>Lima virgulina</i> , <i>Contj.</i>
<i>Arca sublata</i> , <i>D'Orb.</i>		<i>Exogyra virgula</i> , <i>Desm.</i>

Four of these fossils are peculiar to the Virgulian of the Jura. The upper beds of the Lower Kimeridge Clay of Cambridgeshire are crowded with *Exogyra virgula* (Sedgwick Essay for 1886, MS.), in fact one bed is for the most part made up of the shells of this small oyster. Precisely the same thing occurs in these beds in the Jura, the only difference being that in the last-named locality the matrix in which the fossils are imbedded is slightly more calcareous than the zone in England. *Ammonites longispinus* is associated with *Ex. virgula* in the upper portion of the Lower Kimeridge of Cambridgeshire. Elsewhere in England *Ex. virgula* has been commonly met with in the Lower Kimeridge, and extends into the lower part of the Upper Kimeridge; it is, however, more characteristic of the former subdivision. The palæontological evidence therefore points to the upper division of the Lower Kimeridge Clay of England as being the equivalent of the Virgulian of the Jura; the latter should certainly be placed on the horizon of the *virgula*-bed at Ely, and probably also on that of the zone of *Amm. alternans* which underlies this. Blake correlates the Virgulian of France with that portion of the Lower Kimeridge which overlies the zone of *Ostrea deltoidea* &c.; but we have seen reason to believe that a part of this is on the horizon of the Astartian of the Jura.

The *Portlandian* of the Jura, although of considerable thickness, contains but a poor fauna. Jaccard (*op. cit.* p. 187) records 47 species, and Greppin (*op. cit.* p. 123) 35 species from this stage; deducting 8 species common to both lists, this gives a total of 74 species from the two districts. Amongst these there are no less than

* Oppel (*op. cit.* p. 751), apparently referring to the Pterocerian of the Bernois district, mentions the occurrence of a solitary specimen of *Exogyra virgula* from this stage.

16 species which have been met with in the Portlandian of England :—

Ammonites gigas, <i>Ziet.</i>	Cyprina Brongniarti, <i>Pict.</i>
— Gravesianus, <i>d' Orb.</i>	Lucina portlandica, <i>Sow.</i>
— Irius, <i>d' Orb.</i>	Trigonia concentrica, <i>Ag.</i>
Natica Marcousana, <i>D' Orb.</i>	— gibbosa, <i>Ag.</i>
— elegans, <i>De Lor.</i>	Mytilus boloniensis, <i>De Lor.</i>
*Pleuromya tellina, <i>Ag.</i>	Pinna suprajurensis, <i>D' Orb.</i>
Plectomya rugosa, <i>Röm.</i>	Pecten suprajurensis, <i>D' Orb.</i>
Cardium dissimile, <i>Sow.</i>	Perna Bouchardi, <i>Opp.</i>

* Also ranges down to the Corallian.

The three first-named fossils in the list are quoted by Judd from the Portlandian of Speeton (Q. J. G. S. vol. xxiv. p. 238), and the others are found in Blake's list of fossils from the Portland Rocks of England (Q. J. G. S. vol. xxxvi. p. 235). The above list clearly shows that the fauna of the Portlandian of the Jura is closely allied to that of the Portland rocks of England, and this is more especially the case with the Portland beds of Speeton, as stated by Prof. Judd (*op. cit.* p. 238). Neither in Greppin's nor in Jaccard's list of Portlandian fossils is there a single species characteristic of the Upper Kimeridge Clay of England, although it is highly probable that these beds are partly the representatives of the Portlandian. We have seen that the beds which underlie the Portlandian, namely, the Virgulian, are probably represented by the upper portion of the Lower Kimeridge Clay. If such be the case, then the Upper Kimeridge must represent, in time at least, a part of the Portlandian of the Jura. Blake correlates the Portlandian of the Paris Basin with the Upper Kimeridge and Portland beds of England. Waagen and Renevier do the same for the Portlandian of the Jura, a view which, from palæontological and stratigraphical considerations, appears to be correct.

The Purbeckian of the Jura has, as already stated, been fully described by Jaccard and De Loriol (Soc. Phys. et d'Histoire Nat. de Genève, vol. xiii.) and also by Maillard (Mém. Soc. Pal. Suisse, vols. xi. & xii.). From palæontological considerations, Jaccard and De Loriol regard the Purbeckian of the Jura as the equivalent of the Purbeck beds of England, of which it represents the Middle and Lower divisions (*op. cit.* p. 64). Maillard arrives at exactly the same conclusion (*op. cit.* vol. xi. p. 133). He states that 16 of the Purbeckian fossils occur in England in the following beds :—

Three are exclusively Wealden :—

Lioplax inflata, <i>Sandb.</i>	Unio subtruncatus, <i>Sow.</i>
Psammobia tellinoides, <i>Sow.</i>	

Three species are found in the Wealden and Purbeck :—

Corbula alata, <i>Sow.</i>	Cyrena media, <i>Sow.</i>
Cyrena angulata, <i>Sandb.</i>	

Ten species occur in the Purbeck :—

Cypris purbeckensis, Forbes.
Physa Bristowi, Forbes.
 ——— *wealdiensis*, Maillard.
Limnæa physoides, Forbes.
Leptoxis subangulata, Sandb.
Valvata helicoides, Forbes.

Hydrobia Chopardi, Sandb.
Corbula duristonensis, Maillard.
 ——— Forbesii, De Lor.
Protocardia purbeckensis, Maillard.

He further adds that the fauna of the upper brackish beds is found exclusively in the upper part of the Middle Purbecks of England. Maillard (*op. cit.* p. 134) gives the following table of correlations :—

JURA.		ANGLETERRE.
Couches Saumâtres supérieures.	Middle Purbeck.	Niveaux à fossiles Saumâtres.
Couches nymphéennes.		Faunes principalement d'eau douce.
Marnes à gypse.		Dirt Beds.
		Lower Purbeck: Gypse à Durlstone Bay.
Dolomie saccharoïde à <i>Corbula inflexa</i> et <i>Cyrena rugosa</i> .		Portlandien à <i>Cyrena rugosa</i> .

The palæontological evidence is undoubtedly in favour of the correlation above mentioned. If so, then the representatives of our Upper Purbecks must be sought for in the Valangian of the Jura; the latter, however, is a marine deposit, and the former freshwater, so that in the absence of fossil evidence the correlation must be made purely on stratigraphical grounds.

In the sub-Wealden boring it was shown that the lower portion of the Purbeck Beds contained a quantity of gypsum, which appears to be somewhat similar in character to that of the lower part of the Purbeckian of the Jura. If our correlation be correct, it is rather a remarkable coincidence, that the same physical conditions prevailed during a portion of this period at such widely separated localities.

In the subjoined table an attempt is made to summarize the correlations arrived at in this part of the paper. It would appear, in some cases at least, that the changes in the physical conditions which caused the termination of one stage and the commencement of the succeeding one did not take place synchronously in England and in the Jura, and on this account the faunas, as it were, sometimes overlap. Hence the difficulty of exactly defining the equi-

valents of the stages in such widely separated areas, and the lines drawn in the table can, in some cases, only be regarded as approximately correct.

Table of Correlations of the Upper Jurassic Rocks of the Swiss Jura and England.

ENGLAND.			SWISS JURA.	
PURBECK.	Upper.	-----	Valangien.	
	Middle.		Purbeckien.	
	Lower.			
Portland stone.		-----	Portlandien.	
,, sand, &c.				
Upper Kimeridge Clay.				
LOWER KIMERIDGE.	Clays with <i>Exogyra virgula</i> .	-----	Virgulien.	
	„ „ <i>Ammonites alternans</i> .		Ptérocérien.	
	Clays with <i>Astarte supracorallina</i> .			
	„ „ <i>Ostrea deltoidea</i> .		Astartien.	
	Kimeridge Passage-beds.			
CORALLIAN.	Supracoralline.	-----	Calcaire à Nérinées.	
	Coral Rag.		Oolithe Corallienne.	
	Coralline Oolite.		Terrain à chailles siliceux.	
	Middle Calcareous Grit.			
	Hambleton Oolite.		Pholadomien.	
	Lower Calcareous Grit.		Spongien.	
OXFORD CLAY.	Clays with <i>cordati</i> Ammonites.	-----	Le fer sous-Oxfordien.	
	„ „ <i>ornati</i> Ammonites.		Zone of <i>Amm. macrocephalus</i> .	
	Kelloway Rock.			
	Cornbrash.		Bathonien.	

[NOTE, April 23.—The fossils from the Lower Greensand of Upware, which have been referred to the genus *Nerinea*, include two species figured by Mr. W. Keeping (Sedgwick Essay for 1879, pl. iii. figs. 7 & 8) and some undoubtedly derived forms (*op. cit.* p. 45). Since the question of the occurrence of *Nerinea* in the Lower Greensand of Britain was raised, the two above-mentioned figured specimens have been sliced. The interior of these shells is filled with the deposit in which they were found; and this, together with their mode of preservation, clearly proves them to be of Lower Greensand age.

The external form of the two figured species is not unlike that of some *Nerineæ*; but on examining the inside of the whorls and the columella, the spiral thickenings or folds, so characteristic of the genus *Nerinea*, are not seen, nor is there any thing to indicate them in either specimen except the "two broad faint grooves seen in places upon the inside cast," mentioned by Mr. Keeping (*op. cit.* p. 94) as occurring in *N. tumida*. These faint grooves are undoubtedly due to a slight variation in the thickness of the shell, but are totally different from the spiral thickenings of *Nerinea*.

The specimens have been submitted to Mr. Hudleston, and he is of opinion that *Nerinea*, sp. (*op. cit.* fig. 7), is an undoubted *Cerithium*; and that *N. tumida*, Keeping, belongs to the Cerithiadae rather than to the Nerinaeidae.

The other specimens, being derivatives, may have come from the underlying Corallian.]

DISCUSSION.

Mr. ETHERIDGE said it was difficult to criticize this paper until it appeared in print. It dealt with a mass of detail, and Mr. Roberts had had peculiarly favourable opportunities for working out the question both in Switzerland and in Cambridge. The work must be compared with that done by Mr. Hudleston and Mr. Blake. The speaker thought that the Pterocerian was represented at Portland; but the Portland and Kimeridge beds of England were peculiar, and could not be exactly correlated abroad.

Mr. HUDLESTON agreed with Mr. Etheridge as to the advantages under which Mr. Roberts had studied the Jurassic rocks. Mr. Roberts had lately undertaken a very difficult task, the examination of the Jurassic beds near Cambridge, and had now entered on an even more difficult inquiry. It was not very easy to find a classification that would fit all countries. The Oxfordian and Callovian were comparatively simple, on account of their fossils being widely distributed, and, to some extent, the Corallian was not difficult to trace, though there was a difficulty about the zone of *Cidaris florigemma*. The higher Oolites were more difficult to correlate. Thus *Nerinea* is wanting above the Corallian in England (except a reported occurrence in the Neocomian), but it is said to abound in Kimeridgian and Portlandian on the continent. Undoubtedly our Kimeridgian is abnormal. The 700 feet of Upper Kimeridge in Kimeridge Bay would be classed as Portlandian on the continent, and Blake proposed to distinguish even lower beds as Bolonian. The Ammonites afforded some clue to the relations of the beds. The application of the term Portlandian to beds representing true Kimeridge was objectionable. He was surprised to hear Mr. Etheridge say that representatives of Pterocerian beds occurred at Portland. So far as Mr. Blake and he had been able to ascertain, no such representatives could be detected.

Prof. HUGHES said that the so-called Neocomian of Upware rested on Coral Rag, and the fossils might have been derived. He called

attention to the important differences between the limits of the stages in England and those bearing the same name in Switzerland.

Mr. ROBERTS, in reply, said that *Cidaris florigemma* was found abundantly in the 'Terrain à Chailles siliceux.' *Nerinea* he had found in Astartian and Pteroceran. The Portlandian of the Jura appeared to be a single group.

Mr. ETHERIDGE said there were specimens, apparently, of *Pteroceras oceani* from Portland in the British Museum.

22. *On the LEAF-BEDS and GRAVELS of ARDTUN, CARSAIG, &c., in MULL.* By J. STARKIE GARDNER, Esq., F.G.S. *With NOTES* by GRENVILLE A. J. COLE, Esq., F.G.S. (Read January 12, 1887.)

[PLATES XIII.-XVI.]

THE Ardtun leaf-beds have once before formed the subject of a communication to this Society*. Its author was the Duke of Argyll, and its interest exceptional, as it once for all fixed the age of the great Trap formation of the Inner Hebrides; and geologists learned that, even since a period so recent as the Tertiary, beds of most stubborn rock, exceeding 1000 feet in thickness, had been denuded and abraded until, over extensive areas, little more than the merest vestiges of them remained. The value of this discovery to the geologist can hardly be overestimated, for the data then furnished materially assisted to determine the age of the Traps stretching from Antrim to Greenland.

The fossil plants, to which so much importance attached, were briefly described in this paper by Edward Forbes, and all the most characteristic forms were figured. He inclined to the idea that they might be of Miocene age, but did not commit himself definitely; while the Duke of Argyll, even though author of the paper, refrained from expressing any opinion. Prof. Heer, however, who was then describing the Miocene flora of Ceningen, pronounced them to be Miocene; and the weight of his authority has been such, that no serious attempt has ever been made to reexamine the evidence on which his opinion was based. This ruling was extended to the fossil plant-beds of Greenland, with the result that a vast series of physical changes, which extended over the entire Tertiary period, have been crowded into a single stage, the Miocene. It is 35 years since the Ardtun flora was described, when the study of fossil plants was so far in its infancy that the occurrence of Dicotyledons in Cretaceous beds was unsuspected, and even plants of Eocene age were very imperfectly known. In the concluding part of this paper evidence will be brought forward to show that it should actually be placed very low down in the Eocene.

The Ardtun beds are situated in Mull, long. $6^{\circ} 13' - 14' W.$, and lat. $56^{\circ} 20' - 21' N.$, in the promontory of Ardtun, between Loch na Làthaich and Loch Scridain. The earlier observations are recorded by the Duke of Argyll, and, since 1851, the beds and their fossils have been continually referred to, particularly in text-books on geology and guides to the Western Isles; but the spot itself seems to have been little visited, and nothing has been added to the Duke's descriptions. Much additional light has, however, been thrown on the Trap-formation generally by the works of Professors Geikie and Judd, and Dr. James Geikie †.

* Quart. Journ. Geol. Soc. vol. vii. p. 89.

† Prof. Geikie, Quart. Journ. Geol. Soc. vol. xxvii. p. 279, 'Nature,' Nov. 4, 1880, and elsewhere; Prof. Judd, "On the Ancient Volcanoes of the Highlands, and the Relation of their Products to the Mesozoic Strata," Quart. Journ. Geol. Soc. vol. xxx. p. 220, and "On the Strata of the Western Coast and Islands of Scotland," Quart. Journ. Geol. Soc. vol. xxxiv. p. 660. Dr. James Geikie,

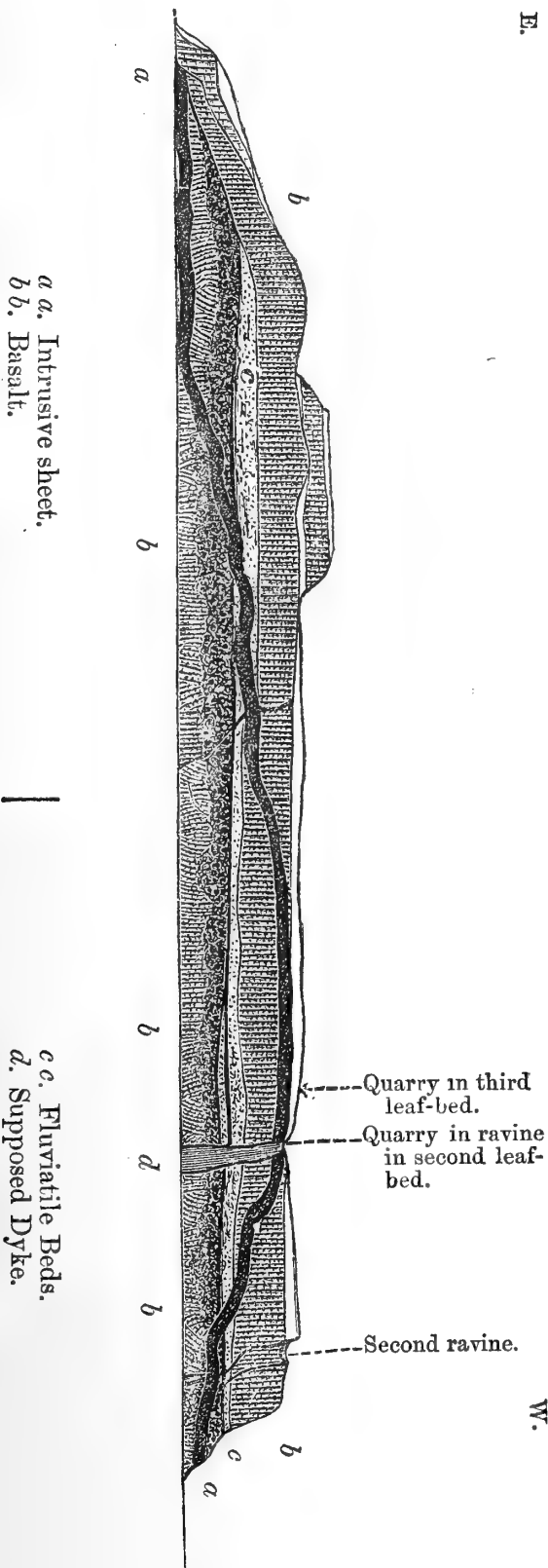

Fig. 1.—*Diagrammatic Elevation of Ardtun Head.*
(Length about $1\frac{1}{2}$ mile.)

“On the Geology of the Færøe Islands,” *Trans. Royal Soc. Edinb.* vol. xxx., has also dealt with a more northerly extension of the same formation. Other equally important works, bearing more or less directly upon the subject, are those on the Antrim Basalts, by Mr. W. H. Baily, in the *British Association Reports*, and our *Quarterly Journal*; on the Traps, and their fossils, of Iceland and Greenland, by Heer, Nathorst, and Saporta; and on the beds with similar floras in North America, described by Dawson, Lesquereux, and Newberry.

We propose to describe the more important outcrop first, then those on the coasts of Carsaig and Burgh.

The sedimentary rocks at Ardtun, of which the leaf-beds form a part, appear between basalts along the seaward face of the headland for a distance of somewhat over a mile, and their preservation is obviously due to the circumstance that they have been entirely sealed up by great overflows of trap (see fig. 1). They dip under the sea on the west or Loch-na-Làthaich side, as well as to the eastward, but it is probable that the width of the headland corresponds approximately with their original limits; for though the proper horizon reappears again in the next headland, half a mile distant, no trace whatever of them is visible there. Patches of pisolitic iron and bole are seen here and there among the basalts along the shore up Loch Scridain, but on higher horizons. They rest upon a mass of basalt about 80 feet thick, the upper half of which is amorphous and vesicular, while the base exhibits the most beautifully formed and, for the most part, slender columns. These are, in places, curved in every direction, even lying almost parallel to the bedding*, and closely resemble those of the "clam-shell" cave at Staffa, about seven miles distant. This columnar trap is riddled with caves, which, though far from rivalling Fingal's Cave, are still of great beauty and interest, the resemblance between their masses being so complete as to render it probable, as already inferred by the Duke of Argyll, that they actually formed part of a single flow. Above the leaf-beds and gravels is a second mass of trap, some 50 feet thick, and rudely columnar in structure, forming a vertical cliff. This flow has apparently been completely denuded off Staffa, but is represented at Burgh Head as described further on. Above this, again, on the crest of the headland, are fragments of a third flow of a similar kind, neither of them being scoriaceous or amygdaloidal, or showing any tendency to decompose. This so far simple stratification of the head is complicated by the intrusion of a sheet of very dense trap (fig. 1, *a*), which penetrates it at the sea-level on its east side, and after forming extensive but deeply indented horizontal plateaux a little above the sea-level, forces a devious course upward through the columnar and other basalts and the sedimentary beds, and becomes, owing to the extensive denudation it has been subjected to, exposed at the surface near the front of the head. It dips again, however, almost immediately, passing in a sinuous course downward into the lower basalt, and, after forming a few small promontories, finally disappears under the sea at the western side of the head. It is just possible, but not probable, that the ravine in which the leaf-beds are exposed may be the site of a feeder of this subterranean flow. The intrusive sheet is of perfectly uniform thickness, and shows a starch-like weathering on its exposed face. The lines separating it from the basalts into which it is intruded are perfectly sharp, and its clean and resistless, but devious, passage alike through every quality of rock resem-

* Macculloch, 'Western Isles of Scotland,' vol. i. p. 496, mentions the occurrence of columns parallel to the bedding, and the rule that columnar structure is developed at right angles to it does not apply in these cases.

bles nothing so much as that of an electric discharge through the air. It looks as if it had been injected with immense force while molten, without reaching the surface; and the sudden intrusion of such a sheet may well have been accompanied by a violent earthquake. Examples of these intrusive sheets are by no means uncommon in the traps, and have been observed more particularly by Macculloch and Geikie. They are readily distinguished by their compact texture and starch-like weathering amidst the piled up subaerial flows. From the summit of the head the remains of apparently the same sheets of perfectly horizontal traps can be seen stretching over hundreds of square miles. It is well known that these are believed to be part of a Trap-formation that was once continuous from Antrim, through the Inner Hebrides, to the Faröes, Iceland, and even Greenland*. The included plants show that the flows were approximately synchronous, speaking geologically, over the area, and they are eminently representative of the type of massive eruption so graphically described by Prof. Geikie†, who says:—"This association of thin nearly level sheets of basalt, piled over each other to a depth of sometimes 3000 feet, with lava-filled fissures sometimes 200 miles distant from them, presented difficulties which, in the light of modern volcanic action, remained insoluble. The wonderfully persistent course and horizontality of the basalts, with the absence or paucity of interstratified tuffs, and the want of any satisfactory evidence of the thickening and uprise of the basalts towards what might be supposed to be the vents of eruption, were problems which I again and again attempted to solve. Nor, so long as the incubus of 'cones and craters' lies upon one's mind, does the question admit of an answer." The action of the Traps on the older sedimentary strata, shown by Macculloch in his sections of the coast of Trotternish, in Skye, appears inconsistent with the view that they were poured out as lavas from elevated cones. He illustrates a dyke which he speaks of as a mile wide, giving off intrusive veins ('Western Isles,' vol. iii. pl. 17), and which must have welled through long parallel fissures in immense gushes, which appear to have flowed from seaward towards the existing shore-lines, which in some cases still coincide with their boundaries.

Prestwich‡ advocates that the term Trap should be retained for flows from fissure-eruptions, and Lava for those which have escaped from craters. Whether, however, the present limits of the formation in this direction, even approximately, coincide with the original ones is a question not easy to answer, in face of the colossal denudation to which they have been subjected. The traps at Burgh and Carsaig are over 1000 feet in thickness, and are so horizontal that they could scarcely have thinned so considerably within so short a distance as Ardtun, where now no more than 150 feet remains. The gneiss of Loch na Lathaich may, however, be part of an old ridge against which they abutted. Their limits towards Benmore are far

* Geikie, Quart. Journ. Geol. Soc. vol. xxvii. p. 279.

† 'Nature,' November 4, 1880.

‡ Prestwich, 'Geology,' vol. i. p. 389.

less defined, and all attempts have failed to trace their connexion with the older, and perhaps also newer, flows of lava that proceeded from that region. They show no decided dip either towards or away from it; and it is difficult to say where the terraced structure of the plateau Traps definitely ends. That even then there was an elevated tract not far off, possibly the Benmore region, which had been the scene of acid eruptions, is indicated by the composition of the Ardtun gravels, as described by Mr. Cole. But the crest of Benmore itself appears to me to be a fragment of the wall of a crater which may have occupied the site of Loch Beg, from which later lavas have flowed*. It is an open question whether the traps ever actually extended over the central part, or far beyond their present limits in Mull, or over other districts where there are now no traces of them. Contemporary dykes have, it is true, been traced by Geikie, Jack, and others right across Scotland and even England, but these were probably subordinate to the main fissures of eruption, which must have been parallel to the long axis of the formation, and their lavas need not necessarily have reached the surface.

To return to Ardtun. We have already seen the horizontal extent of the sedimentary series, and pointed out its position relatively to the Traps which have enclosed it. It consists, where thickest, towards the centre of the headland, of shaly clays and limestones, and coarse indurated gravels and sands, which thin rapidly to the west and pass beneath the sea, in not greatly diminished thickness, to the east. The section given (fig. 1) shows them to be thickest near a ravine, and again some distance eastward; but in the latter locality the laminated leaf-beds beneath the gravel, if present, are entirely concealed by talus. The fossils have been obtained from the sides of the ravine, rendered famous by the paper on them already referred to †, and more recently from a spot a little to the east.

On the west side of this ravine (fig. 2) we see, first, a bed of buff or cream-coloured, soft, laminated sandstone (*h*)‡, the edges of which are suddenly turned up and plastered in one place against the overlying beds, suggesting that the ravine must be due to the upward passage of a dyke which has since decomposed and weathered away—a view supported by the gravel walls on both sides of the ravine, which have the appearance of having been subjected to a more intense heat than elsewhere. There are also some included fragments of a pale drab-coloured stone on the opposite side (fig. 3). On the east side of the ravine I undertook, by aid of a Government grant from the Royal Society, some rather extensive quarrying operations, and the following beds were seen:—At the base, on the amorphous Trap (*i*), is carbonaceous rubble filling in its rugged surface, which may be set down at 1 foot. Above this is 2 feet of bedded river-sand (*g*), now indurated,

* The structure of the peak resembles that of the peaks forming the walls of the Grand Cûrral in Madeira, though denuded to an infinitely greater extent.

† Argyll, Quart. Journ. Geol. Soc. vol. vii. p. 89.

‡ This occupies the position of the third leaf-bed of the Duke.

Fig. 2.—Section of west side of Ravine, Ardtun Head.
(Relative thickness of leaf-beds exaggerated.)

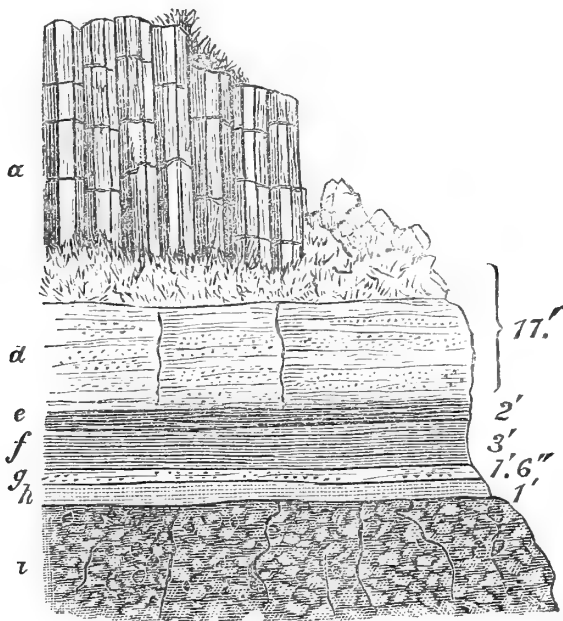

- a. Rudely columnar basalt, with grass at foot.
- d. Gravel.
- e. Hard bed, with *Onoclea*.

- f. Black leaf-bed.
- g. Gravel.
- h. Light leaf-bed.
- i. Amorphous basalt.

There are many stems in this part of the Black leaf-bed, one of which was 3 feet long and 5 inches across. The light leaf-bed is unfossiliferous here.

Fig. 3.—Quarry in east side of Ravine, Ardtun Head.

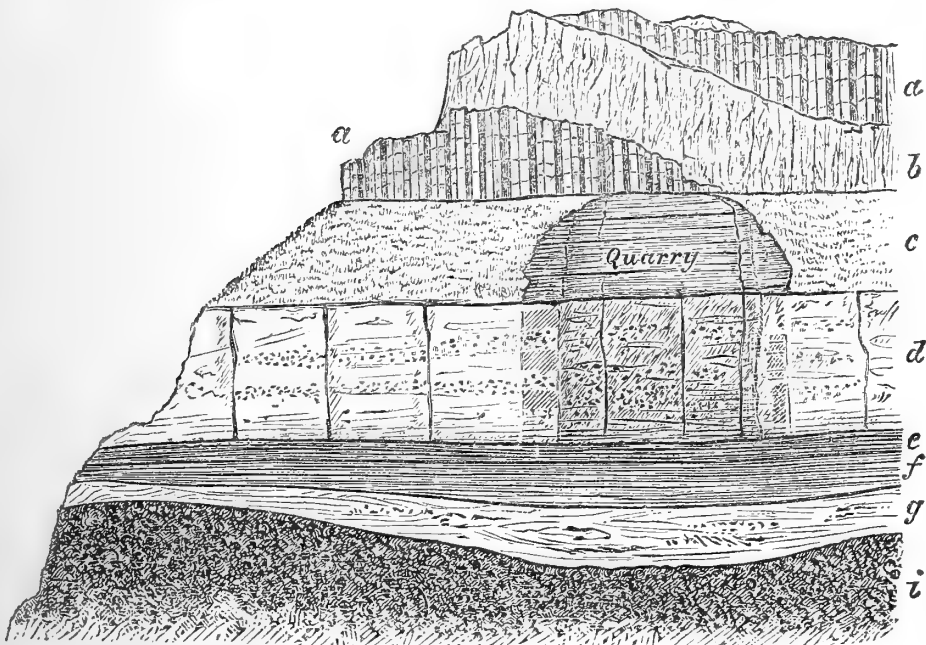

- a. Rudely columnar basalt.
- b. Intrusive sheet.
- c. Sandstone, more or less fissile, 8 ft.
- d. Indurated Gravel, 7 ft.

- e. Hard bed, with *Onoclea*, 1 ft.
- f. Black leaf bed, 2 ft. 4 in.
- g. Indurated gravelly sand, 2 ft.
- i. Amorphous basalt, with rubble.

and then a bed of black crumbly shale (*f*), 2 feet 4 inches thick, crowded with leaves*. The lowest part of this is greatly squeezed, and destitute of recognizable fossil leaves †, but a few succeeding layers contain innumerable specimens of a simple ovate leaf, the *Rhamnites* of Edward Forbes ‡, then some squeezed layers with decomposed leaves and *Equisetum*, and, lastly, a layer made up almost entirely of the large leaves of *Platanites*, Forbes. Above this, but separated by a perfectly sharp plane, is a bed (*e*), one foot thick, of very dark, intensely indurated whinstone or rag, originally fetid mud, in which immense leaves of *Platanites* are rolled and folded together with broken and mostly very macerated fronds of *Onoclea* (*Filicites*) *hybridica*, Forbes, broken stems of *Equisetum*, and occasional twigs of *Taxus* (*Taxites*) *Campbellii*, Forbes. Magnificent specimens from this layer were obtained and are now in the British Museum, one, not far short of a square yard in surface, exhibiting specimens of all these except the last. Another plane separates it from a similar bed, but with few fossils, which passes gradually upward into the overlying gravel (*d*), at this point only 7 feet thick; this in turn passes into some fissile sand (*c*), becoming softer at the top and, in all, 8 feet thick. The Duke's first leaf-bed is at this horizon, though I failed to find it fossiliferous. The parting between this and the trap above is carbonaceous rubble, similar to that at the base.

The gravel-bed is of the greatest interest, and its composition has been most kindly investigated by Mr. Grenville Cole, who himself collected the different specimens he describes.

Note on the Gravel of Ardtun. By GRENVILLE A. J. COLE, Esq.,
F.G.S.

The main constituents of the gravel-beds are flints and lava-fragments, the proportions in which they occur varying considerably in different layers. The larger masses are well rolled, the smaller more so than would appear on fractured surfaces; and the features of the beds are quite distinct from those of a tuff or a volcanic breccia. The flints, despite their characteristically white and altered condition, retain abundant traces of organisms and of the chalk from which they have been derived. It may be fairly questioned, indeed, whether these hard white fragments are not in many instances comparable to the silicified chalk of the area rather than to the flints developed by concretion in that chalk; and whether they were not

* The second leaf-bed of the Duke of Argyll, the third being unrepresented on this side of the ravine. All these layers proved, however, to be so crumbling as scarcely to repay working, and large quantities are left exposed *in situ*.

† A very similar shale, with some of the same plants, was discovered in the Isle of Canna by Prof. J. A. Harvie-Brown, who informs me that it occurs in a cave on the north side of Canna, close to the shore. He says:—"Those we obtained were at the exposed side of the shale-seam which projected from the rock close to the floor of the cave. I think a fisherman, Mr. Isaac, if still at Canna, could point out the place."

‡ Quart. Journ. Geol. Soc. vol. vii. p. 103, pl. i *Berchemia* of Heer.

of a more calcareous nature when first included in the gravels *. In section they afford a rich harvest of organic remains, including, in one of the instances examined, glauconitic casts sufficiently numerous to give a distinct greenish tinge to the cut surface of the specimen.

Pebbles of grey quartzite are also found, and the matrix of the gravel is composed of quartz- and felspar-sand, comminuted particles of lava, and occasional glauconitic grains. Though the crystalline granules may have been largely derived from the old gneissic floor of the district, yet in some cases they retain intrusions of glassy matter which indicate their original occurrence as porphyritic crystals in dykes or lava-flows.

The pebbles of volcanic material might be expected to exhibit many interesting characters, such as are usually lost to us by weathering before a lava-stream becomes entombed among later accumulations †. We find, in fact, rolled fragments of scoriaceous basalt-surfaces; and the microscope reveals many other products of rapid cooling, such as colourless pumice and particles of basic glass, the latter showing fluidal structure and crystallites in various stages of development.

A large number of the pebbles, whether grey-green, brown, or even pink, are derived from pre-existing basaltic flows, which have yielded specimens of their more compact, though not of their doleritic, portions. In one brown-pink example we have, with a fresh monoclinic pyroxene, olivine so ready in its decomposition, and giving rise to such rich brown products, as to suggest a highly ferruginous variety. In another and greyer specimen the matrix is largely glassy, the more crystallized portions being gathered into little flecks and patches visible to the naked eye.

But the main interest rests with the examples, preserved thus locally, of rocks which have been lost to us throughout this district under the enormous outpourings of basalt.

At the first glance many of the Ardtun pebbles recalled, in a redder and altered form, the sanidine-lavas of Ischia or the Rhine. Their microscopic examination fully bears out this view, which has been confirmed by further evidence. One specimen, seen in section, has the familiar pale augites, the abundant porphyritic felspars, the fluidal glassy matrix that one associates with trachytic flows. The specific gravity proves to be only 2.45, and the felspar, as determined carefully by Szabó's method, contains more potash and less soda than many accredited sanidines.

Another more crystalline specimen consists of crowded felspars

* Cf. Judd, *Quart. Journ. Geol. Soc.* vol. xxx. p. 228.

† Prof. Jukes, in 1860, writes of a similar but far more ancient deposit:—
 "It had very much the aspect of one of the beds of volcanic breccia and conglomerate one so often sees about recent and active volcanoes; and it occurred to me that in these pebbles of vesicular trap we might have preserved the only fragments of the more superficial parts of the flows of molten matter."
 ("Igneous Rocks of Arklow Head," *Journ. Geol. Soc. of Dublin*, vol. viii. p. 32.)

and a few small flakes of biotite. Its specific gravity is 2.50. The felspar gives, by Szabó's method, the reactions of a soda-orthoclase, and the rock may be classed as fairly with the sanidophyres (or sanidine-felsites) as the preceding specimen with the trachytes. The occurrence of a lava of this composition makes one hopeful as to the future discovery of nepheline-bearing rocks in Mull.

We may conclude, then, that during the deposition of the Ardtun gravels, when only the first of the basaltic outpourings had taken place, a number of earlier flows must have been still available as sources of material. The chalk-downs which probably then existed, as evidenced by the flints that form so large a portion of certain beds, were themselves overlain by the products of the central cones, the fragments worn from both the aqueous and the igneous series becoming intermingled in the hill-side streams.

G. C.

Externally in the ravine this gravel weathers to almost the colour of the Trap, and the bedding of the shingle is not apparent; but the clean freshly blasted surfaces showed the flints altered to a pure white against the steely grey colour of the matrix, which is here so hardened that even the very small pebbles break across when it is fractured.

These gravels are easily traceable for the next 120 or 130 yards across the bluff to the west of the ravine, and the leaf-bed can be followed for about half the distance, though greatly concealed by grass. Here there is another ravine (fig. 4), where the entire thickness was reduced to 14 feet, the sands being distinctly bedded and laminated, and none of the pebbles in the gravel much larger than a filbert. Another good exposure occurs a little further west,

Fig. 4.—*Exposure in Second Ravine, Ardtun Head.*

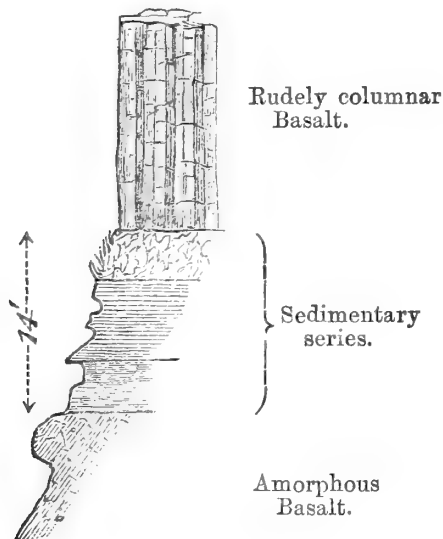

where the thickness appears to be reduced to 12 feet, and then the sedimentary rocks are almost wholly concealed by talus and grass,

though their horizon can always be recognized. As they dip towards the sea the gravels again become coarser and are exposed, as pointed out to me by the Duke of Argyll, for short distances under the cliff of rudely columnar basalt; but no leaves have been found here, and the series is obviously thinning out.

About 100 feet to the east of the principal ravine the leaf-beds are again well exposed in a path hollowed out by sheep (fig. 5), the sedi-

Fig. 5.—Section in face of cliff, Ardtun Head, 100 feet east of the Ravine.



a. Basalt.

b. Gravel.

c. Leaves.

d. Gravel.

mentary beds continuing to increase in thickness for another 150 feet, when we reach a spot where the Duke's third leaf-bed is beautifully exposed, and where one of his sections was taken (fig. 6). The lowest bed is best worked on the neck of a small jutting headland. Under about 30 feet of gravel (c) we have the black crumbling leaf-bed (d) exactly as in the ravine*, but not the whinstone; then 7 feet of bedded sand (e), extremely indurated, with very small angular pieces of flint; followed by 2 feet of partially indurated steel-grey clay (f), which readily breaks up into rectangular parallelograms, stained almost like tortoise-shell at the partings. Faint impressions of large leaves are visible throughout this. Next we have 6 inches of hard, somewhat laminated, carbonaceous sandstone (g), or rag, with impressions of leaves, the most perfect being *Ginkgo*; passing into 3 inches of the finest-grained, bluish limestone, as fine as that of Solenhofen, and with rare, but extremely beautiful leaf-impressions. These are most difficult to find, and when found, to develop, owing to the conchoidal fracture of the matrix. Only small leaves occur in it, by far the most abundant being *Grewia crenulata*, Heer, and *Alnites? Macquarrii*, Forbes. This is followed by another foot of peculiar

* It was quarried for the Duke at this spot, but owing to its crumbling nature, with no great success.

steel-grey clay (*h*), at the base of which the most interesting leaf-bed of all is met with. This consists for an inch or two of layer upon layer of leaves in the most perfect preservation, and retaining almost the colour of the dead leaves themselves. One of the most striking, as well as most abundant, is *Ginkgo*, of large size and purple colour. Still more conspicuous is the large *Platanites hebridicus*, Forbes, one leaf exposed measuring full $15\frac{1}{2}$ inches in length

Fig. 6.—*Leaf-bed and Gravels at Ardtun.* (Scale about 30 feet to 1 inch.)

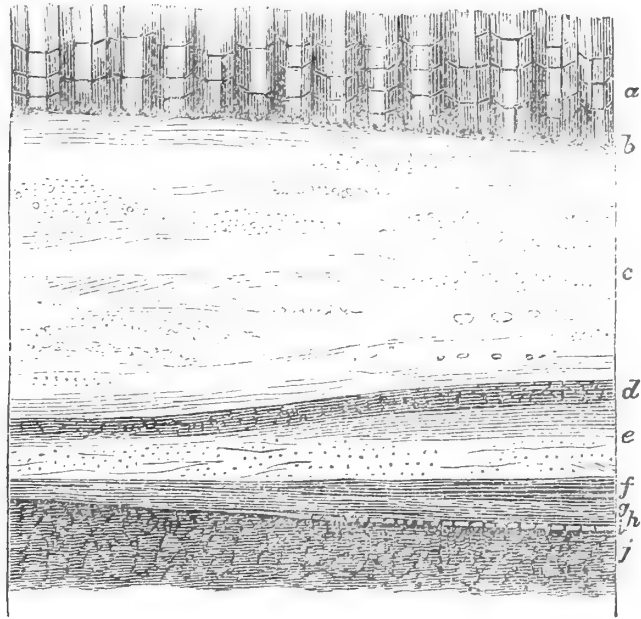

- a. Columnar basalt, 40 feet.
- b. Position of first leaf-bed, obscured by grass, about 2 feet.
- c. Gravel, varying from about 25 feet to a maximum of nearly 40 feet.
- d. Black or second leaf-bed, $2\frac{1}{2}$ feet.
- e. Gravel, about 7 feet.
- f. Grey Clay, 2 feet.
- g. 6 inches laminated sandstone, with 3 inches of fine limestone with leaves at base.
- h. Clay, with leaves at base, 1 foot.
- i. Clunch, with rootlets, 7 inches.
- j. Amorphous basalt, becoming columnar at base, about 60 feet.

and $10\frac{1}{2}$ in breadth. Many other kinds of leaf appeared to be almost equally fine, and the characteristic dicotyledonous trees of this locality possessed at that period relatively large foliage. In the same bed were coniferous branches like the living *Taxodium* (*Glyptostrobus*) *heterophyllum* and *Cephalotaxus*. Unfortunately, every effort to remove and preserve these specimens has failed. There are rush-like stems, from 1 to 3 inches in diameter towards the base, but the beds are almost destitute of monocotyledons, and no trace of Ferns or even of *Equiseta* has been seen in them. This lowest leaf-bed passes into a thin seam of coal in one direction, and rests upon 6 to 9 inches of whitish, clunchy, and concretinary clay (*i*), with rootlets, and with softer clay filling in the rough surface of the underlying basalt (*j*).

About 200 yards to the east the sedimentary beds are traversed by the descending intrusive basalt, and are reduced to 13 feet in thickness with no coarse gravel; and 200 feet beyond this they barely measure 4 feet 6 inches of fissile sandstone, with compact shale at the base, containing well-preserved examples of *Equisetum Campbellii*, Forbes. A quarter of a mile further east the gravels again thicken to over 20 feet, but the beds corresponding to the leaf-beds are not visible, and could not be rendered so without considerable labour. Their horizon soon after passes under the sea-level, and on its re-appearance in the next headland, Rudha Dubh, the rudely columnar basalt rests on the eroded and partly decomposed surface of the amorphous basalt, without the slightest trace of gravels or other aqueous deposit. Search still further up the loch has been equally vain.

Inland, however, in a direction almost due south and south-east, the position of two seams of lignite is indicated on the sketch-map and section accompanying the Duke of Argyll's paper, and he has quite recently caused an excavation to be made near Bunessan, which gave a considerable thickness, without reaching bottom, of black shale and apparently decomposed basalt*.

Following up the Traps still further in the same direction across the Ross, we meet with a similar series of beds on the Carsaig coast, though with some important modifications. The sedimentary series is first visible at the Carsaig Arches, where it consists of from 10 to 12 feet of indurated river-sand †. An upthrust has displaced and raised it almost to the crown of the western arch, but in the long arch it occupies its true position, with its base slightly below the sea-level. It rises eastward, and at the same time increases rapidly in thickness, and where next visible gives the following section (fig. 7).

In this section we have apparently the same flow of rudely columnar basalt (*d*), maintaining a thickness of about 25 feet; then 7 or 8 feet of indurated sandy mud (*e*), passing into a sand; and then a grit (*f*) composed entirely of angular pieces of broken-down flints, with occasional boulders of rock and large flints at the base. This weathers down to a slope of 25° , and rests on a compact mass 9 feet 6 inches thick (*g*), of almost unrolled flints of all sizes up to that of a quartern loaf, in a matrix apparently of broken-down Trap and occasional boulders of the same. Under the flints there is 2 feet of impure bedded sand with indistinct vegetable markings (*h*). An exposure a little nearer the Arches only differs in being of a slightly finer material, with a thin band of lignite at the base.

* [This was taken for a fire-clay when the diggings were commenced. After digesting with acid a precipitate of alumina and ferric oxide remained, amounting to 30.76 per cent. Some aluminous silicates probably remained undecomposed. Under the microscope it was seen to consist of various mineral particles, some being clear and colourless felspar. The flaky green mineral present in quantity, is an alteration-product, fibres of it penetrating other minerals.—G. C.]

† Earl Compton (Trans. Geol. Soc. vol. v. part 2, p. 373) mentions that the arch is 60 feet high, 150 feet long, and from 50 to 60 feet wide, and of basalt, standing on green sand. There are illustrations on the accompanying plates 20 and 21. Prof. Judd had, of course, recognized the fluvial origin of the Carsaig gravels (Quart. Journ. Geol. Soc. vol. xxx. p. 229).

At some distance east the bed of flints greatly increases, and forms a vertical mass from 20 to 22 feet thick, composed exclusively of partly rolled subangular flints of all sizes up to a diameter of about 6 inches, but mostly not larger than potatoes. They are smallest towards the top, and are capped by 2 or 3 feet of flint grit, or sand.

Fig. 7.—Section of lower part of Cliff at Malcolm's Point, near Carsaig. (Scale about 50 feet to 1 inch.)

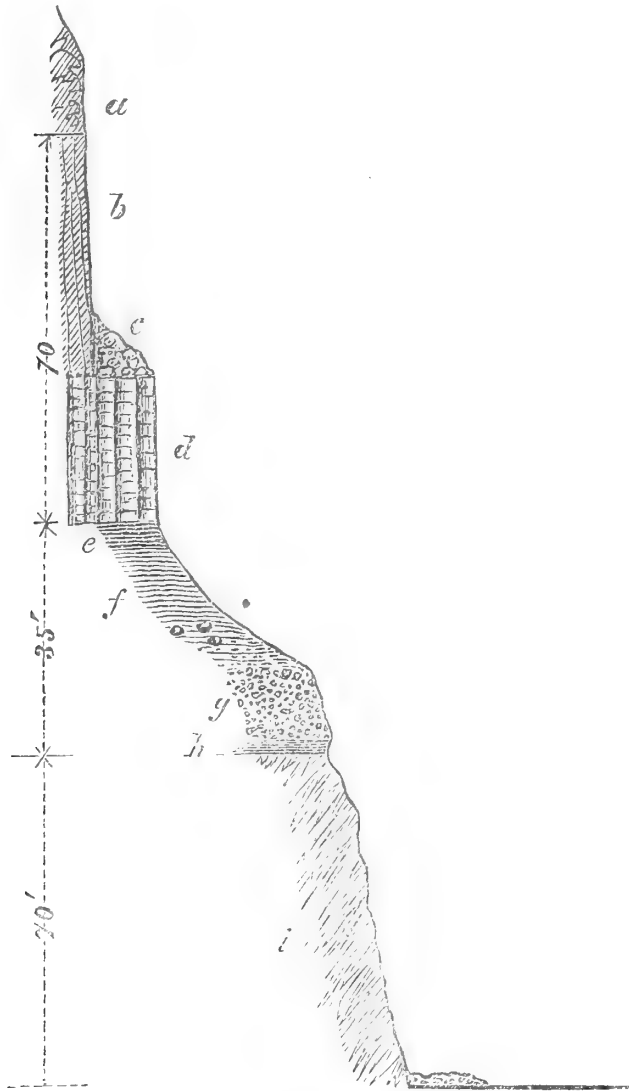

- | | |
|---|---|
| <p><i>a.</i> Amygdaloidal Trap.
 <i>b.</i> Dense Trap, slightly columnar.
 <i>c.</i> Glacial Bed.
 <i>d.</i> Rudely columnar Trap, 25 ft. thick.
 <i>e.</i> Indurated Mud.
 <i>f.</i> Grit.</p> | <p><i>g.</i> Flint Conglomerate.
 <i>h.</i> Sand, with lignite.
 <i>i.</i> Amorphous Trap, partly obscured by grass, &c.; the last half invisible and perhaps a different flow.</p> |
|---|---|

while underneath is a conglomerate, 12 to 14 feet thick, of basalt with a few large and perfect flints and many angular flint-flakes. The base of this series is 60 feet above high water at this point, and no traces whatever of it are seen in the cliffs further east. Nearly 100

feet above them, however, is a disturbed bed of black shale, resembling that of Ardtun, from 1 to 2 feet thick, resting on thin laminated sand formed of angular quartz grains, which can be traced for a considerable distance, without, however, containing any plant-impressions. The beds rise very rapidly, and this shale is soon 310 feet above the beach, whilst about a quarter of a mile further on the top of the sandstone regarded as Cretaceous suddenly appears*, 220 feet above high water, thus occupying the horizon at which we might have looked for a continuance of the flint gravels †.

The headland of Burgh rivals the Innimore of Carsaig in grandeur of scenery, its cliffs even surpassing the latter in height, and forming an almost vertical escarpment of Traps, which for some distance exceeds a thousand feet in depth. It presents the usual alternations of columnar and amorphous, amygdaloidal and rudely columnar flows, with intrusive sheets of dense Traps with starch-like jointing.

At the base there appears to be an extensive ash-bed, and directly over this columnar basalt, on the same horizon and probably the same flow as that of Ardtun and Staffa; above this is a bed of dark, loamy, unfossiliferous sand, marking apparently the horizon of the leaf-beds ‡. This is 3 or 4 feet thick, and includes clays, in places, with vegetable matter. Above the leaf-bed horizon is rudely columnar basalt as at Ardtun and Carsaig; then amorphous trap with a few included flints and other stones; and then a massive flow of Trap, over 70 feet in depth. Above this, again, are several hundred feet of Traps, without any ash-beds, which latter do not

* [Composed of quartz grains, for the most part very angular.—G. C.]

† In the absence of proper horizontal measurements, which I did not at the time realize were so important, it is impossible to ascertain the true dip; but assuming the extreme points mentioned to be half a mile apart, roughly plotted, it appears not much less than 5° or 6° . The beds, whether viewed from the sea or the shore, do not indicate to the eye such a dip, and the horizontal terracing of the cliff on the landward side equally negatives it. If the dip does exist, the base of the flint gravels would be nearly 150 feet above the top of the Cretaceous Sandstone. A much more accurate description of the Carsaig section is needed, for it abounds in interest. Among the more striking objects in the volcanic rocks is a layer or, more probably, the filling-in of a wide fissure, consisting of great angular blocks of quartz and quartzite, the larger of which must weigh at least a ton, and perhaps even several tons. Mr. Cole and I first saw it on the sea-level some distance west of the Arches, where it looked like an Archæan conglomerate; but as it reappears high up the cliffs to the east, and can there be seen filling crevices in the basalt, it is clearly of later date. A small dyke not far distant has exactly the appearance of bedded sandstone. Behind Beinn an Aoinidh, at about 700 feet elevation, there is a considerable quantity of lignite, and a hundred feet lower, graphite is said to occur in the bed of a stream, though when I visited the spot, properly guided, we failed to find any.

‡ A large trunk of a coniferous tree, 5 feet in diameter, perhaps *Podocarpus*, has been enveloped, as it stood, in one of the flows of Trap to the height of 40 feet. Its solidity and girth evidently enabled it to resist the fire, but it had decayed before the next flow passed over it, for its trunk is a hollow cylinder filled with débris and lined with the charred wood. A limb of another, or perhaps the same, tree is in a fissure not far off. Macculloch, who was certainly a most keen observer, did not overlook this tree, which he described in 1819 in his 'Western Isles of Scotland,' vol. i. p. 368, pl. xxi. fig. 1. The trunk was thought to be in a vein of conglomerated fragments of Trap imbedded in a paste of the same. He had also ascertained the wood to be coniferous.

appear until an elevation of nearly 1000 feet is reached, and then only in thin beds. A little to the north a thin seam of coal with some sand crops out at 250 feet above sea-level, which latter about corresponds with the base of the Traps at this point. The Wilderness commences somewhere here, and within 200 or 300 yards is a singular outcrop of chalk rubble or *remanié* chalk and flint, at an elevation of 100 feet above the shore. The larger mass measures 19 feet 5 inches across, and is 12 feet 9 inches high; and the smaller one, a little to one side and slightly below the other, is 17 feet 8 inches along the base, and 8 feet 9 inches high. They are chiefly composed of nearly white, broken-up flints, in a matrix of chalk, but disposed as in pudding-stone, without the least trace of bedding. There is nothing visible under this except iron-stained rubble and basalt talus. I have seen no other chalk on this part of the coast, and this is certainly not *in situ*, but as much a redeposited mass as the flint gravel of Carsaig. A little to the north of this we find the base of a cherty greensand *in situ*, but its thickness is not ascertainable. Immediately beneath this is Lias, 16 feet thick, formed of alternating clay and limestone bands, the latter with *Lima* and *Pecten*. Mr. Etheridge agrees with me in considering that this is a representative of the Lower Lias. Under this, again, is a bed of sandstone with green grains, which the bedding shows to be of marine origin, though it is unfossiliferous. Only a thickness of 15 feet is visible on the shore. Everything is unfortunately obscured by talus for a little distance westward, but the sands soon reappear with pebbles in them, forming a conglomerate precisely similar to that of Gribun, except that the materials are finer and more scattered.

This is interesting as showing that not only the red conglomerates of Gribun and Inch Kenneth, invisible here, but also the similar conglomerate with green grains above them, are of pre-Liassic age. This interpretation, which is the more natural one, deprives Inch Kenneth of any trace of Cretaceous deposits. Returning to the Wilderness, the gneiss now rises above the sea-level at a high angle, and gradually becomes higher and higher, until it exceeds 200 feet at Coireachan Gorma, where it forms the entire undercliff. The remainder of the section as far as Gribun I have only examined from a boat; but at the latter locality there is, as observed by Judd, unmistakable Upper Greensand over the Poikilitic conglomerate and marl, but, so far as I could discover, still no trace of Chalk. The Isle of Erisgeir, rather over two miles from the shore, is of gneiss; and Inch Kenneth is of gneiss and Poikilitic conglomerate.

Finding the Ardtun river-deposits so feebly represented on the opposite shore of Torosay, less than 2 miles to the N.E., and the presence of an elevated tract of Palæozoic and Secondary rocks there, I examined the traps running almost due east and west, along a line 12 or 13 miles long, embracing the north shore of Loch na Kael, and the Isles of Eorsa, Ulva, and Gometra. The Traps on the further side of the tract or ridge of Palæozoic rocks alluded to would appear to be the result of distinct flows, as on that side we find the lower levels occupied by rudely columnar and amygdaloidal basalts, instead

of the columnar flows hitherto seen. The lowest beds of amygdaloidal basalt at Burgh or Carsaig are in fact quite 300 feet from the base. The flows are also thickened and irregular on the shore opposite Ulva and in Eorsa, as if they had been piled up against the ridge, and they only become regular in Ulva itself and Gometra. Further, the ridge together with some of the first flows of Trap must have formed a lake-basin, for from the shore of Loch Tuath to that of Loch na Kael, a distance of over 2 miles, there are beds of bole and lithomarge, at least a dozen feet thick and pisolitic in places, cropping out among the basalts at heights of 100 feet or less above the sea. The beds are continuous and distinctly laminated, and the glacial beds over them are full of their fragments. These must have been formed in a small lake-basin; but I saw no trace of any gravels except the glacial beds, which everywhere cling to the sea-slopes, nor any beds which presented evidence of a fluvial origin. The course of the Ardtun river was therefore clearly not in this direction, and must have been to the south of Gometra. I was unable to explore the basalts round the north-west coast of Mull, but do not anticipate that any important beds of sedimentary origin would be met with.

Before leaving the district, however, I visited the sections on Loch Aline referred to by Prof. Judd (Q. J. G. S. vol. xxxiv. p. 734), where it seemed possible that plant-remains might be discovered. That part of the section between the gneiss and the columnar trap at Beinn nah Uamha (Beinn y Hun, *l. c.*) was everywhere obscured by talus; but the section at the south-east angle of Beinn Iadain was visible and substantially as described by Judd, except that the "Chalk," as at the Wilderness by Burgh, is not bedded, but *remanié* flints and chalk rubble only 4 feet thick. It does not appear to my mind to be sufficient to furnish absolutely convincing evidence that the sands beneath are of Cretaceous age; but it is a question foreign to our immediate subject and one which requires further investigation.

Though it is quite obvious that the sedimentary beds at Ardtun, no less than at Carsaig, are the ordinary gravels and muds of a river-channel, important differences between them become apparent when they are compared. At Carsaig their fluvial character was at once recognized by Prof. Judd; but those at Ardtun were believed by such experienced observers as Sir C. Lyell, Mr. Smith of Jordan Hill, and the Duke of Argyll to have had a volcanic origin. The examination which led to this conclusion was made, however, in a ravine where they appear to have been greatly affected by the passage of a dyke, and where their peculiar weathering and dark colour give them a truly volcanic aspect. On the sea front the current-bedding is as plain as in the river-gravels of England, and the block exhibited to the Society suffices to remove any doubt as to their true nature. At Carsaig we find a conglomerate of boulders of Trap and large flints resting directly on a Trap floor in one part of the section, flanked on the west by silts, and overlain by a vast mass of subangular flints of all sizes, scarcely even roughly sorted, the whole

being covered and overlapped by pure flint sand. Such an arrangement of material might have resulted from a mountain-stream of velocity sufficient to move rocks of relatively large size along its bed, giving place through changed gradient to a current not exceeding 5 or 6 feet per second, and no longer cutting away the basalts. Further depression seems to have converted it into a smoothly flowing river, with a current only capable of transporting grit and sand. The greatest width occupied by its bed does not appear to have exceeded a mile in this part of its course. The peculiarity of these gravels and sands is that they seem composed exclusively of angular fragments of flint derived from Chalk, without any other foreign substance. We may infer from this that the Tertiary Traps had no great extension southward, and I believe, in spite of their great thickness, that their present limits on that side coincide somewhat with their original confines. A considerable tract of hilly country must have been covered with Chalk.

At Ardtun the coarsest gravels are much finer than any gravel at Carsaig, and unlike the latter their small pebbles are imbedded in sand. The velocity of the currents which deposited them, even in the swiftest channels, must have been under 3 feet per second, while there were currentless backwaters depositing ooze or fine silt into which leaves of forest trees were eddied and sank. An increase in the volume of water ensued; for not only are the higher gravels more massive and of coarser material, but all backwaters and slow currents disappear, and the whole river-bed seems to have been occupied by swiftly moving waters. The transverse section through the gravels is not less than a mile, probably a mile and a half long; and though the section may be oblique, increasing the apparent width, the position of the lignites, &c., towards Bunessan and the Carsaig section, shows that the actual width was not far short of this.

The river may not have occupied the entire bed at any one time, but it was evidently one of magnitude when a renewed volcanic outburst filled in its bed with a massive flow of trap. It is interesting to remember that Prof. Geikie recognized the course of another of these Tertiary rivers in the Scur of Eigg, coming from a northern direction (Q. J. G. S. vol. xxvii. p. 309), while the interbasaltic sedimentary beds of Antrim furnish examples of still more considerable rivers flowing in the same direction.

Besides the difference in their coarseness, the gravels of Ardtun are distinguished from those of Carsaig by a large mixture of rolled pebbles of volcanic rocks, which may have come from the direction of Benmore, showing the influx of a tributary stream from a region of acid eruptions which had not been overwhelmed by the Traps. The central region of Mull appears to me in fact to have remained elevated during the Eocene, while the Traps were piled round its sides to a depth of 2000 feet*. A restoration of the

* This opinion is partly based on a careful survey of Beinn à Ghraig, a ridge of syenite between Benmore and Loch Bà, reaching a height of 1939 feet. The original mass is traversed obliquely by three gigantic dykes of felstone of slightly

contours about the river-gravels shows high ground to the south and east, coinciding with the boundaries of the Traps, with the river-channel roughly following the present outcrop of Palæozoic rocks in the Ross *. A spur of gneiss from Benmore, represented by the gneiss of Gribun, Erisgeir, and Inch Kenneth, directed its course westward, and we have seen that there is but a slight trace of it along the shore of Torosay. The actual river-bed is traceable for a little over 9 miles, and it ran in a north-west direction. There is but little hope of tracing it further in this area, unless fragments of its bed should by chance be preserved in the Isles of Bac Mor, the Dutchman's Cap, or in Lunga. I succeeded in getting near enough to the latter to see that there, at least, this is improbable, but continued high and adverse winds frustrated my efforts to reach the former. When we consider, however, that the preservation of Ardtun itself is mainly due to the accident that an intrusive sheet of great hardness runs through it and buttresses it at both ends, and that the presence of gravels would be a source of weakness and facilitate disintegration, we see that it is far more likely that its course is now under the sea than in the few islets that still remain above water. Indeed the

different quality, one in the centre and one at either end, in a direction almost parallel to the Sound of Mull. [That at the southern end, though provisionally called by the field-term of "felstone," is a hard, compact, black rock, weathering with a smooth white crust; under the microscope it shows a fine-grained matrix with porphyritic augites, and what appear to be numerous inclusions of another rock. Its specific gravity is as high as 2.90.—G. C.] It is probable that the syenite would long since have crumbled away but for the protection of the dykes, which weather slowly and act as supports. The mountain on the opposite side of Loch Bà is of precisely similar structure; but I omitted to state that there is in the first also a small dyke of gabbro and one of dolerite traversing the syenite. It seems likely that the crater of which Benmore is a fragment was formed at a later date, and after the Trap eruptions had ceased. So far as I could make out from this particular section, the syenite or granite region may have been a cluster of hills altogether outside any crater, and the felstone dykes may belong to any period antecedent to the Tertiary. It is impossible to say whether the Ross-of-Mull granite, which is red, is in any way connected with the syenite of Benmore, but there are boulders of a grey granite lying about, which seems, in some respects, intermediate between them. The Ross-of-Mull granite is perhaps not far off at a low level and may be concealed by talus or vegetation; for the whole district as well as the shores of all the Lochs and of Ulva and Morvern are strewn with fragments of it. To suppose that this was carried by ice from the low ground of the Ross to the south-west during the Glacial period involves physical difficulty, while in that case it must have been accompanied by blocks of the intervening gneiss, which does not appear to me to be the case.

* It is a question whether the line of junction between the Traps and gneiss, west of Bunessan, is marked by a fault. At Ardtun we are close to the base of the Traps. On the coast, 6 miles due west of Carsaig, the actual junction shows the basalt with slightly upturned edge against the gneiss, which is perfectly riddled by small veins. There are no intervening secondary beds as shown in Macculloch's section. The manner in which the edge of the gneiss is penetrated by the Trap appears an argument against a fault, and we everywhere see evidence that the secondary strata were not only very locally and unequally deposited in this area, but that only patches of them remained at the time of the first Trappean eruptions. A downthrow of from 100 to 200 feet would in any case bury their entire thickness, and a fault of 1000 feet is unnecessary for the purpose.

low lands which the river must have sought would inevitably have sunk under the enormous weight of Trap poured out upon them ; and in this area at least it is highly probable that we have little more accessible to us than the flows which cling to the flanks of the hills.

The Flora of the Ardtun Leaf-beds.

Considerable collections from these beds were made some 35 years since and were deposited in the Museum at Jernyn Street and at Inverary. About five years ago Mr. Koch made a large collection, which he presented to the University Museum at Glasgow. No specimen was to be found in the British Museum or in the Edinburgh Museum, and the flora was equally unrepresented in even the most complete of our University and great provincial museums. The collections that did exist were from the beds shown in figure 3, and the bed marked *d* in figure 6, the matrix, in most cases, being a crumbling black shale, in some a hard grey rock ; and the specimens of leaves were, with few exceptions, of a fragmentary description. I first endeavoured to supplement these in 1883 and 1884, but it was not until 1885 that regular quarrying operations were undertaken, with the result that large and perfect specimens of the chief types have been procured in abundance, and are now in the British Museum. One specimen in particular, nearly a yard in extent, shows several forms of *Platanites* and fronds of *Onoclea* in perfect preservation. Whilst collecting these, I excavated the beds marked *f* to *i* in fig. 6, which, though apparently observed by the Duke of Argyll, were at that time regarded as inaccessible. The layer *g* is a limestone as finely grained as that at Solenhofen, and contains impressions of leaves as beautiful as can be imagined, though it is unfortunately refractory and breaks with a conchoidal fracture, which baffles the search for fossils in it unless extreme care is used. Even when found, the absence of cleavage-planes makes it difficult and tedious to expose them. On the other hand, square yards at a time may be exposed of the underlying pale grey clay, completely covered with magnificent-looking leaves, preserving the colours proper to them when they sank waterlogged in the stream ; but here disappointment attends every attempt to remove them, for the clay instantly breaks up into pieces a little bigger than dice, and continues to crumble. The mere sight of such masses of leaves is most instructive, and from notes taken on the spot I am able to speak of the relative abundance of species, their variation, colour, and the maximum sizes attained by them. I also ascertained by this means that our knowledge of the flora is still relatively very imperfect. We are, however, now in possession of a large number of specimens, especially from the limestone, the nature of which I have endeavoured to convey in the accompanying Plates (Pls. XIII.-XVI.), in which only those of moderate size could be included.

The beds share a peculiarity possessed by most of the Eocene plant-beds in England, namely the absence of traces of aquatic life. It is difficult to come to any conclusion regarding the cause of this ;

for we can hardly suppose that bodies of water so considerable as those which deposited these, or the Reading or Bournemouth beds, were destitute of fish and molluscos and insect life. Of the latter, in its terrestrial form, we have, as usual, scanty traces. The most interesting is a detached wing in which the neuration and colouring are beautifully preserved, and which appears to be in all probability the hind wing of a Cercopid of an extinct type (Pl. XIII. fig. 9). Fig. 8 shows part of the wing-case of a beetle which has adhered to the matrix so that only the inner side is visible. One or two smaller elytra have been found in the black shale.

Only one species of Fern is known, *Onoclea (Filicites) hebridica*, Forbes, of which specimens have now been discovered, showing that the barren fronds were larger and on a stout rachis, and also exhibiting the fertile fronds which had not previously been met with*. The only other vascular Cryptogam in the flora is *Equisetum Campbellii*, Forbes, but both this and the *Onoclea* are undistinguishable from living species. There are also but few indications of cellular fungi on the leaves, and I am inclined to look upon this as one among many indications of relative antiquity.

Among Gymnosperms the *Ginkgo* is by far the most abundant, and its leaves form a considerable proportion of those seen in the clays. *Podocarpus Campbellii*, J. S. Gardn., comes next, and is interesting as being so far the most northerly representative of the genus, either living or fossil. A third is *Taxus Campbellii*, Forbes, a Yew strongly resembling *Taxus adpressa* of Japan†. Fig. 1, Pl. XIII., represents foliage more nearly approaching specimens from Atanekkerdluk, in Greenland, determined as *Sequoia Langsdorfii* by Heer; and fig. 2 would appear to belong to his *Glyptostrobus europæus*. Fig. 3 shows a small fruiting branch, which indicates the presence of a second species of *Podocarpus*, with short falcate leaves arranged spirally, and small berries, scarcely exceeding the eighth of an inch in diameter, borne in small terminal clusters. The foliage is not uncommon in the black shales; and in the absence of any evidence regarding the fruit, I had provisionally placed it with the Ballypalady *Cryptomeria*, which it very strongly resembles. The occurrence of this beautifully preserved twig in the white limestone, still retaining its shining black berries, is one of those fortunate circumstances which encourage the collector of fossil plants to persevere, even when the collection of leaf-forms from a bed seems to be well-nigh complete. I can find nothing nearer among the living Podocarps than *P. cupressina*, R. Brown, from the Philippines and Java.

There are no Monocotyledons beyond a liliaceous-looking leaf and a few reed-like stems.

The Dicotyledons are abundant, and the collections include more than thirty distinct species, most of them so adequately represented that the range of variation in the leaf is practically ascertained. Foremost among them is the splendid form *Platanites hebridicus*,

* Journ. Linn. Soc., Bot. vol. xxi. pl. xxvi.

† "Eocene Flora," J. S. Gardner, Monogr. Pal. Soc. vol. ii. 1884 and 1885.

Forbes, the leaves of which attained the large size of 15 inches, measured from base to tip. The variation in shape among them is very great, and might give rise to numbers of species, for the forms of the lobes and the serration differ so widely that mere fragments could hardly be identified. The external resemblance of the leaf to *Platanus* is very superficial, and Prof. Forbes's determination was confessedly a mere guess, for the fragments he had to deal with bore at least an equal resemblance to the leaves of many other kinds of plants; but in 1885 whole slabs of limestone were found to be covered with innumerable minute seed-like bodies (Pl. XIII. fig. 14a, magnified); and in other cases clusters of small globular catkins were found (Pl. XIII. fig. 15). Last year the specimens figs. 13 & 14, showing the catkins in the act of breaking up, supplemented these and proved them to belong to the same plant. The small bodies were recognized immediately, and quite independently, by Mr. Carruthers and Prof. Oliver, as the anthers of a *Platanus*. We thus find the male flowers in enormous abundance; but fig. 12 represents the only object resembling the female, a fact the more singular as it is precisely reversed at Reading, where leaves of *Platanus* also abound. The leaves occur in great profusion, especially in some of the layers of black shale. They have been collected at Atanekerdluk, but of much smaller size, by Whymper, Colomb, and others, and being wholly different from any Miocene form, should bear the name given by Forbes. Another very fine and undescribed form occurs in the Limestone; and a rarer leaf in the black shale which is common at Atanekerdluk, and has been called *Quercus platania*, and apparently also *Pterospermites spectabilis* and *P. alternans*, by Heer. Among the large leaves in the clays, seen but not collected, appeared to be forms like those described from Atanekerdluk as *Viburnum multinerve*, *Alnus Kefersteini*, *Magnolia Inglefieldi*, &c., from Greenland, but of relatively much larger size.

The only other lobed leaf in the flora is the *Acer*-looking leaf (Pl. XIV. fig. 1), of which the smallest and most exquisitely preserved specimen is figured. There is nothing resembling the *Liquidambar* or *Sassafras* found in the Atanekerdluk level of similar age.

Among the ovate-serrate leaves, that called *Corylus Macquarrii* by Heer, Pl. XV. fig. 3, is the most striking, and occurs most commonly in the Limestone. It is of a dark brown colour, and certainly resembles the hazel in a striking degree. Thin pellicles occur, Pl. XIII. figs. 5, 6, 10, in the same beds, with parallel and forking venation, which might be fragments of the husk; but the total absence everywhere in the Eocene of anything like nuts, and their abundance in the Pliocene, renders it difficult to believe that the genus *Corylus* was actually in existence during early Tertiary periods. The leaf form recurs in many genera, and we must probably look elsewhere for an acceptable determination. The same doubt, and for the same reasons, extends to all the determinations of *Cupuliferæ* from the older Tertiaries, except the *Betuleæ*, and also to those of the *Juglandææ*. The *Corylus*-like leaf is found very commonly at Atanekerdluk, and the species might be known provisionally as *Corylites Macquarrii*.

A new and very rare leaf at Mull is perhaps identical with the *Quercus grœnlandica*, Heer, from Atanekerdluk, some of the specimens of which seem, however, to have been placed in *Castanea Ungerii* by that author, though they do not resemble the Miocene Chestnuts of either Europe or America. The specimen is illustrated, Pl. XIV. fig. 2, and the species I would suggest should for the present bear the name of *Quercites grœnlandicus*. There is another very fine *Castanea*-like leaf in the limestone, which is too large to illustrate. We also appear to have forms identical with those erroneously described as *Alnus nostratus*, *Viburnum Whymperi*, and *Carpinus grandis*, together with the forms figured, Pl. XIV. fig. 3, Pl. XV. fig. 2, and Pl. XVI. fig. 1, which as yet seem peculiar.

Among the leaves with highly characteristic venation are the *Zizyphus hyperboreus* or *Paliurus borealis* of Heer, both of which belong probably to the same species, *Populus Richardsoni* and *P. arctica*, which also seem to be undistinguishable, and *Cornus hyperborea*. Perhaps the most beautiful and distinctive leaf-form, however, in the whole flora is the exquisitely marked leaf with triple midrib and crenated margin shown on Pl. XV. fig. 1. The colour on the face is pure white, with veins black, but on the back the whole leaf is plum-colour. These strongly marked characters seem to justify us in regarding it as a species of *Bœhmeria*, of the Urticææ, and may even serve to identify it with an existing species of Japan. I propose for this species the name of *Bœhmeria antiqua*.

There are, in addition to these, a number of simple ovate leaves resembling those of the Bay and Laurel, &c., Pl. XVI. figs. 2, 3, 5, as well as the *Rhamnites* of Forbes; but it seems scarcely probable that any of these are capable of generic identification from the leaves alone.

The flora is distinguished, like all those of early Eocene and Cretaceous age, by the absence of the so-called Cinnamon-leaves and the *Smilacææ*, which always enter into the composition of Middle Eocene and Oligocene floras rather largely. There is, in fact, not one type characteristic of the Middle Eocene, Oligocene, or Miocene in England or Central Europe to be found in it, and it shares with all floras of similar or earlier age the peculiar facies given by the complete absence of leguminous pods*.

The Ardtun deposit is known to be of newer age than the Chalk of the same area, because it includes material derived from it; and in the absence of evidence linking it with any later stage of the Cretaceous, it must be regarded as Tertiary†. The particular stage to which it must be assigned has to be determined chiefly on the evidence of the fossil plants contained in it. It will be seen that though we cannot exactly parallel the Ardtun flora with anything else, its general facies is more that of a Cretaceous flora than of a Tertiary one, and that its most characteristic types ceased to exist

* The only figure throughout the 'Flora Arctica' purporting to be part of a fruit, "*Leguminosites*, sp.," is a torn fragment, which might equally be part of a leaf.

† In the Trans. Edinb. Geol. Soc. vol. i. April 1867, Mr. T. Smyth maintains that the Lower Basalts of Ardtun and of the sides of Fingal's cave in Staffa are Upper Cretaceous, and the leaf-bed of Ardtun, Miocene.

in Europe with the stage known to continental writers as Paleocene. Further, if we accept the stratigraphical evidence linking it to the floras of Antrim, we are able to fix the age of the next overlying flora as not later than that of Gelinden, a flora of 'Heersien' age, and probably contemporary with our Thanet Beds* ; and to check this by a third and much newer flora, that of Lough Neagh, in which for the first time the most characteristic plants of the Middle Eocene make their appearance. This evidence, complete as it is, is backed by a large amount of negative evidence, and must carry conviction, unless it is denied that plants in those days followed the ordinary laws of nature and appeared in any definite sequence.

Thirty-five years ago, when the Ardtun flora was brought under the notice of the Society, scarcely anything was known about fossil plants. The existence of Dicotyledons of Cretaceous age was not even suspected, and except the abnormal flora of Sheppey not a single assemblage of plants of acknowledged Eocene age had been adequately illustrated, while the monographs on Tertiary plants in all did not reach ten in number. The science was in its infancy when Edward Forbes hazarded the opinion that the plants would prove to be of Miocene age ; and those who have been accustomed to regard the age of the Ardtun flora as no less well established than that of Alum Bay will be surprised to realize the slender basis on which the determination has rested.

The first notice of the occurrence of fossil plants in these Traps was published by the Duke of Argyll in January 1851 †. Though well aware that they were of Tertiary age, he refrained from making any more definite statement regarding them ; but Prof. E. Forbes, to whom the task of describing the plants themselves fell, thought "that the general assemblage of leaves, when judged by the present state of our knowledge of the vegetation of ancient epochs, is decidedly Tertiary, and most probably of that stage of Tertiary named Miocene." He was unable, however, to identify any of them, either with forms of the British Eocene ‡ or European Miocene, and was forced to regard them as "in all probability distinct from any recorded species" §. One, however, *Platanites hebridicus*, he believed to have "a close affinity with *Platanus hercules* ||, from the marly slates of Croatia;" and another *Taxites? Campbellii*, "allied to the *Taxites Rosthorni* of Unger, from the Miocene lignite of Carinthia." The remaining six species (really only four) presented apparently no sufficiently decided resemblance to any previously known form to be worth alluding to. We thus see that, when describing them, Forbes was only able to say that the small fragments of *Platanites*, which were all he had, were something like an *Eocene* form from Croatia,

* Geol. Mag., April 1887.

† Quart. Journ. Geol. Soc. vol. vii. p. 89.

‡ L. c. p. 103.

§ The known British Eocene floras appear to have been the abnormal ones of Sheppey and Alum Bay, which certainly bear no resemblance to that of Mull.

|| Unger, 'Chlor. Protog.,' p. 138, t. 46. They belong actually to very distinct types of leaf. The slates were described as Eocene.

and the *Taxites*, a yew-like conifer of a type actually common to every flora, from the Jurassic upwards, was something like a *Miocene* conifer from Carinthia.

The next reference to the Mull flora that I have traced occurs in Lyell's 'Elementary Geology,' 5th ed. 1855, p. 181, where the author says, "no accompanying fossil shells have been met with, and there seems therefore the same uncertainty in determining whether these beds are Upper Eocene or Miocene, which we experience when we endeavour to fix the age of many continental Brown-Coal formations, those of Croatia not excepted." Jukes, Phillips, and other contemporary writers make no mention of the Ardtun plants, and no very definite opinions concerning them seem to have been formed until 1856, when De la Harpe visited England.

He wrote, after examining them, that though most of the impressions are hardly determinable, and he is unable to identify any with known species, he fully coincides with Forbes's opinion, and can only regard them as a *Miocene* flora*.

In 1859 Heer pronounced them to be *Miocene*, though he had not seen the specimens, and had only the rather defective figures of Forbes's very imperfect specimens to go upon; yet this opinion seems to have been regarded as final, and has remained uncontradicted to the present day. What he actually said was † that Ardtun Head was the only point in Great Britain which had until then yielded *Miocene* plants, amongst which were *Sequoia Langsdorffii* and *Platanus aceroides*, Gp. (?). In a footnote (p. 314) he is more explicit ‡; but we see that the *Taxites* of Mull has shorter leaves than the *Sequoia* it is identified with; the *Platanus* is only *very probably* the *P. aceroides*, the imperfect preservation of the margin leaving room for *some doubt to exist*; the *Alnites* is *perhaps* the *Corylus*; the *Rham-*

* "Quoique la plupart des empreintes recueillies soient peu déterminables et que je n'en puisse rapporter aucune à des espèces connues, je partage pleinement l'opinion de M. Forbes, et n'y vois aussi qu'une florule de l'époque Miocène. La présence d'un *Alnus*? (*Alnites*? *MacQuarrii*, Forb., pl. iv. fig. 3); celle (probable) d'un *Acer* (*Platanites hebridicus*, Forb., pl. iii. fig. 5, et pl. iv. fig. 1), voisin de l'*Acerites integerrimus*, Viv.; et celle d'un *Rhamnus* (*Rhamnites*? *multinervatus*, Forb., et *Rhamnites*? *major*, Forb., pl. iii. fig. 2 et 3); enfin, la position géologique du gisement sont autant de motifs en faveur de cette opinion." (Bull. de la Soc. Vaudoise, 1856.)

† Flora Tert. Helv. vol. iii. p. 313.

‡ "Der *Taxites Campbellii*, Forb., ist die *Sequoia Langsdorffii*; die Blätter sind zwar etwas kürzer als sie bei unsern Exemplaren gewöhnlich vorkommen, doch finden sich solche kurzblättrige Formen auch bei uns und in Oestreich (cf. Unger's 'Iconogr.' Taf. 15. fig. 13). *Platanus hebridicus*, Forb., ist sehr wahrscheinlich *Pl. aceroides*, Gp. Das Blatt hat nur 3 Hauptnerven (kann daher nicht zu *Acer integerrimus*, Viv., gehören) und überhaupt ganz die Nervation der genannten Platane. Leider ist aber der Blattrand nur an wenigen Stellen erhalten, und so bleibt immer noch einiger Zweifel; sonst müsste der Name von Forbes als der ältere vorangestellt werden. Taf. 3, fig. 4, gehört vielleicht zu *Corylus grosse-dentata*, Hr. Die Randbildung ist wahrscheinlich unrichtig gezeichnet. Taf. 3, fig. 2 (*Rhamnites*? *multinervatus*, Forb.), ist wohl *Berchemia multinervis*, A. Br., sp. Die merkwürdigste Art ist der *Filicites*? *hebridicus*, Forb., ein Farrenkraut, das in seiner Nervation sehr von allen des Continentes abweicht."

nites is probably the *Berchemia*; the Fern is of a type unknown on the continent. He thus differs in detail from De la Harpe, and is indisposed to admit that the flora contains either *Alnus*, *Acer*, or *Rhamnus*, the presence of which had convinced the latter as to the Miocene age of the flora. His four rather hesitating identifications sufficed, however, to induce him to speak even more positively than De la Harpe, who had at least seen the specimens, as to the age of the beds; but he reduces the value of his evidence by only admitting two, the *Sequoia* and the *Platanus*, into the exhaustive tables which conclude his great work on the Tertiary Flora of Switzerland. I cannot trace that these identifications were in any way increased or modified after Heer's visit to England; but in 1862 he changed the name of *Corylus grossedentata*, of the Aquitanian of France and Switzerland, to *Corylus MacQuarrii*, Forbes, sp.*

This completes the evidence upon which the Miocene age of the Basalts was defined; for in the 6th edition, 1865†, and all subsequent editions of Lyell's 'Elements,' and 'Student's Elements of Geology,' we find the following:—"and his [Forbes's] opinion has been confirmed by Prof. Heer, who found that the Conifer most prevalent was the *Sequoia Langsdorffii*, also *Corylus grosse-dentata*, a Lower Miocene species of Switzerland and of Menat, in Auvergne."

Thus the age of the beds has been based on the lithographs of four species, wanting in detail, and represented by mere fragments of leaves, which even De la Harpe, who was not easily discouraged, regarded as "*peu déterminable*," the specimens being, in fact, in black shale, and by no means easy to make out.

A letter from Heer to Ch. Gaudin, dated 1856, published in the Bull. de la Soc. Vaudoise, shows that the only floras recognized by him as Eocene at that period ‡ were known to him from the descriptions, without illustrations, published by Gaudin and by Brongniart, from Bowerbank's work on the English Eocene plants, and the flora of Monte Bolca. All others, though described as Eocene in published works, he regarded as Miocene §. It is easy to see how, with the ordinary types of Eocene floras (and some of the isolated Swiss floras may be Eocene), grafted on to the Miocene floras, there was always at hand a scale by which every flora, except such abnormal ones as those of Sheppey and Alum Bay, would be determined to be Miocene, and be of use in turn in incorporating floras of even more widely different ages. On the plant-evidence, Heer would have pronounced the Reading and the Bournemouth floras to be Miocene had they been known then; for they have a very large number of species in common with European floras he had already so placed. He did, in fact, pronounce an American *Cretaceous* flora sent him to be Miocene, so that it is obvious he was not in a position to offer any sound

* Naturf. Gesellsch. Zürich, 1862, p. 178.

† Lyell, 'Elements,' ed. 6, p. 239.

‡ "Où est donc la flore éocène?—Je n'en connais pas ailleurs qu'au Monte Bolca, en Angleterre, et dans le bassin de Paris."

§ "Cet examen m'a parfaitement confirmé l'opinion que Häring, Sagor, Sotzka, Radoboj, de même que le Monte Promina sont *miocènes* et non point *éocènes*." (Bull. Soc. Vaudoise, 1856.)

opinion regarding the age of any of the older Tertiary floras, even with the best of material.

There are, moreover, many prevailing types of leaves common to widely distinct genera which seem to occur in most floras, whether recent or fossil. The so-called *Corylus*, on which so much stress has been laid, is one of such; for even the brambles and hazels in any hedgerow are seen to have the same cutting and venation. The identifications of the Mull and Greenland plants with those of European Miocenes will be seen to rest upon leaves of this kind, and not upon the well-characterized forms, which differ most completely. Instances of similarity, and even identity, between the Greenland plants in question and those of the Cretaceous and older Tertiary floras of Europe have passed without comment, whilst the majority of the identifications actually made are untrustworthy, for in nearly every case there are marked and often fundamental discrepancies between the form and venation of the leaves compared.

Of the Ferns, the oldest are unknown in any other European formation, though the Ballypalady type appears in the 'Heersien' of Gelinden and the Woolwich Beds of Bromley; but directly the newer beds of Lough Neagh are reached two widely spread Middle Eocene types appear (Journ. Linn. Soc., Bot. vol. xxi. pl. xxvi.). Of the Coniferæ, the only one to reappear in any post-Eocene deposit of Europe is the still living *Ginkgo*, which recurs in the late Miocene or Pliocene (?) of Sinigaglia, in North Italy. It is upon the Dicotyledons, however, that reliance has chiefly been placed; and it is likely that their evidence is the more trustworthy, since they must have been undergoing somewhat rapid modification in the direction of existing species and genera.

The first fossil plants brought back by Arctic expeditions were from the lower of the two plant-beds at Atanekerdluk, in Greenland; and collections from this were made by McClintock, Colomb, and Whymper. They were determined by Heer to be Miocene, and comprised not only all the plants from Ardtun illustrated by Forbes, but most of those since discovered by Baily at Glenarm and Ballypalady, in Antrim. Fifty-two out of the 178 species* from this bed were identified with European or American Miocene plants, and these we propose to examine, since the evidence in support of the Miocene age of the Ardtun plants alone would scarcely require further consideration; whilst if the Atanekerdluk bed is really Miocene, the Ardtun bed would be equally so. The Atanekerdluk bed is 1200 feet above the sea, and under a great capping of basalt; most of the leaves were found in a reddish concretionary ironstone like that of Lough Neagh; and others, less distinct, in dark shale and a yellowish ochreous sandstone. A second plant-bed occurs 200 feet above, with considerably more than half its 78 species peculiar to it, and much less like those of Mull and Antrim. Since then fossil plants

* At least one half of these should be suppressed. Robert Brown, the companion of Whymper, was the first naturalist to visit these beds, and he strongly protested against the "reckless way Heer makes species and genera out of these fossils." Trans. Edinb. Geol. Soc. vol. i. p. 194 (1868).

have been collected from more than forty fresh localities within the Arctic Circle, some of which are obviously of much later age, and which we need not now take into account.

The most conspicuous of the leaves at Ardtun, both on account of its size and abundance, is the *Platanites hebridicus*, Forbes, identified by Heer*, first with *Platanus aceroides*, Göppert, of Schrotzburg, and subsequently with *P. Guillelmæ*, Göppert, of Schossnitz †. The materials for comparison were the two figures in the Journal of this Society, neither of which show base, apex, or margin, and some hardly more perfect specimens from Greenland, the fragments of different leaves brought home having, it is stated, to be pieced together to get an idea of the leaf. The fine series of perfect specimens which we now possess shows that Forbes's species differs in nearly all its details, and is a much larger form than any of the Miocene species of *Platanus* of either Europe or America, and greatly resembles the Cretaceous *Credneria*, as observed, indeed, by Heer, as well as some of the Sézanne leaves of Paleocene age.

Castanea Ungerii, Heer, *Fagus castaneæfolia*, Unger, from the Miocene of Leoben and Wartzberg, in Styria, &c., and of the American Miocene, is a handsome species and probably a true *Castanea*; but the cutting of the leaf in the Greenland specimens identified with it is different, and the fruits ‡ which are cited in support of the determination are far more like the similar bodies from Ballypalady than like chestnuts. *Fagus macrophylla*, Unger, is identified as a Greenland fossil on an indistinct fragment of a leaf which differs in no respect from the above; whilst the leaf named *Quercus furcinervis*, Rossm., is probably only another specimen of the same species, and differs widely from any leaves of the Swiss Molasse or the American Miocene bearing that name. The supposed *Planera Ungerii*, Ett., of Greenland, is represented by a single specimen, which might well be a distorted form of the same so-called *Castanea*; and neither its form, cutting, nor venation justify its association with the well-marked Miocene form, so prevalent in the Molasse &c. of Switzerland, Germany, and Italy.

The supposed *Carpinus grandis*, Unger, of Greenland and Mull, is a leaf with different cutting, and veins much wider apart and more forked than the Swiss or American forms.

Quercus Drymeia, Unger, is a species well known from the Middle Eocene to the Oligocene; but there is nothing in two fragments from Greenland to justify their reference to it.

The same remarks apply to *Salix varians*, Göpp., and to the single imperfect and characterless leaf identified with *Rhamnus Rossmässleri*.

The specimens ascribed to *Juglans acuminata*, A. Br., are imperfect leaves without decided characters, which do not resemble in any definite way the splendid specimens figured by Heer under that

* Flor. Tert. Helv. vol. ii. p. 71.

† Göppert, 'Die Tert. Flora von Schossnitz in Schlesien,' 1855, p. 21.

‡ Flor. Arct. vol. ii. pl. xlv. figs. 2-2 b.

name in the 'Flora Tertiaria Helv.' (vol. iii. p. 88, pls. 128 and 129), and they would be better placed under *Magnolia Inglefeldi*, Heer.

Corylus Macquarrii, Forbes, so very abundant in Mull, is probably distinct from the Miocene *C. grosse-dentata*; while the single smaller leaf, separated as *C. insignis*, is only a smaller specimen of whatever the larger ones may prove to be.

The fragment referred to *Liquidambar europæum*, A. Br., has no perfect digit, and the secondary veins are obliterated. The Greenland *Diospyros brachysepala*, A. Br., agrees with the form described by Lesquereux from the Eocene Lignitic, but not with that of the Swiss Miocene.

Several distinct forms seem to be described under the name of *Salix Raeana*, Heer, but only one of them recurs among the figures of Baltic Miocene (?) plants.

Quite a small fragment of a leaf and two indistinct fruits are referred to *Myrica acuminata*, Unger; but they may belong to some plant widely distinct from that of Sotzka or the Baltic floras, while those placed by Lesquereux in the species are exactly like *Quercus Drymeia*. The tiny leaflet called *Colutea Salteri* is very unlike in all respects those figured in the 'Flora Tert. Helv.' (pl. 132. figs. 60 and 61). *Populus Zaddachi*, Heer, is only represented from Greenland by imperfect leaves, which probably may be identical with those from the Amber-beds. The leaves from the Baltic, the American Lignitic, and from Greenland, referred to *Fracinus denticulata*, Heer, and those from Bovey Tracey, Missouri, and Greenland, referred to *Quercus Lyelli*, Heer, I believe in each case to be distinct forms.

The foregoing species are all stated to be common to the Miocene formations of Greenland, Europe, and America. Those which follow are supposed to be confined to Greenland and America and Greenland and Europe respectively. In the former category we have *Populus arcticus*, Hr., and *P. Richardsoni*, Hr., which I cannot distinguish from each other, from Greenland, Mull, and Reading, with leaves large and deeply notched, and from America, small and smooth, or slightly notched. *Hedera MacClurii*, Hr., is based upon such fragments that comparison is impossible. The fine leaf, *Vitis Olriki*, Hr., of Greenland, is not accepted by Saporta as a vine, and I do not see justification for Lesquereux's association with it of leaves from the first and second stages of the Great Lignitic. The grounds for separating specimens called *Quercus Olauseni* from those called *Castanea Ungeri*, Hr., seem inadequate; while neither of the three very different leaves placed under *Juglans denticulata*, Hr., agree at all closely with the same species, according to Lesquereux. On the other hand, the examples of *Paliurus Colombi* of Heer and Lesquereux appear to be properly united.

Of the species common to Greenland and Europe, *Andromeda protogæa*, Unger, and *A. Saportana*, Hr., are not identified in the Greenland beds on adequate grounds. *Acer otopterix*, Göpp., is recognized from a fragment devoid of outline. The parts of leaves assigned to *Populus Gaudini*, Fischer, might belong to *Magnolia* or

any other form. The specimen named *Sassafras Ferretianum*, Mass., though very fragmentary, is far more like a leaf from Dulwich and Newhaven than the Italian species. *Fagus dentata*, Unger, is represented in Greenland by a few fragments, and *Fagus Deucalionis*, Unger, by one insignificant shred of the same type as others called *Castanea Ungerii*. *Dryandra acutiloba*, Brongn., ranks as a Greenland species on account of another insignificant fragment, and veins are introduced into the figure which heighten the resemblance, but do not exist in the specimen. *Rhamnus Eridani*, Unger, is based on a good specimen, but without distinctive character: *Rhamnus Gaudini*, Hr., on a fragment which is alike destitute of base, apex, and margins, and in which even the veins are differently disposed from those of the Swiss specimen; and *Rhamnus brevifolius*, A. Br., from Switzerland, is quite distinct from that of Greenland. *Juglans Stroziana* and *Quercus Laharpii*, Gaudin, from Greenland, are mere fragments devoid of distinctive characters; *Cornus ferox*, Ung., is based on fragments too imperfect for comparison; and *Alnus nostratus*, Ung., on specimens just sufficiently distinct to show that they cannot belong to that species. Finally, the leaf determined as *Populus sclerophylla*, Sap., of Greenland, differs in every detail from the same species at Armissan.

These determinations are for the most part based upon specimens which I should regard, under any circumstances, as too fragmentary to be of any value, and belonging moreover to types of leaves which are so universal that they would, even if perfect, fall into the undeterminable residuum of a fossil flora. It would, I believe, have been just as easy to have identified them with either Cretaceous, Eocene, or living species as with Miocene. It is not a little significant that none of the finer and most distinctive plants of the Mull, the Antrim, or the Atanekerdluk floras in question were, or could be, identified with Miocene species, but were all admitted to be peculiar. Among these, we have the *Pterospermites* or *Quercus platania* (for these seem to be the same plant) represented by a magnificent specimen from Atanekerdluk in the British Museum, and a similar one from Mull in the Glasgow Museum, recalling the larger leaves of Sézanne. Then there is the very satisfactory *Magnolia Inglefieldi*, and the fine species named *Ilex longifolia* and *Quercus groenlandica*.

But the best marked and most thoroughly characteristic leaves of the whole are the *Daphnogene Kanii*, Hr., and the *MacClintockia trinervis*, Hr., forms which are equally represented in the Thanet flora of Gelinden and in the Antrim floras. These perhaps belong to the genus *Pilea* of the *Urticeæ*, but they evidently existed in Europe at one definite stage and no other, and afford palæontological evidence that should be conclusive. With these is the *Rhus bella* of Heer, identical with *Dewalquea gelindensis* of Gelinden, and a few other less distinctive forms.

The large number of fossil floras brought from Arctic regions have demonstrated that there is a gradual passage from those determined to be Cretaceous to those determined to be Miocene. The stratifi-

cation of these beds renders it in the highest degree improbable that beds of Eocene age should be unrepresented, whilst the known temperature of the Eocene would have been more favourable to the growth of temperate floras in high latitudes than the diminished heat of the Miocene. If palæontological evidence is to count for anything, the floras of Glenarm and Ballypalady must be correlated with the Thanet flora of Gelinden; the lower bed of Atanekerdruk is a little older, and the flora of Ardtun is a little older still. The relative stratigraphical positions of the Antrim and the Ardtun leaf-beds bear this out. The flora of Lough Neagh, which is the newest of the basaltic floras in Ireland, is, upon palæontological evidence, somewhere on the horizon of the Bournemouth and Bovey floras.

I have dwelt at some length on the illusory nature of the evidence upon which these floras have for so long been regarded as Miocene. The misconception as to their age was easy to propagate, but, after finding a place in every text-book of geology for 35 years, is hard to remove. If I have failed to attain this object, I am convinced that it is less from lack of evidence than from failure to arrange it in a convincing manner. No steps towards a rational appreciation of fossil floras can be made until the fallacies regarding their age are swept away; but when this shall have been accomplished, due allowance being made for differences of latitude and longitude, they may even surpass faunas in furnishing trustworthy data for determining the age of rocks.

EXPLANATION OF THE PLATES.

PLATE XIII.

Eocene Plants and Insects from Limestone of Ardtun; natural size, except fig. 14 a.

- Fig. 1. Coniferous foliage, resembling that from Greenland described as *Sequoia Langsdorffii*, Heer.
 2. Coniferous foliage, similar to that described as *Glyptostrobus europæus*, Heer.
 3. Fruiting branch of *Podocarpus borealis*, sp. nov. (p. 289).
 4. Flower-spike stem.
 5, 6, 10. Bracts or fragments of husks.
 7. Small drupaceous fruit.
 8. Elytron of a beetle.
 9. Hind wing of a Cercopid insect.
 11. Impression of a large subangular seed.
 12. Fruit of *Platanus hebridicus*, Forbes?
 13, 14, 15. Male catkins of ditto.
 14 a. Detached anthers, magnified.

PLATE XIV.

Typical Eocene Plants from Limestone of Ardtun; natural size.

- Fig. 1. Lobed leaf, a form usually ascribed to *Acer*.
 2. *Quercites granlandicus*, Heer.
 3. Ovate, serrate leaf, undetermined.

PLATE XV.

Typical Eocene Plants from Limestone of Ardtun ; natural size.

- Fig. 1. *Bœhmeria antiqua*, sp. nov. (p. 291).
 2. Ovate, serrate leaf, undetermined.
 3. *Corylites Macquarrii*, Forbes, sp.

PLATE XVI.

Typical Eocene Plants from Limestone of Ardtun ; natural size.

- Fig. 1. Ovate, serrate leaf, undetermined.
 2, 3, 5. Evergreen leaves, like those of *Myrtaceæ*.
 4. *Betula*-like leaf.

DISCUSSION.

MR. BAUERMAN, as Chairman, remarked upon the great interest attaching to the study of these deposits, upon which the Author had brought forward a most valuable series of observations and illustrations.

The PRESIDENT also bore testimony to the value of Mr. Gardner's collections. Referring to the points upon which the Author differed from himself in opinion, he said that when he visited the locality he was impressed with the fact that Macculloch had correctly described what existed then. He thought that the Author was mistaken in the significance he attached to "rubble-chalk." Rubble-chalk was not chalk transported, but broken up *in situ*. He considered that the presence of lignite in the unfossiliferous sandstones lying above the Upper Greensand was indicative of estuarine conditions.

MR. CARRUTHERS remarked upon the extreme value of the collections obtained by Mr. Gardner, but said that as the specimens had not yet been worked out, he could not venture to pronounce any opinion upon the evidence which they furnished.

MR. G. F. HARRIS remarked upon the age of the deposits, which he understood Mr. Gardner paralleled with the Heersian beds of Belgium ; and if this were so, the Mull beds in question would not be older than the Thanet of this country.

The AUTHOR, in reply, referred particularly to the small thickness of Chalk occurring in Mull, and stated that in the case of the "rubble-chalk," its being *in situ* or not seemed to him to be an open question. He would not deny that the Greensand deposits might be estuarine, but at the same time he thought that Macculloch had assigned this character to them upon hearsay evidence.





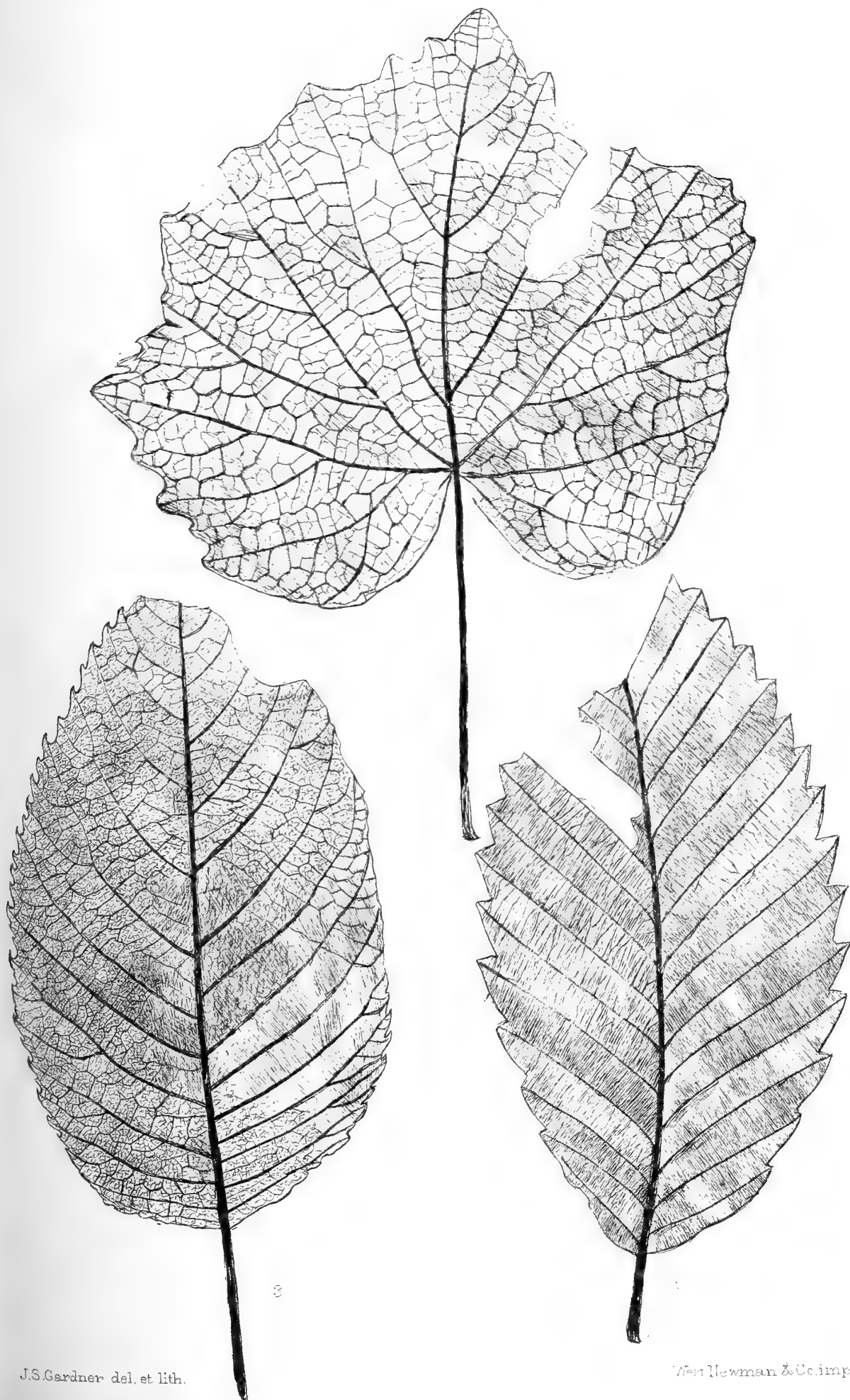

J.S.Gardner del. et lith.

West Newman & Co imp.

FOSSIL LEAVES FROM ARDTUN.



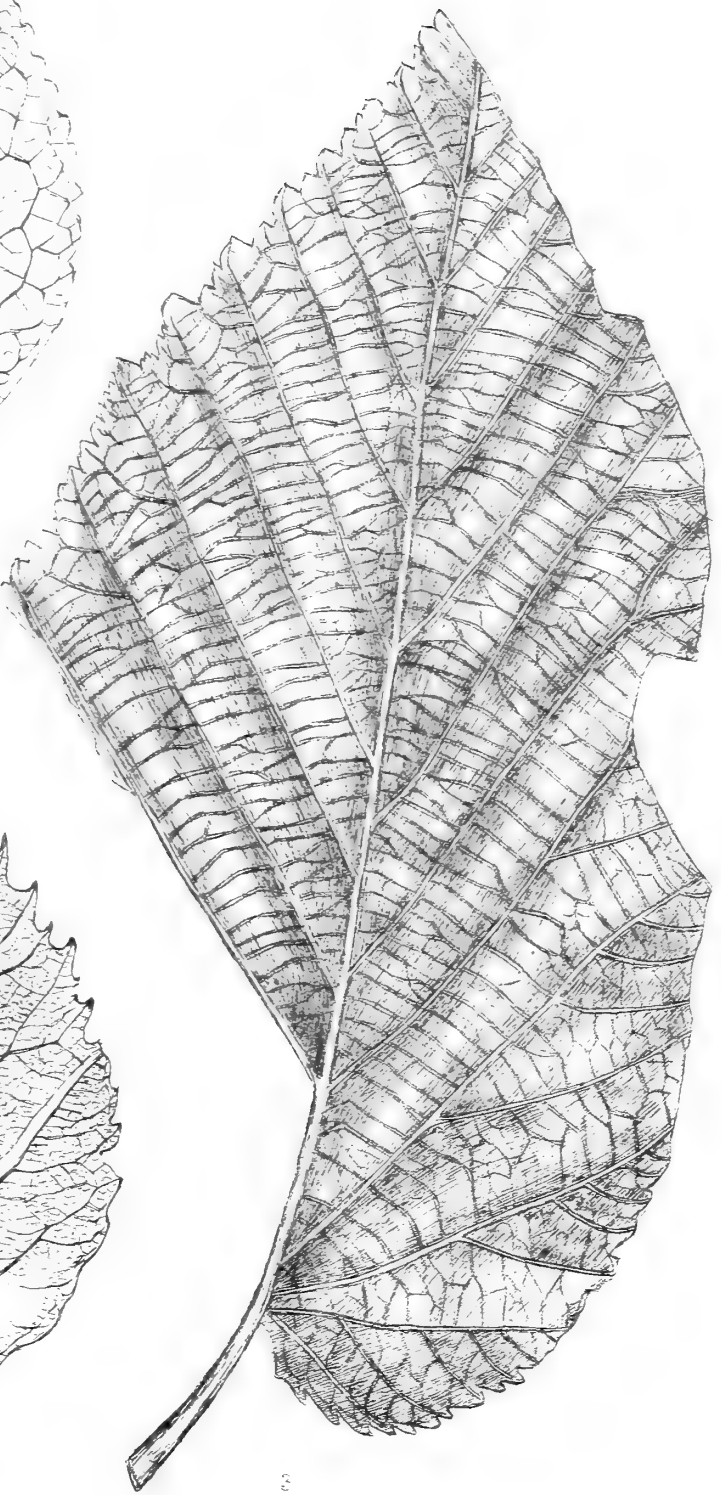
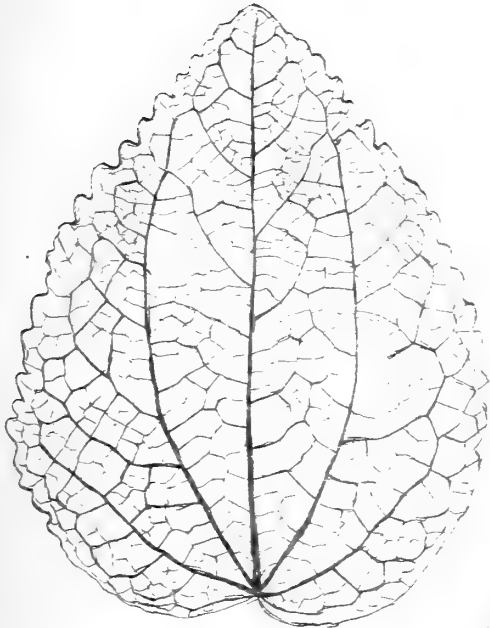

2

3

J.S. Gardner del. et lith.

West. N. M. & Co. lith.

FOSSIL LEAVES FROM ARDTON

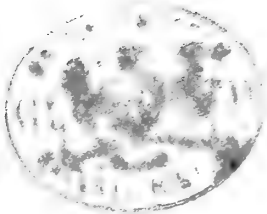

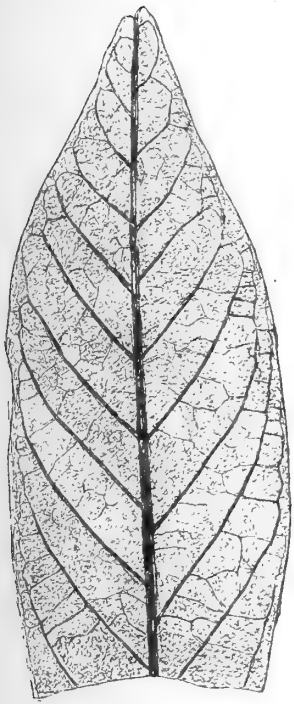

2

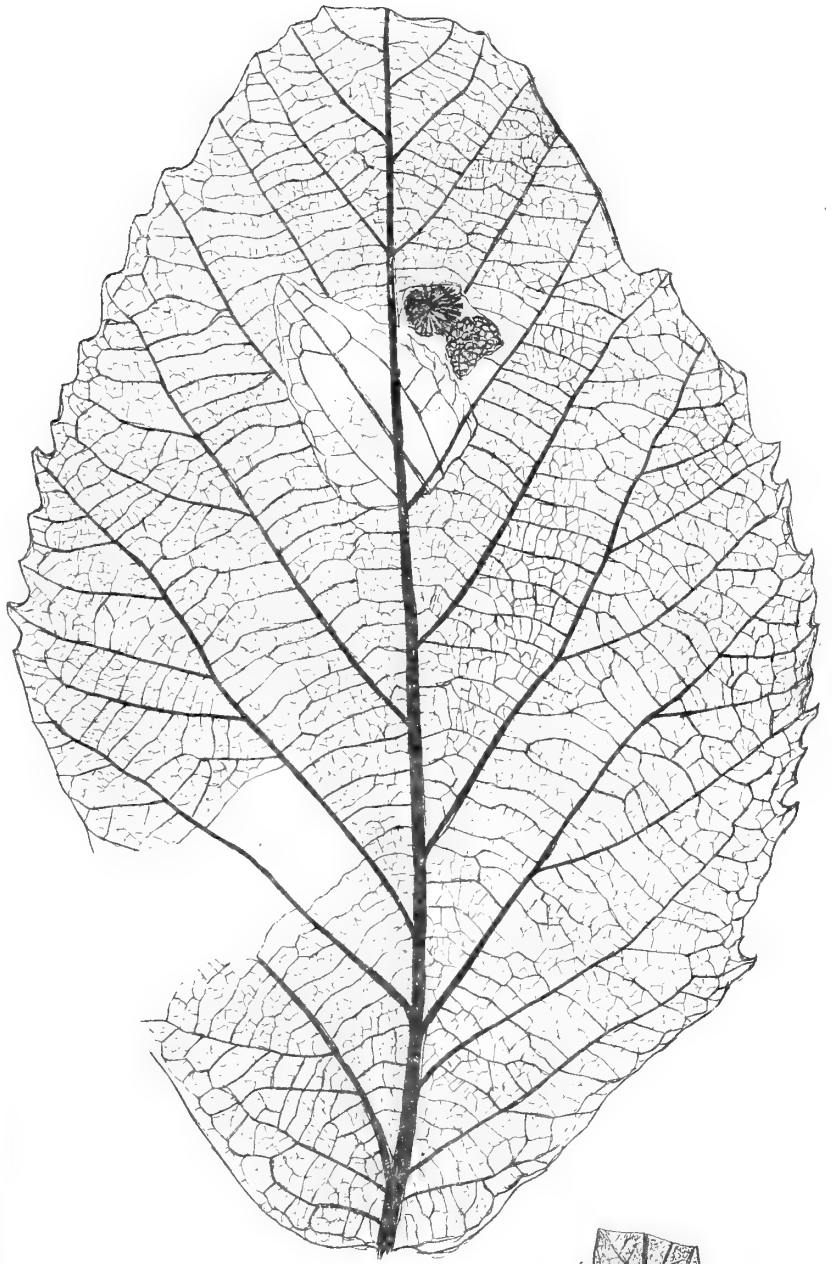

1

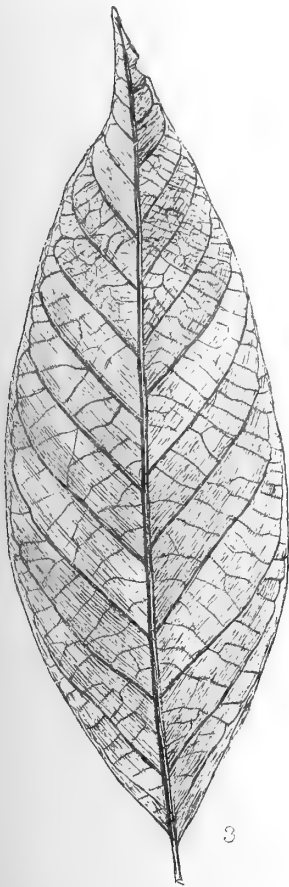

3



4

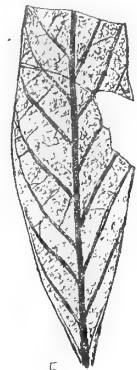

5

J S Gardner del. et lith.

West, Newman & Co imp.



23. NOTES on the STRUCTURES and RELATIONS of some of the OLDER ROCKS of BRITTANY. By T. G. BONNEY, D.Sc., LL.D., F.R.S., Professor of Geology in University College, London, and Fellow of St. John's College, Cambridge. (Read March 23, 1887.)

[PLATE XVII.]

SOME unavoidable engagements prevented me from availing myself of the cordial invitation of the Société Géologique de France to our Members, and joining their excursion to Brittany last summer. My friend the Rev. E. Hill was, however, more fortunate, and his account was so interesting that I determined to spend part of my autumn holiday in learning something of the geology of a country to which many years ago I had paid a flying visit for the sake of its antiquities. I am greatly indebted to Mr. Hill for the loan of specimens, and for a number of valuable hints, both verbal and manuscript. Even greater are my obligations to Dr. Charles Barrois, who, being detained by official duties in the neighbourhood of Redon, most kindly wrote to me several times, pointing out the best localities for study, and in subsequent correspondence has imparted to me his views in the most frank and cordial manner. Some excuse may perhaps be needed for writing at all upon a district which is in the hands of geologists so competent as the members of the French Survey. The impressions formed during a passing visit may not unreasonably be deemed of no value in the presence of their more elaborate work. But in one respect (as Dr. Barrois urged in writing to me) I may hope my remarks may be not without use. I did not go to Brittany to criticize, but to compare. I looked at its rocks in the light of other districts with which I am well acquainted, and sought to ascertain their bearing on general questions of metamorphism and the genesis of crystalline schists.

Three questions, then, were always prominently before me as I worked:—

(1) Among the crystalline schists what structures, if any, are presumably original? and what are due to subsequent disturbance primarily mechanical?

(2) What is the probable age of these schists? How are they related to, or in what respect do they differ from, beds indubitably Palæozoic?

(3) How far are both the crystalline and the sedimentary rocks affected by the more important intrusive igneous masses? and do the results in case of the latter resemble the schists and gneisses generally regarded as of Archæan age?

In regard to each of these questions Brittany supplies us with evidence which appears to me valuable.

I travelled round the peninsula by the railway, halting at Vannes, Plouharnel, Lorient (whence I visited the Ile de Groix), Quimperlé, Quimper, Brest, Morlaix; but my remarks will be confined mainly

to the sections of the Ile de Groix, Quimperlé, and Morlaix. The physiography of all this part of Brittany singularly resembles that of Cornwall and the adjacent districts of Devon. There are the same wide and gently undulating plateaux and low rolling hills, the same tracts of grey granite and of shivery slate, the same steep-sided valleys, which at last are occupied by the sea, and sometimes become veritable fjords studded with hummocky islands: there are the same bare far-reaching moors covered with gorse and ling and heath: nay, even in the minor features, due to the hand of man, the likeness continues, in the dolmens and menhirs of olden times, in the cottages and the dykes of earth and stone that replace hedges among the fields—even in the irregular twists and turns of the lanes!

Brittany, where I saw it, is a rather difficult country for the geologist. Except on the granite moors and on the sea-coast, and occasionally in the valleys, natural sections are rather rare, and the most favourable localities, as it happens, are often far away from the only convenient halting-places. As the country is not densely peopled, artificial sections are not very common. Hence one may often walk a considerable distance without seeing any thing but woodland or cultivated fields. The task, then, of the geological surveyors must have been a laborious one, and I beg leave to express my admiration of the manner in which it has been accomplished*.

(1) *The Ile de Groix.*

The admirable memoir by Dr. C. Barrois† on this out-of-the-way locality makes it needless for me to describe in detail its geology. I will merely record the impressions which I formed during my examination of the eastern half of its coast. This is generally rocky, occasionally precipitous, but, as a rule, easily examined. The dominant rock is a mica-schist; that of the greatest mineralogical interest is the *amphibolite à glaucophane* described by Dr. Barrois. Of the former there are several varieties. The commonest contains chloritoid as a constituent; garnets are frequently present. Besides this there are some felspathic, staurolitic, and graphitic schists. These *schistes à chloritoïde* are generally full of a well-developed silvery mica (paragonite?), and the red garnets commonly vary from the size of a pin's head to that of a small pea. The structure and composition of the group has been so fully worked out by Dr. Barrois, that I content myself with referring to his paper. I will merely add

* The circular of invitation, issued by the Société Géologique de France, contains a very complete list of works dealing with the geology of Brittany. As this is a long one, and as a copy is preserved in the library of the Geological Society, I have thought it needless to add a bibliographical section to this paper. As the questions mentioned above are in most cases comparatively modern, I have not deemed it necessary to examine the older works, and to some in the list I have not access, but I have freely consulted the various papers by Dr. C. Barrois, Mr. Whitman Cross, and Dr. Le Hir, which deal with the districts visited by myself, and I took with me the sheets "Lorient" and "Chateaulin" of the French geological map. Those including the remainder of Brittany are not, I believe, as yet published.

† Ann. de la Soc. Géol. du Nord, t. xi. p. 18.

that the group, as a whole, not seldom reminded me in its mineral composition and structure of some of the schists, rich in silvery mica and garnet, which in the Alps, so far as my knowledge goes, appear to occupy a rather definite horizon, some little distance below the base of the great and widespread uppermost group of schists (the *schistes lustrées* in part of some authors; *bündner Schiefer* in part of others, the *graue Schiefer* and *grüne Schiefer* of the Swiss survey map).

Whatever may be the earlier history of these chloritoid-schists, they bear the impress of some later and very potent earth-movements. These have produced the dominant foliation, which sometimes renders the rock almost fissile, and in the planes of this cleavage-foliation, so far as I could ascertain, the larger scales of chloritoid (sometimes $\frac{1}{3}$ inch diameter) have been developed. In the bay, south of Locmaria, about the middle of the south side of the island, the dip (about 20°) of the cleavage-foliation is slightly to the east of south, but afterwards it becomes roughly south-west; and this appears (allowing for local disturbances) to be the prevalent direction in the eastern part of the island, the angle of inclination being commonly from 15° to 20° .

The amphibolites are chiefly developed to the south of Locmaria, and near the Fort de la Croix at the eastern end of the island. They occur in bands, apparently interstratified with the other schists, at most about 50 yards thick, but often less.

Besides glaucophane, which is usually present, they contain garnets (commonly abundantly), together with epidote, green hornblende, white mica, quartz, sphene, rutile, and hematite. They are commonly schistose in structure, and occasionally exhibit mineral banding, both structures coinciding with the "cleavage-foliation" in the chloritoid-schists. The banding is often produced by a predominance of epidote, sometimes of glaucophane. Occasionally, as in a case south of Locmaria, the amphibolites are rather massive. Sometimes, as to the north of the Fort de la Croix (where the rock is coarser, the garnets being as large as a pea), they are conspicuously schistose. Not seldom the amphibolites are rotten, and I believe that any one who wished to collect the rock simply for microscopic sections would obtain the most suitable specimens from the rolled pebbles on the beach. The schistose structure is not always clearly marked, and some of the rock in its mode of decomposition reminded me of the more massive varieties of the "chloritic schists" of South Devon*. The constituent minerals have been so admirably described by Dr. Barrois in the memoir already quoted, that I will merely say that some of the varieties of the rock are extraordinarily rich in glaucophane, though the individual crystals of the mineral are not generally large †. I quite agree with Dr. Barrois that the crystallization of the glaucophane is posterior to the pressure which has in

* Quart. Journ. Geol. Soc. vol. xl. p. 1.

† Some of the less schistose forms curiously resemble, both macroscopically and microscopically, the glaucophane eclogite which I have described from the Val d'Aoste (Mineral. Mag. vol. vii. p. 1).

all probability produced the foliation of the rock, for the crystals exhibit no sign of strain or fracture, but that the garnets existed anterior to the crushing. These are of a brown-red colour, of variable size, but seldom, if ever, more than 0''·4 diameter, commonly less, often about 0''·1.

The genesis of these glaucophane-amphibolites is a question of great interest, to which I directed special attention. The rock certainly appears interstratified with the other schists; it is distinctly foliated, sometimes banded, and simulates stratification. But I agree with Dr. Barrois that we cannot, therefore, claim for it a sedimentary origin*. There appears to be little indication of a graduated passage from the one rock to the other. As a rule the divisional lines are rather sharp. Once or twice I noticed thin bands of mica-schist in the amphibolite, which were difficult to explain on the theory that the latter was intrusive. Still, as both rocks have evidently been subjected to earth-movements of great intensity, which have given rise to the structures now dominant, it is possible that the ordinary minor indications of intrusion may have been effaced, and small included masses of the schist may have been flattened out by the same cause which has produced the simulated stratification of the amphibolite. So that while I will not speak positively on a question in regard to which Dr. Barrois, with his much greater experience, fears to commit himself, I must say that I incline to regard these amphibolites as rocks of igneous origin and intrusive, but converted into schists by pressure and recrystallization. The occasional "puckering" of the foliation looks as if some movements had occurred after the present crystallization had taken place. As to the condition of the schist when the amphibolite was intruded I found no evidence, except that I noticed here and there near the junction some rather lenticular bands which contained some large, but ill-preserved, crystals, apparently of staurolite or andalusite.

(2) *The District around Quimperlé.*

In this district I examined a part of the sea-coast near the embouchure of the river Pouldu, a spot about seven and a half miles to the south of Quimperlé, and carried on my work from that town in a north-westerly direction for about three miles along the Bannalec road †.

The town of Quimperlé is built on the rough slopes of two glens,

* Dr. Barrois suggests a similar explanation for the banded structure of the hornblende-schists at the Lizard. It is possible that he may be right. That foliated schists can be so formed has been shown by Mr. Teall, and is proved elsewhere in Brittany, as will be seen. At the same time I did not myself see in the Ile de Groix nearly such good imitations (if I may use the phrase) of the phenomena of bedding as there are at the Lizard. Moreover, the amphibolites are comparatively thin bands, often only a few yards thick, and this structure is most conspicuous in their outer part, while the hornblende-schists of the Lizard are very thick.

† It would be difficult to find a more picturesque place than Quimperlé, or a hotel more pleasantly situated or more comfortable than the Hôtel de France et d'Angleterre, where I spent five days.

which unite their waters at the lower end of the town. The dominant rock, for about half a league to the north and rather more than double that distance to the south, is a strong gneiss (*mica-schiste granitique* of Barrois), a broad zone of which extends across the country in a general W.N.W. direction. The commonest variety may be described as a moderately coarse, rather felspathic gneiss, consisting of quartz, reddish felspar, and dark green mica, the last-named mineral occurring in thin irregular bands, with a generally parallel arrangement, so as to produce a somewhat foliated structure, though the rock is not markedly fissile in this direction. Macroscopically the rock recalls to mind some of the Hebridean gneisses of Scotland, and of the Laurentian gneisses of Canada. Varieties may be noticed. A quarry near the river and the viaduct, just below the town, affords a good exposure of the commonest type. Higher up, just beyond the last house, we find a more micaceous variety, while, still higher up, just within the town, a quarry shows a rock with but little mica, more resembling a fine-grained vein-granite. Microscopic examination of the first-named rock shows it to be composed of quartz, felspar (orthoclase and plagioclase) a little decomposed, and a dark olive-brown mica. The wavy outlines of the felspar, the way in which it encloses rounded grains of quartz, and the general association of the two minerals and of the mica, recall to mind a structure which, whatever be its significance, characterizes, so far as I know, the Laurentian gneisses.

The finer-grained rock mentioned above (quarry inside the town) differs, under the microscope, from an ordinary vein-granite, and exhibits the same arrangement of the quartz and felspar which characterizes the gneiss just described. The only variations are that all the constituents are slightly smaller in size, there is less mica, less approach to a foliated structure, and perhaps a slightly greater proportion of quartz to felspar.

These rocks, then, like many of the older gneisses, give us no dominant indication of cleavage-foliation, and we may venture, I think, to say that, whatever be their genetic history, they belong to the Laurentian gneisses, though they may subsequently have undergone some modification. Foliation at the first quarry strikes a little to the east of N.N.E.; the dip is towards the western side, and is low, not exceeding 15° . This structure, however, may be, in the main, a record of a later disturbance.

Following the road to Bannalec in a general north-west direction we pass at first outcrops of the above-named gneiss. Then we find a quarry in a fairly well-preserved felspathic granite with two micas, the black predominating, and about a furlong beyond we pass a vein of rotten felspathic granite, intrusive in a micaceous gneiss, the foliation of which I should regard as mainly the result of cleavage, and as prior to the intrusion of the granite. At a distance of about 2.4 kilometres from the town is a quarry in a rotten, rather fine-grained felspathic granite (the *granulite* of Barrois); then comes a schistose felspathic gneiss (*granulite schisteuse* of Barrois); the foliation in the latter appears to me due to mechanical causes. The strike in a

pit about $5\frac{1}{2}$ kilometres from the town is very slightly west of north. Under the microscope the foliated structure is distinctly indicated by wavy bands running across the slide, like rootlets growing in the direction of the lines of foliation. These are occupied by a mixture of white mica, often microlithic, tiny scales of brown mica (occasionally), an earthy-looking mineral, and chalcedonic quartz. Between these bands occur fragments of felspar, an irregular mosaic of quartz and felspar, and larger scales of mica. Among the felspar fragments, which are sometimes a good deal decomposed, orthoclase can, I think, be recognized, also microcline, and a little plagioclase with lamellar twinning. In the most decomposed felspar tiny scales of white mica have often formed. It is rare to find a quartz grain so much as 0.02 inch in diameter, but lenticular aggregates composed of irregularly outlined and often flattened-looking granules, just like the structure in a mica-schist, are frequent; sometimes the majority of the granules in one of these aggregates show the same tint. The brown mica also often occurs in aggregated flakes, and I am inclined to refer some associated white mica enclosing black flakes to an alteration of biotite. It is to my mind obvious that we have here a case of the formation of a gneissoid rock from a fairly coarse granitoid rock by crushing, followed by a certain amount of mineral rearrangement—*i. e.*, a case of cleavage-foliation. My impression in the field, and it is not contradicted by microscopic examination, was that this gneissic rock had been developed from the granite already described.

About one kilometre further is a large pit in a very different rock, the *hällflinte* of Barrois. Two varieties of it occur here—the one, black, compact, with sharp subconchoidal fracture, behaving under the hammer almost like flint; the other slightly schistose and streaky, rather grey in colour, and exhibiting an “augen-structure” on a small scale. Under the hammer the latter is more fissile, and does not fly into such sharp-edged chips. The banding is about vertical, striking between E.N.E. and E. Both rocks weather a pale grey colour, and are much jointed. In the time at my disposal I could not find any distinct line of junction between the two varieties, but in the pit the grey rock certainly occurs on both sides of the black. On microscopical examination the grey rock proves, as I had already suspected, to be a rhyolite, in which subsequent pressure has produced a slight schistosity. We can still recognize the remains of a flow-structure; the “eyes” are porphyritic crystals of felspar; sometimes they are almost crushed, sometimes they have been sheared, and the one fragment pushed in advance and slightly separated from the other. One crystal, now about .15 inch long, has had its ends crushed, and the other part split and sheared, so that the pieces rest one on the other like a series of slabs placed on the slope. The rock does not appear to have formerly contained any large quartz-grains, but two or three flakes of white mica resemble an original constituent. The crushing appears to have acted nearly at right angles to the actual flow-structure. It has developed, as usual, a minute filmy golden-coloured mineral (seri-

cite?), arranged in slightly wavy bands, which give the brightest colours when placed at about $\pm 5^\circ$ with the vibration-planes of the crossed nicols. There are some specks of iron oxide, and one grain may be brown tourmaline. Of the nature of the black rock it is difficult to be sure. There is, as is common with hard, compact, flinty rocks, a want of definiteness in its structure. It might be a glassy igneous rock, modified by decomposition and other mineral changes, but then we should have expected that it too would have shown a schistose structure. The absence of this suggests a difference in origin. On careful examination I fancy I detect faint indications of fragments, so that I believe this to have been (like so many of these *hällflintas*) a fine-grained tuff.

On one point I feel certain, namely, that these two rocks have no relation to the gneissic series*. The alteration in them is not more than we often find in the lower Palæozoic rocks of Britain. They may be nearly paralleled by specimens from Charnwood or from Carnarvonshire. They may possibly be rather older than our Cambrian, but they might be later than this formation.

Beyond this pit occurs a felspathic gneiss with cleavage-foliation like that already described.

To the south of Quimperlé the coarse, strong gneiss continues for some distance, and is followed by "*granite mica-schisteux*;" then comes a zone, some couple of miles wide, occupied by "*mica-schistes*," regarded by Dr. Barrois as generally equivalent to the *schistes à chloritoïde* of the Ile de Groix. Little rock is seen by the roadside till the coast is approached. I only noticed a very fissile mica-schist (about $9\frac{1}{4}$ kilometres from Quimperlé), which much resembles some of the Alpine mica-schists, in which crushing has produced a cleavage-foliation, obliterating all earlier structures. The strike of the cleavage-foliation is roughly east to west, and the dip very high to the north. But on reaching the coast a very interesting series of sections is obtained at low tide, just within the embouchure of the Pouldu, and along the sea-coast to the west.

The low cliffs in the eastern part of this section afford us repeated sections of a very definitely banded gneissoid rock, with some amphibolites and a vein of felspathic granite. The first-named rock consists of bands of a rather fine-grained gneiss, composed chiefly of quartz and felspar, with a small quantity of a silvery mica of a yellowish-grey colour, alternating with a rather darker and coarser-grained rock; the one somewhat resembling a vein granite, the other a felspathic gneiss. The bands of the former rock vary generally from $\frac{1}{4}$ " to 2" thick; those of the latter are sometimes only about $\frac{1}{4}$ " thick, but are usually more, and generally dominate over the other. Both rocks, but especially the former, have a "slabby" fracture parallel with the mineral banding; in the latter, however,

* I speak, of course, of this particular *hällflinta*. The *hällflinta* or *petrosilex* of the "Promenade" at Quimper appeared to me a result of crushing of the granitoid rock which forms the hill, and a slide which I have had cut from a specimen taken by Mr. Hill seems to me to accord best with this view; at any rate it indicates intense crushing.

the felspar often occurs in rounded grains up to the size of hemp-seed, with a greenish-grey mica between. Still it is difficult to explain the marked mineral banding of the rock, evidenced among other things by the solidity of the paler, and the incoherency of the darker bands,—exhibited both in their weathering and their behaviour when hammered, the latter rock crumbling to pieces like an arkose,—unless we assume that it existed prior to the crushing, and of this I think we obtain, at least at one point, conclusive evidence. As a rule the crush-planes and apparent stratification-planes are parallel, both striking roughly east to west, with a dip of about 45° to the northern side; but at one place we have a section, of which a rough sketch is annexed (fig. 1). Here we have the mineral banding perfectly well

Fig. 1.—*Diagrammatic sketch of Contorted Banded Gneiss at the Embouchure of the Pouldu. (About 6 feet high.)*



The lines indicate the courses of the more conspicuous quartz-felspar bands; the interspaces the more micaceous parts, which have a rude cleavage parallel with the arrow.

Fig. 1 A.—*Small portion of one of the Contortions shown in Fig. 1, about 8 inches in diameter, showing the quartz-felspar bands with occasional cracks parallel with cleavage, the dotted part being the more cleaved micaceous bands.*

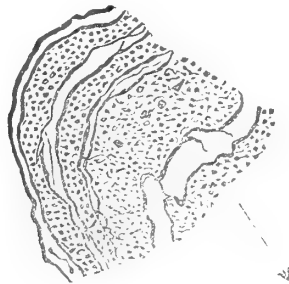

defined, and forming a series of loops, the axes of which are parallel with the usual direction of the banding and cleavage-planes, but at the top and bottom of the loops the bands “wriggle” across the direction of cleavage. Throughout the darker bands the cleavage

runs roughly parallel with the axes of the loops, but where they make with it the largest angle it is least definite, and here transverse cracks, apparently giving relief from strain, traverse the lighter bands.

I have examined slices cut from four varieties of this series, two of them representing the above-described varieties taken at the "wriggle," the third, a slab rather intermediate between the two varieties, and the fourth a coarser kind which exhibits very distinct banding, zones of mica alternating with felspathic layers, from a quarter to half an inch or more wide.

The principal minerals in the first rock are felspar, quartz, mica, iron oxide, and an earthy-looking substance which, for brevity, I will call ferrite. The first two are by far the most abundant, and the felspar rather exceeds the quartz. The felspar appears to be orthoclase; at any rate, the lamellar twinning, usually characteristic of plagioclase, is absent. The felspar occurs in rather elongated grains of irregular outline (Pl. XVII. fig. 1); many of these show a cleavage roughly perpendicular to the longer axis of the grain. The larger grains are much interrupted by inclusions of quartz, usually very clear. The form of these varies much: sometimes they are rounded or oval spots, occasionally one or more of the boundaries is rectilinear, and they sometimes tend to be arranged in ill-defined streams in the direction of the longer axes of the felspar; thus at first sight parts of the slide might be taken for a kind of mosaic of rather small independent grains of quartz and felspar, but on applying the nicols the uniformity of tint indicates the not unfrequent presence of a single crystal of felspar interrupted by the quartz grains. There are also some elongated streaks of quartz formed of a few long interlocking grains which show strain-shadows. The quartz, too, tends to parallelism in the direction of its grains, and, speaking of the slide as a whole, the minerals exhibit a rather general uniformity of tint, as if this arrangement held throughout in the individual constituents. The mica, of which there is very little, is sometimes brown, sometimes olive-grey; irregular wavy cracks, marked out by ferrite, traverse the slide roughly in the direction already mentioned. The minerals in the second slide are the same, except that there is less quartz and a good deal of an olive-grey mica, in flakes often about $\cdot 03$ inch long. There are also some smaller flakes of brown mica. As in the last slide, the felspar grains are interrupted by secondary quartz. Cracks, indicated by ferrite, traverse the slide, giving parts of it almost the aspect of a true fragmental rock. The third slide contains similar minerals, the mica occurring in fairly thick and well-defined bands. In the fourth the arrangement is similar, but the quantity of mica in different parts of the slide is variable, and in parts there is marked evidence of crushing.

The mica described above is of a pale olive-grey colour, sometimes almost colourless, often streaked with darker lines and with plates (hæmatite?) between the cleavage-planes. It is slightly dichroic, and, notwithstanding its paleness, I am disposed to regard it as an

altered biotite*, which mineral in an unaltered condition may be occasionally detected.

Just within the embouchure a very singular rock occurs, associated with the ordinary gneiss, and overlying a band of amphibolite. It is very fissile, and appears to consist of flattened lumps, seemingly of white felspar, spotted with quartz, in a grey schistose micaceous matrix. The junction with the overlying gneiss is slightly irregular, and the bed seems rather variable in thickness. On examination with the microscope I find its relations with the gneiss to be closer than I had anticipated in the field. The matrix consists of a mica similar to that in the gneiss, alternating with thin bands of quartz. Both have evidently undergone much disturbance. Some quartz, which is minute and chalcedonic, is certainly of secondary origin; but the larger grains appear to belong, like the larger mica flakes, to an earlier stage in the history of the rock, as though it had been broken up and recemented. The "lumps" exhibit the same compound structure as has been already described in the felspar of the gneiss, but the quartz inclusions are more numerous and the felspar is less characteristic. In one grain these lines of inclusions appear to be bent into a series of arches, the points of which lie in a line roughly parallel with the foliation. Another grain appears to have been broken up and recemented.

These rocks, then, afford unequivocal indications of mechanical disturbance, undergone after they had assumed a crystalline condition, and followed by some amount of mineral rearrangement. There are also marked indications of mineral rearrangement on a larger scale, and it is an interesting question how far that is anterior or posterior to the crushing. As the bands of mica and, to some extent, the inclusions of quartz are parallel with the lines of cleavage, it might be urged that these also had indirectly resulted from the same cause. But to my eye the bulk of the mica has every appearance of being an original constituent. It is sometimes twisted, pushed, and tumbled about, or the ends of the flakes have a "pinched-up" look; the lines of fracture often cut completely through the felspar-crystals with their quartz-inclusions†, and the fragments are occasionally separated and displaced (Pl. XVII. fig. 2). Hence, though I should admit that a certain amount of mineral deposition and recrystallization, especially in regard to the quartz, has occurred since the crushing, I believe that when this happened the rock was already foliated. Indeed, apart from microscopic examination, I could not otherwise explain the discordance of the mineral banding and the cleavage already described. We have, then, here another case of a cleavage-foliation impressed upon a rock already foliated. What is the history of this earlier foliation our present knowledge does not

* The "bleaching" being due to the concentration of iron oxide in the cleavage-planes. Cf. the changes which have been described in hypersthene and olivine. Hence the mica has been changed from a magnesia-potash-iron mica to a magnesia-potash mica (perhaps hydrous).

† The uniform tint of these inclusions suggests that they are secondary and what is often called *quartz de corrosion*; but, as stated, I cannot regard these as posterior to the crushing.

enable us to say. I will only remark that it is difficult to explain this marked mineral banding without assuming some original differences of arrangement in the constituents of the primary rock.

These gneissose rocks form the irregular coast-line to the sandy bay of Kersélec, but we find an interesting variation before reaching a headland occupied by an old fort. Here is a band of mica-schist, perhaps 40 feet thick; it distinctly underlies the banded series already described, and overlies a less banded series resembling a coarser part of the upper rock, but rather greener in colour. A similar rock may be seen at the top of the cliffs near a signal-station, and by the fort just beyond is a darkish green gneissic rock*. The mica-schist has a general resemblance to that at the Start Point (S. Devon), and has obviously undergone cleavage-foliation. This, however, is parallel with the bedding of the rock †. In the sandy bay above mentioned we have more or less banded gneissic rock resembling that which is already described.

Bands of "amphibolite" occur at intervals along the coast. These, according to the French map, are three in number, and two of them are marked as extending from the embouchure of the river to the sandy bay. Between these is indicated a band of serpentine; this, however, I did not see. The amphibolites appeared to me undoubtedly intrusive rocks; for though they had a general concordance with the mineral banding of the gneiss, I occasionally detected them distinctly cutting across it (fig. 2), and I further

Fig. 2.—*At the Embouchure of the Pouldu.*

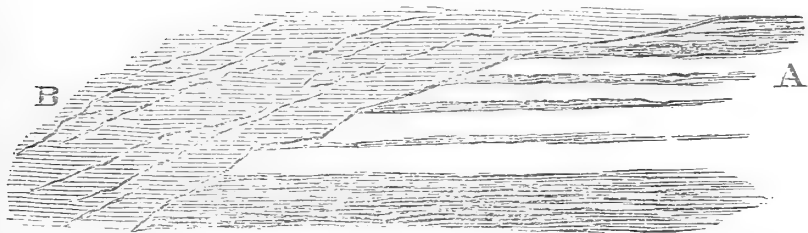

A. Banded gneiss, the darker shades representing the more micaceous layers.

B. Amphibolite, crushed and schistose, but far less regularly banded than A.

believe that the gneiss was already foliated when the intrusion took place, but that the mechanical disturbance which has affected the gneiss has produced distinct schistosity in the amphibolites.

I have examined specimens of two of these amphibolites from the western side of the peninsula, one rather coarse, the other compact

* The former of these, and perhaps also the latter, is very likely a continuation of the beds mentioned on the shore, but I had not time to prove this.

† Owing to the fissile character of the rock it is practically impossible to obtain a sufficiently thin section for accurate microscopic examination. Parts of it are almost opaque from the abundance of a black mineral, which, as in the specimens from the Start, is probably partly graphite, partly iron oxide; there is a white mica, and some brown, and a fair amount of a dichroic greenish mineral, rather like the chloritoid of the Ile de Groix.

and very distinctly schistose. The principal minerals in the former are hornblende, chlorite, epidote, felspar, quartz, sphene (?), and probably hæmatite. The rock has a somewhat foliated structure, the bulk of the first three minerals being associated in rough wavy lines, inosculating to form a rude network, and the interspaces being occupied by felspar- or quartz-grains, across which are "trailed" small insulated crystals of hornblende, epidote, or chlorite. No polysynthetic twinning is exhibited by the supposed felspar, and it is exceedingly difficult to distinguish some of it from quartz. The constituents of the more compact rock appear to be the same, but they are much smaller in size, though the hornblende-crystals are sometimes larger than the rest. This mineral is not of so deep a green as in the other rock. I suspect, though I have not been able to prove it, that a light-coloured variety of augite is also present. A rough parallelism of the constituent minerals, without much tendency to banding, is very conspicuous. From the slide alone one would have identified the rock as a hornblende-schist without hesitation. In these specimens molecular rearrangements appear to have entirely obliterated the lines of cleavage, which have remained so conspicuous in the associated rocks*.

Though I twice visited this locality, I was not able to carry my examination further than the Bay of Kersélec, and then could only examine the headland forming its eastern boundary from the top of the cliffs, their base being washed by the sea. Its western boundary, however, according to the French map, repeats the sections which I have already described.

A section on the Belon river to the south-west of Quimperlé is of so much interest that, although at some distance from the line described above, I will briefly notice it. The new road, descending to a ferry, passes over a coarse gneissoid granite, which is well exposed on the shore below. Above the ferry-house is a fine-grained mica-schist, dark grey in colour, with a marked foliation, striking slightly south of west, nearly vertical, but perhaps dipping on the northern side. Just below the ferry-house are several small vein-like intrusions of fairly coarse granite, and further down the estuary we reach the main mass of the granite. The effects of pressure on the intrusive granite are very interesting. The whole has been affected by cleavage-foliation. A vein, comparatively thin, and lying perpendicular to the pressure, has been still further elongated; one transverse to it, or thick in section, has been distorted or zig-zagged (fig. 3). The normal mica-schist or micaceous gneiss consists of quartz, biotite, a white mica (in rather smaller scales), and a granular mineral, probably felspar rather decomposed, with one or two small garnets. It has evidently undergone compression, subse-

* Near the most northern of the amphibolites a dyke of felspathic fine-grained granite (*micro-granulite*, Barrois) cuts right across the strike of it and the banded gneiss. It is much decomposed, contains either two felspars or crystals of a felspar in a felspathic base, no great amount of quartz, and black mica, some in well-developed hexagonal plates. I have not examined it with the microscope. It shows no signs of being crushed. According to the map this dyke occurs at intervals for about a mile along the west bank of the river.

quent to the crystallization of its constituents ; but the indications of crushing are not quite so clearly marked as I had anticipated, some of the biotite having escaped with little change. I should conjecture that the rock was originally a rather fine-grained micaceous gneiss, fairly homogeneous in structure, and that the pressure had been oblique to the original foliation. The results of crushing are far more marked in the granite. It has evidently been a coarse-grained rock, composed of quartz, felspar, and mica. Parts of the slide show where the rock has been utterly crushed, and consist of a sort of mosaic of quartz, decomposed felspar, and mica. In other parts large fragments of the original felspar crystals still remain. Where

Fig. 3.—*Small intrusions of Coarse Granite in a Micaceous Gneiss, both showing effects of pressure. Near the Ferry House, Belon River. (Size about $6\frac{1}{2}$ by $2\frac{1}{2}$ feet.)*

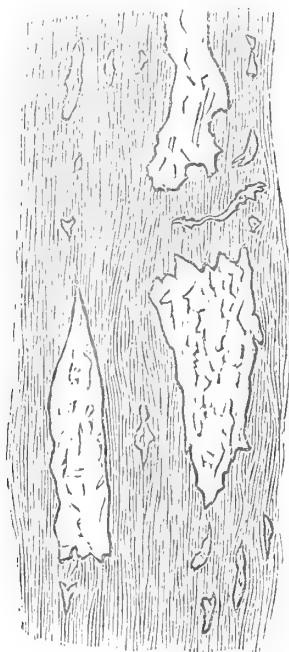

at first sight there appear fair-sized grains of quartz, application of the nicols shows these to be composite in structure, though often one tint predominates in the constituent grains. Recementation, however, is complete ; but the borders (that is, we may presume, the cementing material) are often differently coloured from the grains on either side. The brown mica forms irregular lenticular bands lying in the general direction of the cleavage. It is rare to find a flake $\cdot 02$ inch long. Commonly the bands are made up of aggregated flakes about $\cdot 01$ inch long or less. Here and there is a fair amount of a white mica ; part may be a true secondary product, but some, I think, is only an alteration form of the biotite. I feel convinced that these streaks of biotite owe their origin to a crushing up, perhaps sometimes to a crushing together, of the large flakes which existed in the unaltered granite. I may remark that both in the mica-schist and in the granite reconsolidation appears rather un-

usually complete. A specimen of granite from the hillside, obtained from a cutting, and so unweathered, recalls to mind some of the granitoid rocks associated with the oldest Archæans. I may add that, even in the thin veins, the granite is almost as coarse as in the mass, and yet the adjacent mica-schist shows no appreciable alteration.

(3) *Roscoff and Morlaix District.*

The low cliffs and skerries on the shore on the west side of Roscoff, a quaint little sea-port, some sixteen miles to the north-west of Morlaix, exhibit sections of great interest. The following rocks occur:—(1) Banded gneiss; (2) a moderately coarse-grained porphyritic granite, rather dark in colour; (3) a rather fine-grained and lighter-coloured granite; (4) amphibolite.

(1) This gneiss is a rather fine-grained rock, consisting (macroscopically) of quartz, felspar, and mica, chiefly black. The banding is very distinct, and is brought out in weathering, one set of layers containing more quartz and less mica than the other. Thus the former are paler in colour, of a yellowish or reddish-grey tint; they yield slowly and uniformly, and project in little slabs; the latter are a dull or brownish grey, they crumble away, and develop a fissile structure. The annexed sketch may save a longer description (fig. 4). The more quartzose layers are often rather less than $\frac{1}{2}$ "

Fig. 4.—*At Roscoff.* (Length about 7 feet.)

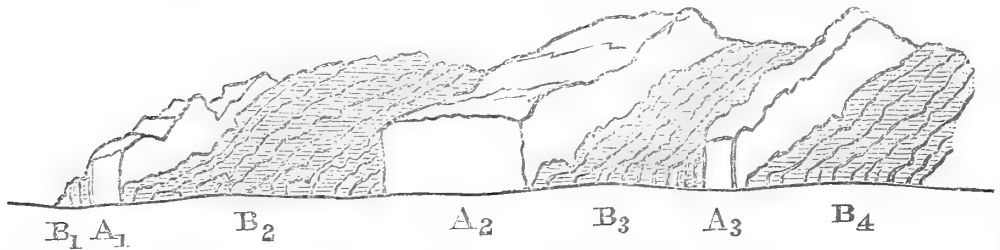

$\left. \begin{array}{l} A_1 \\ A_2 \\ A_3 \end{array} \right\}$	$\left. \begin{array}{l} \text{Quartzo-felspathic bands, with} \\ \text{some mica, slightly foliated.} \end{array} \right\}$	$\left. \begin{array}{l} B_1 \\ B_2 \\ B_3 \\ B_4 \end{array} \right\}$	$\left. \begin{array}{l} \text{More micaceous bands, with much} \\ \text{more appearance of crushing.} \end{array} \right\}$
--	--	---	--

but they are found up to 2" or 3", and occasionally more than 12"; the micaceous layers are thicker, and a micaceous streak not seldom occurs in the thicker quartzose bands. They appear to pass into one another, but the change is rapid. The beds are a good deal twisted, but the general strike appeared to me between W.S.W. and S.W., with a dip of about 60° on the southern side. There are, especially in the micaceous layers, indications of a cleavage-foliation coinciding with the stratification-foliation. One crag, however, beautifully illustrates the independence of these structures. Here a roll has brought the stratification-foliation to make a low angle with the horizon, and the cleavage can be discerned maintaining its normal direction and cutting across it (see fig. 5).

The chief constituents of these rocks are quartz, felspar, and a

dark olive-brown mica, with an occasional crystalline grain of tourmaline and of a mineral which I have not succeeded in identifying*. The quartz and the felspar grains have the subangular or subrotund outlines which seem to be characteristic of the older gneisses, and

Fig. 5.—*At Roscoff.*

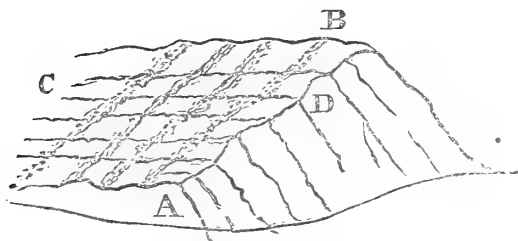

A-B. Lines of mineral banding.
C-D. Lines of slight rude cleavage.

the former are occasionally distinctly elongated, with a slight linear association, and have some appearance of strain-polarization. Among the felspars plagioclastic twinning is seen, but many grains are untwinned. The mica occurs in well-developed flakes, often about .02 inch long or rather less. They have a fair thickness perpendicular to the basal plane, the proportions in the sections being about 1 to 4. They lie roughly parallel with the mineral banding. The crystals are well developed, and do not generally appear compressed or crushed at the edges. In the more micaceous layers there is also a marked diminution in the quartz, and plagioclastic twinning is much more common in the felspar. There is also more of the unidentified mineral. This gneiss appears to be very little affected by the intrusion of the porphyritic granite. A slice cut from a specimen taken from within 4 or 5 inches of a junction does not differ appreciably from apparently normal specimens; and even at a junction where the granite interpenetrates and appears to be fused into the gneiss, the latter in parts of the slide retains its normal character. Yet the granite is fairly coarse and porphyritic to the last, so that the temperature of the surrounding rock must have been high during the solidification of the former. Hence I conclude that the latter had assumed its present mineral condition before the intrusion of the granite. In the case where a faint cleavage is seen crossing the stratification-foliation, both the quartz and the felspar, especially in the larger grains, indicate strains. Many parts of the slide have a peculiar fragmental aspect, not as if there had been absolute crushing, but as though the grains had been separated, slightly displaced, and recemented; indeed, I am almost certain that sometimes two or

* It occurs sometimes in roundish grains, but sometimes in imperfect prisms, angles about 120° being occasionally shown. In texture and faint bluish tint it a little resembles apatite. It seems to have two imperfect cleavages, nearly, if not quite, at right angles. It encloses rarely brown mica, zircon(?), and cavities, and it shows (also rarely) a brown decomposition-product. It is rather feebly doubly refracting, which adds to the difficulty of determination; but I think it is not uniaxial.

three grains have once formed portions of a larger one. The mica-flakes also appear often as if they had been twisted out of their original position, and the bands themselves are sometimes rather rumpled. In short, the microscopic structure of the rock recalls that which I have observed in other gneisses and schists which have been exposed to a pressure not sufficient to develop a marked cleavage-foliation.

(2) The largest mass of the porphyritic granite is near the eastern end of the section examined. The same rock, I believe, forms the numerous skerries and tors east and south-east of the town. This granite cuts both the amphibolite and the gneiss*, being completely welded to, and sometimes including strips of, the latter. As said above, it is coarsely crystalline up to the junction-surface; one would therefore suppose that it cooled slowly. Microscopic examination shows it to consist of quartz, felspar, brown mica (partly altered here and there into a green mineral), and a little apatite and iron oxide. Some of the felspar is orthoclase, which is, in places, much altered, being replaced by minute kaolinitic and micaceous minerals; but plagioclase is more common, showing lamellar and "pericline" twinning. The rock has sometimes a slightly foliated aspect, and under the microscope shows indications of disturbance, though this is less marked than in the gneiss and the amphibolite†.

(3) The fine-grained granite occurs in irregular dykes, cutting right across the banding of the gneiss, and including fragments of the porphyritic granite (fig. 6). In one case, at its junction with

Fig. 6.—At Roscoff.

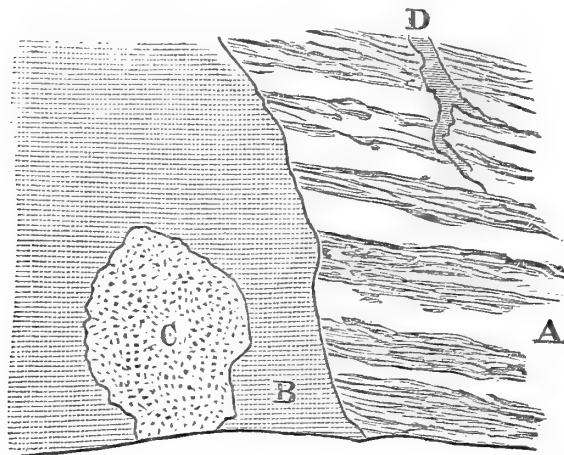

- | | |
|--|---|
| <p>A. Gneiss, banding very distinct; lighter layers, sometimes full $\frac{1}{2}$ inch thick.</p> <p>B. Fine-grained granite.</p> | <p>C. Included fragment of dark porphyritic granite.</p> <p>D. Quartz-felspar vein.</p> |
|--|---|

* In one case it has lifted up and bent into a curve the top bands of the gneiss.

† One or two grains show "corrosion quartz," and in others the lamellar twinning occurs in a part of a grain only, near to a slight bend, which seems favourable to Professor Judd's view of this twinning being sometimes due to subsequent mechanical action.

the gneiss, it is bordered by a quartz-felspar vein, sometimes banded with tourmaline. The "vein" seems to "muddle up" with the granite, but is sharply divided from the gneiss, into which it sends an offshoot. This granite exhibits no signs of mechanical disturbance.

(4) The amphibolite is a dark hornblendic rock, sometimes containing black mica. In some places it seems to be interstratified with the gneissic rock, but as the thickness is variable, and it occasionally cuts obliquely across the bands of the other, I consider it intrusive, though it not seldom follows planes of an earlier foliation. A more or less foliated structure, which is parallel with that dominant in the gneiss, is visible in the different masses; there is no indication of a contact-metamorphism in the latter, and I fully believe that the gneiss was a foliated rock when the "amphibolite" was intruded, but that both were afterwards subjected to considerable pressure. A specimen of the amphibolite, which macroscopically closely resembles the darker more homogeneous varieties of the hornblende-schist at the Lizard, has for its dominant mineral a dark-green hornblende, exhibiting strong dichroism. The cleavages parallel to ∞P are well developed, and crystal faces ∞P and $\infty P'\infty$ are not rare. The grains commonly measure $\cdot 02''$, or a little less, in the direction of the vertical axis, and rather less than $\cdot 01''$ in the direction of the clino-diagonal. A colourless mineral, sometimes slightly "powdered" with ferrite, which has consolidated after the hornblende, comes next. It is difficult to be sure whether this is quartz or felspar, but the latter mineral is present. A little biotite, a few grains of iron oxide, a dirty-looking mineral which I think probably an impure epidote, and some small crystalline grains which I take to be sphene also occur; thus the resemblance of this rock to some of the Lizard hornblende-schists is very striking.

Gneiss and granite, as above described, are traversed by the railway some little distance to the south of Roscoff, and are then succeeded by slaty rock. Morlaix affords excellent opportunities for studying the effects of pressure and of igneous intrusion on ordinary sedimentary rock*. The deep and craggy valley in which this quaint old town nestles by the riverside, the quarries, the roadside cuttings, and even the blocks in the rough-built walls which prop up the terraced gardens, afford endless studies of the results of pressure. The dominant rock formerly consisted of a dark clay closely interbanded with grey silt or fine earthy sand. As a rule the bands of the latter do not now exceed $1''$, and are often thinner. The former are often over $1''$, and sometimes the argillaceous rock is free from the sandy bands. The planes of cleavage and of stratification are very commonly coincident, but the bands indicative of the latter constantly zigzag and wriggle across the former. The sandy bands only exhibit a faint cleavage; hundreds of examples illustrate how they thicken in one part of a crumple and attenuate in another under the alternating action of thrusts and strains. Cleavage is highly developed in the dark bands; its surface-planes are often

* Dr. Le Hir (Bull. Soc. Géol. Fr. 2^e sér. t. xxviii. p. 87) considers the rock about Morlaix to be of Devonian age.

satiny, and frequently rumpled or wavy. A minute filmy mica (sericite?) has been developed, with rutile &c.; but every change is micromineralogical, not greater than may be seen in the Palæozoic rocks of Wales or of S.W. England, in the Jurassic or Carboniferous slates of the Alps, or in the Cambrian of the Ardennes. The rock, at most, can be called a phyllite; it is perfectly distinct from one of the true crystalline schists already described. Still it is both interesting and instructive to observe how close are the superficial structural resemblances of these banded slaty rocks and some of the banded crystalline schists. Rocks might be found at Morlaix which in a photograph (but only in a photograph) would be undistinguishable from some of the banded and, presumably, less ancient schists of the Alps or other similar regions. In one quarry on the Huelgoat road (near the town) I obtained an excellent example of a second cleavage, formed by a crumpling of the ordinary cleavage-layers, which here very probably agree with the stratification—a true “*Ausweichungscleavage*.”

The effects of contact metamorphism are also beautifully exhibited in many places. Sometimes, however, it is surprisingly slight. A dyke of felsite north of the town* barely indurates and does not bleach the dark slaty rock adherent to it; in another place, east of the town, we find a vein of moderately coarse granite converting a dull grey slate into a greenish-coloured “porcellanite.” About Chapel du Mur, chialstolite and a minute black mica are developed; and in one place I found, in a black “phyllite,” crystals of chialstolite full .2" wide and an inch or more long†. The Huelgoat road also affords some excellent illustrations of contact-metamorphism, which I have examined with the microscope. They lead, however, into more than one interesting, but rather wide-reaching question, so that I think it better on the present occasion to content myself with this brief notice, and to recur to them in a future communication. Suffice it to say that the mineral changes in the most highly altered among them resemble those which have been described in the Skiddaw slates near the granite of Sinen Gill, and that these results of contact-metamorphism differ greatly from the gneisses and schists commonly considered of Archæan age, and such as are described in this paper, though possibly they may furnish us with some valuable suggestions as to the genesis of the latter.

Conclusion.

My work in Brittany, of which I have now described the more complete portions, leads me to the following conclusions:—

(1) That the great central folded trough of Lower Palæozoic

* The dyke is about 4 feet thick. In the field, I took it for a microgranulite, but the part in contact with the slate appears, under the microscope, to have been, if not glassy, not more than cryptocrystalline. The junction and some included fragments of the slate prove that to have been cleaved and to have become a “phyllite” prior to the intrusion.

† I failed to find good sections, and chiefly examined loose blocks, so cannot say how near these were to intrusive rock. These rocks had a general resemblance to the altered rocks of Skiddaw.

rocks is bounded on the north and south, and is probably underlain continuously, by gneisses and schists.

(2) Both the Palæozoic and the older series have been pierced by various igneous rocks, of more than one geological age, some being even later than the last great earth-movements.

(3) The intrusive igneous rocks have in some cases greatly altered the Palæozoic rocks, but appear to have produced little effect upon the gneisses and schists.

(4) The action of contact-metamorphism on the Palæozoic sediments does not produce rocks which resemble the presumably Archæan gneisses and schists.

(5) The action of pressure-metamorphism on Palæozoic sediments has in no case produced a rock which is liable to be confounded with the gneisses and schists of Archæan type*.

(6) Although in certain cases igneous rocks have been, in consequence of these mechanical actions, converted into gneisses or schists, yet many of the gneisses and schists evidently were true foliated rocks anterior to the above earth-movements, and the latter rocks exhibit structures very analogous to those of stratification. At any rate, even if they be only igneous rocks modified, this modification was most probably anterior to the commencement of the Palæozoic age.

Further, the close mimicry of stratification indicated by repeated mineral banding in the gneissic series, not in rare and solitary spots, but over considerable areas and in widely separated districts, makes it difficult to understand how this can be explained by any rolling-out of a complication of veins of igneous rocks rather diverse in composition. The absence, from the best-preserved among these, of structures which are known to be characteristic of igneous rocks, or are indicative of crushing, and the presence of structures definite in kind, whatever be their significance, suggests that either the metamorphism from which the present condition of the rock resulted must be carried back to a very remote past, presumably before Palæozoic times began, or there must be some unknown peculiarity in the genetic history of the rocks themselves.

(7) Hence, making every allowance for the various effects of the above disturbances, there is to be found in Brittany, as maintained by Dr. Barrois and other French geologists, a great fundamental mass of true Archæan rock, that is, of rock which, whatever be its genetic history, had become what we should call gneiss and schist before the earliest Cambrian rocks were deposited †.

* It is true I did not see the lowest group in the Brittany Cambrians, the *Schistes de St. Lo*, but Mr. Hill's description of the section of the Lower Cambrians at Crozon (on the sea-coast, south side of the inlet near Brest) was so clear that I deemed it needless to spend a day in visiting it. The rock at Brest is a rather micaceous gneiss, of very ancient aspect.

† *Note*, June 6, 1887.—After this paper had been read, I received a copy of a note on the French excursion to Brittany by Professor de Lapparent (*Rev. Scient.* 1887, p. 38). He concludes his description with this distinct expression of opinion:—"La Bretagne démontre-t-elle, d'une manière indiscutable, l'existence d'un terrain normal de gneiss et des schistes cristallins, antérieur à la série sédimentaire. Ce terrain est remarquable par la persistance de sa com-

Two other points of yet wider interest claim our special attention. One is the remarkable lithological similarity between many of the above-described rocks and those which in other areas are, with more or less certainty, identified as Archæan. The banded gneiss of the Pouldu and of Roscoff, especially the latter, constantly reminded me of the more typical members of the "granulitic" series at the Lizard. Both also, but especially the former (where the results of pressure are more marked), sometimes recalled some members of the "newer gneiss" of the Highlands, especially those which occur some distance away from the northern outcrop. Both, again, often reminded me of some of the finer-grained rocks among the indubitable Hebrideans of Gairloch and the Laurentians of Canada. In some parts of Brittany (as at Quimperlé) I was also reminded of the coarser gneisses in the last-named country, of the coarser Hebrideans of Scotland, and of rocks which, in the Alps and elsewhere in Europe, are believed to be their representatives. Sometimes, moreover, I observed mica-schists, which might be matched in the Alps, in Scotland, and other European localities. Dr. Barrois and other French geologists consider these Breton rocks to be Archæan, and I cannot doubt that they are right. It may be wiser to abstain at present from speculation as to the significance of these coincidences, but at any rate they are facts which must have some meaning, and which it would be unphilosophical to ignore.

The other point is the close geological resemblance between Brittany and the south-west of England. In each district we have a mass of Palæozoic sediments, up to the Carboniferous, resting on a floor of Archæan rocks. Each district has been affected by great earth-movements, of which the most clearly marked in either, at the present time, seems to have closed the Carboniferous epoch of sedimentation. Each, omitting minor flexures, forms a broad synclinal; between these was an anticlinal, now occupied by the sea, from which only a few fragments of the basal rock-masses project. To the north of the English districts is another anticlinal, occupied by the Bristol Channel, followed by the synclinal of the South-Wales Coalfields. Hence, towards the end of the Palæozoic period, a great Highland mass must have existed in this Franco-British region, which, even if we leave out of consideration the South-Wales area, was not less than 300 miles wide across the general strike of the folds. To its altitude we have no clue, but its breadth must have exceeded that of the Alps*, and probably it extended westward beyond the south-western angle of Ireland, while traces of it can be followed

position, en quelque lieu du globe qu'on l'observe. Ce n'est que par une extension tout à fait abusive de l'idée du métamorphisme qu'on a pu penser parfois à supprimer les schistes cristallins de la série chronologique, pour n'y voir qu'une modification capable d'affecter des sédiments d'âge quelconque. Pour tout esprit non prévenu, les fait observés en Bretagne nous semblent de nature à donner le coup de grâce à cette manière de voir."

* The breadth of the folds, and the not unfrequent absence from considerable parts of the district of a marked cleavage-foliation at a high angle, suggests that the vertical elevation of the chain may have been less, comparatively speaking, than in the Alps.

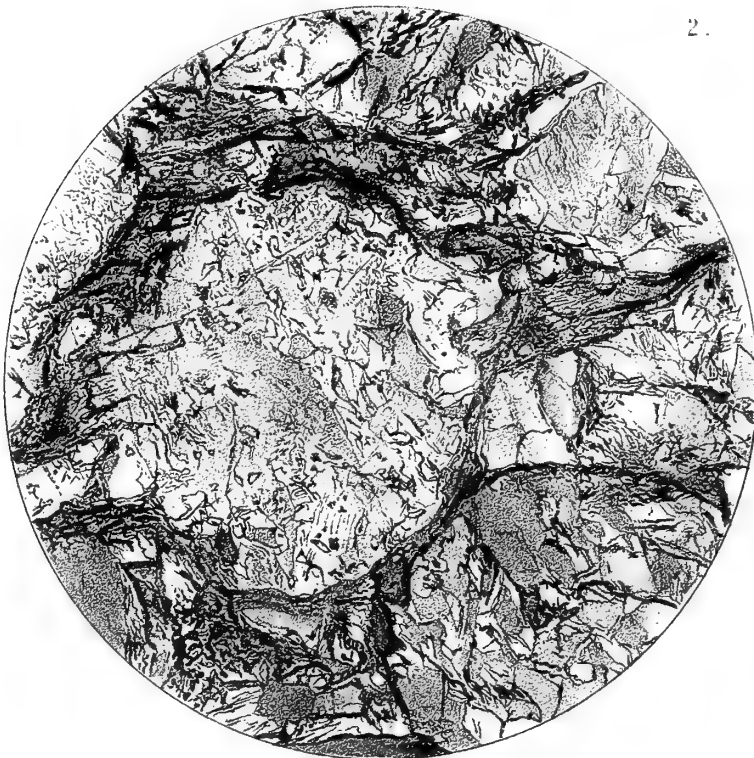
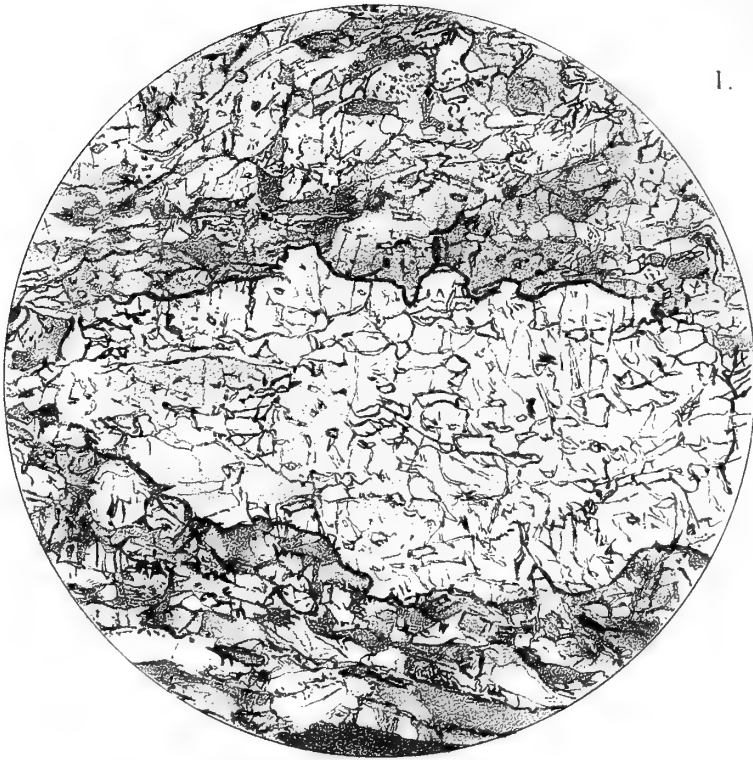

eastwards to beyond the Rhine, more than 35° of longitude. Yet the sea now flows where some of its highest summits may have risen; its only record is preserved in the low plateaux and comparatively humble hills of Cornwall and Devon, of the Channel Islands, and of Brittany. Millions of cubic yards of rock must have been removed by denudation, which must have helped to form the conglomerates, sandstones, and clays of the Secondary and Tertiary deposits of Southern England and North-western France. Like the Alps, this great mountain *massif* consisted of a foundation of presumably Archæan crystalline rocks, which, after undergoing extensive denudation during a long interval of time, was affected by a downward bending of the earth's crust, and received great accumulations of sediment, obtained, no doubt, by the destruction of more remote portions of the ancient land-surfaces*, and then the whole, by new earth-movements, probably in new directions, was again upheaved; the fundamental crystalline rocks, both igneous and "metamorphic," were folded and, in places, crushed so as to assume a cleavage-foliation, while the softer and newer sedimentaries were more markedly plicated, were often cleaved, and in some places underwent other modifications from intense pressure. But in the Alps, although there appears to have been a precarboniferous movement of some importance, the great downward bending did not commence till at least some time after the mountain-making process had ceased in the other region. The one great geo-synclinal is of Palæozoic, the other is of Mesozoic age. The one mountain-mass belongs to the close of the Palæozoic, the other hardly began before the commencement of the Cainozoic, and was in process of making during the earlier half of that period. As yet, sufficient materials hardly exist for the classification and correlation of the greater earth-movements which have modified the physical structure of the European region, but they are gradually accumulating, and cannot fail some day to lead to most important results.

EXPLANATION OF PLATE XVII.

Fig. 1. Section cut from one of the more quartzo-felspathic layers in the contorted banded gneiss at the estuary of Le Pouldu. ($\times 27$.)

The figure shows one of the elongated irregular grains of felspar containing inclusions of quartz (left white), and with indications of cleavage-planes roughly at right angles to the longer axis of the grain. This lies in a ground-mass of granules of quartz and felspar (chiefly), the latter sometimes occurring in elongated streaks. (See p. 309.)

Fig. 2. Section cut from one of the more micaceous layers in the above-named rock. ($\times 27$.)

The figure shows the elongated felspar grains (as in fig. 1) broken and displaced. The rock contains crystals of mica of fair size and apparently original constituents, in the direction of which the cracks traversing the slide often run.

(For the DISCUSSION on this paper see p. 335.)

* On this subject there is a suggestive paper by Dr. Barrois in *Ann. Soc. Géol. Nord*, t. xi. p. 278. The central area (that now occupied by the western part of the English Channel) appears to have remained longest above water.

24. *The Rocks of SARK, HERM, and JETHOU.* By the Rev. E. HILL, M.A., F.G.S., Fellow and Tutor of St. John's College, Cambridge. (Read March 23, 1887.)

CONTENTS.



1. Introduction.
2. The Hornblende-schists.
3. The Creux-Harbour Gneiss.
4. The overlying Granitic Rock.
5. Veins and Dykes.
6. Herm and Jethou.
7. General Conclusions.

1. *Introduction.*—Sark, more fortunate than Guernsey, has the advantage of a good sketch map, which was published by Professor Liveing in vol. iv. of the 'Proceedings of the Cambridge Philosophical Society.' The account of the geology which accompanies that map notices the principal feature, one singular and possibly unique, namely a series of conspicuously banded hornblendic schists between an upper and an under gneissose series; that is to say, there seems to be a series which is presumably stratified in the midst of apparent gneiss. Thinking that such a succession might throw light on some problems of "metamorphism," I undertook a careful examination of the island; and the widespread interest now taken in 'Archæan' rocks emboldens me to give a brief account of my results. I owe a debt of gratitude to Professor Bonney for frequent and invaluable help.

The appended map (fig. 1) shows a diamond-shaped area about two miles long by one and a half broad, united at its southern end by a narrow isthmus to another about one mile long. This neck, called the Coupée, 200 feet above high-water mark and about 8 feet wide at the summit, is one of the island sights. The weather is rapidly cutting it down, and but for the roadway built up along its knife-edge the two areas would by this time be practically separate. Even between two of my visits a landslip had seriously increased the degradation. Previous writers have pointed out that the same action in a less advanced stage is proceeding at the northern extremity (by the cleft leading to the Boutiques Caves); while on the west the separation of Brecqhou is complete, and on the east rocks called the Burons are relics of the final stage. But, in truth, the like has been happening all round on every side; islets, rocks, and shoals in almost every direction are witnesses of the progress of destruction. The rock, though hard, is traversed by numerous fissures (usually faults of small throw), and to these are principally due, as well this destruction as also the abounding pillars, arches, and caverns which give to the scenery of Sark such singular charms. Guernsey boasts but a single cave of importance, while Sark has several of the first order, and not a bay there is without two or three of at least some interest and beauty.

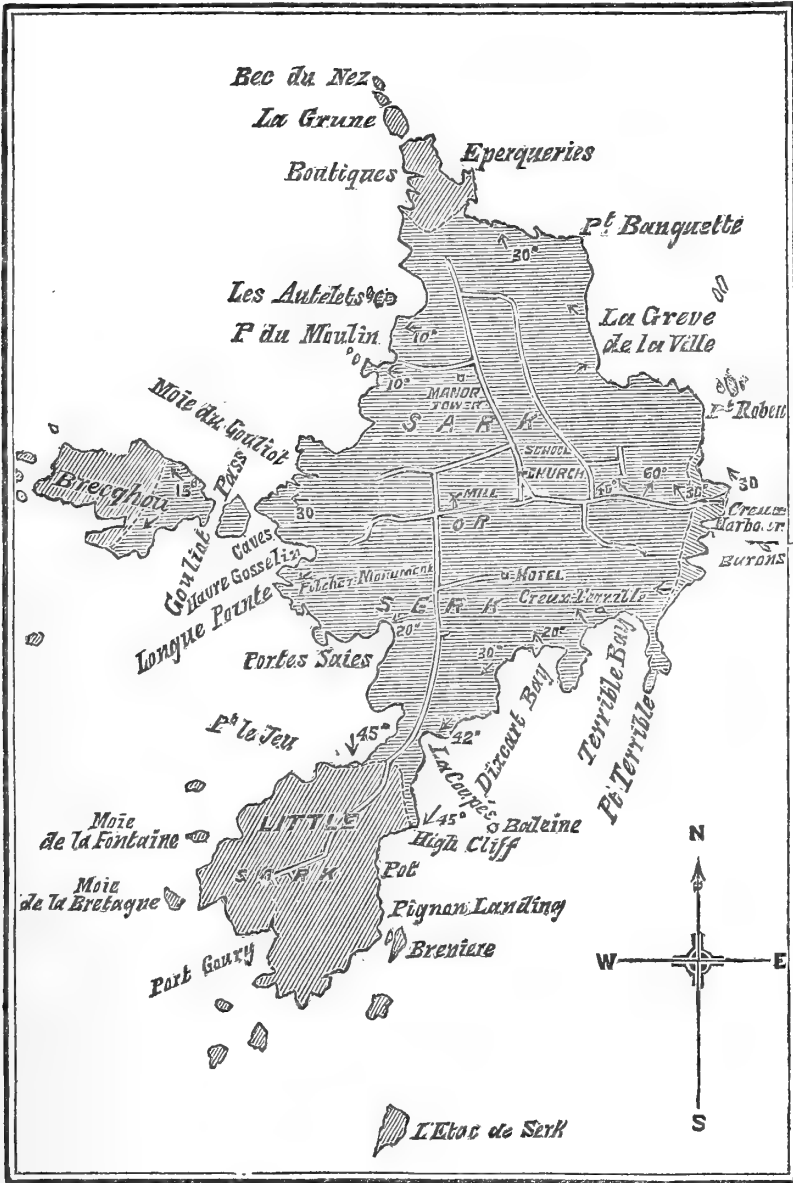
Fig. 1.—Geological Sketch Map of Sark and Neighbouring Islets.
(Scale 1 inch to 1 mile.)

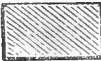
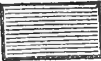

-  Creux-Harbour gneiss.
-  Hornblende-schist.
-  Granitic rock.

The interior of the island is a tableland, of which the highest point, 375 feet above the sea, is at the Mill. The cliffs rise in general to about 200 feet, but on the north and south, and also on the west of Brecqhou, there are slopes down to the sea. The base of the cliffs is seldom accessible, and except in a few of the bays no beach of any kind exists.

2. *The Hornblende-schists.*—The hornblende-schists, which form the greatest part of the island, may be studied in any of the accessible bays, but most conveniently at Port du Moulin, on the north-west coast, where they are also most typically displayed. Here cliffs about 150 feet in height, with an aperture pierced near their summit and a quarry at a somewhat higher level, give full opportunities of examination. The rock is beautifully banded in alternate dark and pale layers, which are often so fine and thin that an inch will contain four or five. The pale stripes are the narrower, and consist of felspathic material, with some occasional quartz. The darker bands consist, to the extent of two thirds at least and sometimes almost entirely, of hornblende in fine irregular grains, perhaps about $\cdot 02$ inch in longer diameter. At the base of the cliff the hornblendic bands thicken up to a foot or so, and have less admixture of other constituents. Their grains are coarser, reaching $\frac{1}{8}$ inch; and a parallelism in their lie gives a silky lustre on surfaces when split. In some of the lowest beds occur patches of aggregated lustrous black hornblende, in pieces $\frac{1}{4}$ inch long; as these are surrounded by a whitish border they are probably segregations. The general parallelism of the layers is not everywhere complete; some laminae are of varying breadth, others even lenticular; here and there a layer inclines down towards, and unites with, that below; thus there are indications of current-bedding, and these are confirmed by a section in the cliff at the northern corner of the bay, so clear and large as to leave no room for doubt (fig. 2).

Fig. 2.—“*False-bedding*” finely shown in *Hornblende-schists* at the north-east corner of *Port du Moulin, Sark*. (Height about 12 feet.)

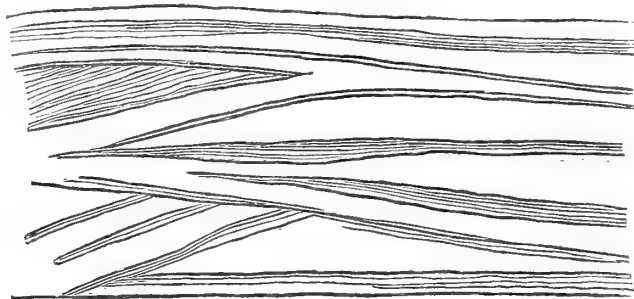

The beds here, at Port du Moulin, lie almost horizontal; the very gentle dip they have is westerly.

The beds of nearly pure hornblende just described lie in perfect conformity and continuity upon a thick bed of somewhat different appearance. This is composed, to nearly half its amount, of felspar in grains of about $\frac{1}{4}$ inch across, hornblende being only the second constituent in amount; black mica also occurs plentifully in rather minute flakes. At Port du Moulin a thickness of about 10 or 15 feet of this bed is exposed at low tide, but in a bay $\frac{1}{4}$ mile further south there is as much as 30 or 40 feet; no lower rock can be seen at

either place, and in each direction the dip carries it gradually out of sight.

The description above given of the series serves with sufficient correctness for the whole of the western coast, from Les Autelets to La Coupée, and for the beds on the island of Brecqhou. The cliffs of this iron-bound coast are very difficult of descent; they give a continuous section, but rarely grant a view of it; however, the outcrops along their upper edge show no more differences than weathering would naturally cause. In the Havre Gosselin (where landings are effected by an iron ladder up a rock, followed by a cliff scaled with the aid of ropes) the banding is not conspicuous, but will be seen on examination. At Port es Saies (where also a rope assists) the beds are banded just as at Port du Moulin, save that the bands are somewhat thicker. The dip, which was W. at Port du Moulin and almost nothing, is W.S.W. about 20° at Havre Gosselin and Port es Saies, and veers still more towards the south as the Coupée is approached. Just beyond this the beds dip at an angle of 30° due south, and pass below a higher formation, to be hereafter described. North of Port du Moulin the dip-directions have some north in them, and the disappearance takes place in the same manner beyond Les Autelets, but in a cleft which appears inaccessible, so that the succession cannot so well be observed.

The series as seen on the east coast is essentially the same as on the west. There are the same alternate bands of hornblendic and felsitic materials, only the texture is somewhat more sandy, and the bands not nearly so minute; the stripes range up to an inch or two of pale and a foot or so of dark. One specimen I have (from Dixcart Bay) is very coarsely crystalline, and somewhat reminds me of some of the coarsest felspathic grits of Charnwood. The beds are best seen in Dixcart Bay, and in the less accessible Bay Derrible (or Terrible), where a natural shaft (the Creux Derrible) gives a clear vertical section of more than 100 feet. One or two more quartzose beds, 2 or 3 feet thick, not unlike some of the Lizard granitoid beds, occur in the bay south of the Eperqueries, and must therefore belong to the summit of the system. At the Lizard there are successively in descending order a series including granitoid beds, a hornblendic series, and a micaceous series. In Sark we find a hornblendic series, with a few more quartzose beds near its summit, and low down (at Port du Moulin) a thick mass containing a good deal of mica. The similarity is curious, but can scarcely be more than a coincidence.

Round the Bay Derrible the dip is N.N.W., but in general along the east coast the beds incline westward in directions that radiate from the Creux harbour, the easternmost point of the island. As the highest point of Sark is 375 feet above the sea, these beds have a thickness of at least 400 feet; allowing for the dips, 600 seems probable, and there is a possibility of very much more.

The question of course suggests itself, What is the origin of these beds? I do not see how this uniform alternation of varying materials, with parallelism nearly perfect, yet occasionally interrupted,

and with varying thicknesses, so nearly horizontal over so great an area, with such a freedom from disturbance, can possibly be due to anything except successive deposition, which, however, need not necessarily have been subaqueous. The series bears an extremely close resemblance to the hornblende-schists of the Lizard. I have not, however, detected any of the "eyes" of felspathic material described by Professor Bonney, nor such minute and perfect current-bedding as is figured in his paper (Q. J. G. S. vol. xxxix. pp. 1-24). He mentions there the suggestion that the schists may be altered tuffs. Now if the question be asked, Can you show a source for the material? no answer can be given at the Lizard, but in Sark it is possible to make a suggestion. The singular mass of intrusive rock described in my paper on Guernsey as hornblende-gabbro is distant from Sark only six or seven miles, and consists of materials closely akin to these. Some of my specimens from Guernsey are scarcely distinguishable from some specimens of the very black layers from the beach at Port du Moulin, and the segregation-patches mentioned above have much in common with the "sun-burned" patches of the 'Birdseye.' I have not succeeded in finding any evidence of included fragments or agglomeratic structure; however, a distance of six miles is enough to account for the absence of all but rather fine materials.

No cleavage exists, another point of resemblance to the Lizard. About halfway down the valley which leads to the Creux Harbour the usual N.W. dips are replaced for a few yards by a very steep dip to the N.E.; thus there seems to be a roll. At the south side of the Point Terrible the beds are crumpled just over a cave. On the south side of the island of Brecqhou the beds show some contortions about two or three hundred yards before they dip under the superior rocks. The last two instances are only visible from a boat. All these indicate a nip between east and west forces; this agrees with the structure of the Guernsey gneiss and the appearances in the rock of Jethou. There are also some contortions which have different directions in the bay $\frac{1}{4}$ mile south of Port du Moulin and at the vanishing point on the north-west coast. These may be owing to either faults or intrusions, both of which are at hand in both places.

3. *The Creux Harbour Gneiss.*—The directions of dip throughout the hornblende-schist series, with exception of the brief roll just mentioned, are all more or less westerly, and, taken as a whole, radiate from the easternmost point of the island. Accordingly on the eastern side we should seek for the base of the series*. We find it. Let the visitor just landed on the pier detach his eyes from the singularity of the scene, and scrutinize the southern side of the cliff-wall which encircles the spot. He will see about halfway up the face a group of horizontal stripes, which subsequent examination shows to be part of the hornblendic series. But the rock beneath these is of entirely different aspect, homogeneous and massive.

Examined in hand-specimens this lower rock is highly crystalline, of moderate coarseness. It consists of pink and flesh-coloured felspar in

* Prof. Livinge places the lowest beds at Port du Moulin.

grains of 0·1 or 0·2 inch in diameter, which often aggregate together, glassy quartz of like size, and black or dark green hornblende. The microscope adds to these sphene and apatite. In colour and degree of coarseness it is not unlike some Leicestershire syenites from the Enderby and Sapcote group. Thus it might be called a granite, but for its very decided structure, which is visible even in hand-specimens as a parallelism of the grains and a tendency in the felspar to aggregate along parallel surfaces. In the lower part of the cliff this is especially conspicuous; for the structure weathers out into well-marked lines which indicate a dip of 30° in a N.W. direction. We may thus designate our subject of investigation a syenitic gneiss with a rather rude foliation. The rock passes out to sea, and appears to constitute the Burons, the Grand Moie, and possibly other isolated rocks. Southwards from the harbour it furnishes the face of the cliffs up to within a few feet from their crest all the way to Point Terrible, where it ceases abruptly. Northward it forms the base of the cliffs for a short distance, but sinks entirely out of sight some distance before Point Robert. Thus practically it can be examined only at the harbour; in a walk along the cliffs the foot treads nothing but schists; and as the appearances of dip differ little, I do not wonder that many visits had been paid to the island by others and by myself before the discovery was made that here is a new and different series.

Fig. 3.—*Hornblende-schists overlying Gneiss, seen across a cleft in the Cliff north of Point Terrible.*



The relations between this gneiss and the overlying schists are not altogether easy to establish. The junctions, though fully exposed, are all nearly or quite inaccessible. By passing along the cliff edge and venturing down some rather steep grass slopes a very near view can be obtained across clefts (fig. 3), and the harbour cliffs give an excellent section (fig. 4). The dip of the gneiss is exactly N.W., while that of the schists, so far as it can be estimated, is rather more nearly W. The passage from the one to the other is everywhere abrupt and definite to the eye. The highly quartzose gneiss must have had a very different origin from the quartzless hornblendic rocks. The nature and thickness of the immediately overlying beds seem to vary at different spots; and those in actual contact with the inferior

rock are often lenticular or lie irregularly upon it. The height of the junction above the sea varies greatly, but this plainly is for the most part due to faults. On the whole almost all the appearances point to an unconformable overlies, none are inconsistent with

Fig. 4.—*Hornblende-schists overlying Gneiss, Creux Harbour, Sark.*

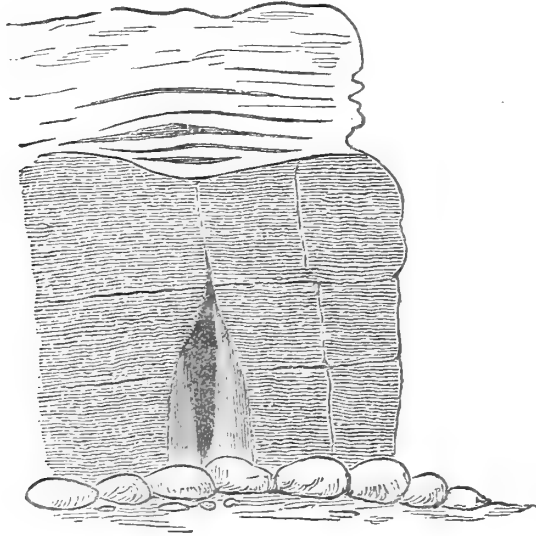

it, and I am convinced that this is the true account. The only appearance in favour of conformity is the rough general agreement in the dips of the two series. But I would suggest that the bedded structure in the gneiss may not be original, but one which has been developed by pressure, the pressure being in this case probably the weight of a superincumbent mass.

4. *The Overlying Granitic Rock.*—It has been mentioned that at both extremities of Sark the hornblende-schist series disappears below other rocks; the same also takes place in the island of Brecqhou on the west. These superior rocks are coarsely crystalline, containing hornblende and white felspar in grains 0·1 or 0·2 inch long, quartz often but not always, and black mica occasionally, especially, I think, where decomposition is in progress. The felspar shows plagioclase striping, sometimes even to the unaided eye. Much of the quartz is clearly secondary, occurring along strings and cracks, but much is in ordinarily distributed grains. The texture is very highly crystalline, as much so as that of any ordinary syenite or diorite. The structure and jointing are massive and irregular; there is no general appearance of bedding, nor any uniformity of divisional planes. Especially at the south end of Little Sark dark nodes occur, sometimes lenticular or oval, sometimes almost spherical, which consist of hornblende with some felspar in grains much smaller than those of the main mass. These appearances are all characteristics of an igneous origin. Nevertheless these rocks have been described as metamorphic gneiss, and, as will be seen, not without a good deal of justification, for the rock generally possesses a rude cleavage or ten-

dency to foliation. These structures sometimes appear vertical with N.-S. strike, but at Port Goury on Little Sark there is a platy structure which dips at about 30° to the south, just as bedding ought to do, and at the extreme north end, close to La Grune, a similar structure slopes gently to N.E., also a natural direction for bedding in that place. Again, wherever lenticular nodes occur their longer axes agree in direction with these structures, and though the rock is usually very homogeneous, yet occasionally long stripes show, and these too lie in the positions which strata might be expected to occupy. Some of these streaks are well developed at the extreme north end, on the slope leading down to the sea-neck. They are finer-grained than the mass of the rock; some are pink, some dark, some show a banded surface. They may reach several feet in length, with depth not exceeding an inch or two. I could not bring away a good specimen; but a specimen taken from near Les Boutiques shows a marked streaky structure. This last is such as might result from crush, but I hardly think the pink seams above described could be due to that cause. They are so long and thin that one can hardly believe them to be caught-up fragments*. There is a large dyke near, of which some might be offshoots; but no connexion is visible. I think, however, that this is the origin of some, and it is quite possible that all these suggested causes may have had shares in the appearances, and have produced, some one, some another. But on the hypothesis that these crystalline rocks are metamorphosed sediments, then these seams should be the last remnants of the stratified structure, and they are certainly explained more easily thus than on the igneous theory.

Each hypothesis, then, presents considerable difficulties. In hope of deciding the doubt, I endeavoured to examine carefully every visible junction with the underlying beds. There are six cliff-sections, four in Sark, two in Brecqhou, none of them easily accessible. The least difficult is that on the west side of Little Sark †. Here, except at high tide, the meeting of the two rocks can be well seen in the base of the cliff. The beds, highly hornblendic, dip S. at about 40° ; the upper rock has but little appearance of structure; between the two is a zone of intermixture about 10 feet wide, within which tongues and lenticular portions of crystalline rock are intermingled with the schist; but the general direction of the surface of junction agrees with that of the bedding-planes. A diorite-dyke close to the junction confuses some of the indications. The evidence on the whole is in favour of the upper rock being igneous, but I did not consider it conclusive.

The two northern junctions appear to be faulted. That on the west cliffs is beyond the north corner of the bay, near Les Autelets, and appears to be in a cleft which a climber cannot reach. There are some fallen blocks close to this cleft which seem certainly to contain

* Yet at Kerscou, N. of Morlaix, I was shown in 1886 a ribbon of schist 30 feet long and only $1\frac{1}{2}$ wide, torn off and imbedded in granite.

† A landslip has carried away the old path to the beach at the Coupée; a descent can be effected by a grassy couloir just beyond the neck.

a rock intruded into schists, but the intruder cannot be clearly identified with the overlier. So far as a boundary can be traced on the steeps above, this is sinuous and irregular. It is lost on the grassy summit of the island, but reappears on the eastern side, and the junction may be seen at low tide without much difficulty a little south of the Eperqueries. At the corner of the bay is a natural arch, and here on the side of the passage the line of meeting can be traced in an excellent section. On close scrutiny crystalline rock seems to have broken up and run into schist. But at this place also, as if to baffle inquiry, a dyke and a fault come together, and I doubt if a sceptic could be shown enough for his conviction.

Conclusive evidence is, however, afforded by the south-east junction (fig. 5). This occurs in Little Sark, on the south face of the "High Cliff" opposite the isolated rock called Baleine*. The schists

Fig. 5.—*Rough sketch of Granite overlying Hornblende-schists at south-east junction on Little Sark. Schists perfectly bedded, dipping S.W.*

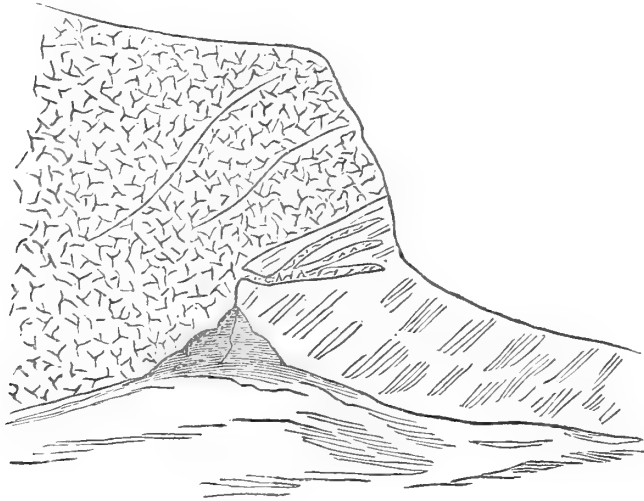

are highly bedded, dipping S.W. at 45° . The general surface of contact, as usual, agrees with the direction of the bedding-planes; but dykes can be seen to proceed from the main mass of upper rock and to ramify among the lower.

In the outlying island of Brecqhou also the hornblendic beds dip in a westerly direction below crystalline rock. On the south side a vertical cliff makes a clean section of the contact; the upper rock seems to lie, though very nearly, still not quite on a bedding-plane of the lower. In the cliff about 100 yards east is a large lenticular inclusion of crystalline rock differing scarcely at all from the upper rock, and probably, therefore, a dyke from it. On the north side of the island it is possible to stand on rock shelves and examine the

* A fair view may be obtained from a boat. The crags look inaccessible, but I believe a way down has been cut. I reached the spot from the creux called the Pot, at low-water spring-tides; this access would seldom be safe.

contact at leisure. The dip here is 15° or 20° N.W., and here also the massive rock makes a close approach to conformity, but on a small scale seems to cut across or run into the bedding; so that again in Brecqhou we have the same imperfect indications which just fall short of proof.

Yet the general conclusion from the junction-evidence, taken as a whole, even if we leave out that of the south-east junction, must, I think, be that these upper crystalline masses are not sedimentary rocks metamorphosed, but one igneous overflow. The near conformity in each case may be due to the granite having forced itself between beds as a direction of least resistance. But it seems to me also possible that an actual flow may have taken place over a surface nearly horizontal, and that the coarsely crystalline nature may be due to a higher temperature or other unknown circumstance of that prodigiously remote epoch. In either case denudation has had a protracted task to plane down through the superincumbent mass and lay bare the subjacent dome. There are difficulties, but they seem less than the difficulty of accounting for the invariable appearances of flow across the edge of beds, the apparent intrusive offshoots, and the sudden transition from a minutely banded series to a mass a thousand feet thick, with only phantoms of bedding which flee upon approach.

The overlying rocks in Brecqhou present remarkable features. At the furthest western point of the island they slope gently down to the sea, and show no greater differences from those at the extremities of Sark than rather more mica and somewhat greater decay. But along the southern cliffs, approaching the deep inlet conspicuous on the map, a structure begins to be extremely well marked and weathers out into deep furrows. The clean faces of hand-specimens show a banded arrangement of constituents such as is usually regarded as characteristic of a fine-grained gneiss. The dark materials gleam with mica, the white streaks are coarser and consist of felspar with some quartz. So far as I could see, the passage from the crystalline rock to this is gradual and continuous, so that the whole mass is one. I have unfortunately made only one examination of the spot; a boat has to be taken, and it is not always possible to land.

This gneissoid structure affords no valid argument in support of a metamorphic origin for the crystalline rock. If it should be proved separate, it would of course prove nothing one way or other. If, as I believe, it is continuous with that, then, since it is clearly a lower part, almost in contact with the schists, we should have to admit that metamorphism had been much less complete in the deepest-seated portion of the mass.

The banding shows corrugations visible even in hand-specimens, and becoming contortions of some magnitude towards the head of the deep inlet on the south coast. They lie N.-S., and are plain proofs of an E.-W. crush or nip, of which other indications exist. It would appear that this great squeeze produced more visible effects where the granite (assuming that this gneiss is crushed granite)

came against a westerly slope of schists than where, as at the north and south ends of Sark, the forces acted parallel to the planes of the junctions. This is the same as saying that the corrugations were produced where the upper rock, if it slid, would have to slide up a slope of the lower, but not where its slip could be horizontal. This would seem to show that the granite was the readier to yield; but, as has been mentioned, the schists also are in some places corrugated in the like direction; besides, the underlying unconformable gneiss may be near the surface and influential, though concealed.

5. *Veins and Dykes*.—A brief notice of the veins and dykes may be added to complete this account of Sark. It has been mentioned that faults abound; they have generally opened into fissures now filled with a reddish earthy material. These have been everywhere burrowed into in search of ores, but nothing has ever been found worth attempting to work except a vein of silver in Little Sark, and this has long been abandoned. Other veins are few.

The dykes have not nearly the variety seen in Guernsey. I have seen none of the granite dykes and elvans common there. A brownish microcrystalline quartz-felsite with microscopic mica occurs at the sea-end of Les Boutiques caves, and may be the same as the whitish decomposed intrusive dyke which has originated both the fissure and the cavern. A dyke six or eight feet broad cuts the rocks at the Eperqueries landing, a compact dark felsite with porphyritic felspar, showing under the microscope also a fair amount of mica. The pink rhyolites or glassy felsites of Guernsey and Jersey seem to be entirely wanting. The cliffs south of Dixcart Bay are traversed by some large dykes conspicuous from the water, but mostly inaccessible; I believe they are identical with a specimen collected in the Bay Terrible, which is a beautiful, highly crystalline syenite or diorite, with a good deal of epidote intermixed.

The majority of the dykes belong to the Guernsey group of basaltic or diabasic intrusions, and to that section which are of medium fineness. A slide cut from one of these which traverses the cliff near the Coupée is described by Prof. Bonney to me as "probably a hornblendic diabase rather than a true diorite."

There is a fine mica-trap dyke, a kersantite, at the N.E. corner of the cliffs of Port du Moulin, and apparently a smaller one much decomposed at the natural gateway in the southern wall of that bay. There seem also traces of another in the road-cutting at the Coupée; doubtless others may be found.

6. *Herm and Jethou*.—As these two small islands lie between Sark and Guernsey, which I have already described, it may be convenient to append here a brief account of them. Herm, the northern, is the larger, about $1\frac{1}{2}$ mile long and $\frac{1}{2}$ mile broad. Jethou, the southern, is separated by a narrow but deep channel, and though not one quarter the size of Herm, is rather higher. Both consist of a beautiful crystalline white rock, usually regarded as a granite. Jethou possesses a faint foliation in N.-S. vertical planes, and Herm also shows a tendency to the same structure at its end nearer Jethou. On the east side of Jethou is a very fine raised beach,

15 feet above high-water mark, four or five yards thick, a mass of rounded pebbles in general as large as a man's head, but some of them two or three feet across. In the south-east of Herm is a fine "creux." This name is generally applied in these islands to a shaft in the hill-side communicating at its bottom with the sea; but the Creux Mahie in Guernsey is a cave, and at the Creux Harbour in Sark there is now at all events only a tunnel through the rocks. On the south-west shore of Herm, below some cottages, a greenish compact seam, often less than half an inch wide, runs for many yards through the granite, and becoming wider shows its real nature by developing into an ordinary compact dyke. This helps to explain some of the appearances noted in the Sark granite. In Jethou in like manner there are a few platy dykes, and a small much-decayed dyke of mica-trap which shows its later date by traversing one of the above. The singular "shell beach" at the north end of Herm, the only one of the kind in these islands, illustrates the local nature of fossil accumulations.

The granite of Herm is a highly crystalline rock, consisting of white felspar, both orthoclase and plagioclase, hornblende, quartz, and biotite, with a little apatite; in my slide mica encloses a hornblende crystal. The felspar often shows plagioclase striping even to the unaided eye, but generally is rather amorphous; it occurs in grains about $\frac{1}{8}$ inch long, but runs up to half an inch or more in some specimens. The hornblende is in well-formed crystals, often rather lath-shaped, but seldom exceeds $\frac{1}{8}$ inch. The quartz is in the usual interstitial glassy grains. The mica is the least abundant of the principal constituents; it shows well-shaped hexagonal plates. Dark nodes are frequent, and vary much in shape and in sharpness of definition. The rock of Jethou is much the same as that of Herm, both to the eye and under the microscope; but Prof. Bonney remarks to me on a slide that it is a little crushed, while a slide from Herm shows no crushing. But, as above mentioned, on a large scale there is a very faint structure visible also in Herm at the end nearer Jethou. Prof. Bonney writes of both that they are holocrystalline and indubitably igneous.

7. *General Conclusions.*—Comparing these granites of Herm and Jethou with the granitic overlying rock of Sark described above and shown also to be igneous, the differences appear very slight and smaller than may be found in less widely separated parts of many continuous masses of granite. The probability, then, seems considerable that they are all remnants of one great irruption. No Jersey rocks that I know, and none of the principal Guernsey rocks, appear to be the same as these; but the granite of Alderney, which I hope at some future time to describe, I expect will prove also to belong to this great mass. Certainly some of my specimens could not be distinguished as different. If so, since Alderney, the northernmost island, shows no sign of crushing, while Herm and Jethou exhibit faint traces, and Sark, the southernmost, presents clear proofs of compression, it would seem that the compressing forces had acted more powerfully in the south of the area concerned.

The order of geological events in Sark thus appears to have been as follows:—A mass of Archæan rock of uncertain origin had deposited on it a thick series of beds of alternating materials, principally hornblendic, possibly of volcanic origin. Over these (whether other beds had also been superposed cannot now be discovered) a mass of granitic or syenitic igneous rock subsequently flowed. After the solidification of this, but still probably at a very early period, came a great east and west nip. Except the intrusive dykes there are no later materials with which to continue its history.

The physical geology of Sark affords many interesting subjects of study. The apparently homogeneous granite, contrary to what might be expected, decomposes much more readily than the banded hornblende-schists. I have been inclined to fancy that on all sides of the island there is a tendency for rock masses, in fault-throws in fissures or in slides, to lean away from the central mass. This may be due to the domed arrangement of the beds, or may have followed the cessation of the nipping force and be a result of elasticity, or it may be simply caused by the undermining of the sea. The Coupée is due to a fault and fissure-vein which form a case in point; and the celebrated Gouliot caves appear to be due to a slide of this nature. More generally, however, the caves have originated in dykes, as have the Boutiques, and, I think, the Creux Terrible.

The Archæan age of these rocks is not likely to be contested by many. They are analogous in structure to admittedly pre-Cambrian rocks elsewhere. They seem distinctly older than the unfossiliferous argillites of Jersey, themselves of extreme antiquity, and, I believe, unlike any neighbouring even Cambrian beds. And the series of the Finisterre beds, which I had the opportunity of seeing this year under the guidance of Dr. Barrois, contains in the whole succession, from Carboniferous down to Cambrian, nothing that can be compared to them. The only rocks I saw there capable of being classed along with the Sark schists were some beds at Pouldu south of Quimperlé, which in the French Geological map are themselves marked as pre-Cambrian.

It may, however, be suggested that their highly crystalline condition is due to the influence of the vast mass of granite by which they have been overflowed. I am not sure but that this cause may have had some effect. However, in the first place the beds nearest the granite are not everywhere the most highly crystalline. Secondly, in the neighbouring region of Brittany I had in 1886 the opportunity of studying, under Dr. Barrois's guidance, the effects produced by intrusive granites on a number of widely differing rocks of almost every age, and none of these were metamorphosed into any resemblance to these hornblende-schists. Thirdly, the only rocks of that region which resembled the Herm-Sark-Alderney granite that overlies these schists are granites which Dr. Barrois, on independent evidence, considers Cambrian at latest.

To myself the most interesting feature in Sark is the unconformable overlies of the hornblendic beds on older gneiss. Several observers have lately brought forward convincing proofs that certain gneisses

and schists formerly regarded as metamorphosed sediments are really igneous rocks in which banding has been developed by crush. In the usual fervour of conversion some writers seem rather desirous, if they can, to account for everything this way. It may be a useful warning that here in Sark we find a series which cannot have been so produced.

DISCUSSION.

The PRESIDENT remarked on the value attaching to Prof. Barrois's work in Brittany, and on the interest of the observations made on the country by Prof. Bonney. The conclusions as to the Archæan age of the lower gneissose rocks would probably be generally accepted; but a question which must still be regarded as an open one was, whether foliation ever corresponded with original bedding. The supposed instances of unconformity and current-bedding depended on the assumption that such was the case.

Mr. BECKER said that certain rocks of California which he had studied were of Neocomian age and sedimentary origin, and, despite a certain dissimilarity, there was a remarkable petrographical resemblance. Amphibolites and other metamorphic rocks were common, and diabases and diorites abounded. The diorites passed into amphibolites; glaucophane occurred in the latter, and glaucophane-schists resulted from altered shales, the positions of the glaucophane-prisms resulting from schistosity of the shales and being related to the original bedding-planes. He had remarked transitions between glaucophane and actinolite.

Mr. RUTLEY remarked on the probable extension in former times of Archæan, Cambrian, and Silurian rocks from Brittany and the Channel Islands through Devon and Cornwall and Wales. He considered that there might be cases in which foliation denoted original bedding, as in one of the instances suggested by Mr. Hill, in which it seemed that the hornblende-schist might consist of materials derived from the degradation of eruptive rocks. The later stresses in these old rocks may have obliterated the evidence of earlier action of the same kind.

Mr. HILL said, with reference to Prof. Bonney's remarks on the difficulties found in mapping the region, in which he concurred, that one advantage was the absence of travelled blocks. He remarked on the curious arkose-like appearance of the crushed rocks on the coast south of Quimperlé. He quite agreed that there was an ancient Archæan base to the rocks of Brittany.

Dr. HICKS said that in Great Britain gneiss and other rocks of the character of those on the table from Brittany and the Channel Islands were only found in the Archæan series. The most important question, *i. e.* as to the age of these rocks, seemed therefore to be completely settled by these researches. He was inclined to doubt whether the supposed false-bedding of Port du Moulin was really due to deposition. He had described certain breccias in Wales that might explain the conditions exhibited by the crushed gneisses described by Prof. Bonney.

Prof. BONNEY, in reply, said he considered glaucophane merely a peculiar variety of hornblende. It would require very strong evidence to convince him that sandstones and similar rocks did ever pass into serpentine &c. With regard to Mr. Rutley's remarks, he could see no evidence in Brittany of important disturbances from Cambrian times till after the Carboniferous era. The questions raised by Mr. Hill had been treated in the paper; the arkose-like rock turned out to be gneiss clearly crushed *in situ*. He agreed with Dr. Hicks that the appearances of false-bedding in metamorphic rocks were of doubtful origin, but in some cases other explanations presented great difficulties, and sedimentation of some sort was probably to be detected in Archæan rocks.

Mr. HILL said the appearance that he referred to false-bedding occurred, not in gneiss, but in the overlying hornblende-schists. The possibility of these hornblende-schists being tuffs had occurred to him, but he had not been able to discover any evidence.

25. On TERTIARY CYCLOSTOMATOUS BRYOZOA from NEW ZEALAND.

By ARTHUR WM. WATERS, Esq., F.G.S. (Read May 11, 1887.)

[PLATE XVIII.]

THE Chilostomata have already been described in this volume of the Journal, p. 40, and therefore it is not necessary to repeat particulars about the localities.

This part I have kept back, hoping that the results of the 'Challenger' Expedition might throw some light upon this unsatisfactory suborder; but Mr. Busk's second part of the Report is a great disappointment in this respect, as only thirty-three species are recorded, and these are for the most part well known and common. In fact, the results of this great expedition do not seem, so far as the Cyclostomata are concerned, to exceed what I presume a specialist might, after a storm, collect in a few morning walks in the neighbourhood of the Sydney Harbour.

We do not seem to make much progress with the discouraging Cyclostomata, or to obtain fresh characters upon which classifications can be based, and in fact there are a few New-Zealand fossils concerning which I cannot pronounce a definite opinion as to whether they really belong to the Bryozoa or not. However, although not satisfied with our means of classification, any fossils which can be readily recognized should be described, as, besides being useful stratigraphically, fuller acquaintance may gradually set us in the right lines.

I would propose that we should divide the Cyclostomata into two subdivisions, namely, first, the *Parallelata*, or those in which the surface of the zoarium is to a considerable extent formed of the lateral walls of the zoecia, of which *Crisia*, *Entalophora*, *Diastopora*, and *Tubulipora* may be taken as types; and, secondly, the *Rectangulata*, or those in which the zoecia or cancelli open for the most part at right angles to the axis or surface of the zoarium or subcolony, of which *Heteropora*, *Lichenopora*, &c. may be taken as typical.

We are met with the fact that there are several cases of genera having similar zoarial appearance which must be separated into these two divisions; for instance, there is the true *Idmonea*, as *I. Milneana*, with the zoecial walls parallel for the greater part with the zoarial axis and the wall minutely perforated; and, on the other hand, with a similar zoarial appearance, *Crisina cancellata* has medium-sized interstitial tubes between the zoecia, both opening at right angles to the surface.

We have already seen Cyclostomata and Chilostomata quite similar in mode of growth, and in fact in this respect resembling even animals of other classes, so that we need not be surprised at finding such similarity in two subdivisions.

There are cases where, in badly preserved fossils with large pores, it may be difficult to distinguish whether these are interstitial or merely perforations in the shell-wall; but when sections can be

Out of the 28 species or varieties 18 are known living, 6 at least from New Zealand, 10 from either New Zealand or Australian waters, and 8 have been found fossil in Australia. This brings the number of Chilostomata and Cyclostomata up to 106; and the second part entirely agrees with the first in indicating that they are comparatively recent.

In figs. 1, 4, 14, 15 (Pl. XVIII.), the size is taken from photographs which were used, and study photographs of several species mentioned are deposited with the Society.

1. *IDMONEA SERPENS* (L.).

For synonyms see Hincks, Brit. Mar. Polyz. p. 453, pl. lxi. figs. 2, 3; pl. lx. fig. 2; and Pergens, Plioc. Bry. von Rhodos, Ann. Nat.-hist. Hofmuseums, vol. ii. p. 5.

Some fine specimens from the Petane Marls are entirely adnate on an oyster-shell, throwing out numerous strap-shaped rays.

The ovicells in recent Naples specimens occur below the junction, spreading downwards, and with a broad funnel-shaped opening.

Loc. Living: European Seas; New Zealand. Fossil: Pliocene of Sicily and Calabria; Waipukurau; Petane Marls; Tommy Gully (Petane); near Napier.

2. *IDMONEA RAMOSA* (d'Orb.).

Reptotubigera ramosa, d'Orb. Pal. Fr. p. 754, pl. 751. figs. 1-3.

? *Proboscina Eudesi*, Haime, Bry. Foss. de la Form. Jurassique p. 167, pl. vi. fig. 9; Pergens & Meunier, Annales Soc. Roy. Malac. de Belgique, vol. xxi. p. 217.

This grows much like *Idmonea serpens*, and at one time I thought that the specimens were only worn examples of that species; but the zoecial tubes are scarcely raised and equidistant, whereas in *I. serpens* the central zoecial tubes are much raised and connate, with outlying separate zoecia. The series are about 0.5 millim. apart. In one specimen, from near Napier, more considerable expansion takes place; and this form at one time I separated as *I. continuata*. This last grows much like *Tubulipora lobulata*, but the rays are in series.

Loc. Fossil: Cretaceous; Waipukurau and near Napier.

3. *IDMONEA CONTORTA*, Busk.

Idmonea contorta, Busk, Cat. Mar. Polyzoa, pt. iii. p. 12, pl. viii.

A specimen from the neighbourhood of Napier forms an anastomosing mass. The branches are about 2 millim. across, and in section are subtriangular, somewhat rounded on the dorsal surface. The series are about 0.8 millim. apart, with 6 or 7 zoecia in a series; dorsal surface with fine longitudinal lines.

The surface is so much worn that it is impossible to judge how much the zoecia projected.

Tennysonia stellata has a row of zoecial pores, between which there are cancelli. Before comparison with the British-Museum

specimen I was in doubt as to whether *Tennysonia* might be *I. contorta* or *Crisina cancellata*.

Loc. Living: Algoa Bay. Fossil: near Napier.

4. *ENTALOPHORA INTRICARIA* (Busk). (Pl. XVIII. figs. 5 & 6.)

Pustulopora intricaria, Busk, Cat. Mar. Polyzoa, pt. iii. p. 22, pl. x. figs. 1 & 4; Haswell, Cyclost. Polyzoa of Port Jackson, Proc. Linn. Soc. N. S. W. vol. iv. p. 352.

A small fragment from Shakespeare Cliff, Wanganui, is without any doubt the same as a recent *Entalophora*, which is apparently not uncommon in New-Zealand and Australian seas. It frequently anastomoses and forms dense intricate masses; the zoaria are about 1·5 millim. in diameter, and the zoecia are irregularly placed, often bulging out towards the end, but become narrower again at the aperture, which is about 0·13 millim. wide.

In the zoecial tubes there are always a large number of minute rays with club-shaped heads, on which there are numerous tubercles. I have called attention (Ann. Mag. Nat. Hist. ser. 5, vol. iii. p. 276) to similar rays in *Lichenopora radiata*, and pointed out that these rays, or "hair-like teeth," had globular terminations; and in that species there are fewer tubercles on these heads, in fact they are usually cruciform. Professor Nicholson has figured and described similar rays in *Heteropora pelliculata*, Waters; and these I have also figured in this Journal, vol. xl. pl. xxxi. fig. 28, but have not yet been able to see that the heads are tuberculated. They also occur in a species of *Tubulipora*, besides *Lichenopora pristis*, MacG., *L. cancellata*, *L. radiata*, and *L. Houldsworthii*, B.

The size and arrangement of the zoecia are similar in the recent and fossil examples; and, after having made the determination by these characters, it was no small satisfaction to find that in the zoecial tubes these minute rays were preserved, thus confirming the absolute identity of the two.

Loc. Living: New Zealand; Port Phillip and Port Phillip Heads (W.); New South Wales (H.). Fossil: Wanganui (base of Shakespeare Cliff).

5. *ENTALOPHORA WANGANUIENSIS*, sp. nov. (Pl. XVIII. fig. 1.)

Zoarium 2·5 millim. in diameter; about ten zoecia in a complete series. Distance of series about 1·2 millim. apart. The ends of the zoecia but slightly projecting; surface pitted, with small pores in the centre of the pits. The zoecia are very distinct and rounded, giving the whole a columnar appearance, and are usually arranged round the zoarium in a verticillate manner; but sometimes the arrangement becomes irregular. The closure, which occurs at about the level of the border of the zoarium, is present in many of the zoecia, and has numerous large perforations. This has as large zoecia (aperture 0·4 millim.) as any Cyclostomata with which I am acquainted, being about the same size as those of *Cinctipora elegans* of Hutton; but in that species the zoecia do not project at all, nor are the ends

tubular, but cut off straight. I am in doubt as to whether *Cinctipora elegans* is really Bryozoan.

Loc. Fossil: Shakespeare Cliff (Wanganui).

6. CINCTIPORA ELEGANS, Hutton.

Cinctipora elegans, Hutton, Cat. Mar. Moll. p. 103; Manual of the New Zealand Moll. p. 198.

Professor Hutton has sent me some recent specimens from New Zealand, and these exactly correspond with the fossil. The appearance is somewhat the same as that of *Entalophora*, but the zoecia do not project, and are cut off straight at the surface of the zoarium. The branches are about 2 millim. in diameter, and the zoecia are very large (0.2 millim. wide), arranged in a spiral manner, opening diagonally to the surface; about 12 cells form a complete spiral. Although it is placed among the Bryozoa, it must be pointed out that its relationship is not proved. The external portion of the shell is formed of thick fibrous layers in a manner which is not usual in *Entalophora*, and there are few external pores. There are connecting pores in the interior. This is closely related to *Cylindropora areolata*, T.-Woods, placed by that author among the Hydrocorallinæ (Palæont. of New Zealand, p. 21), and which also occurs fossil near Napier. In this last the openings are more vertical to the surface, and it is larger, with a more solid shell; but it would seem sufficient to separate it as var. *areolata*. *Spiroporina immersa*, Woods, may also be allied; but this is a species with which I am unacquainted.

Loc. Living: Wellington (New Zealand). Fossil: near Napier, Waipukurau.

7. HORNERA FRONDICULATA (Lamx.).

Hornera frondiculata, Waters, Quart. Journ. Geol. Soc. vol. xl. p. 687; Busk, 'Challenger' Report, pt. ii. p. 15; Pergens, Plioc. Bry. von Rhodos, p. 6.

Loc. Oligocene, Latdorf &c.; Pliocene, Crag, Italy and Sicily; Curdies Creek, River-Murray Cliffs, Bairnsdale, Mount Gambier, Shakespeare Cliff (Wanganui). Living: Mediterranean, Cape Verd, 100-120 fathoms.

8. STOMATOPORA GRANULATA (M.-Edw.).

Alecto granulata, M.-Edw. Mém. sur les Crisies &c., Ann. Sc. Nat. 2^e sér. t. ix. p. 205, pl. xvi. fig. 3; Busk, B. M. Cat. p. 24, pl. xxxii. fig. 1; 'Challenger' Report, p. 22.

Stomatopora granulata, d'Orb. Pal. Fr. p. 836, pl. 628. figs. 5-8.

? *Stomatopora incrassata*, d'Orb. ibid. p. 837, pl. 628. figs. 9-11.

Stomatopora ramea (Blainv.), d'Orb. ibid. p. 842, pl. 630. figs. 9-12.

Stomatopora minima, Römer, Polyp. des nordd. Tert. Gebirges, p. 22, pl. iii. fig. 1.

Recent specimens from New Zealand and fossils from Waipukurau correspond in size, being about 0.15 millim. wide, with an aperture

0·12 millim. The width of the zoëcia remains constant throughout the length, which is usually about 1 millimetre.

A specimen from the Valangian of St. Croix (Jura) is about the same size, but the zoëcia commence much narrower and then widen out.

Loc. Living: British and Northern Seas, New Zealand; Tristan d'Acunha, 60–90 fathoms. Fossil: Cretaceous (Valangian and Senonian) of Europe; Oligocene, Sollingen; Waipukurau.

9. STOMATOPORA MAJOR (Johnst.).

Alecto major, Johnst. Brit. Zooph. 2nd ed. p. 281, pl. xlix. figs. 3, 4; Seguenza, "Le Formaz. Terz.," Accad. dei Lincei, cclxxvii. p. 297.

"*Proboscina intermedia*," Novák, Bry. der Böhm. Kreideformation, Denkschr. k.k. Akad. vol. xxxvii. p. 102, pl. v. figs. 1–13.

For other synonyms see Hincks's Brit. Mar. Polyzoa, p. 427, pl. lviii. and pl. lxi. fig. 1; Pergens, Plioc. Bry. von Rhodos, p. 9.

The branches are 0·8–1·0 millim. wide, and the zoëcial aperture is about 0·12 millim., the extremities sometimes in irregular transverse rows. This is very much like *Proboscina crassa*, Römer, in d'Orbigny, Pal. Franç. p. 848, and perhaps should be united to it.

Loc. Living: British and Northern Seas; Queen Charlotte Islands (*H.*). Fossil: Cretaceous of Bohemia; Crag, England; Pliocene (Astian) of Calabria; near Napier; Waipukurau; Tommy Gully (Petane); and Trig Station.

10. STOMATOPORA DILATANS (Johnst.).

Alecto dilatans, Johnst. Brit. Zooph. 2nd ed. p. 281, pl. xlix. figs. 5–8.

For synonyms, see Hincks, Brit. Mar. Polyz. p. 429, pl. lvii. fig. 3.

Is not this *Criserpia dichotoma*, d'Orb.?

Loc. Living: Northern Seas. Fossil: Crag, England; Tommy Gully (Petane); Trig Station.

11. DIASTOPORA SUBORBICULARIS, Hincks.

Diastopora suborbicularis, Waters, Quart. Journ. Geol. Soc. vol. xl. p. 689.

A specimen from near Napier has both zoarium and zoëcia about twice the size of those of the following species. The ovicells are large, enclosing several zoëcia and radially elongate.

Loc. Living: British and Northern Seas. Fossil: Muddy Creek, Mount Gambier (Australia); near Napier and Tommy Gully (Petane).

12. DIASTOPORA SARNIENSIS, Norm., var. PERANGUSTA, nov.

A fossil from Waipukurau and a recent specimen from New Zealand are identical in size, the zoarium being 0·25 millim. in diameter. The zoëcia radiate irregularly from the centre, with the outlines very distinct and the ends erect; the younger zoëcia run by the side of the older ones for some distance, thus causing the zoëcia

to be less crowded than is usually the case. The zoecial tubes are very narrow, only about 0·06 millim., with the slightly elliptical aperture about 0·04 millim., and these very small zoecia are only about half the size of those of typical *D. sarniensis* from Guernsey. The fossil is without an ovicell, but the recent specimen has them transversely elongate. The zoarial appearance is somewhat the same as in *D. obelia*; and in the fossil there are closed cells, with a tubule projecting from the centre of the cover.

Loc. Living: New Zealand. Fossil: Waipukurau.

13. TUBULIPORA DIMIDIATA (Rss.).

Defrancia dimidiata, Reuss, Foss. Polyp. d. Wien. Tert. p. 39, pl. vi. fig. 6.

Pavotubigera dimidiata, Waters, Quart. Journ. Geol. Soc. vol. xl. p. 691.

Loc. Fossil: Miocene of Austria and Hungary; Mount Gambier; Trig Station.

14. TUBULIPORA CAMPICHEANA (d'Orb.). (Pl. XVIII. fig. 15.)

Multifascigera Campicheana, d'Orb. Pal. Franç. p. 688, pl. 762. figs. 7-9.

This, like *T. biduplicata*, occurs in strap-shaped expansions, sometimes quite separate, sometimes confluent; and then often the lines of growth can scarcely be followed. Here, instead of the zoecia occurring in uniserial rows, they are in fasciculi alternate on each side of a mesial line; on each side of the principal row and in the line of the fasciculi are one or two zoecia as outliers.

The growth is so similar in this and the next species that at one time I was not sure if they should be specifically separated; but this form is much stouter, having the series 1 millim. apart, whereas in *T. biduplicata* they are only 0·5 millim. apart. In those parts of the colony where the growth is the least regular, the appearance is just the same as in the St.-Croix specimens, and I think it must be considered identical with the Jurassic species. A specimen in the Lausanne Museum, from St. Croix, has very distinct hexagonal divisions between the zoecia, and in the New-Zealand fossil similar divisions are found in some parts.

The oecia are large, occurring in various parts of the zoarium, but usually near the end, including the series on each side of the mesial line, and usually in about three double series.

Loc. Fossil: Valangian of St. Croix; Petane; Waipukurau; Napier.

15. TUBULIPORA BIDUPLICATA, sp. nov. (Pl. XVIII. figs. 12 & 14.)

Zoarium adnate, branches broadly ligulate or united at the base, forming a continuous crust. Zoecia arranged on each side of a mesial line in parallel transverse rows opposite or alternate, usually two or three zoecia in a row, but occasionally, as at the dichotomization, in isolated fasciculi; on each side of these principal rows, and in the line of the series, are one or two zoecia as outliers.

This is a most interesting species, as numerous specimens show great range of variation, and we also see how artificial our generic divisions are, for I should have been justified in placing this under *Idmonea*. It is probable that *T. fasciculifera*, Hincks (Ann. & Mag. Nat. Hist. ser. 5, vol. xiii. p. 35, pl. ix. fig. 6) is a variety of this species; and the unconnected colonies remind us of *Reptofascigera alternata*, d'Orb.; while those that are continuous over a large surface resemble *Multifascigera Campicheana*, d'Orb. It is also closely allied to *Fasciculipora gracilis*, MacG.; but the very long bundles of zoëcia, connate for their greater length, show that this last must certainly be looked upon as specifically distinct.

A specimen from near Napier extends over a space of about 3 centim. across, and has extensive oöcial inflations, enclosing about 4 series, and wider than a ligula.

A fine recent specimen from New Zealand, in Miss Jelly's collection, has the subcolonies widely flabellate, instead of strap-shaped, and the spaces between the zoëcia are, in places, divided into angular or hexagonal divisions. The zoëcia are usually uniserial, but sometimes fasciculate. The small fragment from Port Phillip has the zoëcia close together without any space between.

Loc. Living: Port Phillip, Victoria (*W.*); New Zealand (*W.*).
Fossil: Tommy Gully (Petane); Napier; Waipukurau, Trig Station; Petane Marls.

16. FASCICULARIA TUBIPORA, Busk.

Fascicularia tubipora, Busk, Crag Polyzoa, p. 130, pl. xxi. fig. 1.

The fossil from near Napier is one inch across, but is clearly only a fragment of a large piece. "The horizontal, tabular, concentric laminæ" are nearer together than in the Crag specimen; but with this exception I see no difference.

A recent *T. tubipora* in Miss Jelly's collection has a few funnel-shaped openings on the laminæ. These may be ovicellular openings, but a division across the narrower diameter raises doubts as to the function.

Loc. Living: New Zealand? Fossil: C. Crag (*B.*); Red Crag (*B.*); Pliocene of Rametto, Sicily (*W.*); near Napier.

17. SUPERCYTIS DIGITATA, d'Orb.

Supercytis digitata, d'Orb. Pal. Franç. p. 1061, pl. 798. figs. 6-9; (?) Waters, Quart. Journ. Geol. Soc. vol. xl. p. 692, pl. xxxi. figs. 22, 26, 27; Busk, 'Challenger' Report, vol. xvii. p. 29, pl. v. fig. 3; (?) Reuss, in Geinitz, Elbthalegebirge, vol. i. p. 123, pl. xxx. fig. 5; Reuss, *ibid.* vol. ii. p. 136; (?) Pergens et Meunier, Bry. Garumniens de Faxe, Ann. Soc. Roy. Malac. de Belgique, vol. xxi. p. 221.

Fasciculipora digitata, Busk, Cat. Mar. Polyzoa, p. 37, pl. xxxiii. fig. 1.

The New-Zealand fossils are undoubtedly the same as the recent forms found by the 'Challenger,' although smaller and with a variable number of digitate lobes, averaging, however, about twelve; the

central zoecia are in long rows or groups, as described by Busk (fig. 3). We are not yet in a position to say whether the fossil specimen from Murray Cliff, which has the central zoecia regularly distributed, should or should not be separated on this account.

Mr. Busk makes me responsible for the locality "South Australia" for the fossils; but this is clearly a slip on his part for Victoria, the only locality from which I have seen it fossil except New Zealand. He has also made a slip in the measurements of the zoarium, which should be 12×8 millim., not 0.12×0.8 millim.

The basal growth consists of a central portion formed of large tubes, around which are much smaller tubes, opening at right angles to the axis of the zoarium, with hexagonal or irregular angular openings.

There is a specimen from Napier, which certainly seems to be this species, but it is without central cover and is much worn. It consists of subcolonies growing from one base.

Loc. Living: New Zealand. Fossil: Shakespeare Cliff (Wanganui). This or an ally from the Cretaceous of France; Faxoe; Strehlen; the Cenomanian of Saxony; and Victoria.

18. LICHENOPORA RADIATA (Aud.).

Lichenopora radiata, Waters, Quart. Journ. Geol. Soc. vol. xl. p. 694; Pergens, Plioc. Bry. von Rhodos, p. 10.

Loc. Living: British Seas; Mediterranean; Australia. Fossil: Pliocene of Europe; Australia; Waipukurau.

19. LICHENOPORA HISPIDA (Flem.).

Lichenopora hispida, Waters, Quart. Journ. Geol. Soc. vol. xl. p. 694; 'Challenger' Report, vol. xvii. p. 26; Pergens, Plioc. Bry. von Rhodos, p. 10.

Loc. Living: European Seas; Australia; Tristan d'Acunha, 100–1100 fath. Fossil: Miocene; Eisenstadt and Mörbisch. Crag; the Pliocene of Calabria; Mt. Gambier; Bairnsdale; Muddy Creek; Murray River; Wauru Ponds; Waipukurau; near Napier.

20. LICHENOPORA CLYPEIFORMIS (d'Orb.).

Tubulipora clypeiformis, d'Orb. Voyage dans l'Amérique Méridionale, vol. v. p. 19, pl. 9. fig. 5.

There are some thick pieces of a confluent *Lichenopora* from near Napier, in which the distinct central zoecia are raised into a mound, and start from the centre of the subcolony, thus leaving no central space. The peripheral zoecia are less distinct, and this portion resembles *L. hispida*. The zoecia are 0.07 millim., and the interstitial pores 0.04 millim., both being smaller than in *L. hispida*. This much resembles *Bimulticavea variabilis*, d'Orb., but differs from the Aldinga specimen in size, the centre of each colony being only about 3 millim. from the centre of those round it, and the zoecial and interstitial pores, as mentioned, are also smaller. Pro-

bably *L. variabilis* is allied to *L. pristis*, which in some subcolonies shows a tendency to multiserial rays.

Loc. Living: Iles Malouines. Fossil: near Napier; Waikato.

21. *LICHENOPORA WANGANUIENSIS*, sp. nov.

The specimens from Wanganui are in single disks, about 5 millim. wide, with 10–20 multiserial rays. The whole of the centre tumid, with the tumid portion extending between the rays. The covering of this part is reticulated, with a calcareous finely perforated crust between the bars of the reticulation. Zoöcial openings about 0.13 millim. wide.

Lichenopora wanganuiensis, sp. nov.; *semi-diagrammatic*, to show the tumid central area. (Enlarged 7 diameters.)

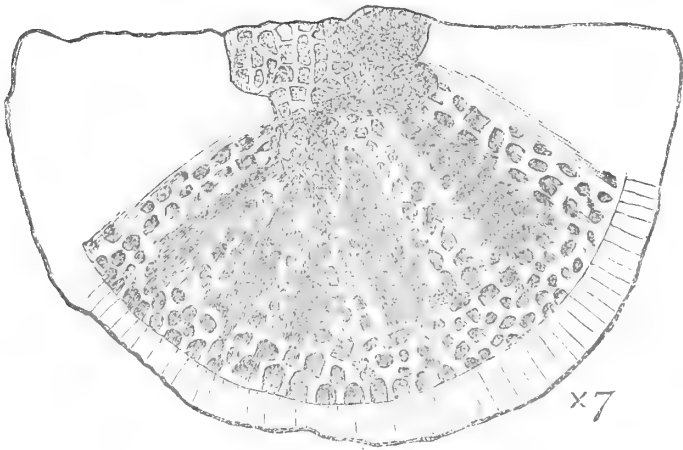

There are some less satisfactorily preserved specimens from near Napier, which are usually formed of confluent colonies, with similar structure of the central portion.

This may be the *Discoporella mediterranea* of Busk (Cat. Mar. Polyzoa, pt. iii. p. 33, pl. xxxiv. fig. 4); but this is doubtful, and it is extremely uncertain whether Busk's is the same as Blainville's and Michelin's species.

A recent specimen from Port Phillip, which I consider to be *L. echinata*, MacG. *, has the central cancelli closed by a reticulated and perforated crust; and this is also the case with some subcolonies of what I named *Radipora pustulosa* from Naples.

Attention has most been paid to the structure of the rays of *Lichenopora*; but, for purposes of classification, it seems that the central portion is the most important; and this in many cases has, at different stages, quite a different appearance, so that both young and mature specimens should be described.

This is also allied to *L. californica*, d'Orb.; but specimens from Port Western, Victoria, have the central part covered over with a *continuous* minutely perforated crust, which spreads for a short distance between the rays. We are hardly in a position at present

* *L. pristis*, MacG., seems to me to be the confluent form of *L. echinata*, MacG., and has a similar structure in the centre of the subcolonies.

to decide upon the importance of the difference between the reticulated and the merely perforated crust.

22. *LICHENOPORA BOLETIFORMIS* (d'Orb.).

Lichenopora boletiformis, Waters, Quart. Journ. Geol. Soc. vol. xl. p. 695, pl. xxxi. figs. 20, 21.

A specimen from Waikato, with the zoarium in a single layer and confluent subcolonies, and with the biserial rays much raised, surrounding a depressed central area, appears to be this species. The openings are all about the same size, mostly about 0.15 millim.

23. *LICHENOPORA HOULDSWORTHII* (Busk).

Discoporella Houldsworthii, Busk, Cat. Mar. Polyzoa, pt. iii. p. 33, pl. xxx. fig. 4.

A recent specimen from Port Western, in Miss Jelly's collection, has the "denticles" to which I referred (Bry. Naples, p. 276, pl. xxiv. fig. 11) with very distinct knobs; but the shape I cannot make out, as it would be necessary to break up the specimen. This is no doubt what Mr. Busk means by stellate pores; but the expression might have a different meaning; comparison, however, with the British-Museum specimen has established the identity.

The zoecial tubes are about 0.07 millim., and the cancelli about 0.08–0.09 millim. in diameter, with denticles in all the tubes. The fossil from Waipukurau corresponds in the size of the zoarium and in the characters.

This resembles *Radiopora Francquana* and *Unicavca collis*, d'Orb. (Pal. Fr.).

Loc. Living: Ceylon (*B.*); Port Western (Victoria). Fossil: Waipukurau.

24. *REPTOCAVEA ASPERA*, sp. nov. (Pl. XVIII. figs. 10 & 13.)

The greater part of a small oyster-shell is thinly incrustated with this species. The zoecial tubes rise but very slightly from the general surface, having the side of the peristome which is directed away from the growing edge slightly raised and acuminate; between these are small interstitial pores.

Near the border of the zoarium, and occasionally elsewhere, radial bilaminar ridges rise from the surface, with zoecia on each side corresponding to those of the basal structure. Usually, the ridges rise but very slightly (not more than 1 millimetre), though in one case a narrow foliaceous expansion rises 4 millim. above the surface and is 7 millim. wide. The minute structure resembles parts of *Lichenopora hispida*, and on that account the specific name is chosen. The growth, however, is that of *Diastopora* or *Mesenteripora*. In the interior of the zoecial and interstitial tubes there are slight elevations, which no doubt represent the well-developed "rays" of *Entalophora intricaria*, &c. There is a recent form from New Zealand, which is at any rate closely allied. This last, however, is bilaminar, the laminae being large and contorted, the colony

having originated on a *Catenicella*; in the zoecial tubes the closures are terminal with small excentric tubular projections, and the interior of the zoecial tubes has slight projections a short distance down.

D'Orbigny's generic name will serve very well to show the relationship; but I do not thereby wish to convey that we may not some day have to place it in a better-understood genus.

Loc. Waipukurau Gorge.

25. HETEROPORA PELLICULATA, Waters.

Heteropora pelliculata, Waters, Journ. R. Micr. Soc. n. ser. vol. ii. p. 390, pl. xv. figs. 1, 2, 3, 4, 7; Quart. Journ. Geol. Soc. vol. xl. p. 677, pl. xxxi. figs. 24 & 28.

Heteropora neozelanica, Busk, Journ. Linn. Soc., Zool. vol. xiv. p. 725, pl. xv. figs. 1-4; Nicholson, Ann. & Mag. Nat. Hist. ser. 5, vol. vii. 1880, p. 329.

As I have already pointed out, direct comparison has proved that *neozelanica* is only a synonym. This comparison was made with New-Zealand specimens kindly furnished by Prof. Nicholson from the same locality as Mr. Busk's. The interior was well preserved, but the exterior was corroded, and the difference in the shape of growth is not greater than in the series of Japanese specimens in the British Museum.

This may also be *H. magnifica*, Novák; but under any circumstances it will be advisable to change that name, as there is a *Multicavea magnifica*, d'Orb., which belongs to this genus.

The branches of the Napier fossil are mostly long and about 3-4 millim. in diameter; the apertures of the zoecia are about 0.12 millim., and the interstitial pores are only slightly smaller. I do not find that any of the Cretaceous or Jurassic *Heteropora*e in my collection have the apertures larger than about 0.06 millim.

The recent New-Zealand specimens have slightly larger zoecia than in the fossil, or in those from Japan.

Loc. Living: Japan; New Zealand. Fossil: near Napier and "Napier Harbour."

26. HETEROPORA NAPIERENSIS, sp. nov.

There are a number of specimens from near Napier, which I at first thought were only stout growths of *H. pelliculata*; but this does not seem to be the case, as the zoecial interstitial pores are usually about half the size of those of the fossil *H. pelliculata*, those in *H. napierensis* being only about 0.06 millim. The zoarium is sometimes formed of superposed layers, either entirely or over part of the surface, and in some there is also a tendency to slight tuberculation of the surface.

The zoarium grows from a stout base or peduncle, from which arise several (in one case 8) short thick branches (5-8 millim.), with round thickened ends, having much the appearance of some of the large calcareous seaweeds.

There are sometimes tabulæ in various positions in the zoecial tubes, but only one or two in a tube, and not many as in *H. conifera*.

This may be the *H. foraminulenta* of Novák.

Loc. Fossil: Napier and "Napier Harbour."

27. *CRISINA CANCELLATA* (Goldf.). (Pl. XVIII. figs. 8 & 11.)

Retepora cancellata, Goldfuss, Petr. Germ. p. 103, t. 36. fig. 17.

Idmonea cancellata, Reuss, Foss. Polyp. des Wiener Tert. p. 46, pl. v. figs. 25-27, pl. vi. fig. 33; Manzoni, Bri. foss. del Mioc. d'Austr. ed Ung. p. 7, pl. v. fig. 18.

Zoarium from Napier 10 millim. high and 10-25 millim. across, formed of anastomosing branches 1.5-2.5 millim. in diameter. The branches are subtriangular, that is, they have a flat surface on the front between the series of zoecia, and the dorsal surface is slightly rounded. The series consist of four or five zoecia, which are not very prominent; and on the surface between these as well as the flat part on the front, and also the dorsal surface, are numerous tubular pores, which, however, in some parts open diagonally instead of vertically. This internal structure is shown, in Manzoni's figure of *Idmonea foraminosa*, Rss. (Bri. foss. Austr. ed Ung. pt. iii. pl. iv. fig. 16 b).

A specimen from Waipukurau is decidedly smaller, with the flat space in front very narrow; so that the section is nearly triangular. At the bifurcation in this specimen there is an oecial inflation, the surface of which has large pores.

I do not consider that this can remain under *Idmonea*, and have used d'Orbigny's name of *Crisina*, a genus under which Reuss, Manzoni, and Stoliczka have placed species with a similar structure. The chief character must be considered to be the interstitial tubes between the zoecia, and in many of d'Orbigny's *Crisinae* there is a space between the two lateral series of zoecia; in *Laterocavea* and in *Semicellaria ramosa* also the structure with the small pores is similar. Possibly it might be called *Laterocavea punctata*, d'Orb. It is larger than *Crisina foraminosa*, Rss. (Septarienthon, p. 109, pl. ix. fig. 6); but it is no doubt closely allied to this as well as to *C. canaliculata*.

Loc. Fossil: Miocene of Austria and Hungary; near Napier; Waipukurau.

Since the above was written, Messrs. Pergens and Meunier have given a long list of synonyms to *Idmonea cancellata* from Faxoe (see Ann. Soc. R. Malac. de Belgique, vol. xxi. p. 214).

28. *CRASSOHORNERA WAIPUKURENSIS*, sp. nov. (Pl. XVIII. figs. 2, 3, 4, & 9.)

There are two fossils from the cutting near Waipukurau gorge, which certainly seem to be Bryozoa, and which it is best to designate for future comparison.

The one has broad thick branches, and the zoarial growth is apparently like that of *Truncatula* or *Osculipora*, with round openings

0.25 millim. wide, regularly covering the front, while the dorsal surface is sulcate, with elongate pores in the sulci. The front and back therefore correspond in structure with *Hornera*. The other specimen has the branches compressed; but the anterior and dorsal structures are the same. This grows from a small flat base.

Ceriopora arbusculum, Rss. (Foss. Polyz. Wien. Tert. p. 34, pl. v. figs. 12, 13), has much the same appearance; but from the meagre description identification is impossible.

Should more perfect specimens show that it is advisable to retain the provisional name of *Crassohornera*, the genus must be defined on more satisfactory material.

There is also a small fragment of a large branching *Entalophora* from Waipukurau. The zoecia are more or less verticillate, and there are two or more to a row, suggesting a relationship to such a form as *Peripora ligeriensis*, d'Orb.

EXPLANATION OF PLATE XVIII.

- Fig. 1. *Entalophora wanganuiensis*, sp. nov. $\times 16$.
 2, 3. *Crassohornera waipukurensis*, sp. nov. Natural size.
 4. Front of *Crassohornera waipukurensis*, sp. nov. $\times 25$.
 5. Section of recent *Entalophora intricaria*, B. $\times 37$.
 6. "Rays" of *Entalophora intricaria*, B. $\times 250$.
 7. "Rays" of *Lichenopora radiata*, Aud. $\times 750$.
 8. Front of *Crisina cancellata*, Reuss. $\times 25$.
 9. Dorsal surface of *Crassohornera waipukurensis*, sp. nov. $\times 25$.
 10. *Reptocavea aspera*, sp. nov. Natural size.
 11. Dorsal surface of *Crisina cancellata*. $\times 25$.
 12. *Tubulipora biduplicata*, sp. nov. Natural size.
 13. *Reptocavea aspera*, sp. nov. $\times 7$.
 14. *Tubulipora biduplicata*, sp. nov. $\times 7$.
 15. *Tubulipora Campicheana*, d'Orb. $\times 7$.

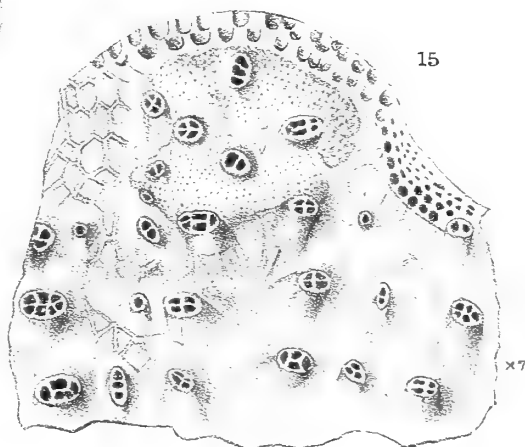
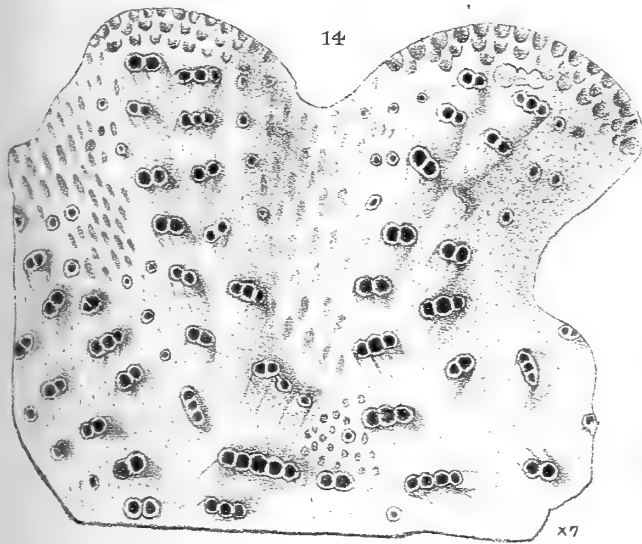
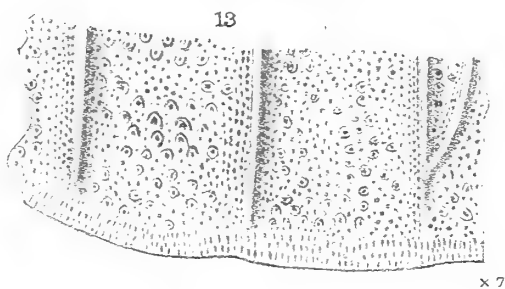
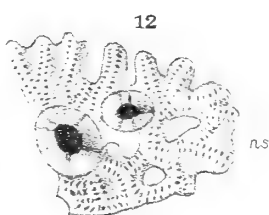
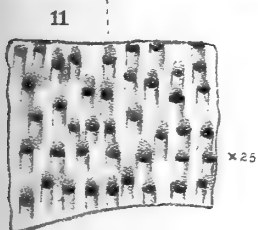
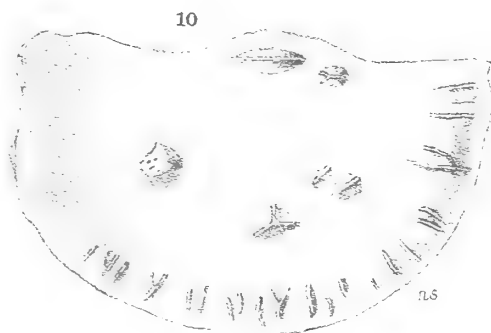
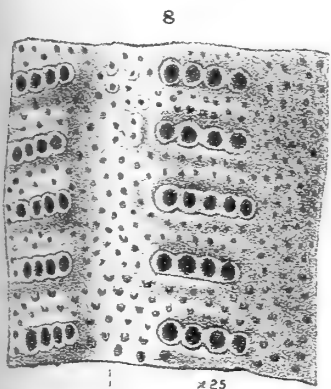
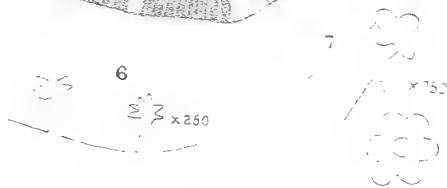
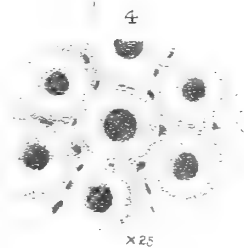
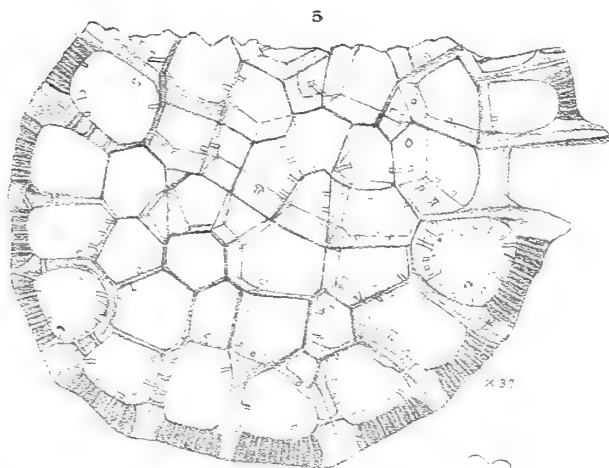
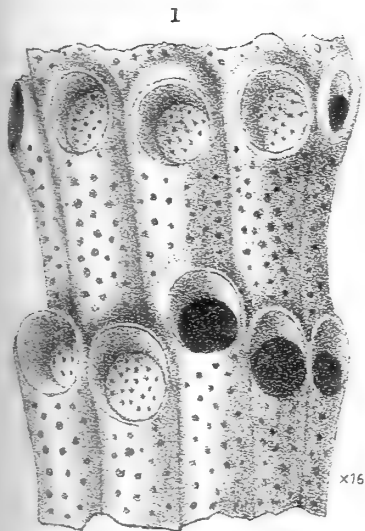

A W Waters del
A T Hollick lith.

West Newman & Co imp.

26. *On the Rocks of the ESSEX DRIFT.* By the Rev. A. W. ROWE, M.A., F.G.S. (Read May 11, 1887.)

THE rocks of the drift in Essex are of such great variety that it is very difficult to get a really representative collection ; but I have selected some two hundred specimens out of a much larger number, and these, I think, may fairly be called representative, at any rate of the rocks in the western and north-western parts of Essex. Some of these are chips from large boulders, others are rolled pebbles. I have gathered them from the surface of the land within a radius of about four miles from Felstead, taking them chiefly from the open fields, the lanes, ditches, and bye-roads, and avoiding the main roads for obvious reasons, although no imported road-metal is used in the immediate neighbourhood. A considerable number have been taken out of the Boulder-clay, and some few from the gravel-beds which underlie it. The village of Felstead stands upon high ground overlooking the valley of the Chelmer, about six miles to the north-west of Braintree and just off the highroad between Braintree and Dunmow. The general appearance of this part of Essex is that of a tableland which has been carved out into valleys, with gently sloping rounded hills. On the slopes of these hills there are at all levels, even to the very tops, beds of loamy gravel, alternating with a considerable thickness of stiff yellow loam in some parts, and in others with chalky Boulder-clay, patches of which lie on the tops of the hills and along the upper slopes, sometimes reaching down to a considerable depth, while here and there the London Clay comes to the surface. The way in which the superficial deposits lie was clearly shown a short time ago by a section which had been made in the railway-cutting near Dunmow. Unfortunately this has become covered up again ; but at the time it was made a small photograph of it was taken for me by a friend. The section showed that there were between six and seven feet of chalky Boulder-clay, part of which only was uncovered, resting upon a layer of red and yellow laminated clays, a few inches thick, overlying some twelve feet of reddish loamy gravel, consisting of large and small subangular flints, quartzites, quartz-rocks, sandstones, and lumps of hard chalk, these last being very plainly striated. Between the chalky clay and the laminated clays a large block of Jurassic limestone could be seen sticking out, and, upon examination, it was found to be deeply grooved with striæ upon more than one face. I had previously found a similar block sticking out from under the Boulder-clay, about a hundred yards away from this section in the same cutting, and this also was striated in a similar manner. But besides the numerous beds of gravel, the surface is everywhere strewn with fragments of rocks, rounded pebbles, and flintstones ; and in cutting open grips for surface-draining, or in deepening ditches and ponds, large masses of flint, rounded boulders of quartzite and sandstone, and great blocks of dolerite and other rocks are thrown

out upon the land or into the lanes, or are carted off to the farmyards to repair walls or to serve as mounting-stones, or to fill up holes in front of the doorways. And upon comparing those which I know have been taken out of the Boulder-clay with the rocks which lie upon the surface, I have found them to be, as a rule, so precisely similar in character as to leave no room for doubt that the great majority of them belong to the same series. On the other hand, there are certain fragments of rock found upon the surface whose presence there is doubtless due to other causes than the glacial drift, such as fragments of Jurassic limestone and of hard chalk rock (used in earlier times for building churches and priories), and pieces of a trachytic rock closely resembling that which the Romans imported from Germany for use as millstones. Yet, making all allowance for such fragments, there still remain the facts that an immense number of boulders and fragments, some of very large size and nearly all polished and smoothed and rounded in a remarkable manner, are found lying on the surface, which cannot conceivably have come so far from where they are found *in situ* in any other way than as having been included in the drift; and that, wherever the surface of the ground is being broken up at the present day, exactly similar boulders and fragments of rock are being dug up and left lying on the surface. These do not, however, appear to belong to the same period as the beds of gravel; for not only is the general appearance of the stones in the gravel-pits very different from the appearance of those found on the surface, but also, though quartzites, sandstones, and quartz-rocks abound both in the gravels and on the surface, yet I have not found any fragments of hard crystalline limestone or of Jurassic limestones in the gravel-beds, and only two or three fragments of dolerite, and these so decomposed that only a very small core was still crystalline; whereas, among the stones on the surface, blocks of hard crystalline limestone and of Jurassic limestone are most abundant, and there are a very great number of boulders of dolerite, some of considerable size, of which the crystalline components are as sharp and fresh as if they had just been struck off from an almost unweathered mass. The very great variety in these rocks makes it very difficult to classify them at all satisfactorily; so much so, that after having examined several hundred pieces, and having made microscopic sections of at least one hundred and fifty, I find that I can do little more than form them into groups, and point out the common features of each group, making special mention of any specimen which seems to require it.

Granite.—It is somewhat more convenient to take the igneous rocks first and to consider the sandstones and limestones afterwards. And the first group of igneous rocks should have included the granites or orthoclase-quartz-mica rocks; but though I have searched carefully for them, yet I have not been able hitherto to find a single specimen of granite. This is the more remarkable, because I understand that rocks of this class are not unfrequently found in the Boulder-clay both in Norfolk and in Lincolnshire.

Syenite.—The rocks of this class are also very rarely met with. At present I have found only two small specimens (Nos. 1, 2). Of

these, the former consists chiefly of plagioclase and hornblende, with some good examples of magnesia-mica (biotite), and is therefore an orthoclase-plagioclase syenite, and the latter is a pinkish-grey rock with not much hornblende, and that in specks. It resembles a fine-grained granite, and appears to be like the rock described by Mr. Rutley in his article "On the Igneous Rocks of the Warwickshire Coal-field" (Geol. Mag. December 1886, p. 559), though there is not much plagioclase in the section which I have taken.

Quartz-porphyrites.—These rocks seem to abound in the drift. The specimens I have are numbered 3, 5, 6, 7, 110, 111, 112, 115; the character of the last four being so difficult to determine that I had at first placed them in another group; but upon the whole they appear to belong to the porphyritic quartz-rocks. Some of these specimens are very close-grained and compact; but in others the porphyritic crystals are very distinct, and in two or three cases they are so large and abundant as to give the rock the character of a conglomerate. The ground-mass varies from a distinctly felsitic character to a mosaic of small grains. The crystals of quartz are, in some cases, mere rounded blebs; while in others they are much larger, with more or less distinct outline, though usually rounded. They are frequently cracked, and, in almost all cases, are full of minute enclosures and lines of dust. Crystals of felspar also occur full of enclosures, much worn, and so decomposed as, in some cases, to present a mealy appearance. In no. 7 there is an appearance of fluxion-structure.

Quartz-tourmaline.—Rocks of this class also seem to be very abundant. The specimens are numbered 4, 8, 9, 10, 11, 12, 108, 109, 113, 114. The ground-mass is granitic; but the grains vary very much in size. They contain schorl in abundance, either in needles enclosed in other crystals, or in aggregates of grains with a decided tendency to a fan-shaped or radiate formation, or in spheroidal patches, or else in long lines passing irregularly through the section like thin threads. One of these sections (no. 113) seems to call for special mention, as it is in many respects a remarkable rock. The specimen is part of a large rounded boulder of very great hardness, which I dug out from the gravels; it is perfectly smooth and highly polished, and has very narrow almost parallel bands of yellow alternating with narrow bands of black, so as to give it a peculiar striped appearance. The fractured surface is quite dull and very compact. The microscopic section shows a microcrystalline mosaic of quartz, alternating with numerous dark bands composed of tourmaline with dark amorphous matter.

Felsites.—Of these rocks I have found only four specimens (nos. 14, 15, 16, 17), and these are all more or less devitrified. Nos. 14 and 15 are very dark compact rocks, of sp. gr. 2.65. The section of no. 14 shows a spherulitic structure and fluxion-arrangement; but that of no. 15 is entirely spherulitic, for the spherulites press so closely upon one another as to fill up the whole space. In no. 16 there is a fairly wide band passing through the section, in which crystallites are plainly discernible in long rods, and in many cases

radiating from centres; the spherulites are more apparent in the very microcrystalline portion. But no. 17 is an entirely different rock, of a pinkish-white appearance and not close-grained: the section of this rock reveals a remarkable perlitic structure, the small narrow bands being apparently composed of minute grains of quartz; the section also contains several circular aggregates of clear felspar. I have been informed that devitrified rhyolites of this character are stated to have been found in Sweden, at Elvedalen, in Hedemarken.

Quartz-trachytes.—The only specimen that I have found of these rocks is numbered 18; the texture of the rock is fine-grained and compact, though vesicular in places; the section shows that the ground-mass is really vitreous, though so filled with minute grains of quartz as to give it an appearance of a finely granitic character; it contains some larger crystals of quartz and orthoclase with abundant enclosures and bubbles.

Felspar-porphyrites.—These rocks are exceedingly abundant in the drift; the specimens are numbered from 19 to 38. They vary very much in appearance, but in all of them the porphyritic felspar can be clearly seen in the hand-specimens, though none of the crystals are of any great size; the sections show generally a crypto-crystalline felsitic base, enclosing porphyritic crystals of orthoclase and plagioclase, but chiefly plagioclase—in some cases perfectly clear and transparent, in others in various stages of decomposition, much cracked and with outlines broken and indistinct; in some sections the felspar is altered into a mealy appearance, in others it has a pearly lustre. Augite is occasionally present in granular aggregates or in scattered crystals, and in some cases quartz. Some fine instances of zonal structure in felspar occur, notably in no. 21, and some sections contain tourmaline in abundance, especially nos. 22 to 32; this last-mentioned specimen is in many respects worthy of notice, and it is questionable whether it ought not really to be included among the quartz-tourmaline rocks. The hand-specimen is of a dark grey colour and very vesicular, the cavities being lined with minute pyramidal crystals of quartz and with minute crystals of tourmaline. In the section the porphyritic felspar seems to be made up of aggregates of minute crystalline grains corresponding with the ground-mass. The quartz is abundant, chiefly in aggregates; but one long and very clear crystal shows twinning under crossed nicols, one half remaining dark shot-grey, the other pale yellow; on rotation both extinguish partially and simultaneously; when the nicols are not crossed, the pale yellow part on rotation shows dark purplish blue changing to pale yellow, but the other half shows no colour at all. Nos. 33 and 34 are typical augite-andesites; in both the base is very vitreous and in 34 it shows great disturbance and fluxion-structure very clearly. The plagioclase is very clear, though much broken, and there are some good examples of zonal structure. The augite in 34 is, in most cases, either enclosed within the felspar, so that only a border of felspar is visible, or else attached to it, in some cases lying partly within the felspar, partly in the base; in 33 there are some good examples of a distinctly

pleochroic mineral of the enstatite group altering into bastite, the pleochroism being from pale green to brown. No. 38 contains a considerable amount of hornblende in irregular crystals, some of which is enclosed in the felspar.

Trachytes.—I have found a fair number of specimens of these rocks among the stones on the surface, but I am very doubtful whether they really belong to the drift or were imported, probably in very early times, for use as millstones; for I have found not only a curious small millstone made from this rock, but some other pieces also grooved and marked in an evidently artificial manner. A section from the millstone was kindly examined by Professor Bonney and pronounced by him to be very similar to the well-known Niedermendig rock. They are vesicular rocks of a dark grey colour approaching to black, and of a trachytic texture; the sections vary, no. 39 showing crystals of plagioclase and hornblende in a base composed of microliths of felspar and grains of hornblende. No. 40 has a vitreous base, enclosing abundant augite, but not much hornblende; in 43 the augite is again abundant and there are some fine instances of zonal structure: in all these rocks the crystals of augite and hornblende are surrounded by a distinct narrow border much lighter in colour and showing no pleochroism; under crossed nicols both crystal and border extinguish together, but in some cases appear to leave a narrow rim of light between the crystal and the border.

Dolerites.—Rocks of this class are exceedingly abundant in the drift, but they are all of a more or less fine-grained character; all the coarser dolerites and all those of a true ophitic character are remarkable for their absence. Moreover, I have not as yet found any specimens of columnar dolerites, though I understand that these rocks are of very common occurrence in the drift in the east of England; but of those which I have found, some are in very large blocks, much polished and rounded, but only a few retain any striæ: one of these blocks, which was dug up out of a ditch some few years ago and taken to the farm where it now lies, measures roughly 3 ft. × 3 ft. × 1 ft. 4 in., it is much rounded and polished and in one small part of it the striæ are very clear; another large block was lately dug from a depth of several feet in a clay-pit, in which the yellowish-white clay is full of whitened flints very plainly striated, like those numbered 173, one of which came from this clay; the block was found broken or, rather, cracked into several large fragments. The specimens of these dolerites are numbered 44 to 94, and may be divided into five groups:—The *first* group comprises nos. 44 to 52; these are of a fine-grained character and a dark greenish-grey colour, the crystals being just perceptible to the naked eye; under the microscope the texture is seen to be subophitic; they are plagioclase-augite-olivine rocks, the plagioclase being usually in microliths or else in lath-shaped crystals; the augite in aggregates or distinct crystals, in some cases rather highly coloured; the olivine varying very much, being sometimes so much altered that nothing but the outline remains the same, in other cases being very fresh and clear except along the cracks, and in some instances being in

aggregates; in nos. 47 and 52 the magnetite is in skeleton crystals; the specific gravity of these rocks varies from 2·86 to 2·90. The second group comprises nos. 53 to 60, rocks of a greyish-brown colour and fine-grained; of these no. 59 is one of the few pieces that I have found in the gravels, and no. 60 is so much altered that it is somewhat difficult to distinguish its component crystals; they are plagioclase-augite rocks, of a subophitic texture and containing no olivine; the augite is in almost all cases in granular aggregates and the plagioclase in microliths. The magnetite in some cases is in large plates and skeleton crystals enclosing augite and plagioclase; they appear to contain a little biotite; the specific gravity of these rocks varies from 2·81 to 2·93. The specimens in these two groups have a general resemblance to the subophitic dolerites of Central England, some being very suggestive of the Rowley Rag, and others of the Tideswell Dale rocks; but upon comparing them with the sections which I have made of the Rowley Rag, the Tideswell Dale rock, and the Mount Sorrell dolerite, and with Mr. Allport's sections of the Central England rocks, I could not find any such definite points of resemblance as would enable one to say with any certainty whatever that they are different parts of the same rock. On the other hand, they do not appear to have any special points of similarity with the north of England dolerites; and upon comparing them with some few sections which I have of the dolerites of Southern and Eastern Scotland and with Dr. A. Geikie's description of these rocks in the Transactions of the Royal Society of Edinburgh, I could not discern any real points of resemblance. They may be found to be identical with some of the Scandinavian dolerites, but they are altogether different from the few specimens of those rocks which were sent me from Sweden.

The third group of dolerites, nos. 61 to 83, includes some remarkable specimens of plagioclase-augite-olivine rocks of trachytic texture, the magma in some cases being exceedingly vitreous. These are all very black-looking close-grained rocks, the crystals not being discernible with the naked eye, except the olivine: one of these, no. 69, is from the gravel; but the specimen was so decomposed that it was only from the core of it that a good crystalline section could be obtained. The magma of these rocks is vitreous, the plagioclase generally in minute microliths and, as a rule, not abundant, in some few cases in granular aggregates, but generally in well-formed crystals, sometimes porphyritically developed and of a fairly dark colour; the olivine usually porphyritic, in some cases remarkably clear and fresh, but occasionally altered, and in a few instances it is in granular aggregates. The magnetite is often in minute rounded grains, as if the section had been powdered with it; in some cases it partially or completely fills up crystals of olivine, and in a few sections it has a linear arrangement. The specific gravity of these rocks varies from 2·90 to 3·02. So far as I have been able to judge, these dolerites have neither any general nor any special likeness to the dolerites of Central England, except perhaps in these two respects, viz. that in nos. 76, 80, 81, the olivine is in granular aggregates, which, I think, is somewhat unusual, although I believe it occurs in some specimens

from the Rowley Rag; and that nos. 64, 65, 66 have some points of resemblance to a rock from Swinnerton Park and to a boulder found near Leicester which resembles that rock; but they differ in one most important point, viz. that nos. 64, 65, 66 contain porphyritic augite, remarkably well developed, whereas I understand that neither the Swinnerton-Park basalt nor the Leicester boulder contain porphyritic augite at all. These dolerites, moreover, are totally unlike any of the known dolerites of the north of England; they are, however, remarkably similar to some Scandinavian rocks, and this is especially so in the case of those very specimens, no. 64, 65, 66, which differ from the Central England rocks, and in that very point in which they so differ, viz. in their containing porphyritic augite; for upon comparing them with some specimens sent me from Sweden and labelled Pilahall (Scanie), Gustafsborg (Scanie), and Anneklef (Scanie), the general similarity between them is in itself striking; and besides this the sections show that they are almost identical in the following points:—the clearness of the olivine, the porphyritic development and sharpness of outline of the augite, the peculiar greenish appearance in the centre of many of the crystals of augite, the powdered arrangement of the magnetite, and the specific gravity 2.9.

The fourth group of dolerites, nos. 84 to 91, includes some rocks of considerable interest. They are of a dark grey colour, as a rule very close-grained, some being less so and lighter in colour; they are plagioclase-augite rocks of a subophitic texture; the plagioclase is usually in microliths and the augite in granular aggregates, though in 88 and 89 it is in distinct crystals with fine examples of twinning bands; these specimens are so remarkably like the rocks of the Whin Sill as almost to establish an identity, for not only is there a very great general likeness in the hand-specimens, but the sections show that they are identical in several points: (1) the sections of the drift-rocks contain white colourless augite in long prisms, (2) they have some fine examples of a distinctly pleochroic mineral of the enstatite group (hypersthene?) altering into bastite, (3) they have many small grains of biotite scattered throughout the sections, and (4) the specific gravity of nos. 86 and 88 is 2.93. Upon referring to Mr. Teall's article upon the Whin Sill (in *Quart. Journ. Geol. Soc.* vol. xl. No. 160) it will be seen that the first three points are special peculiarities of this rock, and that in three out of the six specimens mentioned the specific gravity is 2.94. I understand, however, that in Central Scotland there are rocks allied to the Whin Sill, and that the Hunneberg rocks in Scandinavia have been shown to be very similar to these rocks; the two specimens from the Hunneberg which I have are of a totally different character, so much so that there is not even a general likeness between them and the specimen which I have of the Whin Sill.

The fifth group contains three specimens, nos. 92, 93, 94, each of which seems to call for special mention. No. 92 is a piece of an exceedingly hard boulder of dolerite, measuring about a foot each way; the boulder is completely rounded and polished, but scarcely

at all weathered; the section shows it to be an ophitic hypersthene-bearing dolerite, this being the only really ophitic dolerite that I have found in the drift: the plagioclase is abundant, but much of it is very cloudy; the augite fairly abundant, much cracked and broken; there are several very good examples of hypersthene both in grains and in distinct crystals, with the pleochroism from pale watery green to orange or brownish red fairly strong; some of the crystals are much cracked and some almost filled up with dark yellowish-brown alteration-matter; in one or two cases a fibrous structure has been developed. No. 93 is a remarkable rock, if it be a genuine rock specimen and not a slag; it has all the appearance of a slag, being very black and vesicular, and the magnetite is the great feature of the rock; but it is also composed of crystals which polarize in bright colours, have some distinct outline, extinguish on rotation, though not simultaneously, and have some appearance of cleavage; its specific gravity is 4.51. The remaining specimen, no. 94, is a plagioclase-augite rock of trachytic texture, of which the plagioclase is the great feature; for not only is it in abundant microliths with remarkably distinct fluxional arrangement, but some larger crystals are enclosed, which are of anterior consolidation to the ground-mass; the section reveals a structure evidently very similar to that of which Professor Judd speaks in his article on the volcanic rocks of the north-east of Fife (Quart. Journ. Geol. Soc. vol. xl. p. 428), where he says, "the minerals of the second consolidation consist of imperfectly developed microlites of felspar . . . the glassy base contains numerous trichites . . . the disposition of these and the felspar microlites of the second consolidation with respect to the larger porphyritic crystals reveals a most striking flow-structure: not only are these minuter elements of the rock arranged in irregular parallel bands, but they are crowded in front and along the sides of the porphyritic crystals, trailing off behind them."

Granulites.—As these rocks are classed by some authors with the eruptive rocks, and by others with the metamorphic rocks, I have placed them here between the dolerites and the crystalline schists. The only two examples which I have, nos. 95, 96, appear to be specimens of the same rock, although found at different times and in different localities. The rock is of a dark grey colour, of a holocrystalline granular texture, and of a slightly schistose structure; the sections show that the rock contains plagioclase and orthoclase in abundance, but chiefly the former, the crystals showing signs of considerable strain, for they are much broken and bent, and other crystals appear to have been forced between the broken parts; the hornblende is in granules, and there is much secondary hornblende in cracks passing through the sections, and in some cases through separate crystals, dividing them but not apparently displacing the parts; the rock also contains hypersthene in abundance, in grains and crystals, and some biotite. Mr. Teall kindly examined the sections for me, and he writes me that they are very interesting rocks belonging to a well-characterized type.

Similar rocks occur in Saxony, where they are known as pyroxene-granulites, in Sweden (hyperite of Tornebohm), in Minnesota (augite-diorite of Streng), near Baltimore (gabbro or hypersthene-gabbro of Williams), and in Scotland, where they have not been described. The original minerals appear to have been augite, hypersthene, magnetite, and plagioclase; the plagioclase of the Baltimore rocks is bytownite; in most districts where they occur they show a considerable amount of variability in their mineralogical composition; felspar is sometimes abundant, sometimes absent; secondary hornblende is frequently present, and sometimes it entirely replaces both the pyroxenes*.

Crystalline Schists.—These rocks are not abundant in the drift. The specimens are numbered 97 to 105 with 171 and 180. Of these 97 to 103 and 180 are hornblende-schists, and are of a greyish-green colour and close-grained. In some cases they are evenly foliated and split with a very level fracture; in others they are very hard and much contorted, as in no. 100, a section which was taken from a large boulder, exceedingly hard, though rounded and polished. The sections show orthoclase, as a rule, cloudy and much altered, quartz not in any great quantity, and hornblende varying considerably. In nos. 97 and 99 it is in long prisms (actinolite), in 87 it is in irregular grains and prisms with good examples of transverse and longitudinal sections and with some instances of twinning. In 101, 102 it is not nearly so abundant, but in 103 it is most abundant in grains and prisms so minute that the hand-specimen shows a very compact structure of a silky appearance in which it is hardly possible to detect the separate crystals. But no. 98 is the most interesting of these sections: for besides the hornblende and some irregular grains of a colourless mineral showing weak tints under crossed nicols (zoisite?), it also contains abundance of dark blue tourmaline (indicolite), the prisms sometimes showing a tendency to gather into radiate or fan-shaped groups. The fact of the occurrence of tourmaline in this rock, when considered in connexion with the number of quartz-tourmaline rocks in the drift, makes it at any rate probable that they have come from the same locality, viz. from some locality where tourmaline-bearing granite is intrusive in hornblende-schists. Nos. 104, 105, and 171 are mica-schists, 104 being granatiferous; this section was from a block of considerable size, and the garnets are fairly abundant, though much cracked and broken.

Quartzites and Quartz-Rocks.—These rocks are most abundant in the drift; the quartzites occur in very large boulders as well as in numberless rolled pebbles. Sometimes they are very clearly banded, but in most cases they show no signs of banding. They are usually very fine close-grained rocks with a highly lustrous fracture. Quartz-rocks occur mostly as large, rounded, and highly polished boulders, often, especially in smaller pebbles, of a rose-red colour. The only specimens I have of these rocks are

* Lehmann "Die Entstehung der aekrystallinische Gesteine." Streng. Neues Jahrbuch, 1877. Williams, Bull. U. S. Geol. Survey, no. 28, 1880.

numbered 106, 107, 172, and of these the section of 107 is full of dark lines, apparently lines of fine dust, crossing and recrossing the crystals.

Silicified Wood.—Some few specimens of silicified wood occur in the drift; those I have are numbered 116, 117, 174; of these 116 was kindly examined for me by Prof. Williamson, of Victoria University, and he considered it to be coniferous and probably Jurassic; 117 is a section of a much larger fragment, and shows very clearly the medullary rays, separated by interlacing woody fibre.

Sandstones.—These occur in much greater abundance in the drift than any other rock except the flint. The specimens which I have selected are numbered 118 to 140 and have been for the most part struck off large blocks much rounded and polished. Some of these blocks are very large, one measuring 5 ft. 9 in. \times 3 ft. 6 in. \times 2 ft., and as this lies deeply imbedded in the soft clay ground, it must be nearly 4 ft. 6 in. in width. This mass was dug out some few years ago and dragged to its present position, where it forms part of a farmyard wall within a mile of Felstead; the specimen is numbered 132. In the village of Felstead there is a raised way, the outside border of which is formed of no less than thirty-six large blocks of sandstone, two of limestone, and one of dolerite; others stand near farmhouses and blacksmiths' forges and in front of inns. The majority of them are ferruginous, some being highly so: a fair number are completely siliceous; as a rule they are very fine-grained, some being specially compact and none that I have found being really coarse. They are also, with two or three exceptions, entirely unfossiliferous. I am indebted to Mr. H. Keeping, of the Woodwardian Museum at Cambridge, for having examined them, and he considered them to be for the most part Carboniferous Sandstones, two or three being pebbles of Millstone Grit; the exceptions, which are fossiliferous, are first a block of hard and compact reddish-yellow sandstone, no. 128, containing casts of *Aviculopecten* and some small fragments of crinoid stems; and next two large blocks of a greyish-yellow sandstone, no. 123, one measuring 3 ft. 3 in. \times 2 ft. 6 in. \times 1 ft. 5 in. One of these forms part of the raised way in the village, and consequently I cannot do more than just chip it. The other and larger block lies in a farmyard, and I have therefore been able to examine it; I have found in it fragments, but only fragments, of *Pecten orbicularis*; this sandstone has, however, a peculiar glazed surface when fractured, and Mr. Keeping recognized it as being of the same character as that which occurs in the Lower Greensand in Lincolnshire, and which he has described and figured in his paper on the Lincolnshire Neocomian (Quart. Journ. Geol. Soc. vol. xxxviii.). I have also found two or three smaller boulders of a glauconite sandstone, which probably belongs to the same series. In addition to these, there are here and there boulders of a rather soft argillaceous sandstone, but, so far as I have yet discovered, these are quite unfossiliferous; and boulders of the coarse conglomerate known as "Hertfordshire Puddingstone" are fairly abundant, some of them

being of considerable size. In connexion with the sandstones, it may perhaps be worth mentioning that an implement made from very hard sandstone was found on the surface close by Felstead, and brought to me by the gentleman who found it. It is, I believe, a Palæolithic implement, of a shape rarely found in England, and may have been lying in the clay; this seems the more likely from my having found two small implements and two abraded quartzite pebbles in the clay-pit mentioned above. They were taken out of a yellowish-white clay full of striated flints and resting on chalky Boulder-clay.

Limestones.—These are also found in considerable abundance in the drift; the specimens nos. 141–169 belong to the Carboniferous, Triassic, Jurassic, and Cretaceous series. Of the Carboniferous, there are boulders and fragments of all sizes, some being of considerable size, for one measures 2 ft. 3 in. \times 2 ft. \times 1 ft. 3 in., and another 2 ft. \times 1 ft. 6 in. \times 1 ft. They have become weathered to a light bluish grey and are smoothed and rounded, but I have not detected any striation. They are of a highly crystalline character, dark grey in colour, hard, and fine-grained. The sections under the microscope show some very perfect examples of *Valvulina*, *Endothyra*, *Trochammina*, &c., chiefly *V. bulloides*, *V. Youngi*, *E. Bowmani*, and *T. incerta*, and in some of the sections the rhombohedral plates of calcite are very perfect. In addition to these, there is one small piece containing *Lithostrotion* (no. 160). Of the Triassic limestone there are two pieces from the Rhætic beds, nos. 162, 163, containing very good specimens of *Pleuromya crowcombeia*; one of these was taken from a railway-cutting at Castle Hedingham, considerably beyond my radius, the other I found near Felstead; I am indebted to Mr. H. Keeping for identifying them. They are somewhat interesting, because though I see that the Rhætic beds are said “to extend as a continuous, though very thin band at the top of the Trias, from the coast of Yorkshire across England to Lyme Regis on the Dorsetshire shore” (‘Textbook of Geology,’ A. Geikie, p. 766), yet I understand that no Rhætic beds come to the surface anywhere in the north of England, and in that case these must be remnants of a very early denudation. Of the Jurassic series, there is a great abundance of blocks of all sizes, but I have taken only a few specimens, of which one or two are from the Cornbrash, and the majority from the Oxford Clay and the Kimmeridge Clay, containing *Cardium*, *Trigonia clavellata*, *Ammonites serratus*, &c. There are also two or three pieces of Purbeck Marble, containing *Puludina fluviorum*; but inasmuch as this rock was much used for church-building and building of priories &c., I feel that all of it that is not actually taken out of the Boulder-clay must be looked upon with suspicion, and this will necessarily apply to many of the Jurassic fragments besides the Purbeck. Of the Cretaceous series, I have found one or two blocks of glauconitic limestone of some size, one in particular, measuring 3 ft. \times 2 ft. 6 in. \times 2 ft., which lies in an inn-yard in Felstead, and is very much weathered and worn; the section is numbered

152. Besides these, many lumps of hard chalk occur in the drift, some of them as rounded boulders with distinct striation. No. 169 is a section of this hard chalk, and is full of circular organisms of which little but the form can be detected. Mr. Keeping identified a specimen as being exactly similar to the hard chalk of Cambridgeshire. There remain only the flints and the Boulder-clay itself to be considered. The flints are by far the most abundant of the rocks in the drift, and sometimes are in blocks of very considerable size; two great blocks which were dug out of the Boulder-clay in making a very deep drain measure respectively 22 in. \times 11 in., and 19 in. \times 11 \times 7 in. In examining some Boulder-clay within two miles of Felstead in a disused clay-pit, I dug out several large flints, which were so highly polished on all sides that the surface was quite transparent; there were a great number of them lying in this clay at a depth of from four to five feet from the surface; but though apparently whole as they lay, yet, when taken out, they were all without exception found to be sharply cracked in one or two places without being at all splintered, and the clay itself was quite undisturbed. Of the chalky Boulder-clay itself three slides will be found numbered 170; they were taken from a mass of this clay exposed in an open grip close to Felstead, and they contain great numbers of very minute Foraminifera, many of them in perfect preservation, mixed up with particles of quartz-sand.

I fear that this investigation into the character of the rocks of the Essex drift has so far been productive of little, if any, practical result; but it is possible that the mere description of the rocks may lead to some important results as regards the general question of the glacial drift. In taking it up, I hoped to discover some of the localities from which the different rocks had come, and it is possible that further investigation may be productive of more definite results; but at present I feel that the difficulties of actually identifying these fragments with the rocks of any special locality are so great that I am not myself capable of coming to any definite conclusion upon such a question. I have to thank Professor Bonney and Mr. J. J. H. Teall for so kindly examining many of the specimens and sections, and for several valuable suggestions. My thanks are also due to Professor A. Geikie and Mr. Clement Reid for kindly inspecting the specimens, and to Mr. H. Keeping for identifying several of the sandstones and the fossils in the limestones.

DISCUSSION.

The PRESIDENT said the author of the paper had shown how much might be done by a petrologist even in so unpromising a region as Essex. Most geologists had experienced the difficulty of identifying rocks transported from a distance. Unless, however, the fragments are actually found *in situ* in the Boulder-clay, it is well to beware of concluding that they have not been brought to the spot. He related a case in which a Mexican carving was picked up in a Roman encampment in Devonshire.

Mr. WHITAKER said it was only by continual endeavours to identify the rocks of the Boulder-clay that any knowledge of their original derivation could be obtained. He also noticed the number of foreign fragments scattered over the country artificially. The sandstone, which he concurred with Mr. Rowe in regarding as Neocomian, was one of the commonest stones of the Boulder-clay in West Norfolk, but he had tried in vain to ascertain its origin. The paucity of granites was common in the Drift of the eastern counties, but the occurrence of Rhætic stone was new to him. On the Cromer coast there were boulders of rocks similar to those on the table, and many of the Cromer blocks were of Norwegian origin.

Mr. COLE mentioned the numerous pebbles of igneous rocks in the Bunter pebble-beds, and thought that their transference to the drift might complicate the question of the origin of the materials.

The PRESIDENT pointed out that Niedermendig beds were worked for mill-stones by the Romans, and fragments occurred all over Europe. The sandstone with glistening fractured surface was from the Spilsby Beds of Southern Lincolnshire, as shown by a fossil it contained.

Mr. ROWE said his specimens were from large boulders, and nearly all had been found in the Boulder-clay itself or could be traced to it.

27. *On the ORIGIN of DRY CHALK VALLEYS and of COOMBE ROCK* *.

By CLEMENT REID, Esq., F.G.S. (Read February 23, 1887.)

FOR many years the singular mass of angular flints and Chalk, known as the Brighton Elephant-bed, has been familiar to geologists †. This deposit I had not seen till 1884, when I was instructed to examine, for the Geological Survey, the Pleistocene deposits of Sussex between the escarpment of the South Downs and the sea.

Coming from eight years' work in strongly glaciated districts, I was at once struck by the appearance of the Elephant-bed—or, as it is called in the district, the "Coombe Rock." It is a very different deposit from anything commonly seen in the Yorkshire or Lincolnshire Wolds, and different, though not so markedly different, from anything found in Norfolk.

This occurrence in a non-glaciated district of a type of gravel unlike anything of ordinary occurrence in glaciated districts of similar configuration aroused my interest. After two years' study of the beds in the field, I venture to bring forward my views as to the mode of formation of Coombe Rock and as to the origin of dry Chalk Valleys—two subjects intimately connected.

The configuration of the surface beneath the drift on the seaward side of the South Downs is identical with that found in the Chalk districts of Yorkshire and Lincolnshire. In each of these districts we have a dip-slope from the edge of the escarpment seaward. But this slope does not pass under the low-lying drift areas; it ends abruptly in a cliff, now much degraded, but still recognizable as a sea-cliff both by the marine deposits banked against it and by its independence of the line of strike. This cliff is well seen at Black Rock, near Brighton, and passes also through Goodwood Park.

The result of this ancient marine erosion is, that we have in the South Downs a moderate southern slope from the escarpment, then a sudden drop at the partially buried cliff, and then a plain sloping very gently seaward.

It is needless to say more about this period of marine erosion, for the structure described is not directly connected with the subject of this paper. It is important, however, to realize the general contour of the country before the Coombe Rock was deposited, or one cannot understand the distribution of this later gravel.

Subsequent to the formation of the ancient sea-cliff an enormous mass of angular flint and chalk detritus was swept from the Downs, and spread far and wide in a continuous sheet over the low lands.

* The facts obtained during the work of the Geological Survey are communicated by permission of the Director General.

† See Mantell, 'Geology of Sussex,' 1822, p. 277.

This deposit seldom extends far up the valleys, but it can be traced as much as eight miles south of the old cliff, over a surface of Chalk, Eocene, and marine Pleistocene beds.

The Coombe Rock, though of singularly uniform character considering its coarseness, changes as the distance from the Downs increases. In the Coombes, and for three or four miles south of the Downs, it consists of a mass of unstratified, or obscurely stratified, flints, battered, but not rolled, and imbedded in a matrix of chalky paste and pieces of chalk. Close to the old cliff, as at Brighton, large masses of chalk are found in it, and also, locally, numerous greywethers. Pebbles only occur in places where they might be obtained from older beds immediately to the north.

As the distance from the old cliff increases, the Coombe Rock changes laterally into a deposit known locally as "shrave." This consists of angular flints in a loamy matrix, the proportions being such that the mixture is worthless either for gravel or brick-earth. Still further from the Chalk, as at Selsey, the shrave changes into almost clean brick-earth, though it still contains scattered angular flints. Thin brick-earth also overlies a considerable portion of the Coombe Rock around Brighton and Worthing.

The fossils of the Coombe Rock consist almost entirely of teeth of Horse and Elephant, broken, and apparently also decayed, before they were imbedded. A few Palæolithic implements have also occurred. Though careful search was made I could not find a single mollusk, nor any plant-remains, except two or three pieces of decayed wood.

It seems evident, from the peculiar character of the Coombe Rock, that it was not formed by agents now at work in the district. It is not of glacial origin, for none of the stones are striated, and the few from distant sources are such as we know occur in the underlying marine Pleistocene deposit. It is not marine, for it is almost unstratified, the stones are not rolled, and the marly matrix contains no shells, though full of undissolved chalk. It cannot be a gravel formed by ordinary fluvial action, for there are no valleys to contain the streams, and no river transports soft chalk-detritus more than a short distance, or lays down sheets of gravel of this singularly unworn and unstratified character.

The enormous sheet of Coombe Rock just described has evidently been derived from the Downs, and I believe that a study of the contours of the Downs gives us the key to its mode of formation.

The peculiar rolling outline of our Chalk Downs, the steep-sided valleys winding for miles among the hills, yet never, even in the wettest season, containing a drop of water, are familiar types of English scenery. But, perhaps because so familiar, it does not at first strike one that these outlines point to conditions which have now entirely passed away. No streams now fill these upland valleys, and where streams do occupy the bottoms of Coombes, their beds fall very gently, so that they do not assume the character of mountain-torrents, as any stream in the steeper Coombes must necessarily do. It is impossible, under present conditions, for any stream to exist

in these dry valleys ; for the Chalk is so porous that the heaviest rain sinks in directly, and the most continued rainfall merely causes new springs to burst out at some point rather higher up the valley than

Fig. 1.—*Contour-map of a portion of the South Downs between the Valley of the Adur and the Devil's Dyke. (Scale 1 inch to 1 mile.)*

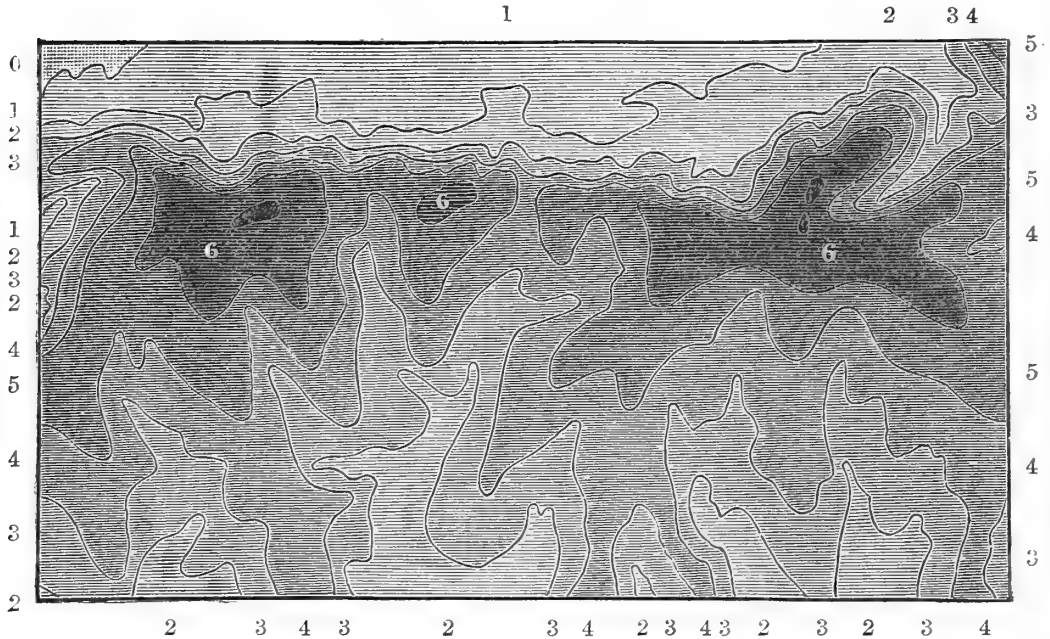

Explanation of tints.

0=1'-100'. 1=100'-200'. 2=200'-300'. 3=300'-400'. 4=400'-500'.
5=500'-600'. 6=600'-700'. 7 (black)=700'-800'.

usual. The upper and steeper portion of the valley still remains perfectly dry, and no running water can be found where the incline of the bottom of the valley exceeds the slope of the plane of saturation in the chalk. This is well shown in the Downs near Brighton (see fig. 1).

This difficulty in accounting for the erosion of dry Chalk Valleys by running water has been felt by other geologists, who have tried to overcome it by an appeal to a former submergence and consequent rise in the level of the plane of saturation ; or to a former higher level of the plane of saturation before the valleys had been cut to their present depth * ; or, thirdly, to an enormous increase in the rainfall †.

None of the explanations seem sufficient, though perhaps each of these agencies has to some extent assisted in the denudation of the lower portion of the valleys.

There is no evidence of a submergence while these Coombes were

* Prof. Prestwich, Presidential Address, 1872, pp. 58-63 ; and Dr. J. Evans, Presidential Address, 1875, p. 37.

† A. Tylor, "Action of Denuding Agencies," *Geol. Mag.* dec. ii. vol. ii. pp. 437-476. See also Prof. Prestwich, "On a peculiar bed of Angular Drift on the Lower-Chalk high Plain between Upton and Chilton," *Quart. Journ. Geol. Soc.* vol. xxxviii.

Fig. 2.—Sections of dry Thalle Coombes in the South Downs. (Scale 4 inches=1 mile.)

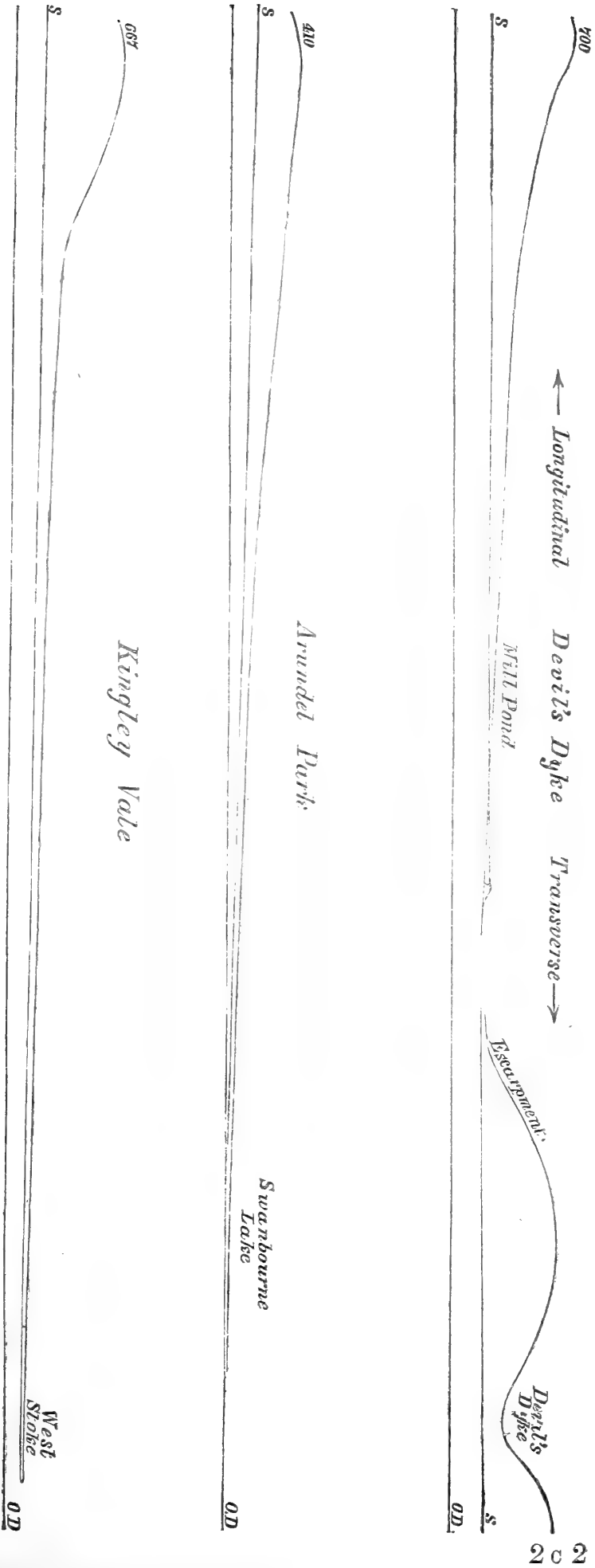

s=plane of saturation, drawn with a rise of 60 feet in the mile.

O.D. Ordnance Datum.

202

being eroded. In fact the descent of Coombes near Rottingdean to the sea-level, and the way that other Coombes plunge beneath the tidal marshes of the Adur and Arun, are strongly suggestive of a slight elevation while the erosion was taking place.

Prof. Prestwich's view that the deep trenching of the Downs by valleys has gradually lowered the plane of saturation and dried the Coombes, is clearly applicable to a large number of the slightly inclined Coombes like those through which the two lines of rail pass near Brighton. But the whole structure of the country, the proximity of the escarpment on the north, of the old sea-cliff on the south, and of the deep valleys of the Wealden rivers, which traverse the Downs from north to south, shows clearly that the outlet for the water must have been just as free then as now, so far as deep trenching could aid it. All these features existed before most of the Coombes were cut or the Coombe Rock deposited. The greater depth to which the Coombes have now been cut can be left out of account; for dry Chalk valleys play no part in the present superficial drainage, and it would make little, if any, difference in the height of the plane of saturation if they were filled up again.

The trenching cannot therefore affect the steeper Coombes, where the water-level is hundreds of feet below the surface and the incline very great. The slope of the plane of saturation in Chalk never exceeds, if it reaches, 60 feet in a mile; here we are dealing with slopes seldom less than 100 feet, and in several instances reaching 500 feet in the mile. To illustrate this, I have drawn on a true scale sections of the three Coombes in the South Downs, which are most generally visited (fig. 2).

No change could cause springs to break out in the upper portion of these valleys, unless it were a deep submergence of the whole of the adjoining low lands. If such upland springs had formerly existed, their successive failure through the gradual lowering of the plane of saturation would necessarily have left evidence in extensive deposits of rolled gravel. Winding terraces would also border the Coombes at various heights, like the terraces round the Scottish or Norwegian fiords. The low lands ought also to yield abundant evidence of a submergence of 100 fathoms, whether under sea or fresh water.

Nothing of the sort occurs, and one of the most striking characteristics of these dry Chalk valleys is the almost entire absence in them of gravel and the absence also of definite terraces. If terraces formerly existed they ought still to be found; for when once left dry they would be out of reach of running water, and might be preserved for an indefinite time.

There is another difficulty which prevents us from accepting either of the above-mentioned theories. Nearly all the valleys traverse the whole breadth of the Downs, and then end abruptly just before the escarpment is reached. If these valleys had been gradually cut back by springs, many of them ought to fall northward to the escarpment, where most of the large springs are found; but nearly all the Chalk Coombes follow the general slope of the ground and open to the south.

Of the effects of the hypothetical "Pluvial Period" I have nowhere been able to find any trace in the Coombe Rock. One would expect such a period to be characterized by a prolific aquatic fauna and flora. But instead of this, nearly all the Pleistocene freshwater deposits I have been able to examine show a remarkable paucity of purely aquatic forms and a considerable development of amphibious species, such as can survive for a long time buried in mud.

Again, a Pluvial Period would enormously swell the rivers, which would cut deeper and wider channels, transport more gravel, and wear the stones more. Though we find abundance of deep channels cut through the Downs, the most marked peculiarities of the Coombe Rock are that it spreads mainly in broad nearly level sheets, has been almost entirely swept out of the valleys, and is yet very little worn.

The peat-deposits, such as a Pluvial Period ought also to have left abundantly interbedded in its alluvia, are entirely absent from the Coombe Rock. It has been a great disappointment to me to be unable to obtain any plant-remains except a few pieces of decayed pine-wood, possibly derived from an older deposit.

From what has just been pointed out, it seems that none of the theories usually accepted is sufficient to account both for the origin of the Coombes and for the transport of the Coombe Rock.

Coombes are not forming now—in fact, many are so steep and narrow that they are gradually filling up from the chalk and dirt rubble which rolls down the slopes, dislodged by the sheep. Coombe Rock also is not now being formed. The gravels of the Lavant and other chalk-streams are of a totally different character, and the rainwash and talus now accumulating at the foot of steep slopes are also different.

As no denuding agent now at work in the south of England seems sufficiently energetic to account for the transport of this mass of rubble, and similar deposits are not well represented in glaciated districts, it was at first very difficult to explain its origin.

However, we know from the evidence of fossils that during some part of the Pleistocene Period a thoroughly Arctic fauna and flora lived in the south of England. At Fisherton, near Salisbury, in beds that seem to correspond with the brick-earths associated with the Coombe Rock, we find many species of high northern mammals*. At Bovey Tracey, associated with the "Head" (a deposit very like Coombe Rock), the Arctic birch, bearberry, and some northern willows occur. In Central France the Reindeer is abundant.

Judging from the northern character of the fauna and flora, the mean temperature of North-western Europe at this period cannot have been less than 20° lower than it is now, probably it was about 30° lower. This would give a mean temperature in the south of England very considerably below the freezing-point; consequently all rocks not protected by snow would be permanently frozen to a depth of several hundred feet.

* Stevens, 'Flint Chips,' pp. 12-30.

This would modify the entire system of drainage of the country in a way that I do not think has been realized. All rocks would be equally and entirely impervious to water, and all springs would fail. While these conditions lasted, any rain falling in the summer would be unable to penetrate more than a few inches. Instead of sinking into the Chalk, or other pervious rock, and being slowly given out in springs, the whole rainfall would immediately run off any steep slopes like those of the Downs, and form violent and transitory mountain-torrents. These would tear up a layer of rubble previously loosened by the frost and unprotected by vegetation. The material carried away would not have the Chalk washed or dissolved out, for a single flood of this description could have little solvent power, and much of the Chalk might not be thoroughly thawed*.

Each of these floods would have an enormous scouring and transporting power; for the fall in the valleys is very great. It is noticeable that no Coombe Rock is found in valleys that have a greater slope than 100 feet in the mile, and that the main mass is deposited south of the Downs, where the slope is much less. Probably the further transport across the low lands of the unworn flints scattered through the brick-earth was greatly assisted by "anchor ice."

On the flat lands any small channels formed by one summer's floods would be filled with ice and frozen gravel next winter, so that subsequent floods would have to cut fresh channels over the plain. This would lead to the formation of flat subaerial deltas, which advanced seaward and became confluent over the whole plain between the old cliff and the sea. Chichester stands on one of these old deltas, which consists of chalky Coombe Rock for $4\frac{1}{2}$ miles from the Downs and slopes about 30 feet in a mile; the loamy southward continuation is, of course, very much flatter.

The constant excavation of new channels, while these conditions lasted, is probably the cause also of much of the apparently un-systematic grooving so commonly found in rocks underlying gravels of this type; a frozen gravel is just as hard as, or probably harder than, frozen chalk.

This, I believe, was the origin of our steep-sided Coombes and of the Coombe Rock. There is no need of any excessive rainfall; in fact the apparent deficiency of snow during this cold period, combined with the remarkably Arctic character of the fauna of Fisherton, makes it probable that it was a period of drought, perhaps equivalent to the Löss period in Central Europe.

A recognition that physical conditions of this peculiar type held in non-glaciated parts of England during the glaciation of other parts seems necessary to a more perfect understanding of the origin of our Pleistocene deposits. In the Arctic regions, beyond the

* The erosive power of rain falling on porous beds before they are thawed has been incidentally alluded to by several writers; but apparently this permanent freezing of the rocks and consequent stoppage of all underground circulation in the south of England has not been taken into account.

limit of the ice, such a frozen belt is always found. It may be observed, however, that the frozen lands of Siberia and North America are either lowlying or have been much glaciated. Continued glaciation and denudation have destroyed most of the bolder features; we therefore do not commonly find steep hills of soft rocks, like those that were so rapidly denuded in England.

In the south of England denudation during the continuation of these conditions seems to have been enormous and extremely rapid. If the time had not been short, all soft rocks would soon have been planed down to one gently undulating surface, like the plains of Russia and Siberia.

It is not here necessary to try to correlate the Coombe Rock with any particular Glacial deposit of other parts of England. All that I have attempted to show in this paper is, that a certain *type* of denudation must necessarily have acted in the frozen lands, bare of snow, during some part of the Pleistocene Period. Tundra-conditions may have recurred several times. Probably some of the so-called "Interglacial Deposits" of the north merely show a deficient snowfall and consequent change to these conditions. An actual amelioration of the climate need not have taken place. However, the further consideration of these points must remain for future work.

DISCUSSION.

The PRESIDENT observed that whatever difference of opinion there might be as to the subject of the origin of dry valleys in the Chalk, it was one which would always excite the interest of those who lived amongst them.

Prof. SEELEY stated that Canon Gover had long studied the dry valleys of this part of the South Downs, and had come to the conclusion that in their upper portions they were excavated by glacial ice, and in their lower parts by the action of running water. Last Easter he went over the evidence with Canon Gover and examined in detail the Findon valley and adjacent districts; but he failed to find any proof that ice had played an important part in relation to their formation. On the contrary, all the facts seemed to show that these valleys were in the main the work of the sea, during a time of comparatively rapid change of level of the land. The valleys run up inland from the inland cliff of chalk, as they might be expected to do if they were formed by erosion along lines of jointing. It was manifest that the valleys had formerly been filled with a not inconsiderable volume of water; and high up, at various levels, the hills were sometimes capped with a brown clay full of broken flints. He believed that this accumulation had been swept into its present position by tidal waters during the time when the land was being submerged and the waters were working up the valleys. At a much lower level, just before the valley widens out, there are deposits of rolled flints two or three feet thick, which creep up the slopes, and differ as much from gravel as the deposits on the hills

differ from Boulder-clay ; though he thought the two deposits might be connected in much the same way as gravels in the Eastern Counties were the residue of Boulder-clay left after tidal waters had washed the clay away. The clay had been swept out of the Findon valley. He believed the entrance to such a valley was wide in proportion to the duration of marine action upon it, and that although other agencies may have since softened its features, there was no ground for appealing to them to account for its origin.

Mr. EVANS was grateful for any new theory offering an explanation of the Elephant-bed. He agreed as to the possibility of the frozen condition of the ground, but was not prepared to go the whole length of the Author. He dissented from the views of Prof. Seeley. The question of the Elephant-bed was distinct from that of the formation of Coombes. Its age was undoubtedly subsequent to the elevation of the old submerged cliff. He considered that with a certain amount of submergence, streams of water would run in the now dry valleys. According to the Author's hypothesis, the more impervious the condition of the Chalk the more rapid would be the process of excavation. This he was prepared to accept ; but a greater rainfall would have much the same effect as frost. If the Chalk hills were saturated with water, the conditions would, as he had elsewhere shown, be very nearly the same as if the rock were frozen. Even a double rainfall might in some Chalk districts produce saturation nearly to the surface.

He strongly objected to Prof. Seeley's ideas respecting the deposit on the hill tops ; it was more probable that the heights of the South Downs were capped by a chemical deposit, which was the residuum of the chalk already removed by solution.

He again expressed an opinion that Mr. Reid's theory was well worthy of consideration.

Dr. GEIKIE had accompanied the Author over the ground and considered him to be on the right track. Without doubt the valleys were the result of subaerial denudation, and he was astonished at what had fallen from Prof. Seeley. The valleys were doubtless outlined before the Chalk was exposed at the surface, and their subsequent erosion in the Chalk had been effected by solution and mechanical abrasion under conditions which have now disappeared.

Dr. HICKS observed that Mr. Reid spoke of great cold, therefore the period he was describing must have been the climax of the Ice Age. The animals found in the Pleistocene deposits referred to were simply driven from their northern home by the advance of the ice. Man would follow the animals on which he lived ; therefore the implements obtained from these deposits belonged, probably, to the northern man, who must be considered as of preglacial age.

Mr. TOPLEY, after alluding to the breadth of the discussion, bore testimony to the value of the Author's hypothesis. It was not a new idea that the Coombe Rock represented the glacial deposits of the north of England ; but the really new point in the paper was the notion of the ground south of the area under ordinary glacial conditions having been solidly frozen ; and if the whole country were

thus frozen, the action of running water would be to excavate in the manner claimed for it. He then proceeded to institute a comparison between the conditions obtaining in the North and South Downs respectively, and stated that the absence of any deposit representing the Coombe Rock in the north, and also the fact that dry valleys existed throughout the Chalk area in Central France, were difficulties in the way of accepting the Author's conclusions. He gave some reasons for believing that the South Downs represent a later stage of denudation than do the North Downs.

Mr. PEACH thought that the theory advanced by the Author accounted for the phenomena of the dry Chalk valleys; but in order to make the Chalk impervious to surface-water, it was not necessary to have it frozen to the depth of several hundred feet. The same result would be brought about by the freezing of the ground for a few feet below the surface. The Coombe Rock was evidently connected with the excavation of these valleys. The presence in it of numerous fragments of chalk and flints not rounded seemed to indicate that its materials were laid down by streams flooded during the summer seasons and much reduced in size or frozen during the winters. The thawing of the surface during the summer would set free angular fragments of chalk split by the previous winter's frost, and the materials thus let loose would be swept down the valleys over the still frozen substratum. In this respect the Coombe Rock differs materially from the alluvial gravels of the existing streams in that region, which contain abundant rounded flint pebbles and few or no chalk fragments, the latter being disintegrated or dissolved before they have travelled any distance. The decayed character of the bones found in the Coombe Rock was in marked contrast to the fresh state of the chalk fragments, and seemed to indicate that they had been exposed to the weather prior to the formation of that rock.

Dr. HINDE observed that in Canada, where the ground is solidly frozen to a certain depth each winter, a greater amount of denudation is effected in 24 hours, at the sudden break-up of the frost in spring, than takes place during the whole of the rest of the year.

The AUTHOR, in reply, said that the valleys no doubt had been largely outlined before the period dealt with in his paper, some of them might be the continuation of old Weald valleys. The former existence of an overlying clay deposit had something to do with the original outlines. As evidence of the submergence spoken of by Mr. Evans, he instanced the marine beach at Goodwood, 130 feet above the sea. Such submergence occurred before the deposit of Coombe Rock; it might aid in the excavation of the lower valleys. As regards rainfall, the fauna is Arctic, and there should be snow rather than rain, yet we have no evidence of true glacial action. No attempt had been made at correlation with the deposits in the north. In this district the old Tertiary deposits had gone, but it was otherwise in the North Downs.

28. *The PHYSICAL HISTORY of the BAGSHOT BEDS of the LONDON BASIN.*
By the Rev. A. IRVING, B.Sc., B.A., F.G.S. (Read January 26,
1887.)

[Abridged.]

INTRODUCTION.

To the statement of my views on this subject in the Quarterly Journal of the Society (vol. xli. pp. 492, 507, 508) I adhere in its main outlines, notwithstanding the adverse criticisms upon it which have appeared since in the Quart. Journ. Geol. Soc. vol. xlii. (pp. 402–416). Certainly I felt that, from insufficiency of data, some of the correlations were tentative and open to such corrections as further investigation or criticism might show to be necessary. There can, however, be but little doubt that the method which proceeds by attempting to definitely correlate by stratigraphical evidence the strata seen in the sections on the flanks of the Bagshot district with those of the interior of the main mass involves fewer assumptions than such an attempt as has been made by later authors (Q. J. G. S. *loc. cit.*) to determine the horizons of those marginal strata by a comparison of them with one another. Underlying the latter process there is the assumption that mere contiguity or proximity to the London Clay is evidence of Lower Bagshot horizons; but this involves manifestly ‘*petitio principii*.’

I consider that the case must rest mainly on the *physical* evidence, and that, if no instance remained of a former overlap of lower by higher beds, the case would not be disproved, so long as the stratigraphical evidence was not *contradictory*; and the failure to show any overlapping at the present time could be explained by the subsequent denudation of the country, the main lines of which have been, as is well known, determined far more by the distribution of the plateau-gravels of Quaternary or earlier times than by the stratigraphical structure of the district. If later authors, therefore, had disproved the existence of overlap, they would but have disposed of the corollary to the problem, and they would still be confronted by the physical evidence. As regards the palæontological evidence, it is only right to remark that the very small percentage of the sections in the Upper Bagshot in which fossils have been found, together with the very imperfect state of their preservation (mere irony casts), suggests the possibility that the fossiliferous localities may owe that character to the mere accident of the presence of a little more binding material. Anyhow, the evidence on the affirmative side is too feeble to justify us, on the strength of its mere negation, in rejecting strata from the higher beds merely on account of absence of fossils, if physical and stratigraphical evidence justifies their assignment to such horizons. The fact that “the best-preserved specimens are high up in the series” (Q. J. G. S. vol. xlii. p. 415) may be accepted as a fact strongly corroborative of my view as to the marine-estuarine

origin of the Upper Sands, showing a gradual advance towards fuller marine conditions in those strata. So with the so-called "Middle Bagshot" group, localities may occur (*e. g.* Ascot* and Yateley†) where marine fossils are plentiful and, in some cases, in such a state of preservation as to show that they are found in their original habitat (probably the still waters of lagoons kept saline by percolation or by occasional inroads of the sea); yet there is nothing like such a general prevalence of them as would justify us in assigning a marine origin to the Middle Group taken as a whole. The most successful collector of fossils from the beds of this group has informed me that they are most numerous in certain thin whitish bands in the green earths—a fact which reminds one forcibly of the way in which marine fossils occur in thin bands in the Coal-measures‡, which no one would think of calling on that account a "marine series." Again, in other Eocene deltas, *e. g.* in that of the upper ligniferous series of the Soissonnais§ and in many modern deltas||, similar facts are so frequently met with as to be quite common-place in physical geography, as is also the fact of the gradual subsidence of estuarine areas¶. So far from there being anything "unusual" (Quart. Journ. Geol. Soc. vol. xlii. p. 416) in this, a moderate acquaintance with continental Eocene geology shows that it was but one of many incidents of a similar nature, producing frequent interstratifications of marine, brackish, and freshwater deposits, which characterized Tertiary times over a large part of the European area**. We are also confronted with the fact that in the Bagshot series of the London area there is an absence of any such record of perfect marine conditions as is preserved in the contemporary Calcaire grossier, and in the yet more massive Eocene limestones of the Bavarian Alps.

Mr. Etheridge informs me that the London Clay of the Metropolitan area yields no less than $\frac{1}{4}\frac{1}{3}$ out of the $\frac{1}{5}\frac{1}{6}$ Foraminifera known in the London Clay up to the present time, yet none of these pass up into the beds above. We must note, too, the absence from the London Bagshots of the important classes, *Actinozoa*, *Echinodermata*, *Crustacea*, and *Brachiopoda* (represented in the London Clay by 36 genera and 56 species), and the entire absence in the Lower Bagshot of the 35 genera, including 110 species, of *Lamellibranchiata* known in the London Clay, and occurring for the most part in that formation in the London Basin ††, while only 9 genera and 13 species of this class reappear in the Middle Group ‡‡. These facts seem to point to such a break in the succession of

* Quart. Journ. Geol. Soc. vol. xxxix. p. 349. † *Ibid.* vol. xli. p. 500.

‡ *Cf.* Green, 'Nature,' January 6th, 1887.

§ Meunier, 'Les Causes Actuelles &c.,' pp. 269 *et seq.*

|| Lyell, 'Principles of Geology,' chapters xvii., xviii.

¶ Green, 'Physical Geology,' pp. 292–294.

** Credner, 'Elemente der Geologie' (3rd ed.), pp. 603, 604; Zittel, 'Aus der Urzeit,' pp. 419 *et seq.* It follows from this that we must be prepared to find overlap in places. (*Cf.* Geol. Mag. dec. iii. vol. iv. p. 109.)

†† Etheridge, 'Stratigraphical Geology and Palæontology,' pp. 611–614.

‡‡ Memoirs of the Geological Survey, vol. iv. p. 600. In Quart. Journ. Geol. Soc. vol. xxxix. p. 349, two additional species are mentioned.

life-forms as could scarcely happen without some unconformity in the strata.

It is scarcely necessary to refute an objection to my view on the ground of the considerable interval of time required (Quart. Journ. Geol. Soc. vol. xlii. p. 416), an objection, which, in bringing us down to the Pliocene, seems to be based on a forgetfulness of the Oligocene and Miocene, and of the great space in time represented by the contemporary Nummulitic formation and by the subsequent elevation of some of the loftiest mountain-ranges on the globe.

The "peculiarity of the ground-plan" referred to is a misconception arising from inattention to altitudes. The northern side of the district, which I have worked more in detail, is found to come out very well on the horizontal ground-plan, as I think will be seen when it is resurveyed.

REVIEW OF THE PHYSICAL EVIDENCE.

1. *Pebbles*.—The inference drawn in my last paper (vol. xli. p. 496) was not intended to imply an absence of pebbles in the whole Lower Bagshot; and I fail to perceive how an inference from a circumscribed range of data can logically bear such a general interpretation as has been imposed upon it. To the three well-sections there cited may now be added those at Brookwood (Geol. Mag., August 1886), Chobham Place, Bagshot, Dogmersfield Park, and Claremont (Mem. Geol. Survey, vol. iv. app.), Thorpe and Hatchfold (recently published by Mr. Whitaker 'Proc. Croydon Micr. and Nat. Hist. Club,' 1886, pp. 54, 66). Neither in these nor in the extensive exposures of the Lower Bagshot on the South-western main line is there a record of them. There is some doubt whether the few "pebbles" met with in the Ascot Well* were not pyritous nodules. All this does not of course *prove a general negative*, though it increases the necessity for caution.

The alleged case recently cited †, with some emphasis, of the occurrence of pebble-beds in the Lower Bagshot at St. Anne's Hill, Chertsey, breaks down on investigation. The hill is merely an old river-valley escarpment of the Thames, which has undergone the usual process of weathering, with degradation of the higher beds, the *débris* of which is now strewn on its flanks, partly in the form of talus, as may be well seen in the large pit on the north-east flank of the hill, where the pebbles occur roughly interstratified with green earthy sand and rotten purplish clay, the crude stratification being just what one is accustomed to in sections of talus-heaps. In places, as at the top of the larger pit, small landslips are detected. The road-section up the flank of the hill shows nothing but such a confused mixture of *débris* (in this case, sand, clay, and pebbles) as may be generally observed in similar instances. The conglomeratic masses are agglutinated portions of the pebble-bed which have fallen from above.

* Proc. Geol. Assoc. vol. ix. p. 417.

† Quart. Journ. Geol. Soc. vol. xlii. p. 404.

The pebble-bed is probably seen *in situ* in a cutting made for a footpath leading to the top of the hill, and above this there appears to be a capping of sand, proved to be 16 ft. in depth on the crest of the hill, and which may be the basal beds of the Upper Bagshot. In the smaller and disused pit some of the Lower sands are well shown, having been laid bare by the removal of the pebbly *débris* which had accumulated at the base of the old escarpment*. The few patches of pebbles which remain have been formed by the simple lodgement of pebbles on a sort of ledge formed by rain-water action owing to the unequal tenacity of the beds; and they can be seen to be continuous with the pebbly surface-covering of the hill-flank by lines of pebbles standing on end in the sand, just as they would appear to have lodged in an ancient rain-water gully. In removing one of the smaller patches and a part of the principal one, to make sure that they did not run into, and become incorporated with, the stratified beds, I obtained out of the middle of the largest patch, in the presence of H. C. Leigh Bennett, Esq., the proprietor, and W. H. Hudleston, Esq., F.R.S., an angular and discoloured flint and a rolled fragment of chert, both of which are very characteristic of the later plateau-gravels of the district. On the strength of the above evidence, it may be confidently asserted that there is no trace of pebble-beds of Lower-Bagshot age † in the sections referred to or of "the existence of a pebble-bed in the Lower Bagshot of St. Anne's Hill" ‡.

Now, when it is recollected that this was the only case of a pebble-bed in the Lower Bagshot which could be adduced by two diligent observers, we may well be sceptical as to the existence of such beds, though occasional lines and layers of pebbles do occur. This being so, and the Essex Bagshot pebble-beds being of doubtful horizon §, we cannot allow the pebble-beds at Barkham, Easthampstead, and Bracknell to be claimed for the Lower Group on account of their proximity to the London Clay. Indeed *their presence is evidence rather against than for such a horizon*, for the lines and layers of pebbles met with here and there might have been furnished by the contemporaneous denudation of the London Clay itself; and no greater importance attaches to these, to my mind, than to occasional layers of Bunter pebbles in the lower sandstones of the Keuper. Their occasional presence seems to indicate inequality in the transporting power of the currents, as we should expect in a fluviatile series of beds, and this is perhaps all that they do indicate.

2. *False-bedding*.—By "false-bedding" I understand any marked departure in the stratification from a general parallelism of the

* In three surveys of the hill, I have observed nothing which requires the notion of a *fault* to explain it (see Mem. Geol. Survey, vol. iv. p. 332).

+ Quart. Journ. Geol. Soc. vol. xlii. p. 404.

‡ *Ibid.* p. 417.

§ In quoting these in the discussion of this paper, Mr. Whitaker appears to have forgotten that he had himself suggested ('Guide to the Geology of London,' p. 52) that the Essex pebble-beds may belong to the Middle Group, a suggestion with which I should entirely concur from their association with beds of the lithological character of that division (Mem. Geol. Survey, vol. iv. pp. 320-328).

bedding-planes, of which "oblique lamination" is a minor feature. That this is not a necessary indication of Lower-Bagshot horizons is seen from the simple fact that it is very commonly observed in sections of more coarsely arenaceous beds of the Middle division, and serves as one general character wherewith to link the two together, as on the whole representing a continuance of similar physical conditions, while it helps to differentiate them from the Upper Sands, in which the bedding is for the most part very indistinct.

3. *Pipe-clay*.—This need not owe its origin in these beds directly to the well-known process of kaolinization of felspathic minerals; it seems to me more likely that it owes its existence in them to the decomposition of the chalk and the leaching out of the iron by the action of peaty acids. Recent experimental study of this question has tended to confirm this view, so that I am inclined to regard the prevalence of pipe-clay as a possible indication of contemporaneous subaërial denudation of the Chalk, and of its elevation, therefore, above the sea, within the catchment-basin whose waters were drained into this Bagshot area. But this applies to the Middle as well as to the Lower group; in fact, there are greater accumulations of this mineral in the former than in the latter*. This being so, we cannot admit the presence of pipe-clay seams as conclusive evidence of a Lower-Bagshot horizon †. Further, thin layers of colourless clay are occasionally met with in sections of the Upper group in the interior of the district, as well as in some of the more sandy portions of some of the plateau-gravels.

4. *Derived Materials*.—The possible occurrence of such from the older Tertiaries in the Middle group at Brookwood ‡ has been already indicated, and Prof. Rupert Jones has suggested the appearance of derived masses of clay in beds of the same group §.

5. *Irony Concretions*.—These are at least as abundant in the beds of the Middle division as in those of the Lower. They occur in the uppermost bed of the former frequently enough. They often retain impressions of vegetable structures, or they form rough hollow tubes, just as recent bog-iron-ore often does. Some caution is needed in interpreting an apparent annular structure as a "sign of wood," since, as Roth has pointed out ||, this structure is often due to the rolling in a dry season by the wind, and subsequent burial, of partly dried and curled-up portions of the carbonaceous and ferruginous mud which is found at the bottom of stagnant pools of water. I have in my possession specimens of ferruginous concretions from a high horizon in the Middle division, which retain impressions of vegetable structure, suggestive of such marsh-loving monocotyledonous plants as belong to the orders *Cyperaceæ*, *Typhaceæ*, &c.,

* Cf. the Brookwood Well-Section (Geol. Mag. dec. iii. vol. iii. p. 355); the Well-section at Wellington College (Quart. Journ. Geol. Soc. vol. xli. p. 494); also the instance mentioned in the Survey Memoir on the London Basin (vol. iv. p. 333) near Worplesdon.

† See Quart. Journ. Geol. Soc. vol. xlii. p. 411.

‡ Geol. Mag. *loc. cit.*

§ See Proc. Geol. Assoc. vol. vi. p. 433 (footnote).

|| 'Allgemeine und chemische Geologie,' p. 597.

and many of the smaller concretions are undistinguishable from the bog-iron-ore obtained from the Canadian and Swedish lakes. Moreover they are often found on analysis to contain a basic crenate of iron. Fragments of lignite are, in my experience, not uncommon both in the Middle and Lower beds. The process by which iron is carried down in solution by peaty acids and deposited mainly as hydrated ferric oxide (bog-iron-ore) is well known*. This is, no doubt, the true explanation of the agglutination by ferric oxide of the gritty sands and conglomerates of the plateau-gravels known locally as 'pan' or 'rust.' It may still be witnessed in most of the streams of the peaty waters of the present Bagshot country. Many of the more sandy nodules were first agglutinated by iron-pyrites, since such are common in their original state and may be observed in all stages of oxidation. Sometimes they contain pure 'silver sand' in the interior.

6. *Results of Chemical Analysis.*—These have been already in part published †, so far as regards combined carbon. Those results have been confirmed by several scores of analyses since made of samples of these carbonaceous beds and of the waters they yield ‡. Independent confirmatory evidence has also appeared §. Recently I have made about 25 combustion-analyses ||, in order to get out the percentages of *elementary* carbon. These percentages range from 0.312 up to 1.950, the highest being given by the very dark green earthy sands of the Middle Bagshot. On the other hand, an average sample from the basal beds of the Upper Bagshot in this neighbourhood gave only 0.17 per cent. The samples analyzed came from different parts of the district, the majority of them from well-sections. Elutriation of some of the green earths removes nearly the whole of the green colouring-matter, the fine amorphous earthy matter acting apparently as a 'mordant,' and leaves behind white quartz-sand mingled with some black and olive-green grains. This probably partly explains the tenacity of colour of some of these green earths; yet chemistry teaches us that they *must*, and observation shows us that they *do*, lose their colour by oxidation. Slow oxidation is only a less intense phase of the process of combustion in oxygen; and the burnt residues of these green earths are so completely discoloured as to be undistinguishable from those of the brown sands and clays;

* See Roth, *loc. cit.* pp. 596–598 (worth the attention of those who are sceptical as to the existence of the *Humussäure*); Credner, *El. der Geol.* (3rd ed.) p. 255; Julien, "On the Geological Action of the Humus Acids," *Proc. Am. Assoc. Sci.* (1879); also the author's papers in the *Geol. Mag.* January 1885, and elsewhere.

† *Geol. Mag.* dec. ii. vol. x. (1883).

‡ See remarks by the author in *Proc. Inst. Civil Engineers*, vol. lxxxv. (1885–86).

§ See (1) *Quart. Journ. Geol. Soc.* vol. xlii. p. 162; (2) *Sanitary Record*, June 1886. Lecture by W. Eassie, Esq., C.E., F.G.S. A reply to Mr. Blyth's criticisms of that lecture will be found in the following (July) number of the same periodical.

|| Made by combustion in a stream of purified and dried oxygen. The accuracy of the method was tested by analysis of a specimen of graphite from Borrowdale.

while even the darkest green earths (*e. g.* at St. Anne's Hill) may be observed coloured in places of a bright orange-red by slow oxidation. It is trivial to argue from the small amount of colour-change observed in some instances (*e. g.* at Goldsworthy, Q. J. G. S. vol. xlii. p. 415) to a negation of such change during the ages for which some of these beds may have been exposed near the surface. Moreover, it requires a comparatively dry exposure to allow of the penetration of the beds by oxygenated rain-water; and cases may occur in which the beds are kept so saturated with water from the interior of the beds holding carbonaceous matter in solution, that the work of oxidation may be arrested altogether.

7. *Microscopic Structure.*—A detailed examination of the specimens from the Wellington-College Well-section, subdividing the beds for this purpose as they are given in vol. iv. of Mem. Geol. Survey, p. 425, shows sizes of the quartz-grains ranging from 0.005 to 0.030 of an inch. A pure clay is seldom met with. Even the so-called clays of the Middle group contain very often some 50 per cent. of fine clear quartz-grains, cohering in masses by the cementing action of the argillaceous material. In the Upper group the investment is generally a mere clay; in the Middle and Lower there is generally more or less of amorphous organic matter, either of itself constituting the investment or mingled with clay*. The quartz-grains are for the most part subangular, and therefore water-worn. In one bed (no. 7) the majority of the grains were found to be well rounded; and in beds no. 8, part of 9, and 11, there was a noticeable proportion of rounded grains. In some of the beds a considerable quantity of glassy silica, in minute clear flakes, is seen. This glassy silica may consist partly of fragments of frustules of Diatoms; but hardly so the larger flakes. These have the appearance under the microscope of flakes of silica artificially precipitated by a process well known in chemical laboratories. If so, the solvent action of the humus-acids upon silicates may have contributed to the result.

8. *Distribution of the Sarsens.*—A careful investigation of the matter which I have recently made has tended strongly to confirm the statements of Profs. Prestwich † and Rupert Jones ‡, as to the occurrence of these blocks and slabs of 'saccharoid sandstone' in the Upper Sands. The probable *genesis* of them has been discussed by me elsewhere §. Their extensive distribution far beyond the present range of the Bagshot strata is well known. The larger blocks are generally very angular, sometimes water-worn on the upper surface, but rough and uneven beneath. As a student of glaciation, there seem to me insuperable physical difficulties in the way of attributing to them a morainic origin. For these reasons it seems that their wide distribution may be regarded as indicating

* Geol. Mag., September 1883.

† See Quart. Journ. Geol. Soc. vol. iii. p. 384.

‡ Proc. Geol. Assoc. vol. vi. p. 436.

§ Report of Brit. Assoc. (Southport Meeting), 1883; also Proc. Geol. Assoc. vol. viii. pp. 156-160.

a much greater areal extension originally of the Upper Sands, which harmonizes with the view advocated in this and in former papers.

9. Lastly, the general homogeneity of the Upper Sands, when viewed on a large scale, as contrasted with the numerous lithological variations, laterally as well as vertically, of the Middle and Lower beds, points to such an agency as a tidal surf, in working up the various materials, brought into the estuary from different parts of the catchment-basin, into a somewhat homogeneous whole, as we see them in the Upper Sands; while the absence of such an agency in the Lower and Middle stages led to that differentiation of the deposits just referred to, the materials contributed by each affluent being more or less locally deposited. These lateral variations in thickness and lithological character of beds on the same horizon constitute, indeed, the chief difficulty of their stratigraphy, and discount largely the value of conclusions drawn from a comparison of small and distant sections. Such evidence standing alone cannot be other than equivocal.

Freshwater Diatoms &c.—It would be premature to say much of these until the investigation has been carried further. Up to the present they have only been found in any quantity in three beds in different localities, though many samples have been searched and stray forms have been found in others. The sands examined have been washed with *distilled* water. Their fossil condition seems to be indicated (1) by the absence of endochrome, (2) by the corroded and fragmentary condition of many of them*. The work of Prof. E. Pfitzer, of Heidelberg, has been mainly consulted in this study. He confirms the previous judgment of Smith as to the distinction between marine and freshwater forms, and points out their importance from this point of view as geological data. He assigns $\frac{1}{3}$ millim. as the limit of size of freshwater species; those which have been found in the Bagshot Beds seldom reach $\frac{1}{4}$ millim. in length. "Along with empty frustules of Diatoms," he says (*loc. cit.* p. 408), "only spicules of freshwater sponges and silicified remains of many higher plants are generally present." The latter, in the form of vascular tissue, appear to be more common in the Bagshot Beds than Diatoms. They are distinctly luminous in a dark field between crossed nicols, and remain unchanged after being calcined for more than a quarter of an hour on clean platinum foil. I am not sure that I have seen any sponge-spicules. The following may be mentioned as genera that have been met with:—*Gomphonema*, *Frustulia*, *Pinnularia*, *Synedra*, *Gyrosigma*, *Navicula*, *Odontidium*, *Melosira*, *Amphipleura*. They occur both in the Middle and Lower Bagshot, and none have been met with in the Upper Bagshot. [In a sample of the Kieselguhr deposit lately discovered at L. Quire in Skye, for which I am indebted to the courtesy of A. Macdonald, Esq., of

* *Vide* Schenk's 'Handbuch der Botanik' (Breslau, 1882), Bd. ii. pp. 409 *et seq.*, also fig. 1 of that monograph (p. 407). I offer here my best thanks to Prof. Marshall Ward, of Cooper's Hill College, for directing my attention to this, Pfitzer's latest published work.

Portree, I find pretty nearly the same genera occurring in a very similar state.]

STRATIGRAPHICAL EVIDENCE.

Data for Section A (fig. 1).—The well-section at Wellington College (see Quart. Journ. Geol. Soc. vol. xli. p. 494) is the standard for comparison. The sequence of the beds at the southern end of the section has been proved again in a new well, this winter, behind the Wellington Hotel. The thickness of the sand beds below no. 10 is calculated (from the altitudes of the London Clay in the College well-section and at its outcrop to the N.W.) as 80 feet. The green earthy sands (nos. 7, 8) are proved by outcrop and intermediate excavations to continue to the brook parallel to the railway $\frac{1}{3}$ mile to the E.

Section B. *Brook-section south of Ravenswood.*

	ft.
<i>a.</i> Green earths and sands (nos. 7, 8).....	20 to 25
<i>b.</i> Clays, loams, ferruginous sands with strong clay-layers } (nos. 9, 10)	20

On the west side of the line the well at the lodge by the Roman Road pierced beds nos. 9, 10, 11. The last-mentioned bed is a dirty quartz-sand, blackish green, with much lignite and pyrites.

Section C. *New Well by Wokingham-Sandhurst Road.*

	ft.
<i>a.</i> Angular and pebbly drift-gravel.....	6
<i>b.</i> Brown and yellow ferruginous sand, loam and clay (partly laminated), with iron nodules, very clayey in upper part (nos. 9, 10)	} 21
<i>c.</i> Greenish-black quartz-sand with pyrites, lignite, and freshwater dia- toms (pierced to)	} 5
Total depth	32

On the assumption that things which are equivalent to the same thing are equivalent to one another, I maintain that the beds of the new well are precisely on the same horizons as those in the well at the lodge (see fig. 1), since the upper bed in each of the wells is the equivalent of the beds nos. 9 and 10 of the brook-section (B). North of the new well the beds nos. 9 and 10 are cut through by the brook; but no. 9 is recognized at the top of the hill just N. of Jack's Bridge (see Ordnance map); and the base of no. 10 is exposed some 20 ft. lower in the banks of King's Mere, the bottom of which basin is in no. 11, a fine quartz sand*. Nos. 9 and 10 can be recognized in the railway-cutting both N. and S. of Nine-mile Ride. There are two larger exposures of no. 10,—(a) in a sand-hole by the roadside, (b) in the railway-cutting (see fig. 1) $\frac{1}{2}$ mile N. of the road. Beneath no. 10 the fine quartz-sand of no. 11 is well exposed

* The lake was dried up last summer. The above statement is from my own observation; the previous statement (vol. xli. p. 503) was made from information given me by others.

along the small brook-escarpment a little way to the west and parallel to the railway. It is seen a little way further north in a dipping-well by the east side of the line, and in the banks of the brook on both sides. In the wood to the east it passes under beds nos. 9, 10, which form a small plateau through Gorrick Plantation, on the N.W. corner of which *bed no. 10 appears to touch the London Clay in the ditch outside the fence.* The presence of the latter formation is further shown by oak trees, by the presence of Silverstock Bog (see Ordnance map), by the fact that the clay was dug into in draining last summer, and was dug for brick-material about $\frac{1}{3}$ mile to the west a few years ago. The bed seen in the cutting a little further north must be a continuation of no. 10, both lithologically and by the features of the ground; and it appears to be continued through Luckley Park, on the north side of which it is only cut off from the Wokingham outlier by the line of erosion of the Emm Brook. It is exposed just north of this in a small road-section, and it forms a small plateau, which is cut through on the railway, where the base of no. 10 is seen, sharply defined from no. 11 (here well cleaned by oxidation), at 210 (O.D.).

The following small clean section in the brook-side south of Ravenswood shows the mixed character of bed no. 10*, and the consequent impossibility of determining its dip by comparison of small sections of it.

Section D. *Bank of Brook near Ravenswood.*

	ft.	in.
a. Drift.....	3	0
b. Stiff loam, yellow and brown.....	1	0
c. Rather strong clay, yellow and brown.....	0	9
d. Strong loamy sand with thin pipe-clay partings and red and puce- coloured ferruginous layers.....	3	0
Total exposure	7	9

A rough analysis of a sample from the same bed a little further down the brook gives:—free silica, 60 per cent.; clay, 25 per cent.; ferric oxide, 13.5 per cent.; sodium chloride, 0.5 per cent.; water of hydration, about 1 per cent. This bed is, in fact, so variable that I mistook portions of it in the railway-cuttings for bed no. 4; and this was the main, though not the only, reason why I suggested an anticlinal in my previous paper. Along this line of section A (fig. 1) the dip, as indicated by the base of bed no. 10, would appear to be about from 10 to 15 ft. in 3 miles; but the true dip is probably somewhat greater and in a more easterly direction, to judge from the general strike †.

Numerous well-sections in Wokingham give the same succession of beds as we find in the Tangley cutting. Everywhere the water

* It is by no means so "homogeneous" as one would suppose from the well-specimen.

† More correct determination of levels shows that the pebble-bed in the lower lake at Wellington College is on the horizon of no. 6. That on the horizon of no. 3 has been proved higher up the valley at 264 (O.D.).

is obtained from a fine quartz-sand resting on London Clay. There is no record of a passage-bed. The sharp distinction between the sands and the London Clay (see fig. 4, vol. xli. p. 505) is borne out by excavations on the cutting-slopes, and by my observation of open graves in the churchyard.

Elevation of Beds due North from Wellington College.

Section E. *Valley $\frac{3}{4}$ mile North of Wellington College.*

References to numbers in well-section (Quart. Journ. Geol. Soc. vol. xli. p. 494, fig. 1). Corrected altitude 287, O.D.

	ft.
No. 3. Pebble-bed in stiff loam (about)	2
No. 4. Coarse loamy ferruginous sand with iron concretions	3
No. 5. (Wanting.)	
No. 6. Strong loam and clay (brick-material)	6
Nos. 7, 8. Green earths throwing out springs about the middle and at the base	} 20
Nos. 9, 10. Clay-and-sand beds, more sandy in the middle, not distinctly differentiated, coarse and ferruginous, with iron concretions...	} 20
No. 11. Fine sharp quartz-sand, with glassy silica	(depth) ?

There are several exposures of one or more of these beds a little way east and west of the road, and they can be traced to the brook to the west (section B). Nos. 9 and 10 are cut through in the valley, and are exposed on the north side of it by the road; but further to the east they form a higher feature of the ground, and extend across Nine-mile Ride, on the south of which about 5 ft. are exposed in a brook-section, while on the north side of the road the clays of these beds are worked in the new brick-yards. The same fine quartz-sand is proved here beneath them in several wells and trial-holes. The clay-beds here, with their included iron concretions, are identical in character with those dug at the California brick-kiln (see *infra*, p. 385); and both are identical with bed *b* (no. 10) in the well (section C, p. 382). On the west side of the New Wokingham Road beds nos. 9 and 10 form the higher feature of the ground by Heathlands (base of no. 10 exposed in a sand-hole) and St. Sebastian's Church, where the graves pass through 5 ft. of no. 10 into the fine quartz-sand of no. 11.

The general strike of no. 10, so far as it can be made out, and the outcrop of the London Clay (I have verified the mapping) along the small valley south of Rouse's Farm, Easthampstead, gives less than $\frac{1}{2}$ mile for the outcrop of the 95 ft. of the sandy beds nos. 11, 12, 13, of the well-section; and this, by ordinary rules of stratigraphy, would give something like 1000 ft. for the thickness of the London Clay and Reading Beds, as calculated from the outcrop of the Chalk at St. Lawrence-Waltham, 6 miles due N., if those three beds main-

tained the same thickness here as in the well-section. They must therefore have thinned away considerably.

Again, a comparison of altitudes gives the following data:—

Altitudes at W. Coll.	Altitudes at outcrop.	Distance.	Rise.	Ratio.
No. 3 264	264	4380 ft.	0*	—
Base of No. 10 ... 187	214	5544 ft.	27 ft.	1 in 205
Surface of L. Clay 92	200	3460 yds.	36 yds.	1 in 96

By ordinary rules of stratigraphy (rejecting the notion of east and west flexures), no. 3, if continued, would cut through the Easthampstead and Bracknell Hills at about the altitude at which a pebble-bed is found there; a rise to the north of 1 in 205 for base of no. 10 would give 272 (O.D.) along the same line of country (see fig. 2), which with further subsidence to the south gives a lithologically equivalent bed at Bracknell and Buckhurst, in each case underlain by a fine quartz-sand (see *infra*, p. 387), while intermediate outliers of it at intermediate levels are met with on the north side of Easthampstead Park; and a rise of 1 in 96 for the surface of the London Clay gives 274 (O.D.) along the same line of country, the difference between this and the general altitude of that formation beneath the Bagshot beds along that line of country representing probably the amount of contemporaneous denudation of the London Clay. Reasoning from these data, we should expect to find that *the green-earth series and the quartz-sand series were represented very feebly, if at all, at Buckhurst and Bracknell*; and so the difficulty arising from the non-appearance of the green earths in the Bracknell cutting (Quart. Journ. Geol. Soc. vol. xlii. p. 406) vanishes.

Elevation of the Beds N.W. from the Well-section.

When this paper was read a diagram showing a continuity of levels in beds nos. 3 to 7 to the N.W. from the College-well was shown †. It was constructed by correlating, *according to altitudes*, minor sections at the railway-cutting, in the new well behind the Hotel, in the pine-woods near Heath Pool, and in the lane below Wick Hill Farm (Upper Bagshot), taking the intermediate features of the ground into account. A detailed section (constructed from excavations made for me last autumn, the measurement of the beds in the fresh section, and a correlation by measurement of the levels of the beds in the two subsections, one in the old clay-pit, the other in the California brick-yard) was also shown and described. Here it will suffice to state, as the outcome of the investigation, that (1)

* Further investigation has shown that this level is maintained for about half a mile south of the College.

† Cf. Whitaker, Quart. Journ. Geol. Soc. vol. xviii. p. 263.

the clays worked in the California pits are the beds nos. 9 and 10 of the well-section; (2) that the section published last year (Quart. Journ. Geol. Soc. vol. xlii. p. 409, fig. 2) is erroneous in several important particulars, (*a*) in the altitudes (error of about 15 ft.), (*b*) in the omission of the middle beds of the section, (*c*) in the assignment of too small a thickness to the clayey beds of the brick-yard. The evidence, and that furnished by a comparison of numerous other sections in the neighbourhood, including sections on both sides of Finchampstead Ridges, is altogether against the assignment of the California clays to the Lower Bagshot. The outcrop of the London Clay in the pit at the west end of Nine-mile Ride and at Barkham demonstrates therefore, when altitudes are taken into account, the attenuation of beds nos. 11 and 12 of the College well-section also in this direction. On the strength of the stratigraphical evidence, of which only the salient points are here briefly indicated, I re-assert my entire agreement with the judgment of the Officers of the Survey in mapping the California clays as the basement-beds of the Middle Bagshot. The train of reasoning which is based on the assignment of these beds to a Lower Bagshot horizon (Quart. Journ. Geol. Soc. vol. xlii. p. 408) seems to me, therefore, to fall to the ground. The base of no. 10 is 215 (O.D.), about the level of the base of the same bed in section E (p. 384), $1\frac{1}{2}$ miles due east of this point.

Fig. 2.—*General Section.*

For details of the Bearwood outlier, see Geol. Mag., March 1887; for the Wokingham outlier, see *suprà* (p. 383) and my former paper (Quart. Journ. Geol. Soc. vol. xli.). The Buckhurst outlier is probably for the most part Upper Bagshot*. As to the Bracknell outlier the following sections should be considered:—

Section F. *Warfield Brick-yard (North end of outlier).*

	ft.
a. Coarse brown iron sand with iron concretions and irregular layers of strong white unctuous clay (? a Bagshot bed)	8
c. Pebble-bed in loam with included lumps of pink and white clay	1 { about 260 (O.D.)
d. Laminated clay-and-sand beds, with ferruginous concretions (a "mellow loam" when well mixed), <i>horizontal in sections at right angles</i>	5
e. Dark-coloured sandy clay passing down into ordinary London Clay with a true dip of 10° in a direction 20° S. of E. (exposed to)	31
Vertical exposure	45

This, it is seen, furnishes *direct evidence of unconformability*. The dip is shown by even layers of pebbles and a calcareous rocky fossili-

* Judging from road-sections and from the loose materials brought up from a well 52 feet through the yellow sands. In the railway-cutting beds nos. 10 and 11 rest on a highly eroded surface of London Clay.

ferous layer (not *Septaria*) running through the London Clay. In the brickyards a little further west, a layer of pebbles shows a dip of 5° about S.E. for the London Clay.

Section G. *Bracknell Station.*

	ft.
<i>a.</i> Surface-soil containing numerous flint-pebbles	1 (at 265 O.D.)
<i>d.</i> Laminated clay-and-sand bed with iron concretions (sand apparently once a greensand)	} 10
<i>e.</i> Dark greyish-black carbonaceous fine quartz-sand (con- taining 2.5 per cent. of C and freshwater diatoms) ... }	
Total exposed	13

NOTE.—“*e*” = bed “*a*” of my previous section (vol. xli. p. 505).

Section H. *Cutting-slope 200 yards East of Bracknell Station.*

	ft.
<i>b.</i> Loamy sand with pebbles at the surface.....	10 to 15
<i>c.</i> Pebbles imbedded in a stiff loam.....	1 (265 O.D.)
<i>d</i> ₁ . Buff-coloured loamy sand	3
<i>d</i> ₂ . Laminated clay-and-sand bed with ferruginous concre- tions, the lowest 8 inches a black shale	} 5
<i>e.</i> Dirty quartz-sand (exposed in excavation to)	
Total exposure in a fresh excavation	22

Before the recent eastward extension of the up-platform a well was dug in bed “*e*” by Mr. Ripley, below the level of the line. He is positive that it was not London Clay, as he knows it in the neighbouring brick-yards.

Section I. *Easthampstead Church (South end of outlier).*

Combining the well-section at the village school, the road-section above the church, and the road-section below the church.

	ft.
<i>a.</i> Quaternary or pre-quaternary gravel (angular flints, pebbles, and chert)	} 1 to 2
<i>b.</i> Loamy yellow sand (probably Upper Bagshot) reconstructed near the gravel	
<i>c.</i> Pebble-bed, seen <i>in situ</i> in the churchyard, in the road- cutting below the church, behind the cottage opposite, well exposed in excavations last summer at the workhouse ... }	} 3 (260 O.D.)
<i>d.</i> Clay-and-sand bed (similar to bed “ <i>d</i> ” in the above sections F, G, H)	
<i>l.</i> London Clay seen in the road a few feet above the brook...	?
Total of Bagshot exposed	33

The laminated clay-and-sand bed I take to be the same in all the four sections. It runs through the hill, and is seen in the lane which crosses the outlier north of Wick Hill House. Its altitude throughout is 250 to 260 (O.D.). There is a higher pebble-bed in

* From data in the road-cutting, in a well close by, and in the graves in the churchyard.

the probable Upper Bagshot, 5 ft. thick in the cutting 550 yards east of the station, and 5 ft. below the surface, said to be 6 ft. thick in a well 70 yards north of the cutting. Space compels me to omit here full details which I possess of other well-sections in this outlier; but it must be stated that in two of them, at the foot of Bill Hill (330 ft. high), "*green sand yielding putrid water*" is recorded, and beds of pebbles in these and in two others (6 in. to 24 in. thick) were met with, at about 265 (O.D.). There is a very good section of Upper Bagshot at the south end of Bill Hill, at about 300 (O.D.). The dip discovered at Bracknell, and the trend somewhat to the north of the general strike of the London Clay may account partly for the altitude ($250 - 118 = 132$ (O.D.)) of the surface of the London Clay in the Ascot well. The specimens which I have from that well show (1) real "blue clay" at that depth, (2) a striking correspondence of the sandy beds for some distance higher with nos. 11 to 13 of the Wellington well-section. A nearly perfect shell of a *Cerithium* is in my possession, probably from still higher beds, very likely equivalents of nos. 9, 10, and of the laminated clay-and-sand bed at Bracknell. The last is certainly not the bed which occurs next above the London Clay in the Ascot well.

I believe that beds of about the horizons of nos. 9 and 10 run through this side of the country, and rest, in places, on the eroded London Clay surface at Wokingham, Buckhurst, and Bracknell*; that is to say, there is a certain (not very great) double unconformity, beds not the lowest of the Bagshots resting upon beds not the highest of the London Clay. The evidence can only be really estimated on the ground, and will have to be taken into account in a resurvey of the district. If such marginal conditions exist, we must be prepared for some things "unusual" (Quart. Journ. Geol. Soc. vol. xlii. p. 406), such as the occurrence of a pebble-bed in the Upper Bagshot, the objection to which is, moreover, neutralized by the record of pebbles at Pirbright (*loc. cit.* p. 414).

GENERAL CONCLUSIONS.

1. My recent work, of which a mere outline is here given, tends to bear out the general conclusions arrived at in my previous paper (Quart. Journ. Geol. Soc. vol. xli. pp. 506-508), except on one or two points.

2. The Bagshot Beds of the London Basin are, upon the whole, an estuarine series, which admits of differentiation, both on physical and palæontological grounds, into:—

- (a) An upper *marine-estuarine group* (= "Upper Bagshot Sands").
- (b) A lower *freshwater group* (= "Middle and Lower Bagshots").

* Local erosion on a minor scale is a matter of direct observation at all those three places. The occurrence usually of a few feet of fine quartz-sand beneath those beds shows the absence of a "passage" between the two formations (*cf.* Mem. Geol. Surv. vol. iv. pp. 316, 317).

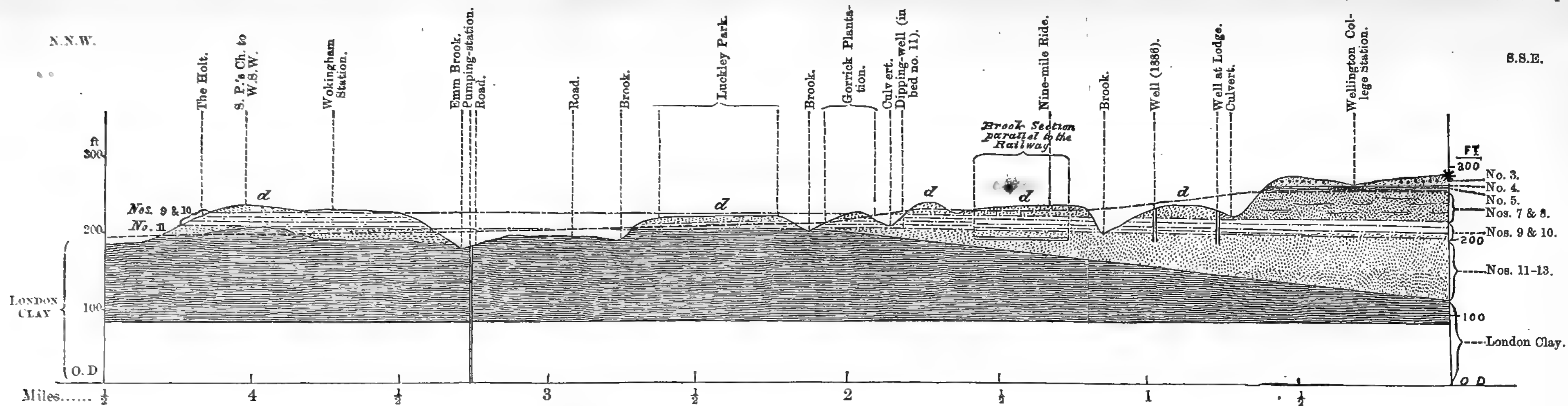

----- Line of Railway: the gradients kindly furnished by the Company's Chief Engineer, F. Brady, Esq.

* Level of mouth of Wellington College Well (287 O.D.), 1/2 mile E.N.E. of this point. The reference-numbers indicate the corresponding beds in that well (see Q. J. G. S. vol. xli. p. 494). B. Latham, Esq., O.E., F.G.S., has kindly furnished exact levels for the vicinity of Wellington College.

Note.—For the Wokingham Outlier the line of section is taken a short distance east of the railway.

- d. Drift-gravels.
- No. 3. Pebble-bed.
- No. 4. Irregularly stratified sandy loam, with green grains, thin seams of white clay, and iron concretions.
- No. 5. Interlaminated clay-seams and green sands.
- MIDDLE BAGSHOT { No. 6. In the well-section and in the neighbouring brick-fields a bed of flint-pebbles; not proved on the railway, beyond a mere line of pebbles.]
- No. 7 & 8. Green earths and sands.
- No. 9 & 10. Mixed clays, loams, and coarse ferruginous sands [basement-beds of the middle group].
- LOWER BAGSHOT { No. 11-13. Fine quartz-sand (in the well-sections carbonaceous, with lignite and pyrites nodules; dark grey-green), with little or no iron where cleaned by slow moist oxidation. No. 13—a fine sandy clay [passage bed].
- LONDON CLAY.

Fig. 2.—Horizontal Section from the River Loddon to Ascot Race-course.

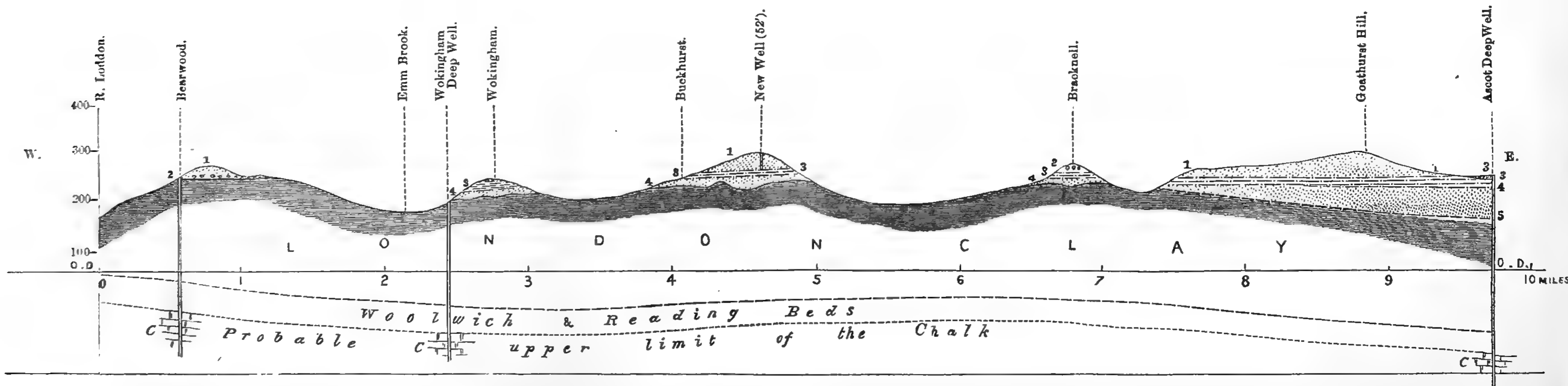

- 1. Upper Bagshot Sands.
- 2. Pebble-beds (occurring at two distinct horizons at Bracknell).
- 3. Middle Bagshot Clays and ferruginous loams (probably = Nos. 9 & 10 of fig. 1).
- 4. Lower Bagshot fine quartz-sand (a few feet only in the outliers; in some places wanting).
- 5. Passage-bed.
- C. Chalk, proved in the deep wells at Bearwood, Wokingham, and Ascot.

Note.—The erosion of the London Clay beneath the Bagshot outliers is known from minor sections; the boundary in the Ascot region (indicated by the broken line) is inferred.

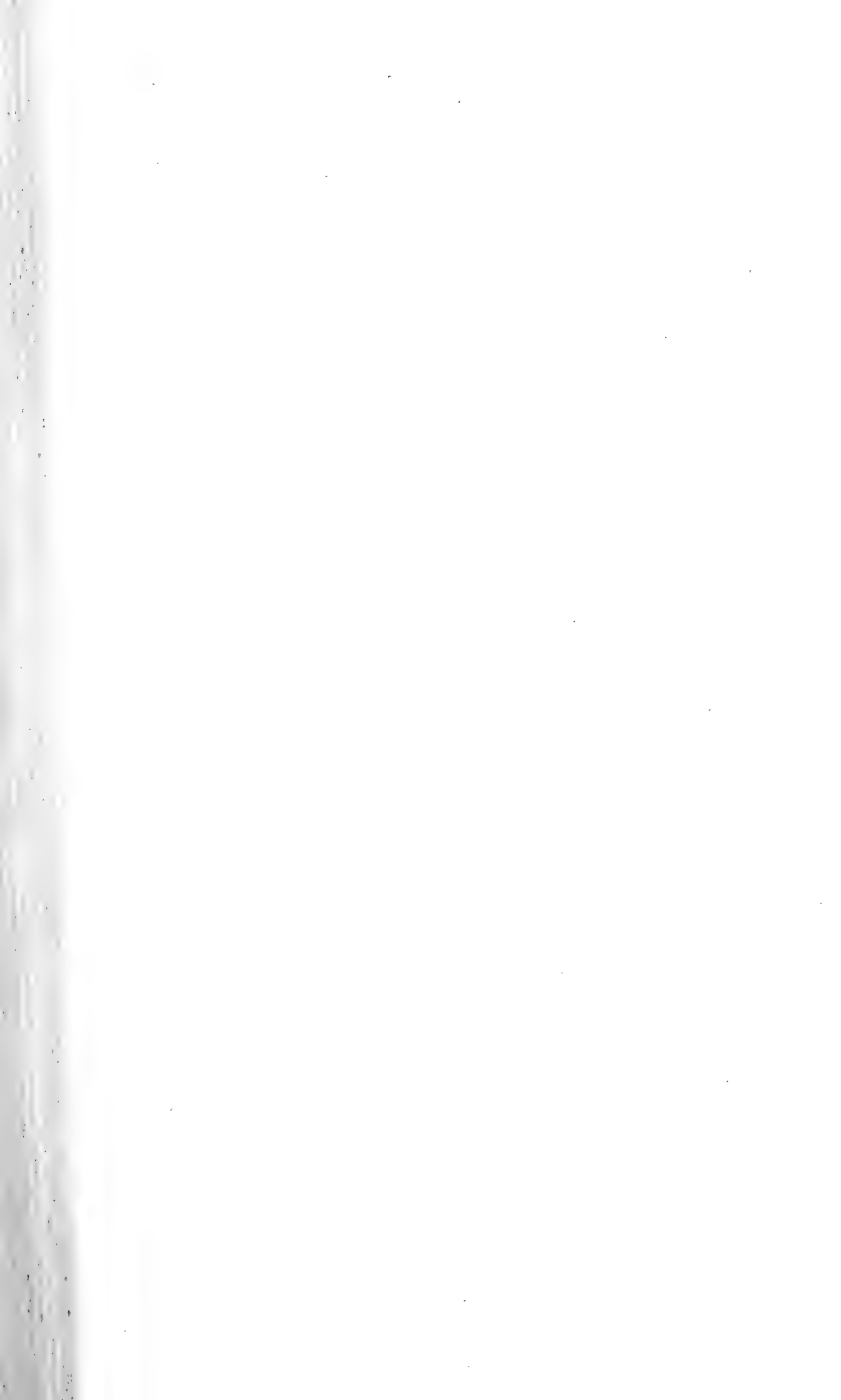

The so-called "Lower Bagshot" I regard as essentially *fluvial*, the so-called "Middle Bagshot" as, upon the whole, *delta* and *lagoon deposits*, the lagoons having been partially saline, perhaps by occasional intrusions of the sea and by percolation through fringing shingle-terraces, the conditions represented by the "Middle" beds being feebly anticipated in different localities and at different horizons in the "Lower" series.

3. The lower levels of the Middle series towards the east (as shown in well-sections) may perhaps be due to a general subsidence, the true deltaic conditions encroaching upon the land as subsidence progressed, so as to give a certain parallelism between beds of this horizon towards the west and the earlier deposits of the "Upper" sands towards the east or seaward margin of the area.

4. Though we fail to find such evidence on the south flank, we have on the north flank of the area strong cumulative evidence of *marginal conditions*, and consequently an indication of the northern limit of this Eocene estuary at successive stages of the process.

5. Massive pebble-beds belong for the most part to the "Middle" group, though occasionally occurring at low horizons in the "Upper" group, and afford the strongest evidence which the whole series offers of important changes in the relations between sea and land at about that stage of the deposition of the Bagshot Beds.

NOTE.

With regard to the southern margin of the district, it is only right that I should make here the following quotation from the original MS. of the paper which was in the hands of the Officers of the Society at the end of last year:—"It was my intention to deal with the southern margin of the Bagshot area in this paper; but, as the work has grown to considerable dimensions, and as other duties have prevented me from dealing so thoroughly with the details of that side of the district as I could wish, as, moreover, the Aldershot district is somewhat complicated and is being worked out by my friend and former pupil, Lieut. H. G. Lyons, R.E., F.G.S., it has appeared better to defer the fuller consideration of it for a future communication." I only add now (April 30th) that in the part of the paper which appeared in the Society's Journal (vol. xlii.) last year, dealing with this portion, there are many points which I consider open to criticism; but these are dealt with in Mr. Lyons's paper. The evidence recently furnished by the Brookwood well-section shows that the notion of the possible occurrence of Reading Beds in the Mytchett section is quite untenable.

ERRATUM.

In my former paper (vol. xli. p. 508, line 4):—

for Lower Bagshot read Upper Bagshot.

DISCUSSION.

The PRESIDENT observed that of the many interesting matters discussed the most striking was the discovery of freshwater Diatoms. He uttered a caution, however, as to the possibility of their not being of the age of the beds in which they were found.

Mr. MONCKTON allowed that the paper contained many new facts. His own hypothesis certainly differed from that of the Author, who had a better working-case than on a previous occasion. Indeed he might not be far from being correct, though there were still reasons for doubting this. As regards St. Anne's Hill, he admitted that possibly there might be no pebbles *in situ* in the Lower Bagshots, but he thought that appearances which mislead here might do so at other points. In the Middle Bagshots there are undoubtedly marine shells to deal with, the bivalves usually having both valves united. He admitted the occurrence of pebbles in the Upper Bagshots on Pirbright Common, having there found pebbles with fossils attached to them.

Referring to the Wellington-College section he criticized the lines as there shown, remarking that in point of fact the lines of the London Clay and the Bagshots coincide in their rise and fall. The London Clay thickens steadily eastwards—at Wokingham under 300 feet thick, at Chertsey nearly 400 feet, at Claremont 450 feet. He doubted the views of the Author as to there being unconformity at one place, *e. g.* Wokingham, and passage-beds at another, *e. g.* the Brookwood well-section. Clays occur at the base of the Lower Bagshot, both where unconformity is alleged and where a passage-bed is said to exist. He suspected that in well-sections the Author recognized a passage-bed, and on the surface an unconformity.

Mr. HERRIES claimed certain beds referred by the Author in his Wellington-College section to the Middle Bagshots as really belonging to the Lower Bagshots, in which case the surfaces of the London Clay and Lower Bagshots would conform. He criticized the Ascot section, especially the alleged valley of erosion; he regarded the depression in the London-Clay surface there shown as in reality due to dip, since the Chalk is actually 67 feet more below O. D. here than at Wokingham. Referring to the discovery of Diatoms, he saw no reason why there might not be intercalations of freshwater beds in the marine Middle Bagshots. He still maintained that the clays in the California brickfield belong to the Lower Bagshots, which usually contain a clay-bed.

Mr. HUDLESTON complimented the Author on his perseverance in again ventilating this subject. We might agree to the general proposition, but not to the reasons brought forward in support of it. Mr. Irving was determined to establish an overlap on the flanks of the basin; a year and a half ago this was to have been effected by means of certain anticlinals. The anticlinal in the Wellington-College section was now given up, and he was sure that the anticlinal at Aldershot would have to share the same fate. This would be shown in detail to the Society by Lieut. Lyons, R.E., now unfortunately

absent on duty at Devonport. That officer writes: "I cannot make out a case for erosion or overlap." In the present paper the Author had changed his tactics, and was endeavouring to establish the overlap by means of an attenuation of the Lower Bagshot Beds towards the margin of the basin. The evidence brought forward was not satisfactory. There are most undoubted clay-beds of considerable importance in the Lower Bagshot. A very remarkable one is now being exposed in continuation of the Walton cutting described last year. The base of this may be about 30 ft. up in the Lower Bagshot series. On or about the same horizon is the brick-earth of Hatch, between Addlestone and Chertsey, marked as Middle Bagshot in the Survey Map; this presents some very curious features. He fully agreed with Mr. Irving's interpretation of the alleged presence of pebbles in the Lower Bagshots of St. Anne's Hill. The pebble-beds of the Middle Bagshots were largely developed in the upper part of the hill, and these had fallen over in large masses. Still the absence of pebbles in the Lower Bagshots of this part of West Surrey could not be taken as evidence that pebbles never occurred in the Lower Bagshots.

Mr. WHITAKER missed the apocrenic acid of previous papers. Mr. Hudleston had partly anticipated the substance of his remarks with reference to the non-occurrence of pebbles in the Lower Bagshot. We must bear in mind that pebble-beds occupy but a very small part of the country. In Essex there are quantities of pebbles in the Lower Bagshots. In Hampshire pebble-beds over large areas are most distinctly capped by Bracklesham beds, and sometimes cut right down to the London Clay. Sand and gravel are convertible terms. He objected to the straight line shown between Chalk and Tertiary beds on one of the sections, and spoke of the danger of drawing sections from data yielded by a few borings. He thanked Mr. Irving for again bringing forward the subject.

The AUTHOR referred to the number of criticisms and the lateness of the hour; most of the points mentioned were dealt with in the paper. He replied to Mr. Whitaker's remarks on the lines in his sections. Having made a special study of the continental literature on the subject, he would stand by his remarks on the humus acids: the action of the humus acids had been of some importance in these and other beds. He had proved that the Diatom-remains noticed by him were not in a living state. It must be understood that this paper was mainly confined to the northern side of the basin. He gave reasons why he had drawn the anticlinal in the Wellington-College section. Referring to certain of the pebble-beds mentioned in his paper, and more especially to the criticisms of Messrs. Monckton and Herries, he insisted upon the pebble-beds at Easthampstead and other points (*e. g.* at Barkham) being in *in situ*. The remarks of one of them showed that he had not mastered what the author had already published on the evidence of well-sections. He further discussed the presence of marine shells in the Middle Bagshots, and said that this was no more inexplicable than the presence of intercalated beds containing marine shells in other fluviatile and terres-

trial groups of strata (*e. g.* the Coal-Measures and the lignitiferous group of the Soissonnais) and in modern deltas.

In many respects the criticisms on his section could only be argued out on the ground. With respect to the clay-series spoken of by Mr. Hudleston, no strong inferences could be drawn from that on the opposite side of the area, even if it were shown to be Lower Bagshot. He admitted that, in places, the Lower Bagshots become more argillaceous, the London Clay having largely contributed to the materials.

29. CONSIDERATIONS *on the DATE, DURATION, and CONDITIONS of the GLACIAL PERIOD, with reference to the ANTIQUITY of MAN.* By JOSEPH PRESTWICH, M.A., F.R.S., Professor of Geology in the University of Oxford. (Read May 25, 1887.)

WHEN, twenty-eight years ago, the barriers which restricted the age of Man to a limited chronology were overthrown by the discoveries in the Valley of the Somme and Brixham Cave, the pent-up current of geological opinion tended to the other extreme of assigning to Man (Post-glacial) an excessive antiquity; and now the belief in that great antiquity seems to me to be exerting, in a manner somewhat similar to that which at first caused the rejection of the Kent's Cave and Somme Valley evidence, an imperceptible bias on the questions raised as to the Glacial and Preglacial age of Man—apart from the question of Pliocene or Miocene Man, into which, on the present occasion, I do not purpose to enter.

The extreme opinions which dealt with millions of years are now probably held by few; but still, with many and, probably, the majority of geologists the Glacial and Postglacial periods, which involve the question of the antiquity of Man, are measured by very great terms of time. At the outset of the discussion, and when the antiquity of Man was limited to the Postglacial period, I saw no reason for assigning to that period the length of time then claimed by many geologists. The data, however, on which to form an opinion with respect to the duration of this and of the Glacial period were too imperfect to form any definite conclusion upon. Since then further observations in the Alps, and more especially the observations of the Danish geologists in Greenland, have brought forward facts of great importance in their bearing on ice-action and growth, and have furnished us with data which may warrant the estimates I now beg to lay before the Society, not as a complete discussion of the subject, but as a preliminary inquiry.

Measured by our own limited experience, the excavation of the Postglacial valleys, the life of the successive generations of the Pleistocene Mammalia, and the dying-out or extinction of a large number of species might seem to demand a long period of time. Consequently at first it was suggested that the Glacial period commenced possibly about a million years since, and that the Postglacial period had lasted about 200,000 years. It was felt, however, on the other hand, that the very large proportion of existing species of Vertebrata and Invertebrata which came in with the Pleistocene period and had since undergone no change, and this combined with the stationary condition of Man himself during so long an interval, presented serious objections to adopting such lengthened periods of time. But on neither side were the conclusions based on any definite data.

The question was in this state when Dr. Croll's attention was

directed to the subject. After careful investigation of existing hypotheses he came to the conclusion that the cold of the Glacial period could not be ascribed to any physiographical changes in the distribution of land and water, but that changes in the eccentricity of the earth's orbit afforded a probable clue to great secular variations of climate, such as would produce glacial epochs. Following up Leverrier's calculations, and assuming that the periods of greatest cold were when the eccentricity rose to a high value, and that the warmer periods occurred during the times of lesser eccentricity, Dr. Croll, by an elaborate mathematical computation, extended the inquiry as to the extent and periods of maximum and minimum eccentricity for 3,000,000 years back and 1,000,000 to come, and showed that within the last million years there have been two such periods of extreme eccentricity—the one extending from 980,000 to about 720,000 years ago, and the other from about 240,000 down to 80,000 years ago*.

As the former period was of greater duration than the latter, and the eccentricity also then attained its highest value, Dr. Croll was at first disposed to refer the Glacial epoch proper to that period, and to consider the latter as corresponding with the extension of the local glaciers towards the close of the Glacial epoch. On this point he states that he "consulted several eminent geologists, and they all agreed in referring the Glacial epoch to the former period," the reason assigned being that they considered the latter period to be much too recent and of too short duration to represent that epoch.

Dr. Croll therefore had good warrant that he was well within the limits of geological probabilities when, on a reconsideration of the subject, he came to the conclusion that the Glacial epoch must be referred, not to the first-named period of eccentricity, but to the later one, commencing 240,000 years ago; and this is a date now very generally accepted. He considered that "the modern and philosophic doctrine of uniformity had led geologists to over-estimate the length of geological periods" (p. 325). Nevertheless he assumes that "the present rate of subaerial denudation does not differ greatly from that which has obtained since the close of the Glacial epoch" (p. 338), and proceeds with the argument in accordance with this view, taking the rate of denudation to be one foot of soil removed from the surface in 6000 years—an estimate founded upon the quantity of sediment now carried down to the sea by such rivers as the Mississippi, the Rhine, the Rhone, the Ganges, &c. This is, in fact (notwithstanding the qualification just admitted), applying the results of experience in recent times to facts observable in climates where the meteorological phenomena were totally different, and the conditions therefore not analogous. Consequently the data cannot be rightly applicable. If used at all, as a sort of base-line, it must be with modifications, such as taking the modern data as the known quantity, and adding an unknown quantity "*x*," which quantity has to be determined before we can get at the true rate of denudation during the period

* 'Climate and Time,' chapter xix. (1875).

under inquiry. Some of the objections which have occurred to me against comparing the present rate of denudation with that of past times and the Glacial period I have given elsewhere *, so need not repeat them here. Nor is it my intention to discuss Dr. Croll's theory upon his own special grounds, which he has argued with infinite ingenuity and presented in so attractive a form that, as I am well aware, it has carried conviction to a large number of geologists. That the causes he assigns have considerable value, there can, I think, be little doubt, and they may have an important bearing upon certain geological problems, such as relate to those minor periods of low temperatures with which we are all acquainted, as, for example, that which seems in early Eocene times to have affected the marine fauna of the Thanet Sands and the flora of Gelinden; but that they are sufficient to account for the extreme cold of the Glacial period is open to question. There are, as he himself observes, astronomers and physicists who are of opinion that the climate of the globe could never have been seriously affected by changes in the eccentricity of its orbit. The point has been contested by Professor Newcomb, the Rev. E. Hill, and others, whose papers and Dr. Croll's rejoinders should be consulted †.

If the cold were due to this cause, how is it that, whilst the lesser eccentricity of 240,000—80,000 years ago resulted in the intense Glacial epoch of the Pleistocene period, the effects of the greater and longer eccentricity of 980,000—720,000 years ago, which should surely have resulted in a still more intense glacial period, has not left its traces in anterior geological series. But there is no such evidence even in the later Tertiary period.

It is, however, not only on the question of the efficiency of the hypothesis to account for the facts, a point which I would leave to astronomers and physicists to decide upon, but on the geological question whether the necessary concordance exists between the observed phenomena and the phenomena as they should be were we to accept Dr. Croll's views, that we should judge of its applicability. If we adopt the hypothesis it should follow:—

- 1st. That at intervals during all geological time there would be some periods during which a recurrence of similar glacial conditions took place.
- 2nd. That interglacial conditions would affect each pole alternately, and that there should be in both hemispheres a succession of warm interglacial periods.
- 3rd. That the commencement of the Glacial epoch should be placed about 240,000 years back, and have a duration of 160,000 years; after this the amelioration of the climate to its present condition, which involves a Postglacial period of about 80,000 years.
- 4th. That the age assigned to Palæolithic Man, even if limited to

* 'Geology,' vol. i. chapter vi.

† Various papers in the 'American Journal of Science,' 'Philosophical Magazine,' and 'Geological Magazine,' from 1876 to 1884.

Postglacial times, could not be less than 80,000, whilst, if carried back to Preglacial times, it would necessitate an antiquity of 200,000 to 300,000 years.

With regard to the first point, Dr. Croll shows that in the three million years for which his tables are computed there were five periods during which the eccentricity was as great as or greater than during the Glacial epoch proper; so that, taking geological time at the hundred million years, at which he estimates it, there should have been in all probability some 165 such periods of cold. With the exception of the Permian, which is still "*pendente lite*," where is there evidence of any such cold periods?

Dr. Croll does not overlook this difficulty, and contends that in the Italian Alps there is strong evidence in favour of the opinion that glacial conditions existed there during the Miocene period. This, he informs us, is stated on the evidence of two distinguished geologists; but the fact of the Miocene date of the beds in question has never since been confirmed; all the later evidence tends to show that it was not until towards the close of the Pliocene period that glacial conditions set in. At the same time he admits the existence of warm conditions, as undoubtedly proved by the flora, in Greenland during Miocene times.

For the Eocene period Dr. Croll relies on another Alpine case—the coarse conglomerates with some enormous blocks forming the Flysch. But this was a period of Alpine disturbance and change, when, though the rocks may have been rent and worn down in the mountain area, the marine life at a short distance gives evident indications of a high general temperature: Nummulites then abounded in the surrounding seas, together with Echinoderms of a decidedly tropical aspect.

The case for the Chalk is still weaker, for the very few and exceptional foreign rock-boulders that have been found in it are of small size, such as might have been carried in the roots of trees or by seaweeds, or possibly by small winter ice-rafts from the mountains of Scandinavia or the Ardennes, whilst all the life of the Cretaceous sea is strictly that of temperate, if not of warm, latitudes. The small pebbles may have been carried by the large marine reptiles.

It is on facts of the same character as those which Dr. Croll adduces for the Eocene period that he would found evidence of the action of ice in Scotland during the Oolitic period; but we must seek for some other explanation to account for the dispersion of the conglomerates and boulders in face of the incompatible fact that at those times warm conditions of climate extended to 70°–80° North, and that corals, Cephalopods, and huge reptiles swarmed in the seas.

The climatal conditions during the Permian period may be open to doubt; but on this yet unsettled point it is not necessary here to enter. If admitted, it would not affect the general question.

Nor is it easy to admit a claim for ice-action during Carboniferous times when the luxuriant vegetation of the Coal-measures flourished

not only here but on Bear Island and other northern lands. With respect to the blocks of granite alluded to as occupying the lower beds of the Coal-measures in France, they may be, like the Tors of Cornwall, blocks left *in situ* from the decomposition of the granite on which the Coal-measures there rest, or they may be boulders washed down at that period by the torrents from the adjacent granitic mountains. Other foreign pebbles may be accounted for as we have accounted for those in the Chalk.

There are similar palæontological objections to ice-action in the Devonian and Silurian periods. Although there may be at times instances in which the blocks show striæ and are derived from rocks not known in the locality, it must be borne in mind that such striated masses may be fragments of slickenside surfaces in the rocks from which the breccias are derived; and that, although a particular rock may no longer show in the locality, it may exist there buried beneath newer deposits, as, amongst others, in the case of the granite of the Ardennes, which, although formerly unknown there, was met with in a railway-cutting beneath a slight covering of Palæozoic rocks.

Admitting the imperfection of the geological record, it is evident that, as a whole, the physical instances fail entirely to supply any sufficient corroborative evidence, either in force or in number, to support the theory of recurrent Glacial periods. Surely out of 165 or even 100 cases, more definite marks would have been left, especially in the more recent periods, such as the Pliocene and Miocene, when the land had assumed many of its present contours.

With respect to the second point, Dr. Croll states that "the Glacial epoch may be considered as contemporaneous in both hemispheres. But the epoch consisted of a succession of cold and warm periods, the cold periods of one hemisphere coinciding with the warm periods of the other, and *vice versâ*" (p. 234). This would involve an indefinite succession of interglacial periods; but only one definite interglacial period during the Glacial epoch is brought forward. Dr. Croll, however, accounts for this on the grounds that "the geological evidences of the cold periods remain in a remarkably perfect state, whilst the evidences of the warm periods have to a great extent disappeared" (p. 238). If, however, one instance could be well preserved, might we not expect other instances to occur in some of the many localities affected? Dr. Croll estimates the average duration of a warm period at about 10,000 years. Supposing such to have been the case, the phenomena of the glacial series certainly afford no corroboration of the remarkable vicissitudes of climate this would infer.

There are, it is true, indications both in Britain and Switzerland of intervals of milder conditions during certain times of the Glacial epoch; but these minor differences are, I think, due, not to the cosmical cause of Dr. Croll, but to those changes of climate that may be brought about by differences in the distribution of land and water, such, for example, as the extensive submergence which took place in England and North Germany after the first great land-glaciation,

when there was a submergence of from 1500 to 2000 feet, and a large land-area became covered by the sea—a change which could hardly have failed to affect the climate not only of those regions, but also of Switzerland and other parts of Europe. It is not my intention, however, to say more at present upon this question, but to proceed to the consideration of the third and main point, namely, the probable duration of the Glacial epoch, which hinges so materially on the laws affecting ice-growth and glacier-motion.

Twenty years ago the only data we had bearing on the subject of glacier-motion and action were the observations of Agassiz, Forbes, Tyndall, and others on the glaciers of the Alps. These had taught us the rate of motion of many of the Alpine glaciers, their periods of advance, and the causes of their growth and decay. It was on these facts alone, which are really not applicable, that we had to judge what might have been the possible rate at which the great ice-sheet spread over the land.

It was found that in July the Mer de Glace advanced at the rate of 33 inches in the twenty-four hours, and the Aletsch glacier 19 inches in August; whilst the winter rate was estimated at about half that of summer; so that roughly the rate of motion for the year may lie between 300 and 400 feet, though in one year the Mer de Glace was found to have advanced 483 feet.

The position of Hugi's hut on the Aar glacier gave a more definite measure based on a longer average, for in the course of fourteen years it was found to have been carried at the mean rate of 338 feet annually. We may therefore take the average motion of the Swiss glaciers to be about equal to 300 or 400 feet annually.

The advance and retreat of the terminal front of a glacier are of course independent of this continuous motion of the great body of ice, and depend on the climatal conditions of the year. In the cold summers of 1816 and 1817 there was a general advance of all the Swiss glaciers, whilst since 1856 there has been a general retreat. Usually the loss or gain is small, but in some years it is considerable. In the two years above named some of the glaciers advanced from 100 to 150 feet or more. Of other Swiss glaciers an advance of 1 mètre daily in summer is recorded; but the most remarkable case is that of the Vernagt glacier in the Tyrolese Alps, which is exceptional in that it advances by fits and starts. Between 1843 and 1847 the ice from this glacier covered the valley below to the length of 1264 mètres, which gives a mean annual rate of 870 feet, while the thickness of the mass of ice near its extremity exceeded 500 feet. Another glacier in the same range advanced after all oscillations above a mile in a century. On the other hand the Rhone glacier between 1856 and 1877 retreated nearly half a mile, or on an average 116 feet annually; whilst between 1870 and 1877 the retreat extended for a distance of 400 mètres, or a mean of 187 feet per annum, the greatest retreat being between the years 1870 and 1874, when it amounted to 250 mètres, or a mean of 205 feet per annum. In the Valley of Chamouni the Glacier du Tour retreated 320 mètres in the eleven years between

1854 and 1865, or at the rate of about 155 feet annually. The mean annual ablation of the Swiss glaciers is estimated at about 10 feet, but on the Glacier des Bossons the surface of the ice has been lowered 260 feet in twelve years.

Here, then, seasonal fluctuations alone are attended by alternate advances and retreats of the glacier-front of not less, on a mean of these instances, than from 200 to 300 feet per annum. If, then, mere seasonal fluctuations are attended by changes of this extent, it would follow that with the secular increase of cold during the Glacial epoch the rate of progress must have considerably exceeded these limits. Taking for the present a mean rate of 250 feet, the longest of the old Swiss glaciers, namely that of the Rhone, which then had a length of 250 miles, might have travelled that distance in 5000 years. This, however, is assuming the absence of seasonal retardations and fluctuations, which is not possible. Allowances have to be made for warmer seasons and temporary retreats of the ice, and also for the fact that the old glacier did not move on the steep inclines of Alpine valleys, but traversed the small incline of a great river-plain. On the other hand, we have to take into account the circumstance that the present seasonal changes give measure of the growth of ice under the continuous and more extreme glacial conditions of that epoch. Nothing positive can therefore be founded on this case, though it may serve to show the possibility of a more rapid rate of progress of the old glaciers than the present estimates allow.

We have, however, in Arctic regions truer and more adequate terms of comparison in the great ice-sheet of Greenland. Already in 1876 Professor Helland* showed that the Greenland glaciers had a much more rapid rate of flow than those of Switzerland. The Jakobshavn glacier, notwithstanding its small slope of only half a degree, was found to advance its front at the rate of from 50 to 60 feet a day. The flow of the glacier of the Fjord of Torsukatak, which is nearly five miles broad, gave a rate of from 12 to 33 feet daily. Taking the average rate of the three glaciers on which Prof. Helland made observations, the average discharge of the ice was 23 feet in twenty-four hours; and he estimated that at the Jakobshavn glacier only four years would be required to transport a mass from the edge of the inland ice to the sea, a distance of $12\frac{1}{2}$ miles. But he considered it improbable that the inland ice would move with anything like the velocity of the glaciers, and calculated that a mass of ice starting halfway between the east and west coasts of Greenland would take eighty-one years to reach the Fjord. These observations were, however, made in the summer months, and were only of a few days' duration, so that the annual rate was not ascertained.

Since then a Danish scientific expedition, consisting of engineers and geologists (one of whom, Mr. K. J. v. Steenstrup, passed eight summers and two winters in the country), have completed a most important exploration of the Greenland ice, of which a short sum-

* Quart. Journ. Geol. Soc. vol. xxxiii. p. 142.

mary has recently been given by Dr. Rink*. Their observations fully confirm those of Professor Helland, and show that the motion of the inland ice may be compared to an inundation. It was found that there is a general movement of the whole mass of the ice from the central regions towards the sea, and that it concentrates its force upon comparatively few points in the most extraordinary degree. These points are represented by the so-called ice-fjords, through which the annual surplus of ice is carried off and discharged in the shape of icebergs.

The velocity of the ice was noted in seventeen glaciers, the measurements being repeated during the coldest and the warmest seasons; and it was found, remarkable as it may seem, that the movement was not materially influenced by the seasons. The great glacier of the ice-fjord of Jakobshavn, which has a breadth of 4500 mètres, was rated at 50 feet per diem. One of the glaciers in the ice-fjord of Torsukatak has a movement of between 16 and 32 feet daily. The large Karajak glacier, about 7000 mètres broad, proceeds at the rate of from 22 to 38 feet in twenty-four hours; and another in the fjord of Jtivdiarsuk, 5800 mètres broad, at from 24 to 46 feet. The conclusion at which the Danish corps arrived was that the glaciers which produce the bergs move at the extraordinary rate of from 30 to 50 feet per diem throughout the year.

What, then, may have been the rate of movement of the great ice-sheets of America and Europe in the Glacial epoch? No doubt the velocity of the ice in the ice-fjords is increased by the free play of the ice as it reaches the sea and by the rapidity with which the bergs are detached. It is also increased by the circumstance that the great body of inland ice, the whole of which is in motion, is forced, and has to escape, through the passes between the range of mountains which fringe the coast and rise high above the immediately inland districts. The summits of those mountains rise in bare isolated masses (Nunataks) above the surrounding ice-sheet, and the passes between them and through which the ice has forced its way have been gradually worn down, and now form the channels (fjords) through which the surplus inland ice escapes, with a velocity increased in proportion to the contraction of the passages. Thus in the ice-fjord of Torsukatak, which is nearly 5 miles wide, the ice passes out with a mean velocity of 24 feet per diem, or equal to a mass of ice of that width, and $1\frac{3}{4}$ mile long, annually; the Karajak glacier, which is $4\frac{1}{2}$ miles broad, flows at the rate of 30 feet daily, or equal to a length of above 2 miles a year; and in the huge ice-fjord of Jakobshavn, which is not quite 3 miles broad, the ice attains a velocity of 50 feet daily, so that a length of above 3 miles of ice is discharged annually.

Until all the glaciers have been gauged, and we know the relation of their totals to the breadths of the intervening "Nunataks," no definite measure of the total volume of annual surplus ice can be established; but for our general purpose some approximate idea may be formed. The average of the great glaciers gives a mean rate

* Trans. Edinb. Geol. Soc. vol. v. p. 286 (1887).

of 35 feet daily and a discharge of $2\frac{1}{5}$ miles of ice annually. There are other ice-fjords of far greater breadth than those, such as the Humboldt glacier, which is 60 miles broad. Looking at the map, it seems not improbable that the breadth of ice-front to rock-front of the whole coast may be in the proportion of 1 to 20.

Supposing the quantity which runs off to be equalized throughout the whole extent of coast, the fringe of ice which would pass off from the land would be $\frac{1}{5}$ of a mile in width annually, or a breadth of 1 mile would take eight years to pass off. If the proportion should prove greater, say 1:30, then it would take twelve years. In the one case a sheet of ice 100 miles long and of the width of the central ridge would require eight hundred, and in the other twelve hundred years for its formation; or, taking the length of the maximum radius of the old ice-sheets, of which the Canadian highlands and the Scandinavian mountains formed the centre, at 500 miles, the time required to form this length of ice would be respectively four thousand and six thousand years.

This, however, is based only on one roughly approximate known quantity. We have, on the *per contra* side, to allow for certain unknown quantities. First, allowance has to be made for the difference between the free escape into the sea and the impeded progress of ice over land with slight gradients. This resistance would, however, be partly neutralized by the gradual building up of a great thickness of ice in the central area, where in the Glacial epoch it attained a thickness of from 5000 to 6000 feet*.

The mass of ice, projected outwards towards its circumference, would, except where it met with contracted channels, roll over the land as a viscid body with comparatively little rigidity and friction. When, in the Glacial epoch, the great southern glaciers of the Alps flowed down the steep and confined valleys opening upon the flat plain of Lombardy, they deeply ploughed their channels, and pushed before them for short distances enormous moraines; but in the wide open tracts of the United States, of Northern Europe, and the south of England, where the ice met with little resistance and could expand in other directions, there is, as a rule, an absence of moraines and often of glacial striæ.

In the second place, there were, no doubt, seasonal fluctuations which would retard the flow for lesser or greater periods. It is asserted that in Europe there were interglacial periods during which the ice disappeared from the surface for great lengths of time. But either the evidence is insufficient or it points to slight temporary effects, except in one case, which is of more importance, and on which the greatest stress is laid, namely, that of Dürnten in Switzerland. There beds of lignite with mammalian remains are intercalated between two glacial deposits. Admitting the fact that the lignite rests on beds of undoubted glacial (ground-moraine) origin, and that the trees grew on the spot where their stumps and remains are found, it by no means follows, as contended, that because these trees are all

* The American geologists also consider that the Canadian land then stood considerably higher than now.

of species now living in Switzerland the temperature was that of Switzerland at the present day. *Pinus sylvestris*, *Abies excelsa*, the Yew, the Birch, and the Oak flourish equally in Sweden and far north in Siberia. On the other hand, there is one species of *Pinus* (*P. montana*) which is spread over the mountain country up to heights of 7000 feet, and is rare in the low lands; while one of the mosses is closely allied to a species now growing on the hills of Lapland. The few species of Mammalia have a distinctly northern facies. *Elephas primigenius*, *E. antiquus*, *Ursus spelæus*, as also *Cervus elaphus* and *Bos primigenius* are commonly associated with the Reindeer, Musk-Ox, and other Arctic animals of the cold Postglacial times. Further, both the trees and animals are those of our "Forest-bed," the last land-survival before the setting in of the extreme Glacial cold.

Is the return, therefore, of the retreating glacier, supposing the boulder-gravel above the lignites of Dürnten to be due to direct ice-action, to be ascribed to anything more than a comparatively slight temporary change of climate, like those that now for a succession of seasons cause, from time to time, a temporary advance of the glaciers, only more marked? We must allow, of course, for greater differences and longer intervals of time than now obtain.

Such minor vicissitudes of climate are more compatible with changes in the physiography of Europe than with the cosmical causes to which the Glacial epoch, as a whole, was, there is little doubt, due. Nor is it difficult to find such a cause in the extensive changes in the distribution of land and water which took place in Britain and Northern Europe after the first great land-glaciation and the formation of the Lower Boulder-clay. The submergence of Ireland, Wales, Scotland, and England (in part), and of a large area in Russia and North Germany, extending to Holland, was sufficient, with the influence of currents from the south (for in the shells of the Middle Boulder-series there is a large percentage of southern forms and an absence of extreme Arctic forms), to effect a considerable amelioration of the climate, such as would lead to the temporary return of the old Preglacial, but still northern, fauna and flora.

With the rise of the temporarily submerged lands the climate again changed, and brought the Alpine glaciers back over part of their old ground, overwhelming in their course the forest-growth which had sprung up in the meantime. But the beds of stratified sand, gravel, and boulders overlying the lignite are more likely to have been the result of glacial torrents than of the direct superposition of the ice, which may have again approached, but is not proved to have covered, the spot.

For the formation of this interglacial bed a period of 6000 years has been claimed; but the claim rests on doubtful data. The lignite is from 5 to 10, and rarely 12 feet thick. In the estimate the maximum thickness of 12 feet is taken, and it is assumed that to form this 12 feet of lignite it would have required 60 feet of peaty matter, or that it took 5 feet of peat to form 1 foot of lignite, and that 100 years would be needed for the growth of each foot of peat: thus a total of

6000 years is obtained. But the growth of peat varies extremely. It may be, in some cases, not more than 1 foot in a century, but it is commonly more, being sometimes as much as 4, 5, and even 10 feet in that time; and while it is estimated that to form 1 foot of coal, from $2\frac{1}{2}$ to 3 feet of woody matter may be required, it is clear that lignite, which has lost less of its original constituents* than coal, and of which the specific gravity is about 1.25, while that of coal is about 1.5, cannot require for each foot 5 feet of peat and wood. Taking, therefore, the original thickness of the peat at 24 instead of 60 feet, and the growth at 4 feet in a century, 600 years, instead of 6000, would be sufficient for the formation of the Dürnten beds.

These intervals, therefore, although they may involve considerations respecting hundreds, are scarcely likely, as they must have been subordinate to the general progress of the ice-sheet, to involve questions relating to thousands of years. It is to be observed also that there is no evidence in North America of an interglacial period in the sense of the one supposed to have existed in Europe, although there is evidence that after the great ice-sheet had retreated for a very considerable distance northward, there was a pause or a partial advance again southward—an advance marked this time by deeply lobed lines of moraines.

Whilst there are these reasons for prolonging the duration of the Glacial epoch, there are other factors in the question which tend to shorten it. At present the discharge of ice from the Greenland sheet is merely the surplus under conditions of a settled mean annual temperature; but the Glacial epoch was a time, on the whole, although there may have been pauses, of constantly increasing cold, and of constant increase in the area of the great ice-sheet, and therefore there was not merely a supply due to a uniform mean annual temperature, but the increments arising from the gradual secular refrigeration.

It may also be a question whether or not the rainfall was then greater than now. At present in Greenland it is small, apparently under 20 inches, while in the North-American old ice-area it is not less than from 40 to 45 inches annually. Possibly the precipitation in the Glacial epoch was even larger, for the Florida promontory, which now deflects and contracts the Gulf-stream, was at that time considerably smaller, the coral reef by which it is formed not having then extended so far south. Consequently the channel through which the stream passed being wider, a greater volume of water flowed through; and this large body, thus carried into the North Atlantic, moving probably with greater velocity and having a higher temperature than now, may, in consequence of the greater saturation of the incumbent air, have materially affected the precipitation

* In the extreme case of the conversion of wood and peat into anthracite, in which the proportion of oxygen and hydrogen to the carbon is as 5 : 95, the estimate is of from 7 to 8 feet of wood to 1 foot of anthracite; and in ordinary coal, where these constituents are roughly as 15 : 85, the estimates vary from $2\frac{1}{2}$ to 3 feet of woody matter to 1 foot of coal. In lignite, then, where the change has involved less loss (say to 30 O + H : 70 C) and the pressure has been less, the compression must certainly have also been less.

both in North-eastern America and North-western Europe. It is therefore more than possible that the mean annual surplus of ice was, independently of the extra quantity due to the increasing cold, larger than in Greenland at present.

The growth of the ice-sheet is not, however, dependent only on the rainfall. The experiments of MM. Dufour and Forel have shown that when the temperature of the air on the Rhone glacier varied from 41° to 52° F. there was a condensation of moisture equal to 150 cubic mètres of water per square kilomètre, and this increased proportionally the volume of the glacier-ice and water. Under these circumstances it is not difficult to conceive that a foot or more, taking the total precipitation, might be added annually to the thickness of the ice. Even in recent times a difference of level in the surface of some of the Swiss glaciers to the extent of from 80 to 100 feet has been known to have been effected in the course of 20 years.

Taking as the known quantity the results supplied by the Greenland observations, the equation will be—a surplus-ice overflow equal to one mile advance in eight or twelve years, minus the retardation due, 1st, to friction and irregularities of surface; 2ndly, to seasonal changes of temperature (the so-called interglacial periods); plus, 1st, the increase of discharge due to progressive secular refrigeration, and 2ndly, the increased precipitation and condensation. The one known quantity gives from 4000 to 6000 years. Of the unknown quantities we can at present but form a distant idea. We can only feel assured that they must, in all probability, be subordinate to the known quantity. After full consideration of the subject, my own opinion, based on the facts I have here brought forward, is, that it will be found that the time required for the formation and spread of the great ice-sheets in Europe and America need not be extended beyond from 15,000 to 25,000 years, if so much.

I am taking this to represent the interval between the time when the ice-sheet commenced its progressive march and that when the climatal change was such as to cause its full retreat. The fact is, as we use the terms, they have not the meaning that might be attached to them. Preglacial does not signify a separate period before the Glacial, nor Postglacial another subsequent to it. The former term merely applies to the earlier stages of the Glacial epoch, and the latter to the later stages. The lines are arbitrary ones. We might equally well adopt two periods, the one from the inset of the cold period to its zenith, and the other from its zenith to its termination. I, however, here adopt the usual divisions—the so-called Glacial epoch representing a certain length of time when the cold was at its maximum, and the others the periods of first increase and last decrease. It is to the latter, to which, on Dr. Croll's hypothesis, a term of 80,000 years has been assigned, that I now refer.

The adoption of this length of time has been very much the result of the belief that no shorter time would account for the excavation of the valleys supposed to have been formed during this period. I myself may have been partly instrumental in giving currency to the

belief, for I placed the oldest of the old valley-gravels at the commencement of this Postglacial period, whereas I now think it probable that in the south of England and in France many of them may date back to full Glacial times. I could never, however, agree to the great length of time assigned to the postglacial period. The adoption of a rate of denudation based on that of the present day always seemed to me open to grave objections, and in this belief all subsequent experience has confirmed me. Dr. Croll, who, with others, adopts the generally accepted rate of denudation, namely, one foot of rock or soil removed off the general level of the country during 6000 years, nevertheless remarks "if the rate of denudation be at present so great, what must it have been during the Glacial epoch? It must have been something enormous." This led him, it is true, to reject the alternative date of from 980,000 to 720,000 years ago for the Glacial epoch, and to adopt the one terminating 80,000 years ago; yet much of his argument is based on the assumption of the above-named rate of denudation*.

But it is no more possible to judge of the rate of denudation during the Glacial period by that of river-action at the present day than it was to estimate the rate of flow of the Greenland ice by Alpine experience. The enormous pressure and wear of ice from 2000 to 6000 feet thick in contracted valley-channels, especially in fiords, where, as for example in Greenland, it stood from 1800 to 2000 feet higher than now; the powerful disintegrating effects of extreme cold on rocks; the annual action of ground-ice in rivers, and of the sweeping and devastating floods, resulting from the melting of the winter's snow and surplus ice, combined to produce results of which it is impossible to judge by the ordinary work of these temperate latitudes. We must go to high northern latitudes to find any terms of comparison.

I am unable at present to go more fully into this subject, but I would just allude to some interesting corroborative testimony recently brought forward by Prof. J. D. Dana in connexion with the phenomena of the Connecticut valley †. The numerous old river-terraces in this valley extend for a distance of 250 miles inland. The river has excavated a valley through the ancient high-level plain to a depth of from 150 to 200 feet, with a width of from one eighth of a mile to one mile. The mean depth of the river in flood at this Postglacial (Champlain) period is estimated by Dana to have been about 140 feet ‡, the mean height of the present floods being about 26 feet. The mean width of the upper section of the flooded stream he estimates at 6000 feet. Taking these measures, together with the mean slope, he obtains a maximum velocity of over twelve miles an hour, with a mean of about three or four miles, whence some idea may be formed of the enormous transporting power of the river of that period. The annual rainfall in

* Though little change has yet been made in the line of argument, there has been a growing belief amongst geologists that the present rate of change has not always been uniform, and must not be taken as the measure for all past and all future time. See some pregnant observations on this point by Dr. Archibald Geikie in the *Trans. Geol. Soc. Glasgow* for March 1868, p. 188.

† *American Journ. of Science* for March 1882.

‡ This seems to me possibly too extreme a depth.

this district now varies from 65 inches on the coast to 42 inches in the interior; but during the Glacial period, Dana considers that the special conditions must have occasioned a much more abundant precipitation—probably as high as 120 inches, or greater than in any modern glacial region.

In this country and in the north of France the valleys have been excavated to the depth of from 80 to 120 feet in glacial and postglacial times. It may be difficult from our present experience to conceive this to have been effected in a comparatively short geological time, though the extension back to glacial time gives both greater power and greater time; yet it is equally, and to my mind more, difficult to suppose that Man could have existed 80,000 years (or 200,000, if Preglacial), and that existing forms of our fauna and flora should have survived during 240,000 years without change and modification. The acceptance of those dates, which place the land-glaciation some 100,000 to 150,000 years back, would also lead to the difficulty (even on the assumption of a rate of denudation of 1 foot in 6000 years)* that the surface-wear should have been far greater than it is. For example, to mention only two points, could the striations on soluble rock-surfaces have remained so fresh as they are, and would not the limestone-rock on which the boulders of Silurian rocks were left on the melting of the ice on the Yorkshire hills show much greater wear than it actually does? These boulders now stand on pedestals raised from 1 to 2 feet above the surrounding surface-level in consequence of the dissolving away of the limestone rocks. We should look for pedestals of much greater height if the glaciation took place at the distant period involved in Dr. Croll's hypothesis.

My first impressions with respect to the Valley of the Somme were:—that the high-level gravels originated in early Glacial times; that the intermediate stages and terraces were formed during the excavation of the valley as a consequence of the great glacial and postglacial floods; and that the low-level gravels formed the concluding stage of those conditions. But in the absence of data, since acquired, the strong prepossessions then existing, and the novelty of the subject, I was then led to conclude that the whole might be Postglacial.

So much evidence has, however, since been brought forward with respect to the so-called Preglacial Man, that I feel I am now justified in reverting in great part to my original position. The cave-work of Mr. Tiddeman and Dr. Hicks gives strong presumptive evidence of the earlier geological appearance of Man in the British area; and I see no reason to doubt the sub-boulder-clay evidence of Mr. Skertchly, although I was unable myself to corroborate his discovery of the worked flints. Of the correctness of his opinion in respect to the stratigraphical position of the bed in which his specimen was found, I have, however, little doubt. The great masses of gravel in the neighbourhood of Mildenhall and Lakenheath, also containing flint implements, are certainly not of fluvial origin; they seem

* A general rate of this description is also scarcely applicable to a special rate, such as that relating to valley-denudation.

to me to be part of the phenomena connected with the passage of the great ice-sheet over the eastern counties, and in that sense Preglacial. I hope, when more at leisure, to be able to give other instances.

In the meantime, I may briefly state my conclusions that the high-level beds of the Somme Valley at Amiens, of the Seine in the neighbourhood of Paris, of the Thames at the Reculvers, and of the Avon at Salisbury, together with the caves above named, date back to Glacial or Preglacial times, not in the sense of being anterior to the Glacial epoch, but in the sense of belonging to that part of the Glacial epoch when the great ice-sheet was advancing, but had not yet invaded the whole of this area. The ice-flood does not, however, seem to have extended to the Somme and Seine Valleys, and there Man, driven back from more northern latitudes, remained in occupation possibly during the climax of the Glacial epoch, after which he returned to the old ground he had previously occupied, and has left further traces of his presence in the lower drifts of the Valley of the Thames and of other rivers of England, and in the caves of Cresswell and other districts. Man was therefore "Preglacial" in one sense, but should, I think, in another sense, be more correctly termed "Glacial" or "Midglacial," inasmuch as it was during the advance of the ice-flood, and only shortly before the land was overwhelmed by it, that he occupied the ground.

In supposing that Man was present in this part of Europe in Glacial times, I am, however, far from claiming for him the antiquity which a term of 80,000 years would give to Postglacial Man, as usually understood. For the reasons before given, I believe that the Glacial epoch—that is to say, the epoch of extreme cold—may come within the limits of from 15,000 to 25,000 years, and, for reasons just named, that of the so-called Postglacial period, or of the melting away of the ice-sheet, to within from 8000 to 10,000 years. This might give to Palæolithic Man, supposing him to be of so-called Preglacial age, if we may be allowed to form a rough approximate limit on data yet very insufficient and subject to correction, no greater antiquity than perhaps about from 20,000 to 30,000 years; while, should he be restricted to the so-called Postglacial period, his antiquity need not go further back than from 10,000 to 15,000 years before the time of Neolithic Man.

Looking at the facts before mentioned—that most of the species of our existing land- and marine fauna and flora appeared in true preglacial time, that is to say, in the time of the Forest-bed group, and were the same as now; that the great extinct Mammalia of that time have left no descendants, but have merely died out as a consequence of the great changes of climate and conditions; and the difficulty of conceiving that Man could have existed for a period, say, of 200,000 years without change and without progress—looking, I say, at these facts, it seems to me that a shorter estimate of time is the only one in accordance with all the conditions of the problem.

This view of the question also brings the geological and ethnological data into closer relationship. Palæolithic Man in north-western

Europe disappeared with the valley-gravels. With the alluvial and peat-beds Neolithic Man appeared, after an unascertained but not necessarily a very long interval, geologically speaking. In Europe we are unable to carry back his presence beyond a period of from 3000 to 4000 years B.C. But already in Egypt, and now in Asia Minor, it is proved that civilized communities and large States flourished before 4000 B.C. Civilized Man must therefore have had a far higher antiquity in those countries, and probably in Southern Asia, than those 4000 or 5000 years; so that it is possible that the two periods may have overlapped in Europe and in Asia, and that while Man in a more advanced state flourished in the East, he may here in the West have been in one of his later Postglacial stages.

DISCUSSION.

The PRESIDENT welcomed Prof. Prestwich back again, and said that he had been greatly missed whilst engaged in other work, for the result of which all were looking anxiously. The paper was calculated to arouse an animated discussion. Prof. Prestwich had only noticed the geological objections to Dr. Croll's hypothesis. The investigations of the Danish geologists in Greenland afforded valuable new data. One most important point for consideration was the age of the valley-gravels in England and Northern France, which Prof. Prestwich had so ably treated.

Dr. EVANS regretted that he had to differ from the Author, and commented on the boldness of giving numerical estimates of geological time. It was questionable whether the astronomical calculations were quite complete. Considering the deposits formed since the Glacial epoch, both marine and fluviatile, he doubted whether the dates assigned by the Author sufficed. Increased rainfall might account for some of the denudation, but the amount could not have been immensely excessive or animal life would have suffered more than it did. Marine erosion told a similar story to fluviatile, as in the case of the southern part of what must have been the old valley of the Solent, which must surely have required more than 10,000 or 12,000 years to remove. Still the ordinary views of extent of time might be exaggerated. The speaker could not accept as conclusive the evidence of the preglacial age of man in Wales, and was very doubtful whether the palæolithic implements found by Mr. Skertchly were in beds of glacial date. Some of the palæolithic implements in the Eastern districts were made from pebbles brought into the country by glacial action, and it was incredible that any implements of really preglacial age should be of the same type. Preglacial man might, however, have lived in other parts of the world.

Dr. GEIKIE remarked that Sir W. Thomson originally had allowed 100 millions of years geological time, and it was on this estimate that Dr. Croll's views were founded. Now, however, Dr. Thomson had limited geological time to about 12,000,000 years. The speaker

doubted whether this could have sufficed for the known course of geological events. He wished to know the data on which Prof. Prestwich's estimates of time were founded. It had been suggested that the upper valley-gravels might be due to the melting of the ice-sheets and not to rivers at all.

Prof. BOYD DAWKINS also questioned the figures. There are no standards for measuring time in terms of years outside history, in which not only the sequence of events is recorded, but the length of the intervals between them. In geological time we are dealing with a sequence of events separated from one another by intervals, of neither of which have we any certain measure. Dr. Croll's theory is based on the assumption that the Glacial climate was produced by a change in the relation of the earth to the sun. There is no evidence of this. Nor are natural chronometers to be found in the variable rate of valley-erosion, or of the deposit of alluvium, or of the retrocession of waterfalls. Nor do Sir W. Thomson's varying estimates of past time (ranging from twelve to three hundred millions of years) help us. The antiquity of man can only be measured by the changes which have taken place in geography, in climate, and in fauna, which have been very great. The strata with palæolithic implements in Algiers, Egypt, Palestine, and the Dekhan have not as yet been brought into relation with the Glacial period.

Dr. HICKS remarked that Prof. Prestwich, in giving reduced estimates of geological time, must have been desirous of converting some who seemed still unwilling to accept the evidence obtained, bearing on the preglacial age of man, apparently mainly because of the exaggerated amount of time given to the Glacial period by some authors. The evidence as to rapidity of motion of ice in Greenland tended to shorten the necessary duration of the Glacial period. He invited Dr. Evans and all Fellows to be present at the new excavations in Wales, which were to be commenced on the 6th June. He described the situation in which the remains of man, claimed to be of Glacial age and probably Preglacial, had been found, and explained the line of investigation about to be adopted.

Mr. DE RANCE stated that he fully agreed with Dr. Hicks in his interpretation of the facts observed by him.

Mr. J. ALLEN BROWN, after thanking Prof. Prestwich and Dr. Evans for their contributions to the discussion of this question, proceeded to notice the results of his own researches in the Thames Valley, and especially in the neighbourhood of Ealing, which indicated, he thought, that a lapse of time incalculably vast must have been required for the production of the observed phenomena.

Mr. TIDDEMAN said that the evidence as to the rapidity of motion of the Greenland ice-sheet was most important. He did not think we could safely take the erosion of the limestone around the perched Norber boulders as a measure of time elapsed since the ice-sheet, because much glacial rubbish may have been removed before the surface of the rock was exposed to weather. The implement adduced by Dr. Evans as proving that palæolithic man was postglacial in England could not prove that he was later than *interglacial*

times ; and of an interglacial land-period in England there were the clearest possible proofs.

Mr. TOPLEY referred to the relative condition of land now and fifteen hundred years ago, which, he thought, must be of consequence in this discussion. From the remains of Roman works we might safely conclude that the physical condition of the country was practically unchanged since that date ; the fords of the Roman roads are often still in use, and no appreciable amount of valley-erosion has taken place in 1500 years. Under these circumstances he thought that we could not suppose such great changes as we know to have occurred could have taken place in only six or eight times that period.

The PRESIDENT suggested that Prof. Prestwich was not by any means the first person to lay down fixed terms of years for the duration and date of the Glacial period ; he found very definite terms laid down by other writers, and merely indicated reasons why these should be greatly reduced.

The AUTHOR did not attempt to fix actual definite terms of years, but only to show that we must not unhesitatingly accept such large measures of time, especially when based, as they were, upon an assumed and unproved necessity. He objected to remain in that state of ignorance with reference to time which some of the speakers seemed to find quite satisfactory. He referred to the observations of the Danish observers on the Greenland ice, as furnishing us with certain definite time-results, the application of which might be expected to help the question. It was a simple rule-of-three sum. If the Alpine data were supposed to accord with terms of 80,000 and 160,000 years, what are the numbers which should accord with the Greenland data ? It is impossible to contend that it would make no difference, which would be the conclusion implied by the observations of some of the speakers.

30. A REVISION of the ECHINOIDEA from the AUSTRALIAN TERTIARIES.
By Prof. P. MARTIN DUNOAN, F.R.S., F.G.S., &c. (Read
June 8, 1887.)

IN a communication to the Geological Society on the Echinodermata of the Australian Cainozoic deposits, which was printed in the Quarterly Journal of the Society, 1877, vol. xxxiii. p. 42, a list of the species of fossil Echinoidea which had been published up to that date was given, and eleven new species were described. Since the publication of that communication, there has been an important addition made to the Australian Tertiary fauna by Prof. R. Tate, F.G.S.*, who described *Salenia tertiaria* from the middle Tertiaries of Aldinga, south of Adelaide. This author also mentioned the occurrence of several genera which had not been considered to be members of the Australian Echinoid fauna, but he did not describe any of their species. Observations have been published upon the very interesting *Salenia* by A. Agassiz † and myself ‡. The only other communications on the subject of the Echinoidea have come from Prof. M'Coy §, who introduced three species of *Pericosmus* and a *Clypeaster* to the fauna, and, moreover, made some most valuable criticisms upon the work of previous observers. He has had excellent specimens, the examination of which has thrown much light upon some doubtful species ||.

In spite of the comparative paucity of species in this fauna, it has been very constantly before those palæontologists who have studied the other Echinoidean faunas of the East, and who have attempted to comprehend the affinities of the ancient faunas and that of the abyssal oceans. The extraordinary grouping of Cretaceous and Tertiary, as well as of recent, types in the Australian deposits has not been forgotten, although research amongst the fossil Echinoidea of other parts of the world has diminished the intensity and value of this peculiarity of the Australian Echinoid fauna.

As it is necessary that some of the species of Echinoidea should be revised, I have gone through the whole series, so as to leave as little opportunity for erroneous conclusions as possible. It will be found that some alterations are made which render the Cretaceous alliances of the fauna rather more decided than hitherto; but they will not assist in the linking of the deep-sea Echinoid fauna directly with the Cretaceous types.

* R. Tate, Quart. Journ. Geol. Soc. 1877, vol. xxxiii. p. 256.

† A. Agassiz, 'Report Challenger Echini,' 1881. p. 51.

‡ P. Martin Duncan, Ann. & Mag. Nat. Hist. ser. 5, vol. ii. p. 61 (1878).

§ F. M'Coy, Prodr. Pal. Vict. decades vi., vii. (1879, 1882).

|| The excellent Catalogue of Australian Fossils compiled by R. Etheridge, Esq., jun., and published by the Syndics of the University Press of Cambridge in 1878, records most of the Echinoidea, and of course all which were known to the author. For the list of Tertiary Echinoidea, see p. 138.

1. *CIDARIS* (*LEIOCIDARIS*) *AUSTRALIE*, Dunc. Quart. Journ. Geol. Soc. 1877, vol. xxxiii. p. 45, pl. iii.

There is nothing to add to the former description of this species.

2. There is another species of *Leiocidaris* in the fauna, but the specimen in the British Museum, Blanford Collection, from Bairnsdale ("E. 197"), is defective, there being only a portion of an inter-radium and ambulacrum. But the structures enable this form to be distinguished specifically from *Leiocidaris australie*, nob. The ambulacrum is rather undulating and narrow; the poriferous zone is very slightly sunken; the pores are large: the outer one of a pair is the larger and elliptical: the inner or adoral is round; they are united by a groove, and about seventeen pairs are in relation to a large inter-radial coronal plate. Interporiferous area with a row of small, imperfect secondaries, with slightly raised scrobicules and a small boss, no mamelon, placed close to the poriferous zone, and a series of smaller secondaries nearer the median line, in a vertical row extending along the middle of the area, but not reaching much actinally or far towards the apex. The primaries of the interradia are large; the scrobicules are distinct, nearly circular; and there is a row of small secondaries and a few granules between them and the horizontal sutures of the plates. The boss is broad at the base and conical, and the mamelon is contracted at the neck and is perforated. There is no crenulation. The margin of the scrobicular circle is sunken, and is surrounded by a row of small secondaries made up of an elongated raised scrobicule, longest transversely, and a small boss; there are a few smaller tubercles placed beyond the circle, and fitting in between the larger, so as to complete the circle, and a few exist beyond it. Two or three rows of still smaller tubercles extend along the plates beyond the circle towards the median line, and the median area of the interradium is narrow.

Numerous spines are in the collection, and the large and nearly smooth ones may be associated with this genus.

3. *GONIOCIDARIS*, sp.

There are several spines of a species of this genus present in the Cape Otway deposits.

4. *SALENIA TERTIARIA*, Tate, Quart. Journ. Geol. Soc. 1877, vol. xxxiii. p. 256.

This interesting species has been examined by me ('Annals and Magazine of Natural History,' 1878, ser. 5, vol. ii. p. 61), and reconsidered by A. Agassiz (Report on the 'Challenger' Echini, p. 51, 1881). It is a most interesting form, and large and well-grown.

The occasional entry of one of the radial plates into the formation of the anal ring is not enough to remove the species from the genus, for a similar entry is also inconstant in the recent *Salenia hastigera*, A. Agass. Moreover, Cotteau, Péron, and Gauthier have described Algerian Cretaceous *Salenia*, which have a radial plate entering the anal ring; and *Salenia Blanfordi*, Dunc. & Sladen, from the Eocene of

Sind, has a similar character. There is now no doubt that the succession of the species of *Salenia* has been from the Cretaceous age through the Eocene and Miocene to the present day, and that the definitions of the species indicate that the principal generic characters prevail in all. But it does not appear, from the consideration of the species of Mollusca, or of the other species of Echinoidea which are found in the same deposits as *Salenia tertiaria*, Tate, *S. Pellati*, Cott.*, and *S. Blanfordi*, Dunc. & Sladen †, that they were dwellers in deep water. Certainly the same kind of evidence, when applied in the instance of the Cretaceous forms of the genus, does not show that they lived under the same conditions as those species which have been dredged up from great depths. It would be more correct to say that there is no evidence to show that the ancient species had the same bathymetrical range as the recent forms. A. Agassiz, in his report on the 'Challenger' Echini, 1881, p. 209, explains that the range of the species as a group is from 60 to 1850 fathoms, and it may be reasonably assumed that the Tertiary species did not exist at the extreme depths, but that they and the Mollusca which were found associated with them were dwellers in a less depth than 500 fathoms.

5. *PSAMMECHINUS WOODSI*, Laube, 1869, Sitzungsber. Akad. Wiss. Wien, Bd. lix. p. 185; R. Etheridge, jun., Quart. Journ. Geol. Soc. 1875, vol. xxxi. p. 447.

The specimens of this *Psammechinus* in the collection of the Geological Society are fairly preserved, except in the apical system. They are small and tall, and certainly have triple compound plates formed upon the true *Echinus* principle; but although Mr. Etheridge, jun., has figured the apical system of a specimen in the Blanford collection now in the British Museum, which is similar to that of a common species, it will be observed that the Australian forms are somewhat unusual and aberrant.

6. *ORTHOLOPHUS LINEATUS*, Dunc.

Temnechinus lineatus, Dunc. Quart. Journ. Geol. Soc. vol. xxxiii. 1877, p. 46.

This form has given a vast amount of trouble in its classification, and it has been necessary to define a new genus for its reception. When the species was included by me in the genus *Temnechinus*, Forbes, the morphology of the plates of that genus and of *Temnopleurus* was not known; but subsequently a considerable number of Echinoidea, which had been placed under *Temnopleurus*, Agass., by d'Archiac and Haime, were studied by Mr. Percy Sladen and myself ‡. A few years ago § the morphology of the coronal plates of

* Rev. et Mag. de Zool. sér. 2, t. xii. p. 222 (1860). Eocene.

† Pal. Ind. ser. xiv. Foss. Ech. W. Sind, pt. 2, p. 28 (1882).

‡ Pal. Ind. ser. xiv. Foss. Ech. Sind, pt. 2, p. 36 (1882). Foss. Ech. Kach, p. 54 (1883).

§ Journ. Linn. Soc., Zool. 1882, xvi. p. 447; also A. Agassiz, Report on 'Blake' Echini, 1883, p. 37.

Temnopleurus and of *Temnechinus* was published, which enables the genera to be well separated. D'Archiac and Haime* passed very abruptly over the claims of *Temnechinus*, Forbes, and placed all the beautiful forms they discovered amongst the Sind Tertiaries in the genus *Temnopleurus*. They should, however, have been placed in *Temnechinus*. But associated with these forms were others which had a raised costulate ornamentation only, without furrowing of sutures or the presence of true and false pits. By the light of the morphological investigations, these species were removed from *Temnopleurus*, Agass., and *Temnechinus*, Forbes, and associated with the genera *Dictyopleurus*, *Arachniopleurus*, Dunc. & Sladen, &c., and it is in their neighbourhood that the species formerly named *Temnechinus lineatus*, nob., must come. In fact it is correct, from what is now known, to distinguish three alliances of genera, the Temnopleuroid, the Temnechinoid, and the Dictyopleuroid, and the species under consideration must come within the latter group.

Up to the present time no true *Temnopleurus* or true *Temnechinus* has been found in the Australian Tertiaries.

Laube† discovered and described an Echinoid which, unfortunately, had no apical system; but the basal and radial plates had left their impressions on the test surrounding the periproct. The ornamental characters associate this form with the Tertiary Dictyopleuroids of Sind and Kach, but there are more than specific distinctions between *Paradoxechinus novus*, Laube, and the costulated form called *Temnechinus lineatus*.

It is, however, evident that the apical system of the form which was termed *Temnechinus lineatus*, and which it is now proposed should enter a new genus, *Ortholophus*, is small, and not one half of the dimensions of that of *Paradoxechinus*, the measurement being made across the vacant spaces and as far as any evidence of former structure occurs.

The so-called *Temnechinus* had not the elongated periproct of the genus *Dictyopleurus* and of *Paradoxechinus*, and no radial plate entered the periproctal ring as in those genera. It is therefore necessary to define a genus for the species, which has a small apical system and a remarkable straight and crowded transverse costulation of the test.

Genus ORTHOLOPHUS, gen. nov.

The test is small, low, more or less pentagonal in marginal outline, subconical above the tumid ambitus. Apical system (wanting). Periproct small and circular. Ambulacra one half of the width of an inter-radium at the ambitus, straight, with slightly sunken poriferous zones; pairs in ill-defined triplets nearly in straight series, appearing on the edges of transverse costæ. Compound plates with a central demiplate, the others primaries. A vertical row of small imperforate non-crenulate primary tubercles is close to the poriferous zone, and

* Anim. Foss. de l'Inde, p. 202.

† Laube, Sitzungsab. Akad. Wiss. Wien, Bd. lix. p. 186, fig. 2 (1869).

the median area is crowded with nearly straight ridge-like costæ, passing from the bases of the primaries almost transversely, and carrying small secondaries. Interradia with two vertical rows of primaries of the same size and structure as those of the ambulacra, their scrobicules raised and united with those above and below by vertical straight costæ, and with those of the opposite row by numerous crowded, transverse, straight costæ, with small secondaries on them. Peristome small, almost without cuts.

ORTHOLOPHUS LINEATUS, Dunc. (See the description of the species under the generic head of *Temnechinus*, Quart. Journ. Geol. Soc. vol. xxxiii. p. 46.)

The dimensions of the specimen are: height 8 millim., diameter 14 millim., width of apical system 4 millim.

The alliance of this form is closest to the recent *Trigonocidaris*, A. Ag., and it is the representative of the *Dictyopleuri* of the Tertiaries of Sind, Kach, and Egypt.

7. *PARADOXECHINUS NOVUS*, Laube*.

The impressions left by the basal and radial plates upon the test close to the anal margin indicate that the last-named plates were placed between the others, and that they all entered the anal ring; the anal opening was large, and the apical system appears to be depressed according to Laube's evidently correct drawing of the species. The height of the test is 6.5 millim., the diameter 13 millim., and the diameter of the anal opening 7 millim., whilst that of the peristome is only 4 millim. The pairs of pores are on the plates of the test, and not upon costæ, and the oblique direction of the zigzag of bunches of costæ is very striking; the primary tubercles are neither crenulate nor perforate. The branchial cuts are very small. This is a well-defined genus and species, and if the statement about the apical system just made turns out to be absolutely correct, then the alliance is with the Eocene *Dictyopleuri* of Sind and of Egypt. Cotteau has defined a genus, *Coptechinus* ("Éch. nouv. ou peu connus," Extr. du Bull. de la Soc. Zool. de France, 1884, fasc. 2, p. 27), and the species is from the Miocene of France; but the form so well described is clearly a species of *Paradoxechinus*, that genus having escaped the observation of the distinguished French Echinodermatist. It is very interesting to be able to trace this westerly development of an Australian genus. *Paradoxechinus novus* was found in the deposits of the Murray Cliffs, South Australia.

8. *CLYPEASTER FOLIUM*, Agass. Cat. rais. p. 73; Desor, Synopsis, p. 243.

A variety, var. *elongata*.

So long ago as 1864 I asserted the presence of *Clypeaster folium*, Agassiz, in the Murray Cliffs and at Mount Gambier, South Australia (Ann. & Mag. Nat. Hist. 1864, vol. xiv. p. 166). But Mr. R. Etheridge, jun., in his communication to this Society in 1875,

* *Tom. cit.* p. 186, fig. 2.

remarked that he had compared the specimens identified with *Clypeaster folium* with *Monostychia australis*, Laube, and that he found them one and the same. In 1877 I accepted Mr. R. Etheridge's correction with a necessary explanation (Quart. Journ. Geol. Soc. vol. xxxiii. p. 48). But there is at least one excellent specimen of a *Clypeaster* in the National Collection (Blanford Coll., Geelong, Victoria E. 1,108, marked X), and it has the specific characters of *Clypeaster folium*, Agass. The specimen was compared with a small *Clypeaster folium* from the Miocene of Corsica, in the British Museum, and with a full-grown type from Malta, also in the National Collection; careful measurements were taken, and with the following results:—

The relational measurements of a small *Clypeaster folium* from Corsica (length 47 millim.; 47=100): length 100, width 95·7, height 17. The measurements of the large type from Malta, the length being 93 millim: length 100, width 86, height 18·4. The measurements of the middle-sized specimen from Geelong (length 66 millim): length 100, width 84·8, height 17·4. The comparison of these measurements with those taken by M'Coy of *Clypeaster gippslandicus* shows that the height of that form is much greater than that of *Clypeaster folium*, being 27 in relation to 100. In the form which I consider to be a mere variety of *Clypeaster folium*, Agass., the petaliferous part of the ambulacra is very slightly raised and the flatness of the test is very marked. But there are the same characters, regarding shape and relative size, in the petals of the three specimens measured. In a typical *Clypeaster folium* the anterior petal is the longest, and its breadth is the same as that of one of the antero-lateral petals, which is, however, shorter; the postero-lateral petals are the shortest and widest. The measurements in the Australian type are:—anterior ambulacral petal 18 millim. long and 12 millim wide; antero-lateral petals 16 millim. long and 12 millim. wide; postero-lateral petals 11 millim. long and 13·5 millim. wide. The anterior petal is widely open, and the postero-lateral are less so, but are large distally, and the antero-lateral petals are nipped in near the end where the pores of the opposite zones approach to a considerable extent. This narrowing of the distal ends is very striking and persists in all the specimens.

The shape of the test of the Geelong form is rather longer than is usual in European specimens, and there is perhaps a little more rounding of the thin posterior margin of the test. The shape differs materially from that of *Clypeaster gippslandicus*, M'Coy, and the ornamentation of the costæ of the poriferous zones and of the test between the tubercles is also different in the two forms.

If the Geelong *Clypeaster* had been found in Malta, it would have been put down at once as a variety of *Clypeaster folium*, and I therefore give it that name.

9. CLYPEASTER GIPPSLANDICUS, M'Coy, 1879*.

Echinanthus testudinarius, Gray.

Prof. M'Coy considers that *Echinanthus testudinarius*, Gray, which

* Prodr. Pal. Vict. dec. vi. 1879, p. 33.

was stated to be a fossil in the Mitchell-river Tertiaries by Mr. Tenison-Woods and myself, is a species of *Clypeaster*. The classificatory position of the form I examined was a subject of doubt, as will be gleaned from the following extract:—"Except in some slight points in which there is great individual variation in the recent forms, the fossil agrees with those which Gray called *E. testudinarius* and *E. australis*, the latter of which has been absorbed by the former. The species is interesting from its close resemblance to a *Clypeaster*; but it has no pores close to the sutures of the plates within the ambulacra on the actinal surface" *.

M'Coy has shown that the internal structure of the test is that of a *Clypeaster*, according to A. Agassiz, and he has investigated the subject of the ambulacral pores and finds that they are variable; but probably that is produced by fossilization.

Prof. M'Coy considers that the morphological distinction between *Clypeaster* and *Echinanthus*, according to A. Agassiz, is barely sufficient to separate the genera; and it must be remembered that, with the exception of the greater concavity of the actinal surface in *Echinanthus*, the other structural differences are internal. The specimen examined by Mr. Tenison Woods was not studied by me, and Prof. M'Coy has not had the advantage of examining the very large form which was noticed in my former communication, and which is in the collection of this Society. It is exceedingly Echinanthine in its general appearance, but the test is flat actinally for some distance towards the deeply sunken peristome. The relative measurements of *Clypeaster gippslandicus*, M'Coy, are:—length 90 millim.=100, width 88, height 27. Those of the large form now under consideration are:—length 105 millim.=100, width 85·7, height 31. The suspicion that the two forms are not specifically identical is somewhat aroused by the relative increase in length of the larger form, and is intensified by the petals of the larger form being much broader than those of the other; moreover, the postero-lateral petals of the Gippsland species are longer than those of the larger form. If the drawing of the terminations of the petals given by Prof. M'Coy is correct, there is almost, if not quite, a specific difference between the forms, for the antero-lateral petals are tending to close, and are rather narrow externally, in the form which came under my observation. In fact there is a facies about the petaloid part of the test which recalls *Clypeaster folium*. Subject to this expression of doubt, I agree with M'Coy in considering the form to belong to his *Clypeaster gippslandicus*.

In my former communication (p. 66) I expressed my belief in the identity of *Monostychia*, Laube, and *Arachnoides*, Klein, mainly owing to the furrowing of the ambulacra; and the drawing and description given by Laube of the internal supporting structures of the test (Laube, "Fossil Echinoidea from the Murray Cliffs," Sitzungsber. Akad. Wiss. Wien, vol. lix. Bd. i. 1869, p. 188, fig. 3c). At that time the reasons for separating the genus *Monostychia* from *Arachnoides* were the not invariable supramarginal position of the

* Quart. Journ. Geol. Soc. vol. xxxiii. (1877) p. 47.

periproct in *Arachnoides*, and the variable notching of the test-margin in *Monostychia*. It was evident that the position of the periproct was variable in *Arachnoides*, and that it was found quite marginal, as well as inframarginal, in *Monostychia*. M'Coy figured the internal supporting structures of *Monostychia* in his 'Prodromus,' and it agrees generally with the drawing by Laube, and there are no structures to be seen near the margin of the test. He considers *Monostychia* a good genus and retains it. Having had the opportunity of examining very much better specimens than those which I studied formerly, and having seen a fortunate fracture of a specimen of *Monostychia australis*, Laube, I still find myself in the difficulty of not being able to agree with my fellow-workers. My reading of the nature of the internal part of the test does not agree at all with that of my predecessors. But it is necessary that I should state that, had I seen the specimen I now allude to, I should not have placed the specimens in relation with *Arachnoides*. The new specimens have enabled me to make out the distribution of the pores beyond the petaloid parts of the ambulacra, and to describe the nature of the plating of the actinal surface, and the nature of the plates which enter the peristomial margin. It now appears to me that the alliance is with *Clypeaster*, a notion which, so far as I am concerned, dates back to 1864.

In the figures published both by Laube and by Prof. M'Coy no internal supporting structures are seen near the edge of the test. This is unlike the structures of all *Clypeasters*; but on examining the worn edges of several of the tests in the National Collection, the presence of upright and small needle-shaped pillars became evident, and this *Clypeastroid* character became still more pronounced on studying one of the specimens which had been fractured across. In the best-preserved specimen the appearance of the structures which occur between the upper and the actinal parts of the test within is almost exactly identical with that presented by *Clypeaster subdepressus*, Gray, sp. The needle-shaped pillars with different diameters are the same in structure as those represented in A. Agassiz's 'Revision of the Echini,' 1874, pl. xiii. fig. 15. The flatness of the test is quite equalled in small specimens of *Clypeaster folium* from Corsica; and there is no appreciable difference in this respect between a rather elongated specimen of the *Clypeaster* and the young specimens of *Monostychia* in the collection of the Society. In both genera the ambulacra are grooved radially on the actinal surface, but in the Australian forms the groove is continued definitely over the margin, and reaches up close to the actinal system; moreover, the edge of the test is notched at the ambulacral margins at the place where the grooves are seen. The groove is not a simple depression of the test along the median line of the ambulacrum, for close to the peristome there is a slight median ridge, which is also seen on the little projection which each groove makes into the peristome and beyond the rest of its plates. In one specimen, pores are seen on either side of the ridge, and connected with it by indistinct grooves. Beyond the pores, and just within the interradial

sutural edge of the ambulacral plate, is a row of close and small granules. The peristomial termination of each groove is in two terminal ambulacral plates, which are narrow, and each pair of ambulacral plates is separated from its neighbours, on either side, by a single peristomial interradiial plate. The second ambulacral pair of plates are larger than the peristomial, and are sutured along the median line of the interradia with the neighbouring pair of ambulacral plates, there being no interradiial plate intervening. This discontinuity is as in *Clypeaster*. The second plates are marked with obliquely arranged granules, and are pierced by numerous small pores, so that two triangular areas are thus marked, the base of each being in contact along the median line of the ambulacrum, one side being along the aboral suture of the plate, and the third side being along a line drawn from the peristomial end of the median suture of the plate across to the aboral and interradiial angle of the plate. A corresponding ornamentation occurs on the next and some other pairs of plates, and is comparable with the peculiar appearance shown by *A. Agassiz* in his drawing of the actinal surface of *Clypeaster Ravenellii*, *A. Ag.* ("Echini of the Blake Exped." Mem. Mus. Comp. Zool. Harvard, vol. x. No. 1, 1883, pls. xv. *b*, xv. *c*).

There are very few pores to be seen in the groove abactinally, and the ambulacral plates beyond the petaliferous part are crowded with minute pores close to the groove, but not far from it.

The position of the periproct is inframarginal and rarely at the margin, and there is slight swelling of the test (not so much as in Laube's figure) actinally and abactinally along the path of the intestine in relation to the posterior interradium.

The jaws are not seen in any of the specimens, but it appears that the low perignathic ridge-process is placed, as in *Clypeaster*, upon the edges of the peristomial ambulacral plates.

The coronal plates, actinally, are well marked near the margin of the test, and the petaloid parts of the ambulacra resemble those of *Clypeaster*; but the interradia are greatly diminished in breadth near the apical system.

The apical system is small and the madreporite is central and button-shaped, the four genital pores being immediately external to it. There is no posterior genital opening.

Two young specimens show that the notching of the margin and the distinctness of the abactinal grooves are matters of growth; and it is quite pardonable for any naturalist who is aware of the great diversity of shape assumed by Clypeastroids in their youth to place the young forms out of the genus or subgenus *Monostychia*. It is evident that while there are some structural resemblances to *Arachnoides* in the actinal part of the test, the principal structural characters of physiological importance are all Clypeastroid.

There are not sufficient data to separate the species from the very flat Clypeasters, and I propose to retain *Monostychia* as a subgenus of *Clypeaster*.

10. CLYPEASTER (MONOSTYCHIA) AUSTRALIS, Laube, *op. cit.* p. 190.

Arachnoides australis, Dunc. *op. cit.* p. 48.

Arachnoides australis, var. *elongatus*, Dunc. *op. cit.* p. 48.

Clypeaster (Monostychia) Loveni, Dunc.

11. CLYPEASTER (MONOSTYCHIA) LOVENI, Dunc. *op. cit.* p. 47.

It is proposed to omit *Echinarachnius parma* from the list, and it is necessary to observe that fragments of a species of *Fibularia* and of an allied genus are in the collection at the British Museum.

12. ECHINOBRISUS AUSTRALÆ, Dunc.*

There is nothing to add to the description of this species, which is closely allied to the recent species of the subgenus *Nucleolites*. The anal groove is long and pronounced in the Australian species, and, moreover, some of the pairs of pores are conjugate and others non-conjugate.

13. CATOPYGUS ELEGANS, Laube †.

It will be interesting to know whether this species differs from the Cretaceous species in the same manner as the recent *Catopygus recens* does. This last-mentioned species has but a single row of pores, reaching from the petaloid part of the ambulacra to the peristome, and not a row of pairs of pores on either side of the ambulacra. The position of the periproct is not that of the Cretaceous forms. See A. Agassiz, 'Report on Challenger Echini,' p. 123. I believe that the Tertiary and recent *Catopygi* should be placed in a subgenus.

14. PYGORHYNCHUS VASSALI, Wright ‡.

15. ECHINOLAMPAS OVULUM, Laube §.

This species was very shortly described by Laube and not figured. The measurements of the test were not given. The pentagonal, ovoid, and somewhat rostrated high form and the very broad ambulacra distinguish the species from all others. A specimen in the British Museum, Blanford collection, is 57 millim. long, 49 millim. broad, and 33 millim. high. There is but slight difference between the lengths of the poriferous zones and the antero-lateral ambulacrum, 20 millim. long and 8 millim. broad, the posterior one 23 millim. long and 95 millim. broad.

16. HOLASTER AUSTRALÆ, Dunc. *op. cit.* p. 51, pl. iii. figs. 12 and 13.

There is no alteration required in the description of this species

* Dunc. Quart. Journ. Geol. Soc. vol. xxxiii. p. 50.

† Laube, *op. cit.* p. 190, fig. 7.

‡ Dunc. *op. cit.* p. 51.

§ Laube, *op. cit.* p. 191.

except in the matter of ornamentation. The ornamentation is of small tubercles, crenulated and perforated and surrounded by a plain scrobicular area flush with the test; the scrobicules are separated by a very delicate granulation. This ornamentation is largest actinally and resembles that of *H. suborbicularis*, Agass. The shape of the test resembles that of *H. Perizi*, Sismonda, and the very shallow anterior groove is smaller than that of *H. subglobosus*. The figure of the apical disk is in part incorrect, and the woodcut

Apical System of Holaster australiæ, Duncan.

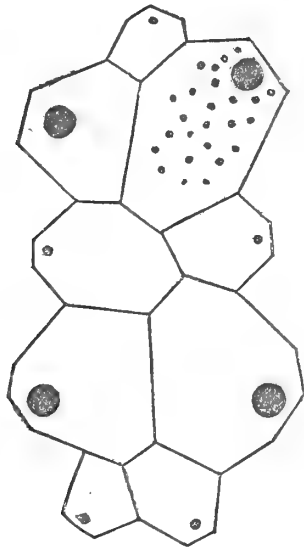

now given should supersede it. This is a true *Holaster*, and so is the species which I wrongly attributed to an abnormal form of *Rhynchopygus*—*R. dysasteroides*, Dunc.

17. *HOLASTER DIFFICILIS*, Dunc. *op. cit.* p. 49, pl. iii. figs. 9 and 10.

Rhynchopygus dysasteroides, Dunc. *op. cit.* p. 49, pl. iii. figs. 9 and 10.

The specimen has been crushed from above downwards, but there is no doubt in my mind now that the apical system is *Holasteroid* and not *Dysasteroid*. The ornamentation is *Holasteroid*. Otherwise the descriptive part of the notice of this species given in the communication now under revision is correct, but all the references to the affinities on p. 50 are erroneous. Both of the *Holasters* came from the Upper Coralline beds, Castle Cove, Cape Otway.

18. *MICRASTER BREVISTELLA*, Laube, *op. cit.* p. 192, fig. 7, non 8; and R. Etheridge, jun., *Quart. Journ. Geol. Soc.* vol. xxxi. p. 448, figs. xi. & xii.

This species has been fully elaborated by the above-named

authors, and it is especially mentioned here in order to bring it into relation with a *Micraster* from the Indian Nummulitic deposits.

The height and general tumidity of the test and the short ambulacra separate the Australian form from all the Cretaceous species of the well-known genus; but in these details there is an evident alliance with *Micraster tumidus*, Dunc. & Sladen, from the Khirthar or true Nummulitic limestone of Western Sind (Pal. Ind. ser. xiv. pl. iii. p. 189, 1884). This species, from older Tertiaries than those of Australia, has slightly longer and wider ambulacra than the other, and in both the evidences of a subanal fasciole are not satisfactory. The posterior groove leading from the margin to the periproct is more decided in the Australian form, and the whole of the posterior surface is wider in the Australian form than in the Indian. The British Museum specimen is 50 millim. high, 62 millim. long, 51 millim. broad, and it has traces of a subanal fasciole (not a lateral one, as stated in the former paper).

19. *MARETIA ANOMALA*, Dunc. *op. cit.* p. 52, pl. iv. figs. 1-4. E 296

The abnormality in this species is the presence of a more or less discontinuous fasciole just above the ambitus. Since the description of the species, A. Agassiz has found a corresponding fasciole in a recent species.

20. *MEGALASTER COMPRESSUS*, Dunc. *op. cit.* p. 62.

The species is retained provisionally, for the ornamentation has almost all disappeared and the possibility of its turning out to be a *Pericosmus* is considerable, as will be understood after reading M'Coy's observations on that genus. But it must be admitted that the specimen in the British Museum does not show the least trace of fascioles, and that there are clear specific distinctions between it and any species of *Pericosmus*, leaving out the consideration of the fascioles. The length of the specimen (E 296, B.M.) is 5 inches, the width 4.75 inches, height 2.1 inches. The apical system is more or less deficient, but the radial plates are small, obscurely quadrangular and longer than wide; the tentacular pore is very large, the poriferous plates of the ambulacra, near the radial plates, are small and perforated by pairs of minute foramina; and in the posterior lateral ambulacra, at about the sixth plate, the plates dip down into the ambulacral groove. At a little distance from the small plates the others become large, low and broad, and the inner pore is large and slightly elongate, although, on the whole, circular in outline, and the outer pore is very long and most open externally. There is no groove between the pores of a pair, and the pairs are separated by very distinct and ornamented costæ. The anterior ambulacral pores are all small and circular and become very distant halfway down the very deep and broad groove. The postero-lateral petals are slightly wavy, long, narrow, and deep; they are in a narrow depression of the test, so that the poriferous zone does not come up to the level of the test, but is on the flank of the depression.

The length of these petals is 31 millim., width in the middle 6 millim., extreme depth of the depression 6 millim. There are forty pairs of pores, and the interporiferous area is very equal in width throughout, except near the radial plate, and is slightly narrower than the poriferous zone. The antero-lateral petals are longer than the others (33 millim.), their width is 6.5 millim., and they are shallower, 4 millim. The highest part of the test is in interradia 1 and 4, and near the apex, which is excentric in front. The slope is sudden from the apex in front, and gradual behind for a short distance, and then there is some tumidity of the posterior interradium. There is no keel there, and the interradium is rather narrow on account of the angle made by the ambulacra being 60 degrees.

The anterior petals diverge at an angle of 120 degrees. The posterior truncation is low and broad, and the periproct is close to the upper edge of it and is elliptical transversely. Width of the truncation 60 millim., height 35 millim.; height of the periproct 11.5 millim., width 21 millim. There is a slight re-entering curve quite at the posterior actinal edge. The actinal surface is very flat, and the large, wide, very anteriorly placed mouth has a downward projecting labium 22 millim. broad.

The ornamentation is largest on the flanks of the anterior groove, and consists of small perforate mamelons on conical bosses, crenulated and placed on a level, large, plain scrobicule, with miliary granules on the edges. Elsewhere the tubercles are smaller, and there is a small granulation between their more distant scrobicules.

Locality, Murray Cliffs. This specimen is slightly larger than that which was figured in the former communication and which, unfortunately, has been mislaid.

21. *PERICOSMUS GIGAS*, M'Coy, Prodr. Pal. Vict. dec. vii. 1882, pls. 64 & 65, p. 15.

This huge species attains the length of 7 inches 6 lines and is nearly as broad, the height, however, being only about one half of the length. The specimens described by M'Coy are wonderful, and the minute ornamentation, the peripetalous fasciole clinging to the petals and reaching along the anterior one to behind the deep notch, and the lateral fasciole are very characteristic of the genus. The lateral fasciole is, however, more or less discontinuous in the species.

22. *PERICOSMUS NELSONI*, M'Coy, *op. cit.* pls. 66 & 67.

This is another well-marked species.

23. *PERICOSMUS COMPRESSUS*, M'Coy, *op. cit.* pls. 67 & 68, p. 21.

This is a large and compressed species, and has a very close resemblance in shape to *Megalaster compressus*, nob. (Quart. Journ. Geol. Soc. 1877, vol. xxxiii. p. 62). Supposing *Megalaster compressus* to be a well-scrubbed fossil, from off which all traces of fascioles have been worn, may it not be a *Pericosmus*, and is it not a worn *Pericosmus*

compressus? M'Coy considers that these questions may be answered possibly in the affirmative; but, after a careful examination of the specimen, I could find no fascioles.

24. LOVENIA FORBESI, Woods & Duncan.

A passage in M'Coy's 'Prodromus' places palæontologists in a considerable difficulty regarding the correct authorship of this species. Is it to have the names placed after it as above, or ought the name of Prof. M'Coy to stand in their place? It does not matter much to whom the naming of the species should be accredited, now that the whole of the morphology of the test has been published. But, divesting this subject of all personal feeling (and I am glad to say none has ever been felt by Prof. M'Coy and myself), the question turns upon the old settlement of former disputes. Are MS. names of species to take priority? It has been decided over and over again that MS. names do not take priority of those which have been accompanied by comprehensible and published specific definitions. This interesting form has quite a literature of its own, as may be noticed by reading Mr. R. Etheridge, jun.'s, elaborate communication to the Society (Quart. Journ. Geol. Soc. vol. xxxi. p. 445), and by referring to the essay of which this is a revision. Since those pages were written, Prof. M'Coy has given a still more elaborate history of the species.

The first discoverer of the Echinoid was Sturt, the traveller, who named a common Urchin, in 1832, *Spatangus Hoffmanni*, Goldf. The identification was erroneous.

In 1852 Forbes gave some lectures at the Museum of Practical Geology, London, on Gold, &c., and they were published. The Echinoid was mentioned by him as a *Spatangus*, without a specific name, and an imperfect figure was given of it. In 1859 M'Coy named the specimens in the Melbourne Museum, and wrote *Spatangus Forbesi* on the tablets. He did not write or publish any description of the species. In 1862 Mr. Tenison Woods published a drawing of the Echinoid in his 'Geological Observations in South Australia,' and called it *Spatangus Forbesi*. In 1864 I could not find any description of the species, and showed that it was a *Hemipatagus*, from the nature of the specimens sent to me by Mr. T. Woods. I described this species, naming it *Hemipatagus Forbesi*, Woods & Duncan, and had the type drawn ('Annals and Magazine of Natural History,' ser. 3, vol. xiv. p. 165, pl. 6). In 1869, Laube named the species *H. Forbesi*, and placed Mr. T. Woods's name after it. He had not seen my communication, I presume. In 1875 Mr. R. Etheridge, jun., advanced the knowledge of the morphology of the test by discovering a subanal fasciole (Quart. Journ. Geol. Soc. vol. xxxi. p. 445) in a form which he considered specifically distinct from *H. Forbesi*, Woods & Duncan, but which must now be considered to be a variety. He recognized the propriety of associating the names of Mr. T. Woods (who gave me such assistance in describing the species that I was bound to connect him with my work) and myself with *Hemipatagus Forbesi*.

In 1877 I found the internal fasciole of the test, and completed the description of the morphology. But as the species could no longer remain as a *Hemipatagus*, I placed it within the genus *Lovenia*, and the species became *Lovenia Forbesi*, Woods and Duncan (Quart. Journ. Geol. Soc. 1877, vol. xxxiii. p. 58).

In the Prodr. Pal. Victoria, dec. vi. p. 39 (1879), Prof. M'Coy considers that "I, also, will probably prefer to leave it now under the old authority," meaning that the species should stand as *Lovenia Forbesi*, M'Coy, sp. It is, of course, not of much importance whose name is to stand after the species, provided the palæontologist who is studying the Australian fauna can be directed to the first and most correct specific definition. That given by M'Coy, in 1879, leaves nothing to be desired, nor is that given previously by me otherwise than correct.

If MS. names on a tablet in a museum are to be of greater value than careful descriptions and delineations, then the best plan will be for the recognizers of new forms simply to name them and to leave the description to the chapter of accidents. As a personal matter, I would leave the name to be placed after the specific name as Professor M'Coy wishes; but it is not in the interest of science to do so, and the personal names placed after a species must be those of the first writers who first defined the species so that it could be recognized by subsequent observers.

M. Pomel ('Thèses par A. Pomel, Class. méthod. Ech. viv. et foss.' Alger, 1883, p. 28) has diagnosed a genus *Sarsella*, which differs from *Lovenia*, Desor, in not having the ampullæ visible on the inner surface of the test beneath the sunken scrobicules of the primary tubercles. *Lovenia Forbesi* is included by M. Pomel in his genus. Now the occurrence of these projections, rounded in shape and with a depression in them, are in relation with the bases of the smaller actinal tubercles as well as with the more important large primaries (A. Agassiz, 'Revision,' pl. xxxviii. figs. 28 & 28'); they arise from the thin condition of the test, and the hollows are the involuted bases of the tubercles, whilst the swellings are the inward projection of the scrobicules. The thicker the test the less visible are these characters. They are visible in the recent forms; but unless a fossil *Lovenia* be so preserved that the matrix within clears out readily, there is no opportunity of noticing whether this particular structure prevails in the stout tests. In the only instance I have had of a form with an unusually delicate test, and which was fractured, I saw slight relics of the roundings within. As all other characters of physiological value are the same in the recent and fossil *Loveniæ*, and as the character relied upon by M. Pomel is not of primary physiological value, I do not consider that he has shown the necessity for the introduction of a new genus. Again, I am by no means satisfied that *Sarsella mauritanica*, Pomel, described and figured in Cotteau's 'Ech. Foss. de l'Algérie, Étage Eocene,' 1885, p. 36, pl. i. figs. 4-8, is a *Lovenia* without ampullæ. There is most certainly no internal fasciole present, nor is a sub-anal one visible. Cotteau (p. 38) states that M. Pomel has not

definitely stated that he has found an internal fasciole in his specimens, and has given no details of any. Cotteau does not know whether to call M. Pomel's typical species a *Sarsella* or a *Maretia*. It is quite apparent, on comparing the figures of *Maretia planulata* given by A. Agassiz ('Revision,' pl. xix *b*. fig. 7), and *Maretia anomala*, nobis (Quart. Journ. Geol. Soc. vol. xxxiii. pl. iv. fig. 1), that M. Cotteau was justified in his doubt, and that if a subanal fasciole exists, the species is really a *Maretia*; if not, the species belongs to *Hemipatagus* (Desor, 'Synopsis,' tab. 44).

Before perfect specimens of *Lovenia Forbesi* had been obtained Mr. Tenison Woods had considered the form under consideration to be a *Hemipatagus*, and this genus of Desor's is characterized by the test being small and furnished with large interradial primary tubercles, resembling those of *Spatangus*, but absent in the posterior interradium, by the plastron being in general smooth, as if worn, and by having projecting and elongate petals, four genital pores and no fascioles. Yet M. Pomel places *Maretia*, Gray, as synonymous with *Hemipatagus* (*op. cit.* p. 29). It is perfectly evident that *Maretia* has a subanal fasciole and often a discontinuous narrow lateral fasciole; this last has been noticed by A. Agassiz and myself. *Maretia* according to Cotteau is therefore not *Hemipatagus* according to M. Pomel.

25. EUSPATANGUS ROTUNDUS, Dunc.

Eupatagus rotundus, Dunc. *op. cit.* p. 53, pl. iii. figs. 14-17.

The relative dimensions of this species and the want of any contraction on either side posteriorly separate it from the other forms of the genus from Australia and elsewhere.

26. EUSPATANGUS LAUBEI, Dunc.

Eupatagus Laubei, Dunc. *op. cit.* p. 55. E 42441

The classificatory position of this form is not without doubt, for it has the primary tubercles "enviored by the peripetalous fasciole" small and even present in the posterior interradium as in *Peripneustes*. In all other respects the species is a true Euspatangoid. A similar difficulty was met with by Mr. Percy Sladen and myself in studying *Euspatangus avellana*, d'Archiac & Haime, and we noticed the affinity of that species to *Macropneustes* (Pal. Ind. ser. xiv. Foss. Echin. W. Sind, pt. iii. p. 237). The presence of a subanal fasciole was not mentioned by me in my former communication, and now I can add that it is well developed. E 42441 or E 42443

27. EUSPATANGUS MURRAYENSIS, Laube.

Eupatagus murrayensis, Laube, *op. cit.* p. 196, fig. 4.

This species is very oviform in shape and high behind, and differs from the other species very definitely.

28. EUSPATANGUS WRIGHTI, Laube.

Eupatagus Wrighti, Laube, *op. cit.* p. 195, fig. 5.

There is some affinity between *Euspatangus rostratus*, d'Archiac,

and this species, and on the other hand the recent *Euspatangus Valenciennesi*, Agass., is allied to *Euspatangus murrayensis*.

29. SCHIZASTER VENTRICOSUS, Gray, 1851, Ann. & Mag. Nat. Hist. vol. vii. p. 133.

A fragment of this recent form is in the Blanford collection in the British Museum.

List of the Species of Australian Tertiary Echinoidea.

1. *Cidaris (Leiocidaris) australice*, Dunc. Cape Otway.
2. — (—), sp., Dunc. Bairnsdale.
3. *Goniocidaris*, sp. Spines. Cape Otway.
4. *Salenia tertiaria*, Tate. Aldinga, South of Adelaide.
5. *Psammechinus Woodsi*, Laube. Murray Cliffs.
6. *Ortholophus lineatus*, Dunc., syn. *Temnechinus lineatus*. Mordialloc.
7. *Paradoxechinus novus*, Laube. Murray Cliffs.
8. *Clypeaster folium*, Agass., var. *elongata*, Dunc. Geelong.
9. — *gippslandicus*, M'Coy. Gippsland.
10. — (*Monostychia*) *australis*, Laube, sp. Murray Cliffs.
11. — (—) *Loveni*, Dunc. Murray Cliffs.
12. *Echinobrissus australice*, Dunc. Cape Otway.
13. *Catopygus elegans*, Laube. Murray Cliffs.
14. *Pygorhynchus Vassali*, Wright. East of Glenelg.
15. *Echinolampas ovulum*, Laube. Murray Cliffs.
16. *Holaster australice*, Dunc. Castle Cove, Cape Otway.
17. — *difficilis*, Dunc., syn. *Rhynchopygus dysasteroides*, Dunc. Cape Otway.
18. *Micraster brevistella*, Laube. Murray Cliffs.
19. *Maretia anomala*, Dunc. South of Sherbrook River.
20. *Megalaster compressus*, Dunc. Murray Cliffs.
21. *Pericosmus gigas*, M'Coy.
22. — *Nelsoni*, M'Coy.
23. — *compressus*, M'Coy.
24. *Lovenia Forbesi*, Woods & Dunc. Mordialloc.
25. *Euspatangus rotundus*, Dunc. Murray Cliffs.
26. — *Laubei*, Dunc. North of Sherbrook River.
27. — *murrayensis*, Laube. Murray Cliffs.
28. — *Wrighti*, Laube. Murray Cliffs.
29. *Schizaster ventricosus*, Gray. Adelaide district?

Varieties :—

Clypeaster (Monostychia) australis, Laube, var. *elongata*, Dunc.
Lovenia Forbesi, Woods & Duncan, var. *Woodsi*, R. Etheridge, jun.

On studying this list of Australian Tertiary species of Echinoidea, it will be observed that there is but one species (*Schizaster ventricosus*) which belongs to the recent fauna. It has not an Australian habitat, but is found widely in the Pacific area and as far north as Japan. Of the nineteen genera found represented in the Tertiaries, only seven, possibly, have species in the recent Australian fauna,

which numbers (counting three deep-sea forms) at least thirty-one genera*. Even such common Australian genera as *Salmacis*, *Amblypneustes*, *Holopneustes*, *Breyntia*, and *Echinocardium* are not represented in the list of fossil species. In this slight relation to the recent fauna the Australian Tertiary Echinoidea resemble the fauna of the Tertiaries of Sind, Kach, Kattywar, and the Mekran coast; in both instances the percentage-method of classifying Tertiary deposits will fail, and the explanation must refer to the great changes which occurred along all the coast-lines of that part of the world at the close of the Pliocene age.

As a whole, the grouping of the genera of the Australian Tertiary Echinoidea is a mixture, and it is characterized by the presence of genera which commenced in the Mesozoic ages, of a majority of genera which began in the Tertiary ages and have lasted on, and of a few characteristic Tertiary genera. There are three genera special to the fauna.

But when the genera which began in the Mesozoic age are considered, it will be found that four of them are represented by living species, for instance *Cidaris*, *Salenia*, *Echinobrissus*, and *Catopygus*. *Micraster* lasted into the Nummulitic of Sind, and the Australian species is the latest; and the Holasters are recognized, only in Australia, as Tertiary forms and not early Tertiary.

The essentially Tertiary species are those of the genera *Pygorhynchus* and *Pericosmus*. The genera which arose during the Tertiary ages and are still represented by species are *Echinolampas*, *Maretia*, *Lovenia*, *Euspatangus*, *Schizaster*, *Clypeaster*, *Psammechinus*, and *Goniocidaris*. The special genera are *Ortholophus*, *Paradoxechinus*, and *Megalaster*, and the first two have very Sindian (Eocene) alliances.

The greatest interest of the fauna is, of course, centered in the Holasters, and every student of the recent fauna will recognize their importance in reference to the abyssal Echinoidea with apetalous and flush paired ambulacra, and which present such a curious mixture of antique and very modern structures. But instead of allying the abyssal Ananchytyoid-looking forms, classified under the genera *Homolampas*, A. Ag., *Genicopatagus*, A. Ag., *Cystechinus*, A. Ag., and *Urechinus*, A. Ag., with the Holasters and Ananchytes of the Chalk, it will be necessary to consider them in reference to the Holasters of the later Tertiaries of Australia. Just as it is now necessary to consider the recent *Salenia* as the modified descendants of the Tertiary species, so it is obligatory to believe that the very degraded and yet in some points very anciently structured abyssal species of the genera mentioned above are the modified and degenerate successors of Tertiary predecessors.

There are no species which are common to this Australian fauna and that of the Indian Tertiaries, and the alliance with the European faunas is slight indeed. The large species of *Pericosmus* recall the forms from the Javan Tertiary deposits, but the species of the two localities are not the same.

* Ramsay, Catal. Echin. Austr. Mus. pt. i. (1885).

No satisfactory information regarding the Tertiary Echinoidea of New Zealand has been obtained since the publication of Zittel's monograph, which forms part of the description of the 'Novara' Expedition ('Foss. Mollusk. u. Ech. aus Neu-Seeland,' Vienna, 1864). That author gave admirable figures and clear descriptions of several species. *Nucleolites papillosus*, Zitt. (*op. cit.* p. 62), is said to be closely allied to the recent species of the New-Zealand seas, *Nucleolites (Echinobrissus) recens*, Edw.

There is no doubt that Breynius described and delineated the genus *Echinobrissus* in 1732, and that Lamarck, being unaware of this fact, founded the genus *Nucleolites* in 1801, to receive, unfortunately, not only true species of *Echinobrissus*, Breynius, but also other species which L. Agassiz subsequently properly associated with the genera *Catopygus* and *Pyrina*. In 1858 Desor endeavoured to separate the genera *Echinobrissus* and *Nucleolites* ('Synopsis des Echinides fossiles,' pp. 257 & 263).

He moreover introduced *Trematopygus*, d'Orb., as a group of *Nucleolites*, with an oblique peristome. A. Agassiz, in revising the genera of recent Echinoidea, had to consider the proper generic title of the two recent species, both of which had been placed under *Nucleolites* by their describers. He retains "provisionally the separation into two genera," and remarks that "from the examination of the scanty material of living species, the splitting of this genus into two sections seems scarcely warranted." He notices that conjugation of the ambulacral pores, which Desor would make a generic attribute, is seen associated with the opposite condition on the same petal in some species, and that it is of no taxonomic value. The shape of the peristome he does not consider to be of much importance; but he thought that the best plan was to let *Echinobrissus* remain as the genus and to permit *Nucleolites* to be a subgenus. It must be conceded that the recent species are aberrant from the genus and the subgenus. Probably future research in the morphology of the recent and fossil species will permanently establish the old genus *Echinobrissus*, Breynius, and will absorb *Nucleolites*, allowing two subgenera to be arranged, so that one can receive the species with an oblique mouth, and the other the species the ambulacra of which have single extra-petaloid pores. It is evident that the Australian species differs from that described by Zittel, but it is interesting to find the persistence of the type through the Australian and New-Zealand Tertiaries to the present Australo-New-Zealand Echinoid fauna.

Zittel's fine drawing of *Hemipatagus tuberculatus*, Zitt.*, indicates, from the separation and incomplete condition of the anterior poriferous zones of the antero-lateral ambulacra, that there was once an internal fasciole present on this form. I have little doubt that specimens will be found which will prove the species to be a *Lovenia*, closely allied to *Lovenia Forbesi*, Woods & Duncan. But the species described as *Hemipatagus formosus*, Zitt.†, appears to be

* Zittel, *op. cit.* p. 63, pl. xii. fig. 1.

† Zittel, *op. cit.* p. 63.

a true member of that genus. Zittel noticed the affinities of this form with the *Hemipatagi* described by Herklots from the Java Tertiaries.

Schizaster rotundatus, Zitt., is allied to *S. ventricosus*, and therefore to the Australian Tertiary form which I have noticed. Zittel has also described a huge *Brissus* (*Brissus eximius*, Zitt.). Unfortunately the species named by all writers on New-Zealand fossil Echinoidea, subsequently to Zittel, are without satisfactory descriptions.

DISCUSSION.

The PRESIDENT remarked upon the importance of recording the nature of faunas from distinct localities, even though the materials at command might be imperfect.

Mr. SLADEN congratulated the Society upon having brought before them such a paper as that just read. With regard to *Clypeaster* and *Echinanthus* he had strong conservative views. *Echinanthus*, he thought, should be confined to Breynius's type. One interesting point in connexion with the 'Challenger' researches he would notice, namely, the occurrence in comparatively shallow water in the Philippines of forms which elsewhere live in very deep water, and this, he thought, might be found to have a bearing upon our views as to the distribution and bathymetrical range of the fossil forms.

Prof. DUNCAN expressed a wish that Mr. Sladen would tell us what conservatism means in this connexion. In many cases when his previous remarks had been criticized by Prof. M'Coy his observations had been founded upon imperfect specimens, although in some instances he could not shelter himself under any such plea.

Mr. SLADEN said that in his opinion Prof. Agassiz was in error in his application of the generic term *Echinanthus*, as the forms he had referred to that genus were not *Echinanthi* at all.

31. *On the LONDON CLAY and BAGSHOT BEDS of ALDERSHOT.* By H. G. LYONS, Esq., R.E., F.G.S. (Read April 27, 1887.)

A RESIDENCE in Aldershot has furnished me with facilities for observing numerous sections and exposures of the Bagshot Beds in the immediate neighbourhood of the North and South Camps, which

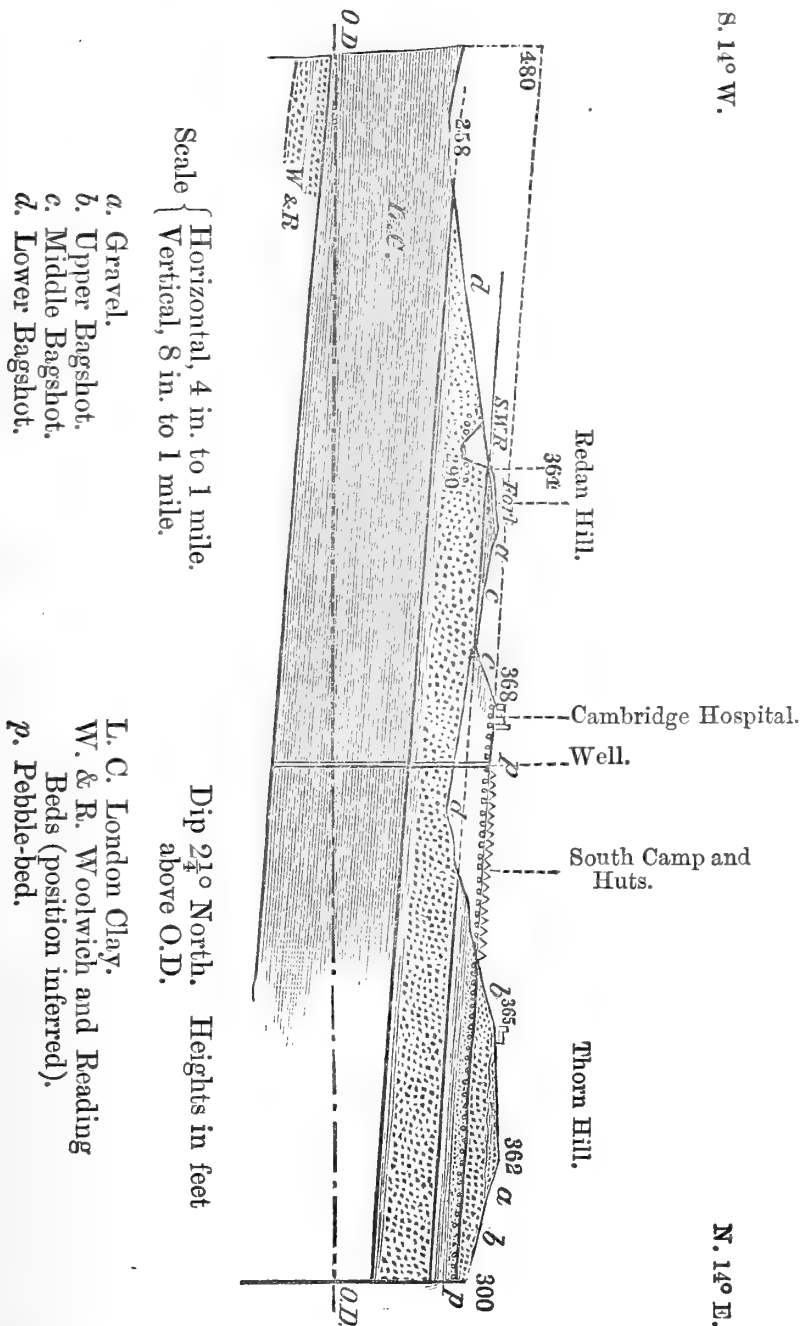

Fig. 1.—Section from Thorn Hill to Redan Hill.

appear to me to bear strongly on the questions relating to the stratigraphy of the Bagshot area which have been raised of late.

I first propose to discuss one particular section which has been very differently interpreted by different observers*.

The section is one through Thorn and Redan Hills to the east of South Camp, and, as shown in fig. 1, is drawn in a direction N. 14° E. and S. 14° W., thus giving nearly the true dip of the beds, which dip slightly E. of N.

Commencing at the North end of the section (which is drawn on the scale of 4" to one mile horizontal and 8" to one mile vertical), the Pebble-bed, which I take as the line of division between the Upper and Middle Bagshot, occurs behind the Commissariat Stores, as described by Mr. Monckton (*loc. cit.* p. 410).

This bed of rolled black flint-pebbles can be traced round the east slope of the hill past the Magazine and the Cemetery, at each of which places it can be seen *in situ*, to the brow of the hill on which the Cambridge Hospital stands. Here the bed has rather thinned and the pebbles are imbedded in a more clayey bed than at the Commissariat Stores.

Walking down the road leading from the eastern end of the Hospital enclosure to the Field Stores in the valley below, we start from the pebble-bed at the top and pass over the outcrop of the different beds of the Middle Bagshot, and then of some of the Lower Bagshot.

The upper portions of the Middle-Bagshot beds are at first sandy, as we see in nearly all the well-sections in the neighbourhood, but lower down they become stiff and clayey, till at the foot of the hill the sandy Lower Bagshots come in. Behind the Field Stores 20 ft. of white, false-bedded Lower-Bagshot sand appear in a sand-pit; and as we ascend the slope of Redan Hill, wherever rifle-pits or shelter-trenches furnish us with sections, yellowish sands of the Lower Bagshot are seen.

A shelter-trench made last summer furnishes a good section of the upper third of Redan Hill, and in it we find exposed, first the yellowish sands of the Lower Bagshot, then clayey beds similar to those passed over in descending the opposite slope of Thorn Hill. These clay-beds extend to the top of Redan Hill till overlain by the gravel capping above them; and I take them to be the lower beds of the Middle Bagshot, which have been raised to this height by the northerly dip of all the Tertiary beds. I will show presently that this is sufficient to do so.

On the south side of Redan Hill these clay-beds are almost wanting, being only seen quite at the top of the railway-cutting, where they are brought out by the northerly dip of the beds. The pebble-bed described by Mr. Irving as occurring in the railway-cutting south of Redan Hill appeared to be a few scattered pebbles occurring at a particular horizon in the Lower Bagshot. Thus there should be no anticlinal between Thorn Hill and Redan Hill as shown by Mr. Irving; and the section as drawn by Messrs. Monckton and Herries in their paper (*Quart. Journ. Geol. Soc.* vol. xlii. p. 412) requires some alteration.

* *Rev. A. Irving, Quart. Journ. Geol. Soc.* vol. xli. p. 502; and *Messrs. Monckton and Herries, Quart. Journ. Geol. Soc.* vol. xlii. p. 410.

Mr. Irving in his paper refers to the green sands of the Middle Bagshot as occurring at the foot of the northern slope of Cæsar's Camp at an altitude of 350 feet. This is 50 feet higher than the top of the Middle Bagshots, as he shows them by his pebble-bed in the railway-cutting. To produce this a synclinal flexure is necessary having its axis in Aldershot town, of which we have no proof. As in fact these green sands are at an altitude of 450 feet, a still sharper bend must be supposed if we admit the Thorn-Redan Hill anticlinal.

Again, the green sand *in situ* occurs at from 500 to 550 feet in Cæsar's Camp and Hungry Hill; and this, coupled with the fact that the Middle-Bagshot beds can be traced from the Canal across the Long Valley up into the flanks of Cæsar's Camp, points to a regular northerly dip.

Now, turning to the same section as drawn by Messrs. Monckton and Herries, we find that, too, to be slightly misleading, though they indeed show the persistent northerly dip of all the beds which, I have shown, is most probable. The difference in level shown between Thorn Hill and Redan Hill is the cause of this; for, as Thorn Hill is 100 feet above the valley, one would assume from the section that Redan Hill was 30 feet below the opposite hill, whereas it is in reality but one foot below it. Again, from the figuring and description of the section, I understand that the authors consider the pebble-bed to represent the Middle Bagshot, and refer all below it to the sands of the Lower Bagshot, omitting the Middle Bagshot clays which occur below the pebble-bed in Thorn Hill in the well-borings and all the surface-sections about, and cap Redan Hill below the gravel.

I will now shortly show how the section in fig. 1 was drawn from the evidence brought forward.

The form of the ground having been plotted from the 6" Ordnance Survey map of 1882, the pebble-bed was put in as follows:—Below the point marked 362 feet, which is the Time-gun, the bed is exposed at 300 feet by the Magazine, a point at right angles to the line of section and 400 yards distant, in an exposure by the Cemetery, and one on the pathway below the Mortuary Chapel; and from these three points, between which the bed can be traced continuously, the line of division between the Upper and Middle Bagshots is drawn.

The thickness of the Middle Bagshot is given by the well-section quoted on p. 434, and by the outcrop of clay-beds on the two hill-slopes from which it was plotted, and found to coincide with the well-section. The London Clay I believe to crop out as shown, as there are two ponds of water lying in this hollow, and the clay is shown in the brickfield on the hill above, where it is overlain by a few feet of Lower Bagshot loam. This also coincides with the well-section. In this section it will be seen that I agree with the Survey mapping, except that I take the top of Redan Hill to be Middle Bagshot, having the whole thickness of the Lower Bagshot beneath it. The Cambridge Hospital and South Camp are shown in elevation, with the pebble-bed forming the surface of the ground.

Section of Well at D Lines, South Camp, Aldershot.

(Surface 340' above O.D., formed by the pebble-bed at the top of the Middle Bagshot.)

	No.	Description.	Thickness.		Total depth.	
			ft.	in.	ft.	in.
Middle Bagshot, 53 feet.	1.	Yellow loam	15	6	15	6
	2.	Green sand	12	6	28	0
	3.	Grey sand	10	0	38	0
	4.	Mixed green sand	6	6	44	6
	5.	Dark green sand	1	6	46	0
	6.	Blue clay, streaky	3	0	49	0
	7.	Blue clay	4	0	53	0
	8.	Black sand	15	0	68	0
	9.	Blue clay	7	0	75	0
	10.	Blue clay	13	0	88	0
Lower Bagshot, 115 feet.	11.	Mixed sand	20	0	108	0
	12.	Bed of stone	6	0	114	0
	13.	Mixed sand	1	0	115	0
	14.	Mixed sand and clay ...	8	0	123	0
	15.	Blue clay	6	0	129	0
	16.	Yellow clay	1	0	130	0
	17.	Sandy rock	5	0	135	0
	18.	Mixed sand	1	0	136	0
	19.	Blue clay	1	0	137	0
	20.	Green sand	5	0	142	0
	21.	Red sand	1	0	143	0
	22.	Mixed sand	5	0	148	0
	23.	Light sand	2	0	150	0
	24.	Blue clay	4	0	154	0
	25.	Mixed clay	2	0	156	0
	26.	Mixed and	6	0	162	0
	27.	Mixed clay and sand ...	3	0	165	0
	28.	„ „ ...	3	0	168	0

The rest is blue clay of the London Clay to 500 feet 4 inches, where sand was met with, and a supply of water obtained rising to 48 feet 6 inches from the surface. In the London Clay, the following layers were passed through at depths from the surface as follows:—

A layer of stone at	ft. 192
„ pebbles at	207
„ „	223
„ „	227
„ yellow stone at	249
„ pebbles at	433

In this well-section the passage of Lower Bagshot into London Clay is remarkable, and is very similar to that shown at Brookwood. The thick development of clay in the Lower Bagshot at beds 9 and 10 in the well-section would seem to furnish a case of a thick lenticular patch of clay in sandy strata similar to that described by Mr. Hudleston at Walton, as no such thickness of clay is found to occur in any surface-sections of the Lower Bagshot round about.

Coming to the instances of, and arguments for, overlap of the Upper beds and erosion of the London Clay which Mr. Irving has put forward, I cannot say that I have been able to make his conclusions agree with the facts which I have collected in this immediate

neighbourhood. I will commence with the section at Ash Station, which he has described lately (Proc. Geol. Assoc. vol. ix. no. 6, May 1886).

As will be seen from fig. 2, we have a spur of the Fox Hills

Fig. 2.—Section from Gravel-pit Hill to Ash Green, S. W. R.

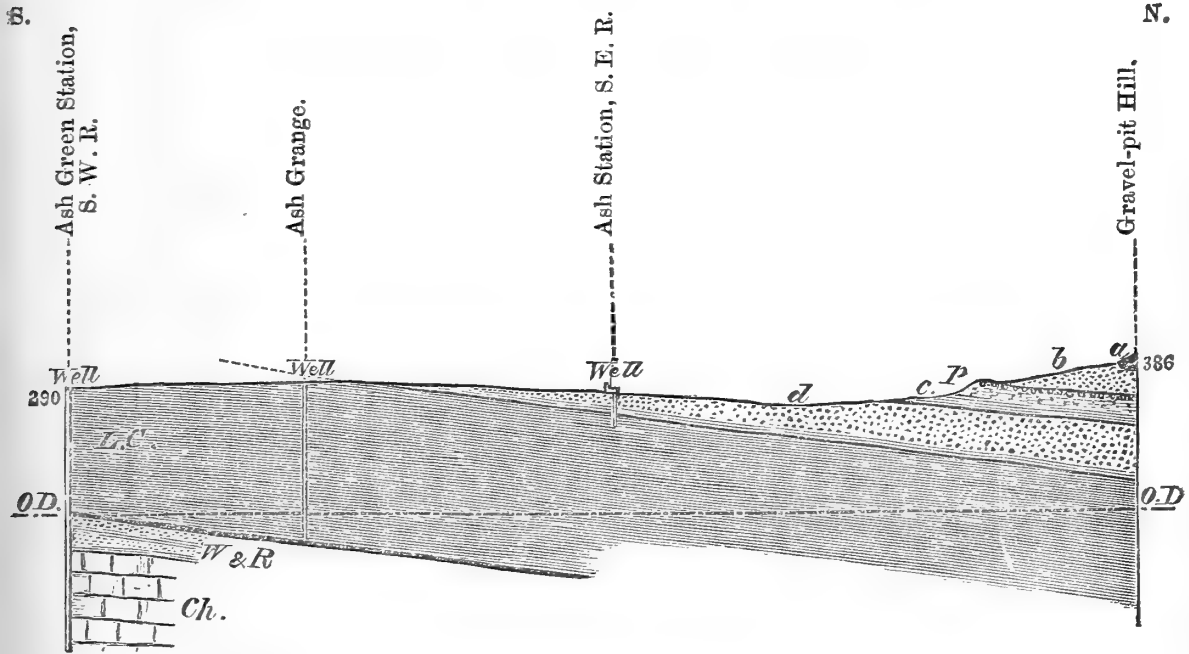

Scale { Horizontal, 4 in. to 1 mile.
Vertical, 8 in. to 1 mile.

Dip $2\frac{1}{4}^{\circ}$ to $2^{\circ} 50'$ at S. end.

- a. Gravel capping.
- b. Upper Bagshot.
- c. Middle Bagshot.
- d. Lower Bagshot.

- L. C. London Clay.
- W. & R. Woolwich and Reading Beds.
- Ch. Chalk.
- p. Pebble-bed.

consisting (omitting the gravel capping) of Upper-Bagshot sand of the normal type till we come to the lower shoulder of the spur, which is capped by the rounded black flint pebbles in great numbers, marking the junction of Upper and Middle Bagshot. In a gravel-pit near Ash Vale they occur in a bed of dark green sandy clay, and, indeed, may be traced for a considerable distance round the foot of the eastern slope of the Fox Hills towards Brookwood. In the lane close by the clay of the Middle Bagshot is seen, and again in the brickfield on the way to Normandy.

Then, at Ash Station, we have the section given by Mr. Irving:—

	ft.
1. Yellow and buff-coloured sand, with occasional iron-stone	48
2. Dark-grey, blackish, laminated clay	7 to 8
3. Dirty greenish sand.....	5 to 6
4. London Clay (blue clay), pierced to	15
	76 ft.

Comparing this with the well-section on page 434, and taking into account the sand, presumably Lower Bagshot, at East-Wyke Farm,

half a mile east, described by Messrs. Monckton and Herries* as occurring beneath the clay-beds of the Middle Bagshots, which I have mentioned above, the arguments already put forward for conformability and constant northerly dip of the beds, and the regular succession of the beds in the Long Valley, I consider the Ash-Station Well to show the basement beds of the Lower Bagshot of a character very similar to those in the Brookwood and South-Camp deep borings. Moreover, the London Clay crops out 1200 feet south on the road leading to the South-Western Station at the same level as the Station. This gives a slope to the north of 61 feet (the thickness of the Bagshot strata) in 1200 feet, or about 1 in 20, which would give $2^{\circ} 52'$, which dip corresponds well with that measured by Mr. Monckton at East-Wyke Farm (Quart. Journ. Geol. Soc. vol. xlii.).

Also, at the South-Western Ash-Green Station, a deep well-boring (Surv. Mem. vol. iv. p. 537) gives London Clay and Reading beds as 370 feet thick. Deducting 80 feet for the Reading beds, we have 290 feet as the thickness of London Clay, 1500 feet from the outcrop, and a slope of 1 in 20, which we have just found above for the overlying Bagshot strata, gives a thickness of 75 feet to be added. A further deduction of the difference in level between the well, 290 feet, and the outcrop 255 feet above O.D., viz. 35 feet, is also required; and thus we have a thickness of 330 feet for the London Clay, which is about the same as that in the South-Camp boring and in the Aldershot Waterworks, as will be shown again later. I therefore consider that there can have been but little erosion of the London Clay at this point before the deposition of the Bagshot beds.

In describing the well-section at Ash Station, S.E. Railway, Mr. Irving (Proc. Geol. Assoc. *loc. cit.*) says, "Here we are about the level of the southern end of the Fox Hills, which consist of undoubted Upper-Bagshot sands." This would account for his drawing the Bagshot beds horizontal in the woodcut there given; but as the well-mouth is over 60 feet below the outcrop of the Upper-Bagshot sands, in order to bring them into the well-section a downward slope of 108 feet in 1800 feet must be allowed, since to the 60 feet given above the 48 feet of yellow sand, called Upper Bagshot in the section, must be added. This gives a slope of about 1 in 17 to the south; and by the well-section and the point of outcrop of the London Clay, we get a slope of about 3° , or, say, 1 in 20 *north* for that formation. Of this Bagshot anticlinal, which is not shared in apparently by the London Clay, I maintain we have no sufficient evidence; and I have already argued against one at Thorn Hill, and shall do so again when describing the section across Aldershot Town. Moreover, the anticlinal here would bring in Middle-Bagshot beds and Upper-Bagshot sands overlying them, dipping 4° south, just about where Messrs. Monckton and Herries have described Lower-Bagshot sands *underlying* Middle-Bagshot basal clays, and dipping about 3° *north*. This appears to me conclusive.

I have quite lately obtained (through the kindness of General Hammersley, of Ash Grange) some details of a deep well in the London

* Quart. Journ. Geol. Soc. vol. xlii. p. 413.

Clay at his house, which is about halfway between the Ash Stations on the South-Eastern Railway and South-Western Railway, and is situated just by the outcrop of the London Clay. The well was deepened to about 300 feet in 1864, before the South-Western Railway Company bored the one close by, which later boring considerably reduced the supply of water in the Ash-Grange well. Thus it seems that the well draws its water from the base of the London Clay, or from the Woolwich and Reading beds; and restoring what erosion has removed, we get a thickness of 320 feet, if the bottom of the well is the base of the London Clay.

The south slopes of the extremity of the Fox Hills, near Ash, give a very good section of the Upper- and Middle-Bagshot beds. Commencing at Ash Vale, we have the pebble-bed, about 2 feet thick in a dark green clayey sand, partly *in situ* and partly reconstructed. The pebbles show considerable current-action, having their longer axes inclined at about 70° . This bed may be traced continuously round the foot of the hills, and occurs cropping out on the hill-slope about the brickfield referred to by Messrs. Monckton and Herries in their account of the Wyke-Lane section. Here, below the pebbles, are sandy beds which furnish with water the springs which are thrown out by the clays at the base of the Middle-Bagshot beds.

The next section I propose to discuss is one across the valley, between Aldershot Town and the Permanent Barracks, and continued on to the Aldershot Waterworks (fig. 3).

The section begins on the top of the hill overlooking South Camp, and as this point is not 300 yards east of the deep-boring at D Lines, described above, I have felt myself justified in plotting the thickness of beds given there at this end of the section. The base of the Middle Bagshot crops out as a clay-bed, at about the 320-foot contour on this line of section; and again some 100 yards to the west it is exposed under Red Hill at the same level. This is slightly below the spot where Mr. Blake is mentioned by Mr. Irving as finding a "sandy bed containing numerous green grains" (Proc. Geol. Assoc. vol. ix. No. 6). This bed I also saw in November last, when this section was opened up by a drain from the beginning of the section to the top of the hill marked 340 (fig. 3). All along this drain the same yellow and buff-coloured sand was exposed, as soon as the Middle-Bagshot beds had been left on the north side of the valley; and a glance at the section will show that this drain was cut in the same portion of the Lower-Bagshot strata, owing to the corresponding dip of the beds and slope of the ground.

These Lower-Bagshot beds crop out on the south slope of the hill behind the brickyard by Aldershot Station, and are exposed in a sand-pit at the top of the hill near the reservoir, as mentioned by Mr. Monckton in a footnote to his last paper.

The dip which I have drawn, viz. $2\frac{1}{4}^\circ$ North, was obtained by several means. First, it can be measured at the top of the hill at the north end of the section, as stated by Mr. Irving (Quart. Journ. Geol. Soc. vol. xli. p. 501), where he describes it as $2^\circ.5$ north; the lines joining the points of outcrop of the Bagshot strata with corresponding points in the South-Camp well give the same, as

also does that joining the base of the London Clay, as given in this well, and the base, as proved in the Aldershot-Waterworks boring. In Proc. Geol. Assoc. *loc. cit.*, Mr. Irving refers to the occurrence of the green bed of the Middle Bagshot at the foot of the northern

Fig. 3.—Section across Aldershot Town.

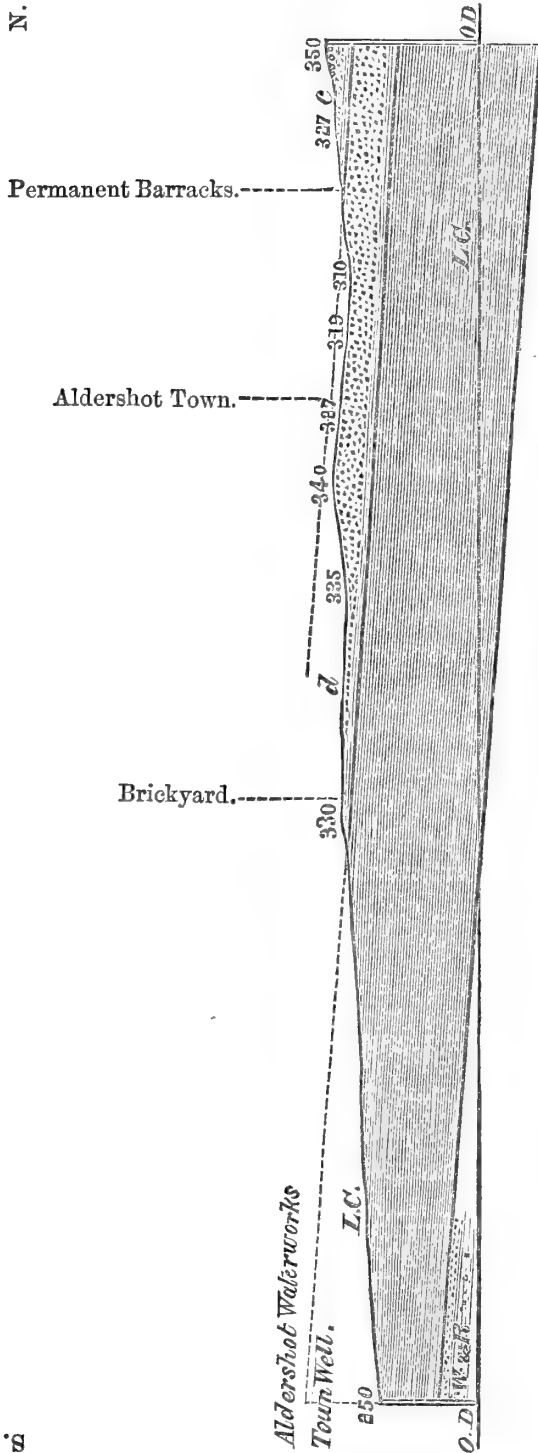

Heights in feet above O.D.
Dip $2\frac{1}{4}^\circ$ North.

Scale { Horizontal, 4 in. to 1 mile.
Vertical, 8 in. to 1 mile.

- c. Middle Bagshot, thickness about 55 feet.
- d. Lower Bagshot, " " 115 feet.
- L. C. London Clay, " " 335 feet.
- W. & R. Woolwich and Reading Beds, pierced to 65 feet at Aldershot Waterworks Well.

escarpment of Cæsar's Camp at an altitude agreeing with that of the beds at Aldershot; and in Quart. Journ. Geol. Soc. xli. p. 501 he describes the same section, presumably as green sands in the rifle-butts, at the height of 350 feet. This must be an error, as the

butts are at 450 feet; and this gives 100 feet above the hill by the Aldershot brickyard, shown in the section (fig. 3), which is capped on the line of the section by some 15 or 20 feet of Lower-Bagshot beds. This 100 feet would bring us into the lower beds of the Middle Bagshot in their natural position, and this disposes of anything unusual in their occurrence at Cæsar's Camp.

Coming now to the London Clay in this section, I have already shown how the base of the clay, as proved in the South-Camp and Aldershot-Waterworks borings, agrees with both the proved and measured dip of the Bagshot Beds; I will now show that the thickness of the London Clay at the latter place is about the same as that at the South-Camp boring, and at Ash, as I have given it above. This I shall do, since Mr. Irving (Quart. Journ. Geol. Soc. vol. xli. p. 507), in his "General Conclusions," No. 6*d*, points to this as a section proving great erosion of the London Clay before the deposition of the Bagshots. Two borings at the Aldershot Waterworks penetrated the London Clay 132 and 134 feet respectively. I will take a mean of 133 feet. The mouth of the well is at 250 feet O.D., and the outcrop of the London Clay is at an altitude of about 340 feet, and is 730 yds. N. Now 730 yds. and a dip of $2\frac{1}{4}^{\circ}$ N. gives a rise of 110 feet; so we have a total thickness of $(133 + 90 + 110) = 333$ feet, which agrees with the deep boring at South Camp (332 feet), and with the thickness at the South-Western Railway Station at Ash (330 feet).

There are two more well-sections which should be mentioned in connexion with this area, namely those given in Geol. Surv. Mem. pp. 445 and 446, as at Aldershot Place. (This I think must be meant for Aldershot Park, as it is called on the 6-inch Survey maps, Aldershot Place being called there "Manor House." The descriptions of the positions and altitudes of the wells agree well with spots in Aldershot Park, but cannot be reconciled with any part of the Manor-House grounds.) When the depths of London Clay found in these borings, namely 151 feet in one and 66 feet in the other, are plotted in connexion with the thickness of London Clay found at the D Lines, South-Camp well, they are found to give a dip of between $2\frac{3}{4}^{\circ}$ and 3° to the N., and a thickness of 330 feet.

Thus we get a thickness of London Clay equal to that at Aldershot Waterworks, South Camp, and Ash, and a dip of the strata intermediate in amount between Aldershot and Ash, between which two places Aldershot Park occupies a nearly central position. The Reading Beds with 76 feet are also of about the usual thickness.

Coming now to Cæsar's Camp and the Long Valley, there is but little of importance besides the occurrence of the green sands at altitudes of from 500 to 550 feet and even higher. The Middle-Bagshot beds can be traced all across the valley, overlain occasionally by Upper-Bagshot sands, with their uppermost limit marked here and there by the pebble-bed.

So far, each section has been discussed to see to what extent it bears out the hypothesis of a constant northerly dip of the beds. I will now shortly describe a section taken from North to South, across the

Long Valley by the Farnborough and Farnham Road. In this section we get the high ground at the south instead of the north end of the section, which is more convenient for our present purpose.

On the tops of the ridges north of the Red Church, near the Permanent Barracks, the pebble-bed occurs at the top of the Middle Bagshot; and a scarped face of one of these ridges nearest to the Red Church shows a section of the base of the green clayey sands and the top of the clay-beds which form the base of the Middle series. Here, when freshly cut, a dip of about $2\frac{1}{2}^{\circ}$ north was shown. Going south, Lower-Bagshot sands were shown in a small excavation by the Queen's Pavilion, and again in a sand-pit behind the Lock Hospital, where there are about 20 feet of brown and buff false-bedded sands, and seams of pipe-clay are seen, having a dip of $2\frac{1}{2}^{\circ}$ north.

Further on, at Windy Gap, on Hungry Hill, the same sands are seen, while the London Clay is dug in a small brickyard at the foot of the hill to the east.

Hungry Hill itself is capped by a considerable thickness of gravel, and below it small springs are thrown out in wet weather, I think by part of the clay-beds which form the base of the Middle Bagshot.

Quite lately, a well 62 feet deep has been sunk at the Inn on the Farnham Road by Hungry Hill, and reached clay having all the characters of the top of the London Clay, having passed through buff and brown loamy and sandy beds. There are 4 feet of water in it.

In extending the drains above the Reservoirs in Bourley Bottom, a bed of green clayey sand was cut into, overlain by a brown loamy clay. This green bed is the one which furnishes all the springs which fill the Reservoirs, and is, I think, the middle bed of the Middle Bagshots, which supplies nearly all the wells in and about Aldershot. The point where it was exposed was between 560 and 570 feet above O.D., under Cæsar's Camp and Bricksbury Hill.

The sand is dark green when first dug out, but becomes light on exposure to the atmosphere.

From these considerations I think that the London Clay and Bagshot beds at Aldershot have a constant northerly dip, and that the Bagshot beds lie conformably on the older beds, which have at this point an average thickness of 335 feet.

In conclusion I will briefly recapitulate the points I have drawn attention to in this paper, and their bearing on the stratigraphy of the district.

Commencing with the London Clay, I have shown that wherever we can fix the top or base of this formation, we get a dip to the north of from $2\frac{1}{4}^{\circ}$ to 3° ; and that this dip, if we restore the portions which have been removed by subaerial erosion, gives us a fairly constant thickness of from 330 to 340 feet. In the table below are given the thicknesses of the London Clay at several places in and near Aldershot; and wherever I have restored what has been eroded away, I have shown it in this table. The authorities for each section are also given.

Locality of Well.	Bagshot Beds.	London Clay. Thickness in feet.			Authority.
		Bored through.	Restored.	Total.	
Dogmersfield Park (Near Odiham) ... }	40	335½	...	335½	Geol. Surv. Mem. vol. iv. p. 446.
D Lines, South Camp, Aldershot ... }	168	332	...	332	This paper.
Aldershot Water- works, No. 1	134	} 200	334	} MS. letter of Mr. Whitaker, Dec. 1884.
Ditto, No. 2	132		332	
Aldershot Park, No. 1	155	175	330	Geol. Surv. Mem. vol. iv. p. 445.
Ditto, No. 2	72	260	332	Ibid. p. 446.
Ash-Green Station, S.W.R.	290	40	330	Geol. Surv. Mem. vol. iv. p. 537.
Ash Grange (Gen. Hammersley's) ... }	...	{ 300 (about)	20	{ 320 (about)	This paper.
Brookwood	170½	371	...	371	Rev. A. Irving, Geol. Mag. dec. iii. vol. ii. p. 353.

Thus we get a fairly constant thickness of the London Clay from Odiham on the west, to Ash on the east, when it thickens to the east at Brookwood.

Moreover, besides the passage from the London Clay up into the Bagshot beds, at the Wellington-College well (Rev. A. Irving, Quart. Journ. Geol. Soc. xli. p. 506), similar passages are shown in the Brookwood well and in the one at D Lines, South Camp, Aldershot; so at these points there can have been no great erosion or great unconformability. The overlying Bagshot Beds too, as I have endeavoured to show, lie conformably on the London Clay and on one another so far as Aldershot is concerned; and the exposure of the Lower London Tertiaries to denuding agencies in Bagshot times cannot have been so near the Bagshot area as Aldershot.

DISCUSSION.

The PRESIDENT congratulated the Society on the acquisition of a recruit whose carefully plotted sections did credit to his training as an officer of the Royal Engineers.

Mr. IRVING observed that the Author had the advantage of being stationed at Aldershot, and expressed a hope that this was merely an earnest of future work on the part of one in whom he could not

fail to take an interest. In consequence of the overwhelming evidence obtained by Lieut. Lyons he accepted his conclusions and gave up his own hypothesis with respect to the section on Redan Hill &c. He had verified Mr. Lyons's reading of that section, and observed that the clays of the Middle Bagshots constituted the most persistent horizon. Where there is a full normal development of London Clay we have a passage into the Lower Bagshots. He was not quite prepared to accept the calculation of 330 feet from the thickness of the London Clay at the Aldershot waterworks. He regretted that we seem no further advanced as to the age of the Kingsclere axis.

Mr. WHITAKER complimented Mr. Irving on having frankly acknowledged his error when it was shown that he had been mistaken. It would, however, be a gratification to him that the correction had come from a former pupil. It was scarcely to be expected that pebble-beds should be persistent over any area; but it was often a matter of surprise how certain thin beds occurred for long distances. He always felt under obligations to those who would correct errors of detail, and hoped that this hint might not be lost upon other officers.

Mr. MONCKTON expressed his obligations to Mr. Lyons, whose paper, in the main, confirmed the work of Mr. Herries and himself. One of their endeavours had been to ascertain if there existed reliable physical differences between the Upper and Lower Bagshots. In this he considered that they had been successful. The Lower Bagshots are characterized by the presence of beds or layers of pipeclay, by abundance of false-bedding, and an absence of shells; in the Upper Bagshots there is no false-bedding, an absence of pipeclay, and usually casts of shells. Applying these tests to the Thorn-Hill—Redan-Hill section, the results were the same as those arrived at from a surveyor's point of view. This work had been admirably done. The clay at the top of Redan Hill had not before been noticed.

Mr. HUDLESTON remarked that, since there was no opposition to Mr. Lyons's reading of the district, it was unnecessary to say anything more in corroboration of a most excellent and original paper.

Mr. HERRIES justified the account of the Thorn-Hill section given by himself and Mr. Monckton, and observed that the clay on Redan Hill was not exposed at the time their paper was written. He had found Upper-Bagshot fossils in Beacon Hill, and also in abundance on the steeple-chase course in the large outlier to the north, thus confirming the Survey mapping.

Mr. LYONS, in reply, cordially acknowledged the advantages he had derived from Mr. Irving's training. Referring to the thickness of the London Clay at the Aldershot waterworks, he showed in detail how the thickness of 330 feet was obtained, and argued for the correctness of his estimate. The extent of the Pebble-bed was most remarkable, and the Geological Survey mapping was good, although the boundaries might require to be altered a little. As regards the passage-beds in the well-section, he did not speak with certainty.

32. SUPPLEMENTARY NOTE *on the* WALTON-COMMON SECTION. By W. H. HUDLESTON, Esq., M.A., F.R.S., Sec. G.S. (Read April 27, 1887.)

1. Recapitulation of some points in the previous paper.
2. Continuation section.
3. Composition of No. 4 Bagshots.
4. Remainder of the cutting.
5. The Brick-earth of Hatch.
6. Its probable Geological Position.
7. Conclusion.

THERE seems to be so much uncertainty as to the character of the basal beds of the Lower Bagshots in the London Basin that any opportunity which affords us unmistakable evidence of their real nature should be seized without delay. We have had so much theorizing, based upon the evidence of well-sections and of limited exposures, that we turn with pleasure to a good continuous section like the one which has lately been disclosed between Walton and Weybridge on the London and South-Western Railway. The main features of the Lower Bagshot series in this section, at its actual junction with the London Clay, were very fully described by me in a communication made to the Society last year. Whether we regard the junction there shown as evidence of an unconformity or otherwise, the fact of a complete lithological change is patent to all.

1. RECAPITULATION OF SOME POINTS IN THE PREVIOUS PAPER.

Resting immediately upon the grey-coloured and sticky London Clay, distinguished by its fine and perfectly regular bedding, is a sharp yellow sand full of current-bedding. This yellow sand I dubbed "No. 1 Bagshots." Then follows the first clay series, which I called No. 2, or the "Blue Bagshots." It is surmounted by a second sandy series, referred to in my previous paper as "No. 3 Bagshots." As far as the new cutting for the widening of the line had then progressed, there was no reason to suppose that No. 3 was succeeded by a second clay series, beyond the fact that the line is rather wet thereabouts. For some reason the contractor left this piece unexcavated, and even now (end of March 1887) this portion has not been fully excavated, so that there are one or two points which cannot be ascertained by actual observation.

The previous sections (Q. J. G. S. May 1886, pp. 148, 157) refer entirely to Walton Common. The one on p. 148 is merely a generalized section of the portion of the cutting then under description, whilst the details of the Lower Bagshot beds given on p. 157 are not continued to the end. Hence the section now offered (fig. 1, p. 445) must be fitted on to the west end of the generalized section, which gives no details of the Lower Bagshot Beds, but merely represents their position with reference to the London Clay and Plateau-gravel.

The generalized section serves to show how deeply the Bagshots are cut into, there being no less than three places where No. 3 is cut through to the level of the line. The spot where the old section actually terminates is a few yards to the westward of the third gap, where the plateau-gravel is of very great thickness.

2. CONTINUATION SECTION (fig. 1).

It is now proposed to carry the original section 300 yards further to the westward. The east end of the new section (fig. 1) coincides with the boundary between Walton Common and Oatlands Park. For the space of 45 yards or thereabouts the pale buff sands of No. 3 Bagshots may be traced beneath the immense thickness of plateau-gravel. When last seen (about the point indicated by the arrow in fig. 1) this sandy series is strongly current-bedded, with a false dip of 7° towards the west. Then occurs a kind of hiatus where nothing is seen but portions of plateau-gravel. Yet a little further on and the clays of No. 4 are well seen on the bank-side, and very soon at least 12 ft. of these beds can be measured on the slope. The actual junction with the presumably underlying No. 3 series is nowhere visible by reason of the extensive denudation which the clay series has undergone towards its outcrop. But evidence of the former extension of the clay series in this direction may be seen in the clayey nature of portions of the material composing the so-called plateau-gravel at this point (*n* in fig. 1). Altogether the evidence is very much in favour of the clay series *resting* upon the sandy series, and *not passing into* it by a process of lateral change, as is stated to be sometimes the case. And there is an additional proof of the truth of this view, that for some distance beyond gap No. 4 the line remains quite dry, as though the argillaceous series, so visible on the slope, did not extend quite down to the level of the permanent way. Presently the effects of the clay begin to be felt upon the line, and throughout the remainder of the section the unballasted portion is a perfect quagmire. The influence of this clay is felt upon the line considerably further than the section extends, owing to the impermeable surface throwing out all the water which percolates the overlying loose sandy series (No. 5). There is an appearance in the upper part of the clay which seems to indicate erosion previous to the deposition of the overlying sandy series (No. 5); but this is doubtful, and in the present state of the section it is impossible to clear up that doubt.

3. COMPOSITION OF No. 4 BAGSHOTS.

Towards the east end thin seams of a pale-coloured loam, resembling the so-called pipe-clay, form the upper part of the series, alternating with brownish sands, which are rather coarser in the grain than those of No. 3. Lower down these seams are observed to be thicker and the clays less bleached. As we proceed westwards the blue beds (4¹) occupy the slope, and the greater part may be described as a

WALTON-COMMON SECTION.

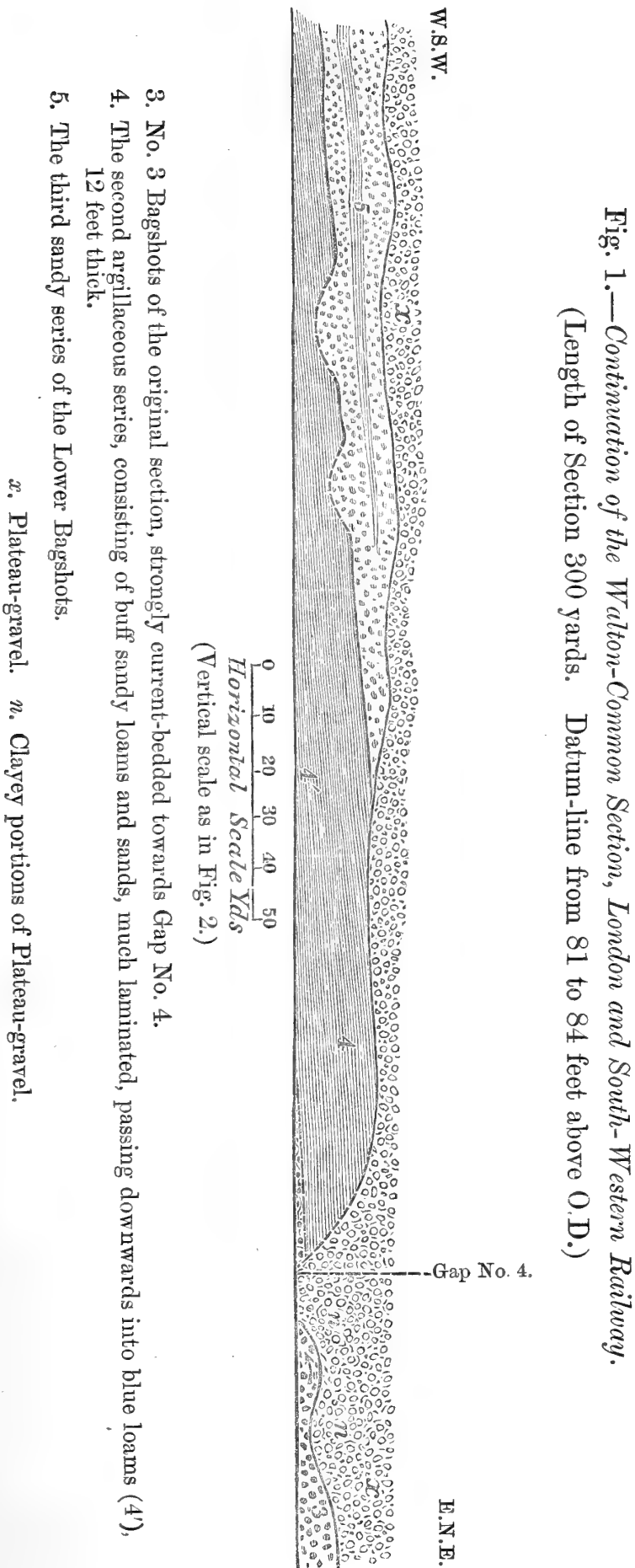

mass of brown laminated loams with blue centres. This constitutes the main exposure, where sandy intercalations are less frequent. The clay is greasy to the touch and behaves like putty when first handled, yet when dried and pulverized it is found to consist very largely of sand, chiefly quartzose, but with a fair proportion of glauconitic granules. Although tenacious and impermeable to a very high degree, it is doubtful whether these beds would constitute a good brick-earth. On the other hand these loams are much sought for by gardeners, as they are evidently possessed of valuable fertilizing properties. The glauconitic granules are much smaller than those of the Middle Bagshots of St. Anne's Hill, which I use as a standard of comparison, and the periphery of the individual grains is less smooth. On the other hand there are fewer fractured granules than were noticed in the lower beds. Thus, whilst in a sample from St. Anne's Hill the grains average $\frac{1}{2}$ millimetre in longer diameter, these grains are certainly less than one fifth. The bluer portions of the beds contain numerous nodular aggregates of sandy pyrites, from 20–50 millim. in length, usually in association with fragments of lignite.

4. REMAINDER OF THE CUTTING.

The portion above described was the last excavated, but the widening of the line has been continued as far as Weybridge Station, and the works are now completed between Walton and Weybridge Stations. As far as Haine's Bridge (mentioned in the previous paper), the series No. 5 maintains its character as fine buff sand with clay laminations, and is not to be distinguished lithologically from No. 3 series. In fact these two series are certainly typical of the Lower Bagshots of this district, and both of them must be of considerable thickness. The base of the clay series No. 4 may be about 40 ft. above the London-Clay surface, but this depends very much upon the behaviour of No. 1, the very false-bedded series. Above No. 5 I have not succeeded in distinguishing any series at present, because, west of Haine's Bridge, the exposures during the widening were not of a clear nature, owing to the methods of working adopted. Bright yellow fine-grained sands, similar to those so well known between Weybridge Station and the river Wey, are seen for the most part; still it is certain that even in this portion of the cutting there occurs a certain proportion of argillaceous beds. The precise mode of development of these Lower-Bagshot clays could not be ascertained, but I was led to suspect that they form small basins of argillaceous matter in the midst of the sands. The exposures between Haine's Bridge and Weybridge Station would lie in the very heart of the Lower Bagshots, here estimated by Prestwich at 130 ft. in thickness.

5. THE BRICK-EARTH OF HATCH.

Thus far we have felt our way carefully, and the sequence of the Lower Bagshots in the railway-cutting may be regarded as

settled up to a certain point. Henceforth, if we would further endeavour to study the development of the Lower Bagshots of this part of West Surrey, it will be necessary to take a leap more or less in the dark. We leave the positive for the inferential, and, what is more, we find ourselves in collision with the Geological Survey as represented in their mapping of the ridge known as Woburn Hill between Addlestone and Chertsey (sheet 8 of the solid geology and surface geology of London and environs). This Woburn Hill, or Woburn Park, as it is sometimes called, constitutes a promontory of Bagshot Beds, about 90 ft. above O.D., projecting into the great mass of alluvium and valley-drift at the junction of the Thames and Wey, which takes place about 30 ft. above O.D. The ridge is about two thirds of a mile in length from E.N.E. to W.S.W., and the upper portion is composed of a very stiff clay, which has been worked for a considerable period towards its western extremity at Hatch Farm. This forms a portion of the "clays most extensively developed round Addlestone and Chertsey, where they attain a thickness of 10 to 20 feet," referred to by Prof. Prestwich* as constituting part of his Middle Bagshot beds. It is not to be denied therefore that the mapping of the Survey in respect to Woburn Hill has the sanction of the great pioneer of Tertiary geology in the London basin. Before proceeding to express my doubts on this point, and also before proceeding in the attempt to define what should be regarded as Middle Bagshots in this part of West Surrey, I propose to give a description of the

Hatch-farm Clay-pit (fig. 2, p. 448).—The pit is practically a transverse section of the west end of the top of Woburn Hill. We perceive at once that the brick-earth does not occur as an ordinary seam of clay parallel to the underlying sand, but that it occupies a basin-shaped hollow in that sand. There is, in fact, every reason to suppose, from the upward curve of the underlying series, that we simply see the transverse section of a lenticular mass of clay, which on the north is truncated by the escarpment, but towards the south has the appearance of going out altogether. Another feature in the brick-earth is the remarkable amount of current-bedding with a prevailing southerly dip, towards the centre of the hollow, in fact; whilst further south, where the hollow in the sand is less pronounced, the laminations are almost horizontal.

The clay of this pit is pretty strong, being used for making red bricks and stock bricks, whilst the presumably Middle-Bagshot clays of Ongar Hill, worked by the same proprietor, are also largely used for pipes and tiles. The blue portions of the clay are full of flattened pyritous lumps of a different shape from those previously noticed in No. 4 of the Oatlands-Park cutting, and there is an abundance of microscopic crystalline aggregates of pyrites and some very fine quartz-grains. Carbonaceous matter is plentiful throughout, but glauconitic granules are scarce in all examples examined by me. The hill itself forms one of the stiffest clay soils known in this part of the country.

* Q. J. G. S. vol. iii. p. 383.

Fig. 2.—Section in Hatch-Farm Clay-pit, Woburn Hill.

(Length of Section 160 yards. Datum-line about 60 feet above O.D.)

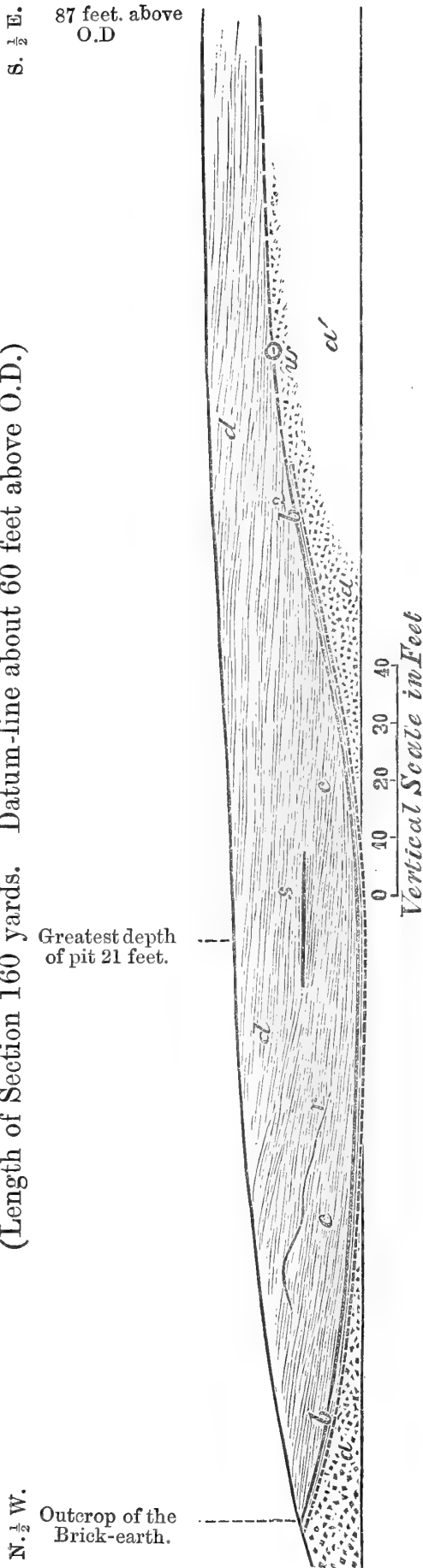

- a. White sand with occasional clay laminations; *a'*, the same as proved in the well.
- b. Undulating base of the Clay-series in sandy laminations hardening into a pan at top, on which the Brick-earth rests. The floor of the pit is mainly on this pan, which at the point *b*² has an inclination to the north of 7°-10°.
- c. Dense blue brick-earth (loam).
- d. More laminated portions of the Brick-earth, brownish, extremely false-bedded on the left, more horizontal and more interbedded with sand on the right.
- r. Irony and carbonaceous layer in connexion with false-bedding.
- s. Coaly line dividing the laminated buff clays from the dense blue clay with pyrites.
- w. Level of mouth of well, not in line of section.

6. PROBABLE GEOLOGICAL POSITION OF THE HATCH BRICK-EARTH.

In attempting to fix the position of this remarkable loam, or brick-earth, we must first arrive at an understanding of what is meant by Middle Bagshots. A casuist might argue, because Prof. Prestwich speaks of the clays between Addlestone and Chertsey as forming the base of the Middle Bagshots, that in point of fact these must belong to the Middle Bagshots, whatever the position of other beds assigned to that series may be. As a mere logical crux, there may be something to be said for this view of the case; but geologists will have no difficulty in admitting, if the basal beds of the Middle Bagshots can be shown to occur on a higher horizon in this district, and if such beds have been recognized, both by Prof. Prestwich and the Officers of the Geological Survey, as forming the base of the Middle Bagshots, that in that case we must take the beds usually accepted as the base of the Middle Bagshots for our standpoint, and then see if the Hatch brick-earth or loam can be brought into alignment with them.

Along the line of the London and South-Western Railway it is clear, according to the meaning both of Prestwich and the Survey, that the brick-earth (loam) worked on St. George's Hill forms part of the basal beds of the Middle Bagshots—there 170 ft. above O.D. But the type section must be sought in the cutting on Goldsworthy Hill, where Prof. Prestwich describes the basal beds of the Middle Bagshots as foliated clays, more or less sandy, having a thickness of 14 feet and resting on 130 feet of "Lower Bagshot Sands."

We are not now discussing the question as to what are the best divisions for the Bagshot series of the London basin taken as a whole. The real issue to be decided at present is whether the Hatch brick-field is in alignment with the basal beds of the Middle Bagshots as defined by Prestwich in the Goldsworthy cutting; if it is below that horizon it should be mapped as part of the Lower Bagshots notwithstanding its argillaceous character*. I am disposed to think that it does lie below the basal beds thus defined, and moreover that it differs somewhat in character from the basal beds of the Middle Bagshots as seen in the clay-pit on St. George's Hill.

The considerations for determining the point at issue are partly stratigraphical and partly lithological. We must not, I admit, place too much reliance on the latter, considering the variable and uncertain nature of such accumulations. I would merely indicate that the general character of the standard basal clays of the Middle Bagshots is much more regular, there is less of such very accentuated false-bedding, and the material is more frequently of the nature of a pipe-clay. At the same time there are certain well-known features common to all Bagshot clays, such as their loamy and laminated character, abundance of carbonaceous matter, and other conditions, all pointing to considerable similarity in origin. Hence we must

* It may perhaps be a legitimate question how far physical peculiarities should determine the mapping of a series. If by Lower Bagshots it is intended to represent sandy beds, and by Middle Bagshots loamy or clayey beds, then Woburn Hill is correctly mapped. But although this arrangement is suitable to the economy of the case it cannot be satisfactory to geologists.

not expect the lithological contrasts to be strong or reliable in all cases. The standard basal clays of the Middle Bagshots are nothing more than a repetition on a higher horizon, and over a more extended area, of argillaceous conditions which have obtained from time to time throughout the so-called Lower Bagshots.

The stratigraphical aspect of the question, as to the geological position of the Hatch brick-earth, presents more material for our consideration, though I am willing to admit that the evidence presently to be adduced is not absolutely conclusive. Before venturing on a diagrammatic section across country, let me recall one or two facts in connexion with the Clay-pit. The lenticular character of the deposit is obvious. The base may be taken at 60 ft. above O.D. where the mass is thickest, and this is about 25 ft. above the general level of the Thames at Chertsey. There is a well commencing in the underlying sand, the mouth of which is about 75 ft. above O.D. This well is said to be 35 ft. deep, all in sand, and had 9 ft. of water in January 1887. This makes the water-line in that part of Woburn Hill 14 ft. higher than the general level of the Thames at Chertsey. Such indications point to the probability of clay at no great depth from the bottom of the well, since the well can hardly be deep enough to reach the valley-water. At the same time I lay no very great stress upon this conclusion; first, because the various levels have not been ascertained with absolute accuracy, and, secondly, because, in a Bagshot country, the water is often held up so curiously and so capriciously as to make us shy of drawing conclusions therefrom.

Leaving the question of water-lines, let us consider how far the general question of levels helps us to fix the position of the Hatch brick-earth. With this object I now venture on a diagrammatic section (fig. 3, p. 453). From St. Anne's Hill to the northern brow of St. George's Hill is a distance of 5 miles, N.W.—S.E. St. Anne's Hill is 230 ft. above O.D., and the north brow of St. George's Hill is 245 ft. above O.D. Woburn Hill is just midway, with an elevation of 92 ft. as a maximum. The position of the recognized basal beds of the Middle Bagshots is very well known on St. George's Hill, and may be placed at about 170 feet above O.D. The actual position of these same beds at St. Anne's Hill is not quite so clear; but from general considerations I am disposed to regard this hill*, in its normal and unruined condition, as having the following composition:—

* It is evident that opinions as regards this hill have varied at different times. It owes its existence to an unusually thick deposit of Bagshot pebble-gravel, which occurs quite at the top of the hill and presumably at the junction of the Middle and Upper Bagshots. These pebbles are sometimes welded together as a very hard conglomerate, and both this and the loose pebbles have been tumbled about in every possible direction. St. George's Hill, on the other hand, is quite different in shape, and owes its origin to a strong deposit of the older plateau-gravel.

It is admitted that the fixing of the line of the London Clay on St. Anne's Hill is somewhat arbitrary, and seems rather opposed to the results of the sinking for water at the Holloway sanatorium (Whitaker, *op. cit.* p. 66). But as we read of passage-beds (?) into the London Clay, there is evidently an element of uncertainty in the Report.

Reputed Middle Bagshots	feet. 60
Lower Bagshots	120
London Clay	50
	<hr/>
Total above O.D.	230

This calculation brings the base of the Middle Bagshots in St. Anne's Hill to 170 ft. above O.D.—a level almost identical with that on St. George's Hill. Making due allowance for errors and miscalculations, we may safely say that the levels are within 15 ft. of each other.

A glance at the diagrammatic section (fig. 3) at once makes us inquire why, if the basal beds of the Middle Bagshots lie so high up on St. George's Hill and on St. Anne's Hill, they should have descended so low in Woburn Hill, which lies between the two. In other words, is the mapping of Woburn Hill as Middle Bagshot justified?

The chief point for our consideration is whether there exists any evidence of a trough between St. George's Hill and St. Anne's Hill, produced either by an ordinary syncline or by erosion of a pre-Bagshot surface. If there is no evidence of such a trough, then, on stratigraphical grounds, the Hatch brick-earth must be a member of the Lower Bagshots. I am quite prepared to admit the existence of some peculiarity hereabouts, because the Thames suddenly changes its mean direction just opposite Woburn Hill, recovers its former course for a few hundred yards, and then suffers final deflection to the E.N.E. The confluence of the Wey and the Thames marks the most southerly point attained by the principal river; and no doubt the causes which induced and afterwards arrested the southerly course of the Thames are to be sought in the nature and disposition of the beds in this immediate neighbourhood. The Thames was probably drawn southwards by the fall in the London-Clay surface, since it was much easier to eat away the loose sands of the Lower Bagshots than the strong blue clay on which they rest. Hence the most southerly point of the Thames valley probably coincided with the maximum depression of the London-Clay surface on the flanks of the main valley. But the cap of clay on what is now Woburn Hill helped to keep together the incoherent sands beneath; so that we perceive St. Anne's Hill, Woburn Hill, and St. George's Hill are primarily caused by a capping of tenacious material which is of an entirely different nature in each case.

We are quite prepared for a synclinal, then, if it can be proved to exist; but at present I have not been able to obtain evidence that such is the case, at least not to the extent necessary to bring the Woburn-Hill beds into alignment with the basal beds of the Middle Bagshots. At the same time, there can be no doubt that the fall of the Bagshot base between Walton Common and the River Wey is considerable. Thus at the eastern extremity of the formation in this district, 658 yards west of Walton Station, the Bagshot base is 85 ft. above O.D., whilst near the railway-bridge over the Wey it

cannot well exceed 30 ft. above O.D., and may be less. We have, then, a fall of say 55 ft. in $2\frac{1}{4}$ miles in a direction from E.N.E. to W.S.W., which serves to show that the London-Clay surface falls at the rate of 1 in 216 throughout the portion traversed by the London and South-Western Railway, between the above-named points. There is also additional evidence that the London-Clay surface continues to fall very slightly still further down the line, since the Bagshot base at Brookwood is $21\frac{1}{2}$ ft. *below* O.D.*. But the above considerations will only slightly affect a line drawn from St. George's plateau to St. Anne's Hill (fig. 3), which is nearly at right angles to the direction of the main L. & S.W. Railway.

Hence, we are not entitled to assume the existence of a marked synclinal in the position occupied by Woburn Hill on the evidence above stated; whilst, on the other hand, if there be no synclinal, the ascertained position of the recognized basal beds of the Middle Bagshots in the district is very much against the notion that the Woburn-Hill Clay (Hatch brick-earth) should be on their horizon. At the same time I am ready to admit that the base of the Ongar-Hill brick-earth, about two miles on the other side of Addlestone, which apparently must be correlated with the recognized basal beds of the Middle Bagshots, cannot be much more than 100 ft. above O.D.; but even this is fully 40 ft. higher than the base of the Hatch brick-earth, and more in the direction where the Bagshot base is undoubtedly falling †. Altogether, it must be considered that if the Hatch brick-earth belongs to the Middle Bagshots, as indicated on the Survey Maps, there must be an exceptional condition of the local stratigraphy. In point of fact we are faced by the following difficulty:—Seeing that the base of this brick-earth is about 60 feet above O.D., and assuming that the Lower Bagshots retain their average thickness of 120 ft., we should have the London-Clay surface 60 ft. *below* O.D. at this point. It is for those who maintain that this brick-earth belongs to the Middle Bagshots to bring proof of this.

Even in the actual valley of the Thames there is no instance that I know of, on the Surrey side, where the London-Clay surface sinks below O.D. At Chertsey, in the heart of the Thames-valley “shingle,” the London-Clay surface does not fall below Ordnance Datum, though it approaches very near it. At the brewery, where the well-mouth is probably 44 ft. above O.D., this happens to be the exact thickness of the superficial beds, thus:—

Surface-mould and loamy clay	ft. 5
Gravel and sand	35
Dark sand	4
—	
Total of beds above London Clay	44 ‡

* W. Whitaker, ‘On some Surrey Wells and their Teachings,’ p. 47.

† The clay beds at Ongar Hill and the adjacent Row Hill afford a remarkable instance of the development of argillaceous beds in the Bagshot system, which seems to point to considerable variation in their volume and importance even on a well-recognized horizon.

‡ Whitaker, *op. cit.* p. 49.

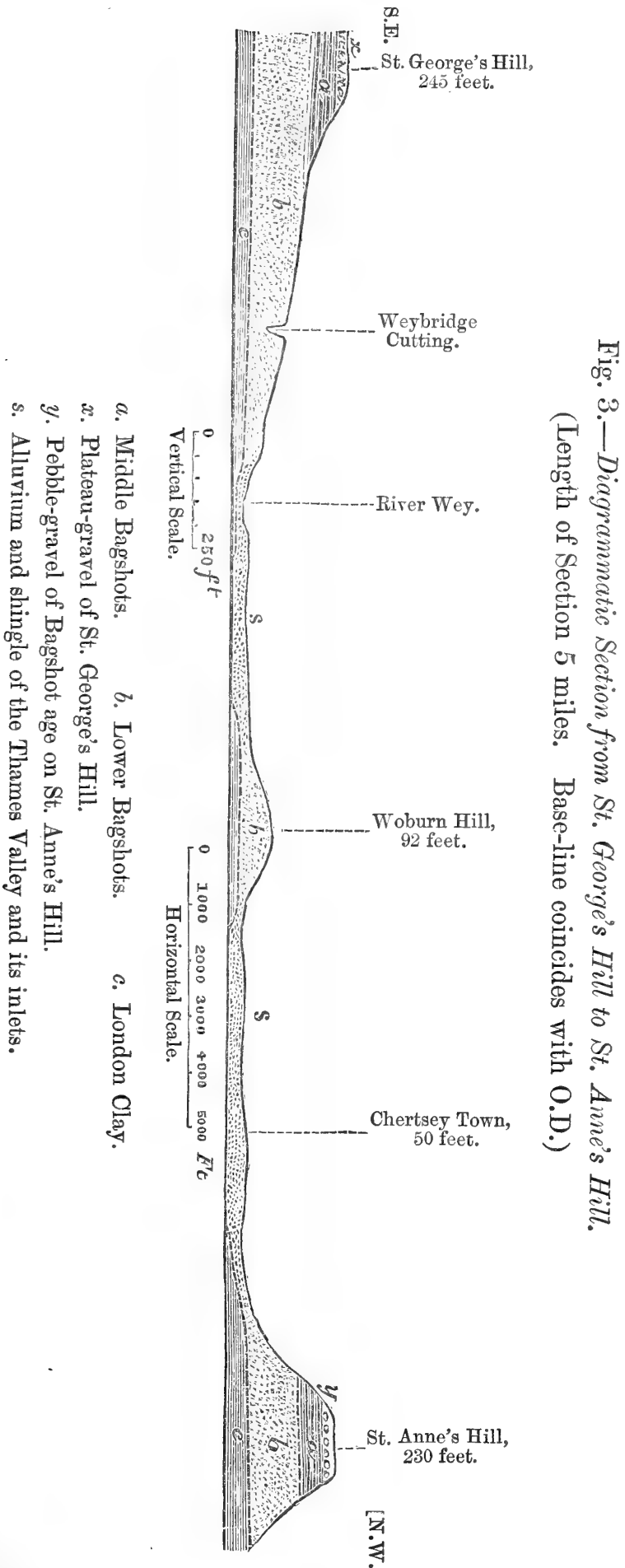

Fig. 3.—*Diagrammatic Section from St. George's Hill to St. Anne's Hill.*
(Length of Section 5 miles. Base-line coincides with O.D.)

Hence at Chertsey the London-Clay surface almost coincides with the Ordnance Datum. At the junction of the Wey and Thames I have no record, but the well-sinker at Oatlands (Mr. Gray) considers that the "blue clay" will not be quite so low there as at Chertsey. At West Molesey the London-Clay surface is 7 ft., and at Thames Ditton, 14 ft. above O.D. If these places in the valley of the Thames itself fail to afford a London-Clay surface below O.D., how much less likely is it that the flanks of that valley should do so? Unless there are exceptional circumstances, of which we have no proof, I should be disposed to run the line of junction between the London Clay and the Bagshot beds in Woburn Hill at from 20 to 30 ft. above O.D. The effect of this would be to bring the Hatch brick-earth comparatively low down in the Lower Bagshots, and pretty nearly on the horizon of the clays distinguished as No. 4 of the Walton-Oatlands cutting. Not that these two deposits are by any means to be regarded as continuous, since all the evidence goes to show that clays occur in an irregular and sporadic fashion throughout the sandy beds of the Lower Bagshots.

7. CONCLUSION.

It may be asked why so much importance should be assigned to the position of these Bagshot clays, or, to put it more plainly, why a particular brick-earth should be relegated to the Lower rather than to the Middle Bagshots.

There are two principal answers to this question. *First*, that we should not neglect any opportunity of studying the Lower Bagshots of the London Basin, with a view to ascertaining their composition and development throughout the district. The term "Lower Bagshot Sands," applied by some people, is thoroughly misleading, as lithological terms usually are in such cases. But altogether apart from the question of nomenclature, there arises a desire to possess a more complete knowledge of these curious beds. The more they are studied under favourable opportunities and without prejudice, the less we shall hear of a passage between a uniform deposit with marine organisms, like the London Clay, and the irregular, current-bedded sands, loams, and clays which constitute the beds usually known as the Lower Bagshots. At present we really know very little of the junctions between the London Clay and the Bagshot Beds; since those of well-sections are not very satisfactory, owing to the different appearance which the same beds are apt to present under a different state of oxidation, and also, in some cases, to the unfitness of those who have to prepare the sectional reports.

The *second* answer to the inquiry, as to the utility of these investigations, is mainly derived from the following consideration, viz.: that, until observers fairly realize the existence of important masses of clay and loam in the division usually known as the Lower Bagshots, we shall be continually finding beds referred to the Middle Bagshots which stratigraphically do not belong to them.

In this way a species of speculative stratigraphy is encouraged, which has no real foundation except in similar misconceptions. Thus, true progress towards a correct understanding of the history and constitution of the London Basin is retarded.

With reference to the subject of mapping, if it is proposed that all argillaceous outcrops shall be coloured as Middle Bagshots, that is a question which must be settled elsewhere. But if this is the view taken by the authorities in charge of these matters, it obviously implies a reclassification of the entire Bagshot system.

DISCUSSION.

The PRESIDENT congratulated the Author on the light he had thrown on the relations of the Eocene beds near Weybridge. He thought that the lenticular character of the beds of this age in both the Hampshire and London basins had been clearly shown.

Mr. WHITAKER said Mr. Hudleston's section of the Hatch-Farm Clay-pit suggested a synclinal, though probably the hollow was one of erosion.

The junction of the London Clay and the Bagshot Beds in the Walton-Common section was singularly abrupt; as a rule those formations passed into each other. The term Bagshot Beds was preferable to Bagshot Sands, for the character varied. There was more clay to the west, in the Hampshire Basin, and especially in Dorsetshire.

Mr. IRVING gave some details of a section at Highclere to show the transition between London Clay and Bagshot. The section through Woburn Hill, if drawn to true scale, would show the synclinal to be very shallow. The Hatch section appeared to be a mere case of "contemporaneous erosion and filling up."

Mr. HERRIES said he had seen no clays in the Bagshot Beds like those of Woburn Hill; but they resembled the basement bed of the Middle Bagshot more than any others. He was, however, inclined to think Mr. Hudleston's conclusions were right, but thought judgment should be suspended till the nature of the upper part of the hill was known. It had been said that the chalk surface and the beds above it were irregular; if so, there might be a local synclinal here, quite distinct from the general basin-shape of the district. Again, clay conditions might have set in earlier here, so as to cause a great development of Middle-Bagshot clays at the expense of the sands of the Lower Bagshot. He agreed with Mr. Hudleston's view of the Walton-Common section.

Mr. HUDLESTON said the suggestion of a great development of Middle Bagshot was difficult to prove or disprove. The curve made by the Thames at this point might, however, be due to a depression of the Bagshots. The presence of passage-beds in a different district, as described by Mr. Irving, did not necessarily throw any light on the conditions prevailing near Weybridge. In some cases the clays of the Lower Bagshots might have been mistaken for London Clay.

If the London Clay passed into the Bagshots there was an end to the unconformity for which Mr. Irving contended.

Mr. IRVING said, in explanation, that he had only argued that there was unconformity on the margins of the area. The case he had mentioned confirmed the well-sections he had previously quoted. There is no such passage in the surface-sections on the north side.

Mr. HUDLESTON was glad Mr. Whitaker thought that the Hatch brick-earth on Woburn Hill might be Lower Bagshot, and heartily agreed with his objections to the term Bagshot Sands.

33. *On NEPHELINE-ROCKS in BRAZIL, with SPECIAL REFERENCE to the ASSOCIATION of PHONOLITE and FOYAITE.* By ORVILLE A. DERBY, Esq., F.G.S. (Read June 22, 1887.)

THE nepheline-rocks heretofore recognized in Brazilian territory are the phonolites and associated basalts of Fernando Noronha, a deep-sea island off the north-eastern shoulder of the continent, in lat. $3^{\circ} 5' S.$, long. $32^{\circ} 24' 19'' W.$, the volcanic nature of which appears to have been first recognized by Darwin in the 'Voyage of the Beagle'*. Recently a single small pebble from the little-known island of Trindade, in lat. $20^{\circ} 31' S.$, long. $29^{\circ} 19' W.$, has come into my hands, showing that phonolite of somewhat different character from that of Fernando Noronha occurs at that place also.

Recent investigations have shown that nepheline-rocks of a somewhat different character are also abundantly developed on the mainland, and in such favourable conditions as to throw light on the relations of the granitic type of foyaite or elæolite-syenite to the other members of the group. The localities in which they have thus far been recognized are situated in the Provinces of Rio de Janeiro, São Paulo, and Minas Geraes, and their relative position and relation to the main orographic lines of the region in which they occur are shown in the accompanying sketch map (fig. 1). Three of these localities, Campo Grande, Cabo Frio, and the peak of Tingua, are in the immediate vicinity of Rio de Janeiro, the latter being in the Serra do Mar range, the two former among its foot-hills. Further south another set of localities occurs in the same range in the valley of the river Iguapé. In the Mantiqueira range the peak of Itatiaia (3000 metres high, and the highest mountain of eastern South America) and one or more other high peaks in the neighbourhood are composed of these rocks, which occur also in the Serra do Bocaina, a spur of the Serra do Mar range on the opposite side of the Parahiba valley. The other two localities are the Pocos de Caldas (hot springs), on the southern margin of the great westward expansion of the mountainous area which connects the coast range through the Serra do Canastra with the central range of Goyag, and Itambé in the Serra do Espinhaco range, a northward extending branch of the Mantiqueira. As little more than a year has elapsed since attention was first directed to these rocks, and as the first knowledge of their existence in these different localities was obtained almost casually, it may reasonably be supposed that

* A few of the Fernando-Noronha rocks are described by Renard (Bull. de l'Acad. de Belgique, iii. 1882). A very complete collection made by Mr. J. C. Branner for the Geological Commission of Brazil has been placed in the hands of Prof. G. H. Williams for study.

from analogy with other places examined, there should be somewhere in the neighbourhood some central mass from which these dykes of phonolite, trachyte, and basalt radiate; and an examination of the hills in the vicinity will probably reveal such a centre. It is possible, however, that they should be referred to the eruptive mass of the peak of Tingua, which is about 20 miles distant. Here only the lower portion of a single spur has as yet been examined; this is composed of foyaite similar to that of the principal mass of Cabo Frio, resting upon gneiss. That it has not the character of a dyke in the place examined, is proved conclusively by a tunnel some 400 metres long, which has been cut through the spur from side to side. Gneiss, cut by small dykes of basic rocks, occurs throughout the tunnel and for a few metres above its mouth at both ends, but the surface of the spur above the line of the tunnel is occupied exclusively by foyaite. Small dykes of basalt similar to those of Campo Grande and of a trachytic rock occur; but thus far they have only been seen in the gneiss. The only phonolite seen is in a large boulder or projecting point in the midst of a foyaite area; it presents the appearance of a dyke about two metres wide, with a sharp line of demarcation between it and the foyaite, which adheres to both sides. The phonolite is thickly spotted with inclusions or segregations of foyaite similar to that of the sides, of all sizes up to an inch or more in diameter. The cross sections of these inclusions show a tendency to geometrical forms, appearing like sections of crystals*. The appearance is that of a dyke which had caught up fragments of the enclosing rock; but the regularity of the distribution of the inclusions and their similarity of form is against this view, while, on the other hand, the phenomena to be described below from the Caldas locality make it seem plausible to suppose that the phonolite is a portion of the original magma that has escaped complete crystallization, and that the inclusions are crystallized segregations in the midst of it. A petrographical study will doubtless determine which view is correct.

The great mountain mass of Itatiaia, rising about 2500 metres above its base, is made up for the most part of a variety of foyaite which has more of the granitic aspect than the prevailing rock at Tingua and Cabo Frio, and which has only been met with in a subordinate mass at the latter place, referred, as already stated, to nepheline-bearing augite-syenite by Prof. Rosenbusch†. Foyaite of the ordinary type is also known to occur there, as likewise an aphanitic rock, which may be considered a phonolite or a fine-grained foyaite. As the excursion to this peak was made before my attention was drawn to the group of rocks here considered, many other types doubtless passed unnoticed. The neighbouring

* A similar inclusion of foyaite in the phonolite of Fernando Noronha was found in a specimen from that place, when no large masses of foyaite were met with in a careful examination of the island. Prof. Rosenbusch, to whom a chip was submitted, regards it as an included fragment of an older rock.

† A specimen of this rock given to Mr. Henry Bauer, of Iguapé, was sent by him to the late Prof. Lasaulx, who described it in a recent number of the 'Sitzungsbericht der niederrheinischen Gesellschaft,' Bonn. This is the first published notice of the occurrence of these rocks in Brazil.

peak of Picú is known, from specimens collected in the bed of a stream flowing from it, to contain a variety of types of foyaite and other nepheline-bearing rocks; and another prominent peak, called Itajubá, in the same vicinity and in the same range is, judging from its topographical features, of similar structure. The Bocaina locality is only known to me by a specimen of foyaite brought from there some years ago by the director of the National Museum when on a botanical excursion.

The Iguapé region is only known to me through specimens kindly furnished at various times by a German engineer, Mr. Henry Bauer, who has given considerable attention to the collection and study of the rocks of his district. They include several peculiar types not yet known from other localities; and suspecting that they were associates of foyaite, I requested Mr. Bauer* to search for that rock, which he has recently found at a place called Jacúpiranga. Nepheline-bearing rocks also occur in the vicinity of Xiririca further up the valley, and there are reasons for supposing that a number of other localities will be found in that region. The Itambé locality is only known by a specimen in the National Museum of Rio de Janeiro, sent many years ago by the German geologist Eschwege, under the name of diorite, and which is pronounced by Prof. Rosenbusch to be a fine example of nephelinite.

A cursory examination of some of the localities above mentioned having shown an apparent and hitherto unsuspected relation between foyaite, phonolite, trachyte, tuff, and certain types of basalt, I determined to visit the Caldas region, from which a specimen intermediate in character between foyaite and phonolite had come into my hands, and where a railway under construction gave unusual facilities for examining this series, while the proximity of a sedimentary formation of palæozoic age gave hopes of obtaining some idea of its geological age. A splendid development of foyaite, phonolite, and tuff was found associated with several types that have not yet been met with in the other localities. The tephritic basalts which characterize the other places are represented by leucite-basalt and by a peculiar rock having the external aspect of a diabase, in which plagioclase is the predominant element, and which I suspect will prove to be teschenite. Trachytes, if represented, only appear in dykes too much decomposed for accurate determination.

The Mogyana railway, starting from Campinas in the province of São Paulo, runs near the margin of the mountainous plateau of southern Minas Geraes and the sedimentary plateau of São Paulo. The former, composed of gneiss and metamorphic schists, has a mean elevation of from 1000 to 1200 metres; the latter composed of horizontal strata of shale, sandstone, and limestone, cut by numerous and large dykes of diabase, varies in elevation between 600 and 1000

* Among the rocks sent me by Mr. Bauer is olivine-basalt (limburgite). In the other two localities in which it is known (Campo Grande and Tingua) it occurs also in connexion with the group of nepheline rocks here considered, and it may be suspected that the relation is not purely accidental.

metres, the highest of the denudation-ridges in the part here considered rising to a little over 700 metres. The geological age of this plateau has only in part been determined. The lower beds are soft shales and sandstone with flaggy siliceous limestones, which last are remarkably persistent, having been found across nearly the whole width of the Provinces of São Paulo and Parana, a distance of about 300 miles. The limestone has afforded fossil reptiles, wood, and a few unsatisfactory shells, all of which indicate Upper Palæozoic (Carboniferous or Permian) age. The most satisfactory fossils are the silicified woods, which include *Lepidodendroids*, conifers of the *Dadoxylon*-type (conifers with a single row of pores also occur), and ferns of the type of *Psaronius*. Above the limestone come heavy beds of sandstone with intercalations of a melaphyre-like rock, often porphyritic and amygdaloidal, which has not afforded fossils, but is presumably Permian or Triassic. The railway for some distance out from Campinas is at times on the sedimentary series, at times among gneiss hills of the mountainous zone; but after crossing the river Mogyguassu the latter disappear and the main line to Casa Branca follows a flat-topped sedimentary ridge between that river and the Rio Pardo, leaving the Caldas group of mountains, which lies between the head-waters of these two rivers, to the eastward. The Caldas branch runs over the sedimentary series to within about 10 miles of the foot of the mountain, where it disappears, giving way to the gneiss foot-hills. Sedimentary rocks, however, appear in a narrow belt along the foot of the mountain, and it is probable that the interruption above noted is due to the fact that the railway follows the bottom of a valley, and that on the heights on either side the sedimentary strata extend continuously to the mountain. At all events there are no reasons for supposing that the beds at the foot of the mountain belong to a different series from those further away, whose geological age is fixed by the occurrence near Casa Branca of limestones with characteristic fossils.

The railway ascends the mountain on one side of the valley of the Corrego (brook) do Quartel, rising in a distance of 18 kilometres from 820 metres at the Prata station to 1270 metres at the summit. The eruptive series begins to appear about 2 kilometres from the foot of the serra in a cutting near the Prata bridge, where a greenish spotted phonolite appears associated with gneiss. Then follow a few low cuttings of sandstone of no special interest. The ascent proper commences with the passage of a narrow gap between magnificent cliffs of sandstone rising about 50 metres above the road-bed. This gap is cut through a narrow ridge set like a wall across the end of the rather broad valley of the Quartel. The sandstone is a very hard fine-grained white rock, broken by joints into small angular fragments, and is very similar in appearance to some of the beds of quartzite (itacolumite) of the metamorphic series, and quite unlike the ordinary sandstones of the sedimentary group above described. That its relations are with this group rather than with the older one is, however, proved by thin beds of soft clay-shales intercalated in it near the base along with a thin layer of

chert, this last being a very characteristic feature of the Carboniferous series of São Paulo. No fossils could be found, and its complete identity with the Carboniferous series could not be satisfactorily established, since it is possible, though not very probable, that two distinct formations in this region may be characterized by cherty layers. If it is distinct I am very strongly of opinion that it will prove to be older rather than newer. The beds are inclined at an angle of 15° to the eastward (away from the mountain), strike N. 20° W. So high an inclination is unusual in the series to which this rock is referred, which, whenever it has been examined, is essentially horizontal or with only slight local inclination. As, however, the eruptive activity of this region continued after the sandstone was deposited, the disturbance may be regarded as local. Passing the gap the road bends round and follows the base of the ridge, cuttings in sandstone appearing for a distance of two or three kilometres. In some of these the rock is seen to pass into a tuffaceous conglomerate containing pebbles of quartzite, and pebbles and boulders of eruptive rocks. A peculiar feature of this conglomerate is the presence of abundant and often large masses of brown mica, which, from its occurrence in masses of considerable thickness and of almost perfect crystalline form, not in detached flakes, must have been formed in place after the coarser material of the rock was deposited.

In the cuttings both the sandstone and the conglomerate are considerably decomposed, and the contact is not perfectly clear. In one, sandstone is seen above, conglomerate below, with no apparent line of demarcation between them, although the passage from coarse conglomerate to fine-grained and homogeneous sandstone is an abrupt one. That an actual passage occurs seems to be confirmed by the fact that in the coarser parts of the conglomerate, and near the supposed contact, the cement is extremely quartzose, whereas further away and in the finer portions the eruptive elements predominate in the cement, and the same rock with its characteristic crystals of mica presents the aspect of an ordinary tuff. The predominant types among the boulders of the conglomerate are two rocks which were not found satisfactorily exposed *in situ*. One has the external aspect of a moderately coarse-grained diabase, which, under the microscope, shows remarkably fresh plagioclase as a predominant element, the other elements being altered beyond recognition by me, and in a manner which I have never seen in any diabase. From its behaviour with acids it appears to contain nepheline, in which case it is probably a teschenite. The other rock common in the boulders seems to me to be a somewhat altered phonolite, but, if so, it is much richer in iron than any undoubted phonolite that I have examined. Undoubted specimens of phonolite also appear in the conglomerate.

In one of the cuttings in sandstone a dyke of phonolite occurs, also a dyke of a rock too much decomposed for positive recognition, but which appears to be identical with the diabase-like rock of the boulders. In another cutting in conglomerate there is an inclined

dyke, about 9 metres wide, which is of extreme interest (fig. 2). Owing to decomposition, only detached fragments, still *in situ*, of perfectly sound rock could be obtained, those near the margins being typical phonolite, those near the centre foyaite equally typical. Another case of the peripheral development of phonolite as a phase of foyaite will be mentioned hereafter.

Fig. 2.—Section of Decomposed Dyke in cutting, Corrego do Quartel.

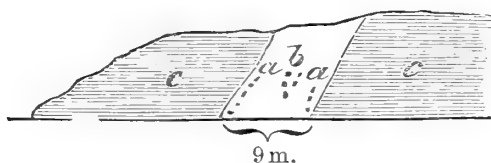

- a. Decomposition-nodules of phonolite in decomposed dyke.
- b. Decomposition-nodules of foyaite in decomposed dyke.
- c. Decomposed micaceous conglomerate.

Leaving the sandstone and conglomerate area at an elevation of about 900 metres, which is presumably about its highest level, the road, while following in general a nearly straight line for about 10 kilometres to the Cascata station, near the summit winds about for a considerable space marked off by lateral valleys, in which the road makes long and sharp bends to the eastward. The extreme points of these bends are marked by the Pinhalzinho culvert, the tunnel and viaduct, the intervening distances being $3\frac{1}{2}$ and 2 kilometres. In the U-shaped bends of Pinhalzinho and of the tunnel and viaduct, where the road crossing the lateral valleys enters most into the material of the mountain, nepheline-rocks alone are found, while along the projecting portion of the lower space a dark-coloured basic rock with prominent crystals of pyroxene is exposed in several considerable cuttings. This is in general totally decomposed, showing only rarely, in spots, stony nuclei of a mottled bluish and brownish colour and heavily charged with white zeolites; but in all cases the outlines of the pyroxene-crystals are sufficiently well preserved to serve for its ready identification. In one cutting only, between the tunnel and Pinhalzinho, is the rock perfectly preserved. Two types are here presented: one is a jet-black basalt, which, according to a note kindly furnished me by Prof. Rosenbusch, is a leucitite; the other is a bluish-black tuffaceous rock containing pebbles up to the size of the first of the leucitite, but as it also contains prominent crystals of pyroxene, the two rocks cannot be distinguished in the decomposed masses. The relations of these basic rocks to the nepheline-series is shown in two cuttings between the tunnel and the viaduct, represented in the annexed sketches (fig. 3). Both rocks are much decomposed, but in spots are sufficiently preserved to make their identification perfectly certain, while owing to the marked difference in colour of the decomposition-products the line of contact is remarkably sharp. I could not make out satisfactorily whether the leucite-rock was originally a basalt or a tuff. The appearance

is suggestive of denuded hills of leucite rock buried beneath a flow of phonolite. The former rock occurs in the little valley between the two cuttings, the relative position of which is very much as represented in the figure, so that it is probable that the two masses are connected underneath a capping of phonolite. The peculiar-shaped detached mass in the left-hand figure can hardly be a dyke, and is

Fig. 3.—*Sections on Railway near Pinhalzinho.*

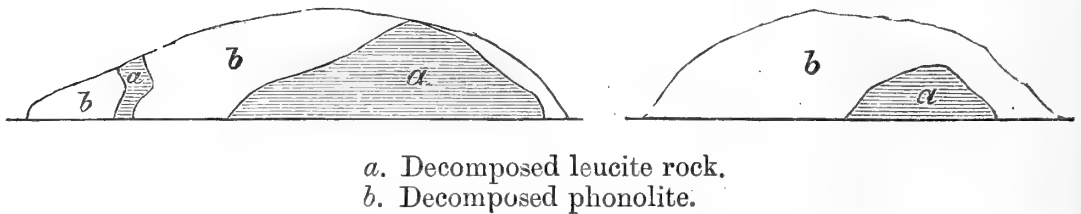

perhaps a fallen boulder enveloped in the phonolite. It is 4 miles wide in the widest part and lies about 20 metres away from the main mass. In the cuttings in leucite rock below Pinhalzinho several dykes, from 2 to 4 metres wide, occur, some of which are evidently of decomposed phonolite, while one, which is better preserved, although altered to some extent, is either a trachytic rock or a more felspathic phonolite than any elsewhere observed.

In the bends of the tunnel and of Pinhalzinho there are considerable cuttings in dark blue phonolite and in a peculiar red rock intimately associated with it. The latter is best preserved at the tunnel; but even there, although the rock is apparently perfectly sound, its brisk effervescence with acid shows that a part of its original constituents have been transformed into carbonates. Under the microscope, I could make nothing out of it beyond the occurrence of minute dark microlites in a very finely granular ground-mass. In places, dark red glassy crystals of hexagonal outline and irregular whitish spots occur sparingly; both appear to be of secondary origin. Generally the rock appears very homogeneous, but in places thin undulating streaks of lighter and darker red, giving an appearance of fluxion-structure, are seen. In other places there are patches and streaks of bluish and greenish phonolite, which appear to shade off into the red rock without well-defined outlines, such as would be expected if they were foreign inclusions. Patches of included pebbles and boulders with well-defined rounded outlines are also seen; and two or three large cuttings near Pinhalzinho are exclusively through a coarse boulder-conglomerate, which is, however, so much decomposed that only on the closest scrutiny can it be distinguished from the ordinary red rock. This conglomerate is well exposed in a ridge just above the tunnel, intercalated between two closely adjacent ridges of the red rock, and passed by a cutting about 80 metres long and 15 metres high, in which hundreds of broken boulders with perfectly fresh fracture are seen. They are all well rounded and of all sizes up to a cubic

metre, mingled together in the greatest confusion, and loosely cemented by a paste of pebbles and minute rounded grains of the same nature as the boulders. With the exception of a few masses which are fragments of a preexisting and more firmly compacted conglomerate of the same aspect as that of which they now form a part, all the boulders and pebbles seen are of the same character and, to my eye at least, undistinguishable either macroscopically or microscopically (except by a slight difference in colour, a light shade of red or a leaden colour being predominant) from the red rock of the adjacent cuttings. At one point a small mass of the red rock, decomposed, but evidently *in situ*, rests upon the conglomerate, which is also cut by a small dyke which, in its decomposed state, also resembles the red rock. A relation is thus established between this large and almost detached mass of conglomerate and the smaller patches, which are clearly included in the red rock, and the latter is thus seen to pass on the one hand into a fragmental rock, and on the other into a compact phonolite*.

On the same spur, between the tunnel and Pinhalzinho, occurs the largest exposure yet known in the region of foyaite, which evidently forms a considerable portion of the mass of the spur, and appears in connexion with the red rock throughout a distance of about 2 kilometres. The rock is in general of rather coarse grain, but of even texture, and weathers into large rounded boulders, which, if the massive rock was not seen in the cuttings, might be taken for erratics. In one place, at the side of a small ravine, the texture is porphyritic, with large and small polygonal patches of coarse-grained whitish rock and large and perfect felspar-crystals scattered through a bluish finely granular ground-mass, in which, however, the granitic texture is still apparent. At the tunnel the relations of the foyaite to the red rock are very well exposed. High up on the side of the peak above the tunnel a considerable mass of foyaite is seen close alongside of a considerable exposure of the red rock. The tunnel is excavated in a large irregular dyke-like mass of foyaite that cuts the red rock, and is most probably continuous with that of the top of the peak some 300 metres above it. This mass of foyaite is separated by an intervening mass of red rock from another about 100 metres further up the ravine, in which a quarry has been opened. The annexed sketches (fig. 4) of the two openings of the tunnel and of parts of its sides near the upper end show the relations of the two rocks. At the upper end, the lower part of the arch is of the red rock, rising highest on the left or upper hill-side; the upper part is of foyaite. A road cut on the right side, on a level with the floor of the tunnel, shows the foyaite cutting out the small patch of red rock of the right-hand side of the mouth, but giving way to it again a little further round the hill. This appearance can only be explained by regarding the foyaite as an irregular dyke-like mass, some 10 metres or more thick, cutting

* Judging from the reference in Rosenbusch's 'Mikroskopische Physiographie,' vol. ii. p. 299, a comparison might be made between this rock and that from Teneriffe denominated eutaxite by Fritsch and Reiss.

the red rock at a low angle. The tunnel, which describes a strong curve, soon enters wholly into the foyaite, which appears in the floor, roof, and sides: but a few metres beyond, the red rock appears again irregularly, still rising highest on the left side when the exposure is continuous (3), while in front it is divided into three distinct masses, the foyaite sinking between to below the floor of the tunnel (4). The road-bed again rises above the level of the lower

Fig. 4.—Sections across and on the sides of the tunnel near Pinhalzinho.

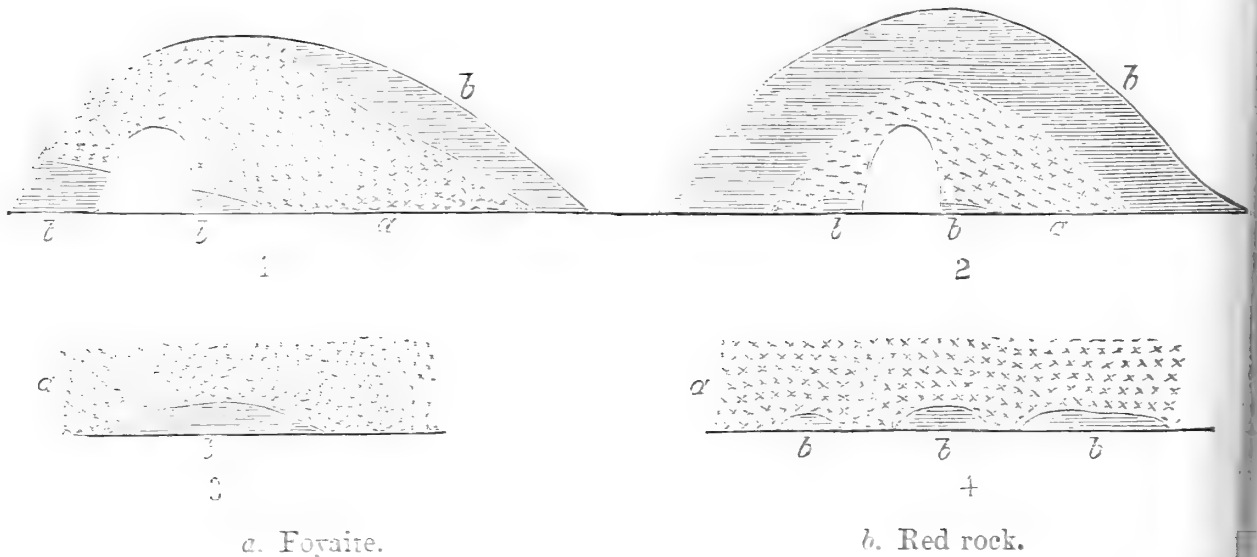

1. Upper mouth of tunnel.
2. Lower mouth of tunnel.
3. Left side of tunnel near upper end.
4. Right side of tunnel near upper end.

contact of the foyaite and the red rock, and continues in the former to the lower opening, where the latter again appears in very small patches on each side, which only rise very slightly above the floors. The foyaite forms quite a regular arch over the lower mouth of the tunnel (2); this comes out at the upper surface of the mass, which is covered completely by the red rock. The latter is here so broken into small fragments as to resemble an immense heap of chestnuts, and a land-slide of this incoherent material had, at the time of my visit, revealed a considerable surface of the foyaite on the slope over the mouth of the tunnel. This contact-surface was irregularly undulated, and inclined at an angle of 15° – 20° . The rock-openings and a part of the interior contacts have been concealed by masonry, but a portion of the latter are still exposed.

Both rocks near the contact are generally decomposed, and the red rock is everywhere too much so to reveal any modifications that it may have suffered. In places, however, the foyaite shows an interesting contact-phenomenon. At about a metre away the rock becomes finer-grained, and passes rapidly into foyaite porphyry and finally into true phonolite, the phonolitic facies extending for 10–15

centimetres from the immediate contact. Unfortunately I was unable to ascertain whether or not the same phenomenon is presented along the upper contact, as the places where it had been exposed were either decomposed or covered up by slides of the overlying red rock.

Above the tunnel, for a distance of 5 or 6 kilometres, the cuttings (with the exception of those in the red rock and leucite-rock already mentioned, and situated close to the tunnel) are mainly in phonolite, generally much decomposed, and of no special interest. In one a dyke of phonolite is seen, cutting a mass of decomposed foyaite, showing that if a part of the phonolite (as in the case of that enclosed in the red rock and the conglomerate near the foot of the mountain) is older, or (as in the case of the peripheral portions of the mass at the tunnel, of the dyke in conglomerate above mentioned and of the rock described below) contemporaneous with the foyaite, a part also is newer. A cutting about 2 kilometres below the Cascata station shows inclusions of foyaite in bluish phonolite, some of which are of considerable size. These present sharply defined outlines, and are either circular or show a tendency to mimic polygonal crystalline forms. The next cutting above, which is through a broad low ridge of foyaite, exhibits exactly the reverse inclusions, that is to say, of phonolite in foyaite.

This rock, which is apparently identical with that of two quarries off from the line of railway near the Cascata station, and almost in a straight line with the cutting, the furthest being at least a mile away, presents several interesting characteristics. The rock in the main resembles quite closely that of the tunnel, but contains a glassy honey-yellow ingredient, which has not been noticed elsewhere. It is also marked by indistinct circular spots slightly darker in colour than the generality of the rock, as if drops of oil had been sprinkled over it. In places also the nepheline, which is generally bluish, takes on a rather brilliant red colour, and appears to present more distinctly marked crystalline forms. Small points and thin irregular lines and, in one case, a pear-shaped inclusion two inches long, of an amethystine colour also appear. The most interesting of its peculiarities, however, are the inclusions. Some of these are irregular masses more coarsely crystalline than the enclosing rock, which, owing to the predominance of large crystals of felspar, have something of the aspect of pegmatite. Others are pebble-like masses of finer-grained and darker foyaite, while others again, and these are the most common, are of phonolite. These are of all sizes up to that of a man's head, with sharply defined and generally angular outlines, though without the mimicry of crystalline form presented by the reverse inclusions of foyaite in phonolite. The smaller inclusions, often no larger than the end of the thumb, are perfectly homogeneous in appearance; but in some of the larger ones there is a more or less distinct mixture of granitic and felsitic material. Two of the largest inclusions seen are here represented (figs. 5 and 6).

Fig. 5.—Phonolite-inclusion in Foyaite, one sixth natural size.

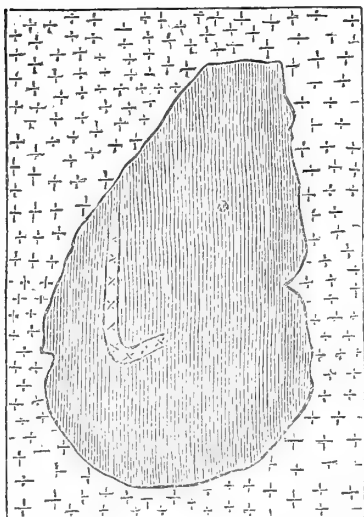
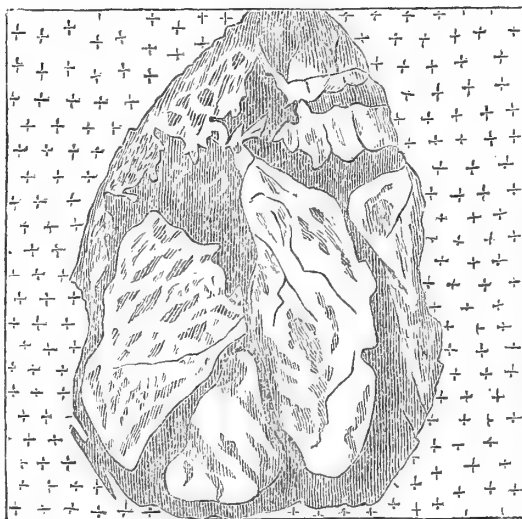

Fig. 6.—Crystalline inclusion in Foyaite, reduced about one half.



The larger one (fig. 5), which is 9 inches long and 4 inches wide, is a blue phonolite, with tolerably abundant crystalline inclusions in the left-hand portion, which become rarer towards the right. On the left side there is also a long, curved, ribbon-like inclusion of foyaite, which shades off at the lower end into the including rock through a group of scattered crystals, such as are common in phonolite. The other one (fig. 6), which is about 4 inches long, is represented above as it appears on an irregularly fractured surface. The dark-shaded portion is felsitic, and may, I think, be considered as phonolite, notwithstanding its abundant crystalline inclusions. It forms a distinct sheath, sharply defined against the enclosing foyaite, about the whole inclusion, and also about the three principal crystalline masses imbedded in it in the lower part of the mass. It appears, however, to shade into these, and into the smaller and less-defined inclusions of the upper part. These masses differ considerably in aspect from the enclosing foyaite, and are flecked with small dark patches apparently related to the felsitic mass. As the specimen has been placed in the hands of Prof. Rosenbusch, no further description of it will be attempted here, as, for my present purpose, it is sufficient to signalize the double nature of the inclusion, that is to say, of a rock of granitic texture in one of felsitic character, which is itself enclosed in a rock of granitic type. The appearance of this and other inclusions, coupled with the facts already stated, as to the occurrence of phonolite as a peripheral facies of foyaite, lead me to regard the inclusions, whether in the one or the other of the rocks, as parts of the same original magma. A petrographical examination will doubtless determine whether this view is correct or not.

From the cutting in foyaite, above mentioned, to the Cascata station the road winds for about a kilometre around a prominent spur, some 400 metres wide, of bluish-black and greenish tuff, which

in general appears quite homogeneous, but in many places shows layers and patches of pebbles up to the size of a hen's egg. The pebbles could not be certainly recognized, but the most abundant appear to be similar to the diabase-like rock of the conglomerate at the foot of the mountain, only finer-grained and somewhat altered, so that only lath-shaped feldspars could be made out with certainty. This tuff further resembles that associated with the conglomerate by the presence of rare and small flakes of brown mica. It is cut by small dykes of phonolite, and by dykes about 20 centimetres wide, too much decomposed for recognition, but which appear to be of a basic rock. One mass which I had noted in a field as a dyke, one metre wide, of a basic rock, proves on examination to be composed mainly of granular quartz and magnetite, and is probably not a dyke, though it certainly presents the appearance of one. The tuff is also traversed by horizontal vein-like masses, from one to two inches thick, of a highly felspathic rock of granitic or coarse porphyritic texture, and by vertical dykes, from 3 inches to 2 feet wide, of a rock that appears to be a more crystalline variety of that of the horizontal dykes or sheets. In the largest of these dykes, which is much decomposed, the feldspar crystals attain the diameter of an inch. In aspect this rock resembles the felspathic veins of granite and gneiss much more than it does the foyaitic rocks of the region in which it occurs. Under the microscope it differs markedly from any rock known to me; but I suspect that it will prove to be an augite-syenite, or perhaps a liparite. Whatever it may be, it, with the phonolite dykes, serves to connect the tuff with the crystalline rocks of the region.

Close by the Cascata station there is a small cutting in decomposed quartzite intercalated between two cuttings in tuff. The rock is so decomposed and broken by joints that its position could not be satisfactorily determined, but it appears to dip to the eastward at an angle of about 20° . It is cut by small dykes of phonolite and by very thin irregular veins of pegmatite, showing large quartz-grains and kaolin in the form of feldspar, which I take to be different from the felspathic dykes and layers in the adjacent mass of tuff. In appearance the rock is not very unlike the sandstone at the foot of the mountain; but its occurrence at a much higher level, the presence of granitic masses apparently distinct from the eruptive group that characterizes the region, and, above all, the occurrence in similar conditions at another point, to be described below, of undoubted itacolumite, lead me to refer this exposure to a series much older than that represented at the foot of the mountain.

At Cascata the road leaves the wooded slope of the valley of the Quartel and enters the Campo region of the mountainous plateau of Caldas. This plateau extends northwards some 15 or 20 miles to the Rio Pardo, which, where I crossed it, flows at an elevation of 875 metres. The mean elevation of the plateau is about 1200 metres, the undulating surface presenting differences of level of from 100 to 200 metres. It is bounded on the west and north by an approximately semicircular arc of ridges rising abruptly from 200 to 400

metres above the general level. Similar but shorter detached ridges (the Serra do Caracol and Serra de Caldas) to the southward and eastward appear to complete an approximately circular or elliptical enclosure (fig. 7). This circular arrangement of the higher ridges is peculiar, and, taken in connexion with the character of the predominant rocks of the plateau and of the bounding ridges, as far as examined, is probably not without significance.

Fig. 7.—Sketch Map of the Caldas region.

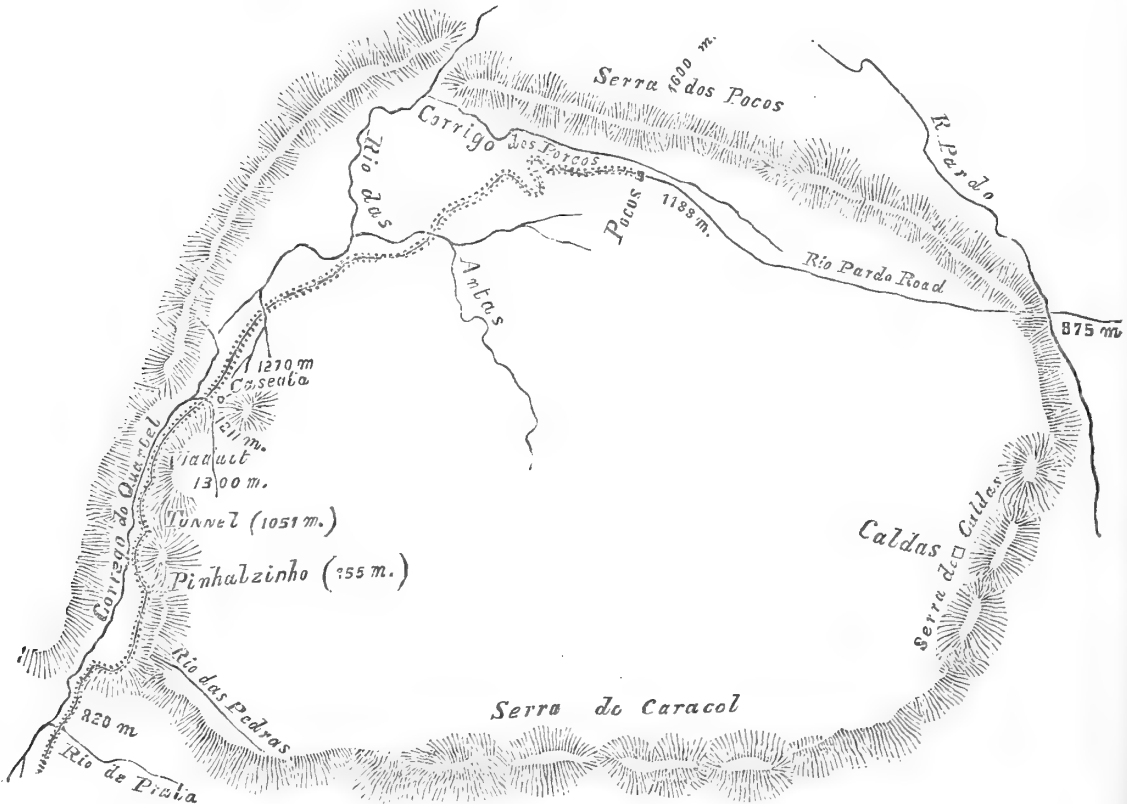

In the 18 kilometres of railway from Cascata to the village of Poços the cuttings are mainly in decomposed rock, which is, however, sufficiently preserved in patches to show its original character, either in loose masses or in the traces of structure still visible in the clay resulting from decomposition. The predominant rock is phonolite. Foyaite appears rarely in a few cuttings, always totally decomposed. No evidence of the existence of other rocks was met with, and the absence of dykes is noticeable. About 4 kilometres from Poços two cuttings in decomposed phonolite show an abundance of decomposed analcime, some of the crystals measuring 3 inches in diameter. Near Cascata two quarries, already referred to, have been opened to the right of the road in hills of foyaite with abundant inclusions. Close to one of these there is a hill of coarsely porphyritic phonolite unlike any variety seen on the railway. The crystalline inclusions are of all sizes up to an inch in diameter, with ill-defined limits and generally stained red, the red colour extending at times to the ground-mass, which is normally bluish, the inclusions being white. This reddening of the rock without visible signs of decay has extended to nearly the whole quarry, so that masses free from

it are somewhat difficult to find. It is seen, however, to be most pronounced near the surface and in the neighbourhood of fissures, and is undoubtedly due to weathering or to infiltrating waters. This phonolite differs further from all other varieties seen in the region, except that of the Prata bridge, in being fit for a building-stone on account of its freedom from the fine joints and splintery fractures that generally characterize the Caldas phonolites. About the village of Poços the phonolite is generally distinctly granular, and might perhaps be regarded as a fine-grained foyaite. The hot sulphur springs (temp. 45° C.) that give name and importance to the place issue from the midst of the phonolite. The hill close to the village (1600 metres high, the highest of the semicircular ridge) was examined for a distance of over a mile, and found to consist exclusively of phonolite. This rock also characterizes the road from Poços to the Rio-Pardo margin of the plateau, occurring also with foyaite along the descent, but, apparently, not extending beyond the river.

The Rio das Antas, the principal stream of the plateau, just before it breaks through the ridge to descend to the Rio Pardo, traverses for several hundred metres a considerable patch of quartzite. In places this shows the flaggy structure and other characteristics that identify it with the itacolumites so abundant in the province of Minas. The geological age of the series to which it belongs has not been determined for Brazil, but it is certainly very old. Rocks similar to it and to its associates are called Huronian by many North-American geologists. The strike is N. 20° W. *; dip 20° S.W. A small exposure of phonolite occurs close to the quartzite, and two quarries in foyaite have been opened in the immediate vicinity, but the relations of these rocks to the quartzite could not be seen. A little above a cascade formed by the quartzite there is another, in which the rock, at first sight, appears to be similar; but on closer inspection it is seen to be a greenish tuff enclosing fragments of eruptive rocks. This continues for a considerable distance up stream, then isolated masses of quartzite begin to appear associated with it, though in no case could an actual contact be discovered, nor could pebbles of quartzite be detected in the tuff, though grains of quartz and fragments of gneiss are not uncommon. Apparently, however, the tuff forms a layer on an irregular surface of quartzite, points of which occasionally appear through it. The tuff is traversed by joints running N. 70° E., and dipping 70° N., which in places produce a sort of flaggy structure.

The Rio Pardo appears to form the northern limit of this eruptive group as the Rio de Prata forms the southern. Going northward from the Rio Pardo only gneiss, mica-schist, and granite were met with between that river and the Rio Grande. North of the latter

* It may here be remarked that I found a north-westerly strike predominant between Caldas and the Serra do Canastra, as well as in that range, whereas in Eastern Minas and along the Serra do Espinhaço the strike is almost universally north-westerly. It is for this reason that I have ventured to suggest (by the dotted line of the map, fig. 1) the derivation of the Serra do Canastra as a branch of the Mantiqueira range.

the quartzite (itacolumite) and metamorphic-schist series (represented in the Caldas region by the quartzite of the Rio das Antas and Cascata) appears in the well-defined mountain-range known as the Serra do Canastra, which forms the western wall of the São Francisco basin and the watershed between that river and the upper Parana. The sandstones and bedded melaphyres of the upper part of the São Paulo plateau abut against the western side of this range, their eastern margin cutting across the rivers Pardo and Grande, some distance to the westward of the Caldas mountains. Gneiss is said to occur on the mountainous plateau near the city of Caldas, and fine and large crystals of zircon come from the same locality, leading to the suspicion that zircon-syenite or a zirconiferous variety of foyaite may occur in that vicinity. The limited time at my disposal did not permit me to follow up this interesting suggestion*.

Pending the detailed microscopic examination of the Caldas rocks which Prof. Rosenbusch has kindly undertaken, it does not seem desirable to attempt to go very far in drawing conclusions from the observations recorded in this interesting region. It is hoped, however, that this imperfect exposition may prove as convincing to the minds of others as the phenomena observed in the field were to my own mind on the following points:—

1st. The substantial identity as regards mode of occurrence and geological age of the Caldas phonolites and foyaites.

2nd. The connexion of the latter through the phonolites with a typical volcanic series containing both deep-seated and aerial types of deposits.

3rd. The equal, if not greater, antiquity of the leucite-rocks as compared with the nepheline-rocks, whether felsitic, as phonolite, or granitic, as foyaite.

4th. The probable Palæozoic age of the whole eruptive series.

The interruption in the section of the sedimentary series near the foot of the Caldas mountains renders the last conclusion less positive than could be desired. The conglomerate at the base of the sandstone at the foot of the mountain proves that the eruptions commenced before or during the deposition of the sandstone, while the dykes cutting the latter show that they continued after the deposition. It is certain that at the time when the present sedimentary plateau of São Paulo was occupied by a late Palæozoic or early Mesozoic sea, the Caldas mountains, with an elevation of at least 200 metres, rose either at the margin, or not more than 10 miles distant from the margin of that sea, and this, in accordance with the law of the relation of volcanoes to the coast-line, may be taken as an argument in favour of the great age of the eruptions, since no late Mesozoic or Tertiary marine deposits are known nearer than the present Atlantic coast between Rio de Janeiro and Bahia, or the Pampa region of the Paraguay basin. Freshwater Tertiary deposits are known about the city of São Paulo and between the Serras do

* Zircon has not been recognized in any of the Brazilian foyaites thus far examined. Sphene is a characteristic and abundant microscopic accessory in that of Cabo Frio, Tingua, and Itatiaia, but has not been observed in that of Caldas, which also differs in other respects from that of the other localities.

Mar and Mantiqueira in the valley of the Parahiba; but these are certainly newer than the eruptions of similar material of Itatiaia. Unfortunately the other localities mentioned in this paper afford no prospect of throwing light on the geological age of the nepheline-rocks, as there are no sedimentary beds in their vicinity intermediate between the gneiss and the recent deposits. They promise, however, to give important results on the relations of various types of eruptive rocks, and it is hoped that an opportunity will soon be afforded for examining and describing them more fully.

DISCUSSION.

The PRESIDENT said it was seldom that a paper containing such important facts was presented to the Society. It was reserved to Mr. Derby to have proved that plutonic rocks containing nepheline (foyaite) passed into volcanic masses which were true phonolites. This Mr. Derby had clearly established by observations in the field. He had also shown that leucite existed in rocks of palæozoic age, thus rendering untenable the last stronghold of those who insisted on making geological age a primary factor in petrographical classification. He alluded also to the value of the independent determinations of Prof. Rosenbusch.

Mr. BAUERMAN had been over portions of the ground with the Author, and was glad to add his testimony to the value of the paper. He spoke of the importance, in a geological sense, of these generalizations. It was remarkable how highly crystalline masses of rock pass over into a sort of phonolite. These were associated with palæozoic masses, which were pre-Permian or at least pre-Triassic. He alluded to the difficulty of investigating Fernando Noronha, and also to the difficulties attendant upon the investigation of rocks in Brazil, which were subject to such an enormous amount of local alteration.

Prof. BONNEY also expressed his sense of the value of the paper. He alluded to the comparative rarity of nepheline- and leucite-rocks, and to the confusion in the nomenclature. He was reminded of the nepheline-rocks near Montreal, where dolerite was broken through by nepheline-syenite, associated with tephrites and phonolites. Although there might be a doubt here, these rocks were most probably of Silurian age; but the evidence in Brazil was still clearer as to the palæozoic age, and he believed that, in the case of some other masses, the evidence had satisfied the Canadian geologists. He alluded also to the nepheline-rocks in the Katzen-Buckel, where there was a similar passage from coarse-grained to fine-grained.

Dr. HATCH said that in this case leucite was clearly shown to be of palæozoic age, and he regarded the paper as a step towards the better classification of this group of rocks.

Prof. SEELEY asked for evidence as to the identification of the leucite.

The PRESIDENT thought there was no possibility of mistake in this respect. As regards the rocks of the Katzen-Buckel, none were truly holocrystalline, and hence they could not be compared with foyaite or elæolite-syenite.

34. *On some OCCURRENCES of PIEDMONTITE-SCHIST in JAPAN.* By Prof. BUNDJIRO KOTÔ, Ph.D. (Read June 8, 1887.)

[Communicated by FRANK RUTLEY, Esq., F.G.S.]

As already stated in a former paper *, the occurrence of mangan-epidote or piedmontite is often associated with glaucophane-bearing rocks in the crystalline-schist system in Japan. The rock which contains piedmontite as an essential component is well characterized in outward appearance, being of a dark violet colour; hence it is locally named the 'murasaki' or violet rock, and it is most typically developed in the Island of Sikoku, especially in the neighbourhood of the city of Tokusima.

The first specimen that came under my notice was brought from Mount Otakisan, one mile to the south-west of the last-named city; and many localities have since been added to the list of places where it occurs, so that we are now able to trace out the geological horizon of the piedmontite-bearing rock everywhere within the crystalline-schist system of that island. The rock is, however, not exclusively confined to this region. It also has a wide distribution in the provinces of Musasi and Kozuké, on the main island, Honsiû.

The piedmontite is associated with fine quartz-grains; and by the parallel position of the former, the rock itself assumes a schistose structure, a vertical section presenting a regularly banded appearance resulting from the alternation of fine piedmontite layers with those of quartz.

The accessory components are muscovite (hydrous mica of Prof. Bonney †), greenish-yellow garnet, rutile, some feldspars (probably orthoclase), blood-red iron-glance, and also opaque crystals of the same mineral. This is the typical piedmontite-schist. In the glaucophane-bearing rocks ‡ manganepidote also makes its appearance, but it is subordinate in quantity to glaucophane, and its place is often supplied by common yellowish-green epidote. We shall, first of all, speak of the epidote in the piedmontite-schist.

(a) *Piedmontite*.—Crystals of piedmontite are usually much elongated, traversed by transverse irregular cracks and fissures, sometimes broken, and then the dismembered parts form chains, with faces striated in the direction of the axis of symmetry. Nearly all the crystals lie with the orthopinacoid ($\infty P^{\frac{1}{\infty}}$), parallel to the planes of schistosity of the rock.

Unlike the common rock-forming epidote, in which well-defined crystallographic forms are seldom to be seen, these crystals of piedmontite have usually well-developed faces of M (oP), T ($\infty P^{\frac{1}{\infty}}$), $i(\frac{1}{2}P^{\frac{1}{\infty}})$ $n(P)$, sometimes $r(P^{\frac{1}{\infty}})$ as in fig. 1.

The clinopinacoidal section ($\infty P^{\frac{1}{\infty}}$) is, as a rule, of an oblique

* Journal of Science College, Imperial University, vol. i. part 1, p. 85, Tôkyô.

† Min. Mag. vol. vii. no. 32, July 1886, p. 3.

‡ *Loc. cit.* p. 86.

rhomboidal outline, caused by the predominance of the traces of T and M as in the figure, and if the faces r or i be also developed the section will then be six-sided; but the latter case is less frequently seen. In common epidote the face r ($P\frac{1}{\infty}$) is said to be a predominating element, and, as a rule, it is more perfect than the face T ($\infty P\frac{1}{\infty}$). In these piedmontites the face r is very poorly developed, and it is usually not visible even in the clinopinacoidal section, the outlines

Fig. 1.

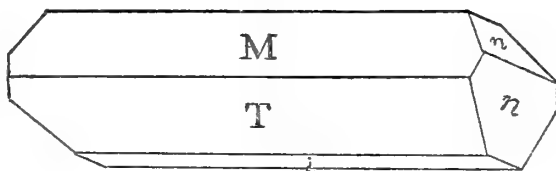

of which are never regular, owing to the fact that there are an infinite number of prominences and indentations, and they are sometimes even knee-shaped, just like twins of rutile. All these facts are due to the parallel growth and intergrowth of two or more individuals of different sizes; the striations commonly observed on the faces parallel to the ortho-axis arise mainly from these causes, and proportionally few of the striations can be attributed to the twinning.

Extinction takes place simultaneously in all the individuals that enter into the formation of the complex crystals, and this would not occur in the case of twins. Some of these remarkable forms are given in figs. 2, *a*, *b*, *c*.

Fig. 2.

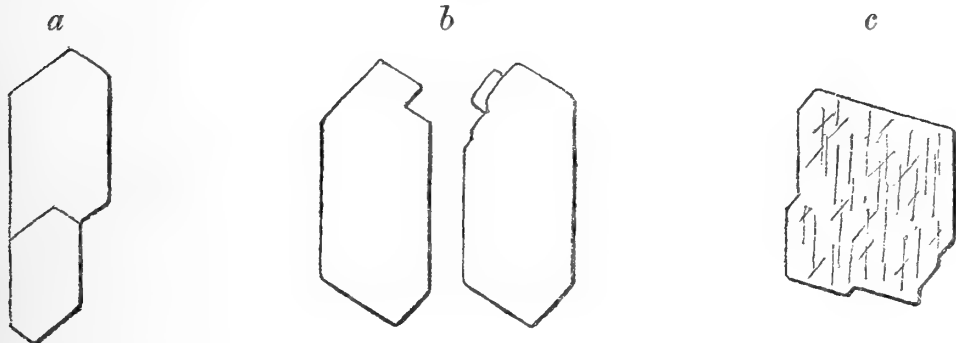

Twins are comparatively rare, and, if present, they are of a common type whose plane of twinning and composition is T ($\infty P\frac{1}{\infty}$), the extinction-direction of the one individual making an angle of 6° with that of another (fig. 3). The traces of cleavage upon M, in both individuals, meet at an angle of about 130° , just as in the case of common epidote described by F. Becke* and H. Reusch†. The

* Tschermak, *Min. u. petr. Mitth.* 1879, p. 837.

† *Neues Jahrb. für Min. etc.* ii. 1883, p. 87.

crystal individuals of twins differ considerably in their size, and the one bears a parasitic relation to the individual to which it is attached.

The colour and the behaviour of pleochroism in twins are exactly

Fig. 3.

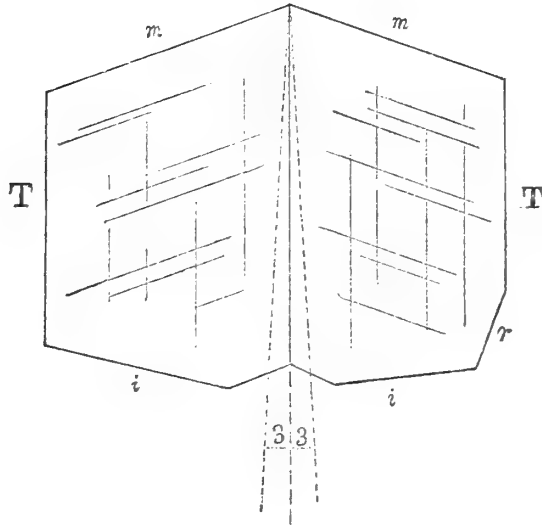

similar in most cases, so that the existence of twinning can only be recognized by a slight difference in the shade of colour of both crystals under crossed nicols, and also in the direction of the traces of cleavage upon M.

Cleavages upon the base (oP), and orthopinacoid ($\infty P \infty$) are sometimes observed; but in minute crystals they are, as a rule, less distinctly developed than in the larger individuals; for in the majority of cases the smaller ones are perfectly free from such traces of cleavage.

The angle of oblique extinction:— $c : A = 3^\circ$. The axial colours: A=deep reddish-violet; C=brownish red; B=light violet. The degree of absorption: $A > C > B$; while in common epidote it may be expressed in the following scheme*, $C > B > A$. Therefore the clinopinacoidal sections of this mineral show the most intense colours, while those parallel to the ortho-axis display a lighter tint. When a slide is prepared in the direction of the planes of schistosity in the rock, we usually see sections approximately parallel to the b -axis; but we also perceive a marked difference in the colours of various sections suggestive of entirely different minerals; the one is a deep violet, the other a brownish yellow. As there are great differences in the axial colours already stated, it may be naturally expected that a section parallel to the basal pinacoid M is of a brownish yellow; for we see the combination of the axial colours of C and B; that which is taken nearly parallel to the orthopinacoid T is of a deep violet (a combination of A and B). The clinopinacoidal section shows the deepest shade of colour, the face-colour being a combination of C and A.

* Rosenbusch, 'Mikroskopische Physiographie,' i. p. 497, 2te Auflage.

The extinction-direction is, of course, parallel and at right angles to the longer sides of sections in the zone of M and T, and the intensity of the colours also depends upon the section in this zone. The polarization-colours are magnificent, ranging from an intense violet to an indigo-blue tinge, and this becomes more pronounced if we insert a quartz-plate in the tube of the microscope.

The piedmontite is generally pure; neither liquid-enclosures, gas-enclosures, nor microlithic interpositions being found in large quantities. Minute crystals represent the ideal purity of the mineral.

This mineral has been isolated from other constituents of the schist from Ôtakisan, Awa province, by means of Thoulet's solution. The result of the chemical analysis, kindly undertaken by Mr. J. Takayama, of the Geological Survey of Japan, is as follows:—

SiO ₂	36·16
Al ₂ O ₃	22·52
Fe ₂ O ₃	9·33
Mn ₂ O ₃	6·43
CaO.....	22·05
MgO.....	0·40
K ₂ O.....	trace
Na ₂ O.....	0·44
H ₂ O.....	3·20

100·53

H : Ca :: 1 : 2·2 Ca : R : Si :: 1·25 : 1 : 1·92

(b) *Comparison with other Occurrences.*—On comparing the result stated above with analyses of Swedish and Alpine epidotes* our mineral shows in some particulars a marked difference in the percentage-composition from both of them; there is nevertheless a general resemblance in all, and the Japanese epidote supplies a hitherto missing link between that of Jacobsberg, in Sweden, and that of St. Marcel, in Piedmont. Mr. Takayama states that he is as yet unable to decide whether the manganese in the Japanese epidote exists as sesquioxide or as monoxide, or as both. Igelström suggests that the Swedish mineral contains manganese as the monoxide, while others are of opinion that in the Alpine epidote the manganese exists only in the condition of sesquioxide. Some mineralogists therefore hesitate whether they should be regarded as the same mineral variety†. The writer before expressing himself decisively on this point awaits the results of a more complete examination.

Being of a very beautiful rose-red colour, highly pleochroic and acicular in habit, piedmontite is frequently confounded with tourmaline, and as such it was at first regarded by us. Dr. E. Naumann‡

* Rammelsberg, 'Mineralchemie,' 2te Auflage, p. 595.

† Naumann; Zirkel, 'Elemente der Mineralogie,' 12te Auflage, p. 577.

‡ 'Ueber den Bau und die Entstehung der japanischen Inseln,' Berlin 1885, p. 10.

notes that there are two interesting rocks in the crystalline-schist system of Japan, one of which is "ein echter durch charakteristische rothe Färbung kenntlicher *Turmalinschiefer*, der unter dem Mikroskop schöngefärbte starke dichroitische langgestreckte Krystalle zeigt." The original specimens from which E. Naumann penned the above-quoted statement were kindly placed at my disposal by the Geological Survey of Japan. On examining the various slides the writer was firmly convinced that here we have to do with true *pedmontite*, and not a tourmaline; and the analysis given above confirms the writer's view.

(c) *Geographical Distribution of Piedmontite*.—The mineral piedmontite is not of common occurrence. In treatises on mineralogy we find only two typical localities up to the present: the one is St. Marcel, near Aosta, in Piedmont, Italy, where it occurs, as a rare mineral, together with other manganese ores; the other is Jacobsberg, in Wermland, Sweden, where it is found localized within a limestone. In both cases, as it seems to me, piedmontite occurs as a rare mineral, and it is by no means abundant enough to form an independent rock.

Its extensive occurrence in Japan is somewhat remarkable, and is probably unequalled in other parts of the world; the manganepidote and quartz constitute the piedmontite-schists, and it is also an accessory component in glaucophane-schist*. Geologically speaking, its occurrence is confined to the same horizon as the glaucophane, *i. e.* the lower part of the chlorite-schist series of the Archæan complex. This unique piedmontite-bearing rock is of unexpectedly wide distribution, and constitutes, indeed, an essential member in the Archæan system of Japan. The subjoined are some out of many of the typical Japanese localities of manganepidote:—

Sikoku Island.

1. Ôtakisan, near the city of Tokusima, Awa province.
2. Bessi Copper-mine, in Uma Gôri, Sanuki province.
3. Chihara Copper-mine in Siufu district, Kitanada in Kami-Ukima district, Uchinoko and Kaya in Kita district, Iyo province.

Main Island.

4. Minano, Simo-Tano and Yorî, Chichibu district; Ogawa, in Hiki district, Musasi province.
5. Umenokidaira and Sambagawa, Kanra district, Kôzuke province.
6. Misaka, in Iwamae district, Iwaki province, &c.

(d) *A peculiar Epidote*.—There is still another variety which may be conveniently described on the present occasion. In speaking of the glaucophane-schist in his other paper†, the writer has already given a brief notice of the presence of a remarkable piedmontite.

* Journal of Science College, Imperial University, Tôkyô, vol. i. part 1. B. Kotô, 'A Note on Glaucophane,' pp. 85 *et seq.*

† *Loc. cit.* p. 85.

In this schist we find a peculiar epidote in the form of long irregular plates ($\frac{1}{2}$ –1 centim.), having a slight yellowish-green colour, and being irregularly traversed by transverse cracks and longitudinal striae. The morphological habitus differs from that of an ordinary epidote in its more flattened tabular condition. It possesses sometimes a faint rosy tint, its pleochroism is weak, but distinct, being more intense when the short diagonal of the lower nicol is at right angles to the longer sides of the epidote. In other instances the red pigment is localized in the centre (fig. 4), so as to form a distinct zone;

Fig. 4.

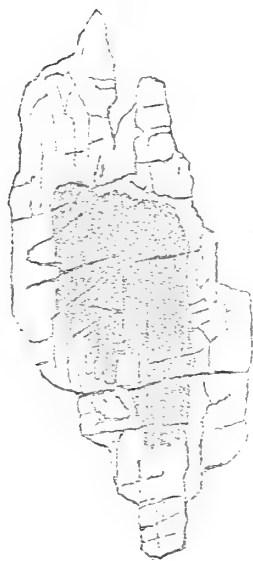

but the reversed case, *i. e.* a red margin with the yellow centre, has, within the writer's knowledge, never yet been observed.

The rosy pigment which characterizes this epidote is certainly due to the presence of a manganese oxide, and the mineral forms an intermediate link between common epidote and piedmontite. One point in connexion with this epidote should not pass unnoticed, namely the abundant enclosures of aggregates of opaque iron-glance, and blood-red hexagonal scales of the same mineral, since the typical piedmontite is entirely free from enclosures of such a kind. This indicates the fact that the latter (piedmontite) has crystallized out before the yellowish-green epidote.

(e) *Garnet*.—In the glaucophane-schist from Ôtakisan, in the Island of Sikoku, we find a large number of rhombic dodecahedra (size of a pea) of a greenish-yellow garnet. A slide cut from one of these garnets shows, under the microscope, that it is made up of different minerals as indicated in figure 5. This crystal is, indeed, a small mineral cabinet of all the constituents of the rock in which it occurs, except glaucophane. The violet piedmontite needles, clumps of dark iron-glance, hexagonal scales of iron-glance, the knee-shaped twins of rutile-needles which contain in their substance also a large number of already twinned crystals upon $P\infty$, and, lastly, highly

vitreous grains of quartz, are all thrown together within the garnet crystal, these enclosures assuming a more or less curved course.

The colour of the garnet itself is deep yellow, and the crystals show anomalous optical properties, being anisotropic. This is

Fig. 5.

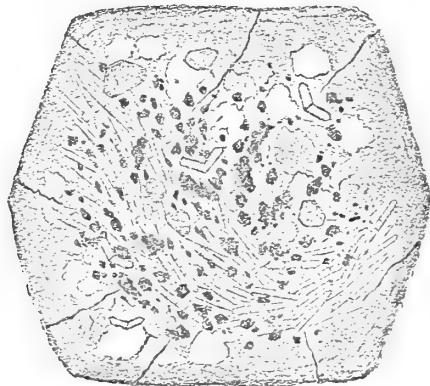

caused probably by the strain from the *interposition of other minerals* contained in it. Prof. Bonney* has also found garnet in certain glaucophane-bearing rocks near Berrioz, Val d'Aoste, in the Alps. Here the garnet sometimes contains glaucophane and dark dust(?), which he suggests may be possibly due in certain cases to subsequent infiltrations. The garnet here described is entirely free from enclosures of glaucophane, although the rock itself is a glaucophane-schist; and the above-mentioned interpositions, *i. e.* piedmontite, &c., seem to have been developed prior to, or contemporaneously with, the formation of the garnet.

DISCUSSION.

The PRESIDENT remarked that, in the slides, where the glaucophane was best developed, there the *piedmontite* was most rare, and that where the *piedmontite* was abundant but little glaucophane was to be seen. He alluded to the striking pleochroism of the *piedmontite*, and to the interesting fact of its having been now recognized for the first time as a rock-constituent.

Mr. MIERS, whilst claiming but little special knowledge of the minerals described, expressed his satisfaction with the paper.

Mr. HUDLESTON said that the President's remark precisely confirmed Mr. Kotô's statement to the effect that the *piedmontite* exists only as an accessory mineral in the glaucophane-rock, whilst it is one of the principal constituents in the *piedmontite-schist*, which contains hardly any glaucophane.

* "On a Glaucophane-eclogite from the Val d'Aoste," *Min. Mag.* vol. vii. no. 32, p. 2 (1886).

35. *On the Rocks of the MALVERN HILLS.* By FRANK RUTLEY, Esq., F.G.S., Lecturer on Mineralogy in the Royal School of Mines. (Read December 1, 1886, and April 6, 1887.)

[PLATES XIX.—XXI.]

PART I.

THE rocks of the Malvern Hills have already been the subject of much discussion, and some of our most eminent geologists have devoted a large amount of time and trouble to the unravelling of their history.

One of the most important papers, however, upon this subject was written by Dr. Harvey B. Holl*, over twenty years ago; and with this paper and a few maps I have spent several weeks in examining the range.

The general result of this examination may be of interest, inasmuch as it enables me to confirm to a great extent the statements made by Dr. Holl, whose careful observations and sound inferences cannot fail to impress those who endeavour to follow up his work.

One of the main points which Dr. Holl wished to demonstrate was, "that the rocks which had hitherto been treated of as syenite, and supposed to form the axis of the hills, were in reality of metamorphic origin, and belonged to the Pre-Cambrian, Azoic, or Laurentian Age." I think that, at the present day, many geologists will be found who are ready to accept this conclusion, in spite of the protest of the late Sir Roderick Murchison †.

Dr. Holl, in his paper, discusses first the structure and origin of the crystalline rocks of the Malvern Hills, he next treats of the adjacent Palæozoic strata, and finally endeavours to show the chronological relationship of the several events in their geological history.

Without attempting to follow out such an extensive programme, I have restricted my work to the old ridge of gneissic syenite, granite, &c. which constitutes the central or axial, and, indeed, the main portion of the range; and although I have failed to see many things, I have nevertheless verified much that Dr. Holl, the late Professor Phillips ‡, the Rev. W. S. Symonds §, and other observers have recorded.

At the outset, Dr. Holl describes the small hill known as Keys End or Chase End as consisting, at its southern extremity, of thinly bedded gneissic rocks dipping east, the gneiss being sometimes micaceous, at others hornblendic. This hill is the extreme

* "On the Geological Structure of the Malvern Hills and Adjacent Districts," *Quart. Journ. Geol. Soc.* vol. xxi. pp. 72-102.

† 'Siluria,' 4th edition, 1867, p. 14.

‡ 'Memoirs of the Geological Survey,' vol. ii. part 1.

§ 'Old Stones, a series of Geological Notes on the Rocks in the Neighbourhood of Malvern,' new edition, 1884.

southern member of the Malvern range, and after a more detailed description of it Dr. Holl carries the reader gradually northward.

Without following his description further at present, I will at once venture to expound the view to which my own examination of the range, coupled with a careful perusal of Dr. Holl's paper, has led me—a view which begins at the other end of the chain, and which, if true, may result in a better understanding of its structure.

In the first place, the beds of crystalline rocks, mostly of a gneissic character, which form the axis of the Malvern range have, I believe, been disposed in a synclinal flexure, which stretched from the north of the range as far as the middle of the ridge which forms Swinyard's Hill, where there is, I think, evidence to show that they experience a sharp anticlinal flexure and are then faulted downwards, to reappear no more in this country. The synclinal fold just mentioned, which is over five miles and a half in length, is probably more or less irregular through subordinate crumpling of the beds, and, in common with the rest of the range, is traversed obliquely by a number of approximately N.W. and S.E. or N.E. and S.W. faults, as already indicated by Dr. Holl.

Inferences regarding the upthrow or downthrow of the masses lying between these faults may, perhaps, be most safely arrived at from the corresponding displacements of the Silurian strata which occur on the western flank of the range, and although from a little north of Malvern Wells to the extreme north of the chain there appear to be successive downthrows to the north, yet south of Malvern Wells the throws vary.

From lithological evidence generally, it seems that the rocks forming the northern portion of Swinyard's Hill are a repetition of those which constitute the Worcestershire Beacon, and the assumed relationship of the beds is indicated in the diagrammatic section appended to this paper (facing p. 488) *.

We may infer that probably, but not necessarily, the oldest and once most deeply-seated beds of gneiss would be those which would have undergone the greatest alteration, that traces of bedding in them would be rare or very obscure and irregular, and that in crystalline structure they would approximate more closely to plutonic rocks than the higher beds of the series. In other words, we should expect to find the older beds occurring in the condition of coarsely crystalline gneiss, or even of crystalline rocks devoid of foliation, and the younger of finer texture and approximating to schists.

In the Malvern range we find the most coarsely crystalline rocks in the northern, and the fine-grained rocks and schists mostly in the southern hills. Hence it may, I think, be inferred that the rocks

* On referring to Phillips's Memoir, the following statement concerning what he termed "mottled syenite" will be found:—"As already observed, it is in the northern parts of the Malvern range, and especially north of the Worcestershire Beacon, that this beautiful rock appears most abundantly. It is, however, not entirely absent from any of the hills, at least in small masses. On the crest of Swinyard's Hill it may be found amidst the great variety of compounds which that narrow and interesting ridge presents." (Mem. Geol. Surv. vol. ii. pt. 1, p. 41.)

constituting the northern parts of the chain are older than those which occur in the southern end. The rocks of the North Hill and the Worcestershire Beacon are, as a rule, coarsely crystalline, and, I believe, older than those of the Raggedstone and its vicinity, which are for the most part of a schistose character. Owing to frequent faulting and subsequent denudation, the regular chronological sequence along the range is more or less disturbed, and in this manner we meet with very coarsely crystalline rocks in the northern part of Swinyard's Hill, only two or three miles from the southern extremity of the chain, which appear closely to resemble some of the very old rocks in the northern parts of the range.

The flanking beds of Palæozoic strata, which abut against the western side of the chain throughout its entire length, occur only on the eastern sides of the southern hills; and it does not seem unreasonable to suppose that their partial preservation on this side is due to the downthrow towards the south of the southern portions of the old ridge, although it must be admitted that there are some objections to this view.

Most of the faults which cross the axis, generally in N.W. and S.E., and N.E. and S.W. directions, have been indicated by Dr. Holl, who has traced them by means of breccias, or inferred their existence from marked discrepancies in the strike of the beds. An examination of the ground shows how carefully he has done this; but I have ventured here and there to extend some of these lines of fault from the Silurian area across the gneissic rocks, on the strength of somewhat meagre evidence not recorded in his paper.

As already mentioned, one of the most striking lithological features of this range consists in the generally coarsely crystalline character of the rocks forming the North Hill, the Sugarloaf, the Worcestershire Beacon, the Herefordshire Beacon, and the northern part of Swinyard's Hill. These constitute two well-marked masses when regarded lithologically—the first extending from the northern end of the chain to the Wych, while the second reaches from the northern foot of the Herefordshire Beacon to the fault which crosses Swinyard's Hill.

These two masses consist, for the most part, of coarsely crystalline gneissic rocks, sometimes hornblendic, at others micaceous; while non-foliated rocks of similar mineral constitution also occur, which may be regarded as syenite and granite. Beds of much finer texture are also met with within these areas, but the general character of the two masses is a coarsely crystalline one.

The contrast between these rocks and those which constitute the other portions of the range, which consist mostly of schists and thinly bedded gneissic rocks of finer texture, has been specially noticed both by the late Professor John Phillips* and by Dr. Holl.

* "Schistose rocks more or less approaching the character of gneiss are more abundant in the Malvern Hills than might be expected. They occur principally in the West Raggedstone Hill, about its summit; in the northern parts of the Midsummer Hill, and in the hills south of the Wych; but there are various other more limited exhibitions of such compounds." (Mem. Geol. Surv. vol. ii. pt. 1, p. 43.)

The first, or northern, coarsely crystalline mass is cut off on the south by a fault near the Wych Pass; while the other coarsely crystalline mass is bounded by a fault on the north of the Herefordshire Beacon, and by another which cuts across Swinyard's Hill, near the highest part of the ridge. It is to these three faults that I would specially direct attention, as they appear, from adjacent lithological evidence, to be the principal dislocations of the chain.

We will deal first with the northern mass. Dr. Holl states* that there is, nearly opposite the ravine (the Dingle) which separates the Worcestershire Beacon from Summer Hill, a fault which "has carried the Woolhope Limestone, on its southern side, 30 yards further to the west."

Meeting with breccia on the eastern slope of the range in the vicinity of St. Ann's Well, it occurred to me that it might indicate a fault and that the line of fault just alluded to, and which is shown on the map accompanying Dr. Holl's paper, would, if produced, touch the spot at which this breccia occurs. Drawing such a line across the Ordnance six-inch scale map, I endeavoured to trace the breccia, and found a small exposure of it just where the line crossed the ridge of the hill, above and a little to the south of the head of the Dingle. Several hours of search for further evidence resulted in the discovery of breccia at various points, near the line, but sufficiently far from it to show that, if the breccia indicated a fault, it was either very sinuous or, more probably, was itself faulted by transverse dislocations. I think, however, it may be assumed that a fault does actually cross the range at this point; for, apart from the occurrence of breccia, the strike of the rocks composing the Worcestershire Beacon does not agree with the general strike of those on the other side of a line drawn along the Dingle and over the ridge to St. Ann's Well.

Roughly classifying the chief rocks of the Malvern axis, we may separate them into three groups, viz. :—

Upper group = Schists and fine-grained gneiss.

Middle group = Fine- and medium-grained gneiss.

Lower group = Medium- and coarse-grained gneiss, with diorite and granite.

Between these groups there exist no definite lines of demarcation, all three groups being composed of alternating beds of variable texture.

The Upper group is, however, specially characterized by the prevalence of schists, while the Lower group consists mainly of beds of very coarsely crystalline gneiss alternating with granite, syenite, and diorite.

The range from the extreme north to the Wych consists mainly of the Lower, with perhaps the base of the Middle group.

From the Wych to the Herefordshire Beacon the rocks belong chiefly to the Middle group. But it seems probable that some of

* *Op. cit.* p. 95.

the highest beds a little south of Malvern Wells should be referred to the base of the Upper group.

The Herefordshire Beacon is probably composed chiefly of the top of the Lower and bottom of the Middle groups, but exposures of rock are not very numerous; while the northern part of Swinyard's Hill belongs, I believe, to the Lower group. South of the fault which crosses Swinyard's Hill down to the south end of the range the rocks belong to the Upper group, except perhaps the southern portion of Midsummer Hill, which may represent the top of the Middle Group.

In support of such evidence as appears to me to denote repetition of the gneissic beds, I cannot do better than quote the sequence of rocks recorded by Dr. Holl in various parts of his paper, since, although he disclaims any belief in the repetition of these beds, his observations are in most instances of a much more detailed character than my own. Thus on pp. 76 and 77 of his paper he gives a list of the beds traversed in passing from the southern to the northern end of Swinyard's Hill, stating the approximate thicknesses as shown along the crest of the hill.

Beginning at the south end he records:—

	ft.	
Micaceous schist and fine-grained gneissic rocks, with a few subordinate bands of hornblende-schist	665	
Fine-grained red granulite	95	
Fine-grained gneissic rocks and mica-schist, with a few narrow bands of hornblende-schist	565	} ft. 680
Hornblende-schist.....	15	
Mica-schist	15	
Unseen	85	

Here we have, assuming his granulite to form the axis of a fold, 665 feet of rock on one side, corresponding more or less precisely in lithological characters with 595 feet of rock on the other side, with a margin of 85 feet of unseen rock to supply a deficiency of 70 feet.

These beds belong to what I have here termed the Upper Group. They are succeeded on the north, according to Dr. Holl, by trap-rock, micaceous and hornblendic schists, and fine-grained gneissic rocks with subordinate bands of hornblende-schist. Then follows what I conceive to be another, but a minor, fold, viz.:—

	ft.
Diorite, rich in hornblende, with small quartzofelspathic veins	22
Schist	3
Diorite, rich in hornblende, with many quartzofelspathic veins	25

Here, then, judging by the approximate thicknesses, we have in all probability a repetition by flexure.

If the coarsely crystalline rocks forming the northern part of

Swinyard's Hill be a re-emergence of the beds forming the Worcestershire Beacon, it then becomes interesting to compare the immediately superincumbent rocks in the Herefordshire Beacon and those in the tract lying between the Wych and the Worcestershire Beacon; and we may, for this purpose take Dr. Holl's statements as a close approximation to the truth.

In the Herefordshire Beacon he records the presence of gneissic rocks, both hornblendic and micaceous, mica-schists, hornblendic rock, and large granite veins.

From the Wych to halfway up the southern slope of the Worcestershire Beacon he also notes the occurrence of mica-schists, hornblende-schists, gneissic rocks, diorites, granitoid rocks, and granite veins. In this series, out of a roughly paced distance of 677 yards, about 400 yards consists of rocks described as schistose and gneissic, and it therefore seems quite possible that they are the northern representatives of the rocks forming the Herefordshire Beacon, which, as already mentioned, may probably be referred to the upper part of the Lower and the lower portion of the Middle groups. In these questions of correlation I speak with great diffidence and must disclaim any wish to dogmatize. I would rather *suggest*, leaving future observers to draw their own conclusions. The probability of the repetition of beds here indicated has gradually forced itself upon me, both from field-work and in the endeavour to construct an intelligible section * through the range; and, on reference to the latter, it will be seen that the elevations and subsidences of the larger rock-masses have, I think, often occurred somewhat unevenly, while, in addition to this, I believe that some of them have sunk more or less to the east or west during the movements which have shattered and faulted the ancient ridge.

Throughout this paper I have spoken of the bands of gneiss, schist, and other rocks which constitute the chief mass of the Malvern Hills, as *beds*. This has been done partly for the sake of convenience and partly because the foliation of these rocks seems, as a rule, to be parallel to the divisional planes which appear, on the ground, to represent stratification. Aware of the difficulties which environ questions connected with foliation, I would, indeed, prefer to employ the expression *divisional planes* in lieu of stratification, bedding, or any more precise term. Darwin, whose observations on this subject are, in the main, opposed to the assumption that directions of foliation agree with those of bedding, has remarked that the strike of the foliation in most countries lies parallel to axes of elevation †; but if the ridge of the Malvern hills be an axis of elevation, the general law which he here enunciates is apparently violated throughout a considerable part of the range.

That such repeated change in the strike of the divisional planes

* The views of the late Professor Phillips, although given in considerable detail in the Memoirs of the Geological Survey, are simply expressed on the published sections by a wash of vermilion.

† 'Geological Observations on South America,' 1846, p. 166. See also Scrope's 'Volcanos,' 2nd ed. 1862, p. 299.

may have been brought about by the faulting of rocks in which there may have been once a persistently uniform strike, is, however, a possibility not unworthy of consideration*. On the other hand, the arguments in favour of the divisional planes being old planes of bedding appear to rest on the parallelism of the foliation to the divisional planes, on the seeming interstratification of rocks which exhibit no foliation, on the marked differences in texture shown by adjacent bands or beds, and also on the differences which occur in their respective mineral constitution. If we assume these rocks to be metamorphosed sediments, it follows that they were originally bedded, but it does not necessarily follow that they were all subsequently affected by cleavage; and we do not therefore seem justified in the inference that the foliation in this case is parallel to structural planes which *may* have existed, to the exclusion of the possibility that it may be parallel to others which, if the rocks be metamorphosed sediments, we feel assured *did* exist †.

The reference of cases of more or less advanced metamorphism, and the accompanying phenomenon of foliation, to the shearing or creeping movement of one rock-mass over another, may induce many to search in the Malvern range for evidences of disturbance other than those already mapped as faults. Pending the result of such inquiries, it seems better to leave one's mind in a receptive state than to crowd it with opinions of questionable value.

In the meanwhile strikes and dips indicate the directions and inclinations of structural planes; but whether those planes denote an original stratification is an open question and one upon which it seems unsafe to express any decided opinion.

The upheavals and plications which the older rocks have undergone render it more than likely that in many instances the steeply inclined planes of foliation do actually agree with steeply and similarly inclined planes of original stratification in rocks in which cleavage has not been induced, at least to some extent and along parallel portions of folds. On the other hand, the facts recorded by good and competent observers show that in a great number of cases unanswerable proof exists that often, over wide areas, the planes of foliation agree with planes of cleavage, and do not in any way correspond with planes of original stratification.

Interbedded lavas and other eruptive rocks are also frequently present in most of the older formations, and it is therefore needful to remember this in accounting for some of the more strongly marked lithological differences in contiguous bands.

* The foliation was developed in the range before the faults were formed, since the faults cause marked changes in the direction of foliation. In describing the old ridge of the Malvern Hills as an axis of elevation, we are probably expressing merely a partial truth, since the ridge is, most likely, only an upcast portion of an axis of elevation, disrupted by north and south fissures.

† The late David Forbes considered that the direction of foliation agreed in all cases with the planes of least resistance, whether planes of stratification or cleavage, or, in eruptive rocks, with "striae of fusion." ("The Structure of Rock Masses," Popular Science Review, vol. x. p. 236.)

Again, we must remember that cleavage- and other superinduced structural planes do not bound any marked differences in texture or, more especially, in mineral constitution, unless they agree with planes of stratification; and this appears to be a matter worth some consideration, for, if foliation invariably agree with planes which are not planes of stratification or lamination, we have to account for the very marked differences in texture and often in mineral constitution which are frequently met with in metamorphic rocks, and which certainly simulate, even if they do not actually represent, bedding. In a district such as the Malverns it is most easy to be led astray by appearances, and amid the many tempting possibilities which present themselves a wrong one may be chosen. It may be that I have done so in treating these gneissic and schistose bands as stratified beds of rock; but, if so, the error begins and ends with the treatment; for although I am inclined to believe that the divisional planes, with which the foliation appears to be parallel, may be planes of original stratification, and, although I have based the accompanying section upon such a possibility, I regard these planes for the present merely as *structural planes of some sort*, between which the rocks exhibit divers lithological characters*.

Note to accompany the Plans and Section.

For the sake of clearness two plans are given in juxtaposition, on one of which, fig. 2, only the faults are shown. Those given on Dr. Holl's map are represented by continuous thick lines, while my own extensions of them are indicated by dotted lines. The outcrops of the Upper Llandovery beds and the Woolhope limestone on the western flank of the range serve to show the direction of the displacements produced by some of these faults.

On the other plan, fig. 1, strikes and dips as well as faults are represented, those strikes recorded by Dr. Holl being shown by continuous strokes, while those which I have added from observations made on the ground are denoted by dotted lines. The accompanying section (fig. 3) must be regarded as more or less diagrammatic, its purpose being to illustrate the views put forward in this paper concerning the *general* structure of the range.

To render the section less confused, the trap-dykes and the numerous granite or pegmatite veins which have been described are omitted, since although there is abundant evidence that some of them are intrusive, it seems by no means certain that many of those which follow the general strike of the beds do not actually belong to the gneissic series in which they occur.

* During the completion of the first part of this paper, in which the work of Dr. Harvey B. Holl is so frequently cited, came the sad intelligence that that skilled geologist had been taken from our ranks.

He leaves to us in his writings a lasting memorial of conscientious research.

Fig. 1.—General Plan, showing Dips, Strikes, and Faults.

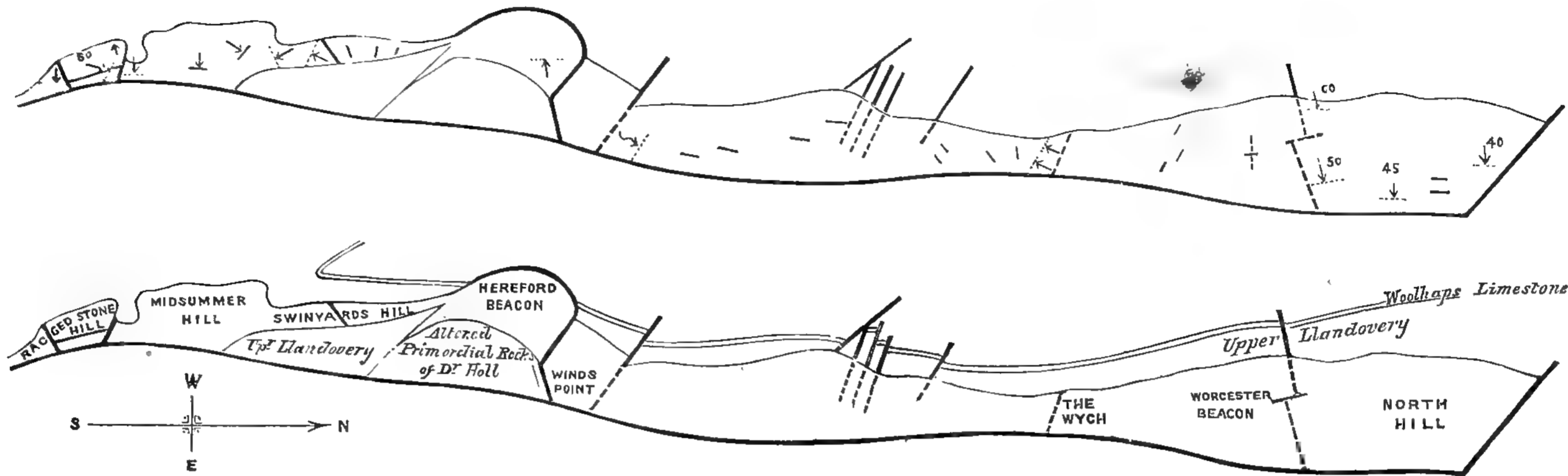
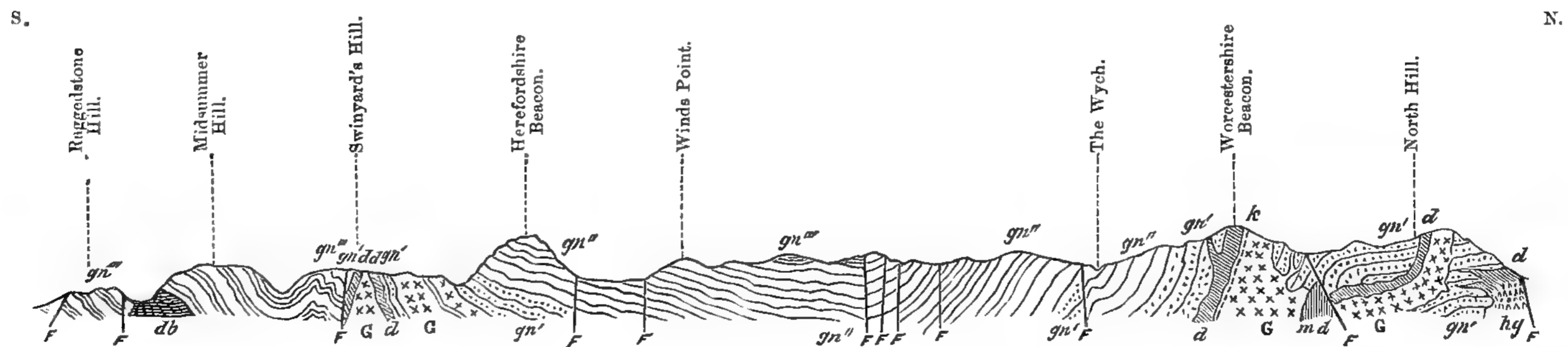

Fig. 2.—General Plan of the Malvern Range, indicating Localities and Faults. (Scale 1 inch to a mile.)

Fig. 3.—Diagrammatic Section from South to North, through the Malvern Hills.



<p>gn''' = Upper Gneissic Series, including mica-schists, quartzites, and fine-grained gneiss.</p> <p>gn'' = Middle Gneissic Series. Foliated rocks of medium and fine texture.</p> <p>gn' = Lower Gneissic Series. Foliated rocks, mostly of coarse texture.</p> <p>FF = Faults.</p>	<p>db = Diabase.</p> <p>d = Diorite.</p> <p>md = Mica-diorite.</p>	<p>hg = Hornblende Gabbro.</p> <p>G = Granite, including Hornblendic Granite and [Quartz-syenite].</p> <p>k = Granulite.</p>
---	--	--



The greatest vertical displacement indicated in the section is connected with the fault which crosses Swinyard's Hill, and, as drawn, it would appear to be about 3000 feet; but it is very probable that this amount of throw may be divided between this and two other possible faults, one of which may occur in Phillips's "Silurian pass" on the north of Swinyard's Hill, while the other may be situated in "The Gullet" between Swinyard's Hill and Midsummer Hill. This view derives some support from a statement made by Dr. Holl to the effect that "the several passes which divide the chain of the hills at intervals are probably, some of them at least, determined by lines of fault, as the direction of the strike of the rocks on opposite sides of these passes is, in some cases, abruptly altered" *.

No sharp demarcations occur between the Upper, Middle, and Lower Archæan groups which I have here ventured to propose. The very existence of any one of these groups depends upon the predominance or paucity of schistose beds, upon characters dependent upon coarseness of crystalline structure, thickness of bedding, and, in fact, upon the *general* nature of the rocks which constitute each group.

PART II.

On the Rocks of the Malvern Hills.

In the first part of this paper the general structure of the Malvern Range was considered; but, at the time it was written, I had not microscopically examined the rocks which were collected during my stay in that district.

The details of this microscopic examination mainly constitute the second part of this paper; and I may here state that the microscopic evidence does not appear to me to disagree in any important respect with the views advanced in the earlier communication, except that truly eruptive rocks are more plentiful in the range than I had at first imagined. The following details relate to specimens which were selected as typical:—

No. 1. *North Hill. Largest quarry on North face of hill.*—Coarsely crystalline rock, consisting of pinkish-brown or flesh-coloured felspar, black hornblende, small scales of dark mica, and some quartz. This rock shows very coarse and strongly marked foliation, the hornblende and mica forming irregular and somewhat lenticular streaks, which are often an inch or more in breadth and are rudely parallel; but the bands do not appear to be continuous, as a rule, for any great distance, and a band frequently thins out altogether. This is the coarsest example of foliation I have met with in the Malvern range. Under the microscope some of the larger felspar-crystals are seen to be microcline, the twin-lamellæ crossing approximately at right angles and undergoing maximum extinction when rotated 15°. Orthoclase twinned on the

* *Op. cit.* p. 95.

Carlsbad type is also present, and, judging from the angles of extinction, there is more or less andesine. Apatite crystals are numerous, and magnetite is also plentiful, occasionally in octahedra, but mostly in irregularly shaped patches. Quartz is plentiful, and it contains great numbers of fluid lacunæ which frequently lie in more or less well-defined bands, an arrangement which is probably due to pressure, as pointed out by Prof. Judd in the quartz-grains of certain crushed quartzite-pebbles; but in this rock the stresses have been exerted in so many different directions, owing to the coarsely crystalline and mixed mineral constitution of the rock, that the bands of lacunæ seldom exhibit any approximate parallelism, except in one and the same crystal. The bubbles contained in the liquid of many of these lacunæ exhibit spontaneous movement. A bubble in one of the largest lacunæ shows this spontaneous motion very perfectly, and the drawing (Pl. XXI. fig. 8) roughly indicates the course which it followed while watched for about a minute. Occasionally well-formed tabular crystals of specular iron occur in the quartz. The apatite crystals lie within crystals of hornblende and quartz and also within patches of magnetite, and evidently represent the first-formed constituents of the rock.

Pl. XIX. fig. 1 shows the coarsely crystalline character of this rock. On the right, a portion of a large crystal of hornblende is represented, with a few included crystals of apatite; the remainder of the figure shows portions of felspar-crystals and some interstitial quartz. The rock is a foliated quartz-syenite or hornblendic granite. The paucity of mica, however, hardly entitles it to the latter name. Gneissic quartz-syenite is, perhaps, the most appropriate term to apply to it.

No. 2. *North Hill. Largest quarry. North face of the hill.*—A rather finely crystalline dark greenish-grey rock, with pale greenish-grey streaks varying from a millimetre to a centimetre in breadth. This banding is sometimes very even and parallel, the rock splitting more or less readily along the pale greenish bands. In places the bands are less regular and have a tendency to branch.

Under the microscope the pale greenish streaks are seen to consist in great part of epidote, which has probably resulted from the alteration of hornblende. Some green magnesian mica is also present. The section contains one crystal in which the change of the hornblende has only been partially effected, portions still showing the characteristic cleavage and strong pleochroism.

Much of the felspar appears, from the extinction-angles, to be labradorite. Quartz is present in irregular patches, and contains numerous fluid lacunæ, generally ranged in lines, which, however, do not correspond in direction in the different crystals. The section also shows some good crystals of apatite. There are some portions of the preparation, consisting possibly of cordierite, which have been altered into a mass of minute fibrous crystals, irregularly felted, and showing, although colourless, strong absorption of light. Their extinction indicates that they are rhombic, and it is probable that they are sillimanite or natrolite. Magnetite is present, but only in small quantity.

An especially noteworthy point is the great difference in texture between this rock and the rocks with which it is associated. The latter are very coarsely crystalline and extremely rich in hornblende. This rock, on the contrary, is of much finer texture, and one of its chief constituents is epidote, a mineral of secondary origin. The fibrous alteration-product already mentioned (sillimanite or natrolite) chiefly characterizes those particular bands in the section which give the foliated appearance to the specimen.

There is no elongation of the quartz- and other constituent crystals to indicate that the banding of the rock is due to stresses and earth-movements, which in some cases are known to induce foliation and schistose structure in eruptive rocks, and it seems by no means improbable that this rock, in its earlier condition, possessed such banded structure as now exists in it (Pl. XIX. fig. 2), and that this banding resulted from the accumulation of hornblende &c. in certain planes*. These, I believe, were planes of stratification; and I am disposed to regard the rock provisionally as a highly altered sedimentary deposit or an altered and bedded volcanic tuff. Indeed, it seems very probable that in the earlier periods of the earth's history, when sedimentary rocks must necessarily have formed a far smaller proportion of the earth's crust than they do now, the products of denudation were chiefly derived from rocks of an eruptive type, and deposits formed of such materials would approximate more or less closely in mineral constitution to beds composed of truly volcanic ejectamenta. The sedimentary rocks of later date consist, in great part, of partially decomposed and triturated materials derived from the repeated partial decomposition and trituration of rock, and there is, consequently, less probability now of the sedimentary deposits resembling volcanic tuffs than there was in Archæan times.

The minute structure of the rock is not gneissic or schistose, and its fissile character is dependent upon the layers of epidote, which give it its banded appearance.

No. 3. *North Hill. Easternmost quarry on North side.*—This is a coarsely crystalline rock apparently consisting of black hornblende and flesh-coloured felspar, and in which traces of foliation are only perceptible in large specimens.

Under the microscope the rock is seen to consist of hornblende, triclinic felspars, magnetite, and apatite. The felspars are mostly, if not exclusively, triclinic, and are, as a rule, more or less altered by the development either of felsitic microcrystalline matter, or by minute scales, with here and there elongated negative crystals sometimes filled with decomposition-products. In one of these cavities a bubble is perceptible. All these results of alteration follow, as a rule, the direction of twin-lamellæ, although at times

* In accordance with what is stated in the concluding pages of this paper, I may add that it is possible that such a rock might result from the crushing and chemical alteration of a diorite; and the proximity of diorite would lend support to this view. The microscopic evidence does not, however, appear to favour such an hypothesis.—*June 28, 1887.*

they pass in parallel lines across such lamellæ without any accompanying twin-lamellation; and in such cases they sometimes appear as dark opaque rods, probably the edges of thin tabular crystals of minute dimensions.

These alterations are evidently similar to those described by Prof. Judd under the term "Schillerization"*; and it would have been superfluous to figure them, since like examples are admirably delineated in pl. x., vol. xli. of this Journal. By reflected light some of these alteration-bands appear of a pale greyish-white colour; they are more opaque than the unaltered parts of the felspar, and it seems highly probable that the minute scales, which in great measure made up these bands, are kaolin.

In one or two cases the felspar crystals appear to undergo parallel extinction; and bearing in mind the low extinction-angles of some of the triclinic felspars, notably in basal sections of oligoclase and andesine, I have felt some doubt in referring such crystals to orthoclase or to a micro-perthitic growth of that mineral with another felspar. There appears to be no perceptible change of tint when a Klein's plate is employed, and it seems possible that the very regular parallel bands of decomposition-products may, in this case, be following a direction of cleavage in a monoclinic crystal. Due precaution was of course taken to insure the accurate crossing of the nicols. I am, however, still doubtful whether these crystals can be regarded as orthoclase. Some of the felspars, indeed a large proportion of them, appear, from their extinction-angles, to be labradorite. Twinning on both the albite and pericline types may sometimes be met with in the same crystal. Little or no quartz is present, and the rock may be regarded mineralogically as diorite, petrologically as a gneissic diorite or hornblendic gneiss. The foliation of the rock is scarcely evident in the microscopic section, except in one or two places where the smaller hornblende crystals show a tendency to form short and irregular bands (Pl. XIX. fig. 3). The dioritic character of the rocks of the North Hill was duly recognized more than twenty years ago by Dr. Harvey B. Holl †.

No. 4. *North Hill. Easternmost quarry, North end.*—A very coarsely crystalline rock consisting of blackish-green crystals of hornblende, ranging from a quarter of an inch in diameter to smaller dimensions, and flesh-red felspar. This is one of the most coarsely crystalline and profusely hornblendic rocks in the whole range.

Under the microscope the larger proportion of the rock is seen to consist of hornblende in large crystals, which by transmitted light appear of a green colour. The pleochroism is strong and the cleavages are well defined. Their boundaries are, however, irregular, as are those of the felspar crystals. The latter have undergone much alteration, so that it is difficult to ascertain their optical characters. Some of them, however, are plagioclastic and tolerably

* "On the Tertiary and Older Peridotites of Scotland," *Quart. Journ. Geol. Soc.* vol. xli. p. 376.

† "On the Geological Structure of the Malvern Hills" &c., *Quart. Journ. Geol. Soc.* vol. xxi. p. 83.

fresh, while the majority show indications of twin-lamellation. Some crystals of apatite are present, and there is a little quartz containing fluid-enclosures; but the latter mineral forms only a very small proportion of the rock, just enough to entitle it to the name of quartz-diorite. Taking the coarsely crystalline structure of the rock into account, it should, perhaps, rather be termed a hornblende-gabbro. It does not appear to be foliated, and is probably an intrusive rock. Pl. XIX. fig. 4 shows portions of the large hornblende and felspar crystals as seen by ordinary transmitted light and magnified 55 diameters.

No. 5. *North Hill, near the top, South side.*—A rather coarsely crystalline dark iron-grey rock, consisting apparently of hornblende and felspar crystals, the former being, as a rule, the larger. The specimen exerts a moderately strong attraction when brought near the magnetic needle.

Under the microscope it is seen to consist of hornblende, triclinic felspars, magnetite, and apatite. The felspar, judging from its extinction-angles, is in most cases labradorite. It is considerably altered, as a rule, especially on the borders of the crystals where they abut against the hornblende, into a microcrystalline-granular material, probably felsitic.

The magnetite occurs in octahedra and in irregularly-shaped patches, the apatite in well-defined crystals.

There is no sign of foliation, either in the specimen or in the microscopic preparation. Quartz appears to be absent; and the rock may be regarded as a good example of a diorite.

No. 6. *North Hill (top).*—A rather fine-grained, pinkish, granitic-looking rock, showing slight foliation.

Under the microscope the section shows felspar, quartz, hornblende, magnetite, apatite, and kaolin.

The felspars appear to be, in part at least, triclinic, but as a rule they are much decomposed. A very little mica may be present. The rock is essentially a quartz-syenite or hornblendic granite (Pl. XX. fig. 1). There is no evidence to show that it is a metamorphic rock. From its rather fine texture it may be regarded as an intrusive sheet or dyke of no great extent.

No. 7. *North Hill, just south of Ivy Scar Rock (bench-mark).*—A very fine-grained dark-grey rock, resembling the whin of the North of England in general appearance.

Under the microscope the felspars show the twin-lamellation characteristic of triclinic felspars, and the greater number of the sections give extinctions of between 5° and 6° and between 15° and 16° . It would appear therefore that the dominant, if not the only, felspar is labradorite. The other constituents are hornblende, magnetite, and apatite. The apatite occurs in well-formed hexagonal prisms*, the hornblende in crystals which exhibit no regular boundaries, while the magnetite, which is plentiful, occurs in octahedra or in irregular patches. Some opaque white matter is also present;

* A group of seven individuals occurring in this rock is shown in Pl. XXI. fig. 9.

it results from the decomposition of the felspar, and is probably kaolin.

The rock is a diorite (Pl. XIX. fig. 5).

No. 8. *Quarry just above West Malvern Church.*—A greenish-grey gneissic-looking rock, with very minute micaceous scales. The rock varies in texture, pinkish felspar occurring in some of the bands in rather coarse crystals.

Under the microscope the chief constituents are seen to be triclinic felspars, biotite, epidote, apatite, a little quartz, and several decomposition-products. The biotite appears, by transmitted light, to be mostly of a sea-green colour. The felspars often contain great numbers of crystals, frequently mere microliths, which undergo parallel extinction and are probably mesotype. The rock is a micaceous gneiss.

No. 9. *Quarry just above West Malvern Church.*—A foliated rock, consisting of flesh-coloured and narrow dark-greenish bands. The former appear to be chiefly felspar, sometimes showing crystals a quarter of an inch in length.

Under the microscope the rock is seen to be composed of microcline in large crystals without any regular boundaries, and showing the characteristic crossed twin-lamellation very distinctly, with the usual extinction-angles; quartz, biotite forming thin irregular bands which mark the foliation of the rock, a little epidote and irregularly shaped and sparsely distributed grains of magnetite or titaniferous iron, probably the latter, as the grains are sometimes surrounded by an opaque, yellowish-white substance, which may be leucoxene. In general terms the rock may be designated biotite-gneiss. The foliation is shown in Pl. XIX. fig. 6.

No. 10. *Large quarry (Leighton's) at the mouth of the Dingle, between the Worcestershire Beacon and North Hill.*—A fine-grained, bluish-grey, crystalline rock, resembling whin, and showing a few minute specks of pyrites. The specimen selected is an average sample of the stone now being quarried for road-metal. The rock strongly attracts the magnetic needle.

Under the microscope it appears to consist of pale-green hornblende considerably altered (but crystals occasionally give an extinction-angle of 19° from the vertical axis), biotite, lath-shaped crystals of felspar much decomposed, but some tolerably fresh, showing micro-pegmatitic structure, and others twin-lamellæ in which the extinctions indicate labradorite. Magnetite is plentiful, and there is a little pyrites. The biotite is of a green colour; and it is a matter of some difficulty to distinguish between it and the hornblende, as they are often intimately associated. The rock is apparently an altered mica-diorite (Pl. XIX. fig. 7).

No. 11. *Worcestershire Beacon. North side near the summit.*—A very fine-grained pale pinkish-grey crystalline rock resembling elvan or granulite. Seen under a pocket-lens it appears to consist of pinkish felspar, quartz, and minute deep-red grains which are seemingly garnets. Under the microscope the constituents are seen to be those already enumerated. The grains composing the rock are all of them

irregular in form and appear to be bound together by a cryptocrystalline cementing material. The felspar appears to be orthoclase: the garnets are only to be recognized by their isotropy, while the quartz contains numerous fluid lacunæ, some of them with bubbles which exhibit spontaneous movement when examined under a power of about 800 linear.

The rock is a granulite and, in common with rocks of this class, is remarkably tough under the hammer. Portion of a thin section as it appears between crossed nicols and magnified 55 linear is shown in Pl. XIX. fig. 8.

No. 12. *Worcestershire Beacon. North side near summit.*—A granitic-looking rock, coarsely crystalline and apparently composed of quartz, pink felspar, and mica.

Under the microscope the constituents are seen to be microcline, quartz, biotite, and apatite. Here and there a little limonite and specular iron occurs; one or two small crystals of hornblende may be seen, in which the angle $c:c$ is exceptionally large, being over 30° . The pleochroism is somewhat distinct. The biotite, when examined under a tolerably high power, is found to be spotted with stains and patches of ferric oxide, and in some places scales of specular iron are developed. In other cases spicular bodies which, when magnified about 800 diameters, are seen to consist of strings of globulites massed in small fasciculi appear dark and opaque except towards their ends, where their component globulitic strings are frayed out and the globulites are seen to be translucent. These globulitic crystals, for as such they may be regarded, probably represent an early stage in the development of some such mineral as hornblende. Furthermore, they intersect at angles of 60° in basal sections of the biotite, and evidently lie in the directions of the three lines which form the percussion-figure of this mica. In sections normal or oblique to the cleavage of the biotite they appear merely as dark lines which follow the cleavage-planes. There is a certain resemblance in this arrangement which recalls the well-known crystals of specular iron in the Pennsbury mica, but the latter have sharply defined boundaries. Crystals and scales of specular iron also occur in the biotite of this Malvern rock, associated and sometimes in contact with the globulitic crystallites just described; but here, too, the specular iron exhibits sharply defined boundaries, and there is no doubt that whatever the globulitic bodies may be, they represent the incipient development of some mineral which retains any iron it may contain in the protoxide state, since the globulites are either colourless or pale green; but, since the surrounding biotite is of a green colour, it is difficult to say what their colour would be by transmitted light, if isolated. By reflected light the opaque portions of these crystallites, where the globulites have become densely packed, appear of a pale green or greenish white. A drawing of some of them, as seen by substage illumination and magnified 850 linear, is given in Pl. XXI. fig. 6.

The rock is granite. Portion of the section magnified 18 linear is shown in Pl. XX. fig. 2.

No. 13. *Worcestershire Beacon. North side of summit.*—A greenish-grey crystalline rock, apparently composed to a large extent of hornblende crystals varying from about 2 millim. to smaller dimensions. Under the microscope it is seen to consist of hornblende, decomposed feldspars, apatite, and magnetite. The hornblende is very fresh. The cleavages are well defined and the pleochroism strong; a = brownish-yellow, b = dark brownish-green, c = bluish-green. The feldspars are in too advanced a stage of decomposition to admit of any determination, but a few of them show faint indications of twin-lamellation. The magnetite occurs in irregular grains (Pl. XX. fig. 3).

The rock is possibly a syenite, probably a diorite. The altered condition of the feldspar precludes a decided opinion.

No. 14. *Worcestershire Beacon. Summit.*—A crystalline rock apparently composed of dark green crystals of hornblende and pinkish-grey feldspar.

Under the microscope the constituents are found to be hornblende, triclinic feldspars which show the extinction-angles of labradorite, apatite and magnetite. A little quartz is also present, but it certainly cannot be regarded as an essential constituent of the rock, which is a diorite. The section shows no traces of foliation. It is an eruptive rock, and its general appearance *in situ* is that of a vertical dyke about 18 inches to 2 feet broad.

Portion of a section magnified 18 linear is shown in Pl. XX. fig. 4, as seen between crossed nicols.

No. 15. *Worcestershire Beacon. North side of summit.*—A very fine-grained, pale bluish-grey crystalline rock. Epidote in small grains, triclinic feldspar, quartz, and sparsely disseminated grains of magnetite appear, under the microscope, to be the chief constituents of this rock (Pl. XX. fig. 5). Here and there a faintly defined linear arrangement of the epidote may be seen, as shown in the drawing, but it can hardly be regarded as foliation. The rock is probably an altered quartz-diorite, but it may, in its present condition, be looked upon almost as epidosite.

No. 16. *Herefordshire Beacon. North side, near top of ancient British Camp.*—A fine-grained crystalline greenish-grey rock with small blackish-green porphyritic crystals. Under the microscope the latter are seen to be hornblende, and ragged fibrous-looking crystals of this mineral appear to constitute a large proportion of the rock and, from their arrangement, to give rise to a wavy and faintly foliated structure (Pl. XX. fig. 6). Minute granular crystals of epidote are plentiful, while patches of magnetite, often accompanied by a little hæmatite, are common. The remainder of the section appears to consist of feldspar, for the most part decomposed.

Judging from the general appearance of the rock under the microscope, it seems highly probable that it is an altered diabase or andesite tuff; but it is also possible that the foliation in this, as in some other cases, may be due to shearing.

No. 17. *Herefordshire Beacon. North side, near top of British Camp.*—Dark bluish-grey to reddish-brown crystalline rock, show-

ing, on a cut surface, small reddish-brown and greyish-white blotches on a dark bluish-grey ground.

Hornblende, triclinic feldspars, quartz, epidote, apatite, and a little pyrites and chlorite appear, under the microscope, to be the principal constituents of this rock.

Some of the feldspars, judging from their extinction-angles, are labradorite, while others occasionally give an extinction-angle of 39° , and must consequently be referred to anorthite. The hornblende appears of a pale green colour by transmitted light; it occurs in irregularly bounded crystals which show the characteristic cleavage. The epidote occurs in moderate-sized crystals and in small grains. The quartz has segregated so as to form distinct bands, which alternate with the very irregular bands of hornblende, epidote, &c., through which more or less quartz is also disseminated.

It is difficult to assign any precise origin to this rock; it might quite well have resulted from the degradation of syenitic rocks or hornblendic gneiss. It may even be regarded as a fine-grained hornblendic gneiss, and it is to the latter rock that I am inclined provisionally to refer it. Its general appearance by ordinary transmitted light under an amplification of 18 linear is shown in Pl. XX. fig. 7.

No. 18. *Herefordshire Beacon. Close to and on the west of the Cave.*—Rather coarsely crystalline dark greenish-grey rock resembling basalt.

Under the microscope the constituents are seen to be augite, triclinic feldspars, apatite, pyrites, and serpentine (Pl. XX. fig. 8). The crystals of augite are occasionally over $\frac{1}{20}$ inch in length. The characteristic, almost rectangular-intersecting cleavages may be seen in the basal sections. The crystals are intersected by strong and very irregular fissures, frequently accompanied by peroxide of iron, which communicates a rusty stain to the augite for a slight distance bordering the cracks. Here and there minute scales of specular iron may also be seen lying within the substance of the augite. In sections parallel to 010 the measurements of the extinction $c:c$ vary but little from 38° . These augite-crystals barely exhibit a trace of pleochroism. The feldspars show by their extinction-angles that some of them are labradorite, while others, and those perhaps the more numerous, are anorthite. The latter show, as a rule, less twin-lamellation than the labradorite, and the extinction-angle measured in four or five sections is 37° and sometimes 38° . Pale green patches of serpentine are common in the rock and probably result from the alteration of olivine. No distinct forms which can be referred to crystals of olivine, however, are to be met with in the preparation. The pyrites occur in very irregularly-shaped patches often traversed by a labyrinth of channels and generally very much cut up by branching cracks, which, when seen by reflected light, appear to be filled with hæmatite, while the pyrites is very frequently seen to be intimately associated with magnetite, the latter mineral always enveloping the pyrites. From its mineral constitution the rock appears to be related to eucrite.

An analysis of a rock from the same locality, no doubt the same

rock, has been given by the Rev. J. H. Timins (analysis xxxvii.* This analysis is subjoined, together with one of eucrite lava from Thjórsá in Iceland †:—

	Silica.	Alumina.	Iron Oxides.	Lime.	Magnesia.	Loss on Ignition.	Alkalies and Loss.
xxxvii.....	49.37	15.80	10.82	11.90	6.40	4.00	2.59— 99.98
Eucrite	49.60	16.89	11.92	13.07	7.56	...	1.44—100.48

In the first analysis traces of oxides of manganese and copper are recorded, and in the latter analysis traces of manganese, cobalt, and nickel. In the latter analysis, also, the iron is all in the protoxide condition, and the alkalies are given as $\text{Na}_2\text{O} = 1.24$ and $\text{K}_2\text{O} = 0.20$.

Mr. Timins ‡ stated that the subject of his analysis contained a few grains of olivine and a little quartz in cavities. He also adds, "Parts of this rock resemble the matrix of the lava of the Capo di Bove near Rome. In its chemical composition it nearly corresponds with that which Bunsen gives for the 'Normal Augite' § of Iceland. Notwithstanding its occurrence in regular beds, its mineralogical character and its chemical composition make it probable that it has *flowed* over the surface."

It is gratifying to find the mineral constitution of this rock, as revealed by the microscope, so well in accord with the results of Mr. Timins's analysis made twenty years ago.

The rock is eucrite- or anorthite-basalt.

The eucrite lava of Thjórsá, the analysis of which I have here employed for comparison, is cited by Von Lasaulx || as an example of a true eucrite, and there seems, therefore, good reason to accept the analysis given by Kalkowsky as typical. The latter authority does not consider the term eucrite well chosen, and deprecates its use.

No. 19. *Herefordshire Beacon. East side, at the back of the Cave.*—Very fine-grained bluish-grey aphanitic rock. Under the microscope it is seen to consist of felspars, chiefly labradorite, augite, titanium-ferous iron, leucoxene, and pyrites in exceedingly minute specks.

The section is traversed by a small vein of epidote enveloping fragments of the adjacent rock and also a little quartz.

The augite appears in irregular grains, few distinctly formed crystals being visible.

The felspars occur in lath-shaped crystals, generally corroded and frequently bent (Pl. XXI. figs. 4 & 5). There is much opaque

* "On the Chemical Geology of the Malvern Hills," Q. J. G. S. vol. xxiii. p. 358.

† Kalkowsky, 'Elemente der Lithologie,' Heidelberg, 1886, p. 130.

‡ *Op. cit.* p. 359.

§ The name Augite was used synonymously with Basalt by some of the earlier writers, and is given, in this sense, by Kinahan, 'Handy-Book of Ro Names,' London, 1873, p. 73.

|| 'Elemente der Petrographie,' Bonn, 1875, p. 316.

white matter in the section, which, as seen by substage illumination, is indicated by the darker parts in Pl. XX. fig. 9. This is probably leucoxene, and it is generally associated with an opaque black mineral, which may, consequently, be regarded rather as ilmenite than as magnetite. The rock is a basalt.

No. 20. *At the back of the Cave. Herefordshire Beacon, overlooking Castle Morion Common.*—A compact pinkish-brown to pale liver-brown rock of felsitic appearance and not unlike some porcellanites, with splintery to small wavy, almost conchoidal fracture, harder than steel, harder, at all events in part, than quartz, since the brilliant pyramidal face of a quartz-crystal was distinctly scratched by sharp corners of the specimen.

Under the microscope the rock is seen to be filled with minute, sometimes irregularly-shaped, but generally nearly spherical granules with apparently a somewhat high refractive index.

The aspect of the section between crossed nicols is that of a felsite, and it appears that the feeble light transmitted under these conditions emanates from portions of the otherwise seemingly structureless parts of the ground-mass, since, as a rule, the minute granules are apparently isotropic. It is, however, difficult to speak positively as to their absolute isotropy. Here and there crystals ranging from $\frac{1}{750}$ inch to smaller dimensions may be seen either isolated or in groups. They are colourless and prismatic in habit. They are traversed transversely to the axis of the prism by lines which may represent a rather irregular cleavage. Between crossed nicols they undergo parallel or straight extinction, and may belong to the rhombic system. I would very doubtfully refer them to topaz, a supposition which is strengthened by the analysis (xlii.) of the Rev. J. H. Timins* of a rock from the same locality, in contact with felstone, in which he detected one per cent. of hydrofluoric acid. An interesting point connected with this rock is an obscure perlitic structure. In the first section examined it was not sufficiently well marked to enable me to form a definite conclusion; but since, in another section off the same specimen, a similar but better-marked structure (Pl. XXI. fig. 7) has been observed, I no longer hesitate to describe the rock as a devitrified obsidian with perlitic structure. It may be the rock analyzed by Mr. Timins, No. xliii., described by him as felstone "of a pink colour," or No. xlv. "Porcellanite, north-east of the cave" †. It is probably the latter, but both analyses are here transcribed:—

	Silica.	Alumina.	Oxide of Iron.	Lime.	Magnesia.	Loss on Ignition.	Alkalies and Loss.
xliii.	77·33	12·3	1·33	5·39	0·91	1·45	1·29
xliv.	78·92	8·18	4·08	5·05	0·48	1·19	2·10

* "On the Chemical Geology of the Malvern Hills," Q. J. G. S. vol. xxiii. p. 360.

† *Op. cit.* p. 360.

The percentage of alkalis is, however, considerably lower than is usual in rocks of this class.

The perlitic structure is chiefly rendered evident by the massing together of the minute granules already alluded to along curved lines. This is indicated in the drawing which was made from a spot in the section which shows the structure best, as it frequently becomes very obscure, owing to the multitude of the granules, so that oftentimes no arrangement denoting perlitic structure can be traced. Even under favourable circumstances it is frequently needful to examine the section attentively before the fact that this structure is present and pervades the entire section becomes evident to the observer. The specimen was collected and labelled as likely to show perlitic structure. It does show it, but it is the most feeble demonstration of the structure that I have ever seen. It is interesting, however, as being the first indication of a vitreous rock in the Malvern Range hitherto recorded, and it may possibly belong to the same geological horizon as the perlitic rocks of the Wrekin, first described by Mr. S. Allport*.

The specimen is a mere surface-chip, and further search in the neighbourhood from which it was derived would certainly yield better material for investigation and probably more satisfactory results.

The apparent banding shown in Pl. XXI. fig. 7 is merely due to alteration, produced by the filtering of water along cracks resulting in a slight rusting; but these cracks, as shown in the drawing, have been faulted by other minute fissures.

No. 21. *Hollybush Pass. Large Quarry on North side of road.*—Average sample of the stone now quarried. Very fine-grained bluish-grey crystalline rock, strongly attracts the magnetic needle. Under a pocket-lens it shows here and there a few scales of silvery mica. Its general appearance resembles that of very fine-grained whin. Under the microscope the rock appears to consist of altered triclinic feldspars, biotite, magnetite, and various products of decomposition. The feldspars, when their extinction-angles can be made out, are apparently labradorite. Numerous but very small apatite crystals are visible; epidote and chlorite are present. The magnetite frequently occurs in octahedra, which now and then, by their reentering angles, are seen to have a parallel grouping. The general impression derived from an examination of this rock under the microscope is that it is a much-altered diabase.

No. 22. *Swinyard's Hill. Commencement of North end of the ridge.*—A very coarsely crystalline rock consisting of red feldspar in large crystals, a greenish mica in small scales, and quartz in crystalline pellets, occasionally nearly half an inch in diameter.

Under the microscope the feldspars are seen to be microcline and orthoclase, the former showing, in polarized light, the characteristic twin-lamellæ intersecting approximately at right angles, the angle of maximum extinction in basal sections being about 15° from the

directions of the lamellæ. The orthoclase also occurs in large crystals. One of those present in the section is twinned on the Carlsbad type. The mica is of a green colour by transmitted light and the crystals are much smaller than those of the felspars. The quartz encloses great numbers of fluid-lacunæ containing bubbles. These cavities are mostly ranged in lines or streams which appear to follow two general directions crossing at a high angle, which, however, varies, as the lines are rather wavy and sometimes converge. By carefully traversing the preparation under the microscope it is seen that the directions of these streams of cavities are tolerably persistent in patches of quartz more or less widely separated, and it is possible that they may be approximately normal to two different directions of stress. The large patches of quartz are seen in polarized light to be made up of smaller patches, each being an individual quartz-crystal; yet the same stream of cavities will pass unbroken through many of these crystals, until, joining with other streams of cavities, it can no longer be traced, or until it reaches the opposite side of the composite area of quartz.

None of the component minerals exhibit any definite crystalline forms. No apatite is present, but a few granules, apparently of epidote, are visible.

The rock is a coarse-grained granite or pegmatite.

No. 23. *Swinyard's Hill. Highest point of the ridge.*—A coarsely crystalline rock composed apparently of dark-green hornblende and pinkish-grey to greyish-white felspar, with a few minute scales of a silvery mica. The chief constituent of the rock, however, appears to be hornblende in large crystals.

Under the microscope the constituents are seen to be hornblende, triclinic felspar, a colourless mica, epidote, natrolite, and magnetite. Of these, hornblende is by far the most important, constituting probably more than three fourths of the rock. The felspars approximate in their extinction-angles, in some cases to andesine, in others to labradorite; but the lamellæ are often bent. They are by no means numerous, and exhibit no well-defined crystalline form. The mica is colourless or of a very pale greenish tint when viewed in thin section by transmitted light. Both epidote and magnetite occur in small irregularly-shaped grains. The natrolite is chiefly met with in the triclinic felspars, in small prisms which polarize in brilliant colours, and, between crossed nicols, undergo straight extinction. Here and there minute scales of specular iron of a bright orange-red colour may be seen in basal sections of the mica. In these sections only a portion of an hyperbola can be seen in convergent polarized light.

The rock is a diorite, and was described as such by the late Dr. Holl*. The Rev. J. H. Timins has also described it in his paper † as “containing hornblende, white felspar and silvery mica. The more micaceous and felspathic portion of the rock was analyzed.” The analysis is subjoined.

* *Op. cit.* p. 77. Where he refers the felspar to oligoclase or andesine.

† *Op. cit.* pp. 363-364. Analysis lx.

Silica = 44.76. Alumina = 16.60. Oxide of Iron = 8.43. Oxide of Manganese = 0.20. Lime = 9.92. Magnesia = 8.56. Loss on Ignition = 2.68. Alkalies and Loss = 8.85.

No. 24. *Swinyard's Hill, North side of highest point of ridge.*—A remarkably coarsely-crystalline rock composed of flesh-red felspar, dark green hornblende, and quartz. This and No. 22 are perhaps the most coarsely crystalline rocks in the whole of the Malvern Range.

Under the microscope by ordinary transmitted light the hornblende appears of a greenish-brown colour, and some minute opaque brown flecks, seemingly of limonite, may here and there be seen in it. The felspar-crystals are mostly very large and exhibit no definite crystalline form, their boundaries being extremely irregular. Some of them are tolerably fresh, others considerably altered. One measurement gave an extinction-angle of about 5° , another, but not a trustworthy one, about 12° . They are probably microcline. The quartz contains fluid-lacunæ with bubbles.

The rock is coarse hornblendic granite or quartz-syenite.

No. 25. *Swinyard's Hill, North side of highest point.*—A rather fine-grained, crystalline, dioritic-looking rock, apparently composed of dark green hornblende and a pale grey or pinkish-grey felspar.

Under the microscope the hornblende appears to be the principal constituent (Pl. XX. fig. 10). It is of a brownish-green colour when viewed by transmitted light. Its pleochroism is strong, a = pale brownish yellow, b = coffee-brown, c = greenish brown.

Where moderately fresh, the extinction-angles of the felspars indicate that they may be in some cases andesine, in others labradorite; but for the most part the felspars are greatly decomposed, and no safe deductions can be formed concerning them, except that they are triclinic. They appear, in most cases, to be replaced by natrolite. Quartz, containing minute fluid-lacunæ, is of common occurrence in the section; but the grains are small, and it forms a comparatively insignificant proportion of the rock, which must be regarded as a diorite.

No. 26. *Swinyard's Hill, just South of the summit.*—A very distinctly foliated crystalline rock, the bands being alternately flesh-red (or a finely crystalline admixture of flesh-red and greyish-white minerals) and dark green, the constituent of the dark green bands being probably hornblende. Under a pocket-lens a few minute scales of silvery-looking mica are visible. The foliation reminds one somewhat of that of the *Schorlschiefer* of Auersberg in Saxony; but in the latter rock the dark bands are intensely black instead of dusky green.

Under the microscope, quartz, magnesian mica, and, apparently, some muscovite and triclinic felspars, especially microcline, are seen to be the principal constituents of the rock. The cleavage-planes in the mica have a general tendency to follow the foliation, which in reality is due to this mineral. The quartz shows streams of fluid-lacunæ, which in nearly all cases run in a direction more

or less at right angles to the foliation. There is something more than accident in this circumstance. By reflected light, a rusty brown colour is seen to pervade the darker bands of the rock, and the darkness of these bands appears to be due partly to the presence of biotite, and partly to that of limonite. The rock is essentially a biotite-gneiss.

No. 27. *Swinyard's Hill, largest Quarry, South end.*—Dark grey, finely foliated micaceous rock. On a cut surface, blotches and streaks of a flesh-red felspar are visible. The rock has an imperfectly fissile structure, and on the schistose planes the micaceous character is, of course, most perceptible.

The description of the microscopic characters of the preceding specimen applies equally well to this, except that there is more muscovite present, and it is still noteworthy that the streams of fluid-enclosures in the quartz again run in a direction roughly normal to that of the foliation.

The rock is a biotite-muscovite-gneiss. The foliated structure of this rock is shown in Pl. XX. fig. 11.

No. 28. *Raggedstone Hill, Eastern Spur at top of hill near the middle, and at the northern end.*—A fine-grained, greenish-grey, micaceous, schistose rock.

Under the microscope, quartz, a little felspar, muscovite, and kaolin appear to be the principal constituents. The quartz occurs in grains and aggregates of grains, which have a lenticular form, and the mica scales lie in wavy films, which separate these lenticular bodies and impart a wavy streaked appearance to a section taken transversely to the schistose structure of the rock. These micaceous streaks are rendered more distinctly visible by an opaque yellowish-white substance which accompanies them, and is probably kaolin. Small scales of mica are also seen traversing individual grains of quartz. The quartz contains numerous fluid-lacunæ, and these, again, frequently lie in streams which in most cases follow directions more or less steeply inclined to the general direction of the micaceous bands.

The rock is a mica-schist. Its foliated character is shown in Pl. XX. fig. 12, where the darker markings represent the micaceous bands.

No. 29. *Swinyard's Hill, large Quarry, South end, at foot of hill.*—An essentially micaceous rock, in colour reddish brown to grey transverse to the direction of fission, but greenish grey, from the predominance of mica, along the planes of fission. The fissile structure is very irregular.

The microscope shows the presence of quartz, felspar, biotite, here and there a grain of magnetite, natrolite, and a very little limonite. Some of the felspar shows twin-lamellation, but it is nearly all in an advanced stage of alteration. It appears to be microcline, as a rule. The biotite is of a greenish colour, and runs in irregular bands. The quartz is in irregularly-bounded crystalline grains, through which run streams of fluid-enclosures at right angles or obliquely to

the direction of the micaceous bands, as already pointed out in the descriptions of specimens Nos. 22 and 26. That the direction of these streams of enclosures is dependent upon causes operating subsequently to the formation of the quartz is evident from the fact that when the section is examined in polarized light the same stream of enclosures will be found to traverse without deflection several crystals which differ from one another in optical orientation.

The rock is a biotite gneiss.

No. 30. *Raggedstone Hill, Eastern Spur, North end, top.*—A very fine-grained, pale, bluish-grey rock, resembling an exceedingly fine-grained quartzite. The rock is very hard, a knife-point making little or no impression on it.

Under the microscope, between crossed nicols, the section presents a general appearance similar to that of the ground-mass of a quartz-porphry, or of a rather coarse microcrystalline felsite, in which occur numerous porphyritic crystals of feldspar and delicate strings and specks of more or less opaque granular matter, which, under reflected light, appears of a yellow-white or pale reddish-brown colour. Under a higher power, however, it is seen that the opacity of these strings and spots is only partial, and that in great part they consist of small translucent greenish or nearly colourless granules of epidote, with much fine dusty matter of a deep green colour, which appears to be allied to chlorite. The porphyritic feldspar seems to be of a mixed character, the angles of extinction in some crystals being apparently very low, in other cases approximating to those of labradorite. Microcline is also present. Some of the feldspar may be andesine.

The rock in some respects resembles granulite, but garnets are absent, and the feldspar is all, or nearly all, plagioclastic. On the other hand, it is not unlike some felsites, especially some of the more coarsely micro-crystalline parts of certain devitrified rocks. I am, however, inclined to regard it as an altered sandstone derived from the disintegration of the older Archæan rocks, and bearing the same relation to them that arkose or millstone-grit bears to granite.

A drawing made from a section of this rock, magnified 25 diameters, is given on Pl. XXI. fig. 1.

No. 31. *Raggedstone Hill, Eastern Spur, North end, top.*—A pale brownish-grey to bluish-grey rock, resembling quartzite strongly impregnated with very minute silvery-looking micaceous scales, and with a schistose structure.

Under the microscope, in polarized light, this rock is seen to be essentially a quartzite, in which a schistose structure is induced by extremely thin micaceous or sericitic films. These are, in some instances, crossed by rather irregular and tolerably broad bands, consisting of quartzite of a much finer texture than that constituting the mass of the rock, and suggesting that another stress has been experienced in a direction approximately at right angles to that

which produced the schistosity of the rock. The quartz-grains, which are quite irregular in form, contain fluid-lacunæ, often ranged in lines, and these streams of enclosures lie sometimes in the direction of the fine-grained quartzitic bands, at others in the direction of the micaceous bands.

The rock may not inaptly be termed a micaceous quartzite-schist.

Part of a section of this rock is shown in Pl. XXI. fig. 2, as seen by ordinary transmitted light.

No. 32. *Raggedstone Hill, Eastern Spur, East side, North end, near the middle.*—A very compact, bluish-grey rock, translucent on the edges, resembling quartzite, with a faint laminated structure, and showing under a pocket-lens numerous minute, glistening, crystalline facets or cleavages.

Under the microscope this is seen to be a quartzite containing numerous but very minute scales of mica, which, in places, show a tendency to segregate in irregular lines. They are not, however, sufficiently numerous in proportion to their size to impart a fissile character to the rock.

No. 33. *Vein, about a foot in thickness, in first quarry on South side of The Wych, Western side of the Malvern Range.*—A very coarsely crystalline rock of a deep flesh-red colour, with spots of greyish or bluish-white quartz.

Under the microscope the felspar appears to be microcline, the extinction-angle generally ranging from about 12° to 15° . The cross-hatched twinning on the pericline and albite types, so common in this mineral, is not to be detected in the section here described, the crystals showing but one set of twin-lamellæ, and in some cases none. The crystals are sometimes cracked and faulted, as shown in Pl. XXI. fig. 3. Some opaque white matter, probably kaolin, is present in small flecks and streaks. The quartz contains fluid-lacunæ, often showing a faint linear arrangement. This is a good example of the pegmatite-veins so common in the Malvern Hills. Of their intrusive character there can be no doubt. An admirable example of a branching vein may be seen traversing schists in an abandoned quarry on the east side of the Raggedstone and towards the southern end of the hill. I am not, however, inclined to think that the coarse pegmatite forming the northern part of the ridge of Swin-yard's Hill is to be regarded as a vein-rock or dyke, or as a series of veins; it is more likely to be part of a deep-seated rock belonging to the lower, and probably to the *lowest exposed* portion of the Archæan series in this district.

In reviewing the results of the microscopic examination of the Malvern rocks, we must in the first place separate those rocks which exhibit foliation or lamination, or of which the origin has been sedimentary, from those which show no such structure, and which must, without doubt, be regarded as eruptive. This is the more needful since much diversity of opinion exists concerning the interpretation which should be put upon the phenomena of foliation. We shall by this means classify the rocks of the Malvern Range into

a banded and an unbanded series, and under the former will come the different varieties of gneiss. For my own part, I am inclined to regard the gneissic rocks of this district as probably being more or less altered volcanic tuffs, or as sedimentary rocks mainly composed of eruptive material derived from the disintegration of rocks of a dioritic or syenitic character. Reasons for and against the assumption of a sedimentary origin for these gneissic rocks have already been given in the first part of this paper, and a section through the Malvern Hills was appended, based upon the hypothesis that foliation in this district corresponded with structural planes which frequently mark lithological differences, and that these structural planes were possibly planes of stratification. We shall find, on comparing the results of the foregoing microscopic examination, that, except in that part of the range which lies south of the fault crossing Swinyard's Hill, the rocks are of a mixed character, being partly foliated and partly devoid of foliation. In the following Table the rocks are placed in three columns, so as to divide the eruptive, the foliated, and the probably and unquestionably stratified rocks:—

	Eruptive.	Foliated.	Stratified.
North Hill	Hornblende-Gabbro, Diorite.	Gneissic Syenite, Gneissic Diorite.	Altered Tuff?
North Hill	Quartz-Syenite.		
North Hill (above West Malvern)	Mica-Diorite.	Biotite-Gneiss.	
North Hill (The Dingle)	Mica-Diorite.		
Worcestershire Beacon	Granulite?, Granite, † Diorite, Epidosite?		
Herefordshire Beacon .	* Eucrite, * Basalt, * Devitrified Obsi- dian.	Hornblendic Gneiss.	Diabase-Tuff?
Swinyard's Hill	Pegmatite, Horn- blende - Pegmatite, Diorite.	Biotite-Gneiss, Bio- tite, Muscovite- Gneiss.	
‡ Hollybush Pass	Diabase.		
Raggedstone Hill	Mica-Schist, Mica- ceous Quartzite- Schist.	Altered Sand- stone, Quart- zite.
††			

† Rocks between a little south of the summit of the Worcestershire Beacon on to Winds Point were not collected.

‡ Rocks of Midsummer Hill were not collected.

†† Rocks of Keys End were not collected.

* These occur in the eastern buttress of the Herefordshire Beacon, and are of Cambrian (?) age, "Altered primordial rocks" of Dr. Holl.

It is evident therefore that the above list gives only a very incomplete idea of the rocks constituting the whole length of the range. By reference to Dr. Holl's paper, these gaps may, to some extent, be filled up, as already indicated in the first part of this communication. From the tabular classification just given, it appears that the North Hill consists partly of rocks which show no foliation, and which we must regard as truly eruptive, and partly of foliated rocks,

which in many cases are, I think, either altered tuffs or are composed of the *débris* of eruptive rocks rich in hornblende. The rocks of the Worcestershire Beacon appear to be mainly eruptive. Those of the Herefordshire Beacon are, I believe, chiefly gneissic; but the exposures are not sufficiently numerous or good to enable me to say much on this point, and the time for more careful examination was wanting. The eucrite, basalt, &c., which I have classed with the general mass of this beacon, occur in a buttress of the hill, which, according to Dr. Holl, consists of "Primordial rocks."

The northern part of Swinyard's Hill is composed of pegmatitic or granitic rocks of varying coarseness. The altered diabase in the Hollybush quarry forms part of the southern end of Midsummer Hill. A vein of pegmatite, consisting in great part of a red felspar, is, at the present time, exposed in the lower part of the quarry. South of Midsummer Hill we meet with fine-grained gneissic rocks, quartzite-schist, quartzite, and altered sandstones, which form, I believe, the highest and least altered part of this Archæan series.

The views advanced in the first part of this paper appear therefore to be, as a rule, borne out by the microscopic examination of the rocks, except that those of a truly eruptive character are much more plentiful than I had at first imagined.

The Malvern Range may, I think, now be regarded as part of an old land where denudation had laid bare certain plutonic rocks, and where volcanic activity was very great; for whether we look upon these gneissic rocks as beds of volcanic ejectamenta, or regard them as of sedimentary origin, there seems to be little doubt that they are composed of the minerals which constitute eruptive rocks, and there appears to be no reason to assume that the alteration of any ordinary sedimentary rocks, such as slates and sandstones, could have resulted in the development of such a vast amount of hornblende. It may be argued that there is no appreciable difference in much of the hornblende occurring in the foliated rocks from that in the adjacent and non-foliated syenites and diorites, and that it is therefore probable that the foliation has been induced in truly eruptive rocks by earth-movements*; yet, granting this, how comes it that *all* of the rocks are not foliated? The pressure or movement which would affect one bed would naturally affect those in its proximity; yet we meet with great variety in these beds both in texture and in structural characters. The facts do not seem to me to bear out the conclusion that earth-movements, at all events in the Malvern Range, have begotten foliation, except, perhaps, on a very small scale. We know too little as yet of the rocks which are formed from the waste of districts composed mainly of eruptive materials. Whence come our hornblende-slates and schists, chlorite-schists, mica-schists, schorl-schists, &c., the constituents of which are either those of eruptive rocks or their alteration-products, such as epidote,

* Such apparently bedded structure, accompanied by differences in texture, is described by Prof. Bonney, in his Presidential Address to this Society (1886), by the name *pseudostromatism*, which he regards as the result of "a crushing *in situ* of zones of the original coarse-grained rock."

chlorite, limonite, kaolin, serpentine, &c.? Some would say that they result from the pressure-metamorphism of eruptive rocks. It is true that, in certain cases, slates of the ordinary kind may be found to graduate into mica-slates as they near an eruptive mass; yet is this the only way in which mica-slates and schists have been formed? Admit that it is, and we may at once grant that the gneisses and schists of the Malverns are but metamorphosed sediments. It may be so: we have yet to settle the limits of metamorphism. On the other hand, it seems well also to suggest the possibility that the materials resulting from the denudation of eruptive rocks go somewhere and form something, and that the resulting rock is consequently likely to resemble those from which its materials were derived, rather than a slate or sandstone. I therefore venture the suggestion that *the gneissic rocks of the Malvern Hills may be composed of the detritus of eruptive rocks*. It is even possible that in an early stage of the earth's history there was little save rocks of an eruptive nature for the denuding agents to work upon, and, if such an assumption were true, these Archæan rocks would claim a far greater antiquity than if they resulted from the metamorphism of stratified deposits.

Again, it is very difficult to say how far the movements which these rock-masses have experienced may have influenced their lithological structure, and whether such movements have resulted in any of the effects attributed to shearing. That such action is implicated to a certain extent in the production of their foliation is highly probable; but how we are to distinguish between the crushing and rearrangement of crushed materials by lateral thrust and the arrangement of detritus by a sorting process (which may take place either in air, in the case of volcanic dust falling on land and rocks disintegrated and recemented *in situ*, or in water, in the case of volcanic dust and rock-detritus deposited in seas or lakes) it is very difficult to say. In either case we have triturerated rock-matter, in which a banded arrangement of the constituents prevails. It must be admitted, however, that in the rocks of the Malvern Hills the foliation bears but little resemblance to the structure induced by shearing, the crystals and crystalline grains seldom showing any marked lenticular form, while there is but little resemblance, as a rule, to that pseudo-fluxion structure, described by Lehmann* and other observers, which is so characteristic of rocks which have been modified by a creeping movement along structural planes.

My conclusion is, that *the rocks of the Malvern Hills represent part of an old district consisting of plutonic and, possibly, volcanic rocks, associated with tuffs, sedimentary rocks composed mainly or wholly of eruptive materials, and grits and sandstones*. That the structural planes in these rocks, sometimes certainly, at others possibly, indicate planes of stratification, and that the foliation in many cases, if not in all, denotes lamination, due to deposition either in water or on land surfaces, probably more or less accentuated or altered by

* 'Entstehung der altkryst. Schiefer.' Bonn, 1884.

the movements which produced the upheavals, subsidences, and flexures prevalent in the range.

If the progressive development of organisms be admitted, we can scarcely consider that the Trilobites found in the Cambrian rocks represent the earliest forms of life, and, consequently, we may infer that earlier sedimentary deposits have existed in which still lower types would be found. Yet, putting *Eozoon* out of the question, if such fossiliferous deposits exist, where are they, unless so completely metamorphosed that their life-history can no longer be deciphered? This seems an additional reason for supposing that, in the Archæan rocks we have metamorphosed sediments associated with the products of vulcanicity and with plutonic rocks.

The observations embodied in this paper are necessarily very imperfect. To unravel the structure of the Malvern Hills would be the work rather of a lifetime than of a few months. It should also be remembered that the whole Malvern chain is only about eight miles in length and barely three quarters of a mile in breadth in its broadest parts; that it is grass-covered throughout, save where outcrops occur or where quarries have been opened; and that these outcrops and quarries are not sufficiently numerous to enable an observer to work out the relation of the rocks to one another with any precision, except in a few places. It is therefore manifest that it would be unsafe to draw any general conclusions from such scanty data and in so limited an area, except provisionally and with great caution.

APPENDIX TO PART II.

The conclusions arrived at in this paper have necessitated some alteration in the interpretation of the structure of the Malvern Range, as illustrated diagrammatically in the section which was appended to Part I. (facing p. 488).

The prevalence of quartz-syenite or hornblendic granite and the existence of true diorites and hornblendic gabbro indicate that, at all events in a considerable portion of the North Hill, the rocks are certainly eruptive. There seems also reason to believe that much of the mass lying between the Dingle and the summit of the Worcestershire Beacon is also of a syenitic or granitic character, while it is highly probable that the granulite occurring close to the summit represents a marginal condition of the granite. Of the relation of the diorite to the granite and syenite I am uncertain; but it seems probable that the diorite flanks these rocks as at Cock's Tor, Brazen Tor, and other localities in Devonshire, where gabbros and sometimes amphibolites rest on the flanks of the Dartmoor granite*. It is probable also that, in some cases, the diorite penetrates the granitic and syenitic rocks. Upon these considerations I venture to alter that part of the diagrammatic section appended to Part I. which lies between the northern end of the range and the Wych, as in the annexed figure (fig. 4); but it must be remembered that this altered

* "The Eruptive Rocks of Brent Tor," Mem. Geol. Survey, p. 15.

version is still hypothetical, and is not the outcome of any detailed fieldwork.

Fig. 4.—*Hypothetical Section through the North Hill and the Worcestershire Beacon.*

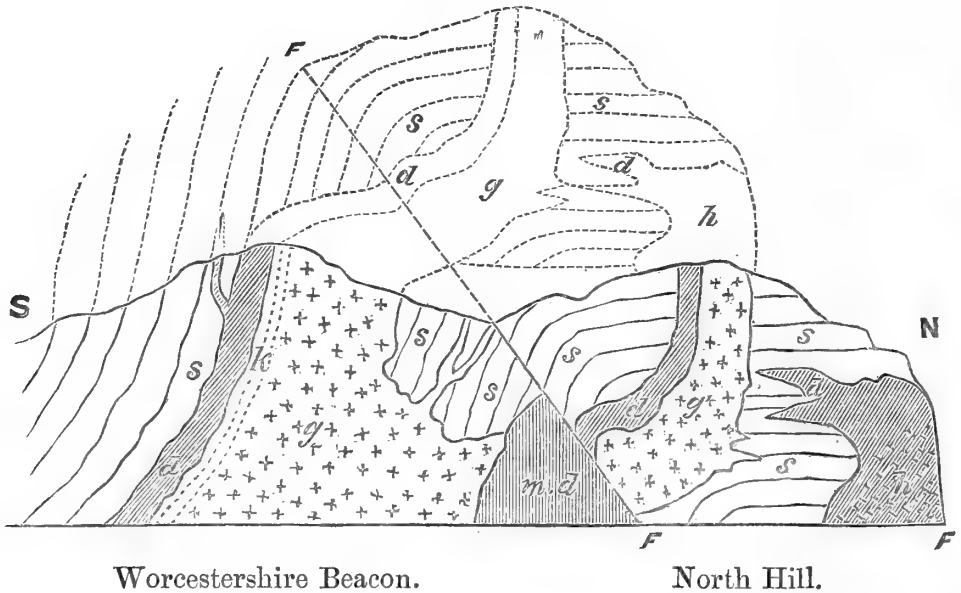

g = Granite. *d* = Diorite. *md* = Mica-diorite. *k* = Granulite. *h* = Hornblende-gabbro. *s* = Gneissic rocks. *FF* = Faults.

The dotted lines indicate the relative positions of the rocks prior to faulting. The rock marked Granite, *g*, is really a very hornblendic Granite or Quartz-syenite.

It may also be desirable to alter that part of the section which lies between the Herefordshire Beacon and the Raggedstone, treating the northern part of Swinyard's Hill as part of a possibly once deep-seated mass of granite or pegmatite faulted in among newer rocks.

The late Dr. Holl was of opinion that this part of Swinyard's Hill was chiefly composed of granitic veins*, and it is quite possible that he may have been right, since he mentioned gneissoid rocks, hornblendic gneiss and schists as occurring with the granite.

His observations in this locality were much more detailed than my own, yet I must admit that this portion of the ridge did not appear to me to consist of veins, and he himself seems to have felt considerable doubt upon this point, as evidenced by the expressions "Granite, probably a vein," "Granite vein?"

The rocks north of this fault crossing Swinyard's Hill and forming the highest part of the ridge appear to be coarse hornblendic granite or quartz-syenite, diorite, and gneiss. The diorites occur on either side of the coarse-grained quartz-syenite, as roughly indicated on the section (fig. 3, facing p. 488), and the contact of similar rocks in the Worcestershire Beacon and North Hill is worthy of note.

The southern part of Midsummer Hill also shows an intrusive or else an interbedded diabase, probably the former.

* *Op. cit.* p. 77.

With these exceptions, I am disposed to let the remainder of the section (appended to Part I.) stand as it is for the present, since it is merely intended to represent diagrammatically what may be, and is based upon a very limited foundation of observed facts.

The foliated finely-crystalline gneiss, micaceous schists, and quartzites in the south of the range appear to represent a series of altered and probably once-stratified rocks, such as sandstones, and micaceous and felspathic grits, and these graduate, as we pass northwards, into gneissic rocks, which probably represent coarse tuffs and detrital deposits, composed almost wholly of materials derived from the waste of plutonic rocks. These are associated with plutonic rocks of similar mineral constitution, probably in some cases of a later date, but still of immense antiquity.

It may also be a point of some significance that in what is here regarded as the Lower gneissic series we have hornblende in great quantity; in the Middle series the rocks become partly micaceous and partly hornblendic; while in the Upper gneissic series, hornblende is almost or totally absent, and the rocks in the lower part of this Upper series are very micaceous. The mica, however, becomes less and less plentiful as we pass southwards, until, in the upper part of this Upper series, it is present either in very small quantity or disappears altogether, as in the quartzites. There is, in fact, as we pass from the north to the south of the Malvern Range, a diminution in the percentage of those minerals which have the greatest density.

Although in this paper it is assumed that the rocks of the Malvern Hills are partly eruptive and partly detrital, the latter showing under the microscope no distinct pseudo-fluxion structure such as would be expected in cases of well-marked pressure-metamorphism, yet it is quite possible that the foliation in some of these rocks may be due to the latter cause.

One of the strongest arguments in favour of such an hypothesis is that foliated or gneissic diorite is here and there found in contact with non-foliated diorite, while gneissic quartz-syenite also occurs in contact with quartz-syenite in which no foliation is discernible.

That the mass which constitutes the main ridge of the Malvern Hills has experienced repeated movements and dislocations coupled with great stresses there can be no doubt. Hence there is strong probability that pressure-metamorphism has had *some* share in developing the minute structural characters of these rocks. Distinct evidence upon this point seems, however, as yet, to be wanting; and therefore, although willing to make all due concession to the advocates of pressure-metamorphism, on the production of sufficient proofs, I am for the present disposed to hold by the opinions which I have already stated, modifying them only to the extent here indicated.

There are probably many exposures of rock, south of the Worcestershire Beacon, which the limited time at my disposal prevented me from visiting, nor am I sure that, among the specimens which I collected, there may not be many which would present fresh points of interest if examined microscopically. In those which have been

so examined there may also be some minerals which I have failed to recognize. Mr. Teall informs me that he has detected sphene in some of the rocks of the North Hill, and I am by no means certain that, in one or two of the sections prepared from specimens collected at the southern end of the range, rutile is not present. The opinions frequently expressed concerning the species of the feldspars must also be accepted, in some cases, with a certain amount of reserve, since the measurement of the extinction-angles was often made from imperfectly developed crystals in which the directions of the planes of section were extremely doubtful.

Under any circumstances the paper does but very imperfect justice to the various points discussed in it, and there still remains in these Archæan rocks a vast and comparatively unexplored field for the exercise of the hammer and the microscope.

EXPLANATION OF THE PLATES.

PLATE XIX.

- Fig. 1. Gneissic quartz-syenite. North Hill. $\times 18$. (Specimen no. 1.)
 2. Epidote-plagioclase rock. Probably an altered diorite-tuff. North Hill. $\times 18$. (Specimen 2.)
 3. Coarsely crystalline and slightly foliated diorite or hornblende gneiss. North Hill. $\times 18$. (Specimen 3.)
 4. Coarsely crystalline quartz-diorite or hornblende-gabbro. $\times 55$. The drawing shows portions of crystals of hornblende and orthoclase. (Specimen 4.)
 5. Diorite. Ivy Scar Rock, North Hill. $\times 25$. (Specimen 7.)
 6. Biotite-gneiss. Quarry above church, West Malvern. $\times 55$. (Specimen 9.)
 7. Altered mica-diorite. Large quarry (Leighton's) at mouth of the Dingle. $\times 18$. (Specimen 10.)
 8. Granulite. Worcestershire Beacon, near top, north side. $\times 55$, polarized light, nicols +. (Specimen 11.)

PLATE XX.

- Fig. 1. Quartz-syenite or hornblende granite (feebly foliated?). Top of North Hill. $\times 25$. (Specimen 6.)
 2. Granite. Worcestershire Beacon, near top, north side. $\times 18$, nicols +. (Specimen 12.)
 3. Diorite? (syenite?) (feldspars much decomposed). Worcestershire Beacon, top. $\times 18$, nicols +. (Specimen 13.)
 4. Diorite. Worcestershire Beacon, top (? dyke). $\times 18$, nicols +. (Specimen 14.)
 5. Epidosite (altered quartz-diorite). Worcestershire Beacon, top, north side. $\times 18$. (Specimen 15.)
 6. Diabase-tuff (? foliation due to pressure-metamorphism). Herefordshire Beacon, north side, near top of ancient British camp. $\times 25$. (Specimen 16.)
 7. Hornblende gneiss. Herefordshire Beacon, north side, near top of ancient British camp. $\times 18$. (Specimen 17.)
 8. Eucrite or anorthite-basalt. Herefordshire Beacon, close to and on west of the cave. $\times 18$. (Specimen 18.)
 9. Basalt. Herefordshire Beacon, east side, at back of the cave. $\times 5$. (Specimen 19.)

- Fig. 10. Diorite. Swinyard's Hill, north side of highest point of ridge. $\times 18$. (Specimen 25.)
11. Biotite-muscovite-gneiss. Swinyard's Hill, largest quarry, south end. $\times 18$. (Specimen 27.)
12. Mica-schist. Raggedstone Hill, east spur, top of north end. $\times 18$. (Specimen 28.)

PLATE XXI.

- Fig. 1. Altered felspathic sandstone. Raggedstone Hill, top, east spur. $\times 25$. nicols +. (Specimen 30.)
2. Quartzite-schist (micaceous). Raggedstone Hill, top, east spur. $\times 25$. (Specimen 31.)
3. Microcline-crystal (crushed and faulted) in granitic vein. Quarry close to and on south-west of the Wych. $\times 35$, nicols +. (Specimen 33.)
- 4 & 5. Corroded and bent crystals of triclinic feldspar in basalt. Herefordshire Beacon, east side, at back of the cave (see also fig. 9, Pl. XX.). $\times 55$, nicols +. (Specimen 19.)
6. Globulitic crystallites in biotite of granite. Worcestershire Beacon, north side, near summit. $\times 850$. (Specimen 12.)
7. Devitrified obsidian, showing perlitic structure and faulted band. Herefordshire Beacon, back of the cave, overlooking Castle Morton Common. $\times 55$. (Specimen 20.)
8. Diagram showing track of spontaneously moving bubble in fluid-lacuna in quartz of gneissic quartz-syenite. North Hill. (Specimen 1.)
9. Group of apatite crystals in diorite. North Hill, just south of Ivy Scar Rock. $\times 350$. (Specimen 7.)

Note.—When not otherwise specified, the figures are represented as viewed by ordinary transmitted light.

DISCUSSION

(December 1, 1886).

The PRESIDENT said that it was satisfactory that the Author had been able so completely to confirm Dr. Holl's work. The three issues raised in the paper would probably meet with a varying amount of acquiescence on the part of the members:—(1) that these rocks are metamorphic, and not igneous, few would contest; (2) there might be a difference of opinion as to the significance of the apparent succession; (3) he anticipated a debate on the relation of foliation to sedimentation.

Prof. BONNEY would abstain at so late an hour from discussing the general question of foliation. Some years ago he had made a collection of these rocks, as also had Mr. Allport, who, he trusted, would yet publish the results of his investigation. He would now only ask:—

(1) Had the Author detected any indications of schistosity along planes of mineral banding?

(2) Is there any strong proof of mechanical disturbance productive of cleavage-foliation?

(3) Lastly, in studying the structure of the more coarsely crystalline rocks, had he come upon those curious structures which occur in the oldest known gneisses, or upon those distinctly characteristic

of igneous rocks, and were they in any way modified by metamorphism?

If these Malvernian rocks are gneisses of true Laurentian types, he would find them exhibit certain modifications in passing upwards.

Mr. TEALL said that the Author had described a number of facts which any theory of the district would have to account for. What is the significance of the principal structural planes? This was the question which must be solved before any advance in the theoretical interpretation of the district could be made. The Author appeared inclined to think that these planes were originally planes of stratification; otherwise no conclusions as to age could be drawn. The coarsely crystalline rocks were igneous rather than sedimentary in aspect. He thought they might be igneous and of plutonic origin.

The PRESIDENT observed that both the great longitudinal fault and also the cross faults were of later date than the foliation.

The AUTHOR, in reply, said that the President had indicated with great clearness the lines which the discussion should take. He agreed with him concerning the age of the faults; the amount of their throw is difficult to determine. Had he known of the intention of Prof. Bonney and Mr. Allport to take up this subject he would have abstained from the task. Not having fully examined his slides, he was unable to answer questions relating to the microscopic characters of the rocks. He had found no particular evidence of mineral reconstruction along divisional planes. Difficult to say whether these rocks were or were not igneous; they are very like some igneous rocks and yet with a rude foliation. He then spoke of the different meanings attached to the word metamorphism. Judging from hand specimens, the Malvern rocks seemed to resemble those from the Hebrides and Canada. He had little doubt that the fine-grained schists were sedimentary, as they even contained beds of quartzite. He admitted that, according to the meaning given to the section, the great planes must be taken as bedding-planes. If the rocks were igneous, then the divisions into upper, middle, and lower groups had but little meaning. There may have been interbedded lava-flows. He had never met with divisional planes of such an even and persistent character in undoubted plutonic rocks. The divisional planes, rudely parallel to the surfaces of granitic masses, such as those described by Boase and De la Beche, were far less regular.

DISCUSSION

(April 6, 1887*).

The PRESIDENT observed that the Society did not often enjoy the advantage which they had that evening, of hearing papers on the same locality by two authors who looked at the subject from different points of view.

* This Discussion relates also to Dr. Callaway's papers on the Rocks of Galway and the Malvern Hills, pp. 517 and 525.

Mr. TEALL said that Mr. Rutley had described a number of important facts, but was very guarded in his interpretation of them. Dr. Callaway offered solutions of many of the problems. The passage from felsite into a variety of mica-schist was of great interest. He agreed with Dr. Callaway, that crystalline schists and massive igneous rocks of similar chemical composition are frequently found in association with each other. He also agreed with Dr. Callaway as to the origin of certain banded gneisses. Granitic and dioritic rocks might be seen in one part of the Lizard to vein each other in the most intricate manner. It was possible to trace the veined series into a banded gneissic series without a break. He regarded the banded gneissic series as the result of the deformation of a complex mass of plutonic igneous rock, and this was the view he understood Dr. Callaway to maintain with reference to some of the Malvern gneisses.

Dr. HICKS said that the two views were nearer than would appear. Each admitted that there was a granitoid rock in the centre, with dioritic rocks on the flanks, both igneous. To a certain extent these conditions are similar to what is found in some parts of Scotland, where, associated with granitoid rocks, there is a series of schists and gneiss. He was disposed to incline towards Mr. Rutley's view, that there is a series of some kind, probably as in the Peibidian—a volcanic series—where pressure had produced schistosity in parts even of the intrusive rocks, but not in the great masses. Dr. Callaway speaks of a felsitic rock converted into mica-schist; from this view he was inclined to differ, as some of the specimens exhibited as converted into mica-schists should be classed rather as schistose felsites, as the felsitic structure is not destroyed, and the mica occurs as a secondary product along the cleavage-planes, mainly as the result of infiltration. The Archæan rocks may be, in the main, of igneous origin, but they contain also detrital and chemical deposits.

Col. McMAHON asked Dr. Callaway whether the foliation of a certain mass shown on one of the diagrams had been produced by intrusion, by pressure previous to consolidation, or by pressure subsequent to consolidation, and, if subsequent, how he accounted for the granite showing no foliation at all.

Dr. CALLAWAY expressed himself unable to explain Mr. Rutley's diagrams, and

Mr. RUTLEY stated that the section through the North Hill was hypothetical.

The PRESIDENT commented on the different inferences drawn from the same set of facts. In the North Hill there are rocks not foliated and others greatly foliated. To Mr. Rutley this afforded the strongest proof of difference of origin, whilst Dr. Callaway saw gradual transitions from one to the other. The attempt to explain the formation of schists from volcanic rocks of an acid character had not been made before in this country.

Mr. RUTLEY, in reply, was at a loss to recognize the position of Dr. Callaway's section. He remarked that the foliation in these

rocks appears to be restricted to bands. He referred to a diagram in a recent publication by Mr. Mellard Reade, which proves that flexure cannot take place without great trituration of the intervening mass, and he considered that such a cause had produced a certain amount of foliation. He commented on the opposite views expressed by Drs. Hicks and Callaway with reference to the alleged conversion of felsitic rocks into mica-schists. A case parallel to one of the instances of foliation mentioned by Dr. Callaway may be met with on the west of Dartmoor.

Dr. CALLAWAY, in reply, congratulated himself on having had the support of Mr. Teall. Replying to Dr. Hicks's remarks, he held that there was a true passage between felsite and mica-schist; but this was a matter of field-observation, and could not be decided in that room. He did not see how a succession could be made out of hypogene igneous rocks. How the localization of pressure was effected he could not tell. There is a foliation, whether local or general. The section queried by Mr. Rutley is half a mile north of the Wych.



1 / 18

3 / 18

5 / 25

7 / 18

ROCKS FROM [unclear] [unclear] [unclear] [unclear]

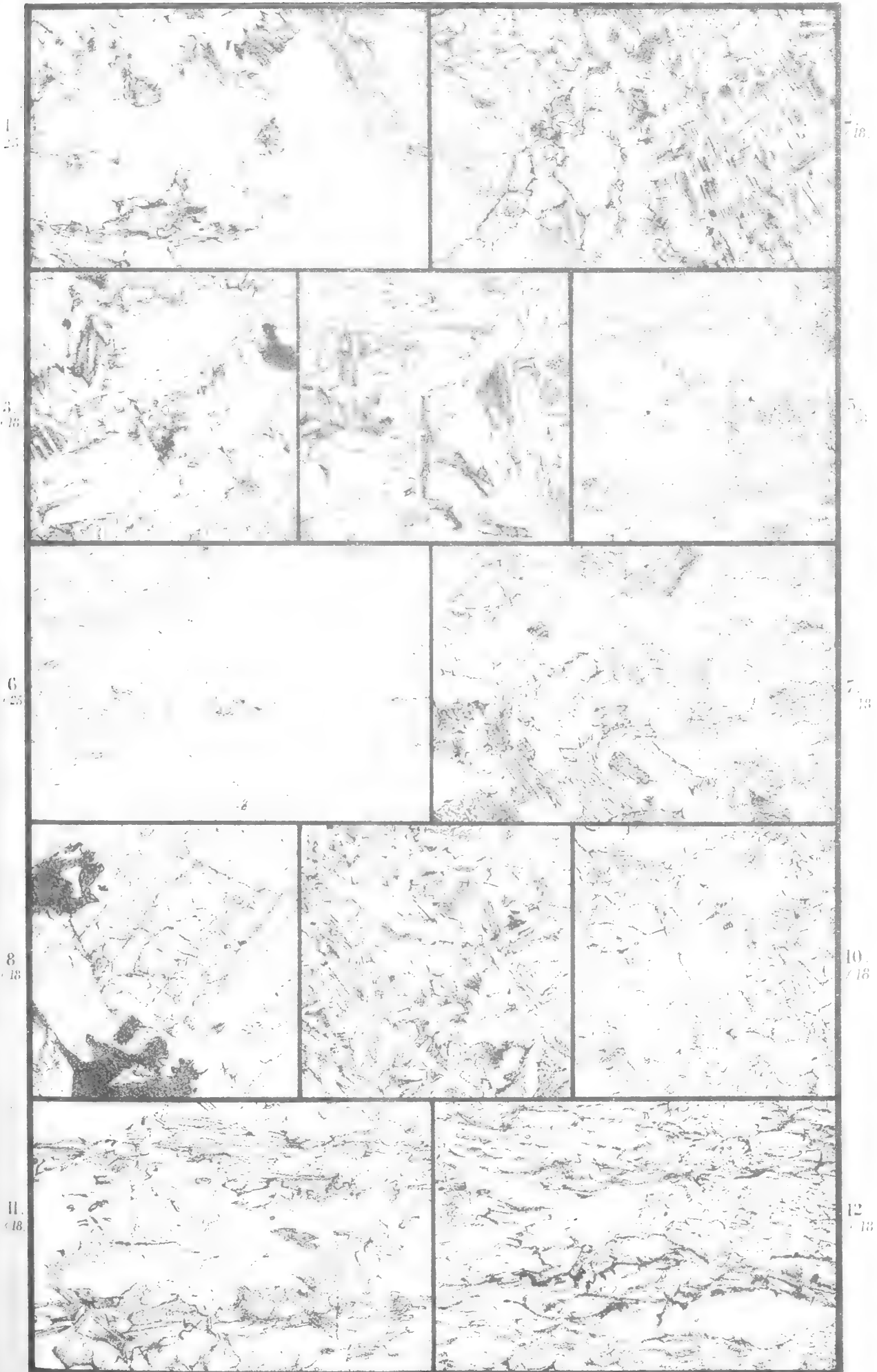

Frank R. ...

9. 25

Mintern Bros ...

ROCKS OF THE MALVERN RANGE.



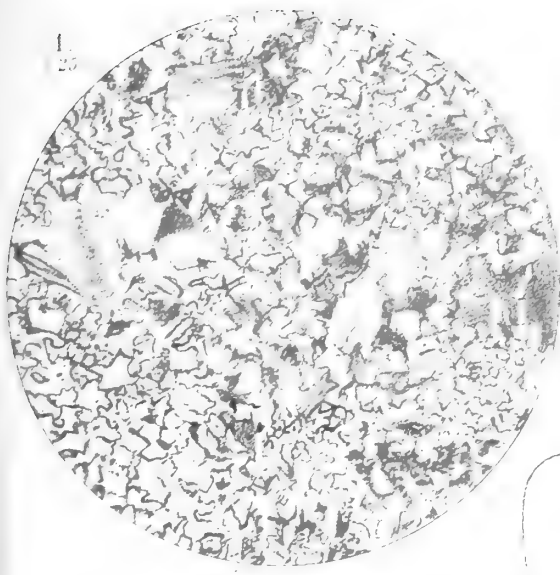

1

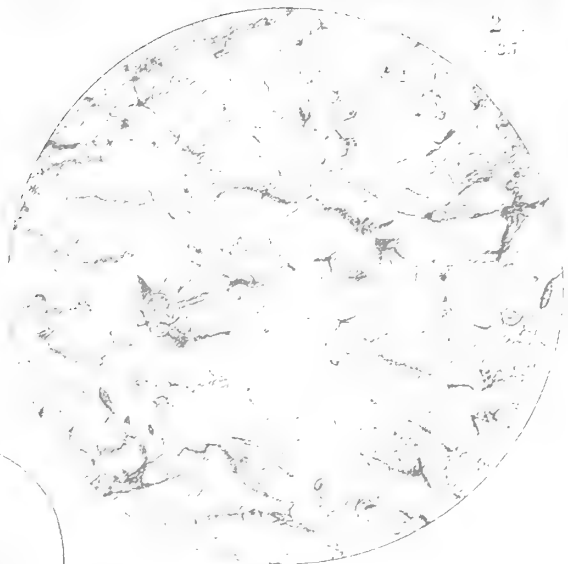

2



3



4

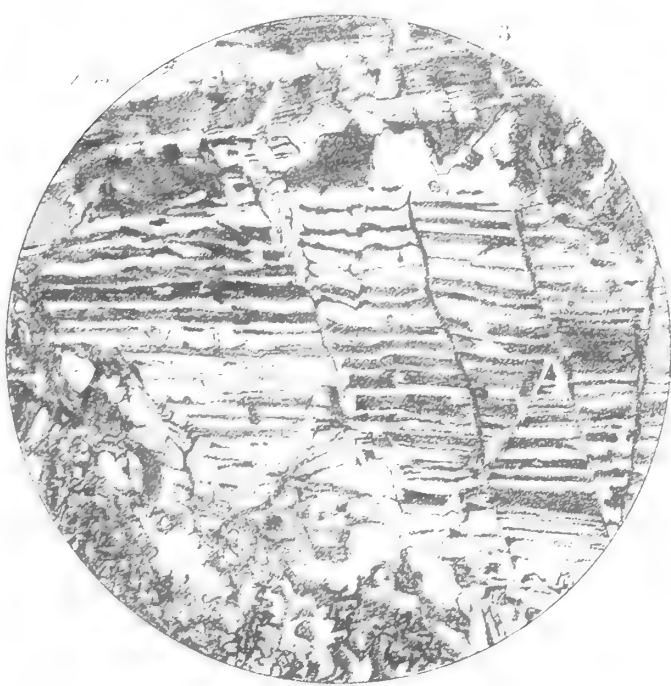

5



6



7



9

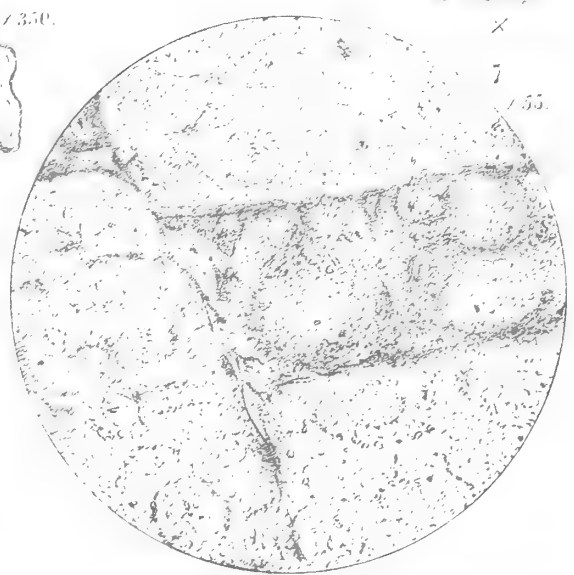

8

Frank Pusey del.

Museum Press

ROCKS OF THE MALVERN RANGE.

36. *On the ALLEGED CONVERSION of CRYSTALLINE SCHISTS into IGNEOUS ROCKS in COUNTY GALWAY.* By C. CALLAWAY, Esq., D.Sc., F.G.S. (Read April 6, 1887.)

INTRODUCTION.

1. General Distribution of the Igneous Rocks.
2. The Relations of the Igneous Rocks to each other and to the Schists.
Knockseefin, Ground south-east of Glendalough, Lettershinna,
Ground south of Glendalough.
3. The Foliation of the Igneous Rocks.
The Granite. The Diorite. Veins of an Acidic Rock.
4. Age of the Igneous Rocks.
5. The Galway Gneiss.
6. Summary.

INTRODUCTION.

THE theory of the metamorphism of aqueous deposits into granite and other igneous rocks has been maintained by most Irish geologists, and is set forth with much detail in the elaborate memoirs of the Irish Geological Survey * on the district between Galway and Westport. It therefore seemed to me, after some preliminary work in Donegal †, that the Connemara region would probably afford rich material for the determination of the question. In this hope I was not disappointed; but while working at the relations between the igneous and the metamorphic rocks, another problem, the origin of the schists themselves, began to emerge. The result of my inquiries was a singular reversal of the theory I was examining. I found, not that the igneous rocks had been formed out of schists, but that some, at least, of the schists had been formed out of igneous rocks. The Galway region has, indeed, been most fruitful in suggestion, and has supplied me with a clue to the origin of some of the less complex gneisses.

I have to acknowledge my obligations to Prof. Bonney, F.R.S., who has been kind enough to look through my microscopic slides, and to give me his opinion on critical points.

In discussing the origin of the igneous rocks, it will be desirable to state briefly the evidence upon which the theory of the Irish Survey has been based. I will give the chief points, as far as possible, in the words of the Survey Memoirs ‡.

Of the granite there are three types—Intrusive, Porphyritic, and Foliated. The porphyritic passes into the porphyritic-foliated, and the latter sometimes gradually loses its porphyritic character, and seems to pass into gneiss and schists. It is inferred as probable that the foliation of the granite points to its original stratification and that even the porphyritic granite was originally part of a sedimentary series; but being nearest to the “seat of metamorphic action,” “all

* To accompany sheets 93, 94, 95, 104, 105, 113, 114.

† Quart. Journ. Geol. Soc. vol. xli. p. 221.

‡ Memoirs 105 and 114, pp. 7–16 *et alibi*.

or nearly all traces of foliation which succeeded the stratification " had been obliterated.

In the "metamorphic sedimentary rocks" are "conglomeritic beds," "containing large and small blocks, sometimes sparingly scattered through the mass, but often thickly together." When the blocks are scattered they are considered to be due to a nodular structure in the original rock; but when numerous, the rock is regarded as "metamorphosed conglomerate."

Of the numerous varieties of igneous rocks described in the Survey Memoirs, I shall usually be able to confine myself to two, granite and diorite. The granite is either uniform in grain or porphyritic, and either kind may be foliated. The diorite is generally a dark-green coarsely crystalline rock without varietal differences of importance. For the purposes of this paper, it will be unnecessary to notice minute distinctions.

1. GENERAL DISTRIBUTION OF THE IGNEOUS ROCKS.

The granite forms an extensive area reaching from the town of Galway all along the northern side of Galway Bay to the open Atlantic, and broadening out towards the west to a width of nearly 20 miles. It also appears in irregular intrusions amongst the schistose rocks to the north of the main mass. The most prominent exposures of the diorite are dotted at intervals round the northerly margin of the chief granite mass, either at a little distance from it or in actual contact with it.

2. THE RELATIONS OF THE IGNEOUS ROCKS TO EACH OTHER AND TO THE SCHISTS.

Knockseefin.

This hill lies nearly 4 miles to the south of Oughterard, and close to the margin of the chief granite-mass of the region. This is stated* to be the typical locality for witnessing the passage of granite into schist.

The ground is covered between the granite and the gneiss of which the hill is chiefly composed. The latter rock is a mica-gneiss of coarse grain, but clearly banded, weathering on strike-surfaces in fine parallel raised lines. The foliation-planes strike to the N.W. Towards the summit, nodules of diorite, lenticular in horizontal section, made their appearance in the gneiss, their longer axes running with the strike. These are apparently the extremities of veins which have been flattened by pressure.

The diorite-nodules (veins) increase in number towards the top of the peak, and at the very summit the rock is nearly all diorite. Granite here comes in, irregularly penetrating the diorite. The latter displays a sort of nodular jointing, the joint-blocks running in a roughly linear manner to the N.W., while the granite in

* Kinahan's 'Geology of Ireland,' p. 190.

places finds its way along the joints, forming a cementing matrix. The mixed rocks thus present a superficial resemblance to a conglomerate. It appears from this section that the diorite is intrusive in the gneiss, and the granite in the diorite. It would also seem as if the diorite had consolidated and acquired a jointed structure previous to the introduction of the granite. How this ground affords evidence of a passage from granite into schist, I am unable to understand.

Ground south-east of Glendalough.

The singular phenomena I am about to describe occur at the eastern end of a long band of "hornblende-rock," which runs in an east and west direction for a mile and a half. We here see all the steps of the process by which igneous rocks have been converted into a pseudo-conglomerate.

The prevailing rock is diorite, with a very distinct jointing. On the weathered surfaces the material along the joints has yielded to degrading influences, so that the blocks between stand out in relief. These joint-blocks have a diameter varying between a few inches and perhaps two feet. In shape they are sometimes roughly oval or ovate, but frequently they are partially angular or subangular. Some of them are represented in figs. 1-3.

There are in this locality several outcropping masses, some of which consist of unbroken diorite. In others, the following appearance is observed. For some yards, we pass the jointed diorite; then we see a gradual coming in of the granite. Thin veins find their way along the joints, in one place coming to an end against a joint-block (fig. 1), and in another, where the joints narrow, termi-

Fig. 1.—*Section of Granite in Jointed Diorite.*

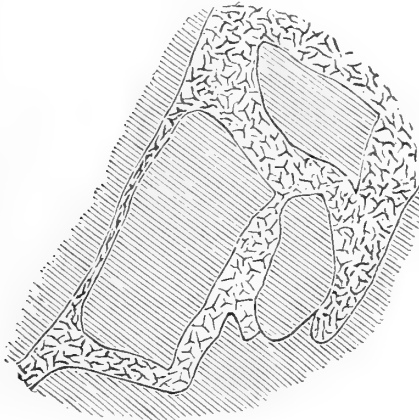

nating between adjacent blocks. Not far off we see veins creeping along each side of a block, but failing to force their way entirely round (fig. 2); while close at hand the granite has succeeded in entirely isolating the blocks from the main mass, so that diorite is immersed in granite. It is therefore clear that these pseudo-conglomerates are merely agglomerations of joint-blocks imbedded in a

ground-mass of granite. For these mixtures of hypogene rocks, the term "diglomerate"* may be suggested.

Fig. 2.—*Section of Granite in jointed Diorite.*

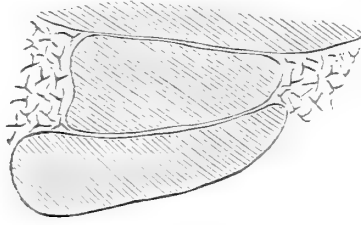

Lettershinna.

Some interesting facts in confirmation and expansion of the preceding observations occur in this hill, which lies two and a half miles south-west of the last locality, and therefore much nearer the granite *massif*. Lettershinna is a ridge running east and west in accordance with the strike of the region. It is mainly composed of granite; but near and at the summit are some masses and blocks of included diorite.

On the north-western slope, I observed an oblong block of diorite immersed in the granite. The fragment was about a yard long and eighteen inches broad (fig. 3). The microscope shows the

Fig. 3.—*Section of Diorite in foliated Granite.*

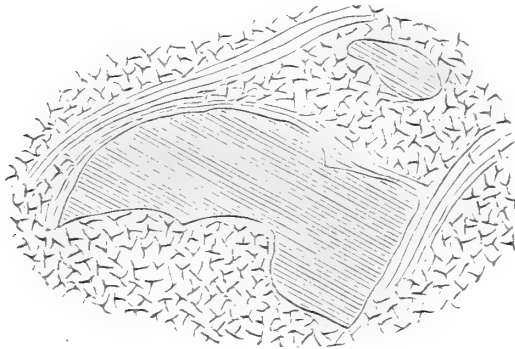

hornblende of this diorite to be clear and well crystallized; but the felspar is cloudy, and has apparently undergone partial decomposition. At the distance of about a foot was a smaller block of a roughly ovoid shape. That these are true inclusions, and not cross sections of veins, may be seen a little higher up the hill. Here a block of diorite is exposed in the face of a cliff, the foliation of the granite curving round the block both above and below it.

Near the summit of the hill the diorite occurs in larger masses. Some of these are fringed by one or more outlying bands arranged roughly parallel to the margin. In one place there were three of

* "di-," because the blocks are forced asunder.

these (fig. 4); in another, only one. Sometimes they are mere flakes. They are isolated from the main masses and from each other by granite. It would appear as if they were separated from the parent blocks by exfoliation. As the granite rose up between the blocks,

Fig. 4.—*Section of Diorite (? exfoliated) in Granite.*

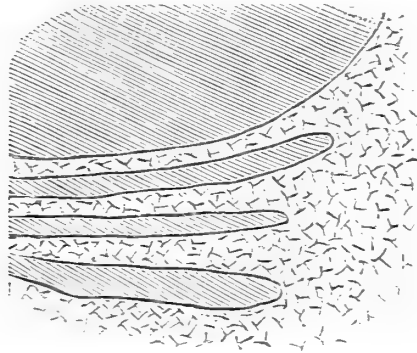

they would become strongly heated, and the outer zones, being hottest, would by their greater expansion split away concentrically. That the exfoliated fragments retain their parallelism to the adjacent margin of the main masses is a remarkable fact, to which I shall return.

Ground south of Glendalough.

Leaving the hotel in a southerly direction, we pass over crystalline limestone, quartzite, and a considerable thickness of hornblende-schist. A little further south lies a large mass of rock, chiefly hornblendic, which is said to “graduate into the associated gneiss and schist”*. Near where “Σ” is marked on the map, there is a singular entanglement of schist with granite and diorite. The rocks are heavily glaciated, so that it was impossible to obtain large specimens; but even the small fragments collected clearly show that there is no passage between the schists and the igneous rocks. The schists are intensely contorted and much shattered, and the granite or the diorite sometimes finds its way even between adjacent folia, and is mixed up with the schists in inextricable confusion. Several contact-specimens have been microscopically examined, and Prof. Bonney, at my request, has devoted special attention to them. He thinks there is no doubt that they are a case of intrusion of granite into a fibrolite-schist; but the structure of the granite is irregular and peculiar, owing probably to its contact with the schist.

It is a striking fact that, in this locality, detached folia, or bundles of folia, frequently preserve an approximate parallelism to the foliation of the adjacent schists. This might appear to be a strong piece of evidence in favour of the metamorphic hypothesis. It is not easy to believe that an igneous rock could have been intruded amongst masses and fragments of schist without destroying the parallelism of strike. I would, however, venture to urge that the

* Survey Memoir, 93, 94, p. 139.

facts furnished by the Lettershinna sections greatly attenuate the difficulty. If I am right in my reading of those sections, it is clear that the granite has intruded between the strips of diorite and pushed them apart, without materially disturbing their parallelism.

But if we reflect upon the probable conditions under which the granite was intruded, even the original difficulty will not appear so great. The displacing power of an intruding current of molten matter will be in proportion to the rapidity of its motion. Dykes of greenstone intruded into faults often contain numerous pieces of fractured rock lying pellmell. But an igneous rock forced along lines of least resistance by tangential pressure may be expected to move with extreme slowness, so that the currents might act rather in the manner of slowly moving wedges than with the irregularity of an ordinary flow.

Another consideration appears to me of still greater weight. The region under discussion has been subjected to great pressure. If, then, a number of flattened pieces of schist were scattered pellmell through the plastic mass of granite, the compressing force would move the fragments into planes lying at right angles to its own direction. We are familiar with a similar result in the formation of slates, and we may safely infer that the process would be facilitated by the plasticity of the granite.

3. THE FOLIATION OF THE IGNEOUS ROCKS.

The Foliation of the Granite.

The foliated structure is well seen in the district south of Glendalough. In one spot, the granite runs into the diorite in long tongues striking east and west, that is, in coincidence with the strike of the schists in this area, and here the foliation of the granite is also east and west, and is strongly marked. But where the veins were oblique to the strike of the region, the foliation was oblique and obscure. In another place, where the veins ran north and south, they were intensely contorted. These facts point clearly to the influence of an earth-thrust acting along a north and south line.

Foliation in the Diorite.

I noticed this on Knockseefin, in veins intrusive in schist. The foliated structure is parallel to the longer axes of the transverse sections of the veins and to the strike of the schists. It is obviously due to pressure. Prof. Bonney has examined slides of this squeezed diorite, and he finds no difference between it and hornblende-schist.

Foliation in Veins of an Acidic Rock.

Near the summit of Shannarea appear several veins, lenticular in plan, which are not easy to explain. They consist of quartz, with a little mica, probably biotite, and a fair number of garnets. The foliation is very distinct, and coincides with the foliation of the

enclosing schists. Most of the mica is in long, narrow, ragged flakes, almost like bits of frayed string, and suggests great compression. The rock is now a sort of quartz-schist. What it was originally, it is hard to say; but I see no reason why it may not have been a hornblendic granite, like the granite of the district.

4. AGE OF THE IGNEOUS ROCKS.

The Silurian conglomerates of Killary Harbour are mainly composed of large rounded fragments of igneous and metamorphic rocks. Amongst these is a coarse-grained granite, with a great deal of plagioclase and a little altered biotite. The constituents of this rock are the same as those of the typical Galway granite, but the feldspars are smaller. Pebbles of quartz-felsite are also abundant. The ground-mass of this felsite is devitrified, the quartz-crystals are large and clear, and there is a small proportion of biotite. This description will also apply generally to the ordinary quartz-felsite near Galway. The conglomerates clearly prove that in early Silurian times the adjoining land largely consisted of igneous rocks, closely resembling those still found in the region, and we may therefore fairly conclude that the granite and felsite, with the still older diorite, are of Pre-Silurian age. The metamorphic schists enclosing the intrusive masses and veins are, of course, of still greater antiquity.

5. THE GALWAY GNEISS.

This rock forms a triangular area about two miles each way, with the town of Galway situated in the centre. It is bounded on the west by granite and felsite, on the north-east by the Carboniferous limestone, and on the south by Galway Bay. It is usually coarsely crystalline. The common minerals are quartz, feldspar, and hornblende, with epidote as accessory. The quartz and feldspar form the ground-mass. Immersed in it are numerous dark, speckled blocks, suggesting the diorite fragments in the granite further west. These block-like masses are often arranged in a roughly linear manner, but frequently they are irregularly distributed. Hornblende also occurs in bands or masses, displaying a foliated structure. In the latter case, the rock is like true gneiss. Rarely could I find continuous seams of the hornblende. A flaky appearance sometimes occurs on rather a large scale, long slender tongues running out irregularly from patches of foliated hornblende into the grey granitoid ground-mass.

There is no true bedding in the Galway gneiss, so far as I saw; but the seams and masses of hornblendic rock usually lay with their longer axes dipping at a high angle to the N.N.W. Comparing this gneiss with the conglomerates already described, a similarity of origin is at once suggested, the apparent dip being accounted for by tangential pressure. As this was the first district I visited in Connaught, the significance of the phenomena did not then appear, and my work proceeded on other lines; but the hints afforded by the

behaviour of the igneous rocks of the region further west have since been worked out in the Malvern Hills, as will appear in a separate communication.

6. SUMMARY.

1. There is no satisfactory evidence for the contention that the igneous rocks of Western Connaught have resulted from the metamorphism of schists, since in every locality examined, including the type section, the igneous rocks were seen to be sharply separable from the schists and clearly intrusive in them.

2. The "metamorphosed conglomerates" adduced in proof of the original sedimentary character of the Galway schists are mixtures of schist, diorite, and granite, or of two of them, the ground-mass being usually granite.

3. There is no proof that the foliation of the igneous rocks follows an original structure. In the granite it is chiefly due to regional pressure. Fragments of diorite in granite are not foliated, but veins of diorite in schist sometimes display a foliation caused by pressure.

4. The ancient gneissic rocks of Galway town display evidence of having been formed in part from mixtures of diorite and granite, similar to the more modern diglomerates.

(For the DISCUSSION on this paper, see p. 514.)

37. A PRELIMINARY INQUIRY *into the GENESIS of the CRYSTALLINE SCHISTS of the MALVERN HILLS.* By CH. CALLAWAY, Esq., D.Sc., F.G.S. (Read April 6, 1887.)

Introduction.

1. The Materials from which the Schists were produced.
Diorites, Several Varieties; Granite; Felsite.
2. Evidence of Pressure.
Contortion of Granite-veins.
3. The Products of the Metamorphism.
 - A. Simple Schists.
Hornblende-gneiss, Mica-gneiss, Mica-schists.
 - B. Injection-Schists.
Duplex Diorite-gneiss, Granite-diorite-gneiss.
4. General Remarks.
5. Summary.

INTRODUCTION.

THE igneous origin of some foliated rocks was first suggested to me by the granite of Northern Donegal*. The Rev. E. Hill, F.G.S., had previously noticed † a gneissic structure in the granite of Guernsey. Mr. J. J. Harris Teall, F.G.S., has described foliation in basic rocks in the North-western Highlands ‡ and at the Lizard§. Schistosity in granitoid rocks has also been observed in the Alps by Professor Bonney ||, F.R.S. Besides English workers, several foreign writers, both American and Continental, have declared in favour of an igneous origin for certain schists, so that the production of a parallel structure in igneous rocks may fairly be regarded as an established fact.

The work which I have described in another paper (p. 517) led me to hope that we might be able to advance a step further. The intrusion of veins of granite in diorite, under pressure, suggested that at great depths, where pressures were at a maximum and chemical processes might be presumed to be most active, gneissic rocks of a more varied character might be produced. At the town of Galway I had seen gneisses which might have been produced in this way; but the crystalline schists of the Malvern Hills have furnished clear evidence of the genesis of some of the more complex gneisses, besides throwing additional light upon the production of the simpler schists. I am able to show that many of the schistose rocks of Malvern have an igneous origin, and I hope that the clues I have obtained will enable me in a future communication to extend my explanations to certain varieties whose genesis is at present less clearly ascertained.

* Quart. Journ. Geol. Soc. vol. xli. p. 221.

† *Ibid.* vol. xl. p. 404.

‡ *Ibid.* vol. xli. p. 133.

§ Geol. Mag., Nov. 1886, p. 481.

|| Quart. Journ. Geol. Soc. Pres. Address, 1886.

1. THE MATERIALS FROM WHICH THE SCHISTS WERE PRODUCED.

Diorites.

I have been able to recognize at least four varieties of diorite in the schists thus formed.

Medium-black (No. 1).—This rock contains about equal proportions of hornblende and felspar, and in the mass appears nearly black. The felspar, under the microscope, often presents a cloudy appearance, and contains numerous clear microliths, both conditions indicating alteration. When the alteration is only slight, the twinning of plagioclase is visible, but this occurs only in a minority of the crystals.

Coarse-black (No. 2).—The hornblende is often in a greater proportion than in No. 1. The crystals of both minerals are larger. The felspars display similar alteration.

Coarse-grey (No. 3).—The hornblende is usually about one fourth of the mass. Most of the felspar is less changed, and shows the striping of plagioclase.

Medium-grey (No. 4).—The hornblende is abundant, but pale in colour. The felspars display no twinning, are cloudy, with large patches of opacite in the centre, and frequently contain microliths. This variety will be but slightly referred to in the present paper.

I am not prepared to say that none of these varieties ever graduate into each other, but I have seen no evidence of a passage in any case. No. 4 is the newest, for veins of it occur in No. 3; and No. 3 is probably newer than Nos. 1 and 2, since at North Malvern it contains rounded and angular fragments of both. The occurrence of these fragments would seem to indicate a consolidation previous to the intrusion of the younger variety, and this is confirmed by sections in the quarries at North Malvern. A mass of No. 2 was seen to be penetrated by a variety of a lighter colour. The vein passed between irregularly shaped joint-blocks, and contained detached pieces of the darker kind. In another mass, a fine-grained diorite was intrusive in a coarser variety, and in like manner enclosed large blocks of the older rock. In this respect the mode of intrusion is similar to that of the granite in diorite, as described in my paper on the rocks of Galway. I have noticed, however, that in Malvern, as well as the town of Galway, there was a more thorough welding together of the two kinds of rock at their junctions than was observable in the Pre-Silurian granite and diorite of Connemara.

Granite.

I have no positive evidence of the existence of more than one variety of original granite in the Malvern Hills. This is the well-known binary compound of quartz and red orthoclase.

This granite is younger than all the above-named diorites. By its association with them it gives rise to some of the most interesting phenomena of the region.

Felsite.

Near the Wind's Point, there is a well-marked band of felsite hading in accordance with the banding of the enclosing gneiss. It is compact, homogeneous, and of a pale-reddish colour. A similar rock occurs in the Raggedstone Hill, and by its modification gives rise to schists.

2. EVIDENCE OF PRESSURE.

Zones of crushing, indicated by bands of breccia, are very common in the district; but some of these are posterior to the metamorphism and do not concern us. Some direct evidence of mechanical force, resulting in schistosity, will come out in describing the intimate structure of certain rocks; but it is obviously difficult to obtain very abundant indications amongst igneous masses, where there are no beds to be contorted and faulted. There is reason to believe that the pressure is partly transformed into molecular energy, and thus changes are brought about which often mask mechanical effects. There is, however, some field-evidence for the action of enormous pressures. A good example is seen in a quarry of gneiss at the southern termination of Key's End Hill. The foliation-dip is at a moderate angle to the south-east. The rock is traversed by contorted veins of granite, running in several directions. One of these is shown in fig. 1, and gives a rough measure of the pressure.

Fig. 1.—*Contorted Granite-vein in Gneiss.*

S.W.

N.E.

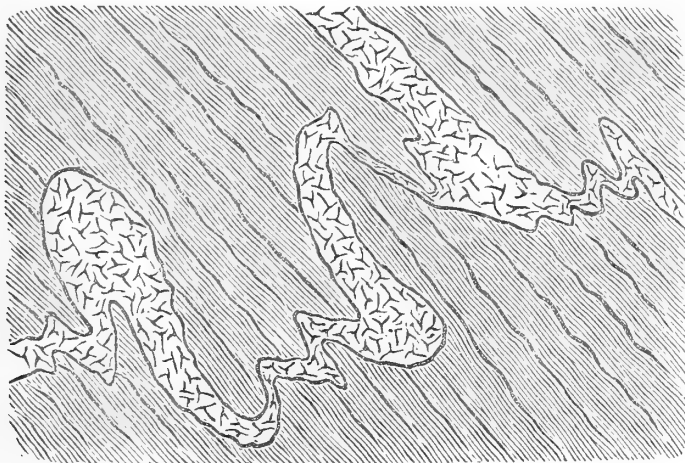

Assuming the vein originally to have been straight, its length has been reduced in the proportion of about five to two.

The regional pressure has acted with intensity only at intervals along the range. In the North Hill and the northern part of the Worcestershire Beacon there are large masses of diorite which have undergone little mechanical change; but between the summit of the Beacon and the Wych there are numerous alternations of diorite and granite displaying foliation. The long ridge between the Wych and the Wind's Point contains a great deal of black diorite

with granite-veins; but at intervals, and especially at the southern end, a banded structure has been produced. The northern part of Swinyard's Hill is composed of massive granite, while at the southern end is a flaggy gneiss, which has been produced from the granite by pressure. Other examples of the localization of pressure occur in the hills further south.

3. THE PRODUCTS OF THE METAMORPHISM.

A. *Simple Schists, or those formed from one kind of rock.*

Hornblende-gneiss, formed from Diorite.—In this case the pressure has rearranged the constituent minerals, so that the hornblende and felspar lie in irregular folia. There are many gradations between the ordinary diorite and a gneiss in which there has been some reconstitution of the minerals, the formation of quartz being the most conspicuous result. The coarse-black diorite, at North Malvern, is one variety which has been modified into gneiss. For about two thirds of the breadth, the intrusion of the vein was clearly seen; then, for a few inches, the two kinds of diorite were confusedly mingled. The remainder of the breadth, consisting only of the coarser diorite, was rudely foliated.

Mica-gneiss, formed from Granite.—Near the southern end of Swinyard's Hill, on the crest of the ridge, is a very interesting case of the formation of gneiss by crushing. A narrow band, striking across the axis, has the appearance of the ordinary binary granite; but a laminated structure is very apparent even in the field. In immediate contact, forming part of the same mass, the rock is flaggy, and seams of mica appear. Then comes a break, but flaggy schists of the same general type appear in force a few hundred yards to the north. A description of microscopic slides will bring out the transition indicated.

No. 281. This was taken as a typical specimen of the granite which is seen in mass at the northern part of the hill. It is the ordinary compound of orthoclase and quartz, with a little mica. Most of the felspar is suffused with a brownish tinge, probably iron-oxide, and presents a cloudy appearance. Many of the crystals also contain patches or microliths of clear mica, polarizing in brilliant colours. The felspar has therefore undergone partial decomposition. That this granite contains iron would appear from the analysis of the Rev. J. H. Timins*. He states that the "quartzo-felspathic" veins, which are almost certainly the granite I am discussing, furnished in three analyses iron-oxide varying between .92 and 1.52 per cent. Both quartz and felspar are somewhat cracked, and iron-oxide is deposited in the cracks.

Nos. 282-284.—From the locality at the southern end of the hill.

No. 282. From a part of the laminated granite which appears more granitoid than the rest. The rock is excessively cracked and crushed, the cracks, which run in all directions, but predominantly

* Quart. Journ. Geol. Soc. vol. xxiii. p. 362.

with the parallel structure, being filled with either iron-oxide or mica. The quartz lies in wedges rather than folia. They are approximately parallel, roughly lenticular in section, and rarely continuous across the slide. Sometimes lines of quartz-grains curve round the feldspars. In one part of the field an angular bit of quartz is immersed in a confused mass of quartz and feldspar in granules. The parallelism of the quartz seems at some points to be determined by cracks, which are occupied by infiltrated products.

The feldspar has the brown cloudiness of the uncrushed granite. It is very much cracked, and where crystals are defined they are rather flattened, and often tail out to a point on each side, so as to resemble a human eye in shape. Some of the feldspar, forming bands of small crystalline grains between the quartz folia, is very dirty.

Mica is very small in quantity. It occurs in some of the narrow cracks in quartz, and in some of the feldspar, and rarely it forms a sort of sheath to the attenuated ends of the eye-shaped crystals.

No. 283. From the same piece as the last, within a few inches of it, but showing such clear lamination that it caught my eye at a distance. Under the microscope it is much more like a gneiss. The field is clearer, and there is much less cracking of the minerals. The folia of quartz are longer, thinner, and more uniform in thickness. In a few parts the quartz is traversed by longitudinal cracks, but their mode of origin is less evident. Most of the feldspar is in regular folia of small crystalline grains, but there still remain a few of the larger feldspars with rounded and irregular outlines. Some distinct folia of mica now make their appearance amongst the feldspar, but the quantity is still small. There has evidently been much reconstruction of the minerals in this slide.

No. 284. Part of the same block, but with the flaggy structure, and showing in the field dark seams of mica. The quartz-folia are still longer than in No. 283 and more regular in thickness. In some spots a thin folium bends out of its course round a crystal of feldspar. The feldspar is similar to the last. Seams of small granules of this mineral also are seen to curve out of the straight line round large crystals. The notable difference between this and all the preceding slides is in the much greater proportion of mica. It often occurs in regular folia between the quartz. Sometimes it forms a complete sheath to an eye-shaped feldspar-crystal. In one place a feldspar has been cracked obliquely across, and the crack is filled in with mica. Thus each half of the crystal forms an almond-shaped "eye," with its fringe of mica. There can be no question that this mica, which is the same in all the set of slides, has been formed out of the feldspar.

No. 285. From the flaggy schists to the north of the last. The structure of the rock strongly suggests a similar origin. There is more quartz, which here and there looks as if the lines separating its folia had originally been cracks. Several cracks also cut across the foliation, and these are filled in with mineral matter, which in one spot is seen to be optically continuous with a regular folium. At another point an elongated granule of quartz, forming part of

a folium, passes across a transverse crack which therefore must be older than the folium, and presumably older than the general foliation in its completed state. Where a transverse crack passes through quartz, it sometimes vanishes for a little distance, reappearing further on, so that it is clear that the sides of the crack have come together and become welded. The occurrence of these transverse cracks, and their evident connexion with the process of metamorphism, is a piece of evidence which tends strongly to confirm the suggestions made by the structure of the folia.

Mica-schist, formed from Felsite.—A very interesting section (fig. 2), about 30 feet in length, is seen in the slope at the end of the

Fig. 2.—*Passage of Felsite into Schist.*

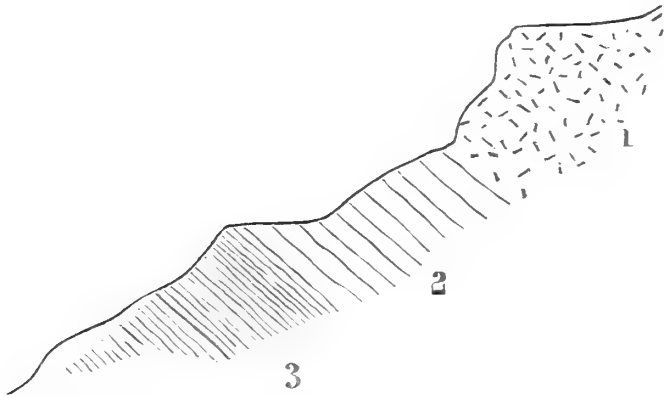

1. Crushed Felsite. 2. Schistose Felsite. 3. Schists.

south-eastern spur of the Raggedstone Hill. Taken in descending order, the following are the rocks observed:—

1. Pale-reddish felsite, so jointed and crushed that it was difficult to obtain a piece large enough for a microscopic slide, and the specimen selected broke into fragments in grinding. This rock forms a band, striking across the ridge in concordance with the foliation of the underlying schists. Under the microscope the rock is seen to be entirely devitrified, and the microcrystalline structure of a typical felsite is very apparent. Even minute fragments, which have remained entire in grinding, are brecciated. The cracks are usually marked by iron-oxide, and, occasionally, when wider than usual, are filled by quartz or by mica. There is a rough parallelism in the structure, and this incipient foliation is sometimes accentuated by a little mica.

2. A few feet below the last, and separated from it by soil. The rock is still felsite, much sounder under the hammer than No. 1. Microscopically examined, the field is seen to be clearer, the parallel structure is more distinct, and there is a larger proportion of mica. This rock has evidently been porphyritic, for there are several deformed masses of quartz on the slide. One of these is eye-shaped, and tails out at each end in a stream of minute granules.

3. About 15 feet of schistose rock, forming a band below No. 2, but continuous with it. Some of it is hardly distinguishable from the rock above, but the laminated structure is more evident. In other seams the foliated appearance is more marked, and a complete gradation can be traced between the modified felsite and a true schist. The change is seen even on the ground in the increasing distinctness of the lamination proceeding *pari passu* with the growing thickness of the films of mica on the planes of fissility. These indications are entirely confirmed by the microscope. The following gradation is seen in three specimens taken from the same band, within a yard or so from each other.

No. 294. Felsitic appearance in hand specimens, but slightly laminated. Under the microscope the parallel structure is seen to be due to intermittent folia of a green mica, in irregular bundles of fibres and sometimes dirty. This part of the rock also must have been a porphyry, for the slide shows several eye-shaped masses of crushed quartz which have caused the folia of mica to curve out of their course, forming, as it were, eyebrows to the quartz, both above and below, just as in the crushed granite described above (p. 529). Some parts of the slide display the felsitic structure, as above; but where the mica is most abundant the granules of the ground-mass are often of larger size and polarize in bright colours. Mineral differentiation would thus appear to have proceeded a stage further.

No. 295. The change in the felsite is more advanced. The rock chiefly consists of elongated granules of quartz arranged in a linear manner, with mica lying between them in microliths, so as sometimes to form a partial sheath. Some of this mica is transparent, polarizing in bright colours. Patches of the same mica and some felspar are also present. Distinct seams of mica and felspar, parallel to the longer axes of the quartz-grains, accentuate the foliation.

No. 296 is generally similar to the last. In about the middle of the slide is a very quartzose seam, in which the grains are much larger than in the previous specimens. It is not a vein, but a true folium, parallel to the rest. It passes by the gradual introduction of mica into a broad, very micaceous band, which graduates insensibly into a zone displaying a structure strongly suggestive of the micro-felsite, but a few microliths of clear mica are present. Some parts of the hand-specimen also have a very felsitic look under the lens.

No. 299 is from one of the several narrow micaceous bands inter-laminated with the more quartzose schist. It is an indubitable mica-schist. The mica is the white variety. It forms about half the mass, a great part of it being in distinct folia, which sometimes undulate. Some of the quartz has the same appearance as in Nos. 295, 296, the granules being more or less sheathed with mica. A few lenticular "eyes" of quartz are rather suggestive of the crushing of a porphyry; but on this I do not speak decisively. I am quite satisfied, from a very careful study on the ground, that these micaceous seams cannot be regarded as foreign fragments of schist entangled in the crushed felsite.

These modified felsites, now schists, form a low vertical cliff, 30 or 40 yards long, in which the rock is continuously exposed. I worked along the strike to the western end and found similar schists, some of them highly quartzose, passing occasionally into a material like a quartzite, and into felsitic rock like the first named. The different varieties were not always interbanded, but often passed into each other with some irregularity. That they all belong to the same mass I have no doubt. The rapid variations in the metamorphism agree with the sudden changes noticed in the crushed granite. A specimen of one of the quartzose varieties, almost like a quartzite, was examined microscopically. In structure it is intermediate between a quartzite and a quartz-schist. There is very little orientation in the quartz, which is frequently in large granules. Mica is in small proportion. Much of it is in clear microliths, which occasionally form a partial sheath to the quartz-granules, as in the other schists of the locality, but more frequently they have a rough orientation in one direction; occasionally they accumulate into imperfect folia. Parallel with this foliation are several cracks, which are more or less filled in with mica and iron-oxide. Some, if not most, of the mica in the cracks is the same white variety which prevails throughout the slide. This parallel cracking, coincident with the foliation, is another interesting analogy between this schist and the crushed granite, and is of course suggestive of similarity of causation.

B. Injection-Schists, or those in which the Banded Structure is due to the Parallelism of Intrusive Veins.

Two varieties of this rock are here described.

Duplex Diorite-gneiss, formed from veins of Diorite in Diorite.—

This fine-banded rock is common in one of the quarries at North Malvern. Parallel seams of grey granitoid diorite (No. 3) are enclosed in a black variety (probably No. 1). The differences between the ordinary diorites and their gneissic representatives certainly do not militate against my theory of the origin of the latter. The following points may be noted :—

In the massive black diorite there is some epidote and chlorite and a little green biotite, but in the gneiss there is a much larger proportion of biotite, and most of it has a definite orientation parallel to the direction of the adjacent vein. Some hæmatite also, which is in lath-shaped forms, is similarly orientated. The felspar of the ordinary diorite is cloudy, rarely showing plagioclase-twinning, and contains numerous clear microliths. In the gneiss the felspar of this diorite is rather clearer and sometimes displays striping. Comparing the unfoliated grey diorite with the grey variety in the gneiss, there is no material difference observable. The crystallization of the latter is larger, but in both cases the felspar is predominantly plagioclastic, and the proportions of hornblende, biotite, epidote, and quartz are about the same.

Owing to the want of continuous sections, I was unable to trace

an actual passage between the massive and the foliated diorites; but if the former were diorites, so were the latter, and I submit that there is nothing in the parallelism of the veining inconsistent with the theory of an igneous origin. But the description of the next variety of gneiss will throw additional light upon this question.

Granite-diorite-gneiss, formed from veins of Granite in Diorite.—This is the most conspicuous gneiss in the Malvern Hills. The gneiss itself and the rocks out of which it is constructed constitute about one half of the entire mass of the range. The diorite is black and of medium grain (No. 1). The production of the banded structure is well seen in the long ridge extending between the Wych and the Wind's Point. At the western quarry on the south side of the Wych there is a mass of the diorite with granite veins. It appears to pass into the gneiss of which the section chiefly consists, but junctions are obscured by *débris*. Similar rocks, in which there is the like association of massive and foliated mixtures of the diorite and the granite, are seen at intervals along the crest of the ridge to the south. At the top of the third summit the relations of the rocks are well seen. At one spot the granite is intrusive in the ordinary irregular veins, but it passes rather abruptly on the north into a rock in which the veins strike in a definite direction to the north-west, producing the banded structure of a gneiss. This rock is also well exposed about the Wind's Point.

The granite-seams in the gneiss vary considerably in thickness. Sometimes they are continuous for yards, but frequently they are lenticular in section. They often behave like veins in their rapid attenuation and in their branching habit. Their parallelism is by no means uniform, as they sometimes pass obliquely across the inter-banded diorite. Comparing microscopic specimens of this gneiss with slides from the unfoliated vein-structures in the Wych quarry, I do not hesitate to say that it would be impossible to determine which was gneiss and which was vein-structure. In both cases there is some epidote and chlorite produced in the diorite at the junction of the granite, and for a little distance from it, while the granite is slightly cracked.

This banded gneiss is, then, a binary mixture of igneous rocks, in which regional pressure has produced a parallelism of the granite-veins.

4. GENERAL REMARKS.

As this paper is strictly introductory, the evidence offered is incomplete; but it will perhaps suffice to prove that some of the Malvern schists are produced out of igneous rocks, and to create a presumption in favour of a similar origin for other varieties.

In the formation of some of the schists, the chemical and mineral changes have been very great; but into this division of my subject I have barely entered in the present communication.

Association of the Gneissic Rocks with the Igneous masses.—It is generally true that particular varieties of gneiss and schist occur in the vicinity of the igneous masses to which they are respectively

most nearly related in mineral composition. A few examples are here given.

In the North Hill we have large masses of several kinds of diorite penetrating each other in veins, and it is in this locality that we find the diorite-gneisses, simple and duplex.

North of the Wych the above-named diorites are intermixed with granite, and here we have a variety of gneissic rocks of more complex structure.

Between the Wych and Swinyard's Hill there is little besides black diorite and granite, and here we chiefly find the banded granite-diorite-gneiss.

Swinyard's Hill consists largely of granite, and it is in this ridge that the flaggy quartzo-felspathic schists occur.

In Midsummer Hill there are masses of coarse diorite, and the gneissic rocks in association with them are certainly more allied in mineral composition with this diorite than with any other igneous rock of the region.

Raggedstone Hill contains schists widely differing from any of the above, and here the associated igneous rocks are felsite.

These associations cannot be due to accident, and even if no direct proof of actual conversion could be offered, they would be of weight in the argument.

Absence of Stratification.—Except* perhaps in the Raggedstone Hill, I could detect no true bedding in the crystallines of the Malvern Hills. The zones of igneous and foliated rock, though they have a predominantly north-west strike, behave more like veins than strata. Where a sufficiently large surface is exposed in plan, we find the bands, whether massive or schistose, rapidly thin out. For example, on the crest of the ridge about half a mile north of the Wych the attenuation is usually from east to west. Fig. 3 shows a part of one of the exposures in this locality.

Age of the Rock.—I see no reason to doubt the received views as to the age of the greater part of these rocks. At the south-western extremity of the Raggedstone Hill, the Hollybush Sandstone rests at a low angle upon the edges of nearly vertical schists. The old rocks of the Salopian district afford confirmatory evidence. The Uriconian conglomerate of Charlton Hill contains several varieties of plutonic rocks, most of which can be matched in the Malverns, and these Uriconians are themselves older than the Longmynd series †. It is possible that the felsites and the schists formed from them are of a younger epoch.

Period of Metamorphism.—The most effective pressures may have acted at more than one period; but there is no doubt that the metamorphism was substantially complete before Cambrian times, since it is incredible that a force producing a strike transverse to the ridge could have acted without dislocating the strike of the flanking Cambrian and Silurian strata.

* After further research I think it no longer necessary to make even this slight reservation.—C. C., July 20th.

† Quart. Journ. Geol. Soc. vol. xlii. p. 481.

Schistosity, whether produced before or after Consolidation.—The evidence I have submitted points towards the latter alternative. In some of the diorites of the North Hill we have seen that the intrusive veins passed along planes of jointing and contained fragments of the enclosing rock, as in Galway. Then, too, the schists formed from the granite and the felsite are the effect of crushing. I prefer, however, to postpone the more adequate discussion of this question.

Fig. 3.—*Plan of Vein-structure in Schistose Rocks.*

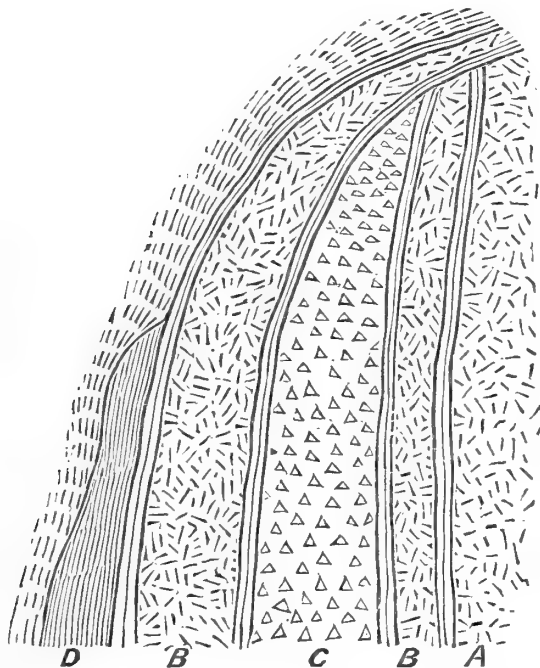

- A. Coarse granitoid rock with biotite.
- B. Bands composed of granite-veins, with seams of dark mica and of coarse rock (A) foliated.
- C. A vein macroscopically like a fine-grained diorite. Under the microscope it is seen to consist of hornblende, two micas, epidote, and quartz, and has a rude foliation in a specimen taken at the margin.
- D. Black schist, chiefly mica, penetrated by small granite-veins.

5. SUMMARY.

1. Many of the gneissic and schistose rocks of the Malvern Hills were formed out of igneous masses and veins. Amongst the materials which underwent the metamorphism were several varieties of diorite, a granite, and a felsite.

2. The parallel structure has been caused by regional pressure. This conclusion is proved by the intense contortion of granite-veins, and by the mechanical effects recognized in the rocks under the microscope.

3. The products of the metamorphism are divided into (1) Simple and (2) Injection-schists, the former elaborated out of one kind of rock, the latter out of at least two kinds, one being intrusive in the

other. The Simple Schists described are hornblende-gneiss, formed from diorite, mica-gneiss from granite, and mica-schist from felsite. The Injection-schists noticed were duplex diorite-gneiss, composed of veins of diorite in diorite, and granite-diorite-gneiss, of veins of granite in diorite.

In conclusion it was observed that :—

(1) Particular varieties of gneiss and schist generally occurred in the vicinity of the igneous masses to which they were most nearly related in mineral composition.

(2) No true stratification was detected, the bands of igneous and of foliated rocks thinning out rapidly, in the manner of veins.

(3) The received view of the age of the greater part of the rocks was not affected by the conclusions of the Author.

(4) The chief metamorphism was completed before the Cambrian epoch.

(5) Some, at least, of the schistosity had been caused subsequent to consolidation.

(For the DISCUSSION on this paper, see p. 514.)

38. *On the REMAINS of FISHES from the KEUPER of WARWICK and NOTTINGHAM.* By E. T. NEWTON, Esq., F.G.S. *With NOTES on their MODE of OCCURRENCE,* by the Rev. P. B. BRODIE, M.A., F.G.S., and EDW. WILSON, Esq., F.G.S. (Read May 25, 1887.)

[PLATE XXII.]

At the meeting of the British Association which took place last September, at Birmingham, the Rev. P. B. Brodie called attention to some specimens of fishes which he had obtained from the Upper Keuper of Shrewley. The specimens, which he has kindly sent to me for examination, are, unfortunately, very fragmentary, but still many of their characters can be deciphered; and seeing that Ganoid fish-remains from these deposits are of such rare occurrence, it is very desirable to place on record any fresh evidence which may be brought to light. Portions of seven specimens have been found, the best preserved (Pl. XXII. fig. 1) showing the left side of the body, minus the head and nearly the whole of the tail, but with parts of the dorsal, pectoral, ventral, and anal fins preserved *in situ*, with one or two rays of the tail-fin. In its present condition the specimen measures one inch and a half in length.

The second specimen (fig. 2) seems to include the whole of a fish; but it is so curved round, twisted, and crushed, that its form is well-nigh obliterated. When perfect, it probably measured two inches and a half in length. The large fulcra of the tail-fin are well seen from above; but with the exception of one or two plates, probably belonging to the head, little of the structure can be made out.

The third specimen (fig. 3) appears to be a head with the right pectoral fin and a portion of the body; but none of the bones of the head are preserved, and there is merely an outline in the form of a head in front of the pectoral arch. Two other fins are preserved on this block of stone, but they seem to be parts of another fish. The fourth specimen is a portion of a body with the ventral fin (fig. 4) preserved.

The fifth and sixth specimens (figs. 5, 6) are portions of tails. The seventh specimen, now in the British Museum, is a body with perhaps a fragment of the head, but without any tail or fins. The scales, in the middle of the side, have their hinder margins denticulated (fig. 7).

So far as preserved, these specimens are much alike, and there is nothing to lead to the supposition that they belong to more than one species. Judging from the best specimen (fig. 1) the body is comparatively deep, its entire length, when perfect, being only about two and a half times the depth. At the front part of this specimen there is a curved fragment, which seems to be part of the pectoral arch, and a little behind this there are traces of the pectoral fin. The form of this fin, however, is better shown in another specimen (fig. 3). If the lower margin of this specimen (fig. 1) be divided into three equal parts, then at the junction of

the first and second thirds will be the attachment of the ventral fin; and at the point between the middle and hinder thirds the beginning of the anal fin. The form of the ventral fin is best shown by specimen number four (Pl. XXII, fig. 4). The pectoral, ventral, and anal fins are of moderate size; but the single dorsal fin is large, with strong and seemingly articulated rays, while its anterior border is provided with well-developed fulcral scales. This fin begins nearly opposite the ventral fin, and seems to have extended backwards almost to the anal fin; but the hinder part being broken away, its exact extent cannot now be seen. Several ridges and grooves extending downwards from the dorsal fin indicate the presence of strong interspinous bones. The tail-fin is not preserved in number one (fig. 1); but the fragments of tails (figs. 5, 6) show that the upper lobe was larger and stronger than the lower, and had its upper margin furnished with particularly large fulcra (see also fig. 2), and its sides covered with elongated spindle-shaped scales. The sides of the body are covered with comparatively strong, shining, rhomboidal scales, which in the middle region are large and from two to three times as long from above downwards as they are from back to front. Towards the tail, as well as above and below, the scales become smaller and nearly equal-sided. The surface of the scales is smooth and shining; but on some of them, especially towards the tail, two or three indistinct oblique ridges run from front to back. In the first specimen (fig. 1) the hinder border of the scales is imperfect, and it is not clear whether this was smooth or denticulate; but specimen number seven has some at least of the body-scales finely denticulate (fig. 7). One of the tails (fig. 6) also shows that in some of the scales the indistinct ridges end in points on the hinder margin.

Unfortunately none of the specimens give any clear information as to the form of the head, or of any of its bones or plates. The restored outline of figure 1 is hypothetical, and is merely added to give a better idea of the position of the parts preserved. In the position where the bones of the head might be expected (figs. 2 and 3) there are only indistinct traces, which may be bones partially dissolved, and these appear granular on account of the sandy matrix beneath. Specimen number 2 shows what seems to be a comparatively large conical tooth near the end of the snout (fig. 2, *a*). In the opercular region there is a broad plate (*b*) with two tooth-like prominences at its hinder border, which may be one of the opercular bones; and a strongly striated plate (*c*) seen a little further back will probably bear a like interpretation. The seventh specimen also shows a similar striated plate.

The only ganoid fishes which have been described from British Triassic strata are the unique specimen of *Dipteronotus cyphus*, from the Bunter of Bromsgrove, described by the late Sir Philip Egerton*, and the *Palæoniscus superstes*, also described by the same author†, from a specimen found by Mr. Brodie at Rowington, in

* Quart. Journ. Geol. Soc. vol. x. p. 367 (1854).

† *Ibid.* vol. xiv. p. 164 (1857).

beds of the same Upper Keuper age as those which have now yielded the specimens above described. To neither of these Triassic fishes can the Shrewley specimens be referred. In the form and position of the fins the Shrewley specimens agree with *Semionotus*; but with such imperfect material, more especially the absence of information as to the nature of the head, the generic affinities of this fish must be uncertain, and I am unable to find any described species with which it will agree. Amongst the forms described by Agassiz, *Semionotus striatus*, from the Lias of Seefeld*, is perhaps the nearest to our fossil; but besides being much larger, this has all the scales of a more uniform size. In this latter particular *S. Nilssonii*† is more like, but in other respects it is even further removed from, our specimens. Sir Philip Egerton described three species of *Semionotus* from beds, said to be of Liassic age, at Castellamare‡; but the descriptions of these are sufficient to show that they are not the same as the Shrewley Triassic fishes.

If it should be thought desirable to have a name for such rare British fossils, it is suggested that the species be called after its discoverer, *Semionotus Brodiei*.

Mr. E. Wilson, at the British Association Meeting at York§, called attention to the discovery of fossil fishes in Keuper beds at Nottingham. In the abstract of this paper it is said that "The specimens he obtained have been examined by several competent authorities; but, unfortunately, their state of preservation is so bad that nothing certain can be made out as to their precise zoological affinities. Dr. Traquair, however, believes that they probably belong to some species, new or old, of the genus *Semionotus*." No further account seems to have been published; but Mr. Wilson has been good enough to let me see these specimens. A few of his best examples were presented to the Nottingham University College Museum; and through the courtesy of the museum authorities and of the Curator, Mr. J. W. Carr, I have had the opportunity of examining these also. The number of fishes in this deposit must have been very great, as will be gathered from the notes by Mr. Wilson (p. 542). Many of these have the scales well preserved; but unfortunately none give any satisfactory clue to the form of the body. One of the most perfect is on a small slab belonging to the Nottingham Museum, and is marked No. 1. In size, as in other respects, this agrees fairly well with the Shrewley fishes; it is lying partly on its back, so as to show both the ventral fins and above them the dorsal fin; the tail is twisted round, so that its upper border is now turned downwards. The position of the head is indicated by some irregular bony plates; but its form is uncertain. The moderately heterocercal tail and the position of the dorsal and ventral fins agree with *Semionotus*, and possibly the fish may belong to the same species as those discovered by the Rev. P. B. Brodie. The dorsal fin-rays which are preserved are entire and not articulated, as in the Shrewley specimen; it may be, however, that these

* 'Poissons Fossiles,' vol. ii. p. 231.

† *Loc. cit.* p. 229.

‡ Proc. Geol. Soc. vol. iv. p. 183 (1843).

§ Rep. 1881, p. 637.

are anterior rays, while those preserved in the Shrewley fish are not the front ones. Another specimen, also belonging to the Nottingham Museum, and, apparently, part of a similar fish, has these entire dorsal fin-rays very well shown (Pl. XXII. fig. 8).

On the same slab with No. 1 specimen there are fragments of what appears to be a Palæoniscoid fish. This is a portion of an extremely heterocercal tail (marked No. 2), the upper lobe being covered by numerous slender elongated scales. Some of the more anterior and ventral scales of this fragment have longitudinal striations; and other fragments on the same slab, with strongly striated scales (marked 3 and 4), probably belong to the same fish. The markings on these scales are not easy to decipher, but there seem to be five or six oblique ridges traversing the exposed part of the scale. Figure 9 fairly represents one of these scales, which are much like those of *Elonichthys* given by Dr. Traquair*.

On another slab there are fragments of a larger fish, as indicated by some masses of scales; but these are too fragmentary to call for more than a passing notice.

Notes on the Upper Keuper Section at Shrewley where the Fish were found, and on the Trias generally in Warwickshire. By the Rev. P. B. BRODIE, M.A., F.G.S.

As a rule, the Trias in Great Britain, considering its extent and thickness, is noted for the paucity and rarity of fossils, perhaps it is the most unfossiliferous of all rocks containing organic remains in this country, especially when compared with the abundant fauna and flora of the New Red Sandstone in Europe and other parts of the world. Any addition therefore to our knowledge in a field so comparatively barren is of considerable interest to the Palæontologist. It is now many years ago since I discovered *Palæoniscus superstes*, apparently the last of the genus, in the Upper Keuper at Rowington. Last summer, in company with my son, Mr. Douglas Brodie, I visited the sandstone-quarry at Shrewley, and he drew my attention to some obscure remains on a slab of sandstone which, when cleared, turned out to be portions of fish, unfortunately fragmentary and ill preserved, belonging to the genus *Semionotus* †, which, though frequent in the German Keuper at Coburg, Stuttgart, and elsewhere, has not been previously recognized here. On a second visit I found a few more in a somewhat better condition, all of which I placed in Mr. Newton's hands. On the slab on which

* Pal. Soc. 1877, pl. v.

† Another and larger fish was found at Shrewley some years ago, but the owner will not part with it nor allow it to be figured or described. I showed a photograph I have of it to Sir P. Egerton, at the meeting of the British Association at Exeter in 1869, and he thought it might be a species of *Semionotus*. It measures from head to tail about 5 inches in length and half an inch broad in the centre of the body; it stands out in relief, lying on its back on a block of sandstone, and resembles in its mode of preservation some of the fine fish from the Ilminster Lias, discovered by my friend the late C. Moore. In the New Red Sandstone of North America several fossil fish have been met with and will shortly be figured and described by Dr. Newberry, of the School of

the first specimens were found were two impressions of footsteps of a large *Labyrinthodon*, and I fancy that the whole number, seven, may have been lying on the surface of one large slab afterwards broken on removal. The following section of the quarry will show the probable position of most of the fossils which occur there :—

	ft.	in.
1. Soft, brown-coloured sandstone, current-marked	0	11
2. Green marls, more or less sandy.....	4	7
3. Friable sandstones, in beds divided by green marl, softer at the top, getting harder at the bottom, with green marly surface.....	7	2
4. Seven or eight beds of sandstone of variable hardness, with <i>Estheria</i> , divided by marls, the bottom rock the hardest	5	0
5. Hard tea-green marls with <i>Estheria</i>	7	0
Total.....	24	8

This section faces the south; at the east end of the quarry there are about 20 feet of red marls, above the green marls and thin-bedded brown sandstone, Nos. 1 & 2. The strata are nearly horizontal. The 'bottom rock' is exposed on the canal at Rowington, where it has a slight dip, owing to a local disturbance, and it appears again on the road between that village and Shrewley, and elsewhere. The lowest bed in No. 3, probably containing the fish, is a rather soft, gritty sandstone, made up of small grains of white quartz and other variously coloured rolled material, very small, loosely connected together, and readily broken. Here and there this sandstone is traversed by bands of green marl. The most abundant organisms in this bed, which have been known for a long time, are the remains of Cestracionts, consisting of teeth, palatal and cutting (the latter very rare), of several species of sharks, with the dorsal spines and, occasionally, portions of the shagreen. I have in my collection a series of small palates, united together, which is a unique example from the Trias here. A similar stratum, with similar fossils, occurs at several localities in Worcestershire. Footprints of *Labyrinthodon*, generally of small size, are occasionally found on the surface of the sandstones; and at Rowington remains of plants in a very imperfect condition, among which is *Voltzia* in fructification, and some small fruits resembling the Jurassic *Carpolithus*, so called. The 'bottom rock' is an excellent and durable building-stone, and was formerly largely quarried at Rowington and other places. In most works on geology the New Red Sandstone is simply classed as a series of strata of variously coloured

Mines, New York. He informs me that he has enumerated about twenty species from the American Trias, viz. :—

<i>Catopterus</i> , Redfield	6	species.
<i>Ischypterus</i> , Egerton= <i>Palæoniscus</i>	12	„
<i>Ptycholepis</i> , Agass.	1	„
<i>Diplurus</i> , Newberry	1	„

Dr. Newberry states that the American genus *Ischypterus* is so near to the genus *Semionotus*, that if found in Europe, Agassiz would have referred it unquestionably to that genus.

marls and sandstones, including the waterstones at the base. Now there are in Worcestershire several marls and sandstones, including the Waterstones, having at the bottom the hard rock above mentioned, overlying green marls with *Estheria*, succeeded by a thick stratum of red marls, which evidently come between these and the lower Waterstones at Warwick, Leamington, Cubbington, and elsewhere, so that the New Red in this district might be fairly divided into Upper and Lower Keuper, with two important beds of sandstone, one above and another below, separated by red marls, which would form hereabouts the dividing line. The same thing applies to the neighbourhood of Rugby, and is, I see, adopted by the local geologists there. The same subdivision is also adopted by the Rev. J. Mello for the Cheshire Trias; and I think it might be generally and advantageously adopted where these two sandstones, which differ lithologically, are closely separated by a thick intervening mass of red marl. The Waterstones are famous for the number (comprising nine genera) of Salamandroid Batrachians, a large number and variety of which have been found at Warwick, Leamington, and Coventry; and a unique collection is preserved in the Warwick Museum.

I may add that although the red rocks of Kenilworth and Coventry have hitherto been assigned to the Permian, there seems every probability that a large proportion of the former will now have to be classed with the Trias.

Notes on the Triassic Beds at Colwick Wood, near Nottingham.

By EDW. WILSON, Esq., F.G.S.

The small fishes described were found by me in the summer of the year 1879, in the roof of a tunnel which was being driven through the side of the hill at Colwick Wood, near Nottingham, for the Leen Valley Outfall Sewer. They come from the Lower Sandstone or 'Waterstones' of the Upper Keuper, which at this point rest upon the 'Basement-beds' of the Lower Keuper. The fishes were apparently limited to the lowest stratum of the 'Waterstones,' a bed of greenish-yellow sandstone 10 inches thick, with intercalated streaks of red and green marl, and a seam of pebbles at its base, and to the bottom inch or two of that stratum. This bed may be seen cropping out in an adjoining field on the hillside which here forms the escarpment of the Trent Valley, but it is not fossiliferous at that point; and although there have been many opportunities of examining the strata at the same horizon on the east side of Nottingham, and at other places in the vicinity, no traces of any similar organisms have, so far, been discovered elsewhere in the district. In addition to the exceptional interest that is always to be derived from the presence of organic remains in Triassic rocks, as a rule so barren of life, there were two points specially noticeable in connexion with the occurrence of these fossils in the Keuper at Nottingham; namely, first, the great number of the fishes, there being quite a shoal of them for a distance of thirty feet or thereabout, in the line of section, the individual fishes even lying over

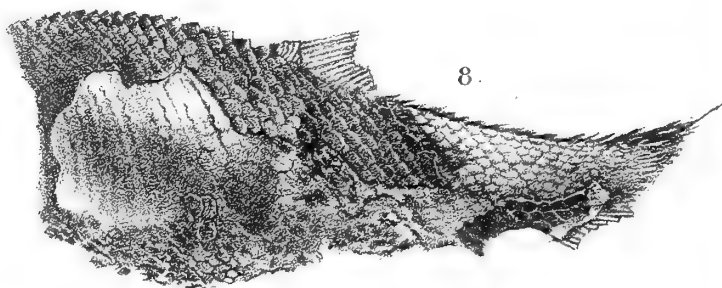
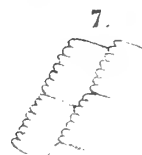
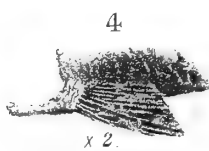
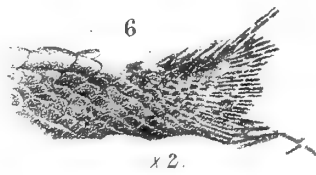
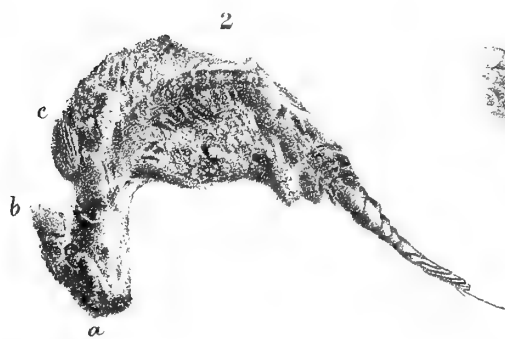
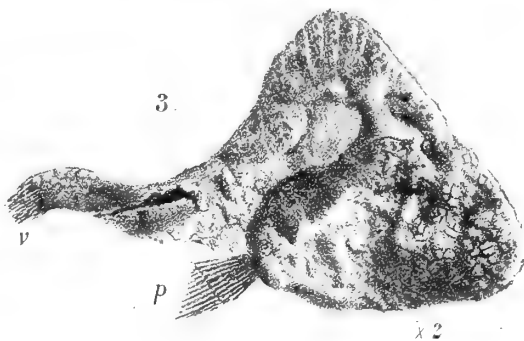
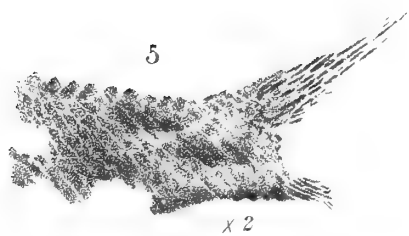
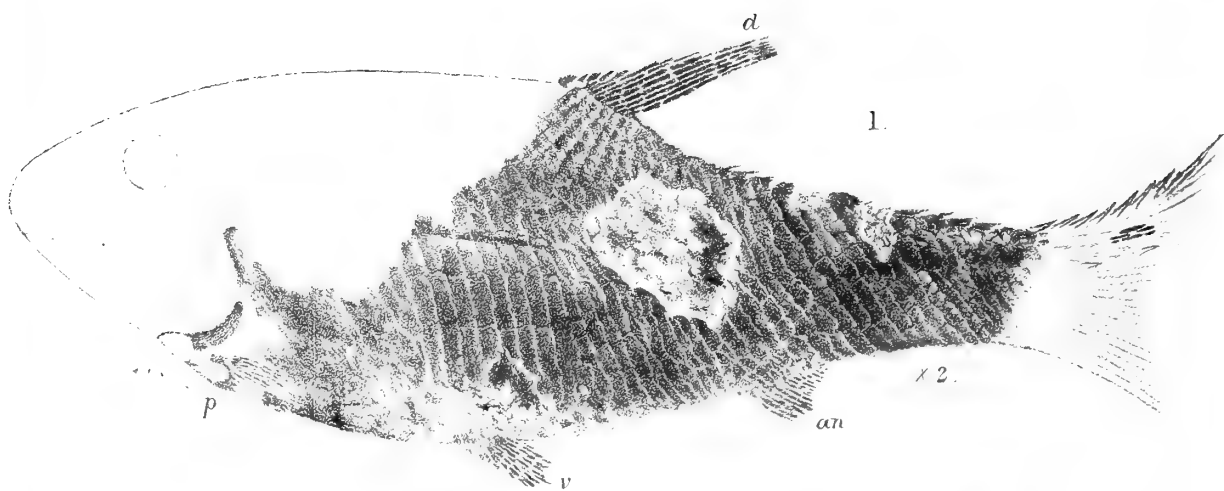

one another in the middle portion of that distance, but gradually becoming more widely separated in either direction until they finally came to an end; and, secondly, their occurrence at the junction of two subformations of the Trias, namely, of the Waterstones of the Upper Keuper and the Basement-beds (Lower Keuper). This may be, and probably is, merely an accidental coincidence. At the same time, it may be worth while to record the fact. The two series of deposits, at the junction of which this fossil shoal of fishes was found, are of very diverse characters, and were formed under very different physical conditions. The Keuper Basement-beds are a series of gritty, false-bedded sandstones with fractured quartzite pebbles and strange wedge-shaped intercalations of fine red marl and marly *débris*, irregularly bedded and showing clear signs of the existence of powerful currents as well as of considerable contemporaneous erosion. These deposits I believe to have probably had a fluvial origin. The Waterstones, on the other hand (at the base of which the fishes occurred, and to which series they belong), are regularly bedded fine-grained sandstones and marls, showing ripple-marks and sun-cracks*, and were evidently formed in waters which were tranquil but extremely shallow, and liable to entire and perhaps rapid desiccation. These waters were in all probability those of saline lakes or lagoons. Possibly the fishes found at Colwick may have become entrapped in the shallows of such a lake, and killed in numbers by the drying-up or the increasing salinity of the water.

EXPLANATION OF PLATE XXII.

- Fig. 1. *Semionotus*, found by the Rev. P. B. Brodie in the Upper Keuper of Shrewley, twice natural size. *d*, dorsal fin; *p*, pectoral fin; *v*, ventral fin; *an*, anal fin. The head and greater part of the tail are wanting, but their probable form is indicated by a hypothetical outline.
- Fig. 2. A much crushed specimen, natural size, showing the large fulcral scales of the tail.
- Fig. 3. Another example, twice natural size, showing part of head, pectoral fin, and possibly part of ventral fin.
- Fig. 4. A fragment, showing ventral fin, twice natural size.
- Fig. 5. A tail, twice natural size, showing its moderately heterocercal character.
- Fig. 6. A similar specimen, also twice the natural size, showing the large fulcral scales.
- Fig. 6 a. A few of the scales, further enlarged.
- Fig. 7. Scales, enlarged, from a specimen presented to the British Museum by the Rev. P. B. Brodie, showing their denticulate margins.
- Fig. 8. One of the numerous specimens of *Semionotus* found by Mr. E. Wilson in the Trias of Colwick Wood, near Nottingham; natural size. Other examples show that the ventral fins (and probably the anal fin) were situated as in figure 1 above.
- Fig. 9. A scale, enlarged 20 diameters, of one of the Palæoniscoid fishes, also found by Mr. E. Wilson in the Trias of Colwick Wood.

* In these lowest beds of the Waterstones at Colwick I found the *stem* of a land plant having the appearance of *Equisetites columnaris*, and probably allied thereto. Unfortunately it was only a sandstone cast, and too friable to remove.

39. *On the LOWER PART of the UPPER CRETACEOUS SERIES in WEST SUFFOLK and NORFOLK.* By A. J. JUKES-BROWNE, Esq., B.A., F.G.S., and W. HILL, Esq., F.G.S. (Read June 8, 1887.)

INTRODUCTION.

THE zonal subdivisions of the Cambridgeshire Chalk were first described in 1880*, and more fully in the Memoirs of the Geological Survey, in 1881†, the outcrops of the Totternhoe Stone and the Melbourn Rock having then been traced as far as Burwell and Newmarket respectively; but the survey of the Suffolk Chalk having been previously completed, the lines were not continued on the Survey map.

The section exposed in the cliffs near Hunstanton has often been described, but the beds there seen are very different from those which occupy a similar stratigraphical position near Newmarket; it was evident, therefore, that between these two places the beds forming the lower part of the Chalk underwent a considerable amount of lateral change, and that, until more was known of the manner in which one facies of the Lower Chalk passed into the other, no correlation of the Norfolk and Cambridge sections could be more than suggestive.

Moreover, in the absence of this information, one of us has found much difficulty in correlating the subdivisions of the Lincolnshire Chalk with that of the Midland counties, and he felt that when once the constitution of the Norfolk Chalk was properly understood, that of Lincolnshire, which bears great resemblance to it, would no longer offer any difficulty.

It being clear, therefore, that important issues depended upon an investigation of the changes that take place in the Cretaceous rocks as they pass from Suffolk into Norfolk, it was with the object of exploring this *terra incognita* that we started from Newmarket in June 1886, and worked rapidly northward as far as Shouldham and Marham in Norfolk. By this traverse we succeeded in obtaining some important information, which was communicated to the Director of the Geological Survey, the result being that Mr. Whitaker was sent into the district, and one of us accompanied him in continuing the work through Norfolk to Hunstanton. During this traverse the lines for the Melbourn Rock and Totternhoe Stone were drawn, and that for the Melbourn rock will be engraved on sheets 65 and 69 of the Geological Survey map. A third visit was made in September, and two others in the spring of this year, for the purpose of gaining further information on certain points, and superintending the execution of three borings which were made for the purpose of testing the accuracy of our conclusions at localities where little natural evidence was obtainable.

* Geol. Mag. dec. ii. vol. vii. p. 248.

† 'Geology of the Neighbourhood of Cambridge,' by W. H. Penning and A. J. Jukes-Browne, pp. 20 *et seq.*

The present communication therefore is based upon our joint investigations in the field, checked and confirmed by the results of the borings, by the examination of the fossils collected from the various exposures, and by the study of more than 150 rock-slices under the microscope.

The mass of evidence thus obtained will naturally be treated under the three heads of (1) stratigraphical evidence, (2) palæontological evidence, (3) microscopical evidence; and these are supplemented by the chemical analyses which the kindness of Dr. Johnstone enable us to adduce. We desire also to thank Mr. Whitaker for his assistance and cooperation in the field, and for his readiness to impart such information as he possessed.

§ 1. STRATIGRAPHICAL EVIDENCE.

For the purposes of description, it will be most convenient to divide our matter into three portions under the following heads: (a) the Gault and the Cambridge Greensand, (b) the Totternhoe Stone and Chalk-marl, (c) the Grey Chalk, Melbourn Rock and associated beds, tracing each division from south to north, and describing the exposures which we observed along the tract occupied by it.

A. *The Gault and Cambridge Greensand.*

On the eastern borders of Cambridgeshire, near Reach, Burwell, and Soham, well-sections prove the thickness of the Gault to be about 100 feet, the information obtained showing a variation between 90 and 110 feet at different places.

The greater part of the Gault lies below the surface of the Fen, so that little can be seen of it; but some fourteen or fifteen years ago many Coprolite-pits were open between Reach and Soham, and we quote the following observations from the 'Survey Memoir on the Neighbourhood of Cambridge' (p. 34) as indicating that the clay which here underlies the Coprolite-bed belongs to a different and probably higher part of the Gault than that on which it rests near Cambridge. The memoir says:—"The phosphate nodules extracted from these pits exhibited different characters from those obtained nearer Cambridge; there was a much greater proportion of lighter-coloured phosphates, and the fossils which occurred among these had not apparently been subjected to much rolling, but retained their shells in a more perfect state than usual—*Terebratulæ*, *Rhynchonellæ*, and *Exogyra* being especially common and well preserved. . . . Amongst the darker nodules there are some which have a greenish exterior, and the whole assemblage has a different aspect from those [of the pits] to the south, as if resulting from the erosion of differently constituted beds in the Gault."

It is also mentioned that at one pit near Reach "a second Coprolite-bed was worked in the mass of the Gault, about 8 feet below that forming the base of the Chalk-marl," the fossils from both beds being mixed in the washed heap.

Now it is remarkable that these phenomena are similar to those found near the southern termination of the Cambridge Greensand in Bedfordshire; the phosphates dug near Barton in that county exhibited a similar preponderance of light-coloured nodules, and it was specially observed* that their surfaces were fresher and less water-worn than those of the Cambridge nodules. It was shown, in the paper referred to, that these nodules were in all probability derived from the uppermost beds of the Gault, and the resemblances between them and the nodules from the Reach and Soham pits are therefore very suggestive; this point will be again referred to in the sequel.

The most northern locality where the Cambridge seam has been worked is near Wedd's Farm, about two miles north-east of Soham, where it was not far from the surface. Beyond this spot its course is unknown, and no line for the base of the Chalk beneath the Fenland has been drawn on the Geological Survey map (sheet 51, N.E.); there can be little doubt, however, that it runs below Mildenhall Fen, and probably passes out of sheet 51 into sheet 65, about a mile and a half north-west of Lakenheath. How far the nodule-bed continues at the base of the Chalk-marl is of course a matter which could only be decided by making a series of borings through the fen-beds along the line above indicated.

Gault is said to underlie the gravel of Shrubbs Hill, which is an island in Hockwold Fen, on the north side of the Little Ouse, but the base of the Chalk-marl seems to be still below the Fen-level.

Between West Dereham and Stoke Ferry the Gault once more rises above the level of the Fen, and forms a low-lying plain between the ridges of the Lower Greensand to the westward and the slope of the Lower Chalk on the east.

That this is really Gault we have not the slightest doubt. Mr. C. B. Rose, who was the first to describe it, seems at first to have had some doubt whether it was true Gault; but his hesitation was set at rest by William Smith, who identified it by the fossils he had found in it†, so that we find Fitton (in 1836) accepting its existence as an established fact. Mr. Rose afterwards succeeded in tracing the several detached exposures of this clay from West Dereham to Congham and West Newton, and records the finding of other Gault species‡. From this time, no doubt was ever thrown on the occurrence of Gault in West Norfolk until 1885, when Messrs. Reid and Sharman§ raised the question in the 'Geological Magazine,' and suggested that the whole of it was Chalk-marl, asserting that it contained a Chalk-marl fauna.

From their conclusions we entirely dissent, and our reasons for maintaining that this clay is really Gault have already been published, so that we need not repeat them here; but we think that

* See Quart. Journ. Geol. Soc. vol. xxxi. p. 262.

† Phil. Mag. vol. vii. (1835) p. 179 *et seq.*

‡ Proc. Geol. Assoc. vol. i. p. 234.

§ Geol. Mag. dec. iii. vol. iii. p. 55.

if Messrs. Reid and Sharman had traced the Chalk-marl through Suffolk and Norfolk, as we have done, and had realized the true position of the hard chalk exposed at Stoke Ferry they would never have published their suggestion.

In our brief communication to the 'Geological Magazine' we mentioned that, in order to decide the question, we had a boring made at Stoke Ferry, and had proved the existence of a glauconitic marl there, which rested on blue clay at a depth of $53\frac{1}{2}$ feet below the quarry floor (see p. 556).

We may also mention in this connexion that from the core of the Glauconitic Marl brought up from the bore at Stoke Ferry we extracted a small but perfect cast of *Avicula gryphæoides* in dark-brown phosphate of exactly the same appearance as the casts of the same shell in the Cambridge Greensand, so that we feel warranted in regarding this bed as an actual continuation of the Cambridge Greensand.

Another well-section, at a point a quarter of a mile south-east of the quarry, continues the succession, and shows 56 feet of Gault below the base of the Chalk-marl. The details are as follows:—

	feet.
Sand and Water.....	25
Chalk [<i>i. e.</i> Chalk-marl]	$13\frac{1}{2}$
Yellow Marl [? Glauconitic bed]	3
Blue clay [Gault]	56
Dark green sand	2
Beds of rock and sand [Lower Greensand]	15
	<hr/>
	$114\frac{1}{2}$

The three feet of "Yellow Marl" we regard as in all probability the glauconitic basement-bed of the Chalk-marl, which has a yellowish tinge, especially when contrasted with the whiter Chalk-marl above, and its assigned thickness agrees very closely with that of the bed proved by our boring. The clay below is, of course, the Gault, and the "dark green sand" is its basement-bed, in which the Coprolites occur at West Dereham.

For the details of this boring we are indebted to Mr. W. Whitaker, who obtained them from the well-borer himself, Mr. T. Tilley. The three sections taken together, namely, the open quarry, our boring, and Mr. Tilley's boring, give the complete thickness of the Chalk-marl and Gault at Stoke Ferry, the former being 75 feet and the latter 58 feet in thickness. We had previously calculated the thickness of the Gault, taking the breadth of its outcrop as two miles, and assuming a dip of 1° , to be 59 feet. We shall show in the sequel that the thickness of this clay rapidly decreases from this point northwards.

On the Gault-area the only sections are those to be seen in the trenches opened from time to time for the purpose of working the seam of phosphate-nodules which lies at the base of the clay. The best section open in 1886 was at the works one mile W.N.W. of Dereham Church; this showed from 10 to 12 feet of dark grey clay,

with a basement-layer (9 inches thick) of sandy glauconitic clay containing the "Coprolites." This layer rested directly on brownish sand, the line of junction being undulating, as if indicating erosion. Both here and at the other pits south-west of the church there was only one seam of nodules, and all the nodules on the washed heaps were of the gritty or pebbly phosphate, such as occurs in the zone of *Ammonites mamillaris* at Folkestone. In the older pits near West Dereham, phosphate-nodules of the darker compact kind usually found in the Gault occurred in the clay overlying the nodule-bed; but in the present workings only pale grey or buff-coloured phosphates occurred above the basement-bed.

Near the farm called "Muzzle," about four miles west of West Dereham, a good section of the lower part of the Gault can be seen in an old pit, where clay has been extensively dug for agricultural and other purposes. The lower part of the face is now hidden by a talus slope, due to weathering, but there yet remains a vertical section of about from 4 to 6 feet. This exposure has been considered by many writers to afford a proof of the existence of the Gault in Norfolk. Messrs. Reid and Sharman, however, as previously mentioned, refer it to the Chalk-marl. They visited this pit to obtain fossils "unmixed with derivative forms," and they consider the assemblage so obtained to be characteristic of the Chalk-marl rather than of the Gault.

We have examined the exposure carefully. All the fossils found here were met with in the face of the pit except *Ammonites interruptus*. Ammonites of this species were obtained by digging a little below the floor of the pit, and appeared common as soft-clay casts; but some of the interior whorls of at least one specimen were phosphatized. With the Ammonites were associated numbers of *Inocerami*, which appear to belong to *Inoc. concentricus* and allied species. The whole assemblage is unquestionably a Gault one.

The area occupied by the Gault north of West Dereham is much obscured by spreads of Boulder-clay, &c., but deep ditches give occasional facilities for following its outcrop. In one of these, to the south of Shouldham, Messrs. Reid and Sharman record a bluish-white marly clay, full of *Belemnites minimus* and *B. attenuatus* and *Plicatula*, which they refer to as Chalk-marl*. From the evidence we have obtained at Muzzle and West Dereham, and also further to the north, at Grimston, we believe this marly clay to be true Gault. Mr. Whitaker informs us that a boring at Narborough House passed through 85 feet of chalk, which was hardest near the base, then through 20 feet of blue clay or marl, reaching the Lower Greensand at 105 feet.

In the neighbourhood of Grimston we have been able to identify the Gault, and have ascertained its thickness by boring.

The point chosen for this operation was a pit about half a mile N.N.E. of Roydon Church, in which occurs a hard, grey, and gritty chalk, with green-coated nodules at its base, described by Mr.

* Geol. Mag. dec. iii. vol. iii. p. 55.

Whitaker* as the probable representative of the Totternhoe Stone. This hard grey chalk is underlain by exceedingly hard creamy-white chalk, which passes rather abruptly into a softish, grey, clayey marl. At the junction of these two the hard material was decidedly yellower, and it passed into the bed below as layers or lumps separated by the marl. The section obtained by digging and boring is as follows (fig. 2):—

Fig. 2.—Diagram of Section shown and obtained by boring in the Pit about $\frac{1}{2}$ mile N.N.E. of Roydon Church. (Scale $\frac{1}{8}$ inch to 1 foot.)

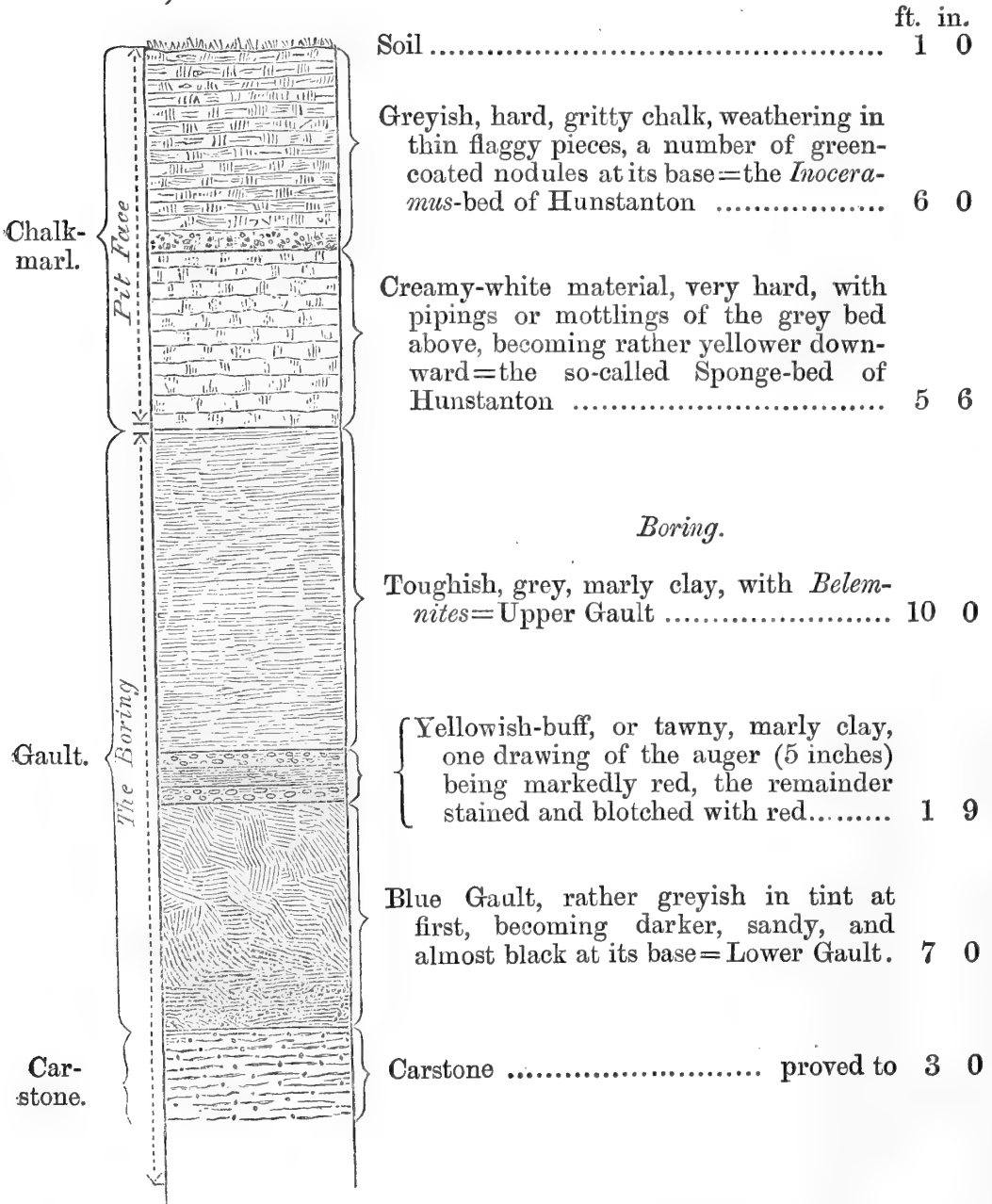

No hard beds were noted in boring, but subsequent examination

* Proc. Norwich Geol. Soc. vol. i. pt. iii. p. 238 (1884).

of the cores showed that hard material had been passed through, probably at the top of the blue Gault. Belemnites were found in the cores, and also in the lowest part of the hard Chalk-marl, but not higher.

About half a mile N.E. of Grimston-Road Station the following succession of beds, having a slight dip to the east, is shown in a shallow cutting of the railway. Entering from the southern end, a dark-grey calcareous clay is seen for about fifty yards. Some thirty yards south of the bridge which spans the centre of the cutting this clay is seen to be overlain by a bed of hard, bluish-grey rock, eight or ten inches thick. Two feet above this bed, and extending for almost the entire length of the cutting from this point to the north, rather more than a foot of the clay is coloured a bright reddish pink. This band is divided in places by uncoloured material. North of the bridge, a second bed of pale yellowish-grey rock, about eight inches thick, is seen above the red band, separated from it by a few inches of marly clay. The lower of these hard beds proved fossiliferous, the most abundant form being *Inoceramus concentricus*; associated with it were *Inoceramus sulcatus*, *Ammonites lautus*, and *A. rostratus*. The upper bed appeared to contain few fossils. *Inoc. concentricus* occurred sparingly.

The succession of these beds was further confirmed by following the course of the brook to the west of Grimston Church. The out-crop of the lower hard bed occurs just by a small field-bridge about a quarter of a mile S.W. of the church. It is easily identified by its fossils, which are the same as those from this bed in the cutting. Following upward the course of the stream, a grey marly clay is exposed on either bank, which, just above the hard bed, and rather closer to it than in the cutting, is tinged with pink. Above this is a second hard bed. At the confluence with the main brook of a small stream, which takes its rise immediately to the west of the church, hard, creamy-white Chalk-marl is seen, bared at this point from all sediment by the swiftly running water. This spring appears to rise at the horizon of the hard grey chalk noted at the Roydon pit, with which the material from the spring-head agrees. Belemnites occur from the lower hard bed to the Chalk-marl, very abundantly in the pink, more sparingly above it.

About a mile to the south-west, the same order of succession of these beds can be made out in the channel cut by the water rising from the Sow's Head spring. The water here appears to come out at the base of the hard Chalk-marl, for hard limestone, weathering yellowish and containing Belemnites, extends for some little distance down stream. Below this, with about the same interval of grey marly clay between them as at Grimston, are two hard beds, the lower containing the same fossils as before; and the marl above it being tinted a dull brownish pink, is probably the representative of the red band in the cutting.

There is perhaps some ground for doubting whether the hard beds seen in this neighbourhood occur continuously at the same horizon; for Mr. Rose notes a hard bed at Pentney only 2 feet

above the base of the Gault* ; but in both the brook-sections soft greyish-blue marl underlies the lower hard bed, below the outcrop of which the banks weather down, and the strata through which the water cuts its way are no longer openly exposed.

A small exposure was noted of grey clayey marl, with some pinkish streaks, just to the east of the gardens at Sandringham, in what appeared to have been an old pit close by the road. This we refer to the Gault. At a subsequent visit this exposure was covered up, but red clayey earth was seen just above the outcrop of the Carstone around some young trees which had just been planted.

That which we believe to be the final thinning-out of the Gault clay was found by boring in the large chalk-pit at Dersingham (for section see p. 560). Here, below the hard Chalk-marl, 2 feet of softish pale grey marl was found, and beneath this 3 feet of yellowish-brown chalky material, hard at the top, but passing down into $2\frac{1}{2}$ feet of red marly clay, which rested immediately on the Carstone.

This confirms a statement of the Rev. T. Wiltshire, who says † :—
“According to the statements of persons resident in the district adjoining Hunstanton, and who have seen inland sections opened for agricultural purposes, the blue Gault, with its characteristic Belemnite, rests on the Carstone at Flitcham, 10 miles south of Hunstanton ; but rather nearer the latter place, and still close to Flitcham, a red clay occurs immediately under the White Chalk, thus connecting the blue Gault with the Red Chalk.”

As will be seen in the sequel, the stratigraphical evidence is strongly in favour of the Red Chalk being the actual continuation of the Norfolk Gault, a conclusion which agrees with that arrived at by Mr. Wiltshire ; but it will be seen that the strength of this evidence lies in the identification of the overlying “sponge-bed” as the real base of the Chalk-marl.

B. *The Chalk-marl and Totternhoe Stone.*

The thickness of the Chalk-marl in Cambridgeshire is from 60 to 70 feet, and its upper beds, underlying the Totternhoe Stone, are well exposed in the large quarry at Reach and in the northernmost quarry at Burwell.

At Reach a face of about 30 feet is seen, the highest beds being tough and blocky, drying to a dull greyish white and being then fairly compact ; they are not really bedded, but split into large blocks with curved and largely conchoidal fractures, and the whole mass is divided by strong joints ; this “clunch,” as it is locally called, passes down to a softer and darker brownish-grey marl which towards the bottom of the section shades into a bluish shaly marl, these lower beds containing *Inoceramus latus*, *Ammonites varians*, and other fossils in some abundance.

The lower part of the Chalk-marl, as seen in the numerous

* Phil. Mag. 1835, vol. vii. p. 180.

† Quart. Journ. Geol. Soc. vol. xxv. p. 190.

Coprolite-pits between Cambridge and Soham, is a soft, argillaceous, bluish or greenish-grey marl, containing many small Brachiopoda.

The Totternhoe Stone is invariably found at the top of the Chalk-marl throughout Buckinghamshire, Bedfordshire, and Cambridgeshire; and the most northerly point to which it has hitherto been traced is the village of Burwell, in Cambridgeshire, where there are large quarries and good sections. These have been described in the "Geology of the neighbourhood of Cambridge" (Mem. Geol. Survey), so that a brief summary need only be given here. The stone is generally spoken of as a grey sandy chalk, but the roughness and apparent sandiness is probably due in great part to the quantity of the comminuted fragments of *Inoceramus*-shells which it contains. Its basement-bed is a remarkable stratum, consisting of hard, grey, gritty stone full of green-coated phosphatic nodules, which vary in size from that of a pea to that of a walnut or small potatoe; the thickness of this layer is from six to twelve inches and it is locally known as "brassil." At Burwell the uppermost bed of the stone is a course of compact grey freestone, about 3 feet thick, which is known as the "bond" course and forms the best building-stone of the quarries. The whole thickness of the Totternhoe Stone is not exposed in any of the sections, but is seen to be more than 13 feet.

The first locality beyond Burwell where we found traces of this stone was in the shallow cutting on the new railway nearly a mile north of Fordham Station. Much water is thrown out here, and as a level piece of ground has been left by the removal of material between the rail and the road, shallow trenches have been dug to facilitate the escape of the water; these excavations expose a portion of the basement-bed of the Totternhoe Stone, which is full of green-coated nodules like those of Burwell, and contains some fossils, such as *Pecten fissicosta*, Eth., and *Rhynchonella Grasiiana*, d'Orb. Only the bared outcrop of this bed is seen, and it probably dips eastward, the general features of the country suggesting that the long ridge on which the eastern part of Fordham stands coincides with a shallow synclinal trough. The cutting north-east of this point is chiefly through a kind of chalky wash overlain by a gravelly soil.

The "clunch-pit" three furlongs N.E. of Fordham Church appears to be in the top of the Chalk-marl, just below the horizon of the Totternhoe Stone; but we found fragments of the stone near the windmill three quarters of a mile N.N.E. of this, so that the hill east of the mill is probably an outlier of grey chalk based on the Stone.

At Isleham there are two large quarries, which have been worked for many years; both of these show sections of the Totternhoe Stone, very like those of Burwell, but the base is not exposed and there is no bed comparable to the "bond course" of that locality. The beds seen in the oldest quarry south of the church are:—

	feet.
Soil and rubble	2-3
Firm greyish-white chalk	4-6
Hard grey chalk mottled with darker grey in thin beds and known as "the hards"	2-3
Grey stone in massive blocks, seen for	6

The Totternhoe Stone is called "the blocks" by the quarrymen, and they stated that these extend for another 6 feet below the level then exposed, another course being then reached, which they call "the greys," and water comes in at 8 feet down. It would appear therefore that the stone is hereabout 12 feet thick, excluding "the hards," which are perhaps more fitly classed with the overlying chalk into which they merge. The blocky stone is burnt for lime, but is also used for walling and for small buildings when required.

The other quarry is about a quarter of a mile east of the church, and exposes a rather deeper section, but without showing the base of the stone. At this pit we were informed by one of the workmen that he had found a number of large stones in a hole at a depth of 22 feet from the surface; according to his account it was a cavity in undisturbed chalk, and the stones were mixed with material like rotten wood or decayed bones. We came to the conclusion that it may have been a stone-laden mass of drift-wood which had sunk to the sea-bottom at this spot and been imbedded in the Totternhoe Stone.

The railway-cutting by Isleham Station doubtless traversed the Totternhoe Stone, but it is now so grassed over that nothing is visible, and the outcrop on the other side of Freckenham Beck is entirely concealed by a wide spread of gravel.

The well at the Isleham waterworks, about half a mile west of Isleham Station, gave a nearly complete section of the Chalk-marl, the details being as follows, according to Mr. Hook of Soham, who made the boring:—

	feet.
Well sunk in Chalk	27
Bored in Chalk-marl with the Coprolite-bed at bottom	27
Bored in Gault for	23
	—
	77

Crossing the river Lark by West-Row ferry, we come to the large quarry which has been elsewhere described*, and which is remarkable for exposing a band of pink or light red chalk similar to one of those which occur in Lincolnshire. We need not repeat the details of this section, but may say that the beds are clearly in the grey chalk and must be some distance above the Totternhoe Stone.

The "clunch-pit," marked on the Ordnance map near the words "Western Ditch," is now disused and turned into a garden; but a small exposure beneath the hedge shows brownish-grey gritty stone, having the appearance of Totternhoe Stone, an identification which was afterwards confirmed by microscopical examination. We followed the slight feature made by the outcrop of this stone as far as Beck Row, the direction of the strike being about N.N.E.; but beyond that place the feature is completely obscured by the blown sand which overspreads so large a part of this district.

* Geol. Mag. dec. iv. vol i. p. 74; and Brit. Assoc. Rep. 1886, Sect. C, p. 664.

On the north side of the Brandon River, near Hockwold and Feltwell, grey chalk is again above the Fen-level, but none of the pits expose anything which we could identify as Totternhoe Stone. Grey blocky chalk in which we could not find any fossils, but which must be between this horizon and the Melbourn Rock, is seen in a quarry by the main road two furlongs north of Hockwold. To the westward, near Hockwold Grange, there is hard blocky grey chalk or "clunch," which appears to belong to the upper part of the Chalk-marl. A weathered exposure of this grey chalk occurs in an old pit near the Grange, *Ammonites varians* and *Inoceramus latus* being here as abundant as in the large quarries near Reach. At a small lime-kiln by the road, three furlongs north-east of the Grange, we saw about 20 feet of blocky grey chalk, which more resembled that above the Totternhoe Stone at Cherry Hinton than any part of the Chalk-marl, and the only fossil found was *Ammonites rhotomagensis*, which is not common in Chalk-marl; still the distance between the two exposures is so small, and the difference of level so slight, that we believe the latter to be still in the Marl.

There is another small pit by the roadside, north of White Dyke, and in the lower part of this are some hard dark grey beds with lumpy irregular surfaces, which greatly resemble the beds overlying the Totternhoe Stone at Isleham (see p. 554), but we afterwards found that similar beds appeared in the Chalk-marl.

South of Feltwell St. Nicholas, and near the windmill marked on the map, is a quarry from the face of which adits or tunnels have been driven, and the following section is exposed:—

	feet.
4. Chalky soil	1
3. Greyish-white chalk, rather hard	10
2. Hard grey chalk in thin irregular beds mottled with darker grey pipings, about	5
1. Softer and lighter blocky chalk, seen for	10
	<hr style="width: 10%; margin: 0 auto;"/> 26

The hard beds are like those at White Dyke, but the chalk below is certainly not Totternhoe Stone; it resembles the Chalk-marl of Hockwold Grange, and the comparison is confirmed by microscopical examination. The caves are excavated in this blocky chalk, the lower part of the hard beds being also removed, leaving the upper part of the latter to form the roof. If these grey beds are the same as those of White Dyke, we must infer the existence of a fault to account for their position at Feltwell on a higher level and more than a mile eastward of the former place.

Small pits exist near the edge of the fen north-west of Feltwell, and near Methwold Hithe, but do not expose anything of interest.

In the large quarries at Stoke Ferry we were able to identify the representative of the Totternhoe Stone, and the underlying beds must therefore be referable to the Chalk-marl. Of these 22 feet are exposed, and they consist of hard blocky dull white chalk, which

clinks under the hammer, and has a yellowish tinge on the weathered surfaces; no one would at first sight identify this with the Chalk-marl of Cambridgeshire, but its position is sufficient proof of its being on the same horizon, and it is similar to the hard blocky chalk of Feltwell and Hockwold Grange.

The section exposed at Stoke Ferry is as follows (fig. 3):—

Fig. 3.—Section at Stoke Ferry, partly seen in the quarry, and partly proved by boring. (Scale $\frac{1}{20}$ inch to 1 foot.)

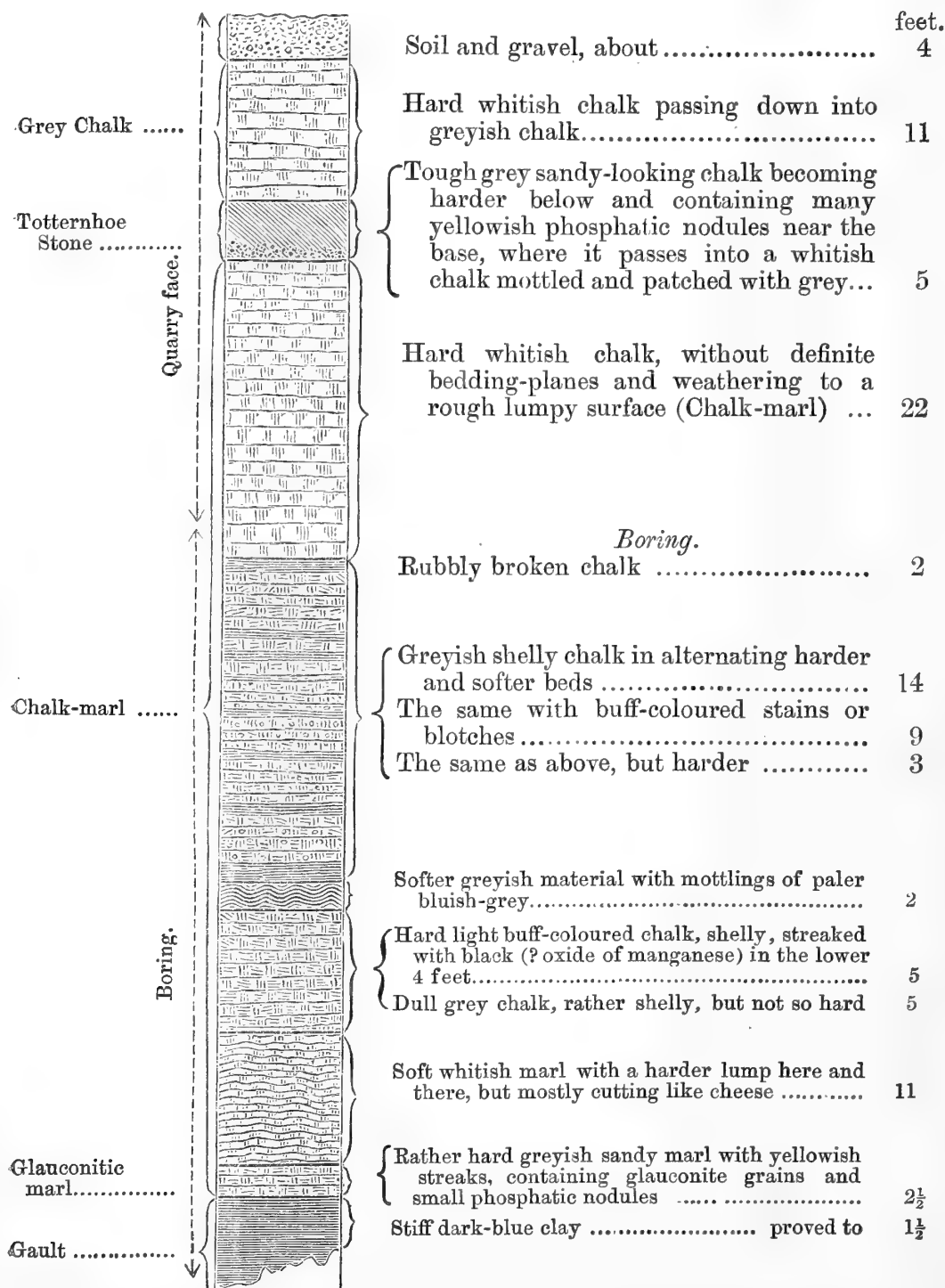

We think that there can be no doubt about this glauconitic marl being the representative of the Cambridge Greensand (Chloritic Marl), and by adding the thickness shown in the boring to that of the chalk between the quarry-floor and the base of the Totternhoe Stone, we get $75\frac{1}{2}$ feet as the total thickness assignable to the Chalk-marl.

The Totternhoe Stone has no definite top or base, even the "brassil"-like line of nodules being rather at the top of the mottled band than at the base of the grey chalk; this mottled band evidently consists of two distinct kinds of material, and looks as if it had been originally a layer of white chalk in which pipes and hollows had been excavated and filled up with the grey material; its depth is about 12 inches; it and the grey stone above split together into large blocks. None of the chalk in this quarry exhibits any distinct planes of bedding, but the band of Totternhoe Stone is fairly conspicuous on account of its grey colour.

The ridge formed by the hard beds of the Chalk-marl and Totternhoe Stone runs for some distance beyond Stoke Ferry, its strike being to the N.W.; but near Wereham it is capped and partially concealed by thick deposits of gravel. About a mile north-west of Wereham, and half that distance from West Dereham Church, there is a quarry exposing the following section:—

	feet.
Soil and chalk-rubble	$3\frac{1}{2}$
Rather dark grey thin-bedded gritty chalk	3
Yellowish-grey marly chalk with many very hard lumps on the weathered surface	8 to 12

The lower beds resemble the hard Chalk-marl of Stoke; but though the bed above had some resemblance to Totternhoe Stone, there were no signs of the "brassil"-like nodules which so invariably occur near its base. We think therefore that it is probably one of the harder beds of the Chalk-marl like those passed through in the boring at Stoke.

At Crimplesham the Chalk-marl passes beneath the Boulder-clay, by which it is entirely concealed for a space, and the next exposure seen was in a small quarry at Shouldham by the roadside south of the church. Here about six feet of tough yellowish-grey chalk in lumpy and irregular beds overlie two feet of soft grey shaly and silty marl, which is full of small green glauconite grains and contains many small green-coated phosphatic nodules; *Avicula gryphaeoides* is abundant in this glauconitic marl, and we have no doubt that this bed is identical with that found at the bottom of the boring at Stoke. We could not reach its base on account of the water which stands in the quarry; but the standing water testifies to the existence of impermeable clay below. Shouldham itself stands on the clay flat, which is, however, much narrower than at West Dereham.

This Glauconitic Marl is very similar to some varieties of the material which forms the basement-layer of the Chalk-marl near

Dunstable and Tring, beyond the southern termination of the Cambridge Greensand. In that district the basement-bed has a very variable composition, especially as regards the glauconitic ingredient—sometimes it resembles what is elsewhere called Upper Greensand, sometimes it is a laminated calcareous and micaceous silt without visible grains of glauconite. Everywhere, however, it is characterized by the presence of *Avicula gryphæoides*, and it occasionally contains small phosphatic nodules. The principal difference between specimens from Norfolk and Bedfordshire is that micaceous spangles are more obviously abundant in the latter, the Shouldham bed being lighter in colour, as if more purely calcareous.

Before passing to the sections north of Shouldham, we may call attention to the fact that the soft whitish marl which overlies the basement-bed in the Stoke boring appears to be absent at Shouldham, the hard buff-coloured chalk which is seen at the latter place resembling that which is 16 feet above the glauconitic marl at Stoke. This observation suggests the possibility of some 16 feet of the Chalk-marl having thinned out northwards, or having passed into a more purely calcareous and solid form; and we think this idea furnishes an explanation of the great changes which take place further north.

The outcrop of the Totternhoe Stone must emerge from beneath the Boulder-clay somewhere south of Fincham, and skirting the ridge below Fincham Mill, it doubtless runs along the slope which lies on the east side of the road to Marham. We did not notice any traces of the stone in this district, but subsequent experience in the country to the north would lead us to think the Totternhoe Stone would occur at Marham some 50 feet below the Melbourn Rock, which is exposed there, and consequently that its outcrop cannot be far from the church.

At the foot of Marham Hill a strong spring issues from an horizon which must be low down in the Chalk-marl, and a deep watercourse has been cut for the escaping water along the side of the road which leads to the Turf Fen. In this ditch, at a point somewhat less than a quarter of a mile west of the church, we found a bed of Glauconitic Marl, the microscopical examination of which proved it to be identical with that at Shouldham and in the boring at Stoke Ferry.

No important exposure of the Chalk-marl or Totternhoe Stone was seen for some miles north of Marham, but at Gayton, in a disused pit just west of the one in which lime is still burnt, the chalk at the base of the exposure is hard, greyish and gritty; and as it proved under the microscope to contain green grains, it is probably close to, if not actually the top of, the Totternhoe Stone.

The remarkable change in the lithological character of the Chalk-marl which we have shown to be gradually coming on as we progress northward is still more marked in the exposure in a pit about half a mile N.N.E. of Roydon Church (for section see p. 550).

The hard, grey-coloured, gritty chalk seen here has much of the character and appearance of Totternhoe Stone, for which it was taken by Mr. Whitaker. Beneath it is creamy-white material, very

hard, into which the dark-coloured gritty chalk above is let down by pipes or mottlings for a foot or more ; becoming more yellow towards the base, it passes into a grey-coloured marly clay, which contains *Belemnites*.

But the identification of this clay with the Gault, and the knowledge we have gained from the study of the beds at this horizon, both in this neighbourhood and further to the north, shows that the true stratigraphical position of the hard, grey, gritty chalk, with the 5 ft. of lighter-coloured material beneath it, must be at the base and not at the top of the Chalk-marl.

We have here a section analogous to that seen immediately above the Red Chalk in the cliffs at Hunstanton, viz. hard, creamy-white limestone overlain by grey and gritty chalk with a layer of green-coated nodules at its base, the so-called sponge- and *Inoceramus*-beds.

Though between this hard chalk and the Gault the glauconitic bed of Stoke Ferry and Shouldham appears to be wanting, yet the occurrence of *Avicula gryphæoides* at the base of the hard Chalk-marl, both here and in the Grimston brook, is a palæontological link which confirms our reading of the strata in this area. The lower part of the hard Chalk-marl seen in the banks of the brook at Grimston and at the Sow's Head spring has been described (see *ante*).

We recognize the equivalent of the Totternhoe Stone in an old pit three quarters of a mile N.E. of Sandringham Church. It is here a bed of hard, grey, gritty stone, $2\frac{1}{2}$ feet thick, with a layer of green-coated nodules at its base. Below it passes abruptly to hard creamy-white material, which we refer to the Chalk-marl. It is overlain by rather hard, dull, whitish chalk, the difference of colour in the chalk above and below the stone showing it in some relief.

A fine exposure of the lowest part of the Lower Chalk occurs in the parish pit of Dersingham, and was described by Dr. Barrois in 1876. Dr. Barrois*, however, never assigned to the Totternhoe Stone its true place in the series ; he at first supposed this stone to be on the horizon which we now call the Melbourn Rock, and subsequently he was led to regard it as belonging to the very lowest part of the Chalk-marl †. Consequently, when he visited Norfolk in 1875, he was quite unprepared to identify any representative of the Totternhoe Stone which might there exist. No geologist, however, excels Dr. Barrois in careful accuracy of observation, and accordingly we find him recording a layer of hard, rolled, yellowish or greenish nodules at a certain horizon both in the Dersingham and Hunstanton sections. This layer of greenish phosphatic nodules is identical with the "Brassil" of Cambridgeshire, and lies at the base of the band of grey rock which we identify with the Totternhoe Stone. At Dersingham it may be traced all round the pit, though the nodules are more abundant and the layer thus more evident in some places than in others. The band of compact grey chalk noticed by Dr. Barrois as occurring above this is the Totternhoe Stone.

* C. Barrois, "Recherches sur le Terrain Crétacé Supérieur de l'Angleterre et de l'Irlande," p. 160 (Mém. Soc. Géol. du Nord).

† See Ann. Soc. Géol. du Nord, tom. iii. p. 145.

Knowing that the base of the Chalk-marl could not be far beneath the floor, a boring was made to ascertain whether it rested on Gault or Red Chalk. Below is the complete section of this exposure combined with the results of the boring (fig. 4):—

Fig. 4.—*Diagram of the section shown and obtained by boring in the Dersingham Parish Chalk-pit.* (Scale $\frac{1}{8}$ inch to 1 foot.)

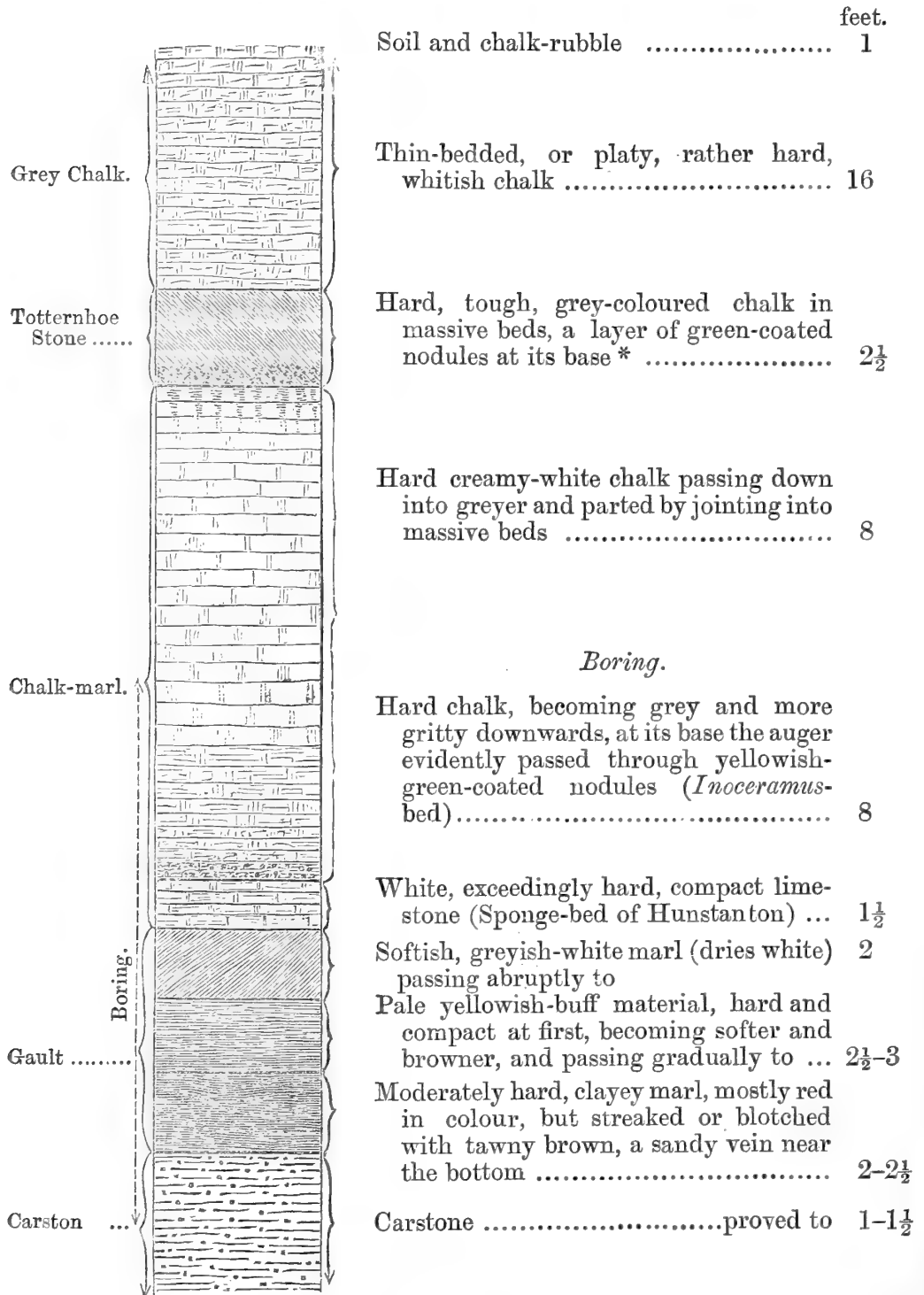

The section given by Dr. Barrois of this pit is very similar to our own, as follows:—

* Represented too thick in the cut.

	feet.
Compact whitish or greyish marly chalk with many fossils ...	12
Hard chalk with layer of nodules at base.....	3
Hard white chalk.....	1½
Hard greyish-white chalk, rather sandy	9

If the above section is compared with that of the Hunstanton cliff on page 562, the analogy between them is seen to be very striking. In both cases we have the same descending order of succession, viz. grey chalk, hard grey Totternhoe Stone with a layer of green-coated nodules at its base, overlying hard creamy-white Chalk-marl, which passes down into the greyer and more gritty *Inoceramus*-bed; beneath this the whiter and more compact sponge-bed rests in the one case on the Gault, and in the other on the Red Chalk.

The section shown in the pit about half a mile S.E. of the church at Snettisham is almost identical with the last, as follows:—

		feet.
	Soil and rubble	1
Grey Chalk.	Rather hard chalk, dull white weathering in platy layers.....	8
Totternhoe Stone.	Hard, greyish, massively bedded chalk, with an ill-defined layer of green-coated nodules at its base	2½
Chalk-marl.	Hard, creamy-white chalk passing down into greyer and more gritty material, the whole divided by jointing into massive beds	15

We again recognize as the Totternhoe Stone the massively bedded layer which is a prominent feature in the face of the pit.

At the large quarries at Heacham the Totternhoe Stone is again exposed as a bed of hard, grey, flaggy chalk with green-coated nodules at its base. If anything, the underlying Chalk-marl is of a purer white, showing up the darker grey stone in relief. Hardly so much of the marl below it is shown as in the preceding exposures; but its thickness cannot be great, for the outcrop of the Red Chalk is seen at the entrance of the pit. The pit is worked in two sections, an upper and lower; the whole, which shows a continuous section of the Lower Chalk, is given on page 570. The section of the lower part is:—

		feet.
	Soil	1
	Grey chalk	about 30
Totternhoe Stone.	Rather dark-grey, hard, gritty, chalk with green-coated nodules at its base	2
Chalk-marl.	Hard creamy-white Chalk-marl.....	seen for 12

The final exposure of the whole of the Chalk-marl, with the Totternhoe Stone and basal part of the Grey Chalk, can be seen in the cliffs at Hunstanton. The section (fig. 5) was taken a little to the north of the lighthouse.

The Totternhoe Stone is seen coming in with the gradual inclination of the beds a little to the south of the lighthouse. It forms a marked feature in the cliff face, its dark grey colour contrasting with the material above and below it. Except at one point it cannot be reached. Here the green-coated nodules can be seen at its base; they can also be detected in fallen blocks, which may be known by

their dark colour and by their compact, even, though somewhat gritty texture, compared with the rough unevenly sorted material of the *Inoceramus*-bed.

Fig. 5.—Section of Cliff near the Lighthouse at Hunstanton.
(Scale $\frac{1}{8}$ inch to 1 foot.)

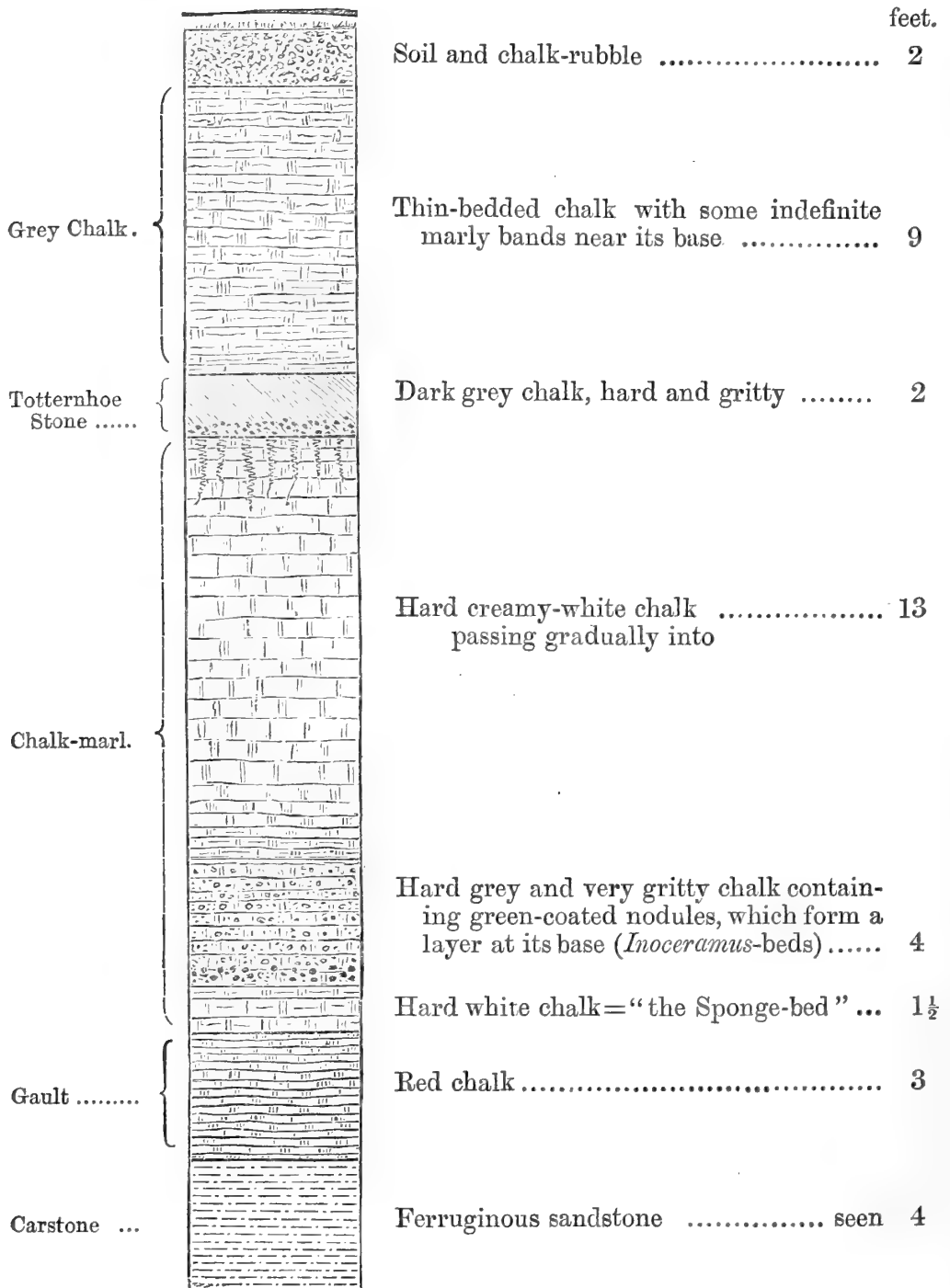

The Chalk-marl presents no different characters from those already described; it may be seen passing into the greyer and coarsely gritty *Inoceramus*-bed, which contains green-coated nodules, sparingly distributed at first, but forming a Brassil-like layer at its base.

As already mentioned, Dr. Barrois noted the occurrence of the

band of nodules beneath the Totternhoe Stone, but he failed to recognize the true horizon of the latter, correlating that stone and the overlying beds with his zone of *Belemnites plenus*. The list of fossils which he gives as obtained from these beds shows an assemblage which might have been obtained from the Totternhoe Stone of Burwell or Cherry Hinton.

In 1880 one of us suggested that the *Inoceramus*-beds might be the representative of the Totternhoe Stone, thinking that the whole of the Chalk-marl must have thinned out between Cambridge and Hunstanton, and not imagining that it could have passed into such hard chalk as that which forms the lower part of the Hunstanton section. The recognition of the Totternhoe Stone above the hard Chalk-marl of Stoke Ferry and the discovery of similar stone in a similar position at many intervening localities have, however, convinced us that the *Inoceramus*-beds lie below the real representative of the Totternhoe Stone.

The white nodular limestone (so-called Sponge-bed) which directly overlies the Red Chalk is about a foot and a half thick, and separates readily from the beds above and below; the inequalities between its under surface and the Red Rock are filled with a deep-red, nodular, ferruginous material, which Dr. Johnstone informs us consists largely of peroxide of iron. We think there can be little doubt that this white limestone is the same bed as that overlying the marly Upper Gault at Grimston, Roydon, and Dersingham, its character and thickness at the last-mentioned locality being just the same as at Hunstanton. The great importance of this identification has already been indicated (p. 552), and will be more fully discussed in the sequel.

The Red Rock below is certainly divisible into two portions or layers, if not into three, as under:—

3. Hard lumpy reddish chalk, or mottled red and white.
2. Rough, nodular, red limestone passing down into
1. Deep red gritty rock, softer at the base.

The commonest fossils in 1 and 2 are *Belemnites minimus* and *Terebratula biplicata*, in 3 *Exogyra Rauliniana* and broken shells of *Inocerami*. For further details respecting this well-known rock we may refer our readers to Mr. Wiltshire's paper (Quart. Journ. Geol. Soc. vol. xxv. p. 185).

C. *Zones of Holaster subglobosus, Belemnitella plena, and Rhynchonella Cuvieri.*

In Cambridgeshire the chalk which overlies the Totternhoe Stone presents the following succession in descending order:—

		feet.	
Base of	{	Rough, nodular, shelly chalk.....	40
Middle Chalk.		Sandy, yellowish, nodular rock in thick beds (Melbourn Rock).....	about 8
	{	Shaly marls enclosing band of hard white chalk (zone of <i>Bel. plena</i>).....	4
Lower Chalk.		Firm white chalk passing down into whitish chalk, which changes rapidly into next	50
		Grey chalk, blocky and fine-grained.....	30

Part of the above succession can be seen in the quarries at Swaffham Bulbeck, west of Newmarket, but there are no good exposures north of Newmarket. When the Bury and Soham railway was being made, in 1879, Mr. Whitaker recognized the Melbourn Rock and its underlying bands of shaly marl (zone of *Bel. plena*) in one of the cuttings south-west of Snailwell; and it is probable that the springs which rise below the church at Snailwell issue from the Melbourn Rock.

The outcrop of the Melbourn Rock is an important line to trace, because it fixes the uppermost limit of the Lower Chalk and the base of the Middle Chalk. It probably runs through Chippenham Park, and then passes beneath the great spread of valley-gravel which lies between Chippenham and Kennet; north of Kennet the country is covered by blown sand, but near Worlington-Heath farm there is a pit exposing the lower beds of the zone of *Rhynch. Cuvieri* and what seems to be the topmost bed of the rock itself. The section was as follows:—

	feet.
Gravelly soil and rubble.....	4
Hard, nodular, whitish rock in thin beds, full of <i>Inoceramus mytiloides</i> and <i>Rhynch. Cuvieri</i>	4
Thin seam of greenish-grey marl.	
Hard nodular rocky chalk, white with greenish matter between the lumps (no fossils)	3
Talus hiding chalk below	4

The beds appear to have a slight dip due east.

The gravel which forms such an extensive tract between Freskenham and Worlington seems to be banked against the ridge formed by the outcrop of the Melbourn Rock, and this will account for the sudden emergence of the Chalk from beneath the gravel plain. The rock is again seen in the cutting on the new railway to Mildenhall, just south of Worlington House, and it appears to have been formerly quarried by the side of the main road N.E. of that house.

On the north side of the river we could not find any trace of it, the large quarries at West Row being opened in the grey chalk, which here contains a remarkable band of reddish chalk; the details of this section have been given elsewhere*, and need not be repeated here.

Mildenhall itself stands on the hard, shelly, yellowish chalk of the zone of *Rhynchonella Cuvieri*, chalk of this description and containing that fossil together with *Inoceramus mytiloides* and *Echinoconus subrotundus* being exposed in a small pit at the east end of the town.

The chalk by the roadside, a mile and a quarter north-west of Mildenhall, appears to be the white blocky chalk which forms the upper portion of the zone of *Holaster subglobosus*, and the outcrop of the Melbourn Rock must therefore sweep round the western and northern sides of the town to the south end of the long inlet of fenland which runs by Eriswell. All the exposures which we could

* Bri. Assoc. Rep. 1886, and Geol. Mag. dec. iii. vol. iv. p. 24.

find along the eastern side of this fen are above the horizon of the rock; thus an old pit by the side of the main road, five furlongs S.E. of Eriswell Church, shows chalk with many fragments of *Inoceramus mytiloides*; this we regard as high up in the zone and consequently at some 30 feet above the base of the rock; the pit itself may be about 25 feet above the level of the fen, so that the outcrop of the rock is probably just at the edge of the fen near Eriswell, a position which it appears to hold for some distance northward, as far as Lakenheath.

The lowest exposure we could find near Eriswell was in a small pit about a mile north of that place, where we found hard chalk containing *Rhynchonella Cuvieri* and *Inoceramus mytiloides*; this cannot be far above the Rock. Beyond this the country is deeply covered with blown sand.

At Lakenheath, north-east of the church, there is an extensive quarry exposing about 30 feet of hard lumpy or nodular chalk which clearly belongs to the zone of *Rhynchonella Cuvieri*. It bears a striking resemblance to the chalk of the same zone exposed in the quarry and rail-cutting north of Goring in the valley of the Thames; the weathered faces present a rubbly appearance with large lumps of harder rock standing out here and there, but not forming any continuous bed; *Echinoconus subrotundus* was fairly common, but other fossils were not abundant except at the lowest level near the entrance, where harder and more regularly bedded nodular yellowish chalk is exposed, full of *Inoceramus mytiloides*, and like that which always overlies the Melbourn Rock. The workmen informed us that a few feet below the floor of this excavation they were stopped by water, so that here the rock appears to be below the level of the adjacent fenland, which is only about 300 yards from the entrance to the quarry.

More than two miles N.N.E. of Lakenheath and a little way south east of the railway-station there is a small pit close to the edge of the fen, which we did not visit, but in which Mr. Whitaker subsequently found *Inoceramus mytiloides* and *Echinoconus subrotundus*, so that it is doubtless in the same beds as the large quarry at Lakenheath.

Crossing the alluvium of the Brandon river we find ourselves on Lower Chalk, as already mentioned; and though the ridge above Hockwold is doubtless partly due to the outcrop of the Melbourn Rock, we could not discover any actual evidence of its existence, the only quarry near Hockwold (three furlongs north of the church) being in Grey Chalk.

On the Feltwell side this ridge sinks down into an undulating plateau, the natural features of which are masked by a drift of blown sand, and no pits have been opened along the course of the zone we have been following; but at Feltwell St. Mary, in a dry pond by the roadside, a quarter of a mile N.E. of the church, we found a small exposure of pink chalk weathering yellow and exactly like that of West Row; below it was a course of very hard nodular rock overlying soft whitish chalk, so that the agreement between the

two exposures is remarkable, although they are ten miles apart. We may fairly assume that this red band and its associated strata are continuous across the intervening space; and though we saw no traces of it further to the north, it is very likely to extend as far as Methwold, and might be discovered by a careful search over the fields west of that village.

At Methwold itself (south-east of the church) there is a large quarry nearly 40 feet deep and exposing the hard rocky chalk of the *Rhynchonella-Cuvieri* zone, overlain on the western side by about 12 feet of stratified sand and gravel. At the north end there is less gravel, and the section is as follows:—

	feet.
Soil, gravel and disturbed chalk	4
Hard lumpy chalk with two thin bands of greyish marl at the base	8
Hard, yellowish, nodular chalk with <i>Rhynch. Cuvieri</i> and other fossils	25
	—
	37

At the base a hole cleared of talus showed very hard, nodular, yellowish rock with fragments of *Inoceramus mytiloides*, which greatly resembled the upper part of the Melbourn Rock of Cambridge and Hertfordshire.

From this exposure it is evident that the outcrop of the Melbourn Rock runs not far to the westward of Methwold, and must sweep round into the valley which lies to the north of the village. Thence it runs north-westward towards Whittington, forming a well-marked ridge which crosses the main road about a mile south-east of Whittington; a little beyond this point and by the roadside is a quarry in hard, yellowish, nodular chalk like that seen at Methwold, and containing most of the same fossils.

To the north of Whittington is another quarry, which exposes the base of the Melbourn Rock and its junction with the underlying beds; the section is therefore of much importance, inasmuch as it is the first quarry in Norfolk exposing this horizon, and its distance from the last exposure of the zone of *Bel. plena* is not less than 20 miles. The beds exposed here are:—

	feet.
Gravelly soil and rubble.....	3 to 4
Hard, whitish, rough and rocky chalk, weathering into nodular lumps (Melbourn Rock)	7
Band of buff-coloured marl enclosing loose lumps or nodules of hard chalk.....	1½
Very hard, white, lumpy chalk, breaking with vertical joints (about 3 feet), passing down into hard blocky white chalk	15
	—
	about 27

The lowest beds have a greyish tinge, probably from moisture, but would doubtless dry white; these white blocky beds are comparable to the upper part of the Lower Chalk seen at Swaffham Prior and

Cherry Hinton in Cambridgeshire, but they pass up into a rock which is much harder and lumpier than any part of the Lower Chalk in Cambridgeshire. The overlying band of marl is doubtless the attenuated representative of the zone of *Belemnitella plena*, though its aspect is considerably different from that of its typical development. There is no clear separation into two layers, its upper surface is not so clearly defined as in Cambridgeshire, and its total thickness is very much less; the only fossils we could find in it were *Terebratula semiglobosa* and *Rhynchonella plicatilis*, the latter being abundant and the same variety of that species which is characteristic of the zone in Cambridgeshire and elsewhere.

The valley between Whittington and Stoke Ferry possibly coincides with a line of fault, for the ridge on the Stoke side, which should be a continuation of the Whittington outcrop, consists of Chalk-marl and Totternhoe Stone. The outcrop of the Melbourn Rock appears to be thrown back to the eastward, and emerges from under the alluvium near Oxborough, but little is seen of it for some distance. In an old pit by the roadside, near the windmill north of Oxborough Fen, we found lumps of hard yellowish chalk containing *Rhynchonella Cuvieri* and *Inoceramus mytiloides*, evidently belonging to chalk not far above the Melbourn Rock.

Thence there is a feature running northward along the border of Barton Fen, and then westward to a pit about half a mile south of Barton Bendish: here the base of the Melbourn Rock is again seen, together with some 30 feet of the underlying chalk. At the north-east corner the section is:—

	feet.
Thin soil, with hard nodular chalk below weathered into rough lumps	4
Yellowish, gritty, rough, and nodular chalk, passing down into whiter nodular chalk, which becomes soft and marly below.....	1½
Very hard, rough, white chalk (about 8 feet), passing down into greyish-white chalk, which breaks into blocks with a smoother fracture.....	12
Talus below.	

The west end of the quarry is entirely in the greyish chalk, which contains a hard rocky band; it is thick-bedded, and has a slight dip eastward. The marl band contained *Rhynchonella plicatilis*, as at Whittington.

At Marham lime-kiln, two miles further north, there is a similar section, showing about 5 feet of the Melbourn Rock overlying the yellow marly band; the rough white chalk below is so hard that it stands out prominently in the weathered face and overhangs the blocky greyish chalk into which its lower part passes. The yellow band at the base of the rock consists, in the upper part, of loose, yellow, rocky chalk, and in the lower of yellowish marly chalk and grey marl. At the north end of the quarry there is a marked band of hard nodular rock at the base of the hard white chalk; but this seems to disappear southwards.

A little north of this quarry are two cottages; and we are informed by the Rev. H. J. Sharpe, Vicar of Marham, that a well was sunk here some years ago to a depth of 85 feet, clay being touched at that depth and bored into for about 30 feet. The water-supply runs short in dry seasons, and is probably therefore derived from the Chalk, the bore not having been carried far enough to reach the Lower Greensand. As the cottages are very little below the level of the Melbourn Rock, we may estimate the thickness of the Grey Chalk, Totternhoe Stone, and Chalk-marl together here as about 90 feet, which is probably from 30 to 40 feet less than their combined thickness at Stoke Ferry.

Another large quarry at Marham, south-east of the church, shows an exact counterpart of the section at the first quarry, and calls for no especial remark.

From Marham the Melbourn Rock can be followed along the ridge on which its outcrop occurs, the rock itself being shown in one small exposure about two miles to the north of the preceding. Beyond this, though we are able to follow it by the character of the chalk and its contained fossils, the features usually formed by its outcrop may be said to be lost. The thinning-out and gradual hardening of the Lower Chalk in West Norfolk, as well as the severe glaciation to which this county must have been exposed, may account for this. The outcrop of the Grey Chalk is much hidden beneath Boulder-clay or spreads of gravel, but several good sections occur.

About a mile south-east of Narborough Station, hard rubbly chalk is seen in an excavation, made probably to obtain material for the railway. The exposure is much overgrown; but the character of the chalk indicated a close approach to the Rock.

In a pit half a mile south-east of Narborough church, hard whitish chalk, similar to that lying immediately below the Rock, was exposed.

Beyond the valley of the Nar are several pits in the chalk, but all above the Melbourn Rock; a little below them a slight ridge may possibly indicate its outcrop. We are able to identify it again in an old pit close by the church at Gaytonthorpe, hard, yellowish, nodular chalk, with a rough fracture, being exposed. A large Ammonite, closely resembling in form and state of preservation specimens from the Melbourn Rock of Hertfordshire and Cambridgeshire, was found here.

A good exposure of the lower part of the Grey Chalk occurs at Gayton. As is frequently the case in Norfolk, this pit is worked in two parts, an upper and lower, which, though separated by a considerable interval, yet form a continuous section. The chalk seen here is not of the same character throughout; it is rather darker grey at the base, and overlying this is a harder, more massively bedded layer, not unlike that lying beneath the Red Chalk at West Row. Above this the chalk is whiter, thinly bedded, weathering in thin platy or flaggy pieces.

The section is :—

	<i>Upper Pit.</i>	feet.
Soil and rubble		1
Thin-bedded, rather tough chalk, dull white		20
	<i>Lower Pit.</i>	
Rubble		1
Firm-bedded white chalk		12
Hard chalk, rather rough, parting along greenish marly lines, massively bedded		2½
Massively bedded, greyish, marly chalk		12

Beyond Gayton a slight ridge, more or less marked by spreads of gravel and nowhere a pronounced feature, continues; and near its summit, at Grimston, about half a mile south-east of the church, an old pit showed very hard and rough yellowish chalk at the top, with rather hard, but smooth, white chalk beneath it. Microscopical examination proves the hard yellow chalk to be the Melbourn Rock.

An excellent exposure of the upper part of the Grey Chalk occurs at Hillington, in a large pit in which the chalk is quarried for lime-burning. As usual, the pit is in two sections, which are as follows :—

	<i>Upper Pit.</i>	feet.
Soil and rubble-chalk		1
Thin-bedded, platy chalk, hard, and much stained with yellowish; a thin band of buff-coloured marl near the top.....		19
	<i>Lower Pit.</i>	
Whitish, thin-bedded chalk		4½
Thin, but persistently yellowish-buff marly band.		
Hard, massively bedded, whitish chalk		4
Bedded chalk, dull white, with greyer-coloured beds or bands		10

The chalk in the lower part of this pit divides into rather massive blocks along joints or veins of greenish-grey material, not unlike that seen in the partings of the Melbourn Rock. Overlying this, and a marked feature in the pit-face from its massive appearance and thick bedding, is a layer of whitish chalk, which breaks with a clean fracture, and is in appearance and structure like the firm white chalk which we have noted as underlying the Melbourn Rock at varying distances in Hertfordshire, Cambridgeshire, &c. The top of this exposure cannot be far below the Melbourn Rock. The higher thin band of buff-coloured marl may be the attenuated representative of the Belemnite-marls of Hertford and Cambridge.

In the railway-cutting just north of Hillington Station, hard, yellowish chalk, with rough fracture and full of fragments of *Inoceramus*-shells, was seen. This is probably just above the Rock; proceeding up the cutting, the chalk gradually became whiter, less shelly, and not so hard.

It may be noted here that, for a considerable thickness, the base of the Middle Chalk of Norfolk is extremely hard, a peculiarity which probably extends through the zone of *Rhynchonella Cuvieri*, as at Dover.

The outcrop of the Melbourn Rock probably follows the contour

of the wide transverse valley lying between Hillingdon and West Newton, at which place there are two good sections in the Grey Chalk, though they show nothing worthy of note.

A few feet of the base of the Grey Chalk may be seen overlying the Totternhoe Stone at Sandringham and Dersingham. A large pit in the central part of it occurs at Ingoldsthorpe, and its base is again seen in the pit at Snettisham.

Hard, yellowish, nodular chalk, but little above the Rock, is seen less than a quarter of a mile north of the church of Sherborne, in a small exposure by the roadside and just by an old quarry, the sides of which are now overgrown and its floor cultivated. Dr. Barrois says that in this quarry he could recognize the hard nodular bed (*i. e.* the Melbourn Rock) which throughout England occurs at the base of his zone of *Inoceramus labiatus*. His list of fossils gives those most common at this horizon.

The Melbourn Rock is well exposed in the upper part of the large quarry at Heacham. It is seen here as a very hard, yellowish, nodular rock, with rough fracture, massively bedded, and about six feet thick. *Rhynchonella Cuvieri*, *Echinoconus subrotundus*, and *E. castanea*, with *Inoceramus mytiloides*, occur.

It is much weathered, and splits along greenish marly veins in thin platy pieces, with a very rough, nodular, and uneven surface. The base is clearly marked, but it rests directly on hard white chalk without the intervention of a marl-band; there is, however, a thin layer of buff-coloured marl in the white chalk, about one foot below the base of the Melbourn Rock, and a second is seen near the top of the lower pit. These bands are similar to those at Hillingdon, where they probably occupy the same position with regard to the Rock as they are seen to do in this case.

The Lower Chalk weathers into thin platy pieces, with a more even surface and fracture, which contrasts with the rough nodular surface of the Melbourn Rock.

The entire section of both upper and lower pit is as follows:—

		<i>Upper Pit.</i>	feet.
Melbourn Rock.	}	Rough, thin-bedded chalk and soil	3
		Hard, yellowish, nodular rock, massively bedded	6
Grey Chalk.	}	Thin-bedded, hard, rather rough, whitish chalk in two courses, separated by a thin, buff-coloured, marly band .	2
		Thin-bedded, hard, whitish chalk; base obscured by talus	3-4
		<i>Lower Pit.</i>	
Totternhoe Stone.	}	Thin-bedded, platy chalk, becoming more massively bedded in its lower part, but not equally so; a marly band near the top	30
		Rather dark-grey gritty chalk, with green-coated nodules at its base	2
Chalk-marl.		Hard creamy-white chalk-marl	seen for 12

It will be seen, therefore, from the section given above of both the upper and lower parts of Heacham quarries, that, with the exception of two or three feet of Chalk-marl, the whole of the

Lower Chalk of North-west Norfolk is here exposed, and, like all the lower divisions of the Upper Cretaceous Series, it has thinned out, in a most remarkable manner, from about 150-160 feet at Cambridge to less than 60 feet at this point.

In the coombe a little to the north-east of the farm at Barret Ringstead there is a good exposure of the Melbourn Rock. It presents the same massive appearance as at Heacham. The section is:—

		feet.	
	Soil and hard rubbly broken chalk	6	
	Hard, rough, creamy-white chalk.....	3	
Melbourn Rock.	{	Very hard, rough, yellowish, nodular rock in two massive beds	7
		Thin-bedded chalk, dull white in colour, weathering into thin platy pieces.....	12
Grey Chalk.	{	More thickly bedded grey chalk	4

It only remains to note that 9 or 10 feet of Grey Chalk are shown above the Totternhoe Stone in the Hunstanton-cliff section (see p. 562).

§ 2. PALÆONTOLOGY.

TABLE I.—*Fossils of the Gault.*

The following is a tabulated list of the fossils we have collected from the Gault of West Norfolk, the last column showing how many of them have also been found in the Red Rock of Hunstanton:—

	Muzzle.	Dereham.	Roydon.	Grimston Brook.	Hunstanton Red Rock.
Pentacrinus Fittoni, <i>Aust.</i>	*	*
Terebratula bicipitata, <i>Sby.</i> (var. Du- templeana)	*	*	...	*	*
Kingena lima, <i>Defr.</i>	*	*
Ostrea vesicularis, <i>Lam.</i>	*	*	*
— curvirostris, <i>Nilss.</i>	*	*
— sp. (or <i>Exogyra</i>)	*	*
Plicatula pectinoides, <i>Sby.</i>	*	*	*
Inoceramus sulcatus, <i>Park.</i>	*	...	*	...	*
— concentricus, <i>Park.</i>	*	*	*	*	?
— — (var.)	*	*	
— Crippsii?, <i>Mant.</i>	*	*	*
Nucula pectinata, <i>Sby.</i>	*				
Aporrhais, sp.	*			
Ammonites interruptus, <i>Brug.</i>	*	*	*
— lautus, <i>Sby.</i>	*	*	*
— rostratus, <i>Sby.</i>	*	*	*
— varicosus?, <i>Mich.</i>	*	*	
Nautilus, sp.	*				
Belemnites minimus, <i>List.</i>	*	*	*	*	*
— attenuatus	*	*			
Fish-tooth.....	*				

It will be seen from this list that we succeeded in finding indubitable Gault fossils at the Muzzle pit, where Messrs. Reid and Sharman could not discover anything to convince themselves that the clay was not Chalk-marl. As already stated (p. 549), the specimens of *Ammonites interruptus* were mostly in the state of clay casts, a few only having their inner whorls preserved in phosphate, so that no doubt can exist about their being contemporaneous fossils; and this fact is of itself sufficient to decide the point at issue, even without the other characteristic Gault fossils which accompany them, viz. *Nucula pectinata*, *Inoceramus sulcatus*, and *Terebratula Dutempleana*. Of the other *Inocerami*, some seem certainly to be *I. concentricus*, and others resemble the larger and more compressed species which occurs frequently in the Lower Gault elsewhere, and may be identified with that known as *I. Crippsii* when found in the Red Chalk of Hunstanton.

With respect to the Dereham fossils our list is not so large as that given by Messrs. Reid and Sharman; but we protest against the elimination of the phosphatic specimens. Similar phosphatized fossils occur everywhere in the lower part of the Gault, often 20 feet above its base, as in Bedfordshire and Buckinghamshire. The state of the Ammonites with phosphatic centres at Muzzle shows why the phosphatic specimens are so often fragmentary; for if the beds in which such casts lay imbedded were afterwards subjected to the washing of a current, all the fine mud which composed the cast might be washed away and redeposited, leaving only the phosphatic portions *in situ*. It seems probable therefore that we may regard all such contemporaneous nodule-beds, which are frequent in the Gault, as the siftings of a certain thickness of clay which contained semiphosphatized and semiconsolidated casts of fossils. The rounded and broken appearance of the phosphatic fragments does not, then, necessarily show that they have been much rolled or waterworn, for they would present such an appearance as soon as they were detached from that portion of the cast which had not been filled with phosphatic matter.

Small oysters, resembling *Ostrea acutirostris*, Nilss., and *O. curvirostris*, Nilss., certainly occur; but most of those found by us come near to *O. curvirostris*, as figured by d'Orbigny, than to the broader shape of *O. acutirostris*; they differ, however, from the inflexed form of *O. curvirostris* which occurs in the Totternhoe Stone.

The fauna of the limestone beds seen in the Roydon cutting and in the Grimston brook remains to be considered; and, fortunately, the species and the state of their preservation are such that no doubt can possibly exist about the age of these beds. Lithologically, these limestone bands are exceedingly like the hard beds which occur in the Chalk-marl of Buckinghamshire and Oxfordshire; and had we not found the fossils above indicated, we might have felt very great hesitation about referring them to the Gault. Their lithological characters, however, can easily be explained, for a deep-sea formation of Gault age is not likely to resemble the Folkestone clay; whereas,

on the supposition that these beds are Chalk-marl, the occurrence of *Inoceramus sulcatus*, *I. concentricus*, *Ammonites lautus*, and *Am. rostratus* would be such an anomaly that, if anyone chooses to accept it, he must be prepared to renounce the stratigraphical axiom that "strata can be identified by their fossils."

We would apply the same reasoning to the Red Chalk of Hunstanton, where the same *Ammonites*, together with two others equally characteristic of the Gault, are found, and are associated with *Inoceramus sulcatus* and *I. Crippsii*. We do not think that any formation containing these fossils in an undervived state can be other than of Gault age, whatever the lithological character of the rock may be; and we feel sure that our friend Mr. Whitaker allowed lithological evidence to have too much weight and palæontological evidence far too little, when he mapped the Norfolk Gault as Chalk-marl and refused to see anything but chalk in the Red Rock of Hunstanton.

Mr. Whitaker has discussed the evidence of the fossils in his Address to the Geological Society of Norwich*; and he asks, "if the rock represent Gault and Gault only, how are we to account for the occurrence of the fossils belonging to higher beds, and some of which have nowhere been found in undoubted Gault?" This is a very fair question; but he seems to think that it is much more difficult to account for the appearance of species in any formation which have hitherto only been found in newer and higher beds, than it is to explain the occurrence of species which have only been found in older beds; we really cannot see why one case should be necessarily more difficult of explanation than the other: everything must depend upon the circumstances of the particular case.

In comparing the succession of faunas at places so far apart as Folkestone and Hunstanton, considerable allowance should be made for the possibility that some species may have come in at one locality before they reached the other; for it is quite certain that the conditions of life were very different at the two places—the sea-bottom in the one place was mud, and the water above was not very deep, while in the other place the bottom was a calcareo-ferruginous sediment, and the water was probably much deeper. This being so, it seems to us that the occurrence of a certain number of deep-sea (or Chalk species) is only what might be expected in the Hunstanton deposit. Two of these species, namely *Ostrea curvirostris* and *Terebratulina gracilis*, have already been found in the marly Gault of West Norfolk; and we are consequently led to expect that the other precursors of the Chalk-marl fauna of Southern England will be discovered in this deposit.

We would urge, therefore, in opposition to Mr. Gunn and Mr. Whitaker, that it is by no means the fossils "of the latest type that must be used in identifying the period" of the bed; but, on the contrary, that it is those of the earliest type that must be taken as

* Proc. Norwich Geol. Soc. vol. i. p. 230.

guides in this case, *unless it can be shown that they have been derived from an older stratum*. Mr. Whitaker suggests the possibility of their derivation, but frankly admits that he knows of no evidence in favour of it; neither do we, for the Gault species of the Red Rock seem to be in just the same state of preservation as the others.

The following statements were made by one of us when supplying Mr. Whitaker with a list of the fossils in the Red Rock of Hunstanton, and are quoted by him in the paper referred to:—"Palæontologically the Hunstanton Limestone has stronger affinities with the Gault than with any other formation," . . . "its affinities with the Chalk-marl are less strong: it must be remarked that none of the specially characteristic Chalk-marl species are found." Our recent researches have only strengthened the data on which these two statements were founded.

On reference to the list (Table I.), it will be seen that nearly all the fossils we have found in the Gault of Norfolk occur also in the Red Rock. Further, if we confine our attention to the Cephalopoda, which are usually regarded as the best guides in correlating strata of Secondary age, we find that no fewer than eight Ammonites, of characteristic Gault species, have been recorded from the Red Rock. These are:—*Ammonites auritus*, *Am. Beudanti*, *Am. interruptus*, *Am. lautus*, *Am. ochetonotus**, *Am. rostratus*, *Am. splendens*, and *Am. tuberculatus*. *Ammonites varians*, *Am. Coupei*, *Am. Mantelli*, *Am. navicularis*, and *Am. falcatus*, which are the characteristic Ammonites of the Chloritic Marl and the Chalk-marl, are conspicuously absent from the Red Rock.

The extreme rarity of Gasteropods in the Red Rock, while they are abundant in the Gault of Southern England, finds a natural explanation in the hypothesis that we are dealing with a deep-water fauna; for they are always rare in deep-water deposits, and at the present day their numbers always diminish with depth of water and distance from land, *Pleurotomaria* being the only genus that is now indicative of deep water.

* Recently found in the Lower Gault of Bucks, as have also all the other species, including *Am. rostratus*, which has hitherto been supposed to occur only in the Upper Gault.

TABLE II.—*Fossils of the Chalk-marl.*

	Basement-bed.		<i>Inoceramus</i> -beds.		Upper Beds.					
	Shouldham and Roydon, &c.	Hunstanton.	Roydon.	Hunstanton.	Stoke Ferry.	Dereham.	Dersingham.	Snettisham.	Hunstanton.	
SPONGIDA.										
<i>Plocoseyphia labrosa</i> , <i>Mant.</i>	*	*			
<i>Strephinia convoluta</i> , <i>Hinde</i>	*								
<i>Leptophragma Murchisoni</i> , <i>Goldf.</i>	*								
<i>Coscinopora</i> , sp.	*								
<i>Spongia</i> , sp.	*			
ECHINODERMATA.										
<i>Cidaris vesiculosa</i> , <i>Goldf.</i>	*	...	*						
— <i>dissimilis</i> , <i>Forbes</i>	?	...	B	B	
<i>Discoidea cylindrica</i> , <i>Lam.</i>	B						
<i>Holaster subglobosus</i> , <i>Leske</i>	*	...	*	*	..	*	..	*	
— <i>lævis</i> , <i>De Luc.</i>	B								
<i>Epiaster crassissimus</i> , <i>d' Orb.</i>	B						
<i>Pseudodiadema ornatum</i> , <i>Goldf.</i>	*						
— <i>variolare</i> , <i>Brongn.</i>	*						
ANNULOSA.										
<i>Serpula antiquata</i> ?, <i>Sby.</i>	*	...	*	*					
<i>Vermicularia umbonata</i> , <i>Sby.</i>	*	...	B						
<i>Pollicipes</i> , sp.	*	...	*						
BRACHIOPODA.										
<i>Terebratula buplicata</i> , <i>Sby.</i>	*	*	...	*	*	*	
— —, var. <i>obtusa</i> , <i>Sby.</i>	*	...	*						
— —, var. <i>faba</i> , <i>Sby.</i>	*	...	*						
— <i>semiglobosa</i> , <i>Sby.</i>	*	*	*	*	*	*	*	*	
— <i>subundata</i> , <i>Sby.</i>	*	...	*						
— <i>sulcifera</i> , <i>Morr.</i>	*	...	*						
<i>Kingena lima</i> , <i>Defr.</i>	*	...	*	*	
<i>Terebratulina gracilis</i> , <i>Schloth.</i>	*	*	*	*	
— —, var. <i>nodulosa</i> , <i>Eth.</i>	*	...							
— <i>striata</i> , <i>Wahl.</i>	*	...							
<i>Rhynchonella Cuvieri</i> , <i>d' Orb.</i>	?	*	*	*	
— <i>Grasiana</i> , <i>d' Orb.</i>	*	B	..	B	
— <i>Martini</i> , <i>Mant.</i>	*		
— —, var.	*	...							
— <i>Mantelliana</i> , <i>Sby.</i> (rare)	?	*	*	..	?	*	B	
PELECYPODA.										
<i>Ostrea vesicularis</i> , <i>Lam.</i>	*	*	*	..	*				
— <i>frons</i> , <i>Park.</i>	*						
<i>Pecten Beaveri</i> , <i>Sby.</i>	*						
— <i>elongatus</i> , <i>Lam.</i>	*						
— <i>fissicosta</i> , <i>Eth.</i>	*				
— <i>orbicularis</i> , <i>Sby.</i>	*	...	*	..	*				

TABLE II. (*continued*).

	Basement-bed.		<i>Inoceramus</i> -beds.		Upper Beds.				
	Shouldham and Roydon, &c.	Hunstanton.	Roydon.	Hunstanton.	Stoke Ferry.	Dereham.	Dersingham.	Snettisham.	Hunstanton.
PELECYPODA (<i>continued</i>).									
<i>Plicatula inflata</i> , <i>Sby.</i>	*	*	*	*	...	*	*	B
<i>Lima echinata</i> , <i>Eth.</i>	*	*	
<i>Avicula gryphæoides</i> , <i>Sby.</i>	*	*	...	*					
<i>Spondylus lineatus</i>	B					
— <i>striatus</i> , <i>Sby.</i>	*	...	*					
<i>Inoceramus latus</i> , <i>Mant.</i>	*	...	*	?	*	...	*	*
— <i>striatus</i> , <i>Mant.</i>	B
GASTEROPODA.									
<i>Pleurotomaria</i> , sp.	*	*
CEPHALOPODA.									
<i>Ammonites varians</i> , <i>Sby.</i>	*				
— <i>Mantelli</i> , <i>Sby.</i>	*			
— <i>Austeni</i> ?, <i>Sharpe</i>	*					
— <i>rhotomagensis</i> , <i>Brongn.</i>	*					
— sp. (small)	*	...	*					
<i>Turrilites</i> , sp.	*		
<i>Belemnitella ultima</i> , <i>Sharpe</i>	*	*	...	*					
FISH.									
<i>Otodus appendiculatus</i> , <i>Ag.</i>	*							

The letter B in the above list indicates that the species is quoted from Dr. Barrois's 'Recherches sur le Terrain Crétacé supérieur.'

As the lithological characters of the Chalk-marl exhibit a change in passing from Cambridgeshire into Norfolk, it is not surprising to find a corresponding change in the relative abundance of the fossils which occur in this subdivision. Thus in Cambridgeshire and the Midland counties, where the greater part of the Chalk-marl is really a marl, *Holaster subglobosus* is a very rare fossil, so rare that neither of us has yet found a specimen; in the "*Inoceramus*-beds" of Hunstanton it is exceedingly common, and it also occurs occasionally in the overlying beds below the Totternhoe Stone. Similarly *Lima echinata* which was first described from the Totternhoe Stone of Burwell, and has not yet been found in the Chalk-marl of Cambridge, becomes a common fossil where this Marl puts on the rough and rocky facies in West Norfolk, and is especially frequent in the *Inoceramus*-beds.

On the other hand, *Rhynchonella Martini*, which is such a common species in the Chalk-marl of more southern counties, becomes so

rare in Norfolk that we only found the typical form in the pit at Snettisham, that in the Hunstanton "sponge-bed" being a fine-ribbed variety, having some affinity with *Rh. lineolata*.

The same is the case with *Ammonites varians*, which is so common a fossil in the Chalk-marl of Reach and other Cambridge localities, and which is still abundant in the hard marl of Hockwold Grange, Suffolk. At Stoke Ferry it is a rare fossil, and beyond that place we did not meet with it at all except doubtfully at Hunstanton, neither is it recorded in Dr. Barrois's lists, so that if it does occur it is one of the rarest fossils at Hunstanton. The same may be said of *Ammonites Mantelli*, which is common in the Chalk-marl of the southern counties, but becomes rarer in going north.

It would appear in fact that the Ammonites were inhabitants of shallow waters, for while they swarm in the Gault, Upper Greensand, and Chalk-marl of the southern counties, they become gradually less abundant in the higher parts of the chalk of that region. Since therefore they also become much rarer both in the Gault and in the Chalk-marl as these divisions are traced northward, we may reasonably conclude that this rarity is due to the increase in the depth of the Cretaceous sea towards the north, an inference already drawn from other data.

We have to thank Mr. H. G. Fordham for the loan of the fossils which he collected recently from the Sponge-bed at Hunstanton; these have enabled us to give a fuller list than has hitherto been published. One of the commonest fossils in this bed is *Avicula gryphæoides*, which is so abundant in the basement-bed at Roydon and Shouldham and in the Cambridge Greensand; this species occurs rarely in the *Inoceramus*-beds, and we did not meet with it above that horizon.

Our thanks are also due to Dr. G. J. Hinde for naming the fragments of Sponges which Mr. Fordham had found.

TABLE III.—*Fossils of the Totternhoe Stone.*

	Isleham.	Stoke Ferry.	Sandringham.	Dersingham.	Snettisham.	Hunstanton.
ECHINODERMATA.						
<i>Holaster subglobosus</i> , <i>Leske</i>	*	*	*
<i>Discoidea cylindrica</i> , <i>Lam.</i>	*					
<i>Cidaris vesiculosa</i> , <i>Goldf.</i> (spines)	*
CRUSTACEA, &c.						
<i>Vermicularia umbonata</i> , <i>Sby.</i>	*					
<i>Pollicipes glaber</i> , <i>Röm.</i>	*	*				
<i>Scalpellum maximum</i> , <i>Sby.</i>	*					
<i>Glyphea cretacea</i> , <i>M'Coy</i>	*					
<i>Enoplocyrtia brevimana</i> , <i>M'Coy</i>	*					

TABLE III. (continued).

	Hunstanton.	Snettisham.	Dersingham.	Sandringham.	Stoke Ferry.	Isleham.
BRACHIOPODA.						
<i>Terebratula biplicata</i> , <i>Sby.</i>	*	*	..	*	*	*
— <i>sulcifera</i> , <i>Morr.</i>	*	*	*	*	*	*
— <i>semiglobosa</i> , <i>Sby.</i>	*	*	*
— <i>subundata</i> , <i>Sby.</i>	*	*	*
— <i>squamosa</i> , <i>Mant.</i>	*	*	*
<i>Kingena lima</i> , <i>Defr.</i>	*	*	..	*
<i>Terebratulina gracilis</i> (var. <i>nodulosa</i> , <i>Eth.</i>) ...	?	*	..	*
<i>Rhynchonella Mantelliana</i> , <i>Sby.</i>	*	*	*	*
PELECYPODA.						
<i>Avicula filata</i> , <i>Eth.</i>	*	
—, n. sp.	*		
<i>Ostrea vesicularis</i> , <i>Lam.</i>	*	*
<i>Pecten orbicularis</i> , <i>Sby.</i>	*	*	*	*	*	*
— <i>Beaveri</i> , <i>Sby.</i>	*	*	*
— <i>elongatus</i> , <i>Lam.</i>	*					
<i>Neithea quinquecostata</i> , <i>Sby.</i>	*					
<i>Plicatula inflata</i> , <i>Sby.</i>	*	*	*
<i>Teredo amphibæna</i> , <i>Goldf.</i>	*					
<i>Lima globosa</i> , <i>Sby.</i>	*	*				
<i>Inoceramus latus</i> , <i>Mant.</i>	*	*				
GASTEROPODA.						
<i>Pleurotomaria</i> , sp.	*
<i>Fusus</i> , sp.	*					
<i>Turbo</i> , sp.	*					
CEPHALOPODA.						
<i>Ammonites varians</i> , <i>Sby.</i>	?					
— <i>rhotomagensis</i> , <i>d'Orb.</i>	*					
<i>Turrilites costatus</i> ?, <i>Lam.</i>	*	*	
<i>Baculites</i> , sp.	*					
<i>Nautilus elegans</i> , <i>Sby.</i>	*					
— <i>Deslongchampsianus</i> , <i>d'Orb.</i>	*					
FISH.						
<i>Lamna</i> , sp.	*	*	
<i>Oxyrhina Mantelli</i> , <i>Ag.</i>	*					
<i>Saurocephalus striatus</i> , <i>Ag.</i>	*					

From the above list it will be seen that at Isleham the stone is nearly as fossiliferous as it is at Burwell and Cherry Hinton. The Isleham column has been filled up from three sources, (1) our own collections, (2) that of the Woodwardian Museum, (3) that of the Jernyn Street Museum, to which Isleham fossils were presented by Sir E. H. Bunbury.

From Isleham to Stoke Ferry is a distance of 18 miles, and at

Stoke the stone does not yield so many fossils, but then its diminished thickness must be taken into account. Its fauna in Norfolk does not offer any special peculiarities, and no doubt more prolonged search would greatly increase the number of fossils, and prove the assemblage to be the same as in Cambridgeshire.

TABLE IV.—*Fossils of the Grey Chalk.*

	Isleham.	West Row.	Whittington.	Stoke Ferry.	Barton Bendish.	Hillington.	By Prince of Wales Tower.	Dersingham.	Barret Ringstead.
<i>Serpula subtorquata</i>	B	
<i>Holaster subglobosus</i> , <i>Leske</i>	*	*	*	...	*	*
— <i>trecensis</i> , <i>Leym.</i>	*	...	*		
<i>Cidaris dissimilis</i> , <i>Forbes</i>	*	*	
— <i>Bowerbanki</i> , <i>Forbes</i>	*	*	...		
<i>Discoidea cylindrica</i> , <i>Lam.</i>	*	*	...	*	*
<i>Terebratula semiglobosa</i> , <i>Sby.</i>	*	*	*	*	*	*	*	
— <i>squamosa</i> , <i>Mant.</i>	*	
<i>Rhynchonella Grasiana</i> ?, <i>d' Orb.</i>	*	
— <i>Mantelliana</i> , <i>Sby.</i>	*	*	...	*		
<i>Kingena lima</i> , <i>DeFr.</i>	B	
<i>Terebratulina gracilis</i> , var. <i>nodulosa</i>	*	
<i>Ostrea vesicularis</i> , <i>Lam.</i>	*	B	*
<i>Pecten orbicularis</i> , <i>Sby.</i>	*	*	...		
<i>Exogyra haliotoidea</i> , <i>Sby.</i>	*		
<i>Plicatula inflata</i> , <i>Sby.</i>	B	
<i>Lima cenomanensis</i> ?, <i>d' Orb.</i>	B	
<i>Inoceramus mytiloides</i> , <i>Mant.</i>	*	...	*	...	*
<i>Ammonites lewesiensis</i> ?, <i>Mant.</i>	*	...	*	*		
— <i>Austeni</i> , <i>Sharpe</i>	*	*		
— <i>cenomanensis</i> , <i>d' Orb.</i>	*	...		
— <i>rhotomagensis</i> , <i>d' Orb.</i>	*		
— <i>planulatus</i> , <i>Sby.</i>	B	
<i>Belemnitella plena</i> , <i>Blainv.</i>	*		
Fish-scales	*		

The assemblage above recorded is such as might be found in the same subdivision further south, with the exception of *Belemnitella plena*. The occurrence of this species in the grey chalk of West Row near Mildenhall is a noteworthy fact, for it is its first recorded occurrence at such a distance below the Marls which form the zone of *Bel. plena*. The species from the Totternhoe Stone which has elsewhere been called *Bel. plena* is not that form, but the *Bel. lanceolata* of Sowerby (non Schlotheim).

The original example of *Peltastes Bunburyi*, Forbes, was obtained near Mildenhall by Sir E. H. Bunbury, and may therefore have come from the West Row pit.

The marls of the zone of *Belemnitella plena* in Norfolk have as yet yielded but two species, *Terebratula semiglobosa* and *Rhyn-*

chonella plicatilis; but as the bed is only exposed at three or four localities and is very thin, this paucity of fossils is not surprising.

The letter B in the Dersingham column means that the species so indicated are quoted from Dr. Barrois's list in his 'Recherches sur le Terrain Crétacé supérieur.'

TABLE V.—*Fossils of the Melbourn Rock and zone of R. Cuvieri.*

	Barret Ringstead.	Sedgford.	Heacham Pit and Cutting.	Hillington.	S.E. of Whittington.	Methwold.	Lakenheath.	Mildenhall.	Worlington.
<i>Cardiaster pygmæus</i> , Forbes	*			
<i>Hemiaster minimus</i> , Ag.	*			
<i>Echinoconus subrotundus</i> , Mant...	*	*	*	*	*	*	*	*	
— <i>castanea</i> , Brongn.	*						
<i>Discoidea minima</i> , Ag.	?								
<i>Cidaris</i> , sp. (spines)	*	...	*	*					
<i>Terebratula semiglobosa</i> , Sby.	*	*	*	*	*	*	*	*	*
<i>Rhynchonella Cuvieri</i> , d'Orb.	*	*	*	...	*	*	*	*	*
<i>Inoceramus mytiloides</i> , Mant.	*	*	*	...	*	*	*	..	*
<i>Ammonites peramplus</i> , Mant.	*	...	*	..	*		
— <i>Cunningtoni</i> ?, Sharpe	*	*		

The fossils on this zone, as might be expected from the constancy of its lithological characters, are the same as those which it contains in the Midland and Southern counties. The lower beds of the Melbourn Rock are, as usual, without fossils, but the upper beds and the shelly chalk above abound in *Rhynchonella Cuvieri* and *Inoceramus mytiloides*, while the echinid *Echinoconus subrotundus* is hardly less common above the Rock.

§ 3. REVIEW OF THE MINUTE STRUCTURE OF THE BEDS DESCRIBED IN THIS PAPER.

Gault.—The examination of specimens from various horizons of this formation, from Chatham Well-boring, Streatham Well, Arlesey, Tring, &c., shows them to consist in great part of inorganic material in an exceedingly fine state of division; on this acid has no effect, and it is negative under crossed nicols. An inconsiderable portion can be recognized as very fine quartz-sand, mica, grains of glauconite, and fragments of a fibrous material, probably of felspathic origin. Fragments of shell, Foraminiferal tests, and minute atoms which appear to be calcareous and disappear after acid, are present in varying proportions; but the deposit, as a whole, may be spoken of as inorganic.

The material composing the Upper Greensand which overlies the Gault in Buckinghamshire is in a much coarser condition, and the

examination of cores from a boring near Tring showed that there was a gradual passage extending through many feet from the coarse material of the Greensand to the finer material of the Upper Gault, a similar but more rapid passage to the Lower Greensand occurring at its base.

Proceeding along its outcrop to the north-east from Tring, the upper part of the Gault becomes more calcareous, and contains many Foraminifera, shell fragments and atoms of a calcareous nature, rendering it at Fancourt, near Harlington, almost comparable to certain parts of the Chalk-marl. But it is invariably separated from this formation by a Glauconitic Marl, a bed in which rather coarse grains of glauconite, quartz and mica flakes, with many shell-fragments, abound in a calcareous matrix, though the amount of its several ingredients varies somewhat with locality.

Proceeding still further to the N.E., we reach the incoming of the Cambridge Greensand dividing the Gault from the Chalk-marl, a bed marked by the abundance of large glauconitic grains, rather coarse quartz-sand, and some mica. At Arlesey this bed rests immediately on the Gault, which is not calcareous and agrees with that from its centre near Tring, there being no passage whatever.

We have had no opportunity for the examination of the material at the junction of the Gault and Cambridge Greensand between this point and Stoke Ferry, but at Stoke our boring passed through a bed in which green grains were abundant, and which also contained quartz and mica, and then entered abruptly into bright blue clay, which, though less calcareous than that at Fancourt, is more so than at Arlesey, and is probably Upper rather than Middle Gault. It forms a link between the latter and the still more calcareous deposit which we recognize as the Upper Gault further to the north-east.

The Lower Gault exposed at Muzzle and West Dereham is somewhat calcareous and contains many shell-fragments, &c.; it is, however, not unlike that from the lower part of the Tring boring, but there is a decrease of the coarser recognizable inorganic particles.

The examination of specimens from the railway-cutting north of Grimston station, from the brook sides, and from the boring at Roydon pit shows that the deposit which we recognize as the Gault has undergone considerable change.

That lying below the hard beds, while still containing much of the fine inorganic material, contains also a large proportion of shell-fragments and Foraminifera, and calcareous atoms derived probably from their decomposition. Glauconite appears to be absent, but there are a few quartz-grains sparingly distributed through the mass; some of these appear to be of greater size than those usually met with in the Central or Lower Gault, and may be derived in part from the underlying sands.

The hard beds seen both in the railway-cutting and elsewhere are alike in their structure. They appear to be entirely organic, and contain no quartz or glauconitic grains. Disunited or primordial cells of *Globigerina* or other Foraminifera form nearly 20 per cent. of their

mass, and shell-fragments, which often occur in small accumulations, about 8 or 10 per cent. more, the remainder being fine amorphous material. That part of the Gault above the hard beds, while still containing fine inorganic material, abounds in shell-fragments, Foraminifera, and calcareous atoms, the amount of the coarser fragments varying in different specimens. Recognizable particles of quartz are few and small, and grains of glauconite have not been detected at all.

The pink marl of the cutting and of the brook presents no important difference in structure from that described above.

The yellow and red beds passed through in the boring at Dersingham are alike in their structure. As in the Gault at Roydon, especially in that lying above the hard beds, organic material preponderates, single Foraminiferal cells, with some shell-fragments, forming no inconsiderable part of their mass. A few large grains of quartz-sand occur in the Red Clay, visible to the unassisted eye and comparable with those from the Carstone; smaller particles are not uncommon.

We have been unable to make a satisfactory section of the basal foot of the Red Chalk at Hunstanton; but above this the structure is much the same as that of the most calcareous Gault above described. Foraminiferal tests are perhaps in greater proportion, and there are indications of sponge-structure in the specimens examined. The upper part of the Red Chalk will, in fact, compare with the Red Clay of the Dersingham boring, with the more calcareous specimens of the Grimston Gault, and also with the hard beds, its chief difference being the greater amount of large quartz- and other mineral grains which it contains, and which have evidently been derived from the sands on which it lies.

The Glauconitic Marl found at the base of the Chalk-marl at Stoke Ferry has many points of resemblance both to the Cambridge Greensand and to the beds which lie at the base of the Chalk-marl in Bedfordshire. It is a calcareous marl, containing an abundance of glauconitic grains, with some mica-flakes and fine quartz-sand; and though these materials, particularly the glauconitic grains, are smaller and finer than in the Greensands of Bedford or Cambridge, the fact of their appearance in abundance at this horizon in a locality where such inorganic material is rare is most important.

The base of the Chalk-marl seen in the pit at Shouldham is a glauconitic bed, similar in all respects to that above described. This marl was again identified at Marham, beyond which it was lost. Above this bed, at Shouldham, the Chalk-marl, though hard, is not gritty, fine amorphous material forming a large proportion of its mass; single Foraminiferal cells are conspicuously abundant, and these with a few shell-fragments and entire Foraminifera constitute the remainder.

Chalk-marl.—Following the Chalk-marl, as we have done the Gault, we find that at Charlton, in Bedfordshire, it consists of a bluish grey clayey marl, with a recognizable amount of glauconitic grains, fine quartz-sand, and a proportion of the fine inorganic matter

similar to that of the Gault. But the quantity of shell-fragments, entire tests and disunited cells of Foraminifera, and calcareous atoms prove the marl to be mainly of organic origin, though at this point impurely so. At Charlton it passes up into a purely calc marl, yellowish-grey in colour, the tint becoming lighter with its increasing purity as a calcareous deposit.

Following the marl to the N.E., we find a gradual diminution in the amount of recognizable quartz-particles and gradually increasing purity from inorganic matter, till at Stoke Ferry hardly a trace of the bluer and most impure marl was noted in our boring, and the deposit, as a whole, appeared almost purely calcareous.

As previously mentioned, the upper part of the marl, at Feltwell, White Dyke, &c., increases in hardness. This is marked by an increase in the quantity of shell-fragments, principally prisms of *Inoceramus*-shells, which give it a gritty touch not unlike the Totternhoe Stone.

At Stoke Ferry layers of hard Chalk-marl, rendered gritty to the touch by the presence of many minute pieces of shell, and separated by layers of less shelly material, extend for some distance below the Totternhoe Stone. Below this, in the softer Chalk-marl, the amount of the coarser organic remains, such as shell-fragments and Foraminifera, is small compared with the proportion of amorphous material of which the Marl consists. Particles of quartz are to be found throughout it; grains of glauconite occur commonly in the top and lower portion, but are less abundant in specimens from the centre.

To this point every specimen of the Chalk-marl we examined contained minute grains of glauconite and quartz in varying proportions; beyond it the glauconite does not occur in the basement-bed, and is restricted to that part of the marl which we believe to be the equivalent of the *Inoceramus*-bed and to the Totternhoe Stone, while particles of quartz are few and small.

Thin sections of the hard creamy-white limestone which lies immediately above the Gault at Roydon and in the neighbourhood of Grimston show that this bed does not differ materially in its structure from the base of the marl above the glauconitic bed at Shouldham. Single Foraminiferal cells and more or less perfect tests of Foraminifera are conspicuously abundant; but these and a few shell-fragments form hardly 25 per cent. of the material. The so-called Sponge-bed at Hunstanton is comparable in all respects to the base of the Chalk-marl at Grimston and Roydon.

In the hard grey chalk above the creamy-white limestone at Roydon we find the gritty character of the Marl, which we have noted gradually increasing to the northward, still more marked. Here it closely resembles the Totternhoe Stone in appearance and structure, consisting of about 60 per cent. of coarse, irregularly sorted shell-fragments, mostly prisms of *Inoceramus*-shells; grains of glauconite are abundant, and the whole is set in a matrix of amorphous calcareous material. The green-coated nodules at its

base are not shelly, but agree in character with the underlying limestone.

This bed was certainly passed through in the boring at Dersingham, and at this place, as well as at Snettisham and Heacham, it gradually passes up into hard, white Chalk-marl, which, though less gritty, is full of shell-fragments and Foraminifera. The structure of the *Inoceramus*-bed at Hunstanton is almost identical with that of the hard, gritty chalk at Roydon. The shell-fragments are much coarser in its basal two or three feet, but it passes up into similar material and, finally, into the hard, white Chalk-marl, identical with that at Dersingham.

The Totternhoe Stone.—The beds usually referred to as the Totternhoe Stone vary a little in structure. That most in request for building-purposes, and which is quarried at Totternhoe and other places, and may be described as the typical stone, is seen, under the microscope, to consist of from 60 to 70 per cent. of shell-fragments, remarkably uniform in size, many glauconitic grains, which are frequently of large size and often in the form of beautifully perfect casts of Foraminifera, and a small percentage of fine quartz-sand. Both above and below the typical Totternhoe Stone are beds which present no such regularity in the assortment of the shell-fragments composing them, and the beds of the stone itself vary in thickness, and are often separated from one another by layers of less shelly chalk.

The “Brassil,” which underlies the Stone at Burwell, consists mainly of very coarse shell-fragments; but the green-coated nodules contained in it are not shelly, their microscopic structure being comparable with that of the Chalk-marl beneath.

At Isleham, Beck Row, and Stoke Ferry we are able to identify the Totternhoe Stone by its microscopical characters. It presents in all these exposures the same appearance as in specimens from the less defined beds of Hertfordshire and Cambridge, being rather irregular in grain.

At Sandringham, Dersingham, and all exposures beyond, the massively bedded layer at the top of the hard Chalk-marl possesses the same shelly character as its equivalent at the top of the Marl in Hertfordshire and Cambridge. Specimens from most of these exposures show some little irregularity in the size of the comminuted fragments of shell of which they are largely composed; but that from the cliff of Hunstanton is very like the upper part of the stone exposed in the Totternhoe quarries.

It must be added, however, that the fine quartz-sand, which at Totternhoe forms a part of its constituent material, is almost absent at Hunstanton. The gradual diminution in the proportion of this can be followed along the line of the outcrop of the Stone.

The Grey Chalk.—Above the Totternhoe Stone the change in the character of the deposit is usually abrupt, but not invariably so. Thin sections from the lower part of the Grey Chalk between Newmarket and Shouldham present exactly the same characters as those which we have before described in Cam-

bridge and Hertfordshire*. It consists almost entirely of fine amorphous material, with but few recognizable shell-fragments and Foraminifera; but north of Shouldham these become much more abundant, and the chalk assumes a firmer texture.

The hard white chalk previously referred to as underlying the Belemnite-marls closely resembles the white chalk with clean fracture noted by us † as occurring at varying distances below the Belemnite-marls of Hertfordshire and Cambridge. The single cells of Foraminifera increase in quantity, and it would appear that the change in the lithological character of the Chalk may be due to some extent to their presence. This bed was noted as far as Hillington, where it forms a marked feature in the pit-face; beyond this to the north it was lost.

Grains of glauconite, which are to be found in almost every specimen of the Chalk-marl, do not occur commonly in the Grey Chalk (except at particular horizons in certain beds, as the "Rag" of Bedfordshire); of nearly 150 specimens from this horizon alone, from various localities, only one contains them. Minute grains of quartz extend a little distance up into the Grey Chalk, where the passage between it and the Totternhoe Stone is not abrupt; the same remark will also apply to the grains of glauconite.

Melbourn Rock.—In thin sections this rock also presents the same characters through Suffolk and Norfolk that have already been described by us. Like that of Cambridge and Hertfordshire, it is full of fragmentary pieces or nodules of chalk, not unlike that which forms the top of the Grey Chalk beneath it, and these are imbedded in a matrix which frequently contains a large proportion of coarse shell-fragments.

There is also at this horizon a remarkable increase in the quantity of single Foraminiferal cells; in some of the less nodular and shelly specimens they are exceedingly abundant, and form a large part of the material of the Chalk.

Although these forms are often conspicuously abundant (see *ante*), there is no other horizon below the Chalk Rock where, so far as we know, they play so important a part in the formation of the Chalk. They are generally referred to as the disunited or primordial cells of Foraminifera; but it is singular that with their increase perfect forms do not become more abundant.

§ 4. CHEMICAL COMPOSITION OF THE GAULT AND CHALK-MARL.

By the kindness of Dr. W. Johnstone, F.G.S., and Mr. W. D. Severn, we are able to furnish some information concerning the chemical composition of the beds referable to the Gault and Chalk-marl in West Norfolk.

It has been stated (pp. 547, 549) that the marls which we refer to the Upper Gault, near Roydon and Grimston, are so calcareous as to have been mistaken by some geologists for Chalk-marl. The

* Quart. Journ. Geol. Soc. vol. xlii. p. 216.

† *Op. cit.*

following is an analysis made by Mr. W. D. Severn of the marl found at a depth of 5 feet in our boring at Roydon :—

Residue insoluble in HCl	25·55
Carbonate of lime	66·31
Alumina	3·33
Iron (as Fe ₂ O ₃)	·81
Magnesia	·46
Phosphoric acid	trace.
Moisture (at 100° C.)	1·85
	<hr/>
	98·31

The percentage of carbonate of lime in this sample is, undoubtedly, a very high one, and the marl is evidently far more calcareous than the Upper-Gault Marl of Folkestone, in which Mr. Hudleston found only 25 per cent. But it is obviously more logical to compare the Norfolk Marl with the Upper Gault of some more northern locality than Folkestone; and we have already mentioned the calcareous aspect of the Upper Gault of Bedfordshire, some of which has also been mistaken for Chalk-marl. We are indebted to Mr. Severn for the following analysis of a sample from Fancourt brickyard :—

Residue insol. in HCl, silica and silicates	38·21
Carbonate of lime	53·50
Alumina	3·90
Iron (as FeO)	2·00
Phosphoric acid	·09
Moisture (at 100° C.)	2·00
	<hr/>
	99·70

It will be seen that this marl contains twice as much carbonate of lime as that of Folkestone, and, consequently, that the proportion comes very much nearer to that in the Roydon marl—an approximation which strengthens the conclusion already arrived at, that the Norfolk marl is an actual northward continuation of the Bedford marl.

The following (A) is an analysis of the limestone which lies at the base of this marl in the Roydon cutting; it was made for us by Dr. W. Johnstone, and we have placed beside it an analysis by Prof. Way, of a hard bed in the Chalk-marl of Farnham (B), which has a very similar composition :—

	A.	B.
Insoluble residue (silicates, &c.) ..	6·64	7·26
Carbonate of lime	89·46	85·95
Sulphate of lime	1·32	·10
Carbonate of magnesia	·18	1·18
Potash and soda	—	1·47
Manganese	·40	—
Alumina	1·40	·20
Peroxide of iron	1·10	1·74
Soluble silica	—	2·11
	<hr/>	<hr/>
	100·50	100·01

Just as this limestone lithologically resembles the harder beds of the Chalk-marl, though it holds fossils which are characteristic of the Gault, so also there is a resemblance between the Roydon marls and the softer Chalk-marls of the south of England, as will be seen by comparing the analysis above given with the following (A being one by Prof. Voelcker, of a Wiltshire Chalk-marl*, B one by Prof. Way, of a soft marl, near Farnham, in Surrey†, and C by Mr. J. W. Knight, of the Chalk-marl at Horningsea near Cambridge):—

	A.	B.	C.
Insoluble residue (silica, &c.)	22·80	21·35	16·60
Soluble silica	2·16
Carbonate of lime	70·80	70·88	69·00
Carbonate of magnesia	1·72	·75	1·80
Sulphate of lime	2·65	·35
Potash and soda	traces	1·90	2·30
Alumina and iron	1·02	2·31	3·70
Organic matter and loss	1·00	6·60
	99·99	99·70	100·00

The proportion of carbonate of lime is a little larger than in the Roydon marl, but near enough for us to conclude that the latter was formed under such conditions of depth and distance from land as afterwards prevailed in the south of England during the formation of the Chalk-marl; consequently we may infer that the Gault sea in Norfolk was deeper and more distant from land than the Gault sea of the south and centre of England.

If we now compare the analyses of Chalk-marl, or even that of the harder and more calcareous bed at Farnham, with analyses of the beds at the base of the Chalk at Hunstanton, we shall see how much more calcareous the representative of the Chalk-marl becomes in Norfolk. The following analyses of (A) the “Sponge-bed” and (B) the *Inoceramus*-bed have been kindly placed at our disposal by Dr. W. Johnstone:—

	A.	B.
Insoluble silica	3·17	3·38
Lime	53·23	51·50
Carbonic acid	42·29	40·54
Phosphoric acid	·29	·16
Sulphuric acid	traces	·09
Alumina	·35	·35
Peroxide of iron	·32	·50
Manganese	traces	·47
Magnesia	·75	·25
Sodium chloride	traces	·75
Moisture and org. matter..	traces	1·40
	100·40	99·39

* Journ. Bath and W. of Engl. Soc. ser. 2, vol. vii. p. 240.

† Journ. Roy. Agric. Soc. vol. xii. p. 551. In this, after combining the magnesia, the sum of CO₂CaO has been taken as giving the amount of CaCO₃, though the amounts are not in strict theoretical proportion.

The amount of carbonate of lime in A may be taken as 95·5 per cent., and in B as 92 per cent.; for although the *Inoceramus*-bed is so gritty to the touch, it is really a pure limestone, and does not contain a larger quantity of silica than the compact limestone upon which it rests, its grittiness being entirely due to the angular fragments of hard *Inoceramus*-shell, of which it is so largely composed.

We were also desirous of knowing the chemical composition of the red marls, which occur at Grimston, Roydon, and Dersingham, and to see whether the last was more closely related in this respect to the Roydon marl or to the Red Chalk of Hunstanton. By the kindness of Dr. Johnstone, to whom we sent samples, we have been furnished with the following analyses of (A) the Grimston, (B) the Roydon, and (C) the Dersingham Marl:—

	A.	B.	C.
Silica and silicates	22·60	24·13	25·70
Carbonate of lime	69·50	64·46	64·49
Carbonate of magnesia	·90	·90	1·32
Sulphate of lime	·66	·36	·33
Peroxide of iron	3·40	6·00	4·16
Alumina and phosphoric acid	1·60	·90	·80
Manganese	trace	traces	traces
Organic matter, &c.	1·34	3·25	3·20
	100·00	100·00	100·00

It will be seen that the three are very similar in their composition, the marls from Roydon and Dersingham being almost identical, although the localities are more than four miles apart. A comparison of the above analyses with that of the overlying grey marl at Roydon (p. 586) shows that they may be regarded as the same marl, coloured red by peroxide of iron, the proportions of siliceous matters and carbonate of lime being almost the same, while the proportions of iron and alumina are in an inverse ratio.

They all differ from the Red Chalk, an analysis of which has been given by Mr. Wiltshire*; and the following is that of a pink sample from Hunstanton, by Dr. Johnstone:—

Silica, &c.	7·50
Carbonate of lime	83·81
Alumina	1·67
Peroxide of iron	5·72
Manganese	·58
Magnesia	·62
	99·90

This is, lithologically, a chalk; but its being so does not prove it to be stratigraphically Chalk, any more than the composition of the Roydon marl proves that to be Chalk-marl.

* Quart. Journ. Geol. Soc. vol. xxv. p. 185.

§ 5. FAULTS AND THE CHANGE OF STRIKE.

Prof. Judd has called attention to the frequency of cross faults in the district where a change of strike takes place*. Such is the case in the north of Gloucestershire, where the Jurassic escarpment changes its strike from a northerly to a north-easterly direction, and, again, in Rutland, where it resumes a northerly strike.

The same phenomenon is exhibited in the district we have described, where the Chalk escarpment changes its direction from north-east to north; but the faults are much less easily detected, because there are no sharp contrasts in the lithological characters of the beds, like those which exist among the Jurassic rocks, and it is only when a definite horizon, like that of the Melbourn Rock, is followed across the country that anything like good evidence is obtained of the existence of such faults.

At West Row, near Mildenhall, a small fault is seen in section; but its throw is small, and as we were not able to trace the outcrop of the Melbourn Rock round Mildenhall, we cannot say whether there are others; but the change of strike certainly begins here.

We feel sure that an important fault is hidden beneath the alluvium of the Brandon river, for, as already stated (p. 565), the horizon of the Melbourn Rock, near Lakenheath Station, is at or below the fen-level, whereas on the northern side of the valley, near Hockwold, it is 40 or 50 feet above the alluvium, and the Lower Chalk forms a prominent ridge which extends westward from Hockwold for a distance of about two miles. There must therefore be an east and west fault, with an upthrow on the north side.

We also think that there are two parallel faults near Feltwell, between which a narrow block is thrown up, so that the outcrops are shifted eastward for a space, but resume their normal position to the north of Feltwell. This inference, however, depends entirely on the correctness of our supposition that the beds exposed in the old lime-kiln south of Feltwell belong to the Chalk-marl.

From Feltwell the outcrops appear to be continuous as far as Whittington, the strike being nearly due north, and the beds having a slight inclination in the direction of the strike, so that at Whittington the Melbourn Rock is not so far above the level of the fen as it is at Hockwold and Feltwell. On crossing the Stoke river we find the Totternhoe Stone at a somewhat higher level than that of the Melbourn Rock at Whittington, and as the outcrop of the Lower Chalk here runs north-west for some miles, it looks at first sight as if there were a fault bringing up the lower beds on the N.W. side of the valley; but it is probable that the real strike is still nearly due north and south, and it will be seen that a line connecting the outcrops of the Melbourn Rock at Whittington and Marham would not deviate much from this direction. There may be a fault with a northerly upthrow, but there is no clear evidence of its existence.

* "Geology of Rutland," Mem. Geol. Surv.

There can be little doubt, however, that Stoke is the centre of a shallow syncline (whether faulted or not), and that just as the beds fell northwards along the strike to Whittington, so beyond that place they rise northward to Marham, where the Melbourn Rock attains a high elevation without being much in advance of the line of strike. This northerly rise will account for the emergence of the Gault and Lower Greensand from beneath the fen, and it will also explain the carrying back of the outcrops so far eastward by the valley of the Nar, which would otherwise seem to require the agency of a fault.

North of Marham and Narborough it is possible that the level of the base of the chalk still continues to rise; but if so, the diminution in the thickness of the Lower Chalk keeps the normal level of the Melbourn Rock nearly horizontal; for though we do not possess accurate information, the height of its outcrop at Marham and at Hunstanton appears to be nearly the same, and these two places are, we think, about on the true line of strike, viz. a north and south line, without any appreciable trend to the west, such as would appear if the line from Narford to Hunstanton were taken to be the true line of strike.

Thus the district we have described may be regarded, geometrically, as consisting of three portions or blocks, the first extending from Mildenhall to the Brandon river, the second from that river to the Stoke river, and the third from Stoke to Hunstanton. The first two of these blocks have received a slight tilt to the north, so that the beds rise along the strike southwards, the third has an inclination in an opposite direction.

It is evident that these faults and tiltings have a considerable effect upon the surface-contours of the country, and it seems probable also that the tilting of the first two blocks has a connexion with the change of strike. In seeking for the cause of this change, we must ask ourselves which is likely to have been the original strike, the northerly strike of Norfolk, or the north-easterly strike of the Midland counties? We think there can be little doubt that the former was the original strike, imparted to the Cretaceous rocks by the upheaval at the close of that period, and that the north-easterly strike was the direction given to the escarpment by the disturbances which produced the London and Hampshire basins. In other words, we hold that the influence of the synclinal curvature of the London basin does not extend beyond the latitude of Mildenhall, and that north of this the original strike of the Cretaceous rocks is preserved with little alteration, and has not been affected by the disturbances above mentioned.

§ 6. SUMMARY AND INFERENCES.

Gault.—With respect to the Gault we claim to have established the following facts:—

1. That the Gault can be traced through Norfolk from Stoke Ferry to Dersingham, where it thins out.
2. That it is divisible into an upper and a lower portion, and

that it contains a peculiar layer of reddish marl or clay, which remains as a basement-bed after the more Gault-like material has thinned out.

3. That the Norfolk Gault, as a whole, is much more calcareous than the Midland Gault, and that its upper portion cannot be called a clay, but is a light-grey chalky marl, with occasional layers of yellowish-grey limestone.

4. That the fossils of these limestone bands decide the real age of the beds.

5. That microscopical examination shows a decreasing amount of inorganic matter (quartz, mica, and felspar) as the beds are traced northward, with an increasing proportion of organic material (Foraminifera and shell-fragments), which becomes very large in the Roydon and Grimston Marls.

6. That there is an entire absence of anything comparable to the malmstones, ragstones, or glauconitic sands of the so-called Upper Greensand.

The increasing amount of calcareous matter in the Gault as it is traced northward through Norfolk is, we consider, a fact of much importance. It is evident that in passing from Dorsetshire to Norfolk we travel further and further away from the source of the mechanical sediment, and get nearer to oceanic conditions. The quartzose sands of the so-called Upper Greensand appear to die out in North Wiltshire or in Berkshire, the malmstones die out in Buckinghamshire, and marly clays of the Upper Gault take their place to the northward; in Bedfordshire this Upper Gault is very calcareous, and it is still more so in Norfolk, where the Lower Gault also becomes calcareous, and the whole formation gradually passes into a thin calcareous deposit.

Just as the upward succession of the Gault clays at Folkestone from the dark-blue pyritous clay of the Lower Gault to the light-grey marly clay of the Upper Gault, indicates in all probability a deepening of the sea in which they were deposited, so the lateral passage from the argillaceous Gault of Bedford and Cambridge to the marly clays of West Norfolk means an increasing depth of water and distance from land in this direction.

These considerations are, in our opinion, quite sufficient to explain why the Upper Gault in the centre of West Norfolk bears so great a resemblance to Chalk-marl, and why it contains layers of limestone and red clay.

This chalky marl is, in fact, the deep-water representative of the Upper Gault and so much of the Upper Greensand as can be shown to be the equivalent of the Upper Gault.

Chalk-marl.—With respect to the Chalk-marl itself, we may summarize our results as follows:—

1. That it maintains its average thickness as far as Stoke Ferry, but then thins rapidly northward, and decreases to 18 feet at Hunstanton.

2. That its lithological characters alter, the upper part becoming harder and whiter before it begins to thin; hard beds also make

their appearance below, and the marly beds thin out, till at and beyond Grimston the whole division consists of hard chalk.

3. That for a certain distance its basement-bed is a glauconitic marl, but that this thins out beyond Marham, and the overlying bed of hard white limestone then forms its basal layer.

4. That microscopical examination shows that the proportion of Foraminifera and recognizable shell-fragments increases as the beds are followed northward, and that the hard beds of north-west Norfolk may be regarded as the condensed equivalent of the true Chalk-marl, differing from it by the greatly reduced amount of inorganic matter and of glauconite grains.

Red Chalk.—We are now in a position to indicate the bearing of our work on the debated question of the exact age of the Red Chalk. In the absence of anything like ordinary Gault, Upper Greensand, or Chalk-marl at Hunstanton, the remarkable stratum which there lies at the base of the Chalk has been referred by different observers to each of the formations which appeared to be missing—to the Gault by most of the earlier writers and by Mr. Wiltshire, to the Upper Greensand by Prof. Seeley (on the strength of its fossils being similar to those of the Cambridge Greensand), and, lastly, to the Chalk-marl by Mr. Whitaker. Everyone, however, has discussed the question principally from a local point of view, founding their arguments mainly upon a consideration of the rock and its fossils as seen at Hunstanton. It is true that Mr. C. B. Rose and Mr. Wiltshire both obtained some items of stratigraphical evidence, but they were rather meagre, while the value of Mr. Whitaker's remarks is diminished by his having then mistaken the Upper Gault of Norfolk for Chalk-marl.

It was evident, therefore, that the problem could only be solved by following up the component beds of the Gault and Chalk-marl from an area in which they were more normally developed. Such stratigraphical work, however, was by no means easy; for these strata form a low-lying tract of country, where natural or artificial exposures are few, and where they are often concealed by spreads of Boulder-clay and gravel. We think, however, that the borings we have made, and the facts we have observed, are sufficient to determine the stratigraphical relations of the beds we are discussing.

As already stated, we have ascertained that in Norfolk there is a complete but rapid or sudden transition from Upper Gault to Chalk-marl, without the intervention of any quartzose or glauconitic sands; but we would point out that these are not exceptional relations, and that the Stoke and Shouldham sections may almost be matched near Ivinghoe in Buckinghamshire and Totternhoe in Bedfordshire. At both these places there is an entire absence of anything which can truly be called Upper Greensand, and there is a complete passage from marly Gault into Chalk-marl, the passage-bed being a dark-grey marl with many spangles of mica and small grains of glauconite. The explanation of this passage is that the sands and rock-beds of the so-called Upper Greensand have been gradually replaced by the marls of the Upper Gault, while the green glauconitic marls seem

to have thinned out, so that there is a direct transition from the Gault-marl to the Chalk-marl. It is hardly too much to say that the structure of the Totternhoe district affords the key to that of West Norfolk, because it explains that passage from Gault to Chalk which has been such a puzzle to those who have examined the Norfolk sections. It is now evident that such a complete transition from one formation to the other is the normal condition of things in that part of England which lies to the north-east of Buckinghamshire.

This being so, we are completely relieved from the necessity of finding an equivalent of the Upper Greensand as distinct from the Upper Gault in the Hunstanton section, and it only remains to decide whether the Red Rock in that section is the equivalent of the Norfolk Gault or of the Norfolk Chalk-marl. This question seems to find a decisive answer in the following considerations:—

1. That the Norfolk Gault becomes increasingly calcareous towards the north, till at Dersingham it passes into 7 feet of marly and chalky material, the lower portion of which is coloured red.

2. That the microscopical structure of the Hunstanton rock bears the same relation to the red and yellow marls of Dersingham that the hard Chalk-marl of Norfolk does to the softer Chalk-marl of Cambridgeshire.

3. That the hard whitish limestone which overlies the representative of the Gault from Grimston to Dersingham is identical, in our opinion, with the so-called "sponge-bed" which overlies the Red Rock at Hunstanton.

4. That the fossils are chiefly Gault species, and are such as would constitute a deep-sea fauna contemporaneous with that of the shallower and muddier water in which the Gault of South England was formed.

From these premises we come to the inevitable conclusion that the Red Rock of Hunstanton must be the equivalent of the Gault, and not of its upper division only, but that it is a condensed representative of both Lower and Upper Gault, formed outside the limits of the area reached by mud-bearing currents.

Cambridge Greensand.—It has been stated above that the transition from Gault to Chalk-marl must be regarded as the normal state of things in the counties of Bedford, Hertford, Cambridge, Suffolk, and Norfolk. Now it is true that, over a large part of this area, there is no such transition, but, on the contrary, a plane of erosion between the two formations, and a nodule-bed at the base of the Chalk-marl, containing fossils and phosphates derived from the Gault. But this must be regarded as an abnormal condition of things; as explained by one of us twelve years ago*, the Hertford and Cambridge area was part of a tract of the sea-bottom which was invaded by rapid currents, and over this tract a certain portion of the Gault was sifted and swept away. In the south of England the interval is represented by certain glauconitic sands and marls; but in Norfolk there seems to have been simply an absence of deposition,

* Jukes-Browne on "The Relations of the Cambridge Gault and Greensand." *Quart. Journ. Geol. Soc.* vol. xxxi. p. 256 *et seq.*

the interval being here marked by the sudden change from Gault to Chalk-marl, and from "Red Rock" to white limestone.

The diagram, fig. 6, is drawn with the view of illustrating the normal succession in the counties referred to, and the manner in which this is broken by the erosion of the upper part of the Gault over a certain space. From this it will be seen that we are presented, as it were, with the two ends of the stratigraphical chain, and that, in the interval between Totternhoe and Stoke Ferry, the total thickness of the Gault has diminished from about 230 feet to 60, the difference, 170 feet, being entirely the result of thinning-out. The additional information which has been obtained since the publication of the paper on "The Relations of the Cambridge Gault and Greensand," makes it now possible to estimate more accurately the width of the area over which erosion took place, and the maximum amount of the Gault which was removed from the central portion of this area.

In the first place we must point out that, though there is a steady decrease in the total thickness of the Gault, yet between Tring and Hitchin there would appear to be an increase in the thickness of the Lower Gault from 150 to 204 feet, so that if the Upper Gault had maintained the thickness it presents near Tring, namely, 80 feet, the formation would have had a thickness of at least 284 feet near Hitchin and Arlesey. There is, however, good reason to believe that the Upper Gault becomes rapidly thinner as it is traced northward, and could never have been more than 20 or 30 feet thick at Hitchin, so that the original thickness of the Gault there was probably about the same as near Tring, though the relative thicknesses of the two subdivisions were different.

North of Arlesey the Lower Gault diminishes in thickness, and it is assumed that this is mainly due to the erosion it has undergone; it is not improbable, however, that this division attained its greatest thickness at or near Arlesey, and that it thinned northward as rapidly as it did and does to the southward. On this supposition it would have had a thickness of 150 feet at Cambridge, and to this must be added a certain thickness (say 20 feet) for the Upper Gault.

The diagram, fig. 7, shows the actual surface of the Gault between Cheddington (near Tring) and Dersingham in Norfolk, and the broken lines show what we suppose to have been the original surfaces of the Lower and Upper Gault respectively. From Arlesey to Cambridge these are drawn in accordance with the inference that the Gault was originally 170 feet thick at the latter place, and, as we believe that the Gault at Stoke Ferry has not suffered from erosion, the diagram is easily completed by joining the lines between Cambridge and Stoke. It will be seen that the slope thus obtained agrees very nearly with that of the actual surface between Stoke and Dersingham.

If the data on which this diagram is founded are correct, the maximum amount of Gault removed from any part of the eroded area appears to be 50 feet. The base of the Gault is drawn as a

Fig. 6.—Diagram showing the alternation of Gault and Lower Chalk between Cambridge and Hunstanton.
 (Horizontal scale 8 miles to 1 inch.)

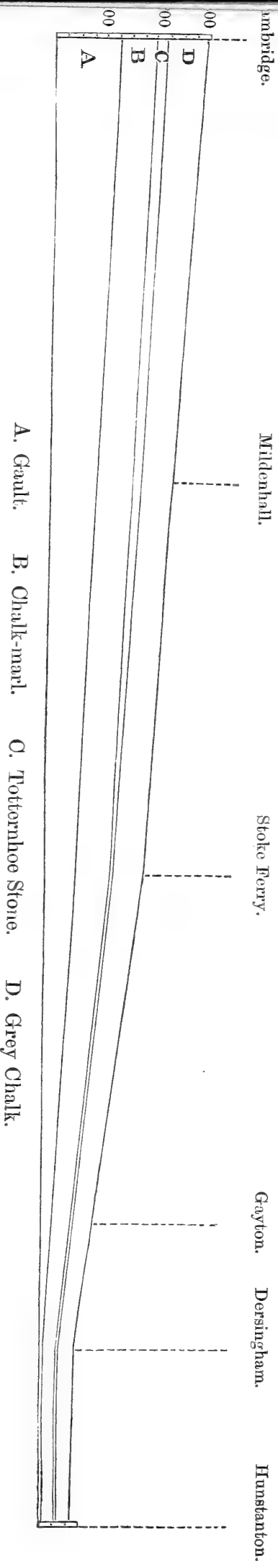
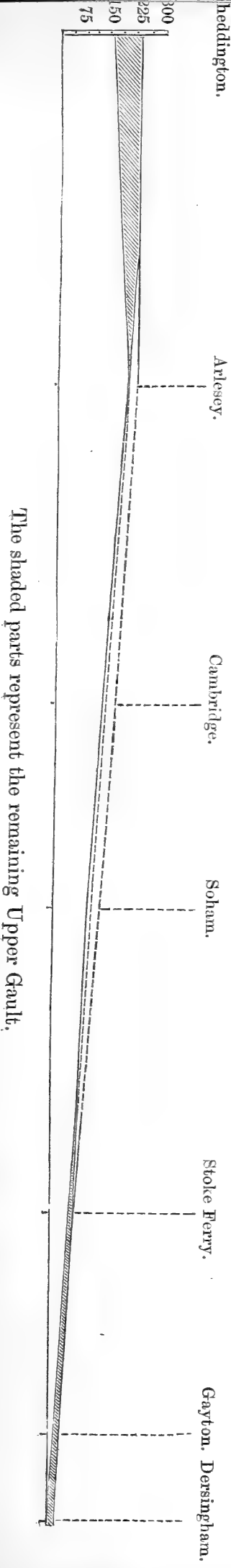

Fig. 7.—Diagram to show the thinning out of the Gault and amount lost by Erosion.
 (Horizontal scale 12 miles to 1 inch.)



The shaded parts represent the remaining Upper Gault.

horizontal line, but it would not make any difference to this calculation if it were a curved one. It is quite possible that the Gault below Arlesey fills up a hollow in the surface of the Lower Greensand, and that its upper surface is nearly level, but the thicknesses would of course remain the same.

It might be said that the assumed thickness of the Gault at Cambridge (170 feet) is too great, and that the Lower Gault may have thinned out more rapidly northward of Arlesey than it does southward; but we reply that on the other hand it may have continued to thicken for some distance north of Arlesey, for we have no real evidence to the contrary. We think that, considering all the circumstances, the thickness we have assigned is a reasonable one, and that the projection as shown in the diagram has a more natural appearance than if the original thickness at Cambridge were taken to be less.

A further inference may be drawn from this diagram, for if it is a fairly accurate representation of the facts, it will enable us to predicate the probable limit of the Cambridge Greensand in a northerly direction. This will be indicated by the point where the line representing the original slope of the Gault meets the line representing its present surface; now the prolongation of the present slope north of Soham meets the line for the base of the Upper Gault at a point about seven miles south of Stoke Ferry, and hence it may be expected that the Cambridge Coprolite-bed will be found to extend beneath the fens to this point, or at any rate for a distance of 10 miles beyond Soham. It is probable that the number of derived nodules and fossils diminished gradually to the northward, and that the bed passes gradually into the glauconitic marl of Stoke Ferry: and further, since we found a derived phosphatic specimen of *Avicula gryphæoides* in that marl, it is evident that Stoke cannot be far beyond the limits of the eroded area.

Totternhoe Stone.—The stratigraphical importance of this band lies chiefly in its affording the means of fixing the upper limit of the Chalk-marl; for if this stone had not been recognizable, it would have been very difficult to draw any line between the Grey Chalk and the still harder chalk representing the Chalk-marl; but, as a consequence of tracing this stone through the west of Norfolk, we were able to recognize the horizon in the Hunstanton cliffs, and thus to give a more satisfactory reading of that section than any which has hitherto been proposed.

The Totternhoe Stone partakes in the universal attenuation of the Lower-Chalk strata in West Norfolk, diminishing from 20 feet at Burwell to 4 feet at Stoke Ferry, and 2 feet at Hunstanton, but its lithological characters undergo very little alteration.

Grey Chalk.—It is interesting to observe that the chalk overlying the Totternhoe Stone exhibits the same separation into a lower grey and an upper white portion that we have observed in this division elsewhere; the characters of the upper white portion are, indeed, more distinctly marked than they are further south, the rock being so much harder than the underlying grey chalk that in old

pits it has a tendency to form an overhanging cornice. In thickness this part of the Lower Chalk diminishes from about 80 feet near Newmarket to about 35 feet near Hunstanton.

Belemnite Marls.—The component strata of this zone are so persistent in the midland counties that we were not prepared to find such a difference in the Norfolk sections, and, in the absence of any exposures between Snailwell and Whittington, we can only say that a great change takes place in the interval, and that this change is in harmony with those exhibited by the other beds. It consists in a diminution in the amount of the muddy ingredient, and this condensation continues till, in the north of Norfolk, the marly element is almost eliminated, so that in the absence of fossil evidence it becomes impossible to recognize the horizon.

The Melbourn Rock, which forms the base of the zone of *Rhynchonella Cuvieri* and of the Middle Chalk, presents substantially the same characters as it possesses in the counties of Cambridge and Hertford. It is evident that at this time deep-sea conditions prevailed over the whole area, consequent perhaps upon an acceleration in the rate of subsidence, so that a deposit of the same kind of sediment was formed over a large area.

In conclusion, we would point out that the total amount of diminution in the thickness of the Lower Chalk between Newmarket and Hunstanton is 115 feet, being the difference between 170 feet at Newmarket and 55 feet near Hunstanton. In spite, however, of the reduced thickness of the Lower Chalk in West Norfolk, we have found that its zonal divisions can be brought into harmony with those which have been established in the midland and southern counties.

This having been done, we now possess a surer basis for the study of the Lower Chalk of Lincolnshire, which is known to be generally similar to that of West Norfolk. The Totternhoe Stone has not yet been identified in the northern counties, but the Hunstanton section shows that its attenuated representative may still be found in Lincolnshire, since the Lower Chalk is certainly somewhat thicker than it is near Hunstanton.

DISCUSSION.

The PRESIDENT remarked on the difficulty of correlating a series of beds which have become greatly attenuated and meet together. He also commented on the difference of opinion as to the palæontological evidence where the fauna is elsewhere so largely developed. There was a difference as to geological position, though general agreement as to thinning.

Mr. E. T. NEWTON acknowledged how much the Society was indebted to the Authors. He was not acquainted with the district in question, but had at different times been consulted by both Mr. Hill and Mr. Clement Reid. Unfortunately circumstances had prevented those gentlemen from meeting to discuss this question, although they were desirous of doing so. With regard to the fossils collected

by Mr. Reid at West Dereham, the greater part were phosphatized, and might have been derived ; but the few which evidently belonged to the bed were thought to indicate Chalk-marl rather than Gault. Fragments of large *Inocerami* were such as occur in the Chalk. The correlation, by the Authors, of the Hunstanton Red Chalk with the Gault, if proved, was of great interest.

Dr. HINDE also spoke in verification of the Authors' work.

Mr. HUDLESTON regretted the length of time which had elapsed since he had entertained any of these questions, but the paper was calculated to arouse the old interest. He had always thought that the fossil contents of the Hunstanton red rock pointed most clearly to its being, in the main, on the horizon of the Upper Gault. These were, in the main, Mr. Wiltshire's original views, and the objections arising from lithological differences had been surmounted years ago. Consequently it was with the utmost surprise that he had read from time to time the several interpretations which had been put forth. In the present paper it would seem that the Authors claimed that the Hunstanton red rock represented the whole of the Gault. Certainly the occurrence of *Amm. interruptus* in the chalky Gault a very few miles south of Hunstanton was in favour of this view, but he should like to know of its occurrence at Hunstanton. The attenuation of the various beds so carefully traced out by the Authors, besides tending to throw much light on the basal Upper Cretaceous in Lincolnshire, would ultimately explain what had hitherto been regarded as an anomaly in the Chalk of Yorkshire.

Mr. TEALL had not studied the subject since he wrote his essay on the Potton and Wicken phosphatic deposits. He was pleased to find that there was good reason to believe that he had not made a mistake in recording the occurrence of Gault in West Dereham. The section was well exposed when he examined it, and he satisfied himself that the phosphatic nodules were, to some extent, at least, indigenous to the deposit in which they were found.

Mr. JUKES-BROWNE, in reply, alluded to the differences of opinion expressed by his colleagues on the Survey, and, as Mr. Newton had said, they had not yet met with a view to coming to an agreement, but he believed that it would be found that the work done in Norfolk would have much bearing upon the interpretation in Lincolnshire and Yorkshire. Mr. Reid had given up his reliance on the stratigraphy. The presence of *Amm. interruptus* in the base of the Marl at West Dereham was a fact that could not be got over. The presence of a nodule-bed did not necessitate any great break in the sequence ; it merely represented the residual washings of a certain amount of sediment. Their paper was a confirmation of Mr. Wiltshire's conclusions, and that author had himself heard of a red bed overlain by grey clay near Fritcham. The Hunstanton specimen of *Amm. interruptus* ought to be in the Woodwardian Museum. He would remark that *Amm. rostratus* was not confined to the Upper Gault, but was common in the Lower Gault of Buckinghamshire, where there was a mixture of Upper and Lower Gault forms of Ammonites.

40. *On GROOVES and QUARTZITE BOULDERS in the ROGER MINE at DUKINFIELD.* By JAMES RADCLIFFE, Esq., F.G.S. (Read March 23, 1887.)

THE Roger Mine, shown on Ordnance sheet no. 105, six-inch scale, of Ashton-under-Lyne and Dukinfield, is extensively worked at Denton, Dukinfield, Ashton-under-Lyne, and in the neighbourhood of Oldham.

At Dukinfield coal is being worked at a depth of five hundred and fifty yards, and averages about four feet in thickness. Quartzite boulders have from time to time been found in this mine, and have been noticed on various occasions in communications to the Manchester Geological Society, in vols. xiii. and xiv. of their Transactions.

The groovings and boulders are not found in any mine or strata in this neighbourhood, except in what is known as the Roger Mine, which lies near the top of the middle series of the Manchester coalfield. But occasionally quartzite pebbles have been found by Mr. G. Wild, of Bardsley, in the Arley and Pomfret Mines. The single groovings vary in depth from a few inches to eighteen inches, and in width from one foot to three feet. Occasionally several of these grooves run close together, and then widen out into one broad "scour," or groove, of fifteen or even eighteen feet wide, as if the base of a large moving body had come in contact with the upper surface of the coal-bed. These grooves have been traced at intervals over a distance of from five to six hundred yards in length, and from fifty to sixty yards in width.

The Roger-Mine seam of coal is composed of three divisions:—the "upper," a soft, bright, free-burning coal; the "middle," or "bony-band," a hard, dull, stony-looking coal; the "lower," or bottom bed, a dull-looking coal with two partings. The dip of the measures is west, and has an inclination of 18 degrees. The mean line of bearing of the grooves is S. 50° E.; line of fault-slips &c. is S. 26° W. The line of the grooves is not connected with, nor is it nearly parallel to, any fault or fault-slips. There are no faults or dislocations of the strata for a considerable distance from where these grooves are seen. No fossil trees or specimens of *Stigmaria ficoides* are found with the boulders, or in the immediate neighbourhood of the grooves. The cleavage of the coal is about S. 15° E.

All the fault-slips, joints, &c. come upwards through the floor beneath the coal, through the coal, and into the roof overlying the coal, which is not the case with the grooves; these are not seen in the floor, nor do they ever reach the bottom of the coal; they rarely extend to the middle coal, the "bony-band" being undisturbed except in two cases I noticed: one in the form of an undulating ridge in the "bony-band" on one side of the groove, as if caused by pressure from the centre of the groove, which, being in the upper

part of the seam only, the cause must have been from above, and not from below; the groove could not be made from below without affecting the strata below the coal, and the coal in which the groove is made. In the case of our faults &c., the cause is from below, for we often find them in a lower seam, and entirely absent from the upper ones.

In the cross-sections of the grooves are seen layers of the same kind of shale, varying in colour exactly the same as on each side where the coal-seam is intact; these layers increase in thickness at the lower part of the groove, and gradually lessen in thickness as they near the top of the groove, until they become parallel to the layers in the strata on each side of the groove, the sides of which are raised up a little, as if they had been pressed by the passage of a body along the groove. Where the sides are so pressed the "bord" or "cleat" of the coal is destroyed, and often a mixture of coal and earthy matter is present. The groovings always commence with a narrow "scour" or small groove, then increase in breadth and depth, and afterwards thin entirely out.

Fig. 1.—*Plan of the Roger Mine, Dukinfield.*
(Scale 100 yards to 1 inch.)

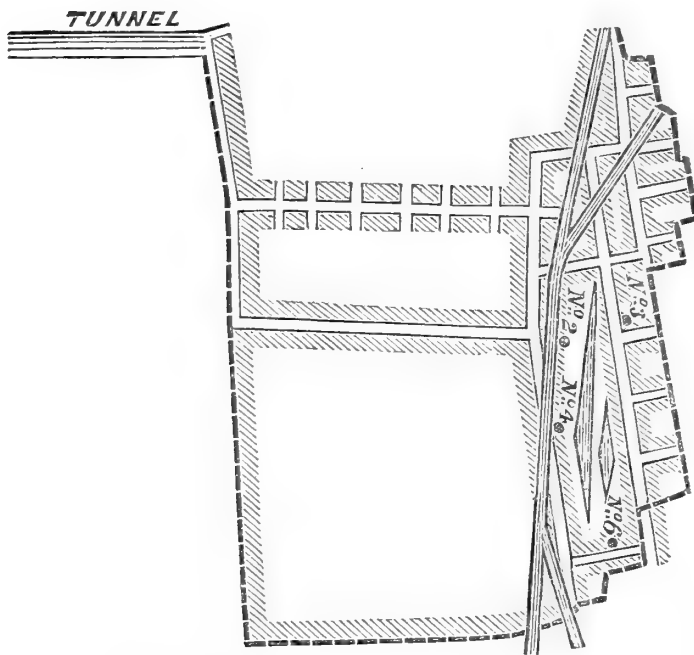

The tinted bands indicate grooves.

On the plan (fig. 1) is shown the position in which several of these boulders were found.

One of the boulders exhibited, with the block of coal upon which it lay, showed that the upper side of this block of coal is inferior in quality, a common occurrence immediately round about the boulders; the coal under the boulder shows a considerable amount of compression.

The roof in which these boulders are partly imbedded (part in roof and part in coal) consists of a grey shale, of an argillaceous character, with dark shades of carbonaceous shale forming layers varying in colour and from three to four feet in thickness up to a black parting, above which is a light-grey shale with rock binds; the floor upon which the Roger coal rests is an inferior fire-clay mixed with bands of coaly matter.

Figs. 2-5.—*Boulders in Coal, in the Roger Mine.*

Fig. 2.

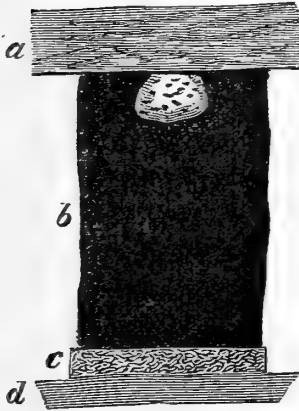

Fig. 3.



Fig. 4.

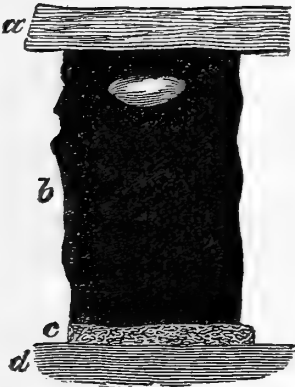
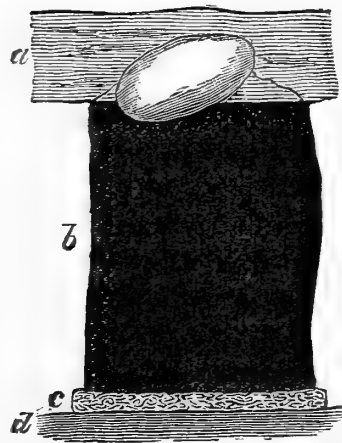

Fig. 5.



a. Metal with rock-bands.
b. Coal.

c. Soft holing dirt.
d. Inferior fire-clay.

The boulders are coal-blackened only as far as they are buried in the coal, and appear to have been dropped quietly on to a soft bottom; in one instance the boulder stood edgeway up, not flat down as the others were.

The sectional sketches (figs. 2-5) show the positions the boulders occupied in the measures in which they were found, they being foreign to the surrounding strata, much harder, different in form and structure.

No. 2 boulder (fig. 2) found imbedded in the coal, the upper edge

flattened, and level with the top of the coal-seam; it is rough, angular, and pitted with holes from three eighths to three quarters of an inch in depth, on its sides and end.

- No. 3 boulder (fig. 3) found on the top of the coal-seam, but only partly imbedded in the coal, the other part in the roof, the layers of which were parallel on each side of the boulder; the top and one side flattened, subangular, the carbonaceous coating mixed with iron pyrites.
- No. 4 boulder (fig. 4), very smooth and round, found entirely covered by the coal, the top of the boulder being six inches below the top of the coal; where this occurs the coal covering the boulder is of an inferior character and shaly, often mixed with thin partings of dirt and shale.
- No. 6 boulder (fig. 5) found resting on the coal-seam, a little imbedded, and partly surrounded by coal-shale, and covered with the roof, same in kind as the surrounding strata; surface smooth.

For the following details of the mineral composition of these boulders, I am indebted to the kindness of Professor Bonney, F.R.S.

No. 1 boulder weighs one hundred and sixty-six pounds, and is "a quartzite, grains mostly angular, some subangular, a few moderately rounded, maximum about $\cdot 027$ ", but the majority about half the size; occasional small grains of chalcedonic aspect, such as might come from a very minutely granular quartzite, a vein, or a fine-grained schist. There are besides some small opaque grains, probably iron-oxide, a few of a mineral resembling a rather dirty epidote, and two or three of tourmaline, with some flakes of white mica, and perhaps a little felspar."

No. 2 boulder weighs one hundred pounds. "A hard quartzose grit, composed of fragments much about the same size and shape as in the last; but in these there is a larger proportion of the chalcedonic quartz, which sometimes strongly suggests a derivation from a very fine-grained schist. There is also a considerable number of brown earthy-looking grains; these may be decomposed felspar, but many of them have much more the appearance of a decomposed devitrified rhyolite, though not of a very acid type; some may be compact argillites. The evidence as to the nature of these is hardly conclusive. The slide contains a very few flakes of mica, and a grain or two of epidote, hornblende (?), and tourmaline, but fewer than in the last case."

No. 3 boulder weighs four pounds. "A fine-grained grit formed of fragments commencing about $\cdot 005$ " in diameter; angular in shape, consisting of quartz, a felspathic substance (as to the exact nature of which it is difficult to pronounce), about equal in quantity to the quartz. There are flakes of mica, green-coloured and white, granules of iron-oxide, and, as before, one or two grains, probably epidote and tourmaline."

No. 4 boulder weighs twelve pounds. "A rock very similar to

No. 1, but perhaps with a shade more earthy matter among the granules of quartz. We find the same adventitious minerals."

No. 5 boulder weighs five pounds. "A grit somewhat resembling No. 2, or intermediate in character between it and No. 3. Fragments rather distinctly angular. I recognize some felspar by its plagioclastic twinning, but a good many of the grains suggest either an argillite or a decomposed rhyolitic rock. There are granules and specks of iron-oxide, two or three grains of tourmaline, and a few flakes of mica."

No. 6 boulder weighs thirty-one pounds. "A quartz-grit, rather ferrite-stained; grains rather variable in size and shape, the larger and rarer about .025" diameter. The quartz, besides minute cavities, contains occasional belonites, rutile (?); one or two grains are chalcidonic. There are also grains of iron-oxide, epidote and tourmaline (rare), and flakes of mica and, as before, a few fragments of decomposed felspar (?).

"In more than one of these specimens secondary quartz can be seen, deposited in crystalline continuity with the original fragments. Nos. 1 and 4, especially, bear a very close resemblance to the rock of a quartzite pebble found by Mr. Gresley in a coal-seam in Leicestershire, and to that of a large pebble taken out of the thirteenth coal at the Cannock-Chase Colliery near Rugeley.

"These quartzites present considerable resemblance to the rocks of some of the pebbles in the Bunter conglomerate of the midland counties, in which occasional grains of tourmaline, and of the mineral, which I have identified as probably epidote, may be found.

"They also resemble some of the quartzites in the Loch-Maree district, in which also these two minerals may be detected."

DISCUSSION.

Mr. W. W. SMYTH said the occurrence of the boulders was an interesting phenomenon, on account of the absence of pebbles generally throughout the Coal-measures above the Millstone Grit. Only now and then, throughout the enormous area of coal daily raised, some of these boulders were unearthed. The boulders are worn on the surface, polished and sometimes striated. He had seen, in company with the late Mr. Binney, a number of these boulders, some with a coating of coal, others partly coated with a film of iron pyrites, just like some slickenside surfaces. One popular explanation was that these boulders were meteorites, an utterly untenable supposition. He had never seen one of these boulders actually imbedded. The whole subject so far appeared to be very obscure.

Prof. BOYD DAWKINS said such boulders were far from uncommon in parts of Lancashire, and all appear to be of a very similar quartzite to the specimens exhibited. The grooves were not necessarily connected with the boulders. The upper surface of a coal-seam was generally uneven, and often showed denudation by water. He had seen remarkable markings made apparently by snags. He was

inclined to think that the boulders came from some of the Pre-Carboniferous conglomerates in the north of England and Scotland. These boulders may have been transported to their present position by roots of trees.

Mr. BLANFORD suggested that the grooves might have been caused by floods at the time when the beds were being deposited. He had seen similar excavations in plains over which water had passed. He also noticed how rapidly evidence of glacial action in Carboniferous times is accumulating in various parts of the world.

Prof. BONNEY pointed out that boulders were sometimes imbedded in the coal, and did not always project above the seam.

41. On *CHONDROSTEUS ACIPENSEROIDES*, *Agassiz*.

By JAMES W. DAVIS, Esq., F.L.S., &c. (Read March 9, 1887.)

[PLATE XXIII.]

Two species of *Chondrosteus* have been described by Sir Philip Egerton, viz. *Chondrosteus acipenseroides* and *C. crassior*. Both were obtained from the Lias of Lyme Regis. The former species was known to Louis Agassiz, who named, but did not describe it ('Poissons Fossiles,' vol. ii. part 2, p. 280). In 1858 Egerton communicated a paper to the Royal Society (Phil. Trans. vol. xlviii. p. 871) on *Chondrosteus*, in which he described a number of specimens, which he referred to the species named by Agassiz and to the second one named above. The specimen which afforded the most perfect description was in a slab of indurated shale. A part of the head and the tail were missing; the length of the parts preserved was 15 inches, and the total length of the fish was estimated at 24 inches. This, together with examples of the head of *C. acipenseroides*, and a head and a good example of the tail of *C. crassior*, afforded a large amount of detailed information, on which Sir Philip Egerton was enabled to base the description and the determination of the genus. The characters of the species are indicated as follows (*loc. cit.* p. 883):—"The numerous specimens derived from smaller individuals present indications of two species, one having the bones of the head thin and smooth, the other being characterized by stronger cranial plates, having a granulated exterior. The anal fins of the latter are more massive, and have the transverse articulations at shorter intervals. I propose to retain the Agassizian name *Chondrosteus acipenseroides* for the former, and to designate the latter as *Chondrosteus crassior*." In addition to these, mention is also made of a third species, *C. pachyurus*, a large fish, estimated at 5 feet in length; only fragments were known, the tail being most perfectly preserved. Of the tail, the most remarkable character is "the excessive development of the scales bordering the upper margin. The size and solidity of these scales is such that they more resemble the broad teeth of an *Acrodus* than any dermal development with which I am acquainted." The length of the tail is about 18 inches.

Examples of the fossil fishes of the genus *Chondrosteus*, Agass., are not unfrequently found in the Lias shales of Lyme Regis; but it rarely happens that a specimen is found so well preserved as the one it is now proposed to describe (Pl. XXIII.). The head (with the exception of the snout), the trunk, and the tail are exceptionally complete, and during fossilization have maintained their proper relative position. The bones remaining in their natural position afford evidence, which has not hitherto been available, of the exact size and relative proportions of the fish; and, what is of equal or still greater importance, in addition to the osseous structure of the head and that of the tail, a considerable portion of the elements of the vertebral column is preserved. The dorsal and pectoral fins are

present, and the ventrals are represented by a mass of bony ray broken and fragmentary, but indicating clearly the position of the fins. The anal fin is wanting in this specimen. The length of the fish, from the tip of the upper lobe of the tail to the anterior extremity of the head, so far as preserved, is 44 inches. Of this length, the tail occupies 12 inches; and the head, from the posterior margin of the scapular arch to the anterior extremity of the mandible, is 9·2 inches. The height of the posterior part of the head is 9 inches. The body behind the head decreases rapidly in size; between the dorsal surface and the pectoral fin there is 7·5 inches. At the anterior base of the dorsal fin, ten inches further back, the depth has decreased to 5·5 inches, and this is reduced at the tail to 2·5 inches. The expansion of the caudal fin is very rapid, the extremities of the lobes being 13 inches apart. The single dorsal fin is separated from the occiput by a distance of 11·5 inches; its base extends 6·5 inches, and its posterior extremity is 5·5 inches from the base of the caudal fin. The ventral fin is opposite to the posterior part of the dorsal; its anterior rays are separated from the anterior rays of the pectoral fin by a distance of 13 inches, and from the base of the tail by about 7 inches. Its base was between 4 and 5 inches in extent.

The head in this specimen is proportionately larger and deeper than the body of the fish. This comparative largeness is due, to some extent, to the effects of lateral pressure during fossilization, by which the skull has been squeezed flat on its side. The cranial bones, which covered the surface of the crown, are pressed into a lateral position, dividing down each side from the median suture. The facial and maxillary, the hyoid and branchial elements are also pushed considerably from their proper position, though they still maintain their relative positions with regard to each other.

The head, as preserved in this specimen, has an almost circular outline, with a diameter of about 9·0 inches (see diagram, p. 607). The anterior termination of the snout is absent, and no evidence is afforded as to the length to which it may have extended forward, this part of the specimen having been most unfortunately broken and lost during its extraction from the matrix.

The cranium was protected by dermal bones or scutes. The upper surface was enveloped by large plates, which extended downwards so as to encircle the orbit, and the postero-lateral surfaces were covered by a large expansion of the opercular apparatus. The anterior portion of the head beneath the orbit does not exhibit any traces of external defence. In this respect the fossil *Chondrosteus* differs materially from the existing Sturgeons, in which the whole of the superior surface of the head is enveloped in osseous plates. The opercular apparatus is large and well developed; its posterior margin rests on the depressed anterior surface of the scapular arch. The operculum (28*) is 3·5 inches in height and 3·0 inches in breadth; its anterior margin is somewhat angular, and the inferior one forms a concavity fitting to the upper convex margin of the

* The numbers thus given in brackets are those employed by Sir Richard Owen to indicate the bones of the head.

suboperculum (32). The latter is 2·0 inches in breadth and 1·0 inch in depth, ovoid in outline, with an acute angle behind and an obtuse

Diagram of the Bones of the Head of Chondrosteus acipenseroides
(One third natural size.)

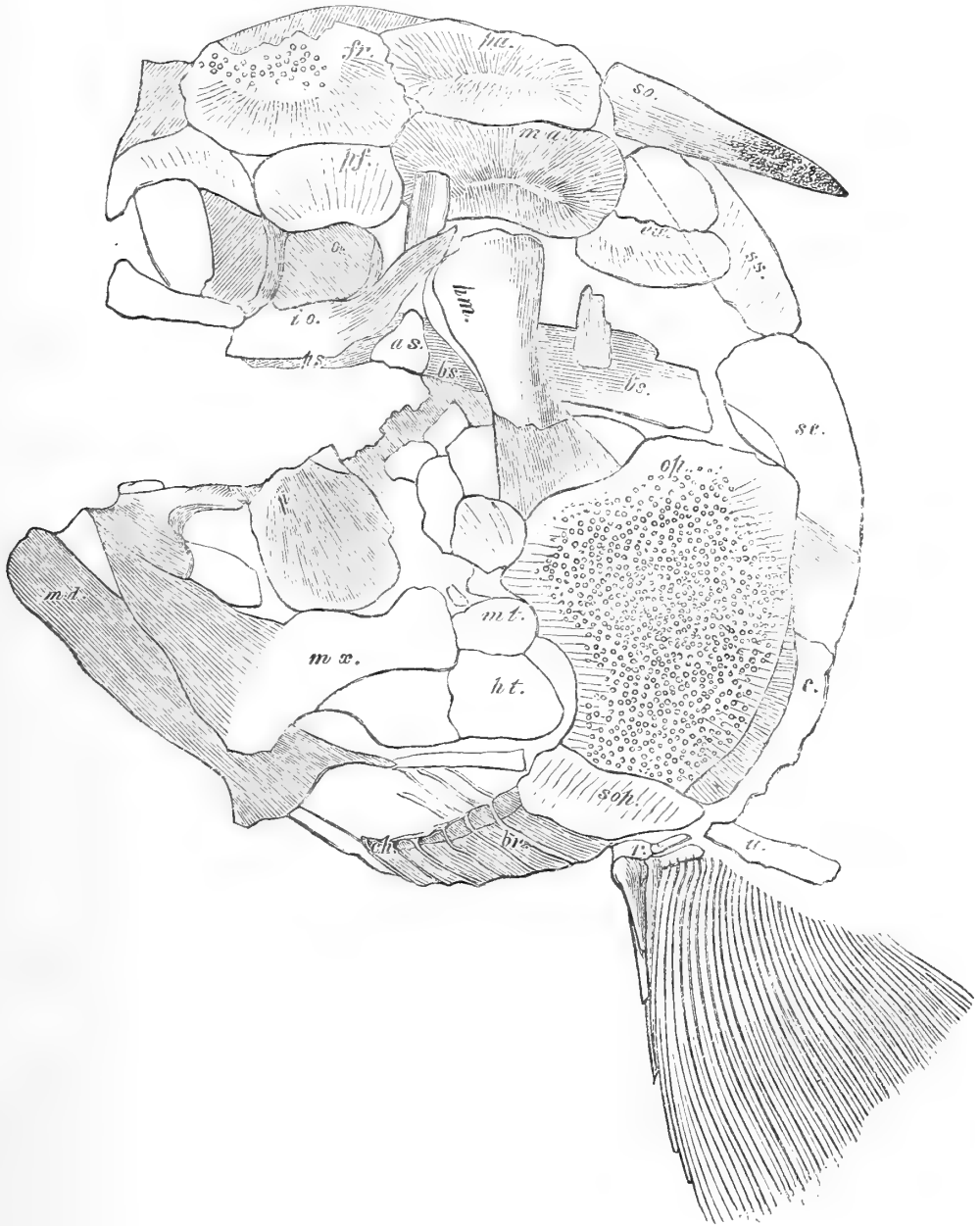

pf, postfrontal.

fr, frontal.

pa, parietal.

ma, mastoid.

so, supraoccipital.

ex, exoccipital or petrosal.

ss, suprascapular.

hm, hyomandibular.

bs, basisphenoid.

sc, scapular.

op, operculum.

e, coracoid.

sop, suboperculum.

r, radius.

v, ulna.

br, branchiostegal
rays.

ch, ceratohyal.

ht, hypotympanic.

mt, mesotympanic.

mx, maxilla.

md, mandible.

p, palatine.

as, alisphenoid.

ps, presphenoid.

io, infraorbital.

o, orbit.

one in front. The external surfaces of the opercular bones are rudely punctate, and exhibit a series of lines or striæ radiating from the upper anterior surface towards the margin. To the lower concave

anterior margin of the operculum there was, probably, attached an inter-operculum ; but though its place appears to be indicated, there is no trace of the bone remaining.

The frontals, postfrontals, parietals, mastoid, and some of the occipital bones are present. There is indication of an extension of the frontals on a portion of the matrix, which extends about an inch forward from that part of the dermal bones actually preserved. All the bones are united by sutures. The frontals are 2·5 inches in length and 1·0 inch in breadth ; they are broadest posteriorly, where they join the parietals and mastoid. Attached to the inferior margin of the frontal is the postfrontal (sphenotic of Parker), shorter than the frontal, and extending downwards so as to embrace the upper margin of the orbit ; its posterior margin articulates with the mastoid. The mastoid is a large plate, with a length of 3·0 inches ; it is 1·3 inch in width near the posterior extremity, diminishing forward to 1·0 inch. The centre of the plate is considerably raised and forms a ridge ; from this the surface declines to the extremities, which are much thinner and are jagged and uneven where attached to the neighbouring plates. The external surface of the mastoid is coarsely striated or ridged. The ridges radiate, for the most part, from the centre towards the margin ; the surface of the ridges is covered by strips of ganoine, apparently thin, and not extending to the base of the intermediate striations. The parietal plates are equal in size to the frontals ; they are rhomboidal in outline, roughly striated on the surface, the striæ radiating from a slight elevation of the median portion. Connected with the posterior margin of the parietal plate there is a long and narrow bone. It extends backwards 3·0 inches, and is 0·5 inch in width. It presents the appearance of being a lateral bone, having a complementary one on the opposite side of the head, to which it is ankylosed or joined by suture. In the recent Sturgeon a single median bone terminates the cranial covering, and is succeeded by the closely-imbricating series of scutes, which extend along the dorsal surface of the body. In the fossil there is no evidence of such a series of dermal scutes, and this posterior portion of the dermal covering of the cranium is proportionately much elongated ; the lateral surfaces of the combined plates are produced along the median line, and form a raised and acutely angular ridge. The posterior surface of the plate is covered with coarse pustulations of enamel ; its anterior portion envelopes, and apparently affords attachment to, the upper extremity of the suprascapular. The bones occupy the position, and are probably the equivalents, of the supraoccipital (8). Another bone, thin and widely expanded, whose posterior margin is overlain by the suprascapular, whilst its anterior one lies hidden by the dermal bones of the postorbital region of the skull, from its position must represent either the exoccipital or the petrosal portion of the base of the cranium, and may have been connected with the basisphenoid by cartilage when living, though now separated by a distance of 0·25 inch.

The orbit is oval, 1·2 inch from back to front, and 0·75 inch in height. Its upper margin is bounded by the postfrontal (sphenotic) bone, to the lower anterior extremity of which there is attached a long and narrow bone (100), which bounds the orbit anteriorly and separates it from the nasal orifice. The anteorbital region of the head is, for the most part, lost. Sufficient indication of the arrangement of the bones composing that part is left to show that the nostril was large, and was, in its turn, surrounded by osseous structures forming the anterior termination of the snout; unfortunately the extent to which the latter projected cannot be ascertained, but a comparison of the bones composing the skull of the fossil with those of recent species appears to indicate a short rather than a long snout. The infraorbital margin is occupied by a bone, or series of bones, it is not easy to determine which, extending backwards from the lower part of the one already mentioned as dividing the orbit from the nasal cavity beneath the orbit, forming a semicircular ring, and joining the under surface of the cranium at the point where the postfrontal is attached to the squamosal or mastoid.

The base of the skull is formed by bones more completely ossified than in the existing species of Sturgeons, and forming the roof of the branchial, as well as the buccal cavity. The posterior portion of the basisphenoid (6) extends posteriorly considerably beyond the point of attachment of the suprascapula (post-temporal). It is broadly expanded, thin, and fibrous in structure. Its extension forwards is hidden for some distance by the epitympanic (hyomandibular), beyond which it can be again traced, extending beneath the orbit and the nasal cavity. Lateral expansions of the bone appear beneath the suture joining the mastoid with the frontal, and, in all probability, represent the alisphenoid (prooticum); while the extension further forward may represent the presphenoid or vomerine portion of the roof of the mouth.

The posterior margin of the head is formed by the scapular arch, which extends in the form of a semicircle from the occipital region of the skull, giving attachment to the pectoral fin, and extending as far forward as the anterior margin of the operculum. The upper portion of the arch is formed by the suprascapular (post-temporal, 46), extending from the base of the skull 2·5 inches; it is long and narrow, thick posteriorly, and convex in outline; anteriorly, the bone is thinner and slightly expanded towards its lower extremity. Attached to the suprascapula is the second bone of the series, the scapular (supraclavicular, 47); it is 3·0 inches in length, thick and strong, slightly over 1·0 inch in breadth in the upper part, but becoming narrower towards its lower extremity. The anterior portion of this element of the arch, like that of the suprascapular, is comparatively thin and aliform. The coracoid (clavicular, 48) is a large bone, extending beneath the scapula at its upper extremity, and curving downwards anteriorly beneath the opercular apparatus, by which it is, to a large extent, enveloped. It is thick and rounded, affording a strong support to the large pectoral fin. Its exact form is hidden by the overlapping operculum,

and the inner extent of the bone cannot be distinguished. Between the coracoid and the pectoral fin there are two bones connecting them together. The anterior one, 0·7 inch in breadth and 0·25 in length, is rounded in front, where it affords a substantial support to the large anterior ray of the pectoral fin; behind it is somewhat attenuated. The second intermediate bone extends from the posterior extremity of the one described to the termination of the base of the fin, and is nearly 2·0 inches in extent; to it are attached the bases of the remaining rays of the pectoral fin. The two bones probably represent the radius and ulna of Owen (coracoid and scapula of Parker and Huxley). Sir Philip Egerton*, in his description of the genus *Chondrosteus*, states that the elements of the bony girdle encircling the thoracic region, which in recent Sturgeons are three in number, in the fossil genus are reduced to two, by the coalescence of the scapula and the coracoid. "The external portion [of the combined scapulo-coracoid] is crescentic, the concavity being anterior for the reception of the opercular flap. At the point of attachment of the pectoral fin the bone is thick and rounded; the upper or scapular portion expands gradually into a triangular plate, thinning off towards the upper extremity for adjustment with the suprascapular bone; the lower or coracoid portion also expands as it descends, sweeping under the thorax, and meeting the corresponding bone of the opposite side on the median line. . . . Anteriorly, each scapulo-coracoid expands into a broad concave plate, directed inwards and forming the platform of the branchial cavity, and partitioning it off from the thoracic cavity." In the specimen now described the great lateral and anterior expansions do not appear to be developed as in the specimens described by Sir P. Egerton; and the scapula and coracoid are separated, the two overlapping midway between the attachment of the pectoral fin and the junction with the suprascapular. The small bones connecting the scapular arch with the pectoral fin in the species already referred to are said to be a series of strong metacarpal bones, of which those supporting the hinder rays are longest. A reference to the plate (*op. cit.* lxxix. 57) on which these bones are represented will show that the metacarpals are not similar to the bones existing in this specimen, described as equivalent to the ulna and radius; they have the appearance of being merely fragments of the rays of the pectoral fin which have become detached. This pectoral fin is large and comprises 42 rays. The anterior ray is spinous, thick, with expanded base for attachment; it gradually tapers to a point, terminating 2·5 inches from the base. The succeeding rays are the longest. In this specimen there is preserved a length of 4·25 inches, but the distal extremities are imperfect, and at least one inch more would be required to complete the length of the fin-rays. The base of the fin nearly approaches 3·0 inches in length, and the fin-rays gradually diminish backward; the posterior rays are not more than half the length of the anterior ones. The rays increase, towards the distal end, by

* "On *Chondrosteus*, an extinct Genus of the Sturionidæ found in the Lias formation at Lyme-Regis," *Phil. Trans.* vol. cxlviii. 1858, p. 871.

bifurcation. A keel extends along the lateral surface of each ray, and a line of pustulations extends along the median surface of the keel. The anterior ray or spine is quite smooth. The fin is capable of wide expansion; as preserved, the breadth of the outer margin of the fin is equal to the length of the anterior rays. The pectoral fins in this species approach the existing forms in possessing a strong, spinous anterior ray, and, to the same extent, seem to differ from the fossil forms described by Sir Philip Egerton from the same locality.

The tympanic arch or suspensorium consists of three parts, each of which is represented by a tolerably complete ossification, and together they connect the cranial bones with the mandible. The epitympanic or hyomandibular (23) is the most prominent bone of the series: it is 3·3 inches in length, the articular surface is 1·2 inch across; it is contracted in the middle, and expands again at its lower extremity to slightly under one inch in breadth. The bone is thick and strong, and has a solid fibrous appearance. Its upper extremity has a double surface for articulation, and was connected with the mastoid, and probably with the postfrontal bone, though the connexion is not quite so clear as that with the mastoid in this specimen. The lower extremity is rounded and thinner than the upper; to it is attached a smaller plate, the mesotympanic or symplectic (31); the latter is partially covered by the operculum posteriorly. Its exposed surface is 0·8 inch across; its lower extremity affords attachment to the hypotympanic or quadrate (26), an ossification of considerable size supporting the posterior extremity of the mandible. Its form is not readily distinguishable. Its posterior margin is covered by the operculum; anteriorly its extent is lost amidst several smaller bones which may pertain to the hyoid apparatus.

The hyoid apparatus is mostly hidden by the bones of the tympanum and the operculum. Between the suboperculum and the mandible, a distance of 2 or 3 inches, the ceratohyal (38) may be distinguished, with six short bones attached to it, the latter evidently bearing some relation to the branchiostegal rays (43); the posterior ray is one inch in length, those succeeding are shorter, and they also diminish in thickness. The anterior bones of the hyoid arch are obscure. In a cavity above the ceratohyal, bounded by the posterior part of the lower jaw and the hypotympanic, three bones are exhibited; the exposed parts are 0·2 inch in thickness at the anterior end, decreasing backwards as they sink beneath the superincumbent bones. These osseous rods represent some part of the branchial apparatus, probably the basal portion of the ceratobranchials.

The mandibles and the maxillaries in this species are large and well ossified; in this respect differing considerably from the existing species. There is no evidence of teeth, and the inference naturally arises that the fossil, like its recent representatives, was devoid of teeth. The mandible (34) is 4·5 inches in length, to the extent preserved; but it is probable that a little more must be added, because the bone ends abruptly; its anterior termination is wanting. The external

surface of the jaw is strong and rounded, 0·5 inch in diameter. Posteriorly it becomes thinner and assumes an expanded form; the inferior margin is also rounded, whilst the superior extremity is produced to form a styliform process extending backward quite half an inch. It was probably by this process that the mandibular bone was connected with the quadrate or hypotympanic, with which it is in close proximity. The part preserved may be equivalent to the dentary element in the lower jaw of the Teleosteans; and the posterior articular portion which connected the jaw with the hypotympanic, in this specimen defective, may have been mostly cartilaginous, with a thin osseous structure, of which there is a trace extending over the ceratobranchials. The maxillary bone (18) is large and crescentic in outline; its anterior portion, like that of the mandible, is thicker and stronger than the posterior. It commences in front in connexion with the premaxillary; the upper margin of the former is overlain by the lower portion of the latter. The total length of the maxilla, allowing for its curvature, is 4·5 inches; its height at the anterior part is 0·5 inch. The upper surface is deeply concave, the lower one angular; the depth at 2·0 inches from the anterior extremity is increased to 1·0 inch; thence it decreases towards the upper posterior extremity to 0·35 inch about half an inch from the end. The latter again expands and is more or less rounded.

The posterior expansion of a large bone midway between the orbit and the maxilla is the palatine (22). It is 1·3 inch in breadth, the length of the part preserved is 2·0 inches. It has a fibrous structure radiating from the anterior extremity of the broken bone. Its posterior margin is rounded, the anterior part is constricted to 1·0 inch in breadth. The remaining part of the bone has disappeared with the whole of the anterior extremity of the head, by the loss of a portion of the slab on which the fossil is exposed. The posterior margin of the palatine is in close contact with the tympanic elements and with the posterior extremity of the upper jaw. Between the palatine and the epitympanic bone there are a few small bones or fragments, of an indefinite character, which cannot be localized with any amount of certainty.

Osseous neurapophyses are preserved in the anterior portion of the body. There is no trace of the vertebral column nor of ribs or hæmapophyses, except in the caudal fin, where hæmapophyses support the lower lobe, as will be mentioned hereafter. The neurapophyses extend from the occipital region of the skull, situated high in the body, to the base of the dorsal fin, a length of 13·0 inches. In this length there are preserved 35 neurapophyses representing the same number of vertebræ. The first ray of the dorsal fin is inserted above the 30th vertebra. The total number of vertebræ comprised in the spinal column would in all probability be from 80 to 85. The anterior neurapophyses are 0·7 inch in length, divided at the base for the passage of the spinal cord, somewhat constricted mesially, and expanded at the upper extremity to afford attachment to a second series of interspinous bones, 1·25 inch in

length, extending diagonally towards the dorsal surface of the body. The interspinous bones are more slender than the neurapophyses; they are forked at the base, and may afford protection to a second canal. Sir Philip Egerton* cites the description by Prof. Owen of the vertebræ in the existing Sturgeon as composed of "two superimposed pieces on each side, the basal portion bounding the neural canal, the apical portion the parallel canal, filled by fibrous elastic ligament and adipose tissue; above this is the single cartilaginous neural spine"†. Of the fossil examples described by Sir Philip Egerton, it is stated that the neurapophyses appear to be composed of two elements, corresponding to the basal and apical cartilages of the Sturgeon; but whether they embraced a second canal, running parallel with the spinal cord, could not be ascertained. The divided base of the apical neurapophyses or spines of the specimen now described affords conclusive evidence that a second canal did exist in the fossil *Chondrosteus*, as in the recent Sturgeon. In addition to the two sets of basal and apical neurapophyses, the dorsal fin is supported by an additional double series of bones. Connected with the apical neurapophyses there is a series of interneural spines, more or less pointed at their lower extremity, exceeding an inch in length, and with their upper extremities expanded so as to afford attachment to a second range of interneurals, to which the rays of the dorsal fin are attached. Between the expanded and rounded extremities of the two rows of interneural spines there is a continuous space which indicates a cartilaginous attachment of no small size and strength; its decay has left the two sets of bones separated by 0·3 of an inch. The interspinous bones are strong, and would afford a firm base of attachment for the rays of the large dorsal fin.

The dorsal fin extends along the back 6·5 inches, and its longest rays are fully 6·0 inches in length. It is composed of 66 rays, of which the anterior 15 are short and more or less rudimentary; they occupy 1·75 inch of the base of the fin. The first rays are short, thick, and imbricating; they gradually increase in length to about an inch. All are simple. The succeeding rays are transversely jointed, and increase rapidly in length to the seventh; the twenty-second from the anterior extremity of the fin is the longest, the succeeding rays gradually diminish to the posterior extremity of the fin. All the rays, except the anterior fifteen, are jointed quite from the base. The longest anterior rays bifurcate three inches from the base, and the division is repeated nearer the distal extremity. The bifurcation commences in the posterior rays nearer the base in proportion to the length.

The ventral fin is much disturbed. The fin-rays are numerous, many of the fragments are thick and strong, and indicate somewhat large and powerful fins. There is no appearance of ordinary pubic bones; but the anterior origin of the fin is marked by a V-shaped bone 1·2 in length; it apparently forms a single piece for 0·5 inch,

* *Op. cit.* p. 879.

† Hunterian Lectures, 8vo, vol. ii. p. 53 (1846)

beyond which it bifurcates, possibly to support the two ventral fins. The bone is opposite to the anterior insertion of the dorsal fin.

The anal fin is not represented.

The caudal fin is very large, and a most powerful organ of propulsion. The upper lobe, as in the recent Sturgeon, is the longer of the two, and its extremity is more pointed than that of the lower one. The length of the upper lobe is 12·0 inches, that of the lower 10·5 inches, and the terminations of the two are 13·0 inches apart. Along the median portion of the upper lobe there is a series of dermal scales or scutes; at the basal part of the tail they cover about an inch in breadth and extend almost to the termination of the tail, gradually diminishing in area until they end in a point. The scales at the base of the tail are of an elongated oval form; posteriorly they are greatly elongated and assume a rod-like form pointed at each end. The upper external margin of the fin is formed of a series of large, sigmoidally-curved, imbricating, fulcral scales. Those attached immediately behind the pedicle of the tail are about 1·0 inch in length, 0·2 inch in thickness in the middle; the basal and distal extremities are somewhat spatulate and thin. Succeeding scales become more attenuated, and midway their length has increased to 2·5 inches, with a medium thickness of 0·1 inch; thence to the end they diminish both in length and thickness. The strong basal fulcral scales are directly supported by a series of short but thick neuropophyses. The latter do not appear to extend more than two inches beyond the base of the tail. The lower lobe of the tail is supported by hæmapophyses of larger size and more solid construction than the neuropophyses; they are expanded at the base, and have evidently been firmly attached to a powerful vertebral axis. The latter was entirely cartilaginous and has disappeared. The hæmapophyses can be distinguished a distance of six inches from the base of the tail; they gradually diminish in length, but become broader and spatulate as they approach the termination of the vertebral column. Attached to the hæmapophyses there is a long series of interhæmal bones, which form the base of attachment for the rays of the fin. The latter are strong and jointed from the base. A few short rudimentary rays are followed by others which extend to the extremity of the lobe; they are divided towards the extremity of each ray, the divided portions again bifurcating until the external margin of the fin has assumed a more or less filamentous condition. The rays decrease in length and thickness as they are successively attached to the fin, extending quite to the extremity of the upper lobe. From the base to a point halfway towards the termination of the upper lobe 72 rays may be counted; beyond this point there are many others, but the actual number is not easy to determine.

The specimen of *Chondrosteus* described in the preceding pages is nearly twice the length of those described by Sir Philip Egerton (excluding *C. pachyurus*, which is only mentioned incidentally), whilst the depth of the body, taken in front of the dorsal fin, is 6 inches, the same as that of *C. acipenseroides*, so that this species approaches

much more nearly to the existing types. In this specimen the length of the body from the base of the pectoral fin to the pedicle of the caudal fin is 24 inches, the length of the caudal is 12 inches; in Egerton's specimens the proportions are as 15 inches to 9 inches; though it is possible that as the caudal fin was not attached to the body in the latter instance, the estimation of the proportionate lengths of the body and tail may have been exaggerated in the case of the latter. The ventral and dorsal fins are described as being midway between the base of the pectoral and that of the caudal; in this specimen the distance between the pectoral and ventral is 14 inches, and between the latter and the caudal 10 inches. The dorsal fin of this specimen is readily distinguished by the large number of short rudimentary or accessory rays forming its anterior portion; and the pectoral fin is possessed of a strong anterior spinous ray very similar to that of some recent Sturgeons.

Some differences in the cranial anatomy have been already mentioned. The division of the scapular arch into three parts—the suprascapula, the scapula, and the coracoid—in this specimen appears to be undoubted, whilst in those previously described the scapula and coracoid are said to be united. In the existing Sturgeons the two latter ossifications of the shoulder-girdle are separate*, and in the Ganoid fishes generally this is also the case.

The mandibular suspensorium, in the examples described by Sir P. Egerton, is stated to consist of a large epitympanic bone connected with the tympanic pedicle; the succeeding cartilages, the mesotympanic and hypotympanic, which are represented in the recent Sturgeon by two cartilages, are united to form one bony plate. This united bone is very small and feeble as compared with the epitympanic, and is considered ill-adapted, either in form or dimensions, to afford an articulation strong enough to support the mandibular and maxillary organs. Dr. Günther† states that the suspensorium in the Sturgeon is movably attached to the side of the skull, and consists of two pieces, a hyomandibular (epitympanic) and a symplectic, which now appears for the first time as a separate piece, and to which the hyoid is attached; as regards the second part of the suspensorial apparatus the Sturgeons are distinctly in advance of the palæoniscoid Ganoids, in which Dr. Traquair has seen no trace of symplectic‡.

A careful comparison of the numerous specimens of the genus *Chondrosteus*, at present located in the New Natural History department of the British Museum, has led to the conclusion that there is no specific difference between the species *Chondrosteus acipenseroides*, Agassiz, and *C. crassior*, Egerton. The characters separating the two, as stated by Sir Philip Egerton, are slight, consisting in the relative thickness of the cranial bones and the position of the anal fin. The former difference can scarcely be maintained, because the specimens merge gradually the one into the other, and

* Prof. W. K. Parker, "On the Shoulder-girdle and Sternum."

† 'Study of Fishes,' 1880, p. 76.

‡ Palæoniscidæ (Palæontographical Soc., vol. xxxi. 1877, p. 17)

the thicker ossification appears to depend more on the age of the fish than anything else. The evidence of the anal fin is derived from very fragmentary specimens. The anal fin of *C. crassior* is described as more massive and having the transverse articulations at shorter intervals than the anal fin of *C. acipenseroides*—the latter being represented in the specimen depicted on plate lxvii. (Phil. Trans.), and the former, in conjunction with the caudal fin regarded by the author as belonging to the species *C. crassior*, on pl. lxx. It was unfortunate that no specimen was known to Sir Philip Egerton having the body sufficiently well preserved to show the actual relationship of the caudal fin with the remaining constituents. The specimen herein described proves that there is no difference between the tail described as belonging to *C. crassior* and the one actually attached in this specimen to the body of *C. acipenseroides*, so that the former must be united with the latter species. It is very probable that better preserved specimens will exhibit an equal similarity in the anal fins; and until such are found it must be remembered that the anal fin on which Sir Philip Egerton based his determination is the one attached to the caudal fin mentioned above, and which is undoubtedly the tail of *C. acipenseroides*, Ag.

EXPLANATION OF PLATE XXIII.

Specimen of *Chondrosteus acipenseroides*, Ag., from the Lias of Lyme Regis, one-sixth natural size. *op*, operculum; *p*, pubis (?); *v*, ventral fin.

DISCUSSION.

The PRESIDENT observed that the subject was one to which the Author had devoted much labour, and that the comparison of such fossil forms with existing ones was of the greatest importance.

Mr. SMITH WOODWARD regretted that there was no specimen to verify the drawings, which seemed to show the bones with unusual clearness. A figure of so instructive a fossil would be especially valuable; but he advocated a more modern nomenclature than that of the Author. He considered the absence of an anal fin accidental. These *Chondrostei* of the Lias formed the connecting-link between the old Palæoniscidæ and the living Sturgeons, notably *Polyodon*, and any contribution to their anatomy was thus very welcome to ichthyologists.

Mr. NEWTON remarked on the fact that the tail alone was all that Agassiz had to work upon. In 1858 Egerton gave further descriptions, including parts of the head, but his specimens were crushed. Mr. Davis's specimen was more perfect, and for the most part the bones of the head appeared to be in the position they ought to occupy. He criticized the position of the coracoid with reference to the scapula, the line between them being, as he thought, due to a break in the stone. The appearance of the mouth might also be due to breakage. He referred to the absence of the anal fin and to the apparently disjointed condition of the vertebral column.

The SECRETARY observed that the Author expressly noted the absence of the anal fin.



W H Crossland del et lith.

CHONDROSTEUS ACIPENSEROIDES, Agassiz.
One sixth natural size.

Minuten Boon. 1847

42. NOTES upon some CARBONIFEROUS SPECIES of MURCHISONIA in our PUBLIC MUSEUMS. By Miss JANE DONALD, Carlisle. (Read May 25th, 1887.)

[Communicated by J. G. GOODCHILD, Esq., F.G.S., of H.M. Geological Survey.]

[PLATE XXIV.]

It is exceedingly difficult to fix the limits of the genera of many fossil Gasteropoda and to ascertain their affinities with those of existing forms. As the soft parts of the animals are never preserved, the only data upon which we can rely are such as may be derived from the form and structure of the shell. The most characteristic feature in the *Murchisoniæ* is the slit in the outer lip, the successive filling-up of which gives rise to the formation of a band upon the whorls of the shell. Now this slit in the outer lip exists in several other genera, such as *Pleurotomaria*, *Pleurotoma*, some species of *Turritella*, *Siliquaria*, *Scissurella*, *Emarginula*, *Bellerophon*, and, to a greater or less degree, also in *Haliotis*, *Ianthina*, *Euomphalus*, &c. Of these genera, those which *Murchisonia* most resembles are *Pleurotomaria* and *Turritella*, and in some instances it is very difficult to draw the line between the genus *Murchisonia* and the genus *Pleurotomaria*; in both genera the slit is represented on the whorls by a well-defined band, and the only external difference between the shells is the form of the spire, that of *Murchisonia* being elongated, while in *Pleurotomaria* it is short. But there are shells of every intermediate length, and these have been referred sometimes to the one genus, and sometimes to the other. G. Lindström ('Silurian Gasteropoda and Pteropoda of Gotland,' p. 92*) thinks it well to limit the genus *Murchisonia* to shells which have a long slender spire of more than six whorls.

The structure of the shell of *Pleurotomaria* seems to differ from that of *Murchisonia* in the interior being nacreous, and G. Lindström states that many of the Gotlandic *Pleurotomariæ* have this inner pearly layer preserved, but he has not observed this structure in any of the *Murchisoniæ* from the same beds. In his description of *M. compressa* (p. 130) he says that "the nuclei have a glossy surface, and look as if the interior walls of the shell had been porcellanous." None of the British specimens of *Murchisonia* that I have examined have shown any evidence of the internal character of the shell. Indeed, from the manner in which most of these are preserved, it is difficult even to ascertain the relative thickness of the shell; in most instances it is thin, but in others it appears decidedly thick, compared with the size of the shell. This thickness may not have existed in the original shell, for Mr. Etheridge informs me that a thickening sometimes takes place when the test is replaced by some mineral substance, as is frequently the case in the Palæozoic Gasteropoda.

Struck by the external resemblance of the *Murchisoniæ* to the

* Kongl. Svenska Vet.-Akad. Handl. Bd. xix. (1881), no. vi.

Turritellæ, some of the earlier palæontologists referred them to that genus. But in 1841*, A. d'Archiac and E. de Verneuil classed them together in a new genus called *Murchisonia*, the possession of the sinus in the outer lip being considered to distinguish them from the genus *Turritella* and from other genera of elongated shells to which they had been referred. In 1859, J. W. Salter (Geol. Surv. Canada, dec. i. p. 18) separated from the typical *Murchisoniæ* elongated shells composed of rounded, bead-like whorls, and whose mouth is round, instead of being ovate and slightly channelled. To this group he gave the name of *Hormotoma*, and took *M. gracilis*, Hall, as the type.

Whitfield (Bull. Amer. Mus. Nat. Hist. vol. i. no. 8, 1886, p. 311) considers it advisable to form a distinct genus for some other shells which have hitherto been classed as *Murchisonia*. He calls this new genus *Lophospira*, and defines it thus:—"Shells univalve, with elongated spires, and strongly carinated or keeled volutions; whorls closely coiled in the upper part, but often becoming disconnected below from a too rapid descent of the coil. Central keel marking the position of a sinus or notch in the outer lip of the aperture. Axis usually minutely perforate when the whorls are not disconnected. Types *M. bicincta*=*M. Milleri*, Hall, and *M. helicteres*, Salter."

The exact value of these subdivisions can hardly be determined at present, but possibly the discovery of better-preserved specimens, and the detailed examination of the whole series of the Palæozoic forms possessing a slit in the outer lip, may eventually lead to the establishment of several well-defined subgenera.

It is a question, however, whether the *Murchisoniæ* may not be more nearly allied to some species of *Turritella* than was thought at one time; for recent investigations have brought to our knowledge the fact of some species of *Turritella* possessing a sinus in the outer lip. In January 1881, Mr. Marrat, of Liverpool, first pointed this out to me, and showed me some shells in the Liverpool Museum with a deep, narrow slit in the outer lip, similar to that of *Murchisonia*. These shells were collected in Bass's Straits, by Capt. W. H. Cawne-Warren (ship 'Bedfordshire'), Associate of the Lit. and Phil. Soc. of Liverpool, who presented them to the Museum; and Mr. Moore, the Curator, kindly enabled me to obtain two specimens in exchange for some fossil Gasteropoda. Mr. Marrat named this species *T. fissurata* (in lit.). In the Journ. Linn. Soc. Zoology, vol. xv. pp. 217-230, 1881, the Rev. Boog Watson described some species of *Turritella* with a sinus in the outer lip, obtained in the dredgings of H.M.S. 'Challenger.' These have since been more fully described and figured by him in 'The Voyage of H.M.S. Challenger, Report on the Gasteropoda, Zoology,' vol. xv. 1886, p. 466. The depth of the sinus in *Turritella* seems to vary from a mere curve to a deep, V-shaped slit, as in the Liverpool shell, and also in *T. runcinata*, Watson, and *T. accisa*, Watson. This sinus is indicated

* Bulletin de la Soc. Géol. de France, t. xii. p. 154.

on the whorls by the strong arching of the lines of growth, both in *Turritella* and *Murchisonia*. But there is this difference between *Turritella* and *Murchisonia*, that, whereas the successive filling-up of the sinus in *Murchisonia* forms a distinct band, which is limited on each side by keels or by grooves, it never seems to form a distinct band on all the whorls of *Turritella*. In *T. runcinata* and *T. accisa*, however, the sinus lies between two carinæ; and, on the other hand, G. Lindström says that in *Murchisonia attenuata*, His., "near the aperture in large specimens, the transverse ornamental striæ above and beneath are confluent with the band, without any separating or bordering lines, and it continues only as an elevated ridge, sometimes not clearly distinct from the surface" ('Silurian Gasteropoda and Pteropoda of Gotland,' p. 130). The mouth of *Murchisonia* is different in form from that of *Turritella*, being longer and slightly channelled below, while that of *Turritella* is, as a rule, rounded or subquadrangular, though some species, such as *T. admirabilis*, Watson, and *T. lamellosa*, Watson, are slightly channelled at the base of the pillar. In the group *Hormotoma*, Salter says that the mouth is rounded; but I have not seen any sufficiently well-preserved specimens to show this; the specimen from which his type is taken is evidently broken at the base of the mouth.

Mr. Boog Watson also points out two remarkable features in *Turritella*, viz., the possession of a system of microscopic spirals, which covers the entire shell, and also the existence of an epidermis. If this latter had existed in *Murchisonia*, we could hardly expect any trace of it to be preserved in shells of so great an age, unless under exceptional circumstances; and I have not come across any species of *Murchisonia* sufficiently well preserved to show whether they possessed the microscopic spirals or not. Another point to be noticed is that *Turritella* possesses an operculum, and I am not aware of any opercula being found which can with certainty be referred to *Murchisonia*. There is also a greater variation in the spiral angle in *Murchisonia* than in *Turritella*, some of the shells being almost buccinoid in form.

No observations seem to have been made upon the animals of the shells with a deep sinus in the outer lip, and it would be interesting to know if there is any difference between their form and that of the animals belonging to the shells which have the outer lip merely sinuated. Thus some idea might be formed of the relative value of the sinus, with regard to making generic distinctions.

The researches of Dall upon the animals of the recent species of *Pleurotomaria* have led to their being separated from the *Halitidæ*, and being assigned to a distinct place in a family of their own. G. Lindström refers the genus *Murchisonia* to the family *Pleurotomariadæ*, which position it may be well for it to retain, until further research throws more light upon its affinities.

At present the synonymy of this genus stands as follows:—

Muricites (pars), E. F. von Schlotheim, 1820, 'Petrefactenkunde,' p. 145.

Turritella (pars), J. Sowerby, 1829, 'Min. Conch.' vol. vi. p. 125.

Buccinum (pars), J. Sowerby, 1829, 'Min. Conch.' vol. vi. p. 128.

Turritella, W. Hisinger, 1829, 'Esquisse d'un Tableau des Pétrifications de la Svède,' i. ii.

Melanopsis, F. W. Höninghaus, 1830, 'Jahrbuch für Geologie und Petrefaktenkunde, von Dr. K. C. von Leonhardt und Dr. H. G. Bronn,' p. 231.

Cerithium, J. Steininger, 1831, 'Bemerkungen über die Versteinerungen welche im Uebergangs-Gebirge der Eifel gefunden werden.'

Rostellaria, J. Phillips, 1836, 'Geol. Yorks.' vol. ii. p. 230.

Pleurotomaria (pars), J. Phillips, 1836, *ib.* p. 227.

Pleurotoma, J. Sowerby, 1839, 'Sil. Syst.' p. 612.

Schizostoma (pars), G. von Münster, 1840, 'Beiträge zur Petrefaktenkunde,' vol. iii. p. 87.

Murchisonia, A. d'Archiac et E. de Verneuil, 1841, 'Bull. de la Soc. Géol. de France,' vol. xii. p. 154.

Terebra?, J. Phillips, 1848, 'Geol. Surv. Malvern Hills,' vol. ii. pt. i. p. 357, pl. xiv. fig. 2, non Sow. 'Sil. Syst.' p. 619, pl. viii. fig. 15, nec Phil. 'Pal. Foss.' p. 99, pl. xxxviii. fig. 182.

Pleurotomaria (pars), G. & F. Sandberger, 1850-55, 'Versteinerungen des Rheinischen Schichtensystems in Nassau.'

Pleurotomaria (pars), E. d'Eichwald, 1860, 'Lethæa Rossica,' vol. i. p. 1166.

The characters of the genus may be thus defined:—Shell elongated, turreted, of numerous, gradually increasing whorls. Aperture longer than wide, with a short or truncated canal at its base; the columella is arcuated. In some species there is an umbilicus, and in others it is absent. In the outer lip there is a narrow and more or less deep slit, with parallel edges, the successive filling-up of which produces a continuous band throughout the whole length of the spire. This band is sometimes formed by a single elevated keel, or it may be flat and bounded on each side by keels or grooves. The lines of growth on the band are more or less strongly arched. On the upper part of the whorl they curve backwards to the band, and below they curve forwards again, and they indicate the successive positions of the edge of the outer lip. The *Murchisoniæ* are frequently ornamented with keels or tubercles, but they are sometimes smooth, with the exception of the band. G. Lindström ('Silurian Gasteropoda and Pteropoda of Gotland,' p. 125) states that the "oldest whorls are filled with organic deposit of calcareous matter." On p. 135 he also describes a great peculiarity in the structure of *M. deflexa*, viz., the possession of two internal, longitudinal keels, continuing throughout the length of the shell, and resembling the interior ridges of the *Nerinaæ*.

The size of the *Murchisoniæ* varies greatly, some being less than one fifth of an inch in length, while others attain a length of three or four inches.

The genus *Murchisonia* is mainly confined to rocks of Palæozoic age. The exact number of species cannot, in the present state of our knowledge, be accurately determined.

MURCHISONIA ANGULATA, Phill.? (Pl. XXIV. figs. 1, 2.)

Rostellaria angulata, ? J. Phillips, 1836, 'Geol. Yorks.' vol. ii. p. 230, pl. xvi. fig. 16 (dextra).

Non *Murchisonia angulata*, J. Phillips, 1841, 'Pal. Foss. of Devon,' p. 101, pl. xxxix. fig. 189.

Non *Murchisonia angulata*, A. d'Archiac and E. de Verneuil, 1842, 'Trans. Geol. Soc.' 2nd ser. vol. vi. p. 356, pl. xxxii. figs. 6, 7.

Non *Murchisonia angulata*, A. Goldfuss, 1841-44, 'Petr. Germ.' vol. iii. p. 25, pl. clxxii. fig. 5, a, b, c.

Non *Murchisonia angulata*, J. E. Portlock, 1843, 'Geol. Rep. Londonderry,' p. 418, pl. xxxi. fig. 5.

Murchisonia angulata, H. G. Bronn, 1848, 'Index Palæontol.' p. 747.

Murchisonia angulata, A. d'Orbigny, 1850, 'Prodr. de Paléont. stratigr.' vol. i. p. 122.

Murchisonia angulata, J. Morris, 1854, 'Cat. Brit. Foss.' p. 258.

Murchisonia angulata, ? A. Sedgwick and F. M'Coy, 1855, 'Brit. Pal. Rocks,' p. 531.

Non *Pleurotomaria angulata*, E. d'Eichwald, 1860, 'Lethæa Rossica,' vol. i. sect. ii. p. 1180.

Non *Murchisonia angulata*, J. Armstrong, J. Young, and D. Robertson, 1876, 'Cat. of the West. Scot. Foss.' p. 56.

Murchisonia angulata, J. J. Bigsby, 1878, 'Thes. Devonico-Carboniferus,' p. 325.

Non *Murchisonia angulata*, L. G. de Koninck, 1883, 'Faune du Calc. Carb. de la Belgique,' vol. viii. pt. 4, p. 18, pl. xxxiv. fig. 4.

As will be seen from the above synonymy, considerable confusion has arisen with regard to the identification of the *Murchisonia angulata* of Phillips, owing to his having described three distinct species under this name. In 1836, in the 'Geol. Yorks.' vol. ii. p. 230, pl. xvi. fig. 16, Phillips figures and describes two different Carboniferous shells as *Rostellaria angulata*; and in 1841, in the 'Pal. Foss. of Devon,' p. 101, pl. xxxix. fig. 189, he figures and describes a Devonian shell as *Murchisonia angulata*, identifying it with the shells previously described as *Rostellaria angulata*, and referring them all to the genus *Murchisonia*, d'Arch. & de Vern. This last shell is evidently quite distinct from those first described, being much smaller and the keels being differently disposed; the only point of resemblance being that both it and the shell figured on the right hand of pl. xii. fig. 16, in the 'Geol. Yorks.,' are tricariate. With regard to the first two, it is somewhat difficult to decide which should be taken as the type of the species, only one of the original specimens being in existence, and that in a very imperfect state of preservation. The Gilbertson Collection in the Natural History Museum contains a large number of the fossils described by Phillips in the 'Geol. Yorks.,' and the other specimens, I am told, have been lost. There is one shell in this collection which agrees with the left-hand figure of pl. xvi. fig. 16, and which is distinguished in the tray as the *M. angulata* figured by Phillips. It is much worn,

but it is clearly identical with the shell since described by M'Coy as *M. Verneuiliana*, var. *kendalensis*, of which there are some specimens in the Museum from Kendal. Phillips thus describes the shell: "Whorls angular, the upper ones tricarinate." I have examined a great many specimens of this shell, and it is never tricarinate. It has a broad, flattish band, about the centre of each whorl, which is solid on the body-whorl, but on some of the upper whorls it is frequently hollowed in the centre, which causes it to be formed of two small keels with a groove between them. This band represents the sinus, and is shown on the specimen in the Gilbertson Collection, where it is solid, and not grooved. In some specimens below this band there is occasionally a strong angle on the body-whorl, which either appears just above the suture on the upper whorls, or else is hidden by the whorl below; there is never any indication of a keel on the angle in any of the specimens I have examined, and in many, especially in older specimens, the angle is scarcely visible, the base being rounded, and this is the case with the specimen in the Gilbertson Collection.

With this shell is another, also from Bolland, but which is clearly distinct from it. It strongly resembles the right-hand specimen of pl. xvi. fig. 16, but is evidently not the original from which the drawing was made, as it is larger and appears to increase more slowly; but the exact spiral angle of the figure could hardly be accurately determined, as the specimen is so imperfect. This shell, however, agrees better with Phillips's brief description, being angular, and the upper whorls, which alone are preserved, are tricarinate. Since the shell represented by the left-hand figure is never tricarinate, and it has also been well described and figured by M'Coy, in the 'Brit. Pal. Foss.' 1855, p. 532, pl. 3 H. figs. 11 and 12, it would, I think, be convenient to take the other shell which is tricarinate, and which has not been elsewhere described, as the type of *M. angulata*. I have examined all the Carboniferous Gasteropoda in the Natural History Museum and in the Oxford Museum, and have also made numerous inquiries, but have not been able to obtain any more information concerning this species, neither do I know of any other tricarinate shell bearing a greater resemblance to Phillips's figure.

Many different shells have been referred by succeeding palæontologists to this species, which are not identical with either of the shells. J. E. Portlock* has erroneously identified a shell as *M. angulata*, but it differs from both of Phillips's figures by its greater spiral angle, the form of the band, and its ornamentation. A. Sedgwick and F. M'Coy † mention a shell which seems to me distinct, but it is so much imbedded in the matrix that it is difficult to make anything of it. The shell referred to as *M. angulata* in the 'Cat. of West. Scot. Foss.' p. 56, is of much smaller proportions, and is differently ornamented. A. d'Archiac and E. de Verneuil ‡

* Geol. Rep. Londonderry, p. 418, pl. xxxi. fig. 5.

† Brit. Pal. Rocks, p. 531.

‡ Trans. Geol. Soc. 2nd ser. vol. vi. p. 356, pl. xxxii. figs. 6, 7.

and Goldfuss* have referred Devonian shells to this species. That of the former differs from both of Phillips's figures; the more rapid increase of the whorls, and the absence of the keels below the band, distinguish it from the right-hand figure, while the whorls are more excavated than those of the left-hand figure. The shell described by Goldfuss, which I have examined in the Bonn Museum, increases more rapidly, the band is formed of two keels placed close together, and the whorls are more excavated. The *Pleurotomaria angulata* of E. d'Eichwald † is evidently different, from its having keels above as well as below the band, and it is also very much smaller. Of all the forms referred to this species, that described by L. G. de Koninck ‡ most resembles it. He considers his shell identical with the right-hand figure of Phillips; but I have seen his type in the Brussels Museum, and I do not think it is the same, as it increases more rapidly, the sutures are more oblique, the sinial band is formed of two keels, and the keels below the band are more numerous. There is, however, a fragment of a shell on the same tablet, which strongly resembles the tricarinata shell in the Gilbertson Collection, and may possibly be identical with it.

It would be a great advantage to have, as the type of the species, a well-defined shell such as that in the Gilbertson Collection, as its marked characteristics readily distinguish it from any other of the genus. I therefore append a fuller description. Shell elongated, turriculated, composed of numerous angular whorls. Only fragments are preserved, but a perfect specimen would probably consist of ten or more whorls. The sutures are deep, and the whorls increase gradually. Rather below the centre of each whorl there is a prominent keel, on each side of which is a narrow groove, limited by a fine line; below this prominent keel there are two smaller keels, one of which is about halfway between it and the suture, and the other appears just above the suture. The prominent keel evidently represents the sinus in the outer lip; though the lines of growth are not preserved on it, they are on the surface of the whorl, and curve back to it above, and forwards below. Above the band, the surface of the whorl is slightly concave; below it is almost vertical, sloping but little towards the suture. Mouth unknown.

(Pl. XXIV. fig. 1.) A fragment consisting of two entire whorls, and portions of two others from Bolland, is in the Gilbertson Collection in the Natural History Museum.

Length 33 millim., width of lower whorl 21 millim., height 11 millim.

In the Burrows Collection in the Woodwardian Museum there are four specimens of this shell from Settle, and there is also a large cast from the same locality, which is probably this species. All the specimens are more or less imperfect and imbedded in the matrix. Part of the base of one specimen is preserved, and on it there are three or four additional keels. The specimen figured (Pl. XXIV.

* Petr. Germ. vol. iii. p. 25, pl. clxxii. fig. 5, a, b, c.

† Lethæa Rossica, vol. i. sect. ii. p. 1180.

‡ Faune du Calc. Carb. de la Belgique, vol. viii. pt. 4, p. 18, pl. xxxiv. fig. 4.

fig. 2) is the upper part of a shell, of which five entire whorls are preserved, and a portion of another.

Length 23 millim., height of lower whorl about $5\frac{1}{2}$ millim.

Formation. Carboniferous limestone.

MURCHISONIA KENDALENSIS, M'Coy. (Pl. XXIV. figs. 3-5.)

Rostellaria angulata, J. Phillips, 1836, 'Geol. Yorks.' vol. ii. p. 230, pl. xvi. fig. 16 (sinistra).

Non *Murchisonia Verneuiliana*, L. G. de Koninck, 1843, 'Précis élément. de Géologie, par. J. J. d'Omalius d'Halloy,' p. 516.

Non *Murchisonia Verneuiliana*, L. G. de Koninck, 1843, 'Descr. des Anim. Foss. du Terr. Carb. de la Belgique,' p. 414, pl. xxxviii. fig. 5.

Murchisonia Verneuiliana, var. *kendalensis*, F. M'Coy, 1855, 'Brit. Pal. Rocks,' p. 532, pl. 3 n. figs. 11 and 12.

Murchisonia Verneuiliana, var. *kendalensis*, J. J. Bigsby, 1878, 'Thes. Devonico-Carboniferus,' p. 327.

Non *Murchisonia Verneuiliana*, L. G. de Koninck, 1883, 'Faune du Calc. Carb. de la Belgique,' p. 25, pl. xxxiv. figs. 35, 36, 37.

Shell elongated, conical, composed of from eleven to seventeen gradually increasing whorls. A little below the middle of each whorl is a broad, flat band, which represents the sinus in the outer lip. It is solid, and bounded by two fine grooves on the lower whorls, but on the upper whorls it is frequently hollowed out in the centre, forming two keels, separated by a groove. Above the band the whorl is almost flat, while below it is slightly convex. The surface of the whorls is smooth, with the exception of the lines of growth, which are strong and irregular; they curve back to the band above and forwards below; on the band they are strongly arched (fig. 3 a). On some specimens there is a strong angle on the body-whorl below the band, which is visible just above the sutures on the upper whorls. On many specimens, however, the base is rounded, and the angle is scarcely visible. There is a small umbilicus. The sutures are deep. The mouth is longer than wide, but it is not well preserved in any of the specimens I have seen.

M'Coy thought this shell might be a variety of *M. Verneuiliana*, de Kon.; but de Koninck doubts its being identical with his species, and, after the examination of his specimens at Brussels, I certainly think the differences are sufficiently marked for it to constitute a distinct species. It is a much more solid-looking shell than *M. Verneuiliana*, de Kon., the spiral angle is less, the whorls more numerous, and the form of the band is usually different; it also possesses an umbilicus.

Should it be deemed advisable to take the tricarinate shell as the type of *M. angulata*, Phill., this shell must be called *M. kendalensis*, M'Coy. Otherwise, of course, the name *kendalensis* must be dropped, and this must be termed *M. angulata*, Phill., while the tricarinate shell must have a new name.

M'Coy identifies this shell with the Devonian species *M. angulata*,

d'Arch. & de Vern. ('Geol. Trans.' 2nd ser. vol. ii. p. 356, pl. xxxii. fig. 6), which is, I think, distinct, the whorls being much more excavated, and in the type the band is grooved on all the whorls, while on the variety *a* it is much narrower.

There are about twenty-two specimens of this shell in the Woodwardian Museum; the largest is one figured by M'Coy (pl. 3 n. fig. 11). Its length is 58 millim., width of penultimate whorl 27 millim., height 12 millim. The shell is imbedded in the matrix; it consists of seven whorls, and the apex is broken. The base is rounded, and the angle shows but slightly on the upper whorls, just above the sutures.

A smaller specimen in this museum has the angle well marked on all the whorls. Only five whorls of it are preserved. A nearly perfect specimen consists of eleven whorls, and would, probably, have one or two more if the apex were entire; it is 45 millim. in length, but the surface is badly preserved. None of these specimens have the band much hollowed out in the centre on the upper whorls, it being more or less solid on all the whorls.

The specimen (Pl. XXIV. fig. 5) in the Gilbertson Collection, figured by Prof. Phillips ('Geol. Yorks.' vol. ii. pl. xvi. fig. 16, sinistra) is merely a cast consisting of two whorls, but it shows the strongly marked characteristics of this species. The band is broad and flat, and the slit in the outer lip is shown.

There are four specimens in Prof. Phillips's collection in the Oxford Museum, but none of them are well preserved. One, which is much imbedded in the matrix, consists of about seventeen whorls, and it has the strong angle below the band.

Its length is about 36 millim.

There are specimens of this shell in the Geological Society's Museum, the Museum of Practical Geology, and the Kendal Museum; and there are also one or two others in the Natural History Museum, besides that figured by Phillips.

Locality. All the above-mentioned fossils are from Kendal, with the exception of the specimen figured by Phillips, which is from Bolland.

Formation. Mountain Limestone.

Mr. Morton, Liverpool, has specimens in his collection from Porth-y-Vaen, near Oswestry, Llangollen, and Mold. He divides the Carboniferous Limestone of that district into the following lithological divisions, in descending order:—Upper Black Limestone, Upper Grey Limestone, Upper White Limestone, Lower White Limestone, Lower Brown Limestone. He finds that *M. kendalensis*, M'Coy, ranges throughout the series with the exception of the Upper Black Limestone. It occurs in the Lower Brown and Upper Grey at Llangollen, in the Upper White near Oswestry, and in the Upper Grey near Mold.

In the Wood Collection in the York Museum there is also a specimen from Oswestry (Pl. XXIV. fig. 4). It consists of about eight whorls, and the apex is broken. The band on the lower whorls is solid, but on the upper it is grooved and composed of two keels.

It exhibits a slight variation, there being two fine lines on the part of the whorl above the band. The angle is well developed on the lower part of the whorl. Umbilicus distinct. Mouth broken. Length 36 millim., width of body-whorl $19\frac{1}{2}$ millim.

Formation. Mountain Limestone.

MURCHISONIA VERNEUILIANA, de Kon. (Pl. XXIV. figs. 6-8.)

Murchisonia Verneuiliana, L. G. de Koninck, 1843, 'Précis élém. de Géologie, par J. J. d'Omalius d'Halloy,' p. 516.

Murchisonia Verneuiliana, L. G. de Koninck, 1843, 'Descr. des Anim. Foss. du Terr. Carb. de la Belgique,' p. 414, pl. xxxviii. fig. 5.

Murchisonia Verneuiliana, H. G. Bronn, 1848, 'Index Palæontol.' p. 748.

Non *Murchisonia Verneuiliana*, var. *kendalensis*, F. M'Coy, 1855, 'Brit. Pal. Rocks and Foss.' p. 532, pl. 3 H. figs. 11 and 12.

Murchisonia Verneuiliana, L. G. de Koninck, 1877, 'Recherches sur les Foss. Pal. de la Nouvelle-Galles du Sud,' p. 119, pl. xxiii. fig. 15.

Murchisonia Verneuiliana, J. J. Bigsby, 1878, 'Thesaurus Devonico-Carboniferus,' p. 327.

Murchisonia Verneuiliana, De Kon., 1883, 'Faune du Calc. Carb. de la Belgique,' p. 25, pl. xxxiv. figs. 35, 36, 37.

Shell conical, composed of from eight to ten angular whorls. A little below the centre of each whorl there are two strong keels, between which lies the sinual band; the band is wide and sunk between the two keels. The lines of growth are distinct, curving back to the band above and coming forward again below; on the band they are arched, but not so strongly as in *M. kendalensis*, M'Coy. The surface of the whorls is almost flat, being but slightly convex. The base of the last whorl is convex; it has a slight angularity a little below the band, which is hidden by the suture on the upper whorls. Prof. de Koninck says that the last whorl has a tendency to become detached from the preceding whorls. The sutures are deep. The mouth is a little longer than wide. The columella is simple, and there is no umbilicus. The surface of the whorls is generally ornamented with fine spiral striæ. The largest of the specimens in the Woodwardian Museum has these spiral lines well preserved. Another only shows two of the strongest lines above the band and two below; the keels bounding the band of this specimen also appear to be slightly undulating, but this may arise from wear, as the surface of the shell is much worn. The specimen figured by de Koninck has only the spiral lines below the band.

De Koninck says that this shell differs from *M. plicata*, Goldf., by the depth of its suture and also by the absence of the keel on the base. In the type of *M. plicata*, Goldf., which I have examined in the Bonn Museum, there is a still greater difference, for the upper margin of the whorl is nodulose at the suture, the keel below the

band on the body-whorl is also nodulose, the surface of the shell is plicated, and the keels bounding the sinual band are somewhat undulating, as in *M. Humboldtiana*. In 1843, de Koninck ('Descr. des Anim. Foss. du Terr. Carb. de la Belgique,' p. 414) considered this shell identical with a Devonian one figured and described by A. d'Archiac and E. de Verneuil as *M. angulata* ('Trans. Geol. Soc.' 2nd ser. vol. ii. p. 356, pl. xxxii. fig. 6); but in 1883, 'Faune du Calc. Carb. de la Belgique,' p. 25, he says he considers them to be distinct species.

This shell bears a strong resemblance to the Devonian *Pleurotomaria angulata* of Sandberger ('Die Versteinerungen des Rheinischen Schichtensystems in Nassau,' p. 204, pl. xxiv. fig. 19).

I am not aware of its having been described as British before.

There are four specimens of this species in the Woodwardian Museum. The length of one (Pl. XXIV. fig. 6), consisting of eight whorls, is 21 millim., width of body-whorl 13 millim., height of body-whorl 9 millim. A portion of a larger shell (Pl. XXIV. fig. 7), consisting of three whorls, has a length of 21 millim.; the width of the body-whorl is 14 millim.; height of body-whorl 15 millim. The other two specimens are much smaller.

Locality. Settle.

Formation. Mountain Limestone.

In the Museum of Practical Geology there are three very small specimens, which are of about the same size as the smallest I saw in the Brussels Museum. The length of that figured on Pl. XXIV. fig. 8 is 7 millim., width of body-whorl nearly 4 millim. It is on the same piece of rock as *Pleurotomaria Griffithii*, de Kon.

Locality. Abergele.

Formation. Mountain Limestone.

The other two specimens in this Museum are from the Mountain Limestone of Narrowdale and the Great Ormes Head.

MURCHISONIA PYRAMIDATA, sp. nov. (Pl. XXIV. fig. 9.)

Shell elongated, whorls angular, gradually increasing. Only four whorls and a portion of a fifth are preserved; there would probably be ten or twelve if the shell were entire. There is a prominent rounded keel situated about two thirds down each whorl, which evidently represents the sinual band, though no lines of growth are preserved on it. These lines curve backwards to it above and slightly forward again below; they are fine and faint. The surface of the whorls both above and below the band is slightly concave, and the base is convex. The form of the mouth and columella is unknown, as the base is broken. The lower part of the whorl is covered with fine spiral threads, thus disposed:—immediately below the band is a deep groove, then a strong thread, three or four finer ones, another strong thread which is about midway between the band and the suture, below this there are two or three fine ones on the upper whorls, but they are more numerous on the base, which is covered with them. These spiral lines are slightly beaded; they are probably rendered so by the crossing of the lines of growth. Above

the band there is a spiral thread about two thirds below the suture, and immediately below the suture there is another fine thread on the body-whorl, but it is not preserved on the other whorls.

There is only one specimen of this shell in the Gilbertson Collection in the Natural History Museum (no. G. 234). The length of the four and a half whorls is 20 millim., width 12 millim.

The shell has a slight resemblance to *M. Archiaciana*, de Kon., but the whorls are not so convex, the band is narrower and more prominent, and the spiral lines below the band are beaded and more numerous. Perhaps the general form most nearly approaches that of *M. spirata*, Goldf., the type of which I have seen at Bonn; but the band of this species is formed of two keels, separated by a small groove, and there are only two spiral lines below it, instead of the numerous lines of *M. pyramidata*.

Locality. Bolland.

Formation. Carboniferous Limestone.

MURCHISONIA ZONATA, sp. nov. (Woodcuts, figs. 1, 2.)

Shell conical; whorls convex, separated by deep sutures. There are only two specimens of this shell, and neither of them is entire, but three whorls being preserved of each, and one specimen is a

Fig. 1.—*Murchisonia zonata*,
Donald. Nat. size.

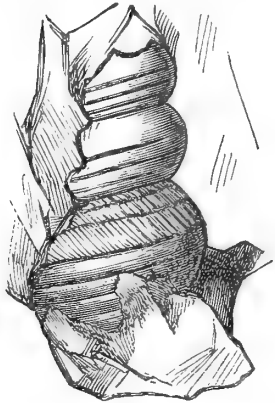
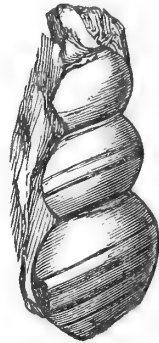

Fig. 2.—Cast of *Murchisonia*
zonata, Donald.



From the Mountain Limestone of Narrowdale.

mere cast. The sinual band is situated about the middle of each whorl; it is broad and flat, and is not raised above the surface of the whorl; it is bounded by two grooves. Below the sinual band there are two narrower and slightly convex bands, separated by grooves, and on the body-whorl there are two or three additional bands and grooves. On the upper part of the whorl there are two very shallow grooves, one of which is about midway between the suture and the sinual band, and the other is just below the suture. The lines of growth are only preserved on the upper part of the body-whorl, where they are distinct and curve backwards to the sinual band. The mouth is imbedded in the matrix.

Length of the more perfect specimen 8 millim., width $5\frac{1}{2}$ millim. Length of the cast 10 millim. These two shells are in the Carr Collection in the Museum of Practical Geology.

This species bears some resemblance to *M. Sedgwickiana*, de Kon., but it is more elongated, the bands and grooves are not so evenly disposed, and it is also much smaller. From *M. subsulcata*, de Kon., it is distinguished by the greater number of grooves possessed by that species. The American form, *M. terebriformis*, Hall, most nearly approaches it; but it is ornamented with elevated spiral striæ below the band instead of with flat bands.

Locality. Narrowdale.

Formation. Mountain Limestone.

MURCHISONIA SPHÆRULATA, sp. nov. (Pl. XXIV. fig. 10.)

Shell elongated, conical, composed of numerous convex whorls. The whorls are rendered slightly angular in the middle by the sinual band. The band is broad and flat, and bounded by two narrow grooves; there is a wider and shallower groove in the centre of it. Below the band there are five or six spiral lines; they are somewhat indistinct, and are slightly reticulated with the lines of growth. The lines of growth are strong, and curve backwards to the band above, and forwards below; they are arched on the band. The upper part of the whorl is smooth. The mouth is longer than wide.

There is but one specimen of this species in the Museum of Practical Geology, and it has only four whorls preserved.

Length 17 millim., width of body-whorl 8 millim., width of penultimate whorl 7 millim.

This shell is more elongated than *M. zonata*, and it is ornamented with fine spiral lines instead of with flat bands. It is larger than *M. terebriformis*, Hall, the whorls increase more slowly, and the lines below the band are very fine and more numerous, instead of being raised spiral threads.

Locality. James's Cleugh, King Water, Cumberland.

Formation. Lower Carboniferous.

MURCHISONIA TENUISSIMA, sp. nov. (Pl. XXIV. fig. 11.)

Shell very elongated, turriculated. A perfect specimen would possess from ten to twelve whorls. Whorls angular, and each ornamented with six spiral keels. Three of these keels are placed rather close together about the middle of the whorl and form the sinual band; the central keel is a little finer than the others. Above the band a fine keel lies just below the suture, and below the band there are two keels, the lowest of which appears just above the suture on the upper whorls. On the body-whorl there is also a very fine thread between the band and the uppermost keel. The lines of growth are strong and very distinct; they curve back to the band above, and forward below; they are arched on the band. The specimen is imbedded in the matrix, and the body-whorl is broken away from the rest of the shell.

There is only one specimen in the Museum of Practical Geology; its length is 10 millim.

The only shell which this resembles is *Turritella? sulcifera*, Portl., from which it differs by the form of the band, which is formed of only two keels in *T. sulcifera*, and the space above the band is greater and slopes more gradually than in that species.

Locality. Wark, Northumberland.

Formation. In beds on about the same horizon as the top of the Mountain Limestone and the base of the Yoredales.

TURRITELLA? SULCIFERA, Portl. (Pl. XXIV. fig. 12.)

Turritella? sulcifera, J. E. Portlock, 1843, 'Geol. Rep. Londonderry,' p. 420, pl. xxxi. fig. 11.

A minute shell in the Museum of Practical Geology is considered, but not without doubt, to be the specimen figured and described by Gen. Portlock. He describes it as a "minute shell, having ten whorls in less than one third of an inch; it is narrow and elongated, and has its whorls marked by spiral sulci, bounded by strong spiral ridges, of which there are four on each whorl." His figure is too imperfect to be of any assistance in the way of identification; but the specimen in the Museum agrees with the description, with the exception that there is a fifth keel on the lower whorls, where it appears just above the suture, and on the uppermost whorls it is hidden below the suture. The apex is broken, but this may have been done since Gen. Portlock's description was written. Thus only seven whorls remain. Of the five keels with which the whorls are ornamented the central and that next above are the strongest, the uppermost is the slightest, and the space below the uppermost keel is the widest. This shell bears a strong resemblance in its characteristics to species of the genus *Murchisonia*, but as neither the mouth nor the lines of growth are preserved, it cannot with certainty be referred to this genus. Should it be a *Murchisonia*, the sinus probably lies between the strongest keels. I have seen no shell resembling this species in the Irish collections in Dublin; and this is the only specimen I know of that comes near to Gen. Portlock's description. Length of the seven whorls 5 millim., width of the penultimate whorl under 2 millim.

Locality. Cullion, co. Derry.

Formation. Shales in the Lower Limestone. This is probably about the same horizon as the lower part of the Mountain Limestone.

NOTE.—In concluding this paper I must acknowledge how greatly I am indebted to Prof. Hughes, Prof. Prestwich, Mr. Etheridge, Mr. E. T. Newton, Prof. Schlüter, Dr. Purves, and others, for affording me every facility in studying the collections in the different museums with which they are connected. The Rev. G. Crewdson has also kindly lent me specimens from the Kendal Museum. I am also under great obligations to Mr. Goodchild for revising these notes and assisting me in many ways.



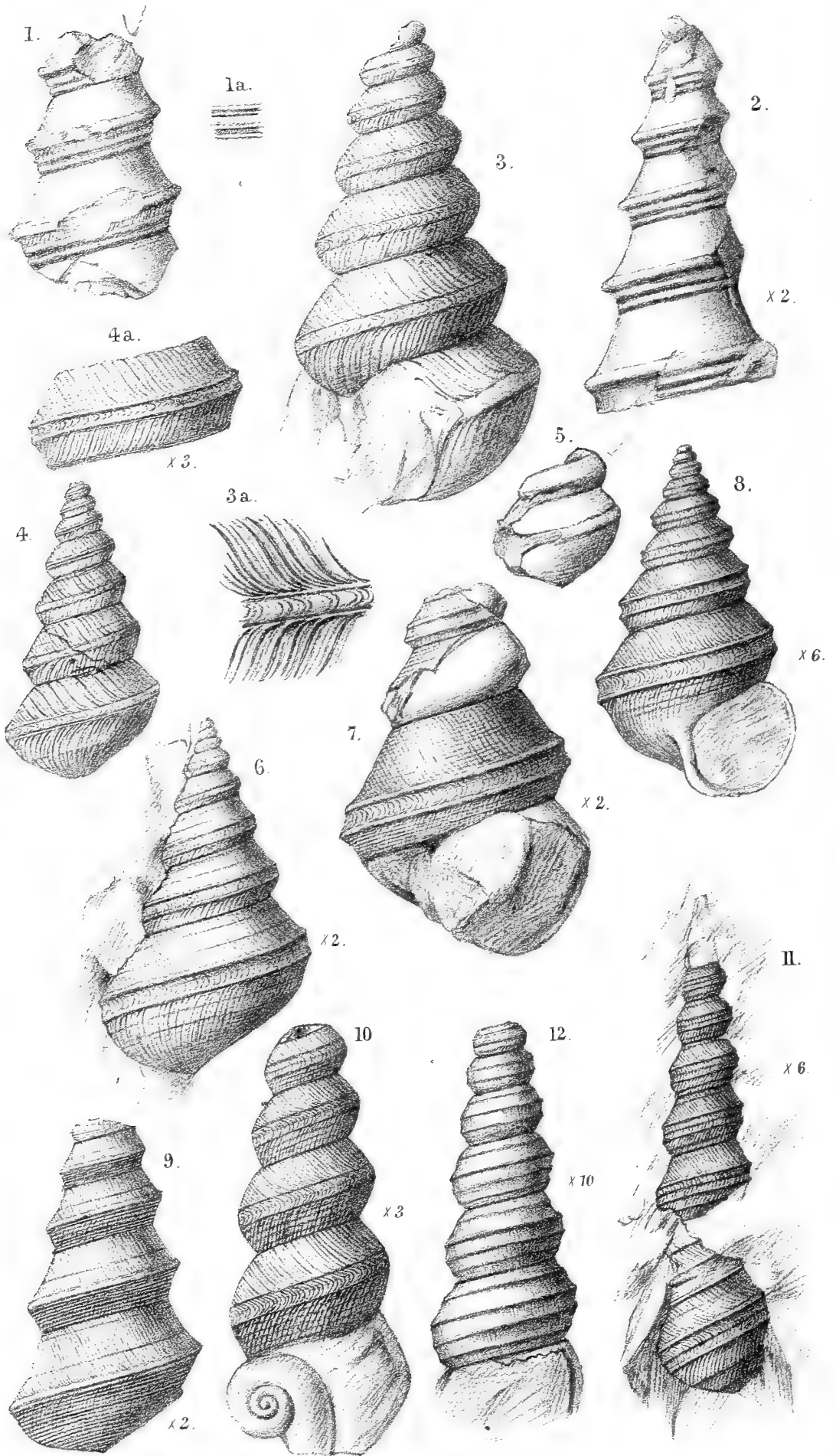

EXPLANATION OF PLATE XXIV.

- Figs. 1, 1*a*. *Murchisonia angulata*, Phill.? Bolland. Nat. size. 1*a*, band enlarged.
 2. ———. Settle. $\times 2$.
 3, 3*a*. ——— *kendalensis*, M'Coy. Kendal. Nat. size. 3*a*, band enlarged.
 4, 4*a*. ———. Oswestry. Nat. size. 4*a*, fourth whorl, $\times 3$.
 5. ———. Bolland. Nat. size.
 6, 7. ——— *Verneuiliana*, de Kon. Settle. $\times 2$.
 8. ———. Abergele. $\times 6$.
 9. ——— *pyramidata*, sp. n. Bolland. $\times 2$.
 10. ——— *sphærulata*, sp. n. James's Cleugh, King Water, Cumberland. $\times 3$.
 11. ——— *tennissima*, sp. n. Wark. $\times 6$.
 12. *Turritella?* *sulcifera*, Portl.? Cullion. $\times 10$.

DISCUSSION.

The PRESIDENT remarked that while there was little in such a paper as that before the Meeting which could have interested the Fellows had it been read in full, the paper was nevertheless of great value as containing many most useful observations upon a very important group of Palæozoic fossils.

Mr. GOODCHILD stated that Miss Donald had not only studied most carefully the fossils of the northern district in which she resides, but she had also pursued her researches during visits to many museums in this country and also on the continent of Europe.

43. NOTES on some POLYZOA from the LIAS.

By EDWIN A. WALFORD, Esq., F.G.S. (Read June 23, 1887.)

[PLATE XXV.]

THE Polyzoa of the Lias at present known seem to be restricted to the genera *Stomatopora*, *Proboscina*, *Spiropora*, *Neuropora*, *Lichenopora*, *Semimulticlausa*, *Diastopora* (*Berenicea* being by later systematists classed with the *Diastopora*), and the genus it is now proposed to add, viz. *Tubulipora*.

HISTORY.

In 'Morris's Catalogue of British Fossils,' published in 1854, there is no record of Polyzoa from the Lias; but the steadily accumulating records of palæontological work enabled Mr. R. Etheridge, F.R.S., in 1882, in his Presidential Address to the Geological Society* to tabulate three genera and six species. Vine† in the British Association Report for the same year reviews but three genera and four species. French and German authors have, however, increased the number. Although Deslongchamps‡, having turned over his *Neuropora* to the Spongidæ, mentions but two genera, representing as many species, Haime§ can add but one species more, saying, at the end of his admirable monograph, "on ne connaît encore aucun bryzoaire dans le lias moyen ni dans le lias supérieur." Terquem and Piette|| in 1865 recognize, in addition to some forms previously described by Fromentel¶, three genera new to the Lower Lias, and add also six new species: a few years later Dumortier** catalogues in his list of fossils from the several divisions of the Lias of the Rhone basin seven species, of which four are new. Their occurrence in the Lias of Germany appears to be very rare, for Quenstedt and Opperl mention but one species.

The rarity of Polyzoa in the Lias of England has been pointed out by Prof. Tate†† when describing a new species of *Spiropora* from the Upper Lias (Leptæna-beds) of May, Normandy. To that species (*Spiropora liassica*) he refers other Polyzoa from the Middle Lias of King's Sutton, Northamptonshire, in Mr. Beesley's collection.

* "On the Analysis & Distrib. of Brit. Jurass. Foss.," by R. Etheridge, F.R.S., &c., Quart. Journ. Geol. Soc. vol. xxxviii. Proc. p. 152 (1882).

† Third Report on Foss. Polyzoa (Jurass. sp., Brit. area only) by Dr. H. C. Sorby, F.R.S., and G. R. Vine, Brit. Assoc. 1882.

‡ 'Études Jurass. Inf. de la Normandie,' par M. E. Eudes-Deslongchamps, Paris and Caen, 1864.

§ "Descr. des Bryozoaires Foss. par Jules Haime," Mém. Soc. Géol. de France, 2^e série, t. v. (1854).

|| Terquem & Piette, "Lias inf. de l'est de la France," Mém. Soc. Géol. de France, 2^e série, t. viii. p. 124.

¶ Fromentel, E., "Pal. de la Côte-d'Or," Mém. Soc. Géol. de France, 2^e série, t. vii. p. 91.

** Dumortier, E., "Études Pal. sur les Dép. Jurass. du Bassin du Rhône," Paris, 1864-1874.

†† Tate, R., "On some New Liassic Fossils," Geol. Mag. dec. 2, vol. ii. p. 205.

Amongst some specimens from the latter locality in my own cabinet are numerous examples which both Mr. Vine and myself consider to be distinct from Tate's type; and to the consideration of them and associated forms these notes are directed.

Inasmuch as, with the Cyclostomatous Polyzoa, the simple cell-structure makes it necessary for the student to adopt in great degree zoarial growth as a means of classification, there occasionally occur forms, as in the species under notice, which find no secure resting-place under any family roof. In other examples, from the Inferior Oolite, this difficulty is equally apparent.

TUBULIPORA INCONSTANS, sp. nov. (Pl. XXV. figs. 1-9 & 12.)

Rarely does a form present more varying and erratic modes of growth than the species before us. Whilst some colonies have a foliaceous habit (fig. 1), others are cylindrical (fig. 5), after the fashion of *Diastopora Lamourouxi*, M.-Edw., though the predominant form of growth is erect, ramose, and cylindrical (figs. 4 and 7). In some instances from the flattened lobes spring branches cylindrical or but slightly flattened (fig. 8), and occasionally the colony is adnate.

The zoëcia are long, with proximal extremities free for as much as $\frac{1}{3}$ or $\frac{1}{4}$ of their whole length (fig. 7), or else have but a slight degree of projection from the stem. The peristomes are circular (fig. 2), opening irregularly over the zoarium, and are about two thirds of the diameter of the zoëcia. Bright and distinct purple lines separate the cells in marked contrast to the fawn-colour of the cells themselves. Covering the whole surface are tubular papillæ or minute projecting tubes (surface-pores), arranged occasionally in transverse or subspiral lines. The pores seem to communicate with the interior of the cell and are apparently connected with each other by delicate tubes (fig. 3), which traverse the outer wall mainly in the direction of the length of the cell. These surface-pores, common to many families of the Polyzoa, are almost identical with the markings upon some Italian *Proboscince*.

The zoëcia of both foliaceous and cylindrical forms bear just *within* the peristome solid circular closures (fig. 2). Though there appear to be no absolutely terminal closed cells, yet, immediately below the extremity of the newest branch, cells are often provided with the closures—a point rather against the theory of their development being only on old and worn-out cells. The position of this calcareous cover *below* the orifice tells also somewhat against its being considered a movable operculum. In its centre is a funnel-shaped perforation measuring about one third of the width of the whole, and there are also a few scattered minor perforations. Frequently a slight constriction of the zoëcial tube may be noted below the position of the closure.

Prof. Busk * figures species of *Pustulopora* and *Patinella* with the zoëcial tubes closed with calcareous lids, which are placed quite

* 'The Polyzoa of the Crag,' by G. Busk, pl. xviii. fig. 2, pl. xix. fig. 1, Mem. Pal. Soc.

close to, though within, the orifice. In an able critique by Mr. F. D. Longe*, examples of Jurassic *Diastopora* are shown with the closures in a terminal position, and hence the author infers that there is no substantial difference between them and the opercula of the Chilostomata.

Prof. D. Brauns † boldly advocates the establishment of an operculate division in the order Cyclostomata, and places under that head the genus *Elea*, with *Elea foliacea* as his type.

Mr. Waters ‡, working upon Recent and Tertiary material, points out that "The most usual position for the calcareous plate which closes the tube would seem to be about the point where the zoöcial tube rises free from the zoarium." In the genera *Hornera*, *Entalophora*, and *Reticulipora*, figured by him, the closures are shown to be so far within the tube as to almost negative the question of their identity with movable opercula. A section of *Neuropora damicornis* (Lamx.) in my collection shows each zoöcial tube with numerous closures or septa, none of which, however, are near the mouth.

The zoöcial surface is not only transversely wrinkled, but also shows some traces of what may possibly be spines. This feature is, however, very obscure, for the surface of well-preserved specimens is often covered with a close and exceedingly delicate calcareous network (fig. 6), partly hiding even the dark lines of the zoöcial walls. A similar network of fine threads occurs upon small shells found in the same beds.

The oöcia are rare and consist of irregular inflations of one or two cells (fig. 4). In one instance the oöcium, apparently an enlarged simple cell, is provided with a smaller opening in addition to the ordinarily large mouth. Other forms of oöcia are external semiglobose chambers enveloping the free parts of one or two cells (fig. 9). The study of this species brings home the fact, so frequently acknowledged by specialists, of the unsatisfactory nature of the classification of the Cyclostomatous Polyzoa; and one cannot put aside the thought that had a few fragments only of it been found, one portion might have done duty as a foliaceous *Diastopora*, another as an *Entalophora*, whilst a third would possibly have been referred to *Tubulipora*. Notwithstanding some superficial resemblance to *Diastopora cervicornis* and *D. Lamourouxi*, M.-Edw., the exceptional length of the zoöcia and their partial freedom sufficiently remove the King's-Sutton species from the *Diastopora*, irrespective of its *Tubulipora*-like habit of growth. To the *Spiropora* the foliaceous and adherent forms present an insuperable barrier (though it must not be overlooked that *Cricopora abbreviata*, Mich., is figured with a flattened base from which the branches spring). The cell-closures do not, as yet, seem to have been discovered either

* Longe, F. D., "On the Relation of the Escharoid Forms of Oolitic Polyzoa," &c., Geol. Mag. dec. ii. vol. viii. p. 23.

† "Die Bryozoen des mittleren Jura der Gegend von Metz," von D. Brauns, in Halle. Zeitschr. d. deutschen geolog. Gesellschaft, Jahrg. 1879.

‡ Waters, A. W., "Closure of the Cyclostomatous Bryozoa," Linn. Soc. Journ. vol. xvii. p. 400.

in the *Spiroporæ** or the *Tubuliporæ*; yet, notwithstanding this, I think the species finds best, though insecure, place with the latter group. It has the long and partly free zoœcia of *Tubulipora*, and an inconstant habit of growth common to the genus. As a provisional name therefore seems to be necessary, I would suggest that of *Tubulipora inconstans*. The transverse line or septum formed by the two layers of cells when back to back, as in the foliaceous forms (fig. 12), has somewhat of a Diastoporoid look.

Through the courtesy of Mr. Newton I have been enabled to examine the type specimens of Tate's *Spiropora liassica* at the Jermyn-Street Museum, and it appears to me that the *Spiropora*-like branches of *Tubulipora inconstans* are not only provided with a smaller number of zoœcia to form an average-sized zoarium, but the zoœcia are also much longer and somewhat broader. Their disposition is irregular, whereas *S. liassica* has a regular arrangement of the peristomes in each annulation and, moreover, the ordinary erect colonial growth of the *Spiroporas*.

Horizon and Locality. From the Marlstone Rock-bed, zone of *Ammonites spinatus*, of the Middle Lias, King's Sutton, Northamptonshire, also from the Transition bed between the Middle and Upper Lias at Appletree, near Banbury, and at Badby, near Daventry.

Associated with the species above described are two others in which, though the colonial and zoœcial forms are essentially different from it, the structural details are so closely mimicked as to make their reference to other genera a matter of doubt. I have therefore described and figured them, but have left the nomenclature until further evidence shall show their precise relationship.

Zoarium erect, uniserial, commencing as a straight or slightly undulating and often flattened simple tube, then dilating and throwing off a branch right and left, without, however, any cell-opening at the node, though a faint line of fusion is visible in the primary stem. The secondary branches or zoœcia dilate also at each succeeding node where the single cell opens and a fresh zoœcium begins. The branches diverge at an angle of from 45° to 50°, and the cell opens at a little distance above the point whence the new one has sprung. Peristomes circular, in diameter of the normal width of the zoœcium. The surface pores and subsidiary tubes are of the same character as in *Tubulipora inconstans*. (Pl. XXV. fig. 11.)

Though out of the few examples collected some are erect, others, on the contrary, show some portion of the zoœcium to be flattened as if the colony was partially adherent, and between this and the next group there seem to be connecting links.

Horizon and Locality. From the Middle Lias, zone of *Ammonites spinatus*, King's Sutton.

Similar forms occur in the Inferior Oolite of Dorsetshire.

* Mr. Waters (Quart. Journ. Geol. Soc. vol. xliii. p. 340, 1887) describes and figures *Entalophora wanganuiensis* with closures, and I have now Inferior Oolite species similarly provided.

STOMATOPORA * sp. (Pl. XXV. fig. 10.)

Zoarium adnate, dilated at point of attachment, flattened or very convex. Zoœcia uniserial, large and frequently of extraordinary length (2 millim.), the free part then comprising two thirds of the length of a single zoœcium and springing from the point of adherence at an angle of 45° , or, in some cases, almost vertically. The unattached portion of the cell is also sinuous and coarsely wrinkled, and though the surface-pores are throughout of the same type as in the species already described, they are apparently fewer in number than upon the adherent part.

This form, so like a *Stomatopora*, is distinguished from any described species of that genus by the greater length of the free parts of the zoœcia, and also by their size and the distance from peristome to peristome.

Horizon and Locality. From the Middle Lias, zone of *Ammonites spinatus*, King's Sutton.

ADDENDUM [September 16, 1887].

The quarry from which these Polyzoa have been collected is noted as having yielded many beautiful specimens of both Mollusca and Corals, and amongst the rarer forms mention may be made of *Spiriferina oxygona*, E. Desl., *Pecten textorius*, Schl., *Mytilus aviothensis*, Buv., *Perna lugdunensis*, Dumort., *Pleurotomaria mirabilis*, E. Desl., *Thamnastreæ Etheridgii*, Tomes, and *Astrocœnia*, sp. The Foraminifera are well represented, the examples of *Dentalina*, *Nodosaria*, *Marginalina*, *Vaginulina*, and *Cristellaria* being exceptionally large, whilst species of *Fronicularia*, *Glandulina*, and other genera occur also. An interesting addition to our fossil fauna is made by the discovery of small forms of Calcispongiæ, which I have submitted to so eminent a specialist as Dr. Hinde. He writes not only that their condition is simply marvellous, but that they belong probably to the existing group of the Leuconidæ, examples of which do not seem to have been found previously in a fossil condition. He reserves their description for his forthcoming monograph.

EXPLANATION OF PLATE XXV.

- Fig. 1. *Tubulipora inconstans*, sp. n., foliaceous form. $\times 12$.
2. The same, zoœcium with closure. $\times 40$.
3. The same, worn zoœcia showing surface-pores and subsidiary tubes. $\times 45$.
4. The same, erect, *Spiropora*-like form, showing oœcia. $\times 20$.
5. The same, cylindrical form. $\times 25$.
6. The same, showing fine threads upon the surface of the cells. $\times 25$.
7. The same, erect form, showing free proximal ends of zoœcia. $\times 13$.
8. The same, flattened form of irregular growth, throwing off cylindrical branches. $\times 14$.
9. The same, showing oœcia. $\times 30$.
10. *Stomatopora*, sp. $\times 25$.
11. Species not determinable. $\times 25$.
12. *Tubulipora inconstans*, end of flattened lobe. $\times 30$.

* I have since found the same species in the Inferior Oolite of Dorset. Its well-marked distinction from other forms will induce me to name it *Stomatopora elongata*.

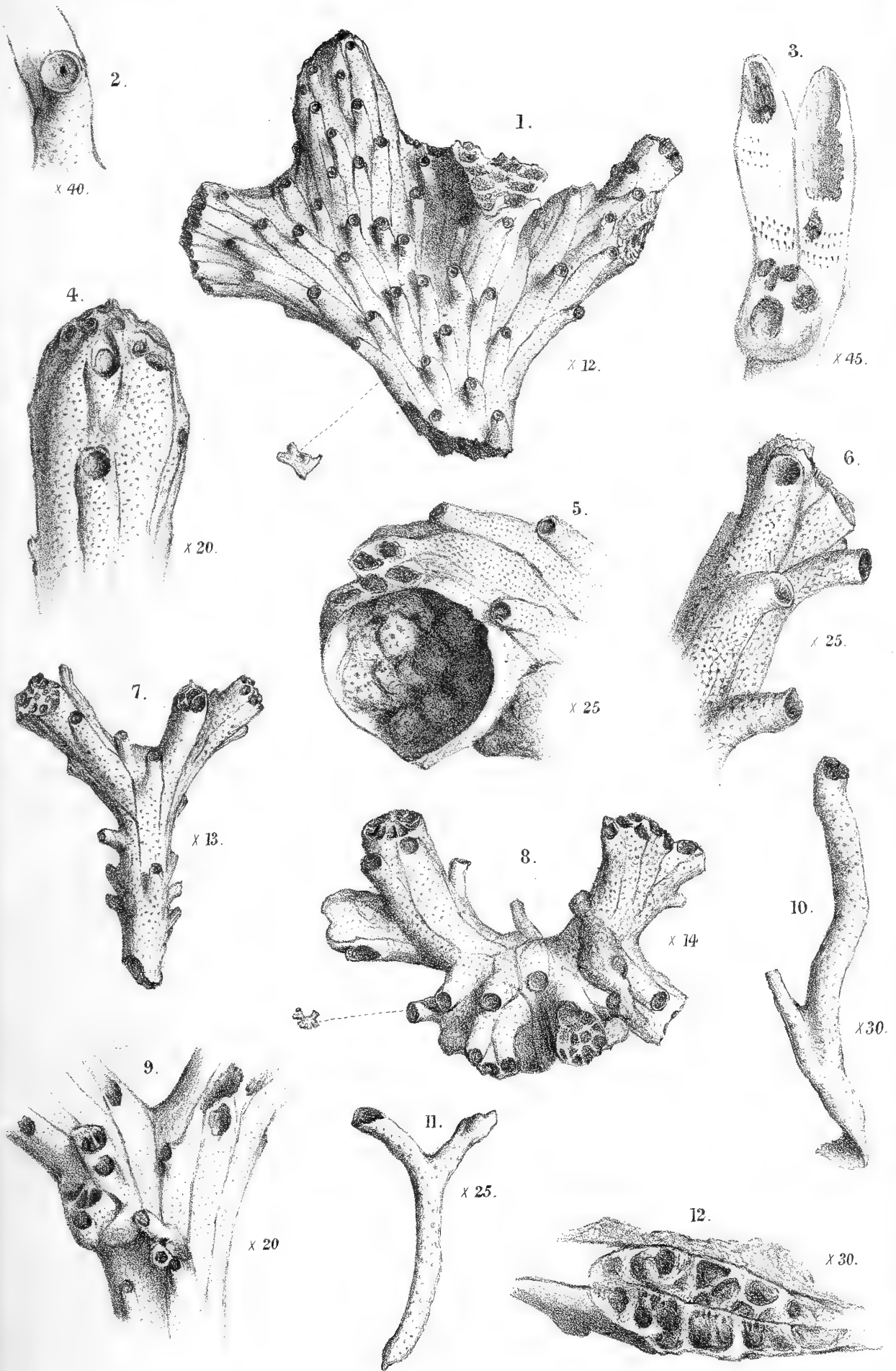

44. *On the SUPERFICIAL GEOLOGY of the SOUTHERN PORTION of the WEALDEN AREA.* By J. VINCENT ELSDEN, Esq., B.Sc. Lond., F.C.S. (Read June 23, 1887.)

[Communicated by the President.]

INTRODUCTORY.

MORE than thirty years have elapsed since Sir Roderick Murchison published his well-known paper "On the Distribution of the Flint Drift of the S.E. of England on the Flanks of the Weald and over the Surface of the North and South Downs"*. The observations contained in that paper are stated by the author to be far from complete, and offered chiefly to elicit further inquiry and discussion. Since that time the 6-inch Ordnance maps of this area have been completed, and the superficial deposits of a considerable portion of the district mapped by the Geological Survey. No detailed description, however, of the nature and extent of the various drift-gravels of the southern portion of the Wealden area has been published since the completion of the accurately contoured maps of the Ordnance Survey. Apart from the importance attaching to any new investigations relating to the question of Wealden denudation, the superficial deposits of the area under consideration are of interest on account of their extremely scanty occurrence, many of the drift-beds to be hereafter described consisting of nothing more than a thin coating of flinty loam, or of the mere fragmentary remains of old beds of gravel. But in all cases the limits of these beds are sharply defined, and their relation to the present contours easily established. The following observations are offered as the result of a somewhat detailed examination of a considerable part of this area during the year 1886, but the investigation has of necessity been limited to the district lying between the central dome and the chalk escarpment of the South Downs.

It will be convenient in the treatment of the subject to consider each river-basin separately.

The Arun Basin.—In the higher parts of the Arun valley it has already been shown that the bills are capped by patches of angular chert, containing no flint, and representing probably the remains of the Lower Greensand escarpment when it reached further south than now †. Around Chiddingfold, Fisherlane, and Dunsfold Green there occur frequently thin patches of loam with Greensand pebbles, sometimes cemented into a conglomerate. This deposit occurs indifferently on the hills and in the valleys. On approaching Slinfold we find a good deal of true river-gravel on the Weald Clay, containing *flints*, pebbles of Wealden sandstone, and Lower Greensand ironstone and chert. On the central nucleus of Hastings beds itself flints occur at Amy's Mill, near Horsham, where Mr. Drew obtained a single fragment of flint from the gravel ‡. I examined

* Quart. Journ. Geol. Soc. vol. vii. p. 349.

† Topley, 'Geology of the Weald,' p. 200.

‡ *Ibid.*

this section with some care, in company with Mr. P. R. Head. About 8 feet of stratified gravel, consisting of waterworn Wealden fragments, with intercalated beds of sand, occur in some pits near Amy's Mill Bridge, at no great distance from the river, and only 20 or 30 feet above its level. After a careful search as many as seven angular fragments of flint were found, so thin and sharp at the edges as to render it improbable that they had ever been transported very far by ordinary river-action. A few of these angular flints may be found lying on the surface of the ground in the fields to the south of Amy's Mill Farm. This occurrence of flints on the flanks of the central dome is extremely rare. Murchison, in fact, states that flints do not occur in this portion of the Arun valley.

During the remainder of its course through the Weald-Clay country there are few deposits of any remarkable extent beyond loams, sometimes containing concretionary ironstone, which is often ploughed up, and was originally smelted. Between Rudgwick and the Lower Greensand escarpment these loams occur on both sides of the river, greatly improving the agricultural value of the land. In these loams angular fragments of chert are found in great abundance, together with some chalk flints.

To the south of the Lower Greensand escarpment, however, there are extensive deposits of angular gravel, resting chiefly upon the Lower Greensand, but occasionally also upon the Gault and Upper Greensand formations. These beds appear to consist of two distinct kinds. In the first place, there is a true river-gravel, which occurs in patches along the course of the Rother between Pulborough and Cowdry Park; but this lower river-gravel is sometimes difficult to separate from other extensive patches occurring at much greater heights above the present level of the river.

Sections of the lower gravel are to be seen in several places in the railway-cutting between Coates and Pulborough. At Fittleworth from 5 to 10 feet of gravelly loam is seen, containing whole and broken flints, both angular and subangular, together with ironstone and chert, and occasionally a rolled pebble of flint. The junction of the Lower Greensand is often marked by the presence of large masses of ironstone; but stratification is only very slightly indicated. In some places the gravel has intercalated beds, 4 or 5 feet thick, of sandy loam, with only a few flints. From the abundance of flints on the surface this bed of gravel appears to extend over the whole area between Coates Common and Coldwaltham to above the 100 feet contour. At Hardham a pit shows about 6 feet of sandy gravel, with very marked stratification, the beds being sometimes violently contorted, and the same gravel is seen again at Hardham Tunnel. All these gravels agree in containing stones of very different sizes, from large unbroken flints to very small, sharp, shattered fragments, and chert and ironstone are very abundant. On the north bank of the Rother this gravel is again seen at Lower Fittleworth, where I procured a fragment of bone. On the very summit of Fittleworth Common, above the 100 feet contour, there are several pits showing good sections of gravel with a rude and contorted

stratification, and often penetrating the Lower Greensand in huge pockets. The diagram (fig. 1) shows an upper and lower bed of

Fig. 1.—Section on Fittleworth Common.

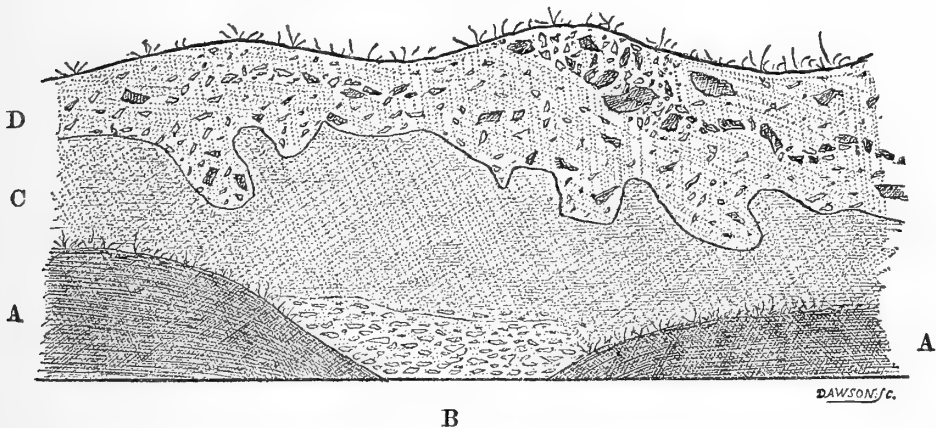

D. Angular gravel.
C. Loam.

B. Angular gravel.
A. Mounds of rubbish.

angular gravel, separated by an irregular bed of sandy loam containing no flints. This gravel continues past Lee Farm to the river Arun, at Stopham; but on the left bank of the river not a flint is to be seen in the section at Stopham Bridge, where a distinctly bedded river-gravel occurs, containing only Lower Greensand and Wealden detritus. Thus, while the Rother has brought down an abundance of angular flints, the Arun, emerging from the Lower Greensand defile, has accumulated only such detritus as is furnished by the Lower Cretaceous and Wealden strata (see fig. 2).

Fig. 2.—Section at Stopham Bridge.

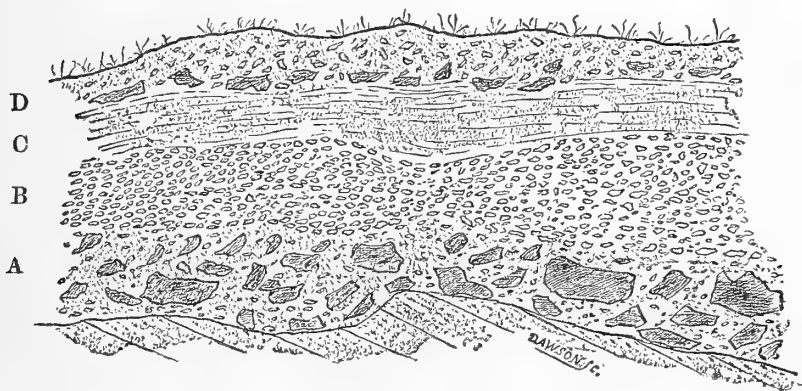

D. Angular fragments.
C. Loam, with no stones.
B. Pebbles (waterworn).
A. Pebbles, with large masses of ironstone.

Following the main stream down towards the chalk gorge at Houghton, a good coating of gravel is found on the isolated hill at Timberley, at a height of 57 feet above sea-level. In the railway-cutting here 5 feet of angular and subangular flint gravel is seen,

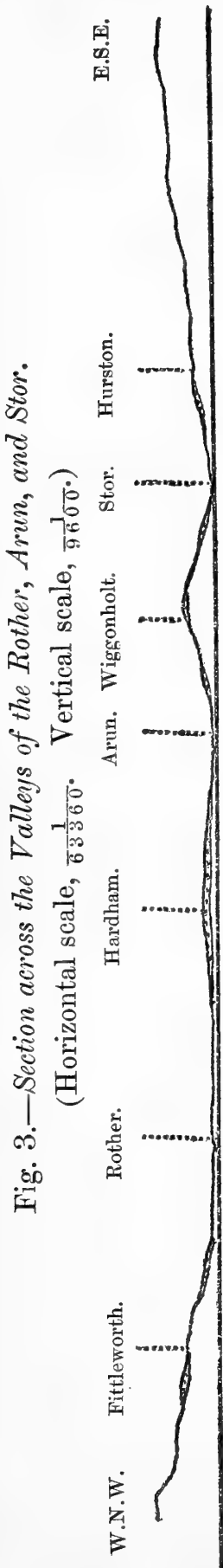

with occasionally a very marked stratification. A similar gravel capping is found on the isolated 50 feet contour to the west of Amberley, and again at Houghton, while, within the gorge, the gravels of North and South Stoke, and the mammaliferous gravel at Peppering, 80 feet above the present level of the Arun, have already been sufficiently noticed*.

At Greatham, on the left bank of the Arun, the gravels differ chiefly from those just described in containing very much less chert. Chert, in fact, as a prominent constituent of the gravel, is confined to the right bank of the river, which is in striking harmony with the difference in composition and texture of the Greensand beds lying to the west of the river, where a brittle and cherty stone succeeds to the compact argillaceous stone of Pulborough†.

Gravel extends all along the left bank of the Arun from Greatham through Rackham to Wiggonholt and Wickfield Bridge, where two small tributary streams, the Chilt and the Stor, join the main river. Near Wiggonholt Common, on the very edge of the alluvium of the Arun, some pits show the following section:—2 feet of white sand, with few or no flints, resting on a narrow band, 6 inches in width, of dark sand. Below this are 4 feet of sandy gravel, with small angular flints and large lumps of ironstone. On the summit of Wiggonholt Common, at a height of 132 feet above the river, the surface-deposit consists of a thin coating of angular flints, with a little ironstone, but no chert fragments. Traces of rude stratification are seen in this gravel in some of the sections, and the level is nearly the same as the highest gravel of Fittleworth Common, on the opposite side of the river.

The gravels of the Stor, near Hurston, are an instructive example of the denudation effected by this small stream (see fig. 3). On each side of the river beds of gravel occur, extending above the 50 feet contour. There can be no doubt that these are old river-gravels of the Stor. At Redford sections are seen showing about 5 feet of ferruginous sandy gravel with contorted stratification. In the lower parts flints are small and scarce, and the sand is finely

* Mantell, 'Geology of S.E. England,' p. 41.

† Martin, 'Geological Memoir on part of W. Sussex,' p. 67.

laminated. On Hurston Warren the same gravel is seen in frequent sections, covering the small plateau between the two streams to a height of 50 feet. These gravels contain angular and subangular flints and ironstone, but no chert. It is in these valley- and terrace-gravels that mammalian remains have been found in several localities, as at Burton Park, Fittleworth, Wiggonholt, and Peppering; and Murchison states that these remains only occur where the drift is protected from percolation by a capping of loam or clay.

But in addition to these gravels of undoubted river-origin, there are other deposits which do not appear directly connected with the present river-system. From Petersfield to West Heath, and thence to Rogate, Trotton, and Midhurst Commons, extensive beds of angular flint-drift, often mingled with ironstone fragments and chert, rise in places to 500 feet above sea-level and 300 feet above the present drainage-level. West of the Arun these beds of angular drift are most abundant between the Rother and the Chalk escarpment, but they do not usually occur either on the Upper Greensand or Gault. The higher grounds, also, near the summit of the Lower Greensand escarpment are quite free from flints. Murchison has described these beds so fully that nothing need be added here concerning them*. East of the Arun, however, upon or near the watershed between the Arun and Adur rivers, similar beds occur, and these will now be described in detail.

Near Storrington, on approaching the summit of the hill known as Sullington Common, angular flints become plentiful, and several small pits have been opened in a true gravel-deposit of variable thickness, and extending in patches as far as Clayton on the west and Wantley on the north. The deposit is thickest on the highest

Fig. 4.—Section on Sullington Common.

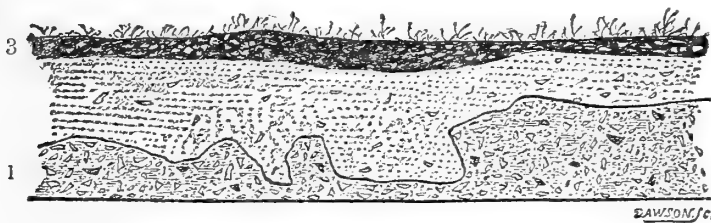

3. Black sand, with bleached flints.
2. Sand, with a few flints.
1. Angular gravel.

contours of the Lower Greensand, which reach the height of more than 200 feet in this district. A pit near the Washington road shows from 1 to 5 feet of sandy gravel, the upper part bleached, the lower part ferruginous. The flints vary from a diameter of four inches to the smallest fragments, some of which are so angular and fresh that their edges cut like a knife. Ironstone occurs sparingly, but chert is apparently absent; below the gravel is found sand, with a few flints here and there. Scarcely any traces of stratification can be

* Quart. Journ. Geol. Soc. vol. vii. p. 349.

detected in this section, and, after a long and careful search by Mr. P. R. Head and myself, no traces of any flint implements were discovered. In 1881 a pit was opened near the windmill, in which, as on Fittleworth Common and elsewhere, the deposit consists of two distinct parts, angular gravel and an irregular bed of sand containing few flints (see diagram, fig. 4). Obviously connected with this spread of gravel is another smaller patch on Kithurst Warren, at a height of 150 feet above sea-level. In a small pit in the fir plantation contorted stratification is visible, and the angular gravel overlies an irregular bed of sand containing only a few flints, and resting upon an eroded surface of Lower Greensand. The junction is well marked by a layer of ironstone and angular flints (see diagram, fig. 5). No flint implements have been detected in these beds,

Fig. 5.—Section at Cootham Firs.

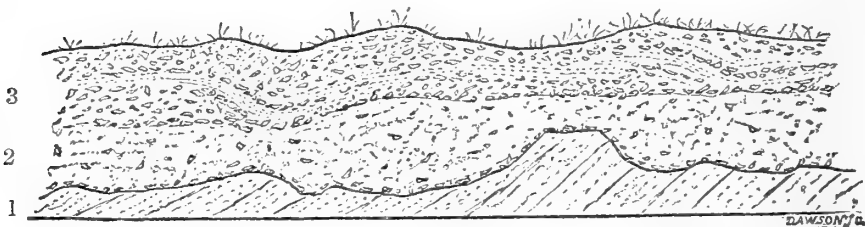

3. Angular gravel, with contorted stratification.
2. Sand, with a few angular flints.
1. Lower Greensand.

which continue at intervals still further westward, reaching in Parham Park an elevation of 200 feet. Although this last locality is within a mile of the alluvium of the Arun, it does not seem probable that these accumulations of flint-drift have any connexion with the lower river-gravels of Wiggonholt and Greatham, beyond furnishing some of the materials of which the latter are composed.

Going eastward from Sullington Common towards the watershed angular flints abound everywhere, and sections of thin gravel are plentiful above the 200 feet contour. This gravel rises to an altitude of 300 feet at Longbury Hill, where it is seen much mixed with large masses of ironstone. The best section in this patch of gravel is on the roadside at Gravel-pit Plantation, where 5 feet of ferruginous sandy gravel are exposed. Here there are very decided traces of stratification, often slightly contorted. Seams of clayey sand are intercalated with the gravel, and the base, consisting of sand with only a few flints, rests upon an eroded surface of Lower Greensand (fig. 6). This gravel lies exactly upon the watershed between the Arun and the Adur (see fig. 11, p. 656). Continuing along the road from Washington to Steyning the ground again rises above the 200 feet contour near Lower Chancton Farm, and here again there are small sections showing a thin coating of gravel of the same nature as that of Longbury Hill. This patch of flint-drift appears to extend past Buncton to Guess's Farm, but disappears on descending below the 100 feet level on the north. A striking feature of this

deposit is its extension in a thin band from Lower Chancton Farm past New Common copse to Lock's Farm, right at the base of Chanctonbury Hill, thus forming a remarkable exception to the

Fig. 6.—Section on Longbury Hill.

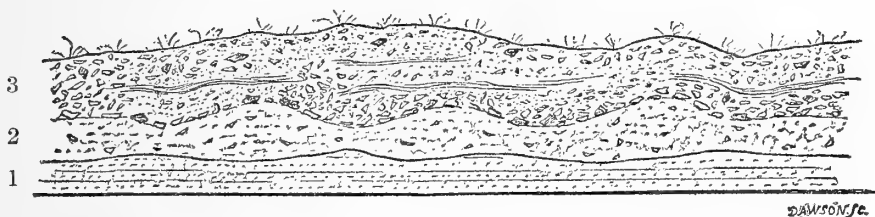

3. Angular gravel, with seams of clayey sand.
2. Sand, with a few angular flints.
1. Lower Greensand.

almost total absence of broken flints from the Gault and Upper Greensand of the rest of the Arun basin*.

The Adur Basin.—Leaving the watershed at Longbury Hill, the ground rises between Ashington and West Grinstead in a long ridge to a height of nearly 150 feet at Hooklands and 180 feet at Windcave's Farm. Thence there is a gradual fall to the level of the river at West Grinstead. The whole of this ridge, consisting of Weald-clay, is covered thickly with whole and broken flints, intermingled with a few small fragments of ironstone. The boundaries of this bed of drift are very clearly defined on the north-west by the small stream running past Benton's Place and New Barn, and on the south-east by a line running from Hook Farm to Clothall's Farm. This ridge is separated by a deep valley from the high ground at Ashurst, which reaches an elevation of 83 feet near Pepper's Farm. Here also a coating of angular flints is seen upon the surface of the Weald Clay and Lower Greensand, and several small sections occur, showing 1–2 feet of gravel. The flints are occasionally cemented into a dark ferruginous breccia. As at West Grinstead, the drift extends right down to the margin of the river. The banks also of the small stream running past Honey Bridge have a narrow fringe of gravel, extending in places up to the 50 feet contour. Following up the course of the Adur towards its source flints occur again to a slight extent near Shipley, but after passing Coolham their occurrence is extremely rare.

Undoubted river-gravels of the Adur occur at several places on the right bank of the river between Bineham Bridge and Bramber. At Heath Barn, near Horsebridge Common, they cover the 50 feet contour, but around Wickham Farm they reach the height of 95 feet. A thick coating of flints is seen again on the opposite side of the river at Streatham, but at no great height above the stream. Nearer Steyning the railway-cutting exposes about 3 feet of gravel at a

* This does not apply to the Gault near the banks of the Arun, which, at Wiggonholt, Hardham, and Timberley, is covered with river-gravel, as previously described.

height of 30 feet above the river, with angular and subangular flints and very imperfect traces of stratification; and again south of Steyning railway-station the 50 feet contour is covered with a similar deposit. These gravels contain chiefly flints, Wealden sandstone, and a little ironstone, and differ totally in composition from the gravels in a similar position with respect to the Arun valley.

Crossing to the eastern side of the Adur valley, a long narrow ridge of gravel and flinty loam is found extending from the river-side at Catsfold, past Henfield to Bilsborough and Blackstone Farms. The flints are thickest above the 50 feet contour, and small sections of gravel are to be seen at Henfield in the pond at Henfield Place, and also near Parsonage Farm. The highest points reached by this drift are 103 feet at Furner's Farm and 100 feet at Wantley Farm, thus nearly corresponding with the highest gravel on the opposite side of the river at Ashurst (see section, fig. 13, p. 656). The influence of drift loams on the stiff soil of the Weald-clay is well seen at Park Farm, where the fields on the southern bank of the stream have a light, friable soil, contrasting strongly with the bare Weald-clay on the northern bank. Smaller patches of flinty loam occur at Sibb's Farm and also at Chates, where it is strongest on the isolated 50 feet contour. The long ridge of detritus just mentioned borders and faces the stream running due west from Hurstpierpoint. To the south of a line drawn from Henfield to Blackstone between these points and the chalk escarpment scarcely a flint is to be met with, although a good deal of the ground lies above the 100 feet contour.

Going eastward from Blackstone the ground rises considerably, and between Albourne and Hurstpierpoint we approach the sources of the small tributary streams which drain into Cutler Brook from the south. These streams have cut small valleys into a plateau covered with angular flint drift. This is especially well seen at Albourne Place, where the flints are most numerous on the highest level, 136 feet above the sea; and again at Sandpit Cottage, Calves Wood, and thence to Danny Park and Hurstpierpoint, where sections of gravel may be seen above the 200 feet contour at Tott's Farm (see section, fig. 12, p. 656). Throughout the whole of this district the tops of the plateau are drift-covered and the valleys almost completely free. This spread of drift can be traced along New Lane to Stonecroft Copse and thence to Ockenden's Wood, intruding into the Upper Greensand almost to the very foot of the chalk escarpment. Around Clayton the drift is absent, but a small patch of flint-covered soil is again seen on the new road, near the Halfway-house, resting upon the Upper Greensand. These spreads of angular flints can scarcely be referred to the existing streams, since they occupy the highest contours, and are very near the main watershed.

From this plateau-drift, however, true river-gravel and flinty loam have been formed on the left bank of the stream which flows from Hassock's Gate to Danworth Farm and Hickstead. Near Hickstead Bridge the Weald-clay is covered with a thick deposit of angular flints, which are almost entirely absent on the right bank, thus proving their derivation from the higher grounds around Hurst-

pierpoint. All these gravels agree in containing both angular and subangular flints, very little ironstone, and no chert or Wealden sandstone.

We now come to the line of watershed between the Adur and the Ouse, the elevated ridge running through Ditchling to Burgess Hill. At the village of Keymer, half a mile from Ditchling, small traces of flint-drift are to be seen near the Post Office; but on ascending to the summit of the water-parting at Lodge Hill, 278 feet above sea-level, the fields are again strewn with an abundance of flints, which become thickest near Oldland Windmill. This bed of gravel is entirely confined to the summit of the watershed, and disappears abruptly on descending below the 200 feet contour in any direction. Following the line of watershed from Ditchling to Burgess Hill the surface is at first depressed, and there is no sign of any drift; but the moment we ascend the higher ground at Burgess Hill small sections of gravel, from 1 to 3 feet in thickness, again appear at about 200 feet elevation. The flints here are as angular as any observed elsewhere, and they rest upon the Weald-clay. On the hill at Inholmes Farm the clay has been extensively worked for bricks and pottery, and on closely examining the sections numerous pockets of gravel are seen, sometimes dipping from 2 to 3 feet into the clay and then again thinning out and perhaps entirely disappearing. The flints are very angular, no traces of stratification are here visible, and there is very little admixture of ironstone. The general appearance of these remnants of angular gravel is represented in the diagram (fig. 7). Again, at Oathill Farm the fields are thickly

Fig. 7.—Section at Inholmes Farm.

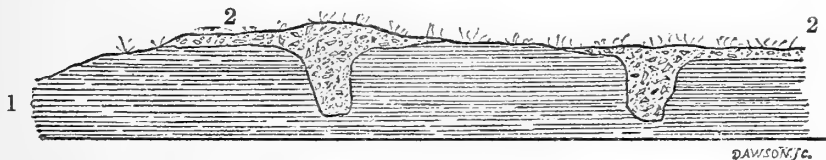

1. Weald clay.

2. Gravel.

strewn with angular flints to a height of 181 feet above the sea-level, or 80 feet above the level of the river. From this point the gravel descends to the river, and forms a well-marked bed along its left bank, the right bank at Wivelsfield and Lunceshill being quite free from any detritus, nor was any trace of this gravel found in the lower grounds lying to the west of the line of railway. An interesting feature of this gravel at Oathill is that it rests partly upon the Hastings beds, and, unlike the gravel at Amy's Mill, near Horsham, previously described, it consists almost entirely of angular flints, with only a very small admixture of Wealden fragments.

Crossing now the valley between Burgess Hill and Ditchling Common, the gravel reappears at the latter place on reaching an altitude of from 170 to 200 feet, and at Ditchling Potteries several sections are visible, showing from 1 to 5 feet of angular flint-gravel

resting upon Weald-clay. In some cases faint signs of stratification are visible, and there are intercalated seams of clay. Many of the larger stones have their axes horizontal, and, as at Inholmes Farm, the gravel penetrates eroded hollows in the Weald-clay beneath. The angular flints continue to occur in patches wherever the ground rises above the 200 feet contour, and thick coatings may be seen covering the fields near Middleton Common Farm, and again in parts of Blackbrook Wood; but the drift suddenly disappears on descending to the lower levels north of Plumpton Green.

Thus we see that the line of watershed from near the chalk escarpment at Ditchling to the very edge of the central dome of Hastings beds still retains, on its highest levels, isolated patches of angular gravel, in every respect resembling the watershed gravels previously described near Sullington and Heath Common; while along the margins of the Adur and its tributaries there occur, in several localities, true river-gravels at various heights above the present level of the water.

The Ouse Basin.—Descending from the watershed at Ditchling Common, a small belt of river-gravel may be traced along the course of the stream which flows from Blackbrook Farm past Plumpton Railway Station. This stream joins the Ouse at Barcombe Mill, near which gravels occur in several localities. One patch occupies the 50 feet contour at Crink Hill, and ascends at Barcombe Cross to an altitude of 100 feet above sea-level, or nearly 70 feet above the present level of the Ouse. This gravel contains flints, Wealden-sandstone and Lower-Greensand *débris*, and rests upon Weald-clay. It is separated by a small valley from another similar patch at Barcombe village, where it occurs at a height of 120 feet, near the windmill, while a third patch is seen at Banks Farm, on the north of the stream which runs from Plumpton. About a mile north of Cooksbridge the ground rises considerably, and near Folly Farm the 200 feet contour is reached. Here angular flints again become numerous; but it does not seem probable that these have any connexion with the present drainage-channels, since they occur at some distance from any existing stream, and are considerably higher than the gravels at Barcombe. In level they agree with the watershed gravels at Ditchling previously described, and they may possibly be the last remnants of a plateau-drift.

Continuing along the margin of the Ouse, gravel with many angular flints occurs again at North End, near Hamsey, where it attains an elevation of about 60 feet above the sea-level, and near Wellingham, on the opposite side of the river, other small patches occur at nearly the same altitude. These are about 50 feet above the level of the river, and are evidently old river-gravels of the Ouse. At about the same level we find gravel at Malling House, near Lewes, and again on the opposite bank of the river in a well-defined terrace between the 50 and 100 feet contours. A good section of this gravel is seen in the railway-cutting near St. John's Farm. The flints are very angular, but there are some Tertiary pebbles.

Although this is undoubtedly a terrace-gravel, scarcely any signs of stratification are visible in this section. South of Lewes gravel occurs on the summits of the two low hills, called respectively Upper and Lower Rise, at an elevation of nearly 50 feet above the level of the alluvium. Besides flints, some Tertiary and Wealden pebbles occur here. The whole of the slope bordering the alluvium between Kingston and Rodmell is covered with angular drift up to the 100 feet contour, making a well-defined terrace-gravel. At Rodmell windmill there is an interesting section of this gravel resting upon the Lower Chalk, into which it penetrates in deep pipes, 5 or 6 feet deep. The gravel here consists of angular and subangular flints, apparently less angular than the watershed-gravels, with a lot of small Wealden pebbles, disseminated through a clayey loam. The pipes have a well-defined coating of clay, with only a few flints, between the gravel and the chalk, a phenomenon which has previously been noticed in connexion with gravel-pipes in calcareous rocks*.

Crossing now to the eastern bank of the Ouse, from Beddingham to West Firle, and thence to the railway at Burgh Bridge, a good many flints are scattered over the surface in a thin band parallel to Glynde Reach, and occupying generally the 50 feet contour; but no sections were noticed showing any depth of gravel. Between West Firle and Selmeston also the fields usually have a plentiful coating of angular flints, especially near Ripe Crossing and Sherrington.

So far as the river-gravels are concerned, the Ouse north of Barcombe has very few patches of any importance, although small deposits occur at Isfield, Little Horsted, Buckham Hill, and Buxted Park, while loams and brickearth occur near Sheffield Bridge and Lindfield. On entering the Hastings-beds country flints no longer occur either on the surface or in the river-gravels.

The watershed between the Ouse and Cuckmere passes through Selmeston, and on approaching the higher ground near this place

Fig. 8.—Section at Selmeston Church.

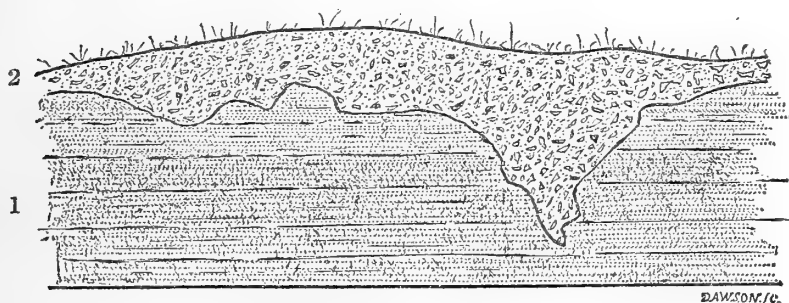

1. Lower Greensand.

2. Gravel.

flints become more abundant, until near Selmeston church a good section is seen showing 7 or 8 feet of angular gravel resting upon an eroded surface of Lower Greensand. The flints here are very

* Prestwich, *Quart. Journ. Geol. Soc.* vol. xi. p. 79; and Foster and Topley, "Superficial Geology of the Medway," *Quart. Journ. Geol. Soc.* vol. xxi. p. 455.

angular, and there is but little admixture of ironstone. No trace of stratification is to be noticed, and the gravel sometimes makes huge pockets in the Greensand below (see diagram, fig. 8). It is interesting to find this bed of gravel rigidly confined to the 100 feet contour, which extends from Selmeston to Berwick Station, where sections are again visible in the railway-cutting. On descending this ridge and ascending again to a similar level on the isolated hill at Mayo the flint-drift reappears, capping the hill, but not a trace is to be seen in the lower grounds to the north around Ripe and Laughton. Approaching the Cuckmere river there is only one locality in which the 100 feet contour is reached, and this on a small hill immediately overlooking the river, about half a mile south-west of Sessingham. The altitude here is 110 feet, or nearly 90 feet above the level of the river, and this hill is again capped with angular flint-gravel. This is so evidently an outlying patch of the gravel at Selmeston and Berwick Station that it is noticed here, although the locality is well within the Cuckmere basin. The Selmeston gravel extends southwards as far as Berwick church, overlapping the Gault and part of the Upper Greensand.

Thus in the Ouse basin we find an exact repetition of the phenomena observed in the basins of the Arun and Adur, viz., well-defined river-gravels bordering the streams at various altitudes, and traces on the watersheds of an old plateau-drift which furnished part of the materials for the gravels of the lower levels.

The Cuckmere Basin.—The gravels which have just been described as occupying heights of 100 feet or more above the sea-level at Berwick Station are intimately connected with other beds at a lower level, which seem to be of undoubted river-origin. The reason for the close proximity of these gravels is to be found in the narrowness of the Cuckmere valley and the small distance intervening between the river and its watershed. The lower gravel is to be seen on descending the hill at Berwick church, towards Lower Berwick. From this point it extends past Winton to Alfriston in a narrow band, fringing the river at between 25 and 30 feet above its present level. On the opposite side of the river, at Milton Court, it occurs again, and several patches of angular flints are to be found higher up the river, as at Highfield Bank and Milton Barn. Near Milton Crossing a good section of this lower gravel is to be seen in a cutting south of the railway, where 3 or 4 feet of loam and gravel, full of angular flints of all sizes, rest upon an uneven surface of Lower Greensand. There are here distinct traces of stratification, although the flints are very angular. This bed of gravel covers the 50 feet contour close to the river. Similar gravel occurs at the same elevation on the opposite side of the river, and again near Chilver Bridge, where the whole of the 50 feet level is thickly covered with angular flints.

Between this point and Michelham the banks of the river consist of low mounds of loam, with many very small Wealden fragments and a few flints; but at Michelham Priory there is a small bed of river-gravel, chiefly composed of waterworn Wealden pebbles

together with a few angular flints, but at no great elevation above the river.

Approaching the eastern watershed of the Cuckmere, traces of old flint-covered surfaces again become visible on the highest contours. Thus, in Abbot's Wood, near the Royal Oak public-house, indications of a thin coating of angular flints occur at an elevation of 134 feet above sea-level, and again at New House at a height of 136 feet. A striking example of the occurrence of this flint-drift on the highest levels only is to be seen in a field near Eastland Coppice, where the highest level in the neighbourhood is reached at an altitude of 152 feet. Here there is an abundance of angular flints, with some Tertiary pebbles; but no sections occur to show any depth of gravel. Although these gravels appear to be very thin and in fragmentary patches only, it is interesting to note even the smallest traces of flint-drift on the watershed of this the last and smallest of the rivers in the area under discussion.

Of the deposits of the Ashburn valley there is nothing to add to what has already been described by Sir R. Murchison* and Dr. Mantell†. The superficial deposits are chiefly loams, from which at Eastbourne many bones of fossil Mammalia have been obtained.

Subaerial Deposits.—Besides the above-mentioned accumulations of angular flint-drift, the surface of the Lower Greensand in many localities has a few feet of sandy or loamy deposit containing large angular fragments of ironstone and generally small angular flints sparingly disseminated throughout the mass. In the majority of cases where this deposit is present the surface of the rock below is greatly eroded, and ironstone is not present. From the constant manner in which these deposits confine themselves to the outcrop of the Sandgate beds, there can be little doubt that they are merely superficial accumulations.

Occasional flints, as well as Lower-Greensand ironstone, are scattered over the surface of the Weald-clay to the very margin of the central dome. Tertiary pebbles also are frequently to be met with. These doubtless represent the remains of the strata which formerly covered the Weald-clay area. Flints, however, are much less frequently met with on the Weald-clay of the Arun valley than in the case of the Adur and the Ouse.

Erratic Blocks.—Not a single instance has been noticed of the occurrence of foreign boulders upon the surface of the Wealden valley itself, but I procured a moderately large granite boulder from the summit of the Chalk escarpment. The boulder lay amongst a thick coating of flints on some ploughed land at Kithurst, close to the edge of the escarpment, and exactly upon the 600 feet contour of Kithurst Hill. The occurrence of this boulder is so remarkable that it merits a more detailed description. The mass weighed between 5 and 6 lbs., and had an irregular shape, with a rough surface destitute of any signs of scratching or polishing by ice-action. When broken it exhibits the structure of a moderately

* Quart. Journ. Geol. Soc. vol. vii. p. 355.

† 'Geology of S.E. England,' p. 43.

Fig. 9.—Map of the Southern Portion of the Wealden Area. (Scale $\frac{1}{8}$ inch to 1 mile.)

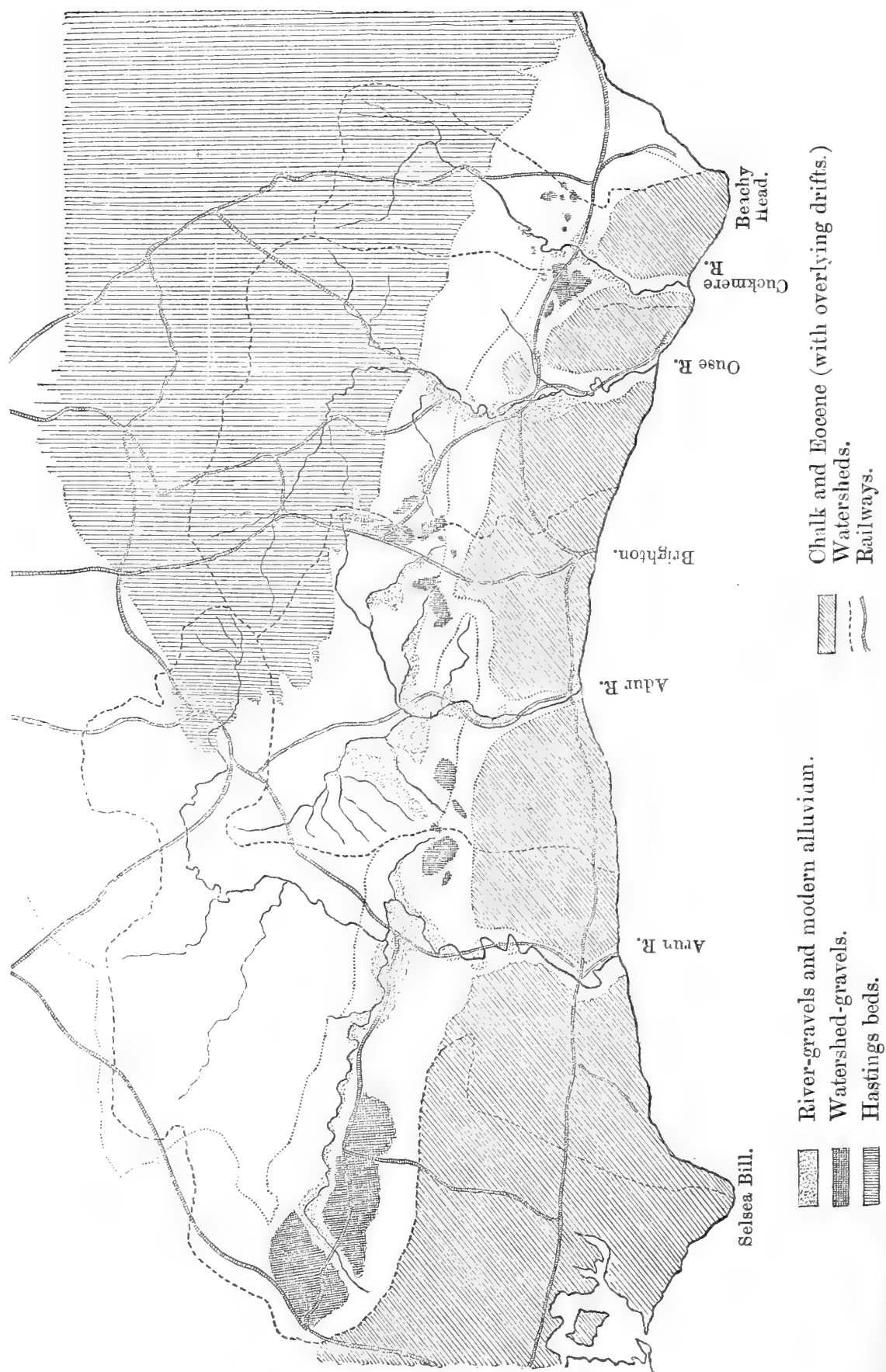

The fine dotted line marks the outcrop of the Lower Greensand.

coarse-grained granite, with an abundance of pink and white felspar, and small grains of quartz. Black mica is also present. Although the rock is much decomposed, I prepared a thin slice for microscopic examination. In this the felspar is seen to predominate largely and is almost wholly kaolinized, scarcely any of it retaining the depolarizing power. Iron stains are common along the edges and cleavage-planes of the crystals. The quartz is in irregular grains, and sometimes discoloured by decomposition-products: the grains are generally cloudy, owing to the presence of innumerable minute fluid- or gas-cavities. The mica is biotite, very dark and strongly dichroic. Hornblende does not appear to occur, but some opaque patches of magnetite are to be seen. The section bears a strong resemblance to a specimen of Peterhead granite in my cabinet.

Until the conveyance of this boulder to its position on the Chalk escarpment by natural transport is confirmed by the discovery of other blocks, it will be better not to venture upon any theory as to its origin, especially as the presence of erratics in such a position would necessitate a modification of accepted views respecting the physical condition of the south of England during the Glacial epoch.

General Conclusions.—Although it is clear in many cases that the gravels just described bear a close relation to the present drainage-channels, and old river-beds are easily to be recognized at various elevations above the present water-level, yet there are many difficulties to be encountered when it is endeavoured to explain the origin of the beds of angular drift which lie either upon the main watersheds or upon the higher contours far removed from existing rivers. Sir R. Murchison maintained that all the beds of angular drift within the Wealden area, irrespective alike of their position with regard to the river-valleys, their composition, or the evident traces of stratification which many of them reveal, are “the results of an agency of vast intensity,” of a former powerful but transient current, which “denuded the surface of the bare rocks in many parts, and at the same time distributed broken materials along a zone of limited width,” especially where the higher ridges arrested the progress of the current*. In support of this theory he dwells particularly upon the want of stratification in the drifts of this area, and also upon the fact that in the more eastern portions the stones are more waterworn, and finally give place to beds of loam without any admixture of flints. Mr. Martin supported this view with the statement that the Weald valley looks like a great water-channel after a flood—some parts being clean denuded, others loaded with drift †. Prof. Prestwich in 1851 agreed with Murchison in advocating the sudden, tumultuous and rapid accumulation of the angular drift, and Mr. Hopkins, in 1852, expressed similar views ‡.

* *Quart. Journ. Geol. Soc.* vol. vii. p. 349.

† ‘*Geol. Mem. of Part of W. Sussex*,’ p. 84; and ‘*Phil. Mag.*’ ser. 4, vol. vii. p. 116.

‡ *Quart. Journ. Geol. Soc.* vol. viii. p. xliv.

A general review of the evidence in favour of this view has been so recently given by Mr. Howorth* that it only remains here to examine how far the theory of a sudden flood will explain the facts described in this paper.

In the first place, it becomes evident to anyone who carefully examines these beds of drift that, instead of having been formed after the present configuration of the land had been established, and having been arrested here and there from some rapid current, all the evidence points to an interruption in the continuity of the beds by the subsequent lowering of the valleys by denudation. The accompanying sections, drawn across the river-valleys, point to the existence of an ancient drift-covered plateau lying between the base of the Chalk escarpment and the margin of the central dome (see figs. 10–12). Denudation has destroyed almost every trace of this old plateau, except on the higher grounds, near the watersheds, and even here the remnants of the drift are thin and fragmentary, and are cut through by the smallest depressions. This is especially noticeable around Hurstpierpoint, Ditchling, Burgess Hill, and Berwick. In fact wherever the smallest trace of the plateau-drift has been preserved it is invariably confined to the highest contours, and ends abruptly on passing a certain level. From this ancient plateau the flint-drift trails out in the direction of the streams, forming lower terrace-gravels of more recent origin.

Murchison's statement that the gravels become more waterworn in the eastern portions of this area was not borne out by my observations, the gravels at Selmeston and Berwick being quite as angular as any of the more western drifts. Moreover, the theory of a strong current setting out from the west is scarcely in harmony with the local character of the drifts of different areas. Thus at Hardham, on the right bank of the Arun (fig. 3), the gravels contain an abundance of ironstone and chert from the Lower Greensand, and these substances occur *in situ* at no great distance from the river. But on the left bank of the same river chert is much less plentiful, and becomes quite rare in the gravels of the upper parts of the eastern tributaries, which do not flow through districts in which chert is a constituent of the rocks. Ironstone also, which is abundant in the gravels of the Arun and Adur, becomes quite scarce in the valleys of the Ouse and Cuckmere, where the Lower Greensand is lower and thinner and only occasionally contains bands of ironstone.

This same connexion between the materials composing the gravels and the composition of the underlying strata may also be noticed in the watershed gravels. Thus the drift at Petersfield is stated by Murchison to consist only of flints: further eastwards it becomes mixed with chert and ironstone; but at Longbury Hill, between the Arun and Adur basins, scarcely any chert is to be found, although an abundance of ironstone occurs both in the gravel and in the underlying strata. At Ditchling and Burgess Hill even the ironstone is far less common, and at Berwick it becomes quite insignificant. The Arun gravels, again, contain no considerable quantity of

* Geol. Mag., Nov. 1882, p. 509.

flints until after receiving the Rother and the Stour, two tributaries which rise near the Chalk escarpment. The Adur, in both its western and eastern branches, has flint-gravels only where its tributaries rise in the flint-covered surfaces near its watersheds.

Any tumultuous easterly current would certainly have mixed up the detritus to a sufficient extent to have obliterated any such evidences of a purely local origin. The theory, therefore, of a torrential current, while certainly not required for the explanation of the lower gravels, is inadequate to account for the origin of even the watershed-drifts.

Let us now endeavour to compare the drift-phenomena of Sussex with those of neighbouring districts. When we turn to the northern watershed of the Wealden area, we find there, as Mr. Topley has long ago pointed out, extensive deposits of gravel, nearly all of which can be referred to the action of existing rivers when they flowed at a higher level. But in two separate localities gravel deposits occur, the origin of which is not so clearly established. One of these is at Limpsfield, at the western end of the Darent valley, where a coarse angular gravel occurs *on the watershed*, 500 feet above sea-level. The other is at Warren House, *near the eastern watershed of the Stour*, where gravel containing Tertiary pebbles caps a hill 300 feet above the sea. Of these two patches of gravel Mr. Topley remarks that, under any theory, they are difficult to account for, and their origin must for the present be left undecided*. We see therefore that there is a general agreement in the drift-deposits of the northern and southern portions of the Weald. In both cases we find river-gravels, and also gravels on the watersheds, of which the origin cannot be traced to any existing streams.

If, now, we extend our observations beyond the Wealden area, we find, in Hampshire and the Isle of Wight, gravel-deposits which Mr. Codrington considers to be of far greater age than the valley-gravels of the rivers †. These gravels reach an elevation of 420 feet in the New Forest and 390 feet on Headon Hill. Now no one can avoid being struck by the close resemblance between the Headon-Hill gravels and those of the Wealden area of West Sussex. Mr. Topley has already suggested a possible connexion between the angular gravels of Midhurst and Rogate Commons and the higher portion of the great Hampshire sheet of gravel in its easterly extension. Mr. Prestwich, again, in describing the Quaternary phenomena in the Isle of Portland and around Weymouth, says:—“Capping the high chalk ranges of Upton, the White Nore, and Abbotsbury, is a thick bed of perfectly angular sharp chalk-flints in a reddish clay reposing on a deeply-indented surface of chalk, while a similar angular drift composed of fragments and masses of chert and ragstone caps the Upper-Greensand hills north of Abbotsbury. . . . I merely refer to them as having been the storehouses whence much of the latter drift-beds have been supplied” ‡. Devon and Cornwall

* Topley, ‘Geology of the Weald,’ p. 297.

† Quart. Journ. Geol. Soc. vol. xxxvi. p. 549.

‡ *Ibid.* vol. xxxi. p. 41.

also show abundant traces of plateau-gravels, at heights varying from 300 to 1200 feet above sea-level. The materials of these gravels are mostly of local origin, and, while the slopes of the hills are free from drift, the valleys have abundant gravel-deposits up to 100 feet above sea-level*.

Now when we look for an explanation of these phenomena, which are seen to be general over the whole of Southern England, it is evident that we must accept one of two views. Either the higher plateau-gravels are the oldest, and the lower valley-gravels represent former river-beds, and are consequently a measure of the denudation which has been effected since their deposition; or all these patches of gravel have been deposited since the excavation of the valleys, their sporadic character being due either to a kind of selective deposition, or to a subsequent process of selective denudation. The former theory has been sufficiently proved by Mr. Topley to hold good for the gravels of the northern portion of the Wealden area, and the phenomena described in this paper respecting the southern portion tend to a similar conclusion.

The chief advocate of the marine theory is Mr. Searles V. Wood, who, in an elaborate contribution to this subject as late as 1882 †, discredits the view that there has been any considerable excavation of the Wealden valleys since the deposition of these gravels, which, he states, were accumulated either under the sea, or in estuaries as the sea was invading or retiring from the land.

An examination, however, of the facts described in the earlier portion of this paper shows the extreme difficulty of accounting for the gravels of the southern portion in this manner. Whether we examine the valley of the Rother at Fittleworth, the Arun at Henfield, Wickham, and Steyning, or the Ouse between Barcombe and Rodmell, the *terrace-gravels always slope gently towards the rivers, and terminate abruptly in the opposite direction*. Could any process of selective deposition or selective denudation by the sea explain this fact? Again, let us consider the plateau-gravel of the Adur watershed at Ditchling. Here we find three or four isolated hills, close together, each capped with gravel, and in each case the intervening valleys are free from drift. Is it not more in accordance with the fundamental principles of geology to see in this fact the excavation of the valleys subsequently to the accumulation of the drift, than to imagine some unintelligible process of selective deposition on the summits of these hills, when submerged beneath the sea, or a peculiar process of denudation, which during emergence swept the valleys clear and left each hill-top covered with drift? An exactly similar but still more striking instance of the same kind is seen in the Cuckmere valley, where we find isolated hill-tops capped with drift, even when an area of only a few square yards reaches above the particular contour to which the gravels are confined.

Another argument against the view that the Wealden valleys

* Belt, Quart. Journ. Geol. Soc. vol. xxxii. p. 83.

† Quart. Journ. Geol. Soc. vol. xxxviii. p. 690.

have not been considerably lowered since the Glacial period is to be found in the existence of Crag deposits at Lenham, on the edge of the Chalk escarpment, which points to the conclusion that the whole Wealden valley has been excavated since the Pliocene period*.

When we come to consider the origin of the plateau-drift, we are met by considerable difficulty. The flints are the residue of the Upper Chalk which still covered a certain portion of this area after marine denudation had exposed the Hastings beds of the central dome, and probably also the higher portions of the Lower Greensand escarpment. Similar flints, many of them angular and broken, still lie in great quantities upon the summit of the Chalk escarpment, and in many places, as at Beachy Head, build up a considerable thickness of angular, ferruginous gravel, not unlike the drift-gravels just described. The broken and shivered condition of the flints of the Wealden area has been attributed by Mr. S. V. Wood to the result of alternating frozen and warmer conditions of the surface of a soil which remained permanently frozen below †.

But to account for the distribution of the beds of angular gravel on the higher grounds, and the evident traces of stratification which they in many cases present, appears to require something more than a mere letting down of the angular flints, in proportion as the Chalk disappeared, upon an eroded surface of the inferior strata; for if such a process has been going on during the recession of the Chalk escarpment, it should also be going on now, and flints should occur, along the base of the escarpment, upon the Upper Greensand and Gault. Yet it is just here that the flint-drift is absent, except in certain instances near the watersheds, as near Chanctonbury and Clayton. An examination, moreover, of the diagrams of the watershed gravels is sufficient to show that such phenomena as contorted stratification, intercalated beds of sand or clay, and alternations of fine and coarse materials require some more powerful agent than mere subaerial deposition, however angular and confused the general character of the drift may be.

It seems necessary therefore to look upon the watershed gravels of Heath Common, Ditchling, and Berwick as the remains of an eastern extension of the angular drift of Rogate and other parts of West Sussex, and as a true subaqueous deposit.

SUMMARY.

It will be convenient, in conclusion, to sum up the results which it has been the object of the present paper to prove, viz. :—

1. That the highest and oldest gravels of this area occur only in patches in or near the watersheds: that, although apparently without fossils, these gravels exhibit some traces of subaqueous origin, and may possibly be contemporaneous with similar deposits occurring throughout the southern counties of England.

* Prestwich, Quart. Journ. Geol. Soc. vol. xiv. p. 322; C. Reid, 'Nature,' vol. xxxiv. p. 342.

† Geol. Mag. 1882, pp. 339, 441.

2. That the valley-gravels have been mainly built up of the detritus from the older beds : that these valley-gravels have been formed by existing rivers, flowing in their present directions, and that in the lower gravels mammalian remains have been discovered in several localities.
3. That the gravels of this area are strictly local in character, and contain only such detritus as can be derived from the districts drained by the different rivers or their tributaries.
4. That a considerable amount of denudation is proved, not only by the fragmentary nature of the watershed-gravels, but also by the height to which the terrace-gravels reach above the present level of the rivers.
5. That the finding of a granite boulder on the summit of the Chalk escarpment may, if confirmed by other similar discoveries, considerably modify existing ideas respecting the physical condition of this area during the Glacial period.

Fig. 10.—General Section across the River-Valleys. (Horizontal scale, $\frac{1}{253440}$. Vertical scale, $\frac{1}{9800}$.)

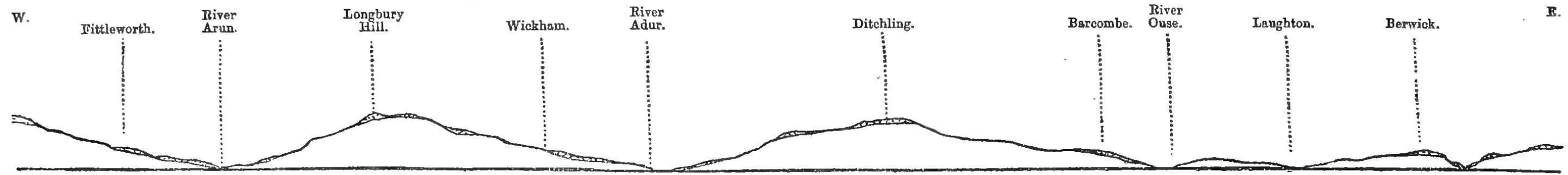

Fig. 11.—Section across the Arun and Adur Watershed. (Horizontal scale, $\frac{1}{84480}$. Vertical scale, $\frac{1}{9800}$.)

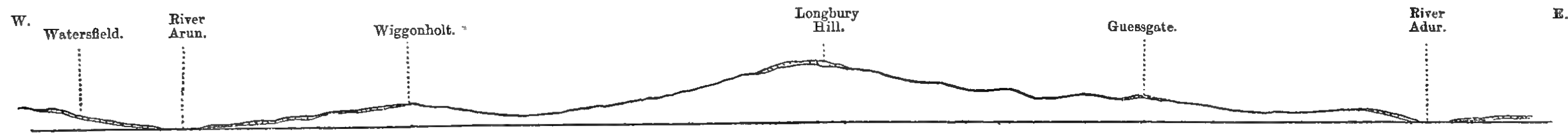

Fig. 12.—Section across the Adur and Ouse Watershed. (Horizontal scale, $\frac{1}{84480}$. Vertical scale, $\frac{1}{9800}$.)

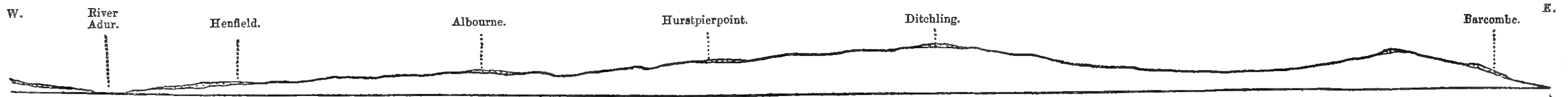
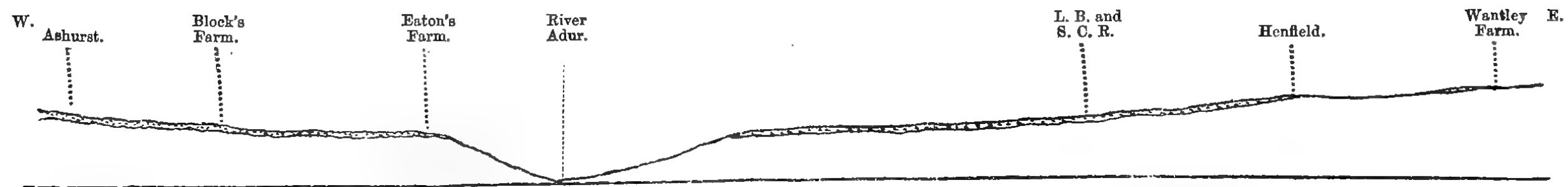
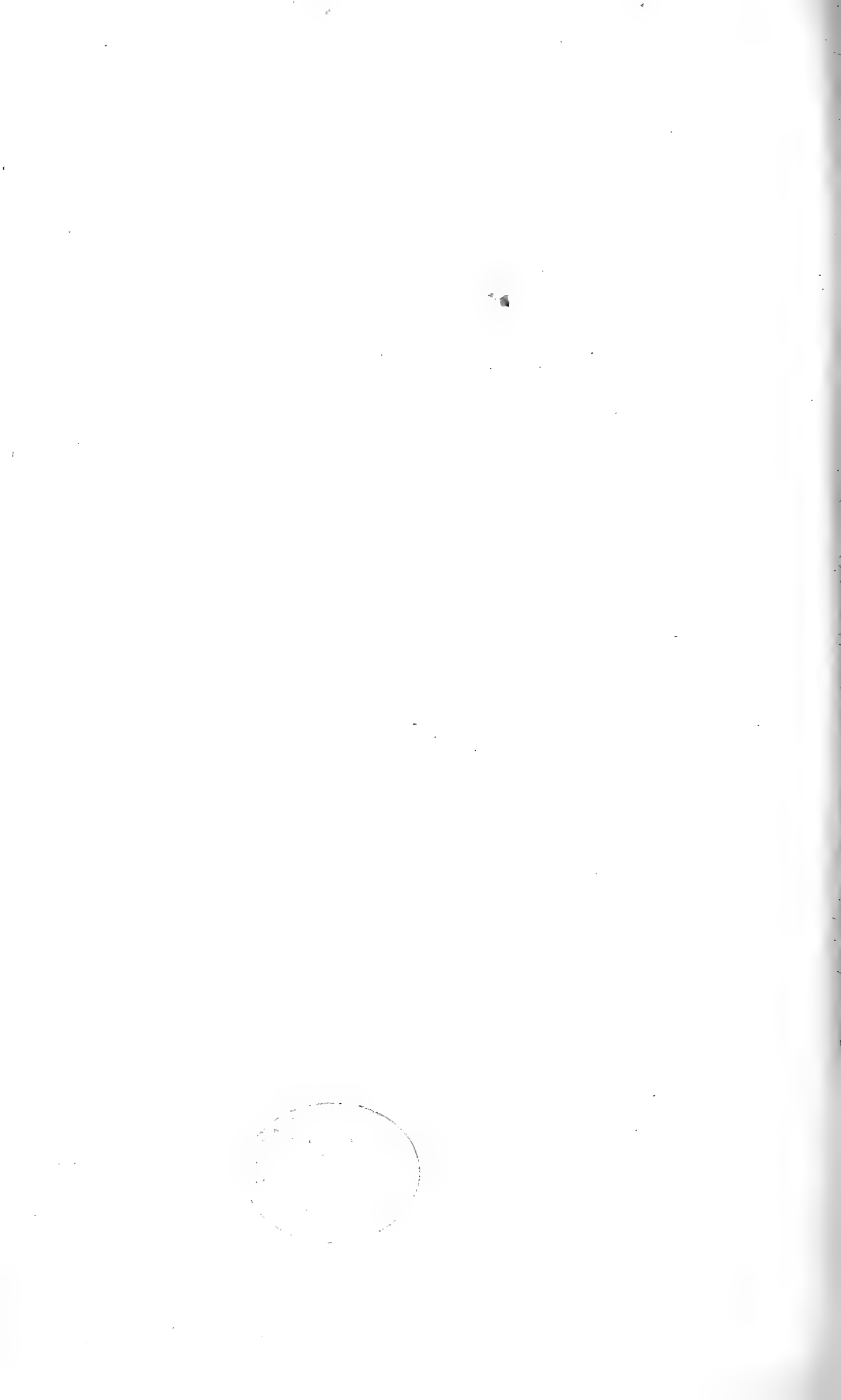

Fig. 13.—Section from Ashurst to Henfield, across the Adur Valley. (Horizontal scale, $\frac{1}{21120}$. Vertical scale, $\frac{1}{2400}$.)





45. *On the ANCIENT BEACH and BOULDERS near BRAUNTON and CROYDE, in N. DEVON.* By T. M'KENNY HUGHES, M.A., Woodwardian Professor, Cambridge. (Read June 23, 1887.)

THE ancient high-level beaches of the south-west of England have long attracted notice. Paris * referred some of them to blown sand; Carne † and Boase ‡ mentioned the occurrence of similar phenomena around the coast of Cornwall. Godwin-Austen § described a "raised beach" at Hope's Nose, and later on, in his paper on the superficial accumulations of the coasts of the English Channel ||, gave an account of several other deposits in different localities, which seemed to him to indicate an elevation of the coast-line. The position of many of these beaches is indicated by Greenough on his geological map and by De la Beche on the maps of the Geological Survey.

Among the raised beaches we generally find included the sand-cliffs of Saunton Down and Middle Borough, on the coast west of Barnstaple. These deposits have a further interest attached to them from the occurrence at their base of large boulders of various kinds of rock, some of which, it would seem, do not exactly resemble any rock-masses in the drainage-areas from which they could have been transported to where they are now found by any kind of river-action.

Sedgwick ¶, Murchison **, Williams ††, and De la Beche ‡‡ have described these cliffs, pointing out the similarity of the deposits to those of the modern shore, and, assuming that the whole was an ancient beach, of course explained its present position by changes in the relative level of land and sea. It seems to have been generally spoken of as a Raised Beach from the time of these earlier observers till the year 1866, when Mr. Spence Bate §§, from a careful examination of the sections, returning to the views of Paris, arrived at the conclusion "that the entire structure conduces to the conviction that the so-called raised beach is in reality the undestroyed remnant of an extensive district of wind-borne sand similar to that which now exists on Braunton Burrows."

In a paper published in 1867 ||| Mr. Pengelly replies to Mr. Spence Bate, and gives exact measurements taken at various points along the cliffs. He is led by a consideration of the low level at which various land-plants are found to infer that the tide does not now often reach the level to which the remains of *Balanus* indicate that

* Trans. R. Geol. Soc. Cornwall. vol. i. 1818, p. 4.

† *Ibid.* vol. iv. 1832, p. 259.

‡ *Tom. cit.* pp. 259, 270-273, 320.

§ Proc. Geol. Soc. vol. ii. 1834, p. 102.

|| Quart. Journ. Geol. Soc. vol. vii. 1851, p. 118.

¶ Trans. Geol. Soc. vol. v. p. 279; Proc. Geol. Soc. vol. ii. p. 442.

** *Ibid.*

†† Trans. Geol. Soc. vol. v. p. 287; Proc. Geol. Soc. vol. ii. p. 441.

‡‡ Report on the Geol. of Cornwall, Devon, and W. Somerset, 1839, p. 425.

§§ Trans. Devon Assoc. Adv. Sci. Lit. and Art, 1866, p. 128.

||| *Ibid.* 1867, p. 415.

it once commonly rose. He thinks that the "transportation" of the great boulder of red granite "required more than wave-power merely," and, on the assumption that it was carried on ice, points out that it would necessitate a considerable change of level to float such a large mass of ice to where the boulder now lies. Incidentally he notices the vertical shafts in the sand-cliffs, and suggests in explanation that the process begins by the infiltration of rain-water containing carbonic acid in solution, which dissolves the calcareous cement of the consolidated sand, and "that in periods of continued drought the water evaporates, the winds disperse much of the dry loose sand, but communicate a rotary motion to the residue, and thus produce the cylindrical or subcylindrical form of the shafts, and that by a repetition of this process the shaft is gradually deepened until it passes completely through the sand-beds."

The points to which I invite attention in the following paper are :—

- (1) Is this deposit on the southern slopes of Saunton Down a raised beach? and
- (2) Were the above-mentioned boulders carried to their present position by ice?

I would avoid any future misapprehension of my meaning by defining what I understand by a raised beach.

A raised beach is a portion of the shore-deposits which were accumulated when the land was at a lower level. It is not sufficient to show that the deposit could not now be laid down by the sea in the position and at the height at which it is found, unless it can be shown also that no other conditions than a sinking of the land would explain its occurrence in such a position or at such a height.

High-water mark for the purposes of this inquiry does not mean the level to which the tide rises in calm, but the much higher line up to which wind-driven Atlantic waves in spring-tides carry sand, shells, and blocks of stone. The tidal range in Barnstaple Bay is stated by Mr. Hall to be between 38 and 40 feet; but enormous masses of rock may be seen thrown up to much higher levels in almost any little cove around this coast.

We know that stones &c. can be caught in the waves* and hurled to the top of vertical walls of rock; but this does not give a beach-like deposit. If, however, we have a long slope on an open shore, or still more in a narrowing creek or bay, and ocean waves breaking on it, beach-deposits (stones, sand, shells, &c.) are carried far above what is commonly understood by high-water mark. Alter the coast-line, destroy a promontory or sandbank, turn on a current, or change the outfall of a river and the sand and shingle are swept away; the sea cuts into the solid rock, and leaves a cliff with the thin end of the long shore slope seen on top of it, now many feet above high-water mark †.

That is not a raised beach, for it would require no change of

* Hughes, Journ. Vict. Inst. or Phil. Soc. Gt. Brit., Feb. 1887, p. 4.

† Cf. Carne, Trans. R. Geol. Soc. Cornwall, vol. iii. 1828, p. 229 *et seq.*

level to produce it. It would be brought about by the uniform waste of an irregular coast-line, where the destruction of headlands and the shifting of sandbanks and currents determine which part of the rocky coast shall have a protecting mantle of sand for a time thrown over it, and which shall be stripped to bear the ceaseless lash of the waves.

Referring to the diagram (fig. 1), let L, M represent high- and

Fig. 1.—*Diagram Section showing the Mode of Formation of some of the High-level Beaches of Devonshire.*

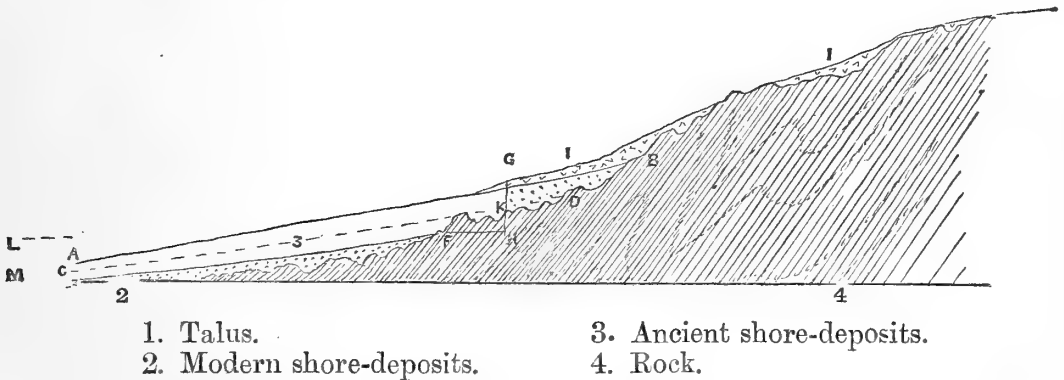

low-water mark, the level of ordinary high and low water respectively, and E F the surface of the existing sand-slope; then the waves in storm may break against the foot of the cliff G H, but never get as high as K, the base of what is called a raised beach.

But when A B or C D was the surface of the sand-slope, the sea in storm, especially if it was in a bay or creek or corner, would rush up the incline along A B or C D to a level far above K. Then when the gradual changes of the coast, shifting the sandbanks, eating away the promontory, and so on, had removed the sand marked (3) and cut back the cliff to G H, the portion above K would look like a raised beach, and, in fact, would be practically out of reach of the waves.

If any change of level has taken place in this case it seems to me to be quite as likely to have been a downward as an upward movement. At any rate it is probable that if the sea were thrown more strongly on to the sand-dunes in Barnstaple Bay by a small depression, the tendency would be to drive them back to the east, leaving just such patches of consolidated sand and talus in cliffs near Saunton Court as are now seen along the cliff further west. And the height to which the, properly speaking, marine deposits occur is so little above ordinary high tide that there is plenty of margin left for storm-waves to carry them up to where they are now found.

When a long sweep of shore such as Woolacombe sands or Bideford Bay leaves a wide expanse of sand exposed between every tide to the sun and wind, it is curious to notice how soon after the sea has left it the surface of the sand begins to move under the influence of a dry wind. One might almost think sometimes that the sun and wind dried one grain at a time and started it off immedi-

ately, so damp is the sand, while the yellow haze a few inches deep tells us the surface is beginning to drift away. Stick a slate or a shell up to catch it, and you soon find how rapidly the work is going on. So the sandhills are formed which protect the lower part of the lowlands behind from the rush of the wind-driven tides. In exceptionally high tides, however, the sea is carried far up the incline formed by the dunes, and so marine deposits are intercalated in the lower part of the blown sand. Thus we must have in all such cases marine deposits at the base, then resting on them alternations of Æolian and marine, all heaped up on solid rock or estuarine silt or whatever the floor may happen to have been.

When we examine the upper part of the deposit, we find that the sand is carried by the wind above the highest water-mark to form the dunes, and in like manner up the hill-sides that bound the estuary or bay.

Here another operation is at the same time going on. The talus due to gravitation or pluvial action creeps down over the shifting sand and covers or is covered by it. This may go on up to any level if the slope be favourable and the supply of sand sufficient; and if

Fig. 2.—*Diagram showing Succession of Deposits West of Saunton Court.*

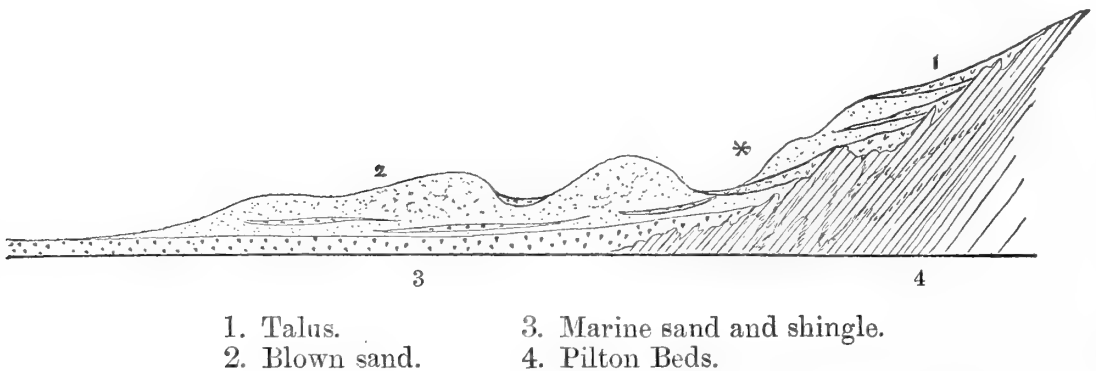

- | | |
|----------------|-----------------------------|
| 1. Talus. | 3. Marine sand and shingle. |
| 2. Blown sand. | 4. Pilton Beds. |

deposits thus formed are cut back and exposed in section, we see alternations of blown sand and talus, but further from the hill the blown sand only, as shown in the diagram (fig. 2).

Where therefore only this last-described deposit of blown sand and talus rises above highest water-mark, but the marine deposits at the base are no higher than could now be reached by the waves, there is no evidence of change of level such as would justify our calling the deposit a *raised beach*.

Along the coast from the north end of Braunton Burrows around Croyde Bay, but especially under the south slope of Saunton Down and west of Middle Borough, there is an almost continuous beach, which I would refer to the agencies I have just been describing (see fig. 3). The upper part consists of angular fragments of the rocks which occur on the hill immediately above it imbedded in earth, the result of the subaerial decomposition of those rocks. Where the cliff has been cut back pretty close to the steeper slopes the thick-

ness of this deposit is very great. Conspicuous white bands are sometimes seen along the face of the section, but this is only a superficial efflorescence of salt due to the evaporated spray from the sea.

Below this talus there is a deposit of sand of very variable thickness, often having at various horizons in the upper part bands of angular talus like that above.

The bedding is very clear in the weathered cliff (see fig. 4). It is often false-bedded, and in sections at right angles to the coast is

Fig. 3.—Diagram Section across so-called Raised Beach under Saunton Down, North end of Barnstaple Bay. (Scale 200 feet to 1 inch.)

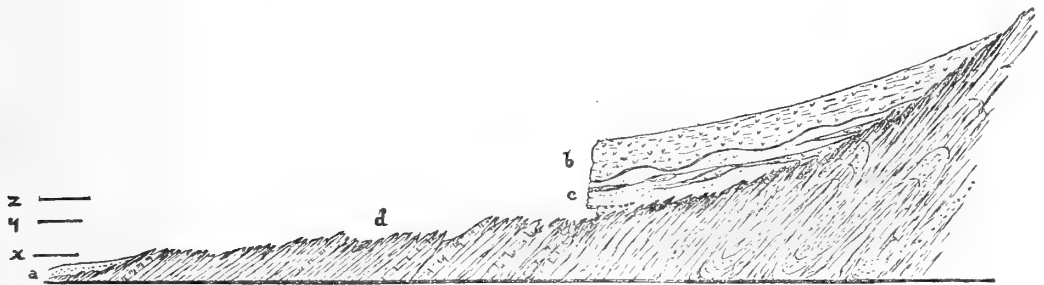

- a. Recent sand and shingle.
- b. Talus, overlapping and dovetailing with upper part of c.
- c. Blown sand, with subaerial talus intercalated in upper part, and sea-beach deposits alternating with lower part.
- d. Pilton Beds.

x. Low water. y. High water. z. Spring-tides and storms.

Fig. 4.—Cliff of Consolidated Sand resting on Cleaved Rock (Pilton Beds), Saunton Down, North Devon.

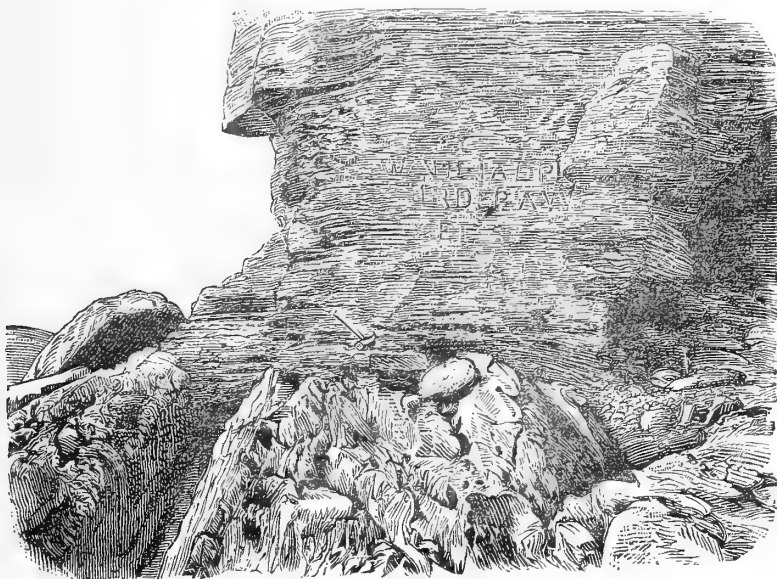

sometimes seen to slope up rapidly against the hillside, as indicated in the section (fig. 3).

-Land-shells occur here and there, singly or in bands, *Helix vir-*

gata being the most common, as on the adjoining sand-dunes. Sea-shells are rare, and only such as might have been carried by birds or rolled up the sand-slope by the wind.

In the lower part of the sand-cliff, however, sea-shells are common, and there are lines of shore shingle which generally forms an irregular conglomerate at the base. It is consolidated into a hard calcareous sandstone, so hard that it is used in the neighbourhood for rough walling. Owing to its being but little jointed, it long resists the battering of the waves, which have to remove it almost grain by grain. Here and there, however, great masses are lifted out and trundled by the waves along the shore, furnishing an example of the sea quarrying out and moving along the shore, at the same level as the boulders of granite, masses as large as, if not larger than, those for the transport of which ice-agency is invoked. One such, resting on the cleaved rocks at the foot of the cliff, is shown on the left-hand side of fig. 4.

The consolidation of the blown sand round the coast of Devon and Cornwall was noticed and explained by Paris *, who ascertained by experiment that the shelly sand contained from 60 to 64 per cent. of carbonate of lime. Boase † describes the same thing, and quotes an old author who, fifty years before his time, explained the induration of the sand by infiltration of water charged with carbonate of lime, only he described it as sparry or coralline juice, such as forms incrustations in the bottoms of culinary vessels and in water-pipes. In a little ravine about half a mile west of Middle Borough I noticed a section as of a transverse gully about twenty feet deep, at the base of which, under some seventeen feet of talus, was three feet of sand, in which were bands about an inch thick of a dark sandy ironstone. This also seemed to be quite a recent formation.

Where the sand from above has run down through a crevice, like sand in an hour-glass, it has often eaten out a cylindrical hole from two to four feet across. I am inclined to think from what I have seen that, except where there has been a hole quite through, these chimneys are never formed, but that some of them are originally half-cylinders, that is to say, the sand pouring over the edge of a sand-cliff cuts a groove out as would water. I think it certain that when once formed the wind helps to carry on the work and round them off, but that the action of the wind on the top of the sand could never form them by producing a rotatory motion, as the water of an eddying mountain-torrent bores holes in the solid rock by whirling pebbles round in any hollow that arrests them.

Flints occur in this ancient beach as on the modern shore, and there has been much speculation as to their origin and mode of transport. An examination of the flints themselves will, I think,

* Paris, "Geological Structure of Cornwall," Trans. R. Geol. Soc. Cornwall, vol. i. 1818, p. 194.

† Boase, "On the Submersion of part of the Mount's Bay," &c., Trans. R. Geol. Soc. Cornwall, vol. ii. 1822, p. 143. See also Carne, "On the Mineral Productions of St. Just," *ibid.* p. 333.

be sufficient to justify our dismissing several of the hypotheses suggested.

They are not flints of the kind used by primæval man for the manufacture of implements.

Their numbers, wide distribution, and constant association with ancient deposits at very various levels make the hypothesis that they were accidentally introduced quite untenable. They go back to times far earlier than any ships that carried ballast.

They are irregularly iron-stained, subangular gravel-stones, not flints derived directly from the chalk.

They are of the same kind as those common in the high-level marine deposits of Wales* and the north of England, and occur all round our western coasts.

They are found on the St.-David's plateau. They have been brought to me by Mr. F. J. H. Jenkinson from the gravels that occur here and there all over the Scilly Isles. They are handed on to lower levels by every later denudation, and are generally to be picked up in every modern shingle. They form part of the great gravel banks of unknown age that lie off our south-west coast.

They do not appear in the older boulder-clays of Wales, but came in with the shore-drifting that mixed up the débris of the northern ice-sheets with that from the Cambrian mountains, and dates from the Moel-Tryfan and St.-Asaph stage of the Pleistocene.

It is perfectly clear that the upper part of this cliff below the talus consists of nothing but blown sand. We have only to walk south as far as Braunton Burrows to see a similar deposit now in process of formation. The sand is blown up against preexisting dunes, so as to show in section steeply inclined beds, just as it does where blown against the hill-sides of Saunton Down or Middle Borough. A few stones are carried here and there far up the sand-slope and in between the dunes. Shells are transported some distance up by the waves, and still further by the wind. Certain species are carried in by gulls and crows. I saw here among the sand-dunes the shells of *Patella vulgata*, *Pecten varius*, *Mytilus edulis*, *Macra stultorum*, *Scrobicularia piperata*. On the coast of Pembrokeshire I have seen the shell of *Nassa reticulata* rolling up a steep sand-dune in a gale of wind. The shells of land-mollusca, such as *Helix virgata*, *H. aspera*, *H. nemoralis*, *Bulimus acutus*, &c., are also blown about and rest in any sheltered hollow, or even in a footprint; but they do not occur indiscriminately throughout the mass, so that it often happens that over large tracts not a single specimen can be seen.

At the north end of the dunes the sand creeps up the hillside, extending in irregular hummocks as far at any rate as Saunton Court. If any change of current were to destroy the great barrier of blown sand, so that the sea rolled in below Saunton Court, and the sand next the hill were hardened a little by percolating water, we should have cliffs precisely similar to those now seen along the south side of Saunton Down and round by Middle Borough almost

* Quart. Journ. Geol. Soc. vol. xliii. 1887, p. 83.

to Baggy Point. The lower part only would be washed by the waves, and the upper part would appear to be beyond the reach of any tide, and not in the way of any possible accumulation of blown sand. But when the dunes were further forward they must have abutted, as now, against the hill at their north end, and the sand was blown up its flank as it is now near Saunton Court.

Along the sandy roadway down to the shore from Saunton Court the wind often strips off part of the sand and shows that the talus sometimes creeps down over the dunes and sometimes is covered by the blown sand. So there are alternations of stony earth, sand, shells, &c. in the upper part, just as we see in the ancient cliff further west.

It is easy enough to explain the slight difference in the character of the sand in the old sand-cliff and in the more modern dunes. The newer sand consists more largely of comminuted shell, whereas the acidulated water percolating from the hill-side has destroyed some of the shell in the sand abutting against it and has thrown the carbonate of lime down again where it has been exposed to evaporation.

That this process has been going on is shown by the casts of shells found in the solidified sand; and that the precipitation has taken place elsewhere is shown by the bands of calcite a quarter or half an inch thick which have formed along some of the more open divisional planes, by the crystals of calespar which line some of the cavities where shells have been, and by the solidified masses of sand described above.

So, I take it, this cliff of sand and angular stony débris on the shore south of Saunton Down and west of Middle Borough is no raised beach, but only the run-of-the-hill or talus overlapping and dovetailing into the top of the sand which was driven by the wind up the hillside when the sandy shore-line of Barnstaple Bay stood a little further west, and that the lower part of it, where the blown sand contains beds of shingle and marine shells, is only the part where the waves occasionally rushed over the base of the sand-dunes, and does not extend above the height now washed by the sea. To put it shortly, what is above sea-level is not beach, and what is beach is still within reach of the sea.

Resting apparently on the bare rock under this sandy deposit there are many large boulders, most of them composed of the gritty beds in the Devonian. There are, however, now visible three other boulders, the original source of which is not so easy to determine with certainty.

The first occurs about $\frac{1}{4}$ mile west of Middle Borough. It is a great mass of yellowish-white gneissose granite, the part exposed measuring some $8 \times 6 \times 6$ feet. The surface is somewhat decomposed and exfoliates in places. The boulder is capped by some of the talus, not, it appeared to me, the original mass of which the cliff was composed, but only a portion slipped from it.

The second boulder (fig. 5) occurs about halfway along the shore south of Saunton Down. It rises out of a little pool between the

jagged ridges of the rock just in front of a small alcove or cave in the western face of a portion of the sandstone cliff which runs out south from the hill. It measures about 4 feet across from corner

Fig. 5.—*Boulder of Grey Porphyry at base of Cliff South of Saunton Down, North end of Barnstaple Bay (April 11, 1887). (Scale $7\frac{1}{2}$ feet to 1 inch.)*

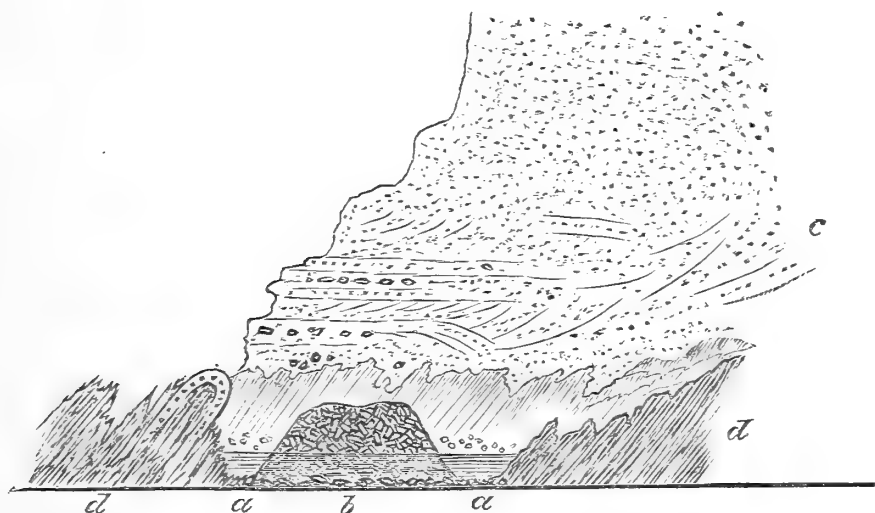

- a. Recent shingle. d. Pilton Beds.
 b. Boulder of grey porphyry in 1 foot of water.
 c. Consolidated blown sand, modified at base by action of sea, with lines of shingle and sea-shells, and alternating in upper part with talus.

to corner of the irregular rhomboidal mass now exposed. On the south side of it a fold over of one of the harder beds has caused a stronger barrier than usual and probably determined the position in which it rested.

This boulder consists of a grey porphyry much resembling that so common on Arenig; but I should be sorry to say that it could not have come from the felsite which occurs at intervals for many miles at the base of the Pickwell-Down Sandstone, as that is exposed only here and there, and, where seen, is so variable that we may easily allow that there may be parts of it very like the Saunton boulder.

The third boulder (fig. 6) is more like the Ross-of-Mull granite than any other with which I am acquainted. It occurs in a cave eaten out by the waves in the very base of the sand-cliff, a short distance further east than that last described. It rises out of some newly tossed-up shingle, and supports the roof of the cave. From the levels observed outside, it is clear that it must rest on the solid rock. It is partly concealed by the shingle, so that exact measurements cannot be obtained. From what was exposed when Mr. Townshend Hall saw it he estimated that it must weigh between 10 and 12 tons.

Mr. Townshend Hall* thinks "it is very doubtful whether there

* See note † on p. 666.

is any vein of a similar colour and texture on Lundy Island, capable of producing a block of such magnitude. The nearest point of the Dartmoor Granite is exactly 30 miles from Saunton, but any of a

Fig. 6.—*Boulder of Red Granite in base of Ancient Beach South of Saunton Down, North end of Barnstaple Bay (April 11, 1887). (Scale $7\frac{1}{2}$ feet to 1 inch.)*

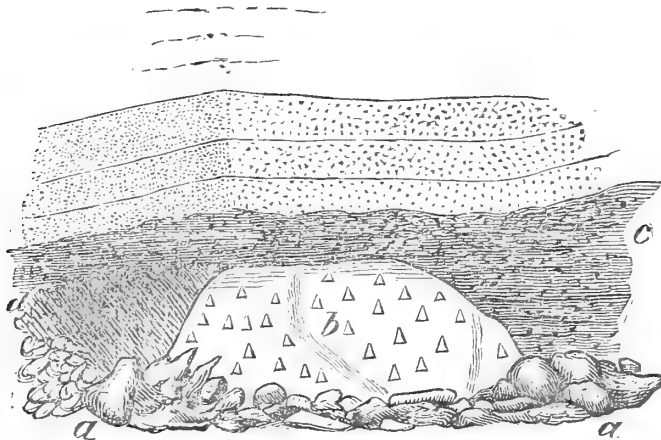

- a.* Recent shingle. *d.* Pilton Beds.
b. Boulder of red granite.
c. Consolidated blown sand, modified at base by action of sea.

red colour can only be obtained in very few localities, and at a much longer distance.”

The Rev. Dr. Williams* was of opinion that it could not have come from Dartmoor or Cornwall, or Lundy, but that it resembled much of the granite of the Grampians.

The boulders all occur in caves or at the base of deposits now being washed by the sea; in fact they would not be seen at all if they were not within reach of the breakers which are undermining the cliffs and exposing the original surface of the solid rock and the boulders which rest upon it, so that it is clear that they may have been tossed into their present position by the waves of the sea at its present level. The size of the boulders, and the height to which they have been thrown, is nothing for that western sea in storm; all round the coast we find plenty of larger blocks carried higher.

The character and mode of occurrence of these boulders does fairly raise the question whether there are any satisfactory traces of glaciation south of the Bristol Channel.

Mr. Townshend Hall † remarks on this subject:—“The great ice-sheets which in the Glacial Period covered the northern part of England and Wales, are not generally supposed to have extended

* Trans. Geol. Soc. vol. v. p. 287; Proc. Geol. Soc. vol. ii. p. 441.

† “A Sketch of the Geology of Devonshire by Townshend M. Hall,” White’s History, Gazetteer and Directory of the County (Devon), Sheffield, 1878, p. 16. See also Ussher, “Physical Features of Devonshire,” Trans. Devon. Assoc. Sci. Lit. & Art, vol. xii. 1880.

south of the Bristol Channel, and the characteristic furrows and scratches made by the friction of glaciers against the sides of valleys, so commonly met with in the north of England and Wales, have not yet been positively identified in Devonshire." But he very fairly points out that "if such markings ever were formed, they may have been rapidly effaced, owing to the soft nature of the slate, and the tendency of granite to become disintegrated on the surface." He is of opinion "that in various parts of both Dartmoor and Exmoor there are collections of stones and débris similar in every respect to those composing the moraines of modern glaciers, and valleys which have evidently been shaped by glacial agency."

Mr. Ussher * is of opinion that there are traces of glacial action in Devonshire, and accepts the view that the high-level beach of Saunton Down and Croyde and other places on the coast of Devon and Cornwall show evidence of elevation, but refers them to an age which corresponds to the "Interglacial Period" of the north and east of England, but in Devonshire was not succeeded by any later glaciation.

We must clearly distinguish between (*a*) a theory which refers these deposits to local glaciers originating within the area, as it is most improbable that any traces of such small local glaciation could remain, and (*b*) any hypothesis which refers boulders or clays to the terminal deposits, whether on sea or land, of the great ice mass, which we do know got down as far as the Bristol Channel.

Mr. Doe † has recorded some boulders of felsite occurring at a height of some 500 feet above the sea near Great Torrington, but these are described as resembling some of the Elvans.

Mr. Hall ‡ further mentions that "At Waddeton Court, near Dartmouth, a group of New Red Sandstone boulders are found reposing on the slate at elevations varying from 18 to nearly 200 feet above the level of the sea. At Harberton, near Totnes, also on a slate subsoil, boulders of a fine-grained trap occur at a height of about 100 feet, and are especially noticeable as being in some cases marked with parallel grooves or scratches. Another group, also composed of trap, is situated at Druid, near Ashburton; and boulders of various sizes have been recorded as occurring in the parish of Bishop's Teignton, near Teignmouth, some 300 feet above the sea." "Another instance of transported boulders occurs in the parish of Fremington, near Barnstaple, where boulders of trap are frequently found on or near the surface of a thick bed of brown clay much used for pottery."

Dr. Slade King also informs me that a waterworn boulder of coarse grey granite, weighing, say, 2 cwt., was found in a clayey deposit in draining a meadow on Bicklescombe farm, near Ilfracombe, some forty years ago. It was round and smooth, and had no grooves or striæ on it. Near it were found also, in the words of a

* "On the Chronological value of the Pleistocene Deposits of Devon," Quart. Journ. Geol. Soc. vol. xxxiv. 1878, p. 449.

† Rept. Committee on Erratic Blocks, Rept. Brit. Assoc. 1876, p. 110.

‡ *Op. cit.*

man who saw them, "some old stone things, hammer-heads and heads of spears, and such like." So it is probable that this boulder was in disturbed ground.

Setting aside, then, any suggestion of ice-action arising out of the character and position of these boulders, there does not appear to be any satisfactory evidence of glacial conditions in Devonshire. Its deep combs tell of long continuous erosion by the streams which have cut their way *back* from the coast almost horizontally into the tableland, not vertically *down* from the tableland to sea-level. After the rapids or waterfalls where the work is going on have receded, the talus gathers in every hollow and on every ledge, and the enormous thickness of the rainwash and run-of-the-hill in Devonshire tells of long-continued subaerial waste. The thin laminæ due to cleavage or bedding, or both, are all, so far as I have seen, turned over down the slope by gravitation, and none curve over in unexpected directions as if pushed by ice. There is nothing in the form of the ground or the character of the superficial deposits (saving always the boulders in question) to suggest ice-action.

The thick deposits of subaerial talus do not differ in character from those now being formed, and represent, not so much the greater intensity of the cold at some former period, as the greater length of time during which the surface has been exposed to the disintegrating effects of weather, just like what prevails there still.

The brown clays and other similar deposits referred to by Mr. Hooker as possibly of glacial origin are obviously not to be referred to the *direct* action of ice. They are not, as they stand, Boulder-clays or true glacial deposits; and if they are only due to the destruction of old Boulder-clays, we are opening up another question, viz. How far off were the Boulder-clays from which they were derived, and to what denudation can those brown clays be referred? Did it follow immediately upon the deposition of the moraine or when? It may be that Devon was under the sea during the age of extreme glaciation in N.W. Europe, and received some of the marginal glacial deposits and emerged early, so that all traces have been destroyed.

No one can tell how far back we must place the beginning of the subaerial denudation of this district. Nor have we evidence to show what was the condition of the surface of the great Devon plateau when first it emerged from the sea. That no blocks from what were then granite islands should have been anywhere left upon the sea-bottom around them is improbable; that no block from the central tors should have travelled down the ordinary channels of denudation in later times is also contrary to our usual experience in such cases. Therefore we have no right to assume the existence of glacial conditions to explain the occurrence here and there of a block of granite or other rock of *Devonshire origin* over the area surrounding those rocks in place.

If the red granite cannot have been derived from Dartmoor, where there are some beds of that colour, or beds which would probably in similar circumstances become of that deeper colour on

the outside—if the felsite cannot be a harder, more solid fragment of the Bittadon vein—and, further, if they cannot have been derived from known or inferred submarine bosses of rock *, which some believe furnished many of the boulders dredged up on the south coast of Devon and Cornwall; if the great boulder of red granite on the shore below Saunton Down must be identified with some Scotch rock, and if the block of dark grey felsite should be referred to one of the Arenig porphyries—that is on the hypothesis that these are north-country boulders—must we assume *local* glacial action to account for their occurrence where we now find them? and if not, what explanation can we offer of their being found in that district at all?

That they owe their present position on the jagged rocks of the coast and under the ancient beach to the action of the waves of a sea at about the same level as at present seems almost certain, because there they lie half buried in the shingle recently thrown up by the sea, and blocks as large are hurled by the waves to much higher levels in many of the creeks and coves around the coast †; but where did the waves pick them up?

A glance at the map will show that the district in question is just in the line of advance of the great tongue of ice that crept along the west coast of Scotland and the Lake District, and abutting against the ice-clad coast of North Wales, was held back by it, so that it was forced to turn round by Chester on the east and Anglesey on the west. Part of its terminal moraine ought to be found in the Irish Sea—at any rate, bergs from it must have floated off into the Irish Sea; and there is nothing improbable in the idea that many a half-melted mass stranded off the coast of Devon and left boulders strewn over the sea-bottom around. That the boulders were not dropped during a period of submergence where now found is shown by our never finding any masses of drift, but only isolated blocks, and they all look sea-worn. Nor were they carried ashore on bergs, because they are close up to a wall of solid rock where a berg could not have floated them.

Of course we must not attach any great weight to the fact that they have no glacial markings, as we only see them at all because the waves have washed away the surrounding sand and shingle, and that might have obliterated the striæ; but I think that any one who examines the blocks will allow that it is improbable that such is the explanation of the absence of all traces of ice-action. However, I will not lay much stress on this point.

Mr. Townshend Hall records some boulders with grooves, though they do not seem to have commended themselves to him as undoubtedly of glacial origin. If these were striated blocks, they still

* *Smeaton*, 'A Narrative of the Building and a Description of the Construction of the Eddystone Lighthouse with Stone,' 1813.

Godwin-Austen, *Quart. Journ. Geol. Soc.* vol. xi. 1855, p. 532; *ibid.* vol. xii. 1856, p. 38.

Prideaux, *Trans. Plymouth Inst.* 1860, p. 40.

Pengelly, *Trans. Devon. Assoc. &c.* vol. ix. 1877, p. 182.

† See *Carne*, *Trans. R. Geol. Soc. Cornwall*, vol. iii. 1828, p. 222 *et seq.*

might have been thrown up by the sea under existing conditions of level, &c. Many boulders may be seen along the coast of North Wales and Anglesey, washed out of drift and knocked about along the coast for a considerable distance before they have the traces of ice-grooving entirely rubbed out.

On the whole, then, I would thus sum up the evidence:—

The ancient beach of Saunton Down and Croyde is not a *raised beach*. The top is subaerial talus, the middle part blown sand, the base only marine; and the marine part is not above the reach of the waves of the sea at its present level.

The boulders of granite and felsite which occur at the base of the ancient beach were transported to their present position by the waves of the sea. Such as are of local origin could have reached the sea by the ordinary process of denudation; such as are possibly of northern origin could have been carried down the Irish Channel on bergs and been thrown up by the sea to where they would lie at any period subsequent to their being transported south by ice, but they do not in themselves imply any *local* glaciation.

46. NOTES on the FORMATION of COAL-SEAMS, as suggested by evidence collected chiefly in the LEICESTERSHIRE and SOUTH DERBYSHIRE COAL-FIELDS. By W. S. GRESLEY, Esq., F.G.S. (Read June 23, 1887.)

[Abridged.]

My principal object in this paper is to bring forward evidence in opposition to the view now generally accepted that coal-seams were formed from vegetation which grew on the spot.

It seems to me that the *growth-in-situ* theory has been, or is still, held by the majority of those who have considered or written upon the question to be the right one, partly because the accumulation of the vegetable matter of coal-beds by driftage appears to be totally beyond our comprehension, and partly (probably chiefly) because we have been told and led to believe that the underclays of coal-seams contain the *Stigmaria* which were the very roots of the trees the remains of which constitute the bulk of the coal.

During an extensive experience in the midland district in connexion not only with coal-mining, but also with the working of the underbeds, the fireclays, both underground and in opencast workings, I have had unusual opportunities of studying the relationship of the coal-seams to the underbeds, their fossil contents, &c.

The various points for consideration may be taken as under:—

- a. The relation of the fireclays to the coal-seams.
- b. Mode of occurrence of *Stigmaria* in underbeds.
- c. Erect fossil tree-stems with attached roots.
- d. Lamination of coal-beds.
- e. The presence of boulders &c. in the underclays.
- f. The foreign bodies in coal-beds.
- g. Marine fossils associated with coal-seams, brine, &c.

a. It must not be concluded, because almost every coal-seam rests upon a stratum partaking more or less of the nature of a fire-clay and enclosing *Stigmaria* and other root-like fossils, that such beds do not occur in other positions in the coal-measures; for the fact is that they very frequently occur lying immediately on the top of a coal-seam, sometimes wholly removed from coal; or they may occur as very thin layers, often very irregular and locally distributed, entirely enveloped in the coal. The thickness of an underclay bears no proportion whatever to that of the coal-seam resting upon it. The thickest coal-beds often rest upon the thinnest clays, and the greatest development of fireclay will be followed by the most meagre of coal-seams. I have also found it to be almost invariably the case that where underclays come in contact with coal-seams there is a sharp dividing line, a true bedding-plane, between the two; we do not find the clay gradually changing upwards into coal, but the change from one to the other is most distinct, in fact the plane of stratification is often quite a smooth one. Precisely the same characteristic obtains in the case of laminæ of clay running through the body of a coal-seam, *i. e.* where coal and clay are interstratified.

b. My experience is, that a considerable proportion of the underbeds do not contain *Stigmaria*-roots at all; but that they seldom fail to reveal the presence of thin grass-like fossil markings, I admit.

Very frequently the bed next below the underbed is crowded with *Stigmaria*, though not more so towards the upper than in the lower part. In *Stigmaria*-beds next but one below a coal-seam I have noticed several examples of that fossil standing erect, in a manner showing them to have been in all probability independent organisms. But when *Stigmaria* occur in the underclays the result of my investigations shows that they do not pass upwards into the coal. Only once or twice have I detected anything like such fossil roots running from the coal into the clay below *, and therefore my conclusion is that instances of this phenomenon are exceedingly rare. On referring to the writings of Binney, Brown, Dawson, De la Beche, Green, Hawkshaw, Lesquereux, Logan, Lyell, Macfarlane, Nicholson, Williamson, and others, I have failed to discover in them one single description of an actual *bonâ fide* erect fossil tree with its Stigmarian roots attached to it *and imbedded in the underclay*, whilst the stem entered or passed through the overlying coal-seam. Now, surely if coalbeds have been formed from trees and other plants whose roots grew in or penetrated the underclays or so called "old soils," unmistakable indications of their former existence ought to be present in great abundance; these roots must also have been more thickly matted together the nearer they approached the coal; and instead of there being, as there is, a most distinct break between the base of a coal-seam and the underbed, we should expect to find the one gradually changing into the other, as is so frequently exemplified in the junction of a peat-bed with the clay below it, where the roots can be clearly seen communicating with the vegetable mass above. Had instances of *Stigmaria* actually trending from the coal into the underbed been met with, we should undoubtedly have been long since furnished with exact particulars, locality &c., of such discoveries †. *Stigmaria ficoides*, then, so far as my investigations have gone, does not occur in the underclays as the fossil roots of trees, but rather, it would seem, as plants *sui generis*.

c. It would seem that the very significant fact of erect fossil tree-stems with *Stigmaria*-roots attached *in situ* being of so exceedingly rare occurrence just where they ought to be most common, namely, immediately below the bottom of a coal-seam, must obviously upset the theory which has been based upon the inference that because coal is probably largely made up of the remains of forest trees whose roots

* At the fireclay mines of Messrs. Ensor & Co., on Ashby Wolds; also at Aldridge Colliery, Walsall, where I am informed that *Stigmaria* penetrated a coal-seam and extended into the floor below. The roots in this instance proceeded from an erect fossil stem standing upon a 3-foot bed of coal.—W. S. G.

† Moreover, even supposing for a moment that the roots of the coal-forest trees, &c., did really grow in the underbeds, by what possible subsequent process can all the carbon have become concentrated at one exact level, namely, where the clay ceases and the coal-seam begins? Not a single example of a fossil tree (so far as I know) has ever been met with in which the roots were composed of clay or shale, and the stump of coal.

are the *Stigmaria*, it is almost proof positive that these trees grew on the spot, because we find the same kind of fossils in the underclays. When erect fossil stems or stools of trees are met with, they are generally either resting upon or at no great distance above the *tops* of coal-beds, though the largest and most perfect examples of such fossils have occurred in beds far removed from coal*. The absence of them in the underclays is conclusive evidence that they very seldom if ever grew there; and the fact of their very rare occurrence in the coal itself further strengthens the argument against a *growth-in-situ* formation of coal, at all events from *trees*. And when we find, as we do, impressions of the bark of large trees upon the base of a coal-seam next to the underclay, it is clear that the vegetable matter was transported from a distance.

d. Does a vertical section of a coal-seam afford any clue to the way in which it was accumulated? It seems to me that when we find that the structure, from top to bottom, is strictly a laminated one, that every layer, division, "bench," or what not, and every line or film observable in the "grain" of coal lies parallel to the plane of the seam, there is not a tittle of evidence that the coal-forming plants grew on the spot. Take a sample of coal from whatever locality you will, and from any part of any coal-seam, and its characteristic grain or laminae will be seen if carefully looked for. I have never yet in all my experience detected or heard of more than one or two upright forms of fossil stems (?) in coal; and I maintain that if trees grew in large quantities where the coal-beds now are, their erect remains would have materially interfered with the parallelism of the coal as existing. That pre-existing interruptions in this universal lamination can have since been obliterated by pressure or by metamorphism seems highly improbable. The *growth-in-situ* difficulty would also seem to be increased when we bear in mind that, spreading over very large areas of some of our coal-fields (measured by square miles in extent), there are conspicuous and comparatively thick layers of spore-coal, consisting almost wholly of macrospores, every one of which lies horizontally. Where, it must be asked, are the remains of the stumps of the trees from whose branches these myriads of seeds or seed-cases were shed? A satisfactory explanation of the cause or origin of the perfect lamination of coal, and of the phenomena of "partings" or distinct bedding-planes by which so many seams of coal are divided and subdivided, and of the insinuation of thin layers of clay into the seams, has yet to be given.

e. Occurring occasionally in some of the underclays in Leicestershire and South Derbyshire are well-worn boulders and pebbles of quartzite and quartz which have been transported from a distance †.

But besides boulders and the fossil *Stigmaria*, the fireclays sometimes contain fragments of the stems of tree-ferns, leaves, and other plants of a peculiar nature; *Anthracosia* also have been noticed

* I refer particularly to the "fossil trees" recently found at Clayton and at Bradford, Yorks.—W. S. G.

† In the underbed of the Coalburg seam in West Virginia, U.S.A., rounded quartz-boulders have been found.

associated with *Stigmaria* between two coal-seams*. And thus it would appear that the underclays were probably not the old *land-surfaces* which supported the coal-forests, but were true aqueous deposits.

f. Actually imbedded in coal itself have been found numerous quartzite boulders very similar to those found in the underclays, and these have turned up in many parts of England as well as on the continent. Other foreign bodies in coal-seams consist of the remains of aquatic mollusca, fish, &c. †.

g. That marine conditions prevailed, if not *during* the accumulation of many of our coal-beds, certainly *immediately afterwards*, is clear from the abundance in the roof-shales of the seams of fossils which must have had a salt-water habitat, and also from the fact that brine is so frequently met with in the pores of the coal itself ‡.

In conclusion, then, my contention is, that, notwithstanding all that has been written on the coal-question, up to the present time no facts have been brought forward which can in any way show that the plants forming coal-seams actually grew *in situ*, but that what evidence we do possess decidedly favours a drift- or, at all events, an aqueous origin.

* At Coleorton Colliery, near Ashby de la Zouch, the author found this shell between the "Lount Middle" and the "Lount Nether" coal-seams.

† From the "Main," the "Cannel," and other seams of the Leicestershire coal-field.

‡ The "Main" coal-seam of Moira, in the Leicestershire coal-field.

47. FURTHER OBSERVATIONS *upon* HYPERODAPEDON GORDONI.

By Prof. T. H. HUXLEY, F.R.S., F.G.S. (Read May 11, 1887.)

[PLATES XXVI. & XXVII.]

IT is now twenty-nine years since, in describing those remains of *Stagonolepis Robertsoni* from the Elgin Sandstones which enabled me to determine the reptilian nature and the crocodilian affinities of that supposed fish, I indicated the occurrence in the same beds of a Lacertilian reptile, to which I gave the name of *Hyperodapedon Gordoni*. I laid stress upon the "marked affinity with certain Triassic reptiles" (e. g. *Rhynchosaurus*) of *Hyperodapedon*, and I said that these, "when taken together with the resemblance of *Stagonolepis* to Mesozoic Crocodilia," led me "to require the strongest stratigraphical proof before admitting the Palæozoic age of the beds in which it occurs" *.

Many Fellows of the Society will remember the prolonged discussions which took place, in the course of the ensuing ten or twelve years, before the Mesozoic age of the reptiliferous sandstones of Elgin was universally admitted. *Hyperodapedon* was destined to play no inconsiderable part in the controversy. Some ten years after the discovery of the original specimen, remains referable to the same genus were found in strata of unquestionably Triassic age in Central and Southern England; and, about the same time, I received abundant evidence of the occurrence of *Hyperodapedon*, associated with Dicynodonts, Crocodilia, and Labyrinthodonts, in certain Indian rocks which, on other grounds, were strongly suspected to belong to the oldest Mesozoic series. An account of these new materials, together with a full description of the original specimen of *Hyperodapedon*, was read before the Society and published in the 'Quarterly Journal' for 1869 †.

Unfortunately the type specimen, now in the Elgin Museum, was in very bad condition; and though, by careful study of the fossil itself, it was possible to make out all the most important features of the skeleton, the work of the artist employed to figure it turned out so unsatisfactory, that I abstained from publishing the two plates which were prepared for the Memoirs of the Geological Survey, thinking it wiser to wait until better materials should make their appearance. My discretion has been justified by the event, as a second specimen, of almost exactly the same dimensions as the first, was discovered in the Lossiemouth Quarries, and became the property of the British Museum some time ago. It has been worked out with a skill which my old experience of the nature of the matrix of these Elgin fossils enables me fully to appreciate, by Mr. Hall, and my friend Dr. Woodward has been so good as to place it in my hands for description.

* Quart. Journ. Geol. Soc. vol. xv. 1859, p. 460.

† "On *Hyperodapedon*," Quart. Journ. Geol. Soc. 1869, vol. xxv. p. 138.

I am glad to be able to say that, so far as it goes, the account of the structure of the skeleton of *Hyperodapedon* which I gave in 1869 needs no correction; but the new material enables me to make large and important additions. Moreover, several specimens of *Rhynchosaurus articeps* in the Palæontological Collection of the British Museum render it possible to make a full comparison of *Rhynchosaurus* with *Hyperodapedon*, and to put an end to any doubts which may have been entertained as to the generic distinction of the two. Finally, the full evidence now accessible permits us to obtain a clear view of the relations of both these extinct genera with the recent *Sphenodon*, a point to which I drew particular attention in 1869*. These relations, both of resemblance and of difference, are so interesting and important, in fact, that I shall give my account of *Hyperodapedon* mainly in the form of a comparison between that genus and *Sphenodon*.

The present specimen of *Hyperodapedon Gordoni* has been exposed by the splitting of a large block of sandstone into two slabs, along a plane which corresponds roughly with that of the imbedded skeleton. I have no information respecting the relative position of these slabs in the rock before it was quarried; but, supposing that slab which contains the larger part of the skeleton and the entire skull to have been uppermost, the animal lay flat upon its belly with its limbs standing out, very much as those of a dead Lizard ordinarily do, when it was buried in the sands of the Elgin shore. The skull, the vertebral column as far as the root of the tail, slightly curved towards the right side, almost the whole of the bones of the left (and part of the right) fore limb, with those of the right hind limb, are preserved in almost their natural relations.

The following table gives a view of the actual dimensions of *Hyperodapedon* and of the proportions of its parts compared with a specimen of *Sphenodon*:—

Measurements, in millimetres.

	<i>Hyperodapedon.</i>	<i>Sphenodon.</i>
Total length (Probably over 2000)		460
End of premaxilla to end of second sacral vertebra	900	208=(4·5 : 1)
Skull, end of premaxilla to edge of occiput	160	55=(3 : 1)
Skull, greatest breadth of the occipital region	210	34=(7 : 1)
Total length of humerus + radius	210	56=(4 : 1)
Total length of femur + tibia ..	200	66=(3 : 1)

Supposing the tail of *Hyperodapedon* to have been as long in proportion as that of *Sphenodon*, this specimen will have had a length of between six and seven feet, or rather more than four times as long as the specimen of *Sphenodon*. Hence it would appear that the

* *Loc. cit.* p. 147.

skull and the hind limbs were relatively shorter in the extinct reptile, but otherwise it must have had much the general aspect of its New-Zealand ally—only, as I shall have occasion to point out more fully by-and-by, the skull was relatively much broader and more massive and the feet were shorter and stouter in *Hyperodapedon*.

There are certainly 23 præsacral vertebræ in *Hyperodapedon*, perhaps 24, but I think not more; *Sphenodon* has 25. In both genera there are two sacral vertebræ.

In the first specimen, such of the thoraco-lumbar vertebræ as were preserved were split through the middle vertically and longitudinally. The sections of the centra showed that they were well-ossified throughout, and they appeared to be terminated by slightly concave contours. In the present specimen, the ventral faces of the cervical, and of some of the anterior thoracic, vertebræ are exposed and are almost uninjured; but from that which I reckon to be the 13th (though it may be the 14th) to the 20th, they are split horizontally and longitudinally, the dorsal halves lying in the upper slab and the ventral halves in the lower. The 21st, 22nd, and 23rd are similarly split, but they are much injured. Now the ends of several of these centra, notably the 13th, 14th, 18th, and 20th, present a sectional contour, which in front is more or less convex; while behind it is similarly concave. The anterior ends of the centra of the 4th (cervical) vertebra and of the 10th and 11th (thoracic) vertebræ appear to be strongly convex from side to side and their posterior faces correspondingly concave. Combining these appearances with those seen in the longitudinal section, I can only suppose that the surfaces must have been slightly cylindroidal, convex from side to side in front, and concave in the same direction behind; and thus that they approximated, though very distantly, to those of ordinary birds.

The remains of the slightly displaced atlas (Plate XXVI. fig. 7) are seen immediately behind the skull. It has the form of a ring 26 millim. wide and 20 millim. in vertical height. Traces of the os odontoideum are visible immediately in front of the ventral portion of the ring, which lies horizontally, with its ventral region turned backwards. The front half of the second cervical vertebra is broken away, but its centrum appears to have been about 20 millim. long. The ventral faces of the third and fourth are well displayed. Each is about 20 millim. long and 17 millim. wide at the ends, but not more than 13 millim. at the middle. On each side of the anterior end a short broad tubercle, which represents the transverse process, is developed. I can find no indication of the existence of intercentral ossifications. Each vertebra possesses a pair of strong ribs (Plate XXVI. fig. 8). These lie at the sides of the centra of the vertebræ and parallel with their length; so that, at first sight, the cervical region has a crocodilian look. The first rib on the right side is well seen. It is a straight styliiform bone, 40 millim. long and 3 millim. wide. On its dorsal side, and, more or less hidden by it, lies the second rib, the remains of which have about the same width and length. However, neither of these ribs

is complete at its extremities. The right rib of the third cervical vertebra is 38 millim. long and 10 millim. wide at its head, but it gradually tapers to a point at its ventral end. The fourth cervical vertebra has a rib of similar dimensions, but curved somewhat in the shape of an italic *f*. This great development of all the anterior cervical ribs is a point of contrast between *Hyperodapedon* and *Sphenodon*, in which last only rudiments of such ribs are discoverable.

The fifth cervical vertebra is almost completely hidden under the shoulder-girdle, behind which a vertebra makes its appearance, which I take to be the 9th, though it may be the 10th. The centrum of this vertebra is 20 millim. long, 25 millim. wide between the ends of the transverse processes in front, and 17 millim. wide in the middle of its length; and the centra of the three vertebræ which follow it have similar dimensions and appear to have concave posterior faces. These vertebræ have strong but short transverse processes. That of the 11th vertebra, on the right side, shows a rounded surface for the articulation of the head of the rib. The vertebral end of this rib is also well displayed; it is broad, measuring 20 millim. from its dorsal to its ventral margin, which is concave and thick, while the dorsal margin is thinner and convex (Plate XXVI. fig. 9). The vertebral end of a similar rib is visible on the right side, close to the 16th vertebra, and there are less well-preserved remains of others. These ribs are very similar to the corresponding ribs of *Sphenodon*.

Nearly the whole length of the rib which belongs to the 12th or 13th vertebra is shown; it is about 12 millim. broad, flattened and truncated at the sternal end; it measures 153 millim. along the chord of the arc of its curvature. The vertebral end is not completely exposed.

A thin flat plate of bone, 20 millim. long by 14 millim. wide, is seen on the right side, overlying the remains of two vertebral ribs, opposite the 14th vertebra. I suspect that this is a "processus uncinatus" such as those which occur in *Sphenodon*. The position of the skeleton is unfavourable for showing such bones, if they were preserved, and they would readily become detached. Portions of eight ribs, in undisturbed series, corresponding to the vertebræ from the 18th to the 22nd inclusively, are seen on the right side. It is possible that these may be the ends of vertebral ribs; but I incline to the supposition that they are sternal ribs, because the inner truncated end of each is in close relation with a bundle of five or six lateral abdominal ossicles, of which the central ossicles in each bundle are nearly straight, while the anterior and posterior describe elliptical curves. If these are really sternal ribs, they are very different, in form, from those of *Sphenodon**. It is by no means easy to arrive at a clear notion of the nature and arrangement of the abdominal ossicles, which extend over the ventral surface between the sternum and shoulder-girdle in front, and the pelvis behind. In front there is an area covered by ossicles of a V shape, the point

* Dr. Baur has stated that the abdominal ossicles of *Sphenodon* are connected by ligament in pairs with the sternal ribs, but I have not yet been able to satisfy myself of the fact.

of the V being turned forwards. The most anterior two of these are 4–5 millim. broad in the middle; but, behind, they become narrower in the middle and taper off to mere threads of bone at their outer and posterior ends. This area of V-shaped ossicles can be traced back for 90 millim. and is fully 120 millim. wide. Between the 15th and 20th vertebræ, narrow and nearly straight bands of bone appear to extend across the abdominal wall, and either to end in, or be connected with, the lateral ossicles already mentioned. The width of the area occupied by the abdominal ossicles, in this region, is not less than 220 millim. In front of the right pubis there are three broad curved plates, the inner ends of which turn forwards, and which fill up the space between the præpubic process and the position which would be occupied by the epipubic cartilage, if such existed. The posterior abdominal ossicles in *Crocodyles* are, as is well known, closely connected with the pubis. *Sphenodon* requires re-examination in relation to this point.

The sacral vertebræ are, unfortunately, much injured; but the centrum of the first (Plate XXVI. fig. 10) appears to be amphicoelous, the convex posterior face of the 23rd (or 24th) centrum fitting into it in front, and the convex anterior face of the second sacral fitting into it behind.

The rib of the first sacral vertebra measures 18 millim. transversely, and its expanded outer end 23 millim.

In the form of the articular surfaces of the centra, in the great development of the cervical ribs, and in the absence of intercentral ossifications, the skeleton of the trunk of *Hyperodapedon* departs from *Sphenodon* more widely than in any other particular.

The skull has been completely detached from the matrix, and all its most important characters are beautifully displayed.

Viewed from above (Plate XXVI. fig. 1), its contour presents the form of a broad-based isosceles triangle. The base, represented by the occipital region, measures 210 millim.; while the distance from the centre of that region to the rounded apex, formed by the conjoined premaxillary bones, is 160 millim. The hinder moiety of the dorsal region of the skull displays the great supratemporal fossæ (*s.t.*), which are somewhat rounded (50 millim. wide and 58 millim. long), and are separated by the relatively narrow parietal region of the skull (20 millim. wide), which presents no parietal foramen. In the front moiety, the orbits (*or.*), of a half-oval shape (50 millim. long and 30 millim. wide), are separated by the broad frontal portion of the skull, which is 40 millim. wide. In front of these, again, and of the broad and short nasal bones, is the single anterior nasal aperture (*a.n.*), which is triangular, with the apex forwards, and is 20 millim. broad by 24 millim. long. In the living animal, this opening would have been divided into two by the nasal septum; but, no doubt, this was entirely cartilaginous, and hence, in the fossil, the aperture appears single. Laterally, it is bounded by a strong ascending process of each premaxilla.

In this respect there is a very marked difference between *Hyperodapedon* and *Sphenodon*. In the latter, the median end of

each premaxilla sends up a broad and strong process, which, united with its fellow, ascends in front of the nasal septum to the nasal bones, and thus the two nasal apertures become widely separated by bone. Laterally, on the other hand, the premaxillæ are united with the maxillæ by a short process, which has no ascending branch.

In *Hyperodapedon*, as in *Sphenodon*, the median end of the oral face of each premaxilla is elongated downwards into a recurved process (Plate XXVI. figs. 2, 3, 5, *r.p.*); and the two processes, closely applied together by their inner surfaces, form the beak, or rostrum, in which the upper jaw terminates. In *Sphenodon*, these rostral processes are broad and flattened from before backwards. Their broad truncated ends descend but little beyond the dentary edge of the mandible, when the mouth is shut, and present two tooth-like eminences. Moreover, their inner sides, closely applied through the greater part of their length, diverge so as to leave a median notch below. In *Hyperodapedon*, the rostral processes are thick and semicircular in section, the inner, mutually applied, sides being flat and the outer faces convex. Each tapers to its extremity, and the apices of the two are conjoined to form the sharp conical extremity of the beak. The rostrum, as a whole, is much more curved than in *Sphenodon*, and descends far lower in front of the mandibular symphysis. There is no dentary substance upon any part of the rostrum of *Hyperodapedon*; and the aspect of its external surface leads me to believe that it was coated with a horny sheath.

In *Sphenodon*, the anterior end of the mandible lies altogether behind the broad premaxillary rostrum, when the mouth is shut. In *Hyperodapedon*, on the contrary, the rostrum is received between the rostral processes of the mandible.

The lateral view of the skull (Plate XXVI. fig. 2) shows that the orbits looked more upwards in *Hyperodapedon* than in *Sphenodon*; the lateral temporal fossæ (*l.t.*) are relatively much smaller and have a very peculiar ear-like contour, while the bony boundaries of these parts are much stronger. In *Hyperodapedon*, I can find nothing but bone in the region which should be occupied by the posttemporal fossæ. The contour of the alveolar edge of the maxilla in *Sphenodon* is slightly convex downwards and slightly concave inwards. In *Hyperodapedon*, the contour is very strongly convex both downwards and inwards, and this feature, combined with the great length and recurvature of the premaxillary rostrum, confers a very peculiar aspect on the skull (see figs. 1 & 3, p. 682).

In the under view of the skull of *Sphenodon* (fig. 6, p. 683), the maxillary and palatal regions present little difference from those of ordinary Lizards. The palatal area slowly widens from before backwards, and its maxillary boundaries are slightly concave inwards. Running parallel with the posterior half of each of these is the dentigerous ridge of the palatal bone, bearing a single series of some seven or eight teeth, which, like those of the maxilla, are acutely conical. Between these and the posterior maxillary teeth is the deep groove

into which the mandibular teeth are received. The palatal and maxillary teeth of opposite sides are separated by the widest part of the palatal area, formed by the pterygoid bones in the middle, and the palatals at the sides. The long oval posterior nares are wide and conspicuous, occupying, as they do, the greater part of the space between the anterior end of the palatal series of teeth and the premaxillary rostrum (see fig. 6, p. 683).

In *Hyperodapedon* (Plate XXVI. fig. 3) the alveolar edges of the maxillæ describe a curve which is strongly convex towards the middle line, and correspondingly concave outwards. Their posterior ends are very far apart, but in the anterior halves of their extent they approach so closely as to leave only a narrow palatal area. At their anterior ends they again slightly diverge. Behind, three longitudinal rows of obtusely conical teeth are set between the groove for the mandible and the outer margin of the maxilla, but only one of these rows is continued forwards along the anterior half of the length of the maxilla (see fig. 4, p. 683).

The space included between the mandibular groove and the curved posterior boundary of so much of the dentigerous area of the palatal bones as is left visible in the specimen by the dislocated mandible is occupied on each side by four rows of obtusely conical teeth, which take a direction roughly parallel with one another and with the series of maxillary teeth. Only one of these series of teeth is continued forward alongside of the single part of the series of maxillary teeth.

The palatal bones are undistinguishably united, either with the pterygoids, or over them, in the anterior narrow part of the palate, which ends in a semilunar margin, concave forward. The space between this and the posterior face of the root of the premaxillary beak is, for the most part, filled by a broad plate of bone which represents the vomers. The posterior nares must have been very small; but, on the left side, between a concave edge of this vomerine plate, on the inner side, the premaxilla, in front, and the maxilla, externally, there is a small aperture, which I take to be the posterior nasal opening (Plate XXVI. fig. 3, *p.n.*). The articular condyles of the quadrate bones are elongated from side to side, and present cylindroidal surfaces. They lie about 25 millim. behind a vertical line drawn from the occiput, when the roof of the skull is horizontal.

In *Sphenodon* (see fig. 3, p. 682) the rami of the mandible appear nearly straight in the greater part of their length, both in the lateral and the ventral aspects. In the latter, their anterior ends present a sudden incurvature towards the symphysis, which is not longer than in ordinary Lizards; and, as in them, the union of the rami is effected by ligament. The contours of the alveolar edges of the rami have an upward concavity, which is so slight as to be hardly perceptible; and, viewed from above, they form a narrow arch with nearly straight sides. The inner and superior angle of the symphyseal end of each ramus is separated by an interspace from its fellow, above the symphysis. The surface of the ramus at this part is tooth-like in aspect, from the density of the bone of which it is composed. Externally, just where the bent portion of the ramus passes into the

Figs. 1-6.—*Diagrammatic views of the Skulls of Hyperodapedon, proportions*

Fig. 1.—Skull of *Hyperodapedon*, side view.

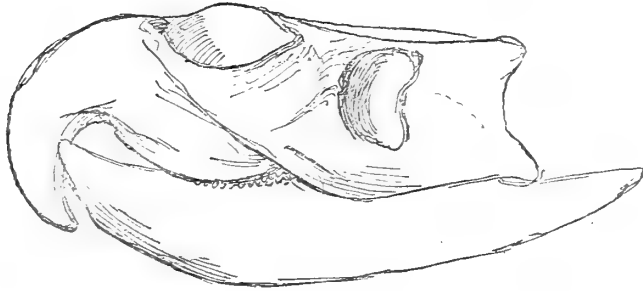

Fig. 2.—Incomplete Skull of *Rhynchosaurus*, side view.

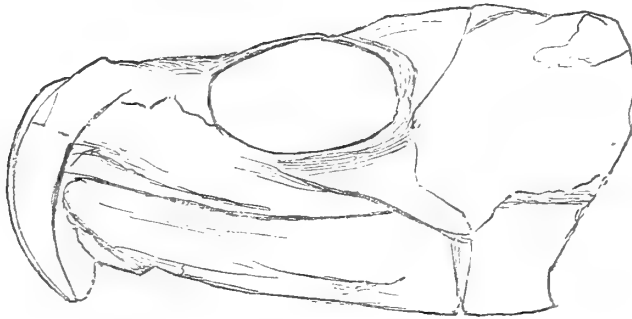
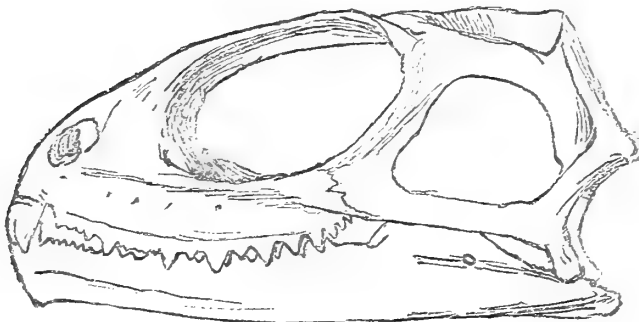

Fig. 3.—Skull of *Sphenodon*, side view.



straight part, there is a strong conical tooth, the base of which is imbedded in the substance of the ramus. This is followed by a series of distinct, acutely conical, teeth (also ankylosed to the jaw); these increase in size backwards up to the last three, which gradually diminish. The anterior six or seven of these teeth are very close set, but quite separate.

In *Hyperodapedon*, the mandibular rami are extremely massive, and are ankylosed together in front, throughout their long symphysis

Rhynchosaurus, and Sphenodon, illustrating the variations in their and form.

Fig. 4.—Skull of *Hyperodapedon*, under view.

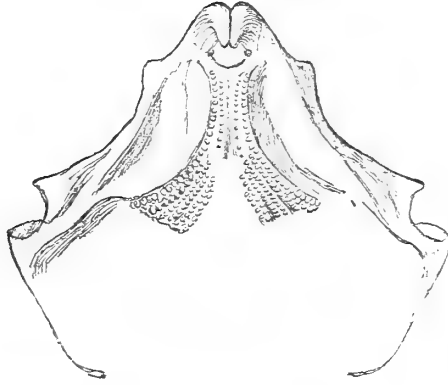

Fig. 5.—Skull of *Rhynchosaurus*, under view.

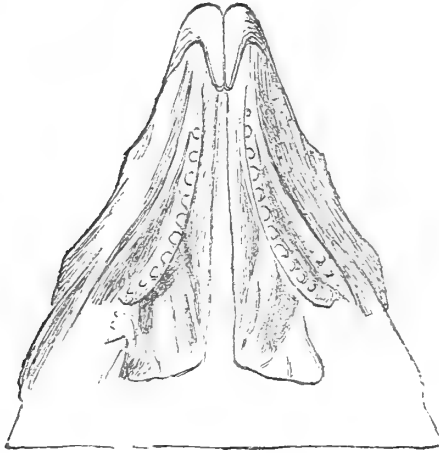
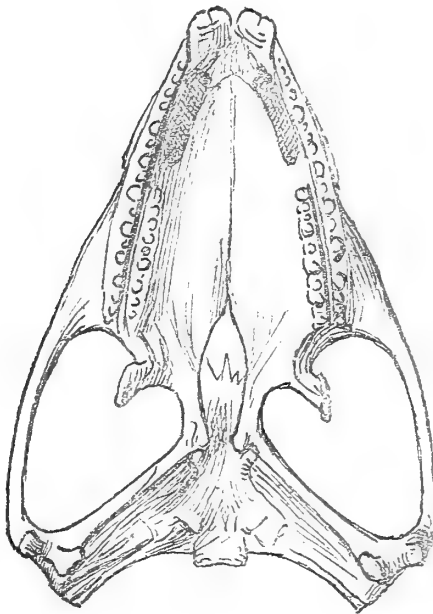

Fig. 6.—Skull of *Sphenodon*, under view.



(Plate XXVI. fig. 4). The anterior and superior angle of each is prolonged into a "rostral" process (*r.m*), which passes upwards, outwards, and forwards. The two thus leave a wide V-shaped interval,

into which the end of the premaxillary beak is received when the mouth is shut. These mandibular rostral processes were probably clothed, like the premaxillary rostrum, with horn; and, with the interlocking premaxillary beak, must have constituted a pair of pincers of great strength. Behind this forked mandibular beak, the upper contour of each ramus is strongly concave upwards, in correspondence with the maxillo-palatal convexity, and its close-set teeth are worn to a sharp scissor-edge, which fitted into the fore part of the mandibular groove of the upper jaw. Throughout the symphyseal region, the two rami lie close together and form a parallel-sided body of the width of the fore part of the palate; but, behind, the rami diverge, sweep outwards in a curve which corresponds, at first, with that of the mandibular groove in the broad part of the palate, and then pass to their articulation with the quadrate. The angle of the ramus appears to have extended considerably behind this articulation, but its exact length and shape cannot be determined.

The alveolar edges of the rami begin to show teeth rather behind the middle of the symphysis, and the series of teeth extends for 60 millim. behind this point. In the front part of the series, the teeth are so close-set as to form a palisade-like continuous ridge, worn upon the two faces to a sharp edge. There are about 6 teeth in a length of 10 millim., and each tooth is 5 millim. high, but at about 7 millim. from the hinder end of the series the teeth become separate. Here they present rounded summits and their outer surfaces are convex and unworn (Plate XXVI. fig. 6).

Measurements of parts of the Skull of Hyperodapedon in millimetres.

Nasal aperture,	27 long by 24 broad at the base.
Orbit,	48 long, 35 wide.
Narrowest part of interorbital region,	40.
Supratemporal fossa	50 long, 45 wide.
Parietal region	20 wide.
Lateral temporal fossa	23 wide, 41 in perpendicular depth.
Premaxillary rostrum	25 thick at the base from before backwards.
" " " " " "	30 broad from side to side.
" " " " " "	35 in a straight line from base to apex.
Extreme width of dentigerous area	93
" length " " " " " " " " " "	82
Width of alveolar face of posterior end of maxilla	14
" " " " " " " " " " " " " " " " "	palatal 24
Diameter of the bases of teeth	3 to 4
Length of symphysis of mandible	56
Breadth of middle of symphysis of mandible at narrowest	} 23
between the anterior parts of the dentary edges	
Depth of the rami at this part	30
Length of each half of the mandibular rostrum from base.	20
Greatest depth of ramus from the dentary edge to the	} 45
lower border	
Total length of ramus, probably	190
Posterior nares	6 wide by 4 long.

Fig. 7.—*Hyperodapedon Gordoni*.
Mr. Grant's specimen.
Left side.

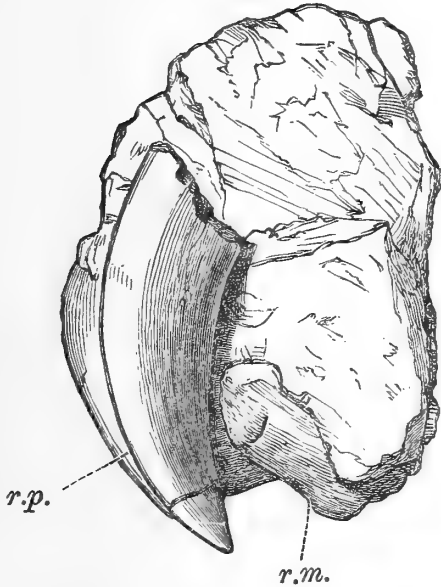
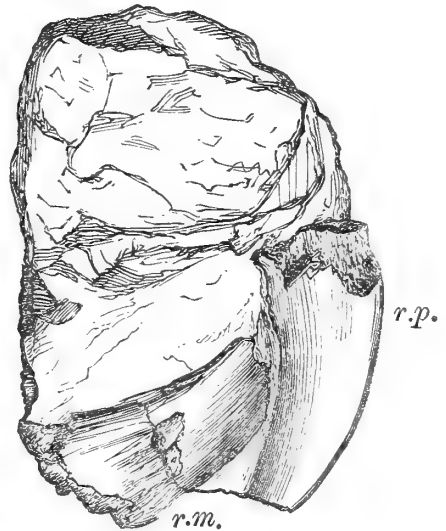

Fig. 8.—*Hyperodapedon Gordoni*.
Mr. Grant's specimen.
Right side.



Dr. Woodward has afforded me the opportunity of examining a very instructive, though fragmentary, specimen of the fore part of the skull of a large *Hyperodapedon*, the property of Mr. Grant, of Lossiemouth. The premaxillary rostrum is nearly entire and in connexion with the facial bones, as far as the anterior boundary of the orbit on the left side. The anterior end of the left ramus of the mandible, with its rostral process nearly entire, is almost in place (fig. 7), and on the opposite side of the matrix there is the almost complete impression of the right mandibular rostral process (fig. 8). Moreover, a cast of the outer surface of the left rostral process of the premaxilla is preserved in one of the halves of the matrix. The left rostral process itself is quite free, and can be lifted out and examined on all sides. Including the anterior extremity, of which only the impression remains, it is 57 millim. long, 23 millim. deep, and 13 millim. thick at its proximal end. The anterior face is more strongly curved than the posterior, and somewhat flattened, and it is rather obtusely pointed at its free end. The inner face is flat, and was evidently closely applied to that of the opposite rostral process in the greater part of its extent; but, in the course of fossilization, a thin layer of matrix has been interposed between the two. About the posterior third, the inner face of each rostral process slopes sharply outwards, and the upper margin becomes rounded as it bounds the external nares. Both the inner and the outer surfaces of the bony substance of the rostral processes are marked by fine close-set longitudinal grooves, and the surfaces of the rostral processes of the mandible present similar markings.

The convex face of the left premaxillary rostral process fits closely into the concavity of the cast, to which I have referred, and presents fine longitudinal ridges which answer to the grooves on the surface

of the bone. I conclude, therefore, that the soft parts and any horny sheath that may have existed must have decomposed and left the bone bare before the sandy matrix set round the imbedded skeleton.

Of the bones which enter into the composition of the shoulder-girdle of *Hyperodapedon*, the specimen presents remains of the interclavicle and the clavicle, the coracoid, and the scapula. The interclavicle is a long narrow bone, thin and spatulate towards its posterior end. The anterior end bends somewhat sharply towards the dorsal side; but the shape of its extremity, and whether it was provided with transversely elongated lateral processes or not, cannot be ascertained. On the left side it is in connexion with a strong and long curved bone, which is obviously a clavicle. Nothing more than the edge of a bone which I take to be the scapula can be seen, but the left coracoid is well preserved. It is a cheesecutter-shaped bone, with a broad blade and a comparatively narrow neck, which widens out again to the glenoidal extremity.

In *Sphenodon*, the anterior end of the interclavicle is not bent upwards, and is produced into two strong transverse arms, with which the clavicles are articulated. The scapula and the coracoid very early became undistinguishably united; while, in *Hyperodapedon*, they appear to have remained, as usual, separate.

The principal bones of the left fore limb are seen nearly in their natural relations (Plate XXVI. fig. 11).

The humerus has a widely expanded proximal end of a rhomboidal shape. In the middle, the shaft is rounded for a short distance and then expands into the broad and thick distal end, the ventral face of which presents a deep intercondyloid fossa. On the inner side there are indications of a "median" canal. The ulna is stout, with a prismatic olecranon prominence, and is somewhat curved longitudinally so as to be concave to the interosseous space. The radius is more slender and nearly straight.

The structure of the carpus is not recognizable. The five metacarpals are preserved in various conditions of completeness. The most remarkable feature about them is that they do not seem to have differed to any notable extent in length (17 millim.); but while the first, second, and third are proportionally very broad (about 10 millim.), the fourth has a width of not more than 7 millim., and the fifth of 5 millim.

The humerus, radius, and ulna in *Sphenodon*, though more slender, are very similar; but the ulna is longer in proportion to the radius; the first metacarpal is considerably shorter and at the same time thicker than the second, while the second and fourth are a little shorter than the third, and the fifth is about as long as the first; and all have much slenderer proportions than those of *Hyperodapedon*. The fore foot of the extinct Lizard must in fact have been remarkably short and thick in its proportions.

Measurements of the Shoulder-girdle and Fore Limb in millimetres.

	<i>Hyperodapedon.</i>	<i>Sphenodon.</i>
Interclavicle, length.....	90 (about)	31
" greatest width....	17	3
Clavicle.....	100 (about)	20
Coracoid, length.....	58	
" breadth.....	42	11
Humerus, length.....	130	33
" width at proximal		
end.....	62	11
" " at distal end..	?	11
" shaft in the middle..	20	2.5
Radius, length.....	74	20
" width, proximal.....	20	4
" " distal.....	13	4
Ulna, length.....	74	25
" width, proximal.....	30	5
" " distal.....	20	5
Metacarpals:—		
i. }	6.5
ii. }	9.5
iii. }	17	11.0
iv. }	10.0
v. }	6.0

The right half of the pelvis is exposed; but the pelvic bones are a good deal crushed, and it is difficult to arrive at an unquestionable interpretation of the appearances they present. There is no doubt, however, as to the position of the obturator foramen, bounded in front by the pubis and behind by the ischium. The former bone (Pl. XXVI. fig. 12, *pb*) is transversely elongated, and somewhat narrow in the middle; it widens out at both ends. At the inner extremity it is flat and thin, and presents a convex symphyseal contour. At the outer extremity it is developed forwards into a strong prepubic process and backwards into a thick acetabular portion. The bone is therefore quite Lacertilian. The thick acetabular portion of the ischium (Plate XXVI. fig. 12, *is*) is in connexion with that of the pubis, and the concave obturator margin of the bone can be well made out. The difficulty is to say how much of the mass of bone which lies behind this point (*x*, fig. 12) belongs to the ischium and how much to the ilium, which seems to be crushed down upon the ischium. If, as appears probable, the posterior contour of the ischium is indicated by the curved depression (*aa*, fig. 12), the ventral half of the pelvis will be quite like that of ordinary Lizards, and the rest of the bony matter belongs to the ilium. On the other hand, the form of the ischium in *Rhynchosaurus* rather leads to the supposition that the ischium was expanded inwardly and prolonged further backward, so as to be unlike that of *Sphenodon*.

The chief bones of the right hind limb (Plate XXVI. fig. 12) are

fairly well seen. The femur is directed forwards, outwards, and dorsad, its proximal end being close to the acetabulum. The bones of the leg are sharply bent at the knee, where they lie close to the distal end of the femur, but slightly dislocated backwards. At their distal ends they are in close proximity to the remains of the tarsus and metatarsus. The femur is a short and stout bone, bent so as to be slightly concave on the ventral and convex on the dorsal surface. The proximal end is a good deal injured, but it obviously expanded to its articular surface and was quite Lizard-like. The middle of the shaft is rounded and little more than half the diameter of the ends of the bone. The inner condyle is stouter than the outer, and between the two there is a deep intercondyloid depression. At about the junction of the middle with the proximal third, the ventral face exhibits a longitudinal elevation, which I take to be the commencement of a strong trochanteric ridge, such as exists in *Sphenodon*. The tibia and fibula are not fully exposed, but the former must have been much shorter than the femur; the distal end is trihedral; the middle of the shaft is flattened, and the proximal end somewhat expanded. The fibula seems to have had a similar form, but it was much more slender. Only fragments of the tarsal bones are preserved.

There are indications of five metatarsals, only three of which are represented in Plate XXVI. fig. 12. They increase in length from the first to the third, if not to the fourth. The first is 17 millim. long, the second 35 millim., the third 45 millim., and each has a breadth of about 10 millim. Of the fourth only an imperfect impression of the proximal half remains. These four metatarsals lie close together and parallel with one another. The fifth digit was set at a distance from the fourth, as is usual in Lizards, but only the impression of the characteristically broad basal end of the fifth metatarsal is preserved*. The first phalanx of the first digit is 14 millim. long, and the second seems to have had about the same length. There are two fragmentary phalanges of the second and third digits respectively.

Measurements of the Pelvis and Hind Limb.

	<i>Hyperodapedon.</i>	<i>Sphenodon.</i>
Pubis from acetabulum to medial edge	74	19
Femur, length	121	40
„ breadth, proximal end	41	8
„ „ middle	23	3
„ „ distal end	36	8.5
Tibia, length	80	26
Fibula, length	80 (about)	25.5
Metatarsal i.	17	8
„ ii.	35	12.5
„ iii.	45	15

* The indications of the structure of the metatarsus which I have interpreted as above, are somewhat obscure. Even with large-sized figures, their value could hardly be estimated without examination of the original.

It is obvious, even from these imperfect data, that the hind foot of *Hyperodapedon* was longer than the fore foot, though shorter in proportion than that of *Sphenodon*. It seems also in the gradation of the digits to have departed less from the ordinary Lacertilian foot than the fore foot does.

The comparison of all parts of the skeleton, which has now been made, leaves no doubt as to the close relations between *Hyperodapedon* and *Sphenodon*. At the same time it makes clear the existence of a number of differences, of which the following appear to me to be the most important:—

1. The centra of the præsacral vertebræ are ossified throughout and more or less opisthocœlous, especially in the cervical region. Moreover there are no intercentral ossifications.

2. The anterior cervical vertebræ have long and strong ribs.

3. The external nares are not separated by bone.

4. The conjoined premaxillary processes form a long, conical, curved, pointed rostrum, which is received between two rostral processes of the mandible. All these were devoid of teeth, and probably ensheathed in horn.

5. The palatal area is very narrow in front and wide behind, with strongly curved lateral boundaries.

6. The posterior maxillary and palatal teeth are multiserial.

7. The rami of the mandible are united in a long symphysis, behind which they diverge widely, and their dentigerous edges are strongly concave upwards as well as outwards.

8. The mandibular teeth are set into a close, apparently continuous palisade in front, and they become distinct and conical only at the posterior end of each series.

9. The fore foot is remarkably short and stout, with metacarpals of equal length. I find no evidence of the existence of an "ect-epicondylar foramen" in the humerus.

Rhynchosaurus, although allied to *Hyperodapedon*, is sharply distinguished from the latter by its vertebral and cranial characters; and, in some respects, it occupies an intermediate place between *Hyperodapedon* and *Sphenodon*.

A specimen in the British Museum (to which I shall refer as No. 1) shows the head and trunk in almost undisturbed relation, though much damaged in some parts. The length, from the snout to the sacrum, could not have exceeded 280 millim.; so that the animal was only a little larger than the specimen of *Sphenodon* of which the measurements are given above; and, as the skull was about 80 millim. long, it had about the same proportion to the trunk as in *Sphenodon*.

The centra of the thoraco-lumbar vertebræ are about 10 millim. long and amphicœlous. They present, at each end, a hemispherical concavity, each of which occupies about a fourth of the length of the centrum, the two middle fourths being occupied by bone. No specimen which I have seen shows the characters of the centra of the cervical or sacral vertebræ, nor throws any light upon the question

of the existence of anterior cervical ribs. There is no evidence of the occurrence of intercentral ossifications.

The abdominal ossicles, so far as they are visible, resemble those of *Hyperodapedon* and *Sphenodon*, but no specimen I have seen enables their details to be satisfactorily made out.

The skull, in its general characters, resembles that of both *Hyperodapedon* and of *Sphenodon*. In contour, it is intermediate between the two, having the occiput relatively somewhat broader than in *Sphenodon* and much narrower than in *Hyperodapedon*.

The anterior nasal aperture is single, as in *Hyperodapedon*, and the strong recurved premaxillary rostrum has essentially the same structure, and probably was ensheathed in a horny envelope. On the other hand, the dentary edge of the maxilla is but very slightly convex downwards; and, viewed from below, there is a corresponding difference from *Hyperodapedon*. The outward lateral concavity and inward convexity of the dentary edges of the maxillæ are very slight, and consequently there is no such anterior narrowing and posterior widening of the palatal surface as in *Hyperodapedon*. The palatal bones are not fully exposed in any specimen, but in one there is evidence that they bear certainly not more than two longitudinal rows of teeth, perhaps only a single row; consequently they are narrow, as in *Sphenodon*; and, as in the latter genus, leave the anterior portions of the pterygoid bones, which lie between them, uncovered (Plate XXVII. fig. 1, *pt*). The symphysis of the mandible is relatively short, and the rami do not curve outwards as they do in *Hyperodapedon*. The mandibular rostral processes, between which the premaxillary rostrum is received, are short and obtuse (see fig. 2, p. 682).

Thus the skull of *Rhynchosaurus* resembles that of *Hyperodapedon* and differs from that of *Sphenodon*, in its single anterior nasal aperture, its premaxillary and mandibular rostral processes, and, perhaps, in possessing more than one series of palatal teeth; but, in general form, and in the shape of the maxillæ, palatal bones, and rami of the mandible, it departs far less from *Sphenodon* than *Hyperodapedon* does. In another respect, *Rhynchosaurus* appears to differ from both *Hyperodapedon* and *Sphenodon*, in that no distinct teeth are discernible on the dentary edges either of the maxillæ or of the mandible. Without microscopic examination of sections of the parts, it is impossible to say whether the maxillæ and the mandible of *Rhynchosaurus* were really edentulous or not. If they were, this genus will present an interesting approximation to the Anomodontia.

Two other specimens (No. 2, and its counterpart, No. 3) display the coracoids (*co*) in place (Plate XXVII. fig. 3). These bones are broad and expanded, 34 millim. long and 20 millim. wide, and have convex median edges. Close to this edge of the right coracoid (in No. 2) lies the interclavicle (*i.cl.*), 30 millim. long. It is narrow, blade-like, and bent dorsad at its anterior end. Here it expands transversely into two arms, which are short, but are not improbably broken. The clavicles are wanting, unless the part marked *cl.* in fig. 3 represents one.

In the specimen of *Rhynchosaurus* to which I have already referred

as No. 1, much of the skeleton of the right fore limb is preserved. The right humerus is 40 millim. long, and has widely expanded proximal and distal ends. The radius has about the same length. There are more or less well-preserved remains of five metacarpals. The first has about half the length of the second, which is about equal to the third.

In the specimen (No. 2) all five digits of the manus are displayed. The fifth metacarpal, which is broad and short, as in *Sphenodon*, and three or four of the phalanges of the fifth digit are in place (Plate XXVII. fig. 3). In all respects, this foot is more like that of *Sphenodon* than that of *Hyperodapedon*.

The impressions of the ischia are very well shown in No. 3 (Plate XXVII. fig. 4, *is*). They are broadly triangular in shape, with the angles rounded off. The symphyseal side is 25 millim. long; while, from the symphysis to the acetabulum, transversely, the bone measures 20 millim. In front of the left ischium there is seen, in the place which ought to be occupied by the pubis, the impression of a broad flat plate (Plate XXVII. fig. 4, *pb*), 25 millim. from side to side by 10 antero-posteriorly, the posterior edge of which is, for its inner two thirds, in close contact with the front edge of the ischium, leaving only a small space to represent the obturator foramen. I cannot take this impression to represent anything but the pubis, though its form and position are somewhat unusual. The femur is 57 millim. long, and the shaft is curved like an \int . The tibia and fibula are each 50 millim. long. The astragalus and calcaneum are separate (as in *Sphenodon*), and have the ordinary Lacertilian form. A large distal tarsal bone (as in *Sphenodon*) affords an articular surface for the fifth metatarsal, which, with the four phalanges of its digit, is preserved (Plate XXVII. fig. 4, *v*). This digit differs but little in size and form from the corresponding digit in *Sphenodon*; and it is therefore remarkable that the fourth metatarsal of *Rhynchosaurus* is very much broader than that of *Sphenodon*, and half as long again. The third and second metatarsals are nearly as broad, but shorter. The first is relatively shorter and thicker (Plate XXVII. fig. 5).

Two imperfect series of tail-vertebræ show that, in the anterior caudal region, the vertebræ were provided with long and strong chevron bones (Plate XXVII. fig. 2).

The evidence which has now been adduced appears to me to prove that *Hyperodapedon*, *Rhynchosaurus*, and *Sphenodon* constitute a peculiar group of Lacertilia, the skeletons of which are distinguished from those of all other recent or extinct known forms by the combination of the following characters, namely:—the premaxillary rostra; the longitudinal series of palatal teeth, bounding a groove, between which and the maxillary teeth the hinder mandibular teeth are received; the abdominal ossicles; and the absence of procœlous præsacral vertebræ. This group of *Sphenodontina* falls into two families, the *Rhynchosauridæ* and the *Sphenodontidæ*.

The *Rhynchosauridæ* have a single external nasal aperture

edentulous premaxillary and mandibular rostra, probably covered with horn, the former received between the latter; sometimes more than one series of palatal teeth; and either amphicœlous, or more or less opisthocœlous, præsacral vertebræ.

This family contains *Hyperodapedon* and *Rhynchosaurus*, readily distinguished by the cranial, vertebral, and dental differences given above.

The *Sphenodontidæ* have divided external nares; a toothed premaxillary rostrum, not horn-covered, nor received between mandibular rostral processes; a single series of palatal teeth; and amphicœlous vertebræ.

It is very interesting to observe that, so early as the Triassic epoch, the group of the Sphenodontina had attained its highest known degree of specialization, *Hyperodapedon* being in all respects a more modified form than *Sphenodon*. It appears a probable conclusion that in the Permian epoch or earlier, Lacertilia existed which were less different from *Sphenodon* than either *Hyperodapedon* or *Rhynchosaurus*.

I am unable to discover any feature in the organization of either *Hyperodapedon* or *Rhynchosaurus* which supports the supposition, sometimes entertained, that these reptiles departed from the types of structure found among existing Lacertilia in any greater degree than these (e. g. *Monitor*, *Chamæleo*, *Gecko*, *Sphenodon*) do from one another, or that they present any approximation to other Orders of Reptilia.

The evidence now offered concurs with that afforded by the structure of *Telerpeton*, in establishing the belief that the Lacertilian type of organization had, in the Triassic epoch, attained perfectly clear definition from all others; and it further shows that, in *Hyperodapedon*, the type had attained a degree of specialization on a level with that exhibited by any modern Lizard.

The relations of the Sphenodontina with other groups of Reptiles of approximately the same age, in which the anterior ends of the jaws tend to assume the characters of a beak, with or without palatal teeth (*Dicynodon*, *Endothiodon*), and with such forms as *Placodus*, cannot, I think, be profitably dealt with until more is known of the organization of the latter. I may add that I am unable at present to see any good grounds for the approximation of *Simædosaurus* to *Hyperodapedon*.

In his valuable account of the Indian species of *Hyperodapedon* ('Indian Pretertiary Vertebrata,' vol. i. 1885), Mr. Lydekker assigns various detached bones to this genus on very fair grounds of probability. The absence of intervertebral ossifications in *H. Gordoni*, however, would seem to diminish that probability so far as the vertebræ are concerned.

EXPLANATION OF THE PLATES.

PLATE XXVI.—*Hyperodapedon Gordoni*.

- Fig. 1, 2. Upper and lateral views of the skull. $\frac{1}{2}$ nat. size.
 3. The palatal surface of the skull, so far as the adherent mandible permits it to be seen. $\frac{1}{2}$ nat. size.

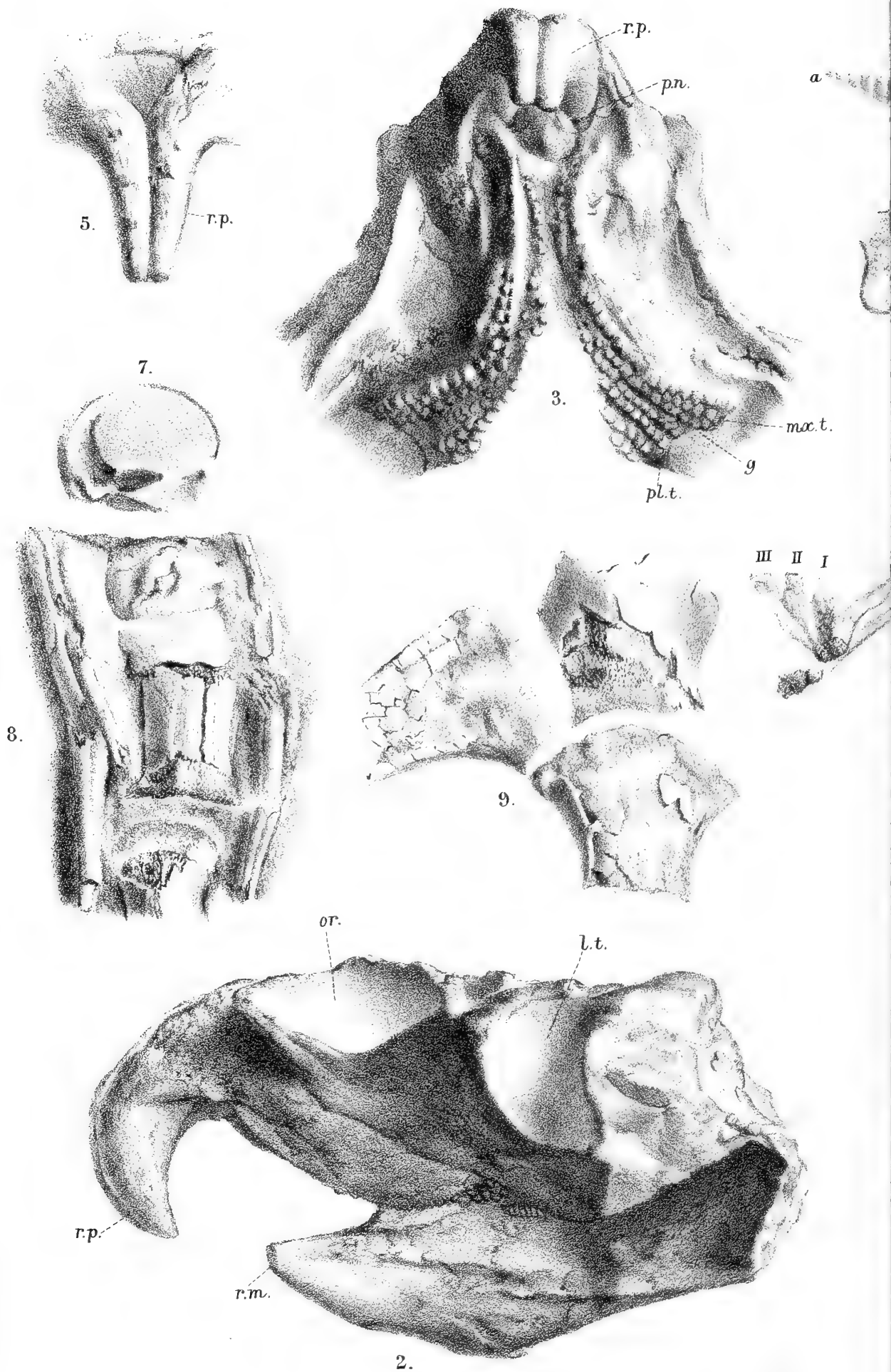

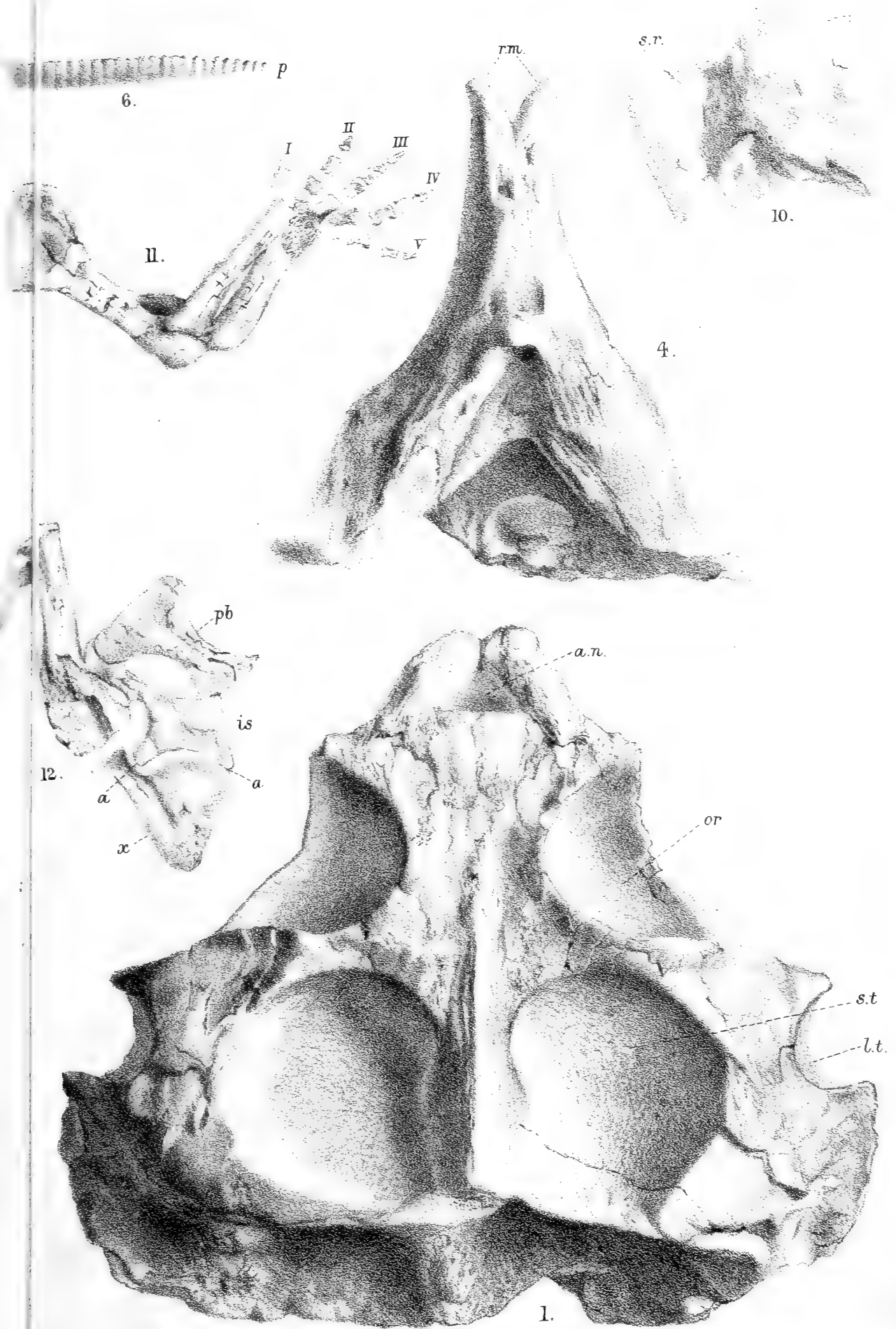



F. H. M. de la. Geol. et Min.

Mintern Bros. imp.

RHYNCHOSAURUS ARTICEPS.

- Fig. 4. Under view of the mandible. $\frac{1}{2}$ nat. size.
 5. Front view of the premaxillary rostrum and the anterior nares. $\frac{1}{2}$ nat. size.
 6. Series of mandibular teeth: *a*, anterior, *p*, posterior end. Nat. size.
 7. The remains of the atlas, and fig. 8, the succeeding cervical vertebræ. Nat. size.
 9. Præsacral vertebræ, with the proximal end of a rib. Nat. size.
 10. The remains of the first sacral vertebra. Nat. size.
 11. The left fore limb. $\frac{1}{4}$ nat. size.
 12. The right hind limb. $\frac{1}{4}$ nat. size.

PLATE XXVII.—*Rhynchosaurus articeps*.

- Fig. 1. Under view of an imperfect skull. Nat. size.
 2. A series of caudal vertebræ. Nat. size.
 3. The right shoulder-girdle, ventral aspect (No. 2), and the left fore limb, dorsal aspect (No. 3). Nat. size. It is doubtful whether *cl* is really the clavicle.
 4. Impressions of the left pubis and ischium, and remains of the bones of the left hind limb as they lie in No. 3. Nat. size.
 5. Right hind foot, ventral aspect (No. 1). Nat. size.

DISCUSSION.

The PRESIDENT remarked that he felt he only expressed the sentiments of all the Fellows present in welcoming back their past President to the scene of his former triumphs. The type specimen of *Hyperodapedon* was so imperfect that it was marvellous the characters ascribed to the genus required so little modification in consequence of the far more perfect specimen now described.

Mr. HULKE could only re-echo the President's congratulations on the reappearance of Prof. Huxley. He could but admire the clear manner in which this very interesting reptile had been described by him.

Dr. GEIKIE recalled the early controversies about the age of the Elgin Sandstones, and pointed out that no satisfactory stratigraphical solution of the puzzle had yet been found. A line between the beds with Mesozoic Reptilia and those containing *Holoptychius* would never have been drawn but for the extraordinary contrast of the organic remains. By physical characters it was not possible to separate them.

Prof. SEELEY said that caution was necessary in concluding that such types were limited to one system. The Reptiles of South America associated with *Lepidodendron* and *Schizodus*, partly described by Prof. Cope, have close affinity with some from South Africa which are usually regarded as Triassic.

The form of articulation of the vertebræ being merely generic in Amphibia, it is not surprising to find that some reptiles have opisthocœlous vertebræ. Some recent lizards also show peculiar forms of the abdominal ribs, as in *Plesiosaurus*, which are present in many Triassic reptiles, though enveloped with matrix, so as to form abdominal rods like those seen in this fossil. In conclusion, he spoke of the satisfaction he experienced in once more hearing Mr. Huxley.

Mr. LYDEKKER noticed the occurrence of *Hyperodapedon* in India associated with *Parasuchus* and *Belodon*; but the associated ver-

tebræ are amphicœlous. The maxillo-palatines appeared perfectly similar, more so than he at first believed; indeed there was scarcely apparent specific difference between those described by him and those of the new Elgin specimen.

Mr. WHITAKER wished to thank Prof. Huxley for the good lesson given by the absence of dogmatism in his paper.

Dr. BAUR inquired as to the development of the parietal foramen.

Prof. HUXLEY said that he could not find a trace of any such foramen in *Hyperodapedon*.

Dr. BAUR said that this showed the specialization of *Hyperodapedon*. *Simœdosaurus* or *Champsosaurus* must have some relation to *Sphenodon*, but it is also a specialized form. He pointed out some vertebral points of similarity between the former and *Sphenodon*.

With regard to the systematic position of *Hyperodapedon* and its allies he would prefer putting them under the Rhynchocephalia apart from Lacertilia as a group equivalent to Ophidia and Mosasauria.

Dr. BLANFORD described the relative position of the *Hyperodapedon*-beds in India, showing that they were, in all probability, later than the *Dicynodon*-beds, and closely allied, if not identical, with the beds containing fishes of Liassic type. He also noticed that *Uromastix*, an agamoid lizard which shows some points of resemblance in dentition to *Hyperodapedon*, is exclusively herbivorous.

Prof. BOYD DAWKINS said that Mr. Charles Moore's examination of the Rhætic strata which overlie the *Hyperodapedon*-beds of Elgin, proved that the latter occupied *the same palæontological horizon* below the Jurassic series as the *Hyperodapedon*-beds of India mentioned by Dr. Blanford.

The PRESIDENT said, the difficulty about the position of the Elgin beds was not so great as was often supposed. In the Old Red-Sandstone quarries fish-remains are by no means rare, but in the extensive quarries whence the reptiles have been procured no fishes are found, and recently the reptiliferous beds have been shown to overlie unconformably the Holoptychian beds. The whole of the strata are greatly faulted and covered with drift. *Hyperodapedon* and *Dicynodon* certainly occurred together, and the specimens of the latter were being worked out by Dr. Traquair. The Rhætic fossils obtained by Mr. Charles Moore were from a boulder.

Prof. HUXLEY, in reply, said he remembered the time when palæontological papers were not received with such general consent. He begged leave to thank the President and Fellows for the very cordial reception they had given him. He was unable to agree with Dr. Baur's views as to the classification of lizards and their allies, and considered that it was undesirable to multiply great groups too much. The Rhynchocephalian forms did not appear to him to have any real affinity with *Simœdosaurus*, nor were they so much generalized as, for instance, *Telerpeton*. Probably in Carboniferous times the gap between Labyrinthodonts and Lizards was bridged over, and intermediate forms occurred.

48. NOTE on some DINOSAURIAN REMAINS in the Collection of A. LEEDS, Esq., of Eyebury, Northamptonshire. By J. W. HULKE, Esq. (Read June 23, 1887.)

IN a short visit which I made with Dr. Woodward in May 1886 to Eyebury to see the very rich and highly instructive collection of Saurian fossils made by Mr. A. Leeds from the Kimmeridge Clay of Northamptonshire, two series of remains arrested our attention by the close resemblances they bore to those of the Wealden *Ornithopsis*, H. G. Seeley, to *Omosaurus*, R. Owen, and to certain of the American Jurassic Dinosaurs described and figured by Prof. O. C. Marsh. We had not at that time with us on the spot the materials for instituting an exhaustive comparison, but on a second visit to Eyebury, recently made, I took with me Sir R. Owen's and Prof. O. C. Marsh's memoirs, and with these by me I re-examined the two series of fossils. The results of this renewed inquiry are so interesting that I venture to bring them under the notice of the Geological Society.

Part I.—ORNITHOPSIS LEEDSII.

ORNITHOPSIS, H. G. Seeley.

Synonyms: *Eucamerotus*, Hulke; *Cetiosaurus*, R. Owen, partim; *Cetiosaurus*, Phillips, partim; *Chondrosteosaurus*, R. Owen, partim; *Bothrospondylus*, R. Owen, partim.

The remains in Mr. Leeds's collection referable to this Dinosaur, or to a very nearly allied form, comprise several vertebræ, ribs, both pubes, both ischia, the right ilium, and many small fragments too imperfect for reunion and identification.

Vertebræ.—All the vertebræ are, I think, referable to the trunk; they comprise four centra, and some portions of neural arches and processes. All the centra are much crushed and distorted, and they have lost their arches. They display the large chambers opening externally in the lateral aspect of the centrum, and excavating this latter so deeply that the chambers of opposite sides nearly meet in the median antero-posterior plane of the centrum under the neural canal, being separated there only by a thin, bony partition, remains of which are preserved in one specimen. The following measurements will give some idea of the bulk of the least mutilated of four centra; but it should be borne in mind that these very imperfectly represent the dimensions of its true figure. The present horizontal diameters of the two articular faces are 29 centim. and 28·5 centim. The same diameter taken at the middle of the centrum is 19·5 centim. The length of the centrum between the two articular faces, taken at the under surface, is 14 centim. This surface is much incurved in the longitudinal direction, which gives the centrum the appearance of being strongly constricted at its middle. I think it probable that some degree of constriction

originally existed, but that this has been greatly exaggerated by compression since death.

Ribs.—A nearly complete vertebral rib, being about three times as large as the longest rib in the articulated skeleton of an Elephant of average stature preserved in the Museum of the Royal College of Surgeons, gives an idea of the great girth of the thorax in this Dinosaur. This rib presents a distinct neck and shaft, which include between them a present angle of about 90° . The vertebral end of the rib is unforked; the capitular and the tubercular articulations were therefore both seated above the level of the neuro-central suture on the transverse process of the corresponding vertebra. In extant Crocodilians this arrangement obtains first at the 11th or 12th vertebra, and this rib is usually the third in that segment of the vertebral-costal series in which the vertebral ribs are connected with the thoracic sternum by sterno-costal cartilages. So far, therefore, as the Crocodilian analogy warrants the inference, this Dinosaurian rib belonged to the scapular region of the thorax. The length of the neck of the rib, taken from its capitular end to the angle which it includes with the shaft, measures 34·5 centim., and that of the shaft, which has a slightly *f*-shaped double curve, taken along a straight line between its extreme points, is 152 centim. The upper border of the neck is approximately straight, while the lower border makes a regular downward curve, and this part of the rib rapidly expands in its vertical dimensions, attaining a maximum measurement of 20 centim. across the angle. From here the breadth declines, becoming only 9·7 centim. at the distance of 41 centim. from the angle. This reduced breadth continues with little variation for a considerable distance, and then augments towards the ventral end, where it is 13 centim. The expanded part of the neck and angle of the rib is a relatively angularly folded plate, exhibiting in its posterior or visceral aspect a deep, longitudinal hollow. The outer surface exhibits the commencement of a longitudinal ridge which subdivides this surface into a posterior part somewhat convex transversely, and an anterior part slightly hollowed. The part of the rib behind the ridge is stouter than that in front of it. In its vertebral third the cross-section of the shaft of the rib is a triquetrous figure; beyond this the shaft becomes flattened as its breadth increases towards its ventral end.

Pelvis.—The ilium, ischium, and the pubis all contributed to the composition of the acetabulum, the last-mentioned bone not being excluded from it as in Crocodilians. The pubis and the ischium diverge, the former being directed *forwards*, downwards and inwards, the latter *backwards*, downwards and inwards; the pubis also is not divided into a præ- and a post-pubic segment: in both these respects this pelvis differs from that of the Iguanodontidæ. One *ilium* only, and this in a very mutilated state, was obtained: I regard it as the right. Its present length is 84·5 centim. Of this the chord of the acetabulum is about 40 centim. long, and the length of the præacetabular portion 45 centim. The maximum breadth of the acetabular surface is 17·5 centim. between its inner and its

outer borders. The præacetabular portion of the bone is narrow relatively to its length, its depth, or width, near the middle measuring about 15·5 centim. Its borders through a great part of its length are roughly parallel. The sacral aspect of the bone is rough and much damaged. Attached to it are projecting fragments, which may be parts of the iliac extensions of sacral costoids. The

Fig. 1.—*Pelvis of Ornithopsis Leedsii, from the Kimmeridge Clay of Northamptonshire. About one-twentieth natural size.*

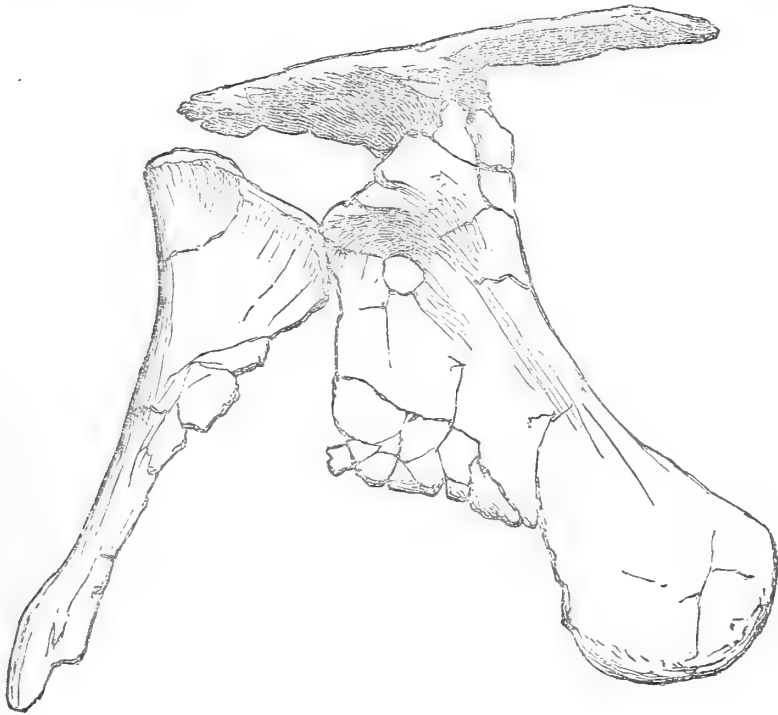

pubis has the form of an expanded, oblong plate, wider and stouter at its ends than at its middle. Its iliac end contributed about $\frac{1}{3}$ to the circle of the acetabulum. The roughness of its curved ventral end suggests the former presence of a cartilaginous lip for symphyseal union with its fellow of the opposite side. The anterior border is incurved. The posterior border for the space of 40 centim. is straight, and throughout this extent was connected with the corresponding border of the ischium, the suture, when the bones are articulated, lying in a nearly vertical plane transverse to the axis of the trunk. From the lower end of the ischial suture the posterior border of the pubis changes abruptly its direction, tending forwards for a space of about 38 centim. This part has sustained some mutilation, so that its extent is not shown; but a small part of the natural margin is preserved near the symphyseal end, and this suggests that the missing part was incurved. The outer surface of the bone, in its upper part, is sinuous in a direction transverse to the long axis, being gently concave behind and convex in front of the axis. The length of the bone from the acetabular part to its symphyseal end is 95 centim., the width of its symphyseal end 40·5 centim., that of the acetabular end is approximately estimated at 40 centim., and that at

the lower end of the pubo-ischial suture is 50 centim. An oval foramen, 6·0 and 6·5 centim. in its two diameters, pierces the bone at a spot not far from the acetabular and ischiatic borders, and 31 centim. distant from its anterior border.

The *ischium* is a much narrower, less expanded bone than the pubis. Its long axis appears as if twisted, the outer surface in the upper part looking outwards and in the lower part of its extent having also a backward inclination. Its length is 91 centim., the breadth at its upper end, taken between the posterior angle of its iliac suture and the lowest point of its pubic suture, is 35 centim. Below this the figure rapidly contracts, so that at the middle of the bone the width is only 15·5 centim., and this continues till towards the lower end, where it enlarges to 17 centim.

The resemblances which these remains—I refer particularly to the pelvic bones—present to those of the Wealden *Ornithopsis* are so obvious as not to admit of any doubt respecting the very near affinity of these two Dinosaurs, if, indeed, they are not actually identical. The chief differences observable, the much larger size and the massiveness of the Kimmeridgian form, are of a kind which may merely express the greater age of this individual, and they do not indicate generic distinctness. Pending, therefore, the acquisition of new materials which, permitting the extension of the comparison to other parts of the skeleton, will furnish a decisive solution of the question of affinity or identity, it appears to me preferable to include the Kimmeridge Dinosaur in the genus *Ornithopsis* than to make a new genus for it. I propose for it the specific name *Leedsii*, in recognition of the liberality with which Mr. A. Leeds affords to scientific inquirers the opportunity of studying his valuable collection; and I am happy to express here my personal obligation to him and Mr. Ch. Leeds for much valuable assistance kindly rendered in the course of my inquiry.

In a former communication to this Society I expressed my conviction of the very near affinity of *Cetiosaurus oxoniensis* and *Ornithopsis**. This was based chiefly on their vertebral resemblances; for the ischium and pubis of the latter were then unknown. But the similarity is not less striking between their pelves, as will become evident upon a comparison of the figure of the inferior pelvic elements of *Ornithopsis* in pl. xiv. vol. xxxviii. of the 'Quarterly Journal' of our Society with the diagram at p. 277 in Phillips's 'Geology of Oxford' (London, 1871); only, because the bones are represented misplaced, each figure in this diagram must be turned over, the margins of the pubis and ischium in proximity to which the measurements 1, 2 occur should be removed from these numerals, and the roughened borders near the word "*ilium*" should be joined vertically below the letter "*a*." When this very excusable error has been rectified, the resemblances of the two pairs of pelvic elements are very significant.

* Quart. Journ. Geol. Soc. vol. xxviii. p. 36, vol. xxxv. p. 757, vol. xxxviii. p. 374.

Of the taxonomic position of *Ornithopsis* in the Order Dinosauria there cannot be any doubt. Accepting Prof. O. C. Marsh's classification as best representing our present knowledge of the order, *Ornithopsis* certainly falls into the group Sauropoda, and should find its place amongst the members of the Atlantosauridæ.

Part II.

OMOSAURUS.

The remains which in May 1886 were thought by Dr. Woodward and myself to be referable to *Omosaurus*, a Dinosaurian genus of which the type specimen, from the Kimmeridge Clay of Swindon, is preserved in the British Museum, comprise a sacrum with both ilia, a caudal vertebra, parts of the other vertebral centra, a femur, a metapodial bone, and many small and indeterminate fragments.

Pelvis.—The *sacrum*, still retaining its connexion with the ilia, is mutilated, and it has been flattened and otherwise disturbed by

Fig. 2.—*Pelvis* of *Omosaurus durobrivensis*, *Hulke*, from the *Kimmeridge Clay of Northamptonshire*. One-tenth natural size.

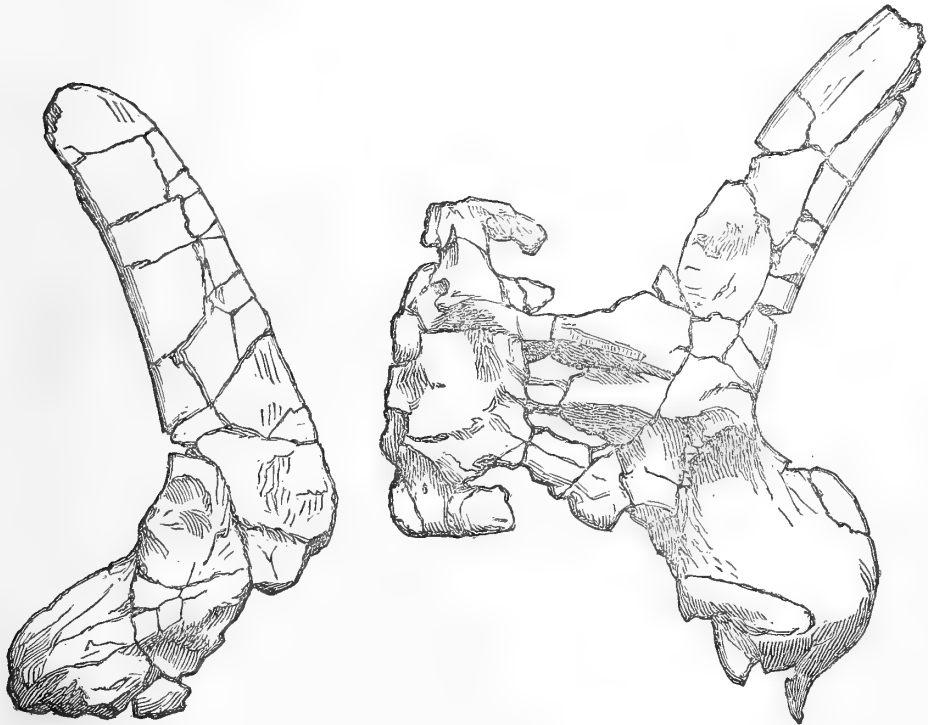

pressure, which has overthrown and squeezed down the spinous processes upon the right transverse processes, hiding the junction of these with the neural arches. The centra of the vertebræ have disappeared, so that in a ventral view the under or neural surface of the neural arches is seen. The arches appear synostosed, thus forming a continuous vault in which the original distinctness of its several segments is doubtfully traceable, a structural arrangement architect-

urally imitating the roof of a brain-case. The spaciousness of this sacral expansion of the neural canal may be inferred from the dimensions of the best-preserved part of the roof, which are 16·5 centim. longitudinally, and 8 centim. transversely. The transverse processes of the sacral vertebræ are long, the second on the left side measures 24·3 centim. ; their vertical extent was considerable, their fractured and mutilated lower border suggests their downward extension below the neuro-central suture upon the lateral aspect of the centrum. The number of sacral vertebræ, inferred from that of the transverse processes prolonged to the ilium, is four. Two in front of these I am inclined to regard as lumbar, from the different direction and length of the transverse processes.

Iliæ.—The ilium is remarkable for the great length of the præacetabular process ; that of the left ilium (the better preserved) is 53 centim., the present entire length of the bone being 85·5 centim. The breadth of the process taken just in front of the acetabulum is 18 centim., and at the distance of 15 centim. from its free anterior extremity it is 15 centim. ; thus the borders of the process are almost parallel. The acetabulum is capacious, the length of its chord is 24·7 centim. The part lying above the acetabulum presents a stout crest, which now projects externally beyond the outer lip of this cavity, but which probably, before the bone was distorted by pressure, was more erect. The longitudinal outline of this crest ascends forwards in a convex curve from the posterior extremity of the ilium to above the middle of the acetabulum ; in front of this it descends, becoming concave, and is lost upon the præacetabular process.

Vertebræ.—A caudal vertebra, well preserved, closely reproduces in its general features those of *Omosaurus armatus*. The total height of this vertebra from the apex of its spinous process to the lowest part of the posterior articular surface is 38·1 centim. ; the height of the spinous process and arch is 26·5 centim. ; the vertical diameter of the anterior articular face is 11·2 centim., and the transverse horizontal diameter 9·2 centim., the same diameters of the posterior articular surface being 12·6 and 11·2 centim. ; and the antero-posterior dimension or length of the centrum is 6·8 centim. Thus the spinous process is lofty, the contour of the articular surface is nearly circular, the vertical dimension slightly preponderating. The figure of these surfaces is gently concave, the depression of the posterior slightly exceeding that of the anterior surface. The right transverse process, nearly entire, has the figure of a triangular vertical plate. Its lower border is directed nearly horizontally outwards, its upper border descends, its base, borne chiefly by the centrum, ascends above the neuro-central suture upon the side of the arch. The free end of the process, swollen and obliquely cut, exhibits appearances which suggest its having borne a rib, as occurs in a few anterior caudal vertebræ of some existing Lizards. The depth of the transverse process near its base is 14·8 centim., its length is 9·4 centim. Below the transverse process the surface of the lateral aspect of the centrum is depressed, being concave longitudinally and vertically.

Two other very imperfect vertebral centra have a slightly con-

stricted cylindroid form with plane or gently concave articular ends. The presence of a large internal space now filled with clay points to the persistence of an intracentral, nodal swelling of the notochord. I refer these vertebral centra to the lumbar region.

Femur.—This bone (the left) is in excellent preservation, though somewhat flattened by pressure. In its straightness, and scarcely observable axial twist, it closely repeats the femur in the type of *Omosaurus armatus*. Its proximal end bears a well-marked oval articular caput separated by a shallow depression from a massive external trochanter lying at the same level, and not divided from the shaft by the deep narrow cleft which is so marked a feature in the *Iguanodontidæ*. The distal end of the bone exhibits the common condylar division; the inner condyle is rather more prominent anteriorly, the outer condyle broader. The dorsal or extensor surface is traversed longitudinally by a depression, wide and shallow in its proximal part, narrower at the middle of the shaft, and deeper and wider distally, where it runs out between the condyles. A low, narrow, but perfectly distinct, crest-like inner trochanter is present at the inner border of the bone, at the middle of the shaft. The posterior intercondyloid groove is deep and wide. The length of this femur is 100 centim., the breadth of the proximal end is 28 centim., that of the distal end 27 centim., and that of the middle of the shaft at the level of the inner trochanter 13 centim.; the diameters of the caput femoris are 12·5 centim. and 14·5 centim.

Metapodium.—A bone which I refer to the metatarsus, from its likeness to the metatarsals of *Stegosaurus* (all the component bones of the foot of which are figured by Prof. O. C. Marsh), is 14·5 centim. long. Its shaft has a cylindroid figure flattened at one side. Its middle is gently constricted, and its ends expanded. The contour of the proximal end is a roughly quadrilateral figure, in which the side answering to the flattened sides of the shaft is straight, the opposite side being convex. The distal end is unequally subdivided into two condyles, the larger of which is prolonged much further on the plantar aspect than is the other. This longer condyle coincides with the convex border of the shaft and similarly convex aspect of the proximal end. I am disposed to refer this bone to the outer side of the left foot.

The correspondence of these remains with those of *Omosaurus armatus*, R. Owen, is so close that I cannot hesitate to refer to this genus the Dinosaur which they represent. The chief differences, the less massive forms of the bones and the hollowness of the vertebral centra, may only express differences of age. In these points and also in the more narrow and elongated form of the præacetabular process there is a closer approach to *Stegosaurus* O. C. Marsh, between which and *Omosaurus*, the very closest affinity exists. For this new species I propose the distinctive name of *Omosaurus durobrivensis*, from the name of a Roman settlement near the present site of Peterborough.

Dermal Armour.—All the remains just described were associated, affording a strong presumption of their having all been parts of one

individual; their general facies, also, and the character of the osseous tissues leave no doubt on my mind that they are parts of one skeleton. From the same locality Mr. A. Leeds has also obtained many fragments of large, thin, flat, bony plates, which cannot be referred to any part of the endoskeleton and which doubtless represent a dermal armour. Two of these shields, which have been reconstructed by accurately placing together their fragments, show that their original dimensions were very considerable, the present breadth of one being not less than 50 centim., and that of another about 80 centim. It has not yet been possible to reconstruct them so completely as to show their original contour. They are formed of two thin tables with an intermediate diploë. The free surface of one table is smooth and mostly of finer grain than the other, which is usually impressed by long pits and furrows, and these, as also the finer grain of the bone, show a radial arrangement starting from the stoutest part of the plate, which rises as a low hummock above the general level of that which I regard as the upper or outer surface. This, which presumably represents the centre of ossification of the plate, imparts a stoutness in one plate of 3 centim., thinning out towards the periphery to less than the thickness of a playing-card. Perhaps this has been reduced by pressure. A few fragments preserve a natural edge; this has the form of a slightly swollen lip, bounded towards the expansion of the plate by a submarginal groove, a construction which suggests that adjoining plates may have been linked together by intercalated flexible integument.

The evident close affinity between *Omosaurus* and *Stegosaurus* made it very probable that as the former possessed dermal spines it would likewise be provided with tegumental plates; I am therefore disposed to associate with the other skeletal remains the plates in Mr. Leeds's collection. Should this association be confirmed by new discoveries, the question may arise, Does not the association rather suggest that the remains should with greater justice be referred to *Stegosaurus* than to *Omosaurus*?

The Dinosaur they represent has, however, in its femur a distinct inner trochanter; this also is present in the type of *Omosaurus armatus*; while it is stated that there is no evidence of its presence in *Stegosaurus*. Should this difference be confirmed, it appears decisive against the generic identity of these two Dinosaurs; but for the moment reservation is necessary upon this subject.

Up to the present time the reptilian fauna of the Kimmeridge Clay has been chiefly distinguished by the abundance of *Ichthyopterygia* and *Sauropterygia*, for the numbers of its *Ichthyosauri*, its *Plesiosauri*, and its *Pliosauri* in their many and distinctive modifications, not less than for the numbers of its Crocodilians, the *Teleosauri* and *Steneosauri*.

Evidence is now accumulating that the Dinosaurian group was also well represented, and this not by one but by several of its subgroups:— (a) The Ornithopoda by *Iguanodon Prestwichii*; (b) the Sauropoda by *Ornithopsis* or a nearly allied form; (c) the Stegosauria by *Omosaurus armatus* and *Omosaurus durobriensis*.

49. *On some NEW FEATURES in PELANECHINUS CORALLINUS.* By T. T. GROOM, Esq., of St. John's College, Cambridge. (Read June 23, 1887.).

[Communicated by Prof. T. M^cK. HUGHES, F.G.S.]

[PLATE XXVIII.]

IN vol. xxxiv. p. 924, of the 'Quarterly Journal of the Geological Society,' Mr. Walter Keeping, F.G.S., described two specimens of a form previously referred by Dr. Wright to the genus *Hemipedina*. He showed that this form was quite distinct from *Hemipedina*, and gave it the name of *Pelanechinus*. It showed, in his opinion, affinities with the Echinothuridæ on the one hand and the Diadematidæ on the other.

These two specimens have hitherto been the only ones known, with the exception of a few fragments described by Dr. Wright.

I was fortunate enough to find in 1881 in the Coral Rag at Calne, in a quarry at the north end of the town, a third specimen which shows some interesting features hitherto undescribed.

The diameter of the test is about 85 millim.; it is considerably flattened from above downwards. The whole of the oral surface is beautifully preserved, with the exception of a sector including one ambulacral and the greater part of two interambulacral areas. The teeth are exposed *in situ*, together with most of the peristomial imbricating plates; the latter, however, are not exhibited so clearly as in the specimen in the Woodwardian Museum. A zone, about 15 millim. wide, belonging to the oral surface is also preserved. My specimen quite confirms Mr. Keeping's opinion that the test was flexible.

The plates have frequently separated along the line of suture, especially on the aboral surface, while the median interambulacral line and the lines of junction between the ambulacral and interambulacral areas have frequently broadened into gaping fissures; the calcareous matter between the plates must either have been deficient or wanting; the plates themselves are occasionally bent, but very seldom broken.

The Interambulacral Areas (fig. 1) differ considerably on the under and upper sides of the test. At the equator there are two large median tubercles to each plate, and two smaller lateral ones; towards the mouth all these decrease regularly in size, and at a little distance from the peristome diminish first to three, and then to two on a plate, the two innermost rows (*i. e.* nearest the median interambulacral line) disappearing first, while the outermost of the large tubercles are the only ones that are represented on the last plates. Above the equator a similar diminution in size takes place in three of the rows; the innermost row of large tubercles almost immediately disappears, as also does the outermost row of the smaller tubercles. The outer row of large tubercles retain almost their full size.

The plates are widest at the equator, but regularly increase in height from the peristome up to the highest point seen.

Thus on the *under* surface we have elongated plates with several tubercles, while on the *upper* surface the plates are deep, bearing one

Fig. 1.—*Portion of an Interambulacral Area of Pelanechinus corallinus.* × 2.

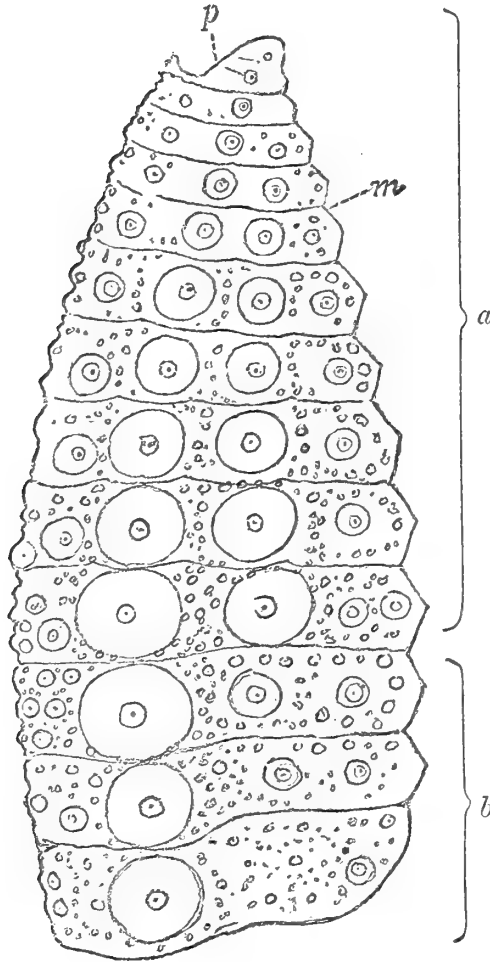

- a.* Plates on oral surface. *m.* Median interambulacral line.
b. Plates on aboral surface. *p.* Peristomial notch.

primary tubercle, the greater part being covered with minute tubercles and granulations.

The plates end abruptly at the peristome in a rounded prominence separated from the ambulacra by moderately deep peristomial notches.

The plates on the aboral side of the test seem to have been free and movable upon one another, as they have commonly separated along the lines of suture, and the sutures are seen at the equator to be the expressions of clean vertical cuts whose edges are often somewhat smoothed off, while the uppermost plates have their borders well rounded. This, I believe, explains the fact that the apical portion of the test is wanting in all specimens hitherto found, though the rest is so well preserved. The shape and disposition of the interambulacral plates undergo a remarkable change on the upper

side of the test immediately after the equator is passed. Their boundaries, before only slightly and regularly undulating, here become distinctly curved, while their inner extremities become much less in width than their outer; the result is that a triangular depression (fig. 6) is left in the interambulacral areas, giving the apical area a pentagonal outline. The uppermost plates at the same time overlap from below upwards; this may, however, be due to pressure, but I believe is natural, as a certain amount of bevelling off at the edges is perceptible.

It is noteworthy that the direction of overlap differs from that of the Echinothuridæ, but is the same as in *Astropyga* *. This genus it also resembles in the behaviour of the interambulacra on the aboral side of the test, the plates undergoing precisely similar changes in shape and disposition †.

The triangular depressions I believe to be due to the projection of the genital plates, which were probably large; the pentagonal outline of the central space probably represents the shape of the apical disk, which must have been of considerable size.

This view is confirmed by the behaviour of the ambulacra, which narrow rapidly on the upper side of the test (fig. 5), and show characters which indicate that they are not far from their apical termination (fig. 4, b).

In their elongated shape, general appearance and behaviour, and in their loose connexion, the interambulacral plates resemble those of the Echinothuridæ and *Astropyga*, the upper plates especially (see figs. of *Asthenosoma* and *Phormosoma* ‡).

In the notched peristome, and the contrast between the plates of the corona and peristome, and between the ambulacral and interambulacral areas, the test resembles that of Echinidæ and Diadematidæ.

The Ambulacral Areas (figs. 2 & 3) were not correctly described by Keeping §. The structure of the plates is best shown at the equator. Each plate is pentagonal and has nine pairs of pores disposed in three oblique rows, each pair surrounded by a peripodium. It is traversed by two sutures, which extend from margin to margin, and indicate the boundaries of the three primary plates which enter into its composition; each of these primaries bears a tubercle and has at its outer border a pair of pores. The middle primary is the largest and supports the largest tubercle; its inner border occupies by far the greater part of the boundary formed by the median ambulacral line; the aboral primary comes next in size, while the adoral is smallest and bears the smallest tubercle. In addition to the three primaries there are six demiplates, which do not extend from margin to margin; each bears ordinarily a pair of pores. The grouping of these component plates is seen in fig. 2. The adoral

* Wyville Thomson, "On the Echinoidea of the 'Porcupine' Deep-sea Dredging Expedition" (Phil. Trans. Royal Soc. vol. 164, part 2, p. 732).

† I am indebted to Prof. Jeffrey Bell for an opportunity of examining this and other genera in the British Museum.

‡ 'Challenger' Report; Echinoidea, Al. Agassiz; and Wyville Thomson, Phil. Trans. Royal Soc. 1874, pl. lxxv.

§ W. Keeping, *loc. cit.*

boundary of the compound plates is occupied by a primary; then come two demiplates, the pores of which form with those of the primary one of the three oblique rows. The largest primary succeeded

Fig. 2.—*Two Ambulacral Plates from the Equator of Pelanechinus corallinus.* $\times 4$.

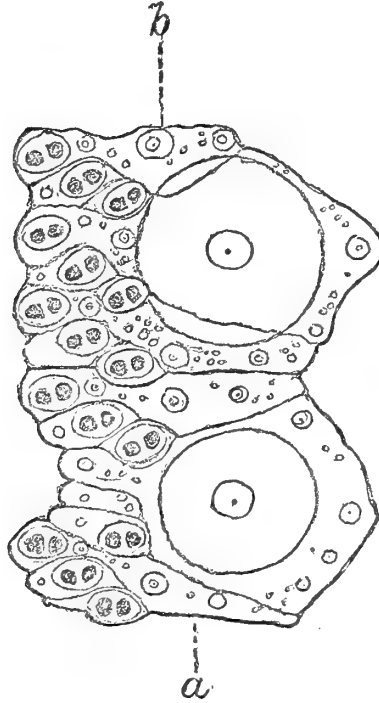

a, aboral; *b*, adoral boundary.

Fig. 3.—*Ambulacral Plates from above the Equator of Pelanechinus corallinus.* $\times 4$.

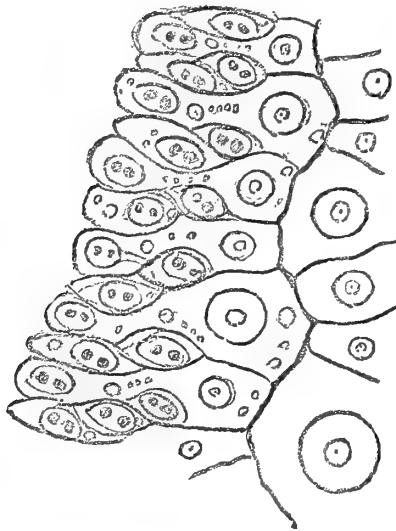

by two demiplates forms the second oblique row, while the aboral primary with two demiplates forms the third. At one place (fig. 2) where some of the pores are aborted, the boundaries of the demi-

plates are seen very distinctly. The primaries can readily be traced across by means of the granulations and tubercles covering them. The sutures traverse the base of the large tubercle, which thus rises from all three primaries.

I have described the structure of these plates at length because I believe the type to be a new one. It does not seem to be included under any of the six types given by Prof. Duncan, in his paper on the ambulacra of fossil Echinoidea*. Of these six the only ones it at all resembles are the Echinoid and Diadematoïd; from the former it differs in having primaries in the middle, and from the latter in having demiplates in the middle.

This structure may, however, have arisen from the fusion of three oligoporous plates into one; thus each of the primaries with the two demiplates above would represent an oligoporous plate. Three of these fusing with one another, together with development of the middle one with its tubercle at the expense of the two others, would give us such a polyoporous plate as we have before us.

This phenomenon seems to me quite analogous to the method of formation of the oligoporous plates from three primaries, especially in the case of many Diadematoïd and Arbacioid forms in which the middle plate develops at the expense of the other two. Whilst entertaining this idea, I was much interested to find that towards the apex the association between the primaries seems much less intimate, the sutures being replaced by deep fissures, and the adoral and aboral primaries with their tubercles relatively larger and more independent; in fact I believe that in the uppermost plates seen, where the most primitive condition doubtless prevails, the oligoporous condition actually obtains, though the plates are not quite of the same size.

Traced towards the mouth the structure of the ambulacral areas is precisely the same as at the equator, and the arrangement is still trigeminal. At the peristome the imbricating plates come in suddenly. As the area narrows, the tubercle decreases in size, and the middle primary ceases to project much beyond the others, so that the median ambulacral line running at the equator in sharp S-like curves passes, through less abrupt curves, into a gently undulating line finally terminating in an almost straight portion.

Above the equator the main tubercle again diminishes in size, but much more suddenly, in correspondence with a more sudden narrowing of the areas. As the middle primary diminishes in size, the adoral and aboral primaries maintain theirs, and their tubercles increase rather than diminish in size, so that at the highest point seen the primaries with their tubercles show comparatively little difference (fig. 3). The plates here seem to be in an oligoporous condition, and judging from the diminished width of the areas, the small and nearly uniform size of the tubercles, and the gently undulating median line, the ambulacral areas are near their aboral termination.

The ambulacral plates, then, of *Pelanechinus* may be looked upon as

* Quart. Journ. Geol. Soc. vol. xli. 188

a modification of the oligoporous Echinoid type, in which the two aboral primaries are represented by demiplates*.

They could not, however, arise from the fusion of three of the oligoporous plates of the Echinothuridæ †, where we also meet with a trigeminal arrangement, as there the demiplates seem to be adorally placed.

The ambulacral areas seem at first sight to present a considerable amount of resemblance to those of *Astropyga pulvinata* ‡. This form has oligoporous plates, each of which has a tubercle, every third plate being larger than the other two, this giving rise to an S-shaped median line. Prof. Duncan has, however, shown that the triplets are arranged after the type of *Diadema* §.

Fig. 4.—One of the Rows of Imbricating Actinal Plates in *Pelanechinus corallinus*, with the adjacent interambulacral (*i*) and ambulacral (*a*) areas. × 3.

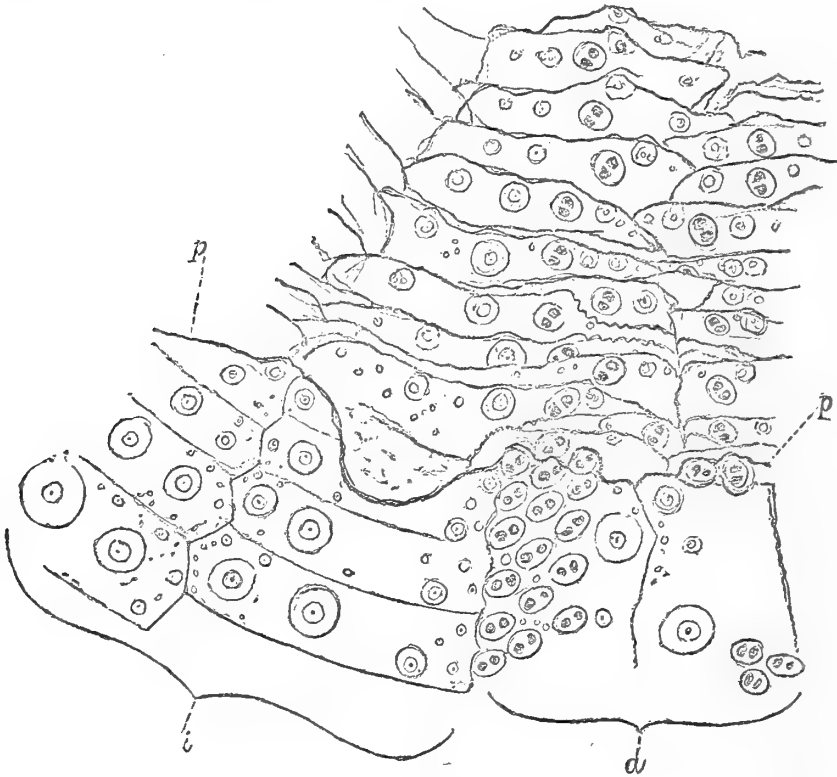

p. Peristome.

The Imbricating Peristomial Plates (fig. 4).—These, in my specimen, are not well shown; but the results of a re-examination of a specimen

* Duncan, *loc. cit.*

† It is usually stated that the plates of the Echinothuridæ are simple primaries, but the figures of Agassiz ('Challenger' Report) make it clear that they are, at any rate in many cases, oligoporous, the demiplates (= the so-called accessory plates) which seem constantly to occur on the adoral side of the primary being distinctly fused with the latter. See figs. in 'Challenger' Report:—*Phormosoma hoplacantha* (pl. xii a. fig. 12), *Asthenosoma tessellata* (pl. xxi a. fig. 14), *Asthenosoma Grubei* (pl. xvii. fig. 6), *Asthenosoma pellucida* (pl. xviii. fig. 5).

‡ Journ. Linn. Soc., Zool. vol. xix. p. 95, pl. v. fig. 9.

§ Duncan, Journ. Linn. Soc., Zool. vol. xix. p. 106.

in the Woodwardian Museum are given in fig. 4. At one place the peristomial plates are beautifully preserved; here a row of at least 13 plates is visible, on each of which (except the most adoral, which is partially hidden) a pair of pores is seen*. These, as Keeping points out, are arranged approximately in a vertical row. Each plate extends from the median ambulacral to the median interambulacral line. This is also seen more or less clearly at other points, both in the Woodwardian and my own specimen. There are thus 10 rows of imbricating plates, and all are perforated by pores. The arrangement thus differs from that in *Cidaris*, where imbricating plates devoid of pores are found opposite the interambulacral area, but is identical with that found in *Asthenosoma Grubei* †, *Phormosoma bursaria* ‡, *Phormosoma luculenta* §, &c. The overlapping plates much resemble those of *Asthenosoma hystrix* || and of *Phormosoma bursaria* ¶ and they imbricate and overlap one another in exactly the same way. The inferior (oral) edge of most of the plates is tolerably straight, but in those nearest the mouth it is raised up into an eminence which supports a member of one of the three rows of tubercles with which these plates are provided.

Pedicellariæ (Pl. XXVIII).—A feature of great interest is the occurrence of the structures known as pedicellariæ. These, which were first made known by O. F. Müller**, and have been variously looked on as parasites, young stages of *Echini*, &c., are now recognized as spines peculiarly modified for prehensile purposes.

They have not hitherto, so far as I have been able to ascertain, been described as occurring in a fossil state. Prof. Zittel remarks in his 'Handbuch der Paläontologie,' vol. i. p. 474:— "*Pedicellariæ* . . . are of no practical significance to the palæontologist, since, on account of their delicate nature and small size, they are not capable of being preserved." I have, however, found them in great variety and abundance, and in beautiful preservation.

Though small, they are distinctly visible to the naked eye. The only satisfactory way to examine them was, I found, to place the whole urchin on the stage of the compound microscope, and use a good illumination. If this method were employed, I believe the pedicellariæ would be found in many other cases also.

The pedicellariæ of *Pelanechinus* are all 3-valved, and their surface shows here and there numerous granulations. I have found three distinct varieties, and of the three kinds into which the pedicellariæ of *Echinus* were divided by Valentin††, whose nomenclature has been generally adopted, I believe two are represented.

* Prof. Zittel, in his 'Handbuch der Paläontologie,' vol. i. p. 504, refers to this form as having, according to Keeping, peristomial plates *devoid of pores*; this, however, is not correct, as Keeping distinctly states that the ambulacral pores are continued over these plates to the mouth. They are also visible in my specimen; but fig. 3 will remove all doubt.

† 'Challenger' Report, Echinoidea, pl. xvii. figs. 1-4.

‡ *Ibid.* pl. x b. fig. 3.

§ *Ibid.* pl. x a. fig. 4.

|| Phil. Trans. Royal Soc. 1874, pl. lxvi. fig. 1.

¶ 'Challenger' Report, Echinoidea, pl. x b. fig. 3.

** Zoologia Danica, 1788, p. 16.

†† Monographie de l'Echinus.

(a) The commonest variety is represented in Pl. XXVIII. fig. 1. The largest seen (fig. 1*d*) measured about 1 millim. in length. In shape they are conical and each consists of three valves which fit neatly and tightly together. I could detect no teeth on them. They vary in size; each valve is broadest at its base, and is furnished with a rounded knob close to the point of attachment. In front it narrows,

Fig. 5.—*Oral Surface of Pelanechinus corallinus (restored).*
Nat. size.

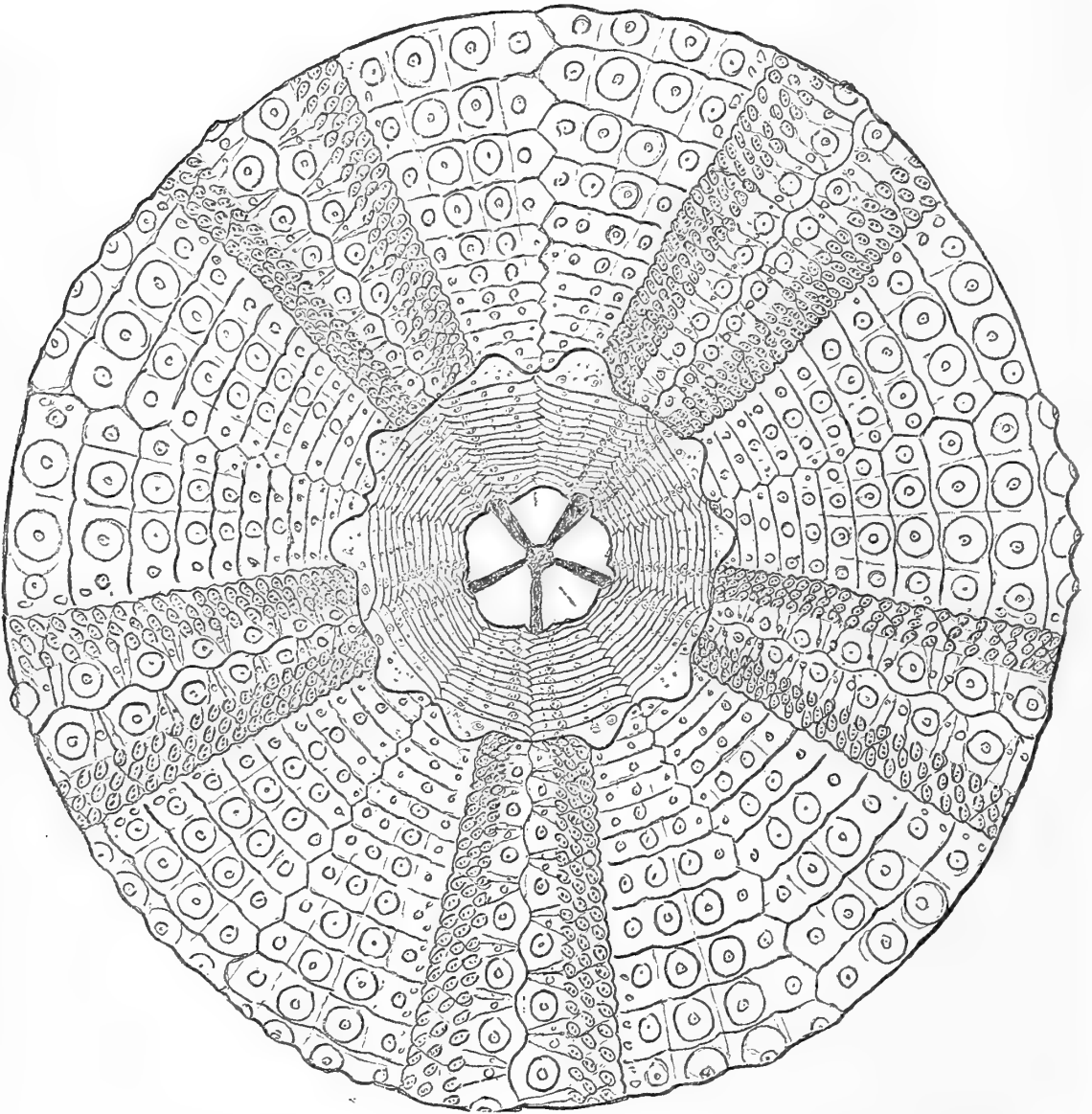

and then expands again to a broad spoon-shaped piece. The interior of the valve is shown in figs. 4*e* and *f**. The lower portion is seen to be divided by a median crest, which in recent pedicellariæ gives attachment to the muscles connecting the valves together†. This variety only occurs in a depression immediately surrounding the imbricating plates. They probably have long stems.

* Fig. 1*f* is very diagrammatic.

† P. Geddes, Trans. Royal Soc. Edinburgh, vol. xxx. part i. p. 383.

(b) On the oral surface of the test, extending to a greater distance from the peristome than the last variety, are found a number of very slender pedicellariæ. These also have three valves; the base is tri-

Fig. 6.—*Half the Aboral Surface of Pelanechinus corallinus.* $\times 1\frac{5}{8}$.

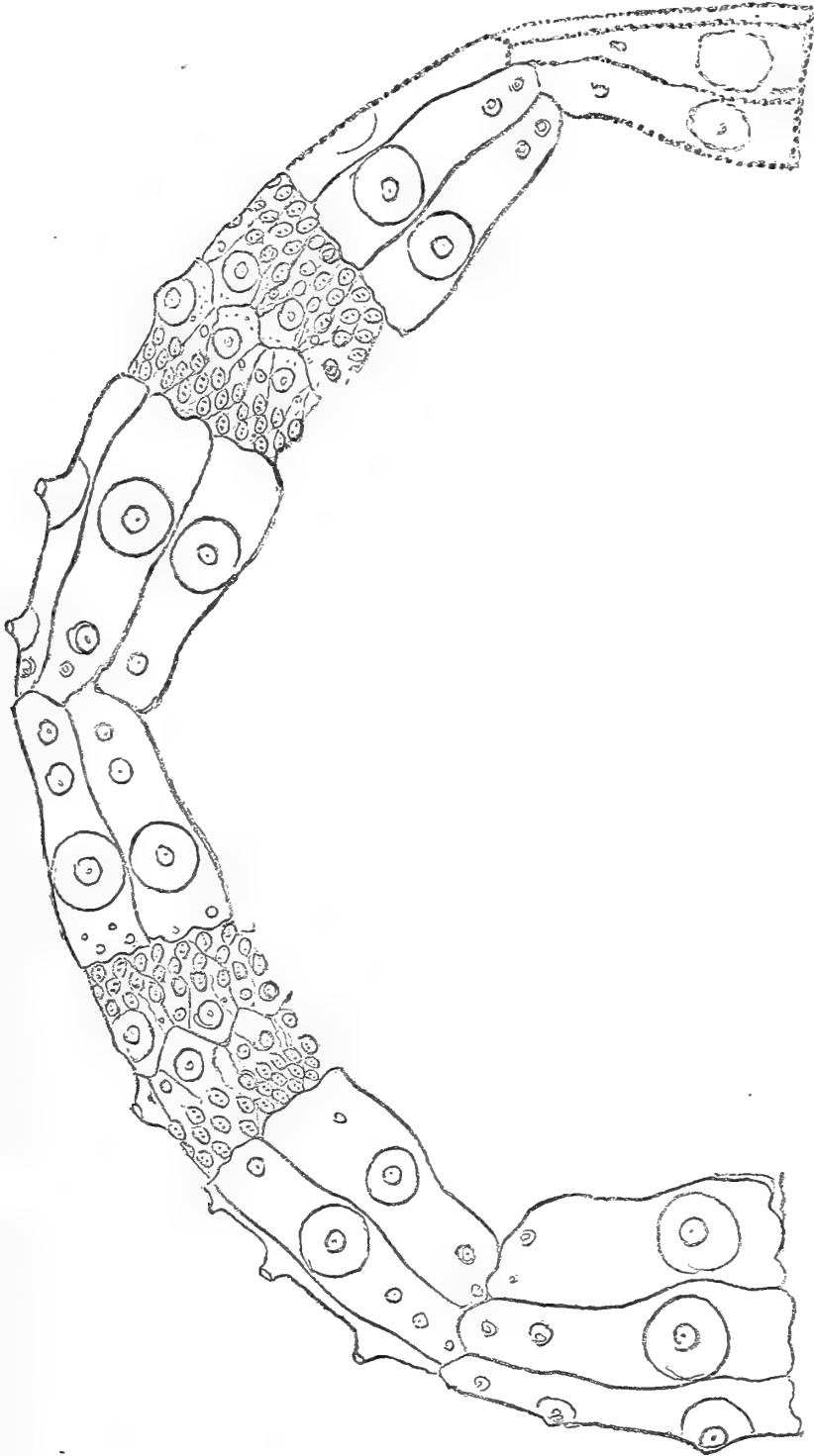

angular and lies nearly at right angles to the long slender prong into which it passes. These may perhaps be referred to the type known as gemmiform (Pl. XXVIII. fig. 2). The one figured measures 1.16 millim. in length. These also probably had long stalks.

(c) Of the third variety only a single specimen occurs, it was found on the upper side of the test, near the middle of an interambulacral area. It is much larger than the others, and measures 2 millim. in length. Each valve has a stout basal portion perforated by a circular foramen. A prong given off from this widens out at the extremity into a spoon-shaped end, the margins of which are supplied with a number of small triangular teeth (Pl. XXVIII. fig. 3 a). This, and the first variety, may be referred to the tridactyle type.

As this pedicellaria became detached from the rest of the specimen, I was enabled to examine it from all points of view. Fig 3 b is a side view, 3 c a view from the basal end, and 3 d a view of the three spatulate prolongations. The circular aperture is distinct only in one of the valves. In general shape this pedicellaria resembles those of *Asthenosoma hystrix* figured by Sir Wyville Thomson*.

I have found pedicellariæ of the varieties a and b on the specimen in the Woodwardian Museum.

Pedicellaria-stems (Pl. XXVIII. figs. 4 a, b, c, d).—Numerous examples of these are scattered about the test. They vary greatly in size, but all agree in having a slender shaft with enlarged extremities; the basal extremity ends abruptly, while the free end to which the pedicellariæ were attached is well rounded. I found none in actual connexion with the pedicellariæ; but they are readily to be distinguished from the spines; they are more slender, and the striations on them are much finer. The rounded ends have no constriction such as is found among the Echinothuridæ and Diadematidæ. The stems more resemble those of the Echinidæ †.

Teeth.—I have lastly to mention the teeth. These were figured and carefully described by Wright, in his 'Monograph of the Oolitic Echinodermata' ‡. Mr. Keeping, when describing *Pelanechinus*, was unable to find the specimen figured by Dr. Wright. In company with Mr. Newton, I succeeded in finding it in the collection of the British Museum. It is undoubtedly referable to our *Pelanechinus corallinus*. The epiphyses were probably not united to form an arch above the teeth.

Affinities and Systematic Position.—Of the distinctness of *Pelanechinus* as a genus there can be no question. While it resembles the Echinothuridæ in the flattened shape, in the flexibility and thinness of the test, in the length, undulating boundaries, shape, and general characters of the interambulacral plates, and above all in the nature and arrangement of the peristomial plates, yet in the contrast between these and the adjacent coronal plates, and between the ambulacral and interambulacral plates, in the notched peristome, and in the types and variety of the pedicellariæ, it is allied to the Glyphostomata of Pomel (Echinidæ and Diadematidæ).

The flexible test with overlapping plates occurs also in *Astropyga*

* Phil. Trans. Royal Soc. vol. 164, pl. lxiv. figs. 4, 5.

† See figure of *Strongylocentrotus* in Al. Agassiz's 'Revision of the Echini,' pl. xxiv. fig. 20.

‡ P. 163, pl. xii. fig. 1 a.

among the Glyphostomata, and this genus *Pelanechinus* resembles in the shape and character of the aboral interambulacral plates.

It seems to have affinities with both members of the Glyphostomata. It resembles the Diadematidæ in the possession of simply grooved teeth, and the Echinidæ in the structure of the ambulacral plates and in the shape of the pedicellaria-stems.

It thus occupies an intermediate position between the Echinothuridæ and the Glyphostomata; and its peculiarities seem to entitle it, if not to a separate position between the two families, at least to the rank of a subfamily (which might be termed Pelanechinidæ) among the Glyphostomata, to which it seems most nearly allied. I may say that this is the position assigned some weeks ago to *Pelanechinus* by Prof. Alex. Agassiz from a cursory examination of my specimen. He expressed an opinion that *Pelanechinus* was allied to the Echinothuridæ on the one hand and the Diadematidæ on the other, the affinity being rather with the Diadematidæ.

CHARACTERS OF *Pelanechinus corallinus*.

Test. Circular, depressed, thin, and probably flexible.

Interambulacral Areas. Narrow at the peristome, broadening rapidly to more than twice the width of the ambulacra at the equator, where there are eight rows of tubercles.

Plates differ on the under and upper sides of the test; on the under surface elongated and with several tubercles; on the upper surface broader and with undulating boundaries, movable and probably overlapping from below upwards. One primary tubercle on each plate.

Ambulacral Areas. Less than half the width of the interambulacra at the equator, narrowing gradually towards the peristome.

Plates towards the apex of the oligoporous *Echinoid* type, with one adoral primary and two aboral demiplates; but at the equator compounded into polyporous plates with nine pairs of pores arranged in three oblique rows, one primary tubercle for each median primary.

Peristome. Large, about $\frac{1}{3}$ of the diameter of the test. Peristomial notches of moderate depth. Peristomial membrane covered with 10 rows of overlapping and imbricating calcified plates with 3 rows of tubercles on their free edges. Each plate with perforated tubercles, spines, granules, and a pair of pores; the successive pairs forming a linear series continuous with the pores of the ambulacra.

Dental Apparatus. Alveoli powerful. Teeth simply grooved.

Apical System. Probably large and pentagonal.

Primary Tubercles. Rather small, perforated, and mounted upon elevated bases, with smooth and uncrenulated summits; they are uniform over both areas.

Spines. Small, hollow, longitudinally striated.

Pedicellariæ. Three kinds (Pl. XXVIII.):—

- (a) Small tridactyle from round the peristome, probably long-stalked (fig. 1).

(b) Gemmiform from the oral surface, probably long-stemmed (fig. 2).

(c) Large tridactyle, spoon-tipped, from the aboral surface (fig. 3).

Pedicellaria-stems. Long, slender, head without constriction (fig. 4).

EXPLANATION OF PLATE XXVIII.

Fig. 1, *a, b, c, d.* Pedicellariæ from round the peristome, $\times 50$. *e.* Internal view of one of the valves, $\times 50$. *f.* Internal view of an older one (diagrammatic), $\times 50$. *g.* Basal view of one, $\times 50$.

2. Slender pedicellaria from oral surface, $\times 50$.

3, *a.* Large tridactyle pedicellaria from aboral surface, seen from above. $\times 40$. *b,* Ditto, seen from the side; *c,* view of basal end; *d,* view of distal end.

4, *a, b, c, d.* Pedicellaria-stalks, $\times 50$.

DISCUSSION.

Prof. DUNCAN said he had recently gone over Mr. Keeping's drawings, and his interpretation of the peristomial plates resembled Mr. Groom's. The imbricating plates are all ambulacral, there being no interradial plates of that nature as in *Cidaris*. The discovery of fossil pedicellariæ was quite new.

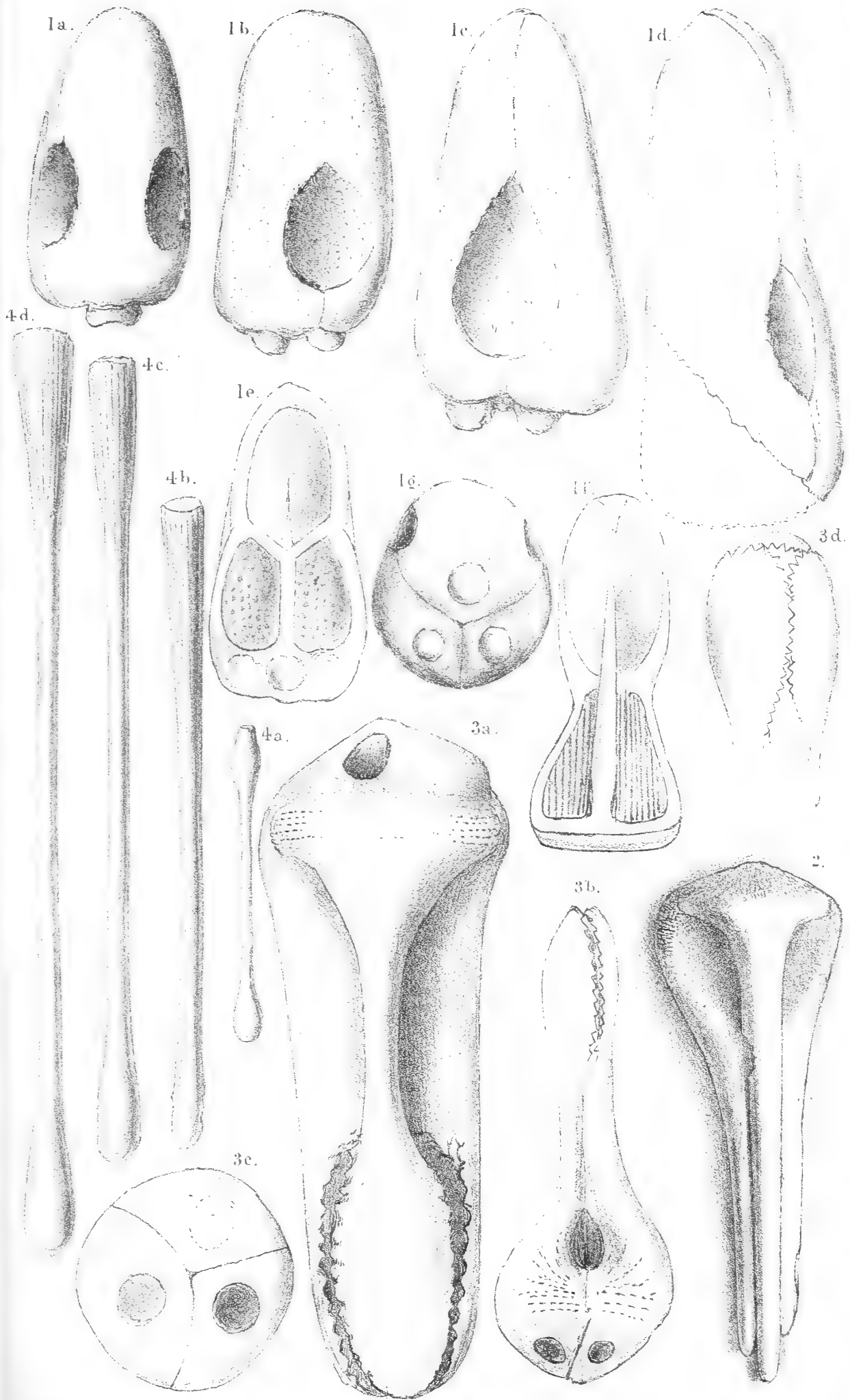

F. H. Michael del. et lith.

Mintern Bros. imp.

PEDICELLARIÆ OF PELANECHINUS.

50. NOTES on the METAMORPHIC ROCKS of SOUTH DEVON.

By CATHERINE A. RAISIN, B.Sc. (Read June 23, 1887.)

(Communicated by Prof. T. G. BONNEY, D.Sc., LL.D., F.R.S., F.G.S.)

CONTENTS.

- | | |
|---|--|
| <p>I. Boundary of Slaty and Metamorphic Series.</p> <ol style="list-style-type: none"> 1. Hope Cove. 2. West of Salcombe Estuary. 3. East of Salcombe Estuary.
Southward of South Pool. 5. Eastward of Estuary; inland, and Hall Sands. <p>II. Microscope Slides and Lithological Characters of Metamorphic Rocks.</p> <p>A. Microscope Slides.</p> <ol style="list-style-type: none"> 1. Chlorite-Schists. 2. Micaceo-chloritic Schists. 3. Mica-Schists. | <p>B. Macroscopic Structures.</p> <ol style="list-style-type: none"> 1. In Mica- and Micaceo-chloritic Schists. Strain-slip cleavage. 2. In Chlorite-Schists. <p>III. Stratigraphical succession in Metamorphic rocks from their northern limit.</p> <ol style="list-style-type: none"> 1. (a) Interbanded Series.
(b) Chlorite-Schist. 2. (a) Mica-Schist.
(b) Interbandings? 3. Mica-Schist.
Estuary south of South Pool.
Eastward of South Pool. <p>IV. Summary.</p> |
|---|--|

THERE are scanty notices, by De la Beche and other earlier writers, of this southernmost part of Devonshire; but later it has been very fully described by Professor Bonney*; and taking his paper as a guide, I was able during two visits to obtain some knowledge of the district. I have ventured to think that a few supplementary details might be of some slight interest.

I. BOUNDARY OF SLATY AND METAMORPHIC SERIES.

As I had not time to visit thoroughly all parts of the district, I tried primarily to make an examination of the exposures in the vicinity of the junction of the slaty and the metamorphic series. Here I was anxious to arrive independently at a conclusion on the question whether metamorphism had affected a continuous series of beds, or whether the southern rocks had the character of a separate and probably much older formation. Hence, before visiting any of the sections already described, I made expeditions to two localities on the shores of the estuary north of Portlemouth, where I found exposures, in one place quite, in the other nearly, continuous from Devonian to metamorphic rocks. I had no real difficulty in deciding when I had passed from one formation to the other, and the opinion then formed as to the complete distinctness of the two series was confirmed by further examination in the field and by the microscope.

Along the southern boundary of the slaty rocks, I visited the cliff exposures of the eastern and western coasts, those bordering the estuary, and I also zigzagged across parts of the intervening country.

1. *Hope Cove*.—The western limit of the boundary line at Hope village is marked on the Survey map, and has been described by

* Quart. Journ. Geol. Soc. vol. xl. p. 1.

Fig. 1.—Map of part of South Devonshire. (Scale 1 inch to 1 1/2 mile.)

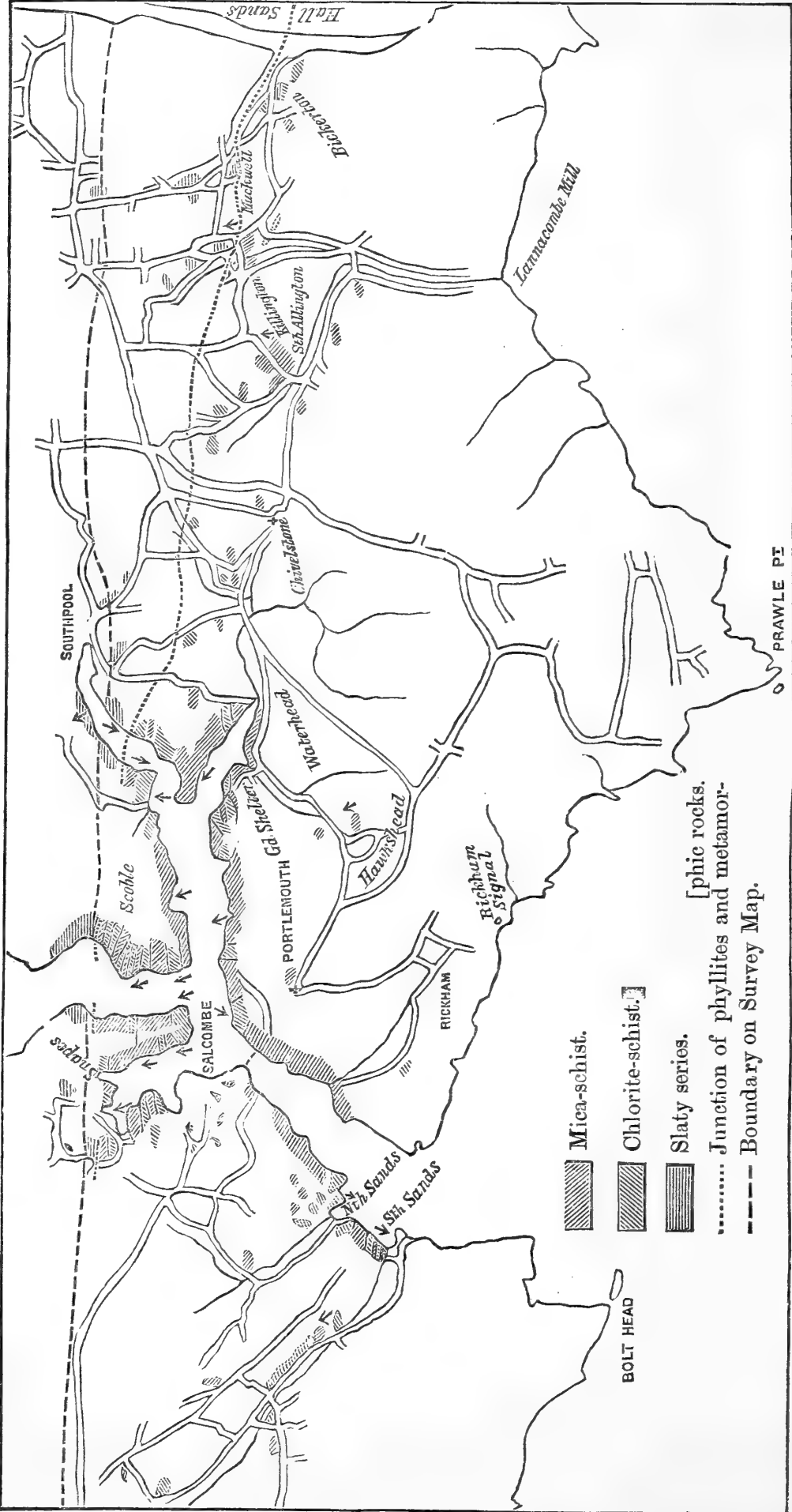

For district to the south, see Prof. Bonney Map, Q. J. G. S. vol. xl. p. 2.

Prof. Bonney, as running out to sea in the cove just north of a small rocky headland. I was able, owing to a more favourable tide, to skirt this headland for a short distance, and found clear evidence that its northern face, as suggested, "has been determined by the fault." While the mass of the headland is of mica-schist, fragments of what are evidently beds of the slaty series are found coating its northernmost portion. They agree with that series in direction and amount of dip; and, lithologically, are very like beds occurring at a junction near South Pool, to be described immediately. They consist chiefly of impure limestone, very much indurated and crystalline in character, and of brittle bands of blackish material having a very crushed and slickensided look. At a higher level, where the scour of the waves between high and low tide would be stronger, the neck of the headland has been worn away rather more deeply, and exposes down its cliff signs of what I believe is the faulted junction.

2. *West of Salcombe Estuary.*—On the western shore of Salcombe estuary, as Prof. Bonney has described, the actual junction is not seen; but we can easily recognize when, from smooth satiny slates dipping evenly to the west of north at about 55° , we have passed, over a very short interval, on to mica-schist. To the west of this exposure, I noted, in a lane north of Batson, the occurrence of phyllites* followed by mica- and chlorite-schists, the junction being rather to the south of the line given on the map, thus agreeing with the position on the estuary suggested by Prof. Bonney.

3. *East of Salcombe Estuary.*—On the opposite shore of the estuary I landed at Halwell Wood, and walked southwards by a low cliff, where the phyllites were well exposed, varying somewhat in character, but all clearly of the unmetamorphosed series, having a dip of about 55° to the west of north. Some bands were fairly good slate, others true phyllite; while here and there the sheen surface, developed along veined or coarser and more gritty parts, gave an irregular schistose look to the beds, which, however, was easily distinguished as a merely superficial likeness. South of the phyllites, a tiny streamlet comes down to the beach, and the mouth of its slight valley extends about 50 yards with no exposures; then mica-schist, at first very brown and decomposed, forms the low cliff.

4. *Southward of South Pool.*—Along the arm of the estuary which comes down from South Pool, we can again note where the junction of the two series occurs, and we find it some 200 yards south of the line drawn on the Ordnance map. The west shore gives us a continuous section, and, in spite of the ferruginous rotting which has attacked some 75 feet of the rocks, I identified, I believe, both the original phyllites, with hard calcareous bands similar to those which I found at Hope Cove, and also the much altered, but more massive, rhomboidally-jointed chlorite-schist, which is here the first of the metamorphic rocks to be met with as we go south. On the east shore there is a blank of about 100 yards (partly occupied by a cliff of recent deposit) which separates the phyllites on the north from

* I use the term phyllite to denote a slate in which a large amount of micro-lithic mica is developed.

chlorite-schist to the south; and over this space several very small springs flow out. The more recent series consists chiefly of satiny slates, greenish or greyish, splitting with the characteristic crisp brittle fracture, here and there with hardened bands of impure limestone, and cut at places by thick white quartz veins; they are occasionally contorted and irregular, but for the most part lie smoothly and evenly. The phyllites of the western shore show a steady dip to the west of north; while the chlorite beds, including micaceous bands, after some variation, set in dipping towards the south. On the eastern bank, the slaty beds dip with some exceptions in a southerly direction but the cliffs are so low, and, in cuttings into the phyllite, I so often noted a tendency for the upper part, even to a depth of four, five or six feet, to be bent over in an opposite direction to the true dip, that I should hesitate to trust the southerly inclination, if there were not a constant, though interrupted, suggestion of it over a space of nearly half a mile.

5. *Eastward of South Pool Estuary.*—At Hall Sands there is at first sight some little difficulty in fixing the boundary of the two series; but on more careful examination, we see that the rocks south of the stream all show schist-like fracturing, and are of very micaceous character, only with something of the look of phyllites, due, I doubt not, to subsequent slickensiding or crushing. To the north of the valley the slaty beds have, it is true, a very thorough development of micaceous surface, and, at places, a wavy lamination, which gives a superficially schistose character, especially when accompanied by corrugations and irregular veinings of quartz; but these beds are soon interrupted by evenly cleaved true slaty bands. My note made on the spot, after re-examination, was, that “any simulations of phyllite, south of Hall Sands, and any simulations of schist, north of Hall Sands, are in each case local and very inextensive; a small flake of the southern cliffs might be mistaken for phyllite, and a veined fragment of the northern rocks might be thought approximating to schist, but any larger examination, even in the field, would show the distinctness.” This conclusion, on referring to Prof. Bonney’s paper, I found to be in complete agreement with his own summary of the difficulty.

I walked through most of the lanes lying between South Pool and Hall Sands, and found no difficulty in deciding whether an outcrop was of slaty or of metamorphic rock. Over much of the country the rocks are hidden, but deep cuttings by roadsides and occasional quarries enabled me to decide that the line of fault, traced eastwards, bends rather to the south, running out to the sea at Hall Sands, as marked on Prof. Bonney’s map. The boundary runs between the South Pool and Chivelstone valleys, along the summit, or the northern slope, of the rising country; its line is not exactly defined, but I rather incline to mark it somewhere along the more southerly of its possible positions. Eastwards, to the south of Ford, I found some indications, which suggest the continuation of the fault south of the main road. Very good exposures mark its position as passing through Killington, to the south of Muckwell, and as having determined the lower part of the course of the Hall-Sands streamlet.

South of this valley, the most northerly of the metamorphic rocks are of chlorite-schist, including micaceous bands. This chlorite rock forms the foundation of some of the Bickerton cottages; it has been worked at one small quarry south of the Bickerton lane, and at another on the hillside overlooking Hall Sands, and is of an ordinary, but very well-banded character.

We have thus roughly traced the southern boundary of the phyllites, and this boundary cuts obliquely across the general strike of the metamorphic beds, so that different members of this series are thrust against the phyllites as we go eastwards. There is, at places, marked variation of dip and strike, and the beds, as I shall describe later, are often disturbed, and dip, in some cases, at a very high angle. Wherever an actual junction is exposed, it emphasizes itself by decomposition of the rocks into a brown iron-stained material. More often the beds thus affected have been completely denuded, and their former place is marked by a small valley or streamlet.

II. MICROSCOPE SLIDES AND LITHOLOGICAL CHARACTERS OF THE METAMORPHIC ROCKS.

A. *Microscope Slides.*

I examined slides from various parts of the district, and I may perhaps be allowed to add to the full descriptions, given by Professor Bonney, a few notes on specimens which seem to me not quite of the normal type. The metamorphic rocks, as he has stated, may be grouped into two series, essentially characterized by the abundant presence of mica and of chlorite respectively. I found, however, some specimens containing such an amount of both minerals that I have ventured to speak of them as micaceo-chloritic; but if this term is objected to, they can be placed as exceptional forms, partly of chlorite-schist, mainly of mica-schist. These rocks occur at places where there are alternating beds of chlorite- and of mica-schists, and especially along an extensive tract in the north of the area. It is true that chlorite is present in some of the typical mica-schists; but these differ from the "micaceo-chloritic," even in hand-specimens, and markedly under the microscope; while in the true chlorite-schists, if the colourless mica is found, it occurs generally in only an occasional flake.

1. *Chlorite-Schists.*—When we examine, as our first example, a typical slide of chlorite-schist, we see, without magnifying, irregular bands, greenish in colour, alternating with bands of material apparently quartzose. By the aid of the microscope the separate constituents can be investigated. The green layers consist mainly of a mass of chlorite aggregated in the modes described by Professor Bonney, generally associated with some brown ferruginous deposit, not identifiable, and with epidote. The epidote may appear in numerous small grains, or in larger crystals, some exhibiting cleavage-lines, and showing occasionally a tendency to break up. The chlorite folia are sometimes grouped in a radiate manner; they are generally dichroic, changing from a feeble brownish tint to a deep green colour; by the extinction being parallel to the cleavage-

planes in some examples, the species would seem to be a chlorite of uniaxial character, possibly, in part at least, prochlorite of Dana. The more transparent layers in the chlorite-schist slide are constituted chiefly of grains not usually elongated in form, in some cases adjoining in the manner of quartzite- or schist-grains, but often separated by a pale greenish or dark deposit, composed partly of not clear chlorite, partly of more opaque substance, this intermediate material being often in more or less continuity with the mass of the green chloritic layers. The grains thus defined have an appearance as if they had been forced apart, possibly by local crushing of the rock; and this appearance occurs most markedly in slides from districts where the rocks in the field had a disturbed aspect. Professor Bonney calls attention to a somewhat "clastic look" in specimens examined by him, and suggests its being due to the action of "unequal pressure." The transparent grains themselves are many of them uncleaved and fairly clear, except for minute enclosures, small flakes of chlorite or other belonites; and these grains I suppose to be chiefly quartz. Of others, which show more or less distinct cleavage, some at least, after hesitation, I identified as possibly kyanite, the presence of this mineral being suggested by Professor Bonney in some of the chlorite-schists. In some cases my specimens show, as Rosenbusch describes, an extremely clear appearance, with the occurrence of infiltration-products settled along the very distinct cleavage-planes*. As is stated by Fouqué and Lévy to be the character of thin slices, the grains are colourless and not dichroic †. Felspar seems to be present in certain slides as an occasional grain, and it may occur more markedly in other specimens; but in many cases its appearance is not quite normal, and Professor Bonney has suggested to me the possibility of the crystal consisting of a secondary mineral replacing the original felspar. Such typical characters of chlorite-schist I have noted in slides from rock obtained along the coast northward of Prawle Point, from the cliff near North Sands, and in others to be mentioned immediately.

In a slide cut from the chlorite-schist which is quarried near North Sands, I was interested to find hornblende occurring in portions larger than the belonites described by Professor Bonney. There are in the slide a fair number of specimens varying in size, but all very characteristic; they are green in colour, exhibit dichroism, and have the cleavages parallel to α P well marked. Most of the grains also are partially bounded by prismatic faces. They occur, some of them intercrystallized in nests of quartzose material, others in the greener bands of the rock, where, at parts, they seem to merge into the chlorite, at parts seem as if eaten into by the bordering epidote-grains. In chlorite-schist near Rickham Signal the clastic aspect, previously described, is noticeable, and is emphasized (even more markedly than in my specimen from North-Sands quarry) by the deposition of calcite along cracks in some of the clear mineral. Among the grains may be noted one of a twinned

* Mikr. Phys. der petr. Min. p. 345.

† Min. Micr. p. 460.

crystal, which has evidently been broken and suffered some displacement of its parts with deposition of calcite along the crack. Similar examples of pressure-effects may be found in various slides. Many of the clear grains in this Rickham specimen, even where not exhibiting definite cleavage-lines, contain narrow laths of a richly coloured reddish-brown mineral, possibly hæmatite, which have a uniformity of direction in the grain, as if determined by its cleavage-planes. In another specimen of chlorite-schist, taken from the foundation rocks of the Old Castle near Salcombe, Professor Bonney called my attention to the form and arrangement of the grains in the clear layers. Without magnifying, the folded zigzags of these colourless bands are quite evident across one part of the slide. Under a low power of the microscope their constituent grains show an elongation transverse to the main layer, and with polarizing apparatus an orientation of colours similarly transverse, these characters of form and optical property being therefore due probably to the pressure which bent the layers.

Certain masses of chlorite-schist occurring in the northern part of the district call perhaps for some special notice. Specimens for the microscope were taken from the points on opposite sides of the main estuary north of Salcombe, which I have called for distinction "Snapes" Point and "Scoble" Point. The usual minerals (chlorite, quartz, epidote) are present, and in the Scoble slide occur some grains of the cleaved mineral and some which seem to be felspar; we may note examples of simple twinning, and others of multiple twinning after the manner of plagioclase. One very interesting specimen was pointed out to me by Professor Bonney, where the members of the compound crystal are distorted, waved, and even broken across and displaced—an additional proof of the action of pressure, which had seemed to me marked in this rock even in hand-specimens, and emphasized by the evidence of the microscope-slides. The section of the Scoble rock shows quartz-grains, occurring, for the most part, separated in the chloritic ground-mass, and many of the grains elongated, with their long axes parallel to the lamination. In the Snapes specimen knots of quartz appear frequently as if squeezed out into rather long irregular bands, in which the mineral has assumed the ordinary schist or quartzite characters. Some of the separate grains are of very flattened form. In the mass the rock exhibited, throughout, a close compressed look, but was traversed at places by bands of apparently different mineral constitution. The evenness of these layers and the compressed look, taken in connexion with the micro-structure already noted, seem to suggest that the rock had suffered from a pressure somewhat normal to the bands, and that the lamination may have existed in some form in the rock as a previous stratification-foliation.

2. *Micaceo-chloritic Schists*.—An interbanding of some mica- and chlorite-schists in the cliff near Rickham Signal-Station yielded a specimen containing both mica and chlorite, with layers of quartzose and other colourless grains, some cleaved and some exhibiting twinning. Scattered about with epidote are small garnets, abundant

in the mica-chlorite layers, rare elsewhere. The signs of a crushing of the rock are very evident; the grains are of varying sizes, their boundaries shade off in polarized light with an appearance of secondary deposition, and many are dirty and less clear than usual; the micaceo-chloritic layers also are crumpled as in the true mica-schists. Like this last specimen, a mass of rock from the north of "Snapes" Point might be described as a kind of chlorite-schist; but it exhibits, even in the hand-specimen, a large amount of mica. It is dark-greenish in colour, tough, and weathers to a very rough surface, partly ridged from plates and fibres of mica, partly pitted with roundish hollows irregularly weathered out. A slide cut from this rock shows chlorite largely present in aggregated folia, but, inter-crystallized with it, flakes of white mica in much abundance. This mica seems to agree with that in the true mica-schist, and shows the zigzag crumpling of the folia which is so marked in that series. As in chlorite-schists, granular epidote is abundant, and large grains occur with an indication of cleavage-planes and showing a tendency to break into smaller fragments. Within the ground-mass are fairly large isolated grains of other minerals. Some of these seemed at first not easy to distinguish from quartz; but, unless we may infer its secondary deposition, several characteristics of the grains make this identification difficult, as was pointed out by Professor Bonney, who kindly looked at this and other slides for me. Other grains present show twinning or cleavage, and very many of them exhibit characters which seem to me most like those of kyanite, in some cases the mineral appearing in longish forms with lines of pinakoidal cleavage ($a P \bar{a}$ and $a P \check{a}$) crossed by some of the nearly "perpendicular breaks" of the basal cleavage (O P) described by Fouqué and Lévy * and by Rosenbusch †. In the hand-specimen, I could recognize grains having pearly cleavage-faces and of pinkish or pale brown colour. In the slide all the grains are fairly uniform in size and similar in shape, having a somewhat elongated, elliptical outline (only one showing good suggestion of crystalline form) and the margin at places being fairly even. They contain various enclosures, some of which seem to be epidote, sometimes in rather stumpy crystalline forms; others are clear colourless belonites; and very minute enclosures, such as are common in the quartz of the chlorite-schist, are very abundant. The inclusions, especially the clear belonites, extend, in many cases, in lines parallel to the long axis of the enclosing grain, and often these lines are curved. In some grains, cleavage runs undisturbed obliquely across the lines of enclosures, so that we might perhaps infer the subsequent crystallization of the enclosing mineral around the epidote and belonites. These must in that case have existed previously, and the kyanite, in its present condition, may be posterior to the crumpling and contortion of the rock. It is interesting to note that the longitudinal extension of the kyanite in some examples is roughly in the direction of the

* *Minéralogie Micrographique*, p. 461.

† *Mikroskopische Physiographie der petrographisch wichtigen Mineralien*, p. 345.

planes, and that the grains themselves are sometimes outlined approximately parallel to the curving lines within. I tried to observe the optical characters of the belonites, but not always successfully; some indications seemed to agree with characters of sillimanite—the clearness of the mineral, and its absence of colour, its occurrence in long slender prisms with transverse cracks, and occasionally the appearance of bright colours with crossed nicols; the extinction in some examples seemed to occur at an angle of about 20° , but varied in others.

Frequently in the masses of chlorite-schist seen in the field, there occur thin bands of chloritic rock of brighter green colour and with very smoothed surfaces as if slickensided; even in freshly hewn quarries these bands were generally too fragile to yield slides for the microscope. One firmer band, however, having a more silvery micaceous look, occurs in a quarry by the new road near Snapes Point, and may perhaps be representative. This gives a clear, filmy, apple-green chlorite, and very clear large mica-flakes accompanying an exceptionally small quantity of quartz, most of it exhibiting signs of secondary change. There are numerous grains, some of epidote, some of garnet, and others of a mineral rather resembling garnet, but apparently not isometric, giving a dull purple tint on rotating the stage. The layers are crumpled, the mica-flakes lying at intervals obliquely across the general direction, as if bent down in the slipping.

When we turn to the examination of the most general type of micaceo-chloritic schists, we find some of the best specimens near “Snapes” Point, “Scoble” Point, and Westercomb, all places approaching the northern boundary-line. Macroscopically, these rocks differ from the ordinary mica-schists in being duller in appearance, although rather light in colour, greyish, or sometimes with a slightly greenish tint. In the mass they are generally more evenly bedded. Under the microscope these rocks are found to consist chiefly of mica, chlorite, and quartz, with possibly feldspar and a mineral, more or less abundant, approximating in its cleavages to kyanite, several grains showing interrupted cleavages meeting at an angle of about 56° , and reminding one of the planes parallel to the base and the brachydome (O P and Pa) shown by Max Bauer *. Grains are fairly abundant in these slides having a marked twinning, some quite simple, others slightly repeated; and in one or more examples the crystal is cracked and its parts displaced. The quartz is dirty from the number of minute enclosures, and has the usual schistose structure, irregularity in the size of the grains and shading of their colours in polarized light suggesting subsequent strain of the rock. In many places, larger clear grains are imbedded in a mosaic of small shaded ones and not uncommonly the large grain is cracked across, and the commencing development of the fine mosaic can be traced along the crack. In some slides occur certain granular aggregations which are partly resolvable under a higher power of the microscope into

* Zeitschrift der Deutschen geologischen Gesellschaft, 1878, Bd. 30, Taf. xiv. fig. 1 a.

colourless microliths, somewhat dichroic, if I could trust my not very clear observation; they may possibly be a secondary actinolite. In these micaceo-chloritic slides mica plates at parts form level and continuous layers, at others they constitute bent or wavy laminæ. Occasionally there is an example of a breaking and slipping of the layers at the folds, which I will indicate later, when I speak of similar structures in other schists.

3. *Mica-Schist*.—True mica-schists form the dark massive cliffs which extend towards Bolt Head, with a kind of black-lead sheen, and the paler, more silvery rock of the cliffs near the Start. In the Bolt specimens I identified the constituents described by Professor Bonney, and found one fragment showing good examples of what I believe to be kyanite. The grains are visible without magnifying, and, thus looked at, they are seen to be about $\frac{1}{16}$ inch in diameter, to be blackish in colour, and to have somewhat of a prismatic form. Under the microscope the grains, some of them, show clear kyanite-like cleavages, and in one is a good example of twinning. Where this clear mineral occurs, it abruptly interrupts

Fig. 2.—*Crystal of Kyanite in Mica-Schist near Bolt Head.*
(Enlarged 70 diameters.)

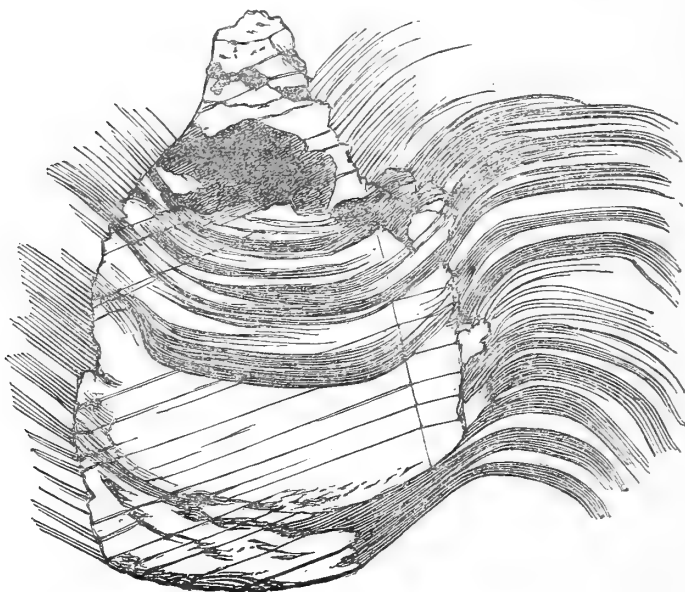

The schist consists mainly of chlorite, white mica, and "black mineral," and its layers pass on through the kyanite. The kyanite shows one good cleavage, with interrupted planes, and is twinned.

the micaceous and chloritic layers; but the ferro-carbonaceous material (as I infer it to be from Professor Bonney's description) seems to continue on in its own wavy laminæ through the kyanite (fig. 2). Here, therefore, where the grains are larger, they contain more foreign deposit, some of them being almost full of the black dust; but its arrangement seems only explicable by supposing the growth of the kyanite-grain *in situ* in the rock. The schist from Start Point seems to have in it less of the black mineral, its mica-

folia are clear and well defined, although small and at places irregularly intercrystallized with quartz. The quartz shows minute agglutinated grains, and has the appearance of having suffered from pressure. In all these slides, I was on the look out for evidence of a secondary cleavage-foliation, and I could trace in all the beginnings of such a structure. The thin folia have given way along some of the sharp abrupt folds, as is shown in the figure given in the article before quoted *, and the secondary planes thus here and there arising consist of the black mineral with some mica-folia.

B. *Macroscopic Structures.*

1. *Mica- and Micaceo-chloritic Schists.*—In hand-specimens the mica-schist gives interesting study of various forms of crumpled and contorted beds. In many places examples may be found of a slipping of the zigzagged layers, being an illustration of what might be classed under “strain-slip” (*Ausweichungs-*) cleavage. In the schist of the Bolt Head, Professor Bonney has described how the beds are folded and contorted, and how the rock readily breaks up “into rude prisms.” This tendency seems due to the schist being traversed by two sets of divisional planes, one parallel with the original stratification-foliation, the other marking a subsequent cleavage-foliation. The cleavage-surfaces have, on the whole, a smoother, more continuous polish; while the original folia are thinner, closer, but more crumpled, and therefore give rise to surfaces more liable to break with small irregularities.

In certain areas the schists, whether mica- or micaceo-chloritic schist, have a tendency to split along broadly undulating planes, which do not entirely follow the lamination. This is a marked character in much of the rock near Start Headland and at several localities in the northern part of the district. Near Gullet, on the arm of the estuary from South Pool, just before mica-schist sets in, the chlorite rock contains what I should judge to be micaceo-chloritic bands, and these are traversed by undulating planes. Thus these bands have a tendency to split along curving surfaces, dividing the rock into somewhat rounded rhomboids, within which the quartz often thickens at places into little knots or eyes. Here the planes of weakness seem to include in their course part of the slip-planes or planes of cleavage-foliation, and part of what we may consider true bedding-planes. There must in that case have been some modification of the structure, induced by the pressure which the rock has undergone; and I thought that possibly the cause could be connected with the more marked presence of quartzose layers, which might have helped the bending-over of the planes of weakness, by offering a resistance to the cleavage-slipping. Passing now to other examples of like structure, I would note a rock of mica-schist on the beach near Lannacombe, whose surface, polished by the waves, exhibits, with greater clearness and on a more minute scale, similar markings to those of the Gullet specimen. Here, blacker patches in the silvery mica-schist seem, in consequence of the structure

* Quart. Journ. Geol. Soc. vol. xl. 1884, fig. 7, p. 15.

described, to tail off where the cross planes break the lamination. Very similar to this is a micaceo-chloritic rock from the shore opposite Gullet, which I examined with the microscope. In the hand-specimen blacker bands continually tailing off seem to cause an incipient formation of "eyes" of the darker material. These bands, under the microscope, are found to consist of chlorite, mica, and a quantity of a black mineral present in all my slides of micaceo-chloritic rock, which both here and in some others consists markedly of small crystalline masses rather flattened in form, and ranging along the lamination, like the titaniferous iron-ore shown in the Scourie-Dyke schist*, only the ferrite in my slide is more abundant. Here (as well as in one other slide) I thought it accompanied by grains of sphene. Some of the micaceous layers present an appearance as if they were flowing around the larger grains of quartz; and the hand-specimen, like others of the micaceo-chloritic group, has a very squeezed look. The slide has the structure already noted as generally belonging to the group—the small mosaic of quartz granules surrounding larger grains which are sometimes broken across; and the aggregations of microliths are also present. This rock was obtained near Westercomb, from within 60 yards of a junction with the phyllites. In other northern localities of the district the curving fracture-planes, as seen in hand-specimens, are very marked in schists which have what seemed to me a specially slickensided and crushed look; and this occurs where I am inclined, from stratigraphical relations, to suspect that a line of fault occurs, which has very possibly split and followed two directions, as, for example, in the point opposite Westercomb.

On the whole, the characteristic of the mica-schist of South Devon seems to be a tendency to develop cleavage-planes of less or greater force, which become, at places, fairly well marked, although not in an equal degree with the original foliation-planes.

2. *Chlorite-Schists*.—Certain structures in the chlorite-schist, when it is studied in the field, seem to require some notice; but I am very diffident about making any suggestions as to their relations. Apart from any ferruginous decomposition, the chlorite in weathering acquires often a paler shade, sometimes almost whitish, and sometimes a delicate pale sea-green. This last colour I generally found occurred in parts protected from rain-wash, and I have never seen a more beautiful study in rocks than that in some of these chlorite-masses where, receding slightly beneath a projecting ledge, they expose a surface coated with the soft pale sea-green dust. The picturesque appearance is increased by the tendency to pitted weathering here, as elsewhere, exhibited, which has already been described by Professor Bonney. In other exposures, I noted a tendency to rather regular rhomboidal divisions. These two structures I should suppose nearly related; but the rhomboids at all events seem to be due to the development of two obliquely crossing sets of planes, the one set being in the direction of bedding, the cause of the other set being more difficult to prove. It might perhaps be a kind of jointing; but there is some

* Teall, 'British Petrography,' pl. xx. fig. 2.

slight evidence which would rather connect it with the effects of pressure. One example, which had some weight with me, was a case of chlorite-schist interbanded with a 15-inch mica-band. The mica-schist showed puckerings, which I can best describe as giving an outline roughly duplino-dentate, and the transverse planes of the chlorite ran up into the sharp teeth of the puckerings. It seemed as if the force which crumpled the mica-band had developed the oblique planes in the chlorite. At other localities also, the divisions seemed to be suggestive of pressure-planes, as in exposures near Rickham Signal-station, on the shore east of Portlemouth Parsonage and elsewhere. For comparison with these examples I searched on the shore south of Portlemouth for an occurrence in chlorite-schist, referred to by Professor Bonney*, and described as a cleavage-structure, and I think the cases I have quoted will bear a similar explanation. To such pressure-planes crossing those of bedding, modified by the not very plastic material of the rock in which they are developed, I am inclined to attribute the irregularly worn surfaces of the chlorite-schist; since the hollows which weather out at places can be found in all gradations from regular angular rhombus-shapes to rounded and irregular pits. The rounded depressions, like the angular ones already described, follow planes of bedding; in one example I traced them along the contortions of a corrugated mass of chlorite-schist. Where the pitting was most irregular in its arrangement, the beds had often suffered such foldings and dislocations that it was difficult, or even impossible, to track the bedding-planes.

The angular markings I have alluded to were generally rather local in their occurrence; but over large masses of chlorite-schist there was a development of a second set of planes, presumably joint planes, along which the rock continually broke up and slipped. This often gave erroneous impressions as to the dip of beds seen from a distance.

III. STRATIGRAPHICAL RELATIONS OF SOME OF THE METAMORPHIC ROCKS.

In this part of the paper I shall restrict myself mainly to the small northern area beyond Portlemouth, which was not specially examined by Professor Bonney. The best exposures are along the main Salcombe estuary, whose shores, extending roughly from north to south, cut across successive beds. The eastern cliff is perhaps rather less disturbed, and from it chiefly we may describe a typical succession.

1. (a) *Interbanded Series of Main Estuary and Batson*.—South of the fault, near Halwell Wood, we come to a mass of mica-schist, partly brown from decomposition, which dips northerly and extends about 100 yards; beyond this, chlorite-schist is exposed. Hence, nearly to the beginning of "Scoble Point," we have beds, at first and at places, with variable or southerly dip, but, on the whole,

* Quart. Journ. Geol. Soc. 1884, vol. xl. p. 9.

dipping to the west of north. These are chlorite-, mica-, and mica-ceo-chloritic schists alternating one with another. Bands only a few feet thick or even less occur; but the average thickness may be taken as about 50 feet, though there are two masses of mica-schist nearly 200 feet in thickness. With few exceptions the beds quietly overlie, and after looking out carefully for evidences of repetition or overfolding, I came to the conclusion that these rocks probably represented a true stratigraphical succession. This series is not quite so well shown along the western shore; here a westward thinning-out of the chlorite bands is suggested, unless they come in partly where exposures are wanting or beds disturbed. Further west, the rocks are exposed in roadside cuttings, one at Lower Batson, and one to the north of it close to a phyllite outcrop, and also along the shores of Batson Inlet. Here the eastern cliff has an extensive development of mica-schist, but part of it, much gnarled and contorted and with a changed dip, may possibly have cut out, by faulting, the chlorite-band, which would otherwise have continued to this place from the western shore and from the lane by the cemetery. The general dip is northerly or to the west of north, varying from 35° to 80° , but often at about 60° to 70° .

1. (b) *Chlorite-Schist of Scoble and of Snapes*.—To the south of the interbanded series, on both sides of the main estuary, a thick bed of chlorite-schist has resisted the action of the water and still projects in the opposite headlands of "Scoble" and of "Snapes." This chlorite-schist is closely and evenly laminated, very firm, at places so compact as to be almost flinty in appearance, and has altogether a squeezed look, which is confirmed by the microscope slides that I have already described.

Salcombe and Southwards.—This chlorite-schist seems to strike to the northern part of the large mass on which Salcombe is built, and of this there are exposures, as Professor Bonney has described, as far south as an alley beyond the Ferry. Southward from this alley, at an exceptionally low tide, I was able to scramble along the shore, and found the cliffs, nearly to the Old Castle, to consist of mica-schist, folded and contorted and nearly vertical, but striking boldly out to the north of east. As the road on the top of the hill, after leaving Salcombe, cuts most of its way through mica-schist, of which rock there is one quarry by the road and two on the southern slope overlooking North-Sands valley, it would seem probable that to the south of Salcombe the hill mainly consists of the mica-formation until we come to the chlorite-schist forming the foundation of the Old Castle ruin and worked in the quarries near North Sands. Here I would suggest the possibility of a faulted junction, and of a southerly pressure overturning the chlorite and some interbanded beds, and thrusting them against the mica-schist. There seemed some grounds for the idea in the aspect of the cliffs between the Old Castle and North Sands—the beds are disturbed, contorted and broken, and form a wild scene of rugged points of cliff, worn into caves, and weathered irregularly to yellows and reds, the brighter colours of decomposition; the beach is a piled-up mass of

huge fallen blocks. The dip of these beds varies, but on the whole seems to incline southerly at one spot, being to W. of S. at quite a low angle, about 30° , while the mica-schist to the north, as I have said, seems nearly vertical, or with a high dip towards the north. Moreover, opposite the Old Castle is a good junction, which may mark, if not the main fault, a minor break connected with it, where the chlorite rock with a dip to W. of S., much jointed and marked by cross planes, overlies mica-schist with a dip to E. of S.; the true nature of the latter is almost concealed by the uniform deep red tint which it has assumed in decomposition (fig. 3). If this chlorite-

Fig. 3.—Cliff opposite the Old Castle near Salcombe.

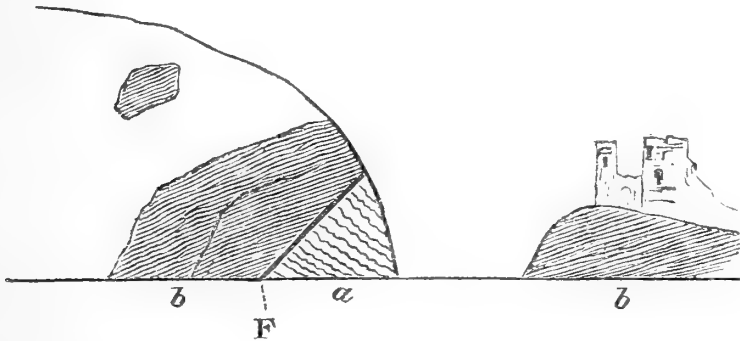

a. Mica-schist, massive, of deep red colour.

b. Chlorite-schist.
F. Line of fault (?).

schist and these interbandings have been thrust northward, the chlorite-rock, which occurs in a lane from north of South Mill to north of Combe, might possibly represent the same mass, whose outcrop had been carried further north out of its proper line of strike; but the beds in this inland exposure seem less disturbed and retain their northerly dip where I had opportunity of testing it.

I was able, during the same favourable tide, to traverse hastily the shore from North to South Sands, passing from the southerly dipping chloritic rock, over the beds marked by Prof. Bonney as showing much disturbance. They consist of a rather thick mass of mica-schist, agreeing in strike to N. of E., but with an almost vertical dip and much folded, possibly bounded on the south by a small fault, where there follow, first, chlorite-beds nearly vertical and with variations of dip, and then, as far as South Sands, interbandings of chlorite- and of mica-schists, exhibiting a southerly dip. The mica-schist in these cliffs beneath Molt agrees in its appearance with the larger masses occurring to north and to south; but the greatly diminished thickness would be difficult to explain on this hypothesis, and I incline to consider it a lower band appearing beneath a fold of the chlorite-schist.

2. *Mica-Schist, with (?) Interbandings.*—Turning back to the district beyond Scoble Point, we find, south of its chlorite-schist, mica-schist rising and extending very continuously along the northern

shore of the side estuary, being possibly part of an interbanded series, the remains of which to the south still occur along the opposite shore. The mica-schist strikes in the common direction of N. of E., and has often a high northerly dip; it is mostly nearly vertical and much folded. At places the dip varies, and the beds have a squeezed look, rather like those in the mica-schist point up the estuary. From the uniform direction of strike, the mica-schist is cut very obliquely by the shore, which trends eastwards from Scoble; but, bounding a small inlet in this shore, a cliff occurs, which cuts across the beds; although much weathered and overgrown, we can see that they consist of similar mica-schist. In this side estuary, the southern shore, passing Portlemouth Parsonage, exposes interbandings, some of only a few feet, some thicker. The rather massive chlorite-schist, which is quarried near the old limekiln, is of such small extent that I place it and also the chlorite-schist of the cliff north of Portlemouth Ferry as a subordinate part of this series. The dips of the latter mass of chlorite-schist rather vary, but the rocks of this series have a general dip to the W. of N.

3. *Mica-Schist (of Portlemouth Ferry).*—They would thus probably overlie the large mass of mica-schist found along the shore to Portlemouth Ferry and beyond, which has previously been described. Similarly, this interbanded series, dipping northerly, seems along the estuary shores to overlie mica-schist, about a quarter of a mile north-west of Good Shelter. The schist, with one rolling over, dips northerly, although towards Waterhead it seems to change, but is not well exposed. The mica-schist is also traceable inland near Portlemouth church, and at places along the lanes south of Waterhead estuary, notably near Hawkshead. The strike here is well marked, still to about 10° N. of E., and the dip is about 70° to W. of N.

Estuary shores southward of South Pool.—Passing now to exposures further eastward, we have rather more difficulty in deciding their relations. First, in completing our survey of the estuary shores, we find along the arm descending from South Pool, south of the phyllites already noted there, exposures of chlorite- or interbanded schists; these extend southwards, and form the point east of Westercomb, and also the cliffs of the opposite shore north and south of Gullet. The beds are partly normal chlorite-schist, such as those quarried opposite Gullet, partly mica- and micaceo-chloritic bands, resembling those obtained from the main estuary.

Parts of these beds are rather out of the direction of the strike of chlorite-schist from the westward; but this, I think, might be from a faulting of the district. The slickensided look in the mica-schist of the point opposite Westercomb, the changed, variable and high dips of the Gullet beds and those opposite, all seem to support the idea of faults having broken the country near. Such faults may have partly determined the lines of the estuary. If we suppose these chloritic beds to be equivalents of the Scoble-Point rocks, and to have been partly displaced to the southward, then there is some difficulty in accounting for the mica-schist, which forms the cliffs nearly all the way from a little south of Gullet around the projecting

point and up the estuary branch to Waterhead. It seemed possible, however, that the rocks had been thrust northward and that the mica-schist might belong to the mass occurring at Good Shelter, stretching westward, and probably, as we shall describe, eastward also.

The Point, which projects where the two branches of the estuary join, is occupied by mica-schist much folded, varying in dip, often nearly vertical, and so crushed and slickensided that small fragments have quite a phyllite look; indeed they split up into thin folia, so as to be almost describable as "papery." About one third the distance from the point to Waterhead along the northern shore, these schists pass into mica-schist of more usual character, folded and gnarled, but dipping steadily to the W. of N., with one interbanding of chloritic beds.

Inland, eastward of South Pool.—Eastward of South-Pool estuary, we can trace the beds which are successively cut out by the faulted junction, and which probably form a downward succession. With the exception of the chlorite-schist which occurs first, whose disturbance we may possibly correlate with that of the beds near Gullet, these inland exposures show a general dip to the N. or W. of N. Near Wilton and eastward of it, chlorite-schist occurs exposed by roadsides and in several quarries; the dip is not altogether uniform, especially at places approaching the boundary line, but is partly in the general northerly direction. Next, underlying, is a mass of mica-schist cropping out around Chivelstone, at and northward of South Allington, and cut by the main fault at Killington, having a uniform strike and northerly dip. There is evidence of chlorite-bands occurring at places in the mica-schist. I would venture to suggest that, possibly, this mass may be a continuation of the Portlemouth-Ferry schist. Underlying the mica-schist, chlorite-schist again occurs (including some mica-bands) at Bickerton, and is quarried on the south of the valley to the eastward.

Summing up the succession in this northern area we seem to have, in descending order, as shown in the annexed section (fig. 4), which is only diagrammatic:—

1. (a) Interbanded series, found south of Halwell Wood, and on the opposite shore, also near Lower Batson.

(b) A thick band of chlorite-schist, at Scoble and at Snapes Point, west of Batson inlet and extending beneath Salcombe. On the coast this might be represented by the Westercomb-Point and Gullet rocks and by those near Wilton and eastwards, but I rather prefer to place these with the interbanded series, 2 (b).

2. (a) Mica-schist north of the side estuary.

(b) Interbanded series (including one or more marked masses of chlorite-schist) remaining on the southern shore of the side estuary, doubtfully including the Westercomb, Gullet, and Wilton rocks.

3. Mica-schist of Portlemouth Ferry and of inland exposures occurring near Good Shelter and Waterhead, possibly including the rocks of the point south of Gullet, and probably continued in the Chivelstone, South Allington, and Killington exposures.

4. Chlorite-schist of Bickerton, which I have not attempted to

trace westwards, so that its presence in the line of the annexed section is inferential.

Fig. 4.—Generalized Section across the Eastern Arm of the Estuary.

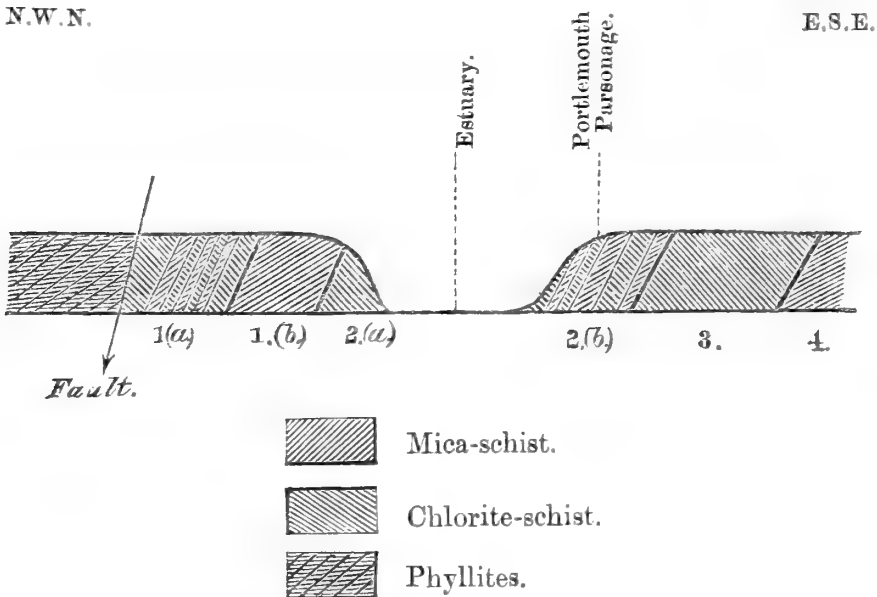

IV. SUMMARY.

I. As to the relation of the South-Devon schists to the adjacent rocks, all observations which I have been able to make support Prof. Bonney's statement that the slaty beds are markedly distinct from the true metamorphic rocks to the south, and that there is no evidence of progressive metamorphism in this district.

II. I have indicated some additional illustrations in these metamorphic rocks of the results following from the action of secondary forces. That both the chlorite- and the mica-schists, however originally formed, had been later affected by lateral pressure is shown in Prof. Bonney's paper, where he several times alludes to the crushing of the one series and the crumpling of the other. The indications of a folding of layers in chlorite-schist are but rarely exhibited with clearness; but such structures as the transverse planes locally occurring, the pitted weathering, and the "arenaceous aspect" alluded to by De la Beche, seem partially due to the effects of lateral pressure. In other examples there is a compressed look, evidencing apparently similar force differing in direction. The microscope has given additional evidence of the crushing of the chlorite-rock, shown in the breaking up of quartzose layers, the fracture of individual crystals, and the appearance of much secondary mineralization; while a squeezing of the beds is indicated by the pressed-out form of the layers and the elongation of their constituent grains. In mica- and micaceo-chloritic schists the pressure to which they have been subjected has resulted in a crumpling of the layers, often in the formation of strain-slip cleavage-planes exhibited in hand-specimens and under the microscope, and at places has given rise to slickensided, crushed and even papery schists. The larger

effects of pressure are seen in the general folding of the beds with a dominant strike from east to west, and in the high dip of the strata, sometimes even vertical, thus indicative of a great thrust along a S. to N. line, no doubt in connexion with that which caused the folding of strata in the long axial region, stretching from Devonshire away to the Hercynian range.

III. In tracing stratigraphical relations among the northern metamorphic rocks, I have pointed out extensive examples of inter-bandings there occurring. Mica- and chlorite-schists alternate in thin layers or thicker beds over a fairly large area in the north, as they do also, perhaps more locally, in other parts, reminding one of the descriptions given by Prof. Bonney, in his Presidential Address*, of rocks in more than one locality, where he asserts the necessity of some material distinctions in the original beds. The mineral bands in these South-Devon rocks may be of an inch or a few inches in width, but often they are to be measured by feet, and, as I have shown, the alternating and generally even-bedded series south of Halwell Wood consist of masses, on an average, some 50 feet thick. The limit of each bed is often abrupt and distinctly marked off from the next in succession, although many gradations can be obtained by collecting from particular and often separated areas. If it should be that we have here an example of a stratification-foliation, this will lead us back to an anterior epoch when the great Channel mountains were not, and will suggest to us the wide problem of the origin of these rocks and the question of a primary metamorphism.

I cannot conclude without expressing my indebtedness to Prof. Bonney, not only for the help his paper afforded me, but also for valuable suggestions and kind encouragement in this endeavour to carry on his work in the south of Devonshire.

* Quart. Journ. Geol. Soc. (1886), p. 46.

51. *On BOULDERS found in SEAMS of COAL.*

By JOHN SPENCER, Esq., F.G.S. (Read June 23, 1887.)

IN working the coal-seams of Lancashire, particularly in those seams found near the Gannister mine, from time to time isolated boulders have been discovered, the position of which it is not easy to explain.

These boulders are not always of the same kind. They generally consist of granite, quartz, or quartzite, and probably of local rocks which do not particularly attract the attention of the workmen in the collieries. They vary in size from an inch to six or eight inches in diameter, the largest being of granite.

A fine specimen has lately been found at Old Meadows Pit, near Bacup, Lancashire, by Mr. John Lord, Bacup. It weighs 6 lb. The granite is composed of quartz, reddish felspar, and hornblende.

This boulder was imbedded in the chief coal of the Rossendale district, the Gannister or Mountain Mine, at a distance of 180 ft. from the surface of the ground. Between this seam and the surface, besides sandstones and shales, are found the Upper Foot or Bullion Coal, the Forty Yards' Mine, and a small Cannel Coal, as seen in the accompanying section:—

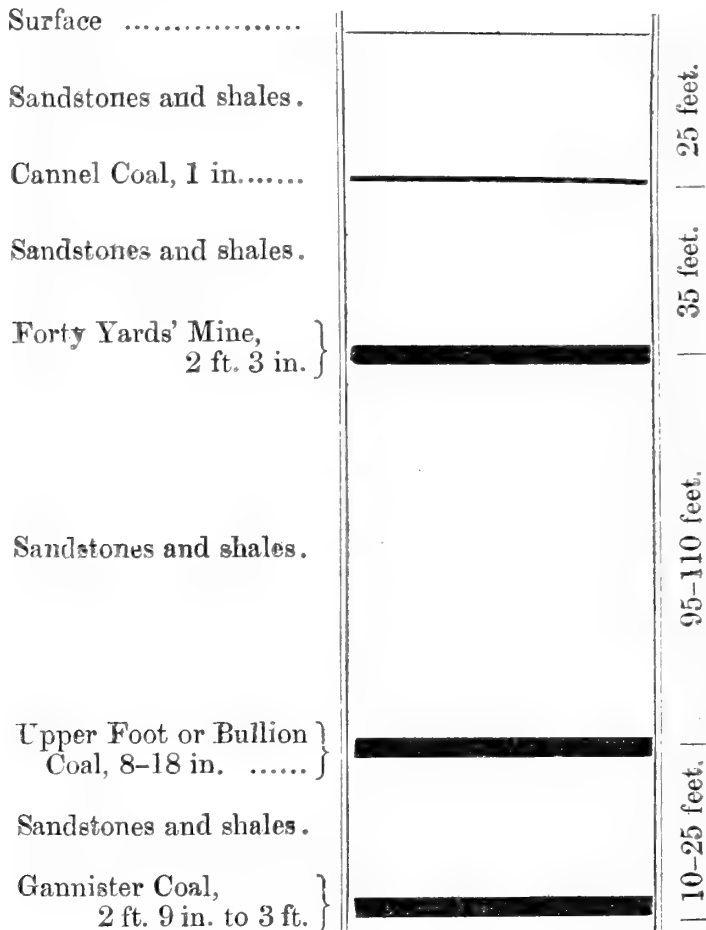

There was no trace of disturbance in the strata near where the boulder was found. Similar boulders have been found at Crawshaw-booth and Goodshaw Hill, about four miles from Burnley, at Wholaw

Nook and Burnt Hills Coalpits, in the same district, and at Higher Dog Hill, Oldham. They are also said to occur in the neighbourhood of Leeds.

The boulders in every case are isolated. Sometimes they occur *in* the bed of coal, and sometimes at its junction with the overlying rock. The boulders or pebbles, in the instances I have seen, are invariably waterworn and rounded.

Two possible explanations of the occurrence of boulders in this anomalous position may be suggested, namely, transportal by being entangled in the roots or branches of trees, and the agency of floating ice. It is by the latter means, I think, that the boulders observed were in all probability conveyed to the spots where we now find them. The chief evidence in its favour consists in the presence of rocks brought from a distance, and the apparent absence of local rocks.



GENERAL INDEX

TO

THE QUARTERLY JOURNAL

AND

PROCEEDINGS OF THE GEOLOGICAL SOCIETY.

[The fossils referred to are described; and those of which the names are printed in italics are also figured.]

- Abergele, tombstone in churchyard of, 99.
- Aberhyd, section in sea-cliff N.W. of Bath House, 76.
- Acer*, sp., 290.
- Adur and Ouse watershed, section across the, 656.
- and Arun watershed, section across the, 656.
- Age of the rocks of the Malverns, 534.
- Aldershot, Bagshot beds of, 431; well-section at South Camp, 434; well-borings at, 439.
- Town, section across, 438.
- Alloy of nickel and iron in New Zealand rocks, *Proc.* 3.
- Allport, Mr. S., award of the Lyell Medal to, *Proc.* 34.
- Alluvium of the Vale of Clwyd, 97.
- Amphibolite at Roscoff, 317.
- Amphibolites of the Ile de Groix, 303; of the neighbourhood of Quimperlé, 311.
- Analyses of Gault-marl from Roydon, 586; of Gault-marl from Fancourt brickyard, 586; of hard Chalk-marls from Roydon and Farnham, 586; of Chalk-marls from Wiltshire, Farnham, and Horningsea, 587; of the Sponge-bed and Inoceramus-bed at Hunstanton, 587; of the Chalk-marls of Grimston, Roydon, and Dersingham, 588; of Red Chalk from Hunstanton, 588; of Japanese Piedmontite, 477; of rocks Q. J. G. S. No. 172.
- from the Herefordshire Beacon, 490, 499; of eucrite lava from Thjórsá in Iceland, 498; of diorite from Swinyard's Hill, 502; of the water of the Terata Geysir, 169; of Bagshot Beds, 379.
- Angolat, 238.
- Anniversary Address of the President, *Proc.* 38-82. *See also* Judd, Prof. J. W.
- Annual Report for 1886, *Proc.* 8.
- Archæan rocks in Brittany, 319.
- rocks in Sark, Herm, and Jethou, 334.
- Arctic glaciers, 399.
- Ardtun, Carsaig, &c. in Mull, gravels and leaf-beds of, 270.
- , Mr. G. A. J. Cole on the constituents of the gravel of, 276.
- beds, 270, 272.
- deposits, geological age of the, 291-299.
- Head, diagrammatic elevation of, 271; sections in, 275, 278, 279, 280.
- Arenig Drift of the Vale of Clwyd, 74.
- Aristosuchus pusillus*, 221.
- Arun, section across the valley of the, 640.
- Basin, superficial geology of the, 637, 643.
- Arundel Park, 367.
- Ash ejected from Mount Tarawera, 185, 186.
- Ash Grange, well-boring at, 436.

- Ash Green, section from Gravel-pit Hill, Aldershot, to, 435.
- Ash-Green Station, well-boring at, 636.
- Ash Station, section at, 435, 436.
- Ashurst, section from, to Henfield, 656.
- Astartian, 261: of the Bernese Jura, 237; fossils of the, 238: of the Southern Jura, 244; fossils of the, 244.
- Augite-andesite ejected from Tarawera, 184.
- Australian Tertiaries, Revision of the Echinoidea from the, 411.
- Bacchus-Marsh beds, 191.
- Bacup, section of Old Meadows Pit, near, 734.
- Bág, Cretaceous Echinoidea from near, 150.
- Bagshot Beds of the London Basin, 374.
- and London Clay, 431; table of borings in the, 441.
- Bagshots in the Walton-Common section, 444.
- Balæna primigenia*, 9.
- Balænidæ, 8.
- Balænodon, 14.
- Balænoptera defnita*, 11.
- *emarginata*, 12.
- Bannalec, 304, 305.
- Banné, 239.
- Barkly, Sir Arthur, on the slip of a peat-bog in the Falkland Islands, *Proc.* 2.
- Barret Ringstead, Melbourn Rock at, 571; section at, 571.
- Barton Bendish, Melbourn Rock near, 567.
- Basalts of Ardtun Head, 272.
- Bassecourt, 238.
- Beach, ancient, and boulders, near Braunton and Croyde in South Devon, 657.
- , shell-, at north end of Herm, 333; raised, on Jethou, 333.
- Bearwood, section through, 388.
- Bedding, absence of true, among the crystalline rocks of the Malvern Hills, 534.
- Beetle, wing-case of, from Ardtun, 289.
- Belemnitella plena, zone of, 563.
- Belemnosphius, 15.
- Belon river, intrusions of granite in a micaceous gneiss on the, 313.
- Bernese Jura, upper Jurassic rocks of, 230.
- Bigsby Gold Medal, award of the, to Prof. C. Lapworth, *Proc.* 37.
- Biotite-gneiss, from North Hill, Malvern Range, 494; from Swinyard's Hill, Malvern Range, 502, 503, 504.
- Boar's Head, Rotomahana, 171.
- Bœhmeria antiqua*, 291.
- Bolt Head, crystal of Kyanite in mica-schists from near, 724.
- Bonney, Prof. T. G., on the structures and relations of some of the older rocks of Brittany, 301.
- Borings in Kent, 197; in the London Clay and Bagshot beds, 441.
- Boulder, of grey porphyry at base of cliff south of Saunton Down, 665; of red granite in ancient beach south of Saunton Down, 666.
- Boulders, northern, transportal of, to the Vale of Clwyd, 83.
- , ancient, near Braunton and Croyde in South Devon, 657.
- , quartzite, and grooves in the Roger Mine at Dukinfield, 599.
- found in seams of coal, Mr. J. Spencer on, 735.
- Bourley Bottom, 440.
- Bracknell, section through, 388.
- , sections of Bagshots near, 387.
- Braunton, in South Devon, ancient beach and boulders near, 657.
- "Brassil," 553, 557, 559, 584.
- Brazil, Prof. O. A. Derby on Nepheline-rocks in, 457.
- Brecqhou, granitic rock of, 330, 331; hornblende-schists of, 325.
- Brenets, 242, 243, 246, 247.
- Bressancourt, 239.
- Brick-earth of Hatch, 446; probable geological position of the, 449.
- of Ongar Hill, 452.
- Bridlington, fossils of the drift of, 91, 93-97.
- Brittany, structures and relations of rocks of, 301; resemblances of rocks of, to those of other localities, 320.
- Brodie, Rev. P. B., award of the Murchison Medal to, *Proc.* 31.
- , notes on the Upper Keuper section at Shrewley where fish were found, and on the Trias generally in Warwickshire, 540.
- Broken Basin, Rotomahana, 171.
- Brynelwy, drift near, 82.
- Brynypin, gravels of, 86.
- Bryozoa, Chilostomatous, from New Zealand, 40.
- , Cyclostomatous, from New Zealand, 337.
- , *See also* "Polyzoa."
- Buckhurst, section through, 388.
- Burgh, traps and leaf-beds at, 283.

- Burons, Sark, 327.
 Burwell, Chalk-marl and Totternhoe Stone at, 553.
- Cabo Frio, occurrence of foyaite at, 457, 458.
 Cae Gwynn Cave, 104, 108; flint flake from, 108.
 Caerhug, sea-shells in drifts of, 86.
 Cæsar's Camp, Aldershot, 433, 438, 439, 440.
 "Calcaire à Nérinées," 235, 248, 260; fossils from the, 236.
 Caldas, Poços de, occurrence of foyaite at the, 457, 460.
 — railway, 461.
 — region, sketch-map of the, 470.
 Callaway, Dr. C., on the alleged conversion of crystalline schists into igneous rocks in County Galway, 517.
 —, preliminary inquiry into the genesis of the crystalline schists of the Malvern Hills, 525.
 Callovian, 255; of the Bernese Jura, 230; fossils of the, 231; of the Southern Jura, 242.
 Cambridge Greensand, *Patricosaurus merocratus*, Seeley, from the, 216.
 — —, distribution of the, in West Suffolk and Norfolk, 545; minute structure of the, in West Suffolk and Norfolk, 581; of Suffolk and Norfolk, 593.
 Campinas, railway from, 460, 461.
 Campo Grande, occurrence of foyaite at, 457, 458.
 Caquerelle, 236.
 Carboniferous *Murchisonia*, Miss J. Donald on some, 617.
 — strata, lower, of Scotland, species of the genus *Diphyphyllum*, Lonsdale, in the, 33.
 — and Hawkesbury series, New South Wales, glacial action in the, 190.
 — or Permian deposits in Sao Paulo and Parana, 461.
 Carsaig, Ardtun, &c. in Mull, gravel and leaf-beds of, 270.
 —, section of lower part of cliff at Malcolm's Point, 282.
 Cascata Station, rocks near, 467-469; foyaite near, 467, 468, 470; phonolite near, 471.
 Catopygus elegans, 420.
 Caves and cave-deposits of the Vale of Clwyd, 73, 102, 105.
 Cefn caves, 103, 107.
 — Meiriadog, caves on, 104.
 Cellepora albirostris, 68.
 — coronopus, 68.
 Cellepora costata, 68.
 — *decepta*, 69.
 — tridenticulata, 68.
 — sp., 70.
 Cercopid, hind wing of a, from Ardtun, 289.
 Cetacea of the Suffolk Crag, 7.
 — from the Crag, list of, 17.
 Cetotherium, 12.
 Chalk-marl of West Suffolk and Norfolk, minute structure of the, 582.
 —, fossils of the, in West Suffolk and Norfolk, 573; chemical composition of the, in West Suffolk and Norfolk, 586-588; from the Roydon cutting, 585; from Wiltshire, Farnham, and Horningsea, 587; from Hunstanton, 587; red marls from Grimston, Roydon, and Dersingham, 588.
 — of West Suffolk and Norfolk, 591.
 — and Totternhoe Stone in West Suffolk and Norfolk, 552.
 Chalk Valleys, dry, and Coombe Rock, Mr. C. Reid on the origin of, 364.
 Change of strike and faults in the Upper Cretaceous of West Suffolk and Norfolk, 569, 590.
 Chapel du Mur, 318.
 Chasseral, 244.
 Chatham, depth of second boring at, 197.
 Chattenden, well-boring at, 198.
 Chaux-de-Fonds, 242.
 Chemical composition of the Gault and Chalk-marl in West Suffolk and Norfolk, 585-588.
 Chertsey, section through, 453; London Clay at, 452, 454.
 Cheshire and Lancashire, fossils of the Drifts of, 89, 93-97.
 Chlorite-schists of South Devon, 719, 726.
 Chilostomatous Bryozoa from New Zealand, 40.
 Chloritoid schists of the Ile de Groix, 303.
Chondrosteus acipenseroides, 605.
Choneziphius planirostris, 14.
 Chronology, geological, of Sark, 334.
 Cinetipora elegans, 341.
 Cleavage, strain-slip, 725.
 Cliff of consolidated sand, Saunton Down, N. Devon, 661.
 Clwyd, Vale of, Drifts of, 73; fossils of the Drifts of, 93-97; classification of the Drifts of, 114.
 Clwydian Drift, 79.
 Clypeaster folium, 415.

- Clypeaster gippslandicus, 416.
 Coal-seams, Mr. W. S. Gresley on the formation of, 671.
 Coal, Mr. J. Spencer on Boulders found in seams of, 735.
 Coast-line, change of, in North Wales, 99.
 Coatham Firs, section at, 642.
 Colwick Wood, near Nottingham, notes on Triassic Beds at, 542.
 Colwyn Bay, section in sea-cliff N.W. of Bath House, Abergryd, 76; fossils of the Drifts of, 89, 93-97.
 Combe Chavatte, 233, 234.
 — Grède, 242, 244, 245, 246, 248.
 Conglomerates and sandstones of the Corrego do Quartel, 462.
 Contorted strata, overlain by current-bedded deposits, in the Hawkesbury series of Australia, 194, 195.
 Contour-map of part of the South Downs, 366.
 Convers, 242.
 Conversion of crystalline schists into igneous rocks in County Galway, Dr. C. Callaway on the alleged, 517.
 Coogee Bay, near Sydney, N.S.W., contorted strata overlain by current-bedded deposits at, 194.
 Coombe rock, 365; fossils of the, 365; formation of the, 365.
 — — and dry chalk valleys, Mr. C. Reid on the origin of, 364.
 Coral Rag, 259, 260.
 Corallian, 258, 259; of the Bernese Jura, 233; of the Southern Jura, 243; fossils of the, 244.
 Coralline Oolite, 259, 260.
 Cornbrash, 255.
 Corrego do Quartel, rocks of the valley of the, 461; section of decomposed dyke in the, 463.
 Correlation of the Upper Jurassics of the northern and central Jura, 248, 249; of English and Swiss Upper Jurassic deposits, 250-268; according to Oppel, 250, 254; according to Waagen, 252, 254; according to Renevier, 253, 254; of Purbeck and Portland in the Jura and England, according to Maillard, 266.
Corylites Macquarrii, 290.
 Courgenay, 239.
 Courrendlin, 236, 239.
 Crag, Suffolk, Cetacea of the, 7.
Crassohornera waipukurensis, 349.
 Cretaceous of India and the Isle of Wight, Dinosaurian vertebræ from the, 156.
 Cretaceous strata of the Lower Narbadá Region, Echinoidea of the, 150.
 — series in West Suffolk and Norfolk, lower part of the Upper, 544; map of the outcrop of the, in West Suffolk and Norfolk, 546.
 Creux Derrible, Sark, 325.
 — Harbour, hornblende-schists overlying gneiss at, 328.
 — Harbour gneiss, 326.
 Cribrilina figuraris, 53.
 — monoceros, 52.
 — radiata, var. Endlicheri, 53.
 Crimplesham, Chalk-marl at, 557.
Crisina cancellata, 349.
 Crocodile, Proœlian, Prof. Seeley on a, 212.
 Croyde, in South Devon, ancient beach and boulders near, 657.
 Crystalline schists, on the alleged conversion of, into igneous rocks, in County Galway, 517.
 — — of the Malvern Hills, 525.
 Cuckmere Basin, superficial geology of the, 648.
 Cwm Nannerch, gravels of, 86.
 Cyclostomatous Bryozoa from New Zealand, 337.
 "Dalle nacrée," 242, 248.
 David, Mr. T. W. E., evidence of glacial action in the Carboniferous and Hawkesbury series, New South Wales, 190.
 Davis, Mr. James W., on *Chondrosteus acipenseroides*, Agassiz, 605.
 Delémont, 233, 235, 239.
 Delphinidæ, 15.
 Dentition and affinities of the Selachian genus *Ptychodus*, Agassiz, 121.
 — of a Triassic Saurian (*Galesaurus planiceps*, Ow.), 1.
 Deposits, subaerial, of the Southern Wealden area, 649.
 Derby, Mr. O. A., on nepheline-rocks in Brazil, with special reference to the association of phonolite and foyaité, 457.
 Derbyshire coal-field, south, evidence from the, as to the formation of coal-seams, 671.
 Dereham, West, Chalk-marl near, 557.
 Derrible Bay, Sark, 325.
 Dersingham, Totternhoe Stone at, 559; section at, 560; thinning out of the Gault at, 552.
 Devil's Dyke, 367.
 Devonshire, North, Prof. Hughes on the ancient beach and boulders near Braunton and Croyde, in, 657.

- Devonshire, South, Miss C. A. Raisin on the metamorphic rocks of, 715; map of part of, 716.
- Diabase, altered, from the Herefordshire Beacon, Malvern Range, 496; from the Hollybush Pass, Malvern Range, 500.
- Diagram showing alternation of Gault and Lower Chalk between Cambridge and Hunstanton, 595.
- showing the thinning-out of the Gault, and the amount lost by erosion between Cheddington and Dersingham, 595.
- Diastopora sarniensis, var. perangusta, 342.
- suborbicularis, 342.
- Diatoms, freshwater, presence of, in Bagshot beds, 381.
- “Diglomerates,” 520, 523.
- Dingle, between the Worcestershire Beacon and North Hill, rock from the, 494.
- Dinosaurian remains in the collection of A. Leeds, Esq., of Eyebury, Northamptonshire, 693.
- vertebræ from the Cretaceous of India and the Isle of Wight, 156.
- Diorite, of Galway, foliation in the, 522; sections of, in granite near Glendalough, 520, 521.
- , jointed, section of granite in, near Glendalough, 519, 520.
- , hornblende-gneiss formed from, in the Malvern Hills, 528.
- , from the Dingle, Malvern Range, 494; from the Worcestershire Beacon, Malvern Range, 496.
- Diorite-gneiss, duplex, 532; granite-, 533.
- Diorites from North Hill, Malvern Range, 492, 493.
- from Swinyard’s Hill, Malvern Range, 501, 502.
- in the schists of the Malvern Hills, 526.
- of the neighbourhood of Glendalough, 519–521.
- Diphyphyllum, Mr. J. Thomson on the genus, 33.
- Blackwoodi, 36.
- —, var. approximatum, 36.
- concinnum, 35.
- cylindricum, 36.
- gracile, 37.
- latiseptatum, 37.
- —, var. giganteum, 37.
- —, var. interruptum, 37.
- Dixcart Bay, Sark, 325.
- Dol, section at bend of river Elwy, near, 75.
- Dolerites, fragments of, in the Essex Drifts, 355.
- Donald, Miss Jane, on some carboniferous species of *Murchisonia* in our public Museums, 617.
- Donation to the Library and Museum, *Proc.* 83.
- Dover, well-boring at the convict-prison at, 199.
- Drift, Clwydian, 79; marine, of North Wales, 79, 83; Essex, rocks of, 351.
- Drifts of the Vale of Clwyd, &c., 73; table of fossils of the, 93–97.
- Dry Chalk Valleys and Coombe rock, on the origin of, 364.
- Dukinfield, grooves and quartzite boulders in the Roger Mine at, 599.
- Duncan, Prof. P. M., on a new genus of Madreporaria (*Glyphastræa*), with remarks on the morphology of *Glyphastræa Forbesi*, Ed. & H., from the Tertiaries of Maryland, U. S., 24.
- , on the Echinoidea of the Cretaceous strata of the Lower Narbadá Region, 150.
- , revision of the Echinoidea from the Australian Tertiaries, 411.
- Duplex diorite-gneiss, 532.
- Dürnten, lignite of, 401.
- Dykes, intrusive, in Sark, 332.
- Earthquakes during the eruption of Mount Tarawera, New Zealand, 181–183.
- Easthampstead Church, sections of Bagshots near, 387.
- Echinobrissus australiæ, 420.
- Echinoidea of the Cretaceous strata of the Lower Narbadá Region, 150.
- from the Australian Tertiaries, 411.
- Echinolampas ovulum, 420.
- Ejectamenta of the Tarawera eruption, 184.
- Ekaterinebourg, notice of Exhibition to be held at, *Proc.* 86.
- Elæolite-syenite in Brazil, 457.
- Elsden, Mr. J. V., on the Superficial Geology of the Southern Part of the Wealden area, 637.
- Elwy, River, section at bend of, near Dol, 75; section in the east bank of the, below the Mount, St. Asaph, 81.
- England, Upper Jurassic Rocks of, correlation of, with those of the Swiss Jura, 229.
- Entalophora intricaria*, 340.
- *wanganuiensis*, 340.

- Epidosite from the Worcestershire Beacon, Malvern Range, 496.
 Epidote, peculiar Japanese variety of, 479.
 Equisetum Campbelli, 289.
Equus, Pliocene type of, from Nubia, molar of, 161.
 Eriswell, Middle Chalk at, 565.
 Erosion, marine, of the South Downs, 364.
 Erratic blocks of the Southern Wealden area, 649.
 Eruption of Mount Tarawera, 178.
 Essex Drift, rocks of the, 351.
Eucetus amblyodon, 13.
 Eucrite from the Herefordshire Beacon, Malvern Range, 497.
 — lava from Thjórsá, in Iceland, analysis of, 498.
Euspatangus Laubei, 426.
 — *murrayensis*, 426.
 — *rotundus*, 426.
 Eyebury, Northamptonshire, Dinosaurian remains from the Kimmeridge Clay near, 693.
 Falkland Islands, Sir A. Barkly on the slip of a peat-bog at Stanley, in the, *Proc.* 2.
 False-bedding in the Bagshot beds, 377.
Fascicularia tubipora, 344.
 Faults of the Malvern Hills, 483, 484, 485, 487.
 — and change of strike in the Upper Cretaceous of West Suffolk and Norfolk, 589, 590.
 Felsite, mica-schist formed from, in Raggedstone Hill, 530.
 Felsites, fragments of, in the Essex Drifts, 353.
 Felspar-porphyrites, fragments of, in the Essex Drifts, 354.
 Feltwell, Grey Chalk at, 555; section near, 555.
 "Fer sous-oxfordien," 232, 242, 255, 256; fossils from the, 232, 248.
 Ffynnon Beuno, caves of, 104, 108; fossils from, 110; view of Old Fence at, 111.
 Fincham, Totternhoe Stone near, 558.
 Fisher, Rev. O., award of the Balance of the Lyell Geological Fund to, *Proc.* 35.
 Fishes, remains of, from the Keuper of Warwick and Nottingham, 537.
 Fissures formed in the ground during the eruption of Mount Tarawera, 183.
 Fittleworth Common, section on, 639.
 Flora of the Ardtun leaf-beds, 288.
 Flysch, supposed glacial origin of the, 396.
 Foliation of the igneous rocks of Galway, 522, 524.
 Fontenois, 239.
 Fordham, Totternhoe Stone at, 553.
 Fort de la Croix, 303.
 Fossils, distribution of, in the Drifts of the Vale of Clwyd, Moel Tryfan, Minera, Lancashire and Cheshire, Macclesfield, Kelsea, and Bridlington, 93-97.
 — of the Callovian of the Bernese Jura, 231; of the "Terrain à chailles siliceux," 234; from the "Oolithe Corallienne" and "Calcaire à Nérinées," 236; of the Astartian, 238; of the Pteroceran, 239; of the Callovian of Pouillere, 242; of the Oxfordian of the Southern Jura, 243; of the Corallian, 244; of the Astartian, 244; of the Pteroceran, 246; of the Gault in West Suffolk and Norfolk, 571; of the Chalk-marl in West Suffolk and Norfolk, 573; of the Totternhoe Stone, 577; of the Grey Chalk in West Suffolk and Norfolk, 579; of the Melbourn Rock in West Suffolk and Norfolk, 580.
 Fox Hills, 437.
 Foyaite and phonolite, association of, in nepheline rocks in Brazil, 457.
 —, phonolite- and crystalline inclusions in, 468.
 —, inclusions of, in phonolite, 459, 467.
 Gabbro, hornblende-, from North Hill, Malvern Range, 492.
Galesaurus planiceps, 1.
 Galway, County, on the alleged conversion of crystalline schists into igneous rocks in, 517.
 —, rocks of, 517; gneiss of, 523, 524.
 Gardner, Mr. J. Starkie, on the leaf-beds and gravels of Ardtun, Carraig, &c. in Mull, 270.
 Garnet, peculiar Japanese crystals of, 479.
 Gault of West Suffolk and Norfolk, 590.
 —, chemical composition of the, in West Suffolk and Norfolk, 585, 586; marls from Roydon and Grimston, 585, 586; marl from Fancourt brickyard, 586; distribution of the, in West Suffolk and

- Norfolk, 545; fossils of the, in West Suffolk and Norfolk, 571; minute structure of the, in West Suffolk and Norfolk, 580.
- Gayton, Totternhoe Stone at, 558; exposure of Grey Chalk at, 568; section at, 569; Melbourn Rock near, 569.
- Genesis of the crystalline schists of the Malvern Hills, 525.
- Geology, superficial, of the southern part of the Wealden Area, Mr. J. V. Elsdon on the, 637.
- Giant Buttress, Rotomahana, 170.
- Glacial action in the Carboniferous and Hawkesbury series, New South Wales, 190.
- beds, Carboniferous, in Australia, 190.
- Period, considerations on the, with reference to the antiquity of man, 393; dates assigned to, 393-395.
- periods, supposed recurrence of, 395, 396.
- Glacier-movements, seasonal fluctuations of, 398, 401.
- Glaciers, arctic, phenomena of, 399.
- Glauconic marl at Stoke Ferry, 548, 557; at Crimplasham, 557; of West Suffolk and Norfolk, minute structure of the, 582.
- Glaucophane amphibolites of the Ile de Groix, 303.
- Glendalough, igneous rocks of the neighbourhood of, 519-522.
- Globicephalus uncidens*, 16.
- Glovelier, 231, 239.
- Glyphastræa Forbesi*, Ed. & H., from the Tertiaries of Maryland, U.S., 24.
- Glyptostrobus europæus*, 289.
- Gneiss, banded, of the Pouldu, section of contorted, 308.
- , biotite-, from North Hill, Malvern Range, 494.
- , hornblende-, formed from diorite, in the Malvern Hills, 528.
- , hornblendic, from the Herefordshire Beacon, Malvern Range, 496.
- , micaceous, intrusions of granite in, on the Belon River, Brittany, 313.
- , mica-, formed from granite, in the Malvern Hills, 528.
- , duplex diorite-, 523; granite-diorite-, 533.
- of Galway, 523, 524.
- Gneisses of Quimperlé, 305, 307, 308.
- Gneissic quartz-syenite from North Hill, Malvern Range, 490.
- and other crystalline rocks of the Malvern Hills, 482, 483.
- rocks, association of, with igneous masses in the Malverns, 533.
- Goathurst Hill, section through, 388.
- Gobat, 234.
- Gorrick Plantation, section through, 388.
- Goyag range, 457.
- Grand Moie, Sark, 327.
- Granite, intrusion of, in a micaceous gneiss on Belon River, Brittany, 313.
- , overlying, of Sark, 328.
- , sections of, in jointed diorite, near Glendalough, 519, 520.
- , sections of diorite in, near Glendalough, 520, 521.
- of Galway, foliation of the, 522.
- , mica-gneiss formed from, in the Malvern Hills, 528.
- from the Worcestershire Beacon, Malvern Range, 495.
- or pegmatite, from Swinyard's Hill, Malvern Range, 501.
- , boulder of red, in ancient beach S. of Saunton Down, 666.
- fragments, absence of, in the Essex Drift, 352.
- Granite-diorite-gneiss, 533.
- Granite-vein, contorted, in gneiss, 527.
- Granites near Roscoff, 316.
- Granulite from the Worcestershire Beacon, Malvern Range, 494.
- Granulites, fragments of, in the Essex Drifts, 358.
- Grass-tree, Carboniferous glacial beds at, 192.
- Gravel of Ardtun, Mr. G. A. J. Cole on the constituents of the, 276.
- Gravels and leaf-beds of Ardtun, Carsaig, &c. in Mull, 270.
- Gravel-pit Hill, Aldershot, section from, to Ash Green, 435.
- Greenland, great ice-sheet of, 399.
- Greensand, Cambridge, in West Suffolk and Norfolk, 545.
- , —, *Patricosaurus merocratus*, Seeley, from the, 216.
- Gresley, Mr. W. S., on the formation of coal-seams, as suggested by evidence collected chiefly in the Leicestershire and South Derbyshire coal-fields, 671.
- Grey Chalk of West Suffolk and Norfolk, 596; fossils of the, 579; minute structure of the, 584.

- Grimston, Gault near, 549, 551; boring near, 550.
- Groom, Mr. T. T., on some new features in *Pelanechinus corallinus*, 704.
- Grooves and quartzite boulders in the Roger Mine, at Dukinfield, 599.
- Hällefrinta, 306, 307.
- Hall Sands, boundary of slaty and metamorphic series at, 718.
- Hambleton Oolite, 259.
- Hastings, *Heterosuchus valdensis* from the Hastings Sand of, 212.
- Hatch, brick-earth of, 446, 449.
- Hatch-Farm clay-pit, Woburn Hill, section in, 447, 448.
- Havre Gosselin, Sark, 325.
- Hawkesbury and Carboniferous Series, New South Wales, glacial action in the, 190.
- Heacham, Melbourn Rock at, 570; section at, 570; Totternhoe Stone near, 561.
- Henfield, section from Ashurst to, 656.
- Herefordshire Beacon, Malvern Range, section through the, 488; rocks from the, 496-500; analyses of rocks from the, 498, 499.
- Herm, granitic rock of, 332, 333, 334; shell-beach at North end of, 333.
- , rocks of, 322.
- Herpetocetus scaldiensis, 13.
- Hessle beds, shells of, 90.
- Heterocetus, 12.
- Heteropora napierensis, 348.
- pelliculata, 348.
- Heterosuchus valdensis*, 212.
- Hill, Rev. E., on the rocks of Sark, Herm, and Jethou, 322.
- Hill, Mr. W., and Mr. A. J. Jukes-Browne, on the lower part of the Upper Cretaceous Series in West Suffolk and Norfolk, 544.
- Hillington, section at, 569.
- Hockwold, Grey Chalk at, 555.
- Holaster australiæ*, 420.
- difficilis, 421.
- subglobosus, zone of, 563.
- Hollybush Pass, Malvern Range, rock from, 500.
- Holmston Camp, well-boring at, 204.
- Hope Cove, boundary of slaty and metamorphic series at, 715.
- Hoplocetus, 14.
- Hornblende-gabbro from North Hill, Malvern Range, 492.
- Hornblende-gneiss, formed from diorite, in the Malvern Hills, 528.
- Hornblende-schists of Sark, 324; false-bedding in, 324; overlying gneiss in Sark, 327, 328; overlain by granite in Sark, 330.
- Hudleston, Mr. W. H., supplementary note on the Walton-Common Section, 443.
- Huelgoat, 318.
- Hughes, Prof. T. McKenny, on the Drifts of the Vale of Clwyd, and their relation to the Caves and Cave-deposits, 73.
- , on the ancient Beach and Boulders near Braunton and Croyde in South Devon, 657.
- Hulke, Mr. J. W., award of the Wollaston Gold Medal to, *Proc.* 30.
- , on some Dinosaurian remains in the collection of A. Leeds, Esq., of Eyebury, Northamptonshire, 693.
- Hungry Hill, 440.
- Hunstanton, exposure of Chalk-marl and Totternhoe Stone in cliff at, 561; section of cliff at, 562; Red Chalk of, 563; Sponge-bed at, 563; Grey Chalk at, 571.
- Hutton, Capt. F. W., the eruption of Mount Tarawera, 178.
- Huxley, Prof. T. H., on *Hyperodapedon Gordoni*, 675.
- Hyotherium*, jaw of, from the Pliocene of India, 19.
- *perimense*, 19.
- Hyperodapedon Gordoni*, Prof. Huxley upon, 675.
- Hyperoodon*, sp., 14.
- Ice-action, evidence of, in Carboniferous deposits of Australia, 192, 193; in the Hawkesbury series of Australia, 193, 194; in Siluro-Devonian beds in New South Wales, 195.
- Ice-sheet, of Greenland, 399.
- Ice-sheets of Europe and America in Glacial times, 400.
- Iceland, analysis of eucrite lava from Thjórsá in, 498.
- Idmonea contorta, 339.
- ramosa, 339.
- serpens, 339.
- Igneous masses, association of gneissic rocks with, in the Malverns, 533.
- rocks, effects of intrusion of, in Brittany, 319; of Galway, 518, 524; foliation of the, 522; age of the, 523.
- —, on the alleged conversion of crystalline schists into, in County Galway, 517.
- Iguapé valley, occurrence of foyaitite in the, 457, 460.

- Ile de Groix, 302.
 Implements, stone, from Pontnewydd Cave, 116.
 India, jaw of *Hyotherium* from the Pliocene of, 19.
 — and the Isle of Wight, Dinosaurian vertebræ from the Cretaceous of, 156.
 Inholmes Farm, section at, 645.
 Injection-schists in the Malvern Hills, 532.
 Interglacial warm periods, 397.
 Iron and nickel, peculiar alloy of, in some New Zealand rocks, *Proc.* 3.
 Irony concretions in the Bagshot beds, 378.
 Irving, Rev. A., the Physical History of the Bagshot beds of the London Basin, 374.
 Isle of Wight and India, Dinosaurian vertebræ from the Cretaceous of, 156.
 Isleham, Totternhoe Stone at, 553; well-section near, 554.
 Itacolumite of the Corrego do Quartel, 461; of the Rio das Antas, 471.
 Itambé, occurrence of foyaite in, 460.
 Itatiaia, occurrence of foyaite in the peak of, 457, 459.
 Japan, occurrence of piedmontite-schist in, 474.
 Jethou, rocks of, 322; granitic rock of, 332, 333, 339; raised beach on, 333.
 Jones, Prof. T. R., note on *Nummulites elegans*, Sowerby, and other English Nummulites, 132.
 Jougne, 245.
 Judd, Prof. J. W. (President), Address on presenting the Wollaston Gold Medal to Mr. J. W. Hulke, *Proc.* 30; Address on presenting the Balance of the Wollaston Donation Fund to Mr. B. N. Peach, *Proc.* 31; Address on presenting the Murchison Medal to the Rev. P. B. Brodie, *Proc.* 31; Address on handing the Balance of the Murchison Geological Fund to Dr. H. Woodward, for transmission to Mr. R. Kidston, *Proc.* 33; Address on handing the Lyell Medal to Prof. T. G. Bonney, for transmission to Mr. S. Allport, *Proc.* 34; Address on presenting the Balance of the Lyell Geological Fund to the Rev. O. Fisher, *Proc.* 35; Address on presenting the Bigsby Gold Medal to Prof. C. Lapworth, *Proc.* 37. Anniversary Address, February 18, 1887:—*Obituary Notices of De-*
 Q. J. G. S. No. 172.
ceased Fellows: the Earl of Enniskillen, *Proc.* 38; Sir C. J. F. Bunbury, *Proc.* 39; Mr. George Busk, *Proc.* 40; Mr. J. A. Phillips, *Proc.* 41; Mr. H. M. Jenkins, *Proc.* 44; Dr. H. B. Holl, *Proc.* 46; Mr. Caleb Evans, *Proc.* 47; Rev. W. Downes, *Proc.* 48; Prof. F. Guthrie, *Proc.* 48; Mr. A. Grote, *Proc.* 48; Dr. Hermann Abich, *Proc.* 49; Prof. G. Guiscard, *Proc.* 50; and M. F. L. Cornet, *Proc.* 50. Address on the work done by the Society and its Fellows, on the progress of geology, and on petrological investigations, *Proc.* 51.
 Jukes-Browne, Mr. A. J., and Mr. W. Hill, on the Lower Part of the Upper Cretaceous series in West Suffolk and Norfolk, 544.
 Jura, Swiss, Upper Jurassic rocks of, correlation of the, with those of England, 229.
 —, north and central, correlation of Upper Jurassics in the, 248.
 —, Southern, Upper Jurassics of the, 241.
 Kelloway rock, 255.
 Kelsea, fossils of the drifts of, 90, 93–97.
 Kent, deep borings in, 197.
 Kersélec, bay of, 312.
 Keuper, section in the, at Shrewley, where fish were found, 540.
 — of Warwick and Nottingham, on the remains of fishes from the, 537.
 Kidston, Mr. R., award of the Balance of the Murchison Geological Fund to, *Proc.* 33.
 Killary harbour, Silurian conglomerates of, 523.
 Kimeridge clay, 260, 261, 263, 264.
 Kimeridgian of the Bernese Jura, 239; fossils of the, 239.
 Kingley vale, 367.
 Knockseefin, rocks of, 518; foliation in diorite of, 522.
 Kotô, Prof. B., on some occurrences of Piedmontite-schist in Japan, 474.
 Kyanite, crystal of, in mica-schist from near Bolt Head, 724.
 La Baume, 245.
 Lakenheath, Middle Chalk at, 565.
 Lancashire and Cheshire, fossils of the drifts of, 89, 93–97.
 Lapworth, Prof. C., award of the Bigsby Gold Medal to, *Proc.* 37.

- Lava, eucrite, from Thjórsá in Iceland, analysis of, 498.
- Leaf-beds and gravels of Ardtun, Carsaig, &c. in Mull, 270.
- Leeds, Mr. A., of Eyebury, Northamptonshire, Mr. Hulke on Dinosaurian remains in the collection of, 693.
- Leicestershire Coal-field, evidence from the, as to the formation of coal-seams, 671.
- Leiocidaris, sp., 412.
- Lepralia bistata*, 62.
- foraminigera, 62.
- imbellis, 60.
- longipora, 61.
- *Poissonii*, 59.
- *rectilineata*, 60.
- *rostrigera*, 61.
- *semiluna*, var. *simplex*, 62.
- Les Autelets, Sark, 325.
- Les Praises, 243.
- Leucite rock of Pinhalzinho, 463, 464.
- Lias, Mr. E. A. Walford on some Polyzoa from the, 632.
- Lichenopora clypeiformis, 345.
- Houldsworthi, 347.
- *wanganuiensis*, 346.
- Liesberg, 233, 234; section in quarry near, 234.
- Limestones, fragments of, in the Essex drifts, 361.
- Lion rock, Rotomahana, 167.
- Llandulas, caves at, 104.
- Lockley Park, section through, 388.
- Loche, 245, 247, 248.
- Locmaria, 303.
- Loges, 244.
- London Basin, Bagshot beds of the, 374.
- clay and Bagshot beds of Aldershot, 431; table of borings in the, 441.
- Longbury Hill, section on, 643.
- Lovenia Forbesi, 424.
- Lower Calcareous Grit, 258, 259.
- Lunulites petaloides, 70.
- Lydd, well-boring at, 204.
- Lydekker, Mr. R., the Cetacea of the Suffolk Crag, 1.
- , description of a jaw of *Hyothe-rium* from the Pliocene of India, 19.
- , on certain Dinosaurian vertebræ from the Cretaceous of India and the Isle of Wight, 156.
- , on a molar of a Pliocene type of *Equus* from Nubia, 161.
- Lyell Geological Fund, award of the, to the Rev. O. Fisher, *Proc.* 35.
- Medal, award of the, to Mr. S. Allport, *Proc.* 34.
- Lyons, Mr. H. G., on the London Clay and Bagshot beds of Aldershot, 431.
- Macclesfield, fossils of the drift of, 90, 93-97.
- Malcolm's Point, Carsaig, basalts, gravels, and leaf-beds of, 281; section of lower part of cliff at, 282.
- Malvern axis, classification of crystalline rocks of the, 484.
- Hills, distinction between crystalline rocks of northern and southern portions of the, 482; rocks of the, 481, 489-512; age of the rocks of the, 534; crystalline schists of the, 525.
- Range, plans and section of the, 488; classification of the rocks of the, 505-507; history of the, 507-509.
- Man, the Glacial Period with reference to the Antiquity of, 393.
- , Preglacial, 406, 407; probable date of, 407.
- Mantiqueira Range, occurrence of foyaité in the, 457.
- Map, contour-, of part of the South Downs, 366; of the North Island of New Zealand, 178; of the country round Tarawera Volcano after the eruption of 10th June, 1886, 180; of Sark and the neighbouring islets, 323; of parts of the Provinces of Rio de Janeiro, Sao Paulo, and Minas Geraes, 458; of the Caldas region, 470; of the outcrop of Cretaceous rocks in West Suffolk and Norfolk, 546; of the southern portion of the Wealden area, 650; of part of South Devon, 716.
- Maretia anomala, 422.
- Marham, Melbourn Rock at, 567, 568.
- Marham Hill, glauconitic marl in watercourse at, 558.
- Marine deposits of Wales, Cheshire, and Lancashire, 87.
- erosion of the South Downs, 364.
- Martin, Mr. J., the Terraces of Rotomahana, 165.
- Maryland, *Glyphastræa Forbesi*, Ed. & H., from the Tertiaries of, 24.
- Materials, derived, in the Bagshot beds, 378.
- Megalaster compressus, 422.
- Megaptera affinis*, 11.
- *minuta*, 11.
- Melbourn Rock, range of, 564-570; fossils of the, in West Suffolk and Norfolk, 580; minute structure of the, in West Suffolk and Norfolk,

- 585; of West Suffolk and Norfolk, 597.
- Membranipora annulus*, 47.
- *Dumerilii*, 45.
- *Lacroixii*, var. *grandis*, 45.
- *lineata*, 45.
- *monostachys*, 45.
- *nobilis*, 46.
- *occultata*, 48.
- *solidula*, 46.
- *spinosa*, 48.
- *trifolium*, 48.
- Membraniporella nitida*, var., 52.
- Mesoplodon, 15.
- *longirostris*?, 15.
- Metamorphic rocks of South Devon, Miss C. A. Raisin on the, 715; characters of, 719.
- Metamorphism, effects of, on Palæozoic rocks in Brittany, 319; products of, in the Malverns, 528; period of, in the Malvern Hills, 534.
- Methwold, Middle Chalk at, 566.
- Mica-gneiss, formed from granite, in the Malvern Hills, 528.
- Mica-schist from Raggedstone Hill, Malvern Range, 503; formed from felsite, in Raggedstone Hill, 530.
- Mica-schists of the Ile de Groix, 302; of South Devon, 724, 725; of Portlemouth Ferry, 730; south of South Pool, 730.
- Micaceo-chloritic schists of South Devon, 721, 725.
- Micraster *brevistella*, 421.
- Micropora *lepida*, 51.
- *variperforata*, 51.
- Microporella *ciliata*, 53.
- *decorata*, var. *angustipora*, 54.
- ? *macropora*, 54.
- *magnirostris*, 55.
- Microscopic structure of Bagshot beds, 380.
- Middle Terrace, Rotomahana, 171.
- Midsummer Hill, 534; section through, 488.
- Mildenhall, Middle Chalk at, 564.
- Minas Geraes, sketch-map of part of the province of, 458; occurrence of foyaite in, 460.
- Minera, fossils of the Drifts of, 89, 93-97.
- Moel Tryfan, fossils of the Drifts of, 89, 93-97.
- Monoporella *capensis*, 49.
- —, var. *dentata*, 49.
- *crassatina*, 49.
- *disjuncta*, 50.
- *waipukurensis*, 50.
- Montchaibeut, 238.
- Montmelon, 231, 234, 236.
- Morfa Rhuddlan beds, 98.
- Morlaix, older rocks of, 317.
- Morphology of *Glyphastræa Forbesi*, Ed. & H., from the Tertiaries of Maryland, U.S., 24.
- Mount Tarawera, eruption of, 178.
- Moutier Station, section in cutting north of, 241.
- Mucronella?* *Alvarezziana*, 57.
- *firmata*, 58.
- ? *Liversidgii*, 58.
- *nitida*, 55.
- *Peachii*, var. *octodentata*, 56.
- *porosa*, 57.
- *præstans*, 56.
- *tricuspis*, 57.
- —, var. *waipukurensis*, 57.
- Mud ejected from Mount Tarawera, 185, 186.
- Mud-volcanoes of Rotokanapanapa, 174.
- Mull, gravel and leaf-beds in, 270.
- Murchison Geological Fund, award of the, to Mr. R. Kidston, *Proc.* 33.
- Medal, award of the, to the Rev. P. B. Brodie, *Proc.* 31.
- Murchisonia*, Miss Jane Donald on some Carboniferous species of, 617.
- Murchisonia angulata*, 621.
- *kendalensis*, 624.
- *pyramidata*, 627.
- *sphaerulata*, 629.
- *tenuissima*, 629.
- *Verneuiliana*, 626.
- *zonata*, 628.
- Narbadá Region, Echinoidea of the Cretaceous strata of the Lower, 150.
- Narborough, Melbourn Rock near, 568.
- Nepheline-rocks in Brazil, 457.
- Newton, Mr. E. T., on the remains of fishes from the Keuper of Warwick and Nottingham, with notes on the mode of occurrence by the Rev. P. B. Brodie, M.A., and Mr. E. Wilson, 537.
- New South Wales, glacial action in the Carboniferous and Hawkesbury series of, 190; ice-action in Siluro-Devonian beds in, 195.
- New Zealand, Chilostomatous Bryozoa from, 40; Cyclostomatous Bryozoa from, 337.
- —, map of the North Island of, 178.
- —, Prof. Ulrich's discovery of a peculiar alloy of nickel and iron in some rocks of, *Proc.* 3.
- Nickel and iron, peculiar alloy of, in New Zealand rocks, *Proc.* 3.

- Nine-mile Ride, section through the, 388.
- Noirvaux-dessous, 245.
- Norfolk, on the lower part of the Upper Cretaceous series in West Suffolk and, 544.
- North Hill, Malvern Range, rocks from, 489-494, 534.
- — —, section through, 488; and the Worcestershire Beacon, section through, 510.
- Northamptonshire, Dinosaurian remains from the Kimmeridge Clay of, 693.
- North Wales, change of coast-line in, 99.
- Norway, Mr. W. F. Stanley on the probable amount of the former glaciation of, *Proc.* 83.
- Nottingham, notes on Triassic beds at Colwick Wood, near, 542.
- — and Warwick, on the remains of fishes from the Keuper of, 537.
- Nubia, molar of a Pliocene type of *Equus* from, 161.
- Nummulites, table of the range of, in England, 148.
- Nummulites elegans*, 132, 142.
- *levigatus*, 147.
- *variolarius*, 145.
- Okaro craters, 181, 182, 184.
- Omosaurus durobrivensis*, 699.
- Ongar Hill, brick-earth of, 452.
- Oncoclea hebridica, 289.
- "Oolithe corallienne," 235, 248, 259; fossils from the, 236.
- Orca citoniensis*, 16.
- Ornithodesmus chuniculus*, 206.
- Ornithopsis Leedsii*, 697.
- Ortholophus, 414.
- *lineatus*, 413, 415.
- Otukupuaranga, 176.
- Ouse Basin, superficial geology of the, 646.
- and Adur watershed, section across the, 656.
- Owen, Sir R., on the skull and dentition of a Triassic Saurian (*Galesaurus planiceps*, Ow.), 1.
- Oxborough, Melbourn Rock near, 567.
- Oxford Clay, 256, 257.
- Oxfordian, 255, 258, 259; of the Bernese Jura, 232; of the Southern Jura, 242; fossils of the, 243.
- "Oxfordien calcaire," 242.
- Palæontology of the Upper Cretaceous deposits of West Suffolk and Norfolk, 571-580.
- Palæozoic rocks of Brittany, effects of metamorphism in the, 319.
- — —, Upper, in Sao Paulo and Parana, 461.
- Paradoxechinus novus, 415.
- Parana, Upper Palæozoic deposits in, 461.
- Patricosaurus merocratus*, 216.
- Peach, Mr. B. N., award of the Balance of the Wollaston Donation Fund to, *Proc.* 31.
- Peat of the Clwyd estuary, 99.
- Peat-bog, Sir A. Barkly on the slip of a, in the Falkland Islands, *Proc.* 2.
- Pebbles of the Bagshot beds, 376.
- Pegmatite from a vein at the Wych, Malvern Range, 505.
- Pelanechinus corallinus*, Mr. T. T. Groom on some new features in, 703.
- Pericosmus compressus, 423.
- *gigas*, 423.
- Permian or Carboniferous deposits in Sao Paulo and Parana, 461.
- "Pholadomien," 243, 258.
- Phonolite, inclusions of foyaite in, 459, 467; inclusions in foyaite, 468.
- and foyaite, association of, in nepheline-rocks in Brazil, 457.
- Physeteridæ, 13.
- Physical History of the Bagshot Beds of the London Basin, 374.
- Pichoux, 234, 240.
- Picú, occurrence of foyaite in, 460.
- Piedmontite, crystals of, in Japan, 474-477; optical characters of, 476; analysis of, 477; comparison of Japanese, with that of other localities, 477; geographical distribution of, 478.
- schist in Japan, occurrences of, 474.
- Pinhalzinho, leucite rock of, 463, 464; phonolite of, 464; conglomerate near, 464; foyaite of, 465; sections on railway near, 464; sections across and on the sides of the tunnel near, 466.
- Pink Terrace of Rotomahana, 176.
- Pipeclay, origin of, in the Bagshot beds, 378.
- Plan of the Roger Mine, Dukinfield, 600.
- Plan of vein-structure in schistose rocks, 535.
- Plan and section of the White Terrace, Rotomahana, 167.
- Plans and sections of the Malvern Range, 488.
- Plas Heaton Cave, 103, 111; fossils of, 106.

- Platanites hebridicus*, 289.
 Plesiocetus, 12.
 Pliocene of India, jaw of *Hyotherium* from the, 19.
 Pliocene type of *Equus* from Nubia, molar of a, 161.
 Pluvial Period, 369.
 Porrentruy, 239, 240.
 Poços de Caldas, occurrences of foyaita at the, 457, 460.
 Podocarpus Campbelli, 289.
 — sp., 289.
 Poikilopleuron pusillus (Owen), 221.
 Point Terrible, Sark, 326; section showing hornblende-schist overlying gneiss at, 327.
 Polyzoa, Mr. E. A. Walford on some, from the Lias, 632.
 —. See also Bryozoa.
 Pontnewydd Cave, 103, 107; fossils from, 107.
 — —, stone implements from, 116.
 Porcellanite, 318.
 — from the Herefordshire Beacon, Malvern Range, 499.
 Porella concinna, 63.
 Porina grandipora, 59.
 Porphyrites, quartz-, fragments of, in the Essex Drift, 353.
 Porphyry, boulder of grey, at base of cliff, south of Saunton Down, 665.
 Port du Moulin, Sark, hornblende-schists of, 324.
 Port es Saies, Sark, 325.
 Portlandian, 264; of the Bernese Jura, 241; of the Southern Jura, 246.
 Portlemouth Ferry, mica-schist of, 730.
 Postglacial lapse of time, 404.
 Pouillerel, 242.
 Pouldu, contorted banded gneiss at the embouchure of the, 308.
 Pressure, evidence of, in the schists of the Malvern Hills, 527.
 Prestwich, Prof. J., Considerations on the Date, Duration, and Conditions of the Glacial Period with reference to the Antiquity of Man, 393.
 Psammechinus Wilsoni, 413.
 Pteroceran, 261, 263, 264: of the Bernese Jura, 239; fossils of the, 239; of the Southern Jura, 245; fossils of the, 246.
Ptychodus, Agassiz, dentition and affinities of the Selachian genus, 121.
Ptychodus decurrens, 123–130.
 — *paucisulcatus*, 127.
Ptychodus polygyrus, 127.
 Purbeckians, 265; of the Bernese Jura, 241; of the Southern Jura, 247.
 Quartz-porphyrates, fragments of, in the Essex Drift, 353.
 Quartz-rock, fragments of, in the Essex Drift, 359.
 Quartz-syenite, gneissic, from North Hill, Malvern Range, 490.
 Quartz-tourmaline, fragments of, in the Essex Drift, 353.
 Quartz-trachyte, fragment of, in the Essex Drift, 354.
 Quartzite boulders and grooves in the Roger Mine at Dukinfield, 599.
 — (itacolumite) of the Corrego do Quartel, 461; of the Rio das Antas, 471.
 — schist, micaceous, from Raggedstone Hill, Malvern Range, 505.
 Quartzites, fragments of, in the Essex Drift, 359.
Quercites granlandicus, 291.
 Quimperlé, older rocks of, 304–314.
 Radcliffe, Mr. James, on Grooves and Quartzite Boulders in the Roger Mine at Dukinfield, 599.
 Raggedstone Hill, Malvern Range, 534; felsite in, 527; rocks from, 504, 505; section through, 488.
 Rainfall, of the Glacial period, 403; influence of, on Glaciers, 404.
 Raisin, Miss Catherine A., on the Metamorphic Rocks of South Devon, 715.
 Ravenswood, brook-sections in the Bagshots, south of, 382, 383.
 Reach, Chalk-marl and Totternhoe Stone at, 552.
 Red Chalk of Hunstanton, 552, 592; chemical composition of the, 588.
 Redan Hill, Aldershot, section from Thorn Hill to, 431.
 Reid, Mr. C., on the origin of Dry Chalk valleys and of Coombe Rock, 364.
 Remains of Fishes from the Keuper of Warwick and Nottingham, 537.
Reptocavea aspera, 347.
 Rhyl, section in drift-beds near, 98.
 Rhynchonella Cuvieri, zone of, 563.
Rhynchopora longirostris, 70.
 Rhynchosauridæ, 691.
Rhynchosaurus articeps, 676, 689.
 Rhyolite, ejected from Tarawera, 184; near Quimperlé, 306.

- Rio de Janeiro, sketch-map of part of the province of, 458.
- Rio Pardo, 471.
- River-origin of the Gravels of Ardtun and Carsaig, 284.
- Roberts, Mr. T., on the Correlation of the Upper Jurassic rocks of the Swiss Jura with those of England, 229.
- Roche, 236.
- Rock, Coombe, and Dry Chalk valleys, on the origin of, 364.
- Rocks of Brittany, structures and relations of, 301.
- , igneous, on the alleged conversion of crystalline schists into, in County Galway, 517.
- of Sark, Herm, and Jethou, 322.
- of the Essex Drift, 351.
- of the Malvern Hills, 481.
- , Upper Jurassic, of the Swiss Jura, correlation of, with those of England, 229.
- Roger Mine at Dukinfield, grooves and quartzite boulders in the, 599.
- Roscoff, older rocks of the district of, 314; gneisses of, 314; view of low cliff at, 314; granite near, 316; amphibolite of, 317.
- Rother, section across the valley of the, 640.
- Rotokanapanapa, mud-volcanoes of, 174.
- Rotomahana, explosion of, 181, 182; effects of eruption upon, 183.
- , Lake, 179; disappearance of, 177.
- , Terraces of, 165.
- Rotomakiriri, Lake, disappearance of, 177.
- Rotorua, hot springs of, 181.
- Rowe, Rev. A. W., on the Rocks of the Essex Drift, 351.
- Roydon, Totternhoe Stone near, 558.
- Ruapehu, 178, 181, 182.
- Rutley, Mr. F., on the Rocks of the Malvern Hills, 481.
- St. Anne's Hill, section from St. George's Hill to, 453.
- St.-Asaph Drift of the Vale of Clwyd, 79.
- , fossils of the Drifts of, 89, 93-97.
- , section in the east bank of the Elwy below the Mount, 81.
- St. George, section in quarry near the village of, 85.
- St. George's Hill, section from, to St. Anne's Hill, 453.
- St. Imier, 242, 247, 248.
- St. Ursanne, 238.
- Ste. Croix, 243, 244, 248.
- Salcombe, section of cliff opposite Old Castle near, 729.
- estuary, boundary of slaty and metamorphic series near, 717; interbanded series of, 727; chlorite-schist of, 728; section across eastern arm of, 732.
- Salenia tertiaria, 412.
- Sandringham, Gault at, 552; Totternhoe Stone near, 559.
- Sandstones, fragments of, in the Essex Drifts, 360.
- and conglomerates of the Corregodo Quartel, 462.
- Sao Paulo, sketch-map of part of the province of, 458; Upper Palæozoic deposits in, 461.
- Sark, map of, 323; rocks of, 322; hornblende-schist of, 324; Creux-Harbour gneiss of, 326; granitic rock of, 328, 333, 334; veins and dykes in, 332.
- Sarsens, distribution of the, 380.
- Saunton Down, cliff of consolidated sand at, 661; boulder of grey porphyry at base of cliff south of, 665; boulder of red granite in ancient beach, south of, 666.
- Scaldicetus, 14.
- "Schillerization," 492.
- Schist, mica-, formed from felsite, in Raggedstone Hill, 530.
- , Piedmontite-, occurrence of, in Japan, 474.
- Schists, crystalline, fragments of, in the Essex Drifts, 359, alleged conversion of, into igneous rocks, in County Galway, 517; of the Malvern Hills, 525.
- , injection-, in the Malvern Hills, 532.
- of the Ile de Groix, 302.
- of the Malvern Hills, diorites in the, 526; granite in the, 526; felsite in the, 527.
- , simple, of the Malvern Hills, 528.
- Schistose rocks, plan of vein-structure in, 535.
- Schistosity, period of, in the rocks of the Malverns, 535.
- Schizoporella cinctipora*, var. *personata*, 67.
- *circinata*, 64.
- *clavula*, 65.
- *conservata*, 65.
- *cribrilifera*, 65.
- *hyalina*, 68.
- *obliqua*, 66.

- Schizoporella Ridleyi*, 64.
 — *tuberosa*, var. *angustata*, 67.
 Scoble Point, 728.
 Scotland, Lower Carboniferous strata of, species of the genus *Diphyphylum*, Lonsdale, in the, 33.
 Sections, diagram- at bend of River Elwy, near Dol, 75; in the sea-cliff N.W. of the Bath House, Abersrhyd, Colwyn Bay, 76; in the east bank of the Elwy, below the Mount, St. Asaph, 81; in quarry near the village of St. George, 85; of the White Terrace, Rotomohana, 167; of contorted strata overlain by current-bedded deposits, at Coogee Bay, near Sydney, N.S.W., 194; in a quarry near the roadside, south-east of Liesberg, 234; in railway-cutting north of Moutier station, 241; of west side of ravine, Ardtun Head, 275; in quarry on east side of ravine, Ardtun Head, 275; in second ravine, Ardtun Head, 278; in face of cliff, Ardtun Head, 279; of leaf-bed and gravels at Ardtun, 280; of lower part of cliff at Malcolm's Point, near Carsaig, 282; diagrammatic, of contorted banded gneiss at the embouchure of the Pouldu, 308; of banded gneiss and amphibolite at the embouchure of the Pouldu, 311; of micaceous gneiss with intrusions of granite, 313; of gneiss and granites at Roscoff, 316; showing "false-bedding" in hornblende schists in Sark, 324; showing hornblende-schists overlying gneiss in Sark, 327, 328; of granite overlying hornblende-schist in Sark, 330; of dry chalk coombes in the South Downs, 367; from Wellington College to Wokingham, 388; from the river Loddon to Ascot race-course, 388; from Thorn Hill to Redan Hill, Aldershot, 431; from Gravel-pit Hill, Aldershot, to Ash Green, 435; across Aldershot Town, 438; in Walton Common, 445; in Hatch-Farm Clay-pit, Woburn Hill, 448; from St. George's Hill to St. Anne's Hill, 453; of decomposed dyke in cutting, Corrego do Quartel, 463; on railway near Pinhalzinho, 464; across and on the sides of the tunnel near Pinhalzinho, 466; diagrammatic, through the Malvern Hills, from south to north, 488; through North Hill and the Worcestershire Beacon, 510; of granite in jointed diorite, near Glendalough, 519, 520; of diorite in granite, near Glendalough, 521; of a contorted granite-vein in gneiss, 527; showing passage of felsite into schist in Raggedstone Hill, 530; of chalk-marl and gault obtained by boring near Roydon, 553; in quarry at Stoke Ferry, 556; in Dersingham parish chalk-pit, 560; of cliff near the Lighthouse at Hunstanton, 562; showing the alternation of Gault and Lower Chalk between Cambridge and Hunstanton, and the thinning-out of the Gault between Cheddington and Dersingham, 595; on Fittleworth Common, 639; at Stopham Bridge, 639; across the valleys of the Rother, Arun, and Stor, 640; on Sullington Common, 641; at Coatham Firs, 642; on Longbury Hill, 643; at Inholmes Farm, 645; at Selmeston Church, 647; general, across the river-valleys of the Southern Wealden area, 656; across the Arun and Adur watershed, 656; across the Adur and Ouse watershed, 656; from Ashurst to Henfield, across the Adur Valley, 656; diagram-, showing mode of formation of some of the high-level beaches of Devonshire, 659; diagram-, showing succession of deposits west of Saunton Court, 660; diagram-, across the South Flank of Saunton Down, 661; of cliff opposite Old Castle, near Salcombe, 729; across eastern arm of Salcombe estuary, 730; of Old-Meadows pit, near Bacup, 734.
 Seeley, Prof. H. G., on a sacrum, indicating a new type of bird, *Ornithodesmus cluniculus*, Seeley, from the Wealden of Brook, 206.
 —, on *Heterosuchus valdensis*, Seeley, a Procelian Crocodile from the Hastings Sand of Hastings, 212.
 —, on *Patricosaurus merocratus*, Seeley, a lizard from the Cambridge Greensand, preserved in the Woodwardian Museum of the University of Cambridge, 216.
 —, on *Aristosuchus pusillus* (Owen), being further notes on the fossils described by Sir R. Owen as *Poikilopleuron pusillus*, Owen, 221.
 Selmeston Church, section at, 647.
Semionotus Brodiei, 539.
 — sp., 539.
 Septastræa, 24.
 Sequanian of the Bernese Jura, 237; fossils of the, 238.

- Sequoia Langsdorfi*?, 289.
 Serra do Bocaina, occurrence of foy-
 aite in the, 457.
 — do Canastra, 457.
 — do Espinhaco, 457.
 — do Mar, occurrence of foyaites
 in the, 457.
 Shell-beach at north end of Herm,
 333.
 Shells, marine, in drift on Caerhug,
 86.
 Shouldham, Chalk-marl at, 558.
 Shrewley, notes on the Upper Keuper
 section at, 540.
 Silurian conglomerates of Killary Har-
 bour, constituents of the, 523.
 Siluro-Devonian beds, ice-action in, in
 New South Wales, 195.
 Smittia biincisa, var. bicuspis, 58.
 — Napierii, 59.
 Snapes, 728.
 Snettisham, section of Lower Chalk
 near, 561.
 "Société Ouralienne d'Amateurs des
 Sciences Naturelles," notice of exhibi-
 tion by the, at Ekaterinebourg,
Proc. 86.
 Soham, Cambridge Greensand near,
 547.
 Soleure, 245.
 South Devon, Miss C. A. Raisin on
 the metamorphic rocks of, 715.
 — Downs, marine erosion of the,
 364; contour-map of the, 366; sec-
 tions in the, 367.
 — Pool, boundary of slaty and
 metamorphic rocks near, 717; mica-
 schists south of, 730.
 Soyhière, 236.
 Spencer, Mr. John, on Boulders found
 in seams of coal, 735.
Sphenodon, 676, 677, 679, 680, 681,
 687.
 Sphenodontidæ, 691.
 Sphenodontina, 691.
 Spongitan, 258.
 "Spongitiën," 242.
 Squalodontidæ, 15.
 Stanley, in the Falkland Islands, Sir
 A. Barkly on the slip of a peat-
 bog at, *Proc.* 2.
 Stanley, Mr. W. F., on the probable
 amount of former glaciation of Nor-
 way, *Proc.* 83.
 Steam-jets in the hill surrounding
 Terata, 175.
 Steganoporella neozelanica, 50.
 Stoke Ferry, Gault near, 547; boring
 at, 548; Totternhoe Stone at, 555,
 557; section in quarry at, 556.
Stomatopora elongata, 636.
 — granulata, 341.
 — major, 342.
 Stone implements from Pontnewydd
 Cave, 116.
 Stopham Bridge, section at, 639.
 Stor, section across the valley of the,
 640.
 Strain-slip cleavage, 725.
 Strata, contorted, overlain by current-
 bedded deposits, in the Hawkes-
 bury series, Australia, 194, 195.
 Stratification, absence of, among the
 crystalline rocks of the Malvern
 Hills, 534.
 Stratigraphical relations of the meta-
 morphic rocks of South Devon,
 727.
 Stratigraphy of the Upper Cretaceous
 deposits in West Suffolk and Nor-
 folk, 545.
 Strood, well-boring at, 203.
 Subaerial deposits of the Southern
 Wealden area, 649.
 Suffolk Crag, Cetacea of, 7.
 —, West, and Norfolk, Messrs. Hill
 and Jukes-Browne on the Lower
 Part of the Upper Cretaceous
 Series in, 544.
 Sullington Common, section on, 641.
 Supercyrtis digitata, 344.
 Surface-drift of the Vale of Clwyd,
 97.
 Swinyard's Hill, 534; section through,
 488; rocks from, 500-503; mica-
 gneiss formed from granite in, 528.
 Swiss Jura, correlation of Upper Ju-
 rassic Rocks of, with those of
 England, 229.
 Sydney, contorted strata overlain by
 current-bedded deposits at Coogee
 Bay near, 194.
 Syenite, fragments of, in the Essex
 Drift, 352.
 Talargoch beds, 86.
 Tarawera, Mount, 179; account of
 the eruption of, 181; products of
 the eruption of, 184; map of the
 country around, after the eruption,
 180; cause of the eruption of, 187.
 Taxus Campbelli, 289.
 Temora, New South Wales, ice-action
 in Siluro-Devonian beds at, 195.
 Terata Geyser of Rotomahana, 165,
 167, 168; steam-jets in the hill
 surrounding, 175.
 Terraces of Rotomahana, 165.
 "Terrain à chailles marno-calcaire,"
 233.

- "Terrain à chailles siliceux," 234, 248, 258, 259; fossils of, 239.
- Terrible Bay, Sark, 325, 326.
- Tertiaries, Australian, Revision of the Echinoidea from the, 411.
- of Maryland, *Glyphastræa Forbesi* from the, 24.
- Thiergarten, 233, 234, 236, 238.
- Thjórsá, Iceland, analysis of eucrite lava from, 498.
- Thomson, Mr. James, on the Occurrence of species of the genus *Diphyphyllum*, Lonsdale, in the Lower Carboniferous Strata of Scotland, with a description of some new species, and notices of varieties, 33.
- Thorn Hill, Aldershot, section from, to Redan Hill, 431.
- Tingua, occurrence of foyaites at the peak of, 457, 459.
- Titanosaurus, 157, 159.
- Tongariro, 179, 181, 182.
- Totternhoe Stone in West Suffolk and Norfolk, 596; fossils of the, 577; minute structure of the, 584.
- — and Chalk-marl in West Suffolk and Norfolk, 552.
- Trachytes, superficial fragments of, in Essex, 355.
- , quartz-, fragment of, in the Essex Drift, 354.
- Tramelan, 241.
- Traps of Ardtun Head, 272.
- Tremeirchion, caves near, 104, 108.
- Trias in Warwickshire, notes on, 540.
- Triassic Beds at Colwick Wood, near Nottingham, 542.
- deposits, supposed, in Sao Paulo and Parana, 461.
- Tubulipora biduplicata*, 343.
- *Campicheana*, 343.
- *inconstans*, 633.
- sp., 635.
- Turritella? sulcifera*, 630.
- Twinning of Japanese crystals of Piedmontite, 475.
- Ulrich, Prof., notice of discovery of a peculiar alloy of Nickel and Iron in New Zealand rocks, *Proc.* 30.
- Valangin, 247, 248.
- Valleys, dry Chalk-, and Coombe Rock, Mr. Clement Reid on the origin of, 364.
- Vallorbes, 248.
- Vein-structure, plan of, in schistose rocks, 535.
- Veins, mineral, in Sark, 332.
- Q. J. G. S. No. 172.
- Vermes, 239.
- Villars, 239.
- Villers-le-Lac, 247.
- Virgolian, 261, 263, 264; of the Southern Jura, 246; of the Bernese Jura, 240.
- Vorbourg, 235, 237, 239.
- Wahanga, eruption of, 181.
- Wairakei, hot springs of, 183.
- Walford, Mr. E. A., on some Polyzoa from the Lias, 632.
- Walton-Common Section, Mr. W. Hudleston on the, 443; continuation of the, 445, 446.
- Warfield Brick-yard, section in, 386.
- Warwick and Nottingham, remains of Fishes from the Keuper of, 537.
- Warwickshire, notes on Trias in, 540.
- Waters, Mr. A. W., on Tertiary Chilostomatous Bryozoa from New Zealand, 40.
- , on Tertiary Cyclostomatous Bryozoa from New Zealand, 337.
- Wealden Area, Mr. J. V. Elsdon on the Superficial Geology of the Southern part of the, 637.
- of Brook, sacrum from, indicating a new type of bird (*Ornithodesmus cluniculus*, Seeley), 206.
- Wellington College, section of Bagshot beds to the north of, 384; section from, to Wokingham, 388.
- Well-section at D lines, South Camp, Aldershot, 434.
- Wereham, Chalk-marl near, 557.
- West Dereham, Gault near, 547, 548, 549.
- West Row, Totternhoe Stone at, 554.
- Whitaker, Mr. W., further notes on the results of some deep Borings in Kent, 197.
- White Island, New Zealand, 179, 183.
- Terrace of Rotomahana, 165.
- Whittington, Melbourn Rock at, 566; section at, 566.
- Wilson, Mr. E., notes on the Triassic beds at Colwick Wood, near Nottingham, 542.
- Winds Point, section through, 488; felsite in the, 527.
- Woburn Hill, section in Hatch-Farm Clay-pit, 447, 448.
- Woburn Hill, section through, 453.
- Wokingham-Sandhurst Road, well-section near the, 382.

- Wokingham, section through, 388.
Wollaston Donation Fund, award of the, to Mr. B. N. Peach, *Proc.* 31.
— Gold Medal, award of the, to Mr. J. W. Hulke, *Proc.* 30.
Wollongong beds, 190, 191.
Wood, silicified, fragments of, in the Essex Drifts, 360.
Woodward, Mr. A. S., on the Dentition and Affinities of the Selachian genus *Ptychodus*, Agassiz, 121.
Worcestershire Beacon, Malvern Range, rocks from the 494-496; section through the, 488; and North Hill, section through, 510.
Wych Pass, 534; section through the, 488; fault near the, 484; rock from the, 505.

END OF VOL. XLIII.

